

Birla Central Library

PILANI (Jaipur State)

Class No :- 741.67

Book No :- 54245

Accession No :- a

INDUSTRIAL ART
EXPLAINED

BOOKS BY THE SAME AUTHOR

Design, Architecture, Furniture and Interior Decoration:

THE MISSING TECHNICIAN IN INDUSTRIAL PRODUCTION

ARTIFEX, OR THE FUTURE OF CRAFTSMANSHIP

PLASTICS AND INDUSTRIAL DESIGN

(With a Section on the different types of Plastics, their properties and uses, by Grace Lovat Fraser)

MEN AND BUILDINGS

THE ENGLISHMAN'S CASTLE

HOUSE OUT OF FACTORY

(in collaboration with Grey Wornum, F.R.I.B.A.)

THE HOUSE WE OUGHT TO LIVE IN

(in collaboration with Leslie Mansfield)

TIME, TASTE AND FURNITURE

ENGLISH FURNITURE

(The Library of English Art)

MODERN HOME FURNISHING

SIMPLE FURNISHING AND ARRANGEMENT

SIMPLE SCHEMES FOR DECORATION

COLOUR AND COMFORT

BRITISH FURNITURE MAKERS

(Britain in Pictures Series)

Social History, etc.:

THE AMERICAN NATION: A SHORT HISTORY OF THE UNITED STATES

HOME LIFE IN HISTORY

(in collaboration with C. Thompson Walker)

WORD WARFARE: SOME ASPECTS OF GERMAN PROPAGANDA AND
ENGLISH LIBERTY

WHAT ABOUT BUSINESS? *(A Penguin Special)*

Mr. Gloag has also edited the following books:

DESIGN IN MODERN LIFE

(with contributions by Robert Atkinson, Elizabeth Denby, Maxwell Fry, A. B. Read, Gordon Russell, James Laver and Frank Pick)

DESIGN IN EVERYDAY LIFE AND THINGS

(with contributions by W. H. Ansell, C. H. Collins Baker, B. J. Fletcher, Frank Pick, Gilbert Russell and H. P. Shapland)

THE PLACE OF GLASS IN BUILDING

(with contributions by Lionel Budden and G. A. Jellicoe)

INDUSTRIAL ART EXPLAINED

by

JOHN GLOAG

London

GEORGE ALLEN AND UNWIN LIMITED

FIRST PUBLISHED IN 1934
SECOND IMPRESSION, 1945
REVISED AND ENLARGED EDITION, 1946

ALL RIGHTS RESERVED
PRINTED IN GREAT BRITAIN
Printed in 11-Point Baskerville
BY UNWIN BROTHERS LIMITED
WOKING

FOREWORD TO THE REVISED EDITION

WHEN this book was first published in 1934 it consisted of eight chapters, an introduction, which examined the case for an Academy of Design, forty-one line drawings in the text and sixteen plates of half-tone illustrations. It was written before I had visited the United States and had acquired first hand experience of the operation of industrial design in America. When I was invited to prepare a revised edition, I soon realised that the book demanded re-writing. It has been re-written, and little of the original text remains. Four fresh chapters have been added, the introduction omitted—for events have caught up with many of the proposals that were made in it—new black and white illustrations collected from contemporary sources or specially drawn for the text, and the number of plates increased to forty-eight, including some in colour. Not only the size, but the scope of the book has thus been enlarged, though its basic intention remains unaltered, which is to explain the character of industrial art so that its manifestations may be recognised and appraised and its possibilities understood and explored.

Since this revised edition has been set up in type, the prospect of harnessing atomic energy for the benefit of mankind has promised a Third Industrial Revolution during the second half of this century. It is now within our power to destroy or remake civilisation quickly and effectively. The release and beneficent use of atomic energy would give us all the power we want; and such unlimited power could, in alliance with our existing and revolutionary knowledge and control over the manufacture and production of materials, change the face of civilisation within two generations. The whole character of industrial art could thus be altered for better or worse, because the limitations, the frustrations and the disciplines, that have hitherto restrained men in the devising and production of artifacts would be largely removed.

JOHN GLOAG

November, 1945

DEDICATED TO
FRANK PICK

When this book was first issued in 1934, Frank Pick was living and working for the benefit of Londoners. He died in 1941. He was the most outstanding patron of industrial art of his time, and his work for the Traffic Combine, that preceded and set the standards for the London Passenger Transport Board, gave to the Capital a railway system and rail and road vehicles unmatched in any other city in Europe or America and which won world-wide admiration. The trains, trams, buses and trolley buses controlled by the Combine, the stations and bus shelters, the automatic ticket machines, signs and notices and printed material all bore the impress of good design, and they achieved a recognisable unity—they were all obviously conceived by designers who were inspired but never limited by enlightened patronage. Frank Pick had enormous patience and a critically eager knowledge of design; his judgment enabled him to choose able designers and to give them opportunities; and he used his knowledge and employed designers in a completely matter of fact and normal way in the ordinary course of his work as a responsible business executive. His practical approach to design in industry was disclosed when I asked him whether he would allow me to dedicate this book to him.

“Why should you?” he demanded.

I said that, apart from my personal regard for him, he had done more to improve standards of industrial art than any other living man and that was why I wanted to make the dedication.

“All right,” he said; “but I was just doing my job.”

Every Londoner knows how brilliantly and thoroughly he did that job.

ACKNOWLEDGEMENTS

For permission to quote some extracts from his Memorandum on the position of the Designer for British Industries after the war, I am indebted to Dr. Nikolaus Pevsner, and my thanks are also due to Mr. Raymond Loewy, Hon.R.D.I., and Mr. Hartland Thomas, F.R.I.B.A., for their courtesy in allowing me to reproduce in the Appendix papers they have delivered on the subject of design. I would like to record my gratitude to all the manufacturers and designers who have allowed me to reproduce illustrations of their work and whose names are acknowledged in the captions; to Messrs. Harry Jones, Michael Rachlis, Leonard Rosoman, Grey Wornum and Hilton Wright who have made special drawings for this book; to Mr. Howard Myers the editor of *The Architectural Forum* of New York and the editorial staff of that journal who helped me to collect material in the United States; to the public relations department of the General Post Office and to the Great Western Railway, the London, Midland and Scottish Railway and the London Passenger Transport Board.

I was first introduced to that critical, mid-Victorian writer of guide books, Samuel Sidney, by my friend and colleague, C. C. J. Simmonds, who owns the copy of *Railway Rides* from which several quotations are made.

J. G.

CONTENTS

	PAGE
Foreword to the Revised Edition	5
List of Illustrations in the Text	10
List of Plates	12
CHAPTER	
I. Industrial Art Explained	15
II. The Operation of Industrial Design	23
III. The Influence of Architectural Tradition on Industrial Art	38
IV. Industrial Architecture in the Nineteenth Cen- tury	65
V. Industrial Design and the Manufacturers	86
VI. Industrial Design and the Engineers	100
VII. The Revival of Handicrafts and the Artist- Craftsmen	117
VIII. Educational Propaganda for Industrial Art, 1914-1945	129
IX. The Present State of Industrial Art	141
X. The Influence of Materials on Design	166
XI. The Operation of Commercial Art	186
XII. The Designer and the Future	203
Sources of Reference in the Text	212
A Short List of Books on Industrial and Archi- tectural Design	220
APPENDIX	
I. Selling Through Design, by Raymond Loewy, Hon.R.D.I.	226
II. Materials and Design. Extracts from a paper by M. Hartland Thomas, M.A., F.R.I.B.A.	235
Index	246
Plates I to XLVIII	

ILLUSTRATIONS IN THE TEXT

	PAGE
Hottentot arrow quiver and a modern golf club bag	22
Ejector for soil sterilisation fluid	28
Three stages in the development of a solid fuel-burning cooker and water heater	30-31
(1) a pre-1914 model	
(2) simplified version, inter-war period	
(3) contemporary design by Grey Wornum	
Projector heating unit	32
Section and plan of projector heating unit	33
Unit fireplace for space heating and hot water designed by Grey Wornum	36
Unit fireplace used as central feature with bookcase cupboards on either side	37
The Greek Doric order	40
The Greek Ionic and Corinthian orders	41
The Roman Doric and Tuscan orders	44
The Roman Ionic and Corinthian orders	45
The first iron bridge at Coalbrookdale, Shropshire	52
The Albion Mills designed by John Rennie, and the Soho Works of Boulton and Watt of Birmingham	55
Egyptian influence in early nineteenth century interior	56
The classical background in the eighteen-twenties	57
The title page from Pugin's book of <i>Contrasts</i>	59
Early nineteenth century Gothic background showing retention of classical orderliness	60
Early nineteenth century Gothic sideboard	61
Early railway architecture: Chesterford station, and the Congleton viaduct	69
Bridges at Hampton Court and Hammersmith	70
Station signal with cottage	72
Junction signals and signalman's cabin	73
Rugby Road bridge	74
Woburn station	74
Shugborough Park tunnel entrance	75
The Forth Bridge from a drawing by Hilton Wright	78
The Tower Bridge from a drawing by Hilton Wright	79
The approach to Ludgate Hill by Gustav Doré	81

INDUSTRIAL ART EXPLAINED

	PAGE
Lamp standards at Trafalgar Square, Cannon Street station and St. Pancras station	84
Example of "workman's art" according to John T. Emmett	84
The conventionalised acanthus leaf ornament	88
Conventional ornamental forms in wrought iron work	90
Mid-eighteenth century elbow chair	92
Early Victorian chair back	93
Early Victorian table legs	97
Early nineteenth century stage coach	102
Design for a steam coach by Burstall and Hill	103
Caricature of steam coach by Robert Cruikshank	103
Page from <i>The Mirror</i> , February 15th, 1823, showing patent steam carriage by Julius Griffith	104
Passenger railway coach on Stockton and Darlington Railway	105
The Killingworth locomotive designed by George Stephenson	107
The "Rocket" locomotive designed by George and Robert Stephenson	107
The "Lion" hauling a train of first-class and third-class carriages	110
The first British corridor train built by the Great Western Railway	111
London and North Western passenger locomotive, early eighteen-fifties	113
American river steamboat showing open platforms and interior of the saloon from a drawing by Leonard Rosoman	114
Early American Pullman car exterior and interior views from a drawing by Leonard Rosoman	115
The "Aga" heat storage cooker	150
Ekco radio set designed by Wells Coates	153
Two interiors designed by Michael Rachlis	160-161
Walton bridge in the eighteenth century	168
A Sussex farm waggon	169
Solid fuel boiler, pre-1939 model, in cast iron	172
Solid fuel boiler in enamelled cast iron designed by Grey Wornum	172
Modern metalwork on a staircase	174
Portable electric fire in aluminium designed by Christian Barman	176
Refrigerator van with aluminium body	179
Lamp and table designed by Michael Rachlis	182
Two chairs with aluminium frames, designed by Michael Rachlis	182

LIST OF PLATES

(The Plates begin after page 248)

PLATE

1. Two chairs in plywood and rubber designed by Michael Rachlis, showing colour of upholstery
2. Chair designed by Milner Gray for Messrs. Christie-Tyler
Sun lounge divan designed for Pel Limited, by Wells Coates
3. Typewriting desk and chair designed by Wells Coates
4. Television set designed by Misha Black for E. K. Cole Limited
5. Two radio table sets designed by R. D. Russell for Murphy Radio Limited
6. Clocks designed by Henry Dreyfuss for the Westclox Division of General Time Instruments Corporation, U.S.A.
7. The Schick electric razor before and after re-design by Raymond Loewy
8. Electric light fittings designed by A. B. Read for Troughton & Young Limited
9. Decanter and glasses designed by Keith Murray for Stevens & Williams Limited
10. Three aluminium kettles and a coffee percolator, by the Design Research Department of Aluminium Laboratories Limited, Montreal
11. Five-pint and double saucepan in aluminium, by the Design Research Department of Aluminium Laboratories Limited of Montreal
12. Aluminium roaster with insulated plastic grips by the Design Research Department of Aluminium Laboratories Limited of Montreal
13. Cooking utensils of vitreous enamelled cast iron made by Radiation Limited
14. Late Victorian and modern cast iron pillar boxes
15. Examples of progress in design of telephone kiosks
- 16 and 17. Progress in the design of G.P.O. telephone instruments
18. A China clipper, an early steamship and the emergence of the funnel as a dominating feature
19. The *Bremen* and the Diesel yacht designed by Norman Bel Geddes for Axel Wenner-Gren
20. An early locomotive, the "Lion." Great Western locomotive on the old broad gauge, the "Lord of the Isles"
21. Early twentieth century locomotive of the London and North Western Railway
Turbine engine No. 6202 of the London, Midland and Scottish Railway
The latest type of passenger train locomotive, "King George V," Great Western Railway

INDUSTRIAL ART EXPLAINED

PLATE

22. Typical locomotive and rolling stock in service on United States railroads
23. Progress of a project. S1 type locomotive designed by Raymond Loewy for Pennsylvania Railroad. Stage 1
- 24, 25 and 26. Progress of a project, Stages 2, 3, 4 and 5
- 27 and 28. Progressive stages of design in London's motor buses
29. The Vickers-Armstrong Viking air liner
30. Liberator air liner in flight
31. Interior of Liberator air liner
32. Examples of the influence of materials on design: wool-winding machine in wood
33. Bow handles in tinted plastic sheath drawn over steel tube, designed by Wells Coates
- 34, 35 and 36. Demonstration of industrial and decorative uses of glass. The "Glass Age" Exhibition train
37. The first large scale use of glass for exhibition building: the Crystal Palace
38. A suggested design for re-building the Crystal Palace, by Maxwell Fry
39. A design for re-building the Crystal Palace, by Raymond McGrath
40. Materials and architectural design: suggestion for the re-design of the Liverpool Street and Broad Street station areas in London, by F. R. S. Yorke
41. Suggestion for the re-design of Princes Street, Edinburgh, by Robert Jordan
42. Suggestion for the re-design of the Bond Street shopping area, by Howard Robertson
43. Bernini's Arcade at St. Peter's, Rome. Peter Jones' shop in Sloane Square, London
44. Exhaust fans in Mersey Tunnel ventilating station
45. The Wheeler dam built by the Tennessee Valley Authority
- 46 and 47. Examples of commercial art and industrial design related to the marketing and distribution of a product
48. Exhibition showcases at the British Pavilion of the New York World Fair, designed by Misha Black

“Every article of use has a certain size and character defined for it by the very use it is destined for, and this may never be disregarded by the designer; it is, in fact, the indispensable skeleton of his design, and has nothing to do with ornament.”

Analysis of Ornament: the Characteristics of Styles, by Ralph N. Wornum. 1855.

“There is no good reason why forms stripped clean of all considerations but function and utility should be admirable beyond that point: they may be abominable from the human standpoint, but there is no need for them to be so in the Artist’s hands.”

Modern Architecture, being the Kahn Lectures for 1930, by Frank Lloyd Wright. Lecture 2. “Style in Industry.”

REFERENCES IN THE TEXT

Footnotes have been avoided throughout the twelve chapters of this book. References are indicated by figures in the text, numbered consecutively in each chapter; and the sources of these references are set out under their appropriate chapters at the end of the book, beginning on page 212.

INDUSTRIAL ART EXPLAINED

“Men now generally understand, to employ those very tools which the *Antients* lent us, to infinite more Works than formerly; they have also of late devis'd a great Multitude of all Sorts, which were before *unknown*; and besides we may very well expect, that Time will every Day bring forth *more*. For according as the *Matter* to work upon does abound, the greater Plenty of *Instruments* must by Consequence follow; such a Connexion there is between *Inventions*, and the *Means* of inventing, that they mutually increase each other.”

The History of the Royal Society of London, by Tho. Sprat, D.D., Bishop of Rochester. From the third edition, published in London, 1722.

INDUSTRIAL art may in time to come be regarded as the characteristic achievement of our civilisation. Its manifestations, so far as they survive, may disclose to posterity all the hesitations, the conventions, the cautious dependence upon prototypes and the occasional outbursts of courageous innovation, which represent the history of design in industry since the close of the eighteenth century. Our almost exclusive preoccupation with production and mechanical efficiency during the first industrial revolution and our misunderstanding of the operation of design and the function of the designer will be duly observed; while the emergence of what has been called “machine art” may be recorded as marking the rise of the second industrial revolution. Our ways of life, the machines and arts upon which that life so greatly depends, may be revealed to the future by the chipped and rusting remains of a gas cooker or a refrigerator, the streamlined body of a motor coach or the fallen skeleton of a skyscraper. From such crushed and corroded bones, the archaeologists of the thirtieth century may attempt to reconstruct our lives. Helped a little by imagination, they may endow us with virtues, the possession of which we have never even suspected; or, with less generosity to the past, they may regard us as far worse than we really are. But it should be plainly evident to their minds, if they are investigating objectively the growth and development of our commercial machine age, that in the beginning there was industry without design, and that consciousness of a missing factor in the

INDUSTRIAL ART EXPLAINED

mechanical production of goods was so long delayed that the iron, steel and steam phase of industrialism—the first industrial revolution—was practically over before design began to secure recognition as a technical operation.

If and when it is generally recognised by manufacturers, distributors and consumers that design is a *normal* operation in the production of goods, industrial art will be liberated from the tyranny of prototypes, imposed by the memory of our pre-industrial civilisation. Meanwhile, although many people are now aware of the way good design or bad design or absence of design affects everyday existence in their homes and at their work, we still live in an age of confusion, surrounded by inappropriate survivals, beset by archaic beliefs. Art and the artist have become separated from life and particularly from industrial life. It is a startling and regrettable truth, that if every man and woman who practised the graphic or the plastic arts, or whose creative gifts found expression in that large field of activity covered by the word design, had died, say on January 1st, 1939, there would have been no appreciable difference in the conduct or character of contemporary British industry. The disappearance of the artist and the industrial designer would have been noticed in the distributing trades, but the course of industrial production would not have been affected, nor would most of the directors of industry have been dismayed by the disaster, even if they had noticed it. This unconscious indifference of organised industry to the existence of artists and designers has, with a few exceptions, been a characteristic of the commercial machine age; nor is it confined to industry. It is shared by the general public.

Why has British industry and the British public hitherto been afflicted by this indifference to industrial art? Partly because its existence and operation are unidentified, partly because we are still in a period of transition from a tranquil and orderly civilisation to one whose outlines are as yet only vaguely perceived. Not unnaturally we cherish the familiar survivals from a known and pleasant past, and we attempt to retain forms and ideas that were appropriate enough in the sixteenth, seventeenth or eighteenth centuries but which are now only limitations.

It was with the object of explaining the operation of industrial art, and illustrating its growth and possibilities that this book was first written in 1934. Since then the second industrial revolution has been swiftly developing, and the second world war has accelerated its growth. From the iron, steel and steam age we have passed into a new age of materials and power, when an abundance of light

alloys and chemically produced synthetic materials gives manufacturers and industrial designers fresh opportunities for invention and experiment, and cables carry electricity from generating stations to all parts of the country, so the location of industry is no longer determined chiefly by the proximity of fuel. This second industrial revolution could confer enormous benefits upon the domestic, commercial and industrial life of Britain: it could repair the ravages of the first industrial revolution: it could restore our national leadership in industrial technique, for it could release the great imaginative powers of our artists and designers and make their work contemporary and productive.

The significance of industrial design has been recognised by the State, for in December, 1944, the Board of Trade appointed a Council of Industrial Design, to encourage the formation of design research centres and to improve and extend education in this subject. But unless the nature and range of industrial art are understood by everybody, the patronage essential for its healthy expansion will not be forthcoming from industry, nor will it be encouraged by the distributing trades or appreciated by the consumer. What *is* industrial art, anyway? The answering of that question is the special concern of this first chapter.

The term *Industrial Art* is used throughout this book to describe the visible results of our industrial civilisation which have been or could be affected by the operation of design. It is a comprehensive term; but it covers a subject which may be conveniently divided for study, such divisions being determined by the character of industry, its services and its needs. Three main divisions are thus suggested:

1. Industrial design.
2. Commercial art.
3. Industrial architecture.

1. *Industrial design* is concerned with the products of industry, not only with consumable goods made in a factory, but with such things as vehicles, ships, lamp standards and automatic ticket machines. It may be sub-divided thus:

- (a) Design which affects the function, shape and finish of a manufactured object, for example a safety razor, a radio set, a gas cooker, a kettle or an electric iron.
- (b) Machine design, which affects the form and finish of an object with a mobile or static mechanical function, such as a locomotive, a lawn mower, a sewing machine or a typewriter.
- (c) Industrial decorative art, which creates decorative patterns

and determines the choice of colours and textures for such things as textiles of all kinds, from furnishing fabrics to shirt materials, pottery, domestic glass and wall paper.

2. *Commercial art* is concerned primarily with the distribution of goods. Its most familiar manifestations are advertising in the press; posters, window bills and signs; commercial literature, such as booklets, leaflets and folders; also display material for shop windows and showrooms; exhibition stands and the design of packaging. In this last activity it approaches *industrial design*, for with some goods the design of the package is an integral part of the manufactured object and, after sale, the pack or some part of it is kept and used by the consumers—for example, lipstick containers. Again, the choice of colour, texture and pattern for a package whatever the material—it may be aluminium foil, paper, cardboard or a transparent or opaque plastic—has presented a problem of design akin to *industrial decorative art*: with the package, a pattern has been created for the purely commercial purpose of attracting the potential purchaser; but patterns created for table ware or window curtains should have more than a transient attraction.

3. *Industrial architecture* has arisen from the need to accommodate industrial activities. It includes mills, foundries, factories—all the buildings that protect industrial workers and plant; also railway architecture, bridges, stations and signal cabins; docks, canal and river locks, dams and the buildings and appliances connected with the production and distribution of power. The form of certain large scale appliances creates a sub-division, which may be called *machine architecture*. Under this would be included gas holders, cooling towers, grain elevators, and such things as the great turbine cases on the Wheeler dam—one of the twelve dams on the controlled Tennessee River system, made by the Tennessee Valley Authority—the turbines in the vast power station at Dnieprostroy, U.S.S.R., and the exhaust fans in the ventilating stations of the Mersey Tunnel.

These three divisions, *Industrial Design*, *Commercial Art* and *Industrial Architecture*, can clarify and regulate thought about industrial art without making it inflexible, for they are not arbitrary, and they allow the whole subject to be examined without confusion. It is a subject of profound importance to a nation whose foreign trade depends largely upon the character of the goods produced in its factories; a nation, moreover, whose citizens have, as a result of two devastating wars, become alertly aware of the immense reserves of mechanical inventiveness and industrial efficiency that are mobilised

for the making of weapons when their country is threatened with extinction. From this many conclude that life in peace time could be enriched and made easier and more agreeable if such inventiveness and industrial power were allowed to satisfy the market represented by the people as a whole. For the first time in the history of civilisation we could rely on slavery without injustice, for industrialism has provided us with the most efficient and hard-working slaves in the form of machines, which save our muscles, and could shorten our working hours and lighten and minimise the everyday tasks of all men and women.

Industrial art, which is characteristic of our commercial machine age, should, like architecture, be universally enjoyed. The past provides some cautionary examples of civilisations that have collapsed, because the benefits of invention in architecture, design and the production of commodities, were withheld from large sections of the population. Perhaps the most remarkable instance of swift and complete collapse is afforded by the Cambodian civilisation, which lasted for five centuries and disintegrated in a few weeks, following a slave rebellion. A Chinese traveller named Tcheou Ta-Kouan lived at Angkor Thom, the Cambodian capital, from 1296 to 1297, and minutely described the country, the people and their customs and commerce. His writings were discovered in the Imperial Archives at Peking and were translated into French and published in 1902 by M. Pelliot.¹

Some authorities believe that this civilisation was the culmination of the great colonising movement from India which swept across the Far East over a thousand years ago. The Chinese record, set down some eighty years before the Cambodian Empire disappeared, is extensively quoted in two authoritative books on the subject: *Towards Angkor*, by H. G. Quaritch Wales, the Field Director of the Greater India Research Committee,² and *Escape With Me!* by Sir Osbert Sitwell. The magnificence of this lascivious and exotic civilisation is disclosed. Sustained by the export of luxury goods, the Cambodians reared upon a structure of slavery a state that allowed the privileged classes to devote their entire time to their two principal forms of pleasure—of which bathing was one. The slaves were drawn from primitive tribes, who were kept in a state of the utmost degradation. Only the aristocracy was allowed to have tiled roofs, the people had to be content with wooden houses roofed with thatch. No furniture or fittings were permitted in their homes. Earthenware cooking pots, coconuts used as ladles, stoves made of earth, spoons made of leaves, pewter cups or earthen bowls—such

were the miserable possessions allowed to the lower orders, in a civilisation of the most luxurious abundance. Voluptuous, aimless and wholly unstable, this Cambodian Empire nevertheless produced a masterpiece of architecture like the Angkor Vat, and buildings and sculpture which still resist the jungle and astonish the traveller by their scale, their urbane beauty, and the effortless grace of their decoration. Angkor Vat with its five conical towers, its magnificent composition, and the harmonious partnership between architect and sculptor which it represents, is unquestionably one of the great buildings of the world.

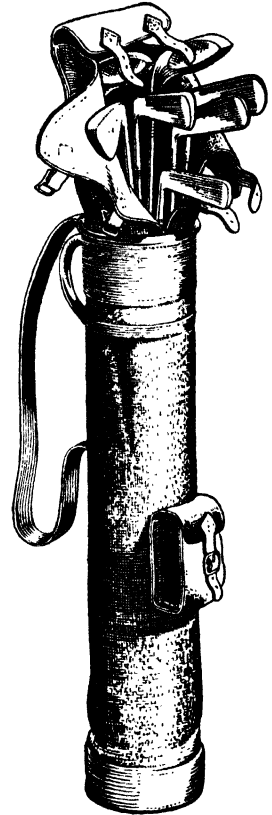
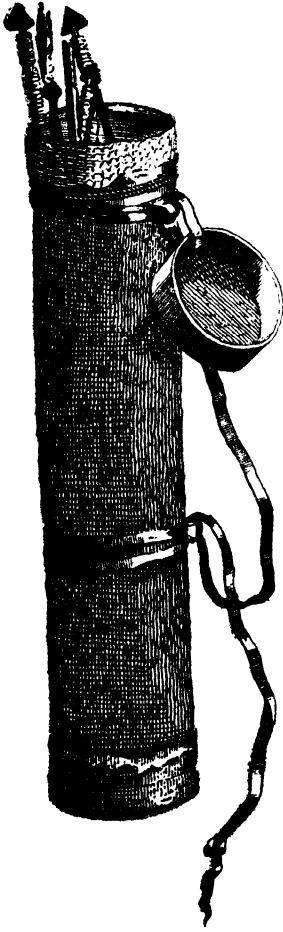
The revenue which supported this top-heavy society was derived from the export of kingfishers' wings. As Sir Osbert Sitwell explains, the Cambodian kingfishers were demanded by the Chinese market, because of their superior sheen and colouring. They were exported to Canton, where they were made into the blue and green tiaras worn by Chinese brides. This civilisation, dedicated to luxury, was overcome when the slaves rebelled during a war, and brought down the whole edifice of the Cambodian Empire. It never rose again, and, in time, passed out of memory.

Any civilisation that depends wholly or largely for its prosperity upon the export of luxury goods runs the risk of becoming so separated from reality that it is unable to meet emergencies, such as war or changing market conditions. Any civilisation that confines the consumption of goods to a privileged class is inviting social revolution of the kind that overtook and destroyed the Cambodian Empire. Any civilisation in the commercial machine age that excludes trained imagination from the production of goods is denying to consumers at home and abroad the enjoyment of industrial art, and all that it implies, and its industrialists and traders are acting as obtusely as the Cambodian grandees of the thirteenth and fourteenth centuries, the French aristocracy in the days of Louis XV and Louis XVI, or the Russian ruling classes under the Tzarist régime. This exclusion of imagination from industrial production is not an act of conscious oppression: it is an act of unconscious ignorance. Until the third decade of this century, the scope of industrial art was recognised only by a few exceptional people, and very few manufacturers or distributors had any understanding of its importance to their business. Now it is accepted by a limited number of progressive manufacturers that the shape, colour, texture and general appearance and function of goods are influenced at some stage of their production by the presence or absence of trained imagination. Industrial production commands the services of highly

qualified technicians: engineers, research chemists, metallurgical specialists, experts in management, and skilled or unskilled operatives. Working with this team are sales, marketing and publicity managers and their staffs; and all the diverse activities of these technicians and workpeople are planned by directors in charge of development, whose overriding concern is the maintenance and future of their firm's prosperity. All these people, in their own specialised departments, should be alert and receptive; and during the first industrial revolution the spectacular progress of British industry was largely attributable to the inventive powers of technicians and the enterprise and courage of manufacturers. A century of industrial opportunity, when everybody wanted British goods, accentuated the importance of production. Marketing was hardly understood: the manufacturer shipped goods overseas where people were clamouring for them, and orders poured in through the letter-box by every post, and he carried them out to suit his own convenience. Not unnaturally a "take-it-or-leave it" attitude was adopted by British industrialists, and they felt that what they made could not be bettered, either in workmanship or functional efficiency. They were never conscious that anything was missing. They were self-satisfied; but their complacency was created and nourished by economic conditions: the markets of the world urgently desired what they could make, and, as they were human beings and not coldly logical super-men, they were proud of their capacity to produce goods. Britain was called "the workshop of the world."

Industrial art was not recognised: its existence was unsuspected. A rich confusion of terms such as *applied art* and *ornamental art* prevented the emergence of any idea that from the power of machines and the nature of new materials a new form of common art might arise, under the direction of industrial designers, which would replace the old, lost common art of England. We are still far from allowing such an idea to have much practical effect on the things we make and use.

When design is free from the influence of a prototype and remains a purely functional problem of engineering, the beauty of mechanical fitness may be achieved by an apt solution. It is a beauty different in kind from that created by the artist; it is a mathematical by-product; unsought, incidental. To imagine that beauty invariably resides in a piece of competent engineering and to assume that "fitness for purpose" is the golden rule for the creation of beauty is to chain creative ideas to abject utility. Industrial art begins when the trained imagination and judgment of a designer are employed to determine the character of a manufactured article.



Left: Quiver for arrows, used by Hottentots. From Andrew Sparrman's *Voyage to the Cape of Good Hope*, 1772-1776. (Vol. I, Plate 2.)

Right: A modern golf bag. Compare this with the quiver: the functional needs are almost the same: so are the results.

THE OPERATION OF INDUSTRIAL
DESIGN

UNDER the three main divisions set forth in the last chapter we may examine not only the operation of design in modern industry, but the influence of industrial processes and materials upon the ideas of designers. In the age of handicrafts, the man who made an article very often designed it, and his design was determined by the character of the materials available, the customary methods for fabricating them, and the function of the article. As a craftsman-designer, his inventive faculties were stimulated only when he was confronted by some new problem, or when he was ornamenting his work. With primitive peoples the forms of their utensils, weapons and shelters persist for generations, until migration—enforced by change of climate or the exhaustion of hunting grounds—or the advent of foreign traders, brings them into contact with new ideas. This identity of craftsman and designer has endured for thousands of years, and the separation of the designer from the executant craftsman has occurred only when architecture has transcended its elementary function of providing shelter, or when the production of goods has been organised upon a large scale. The development of architecture established the architect as a master designer, who directed or worked with artists and master craftsmen, as Ictinus and Callicrates, the architects of the Parthenon, worked with Pheidias, the master sculptor, or as Sir Christopher Wren directed the decorative sculpture of Grinling Gibbons in St. Paul's Cathedral. The independent, *directing designer* appeared when industries began to use mass production methods, based on slave labour, though this designer's status would vary according to the industry, and it is unlikely that he would be more than a highly skilled, inventive slave himself.

Large industrial enterprises employing mass production methods flourished in the ancient world. A great deal of Greek pottery was thus manufactured and various industries served by highly organised slave labour were established throughout the Roman Empire. In the province of Britain, for example, there was a group of potteries

at Castor. Collingwood and Myres say that "here, the industry was evidently worked on a capitalist basis, with highly organised methods of manufacture and distribution. The characteristic ware of the Castor kilns is found all over Britain, and there are indications of the way in which it was shipped in barge-loads by river from the pottery wharves."¹

The civilisations of the ancient world depended on slaves to operate their industries. The saving of human toil was of no particular interest to the bureaucrats and capitalists of a slave state. Professor Gordon Childe points out that the water wheel was hardly used until the beginning of the fifth century, when the Western Roman Empire was collapsing.² No large scale development of power took place, until in the thirteenth and fourteenth centuries, an industrial district that depended largely on the use of water power grew and flourished on the Volga, above Astrakhan. It was Sarai, the metropolis of the Golden Horde, and consisted of two cities, one devoted to industry, the other to pleasure. In the former "reservoirs of water terraced at various levels unceasingly drove iron water-wheels. Here there were countless workshops; smithies, tile-works, potteries, smelting furnaces."³ Both cities were destroyed by Tamerlane. The ruins of Old Sarai, the industrial city, covered fourteen square miles. It was never rebuilt.

As manufacturing enterprise extended, the work of the craftsman in many industries was increasingly directed by a master designer and individual scope for invention was correspondingly reduced. Long before industry was gradually mechanised, during the first industrial revolution, the skill of craftsmen had been circumscribed by a pattern of organisation which imposed repetitive tasks. For example, in the workshops of such eighteenth century furniture makers as Thomas Chippendale, some men might make chair legs or seat frames and nothing else, all their working lives. Monotony is not invariably a hardship; to the uncreative mind it may be congenial, particularly when it allows the expression of personal dexterity; but executant skill in a craftsman does not imply a capacity for invention. It is true that invention occasionally springs from the exercise of skill; but rule-of-thumb methods, the memory of prototypes, and respect for custom, have been the principal influences in the lives of craftsmen for hundreds of generations. Like problems have a way of begetting like solutions, even though the results are widely separated by time and circumstance, not because of some irrepressible faculty for invention in the human mind, but because culture has been gradually diffused over the habitable globe

in the past. It is salutary to compare the Hottentot quiver for arrows with the modern golf bag. The functional needs are almost identical, so are the answers. The superiority of the twentieth century relies only upon a few superficial refinements of finish, and on the use of pierced straps and metal buckles to secure them (see page 22).

Dependence upon prototypes is deep rooted in the human mind, and even creative minds are profoundly influenced by traditions, which they accept, adapt, or reject—reactions which affect the growth and character of the arts and crafts in periods when creative minds enjoy comparative freedom. Such periods have been rare in the history of civilisation, and when they occur they leave an indelible mark. Greek intellectual life and art in the third, fourth and fifth centuries B.C., have impressed such a mark upon European culture and its great and growing branches in North and South America. But the Greek city states seldom applied the ideas of their scientific thinkers; we have inherited ideas and principles—a great structure of original thought—rich in undeveloped and astonishing possibilities, which the Greeks either ignored or despised.

Original inventions of any kind occur very rarely. There is any amount of what may be called secondary inventiveness, which arises from an alert perception of the possibilities disclosed by some principle of using power, and this practical creative faculty has flourished during the last two hundred years; but it was discouraged by the Greek attitude to life. Archimedes left no record of his mechanical contrivances, for they were the by-products of pure science and he regarded them with contempt, only condescending to exert his genius for invention to protect his native city of Syracuse when it was besieged by the Romans. The artisan was deliberately excluded from citizenship in some of the Greek states. Lowes Dickinson suggests that the reason for this was that the sort of life the artisan had to lead “was incompatible with the Greek conception of excellence.”⁴ But the artisan had no opportunity of improving his way of life, because the Greeks rejected applied science. He remained an inferior, even in the most democratic states. Yet the possibility of freeing him by the development of machinery so he could be elevated to citizenship never occurred to a society that was prolific in original invention. The gifts of science were sometimes recorded; that was all: secondary inventiveness was never encouraged in that age of mental vigour and artistic achievement. Greek science continued to produce ideas. Hero of Alexandria invented a steam engine, and in his *Pneumatica* he included such devices as siphons, fire-engines, water-

organs and the equivalent of the modern penny-in-the-slot machine. But such ideas lay fallow.

Often in the past ideas have emerged and actual inventions have been made, without anybody, even their authors, being aware of their significance. In his book, *Progress and Catastrophe*, the late Stanley Casson includes a descriptive note about the unconscious invention of movable type for printing four thousand years ago. "The art of printing," he writes, "was in fact invented by hazard about 2000 B.C., by some unknown person who fabricated that strange unique object known as the 'Phaestos Disk.' This disk is made of clay some seven and a half inches in diameter and one inch in thickness. On its two faces are inscriptions, in each case in one continuous line, arranged as a spiral so as to fit into the disk. The inscription is made by means of impressing certain signs on to the wet clay of the disk. Each sign is impressed by a matrix, probably of ivory or stone, which bore in intaglio the required design. In all there were forty-five of these movable types employed to make the inscription. Words are separated by vertical incised lines. No other instance of the signs so used has been found and the text of the double inscription cannot even be transliterated. It is thought that it is a dedication by some alien person in a Cretan sanctuary. The origin of the dedicator, from certain hints given by the character of the signs, may be Asiatic. The fabricator of the disk certainly invented the art of printing and possessed a fount of type. But he does not seem to have realised the possibilities of his invention. Nor did anyone else."⁵

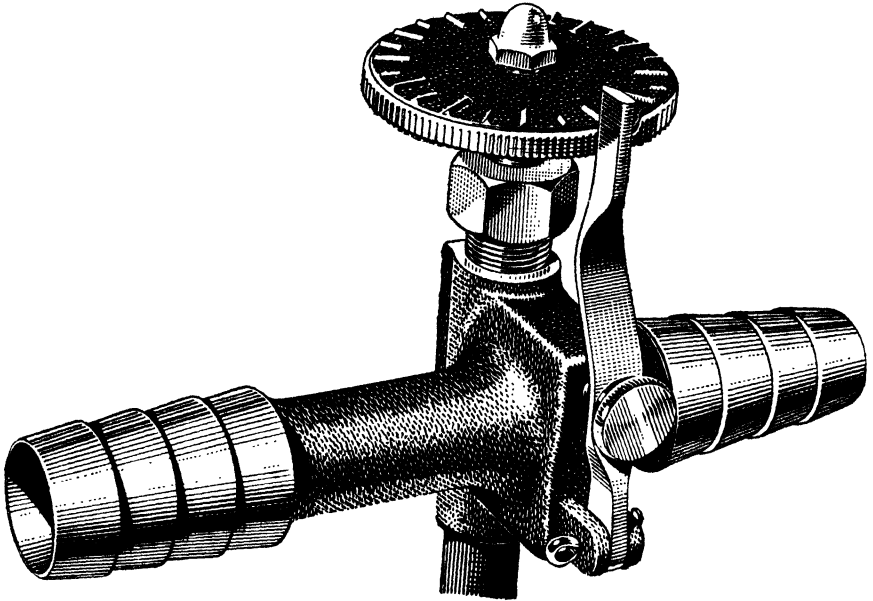
What prospects were there for such labour-saving ideas to be encouraged or adopted in the ancient world, with its established tradition of slavery and its vested interests in slave holding and trading? The age of Greek thought, the first age of reason, remained slave-bound; Rome became a utilitarian and commercial slave-state; thereafter reason and freedom were in eclipse until Greek learning and habits of thought were revived, and the Renaissance dispelled the darkness of the age of faith. In England, by the end of the seventeenth century, scientific speculation was gaining strength in an atmosphere of freedom. The Royal Society had been founded. Trade was respected, and after the Scottish Union, Britain was the largest free trade area in Europe. Science was applied to industry, and innumerable secondary inventions appeared. During the eighteenth century "a small handful of remarkable Scots and Englishmen, fewer than would be required for a football match, succeeded by their ingenuity in transforming the economic life of the country."⁶

THE OPERATION OF INDUSTRIAL DESIGN

The age of handicrafts was over: machinery, neglected and despised for centuries, rapidly invaded every form of industrial activity, replacing the traditional arts and crafts, and after the introduction of steam power enormously multiplying the output of goods. Within a century the craftsman had almost become a picturesque survival. "With iron and machinery was born a new class—the modern mechanic."⁷

The activities of mechanics and the nature of the new machine-made goods were controlled by engineers and factory owners, and in the early days of the industrial revolution they were often the same people. Skill in design disappeared, and the directors of the new industrial power were so preoccupied with the new forms of skill which arose when production was mechanised, that they never realised that anything or anybody was missing from the organisations they were establishing. The craftsman and his skill were on the way out; nothing replaced them. The mechanical methods for producing goods, the machines themselves, and the materials they consumed and fabricated, absorbed the whole attention of the engineer-industrialists of the late eighteenth and early nineteenth centuries. If handicraftsmen had thought of nothing but the excellence and efficiency of their tools and materials, the form and character of the things they made would have been fortuitous, and they would have repeated generation after generation without variation, save that derived from error, the shapes their forefathers had used. That is what the industrialists did, when they were producing goods formerly made by hand; but machinery enabled them to produce thousands of articles exactly alike; incidental variations of form were abolished.

Design was regarded as a major or minor operation of mechanical engineering; a perfectly valid though limited interpretation, which excluded the vital attribute of creative imagination. The designer was always an engineer or a superior mechanic. The work of such a technician was, and still is, clearly definable. For instance, when an appliance or a component part of an appliance is designed to perform a specific function, the most serviceable material is used, and the amount, thickness and treatment of that material are determined by the designer's estimate of the character and volume of the wear and tear to which the appliance may be subjected, and his capacity to imagine and devise the best method for securing its efficiency and convenience in use. Thus, shape and finish are settled by practical needs; but in order thoroughly to understand and select the best methods of fulfilling those needs, the designer has to use



The Ster-Izal ejector for soil sterilisation. (This drawing, made from a photograph, is reproduced by permission of Newton, Chambers and Company Ltd.)

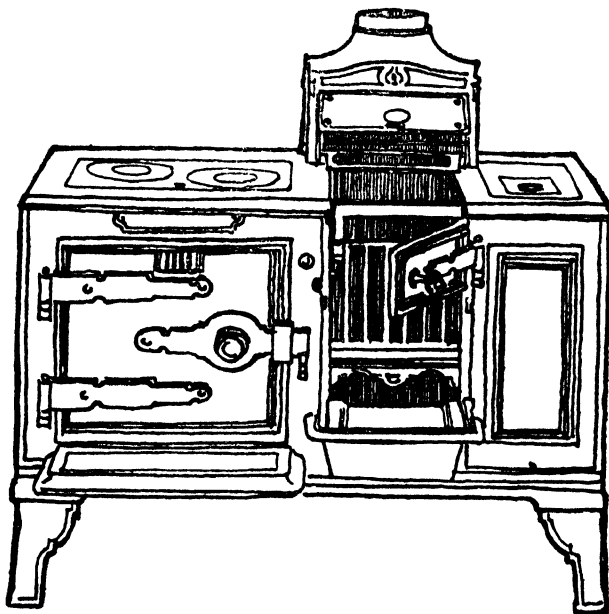
imagination, albeit his imaginative effort is informed by accurate measurement of the task ahead. He knows what performance the appliance has to give; but he is only able to estimate how well or ill it may be used; which prompts him to make it fool-proof. The result is a simple straightforward piece of machine-design, such as the ejector used for a soil-sterilisation fluid shown on this page. The selection of the material and the form of the appliance are controlled by its functional needs. Phosphor bronze is used, which resists corrosion and gives the necessary weight. One end of the ejector is connected to a water pipe, the other to the delivery point, and the dial is set to the required solution, so that when the water is turned on a consistent dilution of a known strength is automatically delivered. A mechanical problem has been adroitly solved without any unnecessary frills or trimmings.

But mechanical problems are not always solved with such exemplary tidiness, particularly when a large number of parts is necessary and a variety of functions has to be performed by an appliance. If the operation of industrial design is neglected, the final result may be complex and clumsy. At what point then in the production of an article does the industrial designer become active? *Industrial*

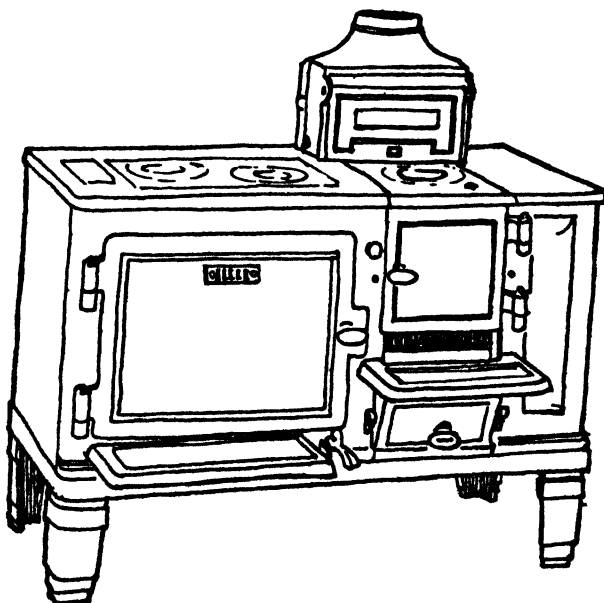
design is a basic operation, and the three sub-divisions of it, set forth in Chapter I, clearly indicate that those who practise it must be consulted when production is first planned. The industrial designer is a technician whose work should begin at the same time as the work of other technicians—the production engineers, the specialists in materials and the experts who have studied the potential market. He is not a “styler,” to be called in when materials have been selected and the technical problems of production settled. At that late stage he could only tinker with the external appearance of an article, thus repeating the errors of “applied art” which disfigured such a high proportion of manufactured goods during the nineteenth century. He is not a “putter-on” of sleek disguises for ill-planned or outmoded articles. Industrial design today, when it is concerned with articles that have a mechanical or semi-mechanical function, tends to create smooth, continuous surfaces; very different from the emphatically visible joining up of bits and pieces, and the air of heaviness and indeed excessive solidity to which a prodigal use of material gives rise. But the designer does not achieve this external smoothness by providing a cunning mask; he aims at the functional perfection which gives convenience and pleasantness in use, at economy of material and reduction of parts, thus securing savings in production and assembly.

Industrial design in operation is illustrated on pages 30 and 31 by three phases in the development of a solid fuel burning cooker and water heater. The first shows a pre-1914 model, with a black-lead finish. The second is a simplified version with an enamel finish, produced in the period between the wars. The third is designed by Grey Wornum, F.R.I.B.A. The improvement in the contemporary design comes from a thorough revision of the appliance: its trim and orderly appearance does not depend alone upon the reduction of surface variation, which allows the enamel finish to give an almost continuous smoothness of effect and greatly simplifies the job of cleaning, it reflects higher standards of efficiency in production and performance. It has been designed to comprise fewer parts. The oven door and the fire doors are insulated and their shutting edges are ground and close fitting. The designer wanted greater efficiency: he was not conducting a superficial exercise in “styling” or “streamlining”: he wanted improved doors—their neatness was incidental, though he knew how to make good use of such neatness for the general benefit of the whole design. The handle is of coloured plastic material, and the fire door drops down to provide space heating if needed and a teapot roost. The cooker is insulated on the

Three stages in the design of a solid fuel-burning cooker and water heater (These illustrations are reproduced by courtesy of the Carron Iron Company of Falkirk.)



(1) A pre-1914 model in cast iron with a black lead finish.

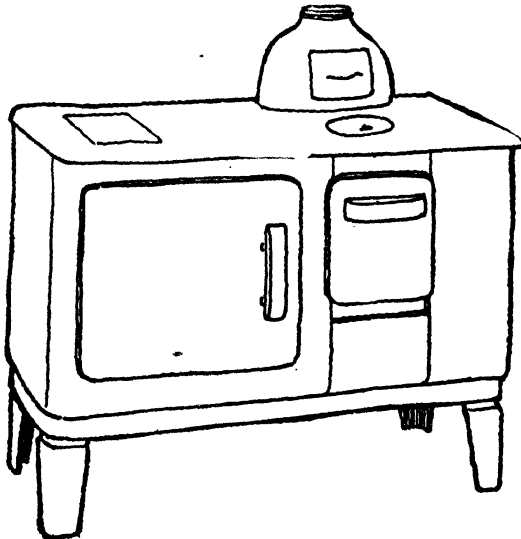


(2) A simplified version produced in the period between the wars.
This has an enamel finish.

THE OPERATION OF INDUSTRIAL DESIGN

bottom, sides and back; it has a combined mechanical device so that when the air regulator is altered, the flue damper is altered simultaneously. The fire will remain in all night, which was not possible with either of its predecessors, and is efficient enough to provide hot water and also carries one small radiator. Cast iron is used for the front, sides and hob; sheet steel for the back and linings. It is very reasonable in cost.

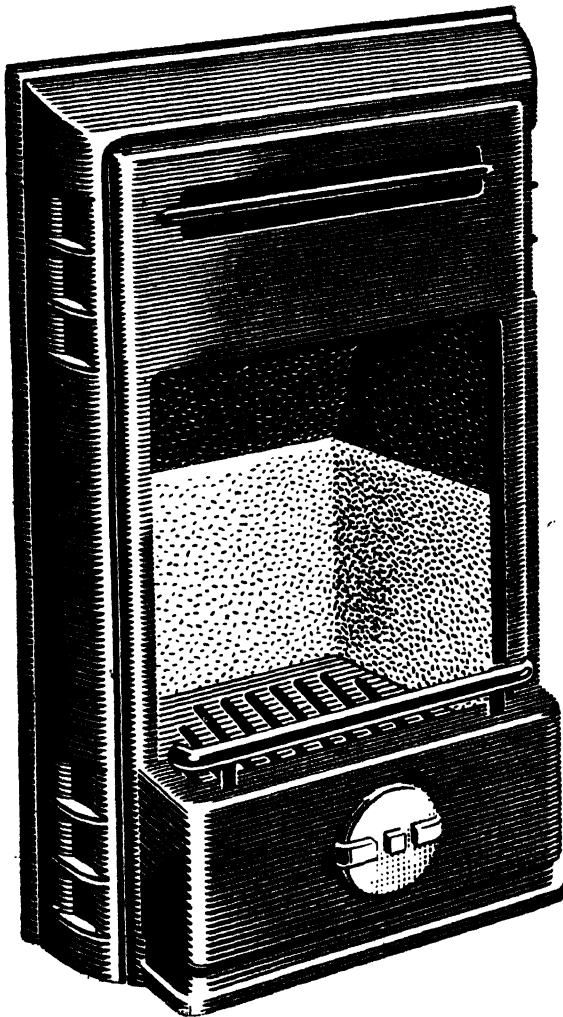
These improvements could not have taken their present form



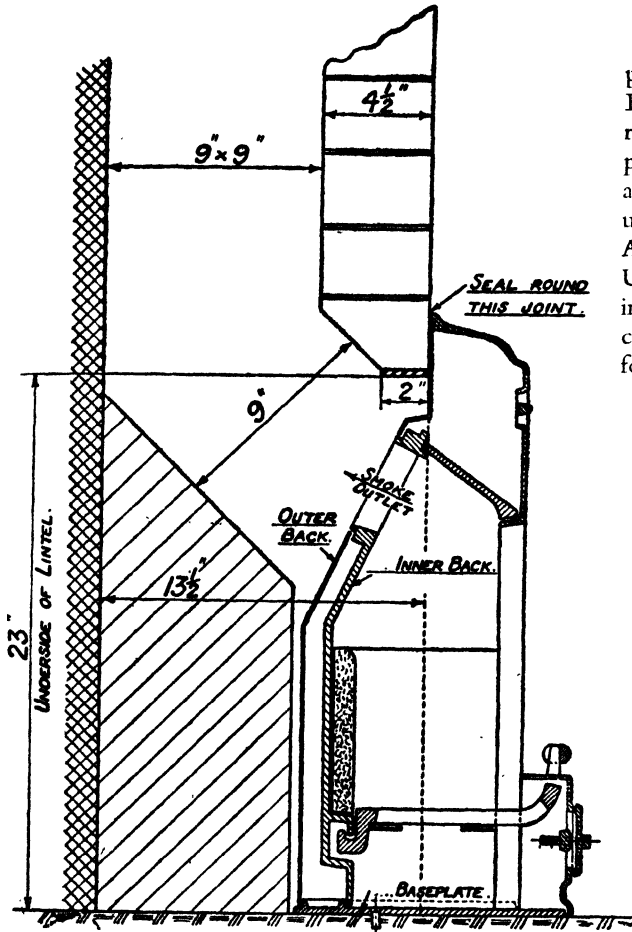
(3) A contemporary design by Grey Wornum, F.R.I.B.A.

unless the industrial designer had been called in at the beginning to collaborate with the heating specialists, foundry technicians and the other experts intimately concerned with the production sequence. He was one of a team of technicians.

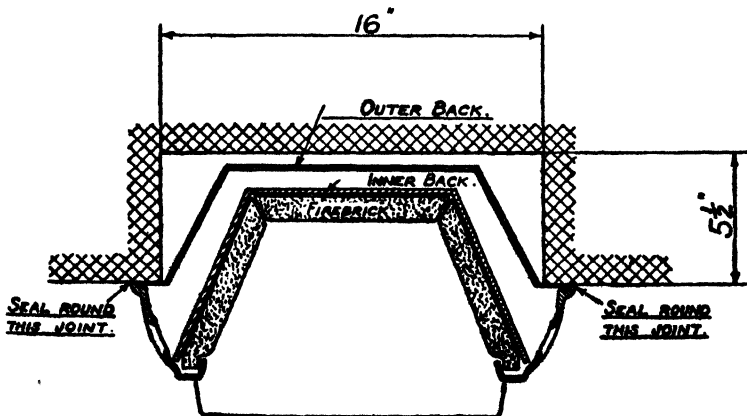
In what way then does the work of an industrial designer differ from that of an engineer who is designing some mechanical article? The difference between the engineer and the industrial designer is in the particular quality of imagination the latter brings to bear upon his work. Occasionally the engineer and the industrial designer are one and the same person: in the nineteenth century some of the greatest British industrial designers were the railway engineers, but they were not identified as such by their contemporaries, nor did they recognise completely their own abilities and responsibilities. Like the fabricator of the "Phaestos Disk" who unconsciously in-



This heating unit is another example of a compact solution to a semi-mechanical problem. It projects from the surface of the wall, covering the aperture that would normally be occupied by the fireplace, and the section and plan on the opposite page show how it is fitted to the fireplace opening and is connected with the flue. It is really a self-contained grate with double casing, which emits warmth on the convection principle. Heat is projected over the whole area of a room, and apertures for the intake and emission of air are visible; those in the lower part of the appliance drawing in cold air, those above giving out warmth. The surface finish is vitreous enamel in black or colour. (These drawings are reproduced by courtesy of Allied Ironfounders Limited.)



Section through the projector heating unit. Below a plan shows its relationship to the fire-place opening. This appliance is marketed under the name of the A.I. Projector Heating Unit. (These drawings are reproduced by courtesy of Allied Iron-founders Ltd.)



vented printing, they unconsciously practised industrial design. They worked in a period that had inherited a great system of design, originally derived from Greek architecture, transmuted first by Roman and then by Renaissance architects and designers, subsequently imposed upon English architecture and the crafts during the sixteenth century, and progressively refined and nationalised throughout the seventeenth and eighteenth centuries. This system of determining the proportions and harmonising the horizontal and vertical elements of buildings had affected the form and ornamentation of nearly everything that was made in that golden age of good design, which lasted from 1660 to 1830. It was partly disrupted by a romantic movement which roused interest in Gothic forms of architecture and ornament; partly by the uneducated taste of a new rich class, and ultimately by the results of the first industrial revolution. The engineer industrial designers of the nineteenth century lived in an age of confused opinion, when "the battle of the styles"—classical versus Gothic—was being fought by architects, and artists were withdrawing their interest from the contemporary world and living a segregated, precious life of their own. So these engineers, who were unknowingly making a new world of forms and rhythms, were humble about their work, almost apologetic about its inartistic character, and this led them occasionally to "apply" some "artistic" trimmings; though they seldom attempted thus to decorate their locomotive machines. The industrial designer did not appear as an independent technician during the first industrial revolution: his functions and subsequent productiveness in partnership with industry have been discussed in detail in another book;⁸ but here it may be said that the type of imagination which differentiates him from the engineer is partly innate and partly the result of training. He is alert, receptive and vigorously creative; he is more inventive and innovating than most technicians, and his ideas are continually refreshed by a variety of problems. He is unhampered by any conscious desire to follow a prototype, though being human he often does so unwittingly, and he never attempts to disguise the industrial origin of his work. The sub-divisions of industrial design given in the previous chapter allow his work to be broadly classified under corresponding headings; thus there are designers of *Shape*, who are concerned with the function, form and finish of industrially produced articles, with or without a static or mobile mechanical function; and designers of *Decoration*, who are concerned with decorative industrial art.

It seems astonishing that these key technicians should have been

THE OPERATION OF INDUSTRIAL DESIGN

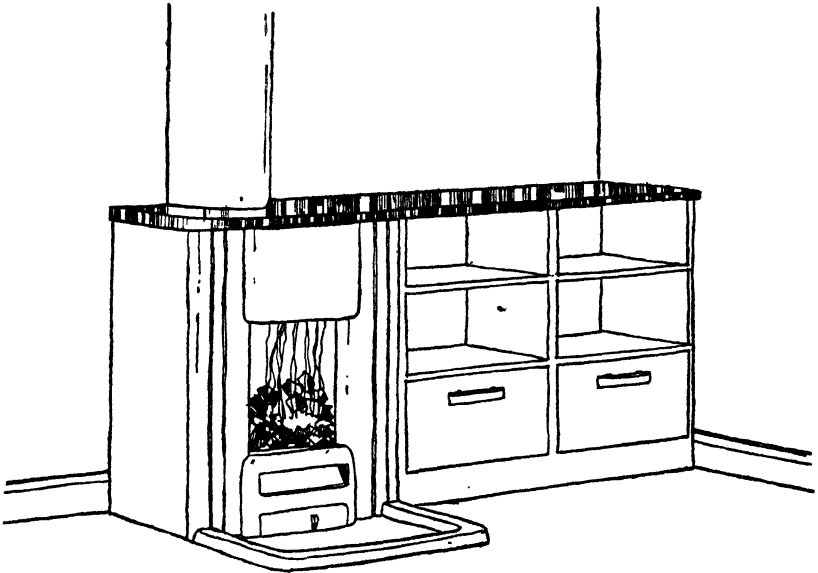
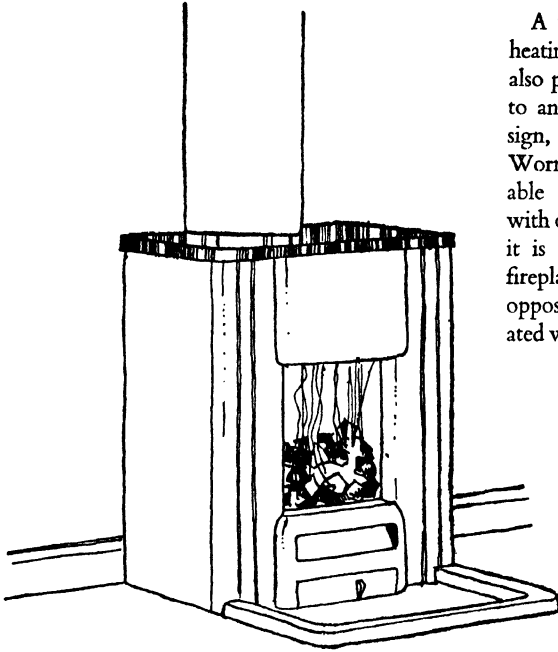
omitted from the structure of nineteenth century industry; but their absence was almost unnoticed. There was plenty of criticism of industry, but it was nearly always peevishly unconstructive, and led to escapist handicraft revivals and intensified the dislike of creative minds for the characteristic achievements of their own time. Some discerning writers saw that something was missing and said so; but few listened. It was more agreeable to read the opening lines of the prologue to *The Earthly Paradise*, and to follow the directions of the poet and craftsman who wrote them.

“Forget six counties overhung with smoke,
Forget the snorting steam and piston stroke,
Forget the spreading of the hideous town;
Think rather of the pack-horse on the down,
And dream of London, small, and white, and clean,
The clear Thames bordered by its gardens green. . . .”

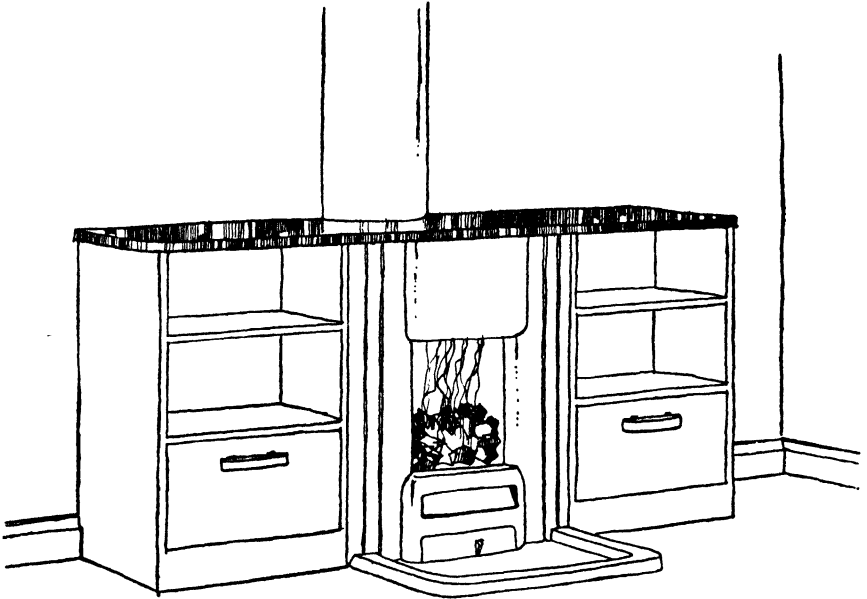
Who could believe that “the snorting steam and piston stroke” were helping to produce a new form of art when hardly anybody recognised or understood the operation of design in industry?

INDUSTRIAL ART EXPLAINED

A unit fire-place for space heating and hot water, which also provides convective heat to an upper floor. The design, which is by Grey Wornum, F.R.I.B.A., is capable of various associations with other fittings. To the left it is shown as a projecting fireplace: below and on the opposite page it is incorporated with bookcase cupboards



THE OPERATION OF INDUSTRIAL DESIGN



The outer casing of the flue which carries the warm air is of enamelled steel; the sides and front of the stove are enamelled cast iron, and the bookcase cupboards may be in wood or pressed steel. (See drawings on opposite page.) The design has been based on some of the experimental development work conducted by the British Coal Utilisation Research Association. The fire consumes 75 per cent of its own smoke, remains in use without refuelling for eighteen hours, and the ashpan needs emptying only every two days. Here the designer has solved a complex technical problem in association with heating specialists.

THE INFLUENCE OF ARCHITECTURAL
TRADITION ON INDUSTRIAL ART

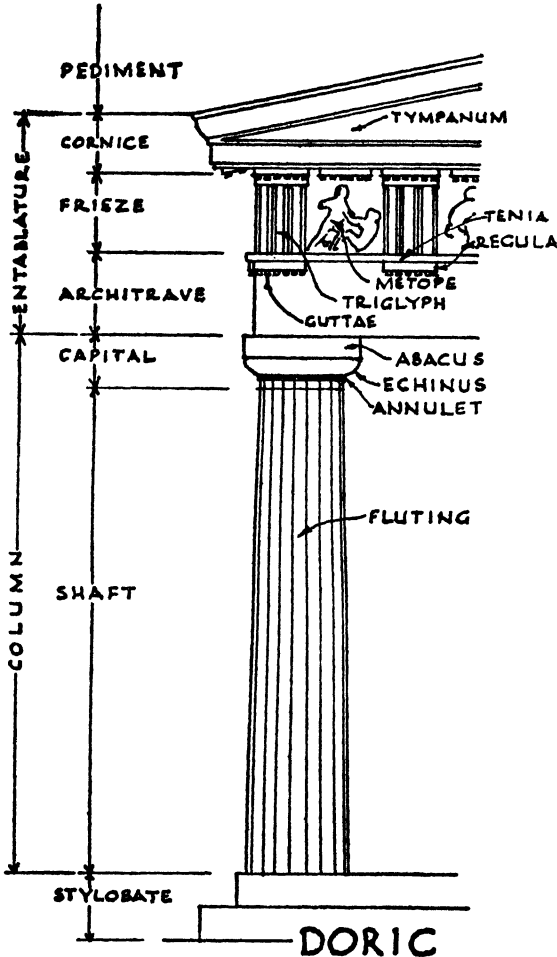
No study of industrial art, no attempt to follow the history of design in industry, would be fully intelligible without an appreciation of the influence of classic architecture. The ramifications of that influence in the period when industrial art was arising had affected the form and suggested the ornamentation of almost every building and article of use. Architecture has been well named "the Mistress Art" for it illumines the practice of all arts and crafts in great periods of civilisation: its principles then pervade the ideas of designers and inspire the imaginative genius, establishing standards of taste that are universally understood and accepted. It is to Greek civilisation that we owe the origin and perfection of those systems of design which are known as the "orders" of architecture.

The character of architecture has developed, and its forms have changed, as a result of three structural discoveries, of which the first was made at some far-distant time. Men found "that two upright posts could support a horizontal member; and from this has arisen what is known variously as post-and-lintel, post-and-beam, or trabeated construction. It is the basic principle behind most of the building that is still done in the world today, for walls are really prolonged posts, vertical masses that support horizontal members, which carry floors and roofs. The second discovery was the arch, and from this arose arcuated construction. In both these methods of construction, buildings were held up chiefly by their walls, which gave them, like crustaceans, a strong external structure. The use of the arch enabled large spaces to be spanned without intervening supports, and allowed great masses of stone to be carried aloft, their weight being spread downwards by curved paths to walls and piers. The third discovery changed buildings structurally from crustaceans to vertebrates, for the invention of the cantilever principle and the increase of metallurgical knowledge led to the use of an internal skeleton of steelwork that was self-supporting, and from which thin walls could be hung, for they were no longer required to hold up floors and roof."¹

The Greeks brought to that first structural method a refinement of proportion and surface treatment and a sense of unity that represented something unique in art. No one who has seen Greek architecture can ever forget its faultless precision—the ordered flow of light and shadow, held by its vertical and horizontal elements and used at every hour of the day to compose some fresh harmony of form. “To turn from the work of other races to Greek work is to find the sense of sight placed in a position of authority it has never before or since occupied, and its most subtle predilections analysed and provided for in a way utterly incomprehensible to any other people,” wrote Lisle March Phillipps.² He added that it was “really like coming under the influence and watching the operations of a new sense.”

Greek architects designed their works to correct all those infinitesimal defects that appear to the eye in regular arrangements of vertical and horizontal elements in a building. For example, a long horizontal line which is perfectly straight appears to sag in the middle, and to grow slightly concave when it is seen full face. A Greek temple is built with an immense number of carefully calculated irregularities, only to be discovered by exact measurement, which are designed to create an appearance of absolute regularity, thus presenting the *actual* shape of the building, which the human eye would never otherwise perceive. The presence of these delicate modulations of line and surface was revealed when the Parthenon was measured in elaborate detail by F. C. Penrose in the 'sixties of the last century. Sight, as Lisle March Phillipps pointed out, was “the governing factor in the undertaking. The real shape of the thing did not matter; it was the apparent shape that mattered. Equal columns which appeared unequal would be made unequal to appear equal. A level floor which looked unlevel would be made unlevel to appear level. Vertical lines which appeared to slant would be made to slant that they might appear vertical. Among other races the eye has been called upon to adjust itself to facts. With the Greeks the facts are, with infinite pains, adjusted to the eye.”

Although they scorned to employ their scientific knowledge for practical convenience or mechanical purposes, the Greeks applied it to the service of art; and having analysed an optical illusion, they used their mathematical skill to correct it, and with stupendous labour and cost wrought their temples so that every stone was cut to secure some deflection of line or surface, which might only represent a few inches in a horizontal feature that extended for two or three hundred feet, but was deliberately calculated and executed.



The classic orders represented a system of design which remained valid and active for over 2,500 years. The Greek orders were: Doric, Ionic and Corinthian. Here they are, the great progenitors of architectural composition, whose influence has dominated Western Europe since the days of Pericles. The Romans produced some variations on these basic orders of architecture. They are shown on pages 44 and 45.

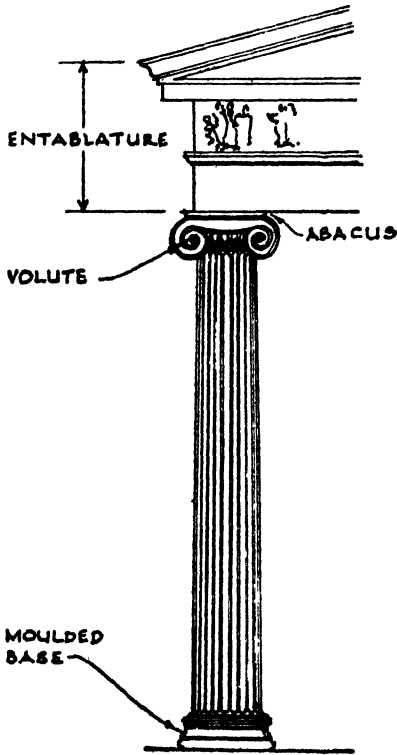
(The drawings on this and the opposite page are from *A Short Dictionary of Architecture*, by Dora Ware and Betty Beatty, A.R.I.B.A., and are reproduced by permission of the authors.)

The visual values of the Greeks have never been excelled, and their "orders" of architecture have in a variety of ways enlightened the work of architects and designers for two thousand five hundred years.

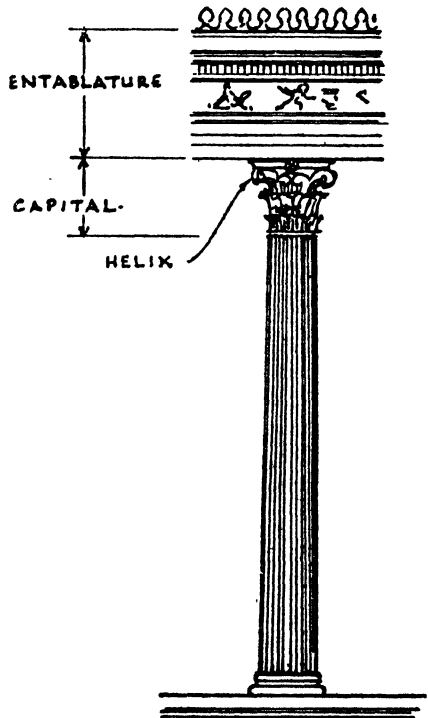
They developed three orders: Doric, Ionic and Corinthian. They have been described as "standardised elements of construction which have not been surpassed."³ One authority has said that "Greek architecture stands alone in being accepted as beyond criticism, and therefore as the standard by which all periods of architecture may be tested."⁴ It is a temptation to accept this comprehensive endorsement of the Greek achievement in architectural design, particularly

THE INFLUENCE OF ARCHITECTURAL TRADITION

when the three orders are closely studied, and the regulation of their rhythms is fully apprehended, for they demonstrate the stature of intellect that chose to express its scientific attainments by composing harmonies in stone. In the presence of such achievements, the Greek rejection of applied science seems less obtuse, though to the modern mind that abjuration is difficult to condone. Some modern scholars and writers have tried to adopt the Greek attitude to the use of science; and the difference between their outlook and the scientific outlook has been responsible for much erudite and petulant criticism. H. G. Wells has described the irreconcilable nature of this difference in an account of his friendship with the novelist, George Gissing. No carefully elaborated attack or defence of one or the other view could be so revealing as the passage in which Wells says: "At the



IONIC



CORINTHIAN

Details of the corresponding Roman orders are illustrated on page 45.

back of my mind I thought him horribly miseducated and he hardly troubled to hide from me his opinion that I was absolutely illiterate. . . . He knew the Greek epics and plays to a level of frequent quotation but I think he took his classical philosophers as read and their finality for granted; he assumed that modern science and thought were merely degenerate recapitulations of their lofty and inaccessible wisdom. The transforming forces of the world about us he ascribed to a certain rather regrettable 'mechanical ingenuity' in our people. He thought that a 'classical scholar need only turn over a few books to master all that scientific work and modern philosophy had made of the world. . . .'⁵

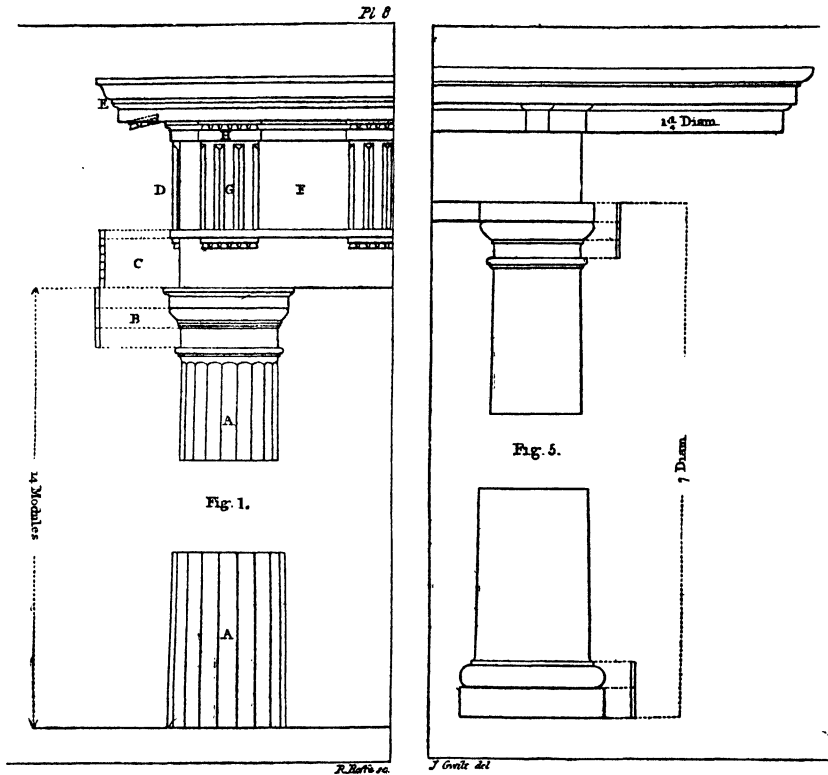
The condition of the world in the mid-twentieth century certainly suggests that the Greeks, by allowing scientific knowledge to be used only in the creation of such masterpieces of architecture as the Parthenon, preserved a quality of life and a continuity of tradition that are unknown in our commercial machine age. Not that the Hellenic world was peaceful; far from it, for there were barbarians east of the Aegean and the totalitarian military state of Sparta nearer home; yet Greek standards, and the Greek gift for identifying art with life, were transmitted to each new generation; and works that had stood perhaps for centuries still spoke a language comprehended and revered by the descendants of their original makers. Even today roofless ruins like the Temple of Poseidon at Paestum, standing neglected and empty in fields of wild flowers and sweet-smelling herbs, calmly reprove our strenuous preoccupations. Those fluted Doric columns and the entablature they support, control sunlight and shadow in order to repeat, day after day, a reasoned statement of stability, still showing men how perfect visual tranquillity was once achieved by architects. Professor Gilbert Murray has said, when discussing the Greek tradition of the fifth century B.C., that no tradition is perfect. "The best brings only a passing period of peace or triumph or stable equilibrium; humanity rests for a moment, but knows that it must travel further; to rest for ever would be to die. The most thorough conformists are probably at their best when forced to fight for their ideal against forces that would destroy it. And a tradition itself is generally at its best, not when it is universally accepted, but when it is being attacked and broken."⁶

The architectural tradition of Greece has often been attacked, though never broken. It has been copied, adapted, misunderstood, abused, glorified and exaggerated, but not abandoned. It has never been an oppressive tradition; it has allowed growth within the regulating framework of its orders, and to those three orders, Doric,

Ionic and Corinthian, we owe the familiar and accepted background of European life, established throughout the Greek and Roman world and restored by the Renaissance, after the Gothic interlude of the Middle Ages. Greek lucidity and love of moderation are illustrated by the temperate use of ornament in all three orders. In each, fluted columns terminated in capitals, which supported an entablature, divided horizontally into architrave, frieze and cornice. The Doric capital was plain, the Ionic was decorated with twin spirals, called volutes, and the Corinthian had smaller volutes rising above a band of formalised acanthus leaves. The variation of surfaces and the emphasising of structural lines with mouldings, the occasional enrichment of mouldings with carved ornament, and the use of sculpture on the frieze of an entablature or the tympanum of a pediment all made some appropriate and reticent contribution to the composition of a building. Ornament was never allowed to disrupt or mask the harmonious relationship of structural elements which the orders represented.

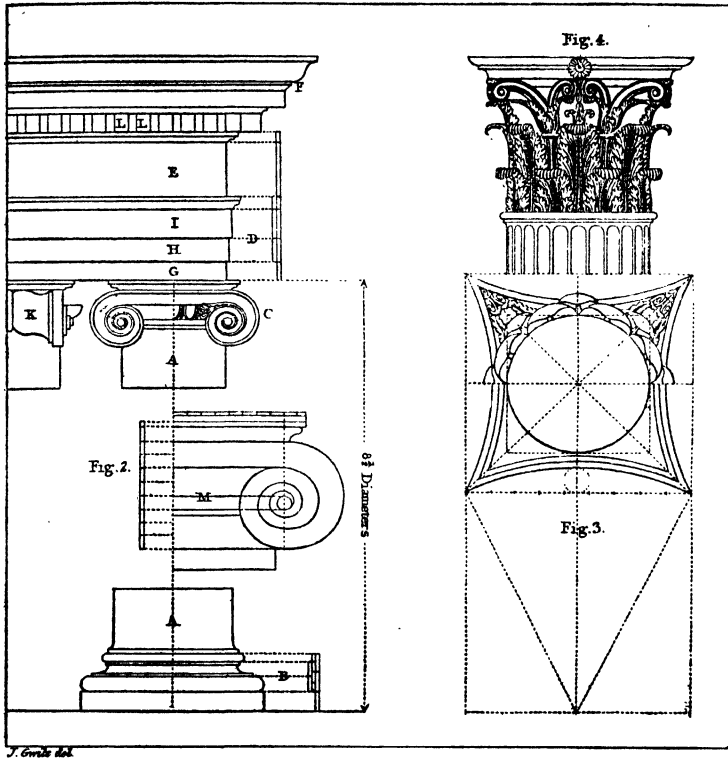
Of all the ornamental devices introduced by the Greeks, the acanthus leaf has become the best known. The acanthus is a native of southern Europe, and the common species, *acanthus mollis*, is called brank-ursine or bears' breech. It has large well marked leaves. Its original use on the Corinthian capital is attributed to a metal worker of Corinth named Callimachus; and the Roman architect, Vitruvius, tells a story, probably apocryphal, about the discovery of its decorative attributes in the fourth book of his work on Architecture. When a certain young Corinthian girl died, her nurse put on her tomb a basket containing a few of the small articles she had been fond of when she was alive. To preserve the contents a tile was put on the basket to act as a lid. "The basket was accidentally placed on the root of an acanthus plant, which, pressed by the weight, shot forth, towards spring, its stems and large foliage, and in the course of its growth reached the angles of the tile, and thus formed volutes at the extremities. Callimachus, who for his great ingenuity and taste was called by the Athenians Catatechnos, happening at this time to pass by the tomb, observed the basket, and the delicacy of the foliage which surrounded it. Pleased with the form and novelty of the combination, he constructed from the hint thus afforded, columns of this species in the country about Corinth, and arranged its proportions, determining their proper measures by perfect rules."⁷

However its use originated, the acanthus leaf has spread all over Europe in stone; it was omnipresent in the cities of the Roman Empire, it reappeared at the Renaissance, and from the sixteenth



The Roman orders of architecture were: Doric, Ionic, Corinthian, Composite and Tuscan. Above, on the left, is the Roman Doric order. The Tuscan, which is a simplified variant of it, is shown above on the right. On the opposite page the Ionic and Corinthian orders are illustrated. The Composite order was an ornate combination of Ionic and Corinthian, profuse and vulgar and popular, and was used for triumphal arches, and other monuments to the prevailing bad taste of the Roman Emperors. "The Romans," writes Sir Banister Fletcher, P.P.R.I.B.A., "never seem to have been satisfied till they had loaded their monumental buildings with every possible ornamental addition." (*A History of Architecture on the Comparative Method*, Section on Roman Architecture.) The Composite order had less influence than the other four upon European architectural design, and very little on English architecture.

(The illustrations on these two pages are from plates in Joseph Gwilt's translation of Vitruvius, published in 1826.)



Compare this Roman Ionic (left) and Corinthian (right) with the corresponding Greek orders on page 41. On both Greek and Roman Corinthian columns, the capitals are adorned by acanthus leaves, a form of ornament that became universal in the towns, cities and settlements of the Roman Empire. From Chester to Jerusalem, from the Rhine to the Sahara, the acanthus sprouted in stone, ubiquitous, unvarying, implacably unimaginative. The influence of this particular ornament has been immense. Revived at the Renaissance, when the classic orders of architecture were re-established, the acanthus curled and sprawled everywhere: appearing on the edges of tables, on the cornice mouldings of tall state beds, in the delicate pearwood carved work of such master craftsmen as Grinling Gibbons when, under the direction of Sir Christopher Wren, he embellished the interior woodwork of St. Paul's Cathedral, on the mahogany knees of early Georgian chairs, on furniture designed and made by Thomas Chippendale. As a piece of "applied" or cast ornament, it helped to confuse ideas about industrial design in the early nineteenth century.

century to the nineteenth it was the most widely used form of ornament. In Greek hands it retained a feathery delicacy, and was employed with restraint; in Roman it became extravagant in form and was used with lavish vulgarity. The three orders were adopted by the Romans, who added two others, the Tuscan and the Composite. The former was a version of the Doric, with unfluted columns rising from a base to a simple capital and entablature. The Corinthian order, seldom used by the Greeks, was the favourite order of the Romans, and they produced an elaborate variation of it, with capitals which combined Ionic and Corinthian features. This was the Composite order: restlessly ornate, overcrowded with ornament and permanently vulgar.

To the Romans came the opportunity of using the arch—the second structural discovery that has influenced the character of architecture. Although they adopted this invention, which may have originated with the Etruscans, they used it only as a structural convenience; they did not inspire a new system of design based on the arch. Instead, they used their versions of the orders to impose a standardised architecture on the towns and cities of their Empire. The ruins of Viroconium in Shropshire, the sand-shrouded remains of cities that once lay like white flowers along the Mediterranean littoral in the provinces of North Africa and Asia Minor, the excavations of Pompeii and Herculaneum, all yield up evidence of a universal tyranny in design, which everywhere stifled native expression in art. The temples and tombs, the altars, triumphal arches and monuments, government buildings, palaces, bridges, aqueducts—even the private houses—are of a recognisable pattern. The rules for architecture were inflexible; they were used from Chester to Jerusalem, from the Danube to the Libyan Desert, to symbolise the magnificence and stability of Rome. Beyond the Roman roads were barren sands or barbarian darkness: within the Empire were law, order, a common language and currency, organised industry, standardised forms for nearly everything—for buildings, furniture, vehicles, armour, weapons—and those forms were unchanging. They lasted for centuries, unlit by any rebellious flicker of imagination, save in outlying and imperfectly civilised provinces like Britain, where now and then a little native talent ventured to make some unorthodox experiment in sculpture. For example, the Romano-British stone heads from Corbridge in Northumberland have, in the words of Mr. T. D. Kendrick, “a directly stated barbaric tensity and beauty.”⁸ There were other instances of revolt against the purely naturalistic standards of Roman art, and some of them,

like that notable piece of sculpture, the Corbridge lion, anticipate the vigorous spirit of mediaeval art. But such resistance to Roman rules for design and decoration was rare. The intimidating comprehensiveness of those rules is shown in the ten books of Marcus Vitruvius Pollio, an architect who dedicated his work to the Emperor—it is conjectured that he lived in the time of Augustus—and laid down exactly what had to be done with every architectural problem likely to arise in public or private life. Nothing moved or grew within the rigid framework of standardised Roman design, and in Britain we have inherited only commonplace ruins and a good road system from our four centuries of inclusion in the Western Empire.

Eleven hundred years after the province of Britain was conquered by barbarians, the Roman orders returned. In that interval a rich national architecture had developed in England, and great skill had been attained in the working of wood and metal. Craft guilds had established standards of practice, which elevated to the highest levels the execution of work in every branch of building and in other trades. At the close of the fifteenth century churches and great religious establishments, palaces, both ecclesiastical and secular, the spacious manor houses of country gentlemen and the town houses of wealthy merchants, demonstrated, by their contents and decoration, the vitality of English arts and crafts, and the splendour and structural achievements of that last phase of Gothic architecture, the Perpendicular. For the first time since the days of the Roman province, the country was peaceful and well-governed, the need for fortification had disappeared, and architecture and its subsidiary arts enjoyed the patronage of new and growing wealth derived from flourishing trade.

This was the state of architecture in England, when the Renaissance was spreading throughout Europe those tentative lambent enthusiasms for the work of antiquity, which were eventually to restore Roman rules of design to pre-eminence in the country, after a century of misunderstanding. About 1486 an edition of Vitruvius had been printed in Rome; others were published in 1496 and 1497, while nine were issued during the sixteenth century. These were in Latin, but in the same period two French, two German and seven Italian versions were printed. Everywhere in Europe Roman architecture was re-establishing its regulations, but for the first time its orders were being interpreted by men whose minds were more active and innovating than Roman minds. The Renaissance was more than a revival of ancient learning and art; it was the reawakening of the European intellect which had been in abeyance for centuries.

The Roman orders were reintroduced to England as a fashion. Throughout the sixteenth century increasing attention was paid by the nobility and gentry to these modish architectural trimmings, for that is how they were regarded: nobody seemed to recognise that the orders represented a system of design, which delineated the proportions and controlled the position of every feature and the profile and enrichment of every moulding. "The simplicity of the early Tudor period, when the spirit of mediæval building craftsmen was still alive and active, was forgotten; Gothic architecture was dying out. The bold, clean lines of the brick and stone houses that were built in the first quarter of the sixteenth century, were no longer visible; they were hidden beneath tortuous stone fretwork, columns and pilasters—all the standardised features of Roman architecture, which were applied to the outside of houses. But they were only *applied*: they were not an essential part of the process of house building, nor were they willingly adopted by the builders. English craftsmen disliked such foreign fashions: they were out of sympathy with the taste that encouraged them. The foreign models and patterns that carpenters, plasterers and stone-masons were expected to copy, became strange, uncouth and almost monstrous in their practised but unwilling hands."⁹

The half century between 1580 and 1630 was an age of confusion in design; but after that time the true significance of the Roman orders was gradually appreciated, alike by architects and their patrons. This was due almost entirely to the work of Inigo Jones, the architect whose genius was recognised and encouraged by both James I and Charles I. He was the first interpreter of the classic orders in England. He was born in 1573, and at first his work was confined to designing settings for the masques in which the Court of James I delighted. He had studied in Italy, and had observed not only Roman remains but the living work of men who had restored the classic orders to European architecture. "He had seen that such architects as Filippo Brunelleschi had not only resurrected Roman architecture, but had granted it a fuller and finer life. For over two hundred years the Renaissance had been blossoming in Italy; and although its flowers had become florid, abundant evidence remained of the splendour and coherence that had marked its growth.

"It was in the work of Andrea Palladio that Inigo Jones found a subject for special admiration. It possessed a quality of reticent stateliness that engaged his respectful attention; it was in the classic tradition, and the clarity of its lines was refreshing after the ornate

confusions of the contemporary Italian architecture that he encountered. Palladio had died in 1580, and Inigo Jones devoted some time to the study of his buildings at Vicenza. It has become a conventional assumption that Inigo Jones owed much if not all of his inspiration to this source; but although he was influenced by Palladio, all that was best in the work of the earlier Renaissance architects and in the remains of antique buildings contributed to the education of his fancy, and with the depth of perception that had been the peculiar gift of the Italian makers of the Renaissance he used Rome's forms and avoided Rome's inflexibility. He brought to England a true understanding of those forms."¹⁰

Without the example of his work, the conflict of ideas which produced so many unhappy, muddled shapes in the late sixteenth century might have been prolonged. "He was the great progenitor of the urbane and ordered beauty that distinguished English architecture and all the arts and crafts that served it for two hundred years. He was more than an understanding interpreter of the antique: he was an architect of rare genius, a master of composition, and his buildings proclaimed their national character in emphatic contrast with the attempts to anglicise Italianate fashions that had occupied his contemporaries and immediate forerunners. There is all the difference in the world between reciting the alphabet and spelling words with it; and Inigo Jones not only learned how to make words, but had something to say, a great lesson to impart, a doctrine of unity and order to establish."¹¹

After the masterly interpretation of the classic orders made by Inigo Jones for the benefit of his countrymen, English architects were never again intimidated by Roman rules. They became thorough masters of this system of design, and they attained a freedom of expression and invention that would have shocked the card-index mind of Vitruvius. Early in the seventeenth century, Sir Henry Wotton published a paraphrase of Vitruvius called *The Elements of Architecture*, wherein he stated that "well-building" must fulfil three conditions: "Commodity, Firmness and Delight." The Roman obsession with grandeur had generally excluded delight.

Architectural knowledge and competent instruction about the proportions and details of the orders at length reached everybody—patrons, designers and craftsmen. After the Restoration of Charles II the great period of design began—that Golden Age which endured until 1830. During that time England produced many architects of genius. Architectural education had made such progress that everybody understood the orders and the system they represented.

Even in Sir Christopher Wren's day, it was possible for craftsmen to interpret designs which a hundred years earlier they would have misunderstood or resented. It has been said that "Wren directed craftsmen all trained to work in one formal language; a slight sketch from the master was enough to set them off, and most of them could and did originate designs for his approval."¹²

By the beginning of the eighteenth century, the system of design that was now so thoroughly understood, was being universally employed. The design of coaches, ships' lanterns, door knockers, iron railings and gates, clock cases, furniture of every description, chandeliers, candlesticks, silver cream jugs, sugar bowls, salt cellars,—indeed, the form of everything reflected ideas which first found expression in Greek civilisation and which now enjoyed a new injection of genius from English minds and English craftsmen. The Romans distorted and petrified the forms that had carried those ideas: in Georgian England they sprouted afresh.

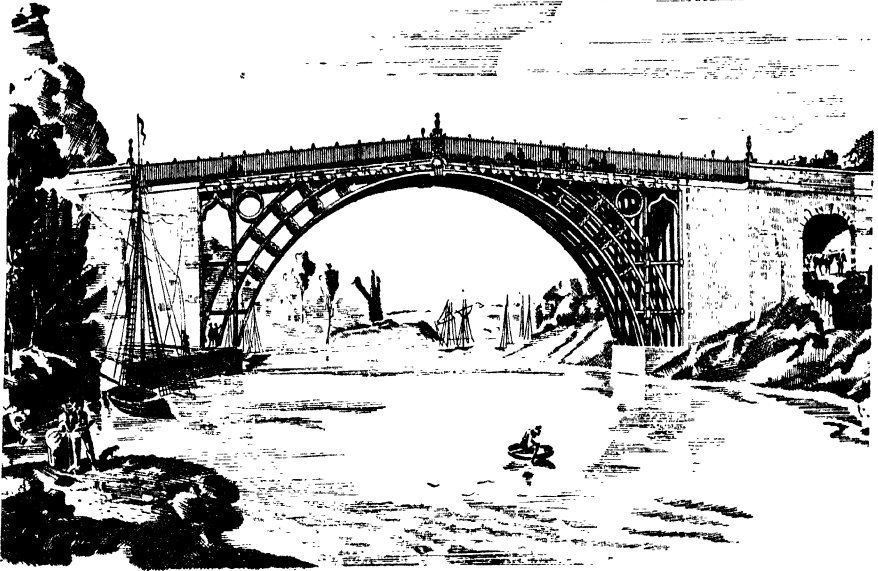
We have intentionally traced the growth and development of this system of design from its origins in Greece, for its persistence records the continuous identity of European life with Greek civilisation. Although it was the interpreters of classic architecture, great Italians like Palladio, great Englishmen like Inigo Jones and Christopher Wren, great connoisseurs and educators like Richard Boyle, Earl of Burlington, who received the credit for educating taste; without the initial inspiration of Greek architecture, the most remarkable period of English design would have lacked the completeness it attained in the course of a hundred and seventy years. During the eighteenth century, many books and collections of plates were published, which spread knowledge of the principles of design and the rules for attaining correct proportions throughout the whole country, so that even the village carpenter and mason in some remote district would be fully acquainted with the orders of architecture, and able to execute not only the work of some fashionable architect, but the instructions of the local gentry. It had become part of a gentleman's education to understand design, and every new idea, every fresh foible of fashion was accommodated by the all-pervading system. Dutch taste, French taste, Chinese taste, fashions from all over Europe and the Far East, might acquire a fleeting modishness, but they were never permitted to disturb the established observance of good proportion. Even experiments with Gothic forms made by eccentric antiquaries like Horace Walpole, failed to disrupt the system of design or even to embarrass its practitioners. The principles of design, evolved from the study of the classic orders and their

THE INFLUENCE OF ARCHITECTURAL TRADITION

proportions, continued to provide consistent visual satisfaction and delight. Living as we do today in an age of confusion that is in many ways comparable to the late sixteenth century, we can scarcely imagine the completeness, the universality, of good design in the eighteenth century or the profound satisfaction it gave to the eye by its consistency, its inventiveness, its unfettered gaiety, and its complete identification with every branch of life. Into this well-ordered world, dominated by people whose education included a lively and informed appreciation of art and architecture, when men in every walk of life used common sense in judging the shape and performance of all the things they used, a world richly endowed with highly skilled craftsmen and mechanics, came the industrial revolution, which was not recognised as a revolution, and for which no preparations had been made.

That "small handful of remarkable Scots and Englishmen" who so changed the life of their country, inherited a system of design in going order. Naturally their imitators and collaborators attempted to relate what seemed to be the appropriate branches of their work to forms with which they had been familiar from childhood. It was only natural that the surface manifestations of that system of design, its ornamentation, its decorative details, should have been perpetuated, for they were thinking not of change—a word much dreaded in England—but of transition. The principles of design were indeed preserved in some of the early examples of work produced in such new industrial materials as cast iron, which was as stimulating to designers in the late eighteenth century as reinforced concrete and glass and light alloys and plastics have become in our time. In the design of such large scale things as the first iron bridge, which spanned the Severn between the towns of Ironbridge and Broseley in Shropshire, or in such small things as balcony railings, the trained designer was still in control of the situation. He was still the inventive interpreter of a valid and accepted system; he did not have to explain much less apologise or fight for his ideas. Some of the new materials and processes for using them might be novel, but patronage was still educated. That critical nobleman, the Hon. John Byng, who became the fifth Viscount Torrington, could commend the first iron bridge, saying indeed that "it must be the admiration, as it is one of the wonders of the world";¹³ and could discourse with educated judgment upon the architectural merits or shortcomings of the houses he saw on his travels; but the existence of the industrial revolution escaped him, though he observed with an almost Victorian warmth of approval the effect of the adjacent iron foundries and

INDUSTRIAL ART EXPLAINED



The first iron bridge at Coalbrookdale, Shropshire. It was designed by Thomas Farnol Pritchard, a Shrewsbury architect, and constructed by John Wilkinson and Abraham Darby, and was cast and erected in 1779, by the Coalbrookdale Company. It is still standing, and has been scheduled as a national monument. The trained designer was still in control of the situation, and the form of this first bridge has an affinity with the classic tradition of design, although it is executed in what was then a novel material.

(This drawing is based on a steel engraving made in 1782, in possession of the Coalbrookdale Company.)

manufactures on such towns as Broseley “which bears all the marks of content, increase, and riches, not owing only to the iron business, but to a most flourishing pottery and porcelain manufactory.” Again, in the Forest of Dean he remarked the frequency of the iron furnaces “whose smoke impregnating the air, felt to me very wholesome and agreeable.”¹⁴

When the Hon. John Byng was making his pleasantly unhurried tours of the country, industrial enterprises were generally housed in a familiar and not disagreeable manner. Mills erected then inherited the current architectural graces, even though they were but the plainest statements of need in brick. Some of the best

examples of this early industrial building are to be found today in the Stroud Valley. The architectural tradition in design still controlled the form of nearly every building. It was only when machinery became more complex, and made special and unprecedented demands for accommodation, that the form of factories and the whole character of industrial plant broke away from the existing architectural tradition. The engineer with no architectural training had to provide shelter for the machines under his care.

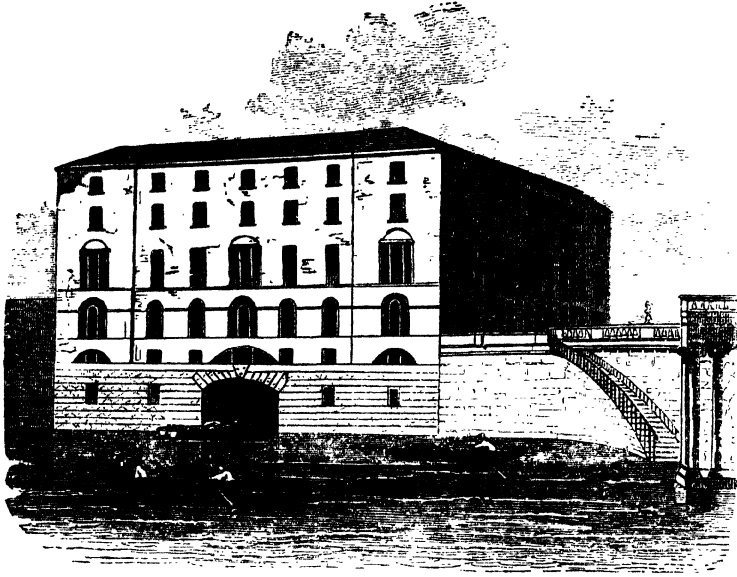
Technical ability in engineering was advancing so rapidly that even in the early factories and shops there was an inclination to accept makeshift arrangements for accommodation in order to allow for expansion, and to allow also for changes in the disposition and character of machinery. An account of the growth of the Soho Factory of Boulton and Watt at Birmingham in the late eighteenth century, given by Erich Roll in *An Early Experiment in Industrial Organisation*, illustrates the reluctance of industrial pioneers to adopt any building programme which was not dependent upon the adaptation of existing buildings and the piecemeal addition of fresh shops. "The Soho building, which was originally used for the manufacture of silver and plated goods, was in the form of the letter E, the wings of which were used as dwellings for managers and foremen. Two yards lay behind it, the first a story lower than the ground at the front, the second still lower. All the additional industries which arose at Soho were carried on in buildings erected in these yards."¹⁵ Factories it seemed were destined to grow untidily as mechanical industry developed.

The growth of industrial districts was equally haphazard and untidy, being both stimulated and circumscribed by the development of transport. In the latter part of the eighteenth century the rapidly growing canal system was continually coiling fresh tentacles into the countryside; industry followed, darkening fields and withering woodlands. As early as 1767 it was decided to link Birmingham by canal with the colliery district near Wolverhampton. "Before the end of the century the whole district was linked together by canals and was joined to the chief waterways of the country as a whole. Besides confirming the flow of trade into the places where they connected, and so emphasising the existing localisation of industry, the canals also had an effect on the actual sites selected for new factories and on the general direction of industrial growth. Foundries, rolling mills and all concerns which used coal and heavy raw materials tended to become established on the canal banks, and this movement was encouraged by the fact that specially low tolls

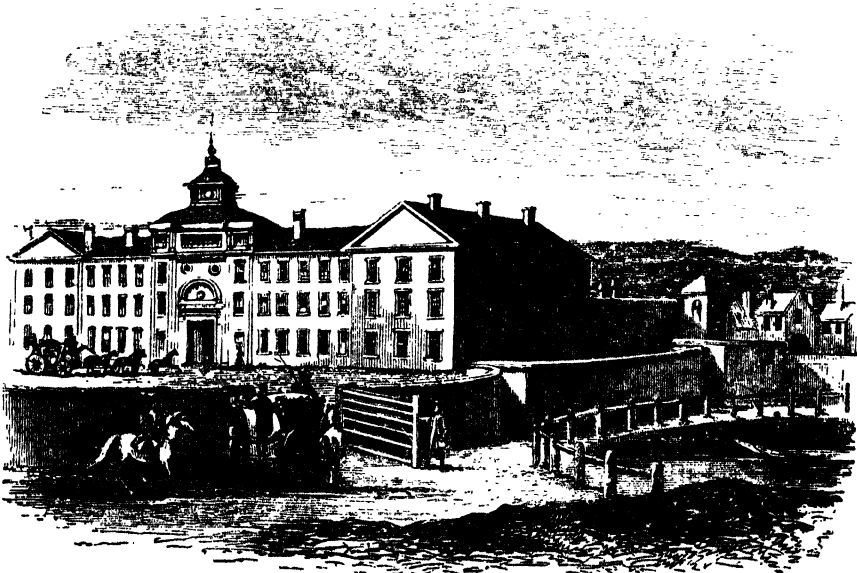
were granted on coal and cinders going to works adjoining the canals. When more use came to be made of the steam-engine, a site on a canal bank became of even greater advantage, for the owners of factories were given statutory powers to take water free of charge for condensing purposes. Consequently, towards the end of the eighteenth century, works began to extend from Birmingham, and from the South Staffordshire towns through which the canals passed, along the banks, until ultimately there came to be a continuous line of factories along the waterway, running from Birmingham through Smethwick, Oldbury, Tipton Green and Bilston to Wolverhampton."¹⁶

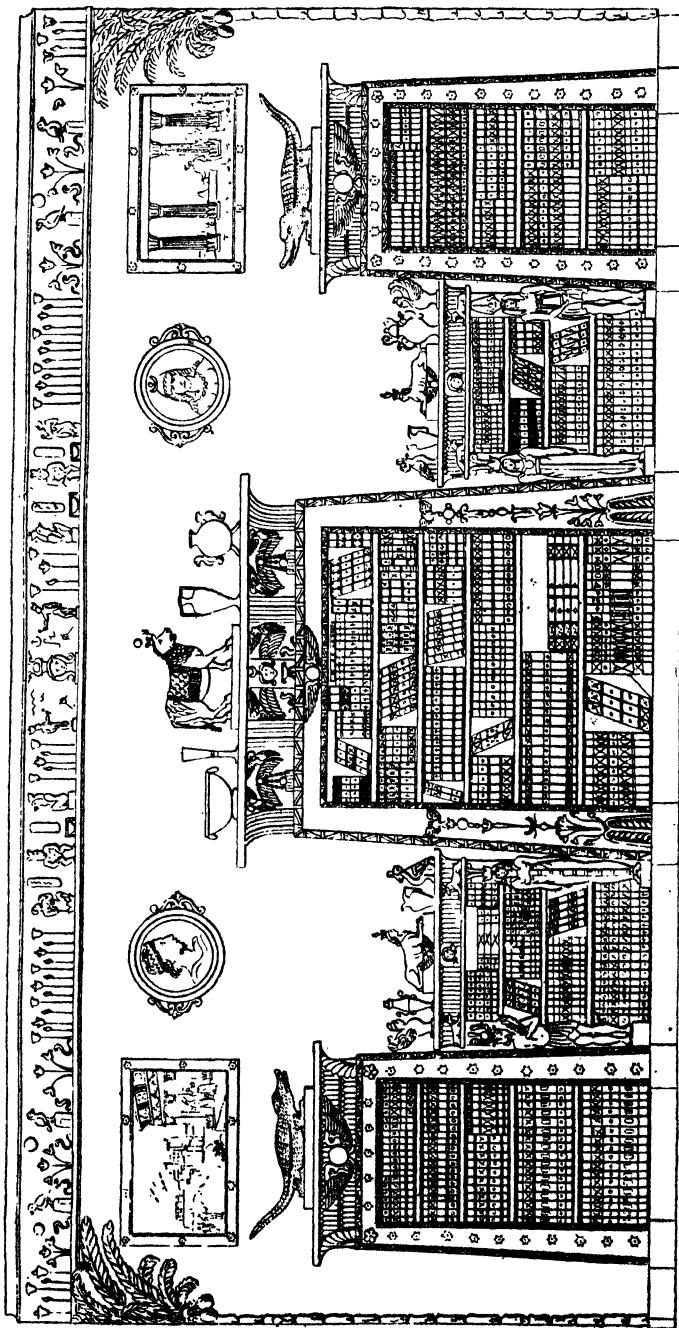
But cultivated ladies and gentlemen, people of taste and fashion, continued to enjoy their abundant leisure gracefully, and if anything worried them, it was likely to be the French Revolution and its awful example to the "lower orders," or, a little later on, the alarming ambitions of the First Consul who had turned himself into an Emperor. They were collectively unaware of what mechanised industry—that new, insurgent force in the land—was doing to the countryside, the people, and their own privileges and established ideas. They ignored the industrial districts, or, like the Hon. John Byng, found them mildly stimulating if they came upon them casually; but even the intrusion of industry into residential areas near London seemed to cause neither alarm nor despondency, if the guide books of the period accurately reflected popular sentiment. For example, Battersea and Wandsworth were quiet Surrey villages in the middle years of the eighteenth century, with some old-established cloth works in the vicinity of the latter. William Hickey in his *Memoirs* describes "a noble house upon the border of the river, a little above the town of Battersea";¹⁷ the locality was famous for the fine asparagus grown in its gardens; and at Wandsworth there were "several handsome houses belonging to the gentry and citizens of London."¹⁸ Fifty years pass, and in addition to works where cloth is dyed—an industry founded in the late seventeenth century by Huguenot refugees—Wandsworth now has "several considerable manufactories" including iron mills, calico-printing works, linseed oil and white lead mills, vinegar works and a distillery. "The Surrey iron railway extending to Croydon is completed to this place, where there is a commodious basin for loading and unloading goods, etc., communicating with the Thames."¹⁹ At Battersea the manor-house, where Lord Bolingbroke had died in 1751, has been largely demolished, and on the site "are erected the horizontal air-mill, and malt distillery of Messrs. Hodgson, Weller and Allaway," while the

THE INFLUENCE OF ARCHITECTURAL TRADITION

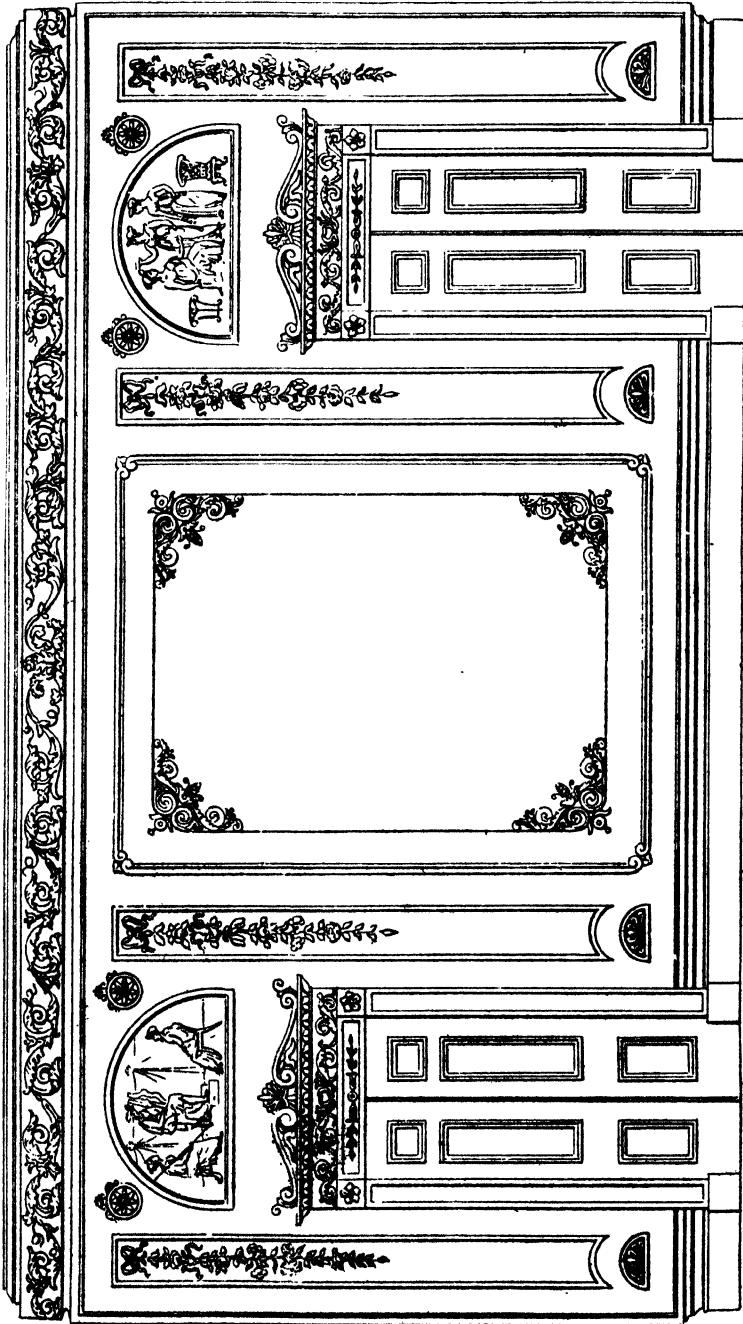


Industrial architecture in the eighteenth century had the orderly and agreeable characteristics of that period. Above: the Albion Mills, designed by John Rennie, and built on the Thames, near the south-east end of Blackfriars Bridge. Below: the Soho Manufactory, occupied by the firm of Boulton and Watt of Birmingham. (From *Lives of Boulton and Watt*, by Samuel Smiles. John Murray, 1865.)





The past was ransacked for ideas, and an interest in Egyptian antiquities had the most deplorable results. The designer of this scheme of interior decoration and furnishing has raided ancient Egypt, and has arranged his assorted loot in a fairly orderly manner. Even the crocodiles are symmetrically disposed. (From George Smith's *Cabinet Maker and Upholsterer's Guide*.)

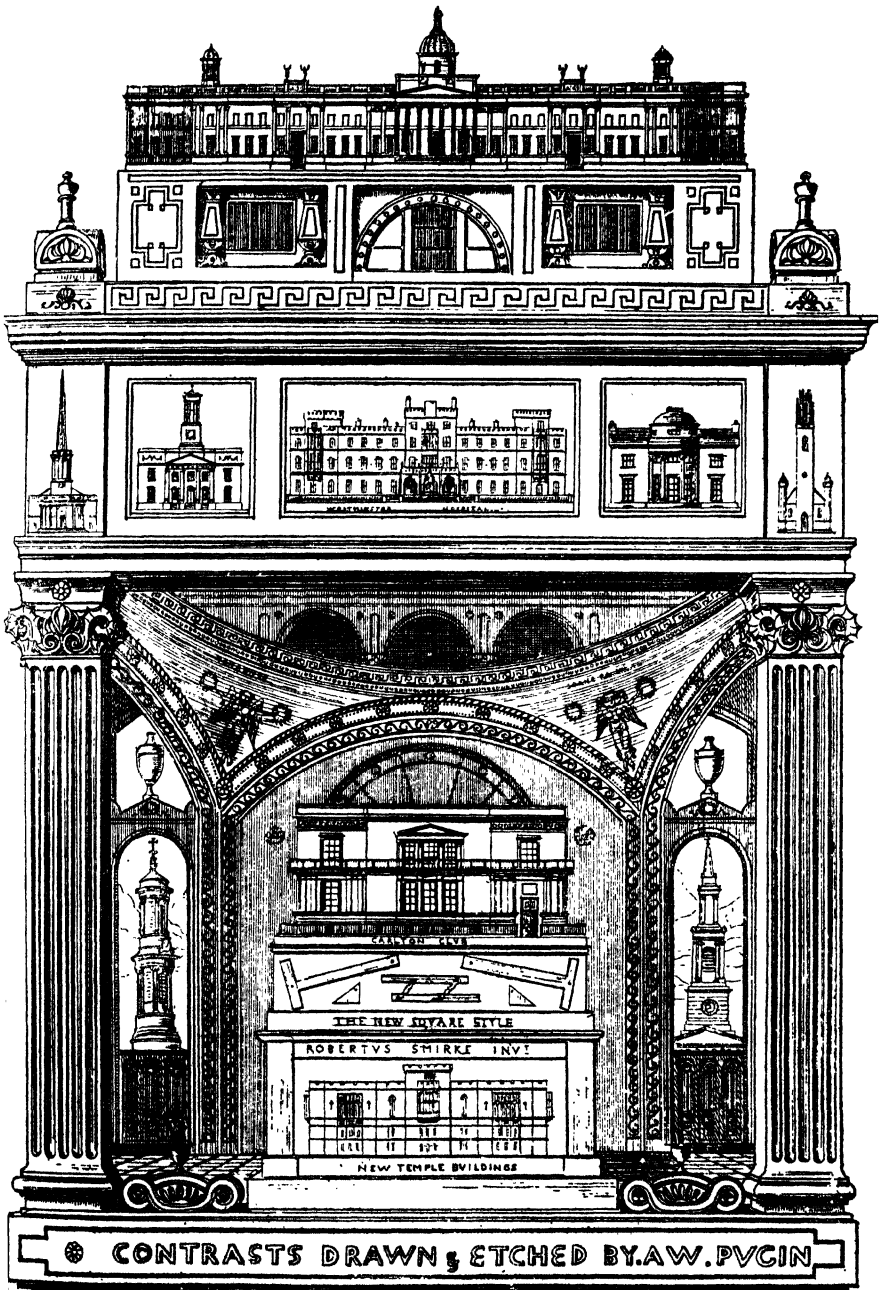


Towards the end of the great period of design, in the eighteen twenties, the classical background became rather overcharged with ornament. Some respect for good proportions was still retained, but there was a tendency to overcrowd everything with ornament. (From George Smith's *Cabinet Maker and Upholsterer's Guide*.)

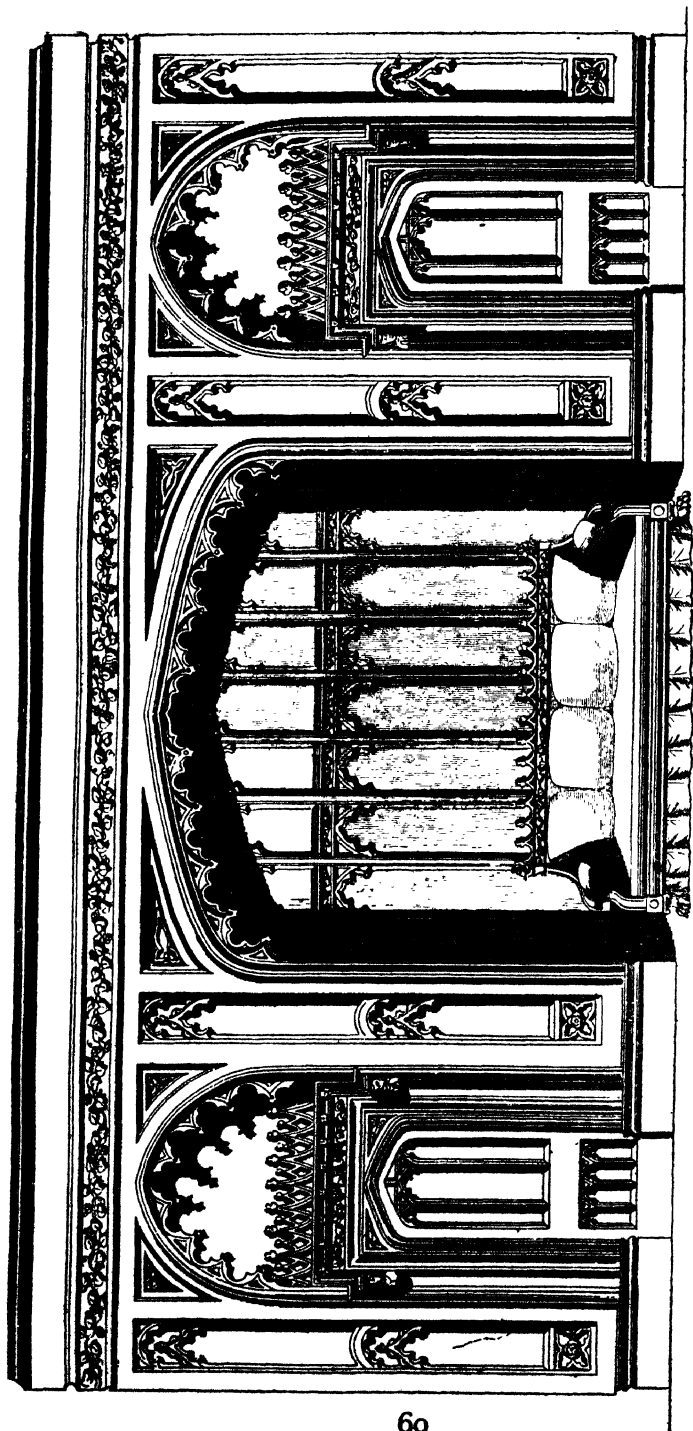
garden and terrace are replaced by "extensive bullock houses, capable of holding 650 bullocks, fed with grains from the distillery, mixed with meal."²⁰ A little way upstream, smoke and the ringing of hammers came from the foundries and forges, and smuts and soot gradually drifted over Battersea from Wandsworth. Industry had won fresh territory: as usual, it was following a waterway, and at Wandsworth it was also served by England's first public railway, which was completed in 1803.

Yet the clamorous advance of the new revolution was missed: the nobility and gentry were listening, a shade anxiously, for other sounds—for the rumble of the tumbrils that took aristocrats to the guillotine at the bidding of the Sovereign People; for the thunder of the invader's cannon. But they had plenty of diversions: new movements in art and architecture and literature were gaining momentum. At first they were under conscious control as fashions; they enjoyed the patronage of the modish world; but they became overcharged with emotion, and those who supported them discarded elegance for earnestness. A romantic movement in literary taste had begun in the early decades of the eighteenth century, and poets and antiquaries between them created an interest in mediaeval art and architecture. (The second chapter of Sir Kenneth Clark's book, *The Gothic Revival*, traces some of the first contributory literary influences.)²¹ This interest produced an atmosphere favourable to experimentation with the forms of Gothic architecture. Nobody suspected when Horace Walpole was embellishing Strawberry Hill with pinnacles or James Wyatt was erecting that magnificent piece of stage scenery, Fonthill Abbey, for his queer but accomplished client, William Beckford, that such an amusing by-way of taste would ever be trampled into a broad road by a vast traffic of devout pilgrims, with their eyes on the past, eager for a promised land of chivalry, handicrafts and Christian brotherhood. "From the first the new taste for Gothic architecture was no more than a symptom of a great change of ideas which we call the Romantic movement," writes Sir Kenneth Clark. "No one can define this change; but any definition must suggest that the Middle Ages took the place of classical times as an ideal in art and letters."²²

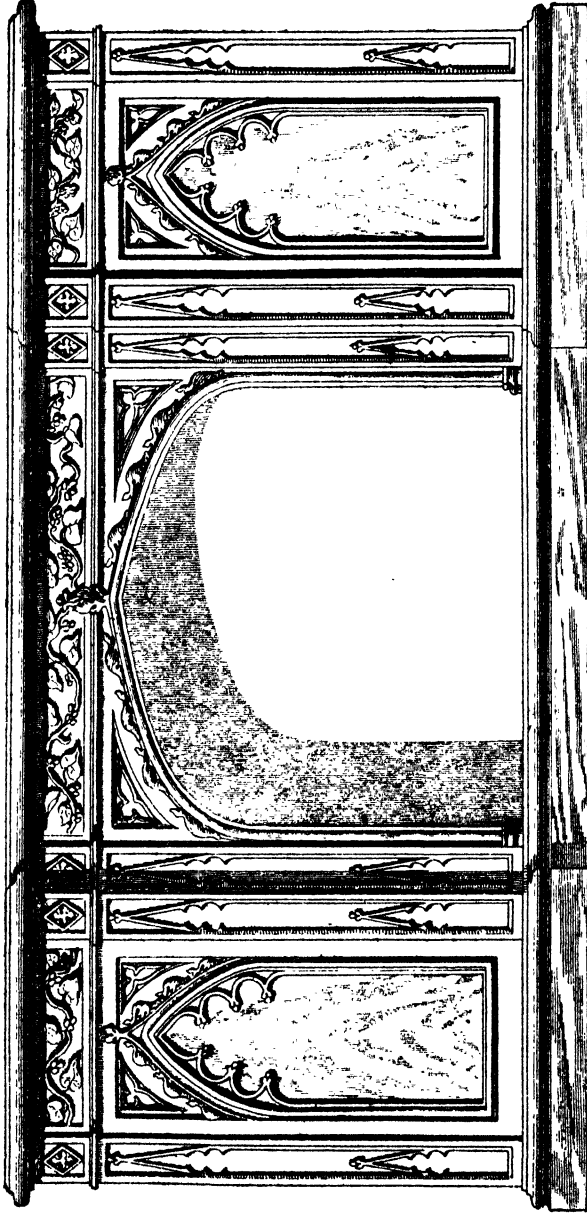
The romantic movement and the industrial revolution developed simultaneously. At first both were accommodated within the frame of the traditional system of design. Without the disruptive influence of the romantic movement, it is at least conceivable that the principles of the system might have informed and improved the products



The illustrated title page of Pugin's book of *Contrasts*, in which he attacked the classic tradition of architectural design and the industrial revolution.



At first the Gothic background had an almost classical orderliness: this was before Ruskin's attacks upon order and symmetry in design had begun to take effect. In this interior in the Gothic taste, the influence of the architect is still apparent. (From George Smith's *Cabinet Maker and Upholsterer's Guide*.)



A Gothic sideboard from George Smith's *Cabinet Maker and Upholsterer's Guide*. Even this example shows how "the discipline of design remained"; for this has none of the exuberant untidiness of the Gothic furniture that came lumbering into the homes of the wealthy in the late 'thirties and the 'forties of the nineteenth century.

of industry. But the opportunity of collaboration between designers and industrialists was missed. Supporters of the romantic movement attacked both the established order of classic design and the disorder of industry.

During the eighteenth century architectural manifestations of the movement were eccentric but well-mannered. They accorded with the prevailing appreciation of the proportions laid down for classic architecture. Batty Langley had even attempted to work out a series of Gothic "orders" and in 1747 published his *Gothic Architecture, Improved by Rules and Proportions, In Many Grand Designs of Columns, Doors, Windows, Umbrellos, Temples and Pavillions, etc., with Plans, Elevations and Profiles, Geometrically Expressed*. But all respect for rules which regulated proportions was swept away by the emotional romanticism of the early nineteenth century. The romantic movement in taste came into unacknowledged, and indeed unconscious, alliance with the Evangelical movement in religion: Gothic architecture gradually became a subject for reverence. The great period of classical design was ending, and its canons were openly and ferociously attacked at first by such Gothic revivalists as Pugin, and later by Ruskin.

Towards the end of the eighteenth century and throughout the early part of the nineteenth there was a Greek revival in architectural design. Scholarly in spirit, it produced some works of great elegance, though it was concerned principally with the correct use of the Greek orders in their original purity of form and detail, and was not a revival of understanding for the Greek point of view. There had been other architectural and artistic revivals; excursions to the past in search of ornamental loot. Even Ancient Egypt made contributions to the decorative ideas of the English Empire period—which was a subdued reflection of the French Empire fashions—and illustrated books and portfolios of plates provided the nobility and gentry and the new rich with a mixed diet of antique styles. But the discipline of design remained until well into the eighteen thirties, and the most incongruous ideas were accommodated and rendered coherent by architects and designers; but they were fighting a losing battle against confusion. The great system of design was attacked, consciously and with thunder and shouting, by the Gothic revivalists, and unconsciously by mechanised industry. Thus a new age of confusion began, and it was thrice confounded by the new industrial power that allowed manufacturers to produce in immense quantities articles whose shape and ornamentation had been copied without being designed. The results were often deplored

THE INFLUENCE OF ARCHITECTURAL TRADITION

by the very people who had helped to destroy respect for the traditional system of architectural design.

In 1836 Augustus Welby Pugin had published, at his own expense, his book of *Contrasts*. It was a pictorial attack on classic architecture and design and on contemporary industrial and social life. It exalted the Middle Ages, and graphically supported the popular tendency to misrepresent the quality of mediaeval civilisation, which had been growing with virtuous intensity since William Cobbett had published his *History of the Protestant Reformation*, in 1824. Two of the plates showed imaginary views of a town, in 1440 and 1840. In the latter, iron-works and gasworks, huge warehouses, grim little chapels, lunatic asylums and so forth occupied the sites of the abbeys, churches, guild-halls and monasteries that had reared their towers and spires in the mediaeval city. Five years after *Contrasts* appeared, Pugin published in book form two lectures he had delivered at St. Marie's, Oscott, entitled: *The True Principles of Pointed or Christian Architecture*. He bewailed the imitative powers of industry, and was outraged by the products of "those inexhaustible mines of bad taste, Birmingham and Sheffield. . . ." He enumerated such architecturally inspired objects as "staircase turrets for inkstands, monumental crosses for light-shades, gable ends hung on handles for door-porters, and four door-ways and a cluster of pillars to support a French lamp; while a pair of *pinnacles* supporting an arch is called a Gothic-pattern scraper, and a wiry compound of quatrefoils and fan tracery an abbey garden-seat. Neither relative scale, form, purpose, nor unity of style, is ever considered by those who design these abominations"; he complained, "if they only introduce a quatrefoil or an acute arch, be the outline and style of the article ever so modern and debased, it is at once denominated and sold as Gothic."²³

Fashions had escaped from control. Pugin thought that the absurdities he described arose "from the false notion of *disguising* instead of *beautifying* articles of utility." Already the idea of "applying" a beauty treatment was abroad; it led in time to "applied art"; but although Pugin was right about the noxious idea of disguising an article, he did not apprehend that he and his fellow Gothic revivalists were partly responsible for the evils they associated with industrial production, not because their taste in architecture had provided models for manufacturers to imitate, but because their beliefs had debilitated confidence in the system that had given England its golden age of design. They destroyed the influence of architectural design, substituted anarchy for order and emotion for intellectual lucidity, rejected the industrial revolution, which they might have

INDUSTRIAL ART EXPLAINED

directed, and turned the minds of artists and designers from contemporary problems to an idealised and largely imaginary mediaeval civilisation. It was not surprising that few, if any, people thought that the words art and industry could ever be associated to represent any creditable activity.

INDUSTRIAL ARCHITECTURE IN THE
NINETEENTH CENTURY

MOST enduring and impressive of all visible manifestations of nineteenth century industrial art was the new architecture demanded by steam-driven factories and traffic. Industrial buildings in the previous century were designed with respect for the principles of architectural composition; but by the end of the Victorian period, the "false notion" which Pugin had denounced was commonly held by builders of factories. Like most other people they thought of architecture as a disguise. To the factory owner, the architect was somebody who hid the work of the engineer. He was placed, distrustfully, in the category of "artist"; somebody whose work had nothing to do with practical needs, who was called in only when you could afford some "frills." So factories were built to resemble Venetian palaces or mediaeval castles; their functional features concealed by the false whiskers of some "style," devised and elaborated on a drawing board, unrelated to the needs of the industrial processes conducted within, and unmindful of the health, convenience and efficiency of the factory workers.

Perhaps the greatest misfortune that befell design in the nineteenth century was the so-called "battle of the styles." The mere title of that unreal and confusing conflict gave a new interpretation to the word "style." The principles of architectural design, so well understood throughout the eighteenth century, were gradually obscured. The study of classic architecture tended to become merely an antiquarian exercise. What mattered, according to critics and writers, was genuine devotion to the antique, so that the accurate reproduction of the orders was considered more important than an imaginative use of the great system of design they represented. It has been said by two authorities on architectural education that the study of the classic in building forms, as in much else, is a training in the appreciation of human values, which leaves the mind richer and freer than other studies leave it; and that the study of classical architecture provides primarily a standard of values, which arises from the best and most universal experiments. "We shall not be

able to humanise steel frame or reinforced concrete construction and make buildings in these or any future material, logical and graceful, by any other essential process than that by which the Greeks long ago humanised marble masonry. We shall have to penetrate, as they did, to the roots of the problem, structural and artistic, and expend thought and talent upon it. Thus, a building most truly 'Greek' in a modern city may have no 'orders of architecture' upon it; it may be nothing more than a steel frame structure harmonised and vitalised, and yet be 'Greek' in spirit."¹

There was some promise in the late eighteenth and early nineteenth centuries that industrial buildings might be "harmonised and vitalised," and that new materials, such as cast iron, would be used with intelligence and imagination. A good beginning had been made with the iron bridge at Coalbrookdale. This experiment was followed by others. In the last decade of the eighteenth century, Thomas Telford built an iron bridge across the Severn at Buildwas, half way between Shrewsbury and Bridgnorth. He was County Surveyor of Shropshire, and had observed some defects in the construction of the Coalbrookdale bridge. Already that first iron bridge had established a prototype for ironmasters, and Telford had some difficulty in persuading the Coalbrookdale iron-founders who undertook the casting of the material for his bridge at Buildwas, to depart from the structural methods adopted for the Coalbrookdale bridge. Telford's bridge "consisted of a single arch of 130 feet span, the segment of a very large circle, calculated to resist that tendency of the abutments to slide inwards which had been the defect of the Coalbrookdale bridge. . . ."²

The span of Telford's bridge was 30 feet wider than the Coalbrookdale bridge, and it contained 173 tons of iron as against the 378 tons of the first bridge. Already a designer of great competence and originality was using to the best advantage a new and promising material. In 1801 Telford produced a design for a cast iron bridge to replace old London Bridge, which had become rickety and dangerous. His design consisted of a huge, single arch, formed by seven cast iron ribs. It was to span the river 65 feet above high water, with a road, 45 feet wide, and was to contain 6,500 tons of iron. The estimated cost was £262,289. A Select Committee reported favourably upon the project, which was abandoned only because it demanded such sweeping and costly clearance of existing property to secure the necessary approaches.

Many iron bridges were built between the closing decades of the eighteenth century and the middle of the nineteenth; but the most

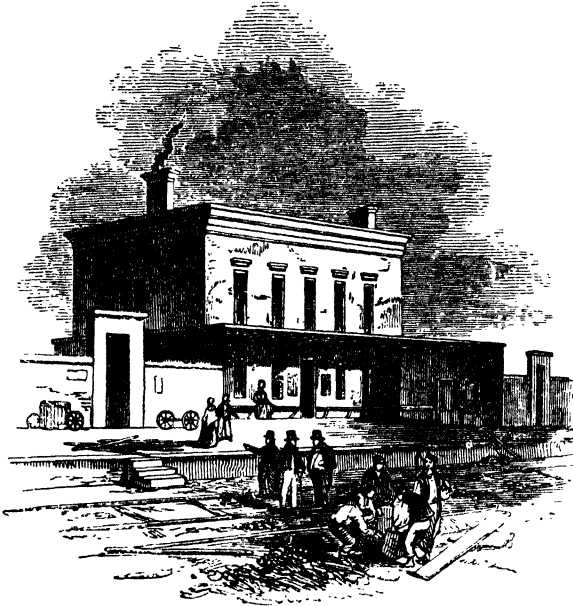
inventive architectural uses of cast iron were Decimus Burton's design for the Palm House at Kew Gardens and Sir Joseph Paxton's Crystal Palace, for the latter was the first large scale, successful example of pre-fabricated building. John Nash used cast iron, and in his biography of George IV's architect, John Summerson suggests that Nash's connection with Broseley and the probability of some of his relatives living there, gave him intimate knowledge of cast iron technique in the foundries of Coalbrookdale and Bersham.³ But Nash never apparently regarded cast iron as an independent material; to him it was a novel, cheap and convenient substitute. He thought of it as many manufacturers, and some designers, first thought about plastics. For example, in his design for a "plate iron" bridge, he "merely substituted cast iron boxes, made of iron plates bolted together, for voussoirs"⁴ and those boxes were to be filled with earth, sand, stone or gravel, to give them weight and solidity. He used cast iron columns for Buckingham Palace and for the Regent Street arcades; they were inexpensive substitutes for stone. Other people discovered how cheaply and easily iron could be cast for conventional architectural features, both classic and Gothic, and the multiplicity of such cast iron ornaments for churches brought down upon iron-founders the thunderous denunciations of Pugin.⁵ Nobody took much notice; the early promise of productive partnership between designers and iron-founders had faded even before Paxton made his notable experiment in pre-fabricated units of cast iron and glass. Thus one of the new materials which might have helped designers to produce a distinctive form of architecture, characteristic of the industrial age, was first misused and then largely disused, as other structural materials replaced it, and its early forms were forgotten.⁶

Not only did new materials and the new structural inventiveness they evoked furnish opportunities for designers to develop fresh forms and to reinterpret the principles of design, but the hitherto unimagined needs created by that outstanding nineteenth century achievement, the railway, provided stimulating problems that demanded trained imagination as well as technical skill. The early architecture of the railways, like that of the early industrial buildings, preserved its connection with tradition. The first railway stations were designed unpretentiously; they were perfectly fitted for the function they had to perform; but soon they became influenced by the "battle of the styles," which disturbed their functional character and tricked them out in the most unsuitable costume. This aspect of industrial architecture did not escape criticism; but the

critics generally wrote or spoke from the point of view of one or other of the protagonists in the battle of the styles. A railway station, for example, that retained a classical elegance of design, would be ruthlessly condemned, almost branded as immoral, by a Gothic Revivalist, who had read his Ruskin and had taken to heart the winged words which dismissed the classic orders and all the architectural works of Greek and Roman antiquity as visible evidence of an improper and subversive paganism. In *The Stones of Venice*, Ruskin had said: "Whatever has any connection with the five orders, or with any any one of the orders; whatever is Doric or Ionic or Corinthian or Composite, or in any way Grecised or Romanised; whatever portrays the smallest respect for Vitruvian laws or conformity with Palladian work—that we are to endure no more." Ruskin told his eager readers and listeners that he had no doubt that "the only style proper for modern northern work is Northern Gothic of the thirteenth century."⁷ He condemned the Renaissance as "a foul torrent." He urged people not to be afraid of incongruities. "Do not think of unities of effect," he said in his passionate advocacy for Gothic architecture. He told the world to remember "that it is the glory of Gothic architecture that it can do *anything*. Whatever you really seriously want, Gothic will do it for you; but it must be an *earnest* want."

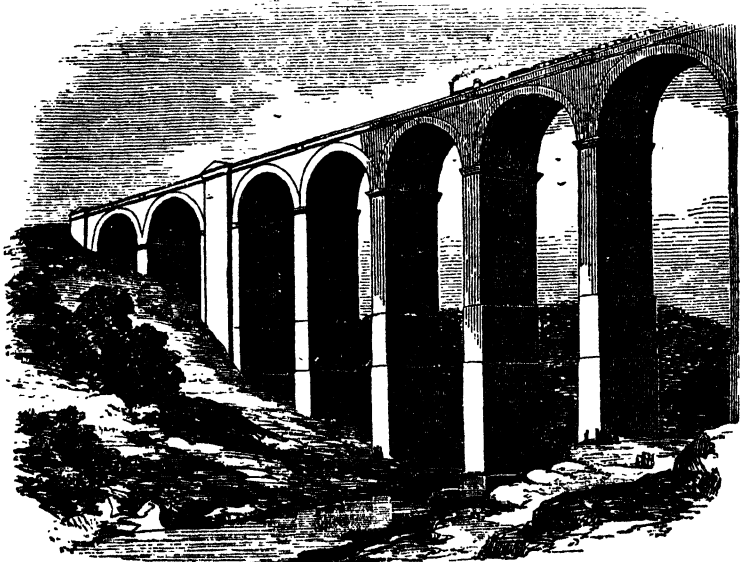
But some critics examined contemporary industrial architecture with minds unbemused by the irreality of the Classic versus Gothic controversy. There was another school of thought about design, which anticipated what we now call *functionalism*. This encouraged a volume of argumentative writing, directed to securing respect for utility for its own sake. As early as 1790, Dr. Archibald Alison had identified fitness, or the proper adaption of means to an end, as a source of the relative beauty of forms. In his *Essays on the Nature and Principles of Taste*, Dr. Alison made a conscientious analysis of such intricate subjects as "The Nature of the Emotions of Sublimity and of Beauty," and "The Sublimity and Beauty of the Material World." He brought to their examination an affection for complexity that is perhaps proper to the mind of a theologian; because Dr. Alison, who was born in 1757 and had entered Balliol College, Oxford, in 1775, ultimately became the Senior Master of the Episcopal Chapel, Canongate, Edinburgh. His *Essays on Taste* attracted much attention, and he was praised by no less a critic than Francis, Lord Jeffrey, one of the founders and the first official editor of the famous *Edinburgh Review*. Now, Dr. Alison, in his long, careful and ponderous examination of the sublimity and beauty of the material world, had come to

INDUSTRIAL ARCHITECTURE IN NINETEENTH CENTURY



The architecture of the early railways retained the link with tradition: the stations were well designed, unpretentious and perfectly fitted for the new function they had to perform. Chesterford Station, on the Eastern Counties Railway, is an example of this new railway architecture.

Below, the Congleton viaduct carries the North Staffordshire Railway 114 feet above the bed of a river. It strides across the valley on its tall arches with the established air of a Roman aqueduct. Such examples of architectural design to meet new and unprecedented industrial needs were most promising. Unfortunately, as the nineteenth century grew older taste became romantic.

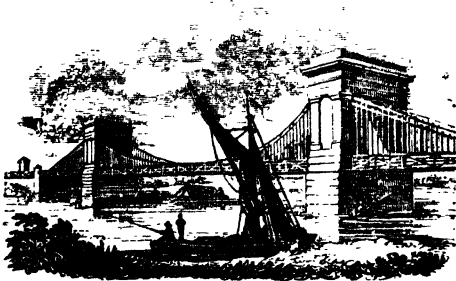


Not far from Hampton Court is

HAMPTON BRIDGE,



which, according to a modern dogma, that "utility is the basis of beauty," ought to be considered as a beautiful object. We much doubt, however, if any person can be found with sufficient enthusiasm for an abstract theory, to apply it in this instance.



This illustration and the text accompanying it represent a typical gibe at the "utility" school of thought about architectural design. They appear in *Kidd's Picturesque Pocket Companion to Richmond and its Vicinity*, published in 1833. In the same volume, approval is given to the suspension bridge at Hammersmith, completed in 1828, which represented a compromise between old and new materials. Of this the authors of the *Picturesque Pocket Companion* said: "It is the only bridge of its kind across the Thames, and there are few in any situation that can vie with it in beauty or ingenuity." Already ideas were developing that would make possible such a piece of elaborate disguise as the Tower Bridge.

the conclusion that fitness was an attribute productive of the emotion of beauty. "In the forms of furniture, of machines, and of instruments in the different arts, the greater part of their beauty arises from this consideration; nor is there any form which does not become beautiful, where it is to be found perfectly adapted to its end." After referring to a well built ship as an example of beauty attained by functional fitness, he said: "Even the most common and disregarded articles of convenience, are felt as beautiful, when we forget their

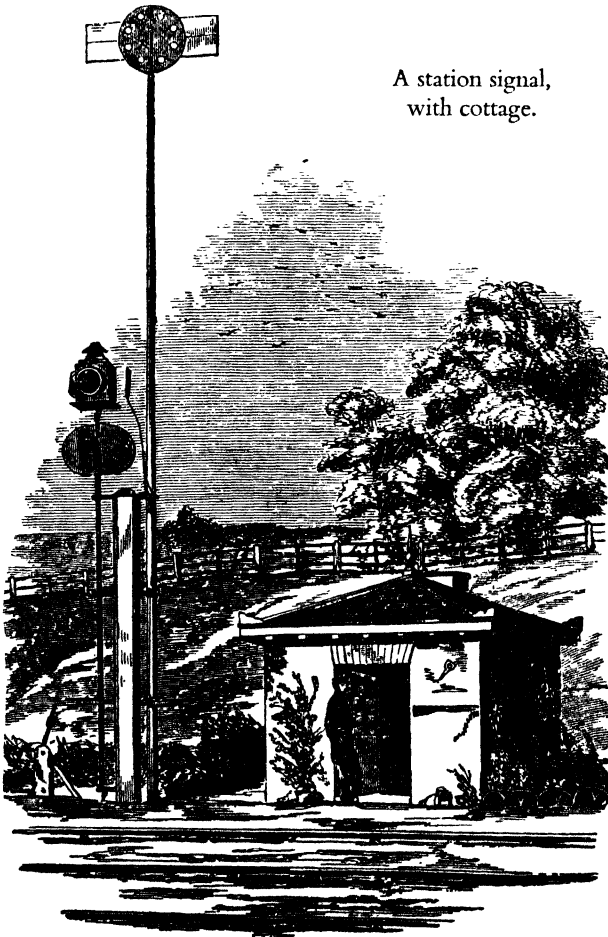
familiarity, and consider them only in relation to the purposes they serve." For seeking to apply this doctrine to the proportions of classical architecture, he was praised by Lord Jeffrey, who condensed some pages of Dr. Alison's views into the following paragraph: "There are few things about which men of virtue are more apt to rave than the merits of the Grecian architecture; and most of those who affect an uncommon purity and delicacy of taste, talk of the intrinsic beauty of its proportions as a thing not to be disputed, except by barbarian ignorance and stupidity. Mr. Alison, we think, was the first who gave a full and convincing refutation of this mysterious dogma; and, while he admits, in the most ample terms, the beauty of the objects in question, has shown, we think, in the clearest manner, that it arises entirely from the combination of the following associations: 1st, the association of utility, convenience, or fitness for the purposes of the building; 2nd, of security and stability, with a view to the nature of the materials; 3rd, of the skill and power requisite to mould such materials into forms so commodious; 4th, of magnificence, and splendour, and expense; 5th, of antiquity; and 6th, of Roman and Grecian greatness."⁸

One phrase that emerges from Lord Jeffrey's approving paragraph, *Fitness for Purpose*, has a modern ring about it, and it has gained popular currency in our time as the slogan of the Design and Industries Association, an educational body founded in 1915. But such considerations made little appeal to those responsible for architectural or industrial design in the nineteenth century. Indeed, there were many gibes at the idea that utility might be the basis of beauty; and sometimes they occurred in the most unexpected places. It seemed that nearly everybody suspected some hidden fallacy in the belief. But occasionally "fitness for purpose" was used as a basis for a critical examination of the new architecture which industry was demanding, and the strange mixture of "styles" it was using.

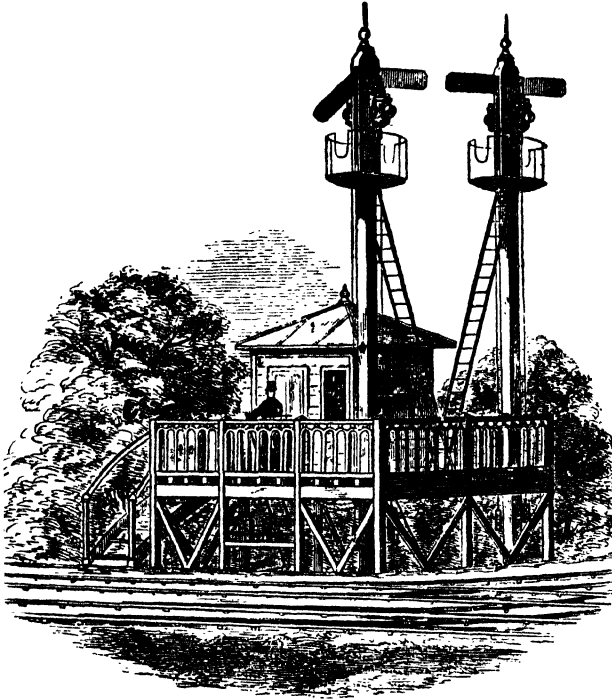
During the eighteen-fifties, there lived an observant gentleman named Samuel Sidney, who wrote improving works on economics and agriculture, such as *How to settle and succeed in Australia*; *Sidney's Emigrant's Journal*, and *Railways and Agriculture*. In 1851, he wrote a revealing and unusually interesting book entitled *Rides on Railways*.⁹ That, at least, is prominently printed on the title page of the book; the publishers, possibly recalling the popularity of Cobbett's *Rural Rides*, described it on the cover as *Railway Rides*. Ostensibly, this little work was concerned with scenery and beauty spots—for beauty was already beginning to be segregated in spots—but it dealt in some detail with railway organisation, contained many quite un-Victorian

comments on architecture, and included what amounted to an instructive history of industrial design in Manchester, to which we shall refer in the next chapter.

The power and the glory of railways appealed to Samuel Sidney. He had nothing but praise for the engineering methods that inside of twenty years had made such smooth and efficient organisations possible; but he was not pleased with the architecture of railway stations. He described Euston, then a young station, with pungent lucidity. After mentioning that the station was an after-thought, as the line was originally to have ended at Camden Town, he said: "The great gateway or propylaeum is very imposing, and rather out



A station signal,
with cottage.



Junction signals, with signalman's cabin. Structures of this type represented the real architecture of railways: regarded as utilitarian, nobody bothered to furnish them with the trimmings of a "style." They did not suffer from the attentions that created such buildings as Woburn Station, shown on page 74.

of place; but that is not the architect's fault. It cost thirty thousand pounds, and had he been permitted to carry out his original design, no doubt it would have introduced us to some classic fane in character with the lofty Titanic columns; for instance, a temple to Mercury the winged messenger and god of Mammon. But, as is very common in this country—for familiar examples see the London University, the National Gallery, and the Nelson Column—the spirit of the proprietors evaporated with the outworks; and the gateways lead to a square courtyard and a building the exterior of which may be described in the language of guide-books when referring to something which cannot be praised, as 'a plain, unpretending, stucco structure,' with a convenient wooden shed in front, barely to save passengers from getting wet in rainy weather." Of the internal planning of the station, he said that "comfort has been sacrificed to magnificence. The platform arrangements for departing and arriving trains are good, simple and comprehensive; but the waiting-rooms, refreshment stand, and *other conveniences* are as ill-contrived as possible; while a vast hall with magnificent roof and scagliola



Trains crossed over bridges that were guarded by battlements, turrets were reared above the lines, pointed arches spanned the roadway. This road bridge was built at Rugby, and below is Woburn station, on the Bedford branch of the London and Birmingham line, described by Mr. Frederick S. Williams, who illustrated it in his book, *Our Iron Roads*, in these words: "The tasteful arrangement of the building, and the contrast of the clean white walls with the oak framings, have, by the skill of the architect, combined to make it a decided ornament to a very beautiful neighbourhood." That was written in 1852 when railways were still very young, but railway architecture had already gone astray.

Already the architect, like the artist, has become separated from industrial design: all that is left is "the taste of the engineer," and that led to the treatment of the Shugborough Park Tunnel mouth on the Trent Valley Railway, on the opposite page, to the Rugby Road bridge shown above, and eventually to such things as the Tower Bridge.





Here, as the train disappears into the Shugborough Park tunnel, one can imagine the guard quoting a line from Sir Walter Scott's *Marmion*, and saying: "What, Warder, ho! Let the portcullis fall."

The author of *Our Iron Roads* discloses the hopeless confusion of contemporary ideas about design when he writes about tunnels. He says that the entrances "should be various in style, yet consistent with the style of work. They should be massive, to be suitable as approaches to works presenting the appearance of gloom, solidity, and strength. Mr. Simms, the engineer, has well remarked, that a light and highly-decorated structure, however elegant and well-adapted for other purposes, would be very unsuitable in such a situation: it is plainness combined with boldness, and massiveness without heaviness, that in a tunnel-entrance constitute elegance; and it is at the same time most economical. These conditions may be answered without cramping the taste of the engineer, as far as taste enters into the composition of such designs; for architectural display in such works would be as much misplaced as the massiveness of engineering works would be, if applied to the elegant and tastefully designed structures of the architect."

pillars, appears to have swallowed up all the money and all the light of the establishment. The first class waiting-room is dull to a fearful degree, and furnished in the dowdiest style of economy. The second class room is a dark cavern, with nothing better than a borrowed light. The refreshment counters are enclosed in a sort of circular glazed pew, open to all the draughts of a grand, cold, uncomfortable hall, into which few ladies will venture. A refreshment-room should be the ante-room to the waiting-room, and the two should be so arranged with reference to the booking-office and *cloak-rooms*, that strangers find their way without asking a dozen questions from busy porters and musing policemen. Euston station reminds us of an architect's house, where a magnificent portico and hall leads to dungeon-like dining-room, and mean drawing-room. Why are our architects so inferior to our engineers?"¹⁰

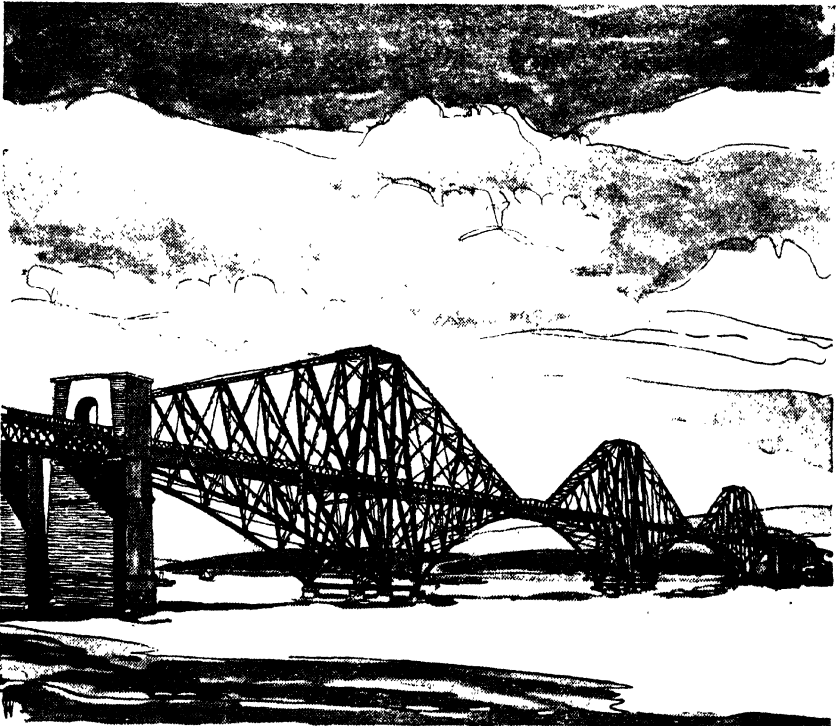
The answer to Mr. Sidney's almost agonised question was of course that engineers were the real architects and the real industrial designers of the nineteenth century. When they did their work in a straightforward fashion, when, in Lord Jeffrey's phrase, it expressed "fitness for the purposes" for which it was intended, it became the representative art of the nineteenth century, which was industrial art. But the architect and the artist had become separated from industrial architecture and design; and the engineer, who was seldom appreciative of the external appearance of his own work, often felt constrained to "apply" a little "art" to his bold and uncomplicated productions. A year after Samuel Sidney's *Railway Rides* appeared, Mr. Frederick S. Williams published *Our Iron Roads, Their History, Construction, and Social Influences*.¹¹ It contained many practical details about railway construction and operation, and discussed the design of stations and bridges, the treatment of tunnel mouths, and such incidental buildings as signal cabins, even the signals themselves—though such structures were not then classified under architecture. Indeed, architecture had by that time become almost completely separated from its basic function: like art, it was something to "apply." For example, Mr. Williams, in discussing what he called tunnel architecture, revealed why architects had become so inferior to engineers; and how even engineers, overcome by a sense of shame at the bare simplicity of their work, dabbled in architectural styles. "The entrance to tunnels should be various in style," wrote Mr. Williams, "yet consistent with the style of work. They should be massive, to be suitable as approaches to works presenting the appearance of gloom, solidity, and strength. Mr. Simms,

the engineer, has well remarked, that a light and highly-decorated structure, however elegant and well-adapted for other purposes, would be very unsuitable in such a situation : it is plainness combined with boldness, and massiveness without heaviness, that in a tunnel-entrance constitutes elegance; and it is at the same time most economical. These conditions may be answered without cramping the taste of the engineer, as far as taste enters into the composition of such designs; for architectural display in such works would be as much misplaced as the massiveness of engineering works would be, if applied to the elegant and tastefully-designed structures of the architect. The appearance of the mouths of some tunnels, especially when thrown out into prominent relief by a pleasant and well-wooded landscape stretching around and behind them, is by no means unattractive. As a proof of this statement, a better illustration could scarcely be furnished than that of the Shugborough Park Tunnel, on the Trent Valley Railway. The north face of this structure forms a noble archway, deeply moulded, flanked by two square towers, the whole being surmounted by a battlemented parapet. The lofty trees, covered with the richest foliage, rising from the elevated ground through which the tunnel is pierced, give a depth of tone and artistic effect to the whole scene at once imposing and beautiful, and form a remarkably fine feature in the scenery of the railway."¹² (See illustration on page 75.)

Unfortunately, "the taste of the engineer" led not only to the treatment of the Shugborough Park Tunnel, but to bridges that were crowned by battlements and stations that looked, or tried to look, like Elizabethan houses or mediæval castles; and eventually to structures like the Tower Bridge which H. G. Wells once likened to "a stockbroker in armour."¹³ And yet the Tower Bridge was built and opened five years before the end of the century, and its designers had before them such superb examples of industrial architecture as the Forth Bridge, which represented an unhampered expression of engineering skill. The designer of the Forth Bridge was in complete control of his materials, unbiassed by prejudices and unashamed of proclaiming the function of his work and the character of the materials he was using. Sir William Flinders Petrie, in *The Revolutions of Civilisation*,¹⁴ said that "In Mechanics, or the adaptation of long-familiar principles and materials, the full freedom of design was certainly not attained in the earlier railway work. Brunel's tubular bridge, though new, was by no means a perfect adaptation to its requirements. Perhaps Baker's Forth Bridge may be the typical example of freedom from needless restriction, in meeting one of the

oldest needs of man with methods and material already well known, apart from fresh discovery.”

The Scottish baronial trimmings of the Tower Bridge were just another example of the idea that art and architecture could be “applied.” If the Central Electricity Board had carried out its work in the latter part of the nineteenth century, and money had been sufficiently abundant, it is conceivable that as an alternative to burying the cables below ground, there might have been some scheme for disguising the steel lattice towers that carry the power lines. Art might have been “applied” to make them resemble gargantuan rustic arbours, crawling with imitation roses in enamel. Such was the taste of the nineteenth century. It takes an unconscionable time dying. As recently as 1934, at the Royal Academy banquet, the cultivated and highly educated gentleman who was then the Archbishop of Canterbury, referred to the Battersea Power



The Forth Bridge, designed by Sir Benjamin Baker: an example of late nineteenth century industrial architecture. (From a drawing by Hilton Wright.)



The Tower Bridge, completed in 1895, and unfortunately accepted all over the world as one of the structures symbolic of London. Mechanically efficient but otherwise ridiculous. (From a drawing by Hilton Wright.)

Station which, as a new and very large and conspicuously placed industrial building, had excited much attention. His Grace said that it was the one industrial building which they might have supposed would have withstood the advance of art. "Yet the genius of Sir Giles Scott had invested even it with a real nobility of art." Speaking of a projected exhibition of industrial art which was to be held at Burlington House, the Archbishop expressed the hope that if it could "inspire the masters and men of the industries to take a new interest in their workmanship, and believe that even beauty could have a marketable value, they would have some consolation for living in an industrial age."¹⁵

The attitude of mind disclosed by these views is that of the escapist who falls back on disguise to alleviate a distaste for the commercial machine age. Earlier in his speech the Archbishop referred to one alliance between art and industry and said "they had seen the ser-

vices of great artists enlisted, and the railway stations gradually converted into excellent picture galleries." Again the idea of disguise emerges. The covering of ill-designed and untidy railway stations with posters by Royal Academicians is like giving a false and transitory appearance of health by means of artificial sunburn or bronze powder to a man who is suffering from a grave organic disease for which skilful surgery is the only cure. The application of "art" can never remedy an initial absence of design. Statements such as those expressed by the Archbishop in the fourth decade of the twentieth century, merely indicate the surviving strength of Victorian taste: it was a hardy, rugged plant, thrusting out tangled branches in all directions, rooted in ignorance, emotion and romance.

During the nineteenth century, industrial architecture and design never lacked critics. Most of them were influenced by the views of John Ruskin and William Morris; some of them even approved of the murky confusion that followed the spread of industry and the penetration of cities by railways. Even Samuel Butler, who saw many things with a clarity that often made his contemporaries wince, was incapable of detecting the constant visible conflict between the architecture of the golden age of English design, and the architecture of industry. In the introductory chapter of *Alps and Sanctuaries*, published in 1881, he said: "I know of nothing in any foreign city equal to the view down Fleet Street, walking along the north side from the corner of Fetter Lane. It is often said that this has been spoiled by the London, Chatham, and Dover Railway bridge over Ludgate Hill; I think, however, the effect is more imposing now than it was before the bridge was built. Time has already softened it; it does not obtrude itself; it adds greatly to the sense of size, and makes us doubly aware of the movement of life, the colossal circulation to which London owes so much of its impressiveness. We gain more by this than we lose by the infraction of some pedant's canon about the artistically correct intersection of right lines. Vast as is the world below the bridge, there is a vaster still on high, and when trains are passing, the steam from the engine will throw the dome of St. Paul's into the clouds, and make it seem as though there was a commingling of earth and some far-off mysterious palace in dreamland."

The sense of sight, exalted by the Greeks, had become so debased in Britain by the last quarter of the nineteenth century, that an educated man like Samuel Butler with an original and critical mind could applaud the chaos he saw around him. His enthusiasm was so selective that he only mentioned the decorative steam that

INDUSTRIAL ARCHITECTURE IN NINETEENTH CENTURY



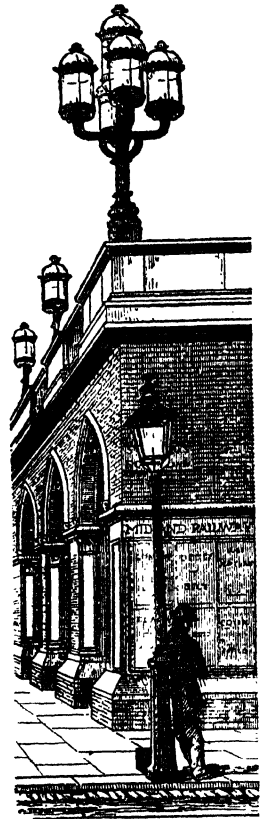
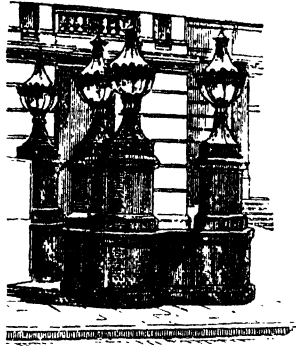
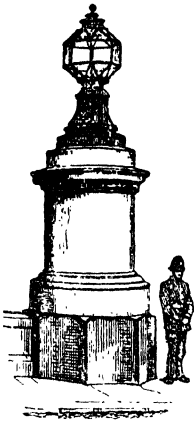
The approach to Ludgate Hill, as Doré drew it in the middle of the nineteenth century. Of this scene, Samuel Butler wrote in 1881: "I know of nothing in any foreign city equal to the view down Fleet Street, walking along the north side from the corner of Fetter Lane. It is often said that this has been spoiled by the London, Chatham and Dover Railway bridge over Ludgate Hill; I think, however, the effect is more imposing now than it was before the bridge was built."

plumed the funnels of locomotives, conveniently forgetting the smoke and the smuts they emitted and the sooty grime they deposited on buildings that flanked the railway. Butler's dislike of mechanised industry, disclosed by the pages of *Erewhon*, is nowhere apparent in the passage just quoted, for he was using his eyes and not his mind when he wrote it, and they were typically Victorian eyes. Very few nineteenth century critics enjoyed the lucid judgment of that little known writer of guide books, Mr. Samuel Sidney; but as the century aged the complacent acceptance of what passed for architectural design was occasionally attacked, though such critical adventures were usually made in pursuit of some mystical objective, such as the restoration of handicrafts or the spirit of the mediaeval guilds—never the “glory that was Greece and the grandeur that was Rome,” for Ruskin's immense influence had been used to destroy understanding of the principles that had given England its great age of good design. One fairly discerning critic, who wrote in the 'seventies and 'eighties, was an architect named John T. Emmett. Like Samuel Sidney he attacked the architecture of railway stations, selecting for the full force of his disapproval the Midland Railway terminus station, and hotel, St. Pancras. Writing in the *Quarterly Review*, in April, 1872, he said: “There is no relief or quiet in any part of the work; the eye is constantly troubled and tormented, and the mechanical patterns follow one another with such rapidity and perseverance, that the mind becomes irritated where it ought to be gratified, and goaded to criticism where it should be led calmly to approve. There is here a complete travesty of noble associations, and not the slightest care to save these forms from a sordid contact; an elaboration that might be suitable for a Chapter-house, or a Cathedral choir, is used as an ‘advertising medium’ for bagmen's bedrooms and the costly discomforts of a terminus hotel; and the architect is thus a mere expensive rival of the company's head cook in catering for the low enjoyments of the travelling crowd. To be consistent, the directors should not confine their expression of artistic feeling to their station buildings only; all their porters might be dressed as javelin men, their guards as beefeaters, and their station-masters might assume the picturesque attire of Garter-king-at-arms; their carriages might be copied from the Lord Mayor's show, and even their large locomotive wheels might imitate the Gothic window near their terminus at York. These things, however, will eventually come; the water tank is moulded in the Gothic style. Yet who is to blame for all this? In all this demonstration the directors meant, no doubt, extremely well; they were but in a state of childish and presumptuous

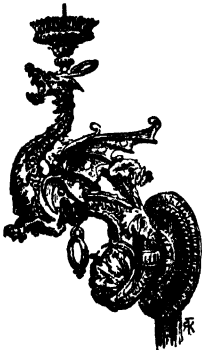
ignorance; and if the architect were held responsible, he would most probably refer to the accepted system. Of course the work is mechanical and unimaginative; but is anything superior to this required? How many of the public are there who can judge efficiently of work, or who could with discerning sympathy appreciate artistic workmen?"

He had an equally poor opinion of patrons, public and designers; and his eyes observed and condemned many of the everyday objects that most people either failed to see, or if they did, accepted without criticism, indeed without thought. In another essay, entitled "The Profession of an 'Architect,'" published in the *British Quarterly Review*, April, 1880, he described the public as "the great, unconscious enemy of art." He supported his strictures on the standards of public taste by commenting on the design of some conspicuous lamp-posts in London. "To take a very simple illustration of contemporary connoisseurship and inventive power," he wrote, "certain lamps, the thin, transparent shelter for a totally imponderable body, were required at Trafalgar Square, and mediæval workmen would have furnished metal holders, light and graceful, fitting for so light an object. This would be too rational for modern 'art'; and so we have two structures built of stone, thick as the piers of an old Norman Abbey, with a proper architectural base and moulded cornice, and two lamps superfluously solid for the Eddystone; each a burlesque construction to support a jet of gas. These monuments have stood for years by the highway, and in the centre of our 'art' metropolis, but no one has remarked on their absurdity; they seem, indeed, to be admired, for in Cannon Street, in front of the South-Eastern railway station, have been placed a dozen similar constructions, made of polished granite, to express so bright a fancy. Such absurd contrivances are the public occupation and the reason for existence of the architectural profession; the majority of modern buildings have been decorated 'tastefully' with such displays. The public see the things but cannot understand them, take them for magnificent, and so pass by; and thus by constant habit of neglect they have entirely lost the faculty of reasonable observation; sound discriminating criticism being scarcely known."

In an essay on "The Bane of English Architecture," which appeared in the *British Quarterly Review* in April, 1881, Mr. Emmett criticised another set of lamp standards. "We may however take another lamp design, from the great architectural gewgaw in the Euston Road; a bunch of five large lamps set on the high projecting corner of a balustrade. This seeming galaxy is all a sham, and wholly



John T. Emmett condemned the needless weight and clumsiness of all these lamp-posts. On the left, a lamp in Trafalgar Square; in the centre, a group of lamps at Cannon Street Station; to the right, lamps at St. Pancras Station, in the Euston Road. Of the last, he wrote: "This seeming galaxy is all a sham, and wholly useless, save as an expensive daylight show; not one of its five lamps is ever lighted."



This critic was convinced that "mediaeval workmen would have furnished metal holders, light and graceful, fitting for so light an object." And he published this illustration to explain his meaning, and labelled it "Workman's Art."

useless, save as an expensive daylight show; not one of its five lamps is ever lighted. It is placed, indeed, exactly where no light can be required, and as far towards the moon as possible. Is it not 'stupid,' quite professional, and fit to match the lamp-posts in Trafalgar Square? Yet no one has objected to it; and the hotel design throughout is just as full of unperceived absurdity."

Mr. Emmett's taste was for what he called "workmen's art," but unfortunately he published a drawing to show what he meant by that term. A writhing and complicated dragon-like object was his choice for a suitable lamp standard. Without that illustration, Mr. Emmett's apparently robust common sense might have been applauded even today; but although his critical views appear valid when expressed in words, his personal taste disclosed that he was just another victim of the romantic movement in its final phase of mediæval revivalism, when so many sincere people were attempting, as amateurs, to reinstate the arts and crafts of another and long-dead age. Such enthusiasms, generous, passionate, and unpractical, did much to confuse ideas about design, and to prevent industrial art from being recognised, enjoyed and practised in the nineteenth century by men of imagination and intelligence.

Still, nineteenth century Britain acquired some great examples of industrial architecture in which new materials were used with genius and no attempt was made to conceal their use by applying meretricious and unnecessary ornament. Outstanding were the Crystal Palace; the Forth Bridge; the great vault of St. Pancras Station—which shamed the congested and meaningless Gothic tangle of the hotel behind it—many of the bridges and viaducts of the railways and a few of the early stations. Their significance was unappreciated. If they were thought of at all, they were regarded as examples of the "utility" school of design, and therefore unconnected with architecture, art or any of those recondite matters to which cultivated people could condescend to give time and attention.

INDUSTRIAL DESIGN AND THE
MANUFACTURERS

DESIGN in industry during the nineteenth century was subjected to a variety of influences, and the results were bewildering. Very few men with trained imaginations were productively employed by manufacturers; and a hundred years ago a man who possessed our mid-twentieth century outlook on industrial planning and design would not even have been called a dangerous revolutionary; his contemporaries would not have known what he was talking about, nor would they have been able to conceive the workings of his mind. Artists and architects simply abdicated their office; and having rejected responsibility for design in industry, their place was taken by draughtsmen, men whose talent for drawing enabled them to copy patterns and ornament and to devise all manner of ingenious perversions of form, of the kind Pugin had condemned. Perhaps the most debased of such undesigned products was a miniature bronze Venus de Milo, with a clock inserted in her stomach.

That observant critic, Mr. Samuel Sidney, had much to say about industrial design as it was practised by manufacturers; and in the chapters of his *Railway Rides* he records the methods and problems of the industrialist and the not infrequent attempts made in such cities as Manchester to educate designers. But the pursuit of "novelty" in ornament—for the word *design* was generally taken to mean *ornament* when Samuel Sidney was writing—and the hot pace of competition, led from one complexity to another in the shape of nearly everything that people took into their homes or used in their places of business. For example, Mr. Sidney unearthed a queer passion for "novelty" in Birmingham, where he found that undertakers were the most active and exacting patrons of an obscure branch of industrial art, namely the manufacture of coffin ornaments.

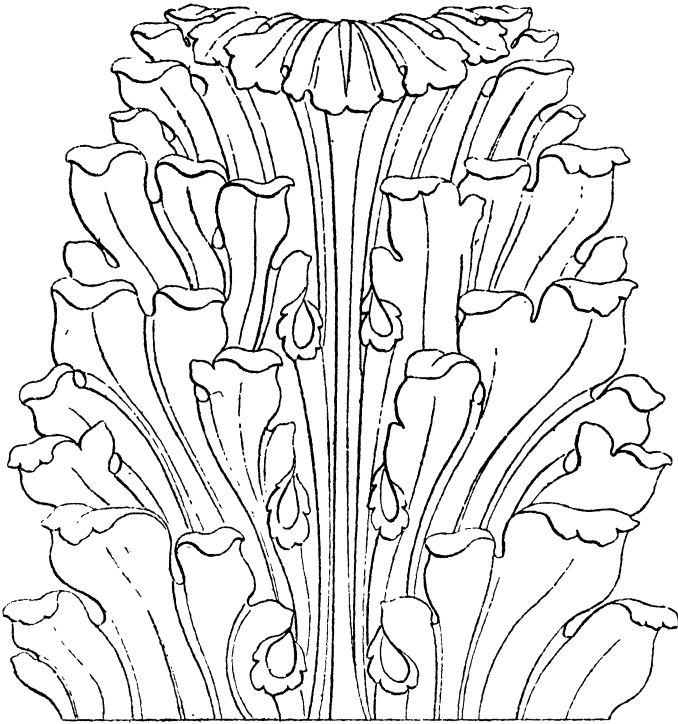
"Who is it that examines and compares the ornaments of one coffin with that of another?" asked Mr. Sidney. "We never heard of the survivors of a deceased examining an undertaker's patterns. And yet, a house which consumes forty tons of cast iron per annum

for coffin handles, stated to the gentleman to whose letters we are indebted for this information, 'Our travellers find it useless to show themselves with their pattern books at an undertaker's, unless they have something tasteful, new and uncommon. The orders for Ireland are chiefly for gilt furniture for coffins. The Scotch also are fond of gilt, and so are the people in the west of England. But the taste of the English is decidedly for black. The Welsh like a mixture of black and white. Coffin lace is formed of very light stamped metal, and is made of almost as many patterns as the ribbons of Coventry. *All our designs are registered, as there is a constant piracy going on which it is necessary to check.*' "

When he visited Manchester he described the early and sincere struggles of that manufacturing centre to improve industrial art. In the Mechanics' Institute at Manchester, which was founded in 1824, there was a department of design. "This School of Design," wrote Mr. Sidney, "supported by the Government for the purpose of promoting design as applied to the staple manufactures, and diffusing a general feeling for art amongst the manufacturing community, was formerly accommodated within the walls of the Royal Institution as a tenant, paying a rent, strangely enough, for the use of a building which had ostensibly been erected for promoting art and science! It was not until 1836, that, on the recommendation of a Committee of the House of Commons, active steps were taken to establish in England that class of artistic instruction applied to manufactures which had been cultivated in France ever since the time that the great Colbert was the minister of Louis XIV."

And here we may interpolate that brief analysis of Colbert's motives, which R. H. Wilenski makes in *A Miniature History of European Art*.¹ "His aim was to acquire for the French the reputation of the finest artist-craftsmen in Europe, because he knew that such a reputation would be a great cash asset to the State. He succeeded; the reputation and the revenue persist to this day."

Mr. Sidney continued: "At Manchester some of the leading men connected with the calico-printing trade and looms of art, established a School of Design within the Royal Institution, where two rooms were lent rent-free; but, as soon as Government apportioned a part of a special grant to the Manchester School, the Committee, who were also as nearly as possible the Council of the Royal Institution, with that appetite for public money which seems incident to men of all nations, all classes, and all politics, voted £100 out of the £250 per annum for rent. This school did nothing of a practical nature, and consequently did not progress in public estimation. The



Here is an early nineteenth-century portrait of the acanthus leaf in its conventionalised form. Innocent enough in appearance, it became for manufacturers and their designers (who were seldom more than skilled draughtsmen) an abominable tyrant in the early industrial period. This illustration is taken from the 1836 edition of George Smith's *Cabinet Maker and Upholsterer's Guide*, originally issued ten years earlier, and described by its author as "a complete drawing book."

Such conventional ornaments retained some individuality when they were carved in stone or wood, or shaped in wrought iron; and although repetition was the avowed aim of all such ornaments, and of the classic orders themselves with their rows of identical columns, the personal skill of the carver or smith gave vitality to the forms an architect, or a fashionable furniture maker or interior decorator, had ordained. But when industrial technique conferred enormous powers of repetition on manufacturers and designers, the results were monotonous. Mass-production acquired a bad name and "machine-made" became almost a term of abuse, because industry's great powers of repetition were used to cast or press out ornament in metal or composition. Very few people designed for "machine production." Everybody was haunted by prototypes, even in the new forms of transport that were beginning to quicken the pace of life in the early nineteenth century. The industrial revolution got into its stride without the significance of industrial design becoming recognised: a man who could draw patterns and ornament was good enough for the manufacturer; as for the artist—industry frightened him, and he abdicated his responsibility for understanding and influencing contemporary life.

master was a clever artist, but not up, perhaps he would have said not *down*, to his work. A School of Design at Manchester is meant, not to breed artists in high art, but to have art applied to the trades of the city. The master was changed, and, at the request of the local committee, the Council of the School of Design at Somerset House sent down, in 1845, Mr. George Wallis, who had shown his qualifications as an assistant at Somerset House and as master of the Spitalfields school. At that time the Manchester School had been in existence five years, and had done nothing towards its original object. In two years from the time of Mr. Wallis taking the charge, the funds of the school were flourishing; the interest taken in it by the public was great, and nearly half the Institution was occupied by the pupils, while the applications for admission were more numerous than could be accommodated. Under this management the public, who care little for abstract art, were taught the close connection between the instruction of the School of Design and their private pursuits.

"*This* is what is wanted in all our towns. It is not enough to teach boys and girls—the manufacturers and purchasers need to be taught by the eye, if not by the hand. According to part of Mr. Wallis's plan, an exhibition was held of the drawings executed by the pupils for the annual prizes, which had a great influence in laying the foundation for the efforts made by Manchester at the Great Exhibition of Industry in Hyde Park.

"While matters were proceeding so satisfactorily, the Somerset House authorities (who have since been tried and condemned by a Committee of the House of Commons), proceeded to earn their salaries by giving instructions which could not be carried out without destroying all the good that had been done. The Manchester Committee and Mr. Wallis protested against this *red tapish* interference. It was persisted in; Mr. Wallis resigned, to the great regret of his pupils and manufacturing friends in the managing council." (Mr. Sidney mentions in a footnote that at the Great Exhibition of 1851, Mr. G. Wallis, at the suggestion of the Board of Trade, had the management and arrangement of the department of manufactures.)

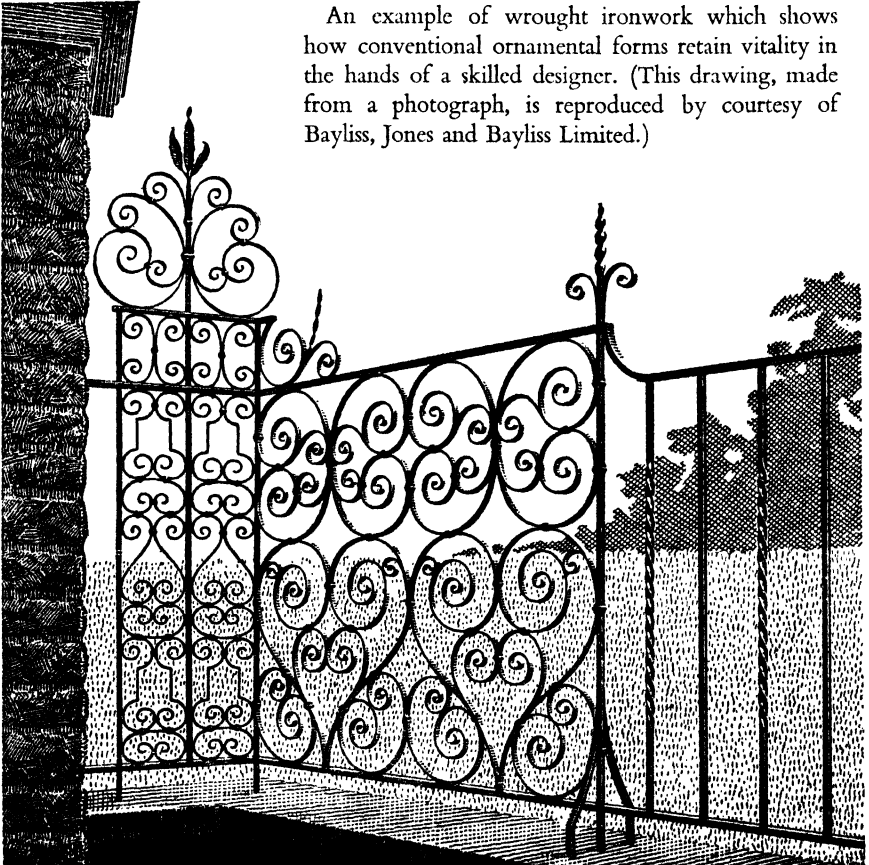
"The result was that the undertaking dwindled away rapidly to less than its original insignificance—the students fell off, and a deficit of debt replaced the previously flourishing funds. Out of evil comes good. The case of Manchester enabled Mr. Milner Gibson, M.P. for Manchester, to get his Committee and overhaul the Schools of Design throughout the kingdom.

"Certain changes were effected. The school, no longer able to pay

the high rent required by the Royal Institution, was removed to its present site in Brown Street, placed under the management of Mr. Hammersley, who had previously been a successful teacher at Nottingham, and freed from the meddling of incompetent authorities. And now pupils anxiously crowd to receive instruction, and annually display practical evidence of the advantages they are enjoying."

Clearly Mr. Sidney was satisfied about the health of the School of Design; and we may perhaps attribute its failure to have any permanent influence to the fact that manufacturers seldom recognised the importance of introducing fresh talent from creative designers, and were content with the mediocre output of docile hacks with a talent for "drawing." This critic had no illusions about the

An example of wrought ironwork which shows how conventional ornamental forms retain vitality in the hands of a skilled designer. (This drawing, made from a photograph, is reproduced by courtesy of Bayliss, Jones and Bayliss Limited.)

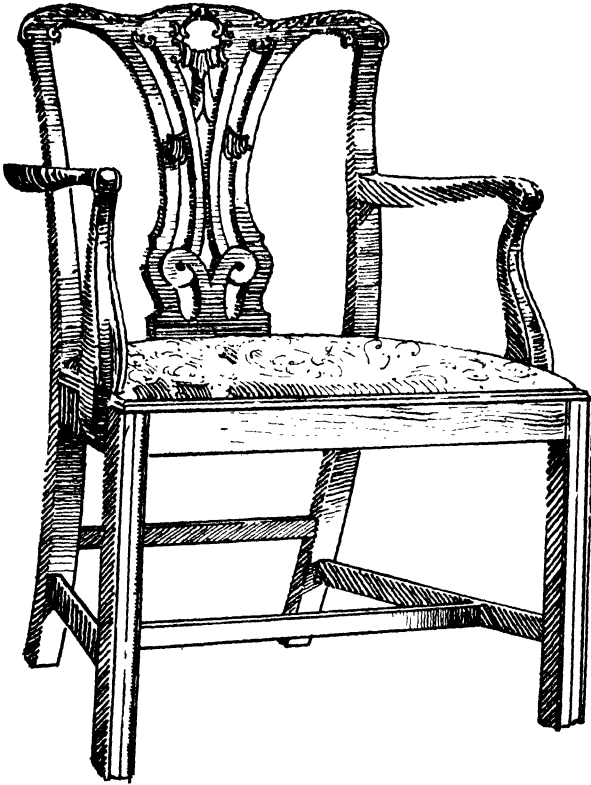


discouraging environment provided by manufacturing towns. Of Leeds he wrote: "The public buildings are not externally imposing, and it is, without exception, one of the most disagreeable-looking towns in England—worse than Manchester; it has the reputation of being very unhealthy to certain constitutions from the prevalence of dyeworks."

Contrast this description with his view of an industry that began in the eighteenth century. "We may observe, that there is no more pleasant mode of investigating the processes of the woollen manufacture, for those resident in the south of England, than a visit to the beautiful valley of the Stroud, in Gloucestershire, where the finest cloths, and certain shawls and fancy goods, are manufactured in perfection in the midst of the loveliest scenery. White-walled factories, with their resounding water-wheels, stand not unpicturesque among green wooded gorges, by the side of flowing streams, affording comfortable well-paid employment to some thousand working hands of men and women, boys and girls."

He condemned the careless growth of manufacturing towns. "Birkenhead," he said, "is a great town, which has risen as rapidly as an American city, and with the same fits and starts. Magical prosperity is succeeded by a general insolvency among builders and land speculators; after a few years of fallow another start takes place, and so on—speculation follows speculation. Birkenhead has had about four of these high tides of prosperous speculations, in which *millions* sterling have been gained and lost. At each ebb a certain number of the George Hudsons of the place are swamped, but the town always gains a square, a street, a park, a church, a market-place, a bit of railway or a bit of a dock. The fortunes of the men perish, but the town lives and thrives. Thus piece by piece the raw materials of a large thriving community are provided, and now Birkenhead is as well furnished with means for accommodating a large population as any place in England and has been laid out on so good a plan that it will be one of the healthiest as well as one of the neatest modern towns."

From this contemporary observer's account we perceive the complicated development of industrialism, its combination of efficiency and muddle, its well-organised railways, its disorganised factory growth, and the incoherent profusion of its productions. The great ability of the English craftsman had provided up to the end of the Georgian period a fine character for things of everyday use. The comeliness of commonplace objects was destroyed by mechanical production. The educated direction which all design had received



A mid-eighteenth-century elbow chair, which illustrates the use of classical ornament. The acanthus leaf is used with restraint to embellish the back. (Reproduced by courtesy of Heal and Son Ltd. from a drawing.)

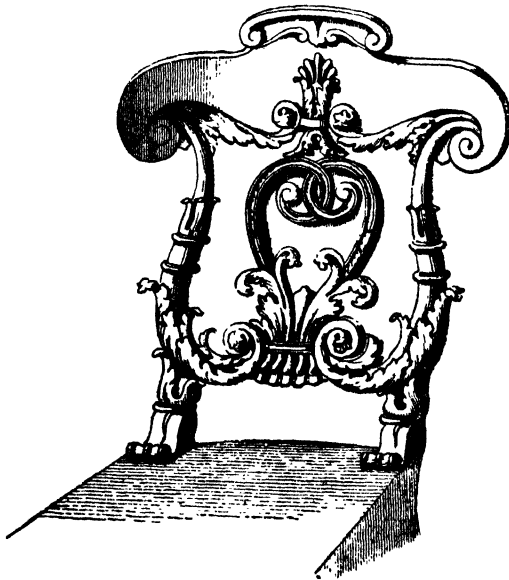
from architects was interrupted, and the secondary place to which architects had sunk in the estimation of such clear-sighted critics as Mr. Sidney is suggested by his question, quoted in the last chapter: "Why are our architects so inferior to our engineers?" The engineer had become the dominant figure of the century, and he was the principal technician recognised by the manufacturer. The designer had disappeared from society. He had hardly ever appeared in the factory. The sporadic efforts to train designers mentioned by Mr. Sidney and those described in the historical section of the report made by the Gorell Committee (which was appointed in July, 1931)² do not suggest that the designer was ever regarded as a technician. He was at best a pattern-maker, a docile draughtsman who could devise on his drawing-board an infinity of variations

INDUSTRIAL DESIGN AND THE MANUFACTURERS

upon such a theme as, say, coffin ornaments. Machinery could cast or stamp ornament by the mile. Only drawings were needed to set the machine to work; and this confusion of draughtsmanship with design still obscures the comprehension of many manufacturers. It is not widely understood that design is not a mere trick of the pencil, and that it is produced only by trained imagination. To refer to a studio full of draughtsmen ringing the changes on patterns as a "design department" is a mistake that has been and is still being made all over industrial Britain.

Because of the absence of designers in the nineteenth century, and because of the facilities for imitation offered by the machine there was a long period of limp adaptation of shapes and patterns originally evolved by hand. These shapes and patterns were "applied" to machine-made things.

There were a few examples of collaboration between manufacturers and designers, and Sir Matthew Digby Wyatt, Slade Professor of Fine Art, in a series of lectures delivered at Cambridge in 1870 discussed the ancient and modern relationship of art and industry.³



The use of ornament became debased in the nineteenth century. What might be described as the curse of the acanthus afflicted designers. Compare this chair back with the eighteenth century elbow chair opposite. (From George Smith's *Cabinet Maker and Upholsterer's Guide*.)

In referring to Wedgwood he said: "It was his delight to work hand in hand with the best artists, and (far in advance of his time) he recognised the commercial value of design as an assistant to Industry. He clearly saw that public interest would be excited by excellence, that cultivation was necessary for the development of taste, and that artists could only properly design for manufacturers, who identified themselves with the operations and specialities of the branches of industry in connection with which they exercised their art.

"Herbert Minton, no less than Wedgwood, spent a long and laborious life in raising the character of the branch of manufacture to which he devoted himself."

The Royal Society of Arts, founded in 1754, played a leading part in the stimulation of design in industry during the nineteenth century. Before the Great Exhibition of 1851, the Society had been active in promoting small-scale exhibitions, and had encouraged experiments in design by awards, which took the form of medals and special prizes. Between 1846 and 1850 recipients of the Society's medals included Minton & Co., and Copeland (pottery); Osler & Co., and Pellat & Co. (glass); and various other firms whose products included iron castings, carpets, jewellery and safes.⁴ In his notes on Birmingham, Mr. Samuel Sidney refers to the glass made by "Messrs. F. & C. Oslers, of Broad Street" and states that the firm has "attained a very high reputation for their cut and ornamental, as well as the ordinary, articles of flint glass. They have been especially successful in producing fine effects from prismatic arrangements. Their gigantic chandeliers of great size, made for Ibrahim Pacha, and the Nepaulese Prince, were the steps by which they achieved the lofty crystal fountain, of an entirely original design, which forms one of the most novel and effective ornaments of the Crystal Palace." He adds: "The manufactory as well as the showroom is open to the inspection of respectable strangers."⁵

The factories of Birmingham and other industrial centres did not lack inventive brains; but much inventive power was given to "putting on" a little or a lot of "art"; and this idea of clothing manufactured articles with "applied art" debauched the whole conception of design, so at last the word stood for choosing the sort of "art" you wanted to "apply." Mr. Sidney's remarks upon Mr. Winfield of Birmingham illustrate the results of this approach to design.

"Mr. Winfield is one of the manufacturers in brass whose showrooms are open to the public. He also has claims on our attention for the wise and philanthropic manner in which he has endeavoured

to supply the lamentable deficiency of education among the working classes. He holds a very leading position as a manufacturer of balustrades, tables, window-cornices, candelabra, chandeliers, brackets, curtain-bands, and above all of metal bedsteads, which last he has supplied to some of the chief royal and princely families of Europe, besides Spain, Algeria and the United States. In all these works great attention has been paid to design as well as workmanship, as was amply proved both at the local exhibition in 1849, where a large gas bracket, in the Italian style, of brass, with Parisian ornaments, excited much admiration; and in 1851, in Hyde Park, where we especially noted an ormolu cradle and French bedstead in gilt and bronze, amid a number of capital works of his production.”⁶

Still dealing with Birmingham, Mr. Sidney notes that “Messrs. Messengers & Sons have one of the finest manufactories in ornamental iron, brass, and bronze, for lamps, chandeliers, and table ornaments. For a long series of years they have spared no expense in obtaining the best models and educating their workmen in drawing and modelling. In their show rooms will be found many very pleasing statues in gold-colour, in bronze, and copies from antique types of vases, lamps, candelabra, etc.”

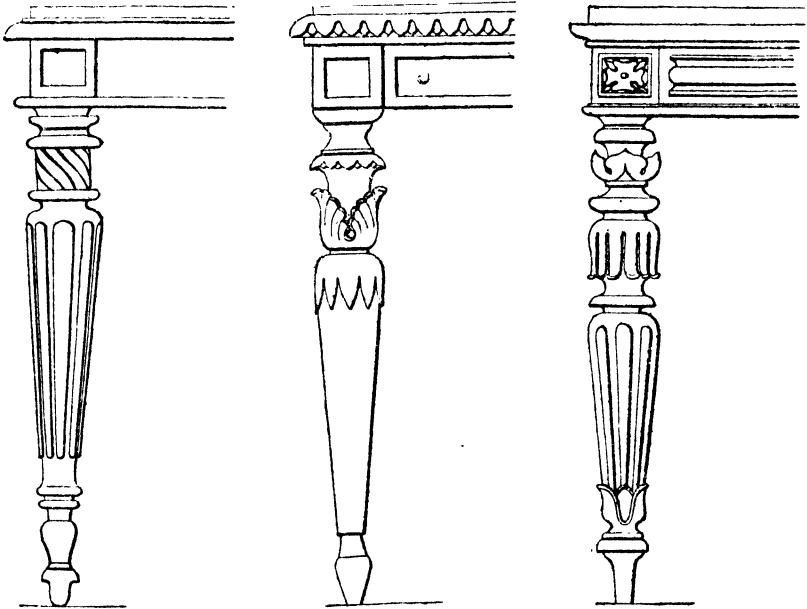
What did that education of workmen “in drawing and modelling” imply? Did it train and activate any innate imaginative gifts? Did it give them understanding of proportion; did it sharpen their critical judgment of form? Or did it just give them a knack of copying “antique types,” and develop their powers of adapting the character of such types to the needs of mechanical production? The illustrated records of the Great Exhibition of 1851 and the catalogues of firms who were manufacturing products that were supposed to be influenced by “art,” show that by the middle of the nineteenth century the word design as we understand it and as the eighteenth century understood it, had lost its meaning. But the contents of the Great Exhibition only delighted and stimulated contemporary observers: nobody saw anything amiss with the exhibits, and everybody was heartened by the stupendous proof they afforded of the mechanical and scientific progress of the age. In a lecture delivered before the Society of Arts, on November 26, 1851, Dr. William Whewell, F.R.S., Master of Trinity College, Cambridge, took as his subject “The General Bearing of The Great Exhibition on the Progress of Art and Science.”⁷ After commenting on the comparative excellence of the exhibits of the East Indies, Dr. Whewell said: “Even we, while we look down from our lofty summit of civilised and mechanically-

aided skill upon the infancy of art, may often learn from them lessons of taste." He was a little troubled by that excellence in "the works of nations long civilised, though inferior to ourselves, it may be, in progressive civilisation and mechanical power"; and he put a few questions which must have momentarily alarmed his audience. "What, then, shall we say of ourselves?" he asked. "Wherein is our superiority? In what do we see the effect, the realisation, of that more advanced stage of art which we conceive ourselves to have attained? What advantage do we derive from the immense accumulated resources of skill and capital—of mechanical ingenuity and mechanical power—which we possess?" He reassured his hearers and himself by dwelling upon the vast scale of mechanical production, and its objectives, saying: "and thus such machinery is applied when wares are manufactured for a vast population; when millions upon millions have to be clothed, or fed, or ornamented, or pleased, with the things so produced." The design of the goods that flowed out from thousands of factories to millions of consumers was ignored by this commentator; but presumably those consumers were duly "ornamented" and "pleased" by the undesigned products of mechanised industry.

Even the persistent work of the Society of Arts, as it was then called—for it was in 1908 that permission to add the word "Royal" to its title was granted by King Edward VII—the awards made by that body for the encouragement of "art" in industry and the exhibitions it sponsored, could not reinstate design, nor educate the manufacturer about the character of the designer. The Society then, as now, was devoted to the promotion of arts, manufactures and commerce, and its activities ranged from the introduction of medicinal plants to Great Britain to the humanitarian encouragement of inventors to produce mechanical devices which would replace child labour in chimney-sweeping.⁸ As early as 1828 an attempt was made to hold a national exhibition of industrial products. George IV encouraged the exhibition committee with his patronage, and it was proposed to hold annual exhibitions "of new and improved productions of our artisans and manufacturers."⁹ The scheme failed to secure adequate support from industry. There were other attempts to organise industrial exhibitions, one in Birmingham in 1836; and in 1844 and 1845, small exhibitions were held in the rooms of the Society of Arts. Though limited in scope and duration (they only lasted for one evening) they began the movement which led to the 1851 Exhibition.¹⁰

The Prince Consort was elected President of the Society in 1843,

and he took a new and energetic view of its responsibilities. He insisted that its function was to "improve the condition of the artistic industries of the country" and "had urged on the Society, as its proper work, the encouragement of the application of art to practical purposes."¹¹ The lost meaning of design is revealed by that choice of words: *the application of art to practical purposes*. Prizes might be



The sense of proportion departed. These three table legs show another stage in the decay of understanding and care for good proportion. (From George Smith's *Cabinet Maker and Upholsterer's Guide*.)

offered for artistic designs; all they produced were applications and variations of ornament, culled from antique sources, by draughtsmen.

This mounting confusion which fostered the most repulsive ornamental congestion was accompanied by a splendour of technical achievement in industry. Even Mr. Sidney became almost lyrical about the industrial capacity of Birmingham and the character of its inhabitants. He wrote: "Birmingham is, in fact, notable for its utility more than its beauty—for what is done in its workshops, rather than for what is to be seen in its streets and suburbs. Nowhere are there to be found so numerous a body of intelligent, ingenious,

well-educated workmen. The changes of fashion and the discoveries of science always find Birmingham prepared to march in the van, and skilfully execute the work needed in iron, in brass, in gold and silver, in all the mixed metals and in glass. When guns are no longer required at the rate of a gun a minute, Birmingham steel pens become famous all over the world. When steel buckles and gilt buttons have had their day, Britannia teapots and brass bedsteads still hold their own. No sooner is electrotype invented, than the principal seat of the manufacture is established at Birmingham. No sooner are the glass duties repealed than the same industrious town becomes renowned for plate glass, cut glass, and stained glass; and, when England demands a Palace to hold the united contributions of 'The Industry of the World,' a Birmingham banker finds the contractor and the credit, and Birmingham manufacturers find the iron, the glass, and the skill needful for the most rapid and gigantic piece of building ever executed in one year."¹²

While technical ability increased and the design of machinery improved, the idea of "applied art" stifled the development of industrial art. Its healthy evolution was delayed for generations by one of the consequences of the romantic movement, which took the form of an attempt to revive handicrafts under the leadership of William Morris. The ramifications of this movement and the harm it did to industrial art by delaying the period when it could be clearly identified, practised and directed, form the subject of a later chapter. The fact that we have never had the leadership in industrial design which the United States has attained, may be attributed partly to the retarding influence of the teachings of William Morris. If he had not been a highly skilled creative craftsman, he might have been dismissed by posterity as a rich man indulging a hobby and confusing an issue—a mere parlour socialist who disliked commerce. His personal creative work was of a high order, and its educative effect was considerable, despite its reactionary character. But even Morris had to admit the mechanical achievements of his own century; he disliked them; he made no attempt to understand or use them; he felt no sense of responsibility for their direction; but he conceded their power and sometimes speculated upon their possibilities. A little wistfully, in a lecture on "Art and Socialism," he said: "Those almost miraculous machines, which if orderly forethought had dealt with them might even now be speedily extinguishing all irksome and unintelligent labour, leaving us free to raise the standard of skill of hand and energy of mind in our workmen, and to produce afresh that loveliness and order which only

the hand of man guided by his own soul can produce—what have they done for us now?”

There was nothing in the so-called “art products” of the mid-nineteenth century that could provide a reassuring answer to a question like that. Only in the work of engineers, concerned with machine design, was there any approach to freedom from borrowed characteristics.

INDUSTRIAL DESIGN AND THE ENGINEERS

DURING the nineteenth century the growth of scientific knowledge, and the application of that knowledge to industry, international trade, transport and everyday life, established a confident faith in the inevitability of progress. In material conveniences there was not much difference between life in the opening decades of the nineteenth century and life in the Roman Empire under Augustus: it was still the horse and cart age, though vehicle design had improved and at sea sailing ships had attained dimensions and standards of performance far beyond anything the ancient world could show. But the difference between conditions of life in the last few years of George III's reign and those of mid-Victorian times was stupendous: science, it seemed, was lifting mankind above all the old, cramping, accepted limitations of space and time, and everywhere machines were creating and unevenly distributing new wealth, though this uneven distribution never made the social structure top-heavy, like the Cambodian Empire or other oriental tyrannies. The machines and mechanical processes that were invented and employed in the nineteenth century, could not be used exclusively for a small privileged class. The railways had to provide for second and third class as well as first class passengers; industrial development demanded the widest possible market, and a great share-out of goods to all sections of society followed. The machine could serve a democracy well; for an aristocracy it could provide only a limited service. Some time elapsed before this characteristic of machinery and industrial production was apprehended; and recognition of it was generally flavoured with mild astonishment. Dr. Whewell in his lecture on the progress of art and science in relation to the Great Exhibition, had dwelt upon this essential difference between an aristocracy that commanded all the available skill of a country for its own luxurious enjoyment and an industrial democracy where skill was organised and widely shared. His surprise was perceptible; but he was pleasantly, not resentfully, surprised when he spoke thus to his audience at the Society of Arts: "I have heard one say, who had

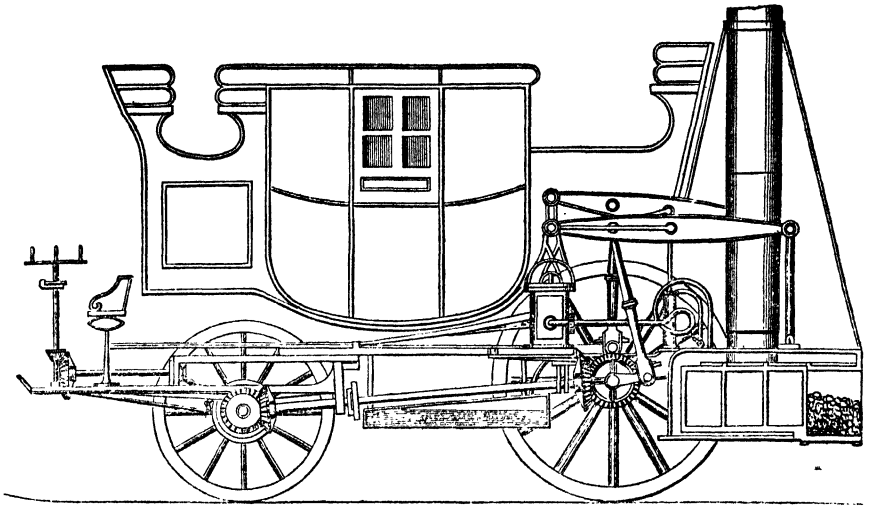
extensively and carefully studied the manufacturing establishments of this country, that when he began his survey he expected to find the most subtle and refined machinery applied to the most delicate and beautiful kind of work—to gold and silver, jewels and embroidery: but that when he came to examine, he found that these works were mainly executed by hand, and that the most exquisite and the most expensive machinery was brought into play where operations on the most common materials were to be performed, because these were to be executed on the widest scale. And this is when coarse and ordinary wares are manufactured for the many. This, therefore, is the meaning of the vast and astonishing prevalence of machine-work in this country: that the machine with its million fingers works for millions of purchasers, while in remote countries, where magnificence and savagery stand side by side, tens of thousands work for one. There Art labours for the rich alone; here she works for the poor no less. There the multitude produce only to give splendour and grace to the despot or the warrior whose slaves they are, and whom they enrich; here the man who is powerful in the weapons of peace, capital and machinery, uses them to give comfort and enjoyment to the public, whose servant he is, and thus becomes rich while he enriches others with his goods. If this be truly the relation between the condition of the arts of life in this country and in those others, may we not with reason and with gratitude say that we have, indeed, reached a point beyond theirs in the social progress of nations?"

There were so many powerful stimulants for the imagination in the possibilities of applied science, that art became incidental in the great march of progress. Europe in the nineteenth century was undergoing one of those great intellectual and moral upheavals that revolutionise life and thought for hundreds of years; and it made our island turbulent with enterprise. In his book *Victorian England*, Mr. G. M. Young has reminded us "that the Victorian age is only the island counterpart of a secular movement, as significant as the turn from the Greek middle ages in the time of Socrates or the Latin middle ages at the Renaissance. Twice the European mind had been carried to the verge, and twice it had been baffled. In the nineteenth century it won the top and saw stretching towards it that endless new world which Bacon had sighted, or imagined, where nothing need remain unknown, and for everything that is known there is something that can be done; the world of organised thought where even modern scientific man was only the rudiments of what man might be."¹

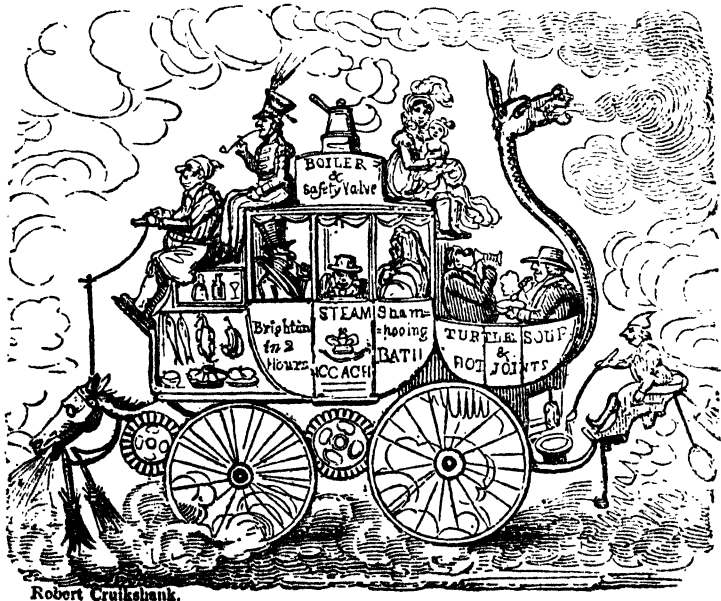


Between 1750 and 1830 the stage coaches and the roads of Britain were improved in design and construction; speed was increased, and even comfort; highwaymen found it increasingly difficult to make a living; and the great days of coaching arrived. It was an exhilarating period, hustling and happy. It is preserved in *Pickwick*, in the description of the journey to Rugby in *Tom Brown's Schooldays*, and in the pictorial folklore that still influences the character of our Christmas cards. In Chapter IV of *Travel in England*, Thomas Burke points out that "The sense of speed affected the coachowners in naming their coaches. They were no longer Machines or Regulators. They were named Highflyers, Quicksilvers, Comets, Rockets, Greyhounds, Lightnings, Expresses, Hironnelles."

The stage coach became a national institution; it held the affection and admiration of townsmen and countrymen alike, of passengers and people who never travelled. When in the beginning of the railway age, steam coaches were designed for use on the roads, they failed; but their failure was not wholly mechanical. Some of them were successfully operated for a short time; but they never captured the imagination of the public; they never overcame the immense reserves of hostility that Englishmen can command for the crushing of original ideas. Unlike the "Iron Horse," which demanded special roads of its own and did not interfere with existing traffic, the steam road coach was an unwelcome innovation. In design, most of these experimental coaches were singularly unenterprising: a normal coach body was superimposed on a rather complicated frame which carried the mechanism. The coach and frame were considered as separate parts; their union was haphazard and untidy. It was impossible to forget the absence of the horse, and equally impossible to forgive the presence of the puffing engine.



The design for a steam coach by Burstall and Hill, shown above, was an unhappy hybrid which invited caricature. The drawing below by Robert Cruikshank represented the popular response. The eighteenth twenties was many such experiments; but competition with horse traffic saw difficult on its own ground. The date of the Burstall and Hill coach is 1824. A year earlier a long account of a steam carriage, patented by Julius Griffith, appeared in *The Mirror*. An illustrated extract from this publication is given on the next page.



Robert Cruikshank.

The Mirror

OF

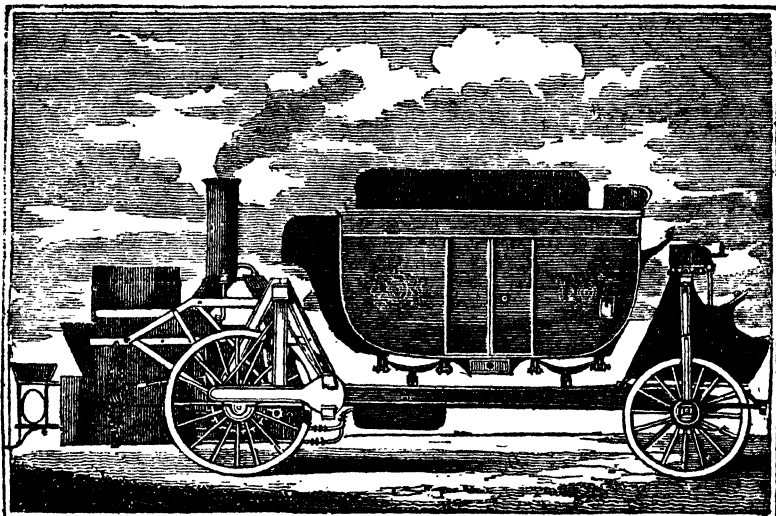
LITERATURE, AMUSEMENT, AND INSTRUCTION.

No. XVI.]

SATURDAY, FEBRUARY 16, 1828.

[PRICE 2d.]

Patent Steam Carriage.



Our engraving this week presents a singular instance of the application of mechanical power—in fact, one of its proudest triumphs—the construction of a machine adapted to the transport of goods, without the necessity of animal labour. This is a carriage (for which Julius Griffith, Esq. of Brompton-Crescent, has obtained a patent) to be propelled by steam upon common roads. The carriage, which has been constructed under the eye of Mr. Griffith, assisted by Mr. F. Bramah, at Pinlico, is twenty-seven feet in length, including seven feet for the fire, boiler, cylinders, and the mechanism connected with the driving-wheels.

Instead of an axle-tree passing through both the front or both the hind wheels, as is usual in other carriages, the axis merely passes through the nave of each wheel sufficiently to support on each side uprights, which strengthen and connect the frame of the waggon. From the hind part of this frame, or bed, proceed two perches, inclining inwards until they meet: and, being joined a few feet before they reach the front wheels, they

Vol. I.

form the bed of a revolving perch; this revolving perch is connected with the bed of the fore part of the carriage, or front wheels, and by its rotatory motion, when either of the wheels is more elevated or depressed than the other, preserves the horizontal position of the carriage.

The direction of the carriage is effected by the action of a bevel pinion, connected with a spindle, which is governed by the coachman; this pinion acts on a wheel, whose movements compel those of certain iron braces fixed to the exterior of the front wheels, which turn upon the same spot where they touch the ground; so much power is gained by this pinion, that little force is required from the coachman to produce the necessary direction.

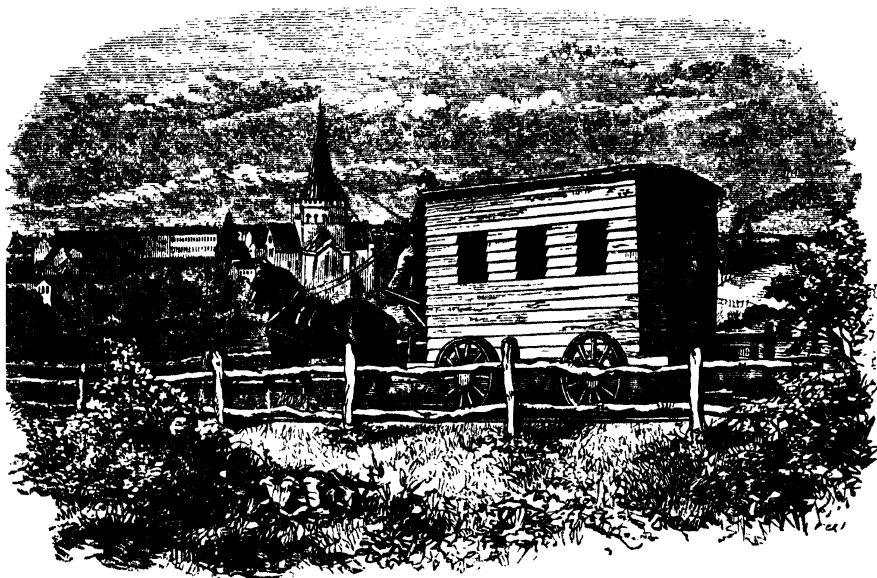
In addition to every other kind of security that the most profound reflection has enabled Mr. Griffith to adopt, there are two safety-valves calculated at fifty pounds upon a square inch, whilst every part of the steam apparatus has been proved at the rate of 200 pounds upon a square inch.

R

See page 103, and opposite page.

Mr. Griffith confidently anticipated the cheapening of road transport for goods. His steam carriage was calculated to weigh $1\frac{1}{2}$ tons, and it was designed to carry 3 tons of merchandise. The account in *The Mirror* which is partly reproduced on the opposite page, is concluded by the following tribute to the inventor: "Actuated by a disposition to promote the public welfare, it is Mr. Griffith's intention to reduce the prices now paid for the carriage of goods throughout the country; and, should it be proved that Mr. Griffith's steam carriages can convey goods in an equally secure manner with other waggons, at the rate of five miles per hour, or 100 miles per day of twenty travelling hours; and, at a freight, 25 per cent cheaper than the present prices, there can be no question that he will have deserved well of his country and of mankind."

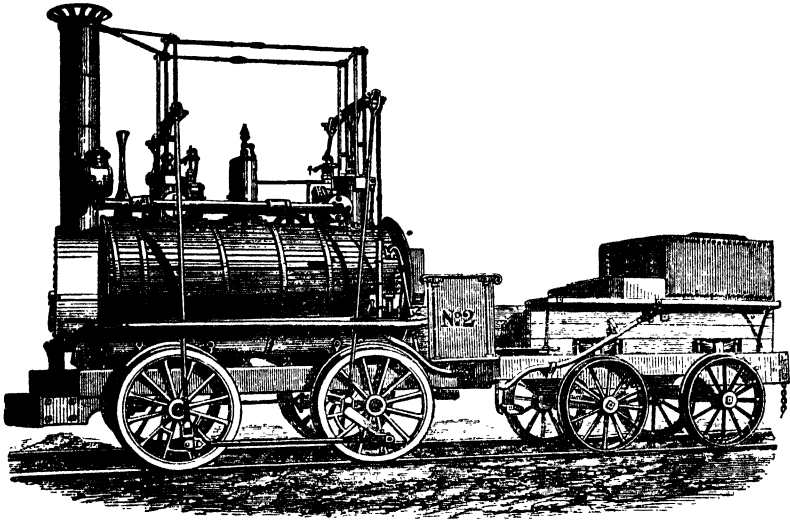
It was perhaps only natural for the designers of steam road coaches to retain the lines of the horse-drawn vehicle; but when railways began to carry passengers, designers were still thinking in terms of such vehicles. The first railway to carry passengers was the Oystermouth Railway or Tramroad Company, which is now known as the Swansea and Mumbles Railway. The first passengers were conveyed by this railway on March 25, 1807, a fact that was apparently unknown to Samuel Smiles when he attributed to George Stephenson the design and operation of the first railway coach. This coach, which is shown below, took part in the procession that marked the opening of the Stockton and Darlington Railway on September 27, 1825. Smiles describes it in Volume III of his *Lives of the Engineers*, as "a very modest, and indeed a somewhat uncouth machine." It had a row of seats along each side of the interior, and a long deal table fixed in the centre. The early horse-drawn rolling stock of the Oystermouth Railway retained the form of the road coach.



The first passenger railway coach of the Stockton and Darlington Company, 1825. From *Lives of the Engineers*. Vol. III. John Murray, 1862.

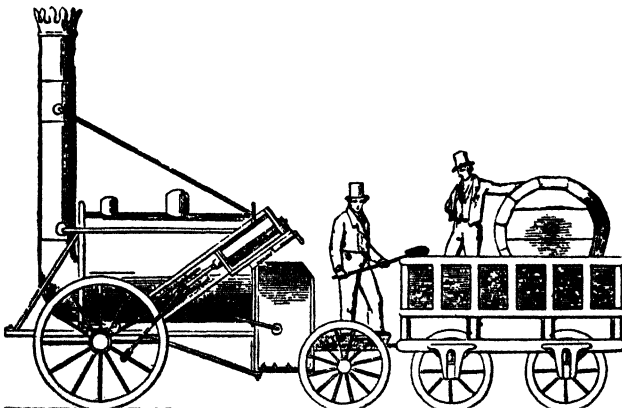
The prospect of accomplishment through the application of science inspired the great engineers—men like Thomas Telford, John Rennie, Richard Trevithick, George Stephenson and his son Robert. As pioneers, they had to fight hard for their work; and such men never realised that they were the only true industrial designers of their age. As we have seen in Chapter IV, they were inclined to be apologetic about their large-scale industrial architecture; only when they were designing locomotive engines and other machines were they liberated from the tyranny of a prototype or a fashion. When they were solving mechanical problems their minds were critically alert; they had no hesitation in identifying progress in invention. For example, George Stephenson's opposition to the proposed substitution of atmospheric pressure for independent steam locomotives on railways, showed how clearly he understood that the principle of the atmospheric railway was merely an elaboration of the old winding rope for drawing trucks along rails—an outmoded system in a new and specious guise. He said: "*It won't do*: it is only the fixed engines and ropes over again, in another form; and, to tell you the truth, I don't think this rope of wind will answer so well as the rope of wire did."² The atmospheric principle for operating railways was applied by laying a pipe between the line of rails, and a piston inserted in this pipe was attached by a shaft to the underframe of a carriage. "The propelling power was the ordinary pressure of the atmosphere acting against the piston in the tube on one side, a vacuum being created in the tube on the other side of the piston by the working of a stationary engine."³

Mechanical inventions, practical and unpractical, poured out of all kinds of brains during the nineteenth century, but the outstanding achievement was steam locomotion, and railways and steam-boats within two generations changed the character of civilisation. Many inventions were far in advance of their time. For instance, the idea of a self-propelled amphibious vehicle is not new. The achievements of the Duck, the versatile motor vehicle that becomes a swift, light sea-going craft, were anticipated as early as 1804, by an American inventor, named Oliver Evans of Newport, Delaware. In that year, he built at Philadelphia, a five-horse power steam engine, working on the high pressure principle, which he placed upon a large flat or scow, mounted on wheels. Evans drove this machine up Market Street, Philadelphia, launched it into the Schuylkill, projected a paddle wheel from the stern, and steamed down that river to the Delaware. The engine was then dismantled and used for driving a small grinding mill.⁴



The early locomotives suggested by their form how much they had borrowed from the steam pumping engine: they seemed to be conceived for vertical rather than horizontal movement. Above is a locomotive designed for the Killingworth Railway in 1816 by George Stephenson. (From *Lives of the Engineers*, by Samuel Smiles. John Murray, 1862.) This particular locomotive was still in service in 1862, when this illustration was first published.

The "Rocket," which George and Robert Stephenson designed in 1829, had shed many of the external complexities that clustered about the Killingworth locomotive. The "Rocket" was built for speed: its lines foreshadow later developments in locomotives, though it bears about the same ancestral relationship to Pennsylvania Railroad S1 type, shown on plates 23 to 26, as the Java ape-man bears to modern man.



Steam coaches for road traffic had been tried out on paper, and some experimental models had been made during the last two decades of the eighteenth century. William Murdock, who was employed by Boulton and Watt at Birmingham, had built experimental models, and did much work on a steam carriage. William Symington produced a working model of a steam carriage in 1786. The machine ran on four wheels and consisted of a carriage with a locomotive at the rear end. But Symington's interests were diverted from road transport to marine engineering. It was not until the eighteen-twenties that steam carriages appeared on the roads. They were then regarded with the greatest alarm and hostility by many people, their uncouth appearance repelling even the most progressive and adventurous souls. The road improvements made in Britain between 1750 and 1830, and the increased speed of stage coaches and private vehicles, had aroused the greatest popular interest in traffic. The stage coach became a national institution; it held the affection and admiration of townsmen and countrymen alike, of passengers and people who never travelled. As the railway age began, so did the age of steam carriages. Some of them operated successfully for a short time, but they never captured public imagination and their designers seemed to be incapable of discarding the forms of horse-drawn vehicles. The ghost of the horse galloped before them, as eighty years later it was to gallop before the motor car, and only towards the middle of the present century has that ghost been effectually laid. (See illustrations on pages 102 to 105.)

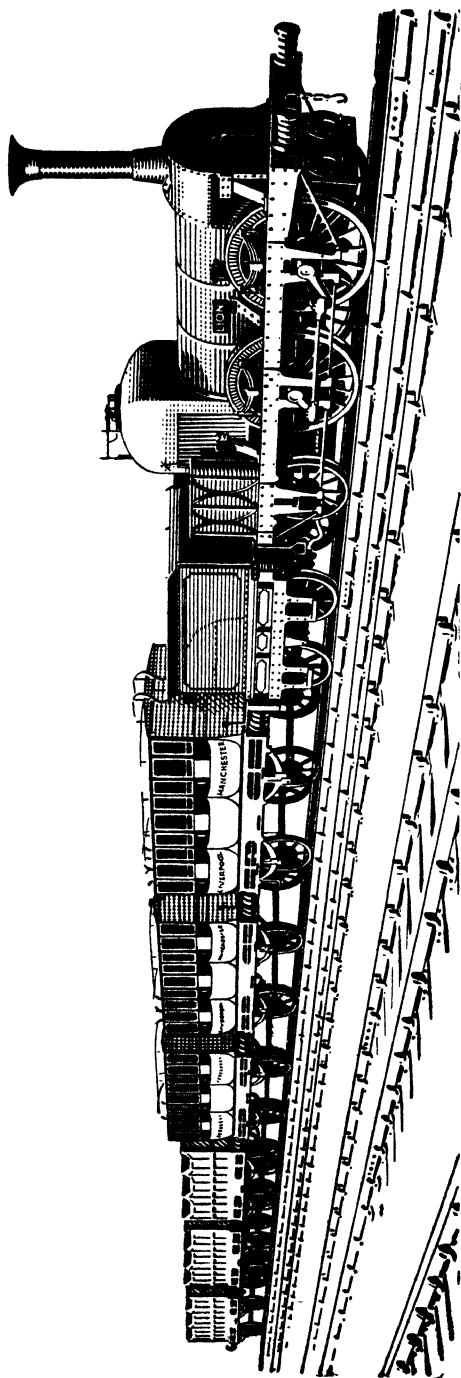
Although steam coaches and railway locomotives possessed mechanical originality, they began with many handicaps. The form of the early locomotive still bore a strong family likeness to its parent, the steam pumping engine; it seemed to be constructed for vertical rather than horizontal movement. Only when *The Rocket* was designed by George and Robert Stephenson in 1829, were later developments foreshadowed, for in this engine the up-and-down motion which had hitherto communicated the thrust of the piston rods to the wheels was abandoned. *The Rocket* is the great ancestor of the modern railway engine: earlier models, such as the Killingworth locomotive which George Stephenson designed in 1816, represented a *cul de sac* in development, as Neanderthal man represented a dead end in human evolution. But there is as much difference between *The Rocket* and one of the latest London, Midland and Scottish or Great Western locomotives, or the Pennsylvania Railroad type in whose design Raymond Loewy has collaborated, as there is between the Java ape man and modern man. Unfortunately the

scale of railway development was determined before steam locomotives were used. The gauge of the track was that of the horse-drawn cart. Certainly the first industrial revolution was hampered by many quite needless limitations. The men who saw so clearly what applied science could do for civilisation, even men with original creative minds like George Stephenson, could not make a clean break with precedents. Rails had been used for horse-drawn trucks with flanged wheels since the middle of the eighteenth century. The Hon. John Byng, in his visit to Coalbrookdale, had observed that "Every cart belonging to this trade is made of iron, and even the ruts of the road are shod with iron!"⁵

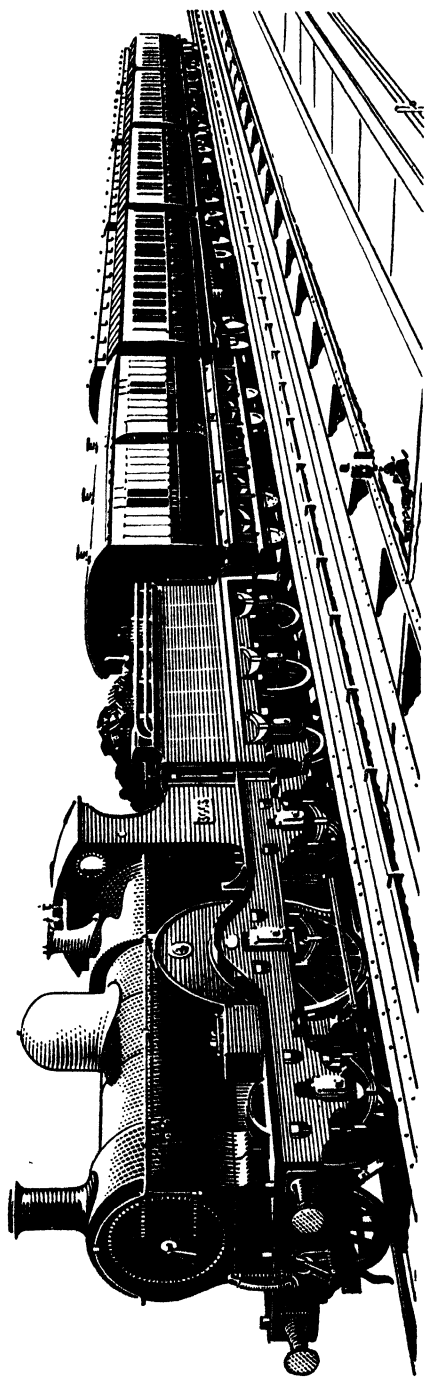
Nobody anticipated that locomotives would be able to travel at high speed. Great excitement was caused by a race between one of the engines on the Stockton and Darlington railway and a stage coach using the ordinary road. The locomotive completed the journey from Darlington to Stockton and beat the stage coach by about one hundred yards. But those early locomotives were not at first built for high speeds. Twelve miles an hour was considered dangerous; twenty miles an hour was tempting Providence. Perhaps it was, when locomotives had enormously high smoke stacks secured by stays to the sides of the boiler; but directly the idea of high speeds was generally accepted, the design of locomotives improved. Within half a century they had become trim and compact; superior to those untidy monsters that hauled Continental and American trains, with complex appliances exposed all over their external surfaces.

The design of railway coaches was hampered by the memory of the stage coach, and the habit of mounting private carriages on to flat trucks for transport by rail maintained the association with road vehicle forms. The early, first-class coaches on English railways were two or three conjoined stage coaches, forming compartments which each accommodated four people. This compartment system for coaches has been generally retained on British railways. Samuel Sidney was a little contemptuous about the design of this class of rolling stock.

"About passenger carriages, which every one can see and examine for himself, there is not much to be said. On the Continent, where they cannot afford to use mahogany, they use sheet-iron and papier mâché for the panels; in England, mahogany chiefly in the first class. When we began, stage coaches were imitated; there are some of the old cramped style still to be seen on the Richmond line; then came enormous cages—pleasant in summer, fearfully cold in winter,



The Lion hauling a train of first-class and third-class carriages. These early railway carriages on the Liverpool and Manchester line were merely conjoined stage coaches, three compartments to a coach, and a seat for the guard on the roof. (A drawing made from material supplied by the courtesy of the London, Midland and Scottish Railway Company.)



The first British corridor train built by the Great Western Railway in 1891. This was put into service between Paddington and Birkenhead in 1892. Although a new principle was being used in coach design, externally there was little difference between these eight-wheeled coaches with their compartments, and the four-wheeled coaches of the Liverpool and Manchester line in the early thirties. (This drawing is made from a photograph and is reproduced by courtesy of the Great Western Railway Company.)

without fires, which have not been introduced in England, although they are found in the north of Europe and America. A medium size has now come into favour, of which some fine specimens are to be seen in the Hyde Park Exhibition.

“On the Great Northern line some second-class carriages have been introduced, varnished, without paint, and very well they look. Economy again, and the increase of branches, have led to the use of composite carriages for first and second-class passengers all on one body. These, which were in use years ago on the northern coal lines, are now revived and improved.”⁶

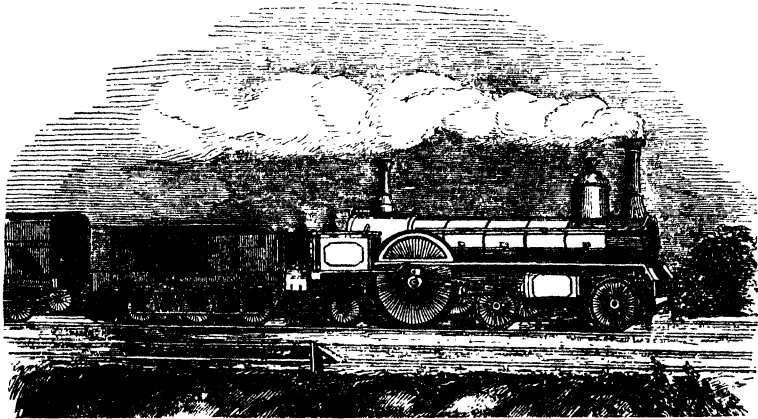
We have never completely shaken off the likeness of the stage coach, and even when the first corridor coaches were introduced on the Paddington-Birkenhead service of the Great Western Railway in 1892, compartments were still retained. It is only since the first world war that saloon coaches have become at all common on British main line trains.

In the United States a new form of railway coach was invented by George Mortimer Pullman. Born in 1831, Pullman invented the sleeping car, and his work was devoted not so much to mitigating discomfort in railway travel as to making such travel as luxurious and comfortable as possible. That great American trading axiom, “The customer is always right!” was honoured by Pullman’s designs—passengers on the cars should have everything they asked for, and even more. Sleeping cars, restaurant cars, club cars and observation cars, office compartments where the services of a stenographer could be hired, private parlours, shower baths, barbers’ shops—all these amenities of travel were foreshadowed by the work of the Pullman Palace Car Company which was founded at Pullman, Cook County, Illinois, in 1867.

Although Pullman’s work was original, and he was the inventor of the saloon car, it is probable that he was inspired by a prototype that was as obvious in America as the stage coach had been in England. The American prototype of the Pullman car was the river steam-boat, with its spacious saloons divided by aisles which linked open platforms at bow and stern. The early Pullman car was a miniature of the river steam-boat—a single decked saloon on wheels, with open platforms at both ends, and generous windows. Long before railroads had been made, the inland waterways of the United States were developed; and the rapid settlement of the Ohio and Mississippi valleys, the whole vast river-threaded area of the Louisiana Purchase, was made possible by the steam-boat. The growth of such traffic had long been foreseen by American leaders.

“The land trails were mere dirt tracks, beaten paths through the forests in some places—the most rudimentary roads. The way west was by water. Some years before he became President, Washington had foreseen that in the navigation of the Great Lakes and the streams that flowed westwards to join the Mississippi, lay the key to the traffic problem of the enormous territory for which the United States Government was responsible.”⁷

As early as 1790, when Washington was still serving his first term as President, a paddle steamer was in operation at Philadelphia. An

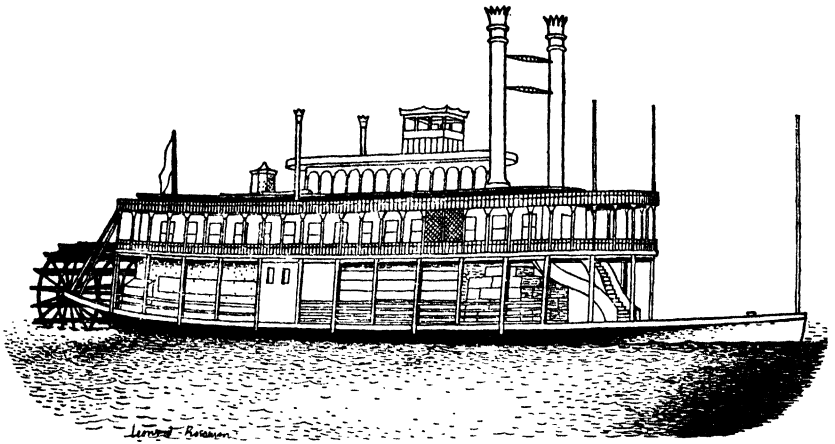


A London and North Western passenger locomotive in the early eighteen-fifties. This is the next stage of development after the Lion, the locomotive shown hauling a train on page 110, and also on Plate 20.

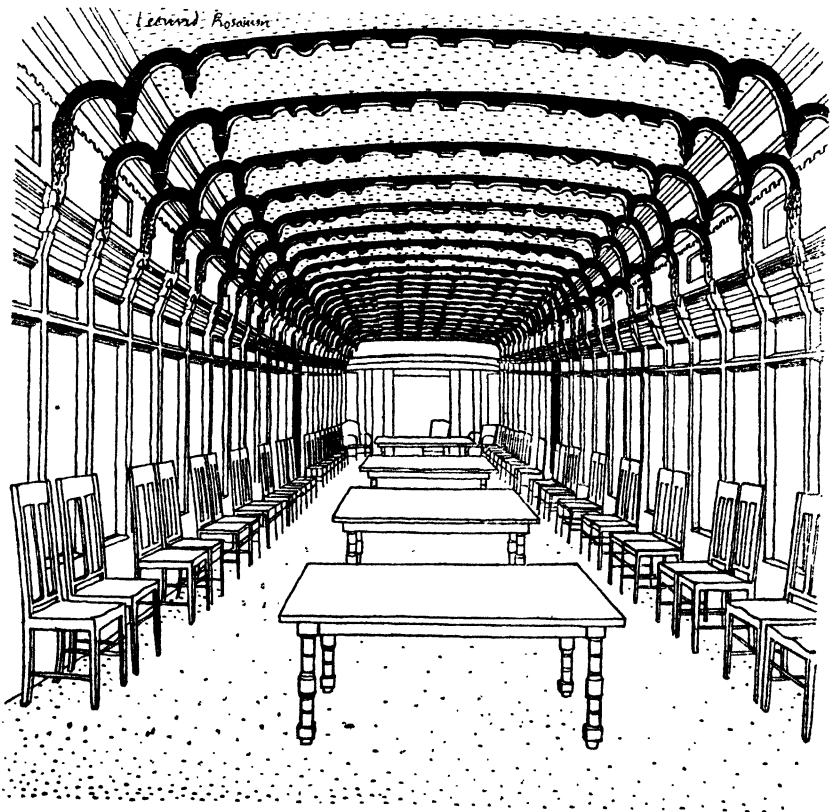
English sea captain, named Samuel Kelly, mentioned in his diary that he has seen the vessel “stemming the tide at the rate of about four miles an hour. The steam worked paddles under each quarter, which pushed it along, but I was informed that the friction was so great that the works often wanted repairs.”⁸

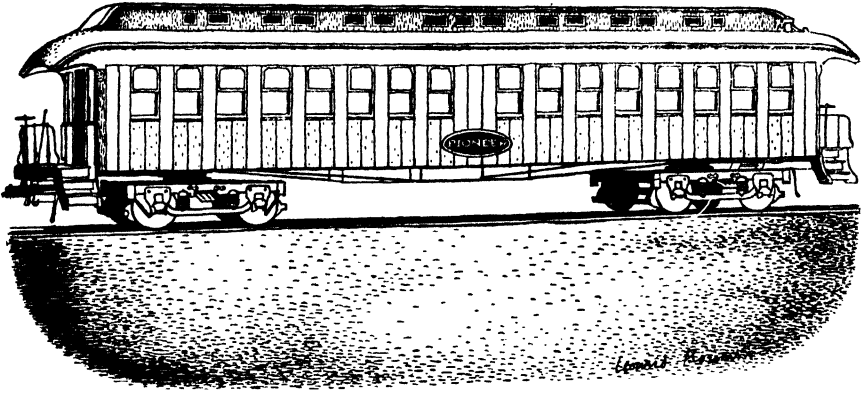
The river steam-boat in America had acquired its own special form, and had not passed through any transitional stage, when it was half sailing-ship and half steam-boat. It had a far longer active life on American waterways than the stage coach on British turn-pikes. One of the most vivid and informative records of this early American river traffic down to the days of the Civil War, is Mark Twain’s *Life on the Mississippi*. Railroads ultimately supplanted the river steam-boat.

In Britain the form of railway engines, progressively improved

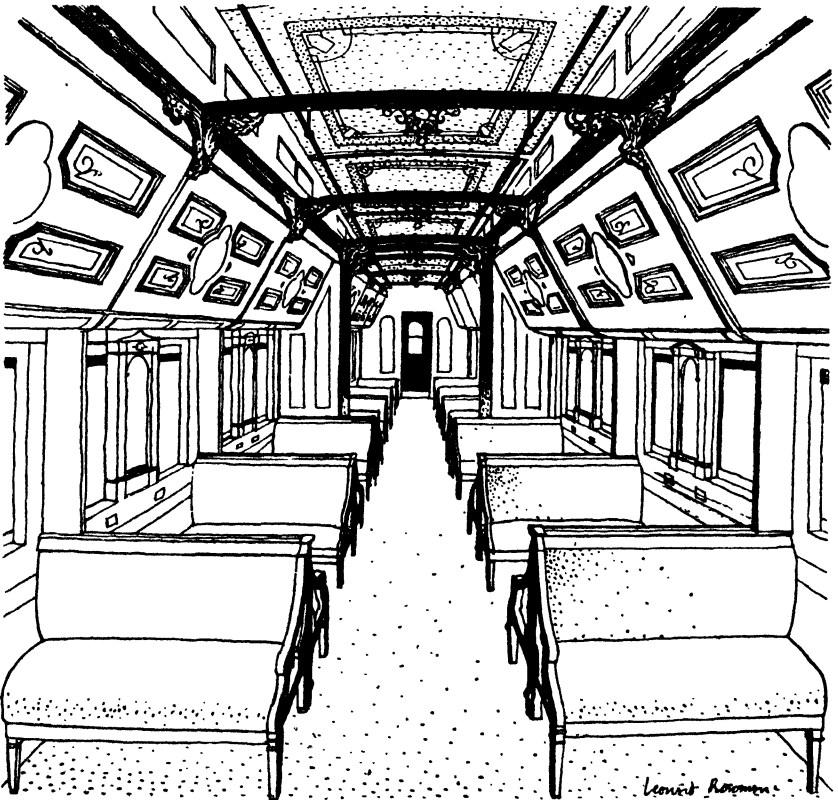


The American river steam-boat showing the open platforms at either end of the saloon. The interior of the saloon is shown below. (Drawn by Leonard Rosoman.)





One of the first American Pullman cars, with open platforms at either end. The interior of the saloon is shown below. Compare this with the steam-boat saloon on the opposite page. (Drawn by Leonard Rosoman.)



throughout the nineteenth century, showed how engineers had become masters of industrial design. The "Cardean" class of express engine, designed by J. F. McIntosh and in operation on the Caledonian Railway at the beginning of the present century; the Great Northern, Great Western, and London and North Western locomotives enjoyed a refinement of line, and a most appropriate external finish, anticipating what has been called "the modern movement" in design. Unknowingly, these engineer designers were making almost the only contribution to the industrial art of their time. The significance of their contribution was unremarked by their contemporaries. Anybody outside professional engineering circles who took an undue interest in the appearance of such things as railway engines was considered juvenile; art was segregated in picture galleries; so-called designers were dabbling in handicrafts or searching the past for ideas, and the industrial designers of the Victorian period were almost all anonymous. Yet these men were key technicians, and had more of them been working with their trained imaginations throughout industry, they would have given us a century of great industrial art. But educated people, whose taste formed or encouraged fashions, had listened to Ruskin and Morris, and had acquired a superiority complex about industry. They said, in effect, to the manufacturer: "You are a coarse fellow! You destroy the countryside, puff foul smoke into the air, and the goods you sell are machine-made! What do *you* care for art?"

"I've no use for this art nonsense," was the not unnatural reply; "as far as I can see the whole object of it is to put me out of business, and I'm not in business for my health."

And so the unproductive "you're another" type of argument would proceed, indefinitely, inconclusively, and nobody missed the key technician whose work could have civilised and improved industrial production. Yet he was there all the time.

THE REVIVAL OF HANDICRAFTS
AND THE ARTIST-CRAFTSMEN

ENGLAND has a tradition of skill that reaches back to the centuries before the Norman conquest, to a time and a civilisation now forgotten, when many inventions were made, customs were being slowly but firmly established, and craftsmen were learning how to subdue and fashion wood, iron and stone. The name England is used deliberately; for until the beginning of the eighteenth century Scotland contributed little to the arts and crafts, a fact which astonished Dr. Johnson when he travelled in that country during 1773. He wondered whether it was a Scottish peculiarity "to have attained the liberal, without the manual arts, to have excelled in ornamental knowledge, and to have wanted not only the elegancies, but the conveniences of common life." After a tribute to Scottish literary achievements, he wrote: "Yet men thus ingenious and inquisitive were content to live in total ignorance of the trades by which human wants are supplied, and to supply them by the grossest means. Till the Union made them acquainted with English manners, the culture of their lands was unskilful, and their domestic life unformed; their tables were coarse as the feasts of Esquimaux, and their houses filthy as the cottages of Hottentots."¹

Wales, too, was backward in the development of crafts until the sixteenth and seventeenth centuries; but at that time English craftsmen already had hundreds of years of accomplishment behind them. The woodworkers began to acquire their mastery of material as shipwrights and carpenters long before the days of Alfred. "In time, the skill thus acquired by woodworkers was reflected in building. In Norway, for example, a remarkable and beautiful architecture of wood grew up; in England, woodworkers profited generation after generation by the slow spread of ideas that had been tried out in the course of ship-building and which taught builders new ways of using timber in houses and churches, particularly in roofs. Towards the end of the Anglo-Saxon period, great skill in woodworking existed in England, and it arose from a partnership between forester, shipwright and builder; their know-

ledge was pooled, their skills were interchangeable. In the Saga of King Olaf Trygvesson, there is an account of the building of a ship called *Long Serpent*. The master-shipwright was Thorberg Skafhogg, and he invented an early form of streamlining. When the carpenters were planking the ship, the king inspected it, and discovered that 'somebody had gone from stem to stern, and cut one deep notch after the other down the one side of the planking.' The king was dismayed, until Thorberg chipped the planks so that the deep notches were all smoothed away, which vastly improved the shape of the vessel. This happens to be recorded, but hundreds of unrecorded ways of shaping wood, new methods of jointing, and new associations of wood with other materials, must have been thought of, century after century, by men who did most of their thinking with their hands, and whose skill we can appreciate today from the evidence provided by the woodwork and stonework of mediaeval churches, palaces and guildhalls."²

Carpenter, joiner, smith and mason established and extended their skills, century after century, and ancillary trades—those of the plumber and glazier, plasterer and tiler—flourished as building technique improved. The standards attained by craftsmen in the fourteenth and fifteenth centuries had a peculiar excellence, derived partly from pride and pleasure in the exercise of skill, and partly from the vigilance exercised by the guilds over the proper use of various materials and the thorough training of apprentices. The designer in the Middle Ages was nearly always an executant craftsman.

This period of English civilisation has been subjected to many years of sentimental misrepresentation; and although the works of Dr. G. G. Coulton and other scholars are available as correctives, the unrealistic and picturesque view of Mediaeval England has acquired a large popularity. But apart from a legend of social, economic and artistic felicity, the Middle Ages have bequeathed to England an interest in skill, a love of adroit and subtle ways of handling tools and materials and processes; and although methods and tools and opportunities may change, the man who was a fine locksmith in the fourteenth century had his counterpart in the clock-maker of the eighteenth while his contemporary representative may be a maker of scientific instruments or the master designer of such machines as the Mosquito or the Spitfire. Much of this skill was diverted to the needs of mechanised industry; the man who would formerly have practised a rural craft, became a mechanic in the nineteenth century, and his interest was transferred to the

mechanised methods used for making things, rather than the form and character of the things made. To such men, the machine was a super-tool; and their pride and interest in work were inspired by the performance of the machines they operated.

With the development of industry and of the new and often superior and alertly intelligent class of mechanics that served it, the economic significance and the rewards of the men who practised handicrafts diminished. The mechanic was associated with commercial enterprises; the health of a commercial enterprise was, and still is, shown by its ability to pay its way and to make profits; and the mechanic shared in the rising prosperity of industry. The handicraftsman was economically depressed because his old pre-industrial scale of pay for work was maintained. "The wage of a qualified carpenter in grandfather's time was seventeen or eighteen shillings for a week of sixty hours," wrote Walter Rose, when describing an old country business in his book, *The Village Carpenter*. "This, at the time I commenced work, had risen to twenty-one shillings. Along with the low wage went an expenditure of labour that would not be tolerated today."³ The craftsman could not compete with the machine, and except in the country districts where there was still employment for him, he disappeared. Very often his skill would be partly used, for in many branches of industry numerous operations depended upon the hands of individual craftsmen—such as furniture manufacturing, glass-making, iron-founding and pottery. Apart from such activities, where individual skill was contributory, the handicraftsman gradually became a rural survival, engaged chiefly in the building arts and crafts, in the making of farm vehicles and implements, in saddlery and blacksmith's work. All over the country small businesses, often run by families, are still active, masons and tilers and thatchers, joiners, carpenters, plumbers and smiths. Many of them, unknowingly, use methods that have remained unchanged for four or five hundred years. For example, a small firm of builders in the Cotswolds that was in existence until just after the first world war, would build fireplaces exactly as they were built in early Tudor houses. The members of the firm worked without drawings; they were not consciously or unconsciously "copying" anything: that was *their* way of building a fireplace, and *their* way, transmitted through twelve to fifteen generations, was the way generally used in domestic architecture in the late fifteenth century. These country craftsmen, working independently or in small family businesses, are survivals; they are *in* our commercial machine age, but not *of* it; and they remain active because, like most revolu-

tions that have occurred in England, the first industrial revolution was ruthless without being thorough, as the second industrial revolution may well be thorough without being ruthless. It is not the concern of this chapter or of this book to discuss the future of rural arts and crafts; but they exist, they form an expandable nucleus, and they are not incapable of growth.

Some industries that had been based upon the individual skill of craftsmen, made a successful and productive transition to mechanical methods. The introduction of such methods enlarged the craftsman's capacity, "speedily extinguishing all irksome and unintelligent labour," as Morris said, and created fresh opportunities for the exercise of skill. The most successful example of this completed transition is afforded by the printing industry, which allows the work of creative designers and trained craftsmen to flourish, encouraging the former to produce new type faces, giving typographers opportunities for experiment and invention, and employing skilled compositors. The original creative work that is lavished upon the printing industry can be translated mechanically without loss to the original design.

There are today, scattered about the country, individual artist-craftsmen or groups of artist-craftsmen, many of them doing what amounts to research work in design which indirectly benefits contemporary industry. Few of these skilled and highly individualistic craftsmen are conscious of giving this indirect service; some of them are deliberate isolationists so far as the commercial machine age is concerned, for they dislike it and despise its motives. Trade, business and industry, they say, represent a sordid pursuit of profit. But as they believe that the labourer is worthy of his hire, they sell their own productions for such enormously high prices that they can only be acquired by wealthy people.

The phenomenon of the hermit craftsman, detached from and contemptuous of industrial and economic life, has occurred during the last sixty years, and is one of the results of the teachings of William Morris. Perhaps the fairest and most discerning analysis of Morris's motives and prejudices has been made by Francis Meynell in a lecture on "National Design in Printing," when he said: "Morris rejected the machine for all but the dirty jobs because he believed that the *industrial* revolution would be halted and turned back by a *social* revolution. That belief permitted him, induced him, to think only of Man the Maker. But the social revolution never came, and the machine offers Man his fun not as *Maker* but as *User*. That is the compensation of the machine-age—more consumer goods. It is

also our problem—how to make the *more* into the *good* as well. Unfortunately, by and large *our design education still remains firm based on the Morris protest against the machine.*"⁴

William Morris gave a unique, creative, though reactionary interpretation to the Romantic movement. He was born in 1834, and was the son of a comfortably wealthy broker. He was educated at Marlborough and at Exeter College, Oxford. The library of Marlborough College, which was one of the new public schools when Morris entered it in 1848, contained many books on archaeology and architecture. When he went up to Oxford, he had a knowledge of English Gothic architecture that, as Montague Weekley points out in his short and excellent biography of Morris, would have done credit to an ecclesiastical antiquary. "His reading was accompanied by visits to churches, and already he showed a keen observation of architectural details and the ability to describe buildings from memory; his gifts in this respect seem always to have been extraordinary."⁵

He was temperamentally attuned to the past, and he created a splendid and glowing picture of the Middle Ages in England. Cobbett and Sir Walter Scott and the Gothic Revivalists had prepared his mind for conversion to the view that mediaeval civilisation was something rich and fine and fair and brotherly. Had he lived today he would no doubt have said that it was "socially integrated." Elsewhere an account has been given of his ideas and how they animated his vast output of work, and the paragraphs that follow are condensed from *Men and Buildings*.

Morris looked back, and by the exercise of a convenient editorial faculty ran a mental blue pencil through all the miseries, limitations, ills and fears of the Middle Ages. For him the age of the mediaeval craftsmen became an illumined manuscript, unsoiled by ugly facts, shining with bright colours and packed with inspiring texts. He soon abandoned the idea of being an architect, partly because the architect of the mid-nineteenth century was a drawing-board man who dealt in "styles," but chiefly because the arts and crafts had dissolved partnership with building. He wanted to see houses and cities growing into beauty under the hands of craftsmen: he wanted wood and stone to be carved freely and surfaces to carry a burning splendour of decoration.

The Red House that Philip Webb built for him at Upton in Kent, illustrated this ambition, and gave a new shape to the romantic movement in domestic architecture. It was two-storied with walls of red brick and a high-pitched red tiled roof. The plan was L-shaped.

(For some reason unknown, it was planned so that the sitting-rooms, the dining-room, the drawing-room and the hall, faced north.) It had a careless and comfortable independence of character: its oriel windows and gables were unostentatiously romantic. Within, the furniture and decoration were strongly individual, but their anti-quarian flavour was incidental. The house was a sincere attempt by some singularly gifted people to solve an architectural problem from a particular point of view.

Morris and the group of artists who shared his sympathies felt that architecture should arise naturally and joyfully from a revival of the crafts, and that the work of a brotherhood of craftsmen must transcend the tyrannical harmonies imposed by the Renaissance. Hitherto the Gothic revival had been a thirsty search for picturesque forms. Morris tried to resurrect the creative spirit of men who had made the mediaeval abbeys and guild-halls, and he devoted his abounding energy to mastering a number of crafts, not as an artistic dabbler, but as a skilled executant. His personal powers were considerable. He was a poet, a teller of tales, whose prose unrolled like some glowing tapestry, with the story vividly depicted in rich colours; and he was a decorative artist.

After the building of the Red House, Morris and his friends realised that every branch of common art in England was in a state of decay. It was impossible to buy well-designed furniture, fabrics, or wallpapers, and it was to elevate standards of design that the firm of Morris and Company was founded in 1861. Philip Webb, Burne-Jones, Rossetti, Ford Madox Brown, Faulkner and Marshall were associated with Morris in this venture. The firm was prepared to undertake church decoration, carving, metalwork, stained glass, also wallpaper, chintzes, carpets and furniture.

Handicrafts could be revived, or their extinction delayed, but the craftsmen could not live upon the joy of work alone, and the cost of living was higher in the nineteenth century than it was in the Middle Ages. Consequently Morris found himself perforce working for that relatively tiny section of the community that had both wealth and taste. Presently the costly products of organised handicraft were imitated by industry. Morris had, quite unintentionally, started a vogue for "hand-made" articles, giving manufacturers a new label for their wares. The machine was equal to the demand for "art" products; and the handicraft note was admirably simulated by speckling metalwork with mock hammer marks, leaving woodwork rough and heavy; and, where no external evidence of

handwork could be faked, "quaintness" of form or ornamentation became a selling point.

A few crafts had been precariously preserved or revived by Morris; but in providing opportunities for craftsmen to work, he had omitted to furnish them with the right customers. It was galling to have one's activities supported by the "arty" rich, while the "people" (as Morris thought) were starving for colour and gaiety and carving and folk-songs amid the reek of the factory chimneys and the hum of machinery. Before common art could return to their lives a social revolution would have to take place; so Morris, without bothering his head about any economic quibbles, became a socialist. Meanwhile his teaching gave fresh impetus to the romantic antiquarian movement, and established an exaggerated reverence for hand-work and handicraftsmen. Therefrom arose two evils: firstly, blind admiration of the antique, which begot the curse of sterile imitativeness and atrophied all critical judgment of design; and, secondly, the intolerance of the creative artist for machine production which has robbed modern industry of immeasurable advantages, and has made the designer a stranger to businesses where he should most properly be a partner.⁶

In all that the first industrial revolution had made possible, in the new knowledge, metallurgical, chemical and mechanical, Morris could find nothing for the people; nothing to replace the lost common art of England. Had he given his great abilities to solving the problem of relating design to industry, there might have arisen in the last quarter of the nineteenth century, an industrial art, vigorous in character and recognised by manufacturers, distributors and consumers. Instead, the work of Morris started the arts and crafts movement, from which arose various organisations, such as the Art-workers Guild which was founded in 1884, and the Arts and Crafts Society, founded in 1888. Such organisations attracted creative artists and designers, and promised them opportunities for expressing their creative powers—opportunities which were not apparently offered by industry. Under the influence of Morris and the people whose work he inspired, the arts and crafts movement did begin to re-establish respect for functional fitness; but as it was concerned only with restoring handicrafts and rehabilitating craftsmen, its effect upon industrial production was negligible. The movement attracted many excellent designers; it encouraged a generation of fine artist-craftsmen, men like Ernest Gimson and Sidney Barnsley. As a by-product, it increased the number of misconceptions about art, and reinforced the belief that it was something separate from life, some-

thing detached and isolated. Thus the artist-craftsman was segregated from contemporary life.

Lucid thinking about design was not encouraged by such developments. The confusion of competent craftsmanship with the ability to design was sometimes set forth in striking and musical phrases such as those employed by W. R. Lethaby, when he said, "Art is thoughtful workmanship." But although Lethaby exalted competent workmanship, he made many wise and clear statements about the function of machinery. Most misleading is his statement that "art may be thought of as the *well doing of what needs doing*." Most illuminating is his statement that "although a machine-made thing can never be a work of art in the proper sense, there is no reason why it should not be good in a secondary order—shapely, smooth, strong, well-fitting, useful; in fact like a machine itself. Machine-work should show quite frankly that it is the child of the machine; it is the pretence and subterfuge of most machine-made things which make them disgusting."⁷

Such criticism was conceived in the handicraft revivalist spirit. Discussions about the relation of beauty and fitness had continued since the days when Dr. Alison's essays were written, and all the thousands of words that had been printed and spoken on the subject were ultimately reduced to eleven by Norman Douglas in one of the essays in *Siren Land*: "There is a beauty in fitness which no art can enhance."

In Europe, William Morris was taken far more seriously than in his own country, and in Sweden particularly his work inspired the arts and crafts and also informed industrial art. Conditions in Sweden half a century later might even have reconciled Morris to industrial production. Dr. Gregor Paulsson, the Director of the Swedish Arts and Crafts Society, in a lecture given in 1931, on "The Alliance between Designer and Manufacturer in Sweden," said: "A big factory may have workshops where expensive articles of finest craftsmanship are manufactured by employees whose relations to the products, from the technical point of view, are the same as those of the craftsman in olden days. One cannot make the distinction of skill between the two, for the importance of skilled craftsmen in mass production must be emphasised. Indeed, mass production of high quality demands much more manual skill than handicrafts. It is a paradox but true. It is in the relationship to the manufacturing (and the selling) process that they have no connection with each other. The craftsman produces for his customer and the manufacturer for the market.

"In Sweden we have to a certain extent succeeded both in reviving handicrafts and improving mass production, and the improvement in mass production was dependent upon the revival of handicrafts."⁸

In England there were two principal monuments to Morris's teaching: the revival of the trade in antique furniture and other objects culled from the past, and the establishment of the independent artist-craftsman. These developments have been dealt with in greater detail in another book, *English Furniture*, and from the chapter that examines "Furniture Design under the Antique Dealers and Artist Craftsmen, 1900 to 1920," the following paragraphs sketch the history of the artist-craftsmen who were concerned specifically with furniture making. "The best effect of William Morris's work was his inspiration of certain young artist-craftsmen and architects like Ernest Gimson. To the work of such men as Gimson, Barnsley, A. Romney Green and, since the first world war, to Gordon Russell, we owe a big proportion of the original furniture design of the twentieth century. In the 'nineties and the Edwardian period, Mr. C. R. Ashbee was designing furniture and metalwork, also George Walton, and many architects were giving thought to the creation of furniture forms, including such designers as Mr. Baillie Scott, Mr. F. W. Troup, Mr. C. R. Mackintosh and later Sir Edwin Lutyens. Ernest Gimson and Sydney Barnsley together gave vitality to all that was best in the ideas of William Morris. Gimson met Morris in 1884. For twenty-five years Gimson lived and worked at Pinbury and Sapperton in Gloucestershire. He revived something that had been waning since the advent of machine production, namely, the ability of the craftsman to design for and with a material that he loved and understood."

Gimson was not only an executant craftsman; he was a designer. "It is important to recognise his ability as a designer, for it is sometimes supposed that an accomplished craftsman is by virtue of his manual dexterity a designer. The craftsman, left to his own common sense, may devise something that is fit for its purpose, but he may over-decorate it like any savage; he may be unaware of innumerable opportunities for refining the proportions of various members; he may achieve a solid straightforwardness, a rustic simplicity, but in the absence of a continuous tradition of furniture-making to nourish his invention and provide him with guiding precedents, he must improvise, and, unless he has the selective and inventive skill of a designer, his improvisations may be discords. By mastering the craft of woodworking, Gimson, the sensitive and accomplished designer, brought to furniture-making the individual genius it had

when he closed the Omega Workshops, but not before some fine pottery and fabrics had been produced. This group included some distinguished painters; and perhaps this was why the workshops concentrated on the decoration of surfaces and never approached any problem of industrial design.

The handicraft revival, started by Morris and continued by variously gifted artist-craftsmen, has achieved some interesting results and has led to the production of many individual things of beauty and original design, in furniture, pottery, metalwork and textiles. As teachers and advisers and independent research workers in design, artist-craftsmen have, during the last half century, invigorated and informed many branches of industry. They have seldom sought or secured direct contact with industry; but the example of their work, after a time-lag of five, ten, or even fifteen years, has occasionally affected the ideas of manufacturers. But the original "isolationist" spirit of the handicraft revival still darkens the whole subject of industrial art and designing for industry; the teachings of William Morris still implant prejudices in the minds of students of design, which only familiarity with intelligently organised industrial production can modify or eradicate. The work of Morris put back by fifty years the emergence, development and authority of the industrial designer in England.

EDUCATIONAL PROPAGANDA FOR
INDUSTRIAL ART, 1914-1945

PROGRESSIVE manufacturers who regard industrial design as a technical operation and employ the services of an industrial designer in the same normal businesslike way they would employ the services of a research chemist or a sales manager, are still in a minority. British industry is handicapped by memories of easy-going Victorian casualness about such matters, and by a belief that at heart the public is indifferent to anything connected with "art" or "good taste." The prevalence of this belief is easy to understand: we are not so far away from the Diamond Jubilee and the taste of that time as our rightly impatient educationalists and designers and artists like us to believe. The degradation of late Victorian design has been forgotten by many people; but its effects persist, and continue to suggest retrogressive ideas, even to young, receptive minds in modern industry.

By the end of the nineteenth century the form of nearly all industrial productions was so obscured by ornament, that it was sometimes quite difficult to recognise the original function of an object after the hack pattern-makers had done their tricks. It was an age of ornament, consistent in its copiousness. Sometimes an old film of the first decade of the present century will illustrate forcibly something which few people now remember, which is that forty years ago, clothes, buildings, vehicles, rooms and people were all of a piece. The background of the street scenes is composed of flimsy Gothic and bulbous classic façades, all overlaid with a thick coating of sugary decoration. The famous "illustrated interviews" with well-known people in the *Strand Magazine* of the 'nineties, disclosed how in their homes the wealthy and presumably cultured members of society overcrowded to suffocation every room they used, with massive or complicated furniture, and ornamental objects. The frilly and expanding draperies of the women, and the unwieldy hats that perched upon their piled-up hair, matched such backgrounds perfectly. We have inherited the background and forgotten the clothes. We have inherited the tendency to overlay everything with orna-

ment so that the purpose of an object is often completely obscured. Fine machine processes are spoiled because the manufacturer and the retail buyer who controls the distribution of the manufacturer's goods are uneducated in design, uninfluenced by any contemporary movements, and still believe that "art" is something extraneous, something to be "applied."

We are still struggling against the ever-present character and familiar nature of this heritage.

The last chapter has traced the diversion of critical and educational energy from the realities of the problem. Although various branches of handicraft were temporarily rejuvenated as a result of the Arts and Crafts Movement, industrial design was not seriously affected. But the subject received the intermittent attention of experts and critics, official and unofficial. In 1914 a joint scheme was framed and sponsored by the Board of Trade and the Board of Education for establishing an organisation to be called the British Institute of Industrial Art, which should be devoted to promoting industrial art. The genesis, early operation and subsequent curtailment of the scheme is described in the Gorell Report on Art and Industry, as follows:

"The scheme which was framed in 1914 was eventually launched in 1920, and the Institute received a Treasury grant in its initial stages. Unfortunately, the economic crisis of 1921-1922 put an end to any further Government support and correspondingly curtailed the scope of the Institute's programme and achievement. Thrown on its own resources and supported solely by voluntary subscriptions, the Institute has nevertheless organised Industrial Art Exhibitions in London, the provinces and overseas, and has also carried out valuable research work, besides maintaining within the building of the Victoria and Albert Museum a small permanent collection, on the lines originally contemplated, but on a more restricted scale."¹

In 1924, the Chairman of the Institute, Sir Hubert Llewellyn Smith, wrote what he described as "an essay towards the construction of a missing chapter of economics." Entitled *The Economic Laws of Art Production*, it was the most significant book that had yet been published on a confused and increasingly controversial subject.² It was written in subdued and unexciting language; it lacked the explosive and flashing phrases that are detonated by passion, for the author was examining a problem, not preaching a crusade. The level common sense of the book should have had a clarifying effect upon contemporary thought; but common sense is apt to be uninspiring, while the word "economic" repels.

In 1915 the Design and Industries Association was formed. Its founders included great business executives like Frank Pick, designers like Sir Ambrose Heal and designers and teachers like B. J. Fletcher and Harold Stabler. The reasons for its formation were concisely stated by Mr. C. H. Collins Baker in the introduction to the first Year Book published by the Association in 1922. He wrote. "Without being too historical we will state that the D.I.A.—the Design and Industries Association—was founded in 1915 by a handful of practical enthusiasts to combat the unpractical influences in British design and industry. They discovered that British things—furniture, textiles, pottery, printing, and so on—were often poor because they were not designed and constructed principally to do their job with maximum efficiency. Hence arose the chief article of their creed—'Fitness for purpose'—and the courage to restate that, if a thing were unaffectedly made to fulfil its purpose thoroughly, then it would be good art. Thus, at one blow, the formidable superstition that real art depended on the elaboration and disguise of multiplied ornament was challenged."³

Mr. Collins Baker pointed out that the founders of the D.I.A. did not shirk the facts of contemporary industrial life. "They did not," he said, "indulge the view that machinery, a vulgar, vile affair, caused all our modern ills. If they had a nostalgic hankering for the stage coach and the manuscript, they faced the fact like men, that steam and electricity, the printing press and the typewriter would endure and were capable of true service. They had the larger vision which perceives that the disease of modern design and industry was due not to machinery but to the imperfect comprehension of its limitations and possibilities. They saw that if modern design were frankly conditioned by the special capability of the *de facto* agent of production, fine art and craftsmanship were compatible with machine-made goods."

The Design and Industries Association with its slogan "Fitness for Purpose," unconsciously editing the phrase that illumined Lord Jeffrey's approval of Dr. Alison's analysis of beauty in architecture, began an educational campaign which still continues. It staged exhibitions of goods, models and photographs, drawn from many sources, showing examples of good design, and sometimes arranged for such exhibitions to travel round the country; it organised talks and lectures on design and printed a few pamphlets. In 1922 it began to publish year books, and the illustrations in the first two or three of these year books show how the D.I.A. was inclined to confuse industrial design with the revival of handicrafts. Anything that

illustrated the comeliness attained through functional fitness was likely to be included by the editorial board of the year book, whether it was the costly work of some exclusive and retiring artist-craftsman, or was mass-produced in a factory and sold for a few shillings. The research function of the artist-craftsman in relation to industry was not made clear; but because of the varied membership of the Association, it is unlikely that this function was ever overlooked though it may have been minimised. But the D.I.A. in its early years did not identify the objectives for its educational propaganda nor did it formulate a policy to direct its activities. For a time it issued a quarterly magazine, but this was discontinued, though pamphlets were still published at irregular intervals, including "Cautionary Guides" to various places in England, which showed how casually towns and their approaches had been disfigured. This particular activity had nothing to do with industrial design, and although it was a critical attack upon the worst manifestations of industrial and commercial architecture, it represented a diffusion of the Association's energy and resources, if the reasons for founding the D.I.A., set forth by Mr. Collins Baker in the introduction to the 1922 Year Book, were intended to inform its work. But the Association's freedom from official or semi-official restrictions and its enterprising readiness to tackle abuses and suggest improvements in any department of industrial art were sources of strength. Its funds were small, but its influence was far-reaching. It numbered among its members such men as Frank Pick, who became Chairman of the Board of Trade Council on Art and Industry in 1934 and was one of the greatest patrons of industrial design and commercial art that this century has known. As joint managing director of the London Underground Railway group, and later the vice-chairman of the London Passenger Transport Board, he was able in many visible directions to influence the character of London. The Underground Railway system, a century and a half ahead of its time, is an example of what railways might be like, if their rolling stock, their equipment, accessories and station architecture were in the hands of competent designers. Sir Lawrence Weaver, for some years the President of the D.I.A., was another influential patron of industrial design, and he was personally responsible for introducing many manufacturers to designers, and for founding a number of such practical working partnerships, which resulted in the betterment of industrial design.

Far more attention was given to industrial art after the first world war. The influence of the British Institute of Industrial Art and the D.I.A. was apparent at the 1924 British Empire Exhibition. When

EDUCATIONAL PROPAGANDA FOR INDUSTRIAL ART

the standard of display and the character of such things as notices and direction signs at that exhibition were compared with those at the pre-1914 White City Exhibitions, a relatively enormous advance was observable.

The Royal Society of Arts was not inactive in this inter-war period, and in 1923 they started an Annual Competition for Industrial Designs, and over a period of ten years the sum of £5,000 was expended on this scheme. In the report on the competition for industrial designs which the Society issued ten years later, it was stated that "the total number of competitors who entered for the various sections of the Competition was 1,131. Of these 724 were students of Schools of Art, and 407 non-students.

"The number of designs submitted was 2,623, divided as follows :

Architectural Decoration	306
Textiles	1,286
Furniture	88
Book Production	118
Advertising and Commercial Art	760
Miscellaneous	65
	<hr/>
Total for all sections	2,623"
	<hr/>

In announcing that the competition was to be discontinued, the Council of the Society stated that they believed the competition had had a powerful effect "in directing into more practical channels the work of the schools of art." The report also stated: "In far too many cases there is no vital connection between Schools of Art and Industry. Design is taught 'in the air' as it were, and without reference to its practical application. Nor, in most Schools, is any attempt made to find employment for their students when their course is finished. Over and over again candidates in the Competition have come to the Society asking for advice as to how to obtain work. They are pathetically ignorant of the ways of the world and have not the remotest idea either as to what kind of firms are most likely to be useful to them or as to how they should proceed to get in touch with them. Something has been done to guide these lost sheep into the way of employment, both by the Competition itself, and the exhibition of selected works, by which designers of merit are brought to the notice of manufacturers, and also by the Employment Bureau, where are kept the names of designers in search of work. By these

means a good many permanent posts and a large number of commissions have been found for successful candidates."

Since then the National Register of Industrial Art Designers has been formed. To this body, designers could submit specimens of their work, which were scrutinised by the appropriate selection committee and if approved the designer would be admitted to the Register and allowed to use the letters N.R.D. after his name. The responsibilities of the National Council of Industrial Design, which was formed by the Board of Trade in December, 1944, include the introduction of qualified designers to industries, and such liaison work, conducted from various centres throughout the country, should in time help manufacturers to find the right type of designer. But no help from official or private bodies, formed to improve standards of industrial art, can be effective, unless industrialists are convinced that design is a normal business operation, and that good design may be a potent sales factor. This point was emphasised by the Prince of Wales at the Royal Society of Arts dinner in November, 1933, when plans for the 1935 exhibition of British Art in Industry were formally announced. His Royal Highness said: "Our industries have been developed by scientists and technical experts of all kinds, they have been identified with every branch of industry where they would make for improvement in production or distribution. All forms of experts, except artists, have been employed because manufacturers have not recognised how the artist can sometimes help in the design and the consequent sale of a commodity."

The selling power of industrial design is understood in the United States; how well and thoroughly is explained in a paper by one of the leading industrial designers of America, Raymond Loewy, Hon. R.D.I., which was read before the Royal Society of Arts in December, 1941. This paper, entitled "Selling Through Design," is reproduced by Mr. Loewy's permission in the Appendix of this book (pages 226 to 234). No amount of pleading and urging and preaching can convince with the force of Mr. Loewy's facts and figures, drawn from his own personal business experience; no State-sponsored educational propaganda for good design has the authority of commercially successful practice to support its claims. Although a few progressive British manufacturers are beginning to realise that the industrial designer is the missing technician in industry, they have still to realise that he is a secret salesman.

Educational propaganda organised by official bodies, and by such active and virile organisations as the Royal Society of Arts and the Design and Industries Association, is far from ineffective. Many

practical suggestions have been made to British industry, by exhibitions and publications, planned and carried through chiefly by private educational enterprise. Two examples of such work are outstanding, namely the exhibition of British Industrial Art in Relation to the Home, organised by the Design and Industries Association, and held in London at Dorland Hall in the summer of 1933; and the exhibition of British Art in Industry, organised by the Royal Society of Arts in collaboration with the Royal Academy, and held at Burlington House in January, 1935. The former was a stimulating demonstration of what able designers could do with modern materials and processes; but as the exhibits were largely designed for the special occasion, they were unrepresentative of contemporary industrial art. There was an air of prophetic unreality about the exhibition, as indeed there must be about all such exhibitions that are not exclusively concerned with showing the actual results of good design in factory-made goods. The Burlington House exhibition showed upon a much more ambitious scale what inventive designers could do with modern materials. There was a preponderance of luxury articles, but some new and startling possibilities were shown in the section devoted to plastics which roused the interest of the public and the press. The ramifications of that interest, and the possibilities of those chemically produced materials in relation to industrial design have demanded a book to themselves.⁴

The occasion of the exhibition of British Art in Industry inspired various critics and writers to produce books on the subject, timed to appear just before or during the exhibition. Industrial art was "news" and the public recognition of its importance at the home of the Royal Academy was an opportunity not to be missed by those who were interested in elevating standards of design. The original edition of this book was published then in honourable and varied company, which included Mr. Geoffrey Holme's *Industrial Design and the Future*;⁵ Mr. John de la Valette's *The Conquest of Ugliness* and Dr. Herbert Read's *Art and Industry*. Mr. Holme's book contained questionnaires, vivid illustrations and a gentle trickle of tranquil optimism about the subject. Mr. John de la Valette, one of the principal organisers of the exhibition, edited the book he called *The Conquest of Ugliness*,⁶ gathering champions who wrote on the various sections of the Burlington House show. There were other books, but the only work that really mattered was Dr. Herbert Read's *Art and Industry*.⁷ The first edition was published in a large, rather unwieldy format, with the text printed in double columns; the maximum irritation for the reader being provided by the "stunt" typography

then fashionable. The second edition, issued in 1944, is more convenient to the hand and kinder to the eye; it is compact and well illustrated, and although some of the original illustrations have been omitted, and others changed in size and placing, the book has only been improved by these second thoughts. There is no re-writing, and Dr. Read relies upon occasional footnotes to bring the text up to date. *Art and Industry* remains, firmly and indisputably, the authoritative work on the subject of industrial design and its relationship to contemporary civilisation. It is also the most readable of books, written with an austere lucidity that stirs the mind, impresses the memory, and rouses the controversial spirit. The book is divided into four parts: I. The Problem in its historical and theoretical aspects. II. Form. III. Colour and ornament. IV. Art education in the Industrial Age. In the final paragraph of Part IV are two sentences which indicate the author's views about the whole subject. "But in the end," he tells us, "we shall find that the fundamental factor in all these problems is a philosophy of life. The problem of good and bad art, of a right and wrong system of education, of a just and an unjust social structure, is one and the same problem." Dr. Read's philosophy of life unsheathes all the prejudices of those who believe that there is something to be said for the social and industrial system that has evolved in this country, and which nourished the genius and encouraged the enterprise that gave to our fighting men in the second world war such superb examples of industrial design as the Spitfire and the Hurricane. He betrays a love of the frozen logic, the purposeful tidiness, that chills and dehumanises so much of the thinking and writing that is done in the name of "the modern movement in design." For example, in the original edition of *Art and Industry* the "B" Amplifier Output Switching Relays at Broadcasting House were illustrated on the same page as an air-photograph of the settlement at Dammerstock, Karlsruhe, Germany, designed by Gropius, Haesler, Riphahn and Grod. The serried rows of engineering units, and the grim, white ranks of houses, standing up to attention, were not selected as awful warnings of what happens when designers sacrifice their humanity to the false goods of witless functionalism. Dr. Read positively approved: he said in the caption: "The resemblance between these two illustrations is not merely fortuitous; the same laws of design end in the same effects of harmony." The omission of this page from the second edition is an advantage; for if books like *Art and Industry* are to perform the task of enlightening the potential patrons of industrial design and educating new generations of industrial

designers, they should not disdain our national love of variety and our just impatience with regimentation. It is regrettable that Dr. Read's strictures on British industrialists have been allowed to remain in the new edition. In Section 13 of Part I he still libels intelligent and progressive directors of modern industry in these sentences: "Though the present-day industrialist is aware of the commercial value of good design, no spontaneous improvement is likely to come about because now . . . industry is run for the most part by people who have no understanding of the meaning of art, and no inclination to resign any of their functions to the artist. They will continue to defend their inferior designs against superior designs from abroad by higher and higher tariffs, and so long as the industrialist can rely on this protection, the consumer will have to be satisfied with clumsy cutlery, crude textiles, ugly furniture and uglier houses."

Since Dr. Read wrote those words in 1934, Nature, operating through the climate of these islands and the inevitable senescence that awaits us all, has largely eliminated the obstructive generation of industrialists that perpetuated Victorian memories of "applied art" and easy profits. A new, progressive generation of men is gaining control of modern British industry. If these new industrialists with receptive minds are ignored, if their readiness to recognise industrial design as a business operation and the industrial designer as a qualified technician is unremarked by responsible critics and teachers, then the rift between art and industry will remain. In the last sentence of his book, Dr. Read reveals his longing for "a change of heart" in human affairs: he should at least be comforted by the fact that during the nineteen 'thirties a change in commercial common sense occurred. The fact that such a change was under way was not perhaps apparent when Dr. Read first wrote *Art and Industry*; and a writer who did not enjoy frequent and familiar contact with industrial organisations, which furnished opportunities for observing their work and the way their research and production programmes were planned, might conceivably miss new trends. But the difficulty that besets critics and writers like Dr. Read in any examination they make of contemporary industry, is their fundamental disapproval of the existing social and economic system. In the interval between the world wars, intellectual writers and critics have launched a propaganda of disparagement against trade—one of the oldest and most civilising forms of human activity. All problems such as improving standards of industrial art could be solved, they suggest, if trade, industry, the profit motive and the whole existing economic set-up were swept away and replaced by their own particular version

of Utopia. Even Dr. Read in a lecture on "The Future of Industrial Design" (delivered in 1943) has stated that the profit motive is the most obvious of various obstructive features "which effectively prevent the free use of good design."⁸

Much of this vicarious disapproval of the commercial machine age arises from the sense of outrage experienced by tidy minds at the profusion and variety and wastefulness of competitive industry. Such minds reject or ignore the benefits derived from the incentive of competition. The nearest approach to an objective survey of the operation of design in various industries is Dr. Nikolaus Pevsner's book, *An Enquiry into Industrial Art in England*, published in 1937.⁹ Dr. Pevsner is a German who made his home in England early in the nineteen 'thirties, and has devoted much time to an intensive study of industrial art in this country. Formerly the Assistant Keeper of the Dresden Gallery and lecturer on the history of art and architecture at Goettingen University, he brings to his studies the neat thoroughness of an acute German mind, and sets forth his conclusions in clear and direct English. But Dr. Pevsner, perhaps unavoidably, has a fondness for logical orderliness: his mind is obviously shocked by the spectacle of untidiness. He believes that "a style of our age must be an unexclusive style, and its merits must be collective merits not distinguishing one individual or one class."¹⁰

There has been much talk among the exponents of the modern movement in design of an "international style," which is the product of a common approach to all problems of design—the approach of the functionalist, who, imposing his will upon an array of substances that have lost the obduracy and limitations of traditional materials such as wood and stone, arrives at an identical solution for the form of an object, whether he is practising industrial design in the United States, France, Germany, Scandinavia, Russia or Britain. The idea of an international style certainly appeals to those who love tidiness for its own sake. It is an orderly and compact belief, that all the loose ends of national taste and idiosyncrasy can be snipped off, tucked in, and everything made smooth in the interests of a convenient label. Writing of this, Dr. Pevsner states that "One of the reasons why England has been late in adopting this international style is the fact that more contrasts between classes still exist in this country than in those which are leading in the Modern Movement. The distance between the wealthy and the poor is larger in England than in Central Europe; the rich house looking richer and the poor house poorer, the clothes of the rich more perfect and of the poor more ragged. This is certainly one of the main obstacles to improve-

ments in English industrial art. Unless a further levelling of social differences takes place in this country, no steady development towards the aims of the Modern Movement is possible."¹¹

These fallacious conclusions seem to be based upon some very superficial observations of English life: the operative and sinister word is "levelling," for this implies the death not only of social and economic inequality, but of variety in taste. The British public, levelled up (or down according to the ideas of those in charge of the levelling process) are to become docile consumers of the manifestations of the modern movement in design, and are to have their national and regional variations of taste removed to make way for an international style.

It is easy to advocate sweeping social and economic changes—easy and indolent; but it appears to be an accepted preliminary to suggesting the sort of artistic and intellectual dictatorship that raises its ugly head in so many books and lectures and articles on the health and future of industrial art.

"Assuming there are only a thousand people in this country with a sufficient appreciation of the principles of good design, these thousand people," Dr. Read suggests, "if given a free hand, would be able to transform in a relatively short time the whole process of mass production—would be able, that is to say, to transform the whole character of our physical environment."¹² They would undoubtedly; but how would their fellow-countrymen react, and what would happen to industry? Such demands for a "free hand" to institute revolutionary changes, invalidate the case for improvement and progress in industrial art made so ably by many critics and teachers. To attempt the conversion of the industrialist, the manufacturer and the retail distributor by suggesting that their activities are discreditable denotes an imperfect acquaintance with human nature; but unfortunately a great amount of educational propaganda for better industrial art is tainted by the belief that all forms of business are anti-social, if not positively criminal, and that leads back to Morris and his hopes for a social revolution that would change everything. Morris and Ruskin obscured the whole problem of design because they were romantic reactionaries. Today the problem is in danger of being obscured because the critics and teachers and writers are often romantic revolutionaries. There is more to be learned from Mr. Loewy's paper on "Selling Through Design" than in most of the dissertations that attempt to identify all progressive industrial art with left-wing political beliefs.

Since the middle of the nineteen 'thirties, the volume of educational

INDUSTRIAL ART EXPLAINED

propaganda has grown: books, pamphlets, lectures, broadcast talks, and the consistent attention of such technical journals as *The Architectural Review*—which publishes a regular feature entitled “Design Review”—*Art and Industry*, and *The Architect's Journal*, all increase and enliven the general interest in the subject. In the Appendix there is a classified list of books and papers that deal with various aspects of industrial art (pages 220 to 225). It is far from being exhaustive; it is really a suggested course of reading for those who wish to carry their studies beyond the scope of this volume; but its range and variety reveal the healthy interest that the subject now commands.

THE PRESENT STATE OF INDUSTRIAL ART

NATIONAL indifference to the things which are seen is a comparatively recent social disease, dating from the rise of the first industrial revolution. This disease is widespread, though the Midlands, the North of England and Scotland are more intensively afflicted than the Home Counties and the south-western parts of the country. To what extent this regional resistance or receptiveness to excellence in the visual arts reflects the history of civilisation in the island of Britain is a matter for speculation; but it is certainly suggestive that during and since the days of the Roman province, the southern part of the country has been settled and has enjoyed the security which allows arts and crafts to flourish, while the North Midlands were comparatively undeveloped, save for the brief light of Northumbrian culture in the seventh and eighth centuries, which the Danes extinguished; the far North remaining barbaric for hundreds of years. As we have seen, Dr. Johnson remarked the absence of manual arts in Scotland prior to the Union. But North, South, East or West, public disregard for good design, and public ignorance of the existence of industrial art, are now common, and have been so for over one hundred years. In 1880 John T. Emmett had said that the public was "the great, unconscious enemy of art"; and although standards of taste have improved since then, the "artist" is still outside the scheme of things, still a queer, outlandish, incalculable creature in the view of most ordinary people. Not that art as a subject has been neglected; on the contrary, it has received any amount of specialised attention, and perhaps that is one of the principal causes of a state of mind that is common to all classes.

As long ago as 1908, Felix Clay had diagnosed the complaint and had expressed doubts about the wisdom of the conventional cures. In his book, *The Origin of the Sense of Beauty*, he said: "Schools of art and museums are instituted in order to fan the flame of artistic appreciation—that is suffering principally from the aloofness from life that this treatment does so much to foster."¹ The author's views must have been unpalatable to people who felt that culture should

be something exquisitely exclusive. He deplored the accustomed view of art as "something far removed from the sober business of life" and rather unkindly exposed the specialist's pretensions to superiority when he said "the more removed it is from reality and everyday life, the more those who practise it and enjoy it plume themselves upon being idealists. So tender a plant must be preserved from the rough contact of the world." He pursued the subject with unrelenting realism. "Art," he said, "has suffered incalculable damage from this idea of Separation from practical life: so strong indeed is the feeling, that we feel it to be in some way suitable that an artist should be a dreamer; unbusinesslike; standing aloof from everyday affairs. Thus the spirit and the only force that can make art live have been stolen away from it, and art, instead of being an influence irradiating life, tends more and more to become the plaything of our leisure hours. In the golden age of an art it is all pervasive; even the homely utensil of the kitchen will have its subtle appeal to the eye, because, where the artistic spirit is present, it is not sufficient that a thing should just do—it must look well; every product of the workman who loves his work, as an artist must, carries some indefinable but easily perceived suggestion of his feeling."²

When those words were written, the "homely utensil of the kitchen" and hundreds of other things about the house, about the office, about the streets, about the railways, and the vehicles that ran on them, were separated from art and often from elementary efficiency. A year earlier, in 1907, Professor Flinders Petrie had written a critical and disturbing book called *Janus in Modern Life*.³ The author denounced "the strange lack of thought and adaptability in common matters of everyday life." He listed a number of complaints to support this statement, and in view of later achievements which we now regard as commonplace, his list of defects in everyday life has exceptional interest. He said: "The daily loss of time, and cost in trivial matters, which affects thousands of persons, makes a heavy tax on the whole. For instance, such a simple matter as putting the offices of a terminal station at the ends of the platforms is still ignored at many termini; the name of a station is often hard to find, and is never once put up in most termini; the price of a ticket is often not to be discovered; the right types of carriages are only now being tried; after persevering in a wrong form for two generations." (Mr. Samuel Sidney's inventory of Euston's defects is recalled by this.) "In the streets the same lack of sense is seen in the immense omnibus system, which is difficult to use, especially

for strangers, owing to the lack of numbered routes and conveyances. It has been officially decided that the numbering of routes and omnibuses is beyond the powers of the London County Council; and we must be compensated by the pleasing reflection that something at least is too hard for that body. The thoughtless edict, however, was enforced that every vehicle must carry a white light in front, and all the distinctive colours of the tram-car lights were abolished, causing great inconvenience at night." (The achievements of the old London General Omnibus Company, since incorporated in the London Passenger Transport Board, become even more impressive after this description of Edwardian chaos.) "Even in the most recent appliances the same dullness is shown; electric fans are commonly placed where they only stir foul air, and not where they draw in fresh air or expel used air. The whole lighting system still throws away two-thirds of all its cost by lighting sky and walls as much as streets. In every direction it seems hard to believe that five minutes' thought has been given to matters costing thousands of pounds. If we trace such a mixture of design and of chance in any other subject it would lead to some curious speculations on the implied limitations of the directing Intellect. And in private matters it is the same; the extraordinary blunders and oversights in common trade work show that the most obvious details have not had a minute's real thought given to their arrangement. The result is an accumulation of difficulty and muddle which cripples, if not destroys, the purpose of the work. This persistent dullness, and incapacity for management and design, shows a defect of character which is a heavy detriment to the whole community."⁴

The community was beginning to pay the penalty for leaving out the designer and ignoring the artist. It was a time when nearly everybody thought of the artist as a painter, not as a man with a sensitive and creative mind, who might have mastered many skills, who might indeed in a less spectacular way have the versatility of a Benvenuto Cellini or a William Morris and the practical judgment of a Rennie or a Brunel. When enlightened patronage for industrial art is forthcoming, the results are appreciated by the public, as Frank Pick proved when he gave London the best designed 'buses and trolley-buses and underground railway trains and stations in the world, and through the Underground railway posters provided an opportunity for experiment in the graphic arts unparalleled in the history of commercial advertising. Such patronage is still rare.

During the Spring of 1944, Sir Kenneth Clark, the Director of the National Gallery, wrote an article in the *Sunday Times* which

explored the question of patronage and art.⁵ Few men now living have done more thoughtful and constructive work for art education than Sir Kenneth Clark, and he speaks with an authority to which few other people can pretend. He gave two examples of industrial patronage for art and design: the work of Frank Pick, and that of Mr. Jack Beddington, who, through the Shell organisation, before 1939 extended far-reaching and stimulating patronage to the graphic arts. The "Shell" guides, posters and press advertising were outstanding examples of commercial art.

Sir Kenneth Clark's article was followed by a volume of correspondence in the *Sunday Times*, and a letter written by Mr. Michael Rothenstein went to the root cause of our national indifference to art and the artist. Mr. Rothenstein said that much could be done to encourage talent and the appreciation of art *if only the general public had any positive feelings at all on artistic values*. He went on to say: "The artist, unlike the doctor, for example—whose advice is sought on all matters connected with bodily health—has no particular status: indeed, he is thought of as playing a quite superfluous role. But were it possible to imagine a society which had learned to use its eyes, which was thoroughly educated in appearances, and was therefore sensitive to its surroundings, we should see the artist forced to open his studio door at recognised hours for consultation on questions of design! Should the town hall be colour washed? Is it permissible to put steel furniture in a Tudor sitting-room? How should the main square be decorated for the Salute the Soldier campaign, etc.?"

"If people felt at all positively about any of these things we should have the needful starting-point. But, alas, they don't, as we all know. One need hardly comment on the extreme insipidity of the newer public-houses and cinemas, for instance; yet these are the most frequented places of public enjoyment.

"Taste springs from a desire for an environment at once ordered and expressive; it answers an essentially creative need. But ever since the industrial revolution human creativity has suffered a steady decay."⁶

Mr. Rothenstein has identified the real trouble, when he says that the general public are without positive feelings on artistic values, and, as a result of the public's deficiency, the artist has no particular status. In what previous period of civilisation has the artist lacked status? In what previous period of civilisation has the practice of the arts been ignored, and the function of the artist unknown, or even unsuspected? Only in those periods when civilisation has been submerged by a tide of barbarism. Not since the Saxon and Jewish

savages overthrew Roman Britain in the fifth and sixth centuries have we endured a period when the populace lived their lives uninfluenced by and largely unconscious of the visual arts. In the damage it has wrought, in the ignorance it has promoted and sustained, the first industrial revolution may be compared, not unjustly, with the ravages of the barbarian invasions of fifteen hundred years ago.

The few civilised people who lived out their precarious and broken lives in fifth-century Britain, must have looked back with longing to the peace, prosperity and culture of the Roman province. Precisely the same nostalgic longing for the past overtook cultivated men and women in the nineteenth century. As we know, artists and designers turned away from industry; encouraged by the romantic movement they looked back to the past, making little or no attempt to comprehend the queer, monstrous, barbaric thing called industry, that was bringing great riches to their country, but was repellently ugly, dirty and careless, and controlled by men as indifferent to civilised values as the Saxon barbarians had been.

When then could the artist do, but draw aside the hem of his garment, fearing contamination? Gradually, the idea became accepted that the artist, the man with the trained imagination, was a man apart: he had nothing to do with life, and of course nothing to do with business, commerce or industry. Most artists encouraged this belief. As a result "the artist now has no particular status."

It would be a poor prospect if the artist today was like the artist of fifty or sixty years ago. It would be an even poorer prospect if *all* industrialists were indifferent to the existence of the artist. Only artists who have outgrown the old suspicion and dislike for industry are of the slightest use as potential designers for industry. Only industrialists who have outgrown the nineteenth-century belief that the artist must necessarily be an unpractical visionary, are the slightest use as patrons of industrial art. But the massive and implacable ignorance of the public exists. It is an obstacle, whose dimensions can be diminished only by the right type of education. Meanwhile it is a regrettable but indubitable fact that the public is largely uncritical; as Mr. Rothenstein has said, they lack any "positive feelings" on artistic values.

Here is an example of the sort of thing the public is presumably prepared to accept. In an article published in 1944 on "British Post-War Motor Cars," Sir Miles Thomas, D.F.C., had some wise and interesting statements to make.⁷ Sir Miles Thomas is Vice-Chairman of the Nuffield Organisation, and Chairman of the Public

Relations Committee of the Society of Motor Manufacturers and Traders. He speaks for the motor industry with an authority comparable to that of Sir Kenneth Clark's when he is speaking about art. Sir Miles said that we should dismiss the idea that soon after the war we shall see cars vastly different from those which were in current production in 1939. He said:

"It takes at least two to two-and-a-half years to produce a really outstanding new car such as the optimists have in mind. This does not mean that the members of the motor industry are not enthusiastic about 'dream-line' cars. But the hard taskmistress of reality sets a measure for their pace of development, of which none is being done while the stress of war forces the energies of technicians into other channels."

Sir Miles then made, perhaps unwittingly, this devastating comment on the critical powers of the car-buying public:

"If we assume, therefore, that for a couple of years or so after the war the current 1939 models must continue, perhaps with a few minor embellishments and disguises, such as altered radiator shapes, then prophecy may not go so wide of the mark."

These words: "a few minor embellishments and disguises" take us back to the "Tower Bridge" approach to design. Sir Miles Thomas was speaking for the motor manufacturers and traders of Britain, who know what the public will take. What they will take presumably are a few minor embellishments and disguises; and they will no doubt cheerfully use the word *design* to describe those embellishments and disguises.

To an enormous proportion of responsible people in contemporary British industry, design still means disguise; the invention of twiddly bits, a proliferation of ornament "applied" to various objects, or bogus "stream-lining."

In referring to motor manufacturers and traders, we said that those people knew what the public would *take*, not that they knew *what the people wanted*. Although some people, generally the buyers of retail stores, are prepared to claim with complete confidence that they know what the public wants, it is a preposterous claim, because nobody knows. Even the public is ignorant of what it wants, as people lack positive feelings about artistic values, but that perplexing, independent British public, with its unpredictable moods, often knows emphatically *what it doesn't want*, as shopkeepers and government departments are continually discovering, in peace and war. In the commercial machine age, in a state where free enterprise is allowed to produce goods in the greatest quantity and variety, the

public, which represents purchasing power, must ultimately call the tune. But will the British public always accept with uncritical placidity the Tower Bridge approach to design?

Intellectual writers and critics, those highbrow reformers and publicists who are so convinced of the rectitude of their ideas and the immutable perfection of their taste, will say "No!" with a finality that discourages argument. But a good many people will say "Yes!" with suspicious eagerness. Among them are the art "snobs," who have been castigated with such relish by Dr. Herbert Read in his essay "To Hell with Culture!"—the cultivated, exclusive people who "put up an impenetrable barrier between the people and art, between the worker and 'culture.'"⁸ Then there are the retail buyers of large shops and stores, who are in the difficult position of "keeping up" their departmental sales figures. The accountant, drily demanding explanations about a "drop" in the monthly turnover, is the man the buyer fears. Consequently he avoids experiments, unless they are sanctioned by some higher authority. Some progressive stores make an allocation for experiments, and try out new things in various departments, and this absolves the buyer from the risks of personal responsibility. Occasionally some large retail establishment is tempted to flirt with the problem of improved industrial art; but it is usually the occasion of an exhibition of the work of some designer or group of designers. It is a transitory "stunt"; an encouraging but impermanent contribution to the general raising of standards. The experiment made in 1933 by E. Brain & Co., Ltd., of Stoke-on-Trent, was an exception. This firm of potters decided to produce some real contemporary work, and invited the following artists to create designs for China tea-services and earthenware dinner-services: Frank Brangwyn, Laura Knight, Ernest Proctor, Mrs. Dod Proctor, Duncan Grant, Vanessa Bell, Paul Nash, John Armstrong, Ben Nicholson, Barbara Hepworth, Allan Walton, Albert Rutherston, Graham Sutherland, John Everett, Milner Gray, Moira Forsyth and Gordon Forsyth. The results of this experiment were exhibited by a large London store in the autumn of 1934.

The arrogance of the retail buyer has had a deterrent effect upon manufacturing enterprise. Between the two world wars a situation had developed which deprived the public of the opportunity of seeing many new ideas in the design of the things they used in the furnishing and equipment of their homes. It arose from the incompatibility of the nervously reactionary distributor and the progressive manufacturer. The progressive distributor quickly discovered the

progressive manufacturer and ignored the rest, and bought most of his goods abroad. Before 1939 the situation was something like this:

THE RETAIL BUYER—OLD STYLE: SLOW AND SOLID

He began the job when people bought what the shopkeepers chose to give them, without complaining. It was a nice, passive, shut-eyed public in those days; it wanted things homely and comfortable and durable, and the poorer parts of it were quite happy with imitations of things that were homely and comfortable and durable. None of this "art" tosh: people who wanted *that* went and hunted in the rubbish heaps of the old curiosity shops. But the habit of chasing the genuine (or more often spurious) antique spread, and people began to want old shapes and patterns; a Tudor touch or ingloriously resurrected Queen Anne in their chairs and something a bit chintzey in the curtains; so he gave 'em good reproduction stuff at all prices, from high-class down to medium-class goods. They knew where they were with the old things, and so did the makers, and if you wanted a bit of variety, well, you could always order something original, a "Jaco" hallstand in mahogany instead of oak, or a coffin stool in walnut, or you could let yourself out with new colours in art pottery.

Of course there were little bits of fashion, but what went well in one year was generally good, with a few variations, for three or four years. The public wants the old English fireside comfort, and plenty of cushions, and they like things smartened up with a bit of ornament. That's why Jacobean was always more popular than the "Louis" style: too foreign, *that* was—rich, of course, but the English home wants its richness *solid*. A little of what you're used to does you good. Everyone starts keeping house with something they've got from Auntie or Dad, and they want something like they've started with. He knows what the public wants, and he never shows 'em anything else.

THE MANUFACTURER—NEW STYLE, OR HOPE DEFERRED, 1919-1939

He began to realise after the first world war that British Industry can't live by craftsmanship alone. To the reserves he set aside for research and experiments that maintained his technical efficiency, he began to add odd sums for even odder experiments, fees to

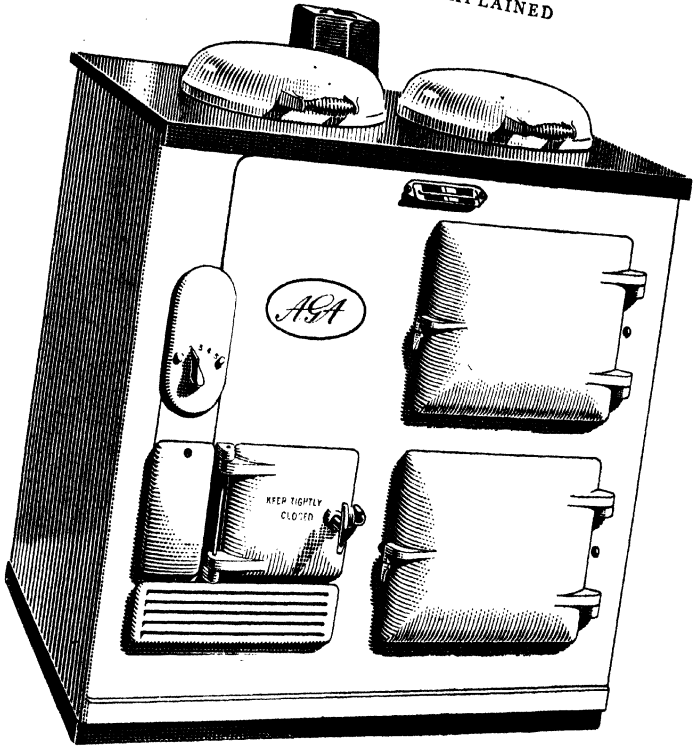
specialists in design for criticising his products, fees at last to industrial designers. He was as willing to experiment in design as he was to experiment in new technical processes, but the retail buyer nearly always said: "Now, don't go and make things difficult, old man; *we're* in touch with the public and we *know* what'll go and what won't—we couldn't possibly take more than a dozen, and that 'ud be a risk."

He didn't see quite why he should be expected to carry the baby all on his own, and he couldn't ruin his business by going direct to the public, so he ear-marked a little of the budget for new ideas and experiments, did some high-powered selling himself on a few retailers, because he believed that there *was* a market for the new stuff (it might be pottery, textiles, furniture, glass or whatnot), and perhaps just covered the cost of his experiments. And the old men on his board used the most blighting imprecations regarding his activities, such as "Idealist!" Every year it was more difficult to get those sums passed by the Board. He was looking ahead, and knew that ideas are vital tonics for the refreshment of a firm's commercial life, but he was obstructed by the accountant. Unfortunately none of his new stuff helped to sell the old-established stuff he made: his experimental designs for progressive twentieth-century taste and the customary products of his factory belonged to incompatible civilisations.

THE RETAIL BUYER—NEW STYLE: PROGRESSIVE

Ever since 1918 he had been trying to make people feel that they hadn't got to go to Paris or Vienna or New York for every new idea. But when he went abroad and bought well-designed things for his enterprising London shop, his customers said: "But everything's foreign in here—it's a scandal that you don't sell British goods." He would have done so gladly if he could have got them; but the manufacturers nearly always said: "Well, if you'll guarantee to take 1,000 we don't mind, just this once, putting down the money for the experiment!" And when the experiments were made, often enough the results were far more expensive than imported things of the same kind, despite import duties.

He wanted to give people a feeling that there was always something new and exciting to be found in his shop, and there was, but the bulk of it wasn't British made. Things were brought over from the Continent or from America—glass, pottery, light furniture, fabrics, fancy goods; and English manufacturers who couldn't or



Contemporary industrial design creates smooth, continuous surfaces when it is concerned with articles that have a mechanical or semi-mechanical function. This is the "Aga" heat storage cooker, designed by Dr. Gustaf Dalén; an appliance made largely of cast iron with a surface finish of light coloured enamel. (This drawing, made from a photograph, is reproduced by courtesy of Aga Heat Limited.)

wouldn't design were set the unseemly job of copying them. (Meanwhile those manufacturers went on offering the old, old goods: the stuff their fathers made so proudly and sold so easily; and which looked as dowdy and incongruous in a modern shop surrounded by things of twentieth-century design, as a 1910 motor car looks in 1945 traffic.) He didn't pretend to *exact* knowledge of what the public wanted; but he did discover that they'll always come to see something new, no matter how unusual, no matter what the price.

THE MANUFACTURER—OLD STYLE, OR LOOKING
BACKWARDS, 1919-1939

Ever since the first world war he had been hoping that pre-1914 conditions would return. All this modern naked stuff, bare walls, bare rooms, nudist movements—they're all symptoms of social upheaval. Presently people would settle back to their normal ways and want stuff that has some skill and ornament about it; anyway most people did want it, but couldn't afford to buy owing to the insane wages Labour had to be paid—can't produce the stuff cheaply if there's to be any profit. All that nonsense about new design: why it meant laying down thousands in new plant, spending good money to give people gimcrack made-in-Germany-looking stuff. Un-English! Worse! Unpractical!

The firm, founded by his great-grandfather, had grown to its present size by making things solid, not making 'em flashy. What's the good of some of these larky young retail buyers showing him glittering affairs from some Viennese bazaar and saying: "Why don't you make something like that?" What his father made and sold thousands of was good enough for him, and when the world gets back to normal then people'll be wanting the same good old solid stuff again. People, the British public, don't change, though the world gets out of joint now and then. Designers—? Well, young Alf (though he's nearly sixty now) who began in the pattern shop when he was a lad knew what they wanted, and he'd always been handy with a pencil—got an eye for colour too. We don't want any *art* in our business.

* * *

That was the general situation between 1919 and 1939, and in spite of it, standards of industrial art gradually improved during those twenty years. There were some outstandingly successful partnerships between manufacturers and industrial designers, which produced goods that were readily sold by distributors. There were such examples of excellence in industrial design as the Murphy Radio sets, designed by Gordon Russell and his brother, R. D. Russell; the electric iron designed by Christian Barman for H.M.V. Household Appliances; the Otto stove designed by Raymond Loewy and Charles Scott, for Allied Ironfounders, Ltd.; the Aga heat storage cooker, originally designed by Dr. Gustaf Dalén; the radio sets in moulded plastics designed for E. K. Cole Radio, Ltd. by Misha Black, Serge Chermayeff and Wells Coates, to name only a few. In industrial

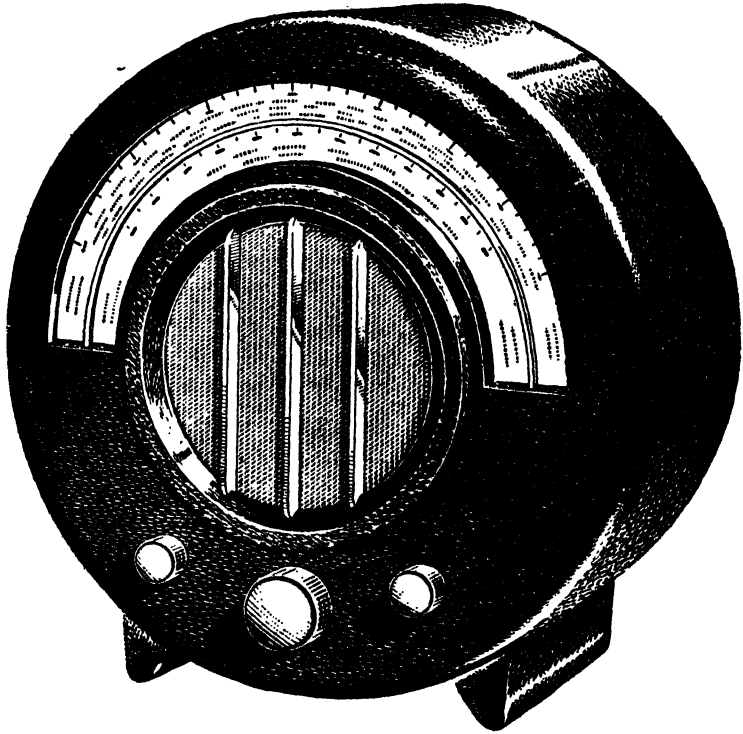
decorative art, there was the work of Eric Ravilious for Wedgwood pottery and Keith Murray's work for the same firm, also his designs in domestic glass for Stevens & Williams, Ltd. There were the decorative treatments carried out for Pilkington Brothers, Ltd. on various forms of glass, by Kenneth Cheesman, Sigmund Politzer and Hector Whistler; the glass patterns designed for Chance Brothers & Co., Ltd. by Paul Nash and R. A. Duncan.

During that twenty-year period many articles passed through fresh phases of development, some continuing an evolution of form that began in past centuries, others finding their origin in new needs, and swiftly shaking off allegiance to prototypes. In Chapter VI the evolution of design in railway rolling stock was examined; much the same process has occurred in other branches of industrial design, beginning with a similar dependence upon prototypes. Here are some examples of progressive development in design which had reached high standards before 1939 and which may indicate the pace of change in public taste.

Two characteristic appliances of our time are the gramophone and the radio receiving set. The gramophone (or phonograph as it was called at first) began as a piece of exposed machinery mounted on a simple base. There was no attempt to disguise its mechanical functions; they were as externally visible as those of an early locomotive—it was mechanism in the raw. The next stage was a general tidying up of the exposed mechanical parts and their partial enclosure in the base, which became a box, while the sound amplifying trumpet was made decorative, not only with colour but by shell-like convolutions, so that it expanded as a flower expands in sunlight. At the next stage the trumpet disappeared; the amplifying apparatus was accommodated inside; a lid concealed the rotating disk of the record, and the gramophone became a cabinet, a piece of furniture and as such susceptible to all the traditional influences which could be pressed into the service of external decoration.

The radio receiving set began in precisely the same manner as the phonograph and the gramophone. At first it was a piece of complicated and rather untidy machinery. The crystal sets of the early 'twenties with their tangle of cables and ear-phones and apparatus, exposed their entrails to the world with the unreticent brutality of a typewriter. Then came technical refinements and new inventions; valves and loud-speakers and all manner of subtleties, and greater compactness was achieved.

The gramophone and the radio set were presently combined and the radio-gramophone as a composite piece of apparatus displayed



This radio set, an Ekco model, is of moulded plastic and was designed by Wells Coates, F.R.I.B.A., R.D.I., and first produced in 1935-6. Here the radio set has shaken off all allegiance to prototypes; it is embellished only by the studs and dials needed for tuning-in and controlling the volume of sound. Like the Aga cooker shown on page 150, it is another example of the tendency of contemporary industrial design to create smooth, continuous surfaces. (This drawing is made from a photograph, and is reproduced by courtesy of E. K. Cole Radio Limited.)

so violent a reaction from the crude mechanical exposures of earlier days that it was sometimes difficult to tell, when all the doors were closed, exactly what this new piece of furniture was. It might borrow its shape from early Stuart or Carolean furniture; an imitation Tudor food hutch might even house the latest mechanical triumph of the twentieth century. Again it might seek a borrowed elegance from the William and Mary period, elevating upon turned or cabriole legs a cabinet that contained all the essential mechanism. But at last there was a rationalising process, and the work of engineers was no longer accommodated in cabinets that were earnestly pretending to be something antique. The radio-gramophone was acknowledged

as a piece of furniture with a function and form of its own. The wireless receiving set as its apparatus became more compact and made fewer claims on space, began to acknowledge its obligations to truth about its function, and in that acknowledgment it could display simplicity and comeliness, allowing the cabinet-maker an opportunity for using decorative veneers.

The ultimate form of the radio receiving set may be a small case of glass and metal and plastics, claiming little space, embellished only by the studs and dials required for tuning in and controlling the volume of sound. Already this stage is foreshadowed by some of the radio cabinets moulded from plastics which show how this problem has been tackled by leading industrial designers, like Misha Black and Wells Coates.

Two examples of development in design extending over three centuries are clocks and artificial lighting appliances. Clocks were in use in Europe as early as the thirteenth century; but they were generally large in scale, designed for churches, and small clocks were rare and costly curiosities. It was not until the middle of the seventeenth century that clocks ceased to be rarities in England. Their form at that period was compact and simple, a small piece of mechanism accommodated upon a bracket that projected from the wall, with weights dangling at the end of chains. These "lantern" or "bird-cage" brass-faced chamber clocks thus had an essential part of their mechanism untidily exposed. The weights still hung down in the next stage of design, when the metalwork was enclosed by a wooden case, and so did the pendulum when that device was introduced. The clock with its oak hood and polished metal face was still a bracket clock, but now the bracket had been incorporated in the clock case; it was no longer a clock standing on a little jutting shelf: the independent shelf had disappeared.

The next advance in clock design provided a covering for the weights and pendulum, a tall wooden structure which supported the clock; thus the long-case or "grandfather" clock arrived, a form susceptible to the influence of current architectural taste, which settled its proportions and moulded details. As the mechanism of clocks improved, it became possible to accommodate it within a relatively small space, and the case, whether of a grandfather or a table clock, was dominated by the dial. Externally clocks might become overloaded with ornate decoration, as indeed they did on the Continent during the eighteenth century, and such offensive and ridiculous forms as miniatures in bronze or plaster of the Venus de Milo, mentioned in Chapter V, with a clock face in the stomach,

appeared in England in the nineteenth century together with gloomy, sepulchral timepieces in black marble, like miniature Greek or Roman temples in deep mourning, adorned by nondescript figures of gilded angels. All such trimmings were shed by cheap, mass-produced clocks, which compressed the works into the smallest possible space, and changed the clock from an article of furniture back to the purely functional mechanical appliance it had been originally. Now the electric clock has disposed of the mechanism, leaving only the dial and hands, for a plug connects them with the source of supply, and the operation of the timepiece is subject to remote control, which checks and adjusts thousands of such clocks hourly. Many of these electrically operated clock-dials are surrounded by useless and empty cases: it may take a long time to lay the ghost of clockwork. With appliances for artificial lighting, the ghost of the candle is just as persistent. In the artificial illumination of rooms design *should* have been consistently influenced by the character of the illumination, as it was in its initial stages when candles were used. The candlestick, the wall sconce and the candelabra were all functionally designed to provide illumination with the maximum of protection from dripping wax. Throughout the seventeenth and eighteenth centuries the form of candelabra was determined by these functional needs. The embellishment of the necessary structure graciously accorded with contemporary fashions. Elaborate and beautiful designs were worked out in various materials—brass, carved, gilded and painted wood—and the crystal chandelier with its lustres and myriad reflections represented the peak of achievement for this type of multiple candle holder.

When a totally different form of lighting was introduced, namely gas, the new power was adapted to forms which closely resembled those used for candles. The gasolier was an adaptation of the chandelier. When electric light began to compete with gas, the electrolier again followed the candle-holding forerunner. The early carbon bulbs would be mounted on porcelain tubes to imitate candles, and even when they were replaced by the more brilliant metallic filament bulbs, this limitation was still imposed. Bulbs of frosted glass were often made in the form of static flames. True these dummy candles allowed antique candelabra to be used; but this elaborate disguise of the new form of lighting was an obtuse rejection of the new freedoms and possibilities it promised. Bulbs were at first exposed, then shaded, and all kinds of decorative and inflammable materials were used for shades; freedom from the danger of fire through contact with the source of light being the first to be appre-

ciated and exploited. Candles and gas-lighting had implanted the idea that the source of light must always be visible, or partly screened: a naked flame or a glowing filament were familiar. So the possibilities of flooding a room with light, cast from concealed troughs upon the surfaces of ceilings and walls, were seldom explored.

Now fluorescent lighting has again changed the character of artificial illumination. Its pipe lines of light, long, glowing glass tubes, may be carried anywhere in a building to shed an undistracting radiance. Can the ghost of the candle continue to haunt homes, factories, offices, inns and hotels if fluorescent lighting is properly used? The taste of the public may ultimately decide this; and as it responds favourably on some occasions to good design, particularly with articles that have a mechanical or semi-mechanical function, the period of disguise in artificial lighting may be coming to an end, as it has come to an end with radio sets and gramophones and various domestic appliances.

The conflict of opinion about the character of public taste and the prospects of improvement has been indicated, and its commercial aspect discussed. The dictatorial highbrow approach to the problem is often just as misleading as the purely commercial approach, even though it is suffused with idealism. "People *ought* to like good design," is the view of the intellectual critic and reformer, who is often honest enough openly to express his sincere convictions in such straightforward terms. But to impose the taste of the few on the many is tyranny; even though it is done in the interests of improved design. In a democracy, people must be educated and persuaded, so their interest may be carried to the point of *observing and comparing before they choose and buy* the things they have to use and live with in their homes. This is a long job: spectacular results are unlikely to be achieved within a lifetime. But reformers are impatient folk; lacking their noble dissatisfaction with things as they are, they would not be reformers. Professor Brogan explained the impatience of the dictatorial type of reformer when he said: "The irritation the administrator or publicist or theorist feels at public pig-headedness is part of the price to be paid for the education of rulers in the necessary democratic art of persuasion."⁹ Possibly that is why commercial advertising has attained such high levels of efficiency in the English-speaking democracies, and the fact that the arts of persuasion have to be practised alike by commercial organisations and politicians suggests that the public has large powers of critical resistance and a vast, comfortable inertia—factors which slow down the pace of change and very naturally irritate earnest reformers.

Attempts to assess public taste or public opinion are sometimes misleading, even though evidence may be collected impartially. The interpretation of such evidence is often tinctured, quite unintentionally, by commercial or political considerations. Occasionally the earnestness of the investigators bemuses their judgment and may falsify their conclusions. Even scientists are not immune from the danger of falling in love with a neat and tidy theory, and they sometimes do so with such intense and communicable conviction that they can write authoritatively on subjects that are not susceptible to scientific measurement or analysis. The chapters that deal with "Art between the Wars" and "Art looks to Science" in Dr. C. H. Waddington's book, *The Scientific Attitude*, seem to be thus generated.¹⁰

Tom Harrison, who founded that remarkable organisation for man-watching known as Mass-Observation, has attempted to examine public taste in relation to design. Some of his findings were condensed in a lecture which was read on his behalf by D. Behrens before the Design and Industries Association in May, 1943.¹¹ It is necessarily a cursory examination, and it sought to identify things that have a wide and general popularity with things which appeal to an exclusive and intellectual minority. In this lecture the "observers" appeared as highbrows, noting with gratification that the "lowbrows" really had the same tastes and ideas as themselves. Their innocent and humourless method is best illustrated by their comments on Tommy Handley's popular radio programme. "Now those of you who have listened to the *Itma* programme will realise what a very intellectual form of entertainment it is. Think of the strange places from which the diver emerges. Is not this pure and unadulterated surrealism carried into the field of radio entertainment? And again, just think of a few of the puns with which *Itma* fairly bristles. To take but one example at random—the ship which was being built, and which thanks to the Italian accent of Mr. So-So, turned out to be not a ship at all but a sheep, complete with bleating. Is this the sort of entertainment which would appeal to the masses, according to the old-fashioned precedents? Clearly it is not. And yet the evidence is there. *Itma* is one of the most popular entertainments which has ever been put on. It is also the radio entertainment demanding the greatest degree of intelligence from the listener."

Such conclusions could only be drawn by people wholly destitute of the sense of humour and with limited knowledge of the popular songs and literature of their own country during the last hundred years. The pun has gone its roaring and boisterous way down the centuries; think of Marryat and Hood and the songs and music-hall

patter, the pages of *Punch*, and the other comic papers—*Pick-me-up*, *Scraps*, *Moonshine*, *Judy* and many more, long dead—that poured out quips just as complicated, far-fetched and nonsensically funny as those produced by that gifted script writer, Ted Kavanagh, for the *Itma* feature. The Mass-Observers' attempt to identify items in this programme with current or outmoded artistic or intellectual ideas—such as the assertion that the diver in *Itma* is a piece of radio surrealism—resembles the attempt of the Turkish lecturer in G. K. Chesterton's *Flying Inn* to prove the Arabic origin of English institutions. "Why, my good friends, the very name of that insidious spirit by which you make strong your drinks is an Arabic word: alcohol. It is obvious, is it not, that this is the Arabic article 'Al' as in Alhambra, as in Algebra; and we need not pause here to pursue its many appearances in connexion with your festive institutions, as in your Allsopp's beer, your Ally Sloper, and your partly joyous institution of the Albert Memorial."

The question posed earlier in this chapter: will the British public always accept with uncritical placidity the Tower Bridge approach to design? remains unanswered.

Is there anything about the present state of industrial art that would suggest an answer?

Industrial art today has opportunities of developing a distinctive character, if it can escape from the limitations imposed upon its practitioners. These limitations are not all imposed by industrialists: they are imposed very often by theories of design, by imagined obligations to honour the barren doctrine of functionalism. After the ornamental excesses of the Victorian and Edwardian periods, we have passed through a phase when designers concentrated upon "fitness for purpose," in order to restore a proper respect for utility. This was followed in the late 'twenties and 'thirties by an exaggeration of such respect, when designers deliberately abstained from all ornament, and asserted their faith in the ancient fallacy that fitness for purpose was an end in itself. That was perhaps a little too easy; and Mr. Roger Fry destroyed it—as it has to be destroyed in each generation—in a Memorandum which formed an appendix to the Gorell Committee's Report on Art and Industry. He said:

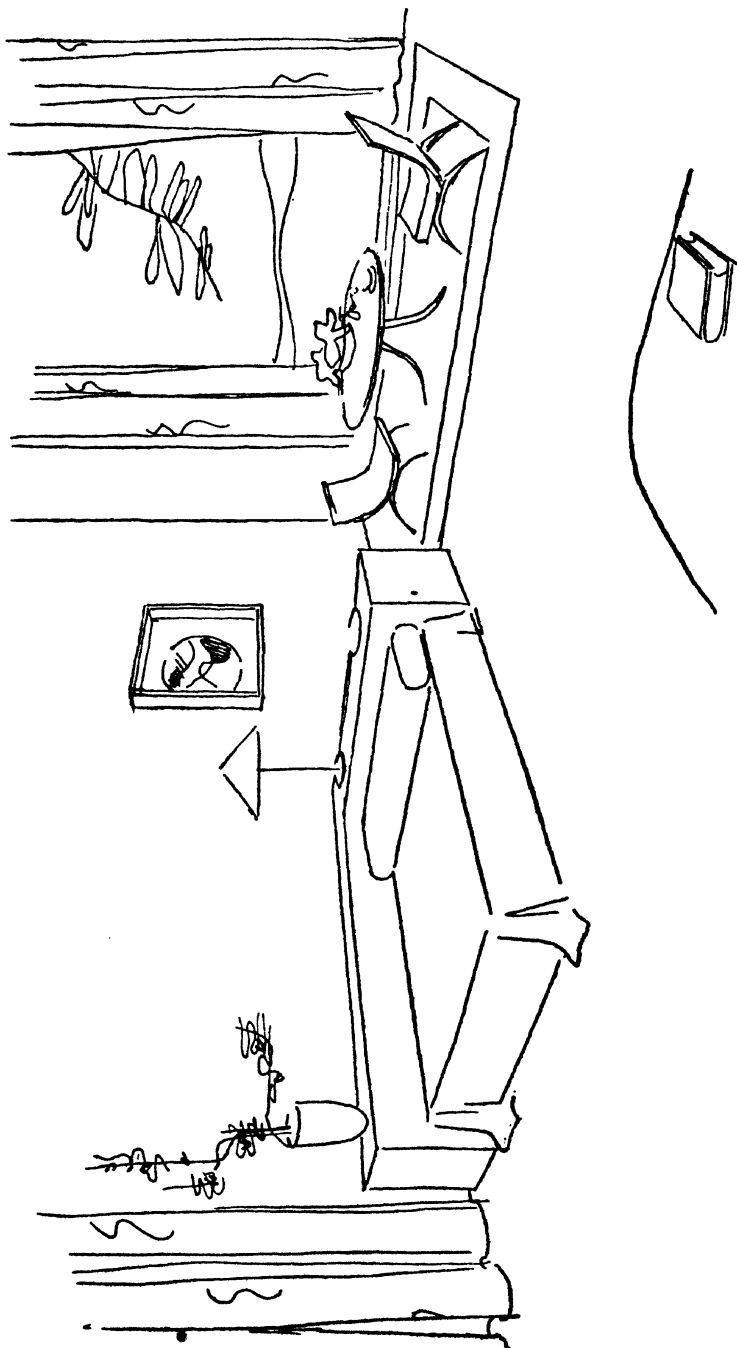
"Though such a theory would at least spare us the horrors of futile decoration it would none the less prevent any real development of artistic design. It is true that the best designs often take the functional purpose of an object as a point of departure, but the aesthetic satisfaction given by a beautiful design is quite distinct from the pleasure of recognising functional adaptation. Good archi-

ecture must always remain distinct from good engineering and this principle holds equally in the design of objects of daily use."¹²

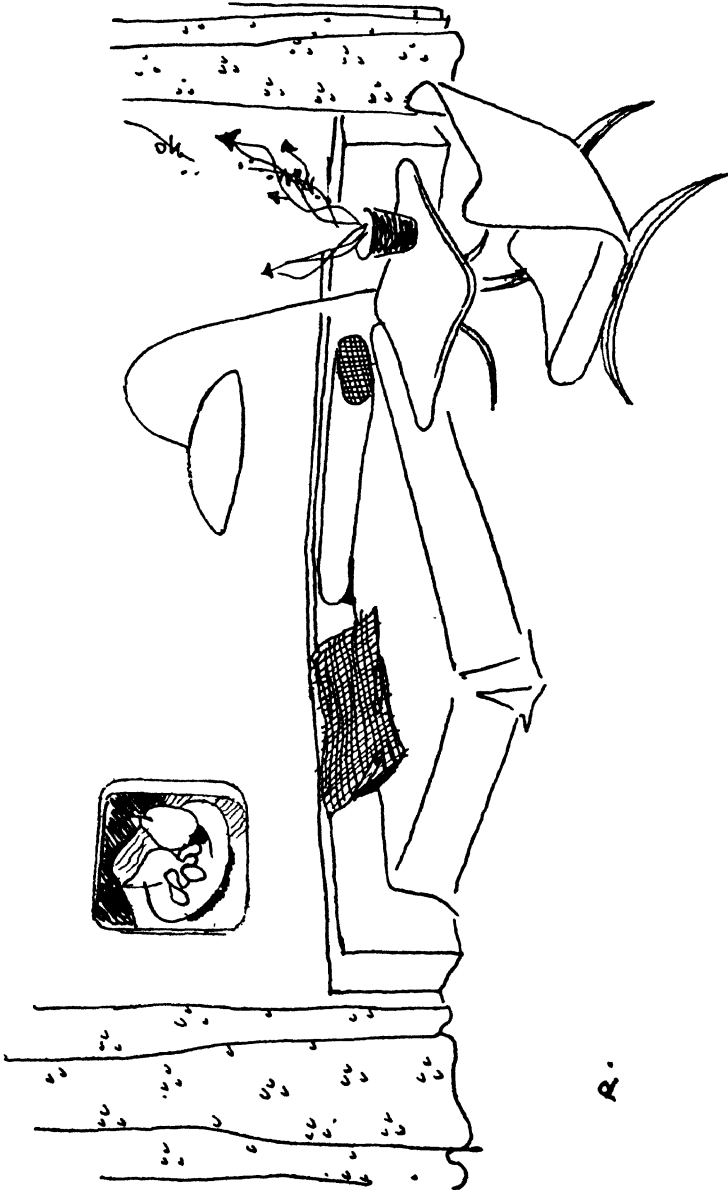
To many designers of limited fertility, the slogan "Fitness for purpose" excused the practice of a crude form of functionalism, unrelieved by concessions to human needs. Various other slogans connected with design, and particularly with architectural design, were circulated to comfort bright young people who wanted to be modish without the hard work entailed by thought. Critics and designers would murmur "out of the ground into the light," or "the house is a machine for living in," and the works of Monsieur le Corbusier promoted an exaggerated respect for industrial architecture, so that some people were prepared to lavish extravagant admiration upon such utilitarian objects as gas-holders and factory chimneys. The real character of the modern movement in design, and the discrimination of its most intelligent and imaginative exponents—industrial designers like Christian Barman, Wells Coates, Brian O'Rorke, R. D. Russell, Grey Wornum—are unobserved by critics who still think that modernism is merely abstinence from decoration. This sort of remark is typical of the reactionary school of criticism: "One does not want to live either in a conservatory, or in rooms which appear to be suggested by the operating rooms of a hospital." Thus Sir Reginald Blomfield in a stimulating attack upon the modern movement called *Modernismus*.¹³ Again, Mr. John de la Valette, in the introduction to *The Studio Year Book of Decorative Art*, 1934, refers to "hospital-cum-factory furniture," and is encouraged by his belief that in 1933 "women have begun to reassert themselves, and to go against the dictates of the solemn kill-joys, the aesthetes, the theoretical designers and, worse than all the lot, the many who write about art." Mr. de la Valette expresses the view that "the reaction against superfluous objects and aimless ornament has gone the full length, until anything falling short of the hygienic standards of a hospital dormitory is looked upon with suspicion."

Even a writer of the intellectual standing of Mr. Aldous Huxley betrays the same misconception about the modern movement in much the same phrases. In one of those richly discursive paragraphs in *Beyond the Mexique Bay*, he says: "For us, today, the highest luxury is a perfect asepsis. The new casino at Monte Carlo Beach could be transformed at a moment's notice into a hospital. . . . The Wagon-lit Company's latest coaches are simply very expensive steel nursing-homes on wheels."

But the period of asepsis is past; the competent designers have left



An interior designed by Michael Rachlis. Compare this with the interior on the opposite page, by the same architect.



Another interior designed by Michael Rachlis, which introduces some decorative patterns in the furnishing fabrics. Both these rooms reflect the desire to create smooth continuous surfaces, which is characteristic of contemporary industrial design; but the designer does not exclude pattern.

it far behind them. But while such critics as Sir Reginald Blomfield, Mr. John de la Valette and Mr. Aldous Huxley were expressing their various reactions to the manifestations of the modern movement, the people in control of British industry were largely unaware that there was such a movement. To them the word modern meant "jazz" or "futuristic" stuff. An illustration of the attitude of mind that existed (and still exists) in many industries that could derive economic advantages by collaborating with designers is to be found in a report, prepared in 1928 and published in 1929, by two of H.M. Inspectors of Schools, to assist the Joint Standing Committee (Industry and Education) of the British Cotton Industry Research Association in discussing the training of designers for printed and woven fabrics. Entitled, *Design and the Cotton Industry*,¹⁴ it surveyed the methods customary in the cotton industry for obtaining fresh designs. It was a revealing example of traditional industrial patronage, and suggested that the ideas about design recorded by Mr. Samuel Sidney in the middle of the nineteenth century were still flourishing in Lancashire between the wars. The Cotton industry, it seemed, was only driven to consider education in design at all when the prosperity of Lancashire began to totter. "Compelled by intensified foreign competition and the consequent loss of markets for plain goods, manufacturers are turning their attention to the production of fancy goods in which design is all-important." A comparable situation in another branch of industry was described by Mr. Sidney, who also mentioned the economic consequences of making "fancy goods" without design. "THE GILT TOY AND MOCK JEWELLERY TRADE, once one of the staple employments of Birmingham artisans, has dwindled away until it now occupies a very insignificant place in the Directory. Bad cheap articles, with neglect of novelty and taste in design, ruined it. In cheap rubbish foreigners can always beat us, but the Birmingham gilt toy men made things 'to sell' until no one would buy."¹⁵

It was stated in *Design and the Cotton Industry* that economic circumstance rendered it "vitally important that effective means shall be found to draw into the service of the industry men and women of trained artistic ability." As this was being done by other industries, "the cotton industry cannot afford to remain indifferent." The report admitted that even if the art schools encouraged students to consider the prospects of the industry, "whatever be the attitude of the authorities of the schools, the well-informed and capable students will, as far as they can, choose that branch of applied art which offers the greatest opportunities of advancement, professional, social

and financial." In the paragraph following this admission we learnt that in the cotton industry "changes, even if they are recognised as improvements, must be based upon current practice, and they will be slow, piece-meal and, usually, imposed by economic forces." The views of the industry on the value of art and the remuneration and status of designers have since changed. At the time of this report £6 a week was considered adequate for first-class designers. After mentioning that particular valuation, the report recorded that: "The supply of finishers and ordinary designers is said to be satisfactory, but really good designers are rare."

The sources of supply for designs for printed and woven fabrics were described in detail, also the manner in which such designs were inspired. Whether art and industry could enjoy their fruitful partnership in that particular field may best be judged by the following quotations from the report:

"Fabric printers obtain their designs from one or more of the following sources: works studios, English commercial studios (chiefly in Manchester), free-lance designers (including, occasionally, art students) and French commercial studios."

"The designs may be either entirely new and the expression of the designer's own originality, or, more often, the result of suggestions made by clients and based upon their opinion of what is likely to sell in the particular market for which they are catering. These opinions are, of course, usually based upon designs which have already proved successful."

"It does not appear to be unfair to say that the designer in a studio is generally looked upon as a person of no great importance."

The British Institute of Industrial Art estimated that only 3 per cent of the designs were bought from free-lance artists. When the free-lance "presents his designs for inspection, the treatment he receives sometimes reflects too crudely the subordinate status of the designer in the studio, and he retires from the effort in disgust."

Incidentally those firms employing free-lance designers "have reaped their reward in the freshness and originality of their products." There were occasional attempts to use a French designer on the spot, but it was found that "if he is transplanted to England and particularly to Manchester he loses his freshness in a short time."

French designs were bought by managers, heads of departments or salesmen who, without any training in design, had "formulated practical standards of taste by long experience in handling fabrics, by critical attention to designs and by close contact with markets."

It was suggested that those buyers objected to innovations. It is almost an English proverb that everything naughty, new and nice comes from France; it is the enduring monument to Colbert's propaganda that we should have such a high opinion of French eminence in art; but it is uncomplimentary to English discernment that there should ever have been "evidence that the free-lance artist is more likely to get his designs placed if he commissions a French agent than if he tries to place them himself." Also "it is said that the French designers have a certain contempt for the English buyers of designs and do not show them their best products. It is difficult to see the reason for this and in Paris it is stated without qualification that the best designs come to the English market."

Manufacturers of woven fabrics got designs from "public designers" (whatever they may be) and from the design rooms of their own mills. The same futile muddling with design was exposed in this branch of the business, and the whole report showed the ignorant contempt in which art was held by many firms engaged in the cotton industry. In the words of the compilers of the report: "one is led to wonder whether the more frequent employment of professional artist designers of high standing in England, and a closer connection with the schools, might not do something to counterpoise the weight of French tradition and psychological aptitude."

The cotton industry has since become alert about design, recognising it as a technical operation of immense significance. But at the time that the report was written, the attitude of the cotton industry was not exceptional. Before the second world war anybody who inspected the weary miles of indifferent rubbish that lined the aisles of the British Industries Fair every year; who examined the fancy goods departments of retail establishments, large and small; who mourned the snail's progress of good design in the trades that are responsible for making the Englishman's home what it usually is—any such conscientious observer was overcome, not only by depression, but by curiosity regarding the reason for this queer stagnation in our industrial life. One reason was that the artist had no status in England.

Original creative design did not greatly interest England before 1939; but it did interest the rest of the world, and as a nation we did little to satisfy that interest. The manufacturer may be able to hold part of the home market by producing articles that are appropriate for the people who make their homes in sham Tudor houses that look like cuckoo-clocks, but unless he can find and exploit large, new barbarian markets abroad, which would find flashy rubbish

acceptable, he will be limited to the home market. And in time even the home market may rebel.

The Tower Bridge approach may at last be rejected by the public; and for the following reasons:

We have, during the next half century, a remarkable opportunity for civilising our commercial machine age. We shall have a new consuming public, living side by side with and differing from the public of the nineteen 'thirties. Men and women with service experience will be making homes of their own; they will have heard about the sort of homes they could have; the sort of homes that industry could provide for them. (The factory-made house, for example, has become a problem of industrial rather than architectural design.) Men and women of this new generation have exchanged views with their Canadian and American comrades, and have heard how much easier life is in North America because of the abundance of well-designed, labour-saving objects in nearly every house, however small, in nearly every apartment, however cheap. In the United States, industry has come to terms with the designer, and the designer has discovered how he can become a real partner in the business of industrial production.

With our new public in prospect, and with education planned far ahead—not in the short life of a Parliamentary session, but education that will reach out four, five or six generations ahead—we could regain, as a nation, all the critical values we have lost during the past century, and our designers could then serve industry as trusted and authoritative technicians.

THE INFLUENCE OF MATERIALS ON DESIGN

BEFORE the first industrial revolution, the materials used by craftsmen had imposed certain definite limitations upon their skill. Much of their time was devoted to overcoming those limitations: for example, the task of shaping wood called for great ingenuity and a large stock of patience and knowledge. English craftsmen always worked with the greatest sympathy for this material; they thoroughly understood it, humoured its peculiarities, and even took advantage of them, turning to account the properties of such hardwoods as oak, using with decorative effect the colour and markings of walnut, and the fruit woods like apple and cherry. It was their practice to work *with* materials, never to force them to serve purposes or to create forms that defied, exaggerated or strained their natural attributes: to do so was not only enormously costly in labour and money, but represented an alien approach for English craftsmen. Perhaps this was a reflection of the democratic spirit in design, resembling government by persuasion. The tyranny of dictatorship was suggested by the way French designers used materials for the making of luxurious furniture in the days of Louis XIV and Louis XV. They seldom studied the nature of the materials used by the craftsmen who had to execute their ideas; instead, they demanded from those experienced and sagacious men miracles of skill, in order to compel materials to perform fantastic tasks for which they were often unsuitable. In England, the technique for using various materials had been continuously improved since the Middle Ages; progress being marked periodically by the introduction of new tools and processes, so that the first industrial revolution, as we have seen in Chapter III, gradually disrupted a period of great accomplishment in the arts and crafts.

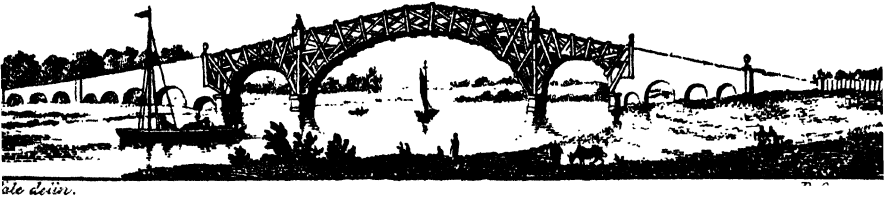
The commonest material and one that had called forth the highest degree of skill in England was wood, for it served many purposes, not only in architecture and the allied arts, but for the building of bridges, vehicles and various forms of machinery, such as looms, spinning wheels, windmills and the supporting framework of some of the early steam pumping engines. The form of design suitable

for wood persisted throughout the first industrial revolution: and some of the early steam locomotives had outer casings of wood on the boiler, suggesting the staves of a barrel. There were many small scale examples of machine design in wood and metal, such domestic appliances as wool winders; and even the early bicycle, the dandy-horse, had wooden wheels. Walter Rose, in *The Village Carpenter*, describes and illustrates a self-propelled four-wheeled vehicle used by his uncle in the mid-nineteenth century, which he called a "forcycle." It was built of wood; the wheels were made with turned ash spokes driven into a wooden hub, with iron tyres on each wheel.¹

The technique of using wood has been changed by mechanical methods, and wood as a material has acquired new properties and has entered into partnership with other substances. Timber is now converted into boards by means of circular saws, band saws or reciprocating saws, which save any amount of hard work for human muscles; and after that it is trimmed into appropriate forms by four-cutters and planers and other woodworking machinery.

The invention of plywood, which is a development of the ancient art of veneering; the use of laminated boards and block boards, and the impregnating of timber with synthetic resins, have vastly enlarged the services of the material and increased opportunities for the designer. Dr. E. Frankland Armstrong, F.R.S., President of the Royal Society of Arts, has expressed the view that timber, one of the oldest materials used by man, is in its contemporary forms one of the newest as a result of the innovations in its treatment introduced by chemists.² Plywood is made by glueing thin sheets of wood together, with the grain running at right angles in adjacent sheets. According to P. Morton Shand, it was first made on a commercial scale in Estonia in the opening years of this century "where it was used in the mass-production of the seats fitted to bent-wood chairs for the Indian market."³ During the eighteen 'eighties a discovery was made in Russia which enabled this new form of wood to become a practical possibility, for it had been found "that a mixture of blood-albumen and casein furnishes a water-resisting cement which lock-joints the surface pores of wood together with a tenacity unapproached by any fish or animal glue."⁴

Laminated boards and block boards differ from plywood, for they have a core composed of vertical slats, and this core is sandwiched between horizontal veneers. Dr. Armstrong in his paper, "Chemistry in the Service of Man," has stated that "The present technique of laminating makes it possible to make at a reasonable cost wood beams, which are larger in size than solid timber, and in suitable



Walton Bridge in the eighteenth century represented one aspect of the technique of designing in wood, which had been developed and perfected in the ten centuries that preceded the first industrial revolution.

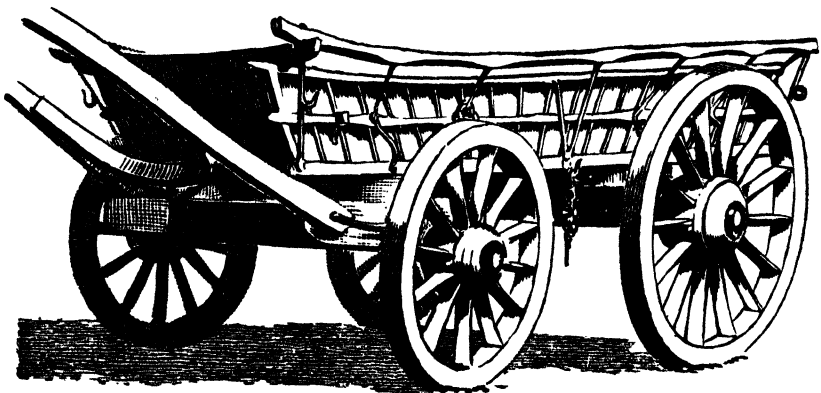
shapes for laminating lends itself to long, narrow, deep structural timbers which, being thin, can easily be bent fairly sharply so that curved arched members suitable for bridge construction are easily fabricated.”⁵

These new developments of a traditional material have great significance for industrial designers. Plywood impregnated with synthetic resin has established an alliance between plastics and timber which allows what are virtually new materials with new and sometimes astonishing properties to be created. It is one of the characteristics of the second industrial revolution, which is based on the use of electric power and the introduction of chemically produced substances like plastics and new light alloys of various kinds, that it has a rejuvenating effect upon traditional materials like wood and iron. Stainless steel is one example; the contemporary improvements in the properties and surface treatments of cast iron affords another. Writing of the finishes now available for this material, Mr. Derek Bridgwater, B.Arch., F.R.I.B.A., the architectural consultant to the British Cast Iron Research Association, has said: “Today the architect or industrial designer can and does choose from an enormous field of finishes in order to obtain not only a non-corrosive finish, but one of almost any texture or colour that he desires. The Victorian taste for enrichment, unnecessary and inappropriate ornament, knobs and bits and pieces has nearly gone, and with it the Victorian inability to produce any finish to cast iron other than a surface requiring interminable black-leading. Many people fail to realise this and are surprised when they learn that their clean, gleaming ‘Aga’ cooker, their pastel-shade bath, their cooking and table ware, the bright metallic panels on many buildings, are still

made of the material that they have learnt, through an unfortunate period of decadent industrial design, to despise; a material, it is true, that has advanced metallurgically beyond all knowledge and which can now, through these new surfaces and finishes, fit so well into contemporary architecture.”⁶

One instance of the changes wrought by the programme of research undertaken by the industry may be given, namely the spraying of cast iron surfaces with other metals. Mr. Bridgwater tells us that by means of a special pistol any solid object may be coated with any of the common metals and alloys. “Lead, zinc, tin, aluminium, copper, iron, nickel, brass, bronze, etc., can be deposited in this way on a casting and to any thickness desired from about 0.002 inches upwards. The original casting must be slightly rough to form some adhesion, as no alloying action takes place. This system has come much to the fore of recent years, but still has enormous possibilities. It has been used in an interesting way to deposit aluminium as a resistant to heat corrosion on fire grate bars and fire parts generally. Zinc is used as a deposit on cast iron air bricks, ventilators and gratings.

“The more decorative spray finishes can be used very effectively on window aprons, sculptured panels, doors and such large areas, but one of the chief assets of the system does not seem as yet to have been fully considered. The modern pistols for spraying are light and highly efficient, and the whole plant can be taken to a building and the metal work sprayed in situ when erection or assembly has been completed.”⁷



A Sussex farm wagon which illustrates another aspect of the technique of designing in wood. (From *The Story of the Wheel*, by Geoffrey Boumphrey. Reproduced by courtesy of A. and C. Black, Ltd.)

An example of contemporary improvement in the use of vitreous enamel on cast iron is provided by some cooking ware in this material. The metal whereon a coating of vitreous enamel is fused must be of a special enamelling quality, produced to specification so that its composition accords with the enamel which is to be applied. The vitreous enamel is a coloured, glass-like substance, which is fused to the iron at dull red heat. It gives a hard, durable surface, difficult to scratch or chip, unaffected by the heat of cooking operations, resistant to stains, and incapable of being dissolved by cooking fluids. Such finishes have enabled designers to use cast iron in new and agreeable ways, and a re-examination of the possibilities of this material after its extensive and prolonged misuse during the nineteenth century may at last establish the partnership between ironfounders and designers, which had seemed so likely in the days when cast iron was engaging the attention of men like Telford and John Nash. W. R. Lethaby, with his remarkable and sympathetic knowledge of all the materials that could serve the designer, realised some twenty years ago that a fine material was being unjustly neglected. Writing in a series of articles which appeared in the *Builder* during October, November and December, 1926, he said—and his words recalled the strictures of Pugin—“Any attempt to reform and perfect the use of cast iron in modern building would have to be done with great reticence and modesty in a straightforward and functional way, as elegant engineering rather than ornamental designs in sham styles.”

Lethaby realised what very few people do realise, that an immense amount of the everyday things that we accept as our background are made of cast iron. In drawing attention to what has been called “street furniture” he said: “Our pillar post-boxes are efficient and inoffensive, we have become accustomed to them, and they are without much ‘design’ nonsense; their colour certainly helps them. Done in due course and without any pretence, they are one of the best triumphs of nineteenth-century art: many of us have quite an affection for them. There have been rumours from time to time that they were to be ‘improved’ by the imposition of style design, but fortunately it has not yet happened.”

Sir Giles Gilbert Scott’s telephone kiosks, designed in cast iron for the G.P.O., were not then in general use; for they certainly fulfil Lethaby’s desire for “elegant engineering.” When contemporary designers study the properties, and incidentally discover the array of new finishes, that are available in cast iron today, they forget their pre-conceived notions of the material.

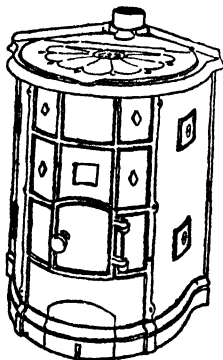
Industries which produce materials that are used by skilled and critical designers have an incentive to embark upon innovations. Experiments by manufacturers in such industries will not be turned down by a repressive distributor, blind in his belief that "he knows what the public wants." Perhaps manufacturers of building materials are given the greatest opportunity for experiment because a proportion of their products is used by trained and educated designers—by members of the only profession that is trained to design, the architectural profession.

The manufacture of glass illustrates, perhaps more lucidly than almost any other industry, the effect of imagination in alliance with research upon the nature of a product. In the making of structural and decorative glass there is in this country a technical fecundity that has changed the whole character of glass as a material for building. This inventiveness is not sporadic; it is continuous, and it is cautious. In this industry designers are often present at the councils of manufacturers. There are working partnerships between designers and other technicians and some of the great British glass-makers have demonstrated the practical value of such collaboration.

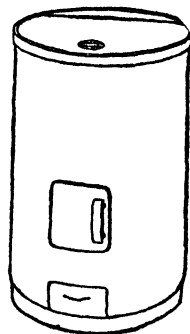
Of most British manufacturers it may be said that they will never release for consumption any product that is still in its experimental stage. Their technical integrity, if it may be put that way, is unshakeable. The revolutionary types of glass that have appeared during the last thirty years have never been casually released.

Structural glass has developed so many surprising qualities that it can never again be regarded merely as a window filler. The opportunities for experimenting with new techniques of design, in which the changed character of contemporary glass could be shown, are limited by what may be called the window complex. Our chief traditional precedents for the use of glass are windows of limited size. We are apt to regard glass as a substance for a set and particular purpose, for the admission of light in association with materials that will guard its natural fragility, such as wooden or metal glazing bars.

Technically, glass has outgrown many of its traditional limitations. Reinforced glass is made, with wire-netting buried in its core, a material with new powers of resistance, something outside the window tradition, and when it acquired the refinement of a square mesh with the intersections of the wire welded, it became a reinforced glass that was intrinsically decorative. This is one rather obvious example of emancipation from the hole-in-the-wall stage. Reinforced glass now comes into the category of materials from which the wall itself can be constructed. It is also an industrial contribution to the



Two examples which show different approaches to the problem of designing a solid fuel boiler. To the left is a pre-1939 model in cast iron: to the right is a contemporary design by Grey Wornum, F.R.I.B.A., in enamelled cast iron. Both are produced by the Carron Company Limited of Falkirk.



possibilities of architectural design, which, like the invention of lifts and reinforced concrete, may help to change the structural character of architecture. Toughened glass brings about a complete reversal of all conventional and accepted notions of what can and cannot be done with glass. This is plate-glass, subjected after manufacture to a toughening process, so that it will bend beneath a weight until the weight is increased beyond the supporting power of the glass, then it disintegrates and breaks up into powdery crystals. This glass can bend and twist under pressure, and it has great heat-resisting powers. Combinations of layers of glass with very thin layers of transparent plastics provide another form of particularly strong glass. This laminated glass when it is built up with many layers is bullet resisting, and is used in tanks and aeroplanes.⁸

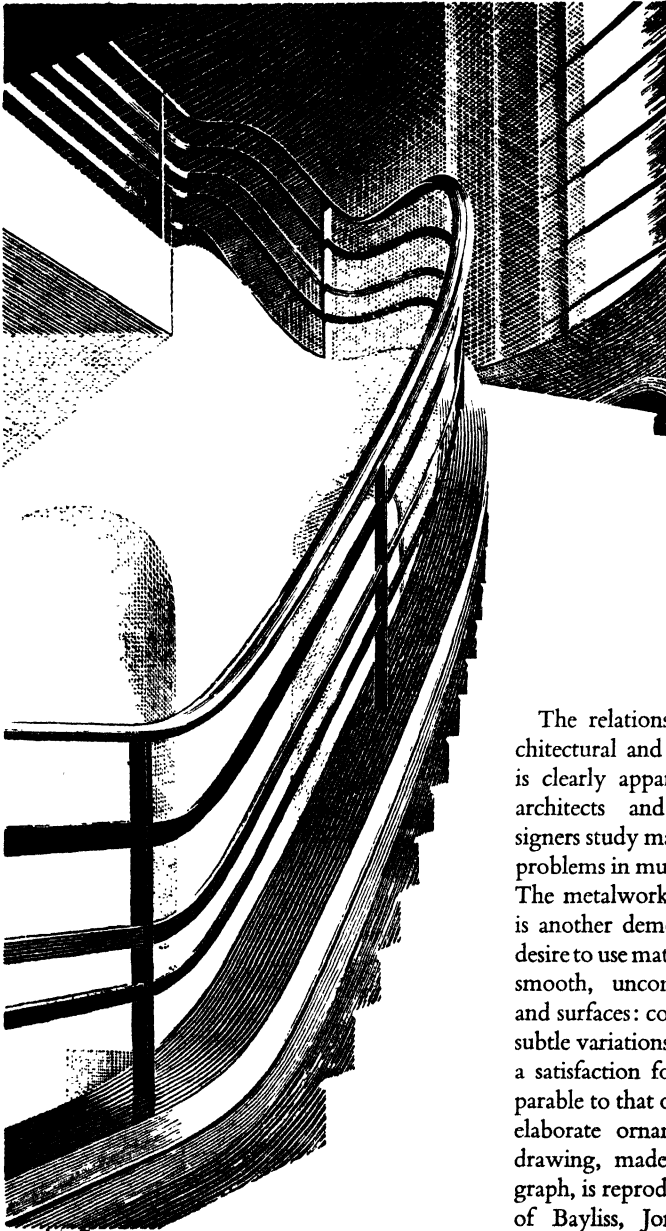
All this prolific inventiveness, sustained and encouraged by programmes of research in different industries, has exerted a considerable influence on industrial design, though not quite so revolutionary as the nature of the changes in the three materials mentioned—wood, cast iron and glass—might have suggested. Nearly always we find the prototype and the habitual, familiar outlook upon a problem of design, retarding progress. Only on very rare occasions are designers allowed to explore without hindrance exactly what a material could do in solving a large or small scale problem of design, and very often this opportunity is limited to paper or to the insubstantial and transitory life of an exhibition stand or pavilion. Three notable occasions of this kind were provided by a large firm of glass manufacturers, Pilkington Brothers, Ltd. of St. Helens, Lancashire; the first occurring when the Crystal Palace was destroyed by fire in 1936. These manufacturers invited three architects to re-design the Crystal Palace, taking account of the great technical advances

in glass making and structural engineering that had occurred since Paxton's design had been prepared. Three imaginative and wholly different designs were produced by Oliver Bernard, Maxwell Fry and Raymond McGrath; Mr. Bernard arriving at a solution which was in line with the traditional structural form of great glass houses, while Mr. Fry and Mr. McGrath were inventive and revolutionary.

In 1937, Kenneth Cheesman designed a travelling exhibition for Pilkington Brothers, consisting of two converted saloon railway coaches; and externally and within these coaches showed the new technical and decorative possibilities of glass. This "Glass Age Exhibition Train" toured the country as part of a scheme of educational propaganda in the use of glass.

The third occasion was the formation of "A Glass Age" town-planning committee, when six architects were invited to re-design certain areas of London and other cities, using the full technical advantages which modern glass could confer upon buildings. The results were remarkable. Addressing their attention to the problem of rebuilding the areas selected, those architects disclosed some of the possibilities that await creative minds when they are released from limitations and allowed to use all the technical knowledge now available for building. These ideas, set down by imaginative designers on paper, illustrate what might happen not only to architecture, but in other departments of design, if we could use with unhampered imagination the technical gifts of our own century. Few modern buildings in Britain are thus inspired; but outstanding among them are the Peter Jones shop in Sloane Square, London, designed by Slater and Moberly associated with William Crabtree and Sir Charles Reilly; the *Daily Express* building in Manchester and the Pioneer Health Centre at Peckham by Sir Owen Williams; stations on the London Underground system, like Arnos Grove, by Charles Holden, and the London Gliding Club at Dunstable, by Christopher Nicholson.

Throughout this book the relationship between architectural and industrial design has been made clear; and the influence of materials on both branches of design is profound. The intensive study of materials may cramp an unimaginative designer; they may dictate ideas instead of stimulating them; but such study can only empower a gifted designer to create with new vision. The influence of materials upon architectural design and construction has been examined with scholarly penetration by Mr. M. Hartland Thomas, F.R.I.B.A., in a paper given under the auspices of the Architectural Science Board



The relationship between architectural and industrial design is clearly apparent to-day, and architects and industrial designers study materials and tackle problems in much the same way. The metalwork on this staircase is another demonstration of the desire to use materials for creating smooth, uncomplicated shapes and surfaces: colour, texture and subtle variations of form provide a satisfaction for the eye, comparable to that once furnished by elaborate ornamentation. (This drawing, made from a photograph, is reproduced by courtesy of Bayliss, Jones and Bayliss Limited.)

before the Royal Institute of British Architects, early in 1944. With the author's permission, a considerable proportion of this paper is reproduced in the Appendix (pages 235 to 245).

The way the architect considers new materials and his critical avoidance of pre-conceived ideas about their use—which are generally, as Mr. Hartland Thomas says, “carry-overs” from techniques established for handling traditional materials—are identical with the practice of the industrial designer. Like the architect, his judgment about materials must be unbiassed; like the architect he must have the will power to think out afresh, in contemporary terms, problems that were solved in the past with other materials. The gifts of the second industrial revolution can make it much harder for a designer to achieve such creative independence. “Every designer who has made the attempt to discard habitual forms and to solve a problem from the logic of the situation alone, knows well how easily his pencil runs along the well-worn lines,” says Mr. Hartland Thomas. “That is the easy way; and, unfortunately, it is made still easier by the resources of modern techniques. There is always a material or a technique available to make a passable construction out of an ill-conceived design.” (Appendix II, page 239.) Some of the new materials of the second industrial revolution make it fatally easy to conceal shoddy thinking or bankrupt imagination; they are easy to misuse, and some of them have masqueraded as substitutes.

The materials characteristic of the first industrial revolution were not so important as the mechanical methods introduced for handling materials old and new; those methods and the capacity for infinite repetition and complexity of form which they conferred, led designers—or people who called themselves designers—into an ornamental maze from which they never escaped. Manufacturers, distributors and consumers worked, lived and died in that petrified jungle. “The easy contempt we feel for iron is the direct result of our unworthy treatment of it,” said W. R. Lethaby at the beginning of the 'nineties.⁹ It would not be difficult to mishandle the typical materials of the second industrial revolution, plastics and light alloys, so that in time we despised them as cast iron was despised fifty years ago. Mr. Hartland Thomas has said, when writing of this particular material: “Cast iron was the fashionable material for the Victorians, just as aluminium, in the age of the aeroplane, is today. But these fashions in materials are rather absurd. Modern design owes little or nothing to discoveries of new material, nor even much to new technique. It is substantially a mental reorientation, intellectual and emotional.”¹⁰

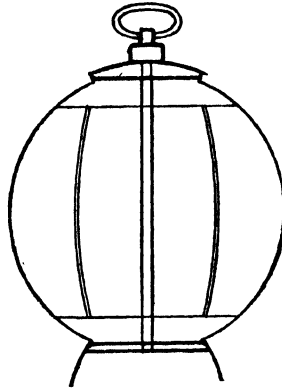
INDUSTRIAL ART EXPLAINED

A portable electric fire designed by Christian Barman, F.R.I.B.A. This is a radiant fire, and the high reflectivity of the principal material is essential: aluminium will reflect up to 85 per cent of average radiation—only pure silver will do more. (These drawings are reproduced by courtesy of Aluminium Union Limited.)



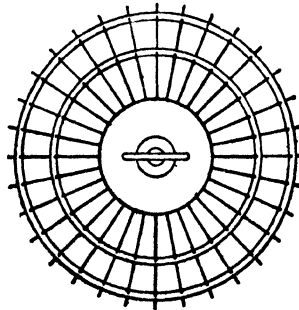
ELEVATION

The basket is built up from vertical and horizontal rings. The vertical rings are of heavy gauge aluminium wire. The horizontal rings are flat sections cut from sheet metal.



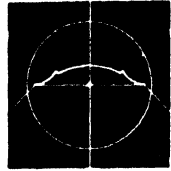
SECTION

The heat element is a rod placed vertically in the centre of the basket. The polished aluminium reflector is concave in the middle, convex at the sides.

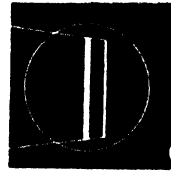


PLAN

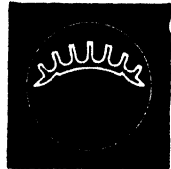
The rods and flat rings are of anodised aluminium of contrasting colours. The ring-shaped handle at the top is of plastic.



The heat beam from the reflector has a wide lateral spread.



In the vertical plane the beam is more highly concentrated.



The air in the room is heated by an arrangement of convective fins.

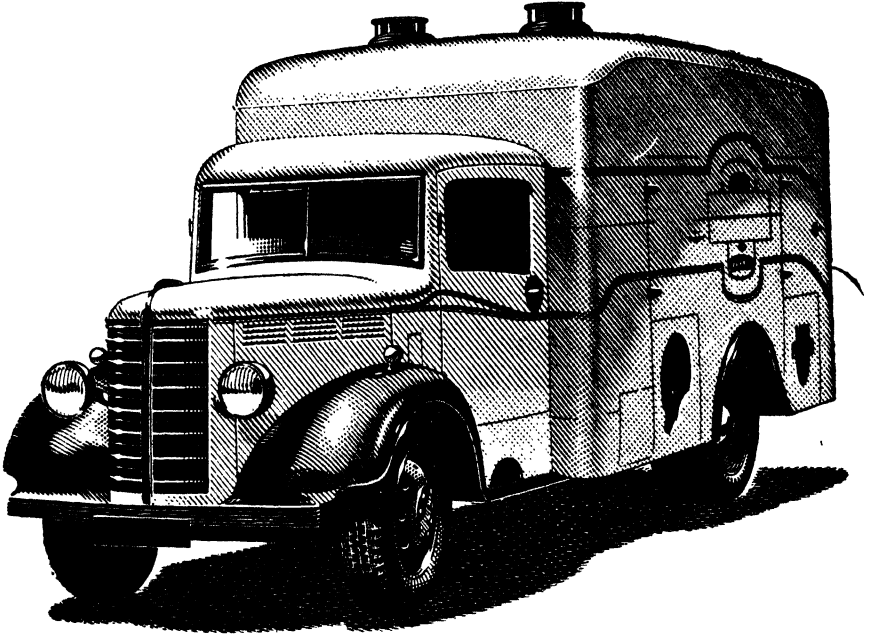
Mr. Hartland Thomas writes not only with the authority of a progressive architect and a knowledge of industrial design, but as an active participator in the work of the Modern Architectural Research Group, of which he is the secretary. Known as the MARS Group, this body was founded in 1934 by one of the leading British industrial designers, Wells Coates, F.R.I.B.A., R.D.I., as an affiliated body of C.I.A.M. (Congrès International de l'Architecture Moderne). Mr. Hartland Thomas rightly condemns fashions in materials; but he unduly minimises the influence of new materials on design. As a result of experimental research work in design with particular relation to a material, such as aluminium, new forms may emerge, which are directly inspired by the special properties of the material. An example of such design research work may be given: it is condensed from *The Missing Technician*, and is specifically concerned with aluminium and its alloys. These materials are ductile and easily and economically cast and fabricated, their outstanding characteristics being high strength to weight ratio and good resistance to corrosion. A few years ago various industrial designers were invited by Aluminium Union Limited to select a problem which could be solved with aluminium and to produce some experimental designs. One of these was by Mr. Christian Barman, F.R.I.B.A. Working in consultation with metallurgical specialists, he designed a portable electric fire, choosing this subject because the material had a sequence of properties which permitted departure from the methods and forms hitherto accepted for electrical heating appliances. Ignoring prototypes, Mr. Barman aimed to design a portable fire which would never be in the way, which could be set down anywhere and overturned without danger. He produced a featherweight spherical cage or basket, formed by curved vertical and horizontal bars of anodised aluminium in contrasting colours, with a base of spun sheet aluminium, and a ring-shaped handle of transparent plastic. The heat element was a rod placed vertically in the centre of the basket, and this basket could be rolled about the floor and nothing that came into contact with it was ever in danger of catching fire.¹¹

Here was an original form, derived from studying a material; no part of a process of evolution from a prototype, no "sport" generated in the course of development, distinctive only by reason of its singularity; but a product of design research work by a talented designer. Now although far-sighted commercial and industrial organisations may invite designers to explore the possibilities of using the materials they produce or fabricate, this becomes for the designer

a specific research exercise: it does not call upon his full powers of selective judgment, and in performing such an exercise his critical discrimination about the relative merits of various materials, old and new, is temporarily in abeyance. The consumer of commodities may suffer, if the primary aim of production is to provide an outlet for a particular material; so that the object is not the best and most economical design using the most appropriate materials, but the "all steel," "all plastic" or "all aluminium" thimble or lawn-mower, or factory-made house. This totalitarian approach to design in terms of material robs the product not only of a substantial part of the designer's knowledge and skill, but of the benefit it might secure from a combination of materials, specified solely because of their efficiency and economy.

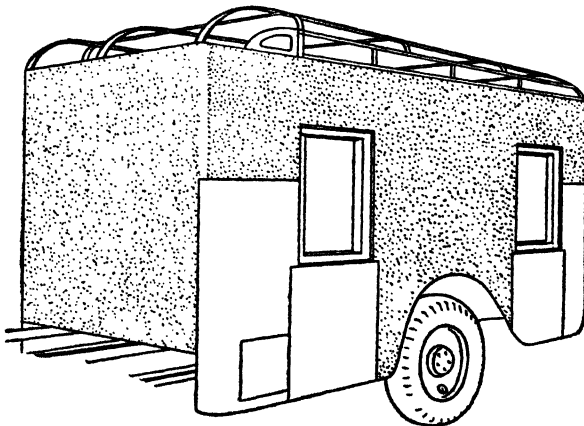
It is clear that materials like aluminium and its alloys must affect the way a designer approaches a familiar problem; and an instance of the way they enlarge his powers is afforded by one of the first refrigerator vans to be built almost wholly of aluminium or aluminium alloy in this country. This van was probably the first all-metal construction unit of its type. The tare weight of the body was 25 per cent less than if timber had been used. The unit was built up with aluminium-alloy angle and T-section extrusions and sheet. The walls, roof and floor of the cab were of cavity construction, consisting of double skins of aluminium sheet, insulated with "Onazote" expanding rubber and "Eutectic" refrigerating units. The framework was also of aluminium alloy. The van had a Bedford two ton chassis with heavy duty tyres.

Such designs not only solve specialised technical problems, but suggest new forms and possibilities for vehicles. The strength to weight ratio of aluminium allows a great increase in the pay-load of vehicles, ships and aeroplanes. Such economic facts must in time affect the design of everything that carries passengers or freight; but their significance is tardily recognised. As long ago as 1910, the Lancashire and Yorkshire Railway began to use pure aluminium sheet for coach construction, and was the first railway in the world to do so; but comparatively little use has since been made of these materials. That fact was mentioned in a paper on "Light Alloys in Post-War Britain," read before the Royal Society of Arts in February, 1944, by Mr. E. C. Goldsworthy, who also said: "The notable exceptions pre-war were sliding doors and window-frames on underground and electric rolling-stock and a certain amount of panelling and internal fittings, whilst successful applications had been made with steam locomotive connecting-rods. In the United States and on the Continent, these



A refrigerator van built for the Midland Counties Dairies by S. T. Abbotts and Company, Limited, of Walsall. It is an all-metal construction unit, the metal being mostly aluminium or aluminium alloy. (These drawings are reproduced by courtesy of the Northern Aluminium Company Limited.)

Below the body is shown partly finished. It is double skinned in aluminium sheet with an internal layer of rubber insulation.



materials have been used for the construction of coaches forming complete trains and for a large number of normal traffic coaches in addition to the various fittings. The increasing demand for comfort is constantly adding to the weight of trains and thus, together with higher speeds, to the power required. The costs of running are further augmented by the increased wear on tracks. Light alloys should materially assist the railway engineer to overcome these problems, but no large turnover to light alloys can be expected until there has been a substantial period of research and practical development."¹²

Road vehicles could be larger and lighter, more comfortable and less costly to run; but there are many restrictions imposed on designers of vehicles, and the benefits of the second industrial revolution are often withheld by officials who are still thinking of the materials and methods common to the first, their minds still moving at the pace of the horse and cart age. This repressive obscurantism was openly denounced by the public relations committee of the British Omnibus Companies, in an advertisement published in *The Times* on October 7th, 1944. Under the displayed headline of "7½ to 8" the advertisement read as follows:

"For 40 years bus operators have been unable to give you as wide a seat as they wished, because the Government has forbidden them to run vehicles exceeding 7½ feet in width.

"The omnibus industry is urging the Government to allow a width of 8 feet, as in the U.S.A. and in the Dominions and in nearly every other country in the world.

"This is being done in your interests, so that you may travel in greater comfort."

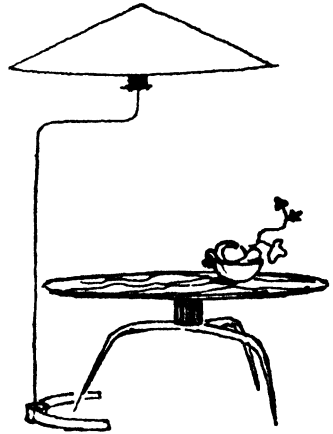
For years London's buses were not allowed to have covered upper decks, because obsolete regulations were still in force. After the first world war, the experiments of the London General Omnibus Company in the form of motor buses exemplified the most remarkable progress in design. The old "B" type bus was replaced by the "K" type in the early nineteen 'twenties, with greater seating capacity, and this was followed by the "NS" type. But these improved types still had open upper decks and solid tyres, although it was not only technically possible but highly desirable in the interests of the public to have covered tops and pneumatic tyres. What is called by courtesy the "official mind" tends to remain inert and unresponsive, until the weight of public opinion and the achievements of private enterprise together threaten the ultimate reputation, advancement and settled career of the particular official or group of officials who are, like

obstructive directors in an old-fashioned, unprogressive business, maintaining their ease and nourishing their dignity by opposing change. Of such is the kingdom of Bumble.

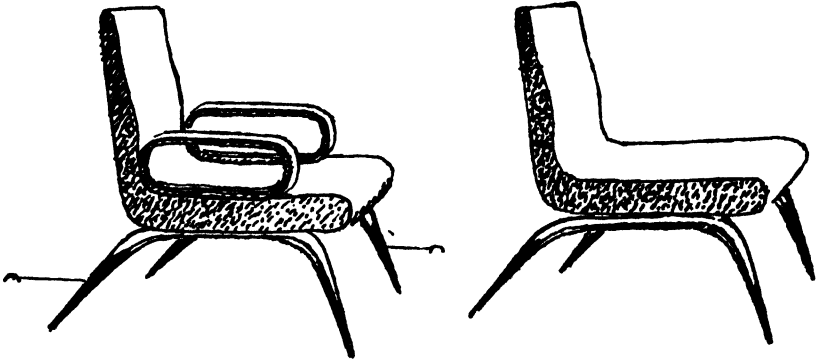
The second industrial revolution with the impetus it has received from scientific and industrial research in the second world war will irresistibly change the production and design of the things we see and use and buy, whether they are buildings, ships, trains, buses, saucepans, safety-razors, cameras, gas, electric and heat-storage cooking appliances, radio sets, bicycles—the list could be continued for pages. Everything mentioned could respond to the challenge of change. Take bicycles as an illustration: we are a long way from the wooden “dandy-horse” on which the rider swung himself along by paddling his feet on the ground—there were no pedals; but there is a lighter and altogether more convenient bicycle just round the next corner of industrial production. At least, Mr. E. C. Goldsworthy in the paper on light alloys already quoted has told us that “A few bicycles have been made almost entirely of light alloys but they have been expensive, partly owing to the high cost of materials but to a greater degree to the higher cost of fabrication. Simpler methods of fabrication are well within the bounds of practical realisation and with lower alloy costs the cyclist could look forward to a light-weight, corrosion-resistant and even colour-anodised bicycle at a reasonable price.”¹³

It has been said that some of the new materials of the second industrial revolution have masqueraded as substitutes, and this applies particularly to those chemically produced substances, called plastics, which are capable of being moulded under heat and pressure. The impact of these materials upon the ideas of manufacturers and industrial designers has already produced remarkable results; some wholly admirable, some trivial and ridiculous. Dr. Frankland Armstrong has suggested that they form a fifth class to those traditional materials, metal, wood, glass and ceramics.¹⁴ The public interest in plastics aroused by the exhibition of British Art in Industry at Burlington House in 1935 has been mentioned in Chapter VIII. The plastics section of that exhibition was designed by Mr. Grey Wornum, F.R.I.B.A., and the exhibit which magnetised attention was a piece of transparent material, labelled “Resin M.” It was transparent, colourless, and without the glitter and sparkle associated with glass. Transparency has an old and wide appeal; it suggests the mystery and magic of fairy tales and the fabulous achievements of djinns. No oriental monarch, no Roman emperor, no Victorian millionaire in Britain or America, could command the forms,

A lamp and table designed by Michael Rachlis, with the base of the lamp shaped to allow it to be drawn close to the table leg. Anodized aluminium is suggested for the lamp and for the table legs, and for the top of the latter, either Burma teak or an appropriate plastic. (These designs are the property of Michael Rachlis.)



Two chairs designed with frames of aluminium of channel section, with an anodised finish. The upholstery is of sponge rubber, or Resilitex, or hair in rubber. They should be compared with the designs in plywood shown in colour on Plate 1. (These designs are the property of the designer, Michael Rachlis.)



colours, textures and infinitely varied properties that are now provided for universal consumption by the plastics family. At first, producers seemed afraid of fully acknowledging those properties; and plastics were disguised to imitate other and more familiar materials: it was their substitute phase, and although they are now beginning to be recognised as materials in their own right, possessing an astonishing versatility, they are still often used without full appreciation of their capacity for changing fundamentally the character of design in many fields.

There is a danger that the increasing use of plastics for industrial

production may encourage intemperance in decoration, because plastics by their nature could facilitate an ornamental exuberance comparable to that which afflicted cast iron in the mid-nineteenth century, when the "unnecessary and inappropriate ornament, knobs and bits and pieces" to which Mr. Derek Bridgwater has referred, encrusted the surface of a fine material. This may happen unless trained industrial designers are actively collaborating in the production of plastic articles; but the danger of misuse, and a consequent proliferation of vulgar and meaningless ornament, resides in the ease with which various plastics may be fabricated. Sir William Bragg, in his Presidential address to the British Association, in 1928, said that "Mass production is in its way splendid, ministering to the necessities and conveniences of many who must otherwise have gone without. But if it is brought to such a pitch that its processes call for little intelligence in their working, then cheap people of little intelligence will be found, in the end, to be in charge."¹⁵

This could occur only if the trained imagination of the industrial designer is omitted from industrial production. The absence of the designer would not only encourage an almost Victorian orgy of ornamentation; industry might altogether miss the opportunity of using the power of plastics for changing the character of design when old problems are tackled. With furniture, for instance, the first reaction of some manufacturers has been to use plastics, either to imitate wood, or to give a novel air of "super-luxury" to forms appropriate only to wood, by reproducing them in a transparent plastic. Chairs that were first evolved in Queen Anne or early Georgian workshops completely lose their character when they are made of a transparent material; they become phantoms, their lines devoid of significance, like X-ray photographs pretending to be portraits. In *Plastics and Industrial Design*, furniture design has been used to illustrate the way plastics might be considered by the industrial designer. "The reaction of the industrial designer to the manifold gifts of the plastics family, is first to discover how stresses and strains, tensions and weights are affected by the materials; what limitations on shape and size are imposed by the various fabricating methods; whether surfaces are resistant to wear and tear and what upkeep, if any, they require. Equipped with such knowledge, he tackles with an open mind the problem of designing, say a chair. He only has to accommodate the contours of the human frame, and although the posture adopted by most Europeans when they are seated has changed slightly during the last century, we are still vertebrates, even though we no longer care

to sit bolt upright, as our great-grand-fathers did, and lounge a few inches nearer the floor than they would have thought consistent either with dignity or decency. Since the early sixteenth century, chairs in England have been supported by legs; before that they were boxes with a high back and solid arms rising above the top of the box. Woodworkers learned how to economise in their material, and to trust its strength in new ways, so four legs, linked and braced by an underframe, eventually supported the chair seat. Then the underframe was eliminated, and the legs were tapered. For a couple of centuries a progressive refinement of design gave increasing elegance to the chair; then the slimming process stopped, and throughout the Victorian period the chair grew bloated and sank down to the floor; its legs bulged and thickened, its swollen feet were shod with castors. Now, the industrial designer has the problem of making a comfortable seat with 'limitless control of material.' The result may be a two-piece chair; a back and seat in one piece, and a curved underframe in one piece to support it."¹⁶

This suggests that plastics can simplify traditional problems of design. They can certainly lead designers away from prototypes, and when they have fully emerged from the substitute phase and are used in combination with other materials, we may approach a period in which industrial art will be liberated, not only from the tyranny of prototypes, but from the austerity that some admirers and practitioners of the "modern movement in design" seem to regard as desirable and inescapable. It is true that the second industrial revolution has hitherto tended to encourage the use of plain surfaces and sleek, uncomplicated forms, but it has also restored an appreciation of texture and colour which had for many generations been obscured by the study and practice of "applied art." An example of the inherent decorative possibilities of contemporary materials is provided by some chairs designed by Michael Rachlis: they have plywood frames, veneered and polished or cellulosed, with the front and back legs connected by plywood tubes, and upholstery of sponge rubber or Resilitex, or hair in rubber. (See page 182 also Plate 1.) Chairs of bent plywood, such as those designed by the Finnish architect, Aalvar Aalto, also depend upon texture and colour for their decorative quality.

Plastics, light alloys, plywood, steel tubing, glass, rubber, composition boards, foil, all kinds and varieties of paper, were being used inventively and occasionally with great originality, before 1939; and industrial art may be enriched not only by an array of new materials, but by partnerships between materials. As a result of war production,

some new partnerships have been made. For instance, it is now possible to weld aluminium directly to glass. Combinations of plastics and light alloys have been tried out and found practical in use; plastic sheets and plywood have been cemented together; and such partnerships between old and new materials, and the improvements made in the character of many traditional materials, increase the designer's control over the form, colour, weight and character of the things he designs. His responsibility for hard thinking is also increased, so he may consciously reject the easy way of using new materials and techniques, and resist the temptation to imitate or adapt an old idea, when some new thing could be created, whose form reflected the scientific and industrial genius of the twentieth century.

THE OPERATION OF COMMERCIAL ART

WHEN goods have been made, they have to be sold, and the business of selling goods has during the last three-quarters of a century, become a highly skilled and complex operation, depending upon market research and organised persuasion. This organised persuasion is directed to the consumers of goods, and for its effectiveness it depends partly upon the appropriate use of the various forms of commercial art. It was said in Chapter I that the most familiar manifestations of this branch of industrial art were press advertisements, posters, window bills and signs, trade literature, such as booklets, leaflets and folders, display material for shop windows, counters and showrooms, exhibition stands, and the design of packaging. All these activities of the commercial artist and industrial designer are at some time or other brought into the service of distributing goods; and modern methods of propaganda, of organised persuasion, include cinema films and radio broadcasts.

Commercial art may therefore be divided into two main sections: (1) Advertising, and (2) Display. Under the first may be included press advertisements, posters, streamers and trade literature: under the second, signs, display material for shop windows and showrooms, exhibition stands and packs of all kinds, tins, cartons, containers, wrapping papers and foils. Those who design for advertising use two dimensions: those who design for display use three. It should be appreciated that this branch of industrial art has more ramifications, a greater variety of forms, and commands a larger share of creative activity than any other: it gives daily visible proof of its presence, and puts on a continuous performance of persuasion to potential consumers of the goods and services on whose behalf it is employed. It is the concern of this chapter to indicate its character, and the range of its technical achievements: a full study of the subject would demand a long book, and a considerable literature on its various branches already exists.

It is from the display of goods that other methods of drawing attention to their presence and their merits have gradually evolved.

At first it was considered necessary merely to draw attention to the presence of goods or services at their place of sale or operation. Various symbols were used, of which the barber's striped pole and the three gilded balls of the pawnshop are the most familiar survivors. Sometimes an old-fashioned chemist's shop will still display the gilded mortar and pestle, which was the apothecary's sign. The use of appropriate symbols to denote different trades and crafts persisted for centuries, and some of them gave individual and striking emphasis to the character of a business. For example, a cabinet-maker who worked in London during the reigns of William and Mary, Queen Anne and George I, carried on his business at the Carved Angel in Aldermanbury.¹ Even when new trades were introduced their practitioners often adopted a symbol; and as late as the second half of the nineteenth century, we find shops where umbrellas could be bought, repaired and re-covered, hanging out an open umbrella covered in red, ten feet or so above the pavement. Umbrellas had been made familiar in England during the eighteenth century, by Jonas Hanway, the philanthropist; but it was not until gingham was used instead of oiled silk, and William Sangster took out a patent in 1848 for alpaca as a covering, and the opening and shutting mechanism was improved, following the introduction of the "Paragon" rib which Samuel Fox patented in 1852, that the umbrella trade expanded and the reduced price of the article created many thousands of fresh consumers. Then umbrella vendors used a symbol, just like mediaeval traders. The influence of the mediaeval tradesman still remains, and is apparent in many shopping streets, particularly in some of the older cities of England, like Chester and York.

In the Middle Ages, when cities were enjoying reasonable security behind their walls, and London merchants were acquiring enough power occasionally to intimidate kings and great noblemen, the shop was not the highly specialised and elaborately equipped place it subsequently became. Originally, it was either part of a warehouse, or was a crude stall, set up on a rented pitch in a street, leaning against a house, and often by the entrance to a cellar. The merchant who owned the warehouse had a special room where customers could inspect his goods: that became the shop, and its presence was denoted by a painted sign. The sign-writer was the commercial artist of the mediaeval city, and his work brought lively colour to its narrow, filthy streets. A picture of the congestion of those obstructed shopping streets is given by S. O. Addy, in *The Evolution of the English House*. "To this day," he writes, "English shopkeepers

prefer narrow streets, as, for instance, New Bond Street in London. Experience has shown them that more business can be done in such streets. The practice of touting at the shop door for custom was of long duration. An English poet of the fourteenth century [Langland] laughed at the noises they made in the streets, as when cooks and their servants cried 'hot pies, hot!' Such was the narrowness of the streets, and such the importunity of the shopkeepers, that if a man got into a street at one end he could hardly get out at the other without buying something. It was the old way of advertising."²

Only at great fairs and on small street and market stalls were goods openly displayed. Some of these fairs were annual trading events of European significance, and in England the most famous were those held at King's Lynn and Stourbridge; it was only on such occasions that traders enjoyed any approach to equality of opportunity. One authoritative writer on mediaeval trade has suggested that this equality among traders "partly explains why the fairs became so popular, and why they were viewed with jealousy by many towns. In fact, London tried for a time to boycott Stourbridge Fair, but without success."³ The fairs persisted, becoming an integral part of English life, and the extent and diversity of trade carried on all over the country by these events is recorded in William Owen's *Book of Fairs*, originally published by the King's authority during the reign of George II, which ran into several editions during the eighteenth century. Many of these fairs have since been abandoned, for cities have spread out and engulfed the villages and little towns where they were held; some have survived, though they are now concerned almost exclusively with horses, cattle and agricultural produce.

The first industrial revolution gave a new and more ambitious form to fairs; and during the latter part of the nineteenth century, national and trade exhibitions became popular. Large scale exhibitions, providing new and unusual opportunities for the display of goods, housed in specially designed buildings, began in Britain with the Great Exhibition of 1851 and in the United States with the New York Fair of 1853. Both were accommodated in exhibition buildings of glass and iron, though Paxton's Crystal Palace was the most distinguished and original of the two. Within the great building set up in Hyde Park a fine orderliness of lay-out was apparent; but this example was forgotten. Very soon large scale exhibitions were accommodated in buildings that were often admirable pieces of structural engineering, but they were not left undisguised, like the Crystal Palace: they were "veneered" with what was thought to

be "architecture." Inside these halls and palaces of steel and stucco, merchandise and industrial products were displayed with the most incongruous accessories. The orderly classifications of the Great Exhibition were abandoned, and visitors were confused by a fortuitous concurrence of objects. Machinery would gleam here and there amid palm stands; beautifully made mechanisms would operate between trailing clouds of geranium and petunia depending from the roof girders in moss-lined baskets of galvanised wire. Great expanses of plate-glass were elevated upon polished mahogany stands, and they screened all manner of goods. In London, the pre-1914 White City, which combined the attributes of the "Fun Fair" and the commercial exhibition, was thought, when the Franco-British Exhibition opened, to reach the highest standard of display and lay-out. The glittering congestions of that exhibition were to be accepted as standards of display and arrangement until 1924, when, largely owing to the persistent advocacy of the late Sir Lawrence Weaver, designers were given an opportunity of producing a tidy, orderly and lucid display of goods and services at the British Empire Exhibition held at Wembley. A year before, at Gothenberg in Sweden, a remarkable little exhibition had been staged, which demonstrated the unity and individuality an exhibition could attain when it was the work of a competent designer. It was an exhibition of a new type and it drew people from Britain and all over Europe to Sweden. The British press gave more attention to the 1923 Gothenberg Exhibition than it normally gives to that order of foreign affairs. A campaign to make the British public "exhibition-minded" began in 1923, for the British Empire Exhibition was to open the following year, and Gothenberg showed on a small scale how well an exhibition could be designed and how easily it could transcend the strident jumble-sale-cum-fair of the pre-1914 White City tradition. At Gothenberg many ideas for dramatising the display of goods and services were assembled, and in the national exhibits the vivid presentation of facts that are usually entombed in the tables of Government publications gave memorable pictures of Swedish social and industrial improvements. The whole exhibition was a three-dimensional advertisement for Sweden. The advertising was successful. It created thousands of enthusiasts for Sweden and things Swedish; but it also created a new technique of exhibition design by demonstrating that national and commercial exhibitions *are* advertisements in three dimensions, and that when competent designers are employed to create them, they are as different from the old, muddled, crowded Victorian and Edwardian exhibitions as a skilfully type-set and vigorously illus-

trated modern advertisement is from the hotch-potch of nondescript type-faces that shouted each other down in old-fashioned advertisements.

In exhibition stand design many commercial organisations have become convinced that it pays to employ a specialist to display their goods. This used to be considered the job of the display man or the window dresser. The actual setting out of goods in a window, the arrangement of display sets, the piling up of packaged goods, tins and cartons, is a highly skilled job which has to be carried out by a display expert, but it is not that expert's job to solve all the problems connected with the economical use of a site in an exhibition. Up and down the country during the year in normal times many trade exhibitions are held as well as those to which the general public are admitted. In London alone there were over thirty annual exhibitions, dealing with tobacco, housing and health, brewing, confectionery, grocery, drapery, hair-dressing, radio appliances—to give only a short list. Most of the principal shows are held in London, and they are nearly all duplicated or triplicated in the provinces.

Trade by trade during the nineteen 'thirties commerce recognised the fact that well-designed stands are easier to run, more attractive to the customer, more profitable to the stand-holder. Any architect (or industrial designer) who designs either an exhibition lay-out or an exhibition stand is designing an advertisement for something. He must study the effect his exhibition stand or stands will have upon the potential customers for the products or services that are being advertised or actually sold by that stand. In collaboration with his client he will probably study that problem with the same assiduity as the people whose business it is to prepare advertisements study their problems of appeal and presentation, but unlike them he is not limited to two dimensions.

In the designing of stands architects and industrial designers have met the pride that nearly all manufacturers have in their products, a pride that often leads them to believe that the public knows all about those products and wants to hear as much about them as possible, to see as much as their eyes can take in, and to study where and how they are made. This sort of pride often leads manufacturers to overcrowd their note-paper with lists of the things they make and with bad drawings or worse photographs of their factories; and it affects their attitude towards any public appearance of their wares. Usually the architect who designs a stand for the display of those wares is exhausted after a stiff battle with his client on the matter of overcrowding, and if he attains

simplicity and clarity, and succeeds in preventing the use on an enlarged scale of the name block that was designed for the firm in 1840 or thereabouts, he has done well. But the design of an exhibition stand has to give more than architectural form to a display, more than a compact and economical solution to the problem of showing materials. It has to dramatise the facts about the goods or materials. Stand design is not tied to any particular materials. It is as free from constructional limitations as stage scenery, and to regard an exhibition stand that has to attract a bored and capricious public as anything but stage scenery curbs the inventiveness of a designer. In exhibitions a new form of collaboration between design and industry has been developed. It gives abundant opportunities to designers to inject into this branch of commercial art fresh and vivid qualities, and the distinction attained by well-designed stands should impress everyone with goods or services to sell to the public, or, if they are manufacturers who operate through retail channels, to their own distributors. It needed some years of education before it was realised by commerce and industry that when some hundreds or thousands of pounds for space at an exhibition had been paid, it was worth spending a little more money to see that it was attractively filled. The form of education that was most effective was competition from a few intelligent and progressive people who, searching round for new ideas, had decided to give a fully qualified and inventive designer a chance to be inventive. It is doubtful whether the exhortations of writers, lecturers and publicists who were trying to improve design had much effect on this educational process: only great business executives, like Sir Lawrence Weaver and Frank Pick, people who were actually *doing* important work in commercial and industrial organisations, could by their example prove to other executives that they knew good design was good business.

Display has been our first concern in this chapter, because the stall, the shop, the showroom and the exhibition stand were the original, basic factors in the selling of goods to consumers; and they still are, despite the huge increase of mail-order trading. The need to call attention to goods, to attract people to the place where they are displayed, has gradually brought the practice of advertising into general use. What we know as advertising today, is a highly skilled and largely mechanised amplification of the old cry of "Buy! Buy! Buy!" Advertising was originally verbal; there were trade songs and street cries, verses and airs that were not without merit. Some of these old trade songs are recorded in the works of poets and

dramatists, and perhaps the best known is sung by Autolycus, in Shakespeare's *Winter's Tale*:

“Lawn as white as driven snow;
 Cyprus, black as e'er was crow;
 Gloves, as sweet as damask roses;
 Masks for faces and for noses;
 Bugle bracelet, necklace amber,
 Perfume for a lady's chamber;
 Golden quoifs, and stomachers,
 For my lads to give their dears;
 Pins, and poking-sticks of steel,
 What maids lack from head to heel:
 Come, buy of me, come; come buy, come buy;
 Buy, lads, or else your lasses cry:
 Come, buy,” etc.

In Thomas Middleton's play, *Anything for a Quiet Life* (1617), a mercer's apprentice sings:

“What is't you lack, you lack, you lack?
 Stuffs for the belly or the back?
 Silk grogans, satins, velvet fine,
 The rosy-colour'd carnadine,
 Your nutmeg hue, or gingerline,
 Cloth-of-tissue or tabine,
 That like beaten gold will shine
 In your amorous ladies' eyne,
 Whilst you their softer silks do twine?
 What is't you lack, you lack, you lack?”

These were versions of trade songs rendered by men of genius; but any amount of doggerel found its way into print during the seventeenth and eighteenth centuries. A fair specimen of an advertisement in verse, issued by a Philadelphia store-keeper, is included in the *Journal of Samuel Kelly*, under the entry for November 12th, 1789. Here are two of the seven verses which catalogue the wares stocked by this enterprising American tradesman:

“Cloves, ginger, prunes and silver spoons,
 Both wax and tallow candles;
 Bottles and corks and knives and forks,
 With horn and ivory handles.

THE OPERATION OF COMMERCIAL ART

Starch, mustard, snuff, all cheap enough,
Gloves, ribbands, gauze and laces,
Good castile soap, all kinds of rope,
Bed-cords, plough-lines and traces.”⁴

The large scale industrial production of goods, the branding of all manner of products, the improved methods of distribution which took place during the nineteenth century, and the existence of a public that could read, swiftly changed advertising from a relatively simple business of shouting by salesmen about goods displayed on an adjacent stall, to an elaborate variety of operations. A typical sequence of such operations may be described, which will show how advertising is part of the much larger business of marketing. The need for selling arises in the various stages of distribution after goods have been made. Manufacturers may deal either with a wholesale house or direct with retail distributors. If a manufacturer, say of toothbrushes, is dealing direct with the retail chemists, who would be the distributors for such a product, his travellers must call on individual chemists, and try to book orders for quantities of the toothbrush. If it is a branded toothbrush, an advertising campaign to the public will help to create a demand for it, thus bringing people into chemists' shops to ask for that particular brand. The manufacturer must provide the chemist with show cards and other display material for his window and counters, and must explain to him the extent and duration of the advertising campaign directed to the public, so that the retail chemist who is actually responsible for making the sale to the ultimate consumer, knows what steps the manufacturer is taking to simplify the task of selling. When an advertising campaign is going to be launched to the public for selling the toothbrush, the retailer must be informed several weeks before the campaign appears in the newspapers or in posters on the hoardings, and must be urged to order an adequate stock, so that he has plenty of toothbrushes to meet the demand stimulated by the advertising. A separate advertising campaign directed to the retailer, suggesting a stocking-up scheme, will appear in the trade papers he reads. Display material will be offered, and occasionally manufacturers may sponsor the services of display specialists to put in a special window show in the retailer's shop, to coincide with the opening and duration of the advertising campaign to the public.

The existence of this machinery of selling is seldom suspected by the public, and the operation and economic significance of marketing, sales organisation and advertising, are occasionally misunderstood

by academic economists, who are inclined to dismiss all selling effort as wasteful, degrading and unnecessary. The conflict of opinion on the subject is revealed by two books, which should be read by those interested in industrial art, because they deal with the character of the patronage upon which commercial art depends. One is an acrimonious and well-documented attack upon the technique of advertising, written with interest and clarity by Denys Thompson, and entitled *The Voice of Civilisation*; the other, written with knowledge and intelligence, is by F. P. Bishop, and is called *The Economics of Advertising*.⁵ The late Gilbert Russell in stating that advertising was an immense influence in the life of the community, expressed his belief that "in the main, this influence is for good." He supported this view by saying: "Pretty well every invention of modern times which is now a practical and commercial possibility has achieved its position by advertisement. This applies both to luxuries and to domestic utilities."⁶ This fact is often ignored or minimised by the academic economist.

The technical requirements of advertising are enormous, and although its chief form of expression is through the printing press, it commands in addition to the services of artists, photographers, typographers and advertisement copywriters, those of film and radio producers and script writers, and the skilled direction of marketing specialists who can organise research so that the appropriate objectives are identified, to allow the forces of persuasion to be turned on to the particular class or section of consumers who represent the potential market. All this work goes on as part of the day to day business of selling goods after they are made; for only in the abnormal conditions of war-time or under the organised distribution of a totalitarian state—either fascist or socialist—is freedom of choice denied to consumers, so that they have to learn to want only what they can get, instead of getting what they want. There is no mystery about the part advertising plays in the operation of marketing goods, but there is much ignorance, which often leads to moral indignation, distilled from the purest motives; ignorance of the kind which impels a responsible and painstaking critic like Mr. Denys Thompson to say: "High-pressure advertising could only exist in a society which had created insecurity, anxiety, and neuroses on a large scale."⁷

Advertising to most people means posters. They are the most easily memorable examples; but they represent a comparatively small part of the business of calling attention to various goods and services. A detailed description of the technical structure upon which the making of press advertisements depends would be out of place in a

book that is attempting only to explain the character and general operation and possibilities of industrial art; but in order to show how the work of the commercial artist is used in association with that of other specialists, some account of the tasks involved in creating advertisements is desirable. Advertisements which appear in the press claim a large proportion of the output of commercial artists, who work with visualisers, who are the designers of advertisements. An advertisement designer is concerned with the presentation of an advertisement, with working out of the relationships between masses of type and illustration, and the illumination of the whole theme with an advertising idea. This designer works in collaboration with the advertisement copywriter, and an advertising idea is often the joint product of those two widely differing types of creative mind: visualiser and writer.

Making an advertisement is not confined to the task of using words skilfully and economically and then associating them with appropriate illustrations. A knowledge of the use of words is essential, and this knowledge is not common. Arnold Bennett, in *How to Become an Author*, said: "The first sign of unintelligent writing, the first cause of tediousness, is the presence of ready-made trite phrases."

Those who write books and articles do not always remember that; but the author or journalist who inflicts ready-made phrases and clumsy writing upon his readers is certain of some kind of audience; people have paid for his book or the paper or magazine in which his article appears, and they may read not only what he has written, but may be quite uncritical about his style or his occasional tediousness. His readers are in a receptive mood; they have bought what they hope is going to be entertainment, interest, news or instruction.

The writer of an advertisement must secure readers under very different circumstances. An advertisement dare not be tedious; otherwise it is wasted. An advertisement dare not be unintelligible or in any way obscure; otherwise it is a *disadvertisement* for the firm that issues it. An advertisement is not a good advertisement because it pleases the advertiser; because it seems a dignified announcement; because it looks important and gives the name of the firm in large type and assures everybody who cares to read that Dashing & Dotting, Ltd., have for the past half-century been renowned for the careful attention they give to all orders, for the high standard of their service and the unfailing quality of their goods. Such statements, truthful and dignified though they may be, are merely boring. An advertisement has to fight for its readers. An advertisement should be the dramatisation of an idea, and a good advertising idea

is a thread upon which whole campaigns of advertising may be strung without the thread wearing thin. The idea that vitalises any advertising theme must be of the kind that is capable of simple expression, as in the phrase "Guinness is good for you!" which everybody can remember without effort. There is a Dickensian cheerfulness about the phrase that strikes a responsive chord.

In his book, *Planning Advertisements*, Gilbert Russell listed and described twenty ways of constructing advertisements. In the interval between the world wars, advertising developed many new techniques, which allowed artists to work closely with the printing industry, and by studying its processes and the various methods of reproducing drawings and photographs, to achieve new forms of illustration.

Before 1914 a printing revival had begun and it gained its momentum because advertising provided the patronage for innumerable experiments. Many forcible personalities were connected with this movement, men like Sir Herbert Morgan, Joseph Thorp, R.P. Gossop and many artists and typographers who had taken the trouble to understand the printing press, and who made it work for them as it had never worked before. When in the early years of this century such men set out to improve standards of design in printing and in advertising, they discovered that type-faces in the nineteenth century had suffered from the prevailing ill-taste that had disfigured the form of nearly every object. Letters of the alphabet had acquired a squalid corpulence, a needless brutality or else a spidery complexity. In the latter part of the nineteenth century William Morris had tried to improve standards of type design; but he regarded the printing of a book as an occasion for glorious decoration rather than for the lucid austerity of legible type. In the seventeenth and eighteenth centuries type-faces had been based on the classical letter forms that were incised upon the Trajan Column at Rome, and, as it is stated in the admirable book on typography, prepared, printed and published by the *Pelican Press*: "What makes type more or less legible, and so, in that measure, beautiful, is the degree in which it conforms in its proportions to those great artificers who made the Roman inscriptions and inspired the letter-designing geniuses of all succeeding centuries; the artificers who made the code we daily use and made it technically perfect."⁸

Here indeed is an echo of that sweeping loyalty to a great standard of design quoted in Chapter III in relation to Greek architecture: do these familiar letter forms also "stand alone in being accepted as beyond criticism . . .?" Their basic lines are capable of variation without loss of legibility or good proportion; and there are hundreds

of different type-faces used in printing. This fact still astonishes most people as much as it astonished Dr. Watson, Dr. Mortimer and Sir Henry Baskerville when Sherlock Holmes said: "The detection of types is one of the most elementary branches of knowledge to the special expert in crime," after he had identified some printed words clipped from a newspaper as belonging to a leader in *The Times*. As much variation is possible in the form of the letters of the alphabet, without losing their classical purity of line, as there is with the classic orders of architecture—if the proportions are preserved. A few variations on the word INDUSTRIAL will illustrate these possibilities of variation. The word itself is composed with one exception of letters used in the Roman alphabet; the exception is the letter U. The Roman rendering of the word would be INDVSTRIAL, for U was not then in use.

Type-faces have different names, and they are made in a range of sizes, based on the division of the inch into 72 parts, which are known as points. The smallest type in use for text is 6 point, that is 6 points deep, from the bottom of a letter like p to the top of a letter like b. Such small type is generally relegated to footnotes. This book is set in 11 point Baskerville type. It could have been set in a smaller size, such as 9 point.

And this is what it would have looked like in 9 point.

In 6 point it would have been very much smaller and altogether too trying to the eyes, as this sentence proves because it is set in that size.

For the variations on the word INDUSTRIAL, large sizes of type and capital letters only have been used, so that comparison is simplified. Here is the word set in Caslon Old Face:

INDUSTRIAL

Legibility is undiminished, and the character of the forms is preserved, when the word is set in Open Titling:

INDUSTRIAL

Here the setting is changed to Imprint, which allows rather more variation of form, without altering the basic proportions:

INDUSTRIAL

A bolder rendering still retains the proportions of the letters. For this Heavy Old Face is used :

INDUSTRIAL

And for this, Garamond Bold :

INDUSTRIAL

And here is something lighter, a setting in Garamond :

INDUSTRIAL

During the nineteenth century, many attempts were made to create ornamental or "novel" type-faces, by monkeying with the proportions of the letters, with the unhappy results visible here :

INDUSTRIAL

Observe the top-heaviness of the letter **R**. Worse things were done to this alphabet than the word industrial reveals ; for instance :

G K F E.

The printing revival re-established legibility ; it re-established respect for the proper proportions of the alphabet, so that when, after the first world war, the printing revival entered upon another phase and was influenced by the modern movement in design, and type designers wished to take liberties with the old letter forms, they were far better equipped to do so than the Victorian type designers who were merely out for spurious novelty. The Continental type designers, who were chiefly active in Germany between the wars, were concerned with making dramatic and vigorous signals. They produced the Erbar family, which achieved great popularity. Such types as Erbar may have been conceived by German type founders in a mood of rebellion against the old complex Gothic text which had undermined the national eyesight of Germany for years. The traditional Gothic text was favoured by that romantic European nuisance, Kaiser William II. It was liked by an even greater nuisance. Shadowy, illegible letters went with waxed moustaches, gilded helmets, and the rest of the stuffy, romantic, traditional taste of pre-

1914 Germany. German designers, tired of everything that represented Hohenzollern taste, and impatient of the illegibility of traditional types, created a mechanistic alphabet in which each letter was a clean sharp symbol. To German eyes the new sans serif types were wonderfully legible both for displayed lines and for text; they represented a change as great as the change from a dark room to one flooded with sunlight. The result of their work is best illustrated by Erbar Light :

INDUSTRIAL

Very different is the type designed by Eric Gill, who created his alphabet with English eyes and with the skill of a sculptor and master mason who had for many years cut beautiful lettering in stone, based upon the Trajan Column alphabet. His sans serif type is not just the Roman alphabet with the serifs trimmed off; it is the individual solution of each letter problem, based on giving the simplest expression by a familiar shape, as opposed to the German method of eliminating the soft, familiar features of letters and reducing them to hard bones. This is an example of Gill Sans :

INDUSTRIAL

Compare the **R** in Gill with the **R** in Erbar and the **G** in Gill with the **G** in Erbar.

For the purposes of advertisement display many bold decorative types have been resurrected from the eighteenth or early nineteenth centuries or invented to please advertisement designers. Some of these types are so urgently decorative that their use except for fairly short display lines could not attain legibility. Broadway is an example :

INDUSTRIAL

But both Erbar and Gill demonstrate the basic soundness of their letter forms, particularly when they are varied in weight and character. For instance this is Gill Sans Bold :

INDUSTRIAL

This is Gill Sans Extra Bold :

INDUSTRIAL

This is Gill Sans Extra Light :

INDUSTRIAL

This is Gill Sans Shadow :

INDUSTRIAL

These type variations suggest the range of possibilities open to designers. Lower case letters, as the small letters of the alphabet are called in printing because they are kept in the lower part of the compositor's case where letters are stored, allow even greater variety. The type called Baskerville, which is used for the printing of this book, was invented by an Englishman of that name in the eighteenth century, and a clear and legible type it is; but had this book been printed say in 1870, it might have been set like the next sentence in such a type as Gloucester Old Style :

A book set in this sort of type would be irritating to read, and yet people were continually irritated in this way by printers during the Victorian period, although they were perhaps unconscious of irritation. The next sentence demonstrates another way of exhausting the eye.

This sentence is set in Clarendon, and is not very kind to the eyes, and would indeed be extremely tiring if it was used for a whole book.

Many experiments have been made, and sans serif types, such as Erbar and Gill, have sometimes been used for text, particularly on the Continent. Although such sans serif lettering is beautifully clear for displayed lines and notices, it is less agreeable when used for masses of text. Early in the nineteen 'thirties, *The Week-end Review*, before it lost its separate identity by amalgamating with *The New Statesman and Nation*, tried an experiment on its readers, and set one complete issue in sans serif type, so that every article and item in the journal acquired an unfamiliar form. The next four sentences, which are set in 10-point Gill Sans, show what effect it had.

It is easy enough to read this type for the first few lines, but reading becomes laborious after two or three paragraphs. Practitioners and admirers of the "modern movement in design" are inclined to believe that the use of a sans serif type for the text of a book is another triumph of modernism—that it represents a two-dimensional rendering of the forms

which are handled so boldly, and often so bleakly, by some architects of the modern school. Mr. Francis Meynell has reminded us that only typographers who were ideologists rather than printers, have despised the old canons of legibility.⁹ But perhaps enough has been set in sans serif type to convince the reader that it would be wearisome to continue.

The readers of *The Week-end Review* were most emphatically convinced of the failure of that experiment. Letters poured in to the Editor, begging him to desist, and from those published in the next issue of the paper, it became clear that people preferred the comfort of legibility to the excitement of fashion.

Typography is one of the sections of commercial art which has commanded great talent. The work of men like Stanley Morison, Harold Curwen, Herbert Simon, Oliver Simon, Francis Meynell and Gerard Meynell has given creative impetus to the printing revival.

In the interval between the wars, press advertising changed considerably in character, and it acquired new vitality from the direction of many able designers, who broke away from the accepted convention of advertisement lay-out, which had consisted of a picture with a headline and some copy that was in the nature of a caption to the picture, the whole inert mass being based upon a displayed name, very often in the form of an unalterable name block associated with a trade mark, designed thirty or forty years earlier, which usually injured or limited the power of the advertisement. It has been said that this conventional, static type of advertisement lay-out is analogous, in the disposition of its masses of type and illustration, to the Roman Orders of Architecture; and it is possible to discern a resemblance between the proportions established by the horizontal divisions of an advertisement lay-out and the three broad divisions of the Roman Orders: plinth, column and entablature. The name block and standing matter, address lines and so forth, are held to represent the plinth; the mass of text for the copy, the column space; and the headlines and sub-headlines, the entablature. Presumably, if the analogy was carried to its logical conclusion, the illustration above the headline would be compared with carved decoration on the frieze of the entablature. Such analogies are rather far-fetched and suggest a repressive reverence for fixed proportions while ignoring the principles of architectural composition which alone make the proportions of the classic orders articulate by resolving them into masses and harmonising their individual formality, so that they acquire collective significance. The static, beautifully balanced and symmetrical advertisement lay-out is tremendously gratifying to its maker. Actually he is being as dully uninventive as a Victorian or

an Edwardian architect, who lacquered some architectural style based on the classic orders over the front of his building. The neat and static advertisement lay-out can be, and often is, legible. It is acceptable to the taste of the connoisseur of typography in its well-chosen association of headline and text. But the dynamic lay-out aims at interruption without irritation, cuts sharply through all the trappings of tradition, and becomes a flashing statement in which type and illustration work together, not in any set relationships, but in some unforgettably graphic arrangement.

It is to such designers as Ashley Havinden and E. McKnight Kauffer that we owe the development of this particular technique in Britain. For this technique of advertisement design there are materials in abundance, but its effectiveness depends, not upon the particular materials that are employed, but upon the manner in which the problem of design is approached.

Before 1939 a far greater number of competent designers found employment in connection with distribution than with production. Advertising has provided abundant and encouraging patronage for design. Commercial art as a result is healthy and vigorous and has attracted some first-class talent. Other branches of industrial art could attain the same standards of health, if manufacturers encouraged designers to develop the questing, experimental outlook that distinguishes the men who do the best work in advertisement design.

THE DESIGNER AND THE FUTURE

THE three main divisions of industrial art set forth in the first chapter have been examined. Industrial design, commercial art, and industrial architecture, have been discussed, and the sub-divisions of industrial design, have, with one exception, been illustrated and explained. The exception is the final sub-division, namely industrial decorative art, which covers the creation of decorative patterns, and the choice of colours and texture, for such things as pottery, textiles, wallpaper, and domestic glass. This branch of industrial art comes more directly under the control of fashion than any other; it is more susceptible to the variations and idiosyncrasies of personal taste, less influenced by functional requirements and affords more opportunities to the type of creative mind that excels in the invention of decoration, for the artist's freedom is limited only by the need for studying the processes whereby his patterns are ultimately reproduced. Any discussion of this type of work is apt to be distorted, or at least powerfully affected, by personal likes and dislikes. The expression of mere preferences for geometrical or floral motives, irregular splashes, dots and dashes, or what are called abstract shapes, is often invested with an air of pontifical authority, as misleading as Ruskin's public proclamations of his personal taste for Gothic forms and ornamentation. Some people are delighted by the firm but delicate lines of Keith Murray's domestic glass exemplified by the decanters and wine glasses he designed for Stevens & Williams, Ltd.; others admire exuberant or severe brilliant cutting on the surface of some well-shaped glass object. We are inclined to make a moral issue of our preferences. Perhaps it is because we are still suffering from inherited ideas about pattern, that we are impelled to justify either our acquiescence or insurgency.

Roger Fry in his essay on "Art and Socialism" deplored the immense amount of potential creative power that is deflected to the business of producing "dead patterns."¹ Published originally in 1912, that critical essay is valid in the year 1945, for it is still the doom of many skilful men and women to copy and combine ornamental

motives from which vitality has long departed, motives which were once fresh and lively and applicable to the needs and taste of contemporary life. "They are," said Roger Fry, "by far the most numerous 'artists' in the country. Each of them has not only learned to draw, but has learned by sheer application to put forms together with a similitude of that coherence which creative impulse gives. Probably each of them has somewhere within him something of that creative impulse which is the inspiration and delight of every savage and primitive craftsman; but in these manufacturer's designers the pressure of commercial life has crushed and atrophied that creative impulse completely. Their business is to produce, not expressive design, but dead patterns."

These people and the manufacturers for whom they work are perpetuating the mistakes of the first industrial revolution, and the acceptance of their "dead patterns" will continue until the consuming public is educated to the point of exerting critical discrimination. That may not happen for two or three generations, for, as we pointed out in Chapter IX, it is a long job to educate and persuade people in a democracy, until on their own volition they observe and compare before they choose and buy. Meanwhile, the whole question of taste for pattern is confused by the tendency, described in Chapter II, of contemporary industrial designers to create smooth, continuous surfaces for articles that have a mechanical or semi-mechanical function. This tendency is often presumed to imply the extinction of pattern: the ancient human desire to ornament surfaces is held to be incompatible with the characteristic forms and textures made possible by a proper understanding of the gifts of the second industrial revolution. But the dilemma hardly exists for those designers whose understanding of the gifts of the second industrial revolution is lit with imagination.

Those whose talents and inclination have led them to concentrate on industrial decorative art occasionally derive fresh inspiration from the study of the other and more exacting branches. Designers who are chiefly concerned with function and shape are technicians with a different quality of imagination and a different background of training from those who prefer to devote their creative powers to inventing patterns. It was said in Chapter II that the industrial designer is a technician, whose work should begin at the same time as the work of other technicians—the production engineers, the specialists in materials and the experts who have studied the potential market. He is not a "stylist," to be called in when materials have been selected and the technical problems of production settled.

What sort of a background of training does the industrial designer have?

In Britain, he is only just emerging as an independent specialist, only just beginning to gain recognition, and being identified as the missing technician in industrial production. Many of the leading British industrial designers are architects, for the architect is almost the only professional type of man who is trained to think lucidly and logically about problems of design. He is trained to employ a perplexing diversity of materials for carrying out his work in building, and his ability to plan has been sharpened and disciplined by study. An industrial designer who is an Associate or a Fellow of the Royal Institute of British Architects has qualifications which can only be obtained by long and exacting training. That training provides an authoritative technical background and implants a feeling of independence about materials; independence in the sense that the architect is neither browbeaten by materials, nor over-masterful in using them. To an understanding and respect for their limitations, which he has learned by hard work, he adds an eagerness for experiment, if he is of the stuff of which original industrial designers are made.

H. G. Wells once said that "Painting, sculpture, all furnishing and decoration, are the escaped subsidiaries of architecture, and may return very largely to their old dependence."² The architect was once the master specialist in a universally recognised and practised system of design, and in Chapter III it has been recorded how during the years that lay between 1660 and 1830 the influence of his skill, knowledge and imagination was ubiquitous. But although some of the "escaped subsidiaries" returned to architecture during that period, the architect lost his control of design as the first industrial revolution developed. Now, as the second industrial revolution is beginning to change the character of industry, and new techniques and new materials have to be studied, the architect has an opportunity for regaining, as an industrial designer, that lost control—if he is prepared to accept such a considerable responsibility.

The practice of co-operation between designers and manufacturers has been growing, and hitherto the architect is the only designer whose training is such that the manufacturer may be reasonably sure of getting intelligent and practical advice from him. Architectural and industrial design may in time become corresponding studies: many chapters of this book have shown how closely they are connected. The architect could become recognised as *the* expert on design in the community. It may again be repeated that design

is a technical operation which must be conducted like any other business; and an architect learns not only how to design and handle materials, but how to use his learning in a practical and business-like way. Unless he does so, he becomes an expensive nuisance to his clients, and ultimately fails to have any. The manufacturer who is introduced to an industrial designer who is also an architect is not required to overcome any awkward prejudices he may have at the back of his mind about "unpractical artists"—prejudices which frequently occur because "the artist has no particular status."

There is a need for a trustworthy qualification for ability and experience in industrial design which would be recognised and acceptable, and would guarantee a background of study, training and accomplishment, comparable to that denoted by fellowship or associateship of the Royal Institute of British Architects. There is a coveted and rare distinction conferred by the Royal Society of Arts upon industrial designers. The Society is the principal authoritative body in this country which is concerned with industrial design. It has prestige and a long history of achievement and educational effort. In 1937 the Council of the Society made an Ordinance, intended to encourage a high standard of industrial design, and to improve the status of industrial designers. Through it, the Society selected for special distinction designers who had gained eminence in creative design for some branch of industry. This Ordinance permitted the Council to confer upon British subjects who had obtained such eminence the title of "Designer for Industry of the Royal Society of Arts." Every person granted this distinction was given a Diploma, issued under the authority of the Council, and was allowed to use the letters R.D.I. after his name. A provision of the Ordinance restricted the number of holders to forty.

The creation of this distinction has had a marked and important effect upon the attitude of many industrialists and industries towards the designer. It is realised that such a distinction is not lightly given, and it is also realised that a man with the letters R.D.I. after his name is one whose work has passed severe and searching tests; whose work and experience are therefore to be trusted; whose eminence and ability are beyond dispute. It is significant that several of the distinguished designers who are entitled to write R.D.I. after their names are architects—Brian O'Rorke, Keith Murray, Charles Holden, Wells Coates for example.

What else exists?

There is the National Register of Industrial Art Designers, mentioned in Chapter VIII, to which a designer may submit work. If

it is approved he is allowed to use the letters N.R.D. after his name. The National Register began work in 1937 and within six years had registered over seven hundred designers whose work had reached the standard required by the adjudicating committees which scrutinise the specimens submitted by candidates for admission. Its scope is broad, but the letters N.R.D. at least guarantee elementary competence, and protect the industrialist from the claims of the amateur dabbler, or the inexperienced student.

The status, training and future place of the industrial designer were examined in a comprehensive memorandum, prepared by Dr. Nikolaus Pevsner in 1943 for *The Arts Enquiry*, which was sponsored by the Dartington Hall Trustees in co-operation with the Nuffield College Social Reconstruction Survey. With Dr. Pevsner's permission, some quotations are made from this document, and the views of such an independent and penetrating mind deserve the closest attention. His ideas about a useful curriculum for art schools, where designers could receive preliminary training, are suggestive.

"It should begin," he writes, "in the same way for painter, sculptor, craftsman and designer. Drawing and modelling, elementary study of materials and elementary study of abstract shape and colour is equally necessary for all. Nor should any of these subjects be given up when the moment for specialisation has been reached. At that stage, the stage at which the artists separate from the craftsmen, and the craftsmen from the designers, another separation is also necessary. The 'lower school' might be situated anywhere, though a cultural centre will as a rule be of advantage. (I say, as a rule, because Dessau in the days of the Bauhaus was an overwhelmingly provincial, though not a dingy or dirty town.)

"Directly design becomes the main subject, students must be in touch with industry. For it is the most thorny problem for a design school to create, in the sheltered atmosphere of a school, conditions similar to those in the world of factory and board room. To establish a fruitful co-operation between teaching of design and practice, the best system seems that of the local or regional college. Let all aid that can be given to training facilities in design for weaving go to the centres of textile industry; all aid allocated to pottery design (not the craft of potting) to the Five Towns, etc. Such aid should not be only local, the financial burden should at least partially be national. Within a scheme of national planning and its regional sub-divisions, and within what educational reforms the years after the war will bring, there should be a re-consideration of school finance. At present the Royal College of Art is the only State school

of art. That is not enough. The Royal College can serve the country to the full only if it is the superstructure of a system of supporting (and supported) regional colleges, as here proposed. Considering the national importance of good design in industry—even if more one of prestige than of finance—the Board of Trade and the Board of Education should give adequate help to such regional or municipal centres.

“This does not mean, however, that a central authority should be wholly responsible for design education, or even that public finance should be the only means of existence of art schools. The co-operation of industry has by progressive art schools been sought for a number of years—not with very spectacular success. It may be assumed that relations between the two will improve, when an industry sees the local art school specialise seriously in the teaching of design for that same industry and doing so in a realistic spirit.

“The curriculum of a regional college of design (the term taken in its widest sense) should provide a continuation of courses in materials and form, and courses in freehand drawing and modelling, and add to these on the one hand the crafts related to the prevalent industry of the region, and on the other the technical instruction which, with its machine requirements, may best be given at the local College of Technology. If College of Design and College of Technology can be in such close neighbourhood and such amicable relations as has been achieved at Leicester, much is won. In other cases it may prove more satisfactory to acquire the necessary machinery for the College of Design itself. In this respect especially a friendly attitude of industrialists will be of value.

“The courses at these colleges should lead to a degree testifying to the past-student’s technical proficiency and to his design abilities. The examination should represent the same standard as the R.I.B.A. Final. It has often been said that design cannot be examined because of the impossibility of judging in matters of aesthetics, and that therefore a design diploma would not carry any weight with industrialists. But the architectural examinations as established in this country also include matters of design and have yet been generally accepted as yielding reliable results.

“Out of each year’s students at the Regional Colleges there should be a member selected for post-graduate work at the Royal College. This could thus be developed into an establishment of the very highest standard. Work should not be with a bias to special industries, but of that general kind which has made it possible for the best industrial designers in America to evolve a refrigerator, cooking utensils and pressed glass tumblers all at the same time, or for Eric

Ravilious to design pottery decoration, glass decoration and furniture. Where facilities of factory experimenting will be needed, the College should try to establish connection with the wide variety of industries carried on in the London area. Manufacturers will, it can be hoped, soon find that College students of post-graduate standards will be an asset rather than a nuisance. The proximity to courses of equally high standard in painting and sculpture would be of the greatest benefit to the designer as well as the painter and sculptor. The Bauhaus has been a proof of how valuable the teaching of abstract artists such as Klee, Feininger and Kandinsky could be to men busy on working out models for the mass production of lamps or kitchen cupboards. At the Bauhaus in its earliest days, the students worked all the time under two masters, an artist and a technical instructor. The system proved difficult to operate, and was later given up. The method here suggested would probably have the same advantages, provided a real team-spirit can be established on the staffs of the various schools between technician, designer and artist.

"Numbers in these Royal College courses would at no time be considerable. An inflation of the courses must, in fact, be carefully avoided. This point needs stressing, because there exists in Government departments a pride in numbers which is a mistaken pride. Classes of many tend to reduce standard, and also prospects of adequate employment. A country needs not many designers of the very highest calibre. In America, where heavy industries have become exceedingly design-proud during the last ten or twelve years, there is hardly more than a dozen designers who have succeeded in pushing their way into the front rank. This is partly due to the fact that locomotives, motor cars, refrigerators, office machinery, radio cabinets, etc., are produced by comparatively few big combines and with only few new designs each year. It would not to the same extent apply in Britain where, e.g., the textile and pottery industries require many new designs at a rapid rate of change. However, there will never and nowhere be scope for more than a few leaders.

"The majority of design college students of promise should pass from the regional colleges straight into the industries for which they have been specially schooled. It is here that the most important job of work is to be done. I have in my *Enquiry into Industrial Art in England*³ given some figures illustrating the scandalous dearth of fully equipped and fully employed designers in the pottery, jewellery, leather and other trades. Design standards will not go up until competent designers—competent technically as well as aesthetically—are drafted into such industries. I am confident that they will be

available as soon as the educational system supplies them with an adequate equipment. Talent is not missing. England has for a long time suffered from an aesthetic inferiority complex. But the land of Chippendale, Wedgwood, Morris, Emery Walker, Eric Gill cannot be devoid of design genius."⁴

Here is a clear and wise outline of educational possibilities, some of which may be realised, partly as a result of the work initiated or encouraged by the Council of Industrial Design. Dr. Pevsner's insistence on the high quality of potential designers, his reference to the mistaken pride of Government departments in mere numbers, and his acceptance of the inescapable fact that "there will never and nowhere be scope for more than a few leaders" establish him as a realist as well as an authority on education.

When the industrial designer has been trained he must attain a status at least equal to that of the architect. Frank Pick, in his introduction to the English edition of *The New Architecture and the Bauhaus* by Walter Gropius, said: "At one time I thought that maybe architects had limited the scope of their training too narrowly in relating it to building, especially when I saw them venturing into other fields of design such as furniture, decoration, pottery and so forth, but I see now that I was not right. The designer for industry must be placed alongside the architect, with a training equivalent in character, if directed towards another end, and with a status and authority equivalent too."⁵

In the United States he has attained that status. He is accepted as a technician; his work is a recognised part of industrial production; his name is often a household word, for American industrialists and distributors realise that good design may have real selling power and that the name of a good designer, associated with their products, stimulates the interest of the purchasing public. The work of the great American industrial designers is "news"; their names stand for enterprise, improvement and progress. An amount of bogus streamline novelty-mongering is intermingled with American industrial art; but that is inevitable in a great trading community with a genius for salesmanship and showmanship. Industrial design is vigorously alive in the United States, and is accepted by the business community as normal and necessary. The fact that it is accepted and practised as a business operation is perhaps repugnant to reformers who feel that improvement in design should be part of a social and economic revolution; but it is also a fact that designers have more opportunities and consumers can choose from a far greater variety of well-designed products in America than in Britain.

Writing in the *Board of Trade Journal* on "Design for Home and Export," Mr. S. C. Leslie, the Director of the Council of Industrial Design, has said: "The present level of industrial design in Britain is the result of deep-rooted habits and practices, not to say prejudices, among manufacturers, distributors and the public. To raise it means breaking a vicious circle. You can begin the circle anywhere you like. It runs round from a public too little trained in careful discriminative purchasing to a distributor naturally anxious to play safe and 'get his figures' by attempting to repeat last year's successes; then back from the distributor to a manufacturer equally tempted to play safe in the home market and not always clearly aware of the importance of the design factor in developing markets abroad; on again to a system of art and design education which, whoever is to blame, does not produce trained craftsmen and designers such as industry is willing to employ in adequate numbers; and so back again to the public which has accepted and tolerated this state of affairs."⁶

Seldom has one of the major problems of our time been so neatly stated. That it has been officially recognised as a major problem by the Board of Trade is proved by the formation of the Council of Industrial Design; only when it is generally recognised as a major problem by industrialists, distributors and educational authorities, shall we be in sight of a solution, for it can exist only while those three responsible parties remain ignorant of the fact that it is a problem. They are respectively responsible for the making of goods, the selling of goods and the ultimate taste and judgment of the consumer.

This book began with the statement that industrial art may in time to come be regarded as the characteristic achievement of our civilisation. It is important that it should be recognised as a contemporary achievement, otherwise it may have no future. In Britain there are some of the most talented industrial designers and artists in the world. Their trained imaginative powers represent an asset that has for far too long remained a hidden asset in our national balance sheet. After a period of shortage, when almost anything in the way of goods however ill-designed or outmoded can be sold almost anywhere, we shall have to make full use of those latent powers if we are to revive, maintain and extend the prestige and sales of British goods abroad. At home, as the partners in industrial art—manufacturers, designers and distributors—realise their mutual dependence, and work together as partners should, we may in time restore to our environment a visual serenity comparable to that which our great-great-grandfathers enjoyed.

SOURCES OF REFERENCES IN THE TEXT

CHAPTER I

¹ *Mémoires sur les coutumes de Cambodge*, etc. in *Bulletin de l'École Française d'Extrême Orient* (Vol. II). Many passages are translated into English by Sir Osbert Sitwell in his book, *Escape With Me!* (London: Macmillan & Co., 1940.)

² *Towards Angkor: in the Footsteps of the Indian Invaders*, by H. G. Quaritch Wales. (Harrap & Co. Ltd., 1937.)

CHAPTER II

¹ *Roman Britain and the English Settlements*, by R. G. Collingwood, F.B.A., and J. N. L. Myres. (Oxford University Press, 1936.) Chapter XIV, page 236.

² *Progress and Archaeology*, by V. Gordon Childe. (London: Watts & Co., 1944.) Chapter III.

³ *The Mongol Empire*, by Michael Prawdin. (London: George Allen & Unwin, Ltd., 1940.) Chapter XXX, page 472.

⁴ *The Greek View of Life*, by G. Lowes Dickinson. (Eighteenth edition. Methuen & Co.) Chapter III.

⁵ *Progress and Catastrophe*, by Stanley Casson. (London: Hamish Hamilton, 1937.) Note in Chapter XVII.

⁶ *A History of Europe*, by H. A. L. Fisher. (London: Edward Arnold & Co., 1936.) Chapter XXIX.

⁷ *History of England*, by G. M. Trevelyan. (London: Longmans, Green & Co., second edition.) Book V, Chapter VII.

⁸ *The Missing Technician in Industrial Production*, by John Gloag. (London: George Allen & Unwin Ltd. Second revised edition, 1945.)

CHAPTER III

¹ Introduction on "The Study of Architecture," by John Gloag, to *A Short Dictionary of Architecture*, by Dora Ware and Betty Beatty, A.R.I.B.A. (George Allen & Unwin Ltd., 1944.)

² *The Works of Man*, by Lisle March Phillipps. (Duckworth, second edition, 1914.) Chapter IV.

³ *The Art of Architecture*, by A. E. Richardson, A.R.A., F.S.A., F.R.I.B.A., and Hector O. Corfiato, S.A.D.G., F.R.I.B.A. (The English Universities Press Ltd., 1938.) Chapter II.

⁴ *A History of Architecture on the Comparative Method*, by Sir Banister Fletcher, P.P.R.I.B.A., F.S.A. (Batsford, eighth edition, 1929.) Part I, page 68.

⁵ *Experiment in Autobiography*, by H. G. Wells. (Victor Gollancz, Ltd., 1934.) Volume II, Chapter VIII.

⁶ *Euripides and His Age*, by Gilbert Murray. (Thornton Butterworth. Tenth impression, 1937.) Chapter I.

⁷ *The Architecture of Marcus Vitruvius Pollio*, in ten books, translated from the Latin by Joseph Gwilt. (London: Priestley & Weale, 1826.) Book IV, Chapter I.

⁸ *Anglo-Saxon Art to A.D. 900*, by T. D. Kendrick, M.A., F.S.A. (Methuen & Co., 1938.) Section II, Roman Britain.

⁹ *The Englishman's Castle*, by John Gloag. (Eyre & Spottiswoode Ltd., 1944.) Chapter VII.

¹⁰ *Men and Buildings*, by John Gloag. (Country Life Ltd., 1931.) Chapter VI, page 71.

¹¹ *Ibid.*, page 74.

¹² "The Work of the late Sir Edwin Lutyens," by H. S. Goodhart-Rendel, PP.R.I.B.A. *Journal of the Royal Institute of British Architects*, March, 1945, page 127.

¹³ *The Torrington Diaries*, containing the tours through England and Wales of the Hon. John Byng, between 1781 and 1794. (Eyre & Spottiswoode Ltd., 1934.) Volume I, page 184.

¹⁴ *Ibid.*, page 18.

¹⁵ *An Early Experiment in Industrial Organisation*, being a History of the firm of Boulton & Watt, 1775-1805, by Erich Roll. (Longmans, Green & Co., 1930.) Part II, Chapter I, page 153.

¹⁶ *The Industrial Development of Birmingham and the Black Country, 1860-1927*, by G. C. Allen. (George Allen & Unwin Ltd, 1929.) Chapter II, page 31.

¹⁷ *Memoirs of William Hickey, 1749-1775*. Edited by Alfred Spencer. (Hurst & Blackett, 1914.) Chapter VII, page 75.

¹⁸ *London and its Environs Described*. (London: printed for R. & J. Dodsley, 1761.)

¹⁹ *The Ambulator; or a Pocket Companion for the Tour of London and its Environs*. (London: 1811. Eleventh edition.)

²⁰ *Ibid.*

²¹ *The Gothic Revival*, by Sir Kenneth Clark. (Constable & Co., 1928.)

²² *Ibid.*, Chapter IV, page 76.

²³ *The True Principles of Pointed or Christian Architecture*, by A. Welby Pugin. (London: John Weale, 1841.) Pages 23-25.

CHAPTER IV

¹ *Theory and Elements of Architecture*, by Robert Atkinson, F.R.I.B.A. and Hope Bagenal, A.R.I.B.A. (London: Ernest Benn Ltd., 1926.) Vol. I, Part I, Chapter I, page 6.

² *The Lives of the Engineers*, by Samuel Smiles. (John Murray, 1862.) Vol. II, Chapter VII, page 359.

³ *John Nash*, by John Summerson, A.R.I.B.A. (George Allen & Unwin Ltd., 1935.) Chapter II, page 44.

⁴ *Ibid.*

⁵ *Cast Iron in Building*, by Richard Sheppard, F.R.I.B.A. (George Allen & Unwin Ltd., 1945.) Section I.

⁶ *Ibid.*, Section IV. Also "What is Wrong with Cast Iron?" by M. Hartland Thomas, F.R.I.B.A. *The Official Architect*, May, 1945, Vol. VIII, No. 5.

⁷ *The Seven Lamps of Architecture*, by John Ruskin. Preface to the second edition.

⁸ *Essay on Beauty*, by Francis Lord Jeffrey, and *Essays on the Nature and Principles of Taste*, by Archibald Alison. (Edinburgh: Alexander Murray, reprint of the fifth edition, 1871.)

⁹ *Rides on Railways, leading to the lake and mountain districts of Cumberland, North Wales and of Derbyshire, with a glance at Oxford, Birmingham, Liverpool, Manchester, and other manufacturing towns*, by Samuel Sidney. (London: William S. Orr & Company, 1851.)

¹⁰ *Ibid.*, pages 8-14.

¹¹ *Our Iron Roads, their History, Construction and Social Influences*, by Frederick S. Williams. (London: Ingram, Cooke & Co., 1852.)

¹² *Ibid.*, Chapter VII.

¹³ *Anticipations*, by H. G. Wells. (Chapman & Hall Ltd., 1902.)

¹⁴ *The Revolutions of Civilisation*, by Sir William Flinders Petrie. (Harper & Bros., third edition, 1922.)

¹⁵ Report in *The Times*, May 4, 1934, page 9.

CHAPTER V

¹ *A Miniature History of European Art*, by R. H. Wilenski. (Oxford University Press, 1930.) Section V, page 46.

² *Report of the Committee appointed by the Board of Trade under the Chairmanship of Lord Gorell on the Production and Exhibition of Articles of Good Design and Everyday Use*. (London: H.M. Stationery Office, 1932.)

³ Lecture XIII. These lectures were published in book form under the title of: *Fine Art, a sketch of its History, Theory, Practice and Application to Industry*.

⁴ *A History of the Royal Society of Arts*, by Sir Henry Trueman Wood. (London: John Murray, 1913.) Page 389.

⁵ *Railway Rides*, page 80.

⁶ *Ibid.*, page 94.

⁷ *Lectures on the Results of the Great Exhibition of 1851*, delivered before the Society of Arts, Manufactures and Commerce, at the suggestion of H.R.H. Prince Albert, President of the Society. (London: David Bogue, 1852.)

SOURCES OF REFERENCES IN THE TEXT

⁸ Sir Henry Trueman Wood's *History of the Royal Society of Arts* gives a minutely detailed account of the Society's activities from its inception until 1880.

⁹ *History of the Royal Society of Arts*, Chapter XVII, page 403.

¹⁰ *Ibid.*, page 404.

¹¹ *Ibid.*, page 405.

¹² *Railway Rides*, page 78.

CHAPTER VI

¹ *Victorian England*, by G. M. Young (Oxford University Press, 1936). Section IV.

² *The Life of George Stephenson and of his son, Robert Stephenson*, by Samuel Smiles. (John Murray, 1868.)

³ *Ibid.*

⁴ *Ibid.*

⁵ *The Torrington Diaries*. (Eyre & Spottiswoode Ltd., 1934.)

⁶ *Railway Rides*, page 23.

⁷ *The American Nation: A Short History of the United States*, by John Gloag. (Cassell & Co. Ltd., 1942.) Chapter VIII, page 84.

⁸ *Samuel Kelly*, the Diary of an Eighteenth Century English Sea Captain. Edited by Crosby Garstin. (Jonathan Cape, 1925.) Part II, Section 13, May 11th, 1790.

CHAPTER VII

¹ *A Journey to the Western Islands of Scotland in 1773*, by Samuel Johnson. Section on Inverness.

² *The Englishman's Castle*, by John Gloag. (Eyre & Spottiswoode Ltd., 1944.) Chapter III, pages 23-25. Also, *Heimskringla: The Olaf Sagas*, by Snorre Sturlason. King Olaf Trygvesson's Saga. (Everyman's Library.) Chapter XCV, page 77.

³ *The Village Carpenter*, by Walter Rose. (Cambridge University Press, 1937.) Chapter II, page 17.

⁴ "National Design in Printing," by Francis Meynell. A lecture delivered at Burlington House, April 8th, 1943, to the Design and Industries Association. Reprinted in a pamphlet entitled *Four Lectures on Design*. (London: Hutchinson & Co.)

⁵ *William Morris*, by Montague Weekley. (London: Duckworth, 1934.)

⁶ *Men and Buildings*, by John Gloag. (Country Life Ltd., 1931.) Chapter VIII, pages 136-140.

⁷ *Form in Civilisation*, by W. R. Lethaby. (Oxford University Press, 1922.) "Art and Workmanship." Chapter XIX, page 211.

INDUSTRIAL ART EXPLAINED

⁸ *Design and Mass Production*, by Dr. Gregor Paulsson. (Published by the Design and Industries Association with No. 16 of the *D.I.A. Quarterly*, September, 1931.)

⁹ *English Furniture*, by John Gloag. (The Library of English Art, second revised edition, A. & C. Black, 1944.) Chapter VII, pages 130-135.

¹⁰ Included in two books by John Betjeman, *Mount Zion* (London: The James Press, 1932) and *Continual Dew* (London: John Murray, 1937).

CHAPTER VIII

¹ *Report of the Gorell Committee on Art and Industry*. (H.M. Stationery Office, 1934.)

² *The Economic Laws of Art Production*, by Sir Hubert Llewellyn Smith. (Oxford University Press, 1924.)

³ *Design in Modern Industry*, the Year Book of the D.I.A. (Benn Brothers Ltd., 1922.)

⁴ *Plastics and Industrial Design*, by John Gloag, with a section on the properties and uses of the materials by Grace Lovat Fraser. (George Allen & Unwin Ltd. Second impression, 1945.)

⁵ *Industrial Design and the Future*, by Geoffrey Holme. (Studio Publications Ltd., 1934.)

⁶ *The Conquest of Ugliness*, edited by John de la Valette. (Methuen & Co., 1935.)

⁷ *Art and Industry*, by Herbert Read. (Faber & Faber, 1934. Second edition, 1944.)

⁸ "The Future of Industrial Design," by Herbert Read. A lecture delivered at Burlington House, June 10th, 1943, to the Design and Industries Association.

⁹ *An Enquiry into Industrial Art in England*, by Nikolaus Pevsner. (Cambridge University Press, 1937.)

¹⁰ *Ibid.*, Part II, page 201.

¹¹ *Ibid.*, Part II, pages 201-202.

¹² "The Future of Industrial Design," by Herbert Read.

CHAPTER IX

¹ *The Origin of the Sense of Beauty*, by Felix Clay. (London: Smith, Elder & Co., 1908.) Chapter XI, page 290.

² *Ibid.*, page 291.

³ *Janus in Modern Life*, by Sir William Flinders Petrie. (London: Constable & Co., 1907.)

⁴ *Ibid.*, Chapter II, pages 16-17.

⁵ "Patronage and Art," by Sir Kenneth Clark, *The Sunday Times*, April 2nd, 1944.

SOURCES OF REFERENCES IN THE TEXT

- ⁶ *The Sunday Times*, April 9th, 1944.
- ⁷ *The Sunday Times*, April 16th, 1944.
- ⁸ *The Politics of the Unpolitical*, by Herbert Read. (Routledge, 1943.) *To Hell with Culture* was originally published separately in a series of pamphlets entitled "The Democratic Order." (Kegan Paul, 1941.)
- ⁹ *The Free State*, by D. W. Brogan. (Hamish Hamilton, 1945.) Chapter II, page 93.
- ¹⁰ *The Scientific Attitude*, by C. H. Waddington. (Penguin Books, 1941.) Chapters III and IV.
- ¹¹ "Public Taste and Public Design," by Tom Harrison and D. Behrens. Delivered at Burlington House, May 11th, 1943, to the Design and Industries Association.
- ¹² *Report of the Committee appointed by the Board of Trade under the Chairmanship of Lord Gorell on the Production and Exhibition of Articles of Good Design and Everyday Use.* (H.M. Stationery Office, 1932.) Page 44.
- ¹³ *Modernismus*, by Sir Reginald Blomfield. (Macmillan, 1933.) Chapter IV, "The New Architecture," page 57.
- ¹⁴ *Design in the Cotton Industry.* A Report of H.M. Inspectors on existing conditions in the Industry and the Schools. (London: H.M. Stationery Office, 1929.)
- ¹⁵ *Railway Rides*, page 103.

CHAPTER X

- ¹ *The Village Carpenter*, by Walter Rose. (Cambridge University Press, 1937.) Chapter II, page 18.
- ² "Chemistry in the Service of Man," the Inaugural Address of the President, Dr. E. Frankland Armstrong, to the Royal Society of Arts, November 1st, 1944. *Journal of the Royal Society of Arts*, Volume XCIII, No. 4679.
- ³ "Timber as a Reconstructed Material," by P. Morton Shand. *The Architectural Review*, February, 1936, pages 76-77.
- ⁴ *Ibid.*, page 76.
- ⁵ *Journal of the Royal Society of Arts*, Volume XCIII, No. 4679, page 7.
- ⁶ "Finishes on Cast Iron," by Derek Bridgwater, B.Arch., F.R.I.B.A. *The Official Architect*, Volume VIII, No. 5, May, 1945, page 248.
- ⁷ *Ibid.*
- ⁸ "New Uses for Glass," by Professor W. E. S. Turner. *Journal of the Royal Society of Arts*. Volume XCI, No. 4646, page 228.
- ⁹ "Cast Iron and its Treatment," by W. R. Lethaby. *Journal of the Society of Arts*, February 14th, 1890.

¹⁰ "What is Wrong with Cast Iron?" by M. Hartland Thomas, M.A., F.R.I.B.A. *The Official Architect*. Volume VIII, No. 5, May, 1945, page 238.

¹¹ *The Missing Technician in Industrial Production*, by John Gloag. (George Allen & Unwin Ltd. Second edition, 1945.) Chapter VIII, pages 83-86.

¹² "Light Alloys in Post-War Britain," by E. C. Goldsworthy. *Journal of the Royal Society of Arts*, Volume XCII, No. 4663, pages 234-235.

¹³ *Ibid.*, page 234.

¹⁴ "Materials, Old and New," by E. Frankland Armstrong, F.R.S. *Journal of the Royal Society of Arts*, Volume XC, No. 4608, page 231.

¹⁵ *Craftsmanship and Science*, by Professor Sir William Bragg. (London: Watts & Co., 1928.) Page 18.

¹⁶ *Plastics and Industrial Design*, by John Gloag. (George Allen & Unwin Ltd, 1935.) Chapter V, pages 50-51.

CHAPTER XI

¹ *Furniture and Furnishing*, by John C. Rogers, A.R.I.B.A. (Oxford University Press, 1932.) Section V, page 53.

² *The Evolution of the English House*, by S. O. Addy. (George Allen & Unwin Ltd. Revised and enlarged edition, 1933.) Chapter VI, pages 113-114.

³ George Burton Hotchkiss, Professor of Marketing at New York University, in his introduction to a reprint of *A Treatise of Commerce*, by John Wheeler. (The New York University Press, 1931. Reprinted from the original edition of 1601.) Chapter V, page 26.

⁴ *Samuel Kelly*, the Diary of an Eighteenth Century English Sea Captain. Edited by Crosbie Garstin. (Jonathan Cape, 1925.) Part II, Section II, November 12th, 1789.

⁵ *The Voice of Civilisation: an enquiry into Advertising*, by Denys Thompson. (London: Frederick Muller Ltd., 1944.) *The Economics of Advertising*, by F. P. Bishop. (London: Robert Hale Ltd., 1944.)

⁶ *Advertisement Writing*, by Gilbert Russell. (Ernest Benn Ltd., 1927.) Chapter I, page 26.

⁷ *The Voice of Civilisation*, by Denys Thompson. Chapter III, page 134.

⁸ *Typography*, a book of type specimens. Compiled and largely written by Francis Meynell for the Pelican Press and published during the early nineteen 'twenties.

⁹ "National Design in Printing," by Francis Meynell. Lecture delivered to the Design and Industries Association, April 8th, 1943.

CHAPTER XII

¹ *Vision and Design*, by Roger Fry. (Chatto & Windus. Phoenix Library, 1928.) The essay "Art and Socialism" in this volume was originally published in 1912.

² *The Work, Wealth and Happiness of Mankind*, by H. G. Wells. (William Heinemann, 1932.) Chapter XIV, page 711.

³ *An Enquiry into Industrial Art in England*, by Nikolaus Pevsner. (Cambridge University Press, 1937.) Quoted in Chapter VIII.

⁴ *Memorandum of the Position of the Designer for British Industries after the War*, prepared for the Arts Enquiry by Nikolaus Pevsner. (1943. Unpublished.) Part of paragraph 15 and paragraphs 16 to 22 inclusive have been quoted with the author's permission. The paragraph numbers have been omitted from the quotation.

⁵ *The New Architecture and the Bauhaus*, by Walter Gropius. Translated from the German by P. Morton Shand, with an Introduction by Frank Pick. (Faber & Faber, 1935.)

⁶ "Design for Home and Export," by S. C. Leslie. *Board of Trade Journal*, Volume 151, No. 2520, March 24th, 1945.

A SHORT LIST OF BOOKS ON INDUSTRIAL AND ARCHITECTURAL DESIGN

The books included in this list are not highly technical works; all are easy to read, and they represent various points of view.

ARCHITECTURE

(a) *General*

CHRISTIAN BARMAN

Architecture (Benn's Sixpenny Library).

Balbus, or the Future of Architecture (Kegan Paul).

JOHN BETJEMAN

Ghastly Good Taste (Chapman & Hall).

SIR REGINALD BLOMFIELD

The Mistress Art (Arnold).

DARCY BRADDELL

How to Look at Buildings (Methuen).

ROBERT BYRON

The Appreciation of Architecture (Wishart & Co.).

W. A. EDEN

The Process of Architectural Tradition (Macmillan).

A. TRYSTAN EDWARDS

Architectural Style (Faber & Faber).

Good and Bad Manners in Architecture (John Tiranti).

The Things Which Are Seen (John Tiranti).

MAXWELL FRY

Fine Building (Faber & Faber).

FREDERICK GIBBERD

The Architecture of England (Architectural Press).

JOHN GLOAG

Men and Buildings (Country Life Ltd.).

W. H. GODFREY

Our Building Inheritance (Faber & Faber).

H. S. GOODHART-RENDEL

Vitruvian Nights (Methuen).

WALTER GROPIUS

The New Architecture and the Bauhaus (Faber & Faber).

A SHORT LIST OF BOOKS ON INDUSTRIAL DESIGN

HENRY RUSSELL HITCHCOCK

In the Nature of Materials: 1887-1941, The Buildings of Frank Lloyd Wright (Duell, Sloan & Pearce, New York).

JULIAN LEATHART

Style in Architecture (Nelson).

LE CORBUSIER

Towards a New Architecture (John Rodker).

WILLIAM LESCAZE

On Being an Architect (G. P. Putnam's Sons, New York).

W. R. LETHABY

Architecture (Home University Library).

ROBERT LUTYENS

Sir Edwin Lutyens: an appreciation in perspective (Country Life Ltd.)

NIKOLAUS PEVSNER

An Outline of European Architecture (Penguin Books).

J. M. RICHARDS

An Introduction to Modern Architecture (Penguin Books).

A. E. RICHARDSON and HECTOR O. CORFIATO

The Art of Architecture (English Universities Press Ltd.).

HOWARD ROBERTSON

Architecture Arising (Faber & Faber).

Architecture Explained (Benn).

The Principles of Architectural Composition (Architectural Press).

GEOFFREY SCOTT

The Architecture of Humanism (Constable).

LOUIS H. SULLIVAN

The Autobiography of an Idea (W. W. Norton & Company Inc., New York).

DORA WARE and BETTY BEATTY

A Short Dictionary of Architecture (Allen & Unwin).

C. and A. WILLIAMS-ELLIS

The Pleasures of Architecture (Cape: Life and Letters series).

CLOUGH WILLIAMS-ELLIS and JOHN SUMMERSON

Architecture Here and Now (Nelson).

FRANK LLOYD WRIGHT

Modern Architecture. The Khan lectures for 1930. (Princeton University Press, U.S.A.)

When Democracy Builds (University of Chicago Press).

F. R. S. YORKE and COLIN PENN

A Key to Modern Architecture (Blackie).

INDUSTRIAL ART EXPLAINED

(b) *Domestic*

SIR PATRICK ABERCROMBIE (edited by)
The Book of the Modern House (Hodder & Stoughton).

SIDNEY O. ADDY
Evolution of the English House, revised and enlarged from the
Author's notes, by John Summerson (Allen & Unwin).

CATHERINE BAUER
Modern Housing (Allen & Unwin).

ANTHONY BERTRAM
The House a Machine for Living In (A. & C. Black).

GEOFFREY BOUMPHREY
Your House and Mine (Allen & Unwin).

HUGH BRAUN
The Story of the English House (Batsford).

ELIZABETH DENBY
Europe Re-housed (Allen & Unwin).

JOHN GLOAG
The Englishman's Castle (Eyre & Spottiswoode).

JOHN GLOAG and GREY WORNUM
House Out of Factory (Allen & Unwin).

NATHANIEL LLOYD
A History of the English House (Architectural Press).

RAYMOND MCGRATH
Twentieth Century Houses (Faber & Faber).

R.I.B.A. RECONSTRUCTION COMMITTEE
Rebuilding Britain (Lund Humphries).

J. M. RICHARDS
A Miniature History of the English House (Architectural Press).

F. R. S. YORKE and FREDERICK GIBBERD
The Modern Flat (Architectural Press).

(c) *Public Buildings*

FELIX CLAY
Modern School Buildings (Batsford).

L.C.C. REPORT
Open Air Schools (King).

A. S. MELOY
Theatres and Motion Picture Houses (Batsford).

P. MORTON SHAND
Modern Theatres and Cinemas (Batsford).

A SHORT LIST OF BOOKS ON INDUSTRIAL DESIGN

HOME EQUIPMENT

GEOFFREY BOUMPHREY

The House—Inside and Out (Allen & Unwin).

NOEL CARRINGTON

Design in the Home (Country Life Ltd.).

T. H. ROBSJOHN-GIBBINGS

Goodbye, Mr. Chippendale (Alfred Knopf, New York).

JOHN GLOAG

English Furniture (A. & C. Black: Library of English Art).

PAUL NASH

Room and Book (Soncino Press).

R. RANDALL PHILLIPS

The Servantless House (Country Life Ltd.).

M. and C. H. B. QUENNELL

A History of Everyday Things in England (Batsford).

JOHN C. ROGERS

Furniture and Furnishing (Oxford University Press).

INDUSTRIAL DESIGN AND MATERIALS

GEOFFREY BOUMPHREY

The Story of the Ship (A. & C. Black).

The Story of the Wheel (A. & C. Black).

SIR WILLIAM BRAGG

Craftsmanship and Science (Watts & Co.).

NOEL CARRINGTON

Design and a Changing Civilisation (John Lane).

METIUS CHAPPELL

British Engineers (Collins: Britain in Pictures series).

DESIGN AND INDUSTRIES ASSOCIATION

Four Lectures on Design, delivered by Henry Strauss, M.P., Francis Meynell, Tom Harrisson and Herbert Read, before the D.I.A. (Hutchinson).

SIEGFRIED GIEDION

Space, Time and Architecture (Harvard University Press, U.S.A., Oxford University Press).

INDUSTRIAL ART EXPLAINED

JOHN GLOAG

Artifex, or the Future of Craftsmanship (Kegan Paul).

The Missing Technician in Industrial Production (Allen & Unwin).

Plastics and Industrial Design, with a Section on the properties and uses of the various types of Plastics by Grace Lovat Fraser (Allen & Unwin).

The Place of Glass in Building, edited by John Gloag (Allen & Unwin).

GEOFFREY HOLME

Industrial Design and the Future (Studio Publications).

PHILIP JOHNSON

Machine Art (Allen & Unwin).

RAYMOND McGRATH and A. C. FROST

Glass in Architecture and Decoration: with a Section on the nature and properties of Glass by H. E. Beckett (Architectural Press).

"PLASTES"

Plastics in Industry (Chapman & Hall).

NIKOLAUS PEVSNER

Industrial Art in England (Cambridge University Press).

Pioneers of the Modern Movement, from William Morris to Walter Gropius (Faber & Faber).

HERBERT READ

Art and Industry (Faber & Faber), 2nd edition 1944.

RICHARD SHEPPARD

Cast Iron in Building (Allen & Unwin).

JOHN DE LA VALETTE (editor)

The Conquest of Ugliness (Methuen).

V. E. YARSLEY and E. G. COUZENS

Plastics (Penguin Books), 3rd edition 1944.

GENERAL

CLIVE BELL

Civilisation (Chatto & Windus).

ANTHONY BERTRAM

Design (Penguin Books).

Design in Daily Life (Methuen).

SIR REGINALD BLOMFIELD

Modernismus (Macmillan).

MARGARET BULLEY

Art and Counterfeit (Methuen).

A SHORT LIST OF BOOKS ON INDUSTRIAL DESIGN

V. GORDON CHILDE

Progress and Archaeology (Watts & Co.).

FELIX CLAY

The Origin of the Sense of Beauty (Smith, Elder & Co.).

JOHN HEMMING FRY

The Revolt against Beauty (G. P. Putnam's Sons, New York).

ROGER FRY

Vision and Design (Chatto & Windus).

ERIC GILL

Art and a Changing Civilisation (John Lane).

Beauty Looks after Herself (Sheed & Ward).

JOHN GLOAG (edited by)

Design in Modern Life (Allen & Unwin).

Design in Everyday Life and Things; the Year Book of the Design and Industries Association, 1926-7 (Benn).

JULIAN HUXLEY

T.V.A.: Adventure in Planning (Architectural Press).

F. R. LEAVIS and DENYS THOMPSON

Culture and Environment (Chatto & Windus).

W. R. LETHABY

Form in Civilisation (Oxford University Press).

SIR WILLIAM FLINDERS PETRIE

The Revolutions of Civilisation (Harper).

LISLE MARCH PHILLIPPS

Form and Colour (Duckworth).

The Works of Man (Duckworth).

STEEN EILER RASMUSSEN

London: the Unique City (Cape).

MANNING ROBERTSON

Everyday Architecture (Fisher Unwin).

SIR HUBERT LLEWELLYN SMITH

The Economic Laws of Art Production (Oxford University Press).

JOSEPH THORP

Design in Modern Printing (Benn).

Printing for Business (W. H. Smith).

SIR HENRY TRUEMAN WOOD

A History of the Royal Society of Arts (John Murray).

SELLING THROUGH DESIGN

By RAYMOND LOEWY, Hon.R.D.I.

THE paper reprinted here by permission of Mr. Loewy was read on his behalf by the author, before the Royal Society of Arts, on December 3rd, 1941. The introductory paragraph and some of the concluding sentences have been omitted. The paper, and the discussion that followed it, are published in full in the proceedings of the Society. (*Journal of the Royal Society of Arts*, Vol. XC, No. 2604.)

That the designer has a place in industry is accepted as fact in the United States. It was not always thus. Twenty-one years ago, following the first Great War, Industrial Design as a profession was born. Peak production for war turned overnight into peak production for peace. There was no time for planning. The market was wide open, and the demand was immediate for every sort of manufactured item, no matter what its form. Tremendous building projects were undertaken with little or no considered planning. Products, machines, transportation units were ground out in the greatest surge of mass production the world to that time had ever known. By 1924 it appeared that the market for every conceivable manufactured product had been supplied; the saturation point was reached. From the state of affairs where everyone seemed to need everything, no one seemed to need anything. "Seemed," I say, for, in the years that followed 1924 business men discovered that the market at that juncture was not saturated—it was scarcely humid.

The process of this discovery is coincidental with the history of Industrial Design as a large-scale enterprise. How to revive a glutted market? The business man, in order to open new avenues of expansion, increased the number of models in his line; he initiated high-pressure sales campaigns; and he decided that sale could best be accomplished by changing the appearance of his product to appeal to the aesthetic and civilised taste of the increasingly prosperous customer. So the designer came into the picture; he patched up bad jobs to begin with; the ugliness of the majority of manufactured items was unbelievable. Since very little discrimination had been exercised in the original design, obsolescence was rearing its ugly head. The manufacturer had invested heavily in every phase of manufacture except in the design. Superfluous surface decoration, uninspired colour treatments, design inconsistencies which covered rather than revealed the nature of the object were repeated in every machine-made item.

APPENDIX I

The most flagrant bad taste was to be seen in vast building projects, which were not only badly laid out, but proved to be expensive to maintain and painful to see. Many architectural monstrosities which were intended to endure, presumably, through decades to come, turned out to be eyesores within a few years after their construction. Building projects represent major investments. If we view with a jaundiced eye the design of the 1920's, it is because the basic design was bad unequivocally "in the beginning as it is for ever more." We laugh, and rightly, at women's fashions of a decade or two past, but we know that the designer never had any intention of projecting that fashion beyond a year, a season. To inject modishness into a large-scale design is not only bad Industrial Design, it is expensive and impractical. In the 'twenties designers worked at fever heat to satisfy the screaming demand for more and more buildings, products, vehicles; unfortunately they were not fortified against this unusual activity with plans that had been meticulously developed in slack periods. But the same mistakes will be made again unless we set ourselves to profit by what has been learned over the intervening years.

Four principles have guided the designer early and late—efficiency, simplicity, economy, ease of maintenance. I do not mention beauty since it is a direct result of the combination of simplicity and efficiency. These form the working credo and the philosophy of approach—the Industrial Designer is never tired of expatiating on any of the four to any audience he can corner.

Whenever a product lacks any of these four design requirements it faces probable commercial failure. It must be recognised that the emphasis on one or another of the three requirements varies with the nature of the product. For example, I have designed farm tractors and trucks for International Harvester Company, a bottling inspection machine for Coca Cola, and a line of cosmetic packages and bottles for Elizabeth Arden. In all of these efficiency, simplicity, ease of maintenance, economy, are incorporated in the design, but the function of each demands a different philosophy of approach. The tractors and trucks are designed to dramatise their ruggedness, power, durability; ease of maintenance, efficiency dictate the machine design; and simplicity, feminine sparkle pervades the cosmetic line. In all the talk about "functional" design it must not be forgotten that one of the functions of a product is that it be aesthetically satisfying. Between two products equal in quality, price and function, the one that is aesthetically correct is the one that sells. The Industrial Designer has dedicated himself to educating public taste; it is growing constantly. The cold, uninspiring examples of so-called Functionalism are rebukes to the profession of Industrial Design. Because the Industrial Designer leaned over backwards to prove that he was not a useless, luxury item, occasionally he fell

into a chill, harsh style that deserves as much disfavour as Victorian fustiness. Advertisers talk of "eye appeal," manufacturers of sales and costs, artists of aesthetic values. The designer assumes the attitudes of all three when he works. His record in the past twenty years is a triumph of diplomacy, practicality, invention.

I speak not only for the work that is done in my organisation. Naturally, being closest to my own problem, I can speak of it with better authority. But I want to say a word, here and now, for the creditable work of other Industrial Designers . . . men who have pioneered in the field of Industrial Design and who have created or fostered a public taste that demands an increasingly high standard of design and engineering perfection. It is not possible to take the attitude, as it has been taken on occasion, that the public can be fooled always, and that a bad design will be as popular in a highly competitive market as a good one. This is not true, and sales records are the best proof of this.

Of course, no designer can claim entire credit for the sales success of a product on which he has worked. There are too many other agencies involved. Advertising, publicity, the prestige of a name associated for years with integrity and enterprise—with all of these the designer shares credit for the eventual outcome. Design, however, pays its way. The figures I quote as factual evidence have been sent me voluntarily by several of my clients.

In 1941 it is estimated that approximately \$850,000,000 worth of manufactured goods and operations will appear according to design specifications marked "Raymond Loewy," and I present this as an indication of the scope of an Industrial Designer's present activities in American business. For General Motors I design the complete line of Frigidaire products—ranges and refrigerators, and whenever I say "I design" I wish it to be understood "in collaboration with the very capable engineers of my client companies." In 1940 an increase of 100,000 units sold—i.e. 25 per cent more than the previous year—is attributable in part to design, and this for a product which has been a leader in the field for years. Studebaker's increase in sales of about 128 per cent from 1938 to 1940 coincides with my retention by that corporation. An unsolicited letter from Pennsylvania Railroad, for whom I design rolling equipment as well as stations, ticket and business offices, testifies that rental values have increased as the direct result of extensive modernisation in their New York Station. One space, originally occupied by a barber shop and a toy shop, commands 800 per cent more rent since its reconstruction. Another area has risen 130 per cent in rental value since its re-design; and still another 54 per cent. Besides increasing the values of existing areas use has been made of hitherto unused space.

The modernisation of the Pennsylvania Station is one in many

APPENDIX I

examples of expensive construction which is designed carefully to defeat quick obsolescence and to increase the immediate revenue. Store modernisation and store design have proven their value in paving the way for modern merchandising methods. For Lord & Taylor I have just completed a new suburban store—their first out of the city—to supplement their large city unit. About \$3,500 per day was the sales expectancy; since opening the store has averaged over \$10,000 per day. This unusual store design incorporated many innovations which had proven successful in some of my previous department store construction projects. Grant's, a chain store series for the mass sale of inexpensive items made store history with a convertible window display and selling unit. The principle of "contagious selling" was initiated here, proving that the sight of customers in the process of buying was the best way of inducing potential customers to enter the store. No barrier at the back of the display window opening separates merchandise from potential buyer. The buying virtually takes place on the sidewalks. Bargain counters are placed just inside the window, and the spectacle of the buying rush is contagious, creating a "consumers' suction" inside the store. Another store—Macy's Parkchester unit—was opened on October 13th and has already been expanded in several departments. In the original design space was provided for just such an eventuality.

It is not the purpose of this discourse to present a comprehensive survey of my activities. In the present world situation I am much more interested in and concerned with the future that lies ahead for the designer and the manufacturer. One point should be impressed, I think; that the full possibilities of design have not been realised. The fact that a major portion of my work at present is architectural in nature indicates a trend towards co-ordinating all the facets of design activity. For too long it has been assumed erroneously that the Industrial Designer is a designer of products and of products alone. The publicity that designers have received is largely responsible. It made a better story that someone had "streamlined" a common, garden variety ashcan than that a man had re-designed a machine to increase its efficiency and simplicity in a plant where visitors would seldom be admitted. The ashcan could be photographed—preferably with several attractive young women, clad principally in wreaths of smiles—and newspapers and magazines would print it. The public is only now beginning to realise that a change in the face of the world—imperceptible while occurring, startling in retrospect—is due, in a large part, to the unceasing efforts of manufacturer and designer working on a long-range schedule to improve every visible accessory to living.

The case of the Pennsylvania Railroad is a perfect example of the inter-relation of one field of design to another. Their first "streamlined" locomotive was—it can be claimed without reserve—a com-

plete success. Almost immediately it was decided to re-design coaches, sleeping cars, lounges, diners—with equally gratifying results. Passenger traffic on a particular run increased 37 per cent over the previous average within a year after the introduction of the new train. Public prestige increased for the company; this alone is worth millions of dollars to the management. Little by little the railroad company started the complete modernisation of all its equipment. Ancient, wooden stations were anachronisms in comparison with the modern trains. The transfer from the design of rolling equipment to stationary units of the system was natural. Pennsylvania Station itself underwent a “face-lifting,” with the result already noted. Then it became apparent that smaller stations needed replacement along the track system. For these smaller units I developed a type of pre-fabricated structure which can be constructed in series and moved to the desired location by rail, completely assembled. The flexibility and economy incorporated in this method of construction is a contribution of the designer. His experience in connection with many types of problems gives him an advantage which he passes on to each new client. Again, for Pennsylvania Railroad, an extensive modernisation of all their city ticket offices has been launched. In all these assignments product design is only a subsidiary of the overall design. All fixtures, furniture, silverware, fabrics, display stands, floor coverings are special product designs for the whole. These are no longer classed individually, but are included in a project which is noted as “a design”—singular! In the design of ocean liners the same thing applies. While claiming to be only an engineer and a designer by training, I find that more and more a designer is all things. His work is allied to that of a naval architect, a decorator, a psychologist, an artist, a typographer, a mechanical engineer, an electrical engineer, an authority on aero-dynamics, a chemist, a physicist, an expert in merchandising, a salesman, and, with all, a business man. It is as a business man that the designer faces the future confidently.

A complete cycle is drawing to a close at this very time. The peak production following the last war gave rise to the profession of Industrial Design; we are approaching a similar peak again. But this time the designer brings to bear his weight of experience and a physical set-up in his organisation that can accommodate itself to the volume of activity that is beginning. An economic revolution impends that will involve the whole world; as never before the designer must be an economist. Not for nothing has my organisation survived a depression, a reconstruction and a period of prosperity. Of the three it was the period of prosperity that was most threatening. In an era of extravagant taste it became necessary for some designers to compromise their aesthetic opinions in order to satisfy public demand for more and more *de luxe* models. High taxes, reduced

APPENDIX I

buying power will stabilise consumer demand, and design will be cleaner, simpler, "closer to the bone."

Foreseeing this, the designer is at present engaged in mapping out a programme for design at long range. Emergency has upset, temporarily, the tempo of normal activity; a year-to-year plan is no longer adequate; the pace is at the same time accelerated and retarded. There is no constant flow of business activity. On the one hand, the designer must condense into three weeks what work would ordinarily have been distributed over three months; on the other hand his organisation's operation must move slowly ahead in preparation for the second armistice day and the unprecedented need for immediate reconstruction that will ensue. The designer is gathering his forces for the next post-war period of peak production.

It is not enough to prove that design is a potent selling force. I class design as something more than the "eye appeal" which advertising stresses. A good design will open up new markets, but it must progressively sustain that market for re-sale; more than "eye appeal" is involved in this feat. The day when materials were available in unlimited quantities is over for the time being—manufacture in all fields is adjusting itself to the present emergency.

Just how this emergency is affecting design is a moot question. The matter of conserving materials which are necessary to the defence and aid-to-Britain programmes in this country reposes a responsibility on the conscientious designer. In the normal process of design, research has ever been a great part of the evolution to the finished product. New methods of procedure, new uses and combinations of materials for design in manufacture have accrued to the benefit of both design and manufacture. The conspicuous incorporation of materials such as aluminium, chromium, stainless steel, and within the last seven or eight years of that prodigious family of chemical products, plastics, is the result of the designer's ingenuity in realising the flexibility of these resources. Just as the use of these materials affected the appearance of objects and buildings in common use, so the lack of them will produce a similar revolution in the appearance of things about us. After the steam roller of defence demands has passed over industry, the designer must exercise a greater degree of inventiveness than ever before.

But the very lack of available materials is having an astringent effect on design. By being forced, for instance, to use a cheaper, less malleable substance than aluminium, the manufacturer and designer are taking time to develop and simplify abandoned processes which, in the past, they have discarded as too complicated. Glass, which cannot be surpassed for sheer beauty, will take on forms which have not been deemed practical to attempt. Instead of chromium plating, the designer is finding ways to substitute paint or plastic finishes. For fear of upsetting the order of a commercial

scheme, designers in the past have not dared to insist on imposing their aesthetic standards upon the public. Because the designer is required to do just this at present, the public is already welcoming the simpler cleaner product that is available.

Ultimately, then, design will benefit by the present emergency. The designer, prepared as he is to handle all phases of the large problem ahead, knows that the very conservation of materials now means the freeing of them in tremendous quantities eventually. If design in all manufacture is organised in advance, there is no reason why the eventual flooding of markets should prove a detriment to future manufacture. On the contrary, all designs for that day are being prepared in order to use most specifically those materials which will be available in the greatest quantities. So the designer is operating with a "split personality" in a *dual rôle*. He is co-ordinating the various fields of his endeavour so that each type of design may benefit; he is working quickly, efficiently, to produce in a state of unlimited emergency, while at the same time he is preparing a ten-year schedule for good design when all materials are plentiful; above all, by pre-determining trends in public taste and by setting his aesthetic taste at its highest level, he will produce the most beautiful accessories to living ever available to any civilisation.

Several definite trends in American manufacture directly affect the nature of design in the years to come. Of these the most significant is the tendency to reduce the number of models in any given line of products. Production will be condensed to concentrate every facility for selling on a single, perfect unit. Many design abortions will be automatically disposed of in this action. The extravagance of American design has been the result of adding to a simple entity the *de luxe* features to which the American public has become accustomed. Another trend which is affecting design through business is the increasing danger—to the large manufacturing corporations—of Government operation. In order that private industry may avoid such an eventuality it must demonstrate clearly to the public that no other set-up could possibly do a better job than private enterprise.

Distinctive design at minimum cost, reflecting imagination and taste, is the best, single advantage that private industry has over Government-manufactured products. By designing now for days of peace the designer is preparing with industry for the immediate economical conversion of plant activities into peace-time efforts. Considering the public funds that are being poured into industries for manufacture in time of war, private industry can and should be better equipped than ever before to operate independently. With the variety of products reduced and the facilities for manufacture increased, the designer is called upon to double his administrative and creative efforts.

I know that a designer can do this—and in every field where his

APPENDIX I

experience has proven him capable. The revolution that faces design is only another in the series that has marked the course of its professional history. The designer is a nimble creature and a dependable one. Flexibility is his most valuable asset. The best proof of this would be an examination of the various contract bases under which my organisation works. For American Tobacco I am commissioned to repackage the familiar Lucky Strike package—not in one step, but progressively, so that the improvement in the design will be gradual in order to avoid loss of identity. Here the designer is called upon to satisfy the taste of the established consumer as well as to prove that improvement will increase the sale to the undecided smoker. American Tobacco thinks I can do it. The Frigidaire contract has been extended for the next three years. Here I am to continue the development of their line of ranges and refrigerators in accordance with General Motors policy and the changing public demand. Studebaker also retains me on a long-term basis in order to insure a continuity of its automobile design; individuality in automobile design is a valuable asset, and sales records are proof of this. Holiday and seasonal packaging assignments are accomplished in as little time as six weeks, and are covered by straight fees. In these arrangements the designer must be able to turn out as many as twenty or thirty original designs. It is a matter of pride that many of these short-term contracts lead to contracts of a more permanent nature. Pepsodent, for instance, gave me the job of repackaging their entire line after the complete success of one such temporary assignment. They have realised that continuing the same quality of design, throughout the line is a potent instrument of merchandising. The royalty basis for agreement with certain manufacturers is a welcome form of contract in my office. When royalties are paid above a certain production level I am able to judge with irrefutable accuracy the success of a design with the buying public.

Because design is a sales stimulant it can never be completely dissociated from its commercial aspects. No Industrial Designer will claim that he creates, as an artist does, to satisfy only his aesthetic sense. If he is to stay in business he must develop his scope, his knowledge of materials and processes so that this aesthetic sense will never have to give way to pure commercialism. He will always find a clever way to express himself.

It has become apparent that design, in order to remain useful commercially, must be universal aesthetically. Progressive English designers admit that the domestic quality of some of their designs has closed many markets to English manufacture. The quality of English manufacture is unsurpassed; no designer has the right to handicap a product by restricting its sale in foreign markets simply because an international character is lacking. The same condition exists in other countries. I am touring the South American continent

at present—not as a mere “goodwill” emissary but with the intention of finding a suitable location for a branch office. It is my belief that the United States is a vast untapped market for manufactured items from South America. But the North American taste is such that many products require re-design before they can be sold. Incidentally, this conception is in complete accord with the United States Government’s “good neighbour policy,” as it tends to accelerate continental interdependency.

England will have a larger market in the Americas if the design is suitable. Consumers in the United States have cultivated a degree of sophistication in regard to surface finishes that might well be exploited in other countries. Manufacture abroad should demand of its designers greater ingenuity in using painting, plating, baking processes to enhance the appearance and practicality of manufactured items. Colour psychology needs to be considered more thoroughly in all design. Far too many models of a given product, representing effort which might have been better spent on the development of a single superlative item, have cluttered the English market and the American market alike. The trend away from this dispersion of energies is one I cannot impress too forcibly.

In closing, I beg the indulgence of the august members of the Society if I have unwittingly trod on any toes. I am an American: Americans are admittedly enthusiastic, self-confident. We are imbued with the conviction that our attitude of success is largely responsible for our actual success, and we are not ashamed to say so. We are confident of the victory of Britain over her enemies; we are planning in the laboratory and the office for the day of peace. We know we are right as England is right; we reject any suspicion of industrial or political defeatism. We are proud of our enthusiasm and thrive in it, even if we are not infrequently regarded as ill-mannered children. The American designer, in his innocence, is proceeding with customary exuberance to plan for the production programme of the next ten years. This time industry will have a partner in Industrial Design that is a veteran of many kinds of wars—economic, industrial and political. Designing has grown up to sell.

MATERIALS AND DESIGN

By M. HARTLAND THOMAS, M.A., F.R.I.B.A.

THE influence of materials upon the ideas of designers, both industrial and architectural, has been discussed in some sections of this book. The character and capacity of materials used in building have for centuries commanded the attention of architects. The manner in which contemporary architects approach the study of materials has considerable significance for the industrial designer, and one of the ablest surveys of the impact of new materials and new constructional methods on the nature of architectural design, and on the ideas of architects, was made in a paper read at a meeting arranged by the Architectural Science Board, at the Royal Institute of British Architects, on February 12th, 1944. Some extracts are quoted here, by permission of the author, and the entire paper is reprinted in the *Journal of The Royal Institute of British Architects*, Vol. 51, Third Series, No. 5.

The paper was entitled: "The Influence of New Developments in Construction on Architectural Design," and was by Mr. M. Hartland Thomas, M.A., F.R.I.B.A. The opening paragraphs, which are omitted, referred to the relationship between architecture and science, and after mentioning the importance of an architect being sufficiently acquainted with the branches of science concerned in his design to be able to explain his needs to the appropriate experts and to comprehend their advice, Mr. Hartland Thomas said:

There are some who fear, and rightly, that the present emphasis upon teamwork in design, and upon the architect's function as the co-ordinator of experts, might lead to the disintegration of architecture into its component parts. It is not our purpose to assist in such a disintegration. Admitted that the time has passed, and long passed, when one man, however brilliant, could carry in his own person sufficient knowledge to produce good architecture unaided. But the importance of the artistic conception persists. Indeed, the artistic conception, the vision of a building project in its entirety, as a whole, is unavoidable. It must be seen as a single idea by somebody at some stage in the work. It is the concern of architecture that the vision should be seen early, seen clearly, and seen whole. It is our concern to contribute something to the mental equipment of those upon the rightness of whose vision so much depends.

There are few architects who would not admit the need among us for a deeper understanding of the true function of the component

parts of a building. Only thus can the development of architectural form be released from mere convention—falsely sometimes called “scholarship”—on the one hand, or protected from the assaults of fashion on the other.

Negative evidence for the existence of fundamental thinking at the back of a design can be provided by the absence of derivative or carried-over forms. Conscious imitation is not meant, such as the lining-out of plaster to simulate masonry, or the surfacing of asbestocement by some photographic process in reproduction of oak. It is the unconscious inability to think in terms of the new material or the new problem, so that the habitual appearance is carried over into the new conditions. The history of architecture offers many instances of this weakness in human ingenuity, and, such is the facility with which artistic refinement can reduce appearances to our liking, the resultant forms are often held in high esteem.

An early instance of carried-over form is the Egyptian reeded column, in which the stonework retains the form of the bundles of reeds that preceded it.

The most famous of all is, of course, the Greek Order, which clearly exhibits in marble its derivation from timber construction, modified by the addition of terra-cotta dressings, before translation into stone. This is not to say that appropriate changes were not made at the transitions. For one thing, the shortening of lintel spans was unavoidable. And refinements were introduced—both optical, such as the use of fluting to make cylindrical surfaces more clearly identifiable; and emotional refinements, such as the choice of profiles according to their position and the imagined work that they were called upon to perform. Indeed, it is admitted that the Classical Orders had already in the fifth century B.C. attained a perfection of form never since equalled in the design of the Orders, still less surpassed. Can it be that, if the Athenian architects had first gone to school in Ionia, where experimental science was then being born in the liberal climate of the Greek colonies, before expending their brilliant ingenuity upon the perfection of obsolete forms; then the subsequent history of Classical Architecture might have been one of sustained and orderly progress, instead of many centuries of repeated imitations never attaining again to the original perfection of Athens?

The carry-over of architectural form in the Greek Orders was largely influenced by religious considerations as the most elaborate buildings in the Golden Age were the temples. It was felt that if the new temple was too unlike the old, the god would not recognise it and return to dwell there again at the reconsecration. A not dissimilar emotion persists to this day in the preference for the Gothic arch for religious buildings, no matter how unsuitable the material, as in the windows of many a corrugated iron mission church, or

APPENDIX II

the location, as in the wilds of a tropical jungle, or the recent R.A.F. chapel in North Africa.

Modern instances of this tendency to carry over old forms into a new situation confront us on all sides. The multiplication of minor examples is perhaps more illuminating than a sketch of broader tendencies. An instance often noticed is the misuse of rusticated stonework for the casing of a steel structure. In massive walls there was a risk of the edges of the ashlar blocks spalling off in the lower courses. This was prevented by chamfering those edges. Such chamfering also served the purpose of emphasising the size and thickness of the stones, so that this and other forms of rustication came to be the accepted treatment for the bottom storey of a massive building. To carry this treatment over to stonework that is mere facing to steel was either thoughtless, or a deliberate falsification.

But it is important not to be hasty in ascribing an apparent carry-over to mere copyism. For example, the grooving out of granolithic paving in small squares, which appears to imitate stone setts, has two reasons appertaining to the newer material. One is to release the surface tension to avoid cracks, the other to prevent slipping.

A type of carry-over that is common is where the newer material has no particular shape, owing to the exigencies of the material itself, and is so tractable that almost any modelling can be imparted to it. Cast iron is one of these. In the last century iron masqueraded as wood trellage, ropework, logs with the bark on, masonry, and many others; so that modern designers pass over in contempt what is by nature an excellent and versatile material.

Coming nearer to the present time, one notices the meagre size of the panes in standard steel sash, and of the panels in standardised tea-shop style plywood panelling. The meagre proportions are a carry-over from the limitations of the previous material.

The tendency to carry over is by no means confined to matters of architectural form in the restricted sense. It also appears in structural practice. For instance, the almost universal provision of a slight fall to asphalt flat roofs. There is not the least need for this, and the grading is an addition in labour and materials. The asphalt, indeed, would be better preserved for a little water standing on it. The slope is a carry-over from sheet metal construction.

A fairly common method of wall construction is reinforced concrete frame with brick in-filling to the panels. This is not a logical way of using moulded concrete, which so easily runs in broad masses of continuous walling, doing duty here as pillar, there as beam, and elsewhere merely as weather protection. The unnatural restriction of concrete into posts and beams of small section is a carry-over from steel frame with brick in-filling.

A very recent example is the compilation of tables of properties for standard sections in aluminium alloy. These sections are to be

of the same shapes as those already in use for steel, although the newer metal with its different physical properties—such as a lower modulus of elasticity—demands a new range of sections proper to itself.

Another not so recent example comes from the early welded steel multi-storey framed buildings. It is customary in riveted construction to change the section of a stanchion at a few feet above the floor level, so as to avoid the complexity that would result if the cover plates to the stanchion and the bearings of the girders occurred together. This position for the change of stanchion section, with its awkwardness for internal finishes, was unthinkably maintained in the early welded versions. In later examples, the change occurs where it should, at the level of the floor girders.

To move on to an example where the architect probably had no part in the definition of the form of the new invention, consider the electric light bulb. The choice of a point source for the emission of electric light gave birth to a whole industry whose sole function has been the attempted rectification of that original error. The intolerable brilliance of the filament concentrated at a point has had to be masked, reflected, shaded, filtered, concealed—half a century of lost efficiency and elaborate botching, which is only now drawing to a close with the recent introduction of the fluorescent tube: and all because the inventive engineer could only think in terms of artificial light sources that had gone before him—the individual flame from candle, lamp and gas-jet.

This tendency to carry over forms after they have lost their meaning is, as will have appeared from the last example, by no means confined to architecture. To go further afield, take an ordinary table spoon. Many generations ago the manual craftsman used to make the bowl and the handle separately, and then to braze the two together. Nowadays they are stamped or moulded in one piece, but on nine out of ten you will still find the rat's tail on the back of the bowl which used to effect the junction between the two.

We architects are often advised to take as our models for functional design the products of the mechanical engineer. But what do we see? Why is the engine of the automobile placed at the front, in spite of all the problems in transmission of power to the driving wheels at the back? It is not there, as some argue, to keep the driver's toes warm, nor as a shock absorber when he encounters a lamp-post. The motor-car is still the "horseless carriage," as it was dubbed at its introduction; the ghost of a horse still trots in front of the driver, who, to prove it, measures the capacity of his mechanical ghost-horse in terms of "horse-power."

The railway coach shows a similar carry-over. We are accustomed to the queer little compartments each with its separate door, and take them for granted. But who, confronted with an empty shell

APPENDIX II

of a coach, would subdivide it for seating in such a curious manner? Reference to early railway prints supplies the explanation. There we find on the first coaches a painted line on the outside in a series of sagging curves, marking off each compartment at the bottom to a shape reminiscent of the curved underside of the old stage coach. It is, of course, a carry-over. We rub knees in our cramped compartments because Pickwick rode that way. It is a wonder we are not still expected to clamber up on to the roof when it is full inside!

Enough has been said to indicate that this tendency to carry over obsolete forms is not the peculiar shame of architecture, but a widely-spread weakness of man's invention. It is often due to superstition, or else to conservatism (which is a compound of superstition and lethargy), but most of all to the difficulty of fundamental logic which is a very real barrier to the attainment of clarity in design. Every designer who has made the attempt to discard habitual forms and to solve a problem from the logic of the situation alone, knows well how easily his pencil runs along the well-worn lines. That is the easy way; and unfortunately, it is made still easier by the resources of modern technique. There is always a material or a technique available to make a passable construction out of an ill-conceived design. For instance, there is scarcely any limit to the loads and spans attainable in steel construction, but it is quite another matter to make exactly the right demands upon the steel constructor. It is not enough for architects to sit back and accept the results of science like ripe plums falling in our laps. We must ourselves acquire enough of the scientific outlook, and become sufficiently well acquainted with the theories and experiments that lie behind the results, to assess the value to architecture of the many different products and methods that are presented to our notice. Unless we do this, there is always the risk of taking one aspect of science and running it for a short time as an architectural craze, just because somebody of great knowledge and persuasiveness read a paper on that subject to the Royal Institution, and its novelty took us all by storm. Usually it is something that should not have been new to us at all. An instance of this was the craze a few years ago for insolation. The architectural press was at that time replete with elaborate diagrams and machinery for measuring the number of hours per day during which the sun might, if not obscured by cloud, shine into a particular window, and how far it would strike into the room; sunshine was for a time the main factor in the design of every house; and the craze ran on until the term "sun-trap" was added to the vocabulary of house-agent's English.

Just as crazes are bad in the profession at large, so the individual architect has no business to specialise in any one branch of science to the exclusion of the others; or rather, he abdicates from the function as an architect if he does.

It is with these considerations in mind that the Architectural Science Board embarked upon a very wide course of subjects for these lectures. Some of the subjects so far attempted have been Soil Mechanics, Lighting (natural and artificial), Weathering, Ventilation, Hygiene, Heating, Sound Transmission. The method of dealing with each subject that is asked of the lecturers in conference beforehand is first to give a broad impression of the present state of knowledge on their subject, second to pack in as much hard fact and illuminating illustration as will go, and third to give some simple rules and approximations for rapid use at the sketch design stage. The subjects dealt with in this manner have been diverse, but they all have their bearing upon architecture and each contributes towards a deeper conception of the art. After those that have a general bearing on design, although the list of possible titles has by no means been exhausted and will be returned to later, we have turned in the present series to subjects that have a more direct bearing upon the construction of buildings. These have been concerned with the three main materials for constructing the skeleton of a building—timber, metal, and reinforced concrete—and are well suited to prompt some broad reflections upon the influence of science upon architecture, and structural invention upon architectural form.

These three methods of construction are, as we have seen from the three lectures that we have attended in this series, approaching a similarity of form that should be particularly acceptable to architects—the architect's function being to conceive the building project as a whole in all its implications—for we now find that structural theory is coming to meet him half way, in offering structures that are primarily conceived as a whole, rather than as the sum of separately calculated parts. Let us summarise the three lectures from this point of view.

Mr. Reece, in his lecture on New Developments in Timber Construction, paid us the compliment of presenting a closely-reasoned theoretical analysis leading up to conclusions of more immediate utility to the architect. The clarity of his explanation was so illuminating that an understanding of the inner behaviour of timber under conditions of strain can now become part of the architect's mental equipment. It would not have been so valuable had he merely listed the new developments, such as Stress Grading, Laminated Construction, Ring Connectors, Adhesives, and the rest, given a few figures for working stresses and ended with a run of pictures showing examples of recent structures employing the new methods. That would have been a superficial approach, which does not really meet the architect's needs. The list of new developments, and the illustrations of recent uses, would merely have whetted his appetite, and might have prompted inappropriate applications of the new methods owing to imperfect understanding. As for a table of working

stresses, these belong to the detailed checking of a design, and not to the original conception of it, which is the highest function of design. The analytical knowledge presented in Mr. Reece's lecture, when fully assimilated, can become part of the unconscious mental background of architectural design in timber. For the details I must refer you to his lecture, which will be published, but here is a synopsis.

(The lecture referred to was by Mr. Philip O. Reece, A.M.Inst. C.E., A.M.Inst.M. & Cy.E. and was entitled: "Recent Experiences in the Design of Timber Structures." It is published in full in the *Journal of the R.I.B.A.*, Vol. 51. Third Series, No. 5. Pp. 118-126.)

Timber, though one of the oldest of materials for the craftsman, is, owing to the lateness of its scientific analysis, one of the newest in potentiality. A comparison of strength-weight ratios (which are a useful avenue leading to strength-cost assessments) between timber, metals and plastics, shows timber best in flexural rigidity (that is, for all components lightly loaded in relation to size—slender columns, long beams, stressed skin construction), stronger than steel in tension, weak in shear, and, as plywood with a plastic adhesive, good in compression, and best of all again in bending. This analysis confirms most of the traditional uses of timber, except that members have tended to be larger than necessary, and, more significant, the use of timber struts but steel ties in a truss is a reversal of their respective best properties.

Two reasons for this reversal are given—knots which, hitherto unpredictably, diminish tensile strength, and joints which are made by cutting away part of the member's cross-section. These two faults of timber construction can now be overcome by stress grading, which by statistical method gives quantitative values to qualitative judgments upon samples from a batch; by laminated construction which allows the average instead of the lowest strength to dictate the working stress; and by the use of the new and stable adhesives, together with the inter-surface connectors, to design joints that develop the full strength of the member.

The use of the plastic adhesives means to timber construction what welding means to steel construction, namely, the possibility of rigid frame or one-piece construction—whether it be the laminated arch, or the plywood box girder with rigidly connected uprights, or the stressed skin of the Mosquito wing.

The "Redux" adhesive, not long released from the secret list by the Ministry of Aircraft Production, which can join metals to timber, as well as to metal, by specific adhesion, points the way towards the design of composite one-piece structures in which metals, timber and plastics are combined, with each in its most advantageous situation.

Mr. Moon's lecture on Welded Steel Structure followed a different

pattern. The research work upon welding is not recent, as with timber, but was elaborated many years ago. The reason why welded structures are not common in this country is that their use has been deliberately stifled by a price ring (reminiscent of Breakages, Ltd., in Mr. Bernard Shaw's play *The Apple Cart*) designed to maintain in use the capital equipment already established for riveting. The stress of war has forced the adoption of the more economical method for war production, and it is hoped that the many thousands of trained welders available after the war will exert sufficient pressure for their skill to be employed.

Mr. Moon began by stating that a weld is the natural method for joining metals, and instanced the wedding ring, which is welded by hammering. Continuity of homogeneous material is the characteristic of a weld, so that the welded structure becomes one piece of metal. The rigid framework is economical (some 20 per cent of weight is saved), and it expresses the inherent character of steel, which is first of all strength, and furthermore, strength with lightness and slenderness. Welding develops the full allowable load to best advantage—if one part is overstressed the stresses tend to redistribute themselves—with the result that the peculiar character of steelwork is most clearly brought out by welding.

This emphasis upon the "character" of the welded construction was a marked feature of the commentary upon a very ample series of illustrations. The intellectual and aesthetic satisfaction that welded construction affords the designer is a strong recommendation for the addition of the welded method to the architect's vocabulary.

Much encouragement was given to any architect desirous of making the attempt to think in terms of welded frame, by the story of a small structure shaped as half a decagon (or a Mansard roof on posts), in which the original choice of steel section by the simple graphical method of the load line parabola was confirmed by four subsequent analyses in ascending order of complexity. Mr. Moon gave other useful approximations for the sketch-design stage, and revealing explanations of technique, for which reference should be made to the published version of his address.

The examples shown ranged from multi-storey structures, in which advantage was taken of the savings effected by continuity of girders and stanchions, to two-pin and three-pin arches of small and large loading and span, and to north-light and monitor-type tree-form structures, and ended with a series of bridges of arched or girder, or mixed arch and girder, shape, in which last the magnitude of the structure compels, as it so often does, a faithful presentation of the essential possibilities of the material and method employed.

One particular bridge had evoked a comment which has great significance. It was a two-pin frame with legs sloping outwards, in

the form of approximately three sides of an octagon, so that its classification would be partly a girder and partly an arch. The cleanness of the welded platework and the evident rightness of the tapered legs, and of the disposition of material generally, so impressed an experienced craftsman that he exclaimed that it gave him the same feeling as did the interior of a vaulted cathedral. In both cases the unity of the structure and the rightness of the form can impress the beholder with a satisfaction that is at the same time intellectual and emotional.

Mr. Parry's lecture is too recently in our minds to require more than a short synopsis. The possibilities of reinforced concrete for monolithic design are a commonplace, but it is not so well understood that the design of the form-work is a master factor. We used to be told that reinforced concrete is a "plastic" material, in the sense that it can be moulded to any shape. So it may be, but the timber and steel used for the moulds are rigid, and if the would-be designer of reinforced concrete could be persuaded to think in terms of form-work, he would come much nearer to using this material in its appropriate fashion.

The most important characteristic of design arising from the best use of form-work is simplicity and continuity of line or pattern. Special shapes were said to be easy to make provided they run in the direction of repetition, and not against it.

The monolithic character of the material is further emphasised by Mr. Parry's insistence upon the rhythm and continuity of operations—whole columns and walls should be poured in one operation; the use of sliding forms was significantly described as, in effect, fabrication by extrusion. His deprecation of imitation finishes, and of subsequent working of the surfaces by chemical applications, hammering or rendering; and his recommendation of surfaces straight from the mould, after attention to clean joints between lifts and a good face, remind us that reinforced concrete is a material that merits respectful understanding of its possibilities by the designer.

There emerges from the consideration of these three materials, Timber, Metal and Concrete, in their present stage of development, a suggestion of the unity of structural form. That unity is, of course, a fact of nature, but the fortunate situation at the present time is that the current technique of structural method serves to bring out that unity, instead of to obscure it. Rigidly framed structures are total structures, imagined from the first as coherent wholes, rather than by the laborious juxtaposition of many component parts. One is no longer to think in terms of stanchion plus beam, or pier plus roof truss, or wall plus floor (each being separately calculated), but to return to a conception of building that is in some ways primitives and imagine the whole structure as one piece, as did the builder,

who in the past might have used the simple cruck for pillar and roof-tree combined.

In presenting some conclusions about truth and humanism in architecture, Mr. Hartland Thomas said:

Truth in architecture is not merely a matter of approving one form of arch as "true," not even the parabolic, and condemning others as false; nor yet is it mere frankness of structure, achieved by exposed steelwork or unceiled timber roofs. Nor, again, is it the narrow interpretation that its critics used to lay upon Functionalism, as if the meticulous assessment of all the "practical" factors in a design could automatically dictate the solution. Practical considerations must, of course, have their place, or the design does not begin to qualify at all; but the rightness of a design needs to be readily understood—and felt.

If the exigencies of structure do not require one form more than another, then the refinement of shape follows the demands of emotion. The distinction in Greek mouldings between the upright wave for the crowning mould, and the reversed wave for the supporting mould, is an example where the emotional understanding of the situation takes command, for there would be no serious risk of the marble spalling off if the upright wave were worked in the supporting position, but that would feel wrong to the eye.

On the other hand, when the demands of the eye are in conflict with the proprieties of structure, then the eye must be taught by the mind. The eye must learn, for example, that the sagging line of a fish-belly girder is not weaker, but stronger for its greater depth where the bending stress is greater. In the same way, a two-pin arch should be deep at the supports, shallow around the points of contraflexure, and deep again in the centre. It is an offence against the intellect, and bad education for the understanding eye, to smooth away that undulating profile, which should be characteristic of the two-pin structure, out of deference to a preconceived aesthetic.

But why, it will be asked, is this of importance? May we not let taste be the final arbiter, provided that stability and convenience have had their due? It is because architecture has a contribution to make to man's realisation of his environment. Architecture can surround civilised man, as it does today, in a world of shams, deadening his susceptibility of intellect and feeling; or it can give him enclosures that portray the forces of nature in a manner that his mind and spirit can apprehend. The distinction between intellect and emotion is very largely one of verbal convenience. One has heard mathematicians exclaim upon the beauty of an abstract proposition. So it is not out of place to demand that a work of art should seek intellectual and emotional justification at the same time. Truth in architecture, the true functionalism founded upon scientific understanding, can provide the much-needed intellectual back-bone

APPENDIX II

to aesthetics. It removes aesthetic understanding from the exclusive province of the aesthete, and makes Everyman a participator. For the answer to the question "Does it work?" can be given to any man who knows how to tinker with his motor-bike; and to go on to the question "Does it look as if it works?" is no very hard step to take. But it is a step of supreme importance, for there is the Architecture of Humanism—an architecture within the comprehension of the ordinary man who is able to understand its simpler message to him, but at the same time an architecture that at higher levels of understanding admits of limitless intellectual analysis and emotional refinement—and, most of all, has the potentiality of achievement more splendid than anything that has gone before. The welding craftsman, who felt himself to be in the same line of tradition as the cathedral builders of the past, voices clearly a latent demand for the true Architecture of Humanism, and warns us to stop our ears to the demands of the pedants and the aesthetes who claim to speak in the name of Humanism.

Among the pedants is the art historian. He has been arguing for the return, in the name of Humanism, to adventitious ornament in architecture. It is not a disinterested appeal. It is from the convenient labels afforded by ornament that the insensitive pigeon-holing mind can catalogue the exhibits in his museum, and lead round the parties of reluctant school-children, telling them that the dog's-tooth is "Norman," but the strap-ornament is "Tudor." Unless modern architecture is to be prematurely relegated to the museum, this appeal for the return of superimposed ornamentation must be refused. And remember that architecture was at its lowest ebb in the whole of recorded history, during that part of the last century when the art historian was supreme.

INDEX

- Acanthus 43-6
 Addy, S. O. 187-8
 Advertising 186, 191-202
 Albert, Prince Consort 96-7
 Alison, Archibald 68-71
 Alloys, Light 177-8, 181
 Aluminium 177-8
 Amphibious vehicles 106
 "Applied Art" 21, 63, 78-80, 94, 130
 Arch 38; Romans and 46
 Archaism in design 16
 Archimedes 25
 Architects, and design 23, 205
 Architecture, influence of 38 ff.
 Architecture, 19th-century 65 ff.
 Armstrong, Dr. E. F. 167, 181
Art and Industry 135-6
 Arts and Crafts movement 123
 Ashbee, C. R., 125
 Atmospheric railways 106
- Baker, C. H. Collins 131
 Barman, Christian 177
 Barnsley, Sidney 123, 125, 126-7
 Battle of the Styles 66-7, 67-8
 Bauhaus 209
 Beddington, Jack 144
 Bennett, Arnold 195
 Betjeman, John 127
 Bicycles 181
 Birkenhead 91
 Birmingham 97-8
 Bishop, F. P. 194
 Block boards 167
 Blomfield, Sir Reginald 159
 Bragg, Sir William 183
 Brain, E. and Co., Ltd. 147
 Bridges, iron 66-7
 Bridgwater, Derek 168, 183
 British Empire Exhibition 133, 189
 British Institute of Industrial Art 130
 Brogan, D. W. 156
 Buildwas iron bridge 66
 Burton, Decimus 67
 Buses 180
 Butler, Samuel 80-2
 Byng, *see* Torrington
- Callimachus 43
 Cambodian civilisation 19-20
 Canals 53-4
 Cantilever principle 38
 Casson, Stanley 26
 Cast iron, early uses of 66-7; modern 168-70
 Castor ware 24
 Chairs 183-4
 Chesterton, G. K. 158
 Childe, V. Gordon 24
- Clark, Sir Kenneth 58, 143-4
 Clay, Felix 141
 Clocks 154-5
 Coalbrookdale iron bridge 51, 66
 Cobbett, William 63
 Coffin ornaments 86-7
 Colbert 87
 Collapse of civilisations 19
 Commercial art, defined 18; operation 186 ff.
 Competitions 133
 Corbridge, sculpture at 46-7
 Cotton industry 162-4
 Council of Industrial Design 17
 Craftsmen, and design 23, 24, 117 ff.
 Craftsmen, disappearance of 119
- Decorative art, industrial 203 ff.
 de la Valette, John 135, 159
Design and the Cotton Industry 162
 Design and Industries Association 131-2
 Design, normality of, in production 16
 Designer, appearance of independent 23
 Dickinson, G. Lowes 25
 Disguise and design 146
 Display of goods 186 ff.
 Douglas, Norman 124
 Draughtsmen and design 92-3
- Emmett, John T. 82-5, 141
 Engineer, and architect 76, 92
 Engineer, and industrial designer 31-4
 Erbar type faces 198-9
 Euston Station 72-6
 Evans, Oliver 106
 Exhibition, Great, of 1851 95
 Exhibitions, Industrial Art 135; Trade 188-90
- Fairs 188
 Fitness, and beauty 68-71, 124, 131, 158-9
 Fletcher, B. J. 131
 Forth Bridge 77
 Fry, Roger 127-8, 158, 203-4
 Functionalism 68
 Furniture 125-8
- Gill type faces 198-9
 Gimson, Ernest 123, 125-7
 Glass 171-3
 Goldsworthy, E. C. 178, 181
 Gorell report 92, 130
 Gothenberg exhibition 189
 Gothic revival 58 ff.
 Gramophone 152-4
 Greek architecture 39 ff.

INDEX

- Greek attitude to science 41-2
 Greek revival, 18th-19th century 62
 Greeks, and the artisan 25
- Handicraft revival, results of 128
 Harrison, Tom 157
 Heal, Sir Ambrose 127, 131
 Heal and Son 127
 Hero of Alexandria 25
 Hickey, William 54
 Holme, Geoffrey 135
 Humour 157-8
 Huxley, Aldous 159
- Imagination, importance of, in industry 20-1
 Industrial Architecture, defined 18
 Industrial Art, defined 17
 Industrial Art, indifference to 16
 Industrial Design, as basic operation 29
 Industrial Design, defined 17
 Industrial Revolution, effects on design 27, 51 ff.
 International style 138-9
 Inventiveness 25
Itma 157-8
- Jeffrey, Lord 68-71
 Johnson, Samuel 117
 Jones, Inigo 48
- Kelly, Samuel 113
- Laminated board 167
 Lamp-posts 83-5
 Lang, Archbishop [Lord] 78-80
 Langley, Batty 62
 Leeds 91
 Leslie, S. C. 211
 Lethaby, W. R. 124, 170, 175
 Lighting appliances 155-6
 Locomotives, early 108
 Loewy, Raymond 134
- Machine architecture 18
 Manchester School of Design 87-90
 Marketing 193
 MARS Group 177
 Mass production in ancient world 23
 Materials, influence of 166 ff.
 Meynell, Sir Francis 120
 Middle Ages, in England 118, 121
 Modern movement 159-62
 Morris and Co. 122
 Morris, William 98, 120-8
 Murdock, William 108
 Murray, Gilbert 42
- Nash, John 67
 National Council of Industrial Design 134
- National Register of Industrial Art Designers 134, 206-7
 N.R.D. 207
- Omega Workshops 127-8
 Orders, architectural, Greek 40 ff.
 Roman 46
 Ornament, 19th-century 129
- Packaging 18
 Palladio 48-9
 Paulsson, Gregor 124
 Paxton, Sir Joseph 67
 Petrie, Sir William Flinders 77, 142
 Pevsner, Dr. Nikolaus 138, 207-10
 Phaestos disk 26
 Phillipps, Lisle March 39
 Pick, Frank 131, 132, 143, 210
 Pilkington Brothers Ltd. 172-3
 Plastics 181-4
 Plywood 167
 Post-and-lintel construction 38
 Pottery, in antiquity 23-4
 Printing 196 ff.
 Printing, first invention of 26
 Printing industry, design in 120
 Propaganda, sales 186 ff.
 Prototypes, dependence on 24-5
 Public and the artist 144-5
 Pugin, A. W. 58-9
 Pullman, George Mortimer 112
 Pullman cars 112
- Radio sets 152-4
 Railway architecture 67-8, 71 ff.
 Railway development 106 ff.
 R.D.I. 206
 Read, Dr. Herbert 135-9, 147
 Red House, the 121-2
 Refrigerator van 178
 Renaissance and architecture 47-9
 Retail buyer and design 147-50
 "Rocket," The 108
 Roll, Erich 53
 Romans, and architecture 46-7
 Romantic Movement 58 ff.
 Rose, Walter 119, 167
 Rothenstein, Michael 144
 Royal Society of Arts 94, 96-7, 133, 206
 Rural crafts 119-20
 Ruskin, John 58, 68, 82
 Russell, Gilbert 194, 195
 Russell, Gordon 125, 127
- Sarai 24
 Scotland 117
 Selling, *see* Marketing
 Shand, P. Morton 167
 Sheraton 126
 Shops, medieval 187-8

INDUSTRIAL ART EXPLAINED

- Sidney, Samuel 71-6, 82, 86 ff., 94,
 97-8, 109-12, 162
 Sight, and architecture 39
 Sitwell, Sir Osbert 20
 Slavery, effects of 19, 24, 27
 Smith, Sir Hubert Llewellyn 130
 Soho factory 53
 Songs, trade 192
 Spraying of metals 169
 Stabler, Harold 131
 Stands, exhibition 190-1
 Steam, development of, 106 ff.
 Steamboats, American 112-13
 Steam carriages 108
 Stephenson, George 106, 108
 Stroud Valley mills 53, 91
 Sweden 124-5
 Symbols, trade 187
 Symington, William 108
- Tchcou Ta-Kouan 19
 Telford, Thomas 66
 Thomas, M. Hartland 173-7
 Thomas, Sir Miles 145-6
 Thompson, Denys 194
 Torrington, Viscount 51, 109
 Tower Bridge 77
 Training of designers 205 ff.
 Twain, Mark 113
- Type faces 196 ff.
 Underground, London 132
 United States 210
 Vehicle design 178-80
 Vitruvius 43, 47
 Waddington, Dr. C. H. 157
 Wales 117
 Walpole, Horace 50, 58
 Walton, George 125
 Water wheel 24
 Weaver, Sir Lawrence 132
 Wedgwood, J. 94
 Weekley, Montague 121
 Wells, H. G. 41-2, 77, 205
 Whewell, Dr. William 95, 100-1
 Wilenski, R. H. 87
 Williams, Frederick S. 76
 Windsor, Duke of [Edward VIII] 134
 Wood 166-8
 Woodworking 118-19
 Wotton, Sir Henry 49
 Wren, Sir Christopher 50
 Wyatt, James 58
 Wyatt, Sir Matthew Digby 93
 Young, G. M. 101

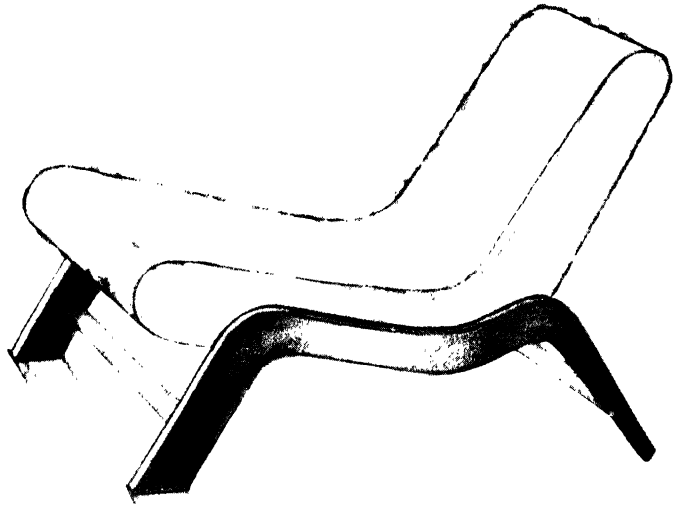
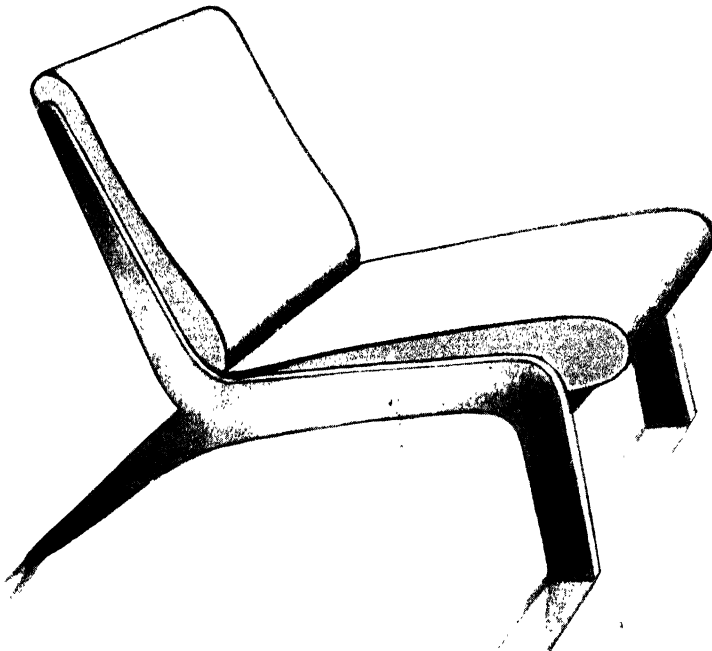


PLATE 1.—Two chairs in plywood and rubber, designed by Michael Rachlis for the Metropolitan Plywood Company. The plywood frames are veneered and polished or cellulosed; the upholstery is of sponge rubber or "Resilitex," or hair in rubber.
(See pages 182 and 184.)



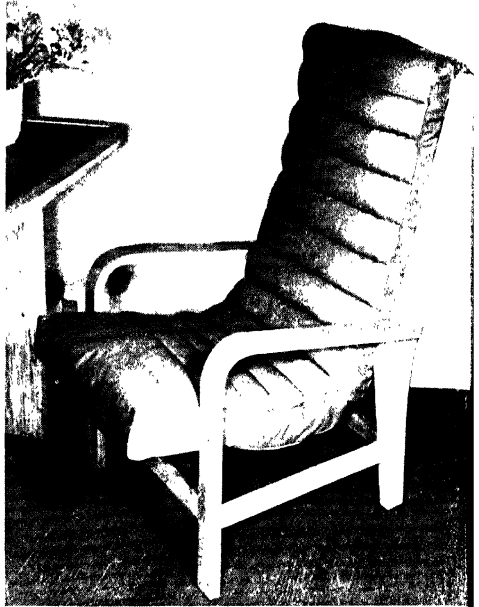


PLATE 2.—Chair designed by Milner Gray, R.D.I., for Messrs. Christie-Tyler. *Below*, is a sun-lounge divan with an adjustable head-rest, designed by Wells Coates, F.R.I.B.A., R.D.I., for Pel Limited.





PLATE 3.—A typewriting desk and chair, designed by Wells Coates, F.R.I.B.A., R.D.I. The desk folds away into standard wall cupboards when not in use. A socket placed centrally on the desk top takes a table lamp. The chair is the standard type designed by Wells Coates for Pel Limited.

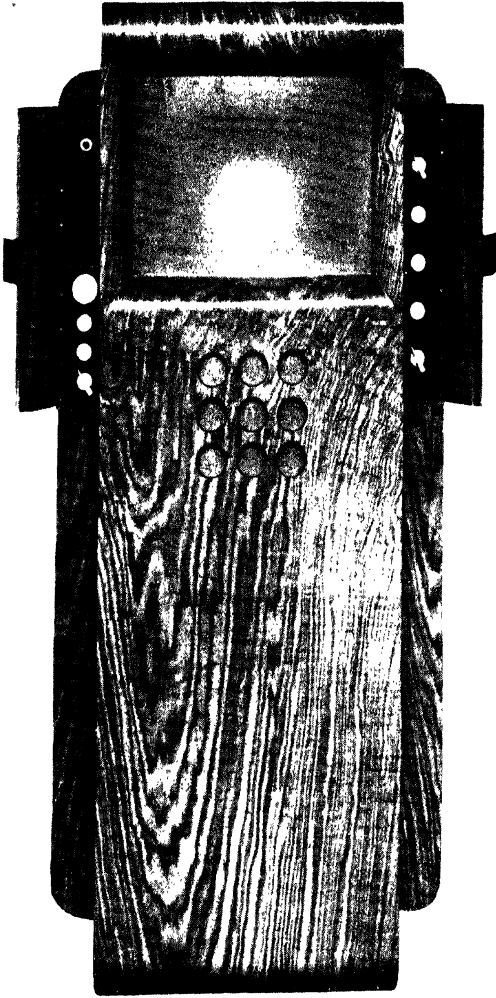


PLATE 4.—A television set designed by Misha Black, M.Inst.R.A., M.S.I.A., for E. K. Cole Limited. The controls are concealed by secret doors to avoid distraction from the television screen. The cabinet is veneered in teak, but halving and quartering have been dispensed with, the set relying on its general form and proportion and the natural pattern of the veneer for the decorative effect.

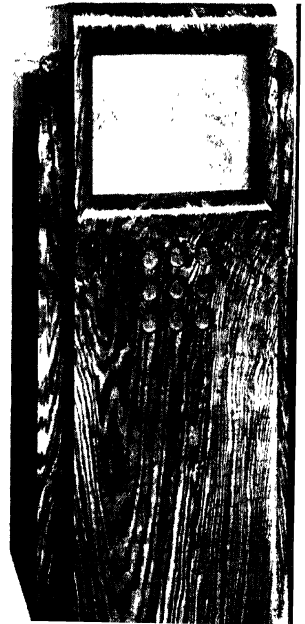
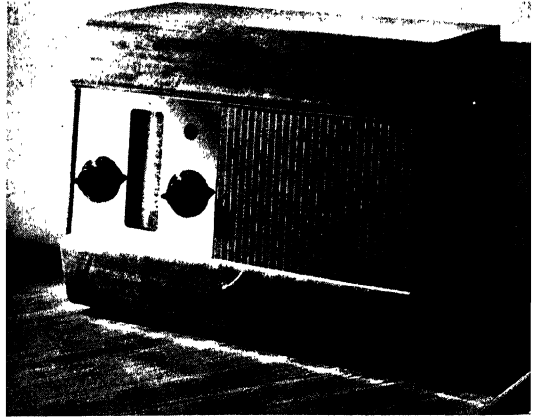
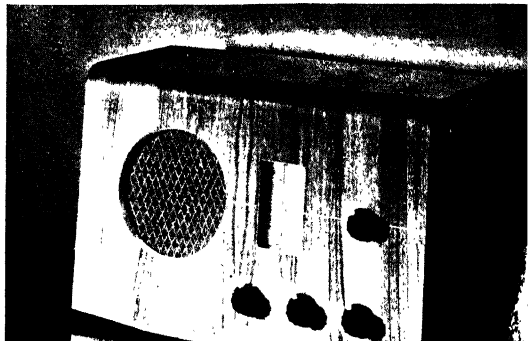


PLATE 5.—Two radio table sets designed by R. D. Russell, R.D.I., for Murphy Radio Limited. *Above right:* Set A.50 was one of the most expensive in the Murphy range for 1938. Honduras mahogany is used on the top and front: the ends of the cabinet are of straight-grained Honduras mahogany veneered on



plywood, and the whole is finished with a deep eggshell polish, the wood being left in its natural colour. Besides openings for speaker and scale, four controls and a tuning indicator had to be incorporated in the front. The apparent number of controls is reduced by combining them into two concentric pairs on either side of the scale. A control panel was devised in glass with dark gunmetal coloured mirror plating on the back polished clear over scale and tuning indicator and drilled for the controls. The speaker fabric, purposely woven in the same dark gunmetal colour with a thin white stripe, is mounted on a frame which butts up to the control panel and continues right across to the other end of the cabinet. A narrow strip of white rubber cushions the control and speaker panels top and bottom. *Below right:* Set B.31 was the lowest in price in the Murphy range for 1937. The top and front are formed by bending one piece of plywood and, being the parts most in evidence, are veneered with well marked straight-grained walnut, left in its natural colour, while the ends are of unveneered birch ply stained to a dark warm brown. By taking the plywood front right down to the table and splaying it up at each end, finger-grips for lifting are provided, the expense of a visible and finished plinth is saved, and the result is more pleasant in appearance and less vulnerable in use than uncompromising square corners would have been. The edges of the openings cut in the front are carefully smoothed and filled so that the plywood laminations will not show, and are then finished in ivory enamel. The speaker fabric is pale venetian red. The positions of controls in relation to the scale and of the scale in relation to the speaker, the arrangement of the whole group within the framework of the cabinet and the proportions of the complete "works" are all subject to mechanical and electrical limitations and, to give a satisfactory result, must be influenced by the designer of the cabinet in close co-operation with the mechanical and electrical designers from the beginning.

(Reproduced by courtesy of Murphy Radio Limited.)



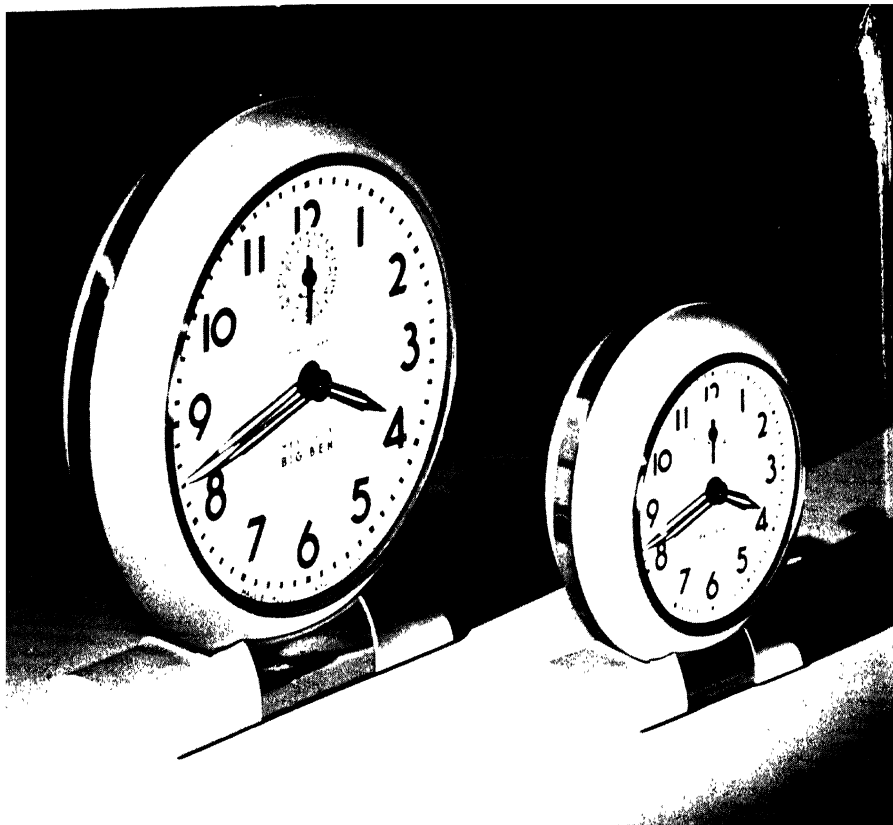
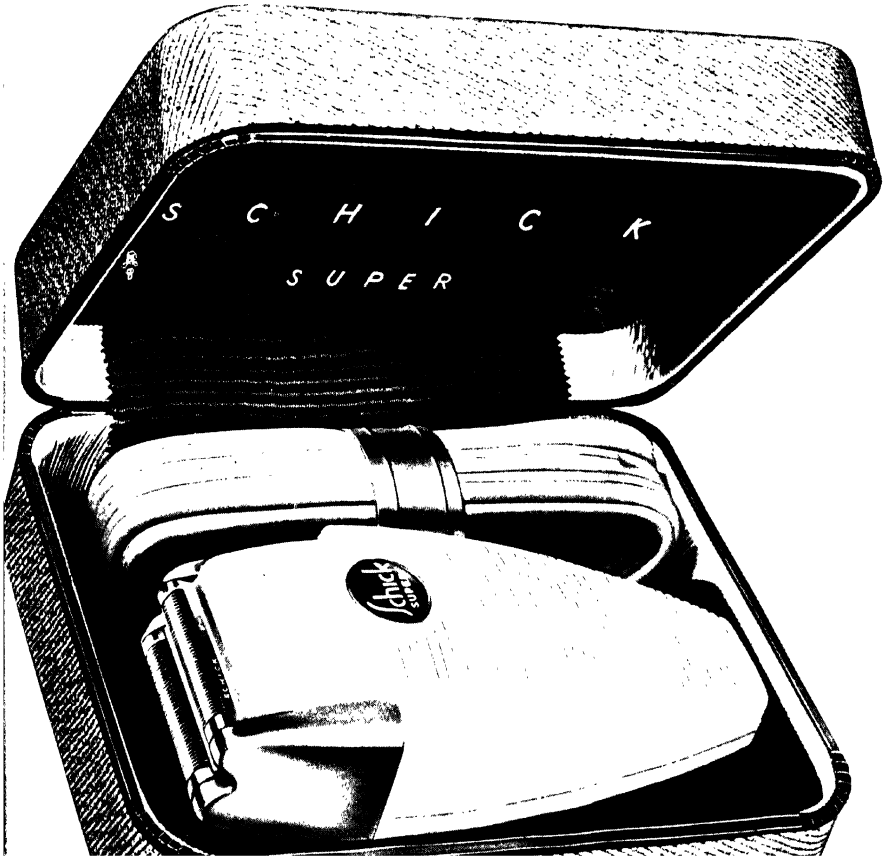
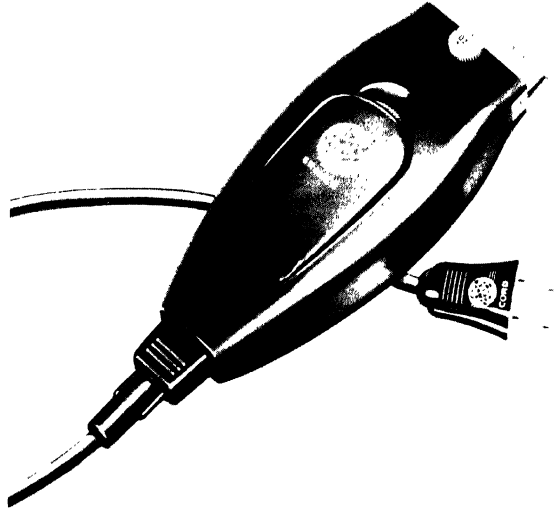


PLATE 6.—Two clocks, designed by Henry Dreyfuss of New York, for the Westclox Division of General Time Instruments Corporation, U.S.A. Known as the “Big Ben” and “Baby Ben” models, the clock cases are made of brass, with lacquer finishes. The colour is ivory, with gold trim. Height of the “Big Ben” model: $5\frac{1}{2}$ ”; height of “Baby Ben,” $3\frac{1}{2}$ ”.

PLATE 7.—The Schick electric shaver. *To the right*, is the model as it was before re-design by Raymond Loewy. *Below*, is the 1942 “double header” model designed by Raymond Loewy.



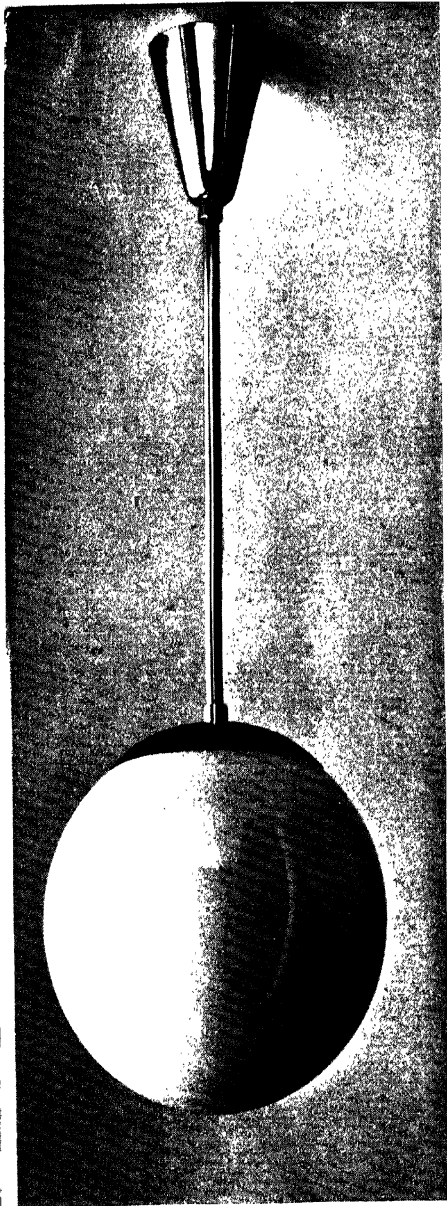


PLATE 8.—“Ultralux” electric light fittings,
designed by A. B. Read, A.R.C.A.,
R.D.I., for Troughton and Young Limited.

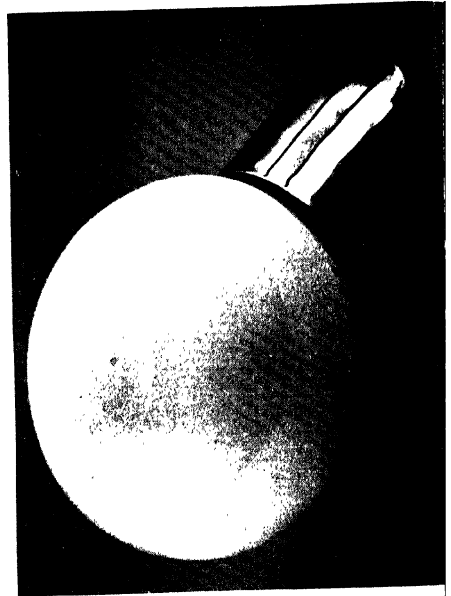




PLATE 9.—Decanter and glasses, designed by Keith Murray, F.R.I.B.A., R.D.I., and made by Stevens and Williams Limited.

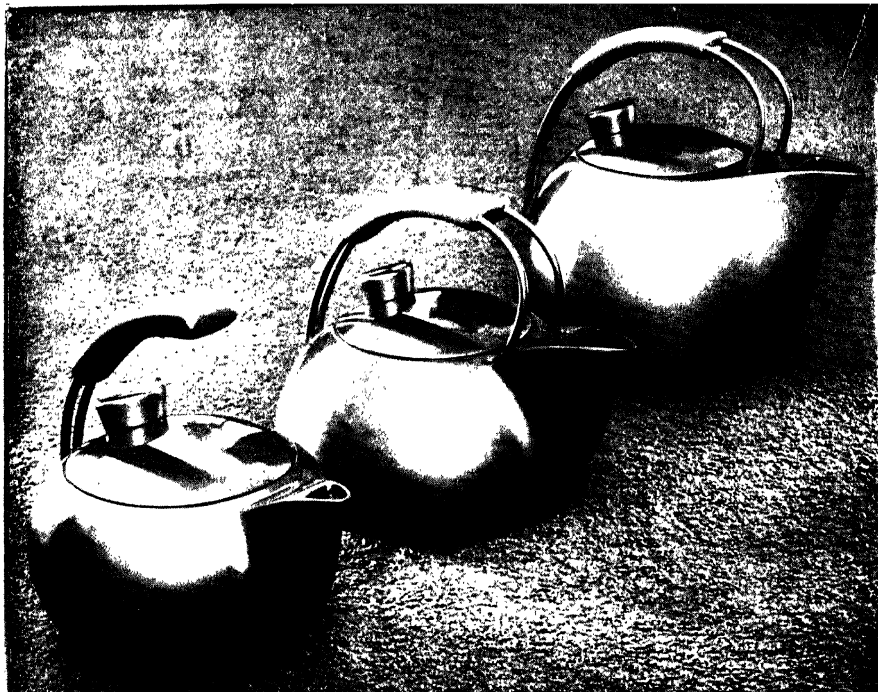


PLATE 10.—A five-quart cast aluminum kettle (*top right*), a three-quart spun aluminum kettle (*centre*), and an 8-cup spun aluminum teapot (*left*), designed to harmonise with the kettles. Both kettles and teapot have a plastic grip.

Right: An 8-cup coffee percolator, of aluminum.

*By the Design Research
Department of Alu-
minium Laboratories*



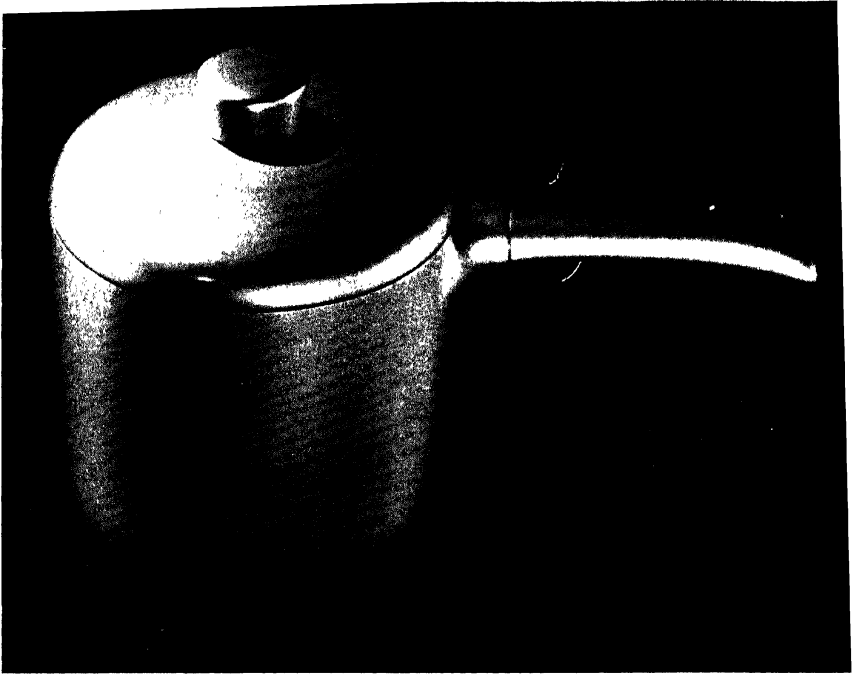
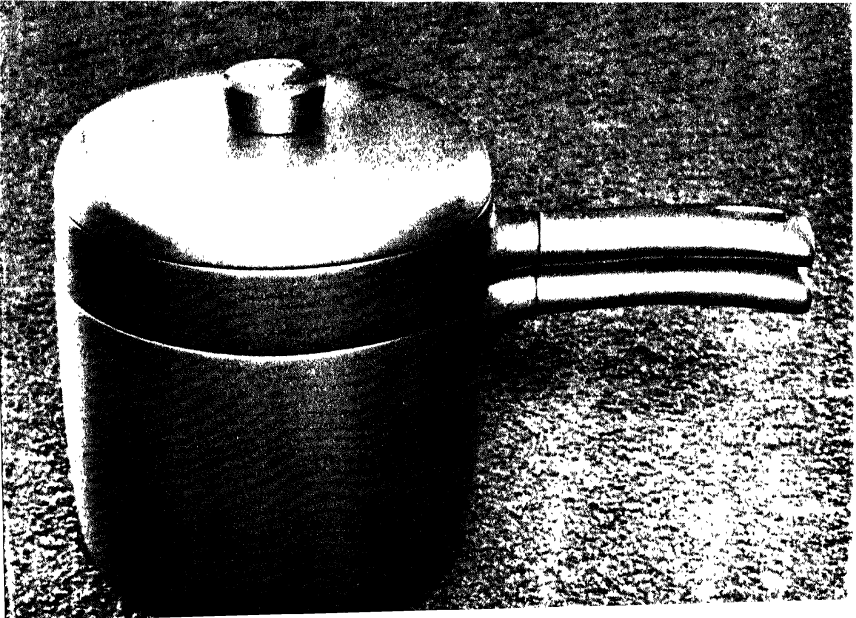


PLATE 11.—Five-pint saucepan in aluminium. *Below*, drawn double saucepan in aluminium. The lower utensil is the standard five-pint saucepan.

By the Design Research Department of Aluminium Laboratories Limited, Montreal.



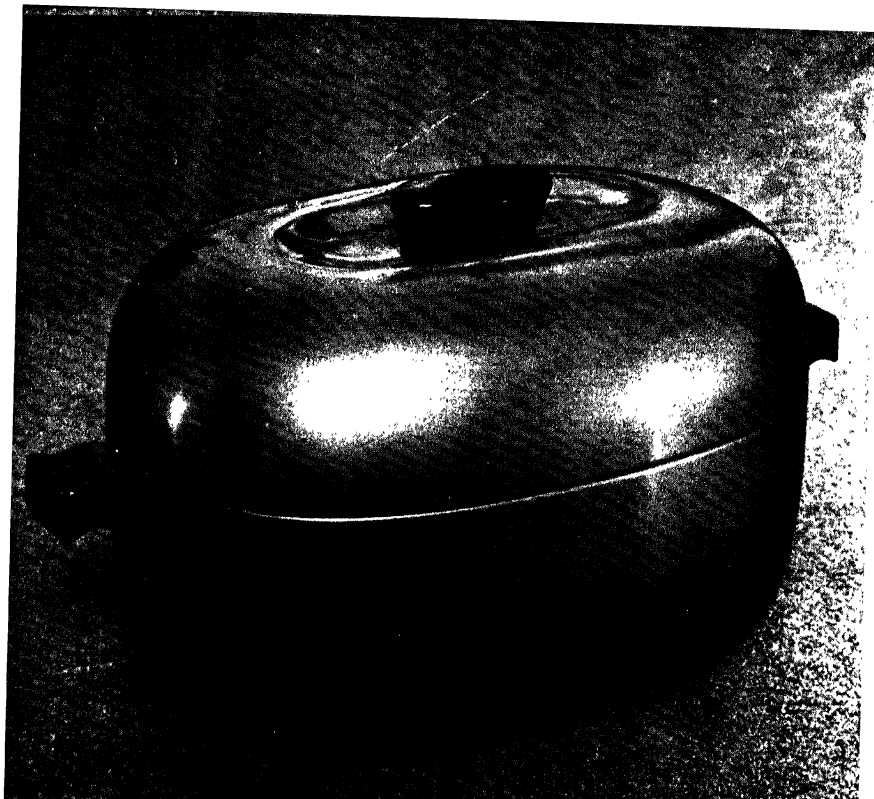


PLATE 12.—A roaster of aluminium, with insulated plastic grips. The dimensions are 11" \times 16" \times 8½" high. It will hold a 12-lb. turkey, and has a self-basting cover.

By the Design Research Department of Aluminium Laboratories Limited, Montreal.



PLATE 13.—Cooking vessels of vitreous enamelled cast iron. The metal, to which a coating of vitreous enamel is fused, has to be of special enamelling quality. The vitreous enamel itself has a coloured, glass-like body which is fused to the iron at dull red heat. It provides a hard, durable surface, difficult to scratch or chip. The shapes are simple, and the utensils are available in three pastel colours, blue, green and light brown.

(Reproduced by courtesy of Radiation Limited.)

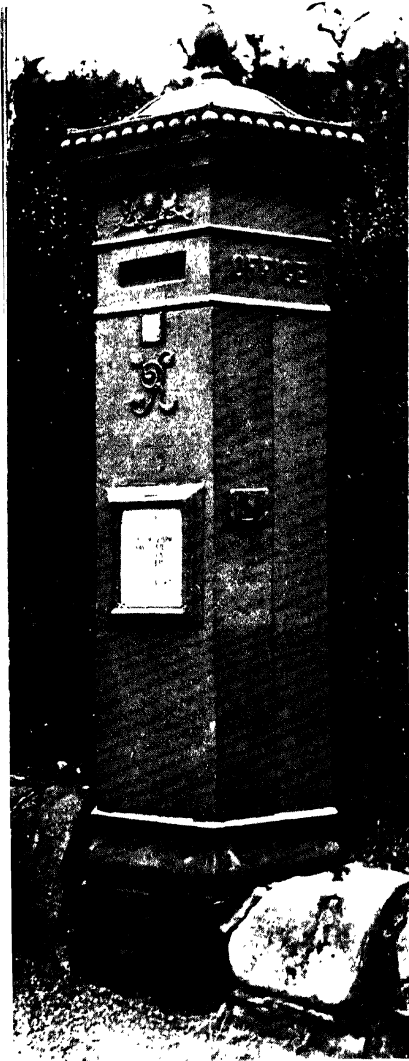
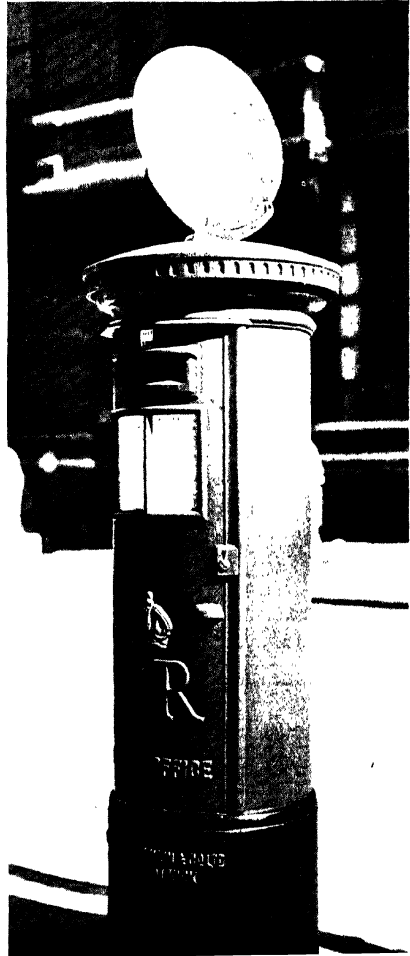


PLATE 14.

Left: the eight-sided cast iron pillar box of the late Victorian period. The top is boldly ornamental, and preserves affinities with classic architecture.

Below: the Air Mail pillar box of to-day, representing a straightforward, uncomplicated use of cast iron.



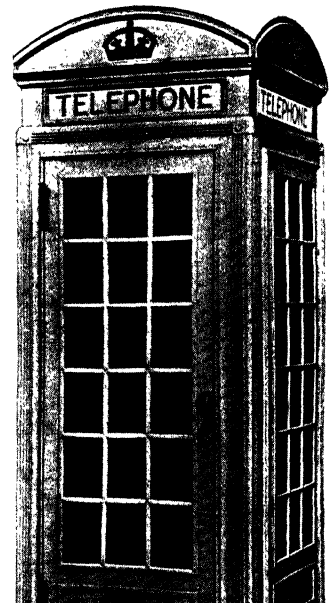
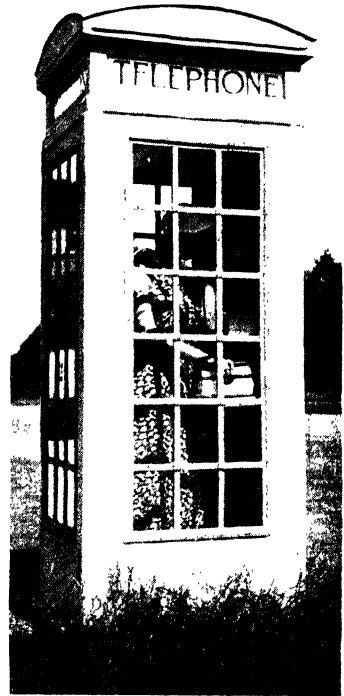
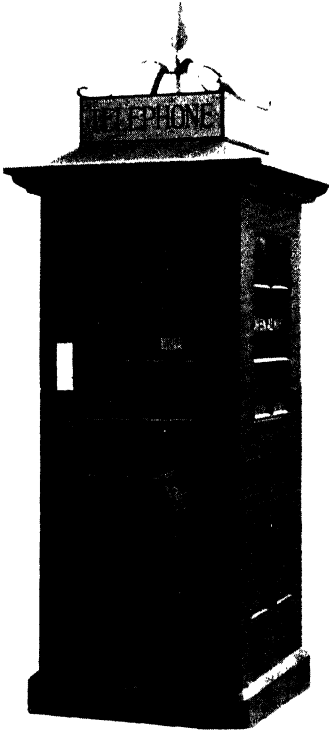
*These illustrations are reproduced by courtesy
of the Postmaster General.*

PLATE 15.
G.P.O. TELEPHONE KIOSKS
PROGRESS IN DESIGN

Below, is an early type in wood, with a rather unhappy roof: just a close-fitting little wooden hut.

To the right, is the next stage, metal and concrete, with good ventilation and more room, even for quite large people.

Below right, the kiosk designed by Sir Giles Gilbert Scott, P.P.R.I.B.A., and made in cast-iron. Efficient, well ventilated, and capable of resisting a great deal of hard wear.



*These illustrations are reproduced by courtesy of the
Postmaster General.*

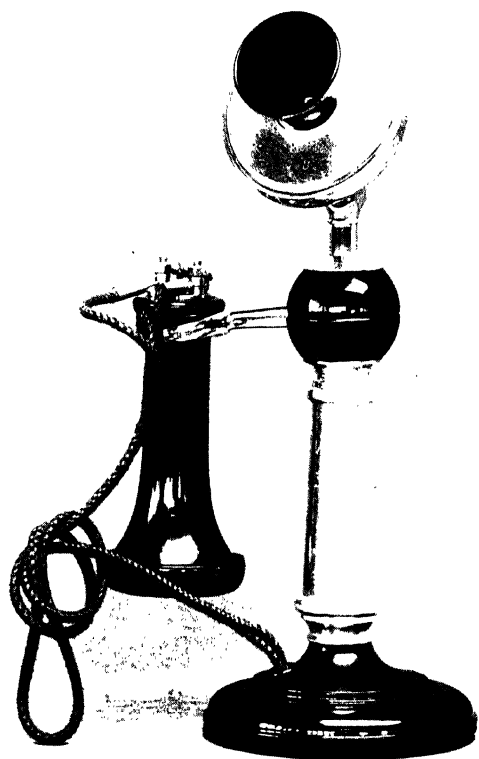
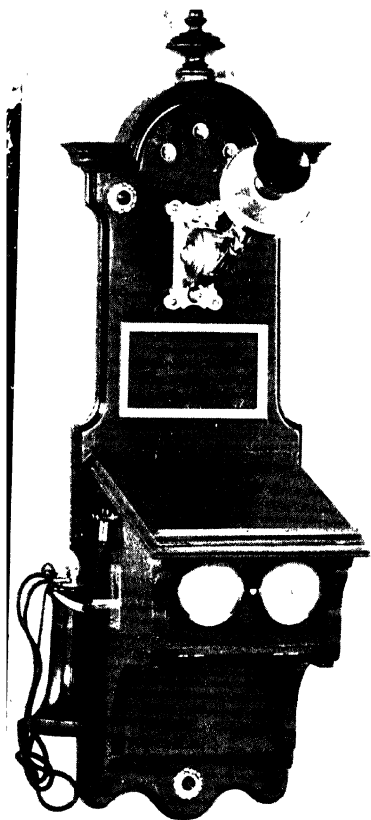


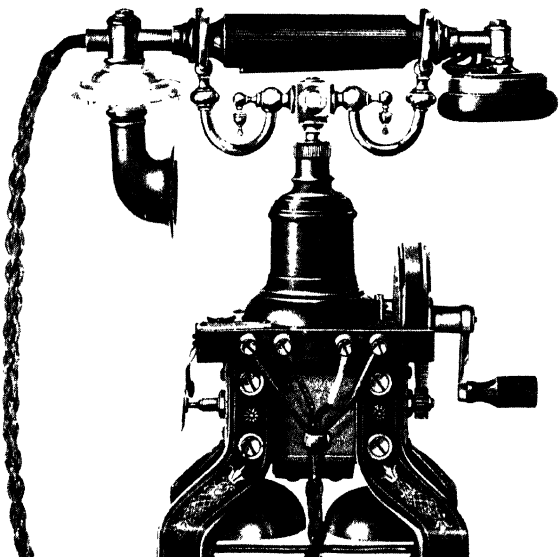
PLATE 16.

G.P.O. TELEPHONES
PROGRESS IN DESIGN

Above: Wall instrument
in use 1900.

Above right: Pedestal tele-
phone in use 1900. (This
type was in general use
for over thirty years.)

To the right: The magneto
telephone, 1910: the real
forerunner of the modern
telephone.



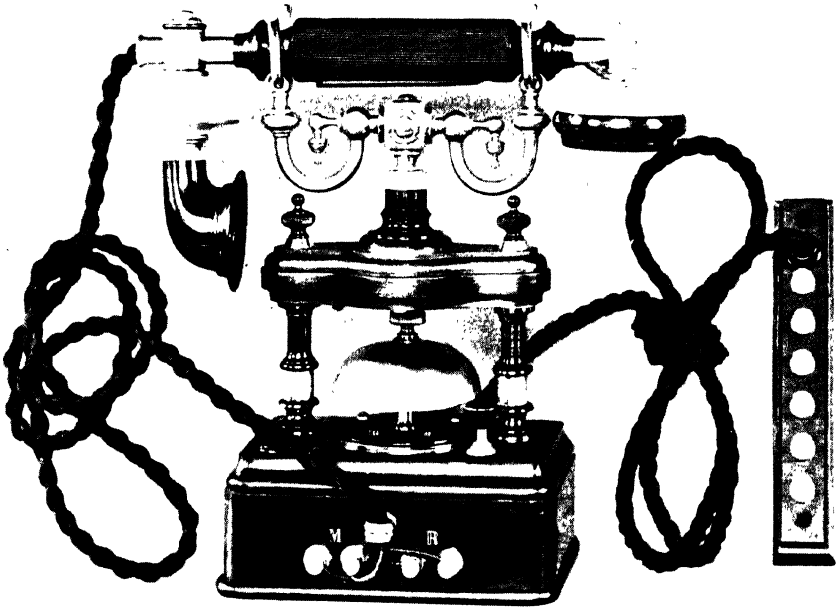


PLATE 17.

Above: Local battery hand-combination telephone.

Below: Hand microtelephone with dialling code list, 1938.

These illustrations are reproduced by courtesy of the Postmaster General.



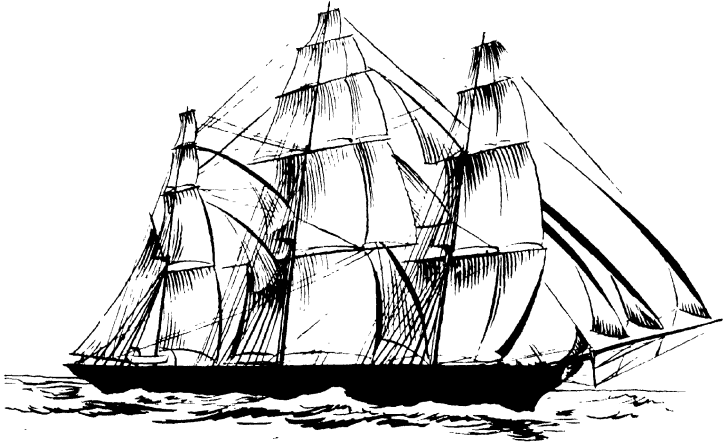
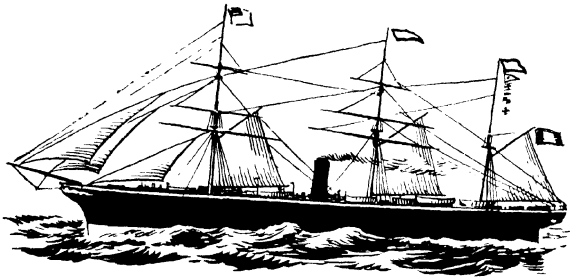


PLATE 18.—A China Clipper: one of the final stages in the evolution of the sailing ship. The transitional stage between sail and steam was the nineteenth-century liner which combined both forms of power.



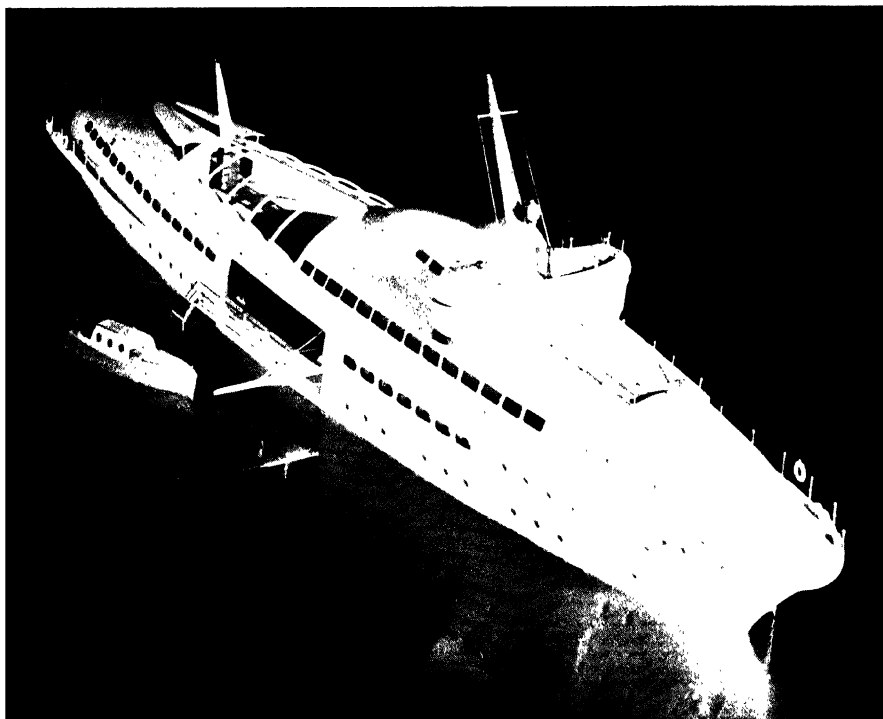
[These illustrations are from "The Story of the Ship," by Geoffrey Bounphrey, and are reproduced by courtesy of A. & C. Black Limited.]

The funnel became the dominating feature of the steamship, symbolic of its power. Masts were merely vestigial.





PLATE 19.—During the nineteen 'twenties and 'thirties the form of the steamship was changing. Above is the German liner *Bremen*. (Reproduced from "*The Story of the Ship*," by Geoffrey Bounphrey, by courtesy of A. & C. Black Limited.) The next stage in the development of ship design, and some glimpse of the future, is indicated below by the Diesel yacht designed by Norman Bel Geddes for Axel Wenner-Gren.



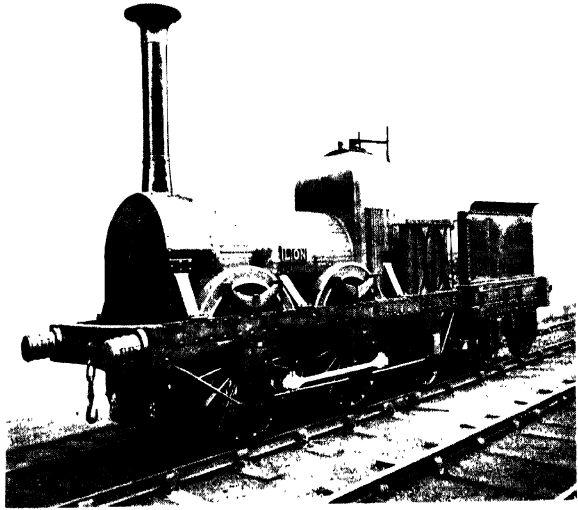
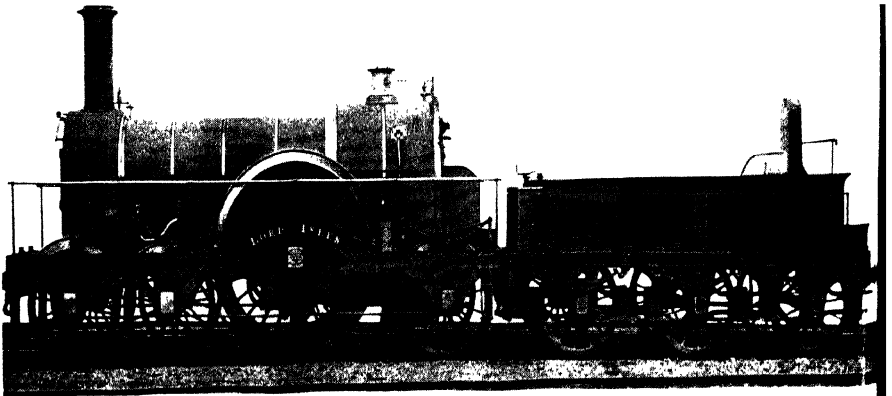


PLATE 20.—This locomotive, “The Lion,” was the next stage after Stephenson’s “Rocket.” (See pages 107 and 110.) Already later forms were being foreshadowed: the tall funnel was still retained: the outer covering of the boiler was wood, but the lines of the locomotive were being “tidied up.” (Reproduced by courtesy of the London Midland and Scottish Railway Company.) Below, another progressive stage is shown by the old broad-gauge Great Western Railway locomotive, “Lord of the Isles.” (Reproduced by courtesy of the Great Western Railway Company.) An intermediate stage is illustrated on page 113.



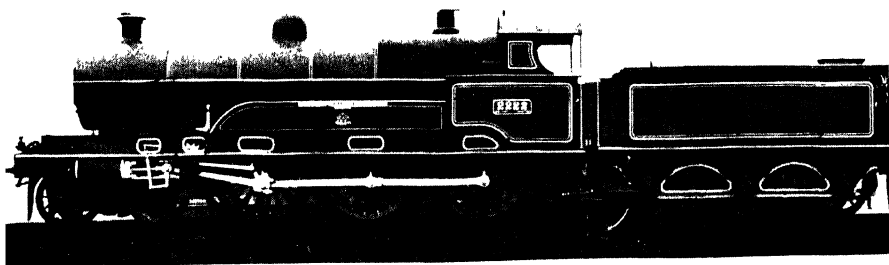
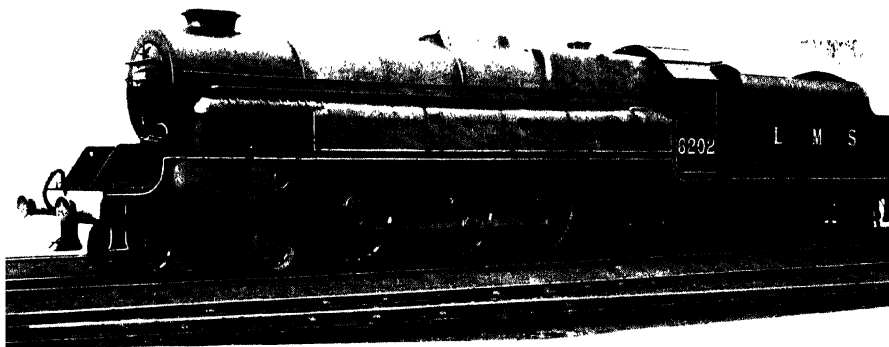


PLATE 21.—A locomotive of the London North Western Railway, showing a pre-1914 stage of development.



A contemporary locomotive: turbine engine No. 6202 of the London Midland and Scottish Railway. (These illustrations are reproduced by courtesy of the London Midland and Scottish Railway Company.) Below is the latest type of Great Western passenger train locomotive, "King George V."

(Reproduced by courtesy of the Great Western Railway Company.)



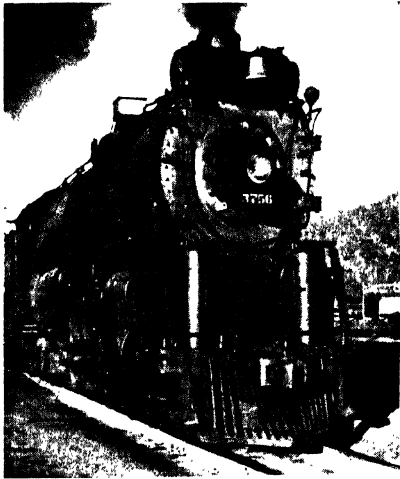
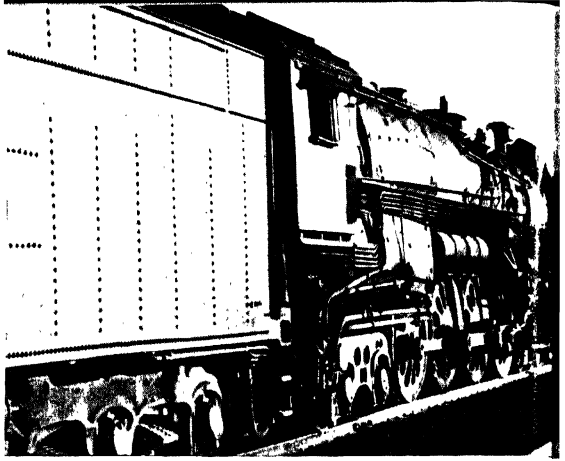


PLATE 22.—Typical locomotives and rolling stock in service on United States railroads. A great deal of “tidying up” is called for with such locomotives: the passenger cars still retain the original Pullman form. The progress of “train tidying” is shown on the next four plates.

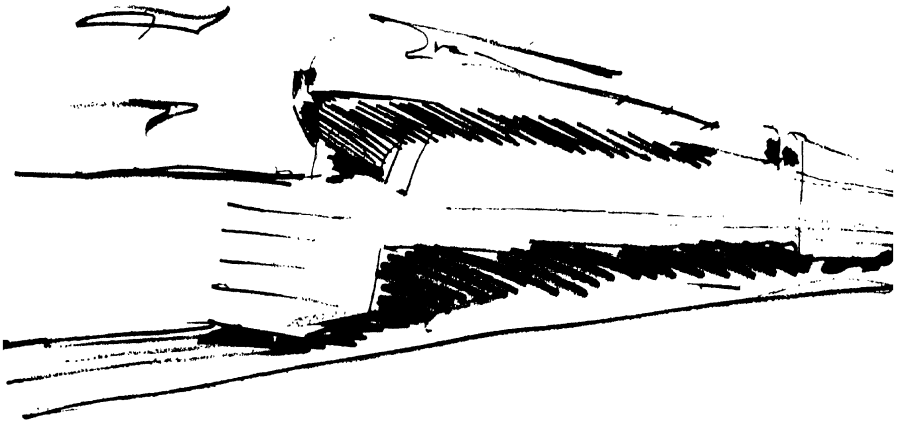


PROGRESS OF A PROJECT: Stage 1

S1 TYPE STEAM LOCOMOTIVE, PENNSYLVANIA RAILROAD, U.S.A.
 DESIGNED BY RAYMOND LOEWY IN COLLABORATION WITH
 PENNSYLVANIA RAILROAD ENGINEERS

Raymond Loewy is design consultant to the Pennsylvania Railroad, and his work includes: locomotives, trains, stations, ticket offices, special displays, station shops, restaurants, bars, and so forth. (See Appendix I, page 226.) S1 is a typical project for the Railroad, and this is a brief, illustrated account of the beginning and progress of this piece of industrial design.

Before the work can start, the builder (Baldwin Locomotive Works) and the mechanical engineering staff of the Pennsylvania Railroad have designed the mechanism. When this practical work is done, the design consultant is summoned. First, a study is made in the designers' office of the detailed blueprints. Then dozens of quick-impression sketches are made, such as this:—



Such sketches determine the general character the locomotive will assume.

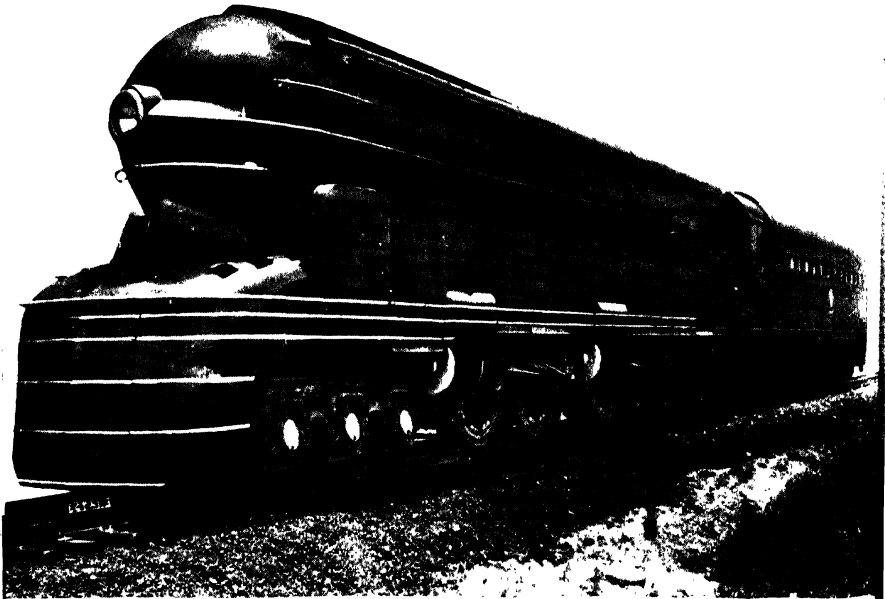
TIME—ONE WEEK.

PROGRESS OF A PROJECT: Stage 5

When the client and the builder approve, the design is ready for production. All drawings and the model are then turned over to the builder for constant reference during construction. A large portion of the work on the S1 was done in the Altoona shop of the Pennsylvania Railroad. Wherever a question of styling was considered, one of the designer's men was present in the shops to supervise.

Decorative striping and lettering were applied after the locomotive was finished. These were tested in three-dimensions on the model, while the building was progressing.

There is no normal pattern for such jobs. In the case of the S1 the actual building was started before the complete design was approved, since many of the mechanical features (frame, driving gear, boiler, etc.) had been settled upon before the consultant came into the picture. Often, however, the designer starts his work at the same time as the engineering staffs. In the course of this simultaneous work, the designer often makes recommendations which are adopted by the engineers.



The Completed Locomotive

TOTAL TIME—from blueprint to rails—1½ years.

This locomotive was the largest of its type when built. It was designed out to maximum clearances. As a consequence, little superfluous hardware or features could be added to the "skin"; the main problem was to use the existing surfaces, to determine the proportions of skirts and sheet metal sections; and to add such features as the bullet nose, headlight with fins, and deflector.

Raymond Loewy was particularly concerned with the design of the boiler nose (smoke box); headlight, side marker; smoke deflector; all skirting (side); cow catcher;



'Bus Driver (to charioteer of broken-down motor-car). "I've been tellin' yer al' the week to taikie it 'ome, an' now yer wants to, yer cawn't!"

(Reproduced by permission of the proprietors of "Punch.")

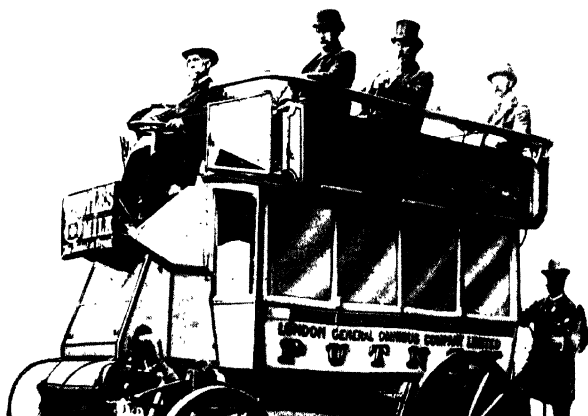
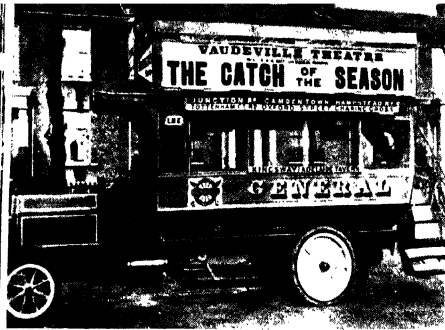


PLATE 27.—The jibe at the new form of traffic appeared in *Punch* in January 1902; but even then 'buses' without horses were being driven in the streets of London. The progress of bus design through forty-five years is shown on the next plate. (To the left is the early type of L.G.O.C. motor-bus with horse 'bus body.)



1910. The A-type Milner Daimler "General"



The NS-type: late nineteen 'twenties



1914. The B-type "General"



STL-type: late 'thirties



1920. The K-type: below, the S-type, 1923



RT-type. Latest in service (1945)

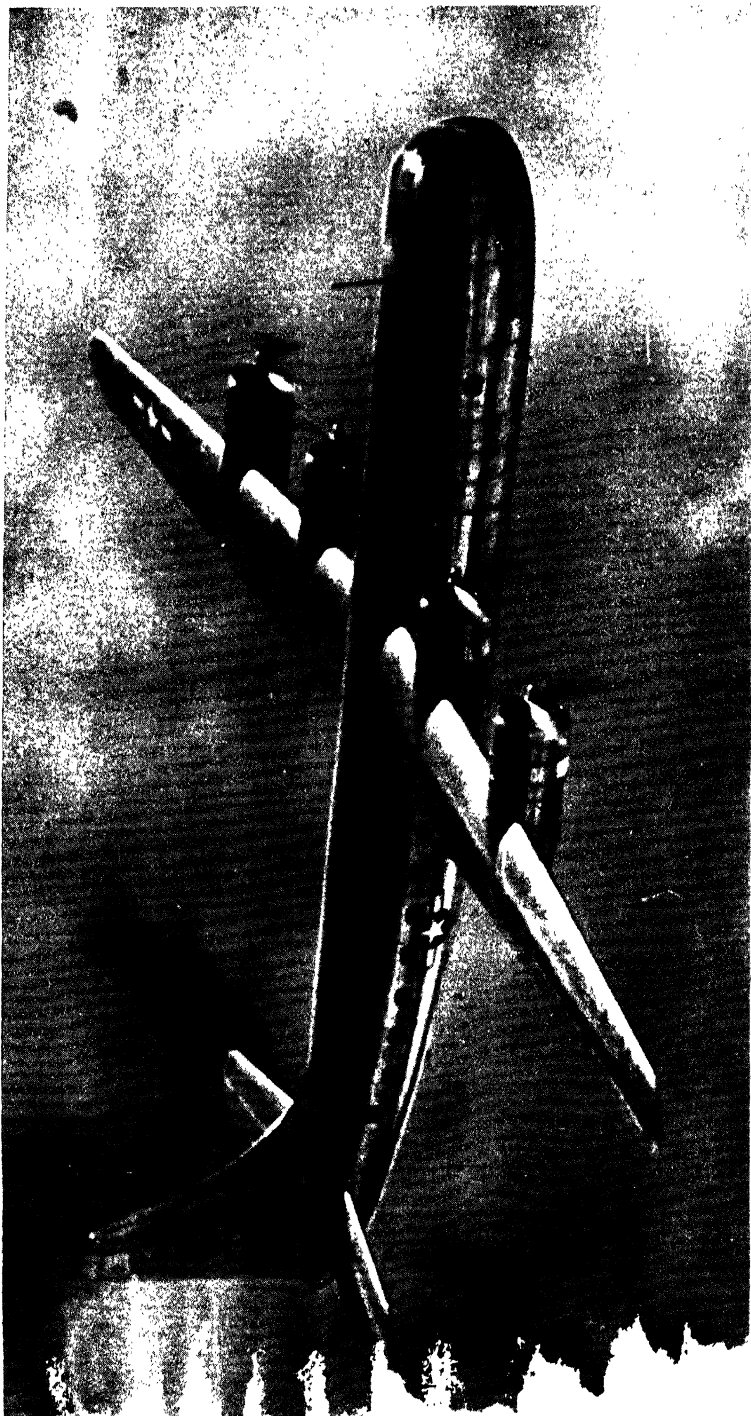
PLATE 28.—Evolution of the Motor 'Bus

From the early type with the horse 'bus body, shown on Plate 27, the lines of the 'bus have been improved, the accommodation and comfort have been increased, and the welfare of drivers and conductors has been studied as well as that of the passenger. A record of steady and continuous progress. These illustrations are reprinted



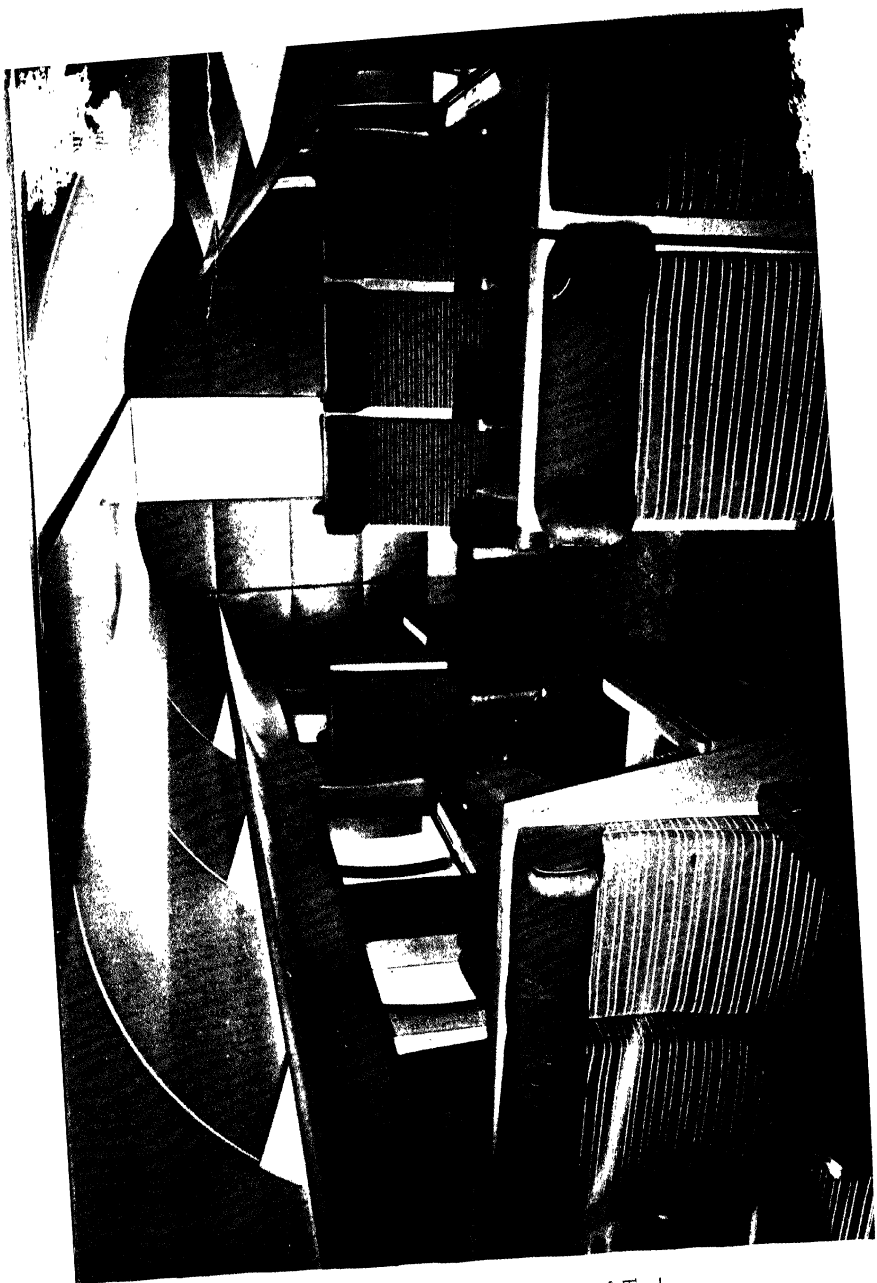


PLATE 29.—The aeroplane started clean. Unhampered by any prototype, its form evolved without traditional limitations or sentimental recollections to hamper its development. Here is the Viking airliner, a British machine produced by Vickers-Armstrong.



The new Liberator air liner shown in flight. It is designed to carry 48 passengers in the daytime; a sleeper plane will carry 24. The gross weight is 56,000 lbs.; it is 90 feet long from nose to tail, and has a wing spread of 110 ft. It is built for the Consolidated Vultee Aircraft Corporation.

The interior of the liner, which is model 39, is shown below.



Con-
Vultec
liner.
terior of
car, show-
agement
seats. The
on the floor
special weave,
only two
he square
The interior
ent of the air-
designed
rvy Dreyfuss,
Consolidated
craft, Cor-
station.

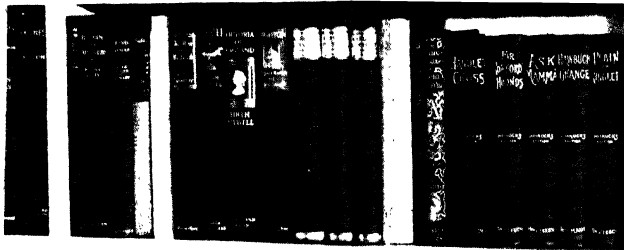


PLATE 32. — Early nineteenth-century machine design in wood. This wool winder, shown closed and open, is typical of the early and ingenious combinations of wood, metal and other materials, which were associated for the purpose of performing some mechanical function. The framework of this device consists of mahogany members, pierced and tied together at the ends with ribbon, and sliding up and down a metal rod. The base, and the rim of the basket, are of satinwood. This design, like some of the early steam engines, is a compromise, typical of an age that was passing from an almost universal use of wood to an almost universal use of metal.

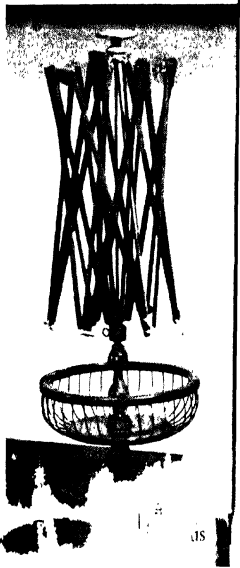
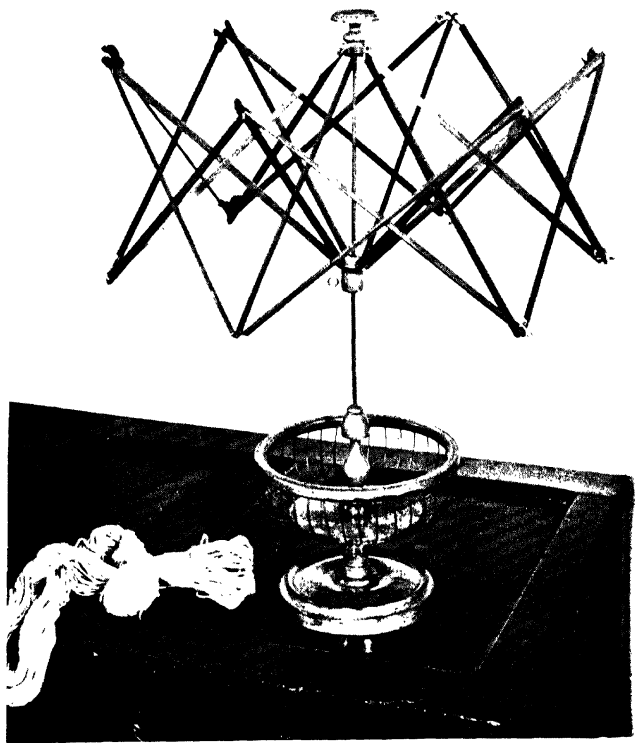
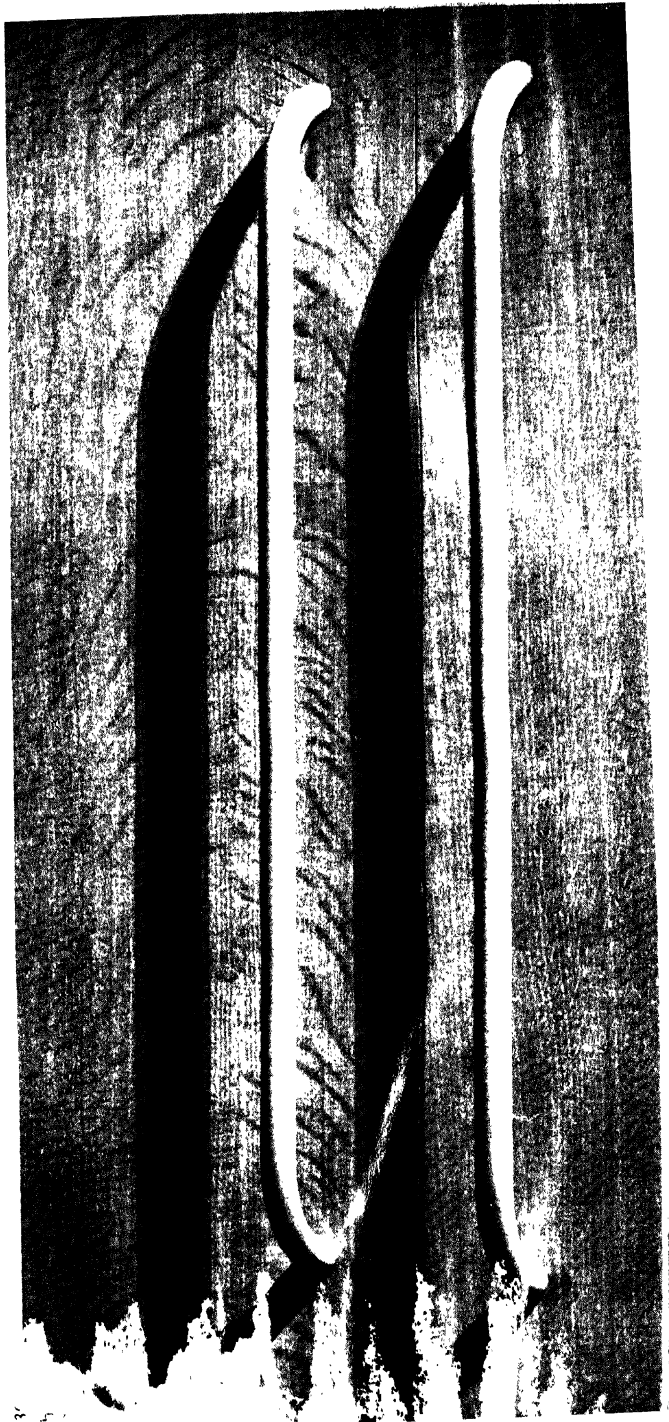


PLATE 33. — Modern combinations of materials are ingenious without being untidy. These bow handles, designed by Wells Coates, are the first of a series of handles finished in tinted plastic sheath drawn over steel tube, with patent "secret" fixing method. They are manufactured by Taylor Pearse and Company, under the name of "Tayloroid" handles, in a range of standard sizes.



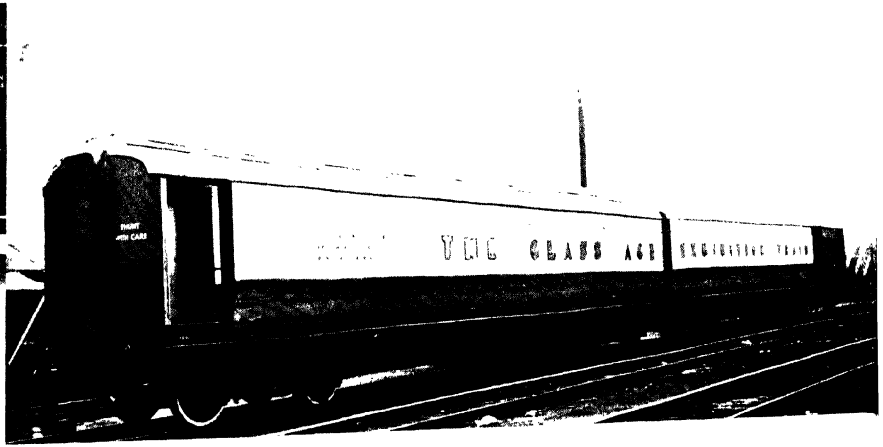


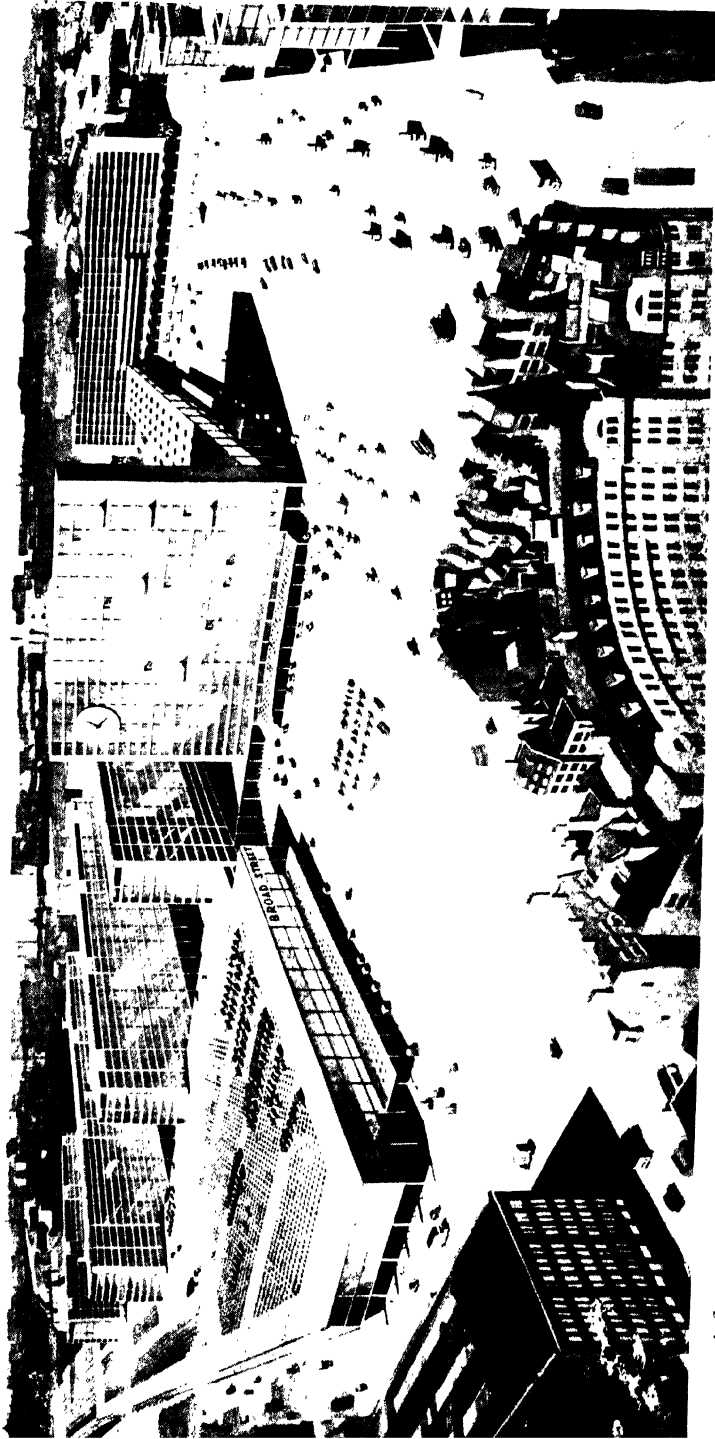
PLATE 34.—A travelling exhibition train, to demonstrate the industrial and decorative uses of glass, was designed in 1937 by Kenneth Cheesman for Pilkington Brothers Limited. It consisted of two converted saloon railway coaches. Externally the coaches were partially covered with blue mirror "Vitroflex" with the lettering of steel blue polished plate toughened glass. (See page 173.)





PLATE 35.—Above and opposite are two views of the interior of one of the cars of the "Age of the Exhibition Train." It represents a car that was advertising in three different ways.

31. ted



4 The influence of materials on architectural design is shown by this plate and the two that follow. The work of a "Glass Age Town Planning" firm, formed by Pilkington Brothers Limited, is illustrated. (See page 173.) Six architects were invited to redesign certain areas of London, and other results were remarkable. For example, this open space and these uncramped, light and airy buildings could replace the present congested middle of Broad Street and Broad Street stations, in London, if modern methods of construction and modern materials were fully employed. Design by F. R. S. Yorke, F.R.I.B.A. Drawing by Norman Howard.

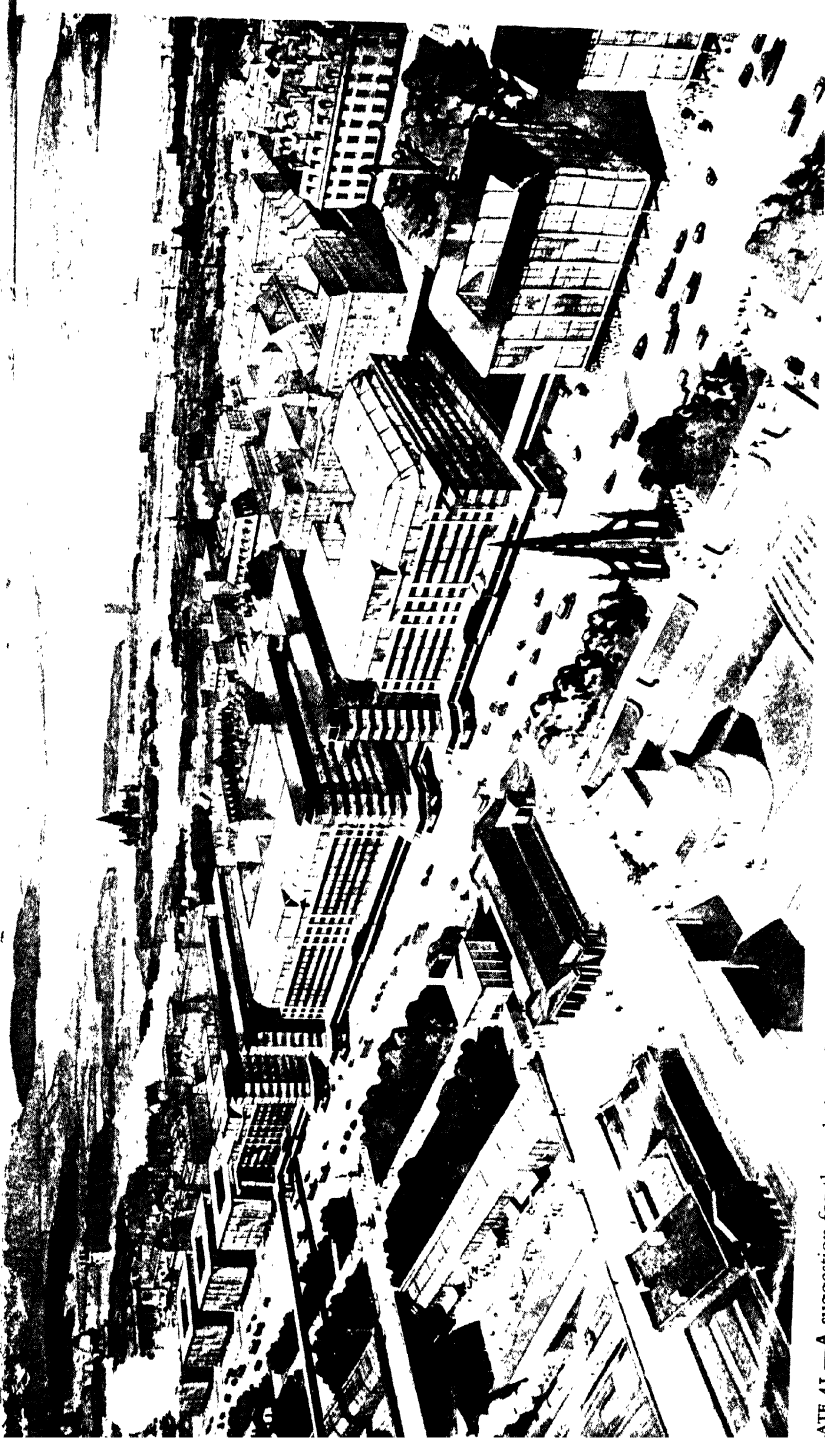


PLATE 41.—A suggestion for the redesign of Princes Street, Edinburgh, taking full advantage of modern methods of glass manufacture and glazing technique. Design by Robert Jordan, F.R.I.B.A. Drawing by Norman Howard. (See Plates 40 and 42, also page 173.)



PLATE 42.—Plates 40 and 41 show two examples of the work of the "Glass Age Town Planning Committee." Above is a solution for the Bond Street area of London, by Howard Robertson, F.R.I.B.A. (Drawing by Norman Howard).

But the new age of architectural design has arrived: buildings such as the Arnos Grove station on the London Underground system, designed by Charles Holden, F.R.I.B.A., show what can be done with modern materials by imaginative designers.

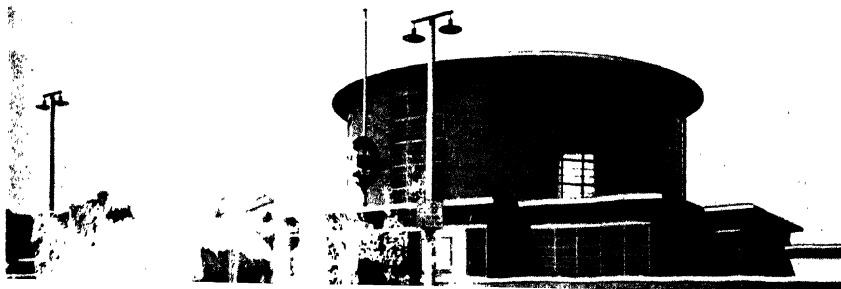




PLATE 43.—*Above:* Bernini's Tuscan colonnades, St. Peter's, Rome.



Peter Jones' shop in Sloane Square, London. *Architects:* Slater and Moberly associated with William Crabtree and Professor Sir Charles Reilly.

The beginning of a new mastery of materials and forms comparable to the mastery exercised by architects who worked with the classic orders.



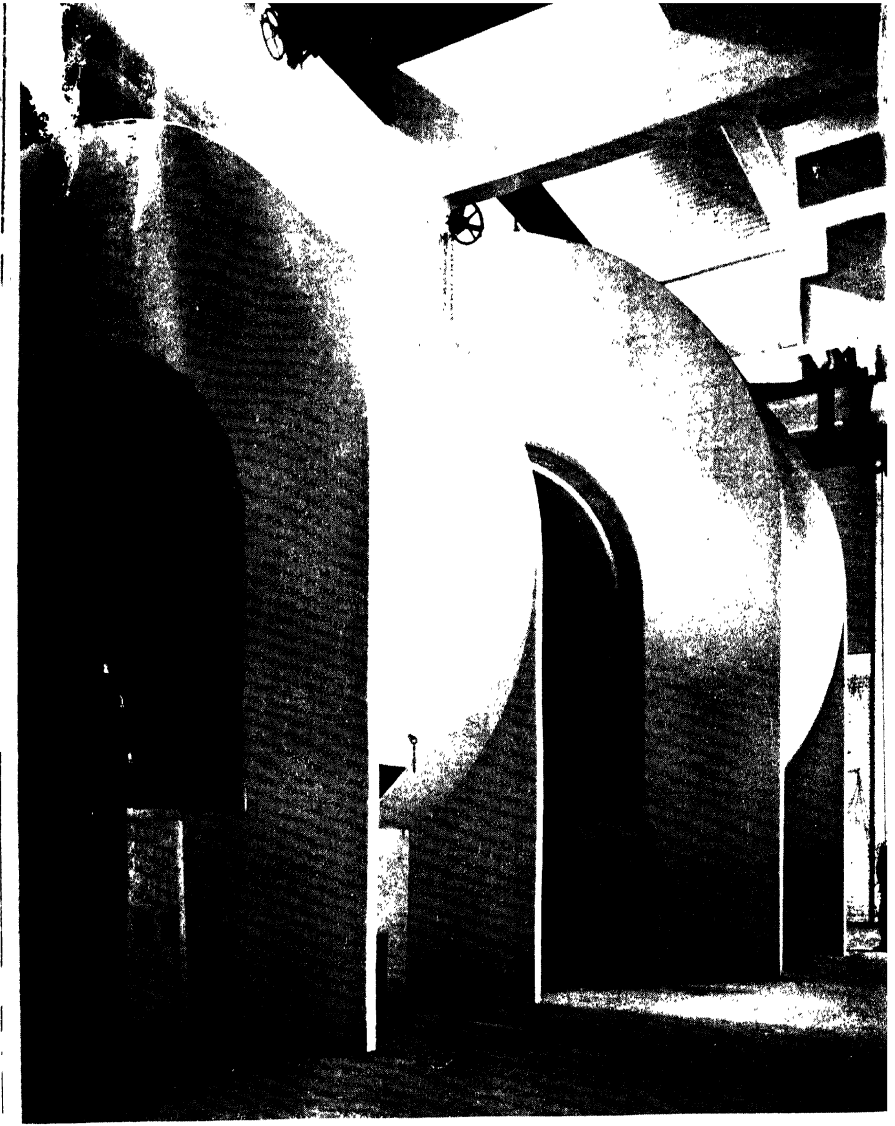


PLATE 44.—Machine architecture. The exhaust fans in one of the ventilating stations of the Mersey tunnel. *Architect:* Herbert Rowse, F.R.I.B.A.

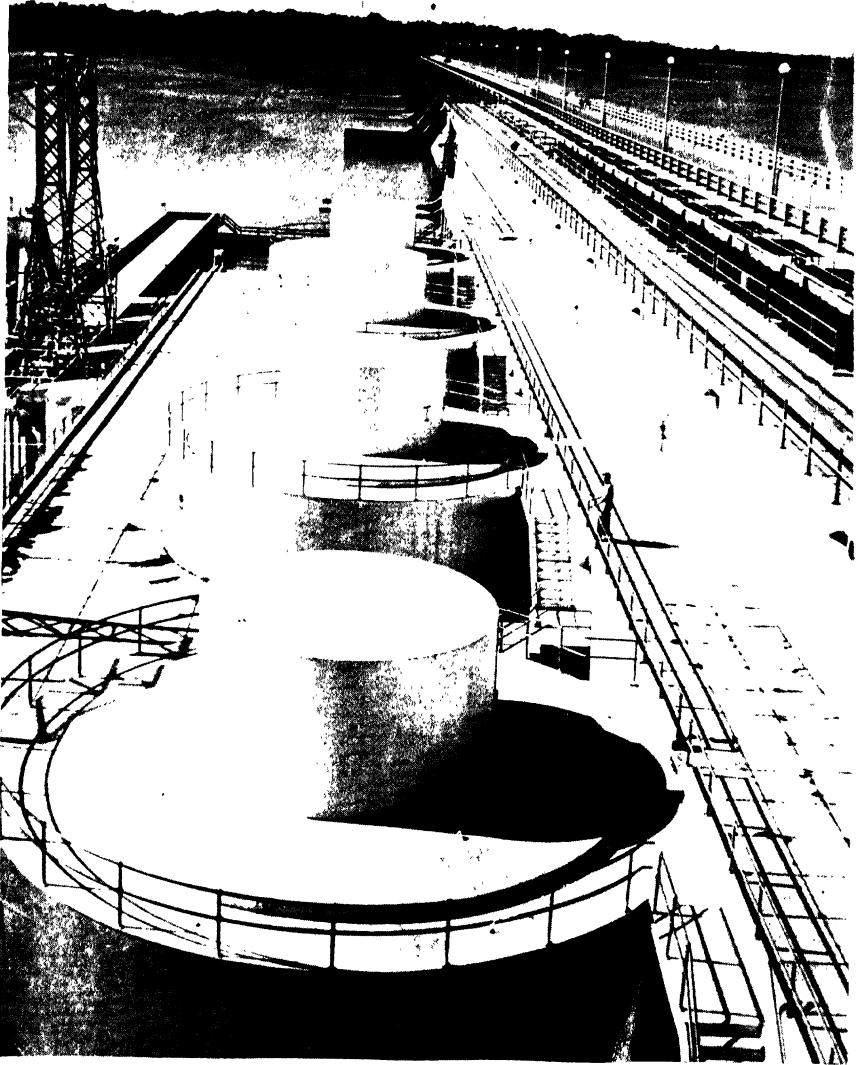


PLATE 45.—Machine architecture. Wheeler dam, the first of the main river dams, built by the Tennessee Valley Authority. This concrete structure is nearly a mile and a quarter in length. The turbines and generators shown here are enclosed in bold cylindrical forms.

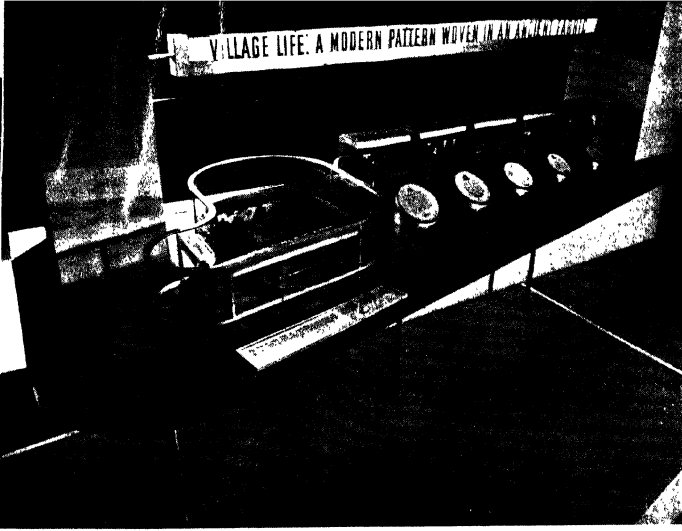


PLATE 48.—Another branch of commercial art is exhibition display. Here are two examples taken from the British Pavilion in the New York World Fair, 1939. *Above* is the Village Life Exhibit in the Social Services Hall, designed by Misha Black. The small anodised aluminium showcases contain dioramas of communal village life in Great Britain—the pub, the flower show, the village hall dance. These dioramas were modelled in wax by Bertha Wright, mirrors being used to create an impression of depth and to give an all-round view, impossible to obtain by normal diorama technique. *Below* is the Public Health Exhibit in the Social Services Hall, designed by Misha Black and Jesse Collins. The showcase is constructed of teak and anodised aluminium. Gay but muted colours are used in the display material. Actual historical exhibits are incorporated as part of the word and picture story of the development of public health services in Great Britain.



DATE OF ISSUE

This book must be returned within 3, 7, 14 days of its issue. A fine of ONE ANNA per day will be charged if the book is overdue.

--	--

