

**BIRLA CENTRAL LIBRARY
PILANI (Rajasthan)**

Class No. 677-13

Book No. S52J

Accession No. 59387

REQUEST

IT IS EARNESTLY DESIRED THAT THE BOOK BE HANDLED WITH CARE AND BE NOT MARKED, UNDERLINED OR DISFIGURED IN ANY OTHER WAY, OTHERWISE IT WILL HAVE TO BE REPLACED OR PAID FOR BY THE BORROWER IN THE INTEREST OF THE LIBRARY.

LIBRARIAN

PUBLISHED BY PITMAN

CALCULATIONS & COSTINGS FOR KNITTED FABRICS

By PROFESSOR WILLIAM DAVIS, M.A., of *University College, Nottingham*.

This is a valuable textbook suitable for students in all stages of hosiery classes. It will also prove useful to those in the industry concerned with costing.

In demy 8vo, cloth, 232 pp. **10s. 6d.** net.

HOSIERY COST ACCOUNTS

By STEPHEN F. RUSSELL, A.C.W.A.

Outlines a system of costing that has been specially designed for use in the hosiery manufacturing trade, and gives clear explanations of general principles, with illustrated examples and practical suggestions that are of value to all who are concerned with modern costing methods.

In demy 8vo, cloth gilt, 176 pp. **10s. 6d.** net.

THE TEXTILE STUDENT'S MANUAL

An Outline of All Textile Processes from the Origin of the Fibre to the Finished Cloth.

By T. WELFORD, *Lecturer on Textiles to the London County Council, London Chamber of Commerce Textiles Prize, 1926.*

A book of reference to all branches of the industry. The book is invaluable to textile students and to all engaged in the textile industry.

In demy 8vo, cloth gilt, 236 pp., illustrated.
7s. 6d. net.

Sir Isaac Pitman & Sons, Ltd., Parker St., Kingsway, W.C.2

JUTE SPINNING CALCULATIONS

BY

ANDREW SMITH

HEAD OF THE SPINNING DEPARTMENT
DUNDEE TECHNICAL COLLEGE

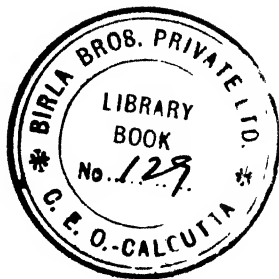

LONDON
SIR ISAAC PITMAN & SONS, LTD.

1935

SIR ISAAC PITMAN & SONS, LTD.
PITMAN HOUSE, PARKER STREET, KINGSWAY, LONDON, W.C.2
THE PITMAN PRESS, BATH
PITMAN HOUSE, LITTLE COLLINS STREET, MELBOURNE
ASSOCIATED COMPANIES
PITMAN PUBLISHING CORPORATION
2 WEST 45TH STREET, NEW YORK
SIR ISAAC PITMAN & SONS (CANADA), LTD.
(INCORPORATING THE COMMERCIAL TEXT BOOK COMPANY)
PITMAN HOUSE, 381-383 CHURCH STREET, TORONTO

PRINTED IN GREAT BRITAIN
AT THE PITMAN PRESS, BATH

PREFACE

THE need for a suitable book dealing in a concise way with the calculations necessary in Jute Spinning has long been very evident. This book, written in an endeavour to supply this need, contains, in addition to the calculations, brief descriptions of the preliminary operations and of those in the preparing and spinning departments, while the mechanisms of the different machines in use are described in sufficient detail to make the different calculations quite clear.

The elementary chapters, I and II, are specially intended for those students and practical men in the trade who may not have much acquaintance with the mathematics and elementary mechanics necessary. In the other chapters the working out of the different calculations has been kept in the simplest form practicable.

It is hoped, therefore, that the book will be of use to all students of Jute Spinning and to those engaged in the practical work of the industry. It should also be of use to students and practical men in Flax Spinning. The methods and reasoning used and also the calculations can easily be applied to Flax Spinning if the difference in the nature of the units employed in the two industries is kept in mind.

A. SMITH

CONTENTS

CHAP.	PAGE
PREFACE	V
I. TRANSMISSION OF MOTION	1
II. SURFACE SPEEDS, DRAFTS, AND LEADS	18
III. PRELIMINARY OPERATIONS	36
IV. CARDING	43
V. DRAWING AND DOUBLING	80
VI. THE ROVING FRAME	119
VII. THE SYSTEM	169
VIII. THE SPINNING FRAME	179
IX. REELING	196
X. TWISTING	202
INDEX	215

JUTE SPINNING CALCULATIONS

CHAPTER I

TRANSMISSION OF MOTION

MOTION is communicated to machines and to their different parts by Wheel Gearing, Belts and Ropes, Screws, Screw and Worm Wheel Gearing, and Cams.

Toothed Wheels

The simplest way of transferring motion from one shaft to another lying parallel with it a short distance away is by the rolling contact of two circular discs with flat edges, one on each shaft, as in Fig. 1. With this arrangement, when one of the shafts is made to rotate uniformly, the friction between the two discs will cause them to roll upon each other and a uniform motion will be given to the other shaft. But no great amount of power could be transmitted in this way; and as the transmission of power is a very necessary condition in textile machinery, this is made possible by providing the discs with teeth which are capable of engaging, those of the one disc with those of the other, and which are so shaped that the motion of the two wheels when working together is quite smooth and is, as nearly as possible, the same as that of the two plain discs in rolling contact. The nature of the shape of tooth required is shown in Fig. 2; the dotted lines represent the outlines of the original plain discs and

2 JUTE SPINNING CALCULATIONS

are called the *pitch circles* of the toothed wheels which have been developed from these discs.

The pitch circle of a toothed wheel is an important factor; the correct rolling contact of two toothed wheels

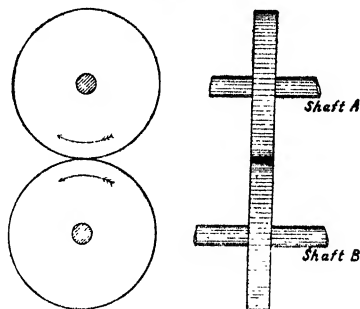

FIG. 1

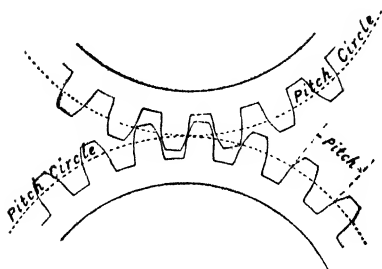

FIG. 2

intended to work together is only obtained when their pitch circles are touching; the value of a wheel in transmitting motion is proportional to its circumference, and this is always taken as that of the pitch circle.

The teeth of a wheel will, naturally, all be made the same size and the same distance apart, and this distance, measured along the pitch circle from a point in

one tooth to the corresponding point in the next, is called the *pitch* of the teeth in the wheel (Fig. 2). As wheels which are to work together must have the same size and pitch of teeth, the number of teeth in each will be proportional to its circumference. In calculations, therefore, where the relative sizes of circumferences of wheels working together are required, it will be quite sufficient, and more convenient, to take the number of teeth in each wheel to represent them.

Geared Wheels

Toothed wheels set so that they can move each other are said to be "in gear"; when set so far apart that the teeth cannot engage, they are said to be "out of gear." Of two wheels in gear, one larger than the other, the larger is usually called the *wheel*, and the smaller the *pinion*. A straight bar provided with teeth which can gear with those of a wheel is called a *rack*.

Fig. 3 shows two toothed wheels, *A* and *B*, in gear, *A* having 36 teeth and *B*, 18. If *A* is rotating uniformly, it will impart a uniform motion to *B*, causing it to rotate uniformly in the opposite direction. No slipping can take place, the teeth in *A* must gear with a like number of teeth in *B*, and the speeds of the *circumferences* of the two wheels must be the same. If *A* makes one revolution, its 36 teeth must gear with 36 teeth of *B*; but *B* has only 18 teeth; it must, therefore, to provide these 36 teeth to gear with the 36 of *A*, make $\frac{36}{18} = 2$ revolutions. Again, if *A* is running at 10 revolutions per minute, 10×36 teeth of *A* must gear with a like number of those of *B* each

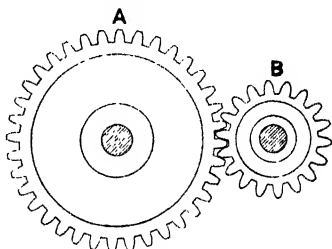

FIG. 3

minute; and *B*, to get this, must make $\frac{10 \times 36}{18} = 20$

revolutions per minute. In these examples the revolutions of the driven wheel have been found by multiplying those of the driver *A* by the number of its teeth and dividing the result by the number of teeth in the driven *B*; and as this method may be applied generally, we may say of two wheels in gear that

- (1) R.p.m. of driver $\times \frac{\text{teeth in driver}}{\text{teeth in driven}} = \text{r.p.m. of driven}$;
 (2) R.p.m. of driver $\times \text{teeth in driver} = \text{r.p.m.} \times \text{teeth in driven}$

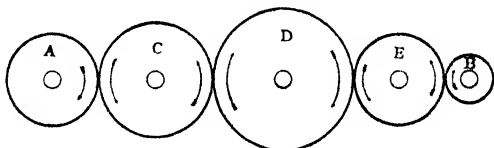

FIG. 4

Evidently the smaller either wheel is, the greater will be its revolutions relatively to those of the other, and the larger it is, the less proportionally will these revolutions be. Two wheels in gear, therefore, will rotate in opposite directions, and their speeds in revolutions per minute will be inversely proportional to their sizes.

Intermediates

When two parallel shafts are so far apart that the wheels on them cannot be brought into gear directly, these wheels may be connected by introducing one or more wheels on separate axles to fill up the gap between them. Wheels used for this purpose are called *carriers* or *intermediates*. Fig. 4 shows, by their pitch circles, two wheels, *A*, 36 teeth, and *B*, 18 teeth, connected in this way by three intermediates, *C*, *D*,

and *E* placed between them. If the circumference of *A* is moved the space of one tooth, that of *C* must move the same, and so also must those of *D*, *E*, and *B*. It will be the same whatever number of teeth the circumference of *A* moves, the circumferences of *C*, *D*, *E*, and *B* must move the same. If, then, *A* is rotated uniformly, the speed of the circumference of *C* must be the same as that of *A*, the speed of the circumference of *D* must be the same as that of *C*, and so on. These three intermediates, therefore, simply carry the circumferential speed of *A* across the gap to *B*; the speeds of the circumferences of *A* and *B* must be the same, and this no matter what the sizes of the intermediates may be. If *A* is making 10 revolutions per minute, its circumference will move a distance of 36×10 tooth spaces in that time, those of *C*, *D*, *E*, and *B* must do the same, and *B*, in order that its circumference may move this distance, must make $10 \times \frac{36}{8} = 20$ revolutions; the revolutions of the driven wheel have been found by multiplying the revolutions of the driver by the number of its teeth and dividing by the number of teeth in the driven, and this is just the same as if the two wheels were directly in gear. Two wheels, then, connected by intermediates will have the same relative speeds as if they were directly in gear; the carriers, or intermediates, between them having no effect on these relative speeds, may be ignored in any calculations with regard to them.

But intermediate wheels may affect the direction of rotation of the wheels which they connect. In Fig. 4 *D* and *B* rotate in the same direction as *A*, while *C* and *E* rotate in the opposite direction; if *E* were removed and *B* made to gear with *D*, *B* would rotate in the opposite direction to *A*; if *D* also were removed and *B* made to gear with *C*, *B* would rotate in the

6 JUTE SPINNING CALCULATIONS

same direction as *A*. That is, with one intermediate between them, *B* and *A* will rotate in the same direction; with two, in opposite directions; with three, in the same direction; and, if four were used, it is obvious that they would again rotate in opposite directions, and so on. To put it shortly and generally, when an even number of intermediates is used between

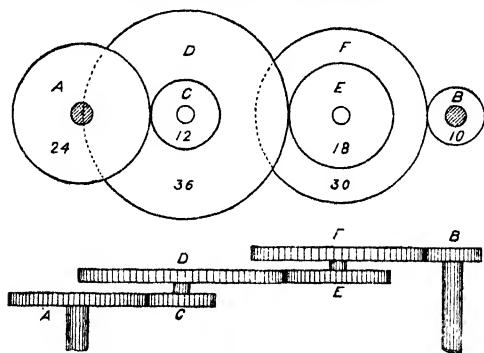

FIG. 5

two wheels, these wheels will rotate in opposite directions; if an odd number be used, they will rotate in the same direction.

Double Intermediates

Often a considerable increase or decrease in the speed of one shaft with regard to another is required; in either case the space between the shafts may be filled by pairs of wheels called *double intermediates*. These consist each of two wheels, one larger than the other, either fixed together or keyed to the same shaft, and so arranged that the larger wheel of one pair gears with the smaller of the pair next to it in the series. Fig. 5 shows, in elevation and plan, an arrangement of this kind with two pairs of intermediates

used when an increase of speed is required; *A*, the driver, gears with *C*, the smaller wheel of the first intermediate pair; *D*, the larger wheel of this pair, gears with *E*, the smaller wheel of the second pair; and *F*, the larger of this second pair, drives *B*. When *A* rotates, its circumferential speed will be communicated to *C*; but it is the circumferential speed of *D* that will be communicated to *E*, and this speed, *D* being a larger wheel than *C* and turning with it, will be higher than that of *C*. *F*, again, rotating with *E* and being larger, will have a greater circumferential speed than *E*, and this speed will be communicated to *B*. The effect of the whole arrangement, called a *train of wheels*, will be to give *B* a much greater circumferential speed than that of *A*.

Taking the sizes of the wheels as given in Fig. 5, if *A* makes 10 revolutions per minute, *C* will make

$$10 \times \frac{24}{12} = 20 \text{ revolutions}$$

in the same time, and *D*, being coupled with *C*, must make the same. *D* will, in turn, drive *E*, and, with it, *F* at

$$20 \times \frac{36}{18} = 40 \text{ revolutions}$$

per minute. Finally, *F* will drive *B* at

$$40 \times \frac{30}{10} = 120 \text{ revolutions}$$

per minute. The whole operation may be combined in one statement thus: *A*, with the gearing between them, will drive *B* at

$$10 \times \frac{24}{12} \times \frac{36}{18} \times \frac{30}{10} = 10 \times 12 = 120 \text{ r.p.m.}$$

Here the revolutions of *B* have been obtained by

multiplying the revolutions of *A* per minute by each driver and dividing by each driven, or

$$\text{R.p.m. of } A \times \frac{\text{product of all drivers}}{\text{product of all driven}} = \text{r.p.m. of } B.$$

When a decrease in speed from one shaft to another is required, the same principle may be followed; but it will be necessary to arrange the double intermediates, or pairs, so that the first driver and the smaller wheel of each pair gears with the larger wheel of the pair next to it in the series. In Fig. 5, for example, if *B* were the driver and *A* the driven, it would be easy to show, as in the first case, that

$$\text{Revolutions of } B \times \frac{\text{product of all drivers}}{\text{product of all driven}} = \text{Revolutions of } A$$

and, as the drivers are now the smaller, the revolutions of *A* must be correspondingly less than those of *B*. Taking *B* as running at 180 r.p.m., the revolutions of *A* in the same time would be

$$180 \times \frac{10}{30} \times \frac{18}{36} \times \frac{12}{24} = \frac{180}{1} \times \frac{1}{12} = 15$$

In both of these cases the revolutions of the first wheel multiplied by the product of all the drivers and divided by the product of all the driven gave the corresponding revolutions of the last wheel in the series; in this calculation the result obtained by dividing the product of the drivers by the product of the driven is called the *value* of the train. We may, therefore, put our statement more shortly thus: In a train of wheels

$$\begin{aligned} &\text{Revolutions of first wheel} \times \text{value of the train} \\ &= \text{Revolutions of last wheel.} \end{aligned}$$

Bevel Wheels

Shafts to be connected by gearing are not always parallel, but are often at an angle to each other—

usually a right angle. When this is so, *bevel wheels*, such as are shown in Fig. 6, may be used to connect them. These are simply developed from two cones, which, as may readily be shown by experiment, will roll on each other without slipping if properly mounted with their points placed together, as in Fig. 7. Instead of the whole cones, a part only of each cone may be used; for example, in Fig. 7 the shaded part *A* of

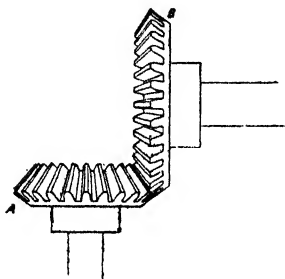

FIG. 6

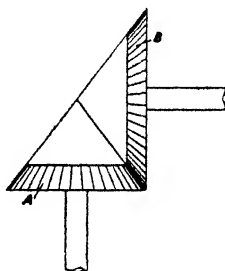

FIG. 7

the one cone and the corresponding part *B* of the other can be used and will work well together. To prevent slipping and so make the drive positive, these two parts may be provided with properly shaped teeth, when bevel wheels, such as those shown in Fig. 6, will be obtained.

The relative speeds of two bevel wheels in gear are easily found; in Fig. 6 the circumferential speed of *A* must, obviously, be the same as that of *B*; from this it follows, as in the case of ordinary wheels, that

$$\text{Revolutions of } A \times \frac{\text{teeth in } A}{\text{teeth in } B} = \text{Revolutions of } B.$$

The relative speeds, then, of the two bevels are the

same as if they were ordinary wheels in gear with the same number of teeth.

Belt Drives

Belts or straps are used to transmit motion from one shaft to another when the shafts are parallel to one another but are at a considerable distance apart. Drums or pulleys are fixed to the two shafts, one on each, and are so set as to be in the same plane; an endless flexible band is stretched over the surfaces of these pulleys and is made sufficiently tight to grip these surfaces. Such an arrangement is shown in Fig. 8, where the pulleys *A* and *B* on the two shafts *D* and *E* are connected by the belt *C*. When one of these shafts is rotated, the belt, being in contact with the circumference of the pulley on it, will be made to travel at the same rate as this circumference, and, as this motion of the belt will be communicated to the circumference of the pulley on the other shaft, the speeds of the belt and of the circumferences of the two pulleys will all be the same. The effect of the belt drive, then, so far as the two pulleys are concerned, is just the same as if their surfaces were in rolling contact, except that the direction of rotation of the two will be the same. This is with an open belt; when the shafts are required to rotate in opposite directions, the belt must be crossed.

In Fig. 8, take *A* as being 36 in. diameter and *B* as 16 in. Then, as the circumference of a circle is always 3.14 times its diameter, the circumference of *A* will be 36×3.14 in. and of *B*, 16×3.14 in. If, now, the shaft *D* is running at 120 revolutions per minute, the speed of the circumference of the pulley *A* will be $120 \times 36 \times 3.14$ in. per minute. This will be the speed of the belt and also of the circumference of the pulley *B*, so that if we divide this speed by the

circumference of B , we shall obtain the corresponding revolutions per minute of B , or

$$\frac{120 \times 36 \times 3.14}{16 \times 3.14} = 270 = \text{revolutions of } B \text{ per minute.}$$

In calculations such as this, involving relative circumferences, the 3.14's will cancel out one another, leaving only the diameters to be taken into consideration, so that, to get the speed of one shaft driven from another

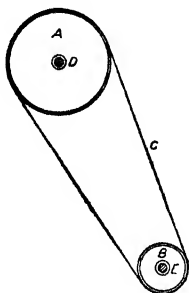

FIG. 8

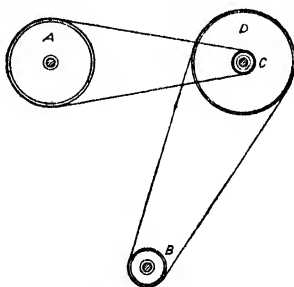

FIG. 9

by a belt, it is simply necessary to multiply the revolutions of the driving shaft by the diameter of the pulley on it and to divide the result by the diameter of the pulley on the driven shaft; or, referring to Fig. 8,

$$\text{Revolutions of shaft } D \times \frac{\text{Diameter of } A}{\text{Diameter of } B} = \text{Revolutions of shaft } E.$$

Obviously, as with two toothed wheels in gear, the relative revolutions per minute of the two shafts will be inversely proportional to the sizes of the two pulleys.

Sometimes, owing to practical difficulties or to the speed of one shaft requiring to be relatively high to that of the other, it is not possible to drive the one directly from the other; in this case a *countershaft*

may be used. This is a shaft placed in a position to be driven conveniently by the first shaft and, in its turn, to drive the second shaft (see Fig. 9). The method may be used to avoid an obstacle to the direct drive or to obtain either an increase or a decrease in speed. If the pulleys on the shafts and countershafts are so arranged that the drivers are all larger than the driven, an increase in speed will be obtained, if arranged so that the drivers are the smaller, a decrease will be obtained.

In the diagram Fig. 9 the pulley *A* on the main shaft is 30 in. diameter and drives the pulley *C*, $7\frac{1}{2}$ in. diameter, on the countershaft. The pulley *D*, 36 in. diameter, also on the countershaft, drives the pulley *B*, 12 in. diameter, on the driven shaft. If *A* runs at 125 revolutions per minute, it will drive *C* at

$$125 \times \frac{30}{7.5} = 500 \text{ r.p.m.}$$

This will also be the revolutions per minute of the pulley *D*, which will in turn drive *B* at

$$125 \times \frac{30}{7.5} \times \frac{36}{12} = 1500 \text{ r.p.m.}$$

If, now, we took the pulley *B* as the driver and *A* as the driven, the calculation to find the relative speed of *A* would be similar to this, but as the drivers would now be the smaller, the result would be a decrease in speed. Taking *B* as running at 1800 revolutions per minute, the revolutions per minute of *A* would be

$$1800 \times \frac{12}{36} \times \frac{7.5}{30} = 150.$$

These calculations would be of the same nature whatever the number of countershafts might be and are evidently the same as in the case of a train of wheels, except that the diameters of the pulleys are used in

place of the number of teeth in the wheels. Just as in that case, therefore, we shall have

$$\begin{aligned} \text{Revolutions of first pulley} \times \frac{\text{product of all drivers}}{\text{product of all driven}} \\ = \text{Revolutions of last pulley.} \end{aligned}$$

Screws

In textile machinery it is often necessary to obtain a forward sliding motion directly from one of rotation ;

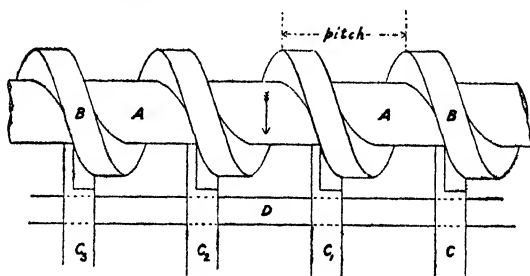

FIG. 10

this is most conveniently done by means of screws. An idea of the form of a screw and of the use to which it may be put is shown by the diagram, Fig. 10. In this diagram the projecting rim *B* running round the central shaft *A* of the screw in a uniformly spaced spiral is the *thread* of the screw ; in contact with the screw thread are movable bars, C_1 , C_2 , C_3 , etc., resting on the fixed slide *D* ; these bars have to be driven forward by the rotation of the screw.

Evidently, when the shaft *A* rotates, the bar *C* will be pressed forward by the projecting thread *B* carried round by the shaft, until, when the shaft has made one complete revolution, *C* will be in the position at first occupied by C_1 , C_1 will be in the position occupied by C_2 , and so on ; that is, each bar will have travelled

a distance equal to the space between two corresponding edges of the screw thread. This distance, from a point on one ridge of the screw thread to a corresponding point on the next, is called the *pitch* of the screw; if, then, the screw rotates uniformly, the bars will all be steadily pushed forward a distance equal to the pitch of the screw for each revolution. For example, if the speed of the screw shaft were 200 revolutions per minute and the pitch of the screw

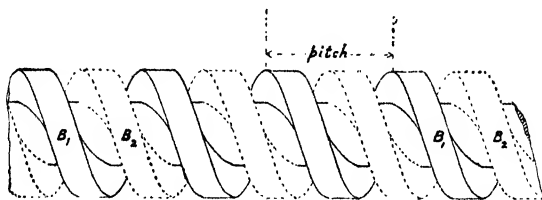

FIG. 11

$\frac{3}{4}$ in., the speed of the bars would be $200 \times \frac{3}{4} = 150$ in. per minute.

In Fig. 10 there is only a single thread B running round the central shaft; it is therefore called a *single-threaded* screw. If we were to add another similar thread in the space left by the first, so as to have two parallel threads wound on side by side, we should then have a *double-threaded* screw, as in Fig. 11. Obviously, we could drive with this double the number of bars, lying at half the distance apart, that we could with the single-threaded screw. Increasing the number of threads in this way makes no difference to the pitch of the screw as this is dependent on one continuous thread; the bars will be driven a distance equal to the pitch of a thread for one revolution of the shaft, but double the amount of bars may be driven.

When used for transmitting motion, screw threads

are always made square shaped so as to give a large bearing surface as nearly as possible at right angles to the direction of the pressure.

Screw and Worm-Wheel

The screw is often used to drive a toothed wheel, the teeth of the wheel used being slightly inclined so

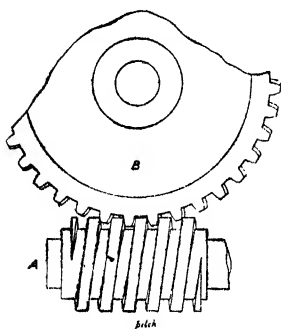

FIG. 12

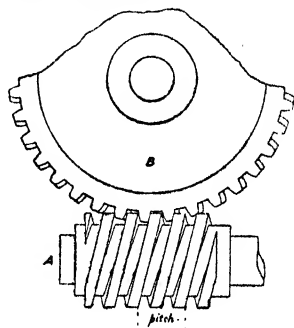

FIG. 13

as to gear with the spaces between the threads of the screw. This arrangement, called the *screw and worm-wheel*, is used when a large reduction in speed is required and there is no room for double intermediates, or where the use of a very small wheel driving a large is impracticable. Fig. 12 shows a screw and part of the worm-wheel with which it is geared. As the screw revolves, the thread will push forward the teeth of the wheel which are in contact with it; other teeth will come into play as these are pushed aside, so that the motion will be continuous. The wheel, therefore, will be slowly and uniformly rotated as the screw rotates, each tooth moving forward a distance equal to the pitch of the screw thread.

If the screw has a single thread as in Fig. 12, the

pitch of the teeth of the wheel will be equal to the pitch of the screw thread, so that one revolution of the screw will move the teeth of the wheel a distance of one pitch, or one tooth, forward. If the wheel *B* had 50 teeth, it would require 50 revolutions of *A* to give it one complete revolution. If, however, the screw were double-threaded, as in Fig. 13, the pitch of the teeth of the wheel would be only *half* the pitch of the screw, and, as the teeth are moved forward a

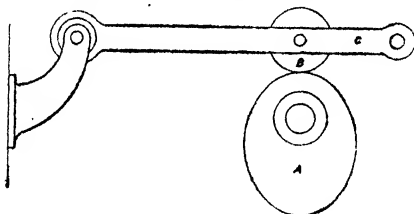

FIG. 14

distance equal to the pitch of a thread for one revolution of the screw, one revolution will drive the wheel *B* two teeth forward. The double-threaded screw, therefore, will require $\frac{50}{2} = 25$ revolutions only to give *B* a complete revolution. Similarly, a three-threaded screw would require only $\frac{50}{3}$ revolutions to give *B* a complete revolution. For purposes of calculation, therefore, it will be most convenient to consider the screw in a screw and worm-wheel gearing as a wheel with teeth equal to the number of threads of the screw; a single-thread screw will be equal to a wheel of one tooth, a double-threaded screw to one of two teeth, and so on.

Cams

Cams are used to give back and forward motion to parts of a machine. They are usually in the form of

plates or discs; when these discs rotate, motion is given to the pieces in contact with them and the nature of this motion depends entirely on the shapes of the edges of the cams or of grooves in their surfaces. The motion obtained may be of a very varied nature and may be made to suit a great variety of circumstances. For example, when the cam *A* in Fig. 14 rotates, the end of the lever *C*, on which is the roller *B* bearing on the edge of the cam *A*, must move up and down in accordance with the shape of *A*. It is easy to see that the shape of *A* and, consequently, the motion of *B* may be varied indefinitely.

CHAPTER II

SURFACE SPEEDS, DRAFTS, AND LEADS

Surface Speed

IF a roller is rotating uniformly, a plank laid across it and free to move would be made to travel forward in the direction the surface of the roller was moving and at the same rate; i.e. a distance equal in length to the circumference of the roller for each revolution. This rate must, obviously, be the same as that of any point on the surface of the roller, and is called the *surface speed* of the roller. The circumference of a circle is always equal to the diameter $\times 3.1416$, the sizes of the rollers used in jute spinning are usually given in inches of diameter, so that the surface speed of a rotating roller will be

$$\begin{aligned} \text{Revolutions per minute} \times \text{diameter of roller} \times 3.1416 \\ = \text{inches per minute} \end{aligned}$$

or, as surface speeds are more conveniently expressed in feet per minute,

$$\begin{aligned} \text{Revolutions per minute} \times \frac{\text{diameter of roller} \times 3.1416}{12} \\ = \text{feet per minute.} \end{aligned}$$

Drafts

While it is necessary to know the actual surface speeds of the rollers in a machine, it is in many cases equally important to know the ratios between the surface speeds of different rollers. In Fig. 15 *A* and *B* are two rollers with pressing rollers *C* and *D* placed above them so as to enable them to grip the ribbon of fibre *E* passing between them. If *A* is running at 120 revolutions per minute and is $2\frac{1}{2}$ in. diameter,

while *B* is running at 20 revolutions and is 2 in. in diameter, then

(a) Surface speed of *A* = $120 \times 2.5 \times 3.14$ in. per min.

(b) „ „ of *B* = $20 \times 2 \times 3.14$ „ „ „

Dividing (a) by (b) we get

$$\frac{120 \times 2\frac{1}{2} \times 3.14}{20 \times 2 \times 3.14} = 7.5$$

that is, the surface speed of *A* is $7\frac{1}{2}$ times that of *B*; the ribbon of fibre, or sliver, will be taken away by *A*

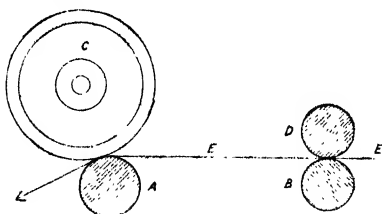

FIG. 15

$7\frac{1}{2}$ times faster than it is being brought forward by *B* and, as a consequence, will be pulled out or elongated to this extent. This pulling out of the sliver is called *drawing* and the extent of it, the *draft*. The term “draft,” however, is often used to denote simply the ratio between the surface speeds of two rollers acting on the same sliver, the ratio of the surface speed of the faster to that of the slower being always taken.

Though, in working out the draft between two rollers, it is quite correct to find the actual surface speeds of two rollers in a machine and then to compare them, in practice it is more convenient and much less roundabout to use the train of gearing connecting them in the machine in order to find first of all the *relative* revolutions of the two rollers and from them the ratio of their surface speeds. In Fig. 16 two rollers, *A*, 10 in.

diameter, and B , 4 in. diameter, are connected by gearing as shown, the wheel k , running at 180 revolutions per minute, being the driver of the whole arrangement; it is required to find the draft between A and B , i.e. how many times the surface of the one goes faster than

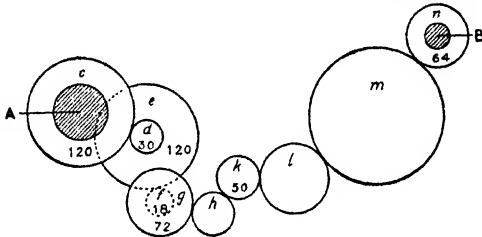

FIG. 16

that of the other. Using the method of comparing actual surface speeds, the surface speed of A will be

$$(a) \frac{180}{1} \times \frac{50}{72} \times \frac{18}{120} \times \frac{30}{120} \times \frac{10 \times 3.14}{1} \text{ in. per min.}$$

and of B

$$(b) \frac{180}{1} \times \frac{50}{64} \times \frac{4 \times 3.14}{1} \text{ in. per min.}$$

dividing the surface speed of B , which is evidently the faster, by the surface of speed A , we have

$$(c) \frac{180}{1} \times \frac{50}{64} \times \frac{4 \times 3.14}{1} \times \frac{1}{180} \times \frac{72}{50} \times \frac{120}{18} \times \frac{120}{30} \\ \times \frac{1}{10 \times 3.14} = 12$$

that is, B is running 12 times faster than A , or the draft between the two rollers is 12. It is quite unnecessary to work out the actual value of the two surface speeds as given by (a) and (b); doing so would, in any case, deprive us of the possibility of cancelling out the common factors and so shortening the working out.

SURFACE SPEEDS, DRAFTS, AND LEADS 21

Next, to use the method of taking the gearing directly connecting the two rollers; in the diagram let us suppose that the roller *A* is running at one revolution per minute; its surface speed will then be

$$(a) 1 \times 10 \times 3.14 \text{ in. per min.}$$

and, with the gearing between the two, it will drive the roller *B* at

$$(b) 1 \times \frac{120}{30} \times \frac{120}{18} \times \frac{72}{64} \text{ r.p.m.}$$

and *B*'s surface speed will be

$$(c) 1 \times \frac{120}{30} \times \frac{120}{18} \times \frac{72}{64} \times \frac{4 \times 3.14}{1} \text{ in. per min.}$$

Dividing (c), the surface speed of *B*, by (a) the corresponding speed of *A*, we get

$$\frac{120}{30} \times \frac{120}{18} \times \frac{72}{64} \times \frac{4 \times 3.14}{1} \times \frac{1}{10 \times 3.14} = 12$$

or *B* has 12 times the surface speed of *A*, as before.

Stated generally, this second method of taking the draft between two rollers connected by gearing is to take the slower as running at one revolution per minute; to find out, by using the train of gearing between the two, the revolutions of the other, and from that its surface speed; and then to divide this speed by the corresponding speed of the first, which, as the first is running at one revolution per minute, will simply be its circumference. In the calculation it will be found that, when one surface speed is divided by the other, the 3.14's cancel out, so that in practice the diameters only need be taken into consideration. For practical purposes, then, the statement of the method may be shortened into

Find the revolutions of the second roller for one revolution of the first from the gearing, multiply this by

the diameter of the second, and then divide by the diameter of the first.

Change Pinions and Draft Constant

It is often necessary, for various reasons, to change the draft on a machine; usually this is done by changing one special wheel in the train, the gearing being so arranged that this may be done quite easily without interfering with the other wheels. In the gearing shown in Fig. 16, for example, d is the wheel that may be changed in order to change the draft; on that account it is known as the *change* or *draft pinion*. Calling this wheel DP in the calculation for the draft instead of by the number of its teeth, we shall have

$$\frac{120}{DP} \times \frac{120}{18} \times \frac{72}{64} \times \frac{4}{10} = \frac{360}{DP} = \text{draft between } A \text{ and } B$$

this draft varying with the size of DP . This number, 360, which is simply the result obtained by working out the figures in this particular calculation which do not change, is called the *constant*. We have seen that by dividing it by the value of DP we obtain the draft, or $\frac{\text{Constant}}{DP}$ · Draft. It will be shown a little later

that, when this is so, $DP \times \text{Draft} = \text{Constant}$, and $DP = \frac{\text{Constant}}{\text{Draft}}$.

In the above calculation the draft pinion is on the bottom line of the calculation; it may, however, be on the top. If, for example, in Fig. 16 the wheel g were the change pinion instead of d , the figures for the draft would be

$$\frac{120}{30} \times \frac{120}{18} \times \frac{DP}{64} \times \frac{4}{10} = \frac{DP}{6} = \text{Draft}$$

and $\frac{1}{6}$, being then the value of the figures in the calculation which do not change, would be the constant.

This difference in the nature of the constant when the change pinion is on the top line and when on the bottom should be particularly noted.

Lead

When the surface speed of a roller—or a set of sliding bars—is only slightly faster than that of another, the *amount* that the one goes faster than the other is taken into consideration and is called the *lead*; it is usually conveniently expressed as a percentage reckoned on the speed of the slower. For example, if one roller has a surface speed of 200 in. per minute and another a surface speed of 206 in.; then, while the surface of the first travels 200 in., that of the second will travel 6 in. more; or the lead of the second will be 6 in.

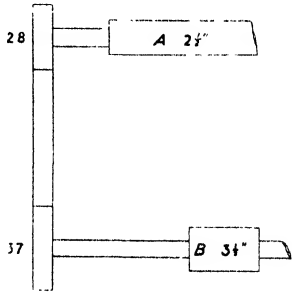

FIG. 17

on 200, 3 on 100, or 3 per cent. Sometimes the actual difference between the surface speeds of the two rollers is given as the lead, without any mention of the speed of either; this may be misleading and should not be done. It gives no real information, and, in any case, the amount of the lead will vary, though not the ratio, if the speeds of the two rollers are proportionally altered. Taking our example again, the lead may be given as simply 6 in.; but should the speed of the rollers be doubled to 400 and 412 in. per minute, the lead would then be 12 in., though the ratio, 3 per cent on the speed of the slower, would be still the same.

In Fig. 17 we have the roller *A*, $2\frac{1}{2}$ in. diameter, driving, by means of gearing, the roller *B*, $3\frac{1}{2}$ in. diameter; it is required to find the lead of the roller *B*,

expressed as a percentage, or, simply, how many inches more the surface of B will travel, while that of A travels 100 in. If A is running at one revolution per minute, its surface speed will be

$$(a) 2.5 \times 3.14 \text{ in. per min.},$$

the corresponding speed of B , with the gearing between, will be

$$(b) \frac{28}{37} \times \frac{3.5 \times 3.14}{1} \text{ in. per min.}$$

Dividing (b) by (a), we get

$$(c) \frac{28}{37} \times \frac{3.5 \times 3.14}{1} \times \frac{1}{2.5 \times 3.14} = 1.06$$

which is the distance in inches B will travel for each inch A travels. Multiplying this by 100 we have

$$(d) \frac{28}{37} \times \frac{3.5 \times 3.14}{1} \times \frac{1}{2.5 \times 3.14} \times \frac{100}{1} = 106 \text{ inches, nearly}$$

or B will travel 106 in. while A travels 100 in., which is, simply, a lead of 6 per cent.

To take a more complicated example, in Fig. 18 the roller A , 2 in. diameter drives, through the gearing $\frac{C}{D} \times \frac{E}{F} \times \frac{G}{H} \times \frac{K}{L}$, the screw M of $\frac{1}{2}$ in. pitch which drives forward the set of bars B, B_1, \dots . It is required to find the lead of the bars over the roller, or how many inches more the bars will travel when the surface of the roller A has moved 100 in. If A makes one revolution, its surface will travel

$$(a) 2 \times 3.14 \text{ in.}$$

and, by means of the gearing, the bars will be driven

$$(b) \frac{75}{25} \times \frac{72}{24} \times \frac{22}{22} \times \frac{24}{16} \times \frac{1}{2} \text{ in.}$$

Dividing (b) by (a), we have

$$(c) \frac{75}{25} \times \frac{72}{24} \times \frac{22}{22} \times \frac{24}{16} \times \frac{1}{2} \times \frac{1}{2 \times 3.14} = 1.07$$

and this is the *number of times* the travel of the bars is greater than that of the surface of the roller *A* ; so that

when *A* travels 1 in., the bars will travel 1.07 in.

.. *B* .. 100 in., 107 in.

or the bars will have a lead of 7 per cent.

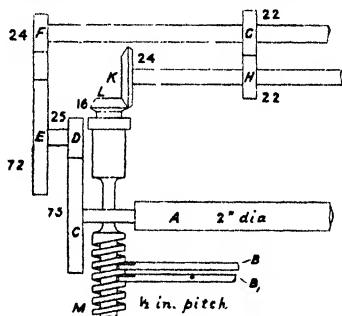

FIG. 18

Equations

In addition to the simple working out of surface speeds, drafts, and leads from the wheels actually in use, it is often necessary to find the sizes of drums, pulleys, or wheels required to give certain surface speeds, revolutions per minute, drafts, etc. In such cases the easiest method is to set down the calculation in the form known as an *equation* ; from this the required result may be easily calculated.

An equation is simply a statement that two expressions are equal, but in it there is at least one unknown quantity, the value of which, to make the statement true, may be calculated from the equation. In jute

spinning calculations the only kind of equation we are likely to meet with in ordinary practice is that with one unknown quantity.

To take an example, in Fig. 19 the drum D is fixed to a shaft A running at 192 r.p.m. and drives a pulley P , 24 in. diameter fastened to the central shaft B of a cylinder C , 48 in. diameter. We have to find what

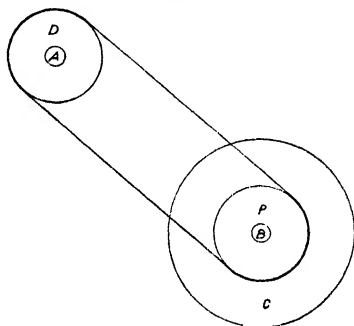

FIG. 19

diameter the drum D must have to drive the cylinder C so that its surface speed will be 2400 ft. per minute.

Taking the drum D , the diameter of which is to be found, as simply D , and setting down the necessary details to give the surface speed of the cylinder on the one side, and the value we wish it to be on the other, and putting an equality sign ($=$) between them, we get

$$192 \times \frac{D}{24} \times 48 \times 3.14 \times \frac{1}{12} = 2400$$

R.p.m. of shaft.....

R.p.m. of cylinder.....

Surface speed of cylinder in inches.....

“ “ “ “ in feet..... = required surface speed

This statement makes the complete equation, D being the unknown quantity; from it the value of D may readily be calculated. In working out or "solving" equations, however, the operations are not quite those of ordinary arithmetic, and as the forms of equations vary and require different methods, it will be better, before going further, to see how different forms of simple equations are worked out.

Solution of Simple Equations

An equation is always in the form of two expressions, one on the one side and the other on the other side of a sign of equality showing that they are equal. In the solving of the equation the two sides may be considerably changed, but the essential thing to remember is that they must be kept equal in value; whatever is done to the one side must be done to the other, and so long as this is done they will remain equal. We may add the same amount to both sides, subtract the same amount from both, multiply or divide both by the same number and they will still remain equal, and it is possible by doing one or more of these things to simplify and solve the equation.

In the equation, $w + 6 = 400$, $w =$ the weight of jute in a bale, $6 =$ the weight in pounds of the bale ropes, $400 =$ the weight of the finished bale in pounds, and we have to find the value of w . If we were to put these on a scale, the jute and ropes on the one side and 400 lb. on the other, they would balance; but if we were to take away the 6 lb. of ropes from the one side, we should have to remove 6 lb. of weight from the other side in order to keep the balance even and so should be left with w on the one scale equal to $400 - 6 = 394$ lb. on the other. The working out of the equation would be stated thus

$$w + 6 = 400 \quad . \quad . \quad . \quad . \quad (1)$$

Deduct 6 from both sides

$$w + 6 - 6 = 400 - 6 \quad \dots \quad (2)$$

$$w = 394 \quad \dots \quad (3)$$

In another equation, $w - 6 = 394$, w = the weight of the finished bale, 6 is the weight in pounds of the bale ropes, and 394 is the weight in pounds of the jute in the bale. When placed on the scale, the bale without the ropes ($w - 6$) would balance 394 lb. on the other. If the ropes were now added to the jute, we should have to add 6 lb. to the other side to keep the balance equal and so should have the complete bale, w , equal to $394 + 6 = 400$ lb. The working out of the equation would read

$$w - 6 = 394 \quad \dots \quad (1)$$

Add 6 to both sides,

$$w - 6 + 6 = 394 + 6 \quad \dots \quad (2)$$

$$w = 400 \quad \dots \quad (3)$$

From the above we may see, then, that when the unknown quantity has a certain amount added to or subtracted from it, the equation may be solved by subtracting this amount from or adding it to both sides, as the case may be. In practice the working out of the above equations may be shortened by omitting step (2) and the operations carried out quite mechanically as thus

$$(1) \quad \begin{aligned} w + 6 &= 400 \\ w &= 400 - 6 = 394 \end{aligned}$$

$$(2) \quad \begin{aligned} w - 6 &= 394 \\ w &= 394 + 6 = 400 \end{aligned}$$

similarly if

$$(3) \quad \begin{aligned} B + 24 &= 360 \\ B &= 360 - 24 = 336 \end{aligned}$$

$$(4) \quad \begin{aligned} B - 24 &= 360 \\ B &= 360 + 24 = 384 \end{aligned}$$

It will be seen in these examples that

in No. 1	6	was	+	when on the left and	-	when on the right
„ No. 2	6	„	-	„	+	„
„ No. 3	24	„	+	„	-	„
„ No. 4	24	„	-	„	+	„

In each case the figure has simply been carried from one side to the other and its sign changed. Hence, in working out an equation, any figure may be changed from the one side of the equation to the other (transposed) if its sign be changed.

In the equation, $B \times 6 = 2400$, $B \times 6$ may represent six similar bales of jute, and 2400, their weight in pounds. If these were placed on the scales, they would balance; but we may look on the 2400 lb. as six different weights of $\frac{2400}{6} = 400$ lb. each. Then, obviously, if 6 bales weigh 6 weights of 400 lb. each, then one bale will weigh 400 lb. To put the working out in proper form,

$$B \times 6 = 2400 \quad . \quad . \quad . \quad . \quad (1)$$

dividing both sides by 6

$$\frac{B \times 6}{6} = \frac{2400}{6} \quad . \quad . \quad . \quad . \quad (2)$$

$$B = 400 \quad . \quad . \quad . \quad . \quad (3)$$

With practice, a step in this working out may be omitted; in line (2) the left side may be taken for granted and the working made to read

$$B \times 6 = 2400$$

Dividing both sides by 6

$$B = \frac{2400}{6} = 400$$

Next we may find the unknown quantity in an equation divided by a number, as in the equation,

$\frac{B}{4} = 100$, which might be taken as saying that one-fourth of a bale is equal to 100 lb. Evidently, if one-fourth of a bale is 100 lb., the bale itself must be four times that, or $100 \times 4 = 400$ lb.; to solve the equation we have simply multiplied both sides by 4

$$\frac{B}{4} = 100$$

Multiplying both sides by 4

$$\frac{B}{4} \times 4 = 100 \times 4$$

$$B = 400$$

Again, as in the previous example, we may shorten the operation by omitting the second step.

The two preceding examples were of equations where the unknown quantity is either multiplied or divided by a number, and a single operation, dividing or multiplying each side by that number, was all that was necessary to solve the equation. In jute spinning, however, equations have very frequently the unknown quantity both multiplied and divided by different numbers. Take, for example, the equation, $B \times \frac{3}{4} = 300$, 3 being the number multiplying the unknown quantity, and 4 the number dividing it; to solve the equation in such cases it is necessary to divide both sides by the multiplying number and then to multiply them by the dividing number,

$$\frac{3}{4} \times B = 300$$

Dividing across by 3

$$\frac{3}{4} \times B \times \frac{1}{3} = \frac{300}{3}$$

$$\frac{B}{4} = 100$$

Multiplying across by 4

$$\frac{B}{4} \times 4 = 100 \times 4$$

$$B = 400$$

The unknown quantity itself may be a divisor, as in the equation $\frac{3}{D} = \frac{4}{60}$. In a case such as this treat the unknown quantity simply as a number and multiply across by it; then proceed as before

$$\frac{3}{D} = \frac{4}{60}$$

Multiply across by D

$$\frac{3}{D} \times \frac{D}{1} = \frac{4}{60} \times \frac{D}{1}$$

$$3 = \frac{4 \times D}{60} \quad . \quad . \quad . \quad . \quad . \quad (1)$$

Multiply across by 60

$$3 \times 60 = \frac{4 \times D}{60} \times \frac{60}{1}$$

$$3 \times 60 = 4 \times D \quad . \quad . \quad . \quad . \quad . \quad (2)$$

Divide across by 4

$$\frac{3 \times 60}{4} = \frac{4 \times D}{4}$$

$$45 = D \quad . \quad . \quad . \quad . \quad . \quad (3)$$

In the above working out we obtained after step (2) the result, $3 \times 60 = 4 \times D$; that is, on the left we have the top of the left hand fraction of the equation multiplied by the bottom of the right, and on the right, the top of the right hand fraction multiplied by the bottom of the left. Evidently this result could have been obtained by simply cross-multiplying these at first, thus

$$\frac{3}{D} \times \frac{4}{60}$$

and this method may be used to simplify any equation in which one or both sides are separated into top and bottom parts by a division line, the commonest form, probably, in spinning calculations. As a matter of convenience in practice it is better, when solving equations such as these, to state whole numbers as fractions in order to avoid confusion—to call 120 (say) $\frac{120}{1}$.

A few examples will show the use of the foregoing method of solving equations in practice.

1. In a draft calculation a few pages back we found that the constant divided by the draft pinion gave the draft; putting this as an equation and stating both sides as fractions, we have

$$\frac{\text{Constant}}{DP} = \frac{\text{Draft}}{1} \quad (1)$$

Multiplying across, we get

$$\text{Draft} \times DP = \text{Constant} \quad (2)$$

and dividing across by the draft

$$DP = \frac{\text{Constant}}{\text{Draft}} \quad (3)$$

2. Taking the equation we obtained (page 26) from the details given in Fig. 19,

$$192 \times \frac{D}{24} \times 48 \times 3.14 \times \frac{1}{12} = 2400$$

First stating the whole numbers as fractions, this equation becomes

$$\frac{192}{1} \times \frac{D}{24} \times \frac{48}{1} \times \frac{3.14}{1} \times \frac{1}{12} = \frac{2400}{1} \quad (1)$$

Cross-multiplying, we get

$$192 \times D \times 48 \times 3.14 \times 1 \times 1 = 2400 \times 1 \times 24 \times 1 \times 1 \times 12 \quad (2)$$

Dividing across by the numbers multiplying D ,

$$\frac{192 \times D \times 48 \times 3.14}{192 \times 48 \times 3.14} = \frac{2400 \times 24 \times 12}{192 \times 48 \times 3.14} \quad (3)$$

$$D = \frac{2400 \times 24 \times 12}{192 \times 48 \times 3.14} = 23.9 \text{ nearly} \quad (4)$$

The step (3) may conveniently be omitted and (4) written down directly.

3. Referring to Fig. 17 and the relative calculation on page 24; suppose it were necessary to make the roller B have a lead of $2\frac{1}{2}$ per cent over the roller A , we should then have to find out what size of wheel will be required to take the place of the wheel 37 at present on B . To have the required lead of $2\frac{1}{2}$ per cent, the roller B will have to go 102.5 in. while A goes 100 in., that is, the surface speed of B must be 1.025 times that of A . Taking the wheel to be used instead of the 37 on the roller B as CP , we shall have (see page 24)

$$\frac{28}{CP} \times \frac{3.5 \times 3.14}{2.5 \times 3.14} = \text{ratio of surface speed of } B \text{ to that of } A.$$

As this is to be 1.025, or $\frac{102.5}{100}$, we get the equation,

$$\frac{28}{CP} \times \frac{3.5 \times 3.14}{2.5 \times 3.14} = \frac{102.5}{100}$$

Cancelling out the 3.14's and cross-multiplying

$$CP \times 2.5 \times 102.5 = 28 \times 3.5 \times 100;$$

whence, dividing across by the numbers multiplying CP

$$CP = \frac{28 \times 3.5 \times 100}{2.5 \times 102.5} = 38.$$

In this type of equation the operations may be simplified and the process carried out mechanically as follows: State the equation wholly as fractions, then

suppose the cross-multiplication to have been done and make the unknown quantity equal to

$$\frac{\text{the numbers which do not multiply it in the cross-multiplication}}{\text{the numbers which multiply it.}}$$

The two following examples will serve to show this shortened method—

1. With the unknown quantity on the top line of the equation,

$$200 \times \frac{D}{16} \times \frac{10}{1.25} = 2800$$

Stated wholly as a fraction, this becomes

$$\frac{200}{1} \times \frac{D}{16} \times \frac{10}{1.25} = \frac{2800}{1} \quad (\text{The lines in this indicate the cross multiplication.})$$

then

$$D = \frac{\text{numbers which do not multiply it}}{\text{numbers which do}} = \frac{16 \times 1.25 \times 2800}{200 \times 10} = 28.$$

2. With the unknown quantity on the bottom line of the equation,

$$\frac{75}{25} \times \frac{72}{24} \times \frac{40}{DP} \times \frac{2.5}{2} = 7.5$$

Stating this in fractions, we get

$$\frac{75}{25} \times \frac{72}{24} \times \frac{40}{DP} \times \frac{2.5}{2} = \frac{7.5}{1}$$

$$\begin{aligned} DP &= \frac{\text{numbers which do not multiply it}}{\text{numbers which do}} \\ &= \frac{75 \times 72 \times 40 \times 2.5}{25 \times 24 \times 2 \times 7.5} = 60 \end{aligned}$$

Another type of equation that may be mentioned is one with a number of terms on each side and the unknown quantity appearing in more than one term. In this case the terms containing the unknown quantity

should all be brought to the left side of the equation and the known quantities to the right, changing the signs as necessary. When simplified, the equation may be readily solved. For example

$$3D + 6 = 41 - 4D$$

Bringing all the D 's to the left side and the known quantities to the right and changing the signs accordingly, we have

$$3D + 4D = 41 - 6$$

$$7D = 35$$

$$D = 5.$$

CHAPTER III

PRELIMINARY OPERATIONS

BEFORE proceeding with the calculations relating to jute spinning, it will be advisable to give a short description of the preliminary treatment given to the jute in the batching room in order to make it fit for spinning.

Jute, as received, is in the form of 400 lb. bales, each made up of large handfuls or *heads* of jute and pressed very compactly together by powerful presses, in order that it may take up as little room as possible during shipment and so save freight. When the jute is to be used, the bales are brought from the warehouse into the batching room in lots of six to twelve bales, or even more, each lot made up of the necessary number of bales of the different marks required for the particular quality of yarn that is to be made. The ropes are cut off the bales and laid aside for separate treatment, and the bales are then broken up.

Bale Opening

Owing to the tremendous pressure which has been used in packing them, the bales are very hard and, when broken up, the layers of jute into which they separate are so hard as to be more like wooden boards than anything else, and are very difficult to handle. These layers are, therefore, softened, opened out, and so made more workable by passing them through a machine called a *bale opener*. This machine has usually one or more rollers, either heavy in themselves or heavily loaded, resting on other rollers placed beneath them in the machine. These rollers have either

large knobs or deep flutes on their surfaces so that the hard layers of jute from the bales, when passed between them, are so crushed and bent that the stiffness is taken out of them and they are made sufficiently soft and open to be easily handled and split up. While being put through the bale opener, it is important that heads from each kind of jute should be taken in rotation and in the same proportion as the number of bales of each kind in the batch; in this way the different kinds of jute in the batch will be properly mixed from the very beginning of the operations.

Piecing Out

After passing through the bale opener, the heads, which are much too bulky to be dealt with in the subsequent operations, are split up by the *strickers up* into handfuls or *stricks* weighing from about 2 lb. to 2½ lb. each, according as the jute is shorter or longer. This uniformity in the size of the stricks is necessary to ensure evenness of treatment in the softener and also to enable the feeder at the breaker to spread the jute evenly on the feed cloth. During the piecing out the strickers-up may keep back any bad-coloured or faulty jute which otherwise might spoil the yarn.

Batching

Jute, being a hard, smooth-surfaced, somewhat woody fibre, has not naturally much spinning quality and, if sent forward in its natural state to be carded and spun, would make a rather hairy yarn at the expense of a very heavy waste. It must, therefore, be adapted for spinning by *softening*, that is, by bending the stricks back and forward under pressure to break down their wiriness and stiffness; and by *batching*, or adding oil and water to it, to give it cling, suppleness, and spinning quality. The two operations are usually

carried out on one machine, the *softener*, the oil and water being added as the jute passes through this machine.

The Softener

The softener has a series of pairs of rollers—63 pairs on an average—arranged along the machine, each pair consisting of a top and bottom roller. These rollers are about 5 in. in diameter and are deeply fluted spirally, the direction of the spirals being changed with each pair of rollers along the machine, so that as great an amount of bending as possible is given to the jute passing through. The top roller of each pair is pressed down on the bottom roller by adjustable springs; a distance piece between the two rollers, however, keeps them slightly apart, so that the points of the flutes of one roller will not at any time bear on the bottoms of the flutes of the other, thus preventing any possibility of cutting the jute by the rollers running “hard to hard.” The rollers are driven by bevels on two side shafts, one pair from either side alternately, these side shafts being, in turn, driven by a cross shaft at the end of the machine. On the cross shaft are fixed the driving pulleys (see Fig. 20).

The jute is run through the softener at the rate of about one ton per hour, the speed of the rollers being about 40 revolutions per minute. At approximately one-third of the way along the machine the oil and water are added by means of an apparatus designed to deliver them uniformly and at a definite rate on to the jute passing through. As they come from the machine the stricks of jute are twisted and piled on barrows, which are then set aside for at least twenty-four hours to allow the oil and water to soak into the fibre; the jute is then ready for carding. Should, however, the roots of the jute stricks require special

treatment, this is attended to before the jute is piled on the barrow, the bad roots being usually snipped off

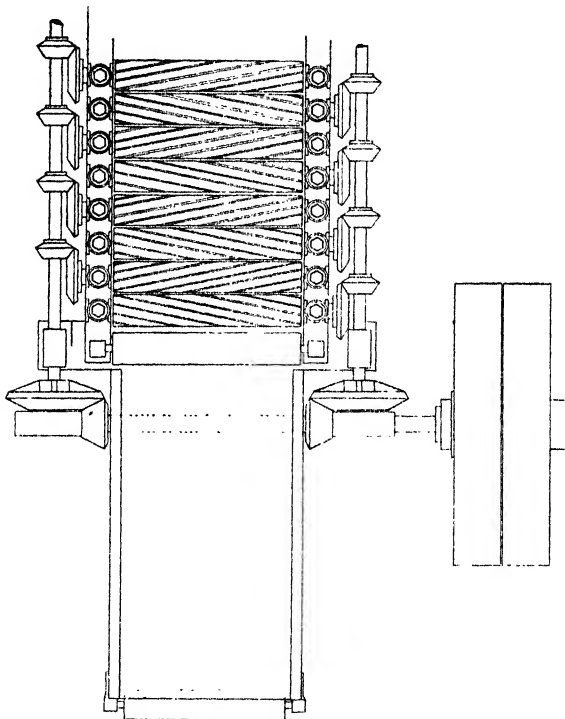

FIG. 20

on a large, broad knife mounted on a stand for the purpose.

Amount of Water and Oil Added

The amount of oil and water added to the jute varies with the circumstances, but 3 to 4 per cent of

40 JUTE SPINNING CALCULATIONS

oil and 15 to 20 per cent of water are about usual—the percentage being calculated on the weight of the raw jute. The actual quantity to be added in a particular case may be calculated as follows—

Taking a 12-bale batch of jute to which are added 15 per cent of water and 4 per cent of oil, the weight of the raw jute would be

$$400 \times 12 = 4800 \text{ lb.}$$

15 per cent of water, i.e. 15 lb. of water for each 100 lb. of jute, will be

$$\frac{4800}{100} \times \frac{15}{1} = 720 \text{ lb.}$$

As a gallon of water weighs 10 lb. the quantity of water required will be

$$\frac{720}{10} = 72 \text{ gallons}$$

Again, 4 per cent of oil on 4800 lb. will be

$$\frac{4800}{100} \times \frac{4}{1} = 192 \text{ lb.}$$

A gallon of oil weighs on an average 9 lb.; the quantity of oil required therefore will be

$$\frac{192}{9} = 21.3 \text{ gallons.}$$

The total weight of the jute after treatment will work out at

Jute	4800 lb.
Water	720 lb.
Oil	192 lb.
						5712 lb. = 51 cwt.
Total	

Moisture in Jute

Before finishing this chapter on the batching operations, a word or two may be said about the moisture

in jute. In ordinary air-dry conditions jute contains about 13 per cent of moisture, but it may contain a quite considerable amount more without the fact being very noticeable. The figure 13 has been suggested as a reasonable standard for the percentage of moisture in jute as, in this condition, neither mildew nor heart damage are likely to develop, and the fibre will neither gain nor lose weight under ordinary conditions of storage. No standard of any kind, however, has been adopted, and jute, as generally imported, seldom contains less than 13 per cent of moisture and may contain as much as 24 per cent.

The true value of the jute, evidently, will vary directly with the amount of actual fibre in it. Supposing that the standard of contained moisture had been fixed at 13 per cent, the proportion of bone dry jute in a bale containing this amount would be $\frac{87}{100}$ ths of the whole. Now take a bale weighing 400 lb. and containing $22\frac{1}{2}$ per cent of moisture; if made thoroughly dry—by heating the jute at 220° to 230° F. until the weight is constant—this would work out at

Weight of bale	400 lb.
Moisture ($4 \times 22\frac{1}{2}$)	90 lb.

Dry jute	<u>310 lb.</u>

If the permissible amount of moisture were only 13 per cent, the weight of a bale containing 310 lb. of actual dry jute should be

$$\frac{310}{1} \times \frac{100}{87} = 356.3 \text{ lb.}$$

The invoiced weight of the bale being 400 lb. the overcharge would be $400 - 356.3 = 43.7$ lb., or 10.92 per cent.

It should be noted that the overcharge cannot be

ascertained by simply deducting the standard percentage from the percentage of moisture in the bale; in the above case, for example, the actual moisture, $22\frac{1}{2}$ per cent, less the standard, 13 per cent, would only come to $9\frac{1}{2}$ per cent overcharge instead of 10.92 per cent, the actual figure.

CHAPTER IV

CARDING

Objects and How Attained

THE objects of *carding* are to turn the long strips of jute fibre, such as we receive them, into a continuous, broad ribbon of fine fibres; this ribbon must be as uniform in size and texture as possible, have a definite weight for a definite length, and contain all the different kinds of jute in the batch uniformly mixed.

Usually two machines are employed, the *breaker* and the *finisher* cards. The material is first broken down, *hackled* or *fleeced out* on the breaker card, and emerges from it as a broad ribbon of comparatively fine fibres, which is called a *sliver*. Ten or twelve of these slivers from the breaker card are next run side by side into the finisher card, where the process is repeated with finer details and the fibres are combed or carded down to the fineness required for the yarn to be made, emerging again in the form of a ribbon or sliver. A definite weight for a definite length of sliver is obtained by weighing off the jute, to begin with, into bundles of uniform weight called *dollops* and spreading each of these evenly on the feed cloth of the breaker while the surface of the feed roller travels a definite distance. This distance is indicated by a pointer which moves round a fixed dial and is driven by gearing from the feed roller. When the pointer moves through one revolution, the corresponding travel of the surface of the feed roller is known and the weight of the dollop is adjusted to give the weight of sliver required. The running together, side by side, of a number of slivers from the breaker card to form the finisher card

feed, makes for levelness and ensures a thorough mixing of the different materials used.

Breaker Card

Fig. 21 is a sectional outline of a breaker card showing all the rollers in position, with their names and their directions of rotation. There are, first, the *cylinder* supported at the centres of the heavy gables of the machine; then the other rollers, the *feed*, two pairs of *strippers* and *workers*, and the *doffer*, all arranged round the cylinder and supported by brackets on the ring of the gable; and lastly, the *drawing rollers* and *delivery rollers* carried on brackets projecting from the front of the gable.

The cylinder, feed roller, strippers, workers, and doffers are the organs which carry out the carding and, as will be seen from the sketch, are furnished with short, sharp, steel spikes or *pins*. These pins are set at definite angles and in the directions shown, the angle of pin for each different roller being: Cylinder, 72° to 75° ; Feed roller, 60° ; Workers and Doffers, 30° to 36° ; and Strippers, 36° to 40° . The surface speeds of the cylinder and rollers are usually as follows—

Cylinder . . .	2400 to 2700 ft. per min.
Feed roller . . .	About 1/200th of the cylinder speed, or 12 to 15 ft. per min.
Workers . . .	36 to 48 ft. per min.
Strippers . . .	300 to 480 ft. per min.
Drawing roller . . .	From 8 to 14 times the speed of the feed, or 150 to 190 ft. per min.
Doffer	Half the speed of the drawing roller.

To suit different requirements, the speeds of the cylinder and the rollers, excepting the doffer, may be varied within the limits mentioned; but the ratio of the speed of the drawing rollers to that of the doffer must always be about 2 to 1, the limits in practice being 1.8 to 1 and 2.2 to 1.

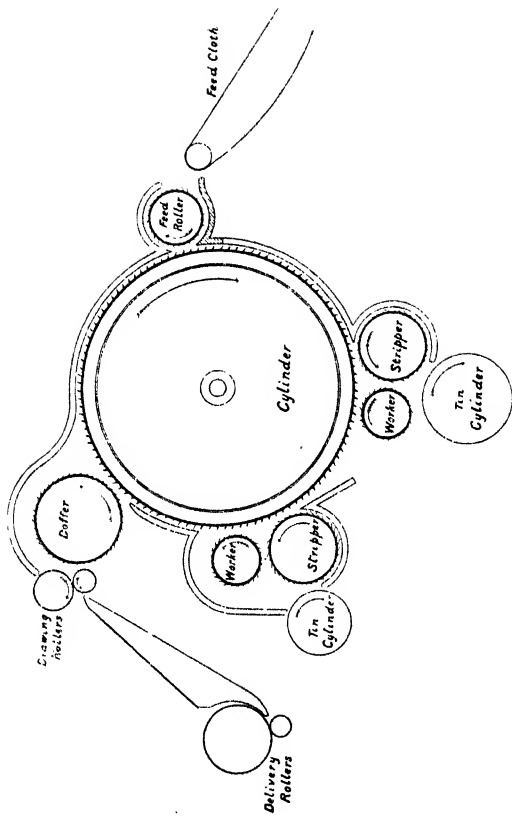

FIG. 21

Action of the Breaker Card

The action of the breaker card on the material passing through it may be described shortly as follows—

The feed roller passes the jute from the feed cloth into the card at a definite rate, its back pointing pins, in conjunction with the shell, governing the rate of feed and preventing the material from being bolted. The pins of the fast-running cylinder, as the jute is fed in, split up and comb out the ribbons of fibre most vigorously so that they are fleeced out and carried steadily away on the pins of the cylinder.

The back-pointing pins of the slow moving worker catch up the more loosely held fibres from the cylinder and comb out or card the rest as they are carried swiftly past by the cylinder. The resultant tow, or *fleece*, consisting of the loose fibres thus retained and the shorter fibres from the carding, passes round with the movement of the worker, being carded to a certain extent by the pins of the cylinder during the time the cylinder is within reach of it.

The fleece on the worker is removed by the pins of the faster running stripper, and is at the same time thinned proportionally to the ratio of the speeds of the two rollers. The stripper is, in turn, cleaned by the pins of the still faster running cylinder, the fleece being again much attenuated, so much so that the cylinder practically takes the fleece away from the stripper by individual fibres, which merge with the bulk on the cylinder.

An action, similar to that which takes place at the first worker, is taking place *simultaneously* at the second worker and also at the doffer, except that, in the case of the doffer, the fleece is stripped off by the drawing rollers and passed out of the card. The fleece, as it emerges, is broad and thin, but is condensed into a

narrow ribbon as it passes down the V-shaped conductor and consolidated by the heavy top delivery roller in front.

Card Pinning

The pins on the cylinder and rollers of a card are usually fixed in conveniently sized strips of wood, 24 or 36 in. long and from 2 to 3 in. broad. These *staves*, as they are called, are hollowed out on the inside to fit the circumference of the roller and rounded on the outside to be concentric with it; they are bored at the correct angle for the pins, which are then driven in from the back. Each stave is firmly fastened to the cylinder or roller by heavy screws.

The pins are arranged in rows uniformly pitched round the roller and are equally spaced in the rows, the separate pins of each successive row being arranged relatively to those corresponding to them in the next row in a diagonal fashion which enables them to act on as many parts across the width as possible. The pitch of the pins is usually given in terms of the distance apart of the rows, measured round the roller at the surface of the stave, along with the distance apart of the pins in the row. Thus a pitch of $\frac{3}{4}$ in. \times $\frac{5}{8}$ in. simply means that the rows of pins are $\frac{3}{4}$ in. apart measured round the roller, and the pins are $\frac{5}{8}$ in. apart in the rows.

This method of giving the pitch of the pins on a roller gives a very accurate idea of the appearance of the pinning, but, for the purpose of comparing the pinning of one roller with that of another, it is of little use and may be very misleading. For this purpose, then, it is necessary to turn the pitch, as measured, into the corresponding number of pins per square inch, and this is done by the following method.

Taking the pitch, $\frac{3}{4}$ in. \times $\frac{5}{8}$ in., to find the equivalent in pins per square inch.

$\frac{1}{4}$ in. pitch means that there are 4 pins (or rows) to 1 in.

$\frac{3}{4}$ in. pitch will, therefore, mean 4 pins to 3 in. or $\frac{4}{3}$ pins to 1 in.

Similarly, $\frac{5}{8}$ in. pitch will mean $\frac{8}{5}$ pins to 1 in.

Combining these two results, the pitch taken has $\frac{4}{3}$ pins per inch one way and $\frac{8}{5}$ the other, and this will be equal to

$$\frac{4}{3} \times \frac{8}{5} = \frac{32}{15} = 2.13 \text{ pins per square inch.}$$

Occasionally we find the pitch of the pins in a roller given as so many pins per inch each way. In that case, of course, it is only necessary to multiply the two numbers given together to obtain the pins per square inch. For example, in a card cylinder with the pinning 4 per inch one way and 5 per inch the other, the pins per square inch are simply $4 \times 5 = 20$.

The necessity for using the pins per square inch for the comparison of the pinning of two rollers instead of the measured pitch is evident from the following example—

Comparing the pitch, $\frac{3}{4}$ in. \times $\frac{3}{4}$ in. with the pitch, $\frac{5}{8}$ in. \times $\frac{8}{5}$ in., the difference between them appears small, but, on turning them into the corresponding number of pins per square inch, we find that

$$\text{the first is } \frac{4}{3} \times \frac{4}{3} = \frac{16}{9} = 1.77 \text{ pins per sq. in.}$$

$$\text{and the second, } \frac{8}{5} \times \frac{8}{5} = \frac{64}{25} = 2.56 \text{ pins per sq. in.}$$

or the second is 45 per cent more than the first—much more than might be expected from a first inspection of the figures taken.

When arranging the pinning details of a card, it may be necessary to find the equivalent pitch for a certain number of pins per square inch; this may be worked out as follows: The pitch of any pinning may be represented in thirty-seconds of an inch by $\frac{x}{32} \times \frac{y}{32}$; suppose we wish to find the pitch corresponding to 8 pins per square inch, then

$$\frac{32}{x} \times \frac{32}{y} = \frac{1024}{xy} = \text{pins per sq. in.} = 8$$

whence $xy = \frac{1024}{8} = 128$

Any two nearly equal numbers, now, which, when multiplied together will give a product of 128, will denote the required pitch in thirty-seconds of an inch. In the present case the figures 11 and 12 will be near enough for practical purposes, so that the required pitch will be $\frac{1}{2}$ in. \times $\frac{1}{2}$ in. or $\frac{1}{2}$ in. \times $\frac{3}{4}$ in.

To know the number of pins per square inch of a pinning is also useful when it is required to find the number of pins necessary to fill a stave, a roller, or a cylinder, the number of pins per square inch being simply multiplied by the number of square inches in the surface to be covered. Taking a cylinder 48 in. diameter \times 70 in. long, with pitch of pins $\frac{1}{2}$ in. \times $\frac{3}{8}$ in., it is required to find how many pins it will take to fill the covering for this. The area of the surface of the cylinder is the circumference multiplied by the length; multiplying this by the pins per square inch, we have

$$\frac{48}{1} \times \frac{3.14}{1} \times \frac{70}{1} \times \frac{2}{1} \times \frac{8}{3} = 56,269, \text{ the number of pins required.}$$

Breaker Card Gearing

It is necessary now to take up the question of the drives to the cylinder and to the different parts of the breaker card. In Fig. 22, which is a diagram of

the drive on the pulley side of the card, we have the belt *A* from the drum on the main shaft driving the pulleys, one of which is fixed to the arbor of the cylinder, while the other runs loose on it. Just behind these pulleys and also fixed to the cylinder arbor is the stripper driving pulley *SDP*, which

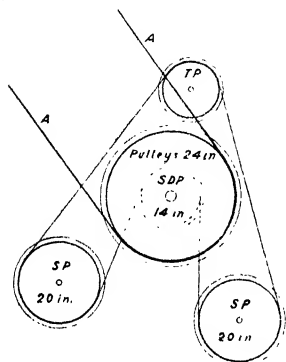

FIG. 22

drives the strippers by means of a belt passing round it and also round the two stripper pulleys *SP* fixed on the arbors of the two strippers. The other pulley *TP* round which this belt passes is merely a tension pulley serving to guide the belt and to keep it tight.

In Fig. 23 we have the toothed gearing on the other side of the machine. The cylinder pinion *CP* fixed on

the cylinder arbor drives, through three different trains of gearing, the drawing roller, the feed roller, and the workers. The revolutions of the drawing roller require to be slightly less, as a rule, than those of the cylinder; the drive, therefore, from the cylinder pinion *CP* to the wheel 52 on the end of the drawing roller is quite direct through the two intermediates I_1 and I_2 , these intermediates being necessary not only to bridge the gap between the cylinder pinion and the wheel 52 but to give the correct direction of rotation to the drawing roller. On the other end of the drawing roller from the 52 wheel is a small pinion 24, which, through a short train of gearing, drives the doffer. As already stated, the surface speed of the drawing roller must be about twice the surface speed of the doffer and, as the doffer is considerably the larger

in diameter, its revolutions must be correspondingly less. In the drive, therefore, from the drawing roller to the doffer we have the small pinion 24 on the end of the drawing roller, the double intermediate 54/28,

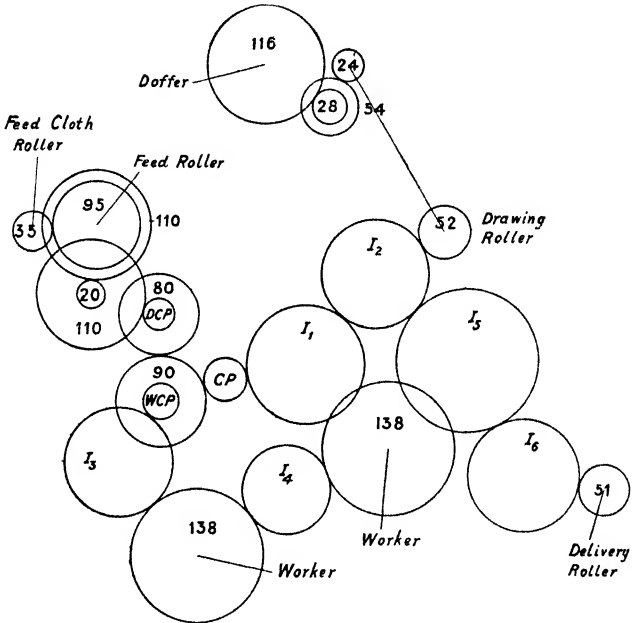

FIG. 23

and the large wheel 116 on the doffer, thus giving the necessary gearing down.

The surface speed of the feed must be approximately 1/200th of that of the cylinder; its diameter being about one-fifth, its revolutions will be 1/40th the revolutions of the cylinder, or thereabouts. To obtain this slow motion of the feed from the fast moving cylinder, we have in the train of gearing between the

cylinder and the feed roller the cylinder pinion *CP*, the single intermediate 90 which is necessary to correct the direction of rotation, the two double intermediates 80/*DCP* and 110/20, and the large wheel 110 on the feed roller. The pinion *DCP* may be changed to different sizes to suit requirements and so alter the speed of the feed proportionally. As any change in the size of this pinion will, as we shall see later, alter the ratio between the speed of the drawing roller and that of the feed, which ratio is usually called the *draft*, this pinion is called the *draft change pinion* or, simply, the *draft pinion*.

The workers, with a surface speed of three to four times the surface speed of the feed and with nearly the same diameter, will have about four times the revolutions of the feed, that is, about one-tenth of the cylinder revolutions. The gearing down for them will be less, therefore, than in the case of the feed. We have in the gearing between the cylinder and the workers the cylinder pinion *CP*, the double intermediate 90/*WCP*, the single intermediate I_3 to correct the direction of rotation, and the large wheel 138 on the worker arbor. This gives the drive to the first worker and from it, through a single intermediate I_4 , to the second worker.

There are two other subsidiary drives, one to the feed cloth roller from the feed roller, and another to the delivery roller from the drawing roller, but these, as will be seen later, are quite straightforward.

Breaker Calculations—Speeds

Taking the following details—

Speed of main shaft	225 r.p.m.
Drum driving the breaker card	20 in.
Cylinder pinion <i>CP</i>	44 teeth
Draft pinion <i>DCP</i>	24 "
Worker (change) pinion <i>WCP</i>	30 "

we shall work out the speeds that these, together with the details given in Figs. 22 and 23, will give us. From Chapter II we know that we can find the revolutions per minute of one roller driven from another by multiplying the revolutions per minute of the first shaft by all the drivers and dividing by all the driven of the gearing between them; also that, after finding the revolutions per minute of a roller, its surface speed may be got by multiplying these by the circumference in inches. It is usual, however, to give the surface speed of a roller in feet per minute, unless it is going very slowly, so that the surface speed in inches is usually divided by 12 to bring it to feet.

Commencing with the cylinder, its revolutions per minute will be

$$\begin{aligned} & \text{R.p.m. of main shaft} \times \frac{\text{Drum}}{\text{Pulley}} \\ & \frac{225}{1} \times \frac{20}{24} = 187.5 \text{ r.p.m.} \end{aligned}$$

and multiplying this by the circumference of the cylinder, 50×3.14 in., we have

$$\frac{225}{1} \times \frac{20}{24} \times \frac{50 \times 3.14}{12} = 2454 \text{ ft. per min. surface speed.}$$

The drawing roller revolutions per minute will be equal to the revolutions of the cylinder multiplied by the driver CP ($= 44$) and divided by the driven, 52, on the end of the drawing roller, the intermediates, I_1 and I_2 being ignored. We have then

$$\begin{aligned} & \frac{225}{1} \times \frac{20}{24} \times \frac{44}{52} = 158.6 \text{ r.p.m. and} \\ & \frac{225}{1} \times \frac{20}{24} \times \frac{44}{52} \times \frac{4 \times 3.14}{12} = 166 \text{ ft. per min. surface speed.} \end{aligned}$$

In this calculation it will be noticed that the figures for the drive to the cylinder from the main shaft have been taken instead of the figures 187.5 found by

calculation for the revolutions of the cylinder. By adopting this method it is often possible to cancel out figures to a greater extent and so to save time in the working out, especially if, as frequently happens, the figure for the cylinder revolutions turns out to be an awkward one.

The doffer, as we have seen, is driven from the drawing roller by the 24 on the drawing roller end, through the double intermediate 54/28 to the 116 wheel on the doffer arbor. Taking the full drive to the drawing roller instead of the calculated figures for its revolutions per minute, we have the doffer drive

$$\frac{225}{1} \times \frac{20}{24} \times \frac{44}{52} \times \frac{24}{54} \times \frac{28}{116} = 17.02 \text{ r.p.m.}$$

$$\frac{225}{1} \times \frac{20}{24} \times \frac{44}{52} \times \frac{24}{54} \times \frac{28}{116} \times \frac{19.5 \times 3.14}{12} = 86.89 \text{ ft. per min.}$$

As with the drawing roller, the revolutions per minute of the feed roller will be the revolutions per minute of the cylinder multiplied by all the drivers, $CP = 44$, $DGP = 24$, and 20, and divided by all the driven, 80, 110, and 110 in the gearing to the feed roller, the single intermediate being left out; in practice, of course, the driver and driven of each double intermediate will be taken in succession. We shall have, then,

$$\frac{225}{1} \times \frac{20}{24} \times \frac{44}{80} \times \frac{24}{110} \times \frac{20}{110} = 4.09 \text{ r.p.m.}$$

$$\frac{225}{1} \times \frac{20}{24} \times \frac{44}{80} \times \frac{24}{110} \times \frac{20}{110} \times \frac{10.75 \times 3.14}{12} = 11.5 \text{ ft. per min.}$$

and so also with the workers, the drivers in this gearing being $CP = 44$, and $WCP = 30$, and the driven 90 and 138, the intermediate I_3 being left out—

$$\frac{225}{1} \times \frac{20}{24} \times \frac{44}{90} \times \frac{30}{138} = 19.9 \text{ r.p.m.}$$

$$\frac{225}{1} \times \frac{20}{24} \times \frac{44}{90} \times \frac{30}{138} \times \frac{8.5 \times 3.14}{12} = 44.35 \text{ ft. per min.}$$

Breaker Card Calculations—Speed Ratios

Having worked out the actual speeds of the cylinder and the different rollers, it next becomes necessary to take up the question of the ratios between the speeds of certain rollers, especially with reference to the drawing roller and the doffer, and the drawing and feed rollers. It is obvious, of course, that the ratio of the speeds of any two rollers may be found, once we have worked them out, by simply dividing the one by the other. As a method, however, this is clumsy and laborious, and it is better to use the train of gearing between the two rollers to find the ratio of their speeds; the ratio, after all, is quite independent of what the actual speeds may be. In Chapter II a method of finding such a ratio was given, namely, to take one roller of the two—preferably the slower—as going at one revolution per minute; to find, from the gearing between the two, the revolutions of the other, and thence its surface speed; and then to divide this by the corresponding surface speed of the first.

Take, first, the ratio between the surface speeds of the drawing roller and the doffer; we know that the doffer is the slower of the two. Suppose, then, that the doffer is making one revolution per minute, its surface speed will be

$$(a) 19.5 \times 3.14 \text{ in. per min.}$$

and the corresponding surface speed of the drawing roller, with the gearing between them, will be

$$(b) \frac{116}{28} \times \frac{54}{24} \times \frac{4 \times 3.14}{1} \text{ in. per min.}$$

Dividing (b) by (a), we get

$$\frac{116}{28} \times \frac{54}{24} \times \frac{4 \times 3.14}{1} \times \frac{1}{19.5 \times 3.14} = 1.91$$

that is, the surface speed of the drawing roller is 1.91 times faster than the surface speed of the doffer and

will always be so, so long as the gearing remains as it is between them.

Dealing next with the ratio between the drawing roller and feed roller surface speeds in the same way, we suppose that the feed roller—evidently the slower of the two—is making one revolution per minute and is driving the drawing roller through the gearing between them. Taking the *DCP* as 24, we shall have

$$(a) 10.75 \times 3.14 = \text{surface speed of the feed roller in inches}$$

then, starting with the 110 on the feed roller as the first wheel, taking in their order the double intermediates, 20/110 and *DCP*/80, and the wheel 52 on the drawing roller end, and leaving out the single intermediates, 90, *CP*, I_1 , and I_2 , we get the corresponding surface speed of the drawing roller as

$$(b) \frac{110}{20} \times \frac{110}{24} \times \frac{80}{52} \times \frac{4 \times 3.14}{1} \text{ inches}$$

and dividing this by (a) we have

$$(c) \frac{110}{20} \times \frac{110}{24} \times \frac{80}{52} \times \frac{4 \times 3.14}{1} \times \frac{1}{10.75 \times 3.14} = 14.43$$

or, the drawing roller will have a surface speed 14.43 times greater than the surface speed of the feed roller, so long as the train of gearing between them remains as it is. This ratio between the surface speeds of feed roller and drawing roller is usually called the *draft* of the machine; putting it practically, it is simply the number of times the material comes out of the machine faster than it goes in.

It has been mentioned above that the draft pinion *DCP*, taken in (b) and (c) as 24, may be varied to suit requirements; calling it by the general term *DP*, we can restate the equation (c) as follows—

$$\frac{110}{20} \times \frac{110}{DP} \times \frac{80}{52} \times \frac{4 \times 3.14}{1} \times \frac{1}{10.75 \times 3.14} = \text{draft}$$

and this equation, worked out, becomes

$$\frac{346.3}{DP} = \text{draft}$$

whence $346.3 = DP \times \text{draft}$

and $\frac{346.3}{\text{draft}} = DP$ (draft pinion)

To put these results as a general statement, the constant for the draft gearing being found, the draft may be found by dividing the constant by the draft pinion in use; or the draft pinion, by dividing it by any required draft.

The ratio between the surface speed of the speed roller and that of the feed cloth (which will have the same speed as the feed cloth roller, by which it is driven) may be worked out to serve as an example of taking the faster of two rollers as the start for working out the speed ratio between them. A 95 wheel on the feed roller drives a 35 on the feed cloth roller; the feed roller, therefore, at one revolution per minute will drive the feed cloth roller at

$$\frac{95}{35} \times \frac{3.5 \times 3.14}{1} \text{ inches surface speed}$$

and, dividing this by the corresponding surface speed of the feed roller, 10.75×3.14 , we get

$$\frac{95}{35} \times \frac{3.5 \times 3.14}{1} \times \frac{1}{10.75 \times 3.14} = 0.884 \text{ times}$$

that is, the feed cloth goes at 0.884 times the speed of the surface of the feed roller. When the feed roller, therefore, goes 100 in., the feed cloth will only go $100 \times 0.884 = 88.4$ in., or the feed cloth will be slower than the feed roller to the extent of 11.6 per cent. It is sometimes recommended that the diameter of the feed cloth roller should be increased in this calculation by adding half the thickness of the feed

cloth to each side for the sake of accuracy. This is a quite unnecessary refinement; in any case, the extra speed obtained in the calculation from this addition to the feed cloth roller diameter is probably more than counterbalanced by the losses due to "slip" and "creep."

The ratio of the delivery roller surface speed to the drawing roller surface speed should present no difficulties. If the drawing roller makes one revolution per minute, the surface speed of the delivery roller will be

$$\frac{52}{51} \times \frac{4 \times 3.14}{1} \text{ inches}$$

and, dividing this by the corresponding drawing roller speed, we have

$$\frac{52}{51} \times \frac{4 \times 3.14}{1} \times \frac{1}{4 \times 3.14} = 1.019 \text{ times}$$

or, the delivery roller goes 1.019 times faster than the drawing roller. If, then, the drawing roller goes 100 in., the delivery roller will go 101.9 in. in the same time, equal to a lead of 1.9 per cent.

It is worth noting that in all these calculations to find speed ratios, that is, in working out drafts and leads, the calculation starts with the wheel on the first roller and finishes with the diameter or circumference of the same roller—the first and last terms of the calculation as finally set out always refer to the same thing.

Breaker Card Calculations—Clock Length

Fig. 24 is a diagram of the gearing to the *clock* from the feed roller. On the feed roller arbor is a 3-threaded screw gearing with a worm wheel of 42 teeth; this 42-toothed wheel is fixed to the same spindle as the pointer of the clock. The clock is used as an indicator;

when the pointer makes one revolution, the feed roller surface will move round a definite length and during that time a definite amount of jute is spread on the feed cloth of the card to suit the weight of sliver required.

To work out the *clock length*, that is, the length the surface of the feed roller travels while the pointer of the clock makes one revolution, we must suppose that the 42-toothed worm wheel on the pointer spindle is the driver and that it can drive the 3-threaded screw and, along with it, the feed roller. In Chapter I, page 16, it was seen that the screw in a screw and worm

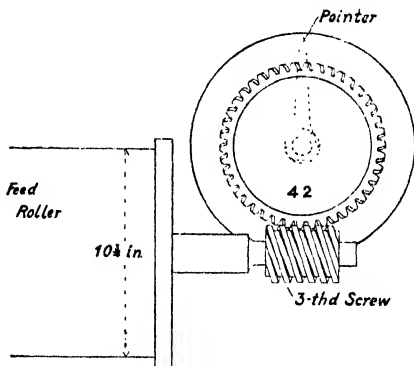

FIG. 24

wheel gearing may, for purposes of calculation, be considered as a wheel with teeth equal in number to the number of threads on the screw. For one revolution of the 42 worm wheel—and the pointer—the screw, and with it the feed roller, will make $\frac{42}{3}$ revolutions and the corresponding movement of the surface of the feed roller expressed in yards will be

$$\frac{42}{3} \times \frac{10.75 \times 3.14}{12 \times 3} = 13.13 \text{ yards:}$$

to this length the amount of jute in each dollop must be spread.

Breaker Card Calculations—Production

The amount produced by the card will depend on the rate of delivery and the weight of the sliver pro-

duced for a certain length. It is most convenient to give the weight of the sliver as so many pounds to the 100 yd. and the production is usually stated as so many hundredweight per hour. Starting with the feed and taking the weight of the dollop (the weight to be spread to one round of the clock) as 33 lb., this being spread to 13·13 yd., the weight spread to 100 yd. will be

$$\frac{33}{13\cdot13} \times \frac{100}{1} = 251\cdot3 \text{ lb.}$$

The draft on the card we have already found to be 14·24; the material comes out of the machine, therefore, 14·24 times faster than it goes in and so will be correspondingly lighter. The weight, then, of the sliver delivered will be

$$\frac{33}{13\cdot13} \times \frac{100}{1} \times \frac{1}{14\cdot24} = 17\cdot65 \text{ lb. per 100 yards.}$$

We can now work out the production. Taking the speed of the drawing roller in feet per minute, we turn it into 100 yd. lengths; then multiplying the result by 17·65 lb., the weight which each 100 yd. of sliver must be, we get the pounds delivered per minute, which may be readily turned into pounds per hour by multiplying by 60, and this again into hundredweights by dividing by 112. This may be easily followed from the working out—

$$\frac{225}{1} \times \frac{20}{24} \times \frac{44}{52} \times \frac{4 \times 3 \cdot 14}{12} \times \frac{1}{3} \times \frac{1}{100} \times \frac{17\cdot65}{1} \times \frac{1}{112} \times \frac{60}{1} = 5\cdot23 \text{ cwt.}$$

Drawing roller r.p.m.

Drawing roller ft. per min.

Drawing roller yd. per min.

Drawing roller 100 yd. per min.

Delivery in lb. per min.

Delivery in cwt. per min.

Delivery in cwt. per hour

Calculations for Lawson Breaker Card

So far, the speeds of a breaker card have been worked out with the drum and the different change pinions given; it will now be necessary to see how to work out the drum and the different change pinions required

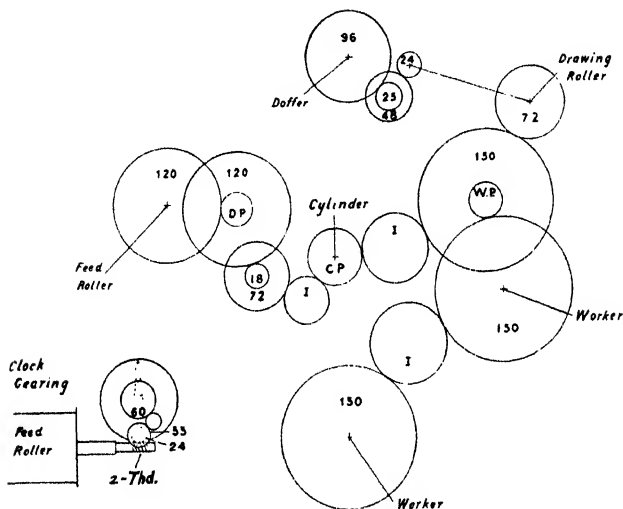

FIG. 25

for certain speeds. Suppose, then, we have to start a new Lawson breaker card with suitable speeds. The gearing of this card is slightly different from that of the Fairbairn, which has just been dealt with; the pulley side, however, is practically the same and may be represented by the diagram in Fig. 22. A diagram of the gearing on the other side is given in Fig. 25, the drive to the delivery roller being omitted. It will be noticed that the principal difference from the Fairbairn gearing is in the drive to the workers, which,

in the case of the Lawson, is taken from one of the intermediates 150 in the gearing to the drawing roller.

It will, first of all, be advisable to set out the drives to the different parts in the manner of formulae, using symbols in place of the number of teeth for the different change pinions. These formulae will be handy for reference in the actual calculations. Taking 192 revolutions per minute as the speed of the main shaft and calling the drum D , the formulae for the speeds and speed ratios in the card will be as follows—

$$\begin{aligned} \text{Cylinder:} \quad & \frac{192}{1} \times \frac{D}{24} \times \frac{50 \times 3.14}{12} \\ & = \text{ft. per min., surface speed} \end{aligned}$$

$$\begin{aligned} \text{Drawing roller:} \quad & \frac{192}{1} \times \frac{D}{24} \times \frac{CP}{72} \times \frac{4 \times 3.14}{12} \\ & = \text{ft. per min., surface speed} \end{aligned}$$

$$\begin{aligned} \text{Doffer:} \quad & \frac{192}{1} \times \frac{D}{24} \times \frac{CP}{72} \times \frac{24}{48} \times \frac{25}{96} \times \frac{15.5 \times 3.14}{12} \\ & = \text{ft. per min., surface speed} \end{aligned}$$

$$\begin{aligned} \text{Feed roller:} \quad & \frac{192}{1} \times \frac{D}{24} \times \frac{CP}{72} \times \frac{18}{120} \times \frac{DP}{120} \times \frac{10 \times 3.14}{12} \\ & = \text{ft. per min., surface speed} \end{aligned}$$

$$\begin{aligned} \text{Worker:} \quad & \frac{192}{1} \times \frac{D}{24} \times \frac{CP}{150} \times \frac{WP}{150} \times \frac{9.5 \times 3.14}{12} \\ & = \text{ft. per min., surface speed} \end{aligned}$$

$$\begin{aligned} \text{Stripper:} \quad & \frac{192}{1} \times \frac{D}{24} \times \frac{14}{20} \times \frac{13 \times 3.14}{12} \\ & = \text{ft. per min., surface speed} \end{aligned}$$

$$\begin{aligned} \frac{\text{Drawing roller}}{\text{Doffer}}: \quad & \frac{96}{25} \times \frac{48}{24} \times \frac{4}{15.5} \\ & = 1.98, \text{ ratio of D.R. speed to doffer speed} \end{aligned}$$

$$\begin{aligned} \text{Draft:} \quad & \frac{120}{DP} \times \frac{120}{18} \times \frac{72}{72} \times \frac{4}{10} = \frac{320}{DP} \\ & = \text{draft, 320 being Constant} \end{aligned}$$

$$\text{Clock length : } \frac{60}{33} \times \frac{24}{2} \times \frac{10 \times 3.14}{12 \times 3}$$

$$= 19.04 \text{ yards}$$

$$\text{Production : } \frac{192}{1} \times \frac{D}{24} \times \frac{CP}{72} \times \frac{4 \times 3.14}{12} \times \frac{1}{3} \times \frac{L}{100} \times \frac{1}{112} \times \frac{60}{1}$$

$$= \text{cwt. per hr.,}$$

L being the weight of the sliver in pounds per 100 yd.

It is required to arrange this card to deliver, say, 5 cwt. per hour of sliver weighing 17.5 lb. to the 100 yd. and we have to find the drum, draft pinion, and worker pinion for normal speeds and also the dollop weight to give the required weight of sliver. The most convenient and logical procedure is, first, to find the drum necessary to give the correct cylinder speed; secondly, the cylinder pinion to drive the drawing roller at the speed necessary to give the required production; thirdly, the draft pinion to make the feed roller go at a speed which will give a satisfactory carding action between it and the cylinder; fourthly, the worker pinion to drive the workers at a speed about three to four times that of the feed; and lastly, the fixing of the speeds of the drawing roller and feed roller, having settled the draft, to work out the dollop weight for the required weight of sliver.

The normal surface speeds for a breaker card given on page 44 are, with slight modifications, repeated here for reference—

Cylinder	. 2400 ft. per min.
Feed	. About 1/200th of cylinder speed
Workers	. 35 to 50 ft. per min.
Strippers	. 350 to 500 ft. per min.
Drawing roller	At speed to give the required production
Doffer	. Half the speed of the drawing roller

We shall take the speed of the main shaft as 192 r.p.m.
First, then, to find the drum to drive the cylinder at

2400 ft. per min., using the formula for the cylinder speed we have

$$\frac{192}{1} \times \frac{D}{24} \times \frac{50 \times 3.14}{12} = \frac{2400}{1}$$

$$D = \frac{2400 \times 24 \times 12}{192 \times 50 \times 3.14} = 23 \text{ inches drum}$$

The student is referred to Chapter II, page 34 for the method of solving this and the equations to follow.

Secondly, to find the cylinder pinion to give a production of 5 cwt. per hr. of 17.5 lb. to 100 yd. sliver. Substituting 23 for D in the production formula, we get

$$\frac{192}{1} \times \frac{23}{24} \times \frac{CP}{72} \times \frac{4 \times 3.14}{12 \times 3} \times \frac{17.5}{100} \times \frac{1}{112} \times \frac{60}{1} = \frac{5}{1}$$

$$CP = \frac{5 \times 24 \times 72 \times 12 \times 3 \times 100 \times 112}{192 \times 23 \times 4 \times 3.14 \times 17.5 \times 60}$$

$$= 59.8 \text{ (or 60) cylinder pinion.}$$

If it is preferred to make the calculation in a step by step fashion, we may:

1. Find the required production for one minute in pounds.

2. Divide this by 17.5 to give the number of 100 yards and then multiply this by 100 to give the yards delivered per minute.

3. Reduce the yards to inches and divide by the circumference of the drawing roller in inches, which will give the D roller revolutions per minute.

4. Find the cylinder pinion to give these drawing roller revolutions per minute.

This working out will be as follows—

1. Required production per minute in pounds,

$$\frac{5}{1} \times \frac{112}{60} = \frac{28}{3} \text{ lb. per min.}$$

2. Turning this into corresponding yards.

$$\frac{28}{3} \div \frac{17.5}{1} \times \frac{100}{1} = \frac{28}{3} \times \frac{1}{17.5} \times \frac{100}{1} = \frac{160}{3} \text{ yd. per min.}$$

3. Equivalent in drawing roller revolutions per minute,

$$\begin{aligned} \frac{160}{3} \times \frac{3}{1} \times \frac{12}{1} \div \frac{4 \times 3 \cdot 14}{1} &= \frac{160}{3} \times \frac{3}{1} \times \frac{12}{1} \times \frac{1}{4 \times 3 \cdot 14} \\ &= \frac{480}{3 \cdot 14} \text{ r.p.m. of drawing roller.} \end{aligned}$$

4. Find cylinder pinion to give these drawing roller revolutions per minute,

$$\begin{aligned} \frac{192}{1} \times \frac{23}{24} \times \frac{CP}{72} &= \frac{480}{3 \cdot 14} \\ CP &= \frac{480 \times 24 \times 72}{192 \times 23 \times 3 \cdot 14} \\ &= 60 \text{ cylinder pinion.} \end{aligned}$$

In this way of working it is very necessary to designate clearly the nature of the result obtained after each step, such as yards per minute, revolutions per minute, etc.; much confusion is saved thereby. This way takes a much longer time to work out than the other and does not give quite the same opportunities for cancelling out; the student is, therefore, strongly advised to practise the first method of setting out the whole of the operations to be performed in the calculation in one line whenever possible. A minor point to be noted when calculating in the step by step fashion, is not to turn such numbers as $\frac{2 \cdot 8}{3}$, $\frac{1 \cdot 6 \cdot 0}{8}$, etc., into decimals, such as 9.33, 53.3, etc., as, evidently, they are much more troublesome to deal with and less likely to be cancelled out than the original fractions. The example worked out shows this very clearly.

Thirdly, to find the draft pinion to make the feed roller go at $\frac{1}{200}$ th of the cylinder speed. The cylinder speed being 2400 ft. per min., the feed roller must go at

$$\frac{2400}{200} = 12 \text{ ft. per min. ;}$$

then from formula for speed of feed roller

$$\frac{192}{1} \times \frac{23}{24} \times \frac{60}{72} \times \frac{18}{120} \times \frac{DP}{120} \times \frac{10 \times 3.14}{12} = \frac{12}{1}$$

$$DP = \frac{12 \times 24 \times 72 \times 120 \times 120 \times 12}{192 \times 23 \times 60 \times 18 \times 10 \times 3.14}$$

= 24 draft pinion

Fourthly, to find the worker pinion to make the worker go at, say, 42 ft. per min.; substituting in the formula for worker speed, we have

$$\frac{192}{1} \times \frac{23}{24} \times \frac{60}{150} \times \frac{WP}{150} \times \frac{9.5 \times 3.14}{12} = \frac{42}{1}$$

$$WP = \frac{42 \times 24 \times 150 \times 150 \times 12}{192 \times 23 \times 60 \times 9.5 \times 3.14}$$

= 34.3, say 35 worker pinion.

Lastly, to find the dollop weight to give a sliver of 17.5 lb. per 100 yd. delivered; writing the calculation as a formula, we have

$$17.5 \times \text{draft} \div 100 \times \text{clock length} = \text{dollop weight}$$

Sliver per 100 yd.

Weight on feed per 100 yd.

Weight on feed per yard.....

Weight on feed for clock length

$$\text{The draft on the card} = \frac{\text{constant}}{DP} = \frac{320}{24} = \frac{40}{3}$$

Substituting for the draft and the clock length in the above formula

$$\frac{17.5}{1} \times \frac{40}{3} \times \frac{1}{100} \times \frac{19}{1} = 44.33 \text{ lb. dollop weight.}$$

The speed of the strippers as given by particulars from diagram, Fig. 22, and main shaft speed of 192 r.p.m. is

$$\frac{192}{1} \times \frac{23}{24} \times \frac{14}{20} \times \frac{13 \times 3.14}{12} = 438 \text{ ft. per min. surface speed}$$

and this is within the practical limits. Should a lower speed be preferred, it may be obtained by changing the stripper driving pulley of 14 in. for one proportionally smaller. If, for example, a surface speed of 360 ft. per min. were wanted, the 14 in. pulley would have to be changed for one of

$$14 \times \frac{360}{438} = 11.5 \text{ in.}$$

The ratio between the drawing roller and doffer surface speeds has already been checked and shown to be 1.98, which is quite in order. It may, however, be advisable to show how a pinion to give the correct ratio may be obtained. In the doffer gearing given in Fig. 25, for example; taking the 24 on the end of the drawing roller as the change pinion, to find the size this should be to make the drawing roller speed twice that of the doffer, we should have

$$\frac{96}{25} \times \frac{48}{\text{change pinion}} \times \frac{4}{15.5} = \frac{2}{1}$$

$$\text{Change pinion} = \frac{96 \times 48 \times 4}{2 \times 25 \times 15.5} = 23.8 \text{ (24)}$$

The pinions as calculated having been fitted on, the card should be ready for working and should give the production required with reasonably good results on the material. A certain percentage has to be added to the theoretical speed of the drawing roller to allow for losses from stoppages, belt slipping, etc., but this will be dealt with later. After the card has been started, adjustments may have to be made of the feed roller and worker speeds if the sliver, on examination, is found to be not quite what is required; but this, of course, is a matter of experience and skill, not of calculation.

It should be noted that no definite draft was arranged for; the drawing roller was set to go at the speed

necessary for the required production, and the feed roller at a speed relative to that of the cylinder which, it is known from experience, gives satisfactory results: and this arrangement of speeds determined the draft. It is really of more importance to have a suitable speed

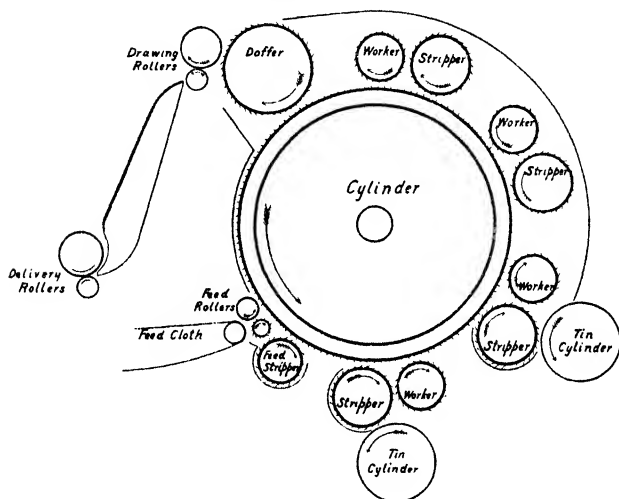

FIG. 26

of feed roller than a particular draft; with very little trouble, however, details may be so arranged that the draft is within practical limits. If we make the weight in pounds per 100 yd. of the sliver delivered about $\frac{1}{8}$ th to $\frac{1}{2}$ nd of the pounds to be delivered per hour, we can ensure this.

The Finisher Card

The finisher card may be either half-circular or full-circular. In the half-circular the feed is on the one side and the delivery on the other, so that the whole

arrangement, including the gearing, is very similar to that of the breaker card. The calculations, therefore, with regard to it need not be considered here.

In the full-circular finisher, on the other hand, the arrangement of the machine is quite different. In Fig.

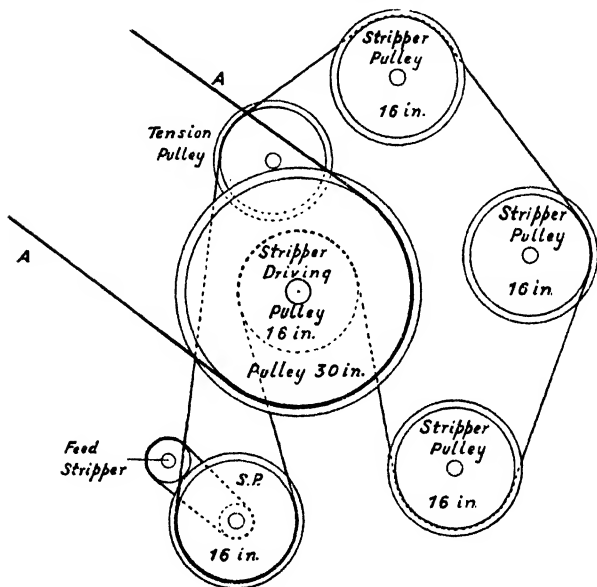

FIG. 27

26 we have an outline section of the machine, showing the arrangement of the cylinder and the different rollers. The feed rollers and the drawing roller, it will be seen, are on the same side of the machine, with the pairs of workers and strippers filling the space round the machine, thus giving the name to the type.

There is no difference in principle between the actions of the breaker and finisher cards, though there are

naturally some differences in the details of the machines due to the different state in which the material is supplied to each. The feed rollers, for instance, are different; the first pair of rollers in the finisher is placed quite near the feed rollers, and so on; these differences, however, do not concern us so much at present as the different arrangement of the gearing to suit the disposition of the rollers in the card.

Finisher Card Gearing

In Fig. 27 we have the drive on the pulley side of a full-circular finisher card. The belt from the drum on the main shaft drives the 30 in. pulleys on the cylinder arbor, and the stripper driving pulley fixed on the same arbor behind the pulleys drives the stripper pulleys in the same way as in the breaker. The feed stripper is driven from the first stripper by means of sprocket wheels connected by a chain.

Fig. 28 is a diagram of the gearing on the other side of the machine. The cylinder pinion on the cylinder arbor is, as before, the main driver, and there are again the three principal drives—to the drawing roller, to the feed roller, and to the workers. The drive to the drawing roller from the cylinder pinion is straight through the single intermediates, I_1 , I_2 , and I_3 , to the 60 on the end of the drawing roller, the *three* intermediates being necessary to give the correct rotation. At the further end of the drawing roller is a 22 wheel which, through the double intermediate $54/28$ and the intermediate I_4 (to give correct rotation) drives the wheel 88 on the doffer end. Continuing, from the near end of the doffer we have the drive to the workers by means of the 80 wheel on the doffer end, the double intermediate $64/WP$, and the 88 wheel on the end of the fourth worker; from this worker the drive is conveyed round the card to the other workers, one

after another, by the intermediates I_5 , I_6 , and I_7 . Finally, we have the drive to the feed roller from the cylinder pinion through the three intermediates I_1 , I_2 , and I_3 , the double intermediates 72/48 and 116/DP, to the 118 wheel on the end of the feed roller.

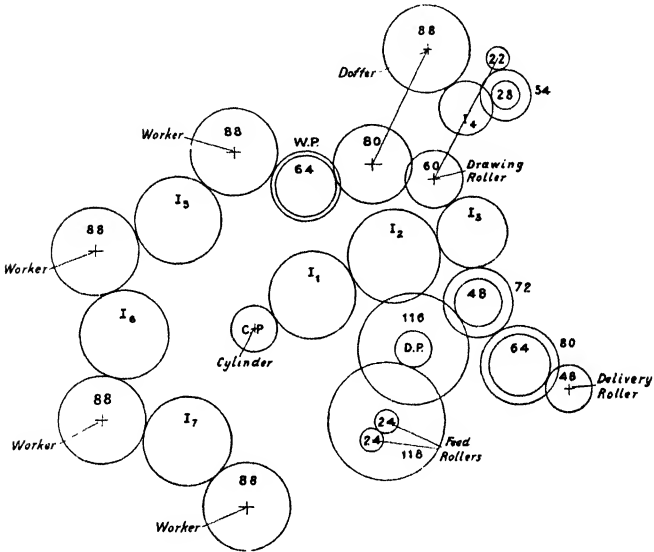

FIG. 28

The speeds for the different parts of the finisher card are very similar to those for the breaker card, the surface speeds commonly in use being

Cylinder	. 2400 to 2800 ft. per min.
Feed roller	. $1/180$ th to $1/250$ th of cylinder speed.
Workers	. About 30 ft. per min.
Strippers	. 300 to 500 ft. per min.
Draft .	. From 10 to 18.
Doffer	. About half of the drawing roller speed.

The variations in the surface speeds used are largely

due to the differences in quality and strength of the material; but the speed of the feed may vary with the proportion of breakers to finishers, which varies from one breaker to two finishers to two breakers to three finishers—the first case naturally requiring a slower and heavier feed than the second. The figures given for the strippers represent the highest and lowest speeds used in practice, the higher speeds being used when it is necessary to throw out dirt and sticks present in the material; with good clean jute it is, on the whole, better to have the stripper speed on the low side rather than the high. The draft will vary in accordance with the proportion of breakers to finishers, the weight of sliver produced, and the required production.

Finisher Card Calculations

It will be advisable, first of all, to write down the formula for the surface speeds of the different parts and also for the speed ratios, taking 192 revolutions per minute as the speed of the main shaft, D as the drum, and using the symbols for the change pinions.

$$\text{Cylinder:} \quad \frac{192}{1} \times \frac{D}{30} \times \frac{50 \times 3.14}{12} \text{ ft. per min.}$$

$$\begin{aligned} \text{Feed roller:} \quad & \frac{192}{1} \times \frac{D}{30} \times \frac{CP}{72} \times \frac{48}{116} \times \frac{DP}{118} \\ & \times \frac{4 \times 3.14}{12} \text{ ft. per min.} \end{aligned}$$

$$\text{Drawing roller:} \quad \frac{192}{1} \times \frac{D}{30} \times \frac{CP}{60} \times \frac{4 \times 3.14}{12} \text{ ft. per min.}$$

$$\begin{aligned} \text{Doffer:} \quad & \frac{192}{1} \times \frac{D}{30} \times \frac{CP}{60} \times \frac{22}{54} \times \frac{28}{88} \\ & \times \frac{16.5 \times 3.14}{12} \text{ ft. per min.} \end{aligned}$$

$$\text{Worker: } \frac{192}{1} \times \frac{D}{30} \times \frac{CP}{60} \times \frac{22}{54} \times \frac{28}{88} \times \frac{80}{64} \times \frac{WP}{88} \\ \times \frac{9.5 \times 3.14}{12} \text{ ft. per min.}$$

$$\text{Strippers: } \frac{192}{1} \times \frac{D}{30} \times \frac{16}{16} \times \frac{11.25 \times 3.14}{12} \text{ ft. per min.}$$

$$\frac{\text{Drawing roller}}{\text{Doffer}}: \frac{88}{28} \times \frac{54}{22} \times \frac{4 \times 3.14}{16.5 \times 3.14} = 1.87$$

$$\text{Draft: } \frac{118}{DP} \times \frac{116}{48} \times \frac{72}{60} \times \frac{4 \times 3.14}{4 \times 3.14} = \frac{342.2}{DP} \\ = \text{draft, } 342.2 \text{ being constant}$$

$$\text{Production: } \frac{192}{1} \times \frac{D}{30} \times \frac{CP}{60} \times \frac{4 \times 3.14}{12 \times 3} \times \frac{P}{100} \\ \times \frac{1}{112} \times \frac{60}{1} \text{ cwt. per hour}$$

P being the weight of the sliver delivered in pounds per 100 yards.

We shall suppose now that we have a system of which two Lawson breakers and three finisher cards such as the above form a part, the three finishers taking away the production of the two breakers. The breakers are producing 5 cwt. per hour of sliver weighing $17\frac{1}{2}$ lb. per 100 yd., and are provided with drum, change pinions, and dollop, all as arranged for in the calculations worked out on page 63. We shall have, then, to arrange that the finishers produce, each, $\frac{5 \times 2}{3} = \frac{10}{3}$ cwt. per hour and also to set them for correct speeds. We shall take

Main shaft speed as 192 r.p.m.

Cylinder surface speed to be 2500 ft. per min.

Feed roller speed to be $\frac{1}{250}$ th of cylinder speed

Worker surface speed to be 30 ft. per min.

Sliver to be 14 lb. per 100 yd. delivered.

The procedure will be very much the same as with the breaker card. The drum will first be found to give

the correct cylinder speed; then, the cylinder pinion to drive the drawing roller at the speed necessary to give the required production; next, the draft pinion to give the correct speed of feed; and, lastly, the worker pinion for the required speed of worker. We may also, for the sake of the example, find the pinion necessary to make the ratio of the drawing roller and doffer surface speeds equal to 2. After these are all settled, we must find the number of ends required on the feed cloth to give the correct weight of delivered sliver per 100 yd.

First, then, to find the drum to drive the cylinder at 2500 ft. per minute surface speed,

$$\frac{192}{1} \times \frac{D}{30} \times \frac{50 \times 3.14}{12} = \frac{2500}{1}$$

$$D = \frac{2500 \times 30 \times 12}{192 \times 50 \times 3.14} = 29.8 \text{ in. drum—take 30 in.}$$

Secondly, to find the cylinder pinion to drive the drawing roller so as to give a production of $\frac{1}{8}$ cwt. per hour of sliver weighing 14 lb. per 100 yd.,

$$\frac{192}{1} \times \frac{30}{30} \times \frac{CP}{60} \times \frac{4 \times 3.14}{12 \times 3} \times \frac{14}{100} \times \frac{1}{112} \times \frac{60}{1} = \frac{10}{3}$$

$$CP = \frac{10 \times 30 \times 60 \times 12 \times 3 \times 100 \times 112}{3 \times 192 \times 30 \times 4 \times 3.14 \times 14 \times 60}$$

= 40 cylinder pinion.

Thirdly, the draft pinion to drive the feed roller at 1/250th of the cylinder speed

$$\frac{192}{1} \times \frac{30}{30} \times \frac{40}{72} \times \frac{48}{116} \times \frac{DP}{118} \times \frac{4 \times 3.14}{12} = \frac{2500}{250}$$

$$DP = \frac{2500 \times 30 \times 72 \times 116 \times 118 \times 12}{250 \times 192 \times 30 \times 40 \times 48 \times 4 \times 3.14}$$

= 25.5 draft pinion (26)

Fourthly, the change pinion to make the drawing roller go at twice the surface speed of the doffer, taking the 28 in the doffer gearing as the change pinion, *DCP*

$$DCP \times \frac{54}{22} \times \frac{4}{16.5} = \frac{2}{1}$$

$$DCP = \frac{88 \times 54 \times 4}{2 \times 22 \times 16.5}$$

= 26 change pinion, instead of the present 28.

Fifthly, to find the worker pinion for a worker speed of 30 ft. per min.,

$$\frac{192}{1} \times \frac{30}{30} \times \frac{40}{60} \times \frac{22}{54} \times \frac{26}{88} \times \frac{80}{64} \times \frac{WP}{88} \times \frac{9.5 \times 3.14}{12} = \frac{30}{1}$$

$$WP = \frac{30 \times 30 \times 60 \times 54 \times 88 \times 64 \times 88 \times 12}{192 \times 30 \times 40 \times 22 \times 26 \times 80 \times 9.5 \times 3.14}$$

= 55 worker pinion.

Lastly, to find the number of ends required for the weight of sliver delivered to be 14 lb. per 100 yd., the breaker sliver being $17\frac{1}{2}$ lb. per 100 yd.,

$$\text{Draft on card} = \frac{\text{Constant}}{DP} = \frac{342.2}{26} = 13.16$$

$$\frac{17.5}{1} \times \frac{\text{ends on card feed}}{13.16} = \frac{14}{1}$$

$$\text{Ends required on card feed} = \frac{14 \times 13.16}{17.5} = 10.53$$

To adjust details to have a whole number for the number of ends, say 11, we make the small necessary adjustment on the draft, which will require to be longer proportionately to the heavier feed. This will mean a proportionately smaller draft pinion, or

$$26 \times \frac{10.53}{11} = 25 \text{ draft pinion required for 11 ends on the feed.}$$

The corresponding change in the speed of the feed will be too small to matter.

Finisher Card Calculations, Alternative Methods

The foregoing completes the details necessary to work the three finisher cards in conjunction with the two breaker cards; there is, however, an alternative method of working out the draft pinion to give the feed roller a surface speed having a definite ratio to that of the cylinder. In the previous calculation the pinion to give the feed roller $\frac{1}{50}$ th of the cylinder speed was worked out to give the actual speed which this meant, but it may also be worked out so as to give the ratio. For example, to find the draft pinion which will make the cylinder speed 250 times the speed of the feed, supposing that the feed roller is running at one revolution per minute and is driving the cylinder through the gearing between them, we should have

$$\frac{118}{DP} \times \frac{116}{48} \times \frac{72}{40} \times \frac{50 \times 3.14}{1} = \text{surface speed of cylinder in inches}$$

Dividing this by the corresponding surface speed of the feed roller,

$$\frac{118}{DP} \times \frac{116}{48} \times \frac{72}{40} \times \frac{50 \times 3.14}{4 \times 3.14} = \frac{\text{Surface speed of cyl.}}{\text{Surface speed of feed}} = \frac{250}{1}$$

$$DP = \frac{250 \times 48 \times 40 \times 4 \times 3.14}{118 \times 116 \times 72 \times 50 \times 3.14}$$

$$= 25.6 \text{ (26) draft pinion.}$$

The same method may be used to give any required ratio between the speeds of two rollers in the machine. If we wish, for example, to drive the workers at three times the speed of the feed rollers, taking again the feed roller as running at one revolution per minute, we should have, with the gearing connecting the feed roller with the workers,

$$\frac{118}{25} \times \frac{116}{48} \times \frac{72}{60} \times \frac{22}{54} \times \frac{26}{88} \times \frac{80}{64} \times \frac{WP}{88} \times \frac{9.5 \times 3.14}{1}$$

$$= \text{surface speed of worker}$$

Dividing this by the corresponding surface speed of the feed roller,

$$\frac{118}{25} \times \frac{116}{48} \times \frac{72}{60} \times \frac{22}{54} \times \frac{26}{88} \times \frac{80}{64} \times \frac{WP}{88} \times \frac{9.5 \times 3.14}{4 \times 3.14} = \frac{3}{1}$$

$$WP = \frac{3 \times 25 \times 48 \times 60 \times 54 \times 88 \times 64 \times 88 \times 4 \times 3.14}{118 \times 116 \times 72 \times 22 \times 26 \times 80 \times 9.5 \times 3.14}$$

$$= 54 \text{ worker pinion.}$$

In the drive to the workers the two wheels of the double intermediate between the 80 wheel on the doffer end and the 88 wheel on the worker end may both be used as change pinions. Taking the worker gearing again, but with both of these wheels as change pinions; to find what change pinions are necessary to give a worker surface speed of 30 ft. per minute, we have

$$\frac{192}{1} \times \frac{30}{30} \times \frac{40}{60} \times \frac{22}{54} \times \frac{26}{88} \times \frac{80}{WP1} \times \frac{WP2}{88} \times \frac{9.5 \times 3.14}{12} = \frac{30}{1}$$

$$\frac{WP2}{WP1} = \frac{30 \times 30 \times 60 \times 54 \times 88 \times 88 \times 12}{192 \times 30 \times 40 \times 22 \times 26 \times 80 \times 9.5 \times 3.14} = 0.86$$

which means that, with the drum and cylinder pinion in use, $WP2$ must be 0.86 times $WP1$ to give the workers a surface speed of 30 ft. per min. Taking $WP1$ as any convenient size, say 64, the corresponding size of $WP2$ will be $WC1 \times .86 = 64 \times .86 = 55$.

Dollop and Sliver Calculations

The details of the working out to give the sliver weights may be set out as follows—

$$\frac{\text{Dollop}}{\text{Clock length}} \times \frac{100}{1} \times \frac{1}{\text{breaker draft}} \times \frac{\text{ends of finisher}}{\text{finisher draft}}$$

This gives the weight per 100 yd. of the sliver off the

finisher; substituting the figures arrived at in our previous calculations, we have

$$\frac{30.3}{1} \times \frac{1}{13.13} \times \frac{100}{1} \times \frac{1}{13.33} \times \frac{11}{1} \times \frac{1}{13.68} = 13.92$$

Weight spread to clock length						
Weight spread to 1 yd.						
Weight spread to 100 yd.						
Weight of sliver per 100 yd. off breaker						
Weight of finisher feed per 100 yd.						
Weight of sliver per 100 yd. off finisher						

all these weights being in pounds.

Any one of the details necessary to give a required weight per 100 yd. off the finisher card may be worked out if the other details are known; for example, to find the dollop to give a 16 lb. per 100 yd. sliver off the finisher, the following details being given—

Clock length	12 yd.
Breaker card draft	12½.
Ends on finisher	10.
Finisher card draft	15.

Then,

$$\frac{\text{Dollop}}{12} \times \frac{100}{1} \times \frac{1}{12.5} \times \frac{10}{15} = \frac{16}{1}$$

$$\text{Dollop} = \frac{16 \times 12.5 \times 12 \times 15}{100 \times 10} = 36 \text{ lb.}$$

Again, to find the drafts on both breaker and finisher cards to give 16 lb. sliver off the finisher card, details being given as follows—

Dollop	36 lb.
Clock length	12½ yd.
Ends on finisher card	10

Then,

$$\frac{36}{12.5} \times \frac{100}{1} \times \frac{1}{\text{B. draft}} \times \frac{10}{\text{F. draft}} = \frac{16}{1}$$

$$\text{B. draft} \times \text{F. draft} = \frac{36 \times 100 \times 10}{12.5 \times 16} = 180$$

that is, any two numbers which are within the practical limits—from 8 to 14 for the breaker and 10 to 18 for the finisher—and which, when multiplied together, will give 180, may be taken as the breaker and finisher drafts to give the required weight of sliver off the finisher card with the details given. For example, taking the breaker draft as 12, the finisher draft will be $\frac{180}{12} = 15$; or with breaker draft of 10 the finisher draft will be $\frac{180}{10} = 18$.

CHAPTER V

DRAWING AND DOUBLING

Definitions and Objects

THE sliver as it comes from the finisher card is only moderately uniform, while the fibres of which it is composed are somewhat mixed up and far from straight. This sliver, therefore, requires further treatment to make it more uniform and to straighten the fibres; also, it must be reduced to a size suitable for the spinning frame. All this is done in the next process, which is called *drawing and doubling*, drawing being the uniform elongation of a sliver to make it lighter, and doubling being the running of two or more slivers together to form one. The two operations are carried out at the same time on the same machine and are complementary; the slivers pass through the machine side by side, are first drawn out to a definite extent, and are then taken in groups of an equal number in each, the slivers of each group being run into one at the front. The process is repeated once or twice on successive machines, the series of machines over which the material passes, usually two drawing frames and a roving frame, being called a *system*. In the doubling the thicks and thins of the singles tend to a certain extent to cancel one another out, and so, though these variations are marked in the singles, they become less so by comparison in the bulk, and the combined sliver is more uniform than any of its components.

This doubling or running together of single slivers would, of course, make the resultant sliver very thick, were it not counter-balanced by the drawing out of the singles as they pass over the machine. In the

system the drawing out is always much in excess of the doubling, so that the final sliver is very much lighter than that which comes from the finisher card. This lightness of the sliver is very necessary in the final process of spinning. The total amount of doublings in a system is reckoned as the *product* of the doublings on each of the different machines in the system. As many doublings as possible should be put in on the earlier machines of a system rather than the later: it is found in practice that this gives better results as regards levelness, even though the total amount of the doublings is the same.

The Drawing Frame

The drawing out is effected on a machine with two sets of rollers, the retaining rollers and, at a definite distance from them, the drawing rollers. The slivers pass from the retaining rollers to the drawing rollers and, as the drawing rollers have a greater surface speed than the retaining rollers, the sliver must be drawn out to an extent depending on the ratio of the two surface speeds to one another. The doubling is effected by taking together the slivers of each group as they emerge from between the drawing rollers and running them on the doubling plate into one sliver, which is then passed out at the front of the machine by delivery rollers, placed there for the purpose.

The different parts of a drawing frame with their names are shown in the diagram, Fig. 29. The two *retaining rollers*, back and front, along with the *jockey* or *slip roller*, constitute the feed; the retaining rollers are each in one piece and extend right across the machine, while the slip rollers are in short lengths to facilitate the threading of the sliver. The sliver, as shown in the diagram, passes under the back roller, over the jockey roller, and then under the front roller;

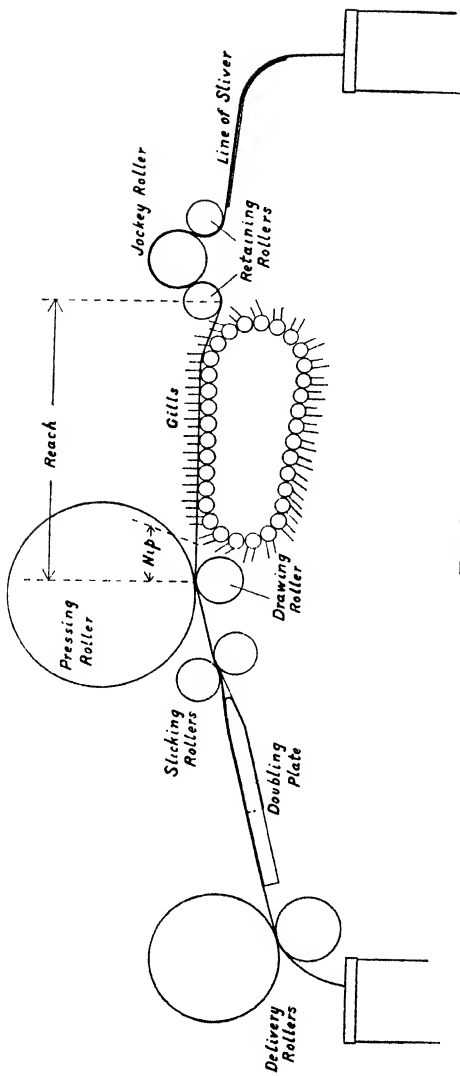

FIG. 29

this arrangement of the feed rollers with the jockey roller on top is such that any pull on the sliver will cause the jockey rollers to bear more firmly on the retaining rollers and so give them a better hold on the sliver. After passing through the feed rollers the

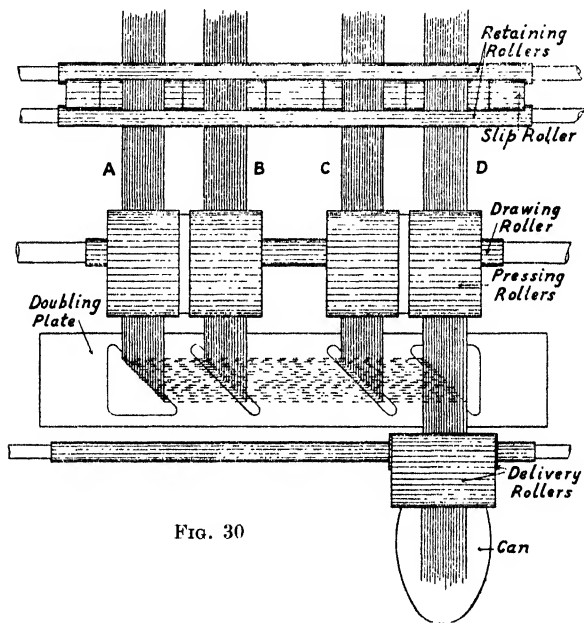

FIG. 30

sliver is carried forward by a moving lattice-work of rows of pins, called the *gills*, until it is caught by the *drawing rollers*. These consist of the drawing roller proper below with the *pressing rollers* above; the drawing roller is in one piece, stretching across the machine, the pressing rollers are narrow leather-covered bosses—usually in pairs—which are pressed against the drawing roller by a system of levers with

weights. The drawing rollers go faster than the retaining rollers, and the sliver when caught hold of by these drawing rollers is drawn out.

The slivers pass over the machine side by side as shown by *A*, *B*, *C*, and *D* in the plan given in Fig. 30. On emerging from the drawing rollers they are guided along the front of the machine by diagonal slots in the doubling plate in such a way that groups of them may be run together into one in the manner shown and finally passed out between the *delivery rollers*. The delivery rollers run practically at the same speed as the drawing rollers, and the heavy top roller serves to consolidate the combined slivers.

The *slicking rollers* immediately in front of the drawing rollers run at the same speed as the drawing rollers, and are used simply to ensure that the slivers come clean away from the drawing rollers without lapping on the leather pressing rollers.

The whole machine is mounted on a framework high enough to allow fair-sized sliver cans to be used, both at the back and the front of the machine, for holding the sliver.

Drawing Frame Details

See Fig. 29. The distance from the front retaining roller to the point of contact of the drawing rollers is called the *reach*, and should be longer than the longest fibre in the sliver. If the sliver, when passing over this space, were unsupported, it would be torn apart if drawn out to any more than a very slight extent. To prevent this and to enable the sliver to be drawn out regularly and uniformly the gills are used. These are rows of pins, or hackles, carried on bars and forming a sort of lattice, which moves in a circuit at the same rate and in the same direction as the sliver. In these the sliver is embedded so that it is supported and kept

whole while being drawn out, as only those fibres actually caught hold of by the drawing rollers are allowed to be drawn away. At the same time as these fibres are being drawn away they are pulled through the pins and are thus straightened out.

The pins of the gills enter the sliver as it leaves the feed rollers. To enable them to penetrate the sliver easily they are made to enter it as nearly perpendicularly as possible and the gills, as a whole, are made to travel slightly faster than the feed roller surface, thus putting a slight tension on that part of the sliver between the gills and the feed roller where the pins enter. The sliver, when in the gills, should be in the middle portion of the pins, neither bearing to any extent on the brass in which the pins are set or having any portion above the points of the pins. The gill pins should carry the sliver as near to the drawing rollers as possible and then drop out perpendicularly. The distance from the points of the foremost gill pins, just as they are leaving the sliver at the front end of the circuit, to the point of contact of the drawing rollers is called the *nip*, and should be as short as possible.

Drawing Frame Types

The requirements of an efficient mechanism for a drawing frame are: The gill pins must enter and leave the sliver as nearly perpendicularly as possible, the nip should be as short as possible, and the mechanism should be capable of running at a reasonably high speed. There are several types of drawing frames, all very much alike with regard to the arrangement of the main essentials. Where they differ is in the gill mechanism; the different methods of obtaining the three requirements, perpendicular entry and drop-out of the pins, short nip, and high speed of working, giving their names to the following types—

Push-bar, Open link, Ring, and Helical ;
 Spiral ;
 Circular, and Rotary.

These it is now necessary to examine in turn.

The Push-Bar Drawing Frame

In Fig. 33, which is a diagrammatic lay-out of a push-bar drawing frame, the retaining, drawing, and

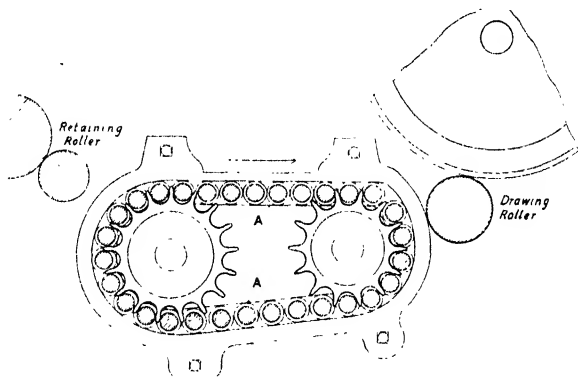

FIG. 31

delivery rollers are all shown in their relative positions with the gearing for driving them. Between the retaining and the drawing rollers are two shafts with the *carrier wheels* for driving the *faller bars* to which the gills are fixed. The method whereby these bars are driven is shown in Fig. 31; the bars move forward on a slide *A* in the direction of the arrow, being driven by the teeth of the two carrier wheels; those fallers which leave off contact with the carrier wheels are pushed forward across the gap between, both at top and bottom, by the fallers coming behind them, and so the name of "push-bar" has been given to this type

of drawing frame. The almost perpendicular entry and drop-out of the gill pins are obtained from the simple arrangement shown in Fig. 32. To one end of each faller is fixed, at right angles to the pins, a short crank carrying a pin as shown; the faller travels in the slide marked *A*, while the crank pin is always in contact with the separate slide marked *B*. The cranks of those fallers travelling along the top are kept in an

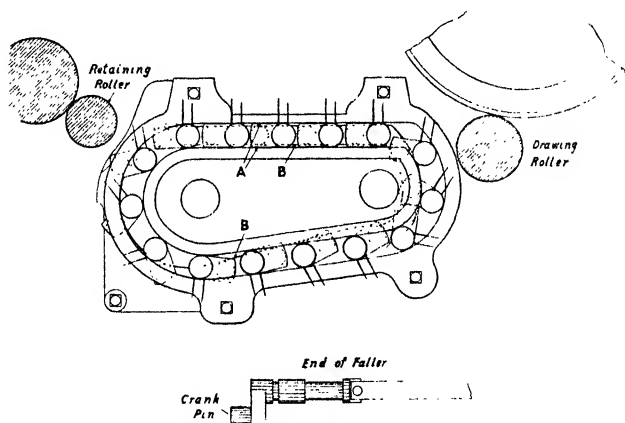

FIG. 32

horizontal position—and the gill pins, as a consequence, upright—by the relative positions of the two slides. At the drop-out the slide for the crank pin is behind that for the faller a distance equal to the distance of the crank pin from the centre line of the faller: the two, therefore, crank pin and faller, drop down at the same time, maintaining the crank in an horizontal position and the pins upright until they are clear of the sliver and past the drawing roller. The guide *B* then turns the cranks slowly round as the fallers pass along the bottom. At the back end of the circuit the

guide *B* for the crank pin is placed behind that for the faller in such a position and at such a distance that, as each faller rises, its crank pin is forced outwards until, when the pins are entering the sliver, the cranks are again horizontal and the gill pins perpendicular.

Push-Bar Gearing and Calculations

The sliver as it comes to the drawing frame has a definite weight for each 100 yd. Each sliver has to be drawn out to a definite extent and a definite number of them must be run into one; with the resulting weight of sliver per 100 yd. the drawing roller must run at the speed which will give the production required. The calculations, therefore, which will be necessary are

- Revolutions per minute and surface speed of the drawing roller;
- Ratio of drawing roller speed to retaining roller speed, i.e. draft;
- Weight of sliver delivered per 100 yards.

It is also advisable to work out the

- Ratio of the faller speed to the retaining roller surface speed;
- Number of fallers dropping out of the sliver per minute;
- Ratio of delivery roller speed to drawing roller speed; and
- Pressure of pressing rollers on drawing rollers.

The different drives in the machine are shown in the lay-out in Fig. 33 and in the diagram of the gearing given in Fig. 34. First, there is the drive from the drum on the main shaft to the driving pulleys; secondly, from the speed pinion 33 compounded with the driving pulleys to the draft pinion on the end of the drawing roller through the two intermediates 52 and I_1 ; thirdly, from the 28 on the other end of the drawing roller through the intermediate I_2 to the 37 on the end of the delivery roller; and fourthly, from the other end of the delivery roller through the intermediate I_3 to the 27 on the end of the slicking roller. Again, starting with the speed pinion 33, we have, fifthly, the drive to the carrier wheel shafts through the double intermediates

52/20 and 84/27 to the 42 on the front carrier wheel shaft and the 51 on the other—on these shafts are the

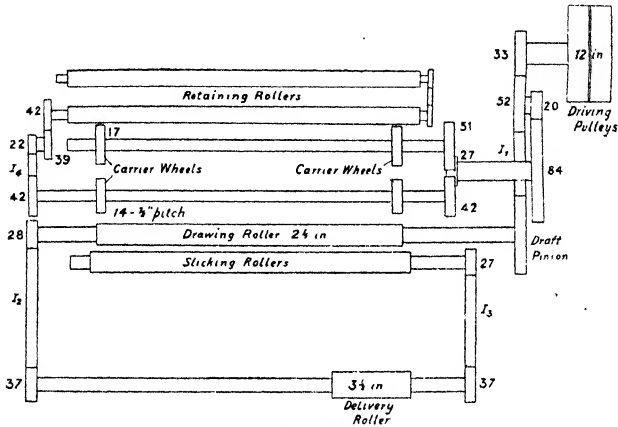

FIG. 33

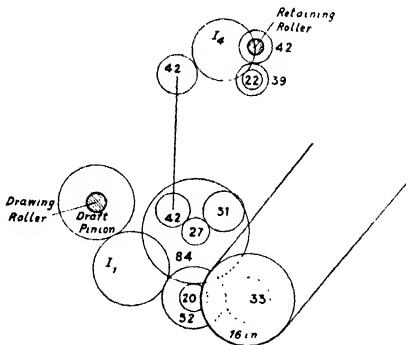

FIG. 34

carrier wheels of 14 and 17 teeth respectively, which drive the faller bars. Lastly, from the 42 on the other end of the front carrier wheel shaft we have the drive

to the 42 on the end of the retaining roller through the intermediate I_4 and the double intermediate 22/39.

Taking the speed of the main shaft as 200 r.p.m., and calling the drum D and the draft pinion DP , we may write down the formulæ for these drives as follows—

$$\text{Driving pulleys: } 200 \times \frac{D}{12} = \text{r.p.m.}$$

$$\text{Drawing roller: } \frac{200}{1} \times \frac{D}{12} \times \frac{33}{DP} \times \frac{2.5 \times 3.14}{12} = \text{surface speed}$$

$$\begin{aligned} \text{Delivery roller: } \frac{200}{1} \times \frac{D}{12} \times \frac{33}{DP} \times \frac{28}{37} \times \frac{3.5 \times 3.14}{12} \\ = \text{surface speed} \end{aligned}$$

$$\begin{aligned} \text{Slicking roller: } \frac{200}{1} \times \frac{D}{12} \times \frac{33}{DP} \times \frac{28}{37} \times \frac{37}{27} \times \frac{2\frac{3}{8} \times 3.14}{12} \\ = \text{surface speed} \end{aligned}$$

$$\begin{aligned} \text{Fallers: } \frac{200}{1} \times \frac{D}{12} \times \frac{33}{52} \times \frac{20}{84} \times \frac{27}{42} \\ = \text{r.p.m. of front carrier wheel shaft.} \end{aligned}$$

The front carrier wheel has 14 teeth of $\frac{7}{8}$ in. pitch; for each revolution of this wheel, therefore, each bar, or faller, will be driven forward 14 tooth spaces, or a distance equal to $14 \times \frac{7}{8}$ in.; or, to put it in another way, for each revolution of the front carrier wheel 14 teeth will pass a given point, each carrying a faller, or 14 fallers will be dropped carrying their gills out of the sliver. We shall have, then,

r.p.m. of front carrier wheel $\times 14 =$ fallers dropped per minute,
and this multiplied by $\frac{7}{8} =$ speed of fallers in inches per minute.

OR

$$\frac{200}{1} \times \frac{D}{12} \times \frac{33}{52} \times \frac{20}{84} \times \frac{27}{42} \times \frac{14}{1} = \text{fallers per minute}$$

$$\begin{aligned} \frac{200}{1} \times \frac{D}{12} \times \frac{33}{52} \times \frac{20}{84} \times \frac{27}{42} \times \frac{14}{1} \times \frac{7}{8} \\ = \text{speed of fallers in in. per min.} \end{aligned}$$

The back carrier wheel must, of course, have the same speed as the front. We have just seen that one revolution of the front wheel causes 14 fallers to drop out of the sliver; taking the gearing between them and supposing that the front shaft drives the back, the corresponding number of fallers dropped by the back carrier wheel will be

$$\frac{42}{51} \times \frac{17}{1} = 14 \text{ bars}$$

which is the same number as that dropped by the front.

These formulæ for the drives give the actual surface speeds: it is now necessary to find the speed ratios, drawing roller to retaining roller, i.e. the draft; fallers to retaining roller; and delivery roller to drawing roller. The working out of these is as follows—

DRAFT. Using the same method as we used for the cards, we suppose that the retaining roller is making one revolution per minute and that it is driving the drawing roller. Then the surface speed of retaining roller in inches is 2×3.14 , and the corresponding speed of the drawing roller, with the gearing between them, will be

$$\frac{42}{39} \times \frac{22}{42} \times \frac{42}{27} \times \frac{84}{20} \times \frac{52}{DP} \times \frac{2.5 \times 3.14}{1} \text{ in. per min.}$$

and dividing this by the surface speed of retaining roller, we have

$$\begin{aligned} \frac{42}{39} \times \frac{22}{42} \times \frac{42}{27} \times \frac{84}{20} \times \frac{52}{DP} \times \frac{2.5 \times 3.14}{2 \times 3.14} &= \frac{239.5}{DP} \\ &= \frac{\text{D.R. speed}}{\text{R.R. speed}} = \text{draft, } 239.5 \text{ being Constant.} \end{aligned}$$

FALLER LEAD. This is the excess in the speed of the fallers over the speed of the retaining roller, and, as it is not large, it is more conveniently expressed as a percentage on the retaining roller speed than as

a ratio. Taking the retaining roller as running at one revolution per minute with surface speed of 2×3.14 in., and that it is driving the fallers through the gearing between, the corresponding speed of the fallers will be

$$\frac{42}{39} \times \frac{22}{42} \times \frac{14}{1} \times \frac{7}{8} \text{ in. per min.}$$

Dividing this by the surface speed of the retaining roller, we get

$$\frac{42}{39} \times \frac{22}{42} \times \frac{14}{1} \times \frac{7}{8} \times \frac{1}{2 \times 3.14} = \frac{\text{Faller speed}}{\text{R.R. speed}} = 1.1$$

or the faller speed is 1.1 times the retaining roller speed. If, then, the retaining roller surface moves 100 in., the fallers will move $100 \times 1.1 = 110$ in.; that is, the fallers will go 10 in. on the 100 faster, or will have a lead of 10 per cent.

DELIVERY ROLLER. The drawing roller at one revolution per minute will drive the delivery roller at

$$\frac{28}{37} \times \frac{3.5 \times 3.14}{1} \text{ in per min. surface speed.}$$

Dividing by the corresponding speed of the drawing roller, we get

$$\frac{28}{37} \times \frac{3.5 \times 3.14}{2.5 \times 3.14} = \frac{\text{Delivery roller speed}}{\text{Drawing roller speed}} = 1.06$$

if, then, the drawing roller surface moves 100 in., the delivery roller surface will move $100 \times 1.06 = 106$ in., or a lead of 6 per cent.

Fig. 35 shows the arrangement of weight and lever for giving the necessary pressure between the pressing rollers and drawing roller. A strap *A* bearing on the axle of the pressing roller, is connected by the wire *B* and adjusting thumbscrew to the point *C* on the lever *D* which is hinged at *E*; on this lever *D* is hung the

weight W to give the pressure. This arrangement acts on the axle at one end of the pair of pressing rollers and another similar arrangement acts on the axle at the other. In the calculations with regard to this system it should be particularly noted that all the measurements referring to the lever must be made from

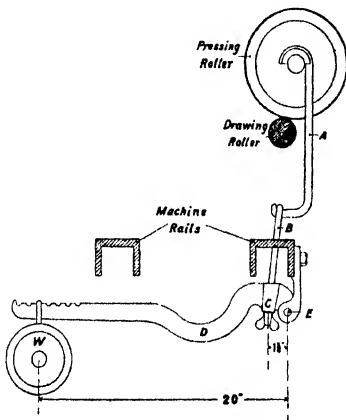

FIG. 35

the hinge E . The weight W acts by pressing the lever downwards and so causing it to pull on the wire B at the point C , and the calculation is based on the fact that the weight multiplied by its distance from the hinge must be equal to the pressure at C multiplied by the distance of C from the hinge, W and P being both expressed in terms of the same unit, usually pounds.

Calling the pressure at the point C on the lever P lb., and taking $W = 24$ lb., we have

$$P \times 1.75 = W \times 20 = 24 \times 20$$

whence $P = \frac{24 \times 20}{1.75} = 274 \text{ lb.} = \text{pressure at the point } C.$

As there is a similar arrangement at the other end of the pair of pressing rollers, the total pressure on them will be

$$\frac{24 \times 20}{1.75} \times \frac{2}{1} = 548 \text{ lb.}$$

For purposes of comparison it is usual to give the pressure as so many pounds per inch of roller face. In the present case each roller of the pair of rollers is 7 in. broad, or the two together have 14 in. of face: the pressure per inch of face, therefore, will be

$$\frac{548}{14} = 39 \text{ lb.}$$

Theoretically, the weight of the lever and the angle of the strap from the perpendicular ought to be taken into account; but, taking it generally, in all such arrangements the effect due to these factors bears approximately a constant ratio to the effect due to the weight. In practice, therefore, the weight of the lever and the angle of the strap are usually ignored and sufficient information is obtained by comparison with other results obtained on the same basis.

Let us take it now that we have a drawing frame such as we have been considering, and that it forms the first drawing of a system over which the production from one of the three cards worked out in Chapter IV has to pass. The production from a card was $3\frac{1}{2}$ cwt. per hour of 14 lb. per 100 yd. sliver; let us suppose that the doublings on the drawing frame are to be 4 into 1, the draft is to be $3\frac{1}{4}$, that the machine has two deliveries, and that we have to arrange this with a main shaft running at 200 revolutions per minute. The procedure is as follows—

The draft pinion is first found by dividing the draft constant by the required draft,

$$\frac{239.5}{3.75} = 64 \text{ draft pinion.}$$

We next find the weight of the sliver delivered in pounds per 100 yd. by multiplying the weight of the sliver from the card by the doublings on the machine and dividing by the draft ;

$$\frac{14}{1} \times \frac{4}{3.75} = 14.93 \text{ lb. per 100 yd.}$$

Then, using the production formula, we work out the drum to give the required production,

$$\frac{200}{1} \times \frac{D}{12} \times \frac{33}{64} \times \frac{2.5 \times 3.14}{12 \times 3} \times \frac{14.93}{100} \times \frac{1}{112} \times \frac{60}{1} \times \frac{2}{1} = \frac{10}{3}$$

$$\begin{aligned} \text{whence } D &= \frac{10 \times 12 \times 64 \times 12 \times 3 \times 100 \times 112}{3 \times 200 \times 33 \times 2.5 \times 3.14 \times 14.93 \times 60 \times 2} \\ &= 11 \text{ in. drum.} \end{aligned}$$

This may be worked out by a shorter method, which will be shown later, from the revolutions of the finisher card drawing roller, by using the drafts and doublings on the machine and the sizes of the drawing rollers and the number of deliveries on the card and the drawing frame.

The Open-Link Chain Drawing Frame

The open-link chain drawing frame is similar to the push-bar drawing frame in many ways, and is used for the same purpose. The principal difference is in the drive for the fallers. In the push-bar drawing the fallers, as we saw, move round in a circuit, being driven directly by two carrier wheels ; in the open-link chain drawing the fallers are carried round in a similar circuit, but on a chain which passes over two wheels and is driven by one of them. The chain is made up of links of a special type, as shown in Fig. 36 ; each link has a projection *A* in which a semicircular opening has been made and in these openings the fallers f_1, f_2 are carried. The pins b_1, b_2, \dots which join the links

together project on one side and, gearing with the teeth of the wheel, enable the chain to be driven. The method of obtaining the perpendicular entry and drop

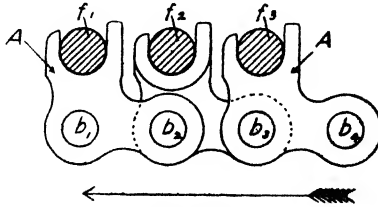

FIG. 36

out of the gill pins is the same in principle as that used in the push-bar and need not be shown here.

Fig. 37 is a lay-out showing the drives to the different parts of the machine, and Fig. 38 is a diagram of the gearing; from these the drives to the principal parts

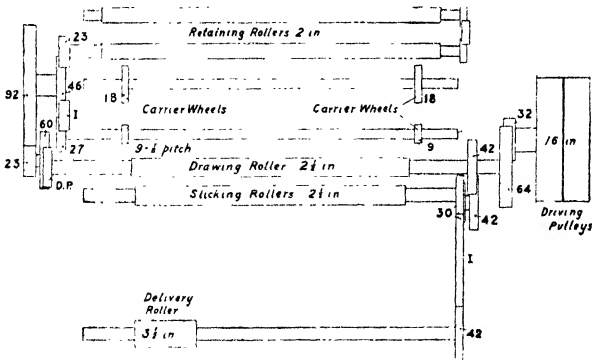

FIG. 37

may be easily followed. First, there is the drive from the drum to the 16 in. driving pulleys; secondly, from the 32 speed pinion compounded with the pulleys

to the 64 on the end of the drawing roller; thirdly, from the 42 on the drawing roller, just inside the 64, through the double intermediate 42/30 to the 30 on the end of the slicking roller and thence through the intermediate *I* to the 42 on the delivery roller. Fourthly, on the other end of the drawing roller, the draft pinion *DP* drives, through the double intermediate 60/23, the large 92; coupled with this 92 is the 46 wheel which drives on the one side the 23 on the end of the retaining roller, and on the other side, through a small intermediate, the 27 on the front carrier wheel shaft.

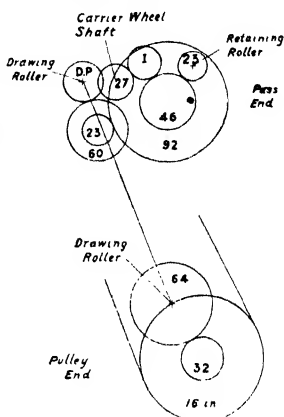

FIG. 38

Taking the speed of the main shaft as 240 revolutions per minute and calling the drum *D*, the formulæ for these drives will be

$$\text{Driving pulleys: } \frac{240}{1} \times \frac{D}{16} = \text{r.p.m.}$$

$$\begin{aligned} \text{Drawing roller: } \frac{240}{1} \times \frac{D}{16} \times \frac{32}{64} \times \frac{2.5 \times 3.14}{12} \\ = \text{surface speed in ft. per min.} \end{aligned}$$

$$\begin{aligned} \text{Slicking rollers: } \frac{240}{1} \times \frac{D}{16} \times \frac{32}{64} \times \frac{42}{42} \times \frac{30}{30} \times \frac{2.5 \times 3.14}{12} \\ = \text{surface speed.} \end{aligned}$$

$$\begin{aligned} \text{Delivery roller: } \frac{240}{1} \times \frac{D}{16} \times \frac{32}{64} \times \frac{42}{42} \times \frac{30}{42} \times \frac{3.5 \times 3.14}{12} \\ = \text{surface speed.} \end{aligned}$$

$$\begin{aligned} \text{Fallers: } \frac{240}{1} \times \frac{D}{16} \times \frac{32}{64} \times \frac{DP}{60} \times \frac{23}{92} \times \frac{46}{27} \\ = \text{r.p.m. of the front carrier-wheel shaft.} \end{aligned}$$

This shaft has on it a wheel of 9 teeth for driving the chain, each tooth of the wheel gearing with one of the pins joining the links of the chain; each tooth of the wheel, therefore, will imply a link of the chain and as each link carries a faller, the fallers passing a given point per minute will be equal to the revolutions of the front carrier-wheel shaft $\times 9$.

$$\frac{240}{1} \times \frac{D}{16} \times \frac{32}{64} \times \frac{DP}{60} \times \frac{23}{92} \times \frac{46}{27} \times \frac{9}{1} = \text{fallers per minute.}$$

DRAFT. Taking the same method as previously,

$$\frac{23}{46} \times \frac{92}{23} \times \frac{60}{DP} \times \frac{2\frac{1}{2} \times 3.14}{1} \times \frac{1}{2 \times 3.14} = \text{draft} = \frac{150}{DP}$$

Surface speed of D.R. if R.R. is at 1 r.p.m.

Surface speed of D.R.

Surface speed of R.R.

150 being constant.

FALLER LEAD. Using the same method as with the push-bar,

$$\frac{23}{27} \times \frac{9}{1} \times \frac{7}{8}$$

= speed of fallers in inches if the retaining roller is at 1 r.p.m.; dividing this by the corresponding speed of the retaining roller, 2×3.14 , we get

$$\frac{23}{27} \times \frac{9}{1} \times \frac{7}{8} \times \frac{1}{2 \times 3.14} = 1.067,$$

the number of times the faller speed is greater than that of the retaining roller. If, therefore, the retaining roller surface moves 100 in. the fallers will move 106.7 in. = 6.7 per cent lead.

DELIVERY ROLLER LEAD. In the same way, taking the drawing roller speed at 1 r.p.m.

$$\frac{\text{Delivery roller speed}}{\text{Drawing roller speed}} = \frac{42}{42} \times \frac{30}{42} \times \frac{3\frac{1}{2} \times 3.14}{2\frac{1}{2} \times 3.14} = 1$$

or the delivery roller and the drawing roller run at the same speed and there is no lead.

The Ring Drawing Frame

The ring drawing frame is very similar to the push-bar, the main difference being that in the ring drawing the bars, or fallers, are not driven by two pairs of carrier wheels inside the circuit, but by pairs of rings which drive them on the outside. Fig. 39 will show

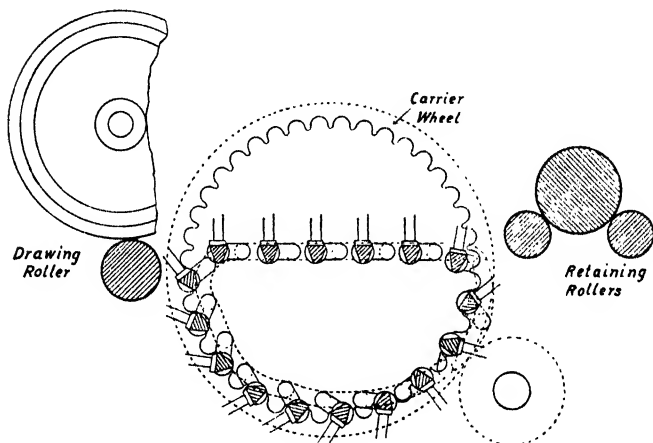

FIG. 39

the nature of the arrangement which, it will be seen, is like that of the push-bar so far as the movement of the fallers to obtain the perpendicular entry and drop out of the gill pins is concerned, and only differs in the nature of the drive to the fallers. As the gearing is practically all at one end of the machine, it is difficult to give a lay-out showing the drives, but the diagram given in Fig. 40 will serve to show the main parts of the gearing.

The principal drives in the machine are: The drive from the drum on the main shaft to the pulleys;

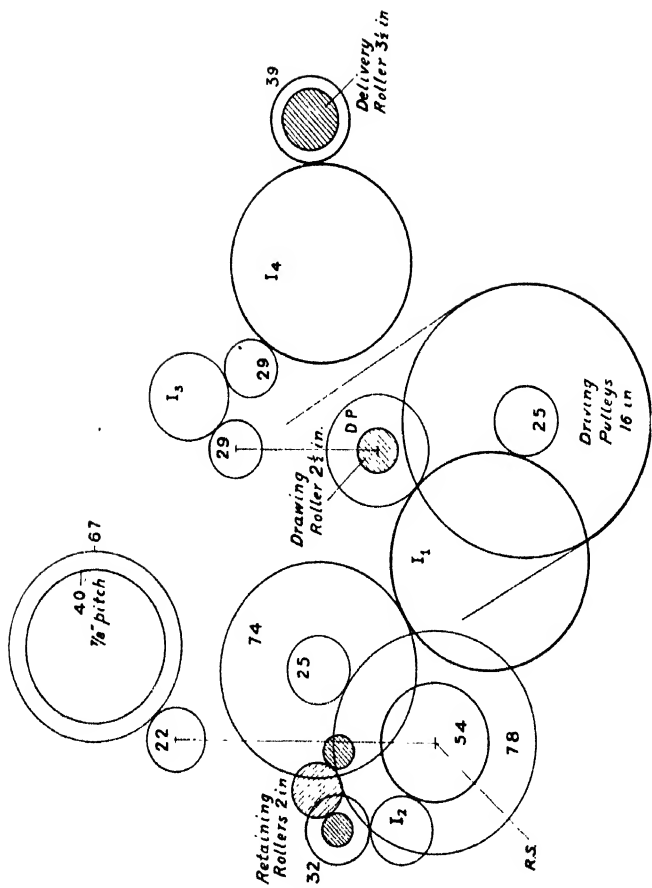

FIG. 40

from the speed pinion 25 on the pulley sleeve, through the intermediate I_1 , to the draft pinion DP on the drawing roller; from the speed pinion through the intermediate I_1 and the double intermediate $74/25$ to the 78 on the driving shaft RS for the rings which drive the fallers; and, lastly, two drives from this shaft RS , one from the 54 on the one end of it, which through the intermediate I_2 drives the 32 on the retaining roller, and another from a series of 22 pinions on it which drive the 67's on the outside of the rings, the fallers then being driven by the 40's on the inside of these rings. The drives to the delivery and slicking rollers come from a 29 on the end of the drawing roller, which through an intermediate I_3 drives the 29 on the slicking roller, the drive being further continued through the intermediate I_4 to the 39 on the delivery roller.

Taking the speed of the main shaft as 240 r.p.m. and the drum as D , the figures for the different and speed ratios are as follows—

$$\text{Driving pulleys: } \frac{240}{1} \times \frac{D}{16} = \text{r.p.m.}$$

$$\begin{aligned} \text{Drawing roller: } \frac{240}{1} \times \frac{D}{16} \times \frac{25}{DP} \times \frac{2\frac{1}{2} \times 3.14}{12} \\ = \text{surface speed in ft.} \end{aligned}$$

$$\text{Fallers: } \frac{240}{1} \times \frac{D}{16} \times \frac{25}{74} \times \frac{25}{78} \times \frac{22}{67} = \text{r.p.m. of rings.}$$

These having 40 teeth on the inside driving the fallers, we get

$$\frac{240}{1} \times \frac{D}{16} \times \frac{25}{74} \times \frac{25}{78} \times \frac{22}{67} \times \frac{40}{1} = \text{fallers per min.}$$

DRAFT.

$$\frac{32}{54} \times \frac{78}{25} \times \frac{74}{DP} \times \frac{2\frac{1}{2} \times 3.14}{2 \times 3.14} = \frac{171}{DP} = \text{draft,}$$

171 being constant.

102 JUTE SPINNING CALCULATIONS

FALLER LEAD. The internal teeth of the rings being $\frac{7}{8}$ in. pitch, we have

$$\frac{32}{54} \times \frac{22}{67} \times \frac{40}{1} \times \frac{7}{8} \times \frac{1}{2 \times 3.14} = 1.084$$

R.p.m. of ring for 1 r.p.m. of R.R.

Speed of faller for 1 r.p.m. of R.R.

Speed of faller

Speed of R.R.

or the fallers go 1.084 times faster than the retaining roller surface = 8.4 per cent lead.

DELIVERY LEAD.

$$\frac{29}{39} \times \frac{3.5}{2.5} = 1.041 \text{ times, or } 4.1 \text{ per cent lead.}$$

The Helical Drawing Frame

The Helical drawing frame differs from the Push-bar, Open-link Chain, and Ring drawings only in the method of obtaining the perpendicular entry and drop out of the gill pins from the sliver. The sketch in Fig. 40A

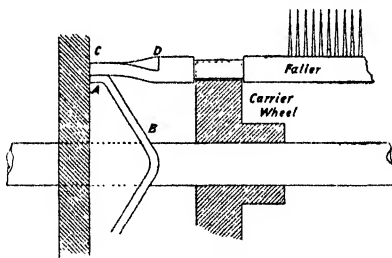

FIG. 40A

will serve to show the method used in this machine. The end of the fallers is for a short distance shaped in the form of a screw or helix as at *CD*; while the pins are imbedded in and moving along with the sliver, the horizontal portion *C* of the helix moves along a straight

slide *A*, but when the faller is dropping, the ends lides down the wedge-shaped cam *B* and, as different parts along the helix come into contact with the cam, the changing angle of the helix will keep the faller in the same position with the pins upright until they are clear of the sliver, when the return part of the cam will turn them over.

The arrangement of the gearing in this machine is somewhat similar to those of the other three, and so is not sufficiently different from them to require to be dealt with.

The Spiral Drawing Frame

In the spiral drawing frame the path of the fallers and the mechanism for operating them are entirely different from those in any of the drawing frames which have been examined.

Figs. 41 and 42 show the path of the fallers in this machine and Fig. 43 the screws, or spirals, for driving the fallers, with the cams *L* and *M* attached to them. There are two slides, *A* the top, and *B* the bottom, along which the fallers $f_1, f_2 \dots$ are driven in the direction of the arrows by means of the screws *K*, one for each slide. As each faller comes to the end of the top slide *A* the check or guide spring *D* hinged at *F* is pushed sufficiently far away from the slide *A* to allow the faller to pass down between the end of the slide *A* and the check spring *D* to the bottom slide *B*, the passage downwards being assisted by the cam on the top screw. When passing from the top slide to the bottom, the faller must leave the top screw and fall accurately into the thread of the bottom screw; this is ensured by the position and shape of the end of the top slide and the synchronizing of the screws. The bottom screw, which is of a much coarser pitch than the top screw, drives the fallers along the bottom

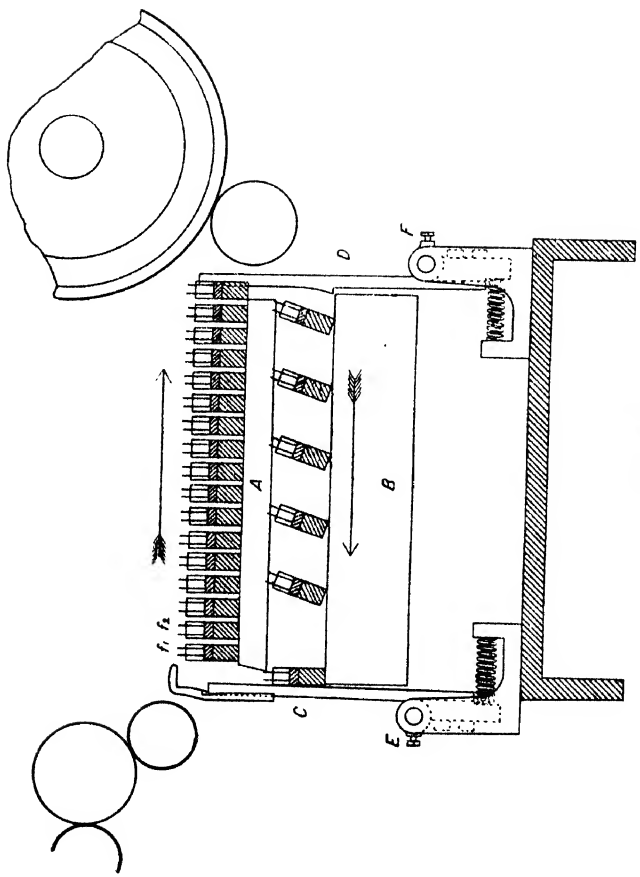

FIG. 41

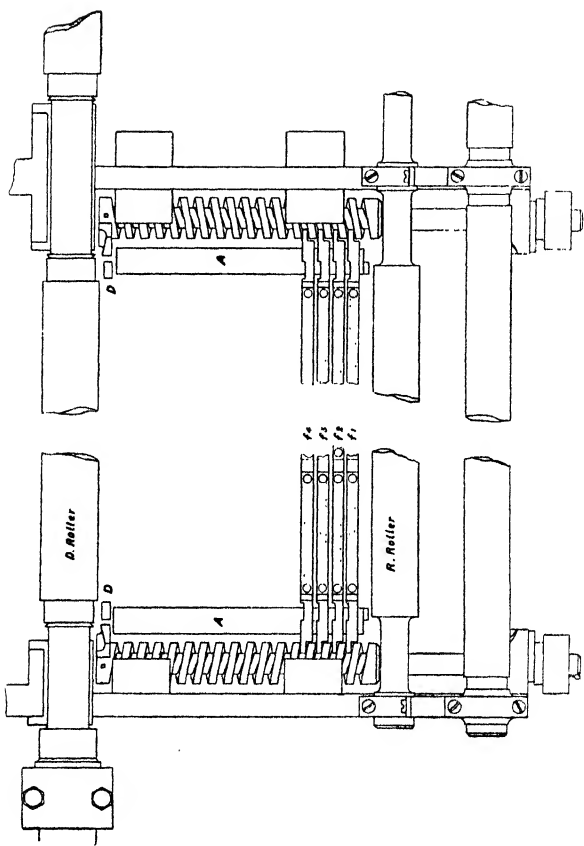

FIG. 42

slide. Again, when each faller comes to the end of the slide, the check spring *C* is forced back by the faller, which is then lifted by the cam *L* on the bottom screw and passes between the spring *C* and the end of the top slide. The shape of this end is such that, on reaching the level of the top slide, the faller will engage with the thread of the top screw, and the lifting cam is so shaped that the faller is kept on the level of the top

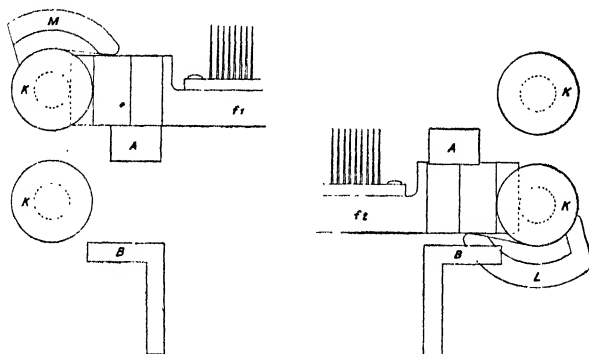

FIG. 43

slide long enough for the action of the screw to carry it right on to the slide, along which it will then travel as before. The lifting action of the cam is shown in Fig. 43.

The general arrangement of the machine is shown by the lay-out given in Fig. 44, which also shows the drives to the principal parts. In Fig. 45 a diagram of the gearing is given, but with the drives to the delivery and slicking rollers left out.

The principal drives in the machine are: First, from the drum on the shaft to the 16 in. pulleys; secondly, from the speed pinion *SP*, through the intermediate *I*₁, to the draft pinion on the end of the drawing roller:

thirdly from the 41 on the other end of the drawing roller, through the intermediate I_2 , to the 56 on the end of the delivery roller. Returning to the speed

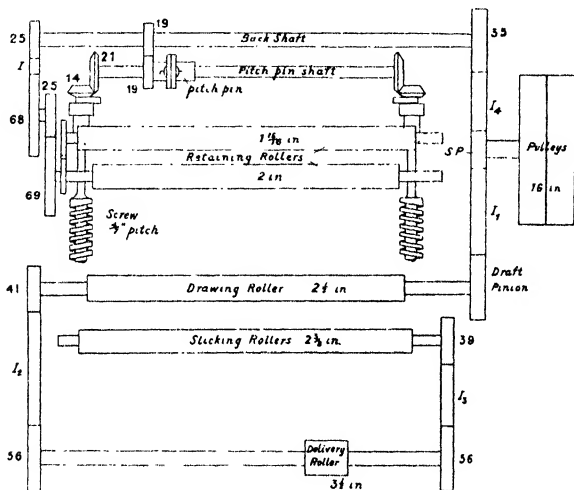

FIG. 44

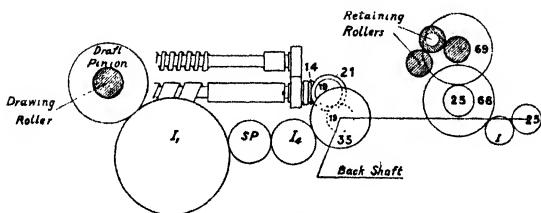

FIG. 45

pinion SP we have, fourthly, the drive from it, through the intermediate I_4 , to the 35 on the back shaft, and then, further, two drives from the back shaft; one from the pass end of it, through a small intermediate I

and the double intermediate 68/25 to the 69 on the end of the retaining roller, and the other from the 19 on the back shaft to the 19 on the *pitch pin shaft*, on which two 21's drive two 14's on the end of the screws which drive the fallers. The drive is to the bottom screw, which, in its turn, drives the top screw at the same rate as itself.

Taking the main shaft revolutions per minute as 200, and calling the drum D , the formulæ for the different drives and speed ratios are

$$\text{Drawing roller: } \frac{200}{1} \times \frac{D}{16} \times \frac{SP}{DP} \times \frac{2\frac{1}{2} \times 3.14}{12}$$

= surface speed in ft.

$$\text{Retaining roller: } \frac{200}{1} \times \frac{D}{16} \times \frac{SP}{DP} \times \frac{25}{68} \times \frac{25}{69} \times \frac{2 \times 3.14}{12}$$

= surface speed

$$\text{Faller drive: } \frac{200}{1} \times \frac{D}{16} \times \frac{SP}{35} \times \frac{19}{19} \times \frac{21}{14} = \text{r.p.m. of screws.}$$

As a faller is dropped and one raised for each revolution of the screws, the revolutions of the screws per minute give the fallers dropped per minute.

DRAFT. The retaining roller at 1 r.p.m., with the gearing between, will drive the drawing roller at

$$\frac{69}{25} \times \frac{68}{25} \times \frac{35}{DP} \times \frac{2\frac{1}{2} \times 3.14}{1} \text{ in. surface speed}$$

Dividing by the corresponding speed of retaining roller, we have

$$\frac{69}{25} \times \frac{68}{25} \times \frac{35}{DP} \times \frac{2\frac{1}{2} \times 3.14}{2 \times 3.14} = \frac{328}{DP} = \text{draft, 328 being constant.}$$

FALLER LEAD. The retaining roller at 1 r.p.m. will drive the screws at

$$\frac{69}{25} \times \frac{68}{25} \times \frac{19}{19} \times \frac{21}{14} \text{ r.p.m.}$$

The top screws are $\frac{4}{7}$ in. pitch and will drive the fallers this distance with each revolution; the speed of the fallers, therefore, will be

$$\frac{69}{25} \times \frac{68}{25} \times \frac{19}{19} \times \frac{21}{14} \times \frac{4}{7} \text{ in. per min.}$$

Dividing this by the corresponding surface speed of the retaining roller, we get

$$\frac{69}{25} \times \frac{68}{25} \times \frac{19}{19} \times \frac{21}{14} \times \frac{4}{7} \times \frac{1}{2 \times 3.14} = 1.024 \text{ times}$$

or fallers go at 1.024 times speed of retaining roller == 2.4 per cent lead.

DELIVERY ROLLER.

$$\frac{41}{56} \times \frac{3.5}{2.5} = 1.025 \text{ times}$$

or delivery roller goes at 1.025 times faster than drawing roller, or has a lead of 2.5 per cent lead.

Fig. 46 shows the arrangement of levers and weights to give the necessary pressure between the drawing and pressing rollers. It is somewhat different from the arrangement on the push-bar drawing frame. The weight is hung on the lever *A*, which is hinged at *B*; a strap *D* connects the point *C* on the lever *A* with the end of the lever *E* hinged at *G*; at the point *H* on the lever *E* an eyebolt *K* with an adjusting thumb-screw connects this lever to the strap *L*, which bears on the pressing roller axle. As noted before, all measurements referring to the levers must be made from the hinges, or fulcra, and these measurements are given in the present case on the diagram. The weight *W*, pressing down on the lever *A*, causes a downward pull at the point *C*. This pull is transferred by the strap *D* to the end of the lever *E* and causes a pull at the point *H*, this pull being transferred by the eyebolt *K* and the strap *L* to the axle of the pressing roller. As before

110 JUTE SPINNING CALCULATIONS

(page 93), the weight on the lever *A* multiplied by its distance from the fulcrum *B* is equal to the pull at the point *C* multiplied by its distance from the

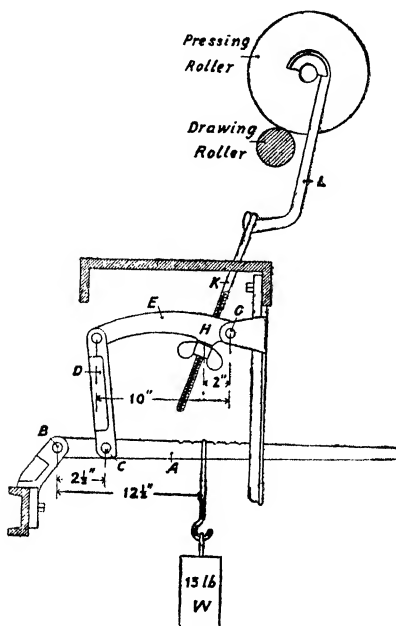

FIG. 46

fulcrum *B*. Taking the pull at the point *C* as P_1 and the measurements as given in the diagram,

$$\begin{aligned}
 P_1 \times 2\frac{1}{2} &= W \times 12\cdot5 \\
 P_1 \times 2\frac{1}{2} &= 15 \times 12\frac{1}{2} = 187\cdot5 \\
 P_1 &= \frac{187\cdot5}{2\cdot5} = 75 \text{ lb.}
 \end{aligned}$$

and this pull is transferred by the strap *D* to the end

of the lever E . Similarly, with regard to this lever E , we have, taking the pull at the point H as P_2 ,

$$P_2 \times 2 = P_1 \times 10$$

$$P_2 \times 2 = 75 \times 10 = 750$$

$$P_2 = \frac{75 \times 10}{2} = 375 \text{ lb.}$$

and this is communicated to the axle of the pressing roller. There is only one set of levers and weight to each pair of pressing rollers, and, as each roller has a face 4 in. broad, we have the pressure per inch of roller face

$$\frac{375}{4 \times 2} = 47 \text{ lb.}$$

The calculation for the pull on the axle of the pressing roller may, of course, be made in one operation thus—

$$\frac{15}{1} \times \frac{12.5}{2.5} \times \frac{10}{2} = 375 \text{ lb.}$$

Pull at point C on lever A

Pull at point H on lever E

As before, the weights of the levers and the angle of the strap are ignored.

The spiral drawing is very frequently used as the second drawing in a system; let us suppose, then, that a drawing frame such as we have been discussing is to be used as the second drawing in the system mentioned on page 94, of which the push-bar drawing is the first, and that the production of the push-bar is to pass over the spiral. The production from the push-bar was $3\frac{1}{3}$ cwt. per hour of sliver weighing 14.93 lb. per 100 yd. We shall assume that the doublings on the spiral drawing are to be 2 into 1, the draft is to be $7\frac{1}{2}$, that the machine has two heads of three deliveries each, and that it is to be driven from the same shaft running at 200 revolutions per minute, which drove

112 JUTE SPINNING CALCULATIONS

the push-bar. To find the necessary details to give the required production from these particulars we proceed as follows—

First, the draft pinion is found from the draft constant,

$$\frac{328}{7.5} = 43.7, \text{ say a 44 draft pinion}$$

next, we require the weight per 100 yd. of the sliver which will be delivered,

$$\frac{14.93}{1} \times \frac{2}{7.5} = 4 \text{ lb. per 100 yd.}$$

From this we can find the drum and speed pinion to give the required production

$$\frac{200}{1} \times \frac{D}{16} \times \frac{SP}{44} \times \frac{2.5 \times 3.14}{12} \times \frac{1}{3} \times \frac{4}{100} \times \frac{60}{1} \times \frac{6}{1} \times \frac{1}{112} = \frac{10}{3}$$

Speed of Drawing roller in in.

Speed of Drawing roller in yd.

Pounds delivered per delivery per minute.....

Pounds delivered per delivery per hour.....

Total pounds delivered per hour.....

Total hundredweights delivered per hour.....

$$\text{whence } D \times SP = \frac{10 \times 16 \times 44 \times 12 \times 3 \times 100 \times 112}{200 \times 2.5 \times 3.14 \times 4 \times 60 \times 6 \times 3} = 418$$

that is, any two convenient numbers which, when multiplied together, give 418 will be the sizes for the drum and the speed pinion, say 20 in. drum and 21 speed pinion, or 16 in. drum and 26 speed pinion.

The Rotary Drawing Frame

Fig. 47 gives a diagrammatic section through a rotary drawing, from which it will be seen that it is of a very much simpler type than any of the others we have examined. The gill pins are carried on what

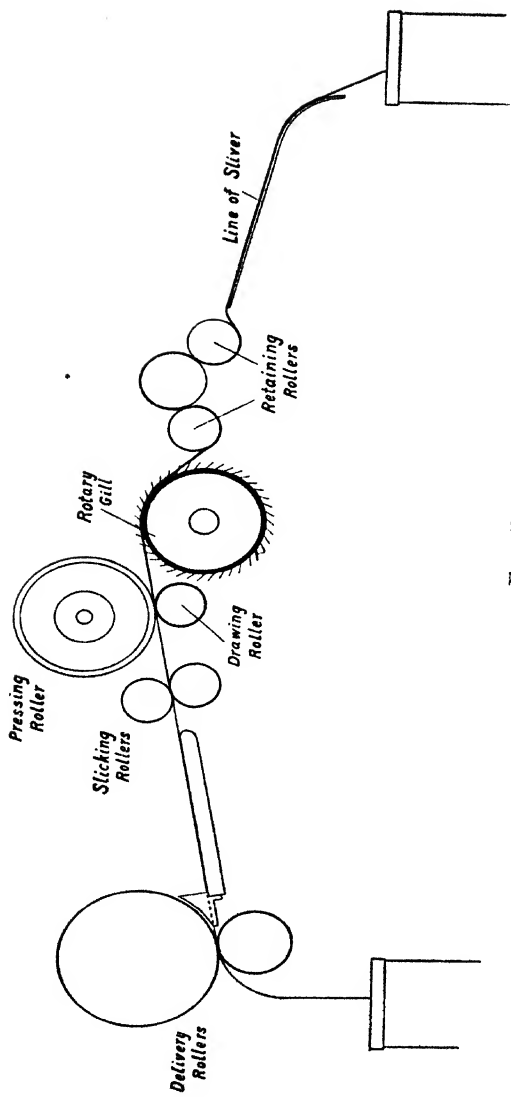

FIG. 47

is, in effect, a small barrel rotating at a rate which gives the gill pins practically the same speed as the retaining rollers. The pins are made short so as to minimize the difficulty of entry into the sliver and are placed at an angle of 45° , which, as will be seen from the drawing, makes their withdrawal from the sliver

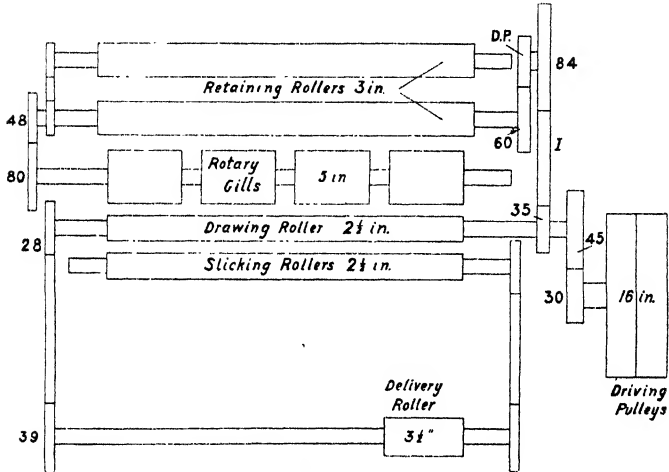

FIG. 48

nearly perpendicular and so prevents the sliver from being carried round with them. The retaining rollers are set low so that as much of the surface of the gills is used as is possible. The machine is quite effective so long as a light sliver and a short draft are used, and, as the mechanism is simple and the wearing parts few, it can be run at a high speed.

In Fig. 48 a lay-out of the gearing and of the principal parts of a rotary drawing is given, from which the drives in the machine may easily be followed. The 30 speed pinion on the sleeve of the 16 in. pulley

drives the 45 on the end of the drawing roller, and the 28 on the other end of the drawing roller drives the 39 on the delivery roller. Next, the 35 on the right hand end of the drawing roller drives, through the single intermediate *I* and the double intermediate 84/*DP*, the 60 on the retaining roller, while the 48 on the other end of the retaining roller drives the 80 on the 5 in. rotary gill.

Taking the speed of the main shaft as 200 r.p.m., the drum as *D*, and the draft pinion as *DP*, the formulæ for the different drives and speed ratios will be as follows—

$$\text{Drawing roller: } \frac{200}{1} \times \frac{D}{16} \times \frac{30}{45} \times \frac{2.5 \times 3.14}{12}$$

= surface speed in in.

$$\text{Retaining roller: } \frac{200}{1} \times \frac{D}{16} \times \frac{30}{45} \times \frac{35}{84} \times \frac{DP}{60} \times \frac{3 \times 3.14}{12}$$

= surface speed.

$$\text{Draft: } \frac{60}{DP} \times \frac{84}{35} \times \frac{2.5 \times 3.14}{3 \times 3.14} = \frac{120}{DP} = \text{draft,}$$

120 being constant

GILL LEAD. The retaining roller at 1 r.p.m. would drive the gill at

$$\frac{48}{80} \times \frac{5 \times 3.14}{1} \text{ in. surface speed.}$$

Dividing by corresponding retaining roller speed

$$\frac{48}{80} \times \frac{5 \times 3.14}{3 \times 3.14} = 1$$

or the two surface speeds are the same and there is no lead.

DELIVERY LEAD.

$$\frac{28}{39} \times \frac{3.5 \times 3.14}{2.5 \times 3.14} = \frac{98}{97.5} = 1.003, \text{ or } 0.3 \text{ per cent lead.}$$

Miscellaneous Problems

The draft on a drawing frame may easily be obtained when the surface speeds of the drawing and retaining rollers are known by simply dividing the surface speed of the drawing roller by that of the retaining roller. The faller lead may be obtained in a similar way if the surface speed of the retaining roller and the revolutions per minute and the pitch of the screw are known. For example, to find faller lead when

Retaining roller, 2 in. diameter is running at 18.75 r.p.m., and

Screws, $\frac{1}{2}$ in. pitch, are running at 240 r.p.m.,
then

$$\frac{\text{Faller speed}}{\text{Retaining roller speed}} = \frac{240 \times .5}{18.75 \times 2 \times 3.14} = \frac{120}{117.75} = 1.019$$

or the fallers go at a speed which is 1.019 times the surface speed of the retaining roller, which, as we have previously seen, is equal to a lead of 1.9 per cent.

If sufficient details be given, different factors may be found by writing down the appropriate equations and then solving them. This may be shown in the following examples—

1. Draft roller, $2\frac{1}{2}$ in. diameter running at 120 r.p.m.

Draft on machine, 8;

Faller speed, 240 fallers per min.;

Faller lead, 2 per cent.

It is required to find the pitch of screw.

$$\begin{aligned} \text{Faller speed} &= 240 \times \text{pitch of screw} \\ \text{Retaining roller speed} &= \frac{\text{Drawing roller speed}}{\text{draft}} \\ &= \frac{120 \times 2\frac{1}{2} \times 3.14}{8} = \frac{15 \times 2\frac{1}{2} \times 3.14}{1} \\ \frac{\text{Faller speed}}{\text{Retaining roller speed}} &= \frac{240 \times \text{pitch of screw}}{15 \times 2\frac{1}{2} \times 3.14} = \frac{102}{100} \\ \text{Pitch of screw} &= \frac{102 \times 15 \times 2\frac{1}{2} \times 3.14}{240 \times 100} = 0.5 \text{ in.} \end{aligned}$$

2. In Fig. 31, taking the 28 on the left end of the drawing roller as the change pinion for the delivery roller drive, it is required to find what pinion will give a delivery lead of $2\frac{1}{2}$ per cent.

Ratio of delivery roller speed to drawing roller speed

$$= \frac{CP}{37} \times \frac{3.5 \times 3.14}{2.5 \times 3.14}$$

As this is to be equal to $\frac{102.5}{100}$

$$\frac{CP}{37} \times \frac{3.5 \times 3.14}{2.5 \times 3.14} = \frac{102.5}{100}$$

$$CP = \frac{102.5 \times 37 \times 2.5 \times 3.14}{100 \times 3.5 \times 3.14} = 27.$$

3. From diagram Fig. 31 it is required to find the pulley speed if the faller speed is to be 375 fallers per minute.

$$\text{Pulley speed} \times \frac{33}{52} \times \frac{20}{84} \times \frac{27}{42} \times \frac{14}{1} = \text{fallers per minute} = 375$$

$$\text{Pulley speed} = \frac{375 \times 52 \times 84 \times 42}{33 \times 20 \times 27 \times 14} = 276 \text{ r.p.m.}$$

4. Again in diagram Fig. 31 if the speed of the main shaft is 200 r.p.m., the drum is 12 in. diameter, and the production is to be $3\frac{1}{2}$ cwt. per hour from two deliveries, we have to find the weight of the sliver in pounds per 100 yd. Taking the draft pinion as 64, and calling the weight of the sliver in pounds per 100 yd. by the letter P , the production in hundredweights per hour will be

$$\frac{200}{1} \times \frac{12}{12} \times \frac{33}{64} \times \frac{2.5 \times 3.14}{36} \times \frac{P}{100} \times \frac{1}{112} \times \frac{60}{1} \times \frac{2}{1}$$

As this must be equal to $3\frac{1}{2}$ cwt.

$$\frac{200}{1} \times \frac{12}{12} \times \frac{33}{64} \times \frac{2.5 \times 3.14}{36} \times \frac{P}{100} \times \frac{1}{112} \times \frac{60}{1} \times \frac{2}{1} = \frac{7}{2}$$

$$P = \frac{7 \times 12 \times 64 \times 36 \times 100 \times 112}{2 \times 200 \times 12 \times 33 \times 2.5 \times 3.14 \times 60 \times 2} = 14\frac{1}{2} \text{ lb.}$$

5. Referring to Fig. 46, it may be required to have only 36 lb. pressure per inch of roller face, and the position of the weight on the lever *A* is to be found which will give this. As stated on page 111, there is only one set of levers and weight to the pair of pressing rollers, and the face of each roller of the pair is 4 in. broad.

Taking *S* as the required distance of the weight from the fulcrum *B*, the total pressure on the rollers in pounds will be

$$\frac{15}{1} \times \frac{S}{2.5} \times \frac{10}{2}$$

and, there being 8 in. of face on the two rollers, this total pressure will be 36×8 lb. so that

$$\frac{15}{1} \times \frac{S}{2.5} \times \frac{10}{2} = 36 \times 8$$

$$S = \frac{36 \times 8 \times 2.5 \times 2}{15 \times 10} = 9.6 \text{ in.}$$

or the weight must be hung on the lever *A* at a point 9.6 in. from the fulcrum *B*.

CHAPTER VI

THE ROVING FRAME

Arrangement and Functions

THE roving frame is the last of the series of machines over which the jute passes in the preparing department. On this machine the sliver is finally drawn out to the size most convenient for the spinning process, which follows next. The size to which it is drawn is small and the sliver is, as a consequence, rather delicate; a slight twist is therefore imparted to it, which not only strengthens it, but also, if the slackening out of this twist on the spinning frame is carefully adjusted, enables it to be drawn out evenly and uniformly when being spun. The twisted sliver, which is called *rove*, has then to be wound on to a bobbin, this being the most convenient form for the spinning frame.

The machine is simply a long drawing frame, usually of the spiral type, with 7 to 10 heads having 8 to 10 deliveries each, which is fitted with gearing and mechanism to twist these deliveries and wind them separately on to bobbins. Fig. 49 shows the arrangement of the drawing frame part of the machine in its position relatively to the twisting and winding on parts; the drawing frame consisting of the retaining rollers, gills, and drawing rollers; the twisting and winding on parts consisting of the spindles and flyers, bobbins, and builder. The sliver to be treated is taken in by the retaining rollers, is carried forward and drawn out by the drawing rollers in the usual way. There is no doubling. As shown in Fig. 49, each sliver as it comes from the drawing rollers passes through a hole in the top of the flyer, out at the side, along the shoulder and

down the opposite leg of the flyer, and finally through the eye of the flyer on to the bobbin.

Twisting

If the spindles and flyers remained stationary and the bobbins were rotated fast enough to take up the

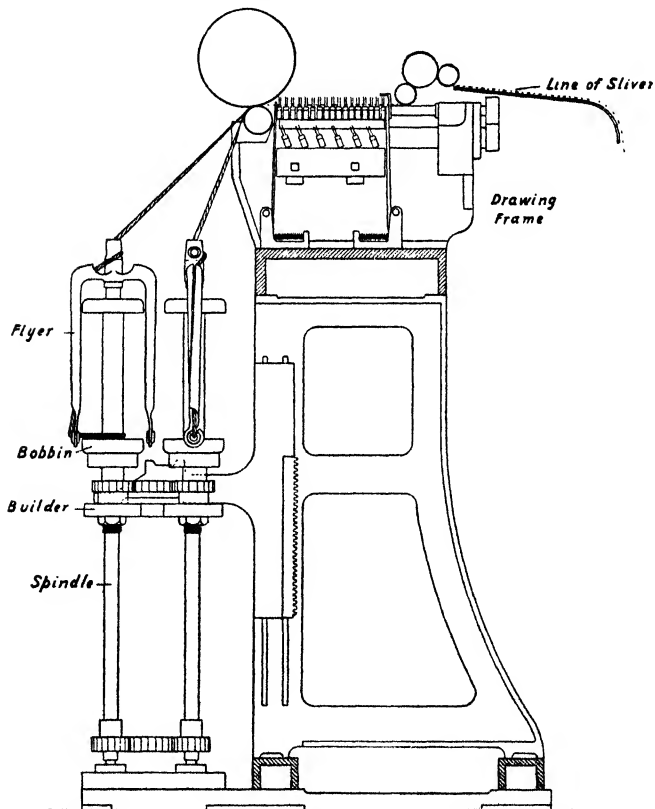

FIG. 49

slivers as they were delivered, the slivers would simply be pulled down through the flyers and wound on the bobbins without twist of any kind. If, again, the bobbins were kept stationary and the spindles and flyers rotated at a speed sufficient to wind the slivers on the bobbins, the slivers would be laid on with a small amount of twist due to the revolutions of the flyers. The amount of twist given to the sliver, however, being only one turn for each revolution of a flyer on the corresponding length laid on by that revolution, would be far short of what is required, and would vary as the bobbin circumference increased. In practice, therefore, it is necessary to increase the twist and to make it uniform by causing the spindles to go at a definite, fast, uniform speed relatively to the delivery. Each revolution of the spindles would then put one turn of twist into the length of sliver delivered during that revolution, so that obtaining any required twist is simply a matter of adjusting the length delivered relatively to the spindle revolutions.

Winding On

With the spindles being made to run so much faster the problem arises of driving the bobbins at such a speed that the rove will be wound on to them at exactly the rate at which it is being delivered. Evidently, no rove would be wound on to the bobbin if the bobbin and flyer were running at the same number of revolutions and the eye of the flyer were always opposite the same part of the bobbin. To get winding on there must be a difference between the revolutions of the flyer and those of the bobbin; that is, the bobbin must be made to run either faster or slower than the flyer, the revolutions of which, being determined by the amount of twist which must be put on the sliver,

are fixed. The difference between the revolutions of the flyer and those of the bobbin, made in order to get winding-on, we shall call the *winding-on revolutions*. The actual winding-on motion, or *uptake*, at any time will be the winding-on revolutions multiplied by the circumference of the bobbin at that time, and this, to ensure the rove being wound on steadily with an even tension, must always be equal to the delivery.

We have, then, the following—

(a) Winding-on revolutions = difference between flyer and bobbin revolutions;

(b) Winding-on revolutions \times circumference of bobbin = winding-on motion;

Winding-on motion must be equal to delivery.

(c) Winding-on revolutions \times circumference of bobbin = delivery,

or (d) Winding-on revolutions = $\frac{\text{delivery}}{\text{circumference of bobbin}}$.

The delivery being constant, as layer after layer is put on the bobbin, its circumference will become larger and the winding-on revolutions will become less and less. In jute spinning, for mechanical reasons, the difference between bobbin and flyer revolutions is made by making the bobbins go slower than the flyers, so that the winding-on revolutions at any time will simply be the number of revolutions the bobbins are making less than the flyers. If, then, the winding-on revolutions become less and less as the bobbins fill, the revolutions of the bobbins will at the same time become more and more.

This speeding up of the bobbins of the jute roving as they fill may be shown graphically by means of the diagram given in Fig. 50. The three outer circles *A* represent the path of the flyer eye, and the three inner circles *B*, the bobbin circumferences at different stages of the filling, the sizes of these circumferences being: Empty, 5 in.; half-full (approx.), 10 in.; and full, 15 in. *C* is the flyer eye, and *CD* the rove passing

from flyer eye to bobbin. The arrows show the direction of rotation of the flyer.

Let us suppose that the flyer makes one revolution in each case, and that during this time 1 in. of material is delivered. This material has to be wound on the bobbin. If the bobbin in each case had made one revolution along with the flyer, there would be no winding-on and the inch of material would simply

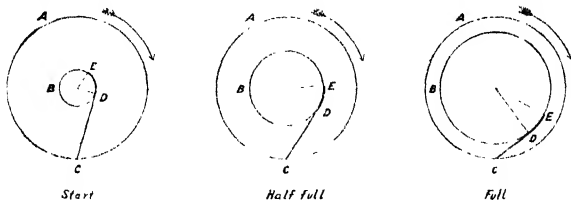

FIG. 50

cause an inch of slackness on the length of rove CD . To wind this on, the bobbin should, in each case, have lagged behind the flyer just enough for the inch of rove to be laid along the circumference of the bobbin, as shown at DE . With the empty bobbin the circumference will lag behind 1 in. on a 5 in. circumference, or $\frac{1}{5}$ revolution; with the half-filled bobbin, it will lag 1 in. on a 10 in. circumference, or $\frac{1}{10}$ revolution; and with the full bobbin it will lag 1 in. on a 15 in. circumference, or $\frac{1}{15}$ revolution. The larger the circumference of the bobbin, therefore, the less must it lag behind the flyer, or, to put it shortly, *the revolutions of the bobbin must increase as it fills.*

The Builder

The rove, or twisted sliver, must be wound on the bobbin in uniform, compact layers. While the winding-on is proceeding, therefore, the builder carrying the

bobbins is driven up and down with a slow, steady motion so as to bring the whole length of the bobbin between the flanges successively opposite the eye of the flyer, and thus build the rove compactly and evenly on the bobbin until it is filled. The whole process of filling the bobbins, from the start with the empty bobbins to the replacing of the full by the next set of empties, is called a *shift*.

In Fig. 51 we have diagrams of (a) an empty bobbin

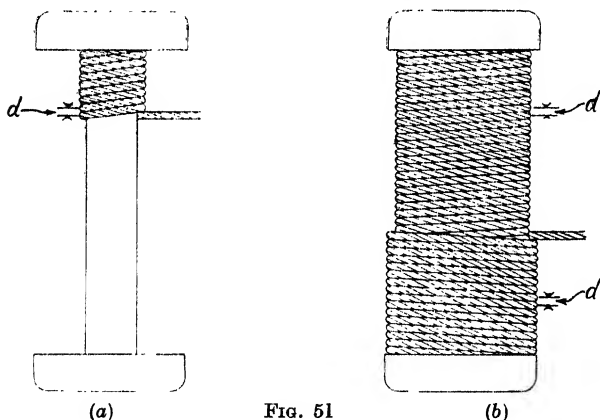

FIG. 51

and (b) a full bobbin, showing the spirals of rove. These spirals, being evenly and compactly laid on, the distance from the centre of one spiral to the centre of the next will be equal to the thickness of the rove, i.e. the rove diameter. When a spiral of rove is being wound on, therefore, the builder with the bobbins must move a distance equal to a rove diameter. Now, the length of a spiral being simply that of the bobbin circumference, the spiral on an empty bobbin will be much shorter than that on a full bobbin, so that at the beginning of the shift the builder will move the distance

of one rove diameter while a short spiral is being delivered, and at the end of the shift, the same distance while a much longer spiral is delivered. As the rate of rove delivery is constant throughout the filling of the bobbins, the builder must travel much more quickly at the beginning of the shift than at the end, the speed changing with each layer put on.

Drives and Gearing

We can see now what drives must be provided in the roving frame. The drawing rollers, retaining rollers, and fallers of the drawing frame part must all be driven at their proper relative speeds; to give a uniform twist to the rove a definite uniform speed must be given to the spindles; to obtain regularity in the winding-on, the drive to the bobbins must be of such a nature that the bobbin speed may be varied from slow to fast as the bobbins fill; and, lastly, to build the rove on the bobbin evenly and compactly, the builder must be driven steadily up and down, moderately fast to begin with, and slowing down as the bobbins fill.

An idea of how these different drives are arranged may be got from the diagram, Fig. 52, which is a lay-out of the machine showing the gearing and the drives to the principal parts in a jute roving. These different drives will be described as the necessity arises when they are being dealt with.

Drawing Frame Drives and Calculations

For the sake of convenience we shall first find the speed of the frame shaft and use it when working out the speeds of the other parts. Taking the speed of the main shaft as 192 r.p.m., and the drum as 30 in., the speed of the frame shaft will be

$$\frac{192}{1} \times \frac{30}{24} = 240 \text{ r.p.m.}$$

126 JUTE SPINNING CALCULATIONS

The drawing frame part of the machine is in the upper part of the diagram, the drives to it being as follows: The twist pinion on the end of the frame shaft drives the 60 on the end of the drawing roller; a short distance along the drawing roller from the 60 a 34 wheel drives the draft pinion, which, for the sake of convenience, is on the back shaft in the roving frame; from the back shaft we have the two usual drives, one to the pitch pin shafts on which are the bevels for driving the screws, and the other, from the 25 on the pulley end of the back shaft, through a small intermediate and the double intermediate 68/25 to the 69 on the end of the retaining roller.

Taking the twist pinion as 30 teeth and the draft pinion as 36, we may work out the surface speeds and speed ratios of the different parts of the drawing frame as follows—

$$\text{Drawing roller: } \frac{240}{1} \times \frac{30}{60} = 120 \text{ r.p.m.}$$

$$\frac{240}{1} \times \frac{30}{60} \times 2.25 \times 3.14 = 848 \text{ in. per min.}$$

$$\text{Retaining roller: } \frac{240}{1} \times \frac{30}{60} \times \frac{34}{36} \times \frac{25}{68} \times \frac{25}{69} \times \frac{2 \times 3.14}{1} = 94.8 \text{ in.}$$

$$\text{Faller drive: } \frac{240}{1} \times \frac{30}{60} \times \frac{34}{36} \times \frac{22}{22} \times \frac{24}{16} = 170 \text{ fallers per min.}$$

$$\begin{aligned} \text{Faller lead: } \quad \frac{69}{25} \times \frac{68}{25} \times \frac{22}{22} \times \frac{24}{16} \times \frac{9}{16} \times \frac{1}{2 \times 3.14} \\ = 1.008 \text{ times, or } 0.8 \text{ per cent lead} \end{aligned}$$

$$\text{Draft: } \frac{69}{25} \times \frac{68}{25} \times \frac{DP}{34} \times \frac{24}{2} = 4.02 = \text{draft}$$

$$\frac{1}{4.02} \text{ being draft constant}$$

$$\text{since } \frac{DP}{4.02} = \text{draft, draft} \times 4.02 = DP.$$

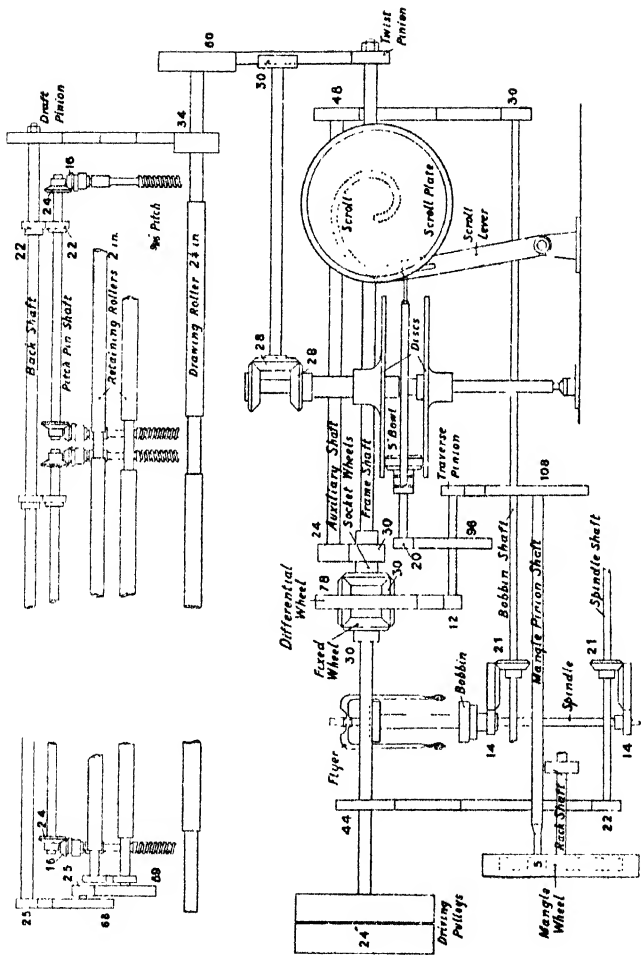

FIG. 52

It should be noted particularly that, in this draft calculation, the draft pinion, DP , is on the top line and that this causes the draft constant to be a fraction.

Twist Calculation

The twist on the rove is obtained from the revolutions of the spindles relatively to the delivery—one revolution of the spindles giving one turn to the length of rove delivered during that revolution. The amount of twist is usually expressed as so many turns on each inch of rove, so that in the twist calculation what we require to find is simply the number of revolutions made by the spindles for each inch delivered. To do this, we take the drawing roller as running at one revolution per minute and as driving the spindles through the gearing between them. This gearing is as follows: The 60 wheel on the drawing roller end drives the twist pinion on the frame shaft; at the other end of the frame shaft, just inside the pulleys, a 44 wheel drives a 22 on the spindle shaft; on this shaft a series of 21-toothed bevels drive, through what are known as the *crown wheels*, the 14-toothed wheels on the spindles. Each crown wheel consists of a bevel wheel compounded with a spur wheel of the same number of teeth, the two together acting simply as a single intermediate.

The calculation for the amount of twist put on the rove may be represented by

$$\frac{\text{Spindle revolutions in a given time}}{\text{Delivery in inches in same time}} = \text{turns per inch on rove}$$

The drawing roller at 1 r.p.m. will deliver 2.25×3.14 in. per minute and, with the gearing between them, will drive the spindles at

$$\frac{60}{TP} \times \frac{44}{22} \times \frac{21}{14} \text{ r.p.m.}$$

Dividing this by the corresponding delivery in inches, we have

$$\frac{60}{TP} \times \frac{44}{22} \times \frac{21}{14} \times \frac{1}{2.25 \times 3.14} = \frac{25.46}{TP} = \text{turns per inch on rove}$$

25.46 being the value of the figures in the calculation,

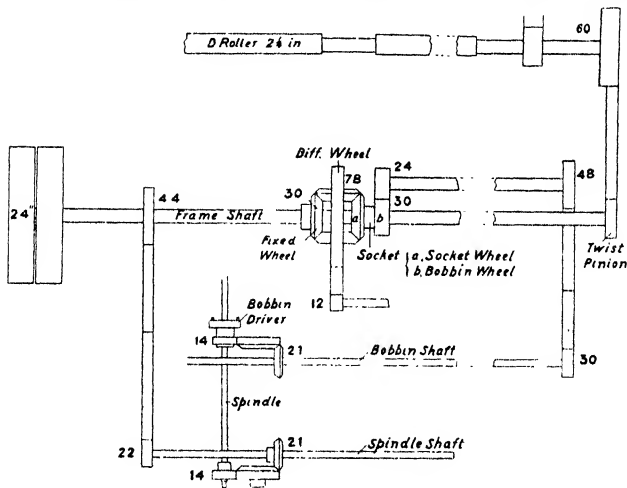

FIG. 53

which do not change, is therefore the *constant for the twist*; and as

$$\frac{25.46}{TP} = \text{turns per inch,} \quad \frac{25.46}{\text{turns per in.}} = TP$$

Winding-on Mechanism

The drives to the spindle and bobbin are, for the sake of clearness, given in diagrammatic form in Fig. 53, detached from the rest of the gearing. The two drives are as follows: To the spindles, a 44 on the frame shaft at the pulley end drives, through two intermediates,

a 22 on the end of the spindle shaft, and on this shaft, as we have already seen, a series of 21's drive the 14's on the spindles. The drive to the bobbins is more complicated; a 30 bevel fixed to the frame shaft drives, through a pair of bevels mounted on the axle of the differential wheel, a 30 bevel on the other side of the differential wheel; this 30 bevel wheel, known as the *socket wheel*, is compounded with the 30 spur wheel alongside it, called the *bobbin-wheel*, the two being fixed on the same socket running loose on the frame shaft. The 30 bobbin-wheel drives a 24 on the auxiliary shaft; on the other end of this shaft a 48 drives, through two intermediates, a 30 on the end of the bobbin shaft, and on this shaft is a series of 21-toothed wheels driving the 14's on the bobbin drivers.

The figures for the two drives, *with the differential wheel standing*, are as follows—

$$\text{Spindles: } \frac{240}{1} \times \frac{44}{22} \times \frac{21}{14} = 240 \times 3 = 720 \text{ r.p.m.}$$

$$\text{Socket and bobbin wheels: } \frac{240}{1} \times \frac{30}{30} = 240 \text{ r.p.m.}$$

Bobbins, from bobbin wheel:

$$\frac{240}{1} \times \frac{30}{24} \times \frac{48}{30} \times \frac{21}{14} = 240 \times 3 = 720 \text{ r.p.m.}$$

From these figures we see that the drives from the frame shaft to the spindles and from the bobbin wheel to the bobbins have exactly the same value, 3 to 1; and that, when the differential wheel is stationary, the socket wheel, and with it the bobbin wheel, will have the same revolutions as the frame shaft; the bobbins will have the same number of revolutions as the flyers, and there can be no winding-on.

The difference in revolutions between flyer and bobbin, necessary to give the winding-on motion, is

obtained from the rotation of the differential wheel. According to the *direction* in which this wheel is made to rotate, the speed of the socket wheel may be either increased or decreased, and according to the *speed* at which it is made to rotate this increase will be either greater or less. Any change in the speed of the socket wheel affects that of the bobbin wheel, which, of course, communicates the change to the bobbins, so that, as the socket wheel is made to run faster or slower than

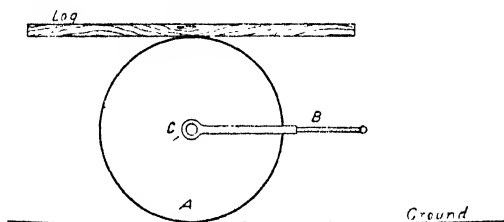

FIG. 54

the frame shaft by the rotation of the differential wheel, the bobbins will be made to run faster or slower than the flyers, and so give the winding-on revolutions. These winding-on revolutions, as we have seen, must be varied as the bobbins fill. The function, therefore, of the differential motion is simply to carry the drive from the fixed wheel on the one side of it to the socket wheel on the other in such a way that the revolutions of the socket may be easily varied. It will be necessary now to consider very fully the effect of the rotation of the differential wheel, both with regard to direction and speed.

The Differential Motion

In Fig. 54 if the roller *A* were firmly attached to the connecting rod *B* so that it could not revolve and were pushed along by it, the log lying on the top of the roller

would simply be carried along without changing its position on the roller. But if the roller were free to revolve and were again pushed along by the connecting rod, the log would receive two motions, one from the forward movement of the roller and one from its rotation, so that the result would be that the log would now move forward at twice the rate of the connecting rod, that is, at twice the rate of the

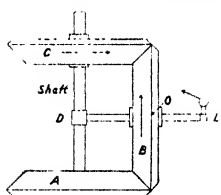

centre of the roller. The log evidently must move at the same rate as the part of the surface of the roller on which it bears, so that we may say that a point in the upper surface of a rolling wheel or roller has twice the speed of the centre. A simple, elementary experiment will verify this.

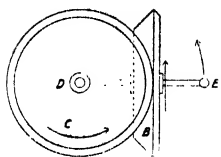

FIG. 55

In Fig. 55 we have three equal-sized bevels, *A*, *B*, and *C*. Of these three bevels *A* is fixed to the upright shaft and is stationary; *B*, carried on the arm *DE* centred on the shaft, is free to roll round *A*; and *C*, loose on the shaft, gears with *B*. If the arm *DE* be now swung round and the bevel *B* be thus made to roll round *A*, the upper rim of *B* will move twice as fast as its centre *O*. The rim of the bevel *C*, gearing as it does with the upper rim of the bevel *B*, must have the same speed as the rim of *B* and therefore will also move twice as fast as the centre *O*. Now, the rim of the bevel *C* and the centre *O* of the bevel *B* are at the same distance from the upright shaft, and will thus move round it in circles of the same size; the rim of *C*, therefore, moving at twice the speed of the centre *O*, will make two revolutions while the centre *O* goes once round the shaft. The centre *O* is carried round by

the arm DE , so that the bevel C will make two revolutions while the arm DE makes one. The directions of rotation of the different parts are indicated by arrows in the diagram; it will easily be seen from them that the bevel C rotates in the same direction as the arm DE .

Fig. 56 is a diagram of the differential motion, lettered to correspond with Fig. 55. In it we have the bevel A fixed to the frame shaft, the bevel B with its centre O

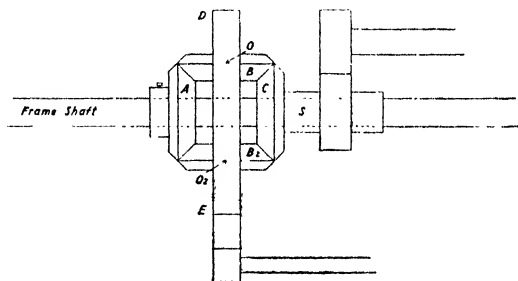

FIG. 56

on the axis of the differential wheel DE , and, gearing with B , the bevel C fixed on the socket S running loose on the frame shaft, all three bevels being equal in size. The bevel B_2 with its centre O_2 also on the axis of the differential wheel is simply a duplicate of the bevel B . If, now, DE be made to rotate, the centre O will be carried round with it, and the bevel B will be made to roll round A . As we saw in the previous paragraph, one revolution of the differential wheel, which takes the place of the arm DE in Fig. 55, will make the bevel C go two revolutions in the same direction.

We must now see what will be the effect on the speed of the socket wheel (Fig. 53) of combining the two drives to it, the one from the frame shaft and the

other from the differential wheel. Let us first suppose that the frame shaft is making 240 revolutions per minute clockwise and the differential wheel 30 revolutions per minute anti-clockwise. The frame shaft will drive the socket wheel

$$240 \times \frac{30}{30} = 240 \text{ r.p.m. anti-clockwise}$$

the differential wheel will drive it

$$30 \times 2 = 60 \text{ r.p.m. anti-clockwise}$$

Combining the two, we have

$$\begin{array}{r} 240 \text{ r.p.m. anti-clockwise from the frame shaft} \\ \underline{60 \text{ r.p.m. anti-clockwise from the differential wheel}} \\ 300 \text{ r.p.m. anti-clockwise in all} \\ \hline \end{array}$$

Let us next suppose that the frame shaft is making 240 revolutions per minute clockwise as before, and the differential wheel 30 revolutions per minute, but this time clockwise—the same direction as the frame shaft. The frame shaft will, as before, drive the socket wheel

$$240 \times \frac{30}{30} = 240 \text{ r.p.m. anti-clockwise}$$

the differential wheel will drive it

$$30 \times 2 = 60 \text{ r.p.m. clockwise}$$

Combining these, we have

$$\begin{array}{r} 240 \text{ r.p.m. anti-clockwise from the frame shaft} \\ \underline{60 \text{ r.p.m. clockwise from the differential wheel}} \\ 180 \text{ r.p.m. anti-clockwise in all} \\ \hline \end{array}$$

The frame shaft, therefore, drives the socket wheel at a speed equal to its own, and the effect of the rotation of the differential wheel is that each revolution it makes in the opposite direction to the frame shaft

adds two revolutions to the socket wheel speed, and each revolution it makes in the same direction as the frame shaft *deducts* two revolutions from the socket wheel speed; or, more generally, *that each revolution of the differential wheel makes a difference of two revolutions between the revolutions of the frame shaft and that of the socket wheel.*

In jute spinning the differential wheel is always driven in the same direction as the frame shaft. As we have just seen, the frame shaft would, if the differential wheel were stationary, drive the socket wheel at the same speed as itself, and the bobbins would run at the same speed as the flyers. But when the differential wheel is made to rotate in the same direction as the frame shaft, the socket wheel, having its speed reduced, will have less speed than the frame shaft; this, in turn, will cause the bobbins to have less speed than the flyers and the difference between the revolutions of bobbin and flyer will give the winding-on revolutions. By a special mechanism, the speed of the differential wheel may be altered during the shift. This enables the speed of the socket wheel to be varied, and so provides the means of varying the winding-on revolutions to suit the increasing diameter of the bobbins as they fill.

To make all this clear, we shall work out the changes in the bobbin diameter, winding-on revolutions, speed of the differential, and bobbin speed during the filling of a shift, taking the particulars from the roving frame we are considering. The differential wheel in this roving is driven in the same direction as the frame shaft; each revolution of it, therefore, will lessen the speed of the socket wheel by two revolutions. Each revolution of the frame shaft gives three revolutions of the spindles, and each revolution of the socket wheel gives three of the bobbins, so that one revolution of the differential wheel will make the bobbin revolutions

136 JUTE SPINNING CALCULATIONS

$2 \times 3 = 6$ revolutions less than the flyers, that is, will give six winding-on revolutions.

We have seen that

$$\text{winding-on revolutions} = \frac{\text{delivery}}{\text{circumference of bobbin}}$$

or, calling the bobbin diameter at any time d , and using the drawing roller speed worked out on page 126,

$$\text{winding-on revolutions} = \frac{120 \times 2\frac{1}{2} \times 3.14}{d \times 3.14} = \frac{120 \times 2\frac{1}{2}}{d}$$

Again, the bobbin revolutions

$$= \text{spindle revolutions} - \text{winding-on revolutions}$$

$$= 720 - \text{winding-on revolutions.}$$

The barrel of the empty bobbin is $1\frac{1}{8}$ in. diameter, and we shall take the increase in the bobbin diameter to be $\frac{1}{8}$ in. for each layer put on; this increase though, in practice, large is taken in order that the table may not be too long. Using the foregoing particulars and formulae, we can now make out the table as follows—

Bobbin diameter d	Winding-on revolutions $\frac{120 \times 2\frac{1}{2}}{d}$	Differential wheel revolutions Winding-on revolutions $\frac{\quad}{6}$	Bobbin revolutions $720 - \text{winding-on revolutions}$
$1\frac{1}{8}$	166	27.6	554
$2\frac{1}{8}$	127	21	593
$2\frac{3}{8}$	102.9	17.15	617.1
$3\frac{1}{8}$	86.4	14.4	633.6
$3\frac{3}{8}$	74.5	12.4	645.5
$4\frac{1}{8}$	65.4	10.9	654.6
$4\frac{3}{8}$	58.4	9.7	661.6
$5\frac{1}{8}$	52.7	8.8	667.3

This table shows very clearly how, as the bobbins fill—

The winding-on revolutions decrease;

The differential wheel is slowed down; and

The bobbins are speeded up.

Regulation of Winding-on Motion

The drive to the differential wheel is shown, detached from the main lay-out, in Fig. 57. This drive, to avoid confusion, should be taken from the *drawing roller*, not, as is usually done, from the frame shaft. Evidently, the delivering roller must be directly connected by gearing with the winding-on mechanism. The 60 on the end of the drawing roller drives the 30

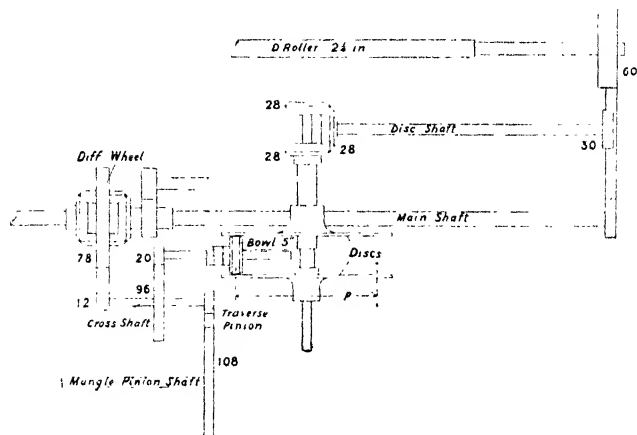

FIG. 57

on the end of the disc shaft; on the other end of this shaft is a 28 bevel which drives two 28 bevels, of which the top bevel is fixed on the shaft carrying the bottom disc, and the bottom bevel on the socket carrying the top disc, the discs being thus driven in opposite directions. Between the discs and driven by them is a 5 in. bowl on the *bowl shaft*; the bowl carries the bowl shaft round with it by means of a long feather, or key, fixed on the bowl shaft, which also permits the bowl to be shifted along the bowl shaft to different diameters on

the discs. On the left end of the bowl shaft a 20 pinion drives a 96 wheel on the cross shaft. From this shaft there are two drives; on the left a 12 pinion drives, through a small intermediate, the 78 differential wheel, while, on the right, the traverse pinion begins the builder drive.

We will take it now that the drawing roller is running at 1 r.p.m., giving a delivery of $2\frac{1}{4} \times 3.14$ in. and that it drives the differential through the gearing indicated above. Calling the working diameter of the plates, that is, the *diameter* on the plates at which the bowl is working at any time, by the letter P , the drawing roller will drive the differential wheel at

$$\frac{60}{30} \times \frac{28}{28} \times \frac{P}{5} \times \frac{20}{96} \times \frac{12}{78} \text{ revolutions}$$

in the same direction as the main shaft. Each revolution of the differential wheel in this direction makes the socket wheel speed two revolutions less than that of the main shaft: the socket wheel speed will therefore be

$$\frac{60}{30} \times \frac{28}{28} \times \frac{P}{5} \times \frac{20}{96} \times \frac{12}{78} \times \frac{2}{1} \text{ revolutions less than the frame shaft}$$

and the bobbin speed will be

$$\frac{60}{30} \times \frac{28}{28} \times \frac{P}{5} \times \frac{20}{96} \times \frac{12}{78} \times \frac{2}{1} \times \frac{3}{1} \text{ revolutions less than the flyers}$$

giving this amount of winding-on revolutions. The winding-on revolutions \times bobbin circumference at any time is the winding-on motion, and this must be equal to the delivery. Calling the bobbin diameter at the corresponding time by the letter d , we now have

$$\frac{60}{30} \times \frac{28}{28} \times \frac{P}{5} \times \frac{20}{96} \times \frac{12}{78} \times \frac{2}{1} \times \frac{3}{1} \times \frac{d \times 3.14}{1} = \frac{2\frac{1}{4} \times 3.14}{1}$$

$$\text{whence } P = \frac{2\frac{1}{4} \times 3.14 \times 30 \times 28 \times 5 \times 96 \times 78}{60 \times 28 \times 20 \times 12 \times 2 \times 3 \times d \times 3.14} = \frac{29.25}{d}$$

$$\text{or, } P \times d = 29.25;$$

that is, the working diameter of the plates at any time \times diameter of the bobbins at the same time must be equal to 29.25 in order that the winding-on may balance the delivery.

Discs and Bowl

We shall now work out the corresponding working diameters of the plates for the different diameters of the bobbins as they fill, in order to see the nature of the change in the bowl's position with each layer put on. It is evident that P , the working diameter of the plates, must become smaller as d , the diameter of the bobbins, becomes larger; that is, the bowl is shifted towards the centre of the plates as the bobbins fill. Taking again the figures previously used for the rove diameters, namely, $1\frac{5}{8}$ in. for the empty bobbin, and each layer as adding $\frac{1}{2}$ in. to the bobbin diameter, we have the following table—

Bobbin diameter in in.	Working diameter of plates $P = \frac{29\frac{1}{4}}{d}$	Distance of bowl from centre $\frac{P}{2}$	Shifts of bowl towards centre of plates
$1\frac{5}{8}$	18	9	—
$2\frac{1}{8}$	13.77	6.885	2.115
$2\frac{3}{8}$	11.14	5.57	1.33
$3\frac{1}{8}$	9.36	4.68	.89
$3\frac{3}{8}$	8.07	4.035	.645
$4\frac{1}{8}$	7.09	3.545	.49
$4\frac{3}{8}$	6.324	3.162	.383
$5\frac{1}{8}$	5.707	2.853	.31

In the first column are the different bobbin diameters; the second column gives the corresponding working diameters of the plates obtained by using the formula, $P = \frac{29\frac{1}{4}}{d}$; the third column gives the corresponding

distances of the bowl from the centre of the discs, i.e. simply the halves of the working diameters of the plates given in column 2; the fourth column shows the distance which the bowl must move after each layer is put on, the amount of each shift being the difference between the new distance of the bowl from the centre and the one immediately preceding it.

Scroll, Scroll Plate, and Index Wheel

From the two last columns of the table in the preceding paragraph it will be seen that, at the beginning of the shift, the bowl must start working near the outside of the plates and must move toward the centre with each layer put on, and by a smaller amount each time. This movement of the bowl is obtained from and regulated by the movements of the scroll, the scroll plate, and the index wheel.

Fig. 58 is a diagrammatic representation of the *discs and bowl* with the regulating mechanism. A double strap *S* is fixed at one end to a collar working in a groove on the nave of the bowl *B*; to the bridge at the other end of the strap is fixed an eyebolt *E* by means of adjusting nuts, the eye of the eyebolt being attached to a stud fixed in a slot in the scroll lever *L*. At the top of this lever is another stud, or pin, *F*, which gears into the groove of the scroll cam. This scroll is a double curve cast on the inside of the scroll plate and is of such a shape that, when the scroll plate rotates, the curve will pull the stud *F* toward the centre of the scroll plate at a decreasing rate. The rotating movement of the scroll plate is intermittent; it is obtained by means of the weight *W* on the end of the chain attached to the curved lever *C* on the outside of the plate, and is regulated by the ratchet wheel *R* on the other end of the shaft *AD* to which the scroll plate is fixed. This ratchet wheel is called the *index*

wheel; two catches *P* and *Q* gear with the teeth of this index wheel, only one, however, being in contact

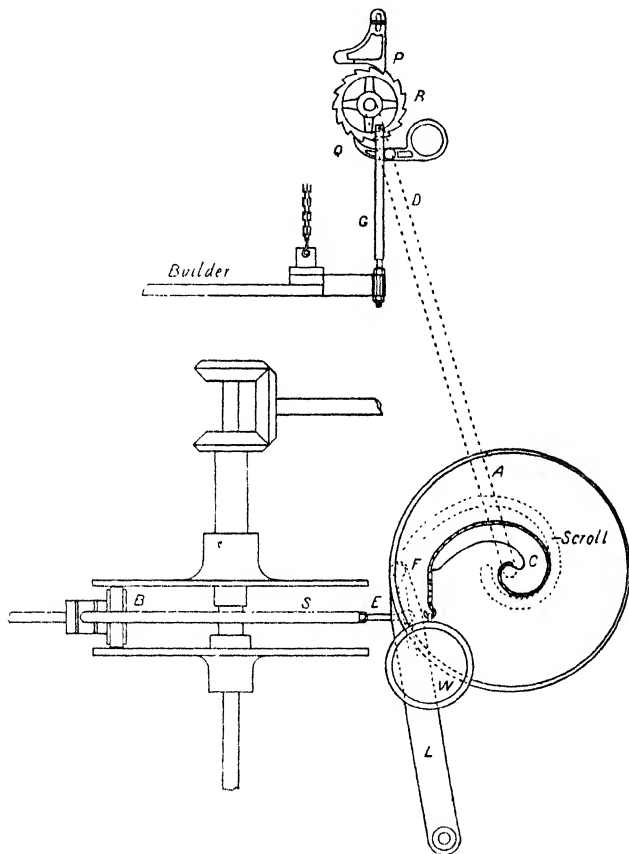

FIG. 58

with a tooth at a time, the other being at half tooth. A long rod *G* fixed to the builder works these catches.

When the builder reaches the top of its traverse, the top catch—which would be in gear at that time—is lifted and this allows the scroll plate to be pulled round by the weight W until it is stopped by the bottom catch coming into contact with a tooth of the index wheel. When the builder reaches the bottom of its traverse, the bottom catch is, in turn, pushed out of contact with the index wheel by a projection on the rod G , and the index wheel again moves round another half-tooth before it is stopped by the top catch. At the end of each traverse of the builder, therefore, the index wheel will move through part of a revolution equivalent to a half-tooth; the scroll plate on the same shaft will move to correspond, carrying the scroll along with it; the scroll will draw the pin F at the top of the lever L toward the centre of the scroll plate, thus moving the lever and drawing the bowl toward the centre of the plates. The shape of the scroll curve is such that, with equal movements of the scroll plate, the required shifts of the bowl—large at the beginning and small at the finish—are accurately obtained. At the end of each shift the index wheel and scroll plate are turned back to the starting position by means of a hand wheel on the shaft AD outside the index wheel.

Index wheels are always made the same diameter, but may vary in the number of teeth. Those wheels, therefore, with few teeth will have a pitch of tooth greater than those with many; this greater pitch will give a greater movement of the scroll as each half-tooth of the index wheel is slipped, and this will mean larger movements of the bowl toward the centre. Index wheels with many teeth will give smaller movements of the bowl.

An index wheel with few teeth of large pitch is usually called a *coarse* wheel, and one with many teeth of small pitch, *fine* one. We have seen (page 139) that P ,

the working diameter of the plates at any time, must be equal to $\frac{29\frac{1}{4}}{d}$, d being the corresponding diameter of the bobbin. With a heavy rove d will increase rapidly, P will decrease correspondingly, and the bowl will have to move toward the centre of the plates in comparatively large shifts, thus necessitating the use of a coarse index wheel. Similarly, with a light rove, d will increase slowly, P will decrease slowly, the bowl must make small shifts towards the centre, and a fine index wheel will be required.

The Builder Drive

With each spiral wound on to the bobbin the builder, as we have seen (page 124), must move a distance equal to the diameter of the rove. Taking the circumference of the bobbin as 5 in. at the start and 15 in. at the finish, the builder must, at the start, move a distance equal to a rove diameter while 5 in. are delivered; at the finish, it must move the same distance while 15 in. are delivered. As the delivery is uniform in speed, the builder must go three times faster at the start than at the finish of the shift.

Again, taking the same figures, but with reference to the winding-on, the winding-on revolutions will be

$$\text{at the start, } \frac{\text{delivery in in.}}{5 \text{ in.}}; \quad \text{at the finish, } \frac{\text{delivery in in.}}{15 \text{ in.}}$$

that is, the winding-on revolutions at the start will be three times those at the finish. As the winding-on revolutions are directly due to the rotation of the differential wheel, this wheel must go three times faster at the start than at the finish, which is just the same as with the builder. The speeds, therefore, of both builder and differential wheel have to vary during the shift to the same extent on account of the

change in the same factor, the diameter of the bobbin. The two drives, then, may be controlled by the same mechanism.

In Fig. 57 we have seen that there are two drives from the cross shaft which is driven by the bowl shaft; on the left a 12 pinion drives the differential wheel, while on the right the traverse change pinion gives the drive to the builder. This pinion drives the 108 wheel on the *mangle pinion shaft*; on the other end of this shaft, a small pinion of 5 teeth, the *mangle wheel pinion*, drives the mangle wheel on the end of the rack pinion shaft; and on this latter shaft are fixed the rack pinions gearing with the racks on the back of the large brackets carrying the builder. See Fig. 52.

The *traverse*, or up and down motion, is obtained by means of the *mangle wheel*, the nature of which is shown in Fig. 59. The teeth of this wheel are simply pins fixed in a circle to the flanged plate, or disc, and with a strengthening ring on top, a gap being left as shown between *c* and *d*. The mangle wheel pinion *e* may gear with either the outside or the inside of the mangle wheel, the shaft on which the pinion *e* is fixed being supported in a bearing *b* with just sufficient play to allow this. The pinion *e* always rotates in the same direction; when in gear with the inside of the wheel it will drive it in the same direction as itself, when in gear with the outside it will drive it in the opposite. The change from the one side to the other is effected at the ends of the circular arc; when either of these pins, *c* or *d*, comes into gear with the pinion, the pinion is forced to run round it by the guide piece and so to gear with the side opposite to that which it has been driving. The mangle wheel is thus driven first the one way and then the other, carrying the rack shaft and its pinions along with it and so driving the builder up and down.

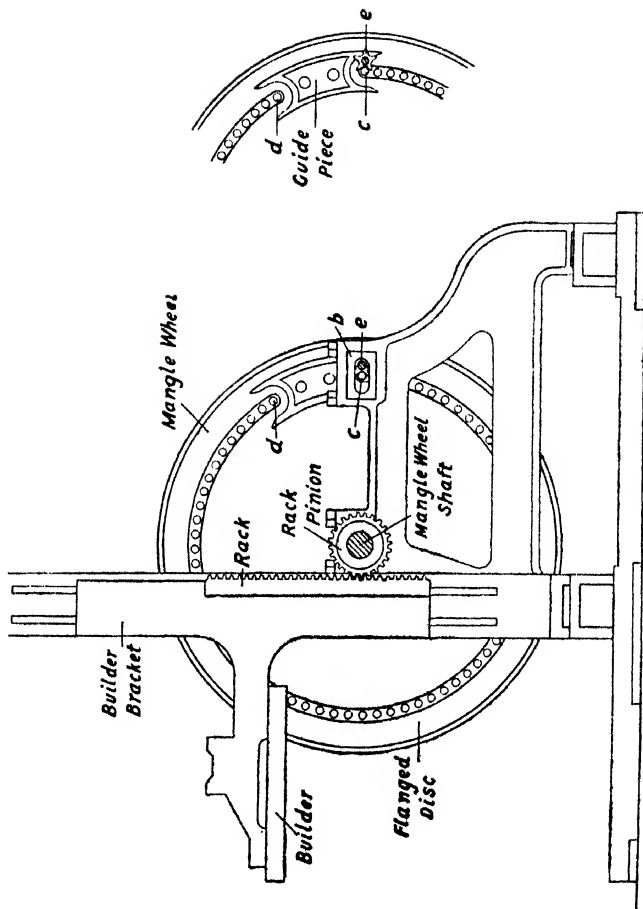

FIG 59

The number of teeth in the mangle wheel is such as to give the correct length of traverse to the builder. Altogether there are 73 teeth making up the arc, with 72 tooth spaces. When the mangle wheel has moved round an amount equivalent to these 72 spaces, the builder will have made the full traverse required, namely, 10 in. A movement of the mangle wheel, therefore, of $\frac{72}{10} = 7.2$ tooth spaces, or a rotation of the mangle wheel pinion of $\frac{7.2}{5} = 1.44$ revolutions, will be required for each inch of traverse.

The spirals of rove should be laid as compactly together as is possible without overlapping along the length of the bobbin. If n be the number of spirals of rove per inch of bobbin, and d be the diameter of the bobbin at any time in inches, each spiral will be $d \times 3.14$ in. in length; the length of the rove in inches on 1 in. along the bobbin will be $n \times d \times 3.14$, and the revolutions of the drawing roller, $2\frac{1}{4}$ in. in diameter, to give this quantity of rove, will be $\frac{n \times d \times 3.14}{2\frac{1}{4} \times 3.14}$. While delivering this, the builder must be driven a distance of 1 in., or, as we have just seen, the mangle wheel pinion must make 1.44 revolutions. We shall have, therefore,

$$\frac{n \times d \times 3.14}{2\frac{1}{4} \times 3.14} \times \frac{60}{30} \times \frac{28}{28} \times \frac{P}{5} \times \frac{20}{96} \times \frac{TrP}{108} = \frac{1.44}{1}$$

$$\text{Traverse pinion} = \frac{1.44 \times 2\frac{1}{4} \times 3.14 \times 30 \times 28 \times 5 \times 96 \times 108}{n \times d \times 3.14 \times 60 \times 28 \times P \times 20}$$

But we have seen that $P \times d$ must be equal to $29\frac{1}{4}$ in order that the winding-on may balance the delivery; we may therefore rewrite the above solution, substitut-

ing $29\frac{1}{4}$ for the $P \times d$ in the bottom line and cancelling the 3·14's, as follows—

$$\begin{aligned} \text{Traverse pinion} &= \frac{1\cdot44 \times 2\frac{1}{4} \times 30 \times 28 \times 5 \times 96 \times 108}{n \times 60 \times 28 \times 20 \times 29\frac{1}{4}} \\ &= \frac{143\cdot5}{n}, \text{ 143}\cdot5 \text{ being constant.} \end{aligned}$$

That is, 143·5 divided by the number of spirals required on the bobbin per inch of length will give the number of teeth in the traverse pinion. The number of spirals per inch necessary may be tested with reasonable accuracy by winding on, as closely as is possible by hand, sufficient rove to cover 3 in. of the length of an empty bobbin, counting the spirals, and dividing the amount by 3.

The above concludes the calculations for the gearing of the roving frame. As the calculations, however, are somewhat scattered throughout the preceding pages, it will be better to gather them together for handy reference. Taking

the speed of the main shaft as 192 r.p.m. ;
the drum as 30 in. :

Calling the twist pinion, TP

the draft pinion, DP

the traverse pinion, TrP

the working diameter of the plates at any time, P

the corresponding diameter of the bobbin, d

the number of spirals per inch on the bobbin, n

the calculations will be as follows—

Frame shaft—

$$192 \times \frac{30}{24} = 240 \text{ r.p.m.}$$

Drawing roller—

$$240 \times \frac{TP}{60} = \text{r.p.m.}$$

$$240 \times \frac{TP}{60} \times 2\frac{1}{4} \times 3\cdot14 = \text{inches delivered per minute}$$

148 JUTE SPINNING CALCULATIONS

Retaining roller—

$$\frac{240}{1} \times \frac{TP}{60} \times \frac{34}{DP} \times \frac{25}{68} \times \frac{25}{69} \times \frac{2 \times 3.14}{1} = \text{in. per min.}$$

Faller drive—

$$\frac{240}{1} \times \frac{TP}{60} \times \frac{34}{DP} \times \frac{22}{22} \times \frac{24}{16} = \text{fallers per min.}$$

Faller lead—

$$\frac{69}{25} \times \frac{68}{25} \times \frac{22}{22} \times \frac{24}{16} \times \frac{9}{16} \times \frac{1}{2 \times 3.14}$$

= 1.008 times, or 0.8 per cent lead

Draft—

$$\frac{69}{25} \times \frac{68}{25} \times \frac{DP}{34} \times \frac{2\frac{1}{2}}{2} = \frac{DP}{4.02} = \text{draft, } \frac{1}{4.02} \text{ being constant}$$

Twist—

$$\frac{60}{TP} \times \frac{44}{22} \times \frac{21}{14} \times \frac{1}{2\frac{1}{2} \times 3.14} = \frac{25.46}{TP}$$

= turns per inch, 25.46 being constant

Spindles—

$$\frac{240}{1} \times \frac{44}{22} \times \frac{21}{14} = 240 \times 3 = 720 \text{ r.p.m.}$$

Socket wheel—

$$\frac{240}{1} \times \frac{30}{30} = \text{differential wheel revolutions} \times 2 = \text{r.p.m.}$$

Bobbin drive—

$$\text{Socket r.p.m.} \times \frac{30}{24} \times \frac{48}{30} \times \frac{21}{14} = \text{socket r.p.m.} \times 3 = \text{r.p.m.}$$

Differential wheel—

$$\text{Drawing roller revolutions} \times \frac{60}{30} \times \frac{28}{28} \times \frac{P}{5} \times \frac{20}{96} \times \frac{12}{78} = \text{r.p.m.}$$

Winding-on motion—

$$\frac{60}{30} \times \frac{28}{28} \times \frac{P}{5} \times \frac{20}{96} \times \frac{12}{78} \times \frac{2}{1} \times \frac{30}{24} \times \frac{48}{30} \times \frac{21}{14} \times \frac{d \times 3.14}{1}$$

$$= \frac{2\frac{1}{4} \times 3.14}{1}, \text{ whence } P \times d = 29\frac{1}{4}$$

Traverse—

$$\frac{n \times d \times 3.14}{2\frac{1}{2} \times 3.14} \times \frac{60}{30} \times \frac{28}{28} \times \frac{P}{5} \times \frac{20}{96} \times \frac{TrP}{108} = \frac{72}{10} \times \frac{1}{5}$$

whence $TrP = \frac{143.5}{n}$, 143.5 being constant.

Roving Frame Adjustment

The adjustment of the roving to make a certain weight of rove may now be taken up. The weight of the rove is always given in pounds per *spangle* of 14,400 yd., while the sliver is given in pounds per 100 yd. The draft on the roving necessary to give the weight of rove required will be obtained by finding the weight of sliver in pounds per spangle and dividing it by the weight of the rove, thus

$$\frac{\text{weight of sliver in pounds per 100 yd.} \times \frac{14,400}{100}}{\text{weight of rove in pounds per spangle}} = \text{roving draft.}$$

The draft pinion may then be found by means of the draft constant; in the roving under consideration $\text{draft} \times 4.02 = \text{draft pinion}$. The turns per inch twist on the rove may be found by dividing any number from 6 to 9 by the square root of the weight of the rove in pounds per spangle or

$$\text{turns per in. on rove} = \frac{6 \text{ to } 9}{\sqrt{(\text{weight in pounds per spangle})}}$$

and the twist pinion may then be found by dividing the twist constant by the turns per inch.

The draft and twist pinions being put on, the frame may be started with any index wheel; though, if it is known how many layers may be put on the rove, an index wheel with half that number of teeth will be nearly correct. The tension of the rove and the compactness of the spirals must be carefully adjusted on the empty rove barrel. The tension on the rove is

adjusted by moving the bowl outwards if it is too slack, and inwards if it is too tight; the adjustment being made by means of the screws on the eyebolt connecting the double strap of the bowl to the pin on the scroll lever. The closeness of the spirals is adjusted by putting on a smaller traverse pinion if they are too open and a larger, if they are too close.

When the tension of the rove on the empty bobbin has been properly adjusted, if, as filling proceeds, the tension on the rove gradually works slack, the bowl is being shifted toward the centre of the plates by too large a shift each time; that is, the index wheel is too coarse and a finer is required. If the tension gradually works tight, the index wheel is too fine and a coarser is required. The index wheels supplied for a roving frame are often only for the odd numbers, e.g. 11, 13, 15, etc. It may happen, when the machine is being adjusted, that the coarser of two index wheels, two teeth different, causes the rove, as it fills, to work gradually slack, and the finer to work gradually tight. In such a case the bowl adjustment must not be meddled with; the adjustment must be made by shifting the pin in the slot of the scroll lever. The finer index wheel may be used and its rather small movement compensated for by raising the pin on the lever, or the coarser may be used if the pin is lowered.

Relative Weights of Roves of Different Sizes

In the diagram, Fig. 60, *A*, *B*, and *C* represent three roves the diameters of which are in the proportion 1 : 2 : 3. These roves, for purposes of calculation, may be taken as circular in cross section; the areas of the circles above *A*, *B*, and *C*, then, will represent the cross sections of these roves. About each circle is drawn in dotted lines a square with its sides touching the circumference of the circle; the side of the square

will be equal to the diameter of the circle in each case. As the area of a circle is always equal to $0.7854d^2$,

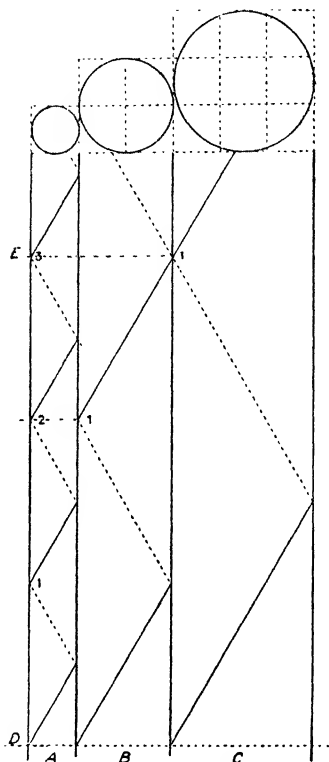

FIG. 60

where d is the diameter of the circle, the area of each circle will be 0.7854 of the area of its corresponding square. When comparing the areas of the circles, however, the factor 0.7854, being common to all, may

be cancelled out and we may say that the areas of the circles are proportional to the three squares.

The weight per unit length of each rove—that is, its weight in pounds per spangle—will be proportional to the area of its cross section. It will be seen that the square on *B* can be divided into four squares of the size of that above *A*, and the square above *C* into nine such squares; the sectional areas of the circles, then, will be in the proportion, 1 : 4 : 9, that is, in the proportion of the squares of their diameters, and the weights of the roves in pounds per spangle will be in the same proportion.

The proportional diameters of roves enter into calculations connected with changing sizes on a roving frame. Rove diameters are, however, very awkward to use in practice and it is necessary to use other factors which are handier. We have just seen that the weights of different roves are proportional to the squares of their diameters; conversely, the diameters must be proportional to the square roots of the weights. In calculations, therefore, involving proportional diameters of roves, the corresponding square roots of the weights in pounds per spangle are used instead.

Twist on Rove

Twist on a piece of rove is obtained by turning one end round its axis while the other end is held. In practice, the same effect is obtained on a roving frame from the revolutions of the flyers relatively to the delivery of the rove. The fibres of the rove are made to take a position at an angle to the length; this causes them to press against one another and the friction due to this pressure enables them to resist their being drawn apart. The angle which the fibres are made to take up when the rove is twisted indicates directly the *degree* of twist put on the rove, hard,

medium, or soft; the actual *amount* of twist is usually designated as so many turns per inch.

Referring again to the diagram, Fig. 60, in each of the spaces representing the roves there are drawn lines at an angle of 30° to the lines of the roves; these represent the spirals of single fibres on the surface. The three roves, then, having their fibres at the same angle, have the same degree of twist. Taking the number of full turns of the spiral on the same length for each of the roves, we find that, for the length *DE*, *A* has 3 turns; *B*, $1\frac{1}{2}$ turns; and *C*, 1 turn. Comparing these turns with the corresponding diameters of the roves, *A*, with diameter of 1, has 3 turns; *B*, with diameter of 2, has $1\frac{1}{2}$ turns, or half that of *A*; while *C*, with diameter of 3, has 1 turn, or one-third that of *A*. The examples could be multiplied but all would show a result of the same kind; this result, stated generally, is that the turns in the same length on different roves twisted to the same degree are inversely proportional to the diameters. Taking the length of rove as 1 in., and substituting the square roots of the weights for the diameters, we can state this in the more convenient form; the turns per inch on roves with the same degree of twist are inversely proportional to the square roots of the weights.

Changing Sizes

It is sometimes necessary to change the size of rove working on a roving frame. When doing so, certain changes on the machine are necessary; the draft may have to be changed requiring a different draft pinion; the turns per inch may be different, requiring a change in the twist pinion; then, according as the new rove is lighter or heavier, the builder will have to move either slower or faster and the bowl will have to move inwards on the plates by smaller or larger steps, with

corresponding changes in the traverse pinion and index wheel.

For the first example we shall take it that we have a roving frame running on 72 lb. rove with draft pinion 32; twist pinion, 36; traverse pinion, 24; and index wheel, 13; and that we have to change this frame to make 96 lb. rove with the same degree of twist and from the same sliver. The changes will be as follows—

1. DRAFT. Referring to the draft calculation on page 126 we saw that the draft constant was $\frac{1}{4}$ and that $\text{draft} \times 4 = \text{draft pinion}$; from this it is easy to see that a short draft requires a small draft pinion, and a long draft a large one. Again, taking the sliver from which a rove is being made as W lb. per 100 yd., the draft to give any weight of rove will be, as we have seen,

$$\frac{W \times 144}{\text{weight of rove}} = \text{draft.}$$

The heavier the rove, therefore, from any sliver, the shorter will be the draft, and the lighter the rove the longer will be the draft. Changing from 72 lb. to 96 lb. will require a proportionately shorter draft, implying a smaller draft pinion. The required draft pinion will therefore be

$$\frac{32}{1} \times \frac{72}{96} = 24, \text{ draft pinion for 96 lb.}$$

2. TWIST. Referring next to the twist calculation on page 129, we saw that the twist constant was 25.46 and that

$$\frac{25.46}{\text{twist pinion}} = \text{turns per in., or } \frac{25.46}{\text{turns per in.}} = \text{twist pinion.}$$

Obviously a smaller number of turns requires a larger twist pinion, and a larger number of turns, a smaller. The number of turns per inch on different roves with the same degree of twist varies, as we have seen,

inversely as the square roots of the weights; a 96 lb. rove will therefore have fewer turns per inch than a 72 lb. rove in the proportion $\sqrt{96} : \sqrt{72}$, and, as a smaller number of turns requires a larger twist pinion, the twist pinion for the 96 lb. rove will be

$$36 \times \frac{\sqrt{96}}{\sqrt{72}} = 36 \times \frac{9.8}{8.48} = 41.6 \text{ (say 42)}$$

3. BUILDER MOTION. The builder must move, with each spiral of rove put on, a distance equal to a rove diameter. With a change from a lighter to a heavier rove, the builder must move for each spiral a distance greater proportionally to the diameters of the two roves. Its speed, therefore, will be increased in the proportion of the square roots of the weights of two roves. A greater speed of builder requires a larger traverse pinion, so that the traverse pinion for the 96 lb. rove will be

$$24 \times \frac{\sqrt{96}}{\sqrt{72}} = 24 \times \frac{9.8}{8.48} = 27.7 \text{ (say 28)}$$

4. ROVE TENSION. The increase in the diameter of the bobbin, with each layer put on, is greater with a heavier rove than with a light in proportion to the diameters of the two. The bowl, in consequence, must move toward the centre of the plates in correspondingly larger steps, necessitating an index wheel with proportionately larger teeth. Larger teeth in the index wheel imply fewer in number. The change from a light rove to a heavier will require an index wheel with fewer teeth proportionately to the diameters of the two roves, that is, to the square roots of their weights. The index wheel, therefore, for the 96 lb. rove will be

$$13 \times \frac{\sqrt{72}}{\sqrt{96}} = 13 \times \frac{8.48}{9.8} = 11.25$$

An 11 index wheel will be used; to give the slight

additional fineness required by the 11·25, the pin in the scroll lever slot may be lowered.

For the second example we shall make the change from one size to another with different conditions from those of the first. The two roves will be from different weights of sliver and will not have the same degree of twist. The change will be from 72 lb. rove with 0·7 turns per inch and from 4 lb. sliver to 96 lb. rove with 0·9 turns per inch and from 5 lb. sliver. The pinions for the 72 lb. rove will be the same as before: draft pinion, 32; twist pinion, 36; traverse pinion, 24; and index wheel, 13. The changes in this case will be made as follows—

1. DRAFT. The best method of dealing with this is to find the drafts for the two roves and to use these to calculate the new draft pinion.

$$\text{The draft for the 72 lb. rove is } \frac{4 \times 144}{72} = 8$$

$$\text{For the 96 lb. rove it will be } \frac{5 \times 144}{96} = 7\frac{1}{2}$$

A draft pinion of 32 gave a draft of 8, a draft of $7\frac{1}{2}$ will require a smaller pinion in proportion, so that the draft pinion for the 96 lb. rove will be

$$32 \times \frac{7\cdot5}{8} = 30$$

2. TWIST. The twist on the 72 lb. rove is 0·7 turns per inch; the twist required on the 96 lb. rove is 0·9 turns per inch. We have seen that more turns per inch require a smaller pinion in proportion, so that

$$36 \times \frac{0\cdot7}{0\cdot9} = 28 = \text{twist pinion for 96 lb.}$$

3 and 4. TRAVERSE AND ROVE TENSION. The traverse pinion and index wheel for the 96 lb. rove are found in exactly the same way as before, as the conditions, so far as they are concerned, are unchanged.

To sum up, when changing a roving frame from one size to another the change pinions will be altered as follows—

1. From the same sliver and with the same degree of twist :

For a heavier rove the draft pinion will be smaller in proportion to the two weights ; the twist and traverse pinions and the teeth of the index wheel will be larger in proportion to the square roots of the weights.

For a lighter rove the draft pinion will be larger in proportion to the two weights ; the twist and traverse pinions and the teeth of the index wheel will be smaller in proportion to the square roots of the weights.

2. When the drafts and turns per inch are given or may be readily found :

In this case the drafts and turns per inch only must be used in the calculations for the relative pinions. For a shorter draft a smaller draft pinion will be required, and for less turns per inch a larger twist pinion will be required. The traverse pinion and index wheel for the new rove are found in the same way as in the first case.

These calculations for changing sizes on a roving frame are applicable to all types.

Other Methods of Regulating the Winding-on Motion.

(1) The Cone Drive

There are two other methods in ordinary use, besides the disc and bowl, of controlling the speed of the differential wheel, the *cones*, and the *expansion pulley*. These it will now be necessary to consider. In Fig. 61 we have the lay-out of the drive from the drawing roller to the differential wheel in a roving frame with a cone drive. An 80 wheel on the drawing roller drives, through two intermediates, a 36 on the top cone shaft ; the top cone on this shaft drives the bottom cone by

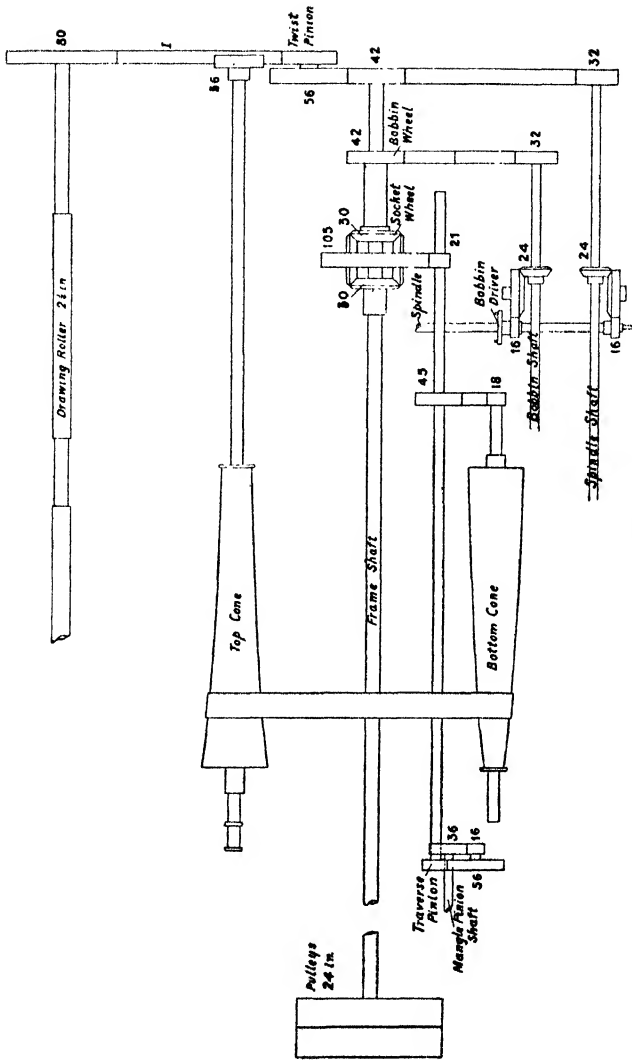

FIG. 61

means of a belt; on the end of the bottom cone shaft an 18 pinion drives a 45 on the short countershaft; while on this countershaft is a 21 which drives the 105 differential wheel. As will be seen from the sketch, the two cones are arranged with the large end of the one opposite the small end of the other; so that, in order to keep the belt always in the same tension, the diameters of the two cones at corresponding positions must always, when added together, amount to the same, in this case $10\frac{1}{2}$ in.

The top cone is driven by the drawing roller at a uniform speed. The belt, at the start of the shift, is at the large end of the top cone, thus driving the bottom cone fast; as the bobbins fill, the belt, with each layer put on, is shifted along the cones by equal distances, the sizes of which are regulated by the movement of an index wheel, thus causing the bottom cone to be driven more and more slowly. This change in speed is, of course, communicated to the differential wheel. The necessary character of the change, large at the start of the shift, and gradually becoming smaller as the bobbins fill, is obtained from the curves of the profiles of the two cones; these curves, comparatively steep at the left side, flatten out towards the right, so that equal changes in the position of the belt to the right have less and less effect.

The changes in the position of the belt are controlled by the index wheel in the manner shown by the sketch in Fig. 62. The index wheel and catches are arranged and work in the same way as previously described, one catch always being in contact with a tooth while the other is at half-tooth, and the two being worked by the movements of the builder. With each traverse of the builder one of the catches is released and the index wheel is moved round half a tooth by the pull on the barrel *B* of the weight on the chain; the carriage,

with the belt forks, being pulled along at the same time by the chain, carries the belt with it along the cones.

As in the frame with the discs and bowl regulating motion, the frame shaft drives the flyers and the bobbins at the same speed if the differential wheel is standing, and the rotation of this wheel causes the difference between the revolutions of the flyer and bobbin which gives the winding-on.

The method of obtaining the builder drive is practically the same as in the machine previously described. The traverse pinion on the countershaft drives, through the double intermediate 56/16, the 36 on the mangle pinion shaft; on the other end of this shaft is the mangle pinion (4 teeth) which drives the mangle wheel (68 tooth spaces); while on the same shaft as the mangle wheel are the pinions gearing with the racks on the backs of the builder brackets.

The sketches and calculations for the drawing portion of this machine are omitted, as they are similar to those for the previous machine. Taking the speed of the main shaft as 240 r.p.m., the drum as 24 in., the diameter of the bobbin at any time as d , T = diameter of the top cone and B = diameter of the bottom cone at the same time, $T + B = 10\frac{1}{2}$ in., and n = the number of spirals of rove per inch of bobbin length, the calculations for the winding on and traverse motions will be as follows—

Frame shaft—

$$240 \times \frac{24}{18} = 320 \text{ r.p.m.}$$

Spindles—

$$320 \times \frac{42}{32} \times \frac{24}{16} = 320 \times \frac{63}{32} = 630 \text{ r.p.m.}$$

Socket wheel—

$$320 \times \frac{30}{30} - \text{differential wheel r.p.m.} \times 2 = \text{r.p.m.}$$

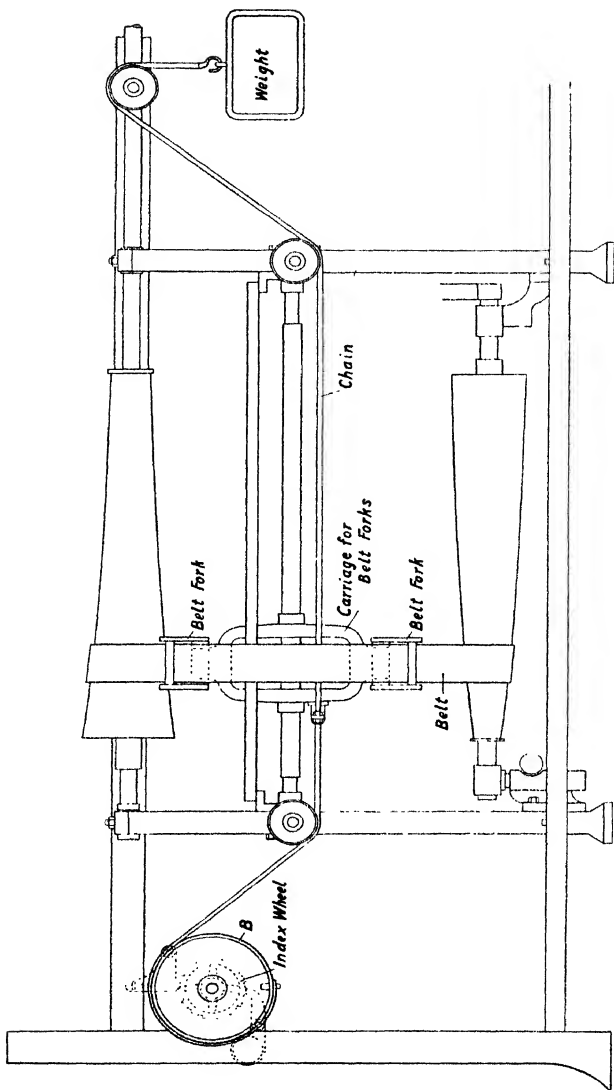

FIG. 62

162 JUTE SPINNING CALCULATIONS

Bobbin drive—

$$\text{Socket r.p.m.} \times \frac{42}{32} \times \frac{24}{16} = \text{socket r.p.m.} \times \frac{63}{32} = \text{r.p.m.}$$

Differential wheel drive—

$$\text{Drawing roller r.p.m.} \times \frac{80}{36} \times \frac{T}{B} \times \frac{18}{45} \times \frac{21}{105} = \text{r.p.m.}$$

Winding-on motion

$$\frac{80}{36} \times \frac{T}{B} \times \frac{18}{45} \times \frac{21}{105} \times \frac{2}{1} \times \frac{42}{32} \times \frac{21}{14} \times \frac{d \times 3.14}{1} = \frac{2\frac{1}{2} \times 3.14}{1}$$

$$\frac{T}{B} = \frac{2\frac{1}{2} \times 3.14 \times 36 \times 45 \times 105 \times 32 \times 14}{80 \times 18 \times 21 \times 2 \times 42 \times 21 \times d \times 3.14} = \frac{45}{14 \times d}$$

Traverse motion—

$$\frac{n \times d \times 3.14}{2\frac{1}{2} \times 3.14} \times \frac{80}{36} \times \frac{T}{B} \times \frac{18}{45} \times \frac{TrP}{56} \times \frac{16}{36} = \frac{68}{10} \times \frac{1}{4}, \text{ or}$$

$$\frac{n \times d}{2\frac{1}{2}} \times \frac{80}{36} \times \frac{45}{14d} \times \frac{18}{45} \times \frac{TrP}{56} \times \frac{16}{36} = \frac{68}{10} \times \frac{1}{4}$$

$$\begin{aligned} \text{Traverse pinion} &= \frac{68 \times 2\frac{1}{2} \times 36 \times 14d \times 45 \times 56 \times 36}{10 \times 4 \times n \times d \times 80 \times 45 \times 18 \times 16} \\ &= \frac{168}{n} \end{aligned}$$

From the above calculations we see that, for the winding on motion and the delivery to balance, $\frac{T}{B}$ must be equal to $\frac{45}{14d}$, or that always

$$\text{Top cone : bottom cone} :: 45 : 14d.$$

From this the diameters of the cones necessary for different sizes of the bobbins may be worked out. E.g. taking the bobbins as $2\frac{1}{2}$ in. diameter, then

$$\frac{T}{B} = \frac{45}{14d} = \frac{45}{14 \times 2\frac{1}{2}} = \frac{45}{35}$$

Now, T and B being corresponding diameters of the cones, the two together must be equal to $10\frac{1}{2}$ in. If,

then, we divide $10\frac{1}{2}$ in. into $45 + 35 = 80$ parts, T will be equal to 45 of these parts and B equal to 35, or

$$T = \frac{10\frac{1}{2}}{80} \times \frac{45}{1} = 5.90625 \text{ in.} \qquad 5.90625$$

$$B = \frac{10\frac{1}{2}}{80} \times \frac{35}{1} = 4.59375 \text{ in.} \qquad 4.59375$$

10.5

The two diameters are fully worked out to show that, when taken together, they amount to $10\frac{1}{2}$ in.

We may now work out and tabulate the sizes of the cones for different sizes of the bobbins during a shift. Taking the empty bobbin as $1\frac{1}{2}$ in. and the increase, with each layer put on, as $\frac{1}{2}$ in., the table would be as follows—

Bobbin diameter (inches)	Top cone (inches)	Decrease (inches)	Bottom cone (inches)	Increase (inches)
$1\frac{1}{2}$	7.16	—	3.34	—
2	6.473	.687	4.027	.687
$2\frac{1}{2}$	5.906	.567	4.593	.566
3	5.431	.475	5.069	.476
$3\frac{1}{2}$	5.026	.405	5.474	.405
4	4.678	.348	5.822	.348
$4\frac{1}{2}$	4.375	.303	6.125	.303
5	4.108	.267	6.392	.267

In this table the gradually lessening decrease in the size of the top cone and increase in that of the bottom cone from the start of the shift to the finish are very noticeable. These correspond to the gradually lessening shifts of the bowl towards the centre in the discs and bowl mechanism. The profiles of the two cones are so shaped as to give these, and taken together, therefore, take the place of the scroll in this mechanism.

Other Methods of Regulating the Winding-on Motion.**(2) The Expansion Pulley**

In Fig. 63 we have the lay-out of the drive from the drawing roller to the differential wheel in a roving frame with an expansion pulley drive. A 15 in. grooved pulley on the drawing roller drives the expansion pulley *AB* by means of a V-sectioned belt; on

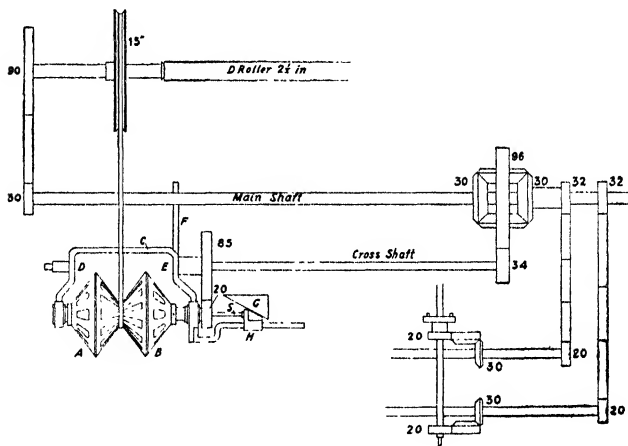

FIG. 63

the same shaft as the pulley is a 20 pinion driving an 85 on the cross shaft; on the cross shaft are a 34 driving the 96 differential wheel and the traverse pinion for driving the mangle wheel shaft (not shown). The necessary variation in the drive is obtained by altering the diameter of the expansion pulley.

The expansion pulley is in two parts, *A* and *B*, each of which is a cone with open slots which allow the two cones to intersect and so form a sort of grooved pulley. The diameter at the bottom of the groove of the pulley will be small when the two cones only

intersect a little, but will increase as the two halves are pushed together. In the machine the expansion pulley shaft is carried by a bracket *C* which swings on the centre *DE*. The weight of the expansion pulley is more than balanced by a heavy weight (not shown) on the arm *F*, so that, if the bracket were free to move, the weight would cause it to swing round its centre *DE*, the pulley coming upwards. When this happens, the bracket *H* and spindle *S* are pushed to the side by the edge of the cam *G*; this spindle is connected to the half *B* of the expansion pulley, so that the half *B* is pushed further in on *A*, causing the diameter of the pulley to become larger. In practice, the pulley starts, with the beginning of the shift, at its lowest position with the half *B* at its full extent to the right, giving a small diameter. With each traverse of the builder, the weight is allowed to drop a distance which is controlled by the movement of the index wheel; the bracket *C* carrying the pulley will move round the centre *DE* to correspond; the half *B* of the pulley being closed in on the half *A* by the action of the cam *G*, the pulley will increase in diameter and be driven more slowly. This, in turn, will drive the differential wheel more slowly, giving the winding on variation required.

Taking the bobbin diameter at any time during the shift as *d* and the corresponding diameter of the expansion pulley as *P*, the calculations for this mechanism are as follows—

Spindles—

$$\begin{aligned} \text{R.p.m. of frame shaft} \times \frac{32}{20} \times \frac{30}{20} &= \text{r.p.m. of frame shaft} \times 2.4 \\ &= \text{r.p.m.} \end{aligned}$$

Socket wheel—

$$\text{Frame shaft r.p.m.} \times \frac{30}{30} - \text{differential wheel r.p.m.} \times 2 = \text{r.p.m.}$$

Bobbin drive—

$$\text{Socket r.p.m.} \times \frac{32}{20} \times \frac{30}{20} = \text{socket r.p.m.} \times 2.4$$

Winding-on motion—

$$\frac{15}{P} \times \frac{20}{85} \times \frac{34}{96} \times \frac{2}{1} \times \frac{32}{20} \times \frac{30}{20} \times \frac{d \times 3.14}{1} = \frac{2\frac{1}{2} \times 3.14}{1}$$

$$P = \frac{15 \times 20 \times 34 \times 2 \times 32 \times 30 \times d \times 3.14}{85 \times 96 \times 20 \times 20 \times 2\frac{1}{2} \times 3.14} = 2.4d$$

We see then from the calculation for the winding on that P must be always equal to $2.4d$ in order that the winding on may balance the delivery, that is, the diameter of the expanding pulley must vary directly as the bobbin diameter. As the bobbin increases by uniform amounts, so also must the pulley. The right half B , therefore, will move in on the other half A by uniform steps, so that the acting edge of the cam G will be straight.

Miscellaneous Problems

Most of the problems with regard to spindle and bobbin speeds, delivery in inches, production, etc., may be readily solved from the following formulae—

Turns per inch	=	$\frac{\text{spindle revolution}}{\text{delivery in inches}}$
Spindle revolutions	=	delivery in inches \times turns per inch
Delivery in inches	=	$\frac{\text{spindle revolutions}}{\text{turns per inch}}$
Winding on revolutions	=	$\frac{\text{delivery in inches}}{\text{circumference of bobbin}}$
Bobbin revolutions	=	flyer (or spindle) revolutions - winding on revolutions

the revolutions and inches delivered being, of course, taken for the same unit of time—the minute. The two following examples will serve to show the application of the formulae.

EXAMPLE 1. A roving frame of 64 spindles has a spindle speed of 720 r.p.m.; twist on rove 0.8 turns per

inch; diameter of drawing roller, $2\frac{1}{4}$ in.; weight of rove, 72 lb. per spindle. It is required to find—

- (a) Delivery in inches per minute;
- (b) Revolutions per minute of the drawing roller;
- (c) Bobbin revolutions per minute when 3 in. diameter;
- (d) Time taken to fill a bobbin holding $2\frac{1}{4}$ lb.;
- (e) Production per week of 48 hours, allowing 25 per cent for stoppages.

(a) Delivery in inches

$$= \frac{\text{spindle revolutions}}{\text{turns per inch}} = \frac{720}{0.8} = 900 \text{ in. per min.}$$

(b) Drawing roller r.p.m.

$$= \frac{\text{delivery in inches}}{\text{circumference of drawing roller}} = \frac{900}{2\frac{1}{4} \times 3.14} = 127.3$$

(c) Winding on revolutions

$$= \frac{\text{delivery in inches}}{\text{circumference of bobbin}} = \frac{900}{3 \times 3.14} = 95.5 \text{ per min.}$$

Bobbin revolutions = spindle revolutions - winding on revolutions
 $= 720 - 95.5 = 624.5 \text{ per minute}$

(d) 72 lb. = 14,400 yards of rove,
 $2\frac{1}{4} \text{ lb.} = \frac{14,400}{72} \times \frac{2\frac{1}{4}}{1} = 450 \text{ yards per bobbin,}$

At 900 in. per min. delivery the time to fill the bobbin will be

$$\frac{450 \times 36}{900} = 18 \text{ minutes.}$$

(e)
$$\frac{720}{0.8} \times \frac{1}{36} \times \frac{1}{14,400} \times \frac{60}{1} \times \frac{48}{1} \times \frac{75}{100} \times \frac{72}{1} \times \frac{1}{112} \times \frac{64}{1} = 154.28$$

In. per min.
Yd. per min.
Sp. per min.
Sp. per hr.
Sp. per week
Sp. per week, allowing 25 per cent off
Lb. per week
Cwt. per week
Total cwt. for whole frame for week, allowing 25 per cent

168 JUTE SPINNING CALCULATIONS

EXAMPLE 2. A roving frame has a drawing roller of $2\frac{1}{2}$ in. diameter running at 120 r.p.m.; twist on rove, 0.85 turns per in.; draft on roving, 9; pitch of screw, $\frac{1}{2}$ in. It is required to find

- (a) Delivery in inches per minute;
- (b) Spindle revolutions per minute;
- (c) Bobbin revolutions per minute when 4 in. diameter;
- (d) Fallers per minute.

(a) Delivery in inches

$$= 120 \times 2\frac{1}{2} \times 3.14 = 942 \text{ per min.}$$

(b) Spindle revolutions

$$\begin{aligned} &= \text{delivery in in.} \times \text{turns per in.} = 942 \times .85 \\ &= 800 \text{ per min.} \end{aligned}$$

(c) Winding on revolutions

$$= \frac{\text{delivery in in.}}{\text{bobbin circumference}} = \frac{120 \times 2\frac{1}{2} \times 3.14}{4 \times 3.14} = 75$$

Bobbin revolutions = spindle revolutions - winding on revolutions

$$= 800 - 75 = 725 \text{ r.p.m.}$$

(d) Retaining roller speed

$$= \frac{\text{drawing roller speed}}{\text{draft}} = \frac{942}{9} = 104.6 \text{ in. per min.}$$

Faller speed = retaining roller speed + faller lead

Taking faller lead at $2\frac{1}{2}$ per cent

$$\begin{aligned} \text{Faller speed} &= \text{retaining roller speed} \times \frac{102\frac{1}{2}}{100} = 104.6 \times \frac{102\frac{1}{2}}{100} \\ &= 107.3 \text{ in. per min.} \end{aligned}$$

$$\text{Fallers per minute} = \frac{\text{faller speed}}{\text{faller pitch}} = \frac{107.3}{\frac{1}{2}} = 107.3 \times 2 = 214.6$$

CHAPTER VII

THE SYSTEM

BEFORE proceeding further it will be necessary to consider the methods of calculating the drafts and doublings on a system to give a certain weight of rove, and also the relative speeds of the different machines so that the material may go evenly forward.

Practical Limitations

There are certain important practical limits which must be taken into account when arranging the drafts, doublings, and speeds on a system, namely—

For good medium work the breaker feed should not be much more than 240 lb. to the 100 yd. For heavy, coarse work as high as 320 lb. to the 100 yd. is used.

The normal ratio of the speed of the feed to that of the cylinder is about $\frac{1}{20}$ th for the breaker, and from $\frac{1}{18}$ th to $\frac{1}{25}$ th for the finisher card. In the case of the breaker card the ratio may have, of course, to be altered to suit different materials. In the case of the finisher card it is often a matter of the number of finishers to each breaker; where there is sufficient breaker power, it is usually better for the material to have a quick, light feed on the finisher than a slow, heavy one.

The draft on the breaker card may be from 8 to 14, 12 being about the average; on the finisher card the draft may be between 10 and 18, 15 and 16 being very commonly used. It is better, however, to arrange for a correct ratio of feed to cylinder than

for a particular draft, the drawing roller being then made to run at the speed necessary to give the quantity required. As mentioned earlier, if the weight of the sliver in pounds per 100 yd. is from $\frac{1}{8}$ th to $\frac{1}{3\frac{1}{2}}$ nd of the pounds delivered per hour, the draft will work out at about the normal.

The drafts on the drawing and roving frames should be—

On the push-bar drawing or roving	between $3\frac{1}{2}$ and 5
On the spiral drawing	between $6\frac{1}{2}$ and 9
On the spiral roving	between 7 and 10
On a rotary drawing or roving	not more than 4

The drafts on the rovings may, of course, be considerably shorter than the above when running on special roves.

The weights of the sliver delivered by the various machines in pounds per 100 yd. should be about as follows—

Breaker card:	15 to 20 lb. for medium, up to 27 lb. for heavy
Finisher card:	11 to 16 lb. for medium, up to 20 lb. for heavy
Push-bar drawing:	12 to 16 lb. for medium, up to 20 lb. for heavy.

The sliver off the finisher drawing should be such as to give a reasonable draft on the roving frame. For finer work the sliver weights would be less in proportion.

The speed of the fallers on a push-bar may be as high as 450 fallers per minute, but should, preferably, be lower. In a spiral, the most economical speed is about 220 fallers per minute, though speeds of 250 and over are not uncommon.

The roving frame spindle speeds are—

For 8 in. \times 4 in.	1200 r.p.m.	} maximum
For 9 in. \times $4\frac{1}{2}$ in.	1000 r.p.m.	
For 10 in. \times 5 in.	800 r.p.m.	

Calculations

We shall take first a system with the following details—

Machines . . .	Breaker and finisher cards, push-bar and spiral drawings, and spiral roving
Breaker dollop . . .	29½ lb.
Clock length . . .	13 yards
Breaker draft . . .	12
Finisher card . . .	Draft, 15; doublings 12 into 1
Push-bar drawings . . .	Doublings, 4 into 1
Spiral drawings . . .	Doublings, 2 into 1.

It is required to find what drafts on the push-bar and spiral drawings and on the roving would give a rove weighing 72 lb. per spangle of 14,400 yd.

Referring to the end of Chapter IV we saw that

$$\frac{\text{dollop} \times 100}{\text{clock length}} \times \frac{1}{\text{breaker draft}} \times \frac{\text{ends of finisher}}{\text{finisher draft}} = \text{lb. per 100 yd. off finisher.}$$

Instead of stopping at the finisher card, the left side of the equation could have been continued with

$$\times \frac{\text{push-bar doublings}}{\text{push-bar draft}} \times \frac{\text{spiral doublings}}{\text{spiral draft}} \times \frac{1}{\text{roving draft}}$$

and the whole would be equal to the weight of sliver off the roving in pounds per 100 yd. The weight of a rove is, however, given in pounds per spangle of 14,400 yd., so that the pounds per 100 yd. must be multiplied by 144. Substituting the values where known and calling the drafts on the push-bar and spiral drawings and on the roving *a*, *b*, and *c* respectively, our equation becomes

$$\frac{29\frac{1}{2}}{13} \times \frac{100}{1} \times \frac{1}{12} \times \frac{12}{15} \times \frac{4}{a} \times \frac{2}{b} \times \frac{1}{c} \times \frac{144}{1} = \frac{72}{1}$$

whence $a \times b \times c = \frac{29\frac{1}{2} \times 100 \times 12 \times 4 \times 2 \times 144}{13 \times 12 \times 15 \times 72} = 240$

or the three drafts multiplied together equal 240. The draft a on the push-bar must be between $3\frac{1}{2}$ and 5; if we make it 4 then

$$\frac{a \times b \times c}{a} = b \times c = \frac{240}{4} = 60$$

The roving draft c , again, must be between 7 and 10: taking it at 8,

$$\frac{b \times c}{c} = b = \frac{60}{8} = 7\frac{1}{2}$$

Substituting 4 for a , $7\frac{1}{2}$ for b , and 8 for c , the details for the system become

$$\frac{29\frac{1}{2}}{13} \times \frac{100}{1} \times \frac{1}{12} \times \frac{12}{15} \times \frac{4}{4} \times \frac{2}{7\frac{1}{2}} \times \frac{1}{8} \times \frac{144}{1} = \frac{72}{1}$$

The details can be worked out in a similar way with any other factors or factor as the unknown quantities.

Let us now suppose that we have a section of a mill containing the following machinery with details—

Machines	Number of deliveries	Faller pitch (inches)	Diameter of drawing roller (inches)	Delivery in cwt. per hr.
4 breaker cards	1	—	4	5 each
6 finisher cards	1	—	4	$3\frac{1}{2}$ "
6 push-bar drawings	2	$7\frac{1}{8}$	$2\frac{1}{2}$	$3\frac{1}{2}$ "
6 spiral drawings	6	$7\frac{1}{4}$	$2\frac{1}{2}$	$3\frac{1}{2}$ "
6 spiral rovings	64	$7\frac{1}{2}$	$2\frac{1}{2}$	$3\frac{1}{2}$ "

The four breakers supply the six finishers and then each finisher supplies its own system consisting of one push-bar drawing, one spiral drawing, and one roving frame. The group, as a whole, is to be arranged to put through 1 ton per hour, allowing for 10 per cent loss due to evaporation of moisture and other causes; each

machine will therefore have to put through the quantity shown in the last column of the table. It is required to find dollop weight, cloth length, drafts and doublings throughout the systems; to work out the weight of sliver per 100 yd. from each machine in the system, the drawing roller revolutions per minute to produce the required quantity, the fallers per minute on the drawings and rovings, and the spindle speed on the rovings.

Taking again 72 lb. as the weight per spangle of the rove to be produced, we may start by assuming the following details, which are all within the practical limits—

Clock length	. 12½ yd.	Push-bar draft	3.6
Breaker draft	. 12	Spiral doublings	2
Ends on finisher	. 12	Spiral draft	. 7½
Finisher draft	. 15	Roving draft	. 8
Push-bar doublings	4	Twist on rove	. 0.8 turns per in.

Then, calling the dollop weight D , we shall have

$$\frac{D}{12\frac{1}{2}} \times \frac{100}{1} \times \frac{1}{12} \times \frac{12}{16} \times \frac{4}{3.6} \times \frac{2}{7.5} \times \frac{1}{8} \times \frac{144}{1} \times \frac{90}{100} = \frac{72}{1}$$

$$\text{whence } D = \frac{72 \times 12\frac{1}{2} \times 12 \times 16 \times 3.6 \times 7.5 \times 8 \times 100}{100 \times 12 \times 4 \times 2 \times 144 \times 90} = 30 \text{ lb.}$$

and the full details will be

$$\frac{30 \times 100}{12\frac{1}{2}} \times \frac{1}{12} \times \frac{12}{16} \times \frac{4}{3.6} \times \frac{2}{7.5} \times \frac{1}{8} \times \frac{144}{1} \times \frac{90}{100} = \frac{72}{1}$$

Working these details out in series, we get

$$\frac{30 \times 100}{12\frac{1}{2}} = 240 \text{ lb. per 100 yd., weight of breaker feed}$$

$$\frac{240}{12} = 20 \text{ lb. per 100 yd., sliver off breaker card}$$

$$20 \times \frac{12}{16} = 15 \text{ lb. per 100 yd., sliver off finisher card}$$

$$15 \times \frac{4}{3.6} = 16\frac{2}{3} \text{ lb. per 100 yd., sliver off push-bar drawing}$$

174 JUTE SPINNING CALCULATIONS

$$\frac{50}{3} \times \frac{2}{7.5} = 4\frac{1}{3} \text{ lb. per 100 yd., sliver off spiral drawing}$$

$$\frac{40}{9} \times \frac{1}{8} = \frac{5}{9} \text{ lb. per 100 yd., sliver off roving frame}$$

$$\frac{5}{9} \times \frac{144}{1} \times \frac{90}{100} = 72 \text{ lb. per spangle, weight of rove}$$

and these weights are all within the practical limits.

We have next to work out the revolutions per minute of the drawing rollers of the different machines in the system. Starting with the breaker card, which has to deliver 5 cwt. per hour, and taking the revolutions per minute of the breaker card drawing roller as R , we shall have the production equation

$$R \times \frac{4 \times 3.14}{12 \times 3} \times \frac{1}{100} \times \frac{20}{1} \times \frac{1}{112} \times \frac{60}{1} = \frac{5}{1}$$

$$R = \frac{5 \times 12 \times 3 \times 100 \times 112}{4 \times 3.14 \times 20 \times 60} = 133 \text{ r.p.m.}$$

but, as 10 per cent of the weight of this production is lost on the way across, we must allow for this in the calculation, so that the required revolutions per minute of the breaker drawing roller will be

$$\frac{133}{1} \times \frac{100}{90} = 148.2$$

which we may simply take as 150 r.p.m.

To find the revolutions per minute for the finisher card drawing roller, we might proceed in the same way as for the breaker card, but the following method is easier. The breaker card drawing roller takes 150 r.p.m. to produce 5 cwt. per hour of a 20 lb. per 100 yd. sliver; from this we can work out what revolutions per minute the finisher card drawing roller, which is the same diameter, must make to produce $3\frac{1}{3}$ cwt. of a sliver lighter to the extent of $\frac{1}{6}$, the effect of the doublings and draft on the finisher. The revolutions

per minute of the finisher card drawing roller evidently will be

$$150 \times \frac{3\frac{1}{2}}{5} \times \frac{16}{12} = 133\frac{1}{2}$$

The revolutions of the push-bar drawing roller may be found in the same way. The finisher card drawing roller, which is 4 in. diameter, must make $\frac{400}{3}$ revolutions per minute to deliver 3.33 cwt. of sliver per hour with one delivery. Compared with this, the push-bar drawing has to deliver the same quantity; its drawing roller is $2\frac{1}{2}$ in. diameter; the sliver delivered is $\frac{4}{3.6}$ times heavier; and there are two deliveries instead of one. The drawing roller must therefore go faster on account of the smaller diameter, slower on account of the heavier sliver, and slower also because of the greater number of deliveries; its revolutions per minute, therefore, will be

$$\frac{400}{3} \times \frac{3.3}{3.3} \times \frac{4}{2\frac{1}{2}} \times \frac{3.6}{4} \times \frac{1}{2} = 96$$

So also with the spiral drawing; compared with the push-bar, the amount to be delivered and the drawing roller diameters are the same, but the sliver delivered is lighter by $\frac{2}{7\frac{1}{2}}$, and there are six deliveries in place of two. The revolutions per minute of the spiral drawing roller, then, will be

$$\frac{96}{1} \times \frac{3.3}{3.3} \times \frac{2\frac{1}{2}}{2\frac{1}{2}} \times \frac{7\frac{1}{2}}{2} \times \frac{2}{6} = 120$$

Finally with the roving. Compared with the spiral drawing, the amount to be delivered is the same; the drawing roller diameter is $2\frac{1}{2}$ in. against $2\frac{1}{2}$ in. on the spiral drawing; the sliver is lighter to the

extent of $\frac{1}{3}$; and there are 64 deliveries instead of 6. The roving frame drawing roller revolutions will be

$$120 \times \frac{3.3}{3.3} \times \frac{2\frac{1}{2}}{2\frac{1}{2}} \times \frac{8}{1} \times \frac{6}{64} = 100$$

To these figures which we have worked out for the different drawing rollers we must add certain allowances for loss of time due to stoppages, etc., say 5 per cent on breaker and finisher cards, 10 per cent on the drawing frames, and 25 per cent on the roving frame. The actual drawing roller revolutions required, therefore, will be

Breaker card	$150 \times \frac{100}{95} = 158$ per min.
Finisher card	$\frac{400}{3} \times \frac{100}{95} = 140$ per min.
Push-bar drawing	$96 \times \frac{100}{90} = 106.6$ per min.
Spiral drawing	$120 \times \frac{100}{90} = 133.3$ per min.
Roving frame	$100 \times \frac{100}{75} = 133.3$ per min.

These figures having been obtained, the necessary drums, cylinder or speed pinions may be worked out from the details of the gearing of the machines.

The faller speeds may now be calculated for the drawings and rovings in order to see whether they are within the practical limits or not.

PUSH-BAR DRAWING. The revolutions per minute of the drawing roller being 106.6, the surface speed will be

$$106.6 \times 2\frac{1}{2} \times 3.14 \text{ in. per min.}$$

The retaining roller surface speed will be obtained by dividing this by the draft on the machine

$$106.6 \times 2\frac{1}{2} \times 3.14 \times \frac{1}{3.6} \text{ in. per min.}$$

Allowing for an 8 per cent lead, the faller speed will be

$$106.6 \times 2\frac{1}{2} \times 3.14 \times \frac{1}{3.6} \times \frac{108}{100} \text{ in. per min.}$$

and dividing this by the pitch of the fallers, we get

$$106.6 \times 2\frac{1}{2} \times 3.14 \times \frac{1}{3.6} \times \frac{108}{100} \times \frac{8}{7} = 288 \text{ fallers per minute.}$$

SPIRAL DRAWING

$$133.3 \times 2\frac{1}{2} \times 3.14 \times \frac{1}{7.5} \times \frac{102}{100} \times \frac{7}{4} = 250 \text{ fallers per minute}$$

Drawing roller surface speed

Retaining roller surface speed

Faller surface speed

Fallers per minute

ROVING FRAME

$$133.3 \times 2\frac{1}{2} \times 3.14 \times \frac{1}{8} \times \frac{102}{100} \times \frac{2}{1} = 240 \text{ fallers per minute.}$$

The speed of the spindles on the roving frame, with the twist on the rove at 0.8 turns per inch, will be

$$133.3 \times 2\frac{1}{2} \times 3.14 \times 0.8 = 753.6 \text{ r.p.m.}$$

With the above details on the systems the correct production should be obtained; no machine should be overloaded or overdriven; and the material should go steadily forward with no delay anywhere.

Examples of Working Details from Actual Practice

	Br.	F.	Sp.	Sp.	R.		
(1)	$\frac{24 \times 100}{12.5}$	$\times \frac{1}{12}$	$\times \frac{12}{15}$	$\times \frac{6}{7.5}$	$\times \frac{6}{8}$	$\times \frac{3}{8} \times \frac{1}{8}$	= for 48 lb. rove.

	Br.	F.	P-b.	Sp.	R.		
(2)	$\frac{22 \times 100}{13}$	$= \frac{1}{10}$	$\times \frac{10}{14}$	$\times \frac{4}{3.5}$	$\times \frac{2}{7.5}$	$\times \frac{1}{8}$	for 66 lb.

$$(3) \frac{33 \times 100}{13 \cdot 13} \times \frac{\text{Br.}}{13 \cdot 5} \times \frac{\text{F.}}{13 \cdot 5} \times \frac{\text{P-b.}}{3 \cdot 6} \times \frac{\text{Sp.}}{7 \cdot 2} \times \frac{\text{R.}}{8 \cdot 4} \text{ for 72 lb.}$$

$$(4) \frac{33 \times 100}{13 \cdot 13} \times \frac{\text{Br.}}{13 \cdot 5} \times \frac{\text{F.}}{12 \cdot 5} \times \frac{\text{P-b.}}{4} \times \frac{\text{Sp.}}{8} \times \frac{\text{P-b.R.}}{5} \text{ for 105 lb.}$$

$$(5) \frac{28 \times 100}{12} \times \frac{\text{Br.}}{13} \times \frac{\text{F.}}{16} \times \frac{\text{P-b.}}{3 \cdot 5} \times \frac{\text{P-b.}}{4\frac{1}{4}} \times \frac{\text{R.}}{7} \text{ for 126 lb.}$$

$$(6) \frac{32 \times 100}{10} \times \frac{\text{Br.}}{12} \times \frac{\text{F.}}{13} \times \frac{\text{P-b.}}{4} \times \frac{\text{P-b.}}{4} \times \frac{\text{P-b.R.}}{5 \cdot 5} \text{ for 240 lb.}$$

Br. = Breaker card

F. = Finisher card

P-b. = Push-bar drawing

Sp. = Spiral drawing

R. = Spiral roving frame

P-b. R. = Push-bar roving frame

CHAPTER VIII

THE SPINNING FRAME

ON the spinning frame the rove is drawn out to the final size, twisted to the degree required by the purpose for which the yarn is intended, and then wound on to a bobbin.

Operations on the Machine

The sketch, Fig. 64, gives the main lines of a spinning frame. The rove bobbins are placed on the *creel* at the top of the machine; from this the rove passes down through the *rove guide* to the retaining rollers. These rollers are fluted to enable them to keep a firm grip of the rove and so to pass it on at a uniform speed. The rove passes over the *breast-plate* and is guided in between the drawing roller and the pressing roller by the small tin *conductor*. When passing from the retaining rollers to the drawing rollers, the rove is drawn out to the required extent by the faster moving drawing rollers. In this operation the breast-plate plays a most important part; its function is to keep the twist on the rove as long as necessary and only to allow it to untwist to the extent necessary for the rove to be drawn out evenly. This is done by adjusting the breast-plate so that the rove bears on it either lightly or firmly as the conditions require.

The drawn out rove passes down from the drawing rollers to the *flyer* and is twisted by the revolutions of the flyer; to prevent the thread from "ballooning" or flying outwards during this operation, it is made to bear slightly on the back of the eye in the threadplate once during each revolution of the spindle. The thread

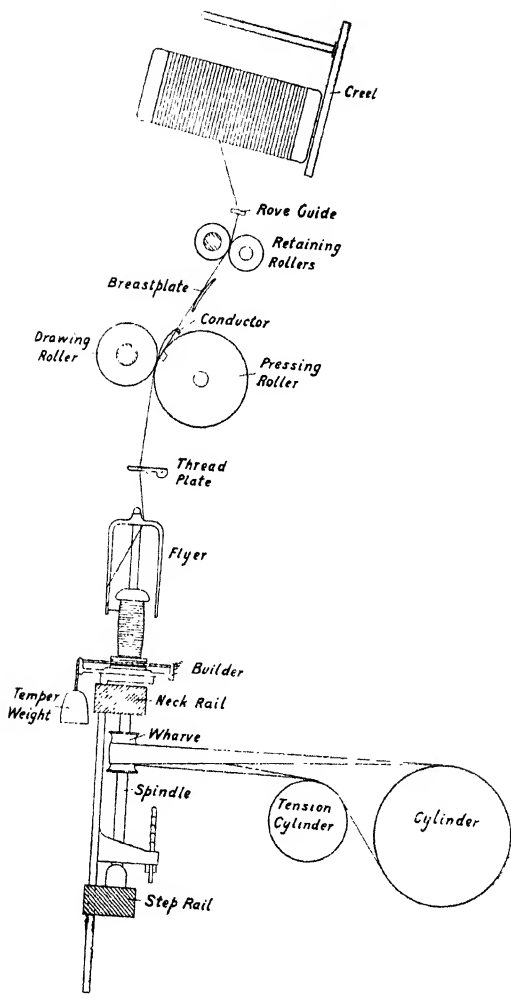

FIG. 64

passes down by means of the flyer on to the bobbin, the winding-on motion being obtained by the dragging action of the *temper weight* and cord on the bobbin. The builder moving at an almost uniform rate up and down builds the thread on the bobbin.

Gearing

Fig. 65 shows a typical gearing for a spinning frame. The drive to the machine is received by the 14 in. pulleys which are on the end of the cylinder arbor; the other drives are as shown. The spindles are driven from the cylinder by means of bands acting on the spindle *wharves*. On the end of the cylinder arbor, just inside the pulleys, a 30 cylinder pinion drives, through a 160 intermediate and a double intermediate 80/*TP*, the 120 wheel on the end of the drawing roller. On the other end of the drawing roller the draft pinion *DP2* drives, through the double intermediate 70/*DP1*, the 80 wheel on the end of the retaining roller. Further, an 11 pinion on the retaining roller drives the 128 wheel on the same shaft as the heart cam which, through a lever and connections, drives the builder.

Calculations

Taking the speed of the main shaft as 200 r.p.m. and the drum as 32 in. diameter, the calculations for the speeds and speed ratios are as follows—

$$\text{Cylinder:} \quad 200 \times \frac{32}{14} = 457 \text{ r.p.m.}$$

$$\text{Spindles:} \quad 200 \times \frac{32}{14} \times \frac{10}{1.625} = 2813 \text{ r.p.m.}$$

$$\begin{aligned} \text{Drawing roller:} \quad & 200 \times \frac{32}{14} \times \frac{30}{80} \times \frac{TP}{120} = \text{r.p.m.} \\ & 200 \times \frac{32}{14} \times \frac{30}{80} \times \frac{TP}{120} \times 4 \times 3.14 \\ & = \text{surface speed in in.} \end{aligned}$$

$$\begin{aligned} \text{Draft: } & \frac{80}{DP1} \times \frac{70}{DP2} \times \frac{4 \times 3.14}{2.5 \times 3.5} = \frac{8042.5}{DP1 \times DP2} \\ & = \text{draft, } 8042.5 \text{ being constant.} \end{aligned}$$

In this calculation the retaining roller circumference has been taken as diameter $\times 3.5$ —instead of $\times 3.14$ —to allow for the fluting of the roller.

$$\begin{aligned} \text{Twist: } & \frac{120}{TP} \times \frac{80}{30} \times \frac{10}{1.625} \times \frac{1}{4 \times 3.14} = \frac{156.7}{TP} \\ & = \text{turns per in, } 156.7 \text{ being constant.} \end{aligned}$$

In the foregoing calculations the draft has been found in the usual way, by dividing the surface speed of the drawing roller, with the retaining roller running at one revolution per minute, by the corresponding speed of the retaining roller; and the twist, by dividing the revolutions of the spindles for one revolution of the drawing roller by the corresponding delivery of the drawing roller in inches.

Draft

In the draft calculation we have found that

$$\frac{8042.5}{DP1 \times DP2} = \text{draft, or } \frac{8042.5}{\text{draft}} = DP1 \times DP2$$

or any two wheels will, if used, give a certain draft if the numbers of their teeth, when multiplied together,

give a result equal to $\frac{8042}{\text{required draft}}$. If, for example,

a draft of 8 were wanted; $\frac{8042}{\text{draft}} = \frac{8042}{8} = 1005$;

$25 \times 40 (= 1000)$ gives this result very nearly, so that, if we make $DP1 = 25$ and $DP2 = 40$, we should get the required draft of 8.

We have taken both $DP1$ and $DP2$ as change pinions. Very often, however, one only is used as the change pinion, the other being kept unchanged. In this case,

if we divide the constant 8042 by the number of teeth in the wheel kept unchanged, we shall get the draft

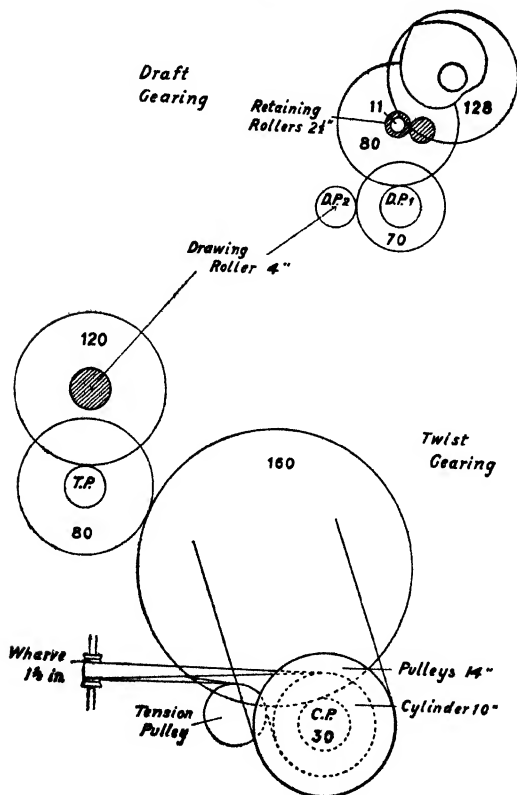

FIG. 65

constant for so long as it is kept so. It is well to keep in mind, however, that both wheels may be used as change pinions if required. Suppose, for example, that

in the gearing under discussion $DP1$ were 30, that we wished to have a draft of 5, and that we had no change pinion larger than 45. With $DP1 = 30$

$$\text{draft constant} = \frac{8042 \cdot 5}{30} = 268$$

for a draft of 5 $DP2$ would require to be $\frac{268}{5} = 54$, a pinion of which size is not available. If, however, we take the double constant, 8042, and divide it by the required draft, thus,

$$\frac{8042}{5} = 1608.4$$

then 40 and 40 which, when multiplied together, give this result very nearly, would be the numbers of the teeth in the change pinions, $DP1$ and $DP2$, to give the draft required.

The draft to give a certain size of yarn from a given rove is found by dividing the weight of the rove by the weight of the yarn, both being in pounds per spangle. This must be modified to a slight extent. Owing to the spiral position which the fibres are made to take up when twisted into a yarn, the yarn is shorter than the untwisted drawn out rove. On an average, 100 yd. of the sliver, as it comes from the drawing rollers, make only 96 yd. when twisted into yarn. The yarn is therefore proportionally heavier for a given length than the drawn-out sliver, and this must be allowed for when calculating the draft for a certain size of yarn. The draft found by dividing the weight of the rove by the weight of the yarn must be multiplied by $\frac{100}{96}$, to allow for the contraction due to the twisting and the consequent increase in weight per unit of length.

Twist Constants

On page 153 we saw that on yarns, or roves, with the same degree of twist the turns per inch on the different

sizes are inversely proportional to the square roots of their weights per spangle; from this it follows that for each size the turns per inch $\times \sqrt{(\text{spangle weight})} =$ a constant. Taking, for example, 4 lb. yarn with a twist of 7.5 turns per inch as a basis, the turns per inch on $6\frac{1}{4}$ lb., 9 lb., $11\frac{1}{4}$ lb., 16 lb., etc., yarns with the same degree of twist, would be—

$$\text{For } 6\frac{1}{4} \text{ lb.} \quad . \quad . \quad . \quad 7.5 \times \frac{\sqrt{4}}{\sqrt{6\frac{1}{4}}} = \frac{7.5 \times 2}{\sqrt{6\frac{1}{4}}} = \frac{15}{2.5} = 6$$

$$\text{For 9 lb.} \quad . \quad . \quad . \quad 7.5 \times \frac{\sqrt{4}}{\sqrt{9}} = \frac{7.5 \times 2}{\sqrt{9}} = \frac{15}{3} = 5$$

$$\text{For } 11\frac{1}{4} \text{ lb.} \quad . \quad . \quad . \quad 7.5 \times \frac{\sqrt{4}}{\sqrt{11\frac{1}{4}}} = \frac{7.5 \times 2}{\sqrt{11\frac{1}{4}}} = \frac{15}{3.5} = 4.28$$

and so on. In every case the turns per inch work out to

15

$\frac{15}{\sqrt{(\text{spangle weight})}}$, and the turns per inch $\times \sqrt{(\text{spangle weight})}$ will be equal to 15. This number may therefore be taken as the constant for the degree of twist equivalent to 7.5 turns per inch on a 4 lb. yarn. In a similar way the constant may be found for any degree of twist if the number of turns and the spangle weight of any size of yarn with that degree of twist are known.

Yarns are used for many different purposes and each different purpose necessitates a definite degree of twist on the yarn. For each degree of twist required for the different purposes the turns per inch necessary for certain sizes of yarns have been found by practical experience and from them the corresponding constants have been worked out. They are as follows—

For heavy weft	8
„ light weft	10
„ starching warp	12
„ hard warp	14 to 16
„ rope yarns	18

The strongest yarn from jute material is obtained by using a constant of about 12.8.

The twist on any yarn, then, may be represented by the formula $\frac{K}{\sqrt{W}}$ where K is the constant for the degree of twist required by the purpose to which the yarn is to be put, and W is the weight of the yarn in pounds per spangle. The number of turns per inch on the yarn being found by this means, it only remains to divide the twist constant for the frame on which the yarn is to be spun by this number in order to obtain the twist pinion.

Spindle Speeds

The table given below gives the approximate speeds for spinning frame spindles of different pitches, also the sizes of bobbins and appropriate sizes of yarns, for the ordinary type of frame.

Pitch of Spindles (inches)	Bobbin Traverse (inches)	Revolutions per minute of Spindles	Sizes of Yarns (pounds)
3	3	3200	3- 5 warp
3 $\frac{1}{4}$	3 $\frac{1}{4}$	3100	4- 7 "
3 $\frac{1}{2}$	3 $\frac{1}{2}$	3000	5-10 "
3 $\frac{3}{4}$	3 $\frac{3}{4}$	2900	6-12 "
4	4	2800	7-14 "
4 $\frac{1}{2}$	4 $\frac{1}{2}$	2500	10-20 weft
5	5	2200	12-24 "
5	6	2000	15-30 "
6	6	1800	24-48 "

In the above table the speeds given for the spindles from 3 in. up to 4 in. are for warp yarns; for the corresponding weft yarns the speeds would be approximately 200 revolutions per minute less.

Frame Adjustment

We can now arrange the spinning frame of which we have the gearing given in Fig. 65 to spin a certain size

of yarn. For example, it may be required to set the frame to spin 8 lb. warp yarn from 72 lb. rove. We shall take it that the frame has a 4 in. pitch of spindle, and that the speed of the main shaft is 200 r.p.m.; the other details will be worked out as follows.

SPINDLE SPEED. From the table of spindle speeds we find that the speed for spindles of 4 in. pitch should be about 2800 r.p.m. Taking D as the drum, we have

$$\frac{200}{1} \times \frac{D}{14} \times \frac{10}{1\frac{1}{2}} = \frac{2800}{1}$$

$$D = \frac{2800 \times 14 \times 1\frac{1}{2}}{200 \times 10} = 31.8, \text{ say } 32 \text{ in.}$$

DRAFT. We shall take $DP1$ as 30, when, as we saw on page 184, the draft constant will be $\frac{80 \cdot 4^2}{30} = 268$ while this 30 is on.

$$\text{Draft} = \frac{72}{8} \times \frac{100}{96} = 9.375$$

$$DP2 = \frac{\text{constant}}{\text{draft}} = \frac{268}{9.375} = 28.6, \text{ say } 29$$

TWIST. The yarn is to be given a warp twist; for this we shall use the constant 15, so that

$$\text{Turns per in.} = \frac{K}{\sqrt{W}} = \frac{15}{\sqrt{8}} = \frac{15}{2.83} = 5.3$$

$$TP = \frac{\text{constant}}{\text{turns per in.}} = \frac{156.7}{5.3} = 30$$

The other adjustments are mechanical, namely, the setting of the breast-plate to make the rove draw out evenly, and of the builder to lay the yarn accurately on the bobbin.

Changing Sizes

We have seen on page 182 that

$$\text{Draft pinion} = \frac{\text{draft constant}}{\text{draft}}, \text{ and twist pinion} = \frac{\text{twist constant}}{\text{turns per in.}}$$

From these it will be readily seen that :

A longer draft requires a smaller draft pinion, and a shorter draft a larger draft pinion.

More turns per inch will require a smaller twist pinion, and less turns per inch a larger twist pinion.

As the draft and twist gearings of most spinning frames are similar to those of the example given in Fig. 65, these statements may be applied to practically all spinning frames.

Let us suppose now that the spinning frame which we set to spin 8 lb. warp yarn from 72 lb. rove has to be changed to spin 12 lb. warp yarn from the same rove. The pinions for the 8 lb. warp were: draft, 29, and twist, 30.

To give 12 lb. yarn instead of 8 lb. from the same rove, the draft must evidently be proportionally shorter, and the draft pinion correspondingly larger

$$29 \times \frac{12}{8} = 43.5 \text{ (say 44)} = \text{draft pinion for 12 lb. yarn.}$$

Both yarns are for warp and will have the same degree of twist. The turns per inch, therefore, on the 12 lb. yarn will be less than those on the 8 lb. yarn proportionally to the square roots of the weights, and the twist pinion will be larger in the same proportion

$$31 \times \frac{\sqrt{12}}{\sqrt{8}} = 31 \times \frac{3.46}{2.83} = 38 = \text{twist pinion for 12 lb. yarn.}$$

Suppose, however, that we had to change the spinning frame running on 8 lb. warp from a 72 lb. rove to 12 lb. weft from a 90 lb. rove. In this case we first find the drafts necessary for the two yarns

$$\text{Draft for 8 lb.} = \frac{72}{8} = 9; \text{ draft for 12 lb.} = \frac{90}{12} = 7\frac{1}{2}.$$

As we are only concerned with the proportional drafts, the contraction due to twist may be ignored—the

draft pinion for the draft of $7\frac{1}{2}$ will be proportionally larger than that for the draft of 12, so that

$$\text{Draft pinion for 12 lb. weft} = \frac{29}{1} \times \frac{9}{7\frac{1}{2}} = 35$$

The one yarn being hard warp, and the other light weft, they must have different degrees of twist, so that we cannot calculate the twist pinions for the change by the use of the square roots of the weights. We must first find the necessary turns per inch on the two yarns by using the K constants for the twists and then take these for the calculation. For hard warp the K constant is 14 to 16—we shall take 15; for light weft the K constant is 10; then

$$\text{Turns per inch for the 8 lb. yarn} = \frac{15}{\sqrt{8}} = \frac{15}{2.83} = 5.3,$$

$$\text{Turns per inch for the 12 lb. yarn} = \frac{10}{\sqrt{12}} = \frac{10}{3.46} = 2.89.$$

The fewer turns per inch on the 12 lb. yarn will require a proportionally larger twist pinion, so that

$$\text{Twist pinion for 12 lb. weft} = 30 \times \frac{5.3}{2.89} = 55 \text{ (very nearly).}$$

With a change such as this, an important matter affecting the setting of the breast-plate must be considered. A 55 pinion for the twist in place of a 30 will drive the drawing roller proportionally faster. A 33 draft pinion instead of a 29 will drive the retaining roller proportionally faster relatively to the drawing roller. The whole effect of the change on the speed of the retaining roller will be to make it run

$$\frac{55}{30} \times \frac{33}{29} = 2.1 \text{ times faster}$$

so that the rove will run down the breast-plate 2.1 times faster and will have so much the less time to

per cent for stoppages, waste, and contraction due to twist.

$$\frac{1600}{1.87} \times \frac{85}{100} \times \frac{1}{36} \times \frac{60}{1} \times \frac{1}{300} \times \frac{1}{48} \times \frac{30}{1} \times \frac{48}{1} \times \frac{1}{112} \times \frac{64}{1} = 69.2 \text{ cwt.}$$

All per spindle

- In. per min.
- Yd. per min.
- Yd. per hr.
- Cuts per hr.
- Spangles per hr.
- Lb. per hr.
- Lb. per week of 48 hr.
- Cwt. per week

Net production for week of 48 hours for whole frame ...

Winding On

The winding-on revolutions and actual revolutions of the bobbins are worked out in exactly the same way as in the case of the roving frame—

$$\text{Winding on revolutions} = \frac{\text{delivery in in.}}{\text{bobbin circumference}}$$

$$\text{Bobbin revolutions} = \text{flyer revolutions} - \text{winding on revolutions.}$$

In the first example of the preceding paragraph the winding-on revolutions, when the bobbin is 2 in. diameter, would be

$$\frac{54 \times 4 \times 3.14}{2 \times 3.14} = 108 \text{ r.p.m.}$$

and the actual bobbin revolutions with spindle speed of 3000 r.p.m. would be

$$3000 - 108 = 2892 \text{ r.p.m.}$$

Builder Traverse Motion

The mechanism for giving the traverse motion to the builder is shown in the sketch, Fig. 66. A *heart*

motion, consisting of the heart-shaped cam *E* and the wheel of 128 teeth on the same arbor, is carried on a bracket fixed on the frame gable and driven by a pinion of 11 teeth on the end of the retaining roller—see Fig. 65. The circumference of the cam is of such a shape that the bowl *C* on the lever *AB* is driven up and down by it at a uniform rate, the length of the travel being equal to the difference between the longest and shortest radii of the cam.

The lever *AB* is hinged at *A*; the outer end *B* will therefore move up and down a distance greater than that of the bowl *C* proportionally to their distances from the hinge. A connecting rod *GG* is attached to the stud *F* near the end *B* of the lever; to the end of this connecting rod is fastened a chain, the other end of which is fixed to the circumference of the pulley *H* in such a way as to leave part of the chain on the pulley circumference. By means of this chain the up and down motion of the rod *GG* is turned into a back and forward motion of the pulley *H*, and this being keyed to the builder shaft the latter will rotate back and forward to correspond. Lastly, this motion of the builder shaft is turned into an up and down motion of the builder by means of the pulleys *K* and the chains connecting them and the builder bracket.

The up and down movement of the stud *F* at the outside end of the lever, to which the connecting rod *GG* is attached, will be proportional to the distance of *F* from the hinge *A* and inversely proportional to the distance from *A* of the stud carrying the bowl *C*. The amount of the back and forward motion of the pulley *H*, from the same up and down motion of the connecting rod *GG*, will be greater proportionally as the pulley *H* is smaller; while the up and down motion of the builder will be proportional to the size of the pulleys *K*. The extent of the movement of the

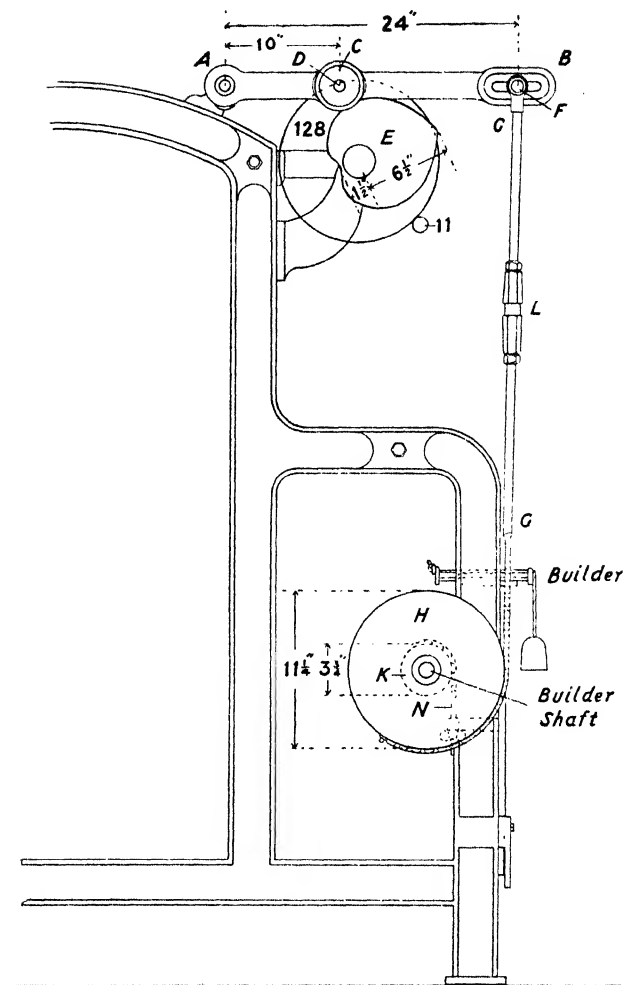

FIG. 66

builder, therefore, taking the sizes as given in the sketch, will be as follows—

Longest radius of the heart cam . . .	6½ in.
Shortest " " " " " . . .	1½ in.
Movement of bowl <i>C</i>	5 in.

$$\begin{aligned} \text{Then} \quad 5 \times \frac{AF}{AD} \times \frac{\text{pulley } K}{\text{pulley } H} &= 5 \times \frac{24}{10} \times \frac{3.75}{11.25} = 4 \text{ in.} \\ &= \text{builder traverse} \end{aligned}$$

The alteration of the length of the traverse for different sizes of bobbin may be effected by shifting the positions of either of the pins *F* and *D* or of both—*F* further out and *D* further in to lengthen the traverse, or *F* further in and *D* further out to shorten it. The change in the position of either when changing to a different size of bobbin may be calculated by simple proportion. Often, however, when frames have to be run, sometimes on one and sometimes on another of two sizes of bobbin, it is handier to have two sizes of pulleys for *H* on the end of the builder shaft, one for each length of traverse. In the sketch, Fig. 66, we have seen that we get a builder traverse of 4 in. when *H* is 11½ in.; if the frames had to be changed frequently to a 4½ in. traverse, we could use pulleys of

$$\frac{11\frac{1}{2} \times 4}{4\frac{1}{2}} = 10 \text{ in.}$$

for the 4½ in. traverse.

In addition to the methods for adjusting the length of traverse on the builder motion, there are two for adjusting the position of the builder. The connecting rod *GG*, Fig. 66, is in two parts, which are joined by a long sleeve or nut *L*; this nut is screwed right handed at one end and left handed at the other, the ends of the two parts of the connecting rod being screwed to correspond. By turning the sleeve *L* one way or the

other, the connecting rod *as a whole* may be lengthened or shortened, thus lifting the whole builder, or lowering it as required. The builder is in short lengths, or sections; any one of these sections may be adjusted for height by means of the thumbscrews on the ends of the chains attached to the pulleys *K*.

Proportion of Roving Spindles to Spinning Spindles

The number of spinning spindles which may be kept going by each roving spindle may be calculated from the relative productions of the two machines. This may be best explained by working out an example, as follows—

A set of roving frames making 72 lb. rove has a spindle speed of 680 r.p.m.; the twist on the rove is 0.8 turns per inch, and the frame efficiency is 75 per cent.

The spinning frames supplied with rove by these roving frames are running on 8 lb. warp; the spindle speed is 3000 r.p.m.; the twist on the yarn 5 turns per inch; and the frame efficiency is 85 per cent.

It is required to find how many spinning spindles one roving spindle will keep going.

The rove being 72 lb. and the yarn 8 lb., the spinning draft will be $\frac{72}{8} = 9$, so that a given length of rove will be turned into yarn nine times that length. Then

$$\frac{680}{0.8} \times \frac{75}{100} = \text{inches delivered by roving per minute per spindle}$$

$$(a) \quad \frac{680}{0.8} \times \frac{75}{100} \times \frac{9}{1} = \text{equivalent in yarn in in.}$$

$$(b) \quad \frac{3000}{5} \times \frac{85}{100} = \text{inches delivered by spinning frame per minute per spindle}$$

Dividing (a) by (b)

$$\frac{680}{0.8} \times \frac{75}{100} \times \frac{9}{1} \times \frac{5}{3000} \times \frac{100}{85} = 11.25$$

or, one roving spindle will keep going $11\frac{1}{4}$ spinning spindles under the given conditions.

CHAPTER IX

REELING

THE yarn after being spun may be made up in different ways. Both warp and weft yarns may be reeled, but warp yarns are often made into *spools* and sometimes into *chains*, while weft yarns are nearly always made into *cops*. So far as calculations are concerned, the only method that requires to be considered is reeling.

Reeling

Reeling consists essentially of winding the yarn on the circumference of a reel of definite size into skeins or hanks of a definite continuous length. These hanks are easy to handle, may be made into compact bundles, and can be easily rewound when required.

The bobbins of yarn to be reeled are placed on vertical—sometimes horizontal—spindles on the top of the machine, usually 24 to each side of the machine. The yarn is wound off by the rotation of a long horizontal frame called a *swift* and measuring 90 in. in circumference, each yarn being made to wind evenly on to the swift by a thread guide in front of the bobbin (see Fig. 67). The yarn reeled from each spindle is made into a hank of as great a length as is possible on the machine, but, to prevent ravelling, each successive 120 threads—called a *cut*—is kept separate by means of an interlacing cord or thick thread called the *leasing*. The one end of the hank is hitched round the first cut, while the other is tied in with the knot made on the two ends of the leasing. They are thus easily found when required for rewinding.

The reeling of each 120 threads is indicated by the

ringing of a bell worked from the swift. On the barrel of the swift, near one end, is a screw gearing with a worm wheel carried by a bracket on the gable. This worm wheel has 124 teeth, so that the swift makes 124 revolutions while the worm wheel makes one. On one of the arms of the worm wheel is fixed a pin

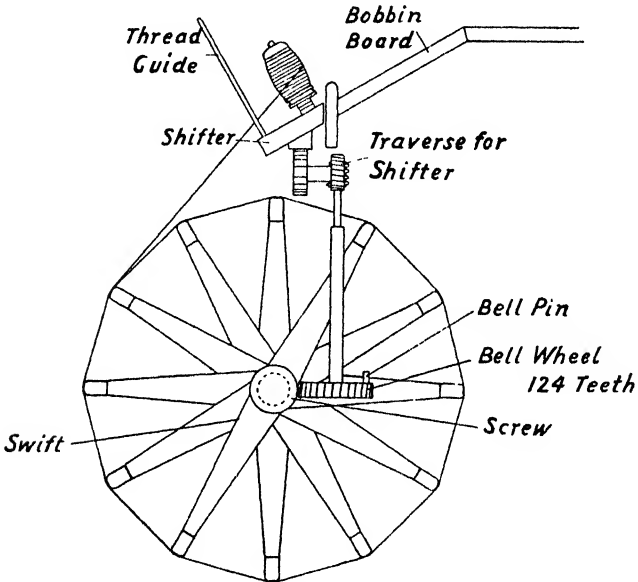

FIG. 67

which, during the rotation of the wheel, pushes back a spring carrying a bell and then suddenly releases it, the bell thus being rung once for each revolution of the worm wheel or 124 revolutions of the swift. Theoretically, the worm wheel should have only 120 teeth, but during the reeling bobbins will run out, ends may break suddenly, and it is not always possible for the

worker to catch them in time. To allow for this, the worm wheel is usually made 124 teeth instead of 120, and it is found in practice that with this allowance and with ordinary carefulness, the yarn may be reeled fairly accurately and at a good practical speed.

Yarn Counts. The Scottish Yarn Table

The following is the "yarn table" used in the trade in Scotland—

90 inches	= 1 thread	=	2½ yards.
120 threads	= 1 cut	=	300 yards.
12 cuts	= 1 hank	=	3,600 yards.
4 hanks	= 1 spangle	=	14,400 yards.

This table gives a very good idea of the principle underlying the reeling operation. The weight of the spangle of 14,400 yd. in pounds is the *weight* of the yarn; it is often called also the *size* and the *grist*; it should not be called the number. When a yarn, then, or rove is said to be 8 lb., 10 lb., 72 lb., etc., it means that 14,400 yd. of the yarn or rove will weigh 8 lb., 10 lb., etc. It should be noted that the standard hank has 12 cuts; as there is very seldom room on the reel to make hanks of 12 cuts, the hanks made may consist of 6, 4, 3, or 2 cuts only; these should be called *mill hanks* to distinguish them from the standard hank.

The Lea Count

The form of Yarn Table which is principally used outside Scotland is as follows—

90 inches	= 1 thread	=	2½ yards.
120 threads	= 1 lea or cut	=	300 yards.
200 cuts	= 1 bundle	=	60,000 yards.

In this system the number of leas or cuts of a yarn which it takes to weigh 1 lb. is the count; it is also called the *lea*, *lea number*, or *number*. When yarns then, are designated 30 lea, 20 lea, etc., or 30's, 40's,

etc., it simply means that 30, 40, etc., cuts or leas of these yarns are required to weigh 1 lb.

It will be noted that, in the Scottish count, the yarn is heavier as the count is higher; while in the lea count the yarn is lighter as the count is higher. The relationship between the two systems may be shown thus: Taking a yarn as weighing W lb. per spangle, then

1 spangle weighs	.	.	W lb.
48 cuts weigh	.	.	W lb.
$\frac{48}{W}$ cuts weigh	.	.	1 lb.

that is,

$$\text{Lea number} = \frac{48}{W} = \frac{48}{\text{pounds per spangle}}$$

$$\text{Lea number} \times \text{lb. per spangle} = 48$$

$$\text{Pounds per spangle} = \frac{48}{\text{lea number.}}$$

Short Tell

It is very necessary that reeling should be done accurately. A deficiency in the number of threads in a hank, or *short tell* as it is called, is a not infrequent fault in reeling and may have serious consequences if it is present to any great extent, especially if the yarn is at the same time apparently the correct weight. For example, we may have a yarn which weighs apparently 8 lb. per spangle, but when the threads are counted, it is found that the hanks have, on an average, only 1416 threads instead of 1440 as they ought to have. The actual weight of the yarn may be found as follows—

1 hank will weigh $\frac{8}{2} = 2$ lb.

Each hank of the yarn will measure $1416 \times 2\frac{1}{2}$ yards.

1 yard will weigh $\frac{2}{1416 \times 2\frac{1}{2}}$ lb.

1 spangle will weigh $\frac{2}{1416 \times 2\frac{1}{2}} \times 14,400 = 8.136$ lb.

The following is a rather shorter method; the yarn has only 1416 threads per hank instead of 1440, but these 1416 threads have the weight the 1440 threads ought to have so that they will be proportionally heavier for a given length. The actual spangle weight will therefore be

$$8 \times \frac{1440}{1416} = 8.136 \text{ lb.}$$

Another example: A bundle of 8 lb. jute which should contain 7 spangles weighs 56 lb.; but it is found that each cut is 12 threads short on an average and that each thread is $90\frac{1}{2}$ in. long. What is the actual spangle weight of the yarn?

The apparent weight of the yarn = $\frac{56}{7} = 8$ lb. per spl.

Each hank has $1440 - 12 = 1428$ threads instead of 1440.

Each thread is $90\frac{1}{2}$ in. instead of 90 in.

The actual weight of the yarn will, therefore, be

$$8 \times \frac{1440}{1428} \times \frac{90}{90\frac{1}{2}} = 8.022 \text{ lb. per spangle.}$$

Checking the Count or Size

When yarns are made into cops or spools, it is not possible to check the count by weighing, as in the case of reeling, the reason being that neither cops or spools are made to an accurate length. It is usual in this case to reel at regular periods, when the yarn is being made, a small definite quantity of the yarn as it comes from the spinning and to weigh this. In practice, the quantity reeled is 3 cuts, the weight of which in ounces is the same as the weight per spangle, as the following will show—

If 3 cuts weigh n ounces, then 1 spangle will weigh

$$\frac{n}{3} \times \frac{48}{1} = 16 \times n \text{ oz.} = n \text{ lb.}$$

This method may also be used to check the spangle weight of a delivery of cops or spools, but it is better for the sake of accuracy, to reel a larger quantity than 3 cuts, and when testing spools the quantity reeled should not be all from one spool.

CHAPTER X

TWISTING

SINGLE yarns are twisted together to make a thread or twine when a level, strong, and compact thread is required for purposes such as sewing, carpet making, etc. Also, when a very heavy, strong thread is wanted, it must be made up of a number of singles. A single thread would be of little use; besides the tendency to untwist, the fibres on the outside of a yarn have not the same angle of twist as those in the inside. Owing to this there is a difference in tension between the outside and inside fibres and a strength proportional to the material used is not obtained. Fig. 68 will help to make this clear. If the yarn represented by *A* has its outside fibres lying at an angle shown by the line *C*, the fibres of the central portion *B*, which must, of course, have the same number of turns per inch, will lie along the flatter angle shown by the line *D*.

The thread must be twisted in the opposite direction to that of its component yarns; it will be found to twist that way naturally. The thread cannot be twisted in the same directions as its components; as each turn of twist on the thread adds a turn to the yarn, the yarn will resist this and the thread will simply untwist whenever it is released.

Twisting Machinery

When the number of single yarns (or *plies*) in a thread is small, say two or three, a very simple frame may be used. It is somewhat similar to a spinning frame, but with a slight difference in the drawing rollers. A sketch of the arrangement is given in Fig. 69.

The bobbins of yarn to be twisted are placed on the creel *A*. The single yarns pass through the guide *B*;

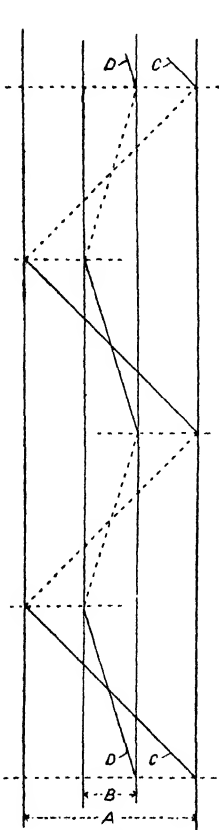

FIG. 68

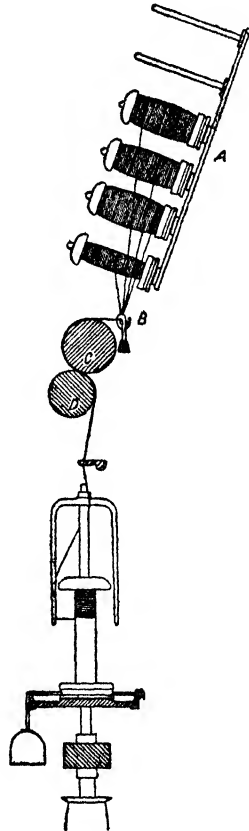

FIG. 69

over the top roller *C*; between it and the bottom roller *D*, and thence on to the flyer and bobbin. Both

top and bottom rollers are of metal, and each is of the same diameter throughout its length. The gearing of this style of frame is practically the same as the twist gearing of a spinning frame; there is no need, therefore, to consider it here.

Twisting Frame with Automatic Stop Motion

When the number of plies is from four up to seven, it is better to use a twisting frame with an automatic stop motion such as is shown by the sketch in Fig. 70. In this machine the yarns to be twisted are drawn from the bobbins in the creel, pass each through a detector *A*, and then by the path shown in the sketch to the flyer. In the event of a yarn breaking or of a bobbin emptying, the detector corresponding to that yarn drops and comes into contact with the revolving cam *F*, which pushes it back together with the whole bracket *G*. This bracket then strikes the long bent bracket *HK*, forcing it back also and causing the catch at *L* to come out of contact with the small bracket *M* on the machine framework. The tension pulley on the lever *N* hinged at *O*, which has been kept in position by *HK*, is thus allowed to drop, relieving the tension on the spindle driving band and so stopping the spindle. The other end of the lever *N* is at the same time forced upwards carrying the bracket *HK* with it. On the horizontal part *K* of this bracket is a projecting pin *P*, which, when *HK* moves upwards, lifts the arm of the lever *B*, which is hinged at *D*. The top boss *C*, carried on the other end of the lever, is thus thrown forward clear of the drawing roller and the delivery is stopped. The dropping of one of the detectors *A* thus stops both delivery and spindle.

The gearing of the two sides of this machine is shown in Fig. 71. The two sides of the machine are driven

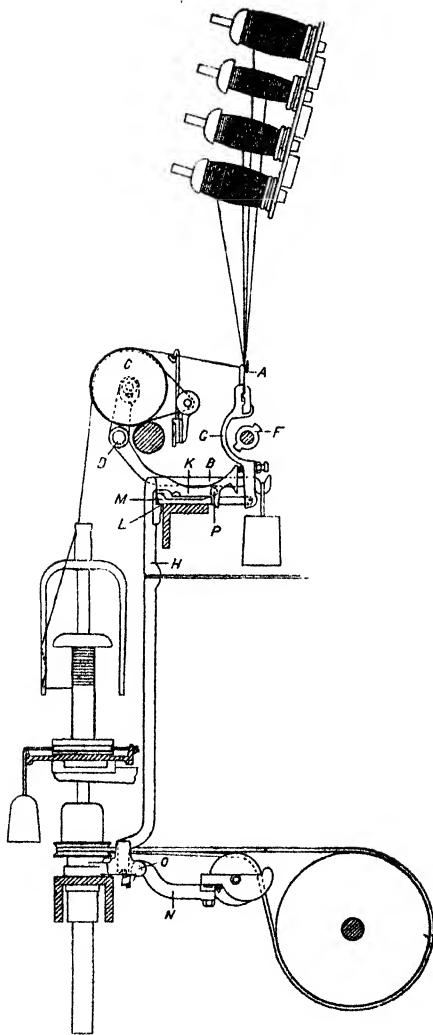

FIG. 70

from the one cylinder pinion. This 24 pinion on the end of the cylinder drives, through the double intermediate 80/120 and the single intermediate 130, the two 130's *A* and *B*. The drive is further continued from these on each side through the double intermediates 90/*CPB* to the pinions *CPA* on the two

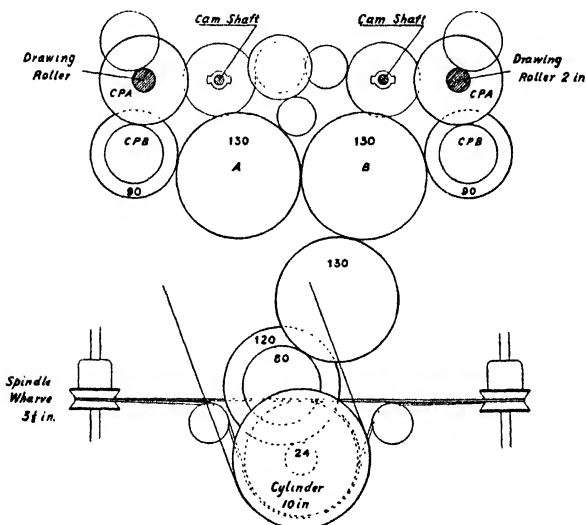

FIG. 71

drawing rollers. The drives are comparatively simple, but, as this is the first example we have had of two change pinions in a twist gearing, the calculation is given. Taking either drive, for one revolution of the drawing roller the spindle will make

$$\frac{CPA}{CPB} \times \frac{90}{80} \times \frac{120}{24} \times \frac{10}{3.5} \text{ revolutions}$$

Dividing this by the corresponding delivery, 2×3.14 in., we get

$$\frac{CPA}{CPB} \times \frac{90}{80} \times \frac{120}{24} \times \frac{10}{3.5} \times \frac{1}{2 \times 3.14} = \text{turns per inch}$$

$$\frac{CPA}{CPB} \times 2.56 = \text{turns per inch, } 2.56 \text{ being constant}$$

$$\frac{CPA}{CPB} = \frac{\text{turns per inch}}{2.56}$$

The pinions for any required twist may be found by using this result; for example: A twist of 4 turns per inch is required, to find the necessary change pinions

$$\frac{CPA}{CPB} = \frac{\text{turns per inch}}{2.56} = \frac{4}{2.56} = 1.56$$

or $CPA = CPB \times 1.56$

that is, the twist of 4 turns per inch will be obtained whenever CPA is 1.56 times the size of CPB , as for instance

39	for CPA ,	25	for CPB	
78	„	50	„	„
50	„	32	„	„ etc.

Again, if 1.5 turns per inch were wanted,

$$\frac{CPA}{CPB} = \frac{\text{turns per inch}}{2.56} = \frac{1.5}{2.56} = 0.59 \text{ nearly}$$

or $CPA = CPB \times 0.59$

To give a twist of 1.5 turns per inch, therefore, the pinions will be

if $CPB = 90$	then $CPA = 53$
„ $CPB = 80$	„ $CPA = 47$
„ $CPB = 70$	„ $CPA = 41$; etc.

Tube Twisting Frame

When the number of plies is seven or over, it is very necessary to have all the threads distributed properly so that there is no overlapping or crossing, as this

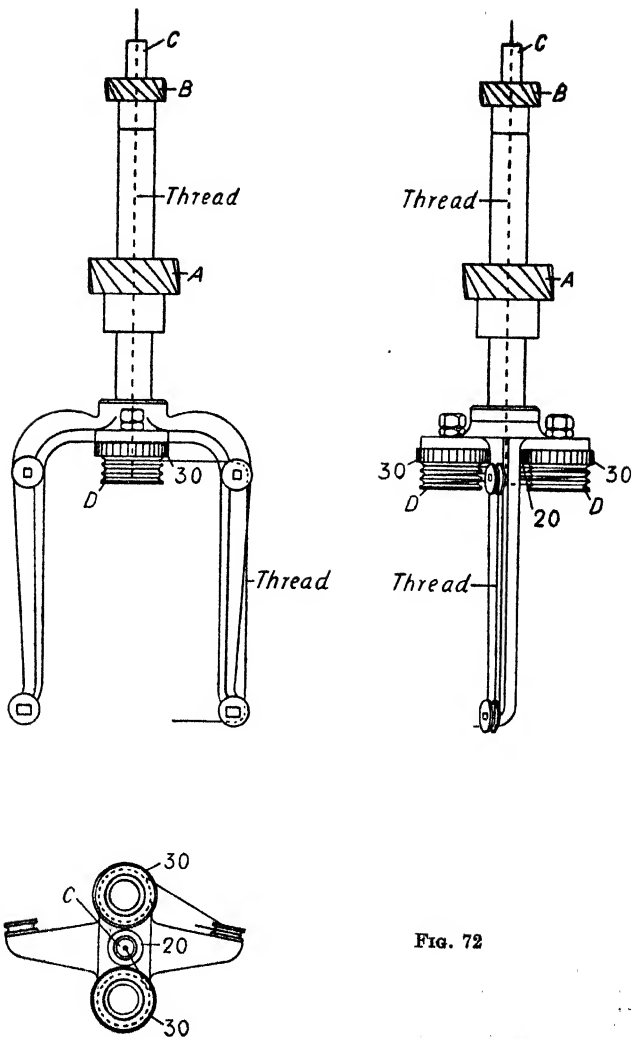

FIG. 72

would spoil the finished thread. In this case a much more complicated style of machine is employed, called a *tube twisting frame*.

In Fig. 72 we have a sketch of the flyer used in the machine. The helical pinion *A* is fixed on the flyer proper and is driven by another helical pinion on a shaft behind. The helical pinion *B* is fixed on the end

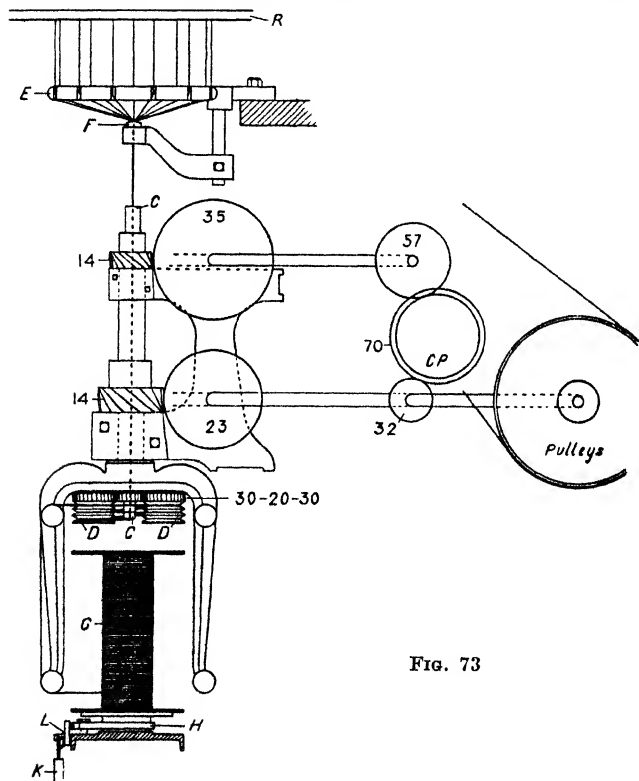

FIG. 73

of a tube C which goes right down through the shank of the flyer and is driven from another shaft at the back. The flyer and tube can thus be made to rotate at different speeds. On the bottom end of the tube C is fixed the small pinion of 20 teeth which gears with two 30-tooth wheels running on studs fixed to small brackets on the flyer. Coupled with the two 30's are two *haul* or *capstan* pulleys D , each with three grooves, and having an effective circumference of 5 in.

The general arrangement of the machine is shown in Fig. 73. The yarns come from the creel in front of the machine (not shown), pass over the rod R , round the outside of the register ring E , each yarn being kept in its proper place by a notch in the ring. The yarns then pass through a tight-fitting die F , which gives them, as a whole, a round shape, and also polishes them; from there they pass down through the tube CC , being twisted together into a thread as they pass down. The thread is then wound several times round the haul pulleys to ensure a firm hold, taken over the guide pulleys on the flyer arms and so on to the bobbin. Winding on is obtained in the usual way by means of a drag weight K acting through a lever L , to which is attached the steel *temper band* H .

If the flyer revolved and the tube were stationary, the 30-tooth wheels on the haul pulleys would be carried round the 20-tooth pinion on the tube C and would be made to revolve *on the flyer arm* in the same direction as the flyers (see Fig. 74 (a)). The thread lapped round the haul pulleys would, as a consequence, be passed on to the guide pulleys and so to the bobbin, and more thread would be pulled down the tube. The thread passing down the tube would be twisted by the rotation of the flyer.

If, however, the tube also were rotating in the same direction as the flyer, the movement of the 20-tooth

pinion would tend to turn the haul pulleys backwards (see Fig. 74 (b)) on the arm of the flyer, so that the ultimate effect on the haul pulleys would be the difference between the result due to the rotation of the flyer and that due to the rotation of the tube. In this way, then, with the flyer at a constant speed, we may vary the speed of the haul pulleys by altering the speed of the tube, thus altering the downpull on the thread and, as a consequence, the amount of twist given.

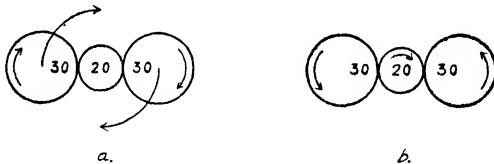

FIG. 74

To take examples ; we will suppose that the flyer is running at 450 revolutions per minute, and that the tube is standing, the haul pulleys being 5 in. effective circumference. When the flyer makes 450 revolutions, the two 30 wheels will run round the 20 pinion 450 times and will revolve *on the flyer arm*

$$\frac{450}{1} \times \frac{20}{30} = 300 \text{ times per minute}$$

The pull on the yarns due to the haul pulleys which are coupled with these wheels and round which the thread is lapped will be

$$300 \times 5 = 1500 \text{ inches per minute}$$

This amount will be made to pass down the tube and from the haul pulleys to the bobbin, the take up being ensured by the temper band and drag weight. But when passing down the tube, the yarns will be twisted

into a thread by the rotation of the flyer, the extent being

$$\frac{450}{1500} = 0.30 \text{ turns per inch.}$$

Suppose now that in the previous example the tube, instead of being stationary, were running at 360 revolutions per minute in the same direction as the flyer, the effect of this rotation of the tube would be to drive the haul pulleys backward to the extent of

$$\frac{360}{1} \times \frac{20}{30} = 240 \text{ r.p.m. on the flyer arm.}$$

The effect of the rotation of the flyers running at 450 r.p.m. on the haul pulleys was, as we saw, to drive them in the same direction as the flyer at

$$\frac{450}{1} \times \frac{20}{30} = 300 \text{ r.p.m. on the flyer arm.}$$

Combining the effects on the haul pulleys of the rotation of flyer and tube, we have

$$\frac{450}{1} \times \frac{20}{30} - \frac{360}{1} \times \frac{20}{30} = (450 - 360) \times \frac{20}{30} = 90 \times \frac{20}{30} = 60 \text{ r.p.m.}$$

of the haul pulleys relatively to the flyer arm. The downpull or delivery will be

$$60 \times 5 = 300 \text{ inches per minute}$$

and the twist on the yarn

$$\frac{450}{300} = 1.5 \text{ turns per inch.}$$

The tube is always driven more slowly than the flyer in practice. As its speed is altered to be more nearly that of the flyer, the delivery will become less and the turns per inch on the thread greater, both proportionally to the difference between the speeds of flyer and tube.

The arrangement of the gearing of this machine is shown diagrammatically in Fig. 73. The driving pulleys are on the bottom shaft; on this shaft also is a series of 23-toothed wheels driving the 14's on the flyers, and from it a 32 wheel drives, through the double intermediates 70/*CP*, a 57 on the top shaft. On this top shaft is another series of 35-toothed wheels which drive the 14's on the tubes.

Taking the pulleys as running at 300 revolutions per minute and the *CP* as having 69 teeth, we have

$$\text{Flyers,} \quad 300 \times \frac{23}{14} = 493 \text{ r.p.m.}$$

$$\text{Tube} \quad 300 \times \frac{32}{70} \times \frac{69}{57} \times \frac{35}{14} = 415 \text{ r.p.m.}$$

$$\begin{aligned} \text{Difference in r.p.m. between flyer and tube} \\ = 493 - 415 = 78 \text{ r.p.m.} \end{aligned}$$

$$\text{R.p.m. of haul pulleys relatively to flyer, } 78 \times \frac{20}{30} = 52$$

$$\text{Delivery in inches, } 78 \times \frac{20}{30} \times \frac{5}{1} = 260 \text{ per min.}$$

$$\text{Turns per inch on thread, } \frac{493}{260} = 1.9$$

The above may also be worked out from the relative speeds instead of the actual. Taking the flyer as running at 100 r.p.m. (if 1 r.p.m. be taken, too many decimals are involved), the speed of the tube will be

$$100 \times \frac{14}{23} \times \frac{32}{70} \times \frac{69}{57} \times \frac{35}{14} = 84.2 \text{ r.p.m.}$$

$$\begin{aligned} \text{Difference in speed between flyer and tube} \\ = 100 - 84.2 = 15.8 \text{ r.p.m.} \end{aligned}$$

$$\begin{aligned} \text{R.p.m. of haul pulleys relatively to flyer} \\ = 15.8 \times \frac{20}{30} = 10.53 \end{aligned}$$

$$\text{Delivery in in. per min.} = 15.8 \times \frac{20}{30} \times \frac{5}{1} = 52.6$$

$$\text{Twist on thread} = \frac{100}{52.6} = 1.9 \text{ turns per inch.}$$

The twist pinion for a given twist may be obtained by reversing the above procedure. If a twist of, say, 2.5 turns per inch were required, then, assuming that the speed of the flyer is 100 r.p.m.,

$$\frac{100}{2.5} = 40 \text{ inches to be delivered per minute}$$

$$\frac{40}{5} = 8 \text{ r.p.m. of haul pulleys relatively to flyers}$$

$$\frac{40}{5} \times \frac{30}{20} = 12 = \text{difference between r.p.m. of flyer and tube}$$

$$100 - 12 = 88 \text{ revolutions of tube per minute}$$

$$\frac{100}{1} \times \frac{14}{23} \times \frac{32}{70} \times \frac{CP}{57} \times \frac{35}{14} = \frac{88}{1}$$

whence $CP = 72 =$ change pinion for a twist of 2.5 turns per inch.

It is not practicable to have a constant for this machine. A general formula for the turns per inch may be worked out, but it is of little or no use practically. It is, on the whole, rather easier to work the whole thing out than to use the formula.

INDEX

- ACTION** in breaker card, 46
Adjustment—
of roving frame, 149
of traverse motion, spinning,
194
Amount of oil and water added
to jute, 39
BALE opening, 36
Batching jute, reasons for, 37
Belt drive, 10
Breaker card, 44
action in, 46
calculations and speeds, 52
change pinions, 64
clock length, 58
gearing, 49
production, 59
speed ratios, 55
Builder drive—
roving, 143, 162
spinning, 194
CALCULATIONS—
breaker card, 53, 55, 63
clock length, 58, 63
cone roving, 162
dollop and sliver, 77
expansion pulley roving, 166
finisher card, 73
open-link chain drawing, 98
pressure on pressing rollers,
93, 110
production, 59, 63, 73, 95, 112,
167, 190
proportion of roving to spinning
spindles, 195
push-bar drawing frame, 90
reeling, effect of short tell, 199
ring drawing frame, 101
rotary drawing frame, 115
roving, changing sizes, 153
—, drawing, 126
—, production, 167
Calculations—(*contd.*)
roving, summary, 147
—, traverse motion, 146
—, twisting, 128
—, winding-on, 138
spinning frame, 181
— —, changing sizes, 187
— —, production, 190
— —, traverse of builder,
194
spiral drawing, 108
system, 171
—, drafts and doublings, 173
—, r.p.m. of drawing rollers,
174
—, faller speeds, 176
twisting, stop motion twister,
207
—, tube twister, 213
Card pinning, 47
staves, 47
Carding action, 46
objects, 43
Changing sizes—
roving, 153
spinning, 187
Cone drive for roving, 157
Countershafts, 11
DIFFERENTIAL motion, 131
function of, 131
Differential wheel—
drive to, 137
effect of rotating, 131, 135
Discs and bowl, 139
Dollop—
and sliver calculations, 66, 77
meaning of, 43
Draft—
definition of, 19
constant, 22
method of calculating, 21
pinion, use of, 52

216 JUTE SPINNING CALCULATIONS

- Drawing**, 19
Drawing and doubling—
 definitions, 80
 objects, 80
Drawing frame—
 details, 84
 drawing roller, 81
 retaining rollers, 81
 types, 85
 —, open-link chain, 95
 —, push-bar, 86
 —, ring, 99
 —, rotary, 112
 —, spiral, 103
- EQUATIONS**—
 definition of, 25
 solutions of, 27
Expanding pulley for winding
 on motion, 164
- FINISHER card, the**, 68
 calculations, 72
 gearing, 70
 speeds, 71, 73
- GEARING**—
 breaker card, 49
 finisher card, 70
 open-link chain drawing frame
 96
 push-bar drawing frame, 88
 ring drawing frame, 99
 rotary drawing frame, 114
 roving frame, 125, 129, 137,
 144, 157, 164
 spinning frame, 181
 twisting frame, stop motion,
 204
 — —, tube, 210
- LEAD**—
 definition of, 23
 method of calculating, 24
- MISCELLANEOUS problems**—
 drawing frame, 116
 roving frame, 166
Moisture in jute, 40

- OIL and water added to jute**,
 amount of, 39
Open-link chain drawing, 95
 calculations, 97
- PIECING out**, 37
Pressure on pressing rollers, 93,
 110
Production, methods of calcu-
lating, 60, 167, 190
Proportion of roving to spin-
ning spindles, 195
Push-bar drawing frame, 86
 drive and path of fallers, 86
 gearing and calculations, 88
- RACK**, definition of, 3
Reeling, 196
 short tell, 199
Relative twists for different sizes
 of roves or yarns, 153,
 185
 weights for different diameters
 of rove, 150
Retaining rollers, 81
Ring drawing frame, 99
Rotary drawing frame, 112
 gearing and calculations, 115
Roving frame, 119
 adjustment, 149
 building the rove, 123
 builder drive, 143
 cone drive, 157
 calculations, changing sizes, 153
 —, drawing, 126
 —, traverse, 146, 162
 —, twisting, 128
 differential motion, 131
 discs and bowl, 139
 expanding pulley, 164
 index wheel, 140
 scroll plate and scroll, 140
 twisting, 120
 winding on, 121
 winding-on mechanism, 129
- SCREW and worm wheel**, 15
Screws, 13
Scroll plate and scroll, 140
Softener, the, 38

- Spindle speeds—
 roving, 170
 spinning, 186
- Spinning frame, 179
 adjustment, 186
 calculations, 182
 gearing, 181
 operations on, 179
 production, 190
 spindle speeds, 186
 traverse motion, 191
 winding on, 191
- Spiral drawing frame, 103
 faller mechanism, 103
 gearing, 106
 calculations, 108
- Surface speed, method of calculating, 18
- System—
 calculations, 169
 definition, 80
 working details, 177
- TOOTHED wheels, 1
 pitch circles of, 2
 — of teeth of, 3
- Train of wheels, 8
- Transmission of motion, 1
- Traverse motion—
 roving frame, 144
 spinning frame, 191
- Twist—
 constants for yarn, 185
- Twist—(contd.)
 method of calculating, 128
 on rove, 152
- Twisting frame, stop motion, 204
 — — —, tube, 207
- Twisting on roving frame, 120
- WATER and oil, amount added
 to jute, 39
- Weight of jute bale, 36
- Wheel and pinion, 3
- Wheels—
 bevel, 9
 double intermediate, 6
 single intermediate, 4
 toothed, 1
 train of, 8
- Winding-on—
 roving, 121
 spinning, 191
 mechanism, roving, 129
 —, spinning, 181
- Winding-on motion, methods of
 regulating—
 cone drive, 157
 discs and bowl, 139
 expanding pulley, 164
- YARN—
 relative twist on different
 yarns, 185
 tables, 198
 twist constants for, 184

PUBLISHED BY PITMAN

The Marketing of Wool

By A. F. DU PLESSIS, M.A.

A comprehensive study of the organization of the marketing of wool. Sections are devoted to the production, manufacture, and preparation of wool for the market.

In demy 8vo, cloth gilt, 350 pp. 12s. 6d. net.

Hosiery Manufacture

By PROFESSOR W. DAVIS, M.A., *Head of the Department of Textiles at University College, Nottingham.*

A treatise showing the development and application of the principles of knitted fabric manufacture.

In demy 8vo, cloth gilt, 146 pp., with 61 illustrations, including numerous photo-micrographs and sketches of mechanism. 5s. net. Second Edition.

Handbook of Weaving and Manufacturing

By HENRY GREENWOOD, F.T.I., M.R.S.T.

This book forms an extremely valuable and practical guide which should be in the hands of all students, weavers, overlookers, managers, and others engaged in the textile industry. Containing yarn and cloth calculations, types of yarns, conversion tables, loom drafts, tie-ups and peg plans, details of all manufacturing machines, sizing, faults, and timing of all machines, with notes on mill driving, humidifying, ventilation, and artificial silk.

In crown 8vo, cloth gilt, 136 pp., illustrated. 5s. net.

The Testing of Yarns and Fabrics

By HARRY P. CURTIS.

For manufacturers, warehousemen, and operatives, also for drapers, laundrymen, and clothiers.

In crown 8vo, cloth gilt, 168 pp., with 60 illustrations. 5s. net.

Introduction to Textiles

By A. E. LEWIS, A.M.C.T., A.T.I.

This book is intended for students of any special branch of textile and also for those engaged in the textile industry. It contains a complete survey of the different textile fibres and their preparation, and also brief accounts of the various processes which are used in textile manufacture.

In crown 8vo, cloth gilt, 100 pp. 3s. 6d.

The Design and Manufacture of Towels and Towelling

By THOMAS WOODHOUSE, F.T.I., and ALEXANDER BRAND, A.T.I.

A comprehensive textbook on the subject which will prove of interest to those already in possession of a knowledge of the general principles and practice of weaving, to those engaged in the distributing trades, to students and managers, and to all those with a more advanced knowledge of the subject.

In demy 8vo, cloth gilt, 243 pp., with 173 illustrations. 12s. 6d. net.

PUBLISHED BY PITMAN

Artificial Silk or Rayon : Its Manufacture and Uses

By THOMAS WOODHOUSE, F.T.I.

The nature of the four principal types of artificial silk—nitro-cellulose, cuprammonium, viscose, and cellulose acetate is very clearly explained, and a detailed account is given of the chief operations involved in the separation of the cellulose from the raw materials, the making of the yarns, and the subsequent processes of warping, sizing, beaming, weaving, and knitting.

In demy 8vo, cloth gilt, 255 pp., with 110 illustrations. Second Edition. **7s. 6d.** net.

Artificial Silk or Rayon, The Preparation and Weaving of

By the same Author.

A practical book for textile workers and students, covering the machinery, operation, and processes of this branch of the industry.

In demy 8vo, cloth gilt, 240 pp., illustrated. **10s. 6d.** net.

Wool : From the Raw Material to the Finished Product

By J. A. HUNTER.

CONTENTS: PREFACE—Wool and Sheep—The Wool Industries—Wool and its Marketing—Combing and Spinning—Cards and Mules—Cloth Making—The Nature of Cloth—Textile Testing—Houses and Technical Schools—The Finance of the Industry—Trade Combinations—Products and By-products—The Personnel of the Industry—Wool in Warfare—Glossary—Appendix—Index.

In crown 8vo, cloth, 140 pp., illustrated. **3s.** net. Fourth Edition.

The Jute Industry

By T. WOODHOUSE and P. KILGOUR.

Describes all the processes involved in the cultivation of jute plants, the extraction of the fibre, and the transformation of the fibre into useful commodities.

In crown 8vo, cloth, 143 pp., illustrated. **3s.** net.

Cordage and Cordage Hemp and Fibres

By T. WOODHOUSE and P. KILGOUR.

Discusses the methods employed in the manufacture, the machinery used, and the sources of the fibres of the various types of cordage.

In crown 8vo, cloth, 123 pp., illustrated. **3s.** net.

A First Year Cotton Spinning Course

By H. A. J. DUNCAN, A.T.I.

The book is divided into three sections: Cotton Spinning, Textile Mathematics, and Textile Drawing, and covers the requirements of the first-year student in a thoroughly practical manner.

In crown 8vo, cloth gilt, 240 pp. **3s. 6d.**

Sir Isaac Pitman & Sons, Ltd., Parker Street, Kingsway, London, W.C.2

An Abridged List of TECHNICAL BOOKS

published by

Sir Isaac Pitman & Sons, Ltd.

*A complete Catalogue of Technical and Scientific
Books will be sent post free on request*

*All prices are net, except those marked **

TEXTILE MANUFACTURE, ETC.

	<i>s.</i>	<i>d.</i>
COTTON SPINNER'S POCKET BOOK, THE. By J. F. Innes. 3rd Ed.	3	6
*COTTON SPINNING COURSE, A FIRST YEAR. By H. A. J. Duncan, A.T.I.	3	6
JUTE SPINNING CALCULATIONS. By Andrew Smith	5	0
PATTERN CONSTRUCTION, THE SCIENCE OF. For Garment Makers. By B. W. Poole, M.R.S.T. Second Edition.	45	0
TAILORING, PRACTICAL. By J. E. Liberty, U.K.A.F.	7	6
TAILORING, SIMPLIFIED, LADIES. By M. E. D. Galbraith	7	6
*TEXTILES, INTRODUCTION TO. By A. E. Lewis, A.M.C.T.	3	6
WORSTED CARDING AND COMBING. By J. R. Hind, M.R.S.T.	7	6
WORSTED OPEN DRAWING. By S. Kershaw, F.T.I.	5	0
YARNS AND FABRICS, THE TESTING OF. By H. P. Curtis, P.T.I. Second Edition	5	0

DRAUGHTSMANSHIP

APPLIED PERSPECTIVE. By John Holmes, F.R.S.A.	6	6
*ENGINEERING DRAWING, A FIRST YEAR. By A. C. Parkinson, A.C.P. (Hons.), F.Coll.H. Second Edition	5	0
ENGINEERING DRAWING, INTERMEDIATE. By A. C. Parkinson, A.C.P. (Hons.), F.Coll.H. Second Edition	7	6
*ENGINEERING WORKSHOP DRAWING. By A. C. Parkinson, A.C.P. (Hons.), F.Coll.H. Fourth Edition	4	0
*FOUNDATIONS OF TECHNICAL DRAWING. By A. C. Parkinson, A.C.P. (Hons.), F.Coll.H.	2	6
PLAN COPYING PROCESSES AND EQUIPMENT, MODERN. By B. J. Hall, M.I.Mech.E., and B. Fairfax Hall, M.A.	5	0
Limp cloth edition	4	0

CHEMISTRY, PHARMACY, ETC.

DISPENSING FOR PHARMACEUTICAL STUDENTS. By J. W. Cooper, Ph.C., and F. J. Dyer. Sixth Edition, Revised and re-written by J. W. Cooper	<i>s. d.</i>
*LATIN FOR PHARMACEUTICAL STUDENTS. By J. W. Cooper and A. C. McLaren. Third Edition	8 6
PHARMACEUTICAL CHEMISTRY, PRACTICAL. By F. N. Appleyard, B.Sc. (Lond.), F.I.C., Ph.C., and C. G. Lyons. Third Edition	6 0
PHARMACEUTICAL CHEMISTRY, THEORETICAL. By C. G. Lyons, M.A., Ph.D. (Cantab.)	6 6
PHARMACOGNOSY, TEXTBOOK OF. By J. W. Cooper, Ph.C., and T. C. Denston, B.Pharm., Ph.C. With illustrations and drawing notes by M. Riley, A.T.D., and D. W. Shaw, B.Sc., Ph.C. Second Edition	12 6
TUTORIAL PHARMACY. By J. W. Cooper, Ph.C. Third Edition	18 0
VOLUMETRIC ANALYSIS. By J. B. M. Coppock, Ph.D., B.Sc., A.I.C., and J. B. Coppock, B.Sc. (Lond.), F.I.C., F.C.S. Third Edition	17 6
	3 6

PLASTICS

ARTIFICIAL RESINS. By J. Scheiber, Ph.D., and Kurt Sändig. Translated by Ernest Fyleman, B.Sc., Ph.D., F.I.C.	15 0
CELLULOSE LACQUERS, THE. By S. Smith, O.B.E.	7 6
PLASTICS AND MACHINERY IN THE PLASTICS INDUSTRY. By Kurt Brandenburger. Translated by H. I. Lewenz, M.I.Mech.E.	25 0

METALLURGY, FOUNDRYWORK, ETC.

ALUMINIUM AND ITS ALLOYS. By N. F. Budgen, Ph.D., M.Sc.	15 0
ELECTROPLATING. By S. Field, A.R.C.Sc., and A. Dudley Weill. Third Edition	12 6
ENGINEERING MATERIALS. By A. W. Judge, Wh.Sc., A.R.C.S. In three volumes—Vol. I, FERROUS, 30s.; Vol. II, NON-FERROUS, 40s.; Vol. III, THEORY AND TESTING OF MATERIALS, 21s.	
METAL WORK, PRACTICAL SHEET AND PLATE. By E. A. Atkins, M.Sc., M.I.Mech.E., M.I.W. Fourth Edition	7 6
METALLURGY OF BRONZE. By H. C. Dews	12 6
METALLURGY OF CAST IRON. By J. E. Hurst	15 0
METALS AND ALLOYS, THE MECHANICAL TESTING OF. By P. Field Foster, B.Sc., M.Sc., A.M.I.Mech.E.	15 0
PANEL BEATING AND SHEET METAL WORK. By Sidney Pinder	4 0
SPECIAL STEELS. Chiefly founded on the Researches regarding Alloy Steels of Sir Robert Hadfield, Bt., D.Sc., etc. Second Edition. By T. H. Burnham, B.Sc. Hons. (Lond.), A.M.I.Mech.E., M.I.Mar.E.	12 6
WELDING, ELECTRIC ARC AND OXY-ACETYLENE. By E. A. Atkins, M.I.Mech.E., etc. and A. G. Walker, M.Inst.W. Third Edition	8 6
WELDING, ELECTRIC, THE PRINCIPLES OF. By R. C. Stockton, A.I.M.M., A.M.C.Tech.	7 6

MINERALOGY AND MINING

For particulars of Pitman Books on the above subjects, send for separate list.

CIVIL ENGINEERING, BUILDING, ETC.

ARCHITECTURAL HYGIENE; OR, SANITARY SCIENCE AS APPLIED TO BUILDINGS. By Sir Bannister Fletcher, M.Arch. (Ireland), F.S.I., <i>Barrister-at-Law</i> , and Major H. Phillips Fletcher, D.S.O., F.R.I.B.A., F.S.I., etc. Sixth Edition	s. d. 10 6
ARCHITECTURAL PRACTICE AND ADMINISTRATION. By H. Ingham Ashworth, B.A., A.R.I.B.A.	12 6
BRICKWORK, CONCRETE, AND MASONRY. Edited by T. Corkhill, M.I.Struct.E. In eight volumes <i>Each</i>	6 0
BUILDING ENCYCLOPAEDIA, A CONCISE. Compiled by T. Corkhill, M.I.Struct.E.	7 6
*BUILDING GEOMETRY. By Richard Greenhalgh, A.I.Struct.E.	4 6
BUILDING, MECHANICS OF. By Arthur D. Turner, A.C.G.I., A.M.Inst.C.E.	5 0
ENGINEERING EQUIPMENT OF BUILDINGS. By A. C. Pallot, B.Sc. (Eng.)	15 0
FABRIC OF MODERN BUILDINGS, THE. By E. G. Warland, M.I.Struct.E.	20 0
FLATS, DESIGN AND EQUIPMENT. By H. Ingram Ashworth, B.A., A.R.I.B.A.	25 0
HYDRAULICS. By E. H. Lewitt, B.Sc. (Lond.), A.M.I.M.E. Fifth Edition	10 6
JOINERY AND CARPENTRY. Edited by R. Greenhalgh, A.I.Struct.E. In six volumes <i>Each</i>	6 0
PAINTING AND DECORATING. Edited by C. H. Eaton, F.I.B.D. In six volumes <i>Each</i>	7 6
PLUMBING AND GASFITTING. Edited by Percy Manser, R.P., A.R.S.I. In seven volumes <i>Each</i>	6 0
PLUMBING ENGINEERING. By Walter S. L. Cleverdon	12 6
REINFORCED CONCRETE ARCH DES.GN. By G. P. Manning, M.Eng., A.M.Inst.C.E.	12 6
STRUCTURES, THE THEORY OF. By H. W. Coultas, M.Sc., A.M.I.Struct.E., A.I.Mech.E. Second Edition	18 0
SURVEYING, ADVANCED. By Alex. H. Jameson, M.Sc., M.Inst.C.E.	12 6
WATER SUPPLY PROBLEMS AND DEVELOPMENTS. By W. H. Maxwell, A.M.Inst.C.E. Second Edition	25 0
WATERWORKS FOR URBAN AND RURAL DISTRICTS. By H. C. Adams, M.Inst.C.E., M.I.M.E., F.R.S.I. Third Edition	15 0
WOODWORKING BY MACHINERY. By Robert H. Hordern	4 0

MECHANICAL ENGINEERING

CONDENSER, THE SURFACE. By B. W. Pendred, A.M.I.Mech.E.	8 6
ENGINEERING EDUCATOR, PITMAN'S. Edited by W. J. Kearton, D.Eng., M.I.Mech.E., A.M.Inst.N.A. In three volumes. Second Edition	63 0

Mechanical Engineering—contd.

*ENGINEERING, INTRODUCTION TO. By R. W. J. Pryer, B.Sc. (Eng.), A.M.I.Mech.E., A.M.I.A.E.	s. d.
	2 0
*ENGINEERING SCIENCE, EXPERIMENTAL. By Nelson Harwood, B.Sc., A.M.I.Mech.E.	7 6
ENGINEERING SCIENCE, MECHANICAL AND ELECTRICAL, FIRST YEAR. By G. W. Bird, Wh.Ex., A.M.I.Mech.E., etc. Revised by B. J. Tams, M.Sc.Tech., A.M.I.Mech.E. Second Edition	5 0
ENGINEERING SCIENCE, MECHANICAL, SECOND YEAR. By G. W. Bird, Wh.Ex., B.Sc., A.M.I.Mech.E., etc.	5 0
HYDRAULICS. By E. H. Lewitt, B.Sc. Fifth Edition	10 6
HYDRAULICS FOR ENGINEERS. By R. W. Angus, B.A.Sc., M.E. Second Edition	12 6
HYDRO- AND AERO-DYNAMICS. By S. L. Green, M.Sc.	12 6
MACHINES PROBLEMS, EXAMPLES IN THEORY OF. By W. R. Craw- ford, M.Sc., Ph.D.	5 0
*MECHANICS FOR ENGINEERING STUDENTS. By G. W. Bird, B.Sc., A.M.I.Mech.E. Revised by G. W. T. Bird, B.Sc. Third Edition	5 0
STEAM TURBINE OPERATION. By W. J. Kearton, D.Eng., M.I.Mech.E., A.M.Inst.N.A. Third Edition	12 6
STEAM TURBINE THEORY AND PRACTICE. By W. J. Kearton, D.Eng., M.I.M.E., A.M.Inst.N.A. Third Edition	15 0
STRENGTH OF MATERIALS. By F. V. Warnock, Ph.D., M.Sc. (Lond.), F.R.C.Sc.I., A.M.I.Mech.E. Third Edition	10 6
SUPERHEATER IN MODERN POWER PLANT. By D. W. Rudorff, Dipl. Ing., A.Am.I.E.E., M.Inst.F.	21 0
THEORY OF MACHINES. By Louis Toft, M.Sc.Tech., and A. T. J. Kersey, A.R.C.Sc. Third Edition	12 6
THERMODYNAMICS, APPLIED. By William Robinson, M.E., M.Inst.C.E., M.I.Mech.E. Revised by John M. Dickson, B.Sc. Second Edition	18 0
THERMODYNAMICS APPLIED TO HEAT ENGINES. By E. H. Lewitt, B.Sc., A.M.I.Mech.E. Second Edition	12 6
THERMODYNAMICS PROBLEMS, EXAMPLES IN. By W. R. Crawford, M.Sc., Ph.D.	5 0
THERMODYNAMICS, TECHNICAL. By Professor Dipl.-Ing. W. Schüle. Translated from the German by E. W. Geyer, B.Sc.	40 0
WORKSHOP PRACTICE. Edited by E. A. Atkins, M.I.Mech.E., M.I.W.E. In eight volumes	6 0

AERONAUTICAL

Write for separate list of over 60 books on aeronautics and aeronautical engineering.

MOTOR ENGINEERING, ETC.

Write for the complete list of motoring books, containing over 50 titles.

OPTICS AND PHOTOGRAPHY

APPLIED OPTICS, INTRODUCTION TO. By L. C. Martin, D.Sc., A.R.C.S., D.I.C. Vol. I. GENERAL AND PHYSIOLOGICAL. Vol. II. THEORY AND CONSTRUCTION OF INSTRUMENTS. In two volumes. Each	5. d. 21 0
CAMERA IN COMMERCE, THE. By David Charles, F.R.P.S.	10 6
CAMERA LENSES. By A. W. Lockett. Revised by H. W. Lee. Second Edition	2 6
COLOUR PHOTOGRAPHY IN PRACTICE. By D. A. Spencer, Ph.D., F.I.C., F.R.P.S.	21 0
COLOUR SENSITIVE MATERIALS. By Robert M. Fanstone, A.R.P.S.	8 6
PHOTOGRAPHIC CHEMICALS AND CHEMISTRY. By J. Southworth and T. L. J. Bentley, D.I.C., A.R.C.Sc., B.Sc.	3 6
PHOTOGRAPHY THEORY AND PRACTICE. By L. P. Clerc. Edited by the late G. E. Brown, F.I.C., etc. Second Edition .	35 0
RETOUCHING AND FINISHING FOR PHOTOGRAPHERS. By J. S. Adamson. Third Edition	4 0
STUDIO PORTRAIT LIGHTING. By H. Lambert, F.R.P.S. Second Edition	15 0

ELECTRICAL ENGINEERING, ETC.

ACCUMULATOR CHARGING, MAINTENANCE, AND REPAIR. By W. S. Ibbetson. Sixth Edition	4 6
ALTERNATING CURRENT BRIDGE METHODS. By B. Hague, D.Sc. Fourth Edition	25 0
ALTERNATING CURRENT CIRCUIT. By Philip Kemp. M.Sc., M.I.E.E., Mem.A.I.E.E. Second Edition	2 6
ALTERNATING CURRENT MACHINES, PERFORMANCE AND DESIGN OF. By M. G. Say, Ph.D., M.Sc., A.C.G.I., D.I.C., A.M.I.E.E., F.R.S.E., and E. N. Pink, B.Sc., A.M.I.E.E.	20 0
ALTERNATING CURRENT WORK. By W. Perren Maycock, M.I.E.E. Second Edition	7 6
ALTERNATING CURRENTS, THE THEORY AND PRACTICE OF. By A. T. Dover, M.I.E.E. Second Edition	18 0
AUTOMATIC PROTECTIVE GEAR FOR A.C. SUPPLY SYSTEMS. By J. Henderson, M.C., B.Sc., A.M.I.E.E.	7 6
CHANGEOVER OF D.C. SUPPLY SYSTEMS TO THE STANDARD SYSTEM OF A.C. DISTRIBUTION. By S. J. Patmore, A.M.I.E.E.	3 6
DIRECT CURRENT MACHINES, PERFORMANCE AND DESIGN OF. By A. E. Clayton, D.Sc., M.I.E.E.	16 0
ELECTRIC CLOCKS, MODERN. By Stuart F. Philpott, A.M.I.E.E. Second Edition	7 6
ELECTRIC LIGHTING AND POWER DISTRIBUTION. By W. Perren Maycock, M.I.E.E. Ninth Edition, thoroughly revised by C. H. Yeaman. In two volumes Each	10 6
ELECTRIC MOTOR CONTROL GEAR, INDUSTRIAL. By W. H. J. Norburn, A.M.I.E.E.	10 6
ELECTRIC PLANT, PROTECTION OF (MODERN DEVELOPMENTS). By F. P. Stritzl, D.Sc.Tech. (Vienna)	15 0

Electrical Engineering, etc.—contd.

ELECTRIC TRACTION. By A. T. Dover, M.I.E.E., Assoc. Amer.I.E.E. Second Edition	s. d. 25 0
ELECTRIC WIRING, FITTINGS, SWITCHES, AND LAMPS. By W. Perren Maycock, M.I.E.E. Sixth Edition. Revised by Philip Kemp, M.Sc., M.I.E.E., etc.	10 6
ELECTRIC WIRING TABLES. By W. Perren Maycock, M.I.E.E., Seventh Edition Revised by P. C. Raphael, M.I.E.E.	3 6
ELECTRICAL CONTRACTING, ORGANIZATION, AND ROUTINE. By H. R. Taunton	12 6
ELECTRICAL ENGINEERING, CLASSIFIED EXAMPLES IN. By S. Gordon Monk, M.Sc. (Eng.), B.Sc., A.M.I.E.E. In two parts. *Vol. I. DIRECT CURRENT. Fourth Edition *Vol. II. ALTERNATING CURRENT. Fourth Edition	2 6 4 0
ELECTRICAL ENGINEERING, EXPERIMENTAL. By F. T. A. Rapson, A.C.G.I., D.I.C., M.Sc. (Eng.) London, etc. Second Edition.	3 6
ELECTRICAL MEASUREMENTS AND MEASURING INSTRUMENTS. By E. W. Golding, M.Sc.Tech., A.M.I.E.E., M.A.I.E.E. Second Edition	20 0
ELECTRICAL MEASURING INSTRUMENTS, INDUSTRIAL. By Kenelm Edgcumbe, M.Inst.C.E., M.I.E.E., F.Inst.P., and F. F. J. Ockenden, A.M.I.E.E. Third Edition.	25 0
ELECTRICAL TECHNOLOGY. By H. Cotton, M.B.E., D.Sc., A.M.I.E.E. Third Edition	12 6
ELECTRICAL TERMS, A DICTIONARY OF. By S. R. Roget, M.A., A.M.Inst.C.E., A.M.I.E.E. Third Edition	8 6
ELECTRICAL WIRING AND CONTRACTING. Edited by H. Marryat, M.I.E.E., M.I.Mech.E. In seven volumes	Each 6 0
ELECTRICITY, FOUNDATIONS OF TECHNICAL. By E. Mallett, D.Sc., M.Inst.C.E., M.I.E.E., F.Inst.P., and T. B. Vinycomb, M.C., M.A., F.Inst.P.	5 0
GENERATION, TRANSMISSION AND UTILIZATION OF ELECTRICAL POWER. By A. T. Starr, M.A., Ph.D., B.Sc., A.M.I.E.E.	18 0
INSTRUMENT TRANSFORMERS: THEIR THEORY, CHARACTERISTICS AND TESTING. By B. Hague, D.Sc. (Lond.), Ph.D. (Glas.), F.C.G.I., etc.	35 0
METER ENGINEERING. By J. L. Ferns, B.Sc. (Hons.), A.M.C.T. Second Edition	10 6
PHOTOELECTRIC CELL APPLICATIONS. By R. C. Walker, B.Sc. (Lond.), and T. M. C. Lance, Assoc.I.R.E. Third Edition	12 6
POWER WIRING DIAGRAMS. By A. T. Dover, M.I.E.E., A.Amer. I.E.E. Third Edition	6 0
SWITCHGEAR, OUTDOOR HIGH VOLTAGE. By R. W. Todd, A.M.I.E.E., Assoc.A.I.E.E., and W. H. Thompson, A.M.I.E.E. 42 0	
SYMMETRICAL COMPONENT THEORY, ELEMENTS OF. By G. W. Stubbings, B.Sc. (Lond.), F.Inst.F., A.M.I.E.E.	5 0

TELECOMMUNICATIONS

ELECTRIC CIRCUITS AND WAVE FILTERS. By A. T. Starr, M.A., Ph.D., A.M.I.E.E. Second Edition	s. d.
RADIO COMMUNICATION, MODERN. By J. H. Reyner. In two volumes—Vol. I. Sixth Edition, 5s. Vol. II. Second Edition, 7s. 6d.	21 0
RADIO ENGINEERING, PROBLEMS IN. By E. T. A. Rapson, A.C.G.I., D.I.C., A.M.I.E.E. Third Edition	3 6
RADIO RECEIVER CIRCUITS HANDBOOK. By E. M. Squire	4 6
RADIO RECEIVER SERVICING AND MAINTENANCE. By E. J. G. Lewis. Second Edition	8 6
RADIO, SHORT-WAVE. By J. H. Reyner	8 6
RADIO UPKEEP AND REPAIRS FOR AMATEURS. By Alfred Witts, A.M.I.E.E. Third Edition	5 0
SUPERHETERODYNE RECEIVER, THE. By Alfred T. Witts, A.M.I.E.E. Third Edition	3 6
TELEGRAPHY. By T. E. Herbert, M.I.E.E. Sixth Edition	20 0
TELEGRAPHY AND TELEPHONY, ARITHMETIC OF. By T. E. Herbert, M.I.E.E., and R. G. de Wardt	5 0
TELEPHONE HANDBOOK AND GUIDE TO THE TELEPHONIC EXCHANGE, PRACTICAL. By Joseph Poole, A.M.I.E.E. (Wh.Sc.). Seventh Edition	18 0
TELEPHONY. By T. E. Herbert, M.I.E.E., and W. S. Procter, A.M.I.E.E. In two volumes. Vol. I. MANUAL SWITCHING SYSTEMS AND LINE PLANT. Second Edition	20 0
Vol. II. AUTOMATIC TELEPHONY	20 0
TELEVISION ENGINEERING. By J. C. Wilson	30 0
TELEVISION OPTICS. By L. M. Myers. Second Edition	30 0
TELEVISION RECEPTION TECHNIQUE. By Paul D. Tyers	12 6
WIRELESS, A FIRST COURSE IN. By "Decibel"	4 0

**MATHEMATICS AND CALCULATIONS
FOR ENGINEERS**

CALCULUS FOR ENGINEERS AND STUDENTS OF SCIENCE. By John Stoney, B.Sc., A.M.I.Min.E., M.R.San.I. Second Edition	6 0
EXPONENTIAL AND HYPERBOLIC FUNCTIONS. By A. H. Bell, B.Sc.	3 6
GRAPHS OF STANDARD MATHEMATICAL FUNCTIONS. By H. V. Lowry, M.A.	2 0
LOGARITHMS FOR BEGINNERS. By C. N. Pickworth, Wh.Sc. Eighth Edition	1 6
*LOGARITHMS SIMPLIFIED. By Ernest Card, B.Sc., and A. C. Parkinson, A.C.P. Second Edition	2 0
MATHEMATICS, ELEMENTARY PRACTICAL. In three volumes, each 5s. By E. W. Golding, M.Sc., Tech., A.M.I.E.E., and H. G. Green, M.A. Book I. First Year. Book II. Second Year. Book III. Third Year.	

Mathematics and Calculations for Engineers—contd.

MATHEMATICS, PRACTICAL. By Louis Toft, M.Sc. (Tech.), and A. D. D. McKay, M.A.	s. d. 12 6
NOMOGRAM, THE. By H. J. Allcock, B.Sc., A.M.I.E.E., A.M.I.Mech.E., and J. R. Jones, M.A., F.G.S.	10 6

MISCELLANEOUS TECHNICAL BOOKS

ACOUSTICAL ENGINEERING. By W. West, B.A., A.M.I.E.E.	15 0
ENGINEERING ECONOMICS. By T. H. Burnham, B.Sc. Hons. (Lond.), B.Com. (Lond.), F.I.I.A., A.M.I.Mech.E., M.I.Mar.E. In two volumes, each 8s. 6d. Book I. Elements of Industrial Organization and Management. Book II. Works Organization and Management.	
ENGINEERING INQUIRIES, DATA FOR. By J. C. Connan, B.Sc., A.M.I.E.E., O.B.E.	12 6
FOUNDRY ORGANIZATION AND MANAGEMENT. By James J. Gillespie	12 6
MOTOR BOATING, THE SAFETY WAY IN. By A. H. Lindley-Jones	5 0
SAILING CRAFT, SMALL. By John F. Sutton, M.Sc. (Eng.), A.M.I.M.E. Second Edition	5 0
SCIENCE, THE MARCH OF. A First Quinquennial Review, 1931-35. By Various Authors. Issued under the authority of the Council of the British Association for the Advancement of Science	3 6
SHOE REPAIRER'S HANDBOOKS. By D. Laurence-Lord. In seven volumes	Each 3 6
TEACHING METHODS FOR TECHNICAL TEACHERS. By J. H. Currie M.A., B.Sc., A.M.I.Mech.E.	2 6
WITH THE WATCHMAKER AT THE BENCH. By Donald de Carle. F.B.H.I. Third Edition	8 6
WORKS ENGINEER, THE. By W. R. J. Griffiths, M.Inst.F., A.M.S.W.I.E. In Collaboration with W. O. Skeat, B.Sc. (Eng.), G.I.Mech.E., etc.	21 0

PITMAN'S TECHNICAL PRIMERS

Each in foolscap 8vo, cloth, about 120 pp., illustrated	2 6
The Technical Primer Series consisting of about 40 titles is intended to enable the reader to obtain an introduction to whatever technical subject he desires. Please send for complete list of titles, sent post free on request.	

**COMMON COMMODITIES AND
INDUSTRIES SERIES**

Each book in crown 8vo, cloth, with many illustrations, etc.	3 0
In each of the handbooks in this series a particular product or industry is described by an expert writer and practical man of business. Write for complete list of titles, sent post free on application.	

DATE OF ISSUE

This book must be returned within 3/7/14 days of its issue. A fine of ONE ANNA per day will be charged if the book is overdue.

--	--	--	--	--

