

BIREL

JL LIBRARY

PILANI [RAJASTHAN]

Class No. E 71 0942.

Book No. D 92 B

Accession No. 59212

The
ENGINEER SERIES

PAPER-MAKING AND ITS MACHINERY

By T. W. CHALMERS, B.Sc., A.M.I. Mech. E.
Imperial 8vo. Illustrated. **26** - net

**THE PRODUCTION AND TREATMENT OF
VEGETABLE OILS**

By T. W. CHALMERS, B.Sc., A.M.I. Mech. E.
Imperial 8vo. Folding Plates and Illustrations
21 - net

**ELECTRIC WELDING AND WELDING
APPLIANCES**

By H. CARPMAEL, A.M.I.C.E., A.M.I.E.E.
Imperial 8vo. Illustrated. **18** - net.

**DEVELOPMENTS IN POWER - STATION
DESIGN**

By EDWIN AUSTIN. Imperial 8vo. Folding
Plates and Illustrations. **31.6** net.

THE GYROSCOPIC COMPASS

A Non-Mathematical Treatment of the Theory
and Practical Construction of the Gyroscopic
Compass. By T. W. CHALMERS, B.Sc.,
A.M.I. Mech. E. Demy 8vo. Illustrated.
11 - net.

**WHAT INDUSTRY OWES TO CHEMICAL
SCIENCE**

By RICHARD B. PITCHER and T. BUTLER-JONES,
B.A. With an Introduction by Sir GEORGE
BEILBY, LL.D., F.R.S. Crown 8vo. Second
Edition. **6** - net

THE ENGINEER SERIES

BRITISH WIRE-DRAWING AND
WIRE-WORKING MACHINERY



THE ENGINEER SERIES

BRITISH WIRE-DRAWING AND WIRE-WORKING MACHINERY

BY

H. DUNELL, A.C.G.I., A.M.I.MECH.E., O.B.E.

(On the Editorial Staff of "The Engineer")

WITH A FOREWORD BY

SIR W. PETER RYLANDS

LONDON

CONSTABLE & COMPANY LTD

10 & 12 ORANGE STREET LEICESTER SQUARE WC 2

1925

PRINTED IN GREAT BRITAIN BY THE WHITEFRIARS PRESS, LTD.,
LONDON AND TONBRIDGE.

PREFACE

IN view of the fact that the wire-working industry of this country consumes, roughly, a quarter of a million tons of steel annually, and about half as much of the non-ferrous metals, while it involves the use of appliances ranging in their intricacy from the simple rolling mill to machinery which requires a magnifying glass for its adjustment, it is rather remarkable that no connected account dealing with the various ramifications of the trade has yet been published. In view of these circumstances, the Editor of *The Engineer* decided to publish the articles which are here issued in book form, with some slight additions consequent on later explorations.

At the outset it is obvious that the many ramifications of the wire trade could not be described in detail without making the series of articles of inordinate length, while there are many sections of the business where inquisitive strangers are very unwelcome, and concerning which it is correspondingly difficult to obtain information. It is hoped, however, that none of the important sections of the industry have been passed over too briefly in an endeavour to condense the matter, while, as regards the more secret processes, such as the making of safety pins, wire netting, chains, mattresses, etc., the writer was more fortunate than others in getting permission to utilise, in the articles in question, the results of explorations of the principal factories of this country concerned in their production.

In this connection it is noteworthy that while some of the manufacturers visited were uncommunicative, to the extent of refusing admittance at their threshold, others gave every assistance in their power. Thus, for instance, Mr. Goodman, of Birmingham, was at great pains to explain the whole process of safety-pin making, Mr. Doughty, of Tinsley, "gave away" several points about wire-rod rolling, Mr. Vincent, of Birmingham, exhibited the intricate process of making jewellery chains, and Mr. Rushworth, of Cleckheaton, had several machines specially erected and put to work to demonstrate their capabilities. Some other engineers who have helped very materially in the compilation of this work are Mr. Davies, who wrote the chapter on "Wire Flattening," Mr. Cargill, of Glasgow, who is largely responsible for the section dealing with wire weaving, and Mr. Noel Bedson, of Manchester, son of the veteran wire-drawing engineer.

This book is not intended to be theoretical or to give highly technical information in detail, neither does it cover some of the more simple branches of the trade. Take, for instance, that class of work carried out by the wire workers in making bird cages and so forth, which operations require considerable manual skill but little technical training, and are not of great interest to the engineer. The object in choosing the subjects for review has been rather to take those which involve the use of machinery and aim at the reduction of manual labour.

The wire industry is noted for its conservatism, and it is hoped that the publication of this information may help towards a greater interchange of knowledge among manufacturers, to the ultimate betterment of the trade.

H. D.

LONDON,
May, 1925.



CONTENTS

CHAPTER	PAGE
I. THE MANUFACTURE OF WIRE RODS	1
II. WIRE DRAWING	11
III. DIES	20
IV. WIRE-DRAWING BLOCKS	27
V. CONTINUOUS WIRE-DRAWING MACHINES	36
VI. STRAIGHTENING AND CUTTING-OFF MACHINES	49
VII. WIRE FACTORIES	59
VIII. WIRE-NETTING MACHINERY	72
IX. WIRE FACTORIES	82
X. WIRE-WEAVING LOOMS	90
XI. ELECTRIC CABLE MAKING	104
XII. HIGH-SPEED STRANDING MACHINES	117
XIII. BARBED WIRE MACHINES	124
XIV. NAIL AND RIVET MAKING MACHINES	131
XV. PIN-MAKING MACHINES	136
XVI. NEEDLE MAKING	141
XVII. SAFETY-PIN MAKING	150
XVIII. WIRE CHAIN MAKING	156
XIX. WIRE FLATTENING	166
XX. MISCELLANEOUS MACHINES	178
INDEX	187

LIST OF ILLUSTRATIONS

FIG.	PAGE.
1. The No. 2 Looping Wire Rod Mill at Tinsley	3
2. 1,800 Horse-power Engine driving No. 2 Rod Mill at Tinsley	4
3. Back of Pusher Furnace, No. 1 Mill	6
4. Front of Furnace, showing Drawing Doors	7
5. Plan of Morgan Continuous Wire-Rod Mill	8
6. Diagrammatic Section of Repeater Bar	9
7. Annealing Furnace—Barron and Crowther	12
8. Barco Annealing Pot	13
9. General Arrangement of Typical Wire-drawing Plant	14
10, 11. Pointing Rolls—G. Crossley	15
12. Pointing Furnace—G. Crossley	16
13. Pointing Machine—G. Crossley	17
14, 15. Rotary Swaging Machine—Sir J. Farmer, Norton and Co.	18
16. Breaking-down Die	20
17. Punch Grinding Machine—Barron and Crowther	21
18. Die-battering Machine—G. Crossley	22
19. Haley and Pinder Die-battering Machine—G. Crossley	23
20. Pneumatic Die-battering Machine—Alldays	24
21. Mechanism of Die-battering Machine	24
22. Diamond Die—T. Bolton	26
23. Single Wire-drawing Block—David Bridge	27
24. Single Block—Sir. J. Farmer	28
25. Steel-framed Machine—Barron and Crowther	29
26. Block with Internal Gear Drive—Barron and Crowther	30
27. Heavy Wire-drawing Block with Friction Drive—G. Crossley	30
28. Heavy, Thick Wire-drawing Blocks with Capstan Pull-in—G. Crossley	31
29, 30. Single-sided and Double-sided Wire-drawing Frames—G. Crossley	32
31. 12-inch dia. Wire-drawing Blocks—G. Crossley	33
32. Eight-block Wire-drawing Bench—Wm. Grice	34
33. Three-hole Continuous Machine—Barron and Crowther	36
34. Four-hole Continuous Block—Barron and Crowther	37
35. Two-hole Continuous Machine—G. Crossley	38
36. Three-hole Wet-drawing Machine—G. Crossley	38
37. Two-hole Continuous Wire-drawing Machine—G. Crossley	39
38. Nine-hole Continuous Wire-drawing Machine—W. H. A. Robertson	40
39. Stringing-up Machine—Roberston	41
40. Vertical-roll Continuous Wire-drawing Machine—David Bridge	42
41. Seven-hole Continuous Machine—G. Hattersley	43
42. Chain-driven Continuous Wire-drawing Machine—G. Hattersley	44
43. Continuous Machine for Fine Wires—Robertson	45

LIST OF ILLUSTRATIONS

FIG.	PAGE.
44. Continuous Wire-drawing Machine—David Bridge	47
45. Continuous Machine for Very Fine Wires—Robertson	48
46. Straightening and Cutting-off Machine—G. Crossley	49
47. Roll Type Straightener—G. Crossley	50
48. Machine for Cutting Heavy Wire—G. Crossley	51
49. Machine for Cutting Two Wires Simultaneously—G. Crossley	52
50, 51. Continuous-feed Straightening and Cutting-off Machine—J. Thompson	53
52. Continuous-feed Cutting-off Machine—J. Thompson	54
53. Roll-feed Straightening and Cutting-off Machine—A. Robinson	55
54. High-speed Straightening and Cutting-off Machine—E. White	56
55. Small Straightening and Cutting-off Machine—W. Grice	57
56. The First Continuous Wire Rod Mill	59
57. No. 2 Continuous Rod Mill at Bradford Ironworks	60
58. General View of No. 5 Mill at Bradford Ironworks	61
59. General Arrangement of No. 5 Rod Mill	62
60. Looping Slope of No. 5 Rod Mill	63
61. 2,750 Horse-power Roughing Mill Motor	64
62. Wire Patenting Frame	65
63. Wire Rod Cleaning Department	65
64. Heavy Wire-drawing Department	66
65. Part of the Galvanising Department	66
66. Plan of the Bradford Ironworks	<i>to face</i> 66
67. Barbed Wire Department	67
68. Fine Copper Wire Shop	67
69. Heavy Copper Wire Shop	68
70, 71. Variable-speed Drive for Patenting Frame	69
72. Wire Galvanising Frame	70
73. Heavy Blocks in Wire-drawing Shop	72
74. Light Wire-drawing Blocks	73
75. (Wire Netting)	74
76. (Wire Netting)	75
77. (Wire Netting)	75
78. Galvanising Wire Netting	76
79. Tight-winding Netting for Export	76
80. (Wire Netting)	77
81. (Wire Netting)	78
82. Spring-winding Shop	79
83. Wire Netting Weaving Shop	80
84. Heavy Wire-drawing Mill	82
85. Mill for Continuous Drawing through Three Holes	83
86. Wet Mill for Continuous Drawing of Fine Wire	84
87. Making Springs for Wire Netting	84
88. Small Wire Netting Looms	85
89. Galvanising Wire Netting	85
90. Barbed Wire Shop	86
91. Wire Rope Department	87

LIST OF ILLUSTRATIONS

FIG.		PAGE.
92.	Nail-making Shop	88
93.	Wire-flattening Department	88
94.	Flying-shuttle Wire-weaving Loom—Anderston	90
95.	Positive-action Wire-weaving Loom—McGee	91
96.	Warp-beam Winder and Bobbin Creel—Anderston	93
97.	(Wire Weaving)	94
98.	(Wire Weaving)	94
99.	High-speed Over-pick Loom—Anderston	95
100.	(Wire Weaving)	96
101.	Heavy Automatic Loom—Anderston	96
102.	Heavy Semi-automatic Loom—Anderston	97
103.	Crimping Machine—Robertson	98
104.	(Wire Weaving)	98
	A Row of McGee Wire-weaving Looms in Messrs. Richard Johnson's Works	99
	Bobbin-winding Department in Messrs. Richard Johnson's Works	101
105.	Heavy Bar Loom—R. Johnson	102
106.	Wire-weaving Loom—Hattersley	103
107.	High-speed Triple Automatic Wire Winder—Johnson and Phillips	104
108.	High-speed Strander—Johnson and Phillips	106
109.	Large Triple Bobbin-winding Machine—Johnson and Phillips	107
110.	Small Triple Bobbin-winder—Johnson and Phillips	108
111.	Six-bobbin Strander	109
112.	Twelve-bobbin Strander—Johnson and Phillips	110
113.	Double-tandem Strander	111
114.	Large Triple-tandem Strander	111
115.	Three or Four Bobbin Closing Machine—Johnson and Phillips	112
116.	Seventy-two-bobbin Wire Cable Armouring Machine—Johnson and Phillips	113
117.	Large Cable-making Machine with Eighteen Large Bobbins in Use	114
118.	Rear, or Inlet, End of Cable-making Machine	114
119.	Front End of Machine with Taping and Servicing Units in Foreground	115
120.	Seven-bobbin 6½ inch dia. Stranding Machine—Larmuth	118
121.	Eight-bobbin 24-inch dia. Closing Machine	118
122.	Seven-bobbin Stranding Machine with Guards and Lifting Trolley	119
123.	Eighteen-bobbin Stranding Machine	119
124.	Hand-turning Gear	120
125.	Six-core Laying-up Machine with Forty-eight-bobbin Paper Lapper and Copper Taping Gear	121
126.	Six-core Laying-up Machine with Forty-eight-bobbin Paper Lapper and Copper Taping Gear	122
127.	Glidden Barbed Fencing Wire	124
128.	Barbed Wire Machine—J. Hetherington and Sons	125
129.	(Barbed Wire)	126
130.	(Barbed Wire)	127
131.	Barbed Wire Machine—Richard Johnson and Nephew	129
132, 133.	Wire Nail-making Machine—W. Grice	132
134.	Nail-pointing Dies	133

LIST OF ILLUSTRATIONS

FIG.	PAGE
135. Rivet-making Machine	134
136. Battery of Five Pin-making Machines—E. White	136
137. Automatic Pin-making Machine—E. White	137
138. Pin-sticking Machine—E. White	139
139. (Needle Making)	141
140. Needle-pointing Machine—E. White	142
141. Pointing Machine for Long Needles—E. White	142
142. (Needle Making)	143
143. Skimming Machine—E. White	144
144. Stamping Machine—E. White	145
145. Automatic Eyeing Machine	147
146. Combined Stamping and Eyeing Machine	147
147. Automatic Head Grinding Machine	147
148. Scouring Mill—E. White	149
149. Assorting Machine—E. White	149
150. Diagram of Safety-pin Pointing Machine	151
151. Diagram of Goodman's Safety-pin Forming Machine	152
152. Head-forming Tools	153
153. Trace Chain-making Machine	157
154. Curb Chain Machine with Top Twister	158
155. Diagram of Trace Chain-making Machine Mechanism	158
156. Chuck Mechanism	159
157. Curb Chain-making Machine Mechanism	160
158. Four Stages in Making Knotted Chain	161
159. Diagram of Knotted Chain Machine	163
160. Feed Gear	164
161. Folding Tools	164
162. (Wire Flattening)	166
163. General Arrangement of Wire Flattening Mill	168
164. Edging Rolls	168
165. 9 inch by 6 inch Wire Flattening Mill	169
166. Single Coiling Stand	170
167. Heavy Coiling Stand	170
168. Straightening Head	171
169. Mill with Edging Rolls	172
170. Mill with Separate Adjustment for Bearings	173
171. Small Flattening Mill for Four Wires	174
172, 173. Tandem Two-pass Mill with Edging Rolls	175
174. Mill Fitted with Roller Bearings	176
175. Stages in the Making of Paper Clips	178
176. Hand-bowing Machine	179
177. Paper-clip Making Machine—E. White	179
178. Hairpin-making Machine—E. White	181
179. Double Helical Gear for Wire Flattening Machines	182
180, 181. Spring-coiling Shops of Herbert Terry and Sons	183

FOREWORD

The Engineer has done a great service by making a substantial contribution to the slender literature which exists on the subject of wire and wire manufacture. Few, if any, iron and steel commodities enter more intimately into the satisfaction of our daily needs than wire. It is possible that not many people realise the wide ramifications of its application.

We are all familiar with the use of wire for fencing and telegraph purposes, but, in addition, there are countless forms in which it is employed, ranging from ladies' dresses, where it is found in hooks and eyes, pins, corsets, hats and artificial flowers, to its widespread use in the house in nails, bell wires and picture cord, and springs in chairs and mattresses. In addition wire finds an important outlet in various branches of engineering in the manufacture of wire rope, bolts and pinions.

The industry has grown to vast importance during the past century, and the world's consumption of wire nails alone cannot fall far short of 1,000,000 tons a year. There have been substantial developments in the manufacture of wire in this country, and *The Engineer* has performed a useful work in providing an account of the industry, and testifying to the efficiency of British manufacture.

It is a matter of regret that the development of the industry in this country has not been commensurate with its growth in the United States and on the Continent, where it has been regarded rather as a vehicle for the disposition of a large steel production, and is associated with, and fostered by, the steel industry from that point of view, while in this country the industry is of old standing and is carried on largely as detached from the heavy steel trade.

The common classes of wire have for long been a dumped product, frequently assisted by actual bounties upon exports, with the result that the big tonnage trade has been largely lost to this country, British manufacturers specialising in quality, the reputation of the British product standing high in all the markets of the world.

It is probable that this book will be widely read by those technically interested, but the process of wire drawing has never ceased to fill me with wonderment, even after my long association with the industry. A piece of steel looks such a hard and unyielding substance, and it is amazing that it can be squeezed down cold like a piece of putty and elongated by this process thirty times its initial length without heat treatment of any kind.

The Editor of *The Engineer* is to be congratulated upon this production, which I am satisfied will provide a valuable text-book for the industry.

W. PETER RYLANDS.

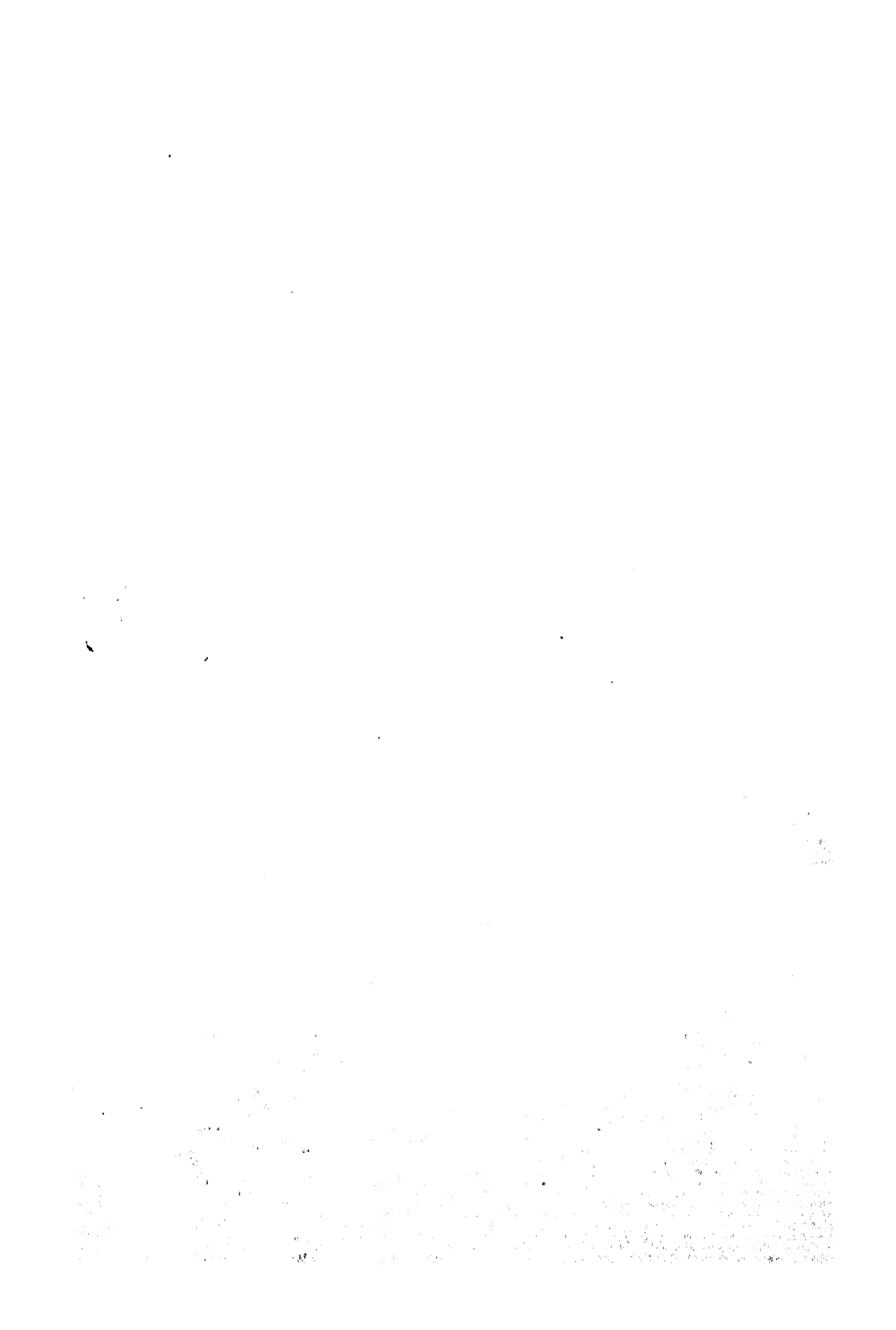

BRITISH WIRE-DRAWING AND WIRE-WORKING MACHINERY

CHAPTER I

THE MANUFACTURE OF WIRE RODS

INTRODUCTORY

THE subject of wire working naturally divides itself up into two distinct sections, the first being concerned with the production of the wire and the second with its conversion into a wide variety of useful objects.

In connection with the first section, it is not proposed to go into the history of the industry to any extent, as it has been dealt with by several writers ; but it is noteworthy that although the use of wire is referred to in some of the earliest writings, the modern system of wire drawing is of quite recent introduction. In Biblical days wire was made by cutting sheet metal into strips and hammering them on an anvil to reduce them to the required thinness. Obviously, only short lengths could be produced by this process.

There are some brief references to the drawing of wire through a die, instead of hammering it, which date back 900 or 1,000 years, while it appears that there were some wire-drawing establishments in Paris in the latter half of the thirteenth century. It is generally conceded, however, that wire drawing, as an important industry, only started about the year 1350 on the Continent, and that it was not introduced into England until the reign of Queen Elizabeth.

The substitution of rolled rods for hammered rods greatly facilitated the process of wire drawing, but it was only about fifty years ago that a continuous wire-drawing machine was evolved by Mr. A. Thornton, of Manchester. Since that time various improvements have been made in the machines, but they still possess the same general characteristics. It is satisfactory to note that although continental industrialists played such a prominent part in the early history of the industry, it was an English inventor who made one of the most important steps in its development.

As to machines for working up wire into useful articles of commerce, there is not much historical information ; but there are still in service, machines which were used at the time of the Crimean War for making military accoutrements from wire, while Queen Elizabeth possessed a factory for making pins from wire. Nowadays there are vast numbers of machines for working up wire, ranging from the delicate apparatus used in fashioning needles to massive looms making wire mesh from material $\frac{1}{4}$ in. in diameter.

Before describing the process of wire drawing, it may be as well to make some reference to the raw material from which the wire is drawn.

Since very little iron wire is now made, wire may be roughly classified as steel or non-ferrous. The preparatory processes for the two classes are generally distinct,

BRITISH WIRE-DRAWING AND WIRE-WORKING MACHINERY

although with some non-ferrous metals, such as the nickel alloys and copper, there is a close resemblance to the practice with steel.

The rods from which brass wire is drawn are generally produced by slitting flat bars. The bars are passed between rolls provided with sharp-edged grooves that shear the metal into long square section strips. The work requires considerable skill and attention on the part of the men in guiding the bars through the rolls, but even with care a large amount of scrap is produced through the strips tapering away or breaking off into short unusable lengths. The square strips are passed through rolls to round them off and reduce their section somewhat, and are then passed on to the annealing and drawing departments.

STEEL WIRE ROD

For the production of the rods used in making steel wire much more elaborate equipment is the rule.

The billets from which the rods are rolled are generally brought from outside, and it is not proposed to pursue the subject further back than the arrival of the billet at the mill, as it appears that most works rely on the experience of the steel makers for the quality of the material, although many modern mills systematically analyse samples of the steel they use. It appears, in fact, that the quality of the ultimate product is as much dependent on the treatment the metal receives in rolling and drawing, as on the chemical composition of the metal itself, although it is obvious that good wire cannot be made from bad billets.

Three types of wire rod rolling mill are in vogue in this country, and a typical example of each of the three is to be found in the works of Wm. Cooke and Co., Limited, Tinsley, near Sheffield, and the associated Templeborough Rolling Mills Company, Limited.

The first of the three styles of mill just mentioned comprises a set of rolls, generally all coupled in line, through which the billet is passed in succession, being man-handled between each pass; but, on account of the large amount of labour involved in working by this system, it is being rapidly superseded by more modern methods, and it is not necessary to enlarge upon it here.

The looping mill, which comes next in date of origin, was first developed in Belgium, and effects a great saving of labour. The looping, or No. 2, mill at Messrs. Cooke's, which is illustrated by the accompanying engraving, Fig. 1, comprises three distinct trains of rolls all driven by ropes from a fine cross-compound Marshall steam engine of about 1,800 horse-power—see Fig. 2. In this connection it is noteworthy that it is very important that the speed of the drive should be kept as nearly uniform as possible, as variations may affect the quality of the rod on account of differences in the temperature as it passes through the rolls. There is a steam recorder in the engine-room, and the stokers are urged to maintain as constant a steam pressure as possible.

The three trains of rolls comprise a cogging mill, an intermediate set and a finishing mill.

The cogging mill does not require much comment, as it follows ordinary mill practice. In it billets about 3 in. square are rolled down to about $1\frac{1}{4}$ in. square, and they are then passed directly by hand to the intermediate mill. The intermediate rolls are two-high, and the rod is generally given two passes here, but it is not handled in the process. Directly behind the groove in the roll, through which the bar passes, there is a "repeater," or curved guide that leads the rod into the next pass.

The two successive pairs of rolls run at the same peripheral speed, but the rod is

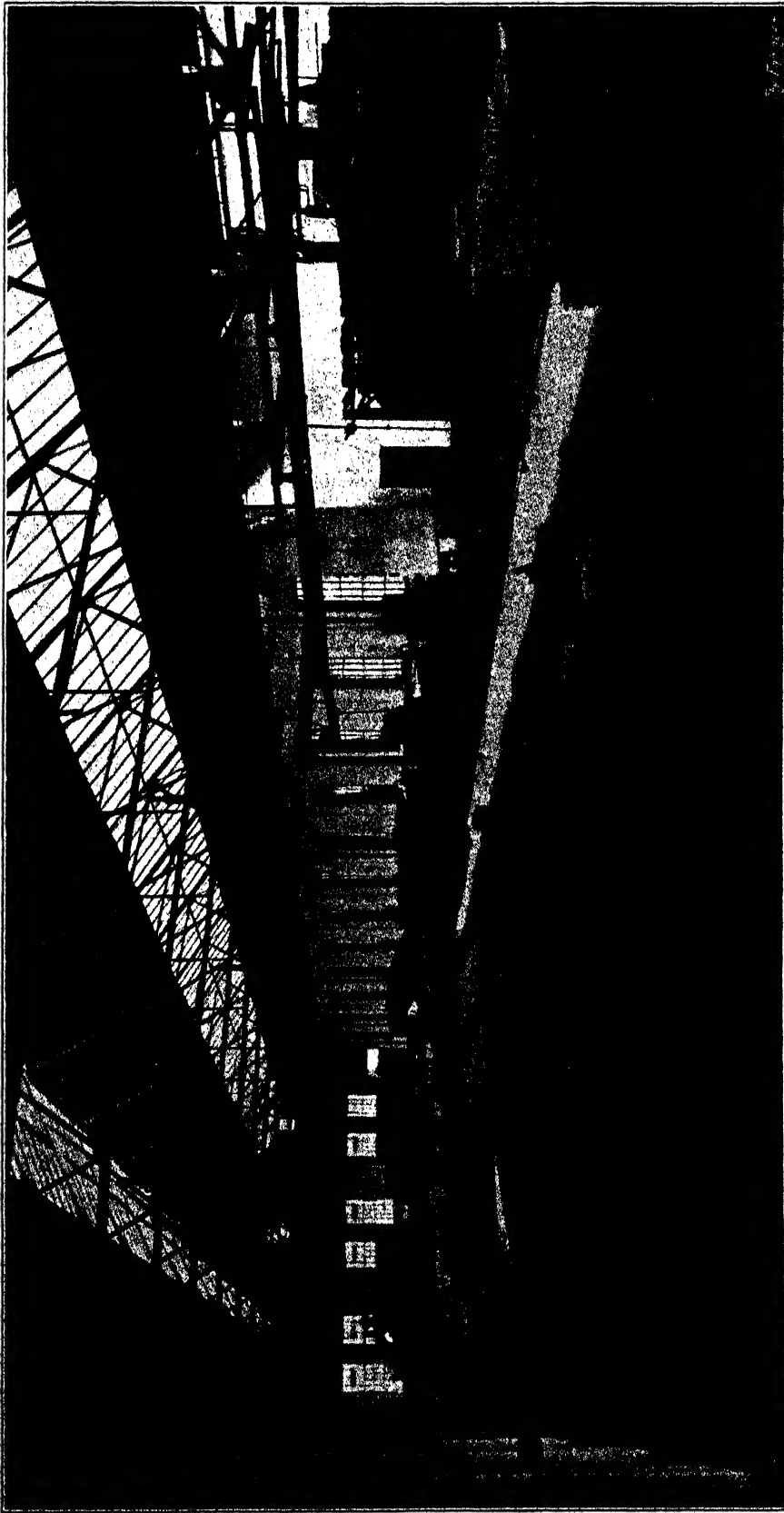

FIG. 1.—THE NO. 2 LOOPING WIRE ROD MILL AT TINSLEY.

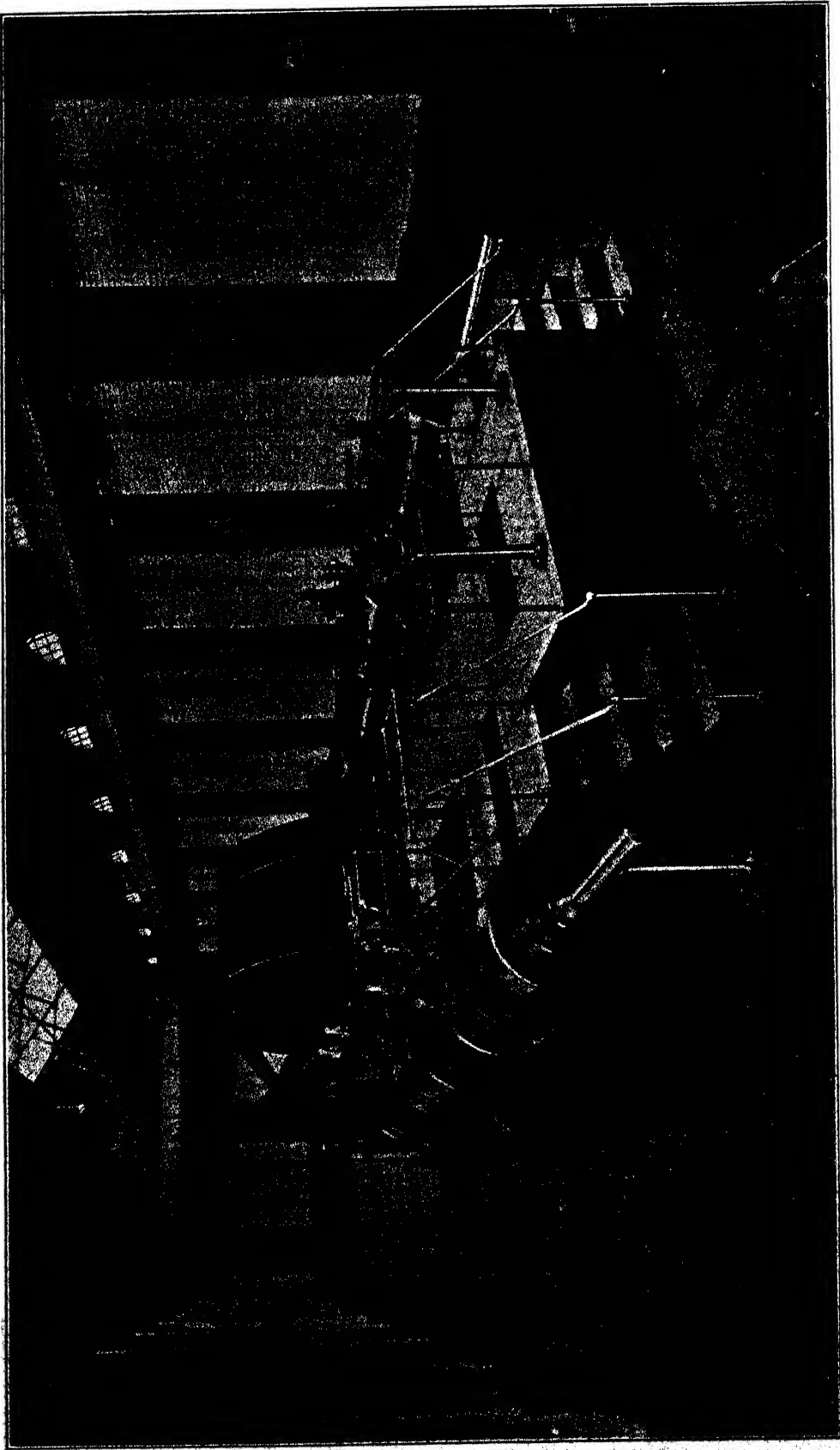

FIG. 2.—1,800 HORSE-POWER ENGINE DRIVING NO. 2 ROD MILL AT TINSLEY.

THE MANUFACTURE OF WIRE RODS

naturally lengthened as it goes from pass to pass. In other words, the rod must emerge from the rolls at a greater lineal speed than it is drawn in, as it not only takes up the speed of the rolls themselves, but is also squeezed forward by an amount corresponding with the reduction in cross-sectional area. As a result, a greater length of rod is fed out from the first pass, in a given length of time, than is drawn in by the second pass. This increase in length could not be accommodated in the repeater if it were a closed duct, so the bottom side—it is square in cross section—is left open, and as soon as the rod coming from the first pass begins to crowd up against the second pass, it jumps out of the repeater through the opening and extends as a loop on the floor. When the back end of the rod comes out of the first pass, the loop trails round an iron stump or fair lead in the floor so that the end is guided towards the second pass.

From the intermediate rolls the rod is guided into the finishing mill, and here, again, no attendant is required. The repeater in this case, however, takes the form of a plain closed pipe, as no extending loop is allowed to accumulate. The two mills are driven separately, and the peripheral speeds of the two sets are so adjusted as to take up all the slack of the rod as it is produced. From this point onwards the rod is taken from pass to pass by hand, and it is surprising how dextrous the men become in snatching the end of the rod, in tongs, immediately it appears through the rolls and entering it in the guides of the next pass.

There is a very considerable extension of the rod at each passage through the finishing rolls, and the resulting loop is accommodated in long troughs, which extend as inclines below the floor plates. The rod, in fact, becomes so long that it is frequently being worked upon simultaneously by three pairs of rolls.

After going through the last pass, the rod, now about $\frac{3}{16}$ in. or $\frac{1}{4}$ in. in diameter, is taken to a coiling machine, and wound on a horizontal swift. This machine is driven by a variable-speed electric motor, so that the attendant can just keep pace with the mill and not stretch the rod in coiling it up; but generally there is ample slack on the floor to obviate such an occurrence. When the rod emerges from the finishing train the end is caught in a hook by a boy, and he guides it on the floor in big figures of eight, just as if he were a gardener watering the lawn with a hose, and it is not until several loops have accumulated that the first end is taken to the coiling machine. Just as the last end of the rod emerges from the mill, an attendant chops off the end with a big hatchet for sampling purposes. The coils are pulled off the winder by hand, and are hauled away to cool down before being sent to the stock yard.

The speed of these mills is really astonishing to any one used only to heavy rolling mill practice, as they run at a speed of some 400 revolutions per minute, and have a peripheral speed of from 1,200 ft. to 1,300 ft. per minute. The result is, as has just been suggested, that the rod is projected from the mill just like a stream of red-hot water.

This high speed is an important factor in the operation of the mill, as it not only increases the output, but also has a great bearing on the uniformity of the rod throughout its length. The back end of the rod has, of course, been longer out of the furnace than the front end, when it goes through the last pass, and as a consequence is not rolled quite so small. The difference in finishing temperature also has an effect on the physical characteristics of the rod, which is found to increase gradually in hardness from the beginning to the end of the coil. The maximum stress of the material at the end of the rod may be as much as $1\frac{1}{2}$ per cent. greater than that at the beginning, while the elongation on fracture is correspondingly reduced. This variation in quality may appear to be slight, and can be eliminated by subsequent normalising, but it is

BRITISH WIRE-DRAWING AND WIRE-WORKING MACHINERY

in the interests of the rod maker, from all points of view, to keep the speed of rolling as high as possible.

The wear and tear on rolls subjected to such service as that just described is naturally severe, and they have to be made of the very best material. Some are of cast steel, but chilled cast iron seems to be preferred. The diameter ranges about 12 in., and the length is approximately the same. Each roll is provided with several grooves, all of the same size, so that they can be used in succession, as they wear out, without it being necessary to change the rolls.

In the course of reducing round sections by rolling it is not, of course, possible to maintain a round section throughout the several passes, as such a process would only result in fins being squeezed out on either side, and these fins would subsequently be bent over and form "cold shuts" in the rod. It is consequently necessary to vary the shape of cross section from pass to pass. The actual variations depend on the rate

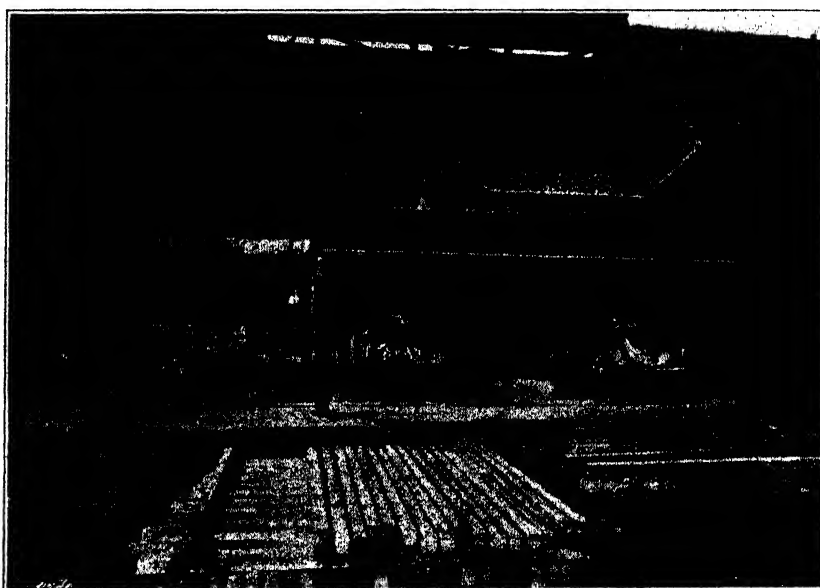

FIG. 3.—BACK OF PUSHER FURNACE, No. 1 MILL.

of reduction in area required, but generally they comprise combinations of squares, ovals and rounds in sequence, naturally finishing with a round.

The change in the section of the rod during the finishing pass gives the roller a good opportunity of judging, at a glance, the accuracy with which the rolls are set. In this last pass an oval is converted into a round, and the rod may have flattened sides, or have fins, according as to whether too much or too little is delivered to the finishing rolls from the previous pass. The adjustments in this direction are very important, as the wire drawer naturally wants to be supplied with round rods, while, unless the rod is worked upon by the rolls equally all round its circumference, there will be hard and soft spots in its cross section.

The rod has to be offered up to the groove of each pass very precisely—as an oval, for instance, must not lie on its side as it enters a round groove. As a consequence, the guides have to reach right up between the rolls and terminate in a fine point, so that the rod is supported as close to the rolls as is possible. Any damage to the point of the guide is fatal to its proper working. The guides are fixed between the

THE MANUFACTURE OF WIRE RODS

housings in the usual manner adopted in rolling mills, and are adjusted by means of wedges.

The rods generally turned out from the Tinsley works are of No. 5 gauge, or about 0.22 in. in diameter, which appears to be the most favourite size among wire drawers.



FIG. 4.—FRONT OF FURNACE, SHOWING DRAWING DOORS.

The output of the mill just described, together with the older No. 1 mill, is some 60 tons per ten hours' shift. Figs. 3 and 4 illustrate a new pusher furnace for heating billets installed in the No. 1 mill by the Harvey Siemens Furnace Company.

CONTINUOUS MILLS

The third class of wire rod rolling mill is the continuous type developed in America by Morgan, the principle of which was invented in Manchester by George Bedson as long ago as 1862. A very full description of the Morgan equipment of the Templeborough Rolling Mills, Limited, appeared in *The Engineer* of June 20th, 1919, but it may be as well to give here an outline of the scheme, as it results in such a great increase in output without involving any heavy manual labour. The general arrangement of the mill is given in Fig. 5.

In the Morgan system of rolling, the sets of rolls, instead of being arranged in a long line, lie parallel with one another and are close together, so that the rod goes directly from one pair of rolls to the next. In order to accommodate the increase in the length of the rod, as it is reduced in section, each pair of rolls is driven at an appropriate speed. The drive is taken from a common shaft through bevel gearing, but each set of gears has a different ratio. By adopting this arrangement, it is possible to roll the rod at a very high speed, and it goes through the final pass at a rate of some 2,800 ft. per minute.

The arrangements for reducing manual labour are very elaborate, and although several attendants are required, they are not called upon to do any really hard work. The billets, which, by the way, are much thinner than those used at the looping mill,

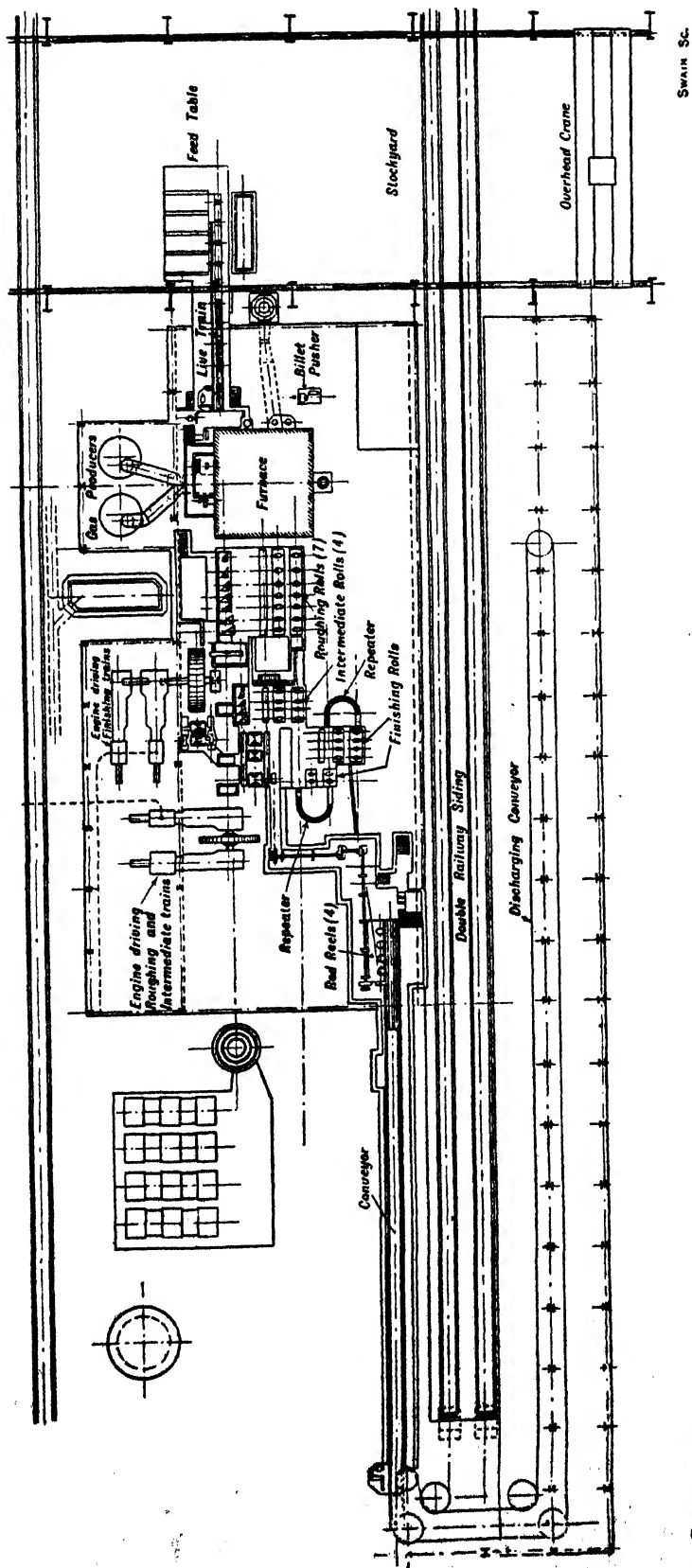

FIG. 5.—PLAN OF MORGAN CONTINUOUS WIRE-ROD MILL.

THE MANUFACTURE OF WIRE RODS

being 30 ft. long by $1\frac{1}{2}$ in. square, are fed into the furnace by live rollers, and are pushed out again, when heated, by a machine. In this connection, it is noteworthy that all instructions in the mill—such as those to the man in charge of the billet pusher—have to be given by blasts on a steam whistle, as the machinery makes so much noise that conversation is impossible.

Each billet is pushed out of the furnace directly into the first pair of a train of seven roughing rolls. There are two grooves in these rolls, so that so soon as one billet is clear of the furnace, another can be fed into the second set of grooves without interfering with the progress of the first, and the capacity of the mill is virtually doubled by working, as the expression is, "double strand." The space between the furnace door and the first roll is a matter of only a foot or so, and in this space there is a set of toggle shears which can be used to cut off the billet in the event of any mishap in the mill. From the roughing train the rod goes to the intermediate rolls, four in number, and driven by the same engine. Between the two units there is a set of flying shears, which is used to snip off the end of the bar as it passes, in order to give it a good clean end for entering the next pass. These shears can, of course, also be used to sever a defective or damaged bar.

From the intermediate rolls, the bar goes to the finishing set, of which there are six stands, arranged in two groups, of two and four pairs of rolls. The finishing train is not in line with the intermediate set, and the rod is guided into it by a repeater of a different pattern from that already described in connection with the looping mill. This repeater—see Fig. 6—is open at the top and on the inside of the curve, but is provided with two undercut grooves for guiding the rod, which jumps out at the top of the repeater and can extend, as a loop, up and down a long incline.

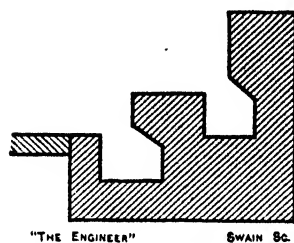

FIG. 6.—DIAGRAMMATIC SECTION OF REPEATER BAR.

The reason for introducing this repeater is the fact that there are two engines for driving the mill. One, of 1,700 horse-power, works the roughing and intermediate rolls, while another, of 1,100 horse-power, drives the finishing train. Both engines are by Yates and Thom. It should be mentioned, incidentally, that steam engines were installed at Templeborough as a war-time expedient. Normally, mills of this type are driven by electric motors, and there seems to be a general tendency to adopt that form of drive in all machinery connected with wire working. If it so happens that the two engines are not adjusted to run exactly in unison, the rod will be rolled more, or less, quickly in one set of the rolls than in the other, but any difference in the rate of feed is taken up in the loop formed by the repeater. Generally speaking, however, the rod hardly leaves the guiding groove of the repeater. Another similar device turns the rod back again and leads it into the final set of four finishing rolls, from which it goes to an automatic reeling machine, and is taken away by a conveyor on which the coils cool down sufficiently to be loaded into railway trucks.

At the time when the author visited the Templeborough mill, No. 5 gauge wire rod was being rolled, and it took just 50 seconds to complete a coil of 300 lb., while the consistent output was 120 coils per hour—the mill was working double strand.

The rods produced by the Morgan mill have an appearance slightly different from those made by the ordinary rolling mill, as the mill scale on them seems to be more adherent, a peculiarity which is to be accounted for by the greater amount of handling which the ordinary rods receive, as compared with the rapid and uniform progress through the Morgan mill. Inquiry among wire drawers did not show that special

BRITISH WIRE-DRAWING AND WIRE-WORKING MACHINERY

favour for one rod or the other exists, although it was admitted that the smaller amount of scale on the ordinary rod facilitates pickling. Another slight difference between the two classes of rods is the lesser variation in the hardness from end to end of the Morgan rods, a characteristic easily accounted for by the higher speed of rolling.

The great extent of the wire rod rolling industry may be gauged from the fact that the one firm of Wm. Cooke and Co., Limited, alone produced 40,000 tons of rods per month during the comparatively quiet times of 1922-23.

CHAPTER II

WIRE DRAWING

IN the previous chapter a short description was given of the process of making the rods which are subsequently drawn down to form wires, and it was pointed out they are generally from $\frac{3}{16}$ in. to $\frac{1}{4}$ in. in diameter, round in the case of steel, and square with rounded corners for most alloys. From these raw materials wires of a remarkable fineness are regularly drawn. Thus the smallest commercial size in low or medium-carbon steel is 0.0025 in. in diameter, while hard-steel music wire is drawn down to 0.005 in. diameter. Copper can be reduced to 0.001 in., and nickel silver and pure iron to 0.002 in. The very finest wire made is of platinum, 0.00003 in. in diameter, but it is not produced by a simple drawing action. The platinum is encased in silver to bring it up to a workable size, and this silver is subsequently dissolved away. Another rather fine example of wire drawing was carried out at the Glasgow Exhibition, when a single piece of copper wire over 100 miles in length, but with a weight of only 11 lb., was produced. It took forty hours to run the wire through the machine. Two other fine examples of wire drawing in copper were exhibited at the British Empire Exhibition. One was a coil of $\frac{1}{8}$ in. wire, $7\frac{1}{2}$ miles long, in a single piece, weighing 2,120 lb., while the second was a spool of No. 47 gauge, which weighed only $16\frac{1}{2}$ oz., but contained 20 miles of wire without a joint.

The process of reducing the size of a piece of metal, by forcibly pulling it through the contracting orifice of a die, to the extent indicated by the foregoing notes, must obviously change its physical properties very considerably, and it may be as well to give here some consideration to this aspect of the industry. The subject has been dealt with at considerable length by several authors, notably by J. D. Brunton, *Journal of the West of Scotland Iron and Steel Institute*, 1900; J. D. Brunton, *Journal of the Iron and Steel Institute*, 1906; P. Longmuir, *Journal of the Iron and Steel Institute*, 1912; and by Dr. F. Johnson in a lecture before the Birmingham Local Section of the Institute of Metals. The following notes are largely based on those writings.

ANNEALING

There seems to be some difference of opinion among wire drawers as to the necessity for annealing rods before they are sent to the draw bench, and this difference may be accounted for by the relative importance attached to the variations in the characteristics of the rod at different parts of its length, to which reference has already been made. Mr. Longmuir found, for instance, that even when special efforts were taken to ensure uniform conditions in rolling a rod over 1,000 ft. long, the maximum tensile strength at the beginning of the coil was 47.6 tons per square inch, with an elongation of 14.7 per cent. in 2 in., while at the end of the coil the corresponding figures were 50.6 and 13.6 respectively. If such a rod be subjected to the cold-working of drawing through a die, without first being annealed, he suggests that the process will fix the "habit" of the metal, which will persist through subsequent annealing stages, with the result that the final wire will lack uniformity.

In such cases the wire drawer is apt to blame the steel maker for the bad quality

BRITISH WIRE-DRAWING AND WIRE-WORKING MACHINERY

of the wire, whereas if he would anneal his rods before drawing, the trouble would probably be overcome.

Annealing is effected in much the same manner as in ordinary engineering practice. The coils are put into cast-iron pots, the lids of which are luted on. The pots are then heated up to redness and allowed to cool again before being opened. On the Continent a special furnace for annealing is somewhat in vogue. In it the wire is gradually heated to a temperature of 850 deg. in a closed retort filled with inert gas. The temperature is then allowed to fall slowly to about 100 deg. before the wire is taken out. Wire thus annealed is said to be ready immediately for further drawing.

Barron and Crowther, of Preston, make the special furnace and annealing pot shown in Figs. 7 and 8. The pot, it will be seen, has two lids 5 and 6, the lower one of which is formed as a tray for holding charcoal. The wire to be annealed is put into the light container 7, which is made of steel plate about No. 16 S.W.G. thick,

together with a few pieces of charcoal. The lids are then put in place, the top one pegged down and the pot put in the furnace. When the wire is annealed the pot is taken out of the furnace as quickly as possible, and a flexible metallic tube 2 used to connect it up with the gas service. The connection is made by means of a weight 3 and cone joint 4. The gas fills the space between the lids, and is kept on until the charge cools down. As it issues from the outlet 1, it is lighted to give an indication that the space below is filled with gas. In this way oxidation of the wire is prevented, and it comes out quite bright, ready to go to the drawing block. This arrangement is specially valuable when drawing hard

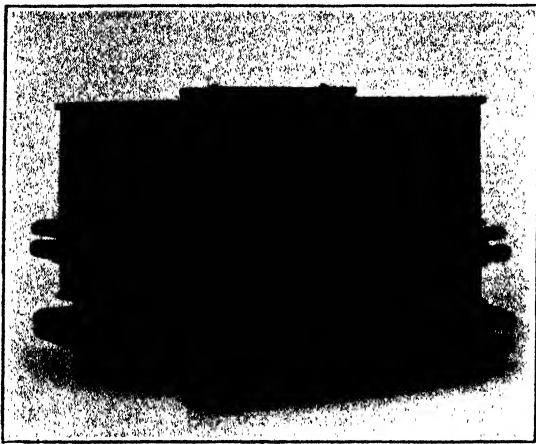

FIG. 7.—ANNEALING FURNACE—BARRON AND CROWTHER.

metal, such as stainless steel—which must be annealed several times during the drawing process—as it eliminates the loss from scaling.

Mr. J. D. Brunton made some extensive experiments on the effect of annealing rods before they were drawn, and communicated the results to the Iron and Steel Institute in 1906. Using a steel wire rod, hot rolled, containing 0.75 per cent. carbon, he found a maximum stress of 52.5 tons per square inch, and an elongation of 15.3 per cent. in 8 in. The rod would stand twenty torsions in 100 diameters. After being annealed for two hours in a close oven—without the flame touching the material—at a final temperature of 765 deg. Cent., and then allowed to cool slowly, the maximum stress was reduced to 47.3 tons, while the elongation was increased to 22.25 per cent., and the torsions to twenty-three. It is noteworthy, also, that annealing reduced the specific gravity from 7.753 to 7.748.

After cleaning to free them from scale, a process referred to later, and preparation for drawing, the two samples had the following characteristics:—

	Plain rod.	Annealed rod.
Maximum stress, tons per square inch	48.1	47.4
Elongation in 8 in., per cent.	14	24
Torsion in 100 diameters	15	34
Specific gravity	7.754	7.748

WIRE DRAWING

The samples were then drawn at a speed of 142 ft. per minute, and a reduction of 7 per cent., with the following results :—

	Plain rod.	Annealed rod.
Maximum stress, tons per square inch	62.6	56.9
Elongation, per cent.	7	6
Torsion	13	20
Specific gravity	7.770	7.760

A second annealing at a temperature of 890 deg. Cent. was then carried out, and new tests showed :—

	Plain rod.	Annealed rod.
Maximum stress, tons per square inch	62.1	61.4
Elongation, per cent.	15	17
Torsion	42	42
Specific gravity	7.750	7.749

After a final pickling, the two samples were drawn down through seventeen passes, during which the maximum stress steadily increased to 152 tons per square inch in the case of the untreated bar and to 165 tons for the annealed bar. The elongation and resistance to torsion varied erratically during the reduction of the wire, but there was a noticeable decrease in both towards the end of the drawing. One of the most striking features was, however, a sudden drop in the specific gravity after the last pass, following a steady increase up to that point. The maximum density attained was 7.998 sp.g., and the next pass produced a reduction to 7.997, which shows, according to Mr. Brunton, that it is impossible to increase the density beyond the larger figure by pulling the metal through a die. He also says that these experiments show that "annealing the rod before the final annealing does not, in any way, produce better material, as it has been thought to do, and is therefore not necessary."

PATENTING, ETC.

On the other hand, the character of the final wire can be very materially affected by the heat treatment which the material receives in the course of drawing, and steel wire is habitually subjected to the processes of "patenting" and tempering at one period or another during its reduction from the original rod. "Patenting" is a term used in the wire-drawing trade to describe a process somewhat akin to annealing, which aims at leaving the material in the sorbitic state. Different manufacturers have different methods of patenting, but the process may be generally described as heating the wire to such a temperature that the carbon and the iron in the steel become homogeneous throughout, and perfect inter-diffusion of the carbon and iron is effected. When in this condition the wire is cooled down sufficiently rapidly and the condition is retained. Patenting temperatures generally range from about 550 deg. to 700 deg. Cent., but sometimes the

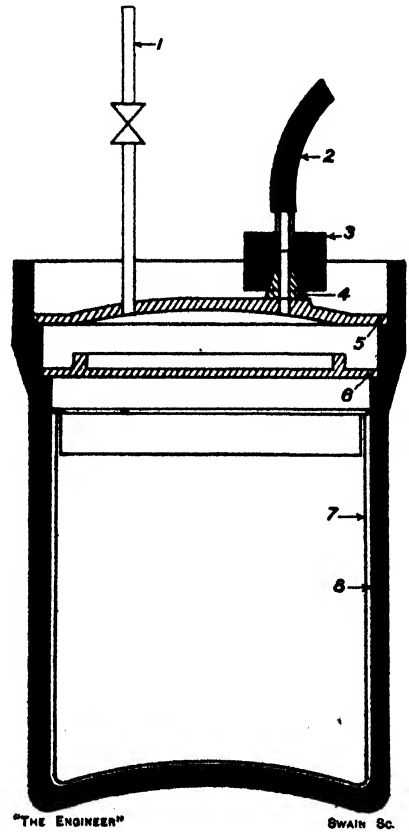

FIG. 8.—BARCO ANNEALING POT.

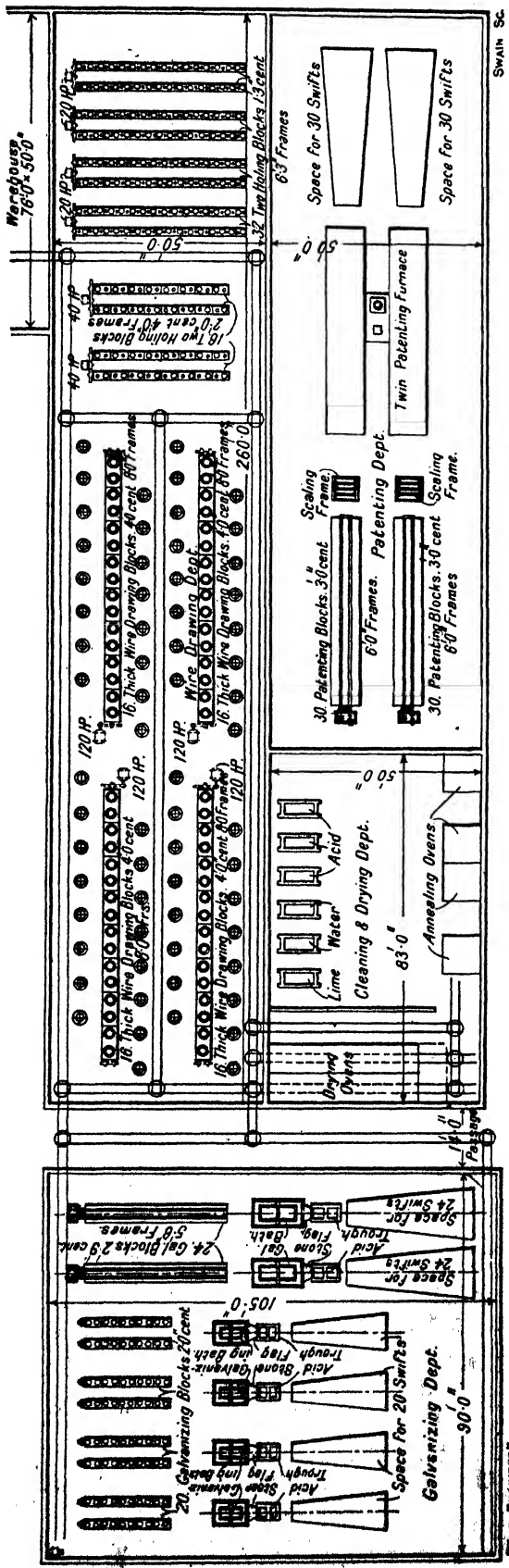

FIG. 9.—GENERAL ARRANGEMENT OF TYPICAL WIRE-DRAWING PLANT.

WIRE DRAWING

temperature is carried as high as 950 deg. Cent. Tempering is merely a modification of the patenting process. The furnaces for these processes will be described later.

There are, of course, other peculiarities of wire rods which affect their suitability for drawing, such as segregation in the ingot and cold shuts in rolling, but they are outside the control of the wire drawer, and need not be discussed here.

The pickling or cleaning process already referred to is one of the most important stages in wire drawing, and is not only concerned with the removal of the mill scale from the rod, but also with the preparation of the wire rods for the drawing blocks.

The primary object of pickling is, of course, to remove the mill scale, so as to prevent it damaging the dies, and dilute hydrochloric acid is used for the purpose. The coils of wire rod are left in the acid bath until all the scale has been dissolved, are then washed in clean water, and "banged" on the floor to remove any adhering dirt. Machines have been evolved for doing the banging, notably one by Mr. Titley, of Birmingham, by jolting the coils of wire on excentrically operated pegs; but although the work of manual banging is certainly arduous labour, it appears to be preferred in most factories to mechanical means. It is not, however, always necessary to bang the rods, and some come out of the bath so clean that they can be passed on to the next operation directly.

The rods are then thoroughly washed and allowed to stand for some time until they are "browned," or coated with a thin film of ferric-hydrate. This coating of the rod is very important, and has a great influence on its subsequent behaviour in being drawn down to fine wire. During the browning process it is important that the metal should be kept moist with water, and have free access of air to get the desired coating. If the coils are allowed to dry they will get rusty, and cause trouble in the drawing. The extent to which the browning is allowed to progress is dependent on the fineness of the wire to be drawn—the finer the wire the thicker the coating.

The coils are then dipped into boiling lime water, to neutralise any free acid, and finally baked at a temperature of about 100 deg. Cent. The coating of lime serves the two purposes of (a) protecting the film of ferric-hydrate from damage, and (b) of preventing the surface from corroding. In some wire mills the rods pass through an intermediate process, known as "lacquering," between the browning and liming. It consists of dipping the coils in a bath of dilute copper sulphate and flour, with several other ingredients, according to the fancy of the man in charge. The result is a faint deposit of copper, which helps to protect the browning.

The baking is very essential, as, were it omitted, the rod would probably be very brittle or possess "brittle of pickling," as it is termed in the trade. This characteristic was recognised as long ago as 1880, when Hughes found that unhardened steel pickled

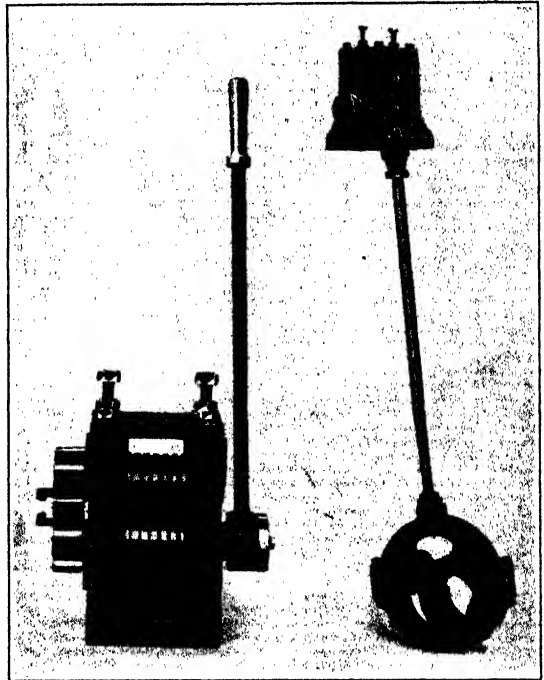

FIGS. 10 AND 11.—POINTING ROLLS—
G. CROSSLEY.

BRITISH WIRE-DRAWING AND WIRE-WORKING MACHINERY

in hot dilute sulphuric acid became very brittle. He found that the steel absorbed some of the hydrogen liberated from the acid, and remained brittle until the hydrogen had been dissipated again. This dissipation can be effected either by long exposure to the air or by heating for a shorter period of time.

A piece of high-carbon steel wire, tough enough to bend on itself without fracturing, will, immediately after pickling, break off short on bending. If, however, it is left in the air for some time, or heated for a short time to from 250 deg. to 300 deg. Cent. immediately after pickling, it will bend double as readily as the unpickled material. Although Hughes attributed the embrittling effect to hydrogen, some investigators put it down to the acid itself, but, whichever may be the cause, the effect is very marked, and must be guarded against.

The rod is now ready to go to the wire-drawing department, but before describing the various types of drawing block, it may be as well to make a few comments on the general lay-out of a wire-drawing factory.

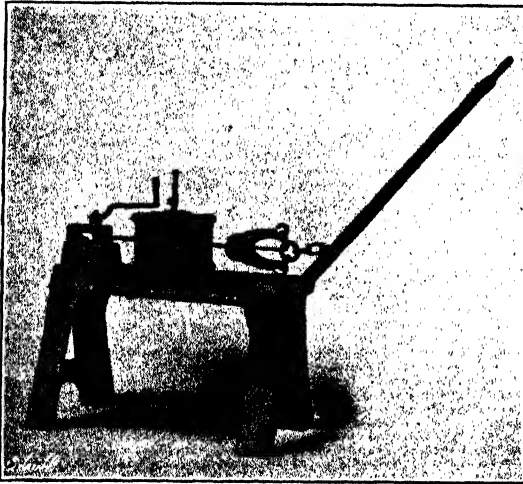

FIG. 12.—POINTING FURNACE—G. CROSSLEY.

LAY-OUT OF FACTORIES

That inertia of thought, or conservatism, among manufacturers which is so often the despair of economists is perhaps more in evidence in the wire-drawing trade than in any other branch of engineering.

When wire drawing began to take a prominent place in the industries of Birmingham in the eighteenth century, the wire drawer did all the work pertaining to his business; that is to say, cleaned, drew and annealed the wire in

turn, besides maintaining his dies in working condition. The result was that the shop was cluttered up with the plant necessary for all these operations, crowded close together, and there are still shops in Birmingham working on almost identical principles. In such circumstances the gear becomes grimed with dirt, and it is really remarkable that a presentable piece of wire can be produced.

There are, of course, some excellently equipped wire-drawing works in the Birmingham district, but it is noticeable that as one goes North the working conditions improve. In Birmingham the benches are almost invariably set against the walls of the shop, and as a consequence there is a tendency for refuse to collect beneath them to the detriment of the gearing working the machines. In the North, however, the lines of drawing blocks are generally arranged out in the middle of the room, with the men working alternately on either side. This scheme has the advantage that both sides of the machines are accessible for cleaning or overhaul, while the staggered arrangement of the operatives reduces the overall length of the plant for a given output.

In modern works the pickling, annealing and pointing processes are carried out in departments quite distinct from the drawing shops, and there is a tendency for the maintenance of the dies also to be taken out of the wire drawer's hands. That is to say, in the most modern factories the dies are prepared in a special tool-room, and are issued to the wire drawer according to requirements. When they are worn, the dies are sent back for adjustment. The rods, also, are pointed ready for threading through

WIRE DRAWING

the dies before they are sent to the drawing mill, and everything possible is done to sectionalise the work of the factory.

The power required for driving a wire mill is considerable—as much as 50 horse-power may be absorbed at a single die—and various formulæ have been put forward for its determination. One, suggested by an anonymous writer in the *Mechanical World* of 1916, Vol. 60, page 165, is as follows :—

$$\text{H.P.} = T (A - a) S \frac{F}{33,000}$$

T = Tensile strength of material in lb. per square inch before drawing.

S = Speed of drawing in feet per minute.

A = Cross sectional area of wire in square inches before drawing.

a = Cross sectional area of wire in square inches after drawing.

F = A factor selected from a curve in which percentage reductions of area are plotted as abscissæ and factors as ordinates.

There is, however, no unanimity on the subject, and it must be borne in mind that the friction of the material in the die is so important and so variable that it is very difficult to predict the power required, except on the basis of long experience.

The power is transmitted to the machines in the more old-fashioned mills by means of underground shafting, but there is a decided tendency to adopt electric driving. For the heavier classes of wire, it is best to provide a motor for each drawing block, while for lighter wires the blocks are generally grouped and driven by motors through shafts in the bases of the machines. The electric drive has the advantages that the speed may be varied as required by different gauges of wire, that the stoppage of one machine need not affect any others, while the machine can be started and stopped more conveniently when it is being prepared for work. The electric motor also has the merit that it gives a very smooth drive, which is almost as important in a wire-drawing factory as it is in a spinning mill. The drawing, Fig. 9, shows the general arrangement of a mill equipped with sixty-four main drawing blocks and their subsidiary appliances, and gives a good idea of a typical Yorkshire factory, as recommended by George Crossley, Limited, of Cleckheaton. It will be seen that the benches of blocks are arranged well out in the room, and that each bench has its own electric motor, while the several departments are well separated.

There are, nevertheless, many notable wire-drawing factories in the country which

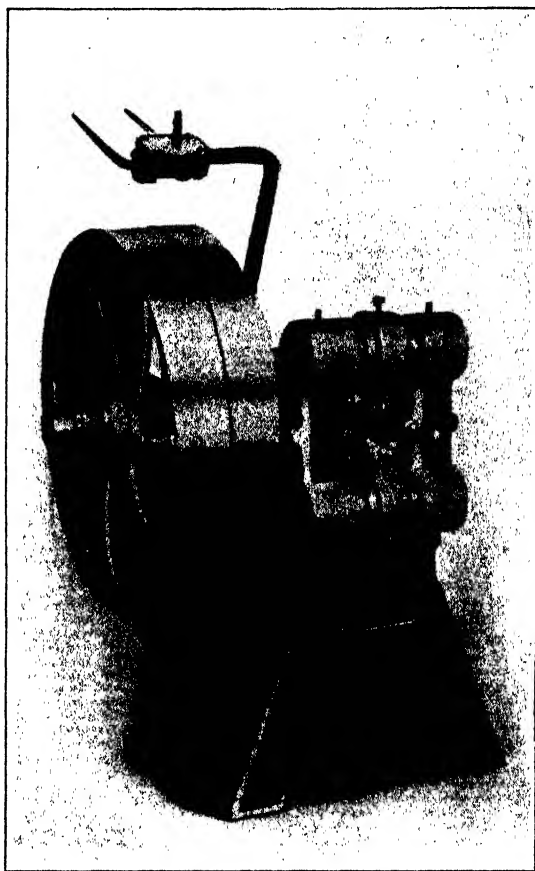
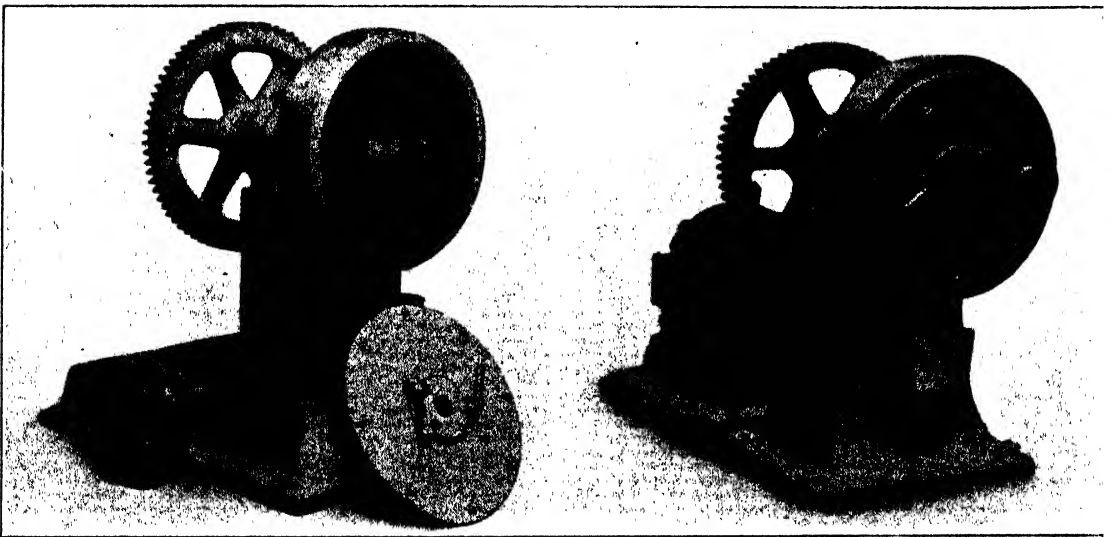

FIG. 13.—POINTING MACHINE—G. CROSSLEY.

BRITISH WIRE-DRAWING AND WIRE-WORKING MACHINERY

are still driven directly by steam engines, and for some classes of work that system is very hard to beat. The wire-drawing block runs at a comparatively low speed, and a large amount of power is required by the machines covering only a moderate floor space, so that with an engine and shafting the power can be delivered to the drawing block very economically and by means of plant not liable to get out of order. The question of reliability is naturally one of importance in any factory, but in a wire-drawing mill it is of paramount importance if there is to be peace among the men, as they are almost invariably paid on piece rates, and if the engine stops or anything goes wrong with the driving gear the men get very irritable.

At the Cleckheaton works of E. and A. Smith and Co.—one of the large steel wire firms of Yorkshire—the two mills are driven by two tandem compound condensing engines of some 800 horse-power each. These engines drive, directly, shafts running under the floor in the centre of each mill. The drawing machines are arranged at



FIGS. 14 AND 15.—ROTARY SWAGING MACHINE—SIR J. FARMER, NORTON AND CO.

right angles to the main shaft, and are driven, through bevel gearing, by transverse shafts. With such an arrangement there are very few points where power can be lost in transmission, and with a fairly continuous programme of production it appears to be quite satisfactory.

ROD POINTING MACHINES

There are several different methods of pointing wires so that they may be entered through the hole in the drawing die, and the one adopted depends principally on the output of the machines it serves.

For small works and odd jobs in the drawing shop, grooved rolls, such as those shown in Fig. 10, are very commonly installed. The grooves are made excentric to the roll, and by working the lever backwards and forwards, while the rod is pushed forward, and, if necessary, moved from groove to groove, quite a fine point can be made. Fig. 11 shows how a set of these rolls is adapted by George Crossley, Limited, to be driven off the main shaft, and fitted on a drawing bench.

A rather crude arrangement sometimes used is that shown in Fig. 12. It is merely a small gas-heated furnace, through which the end of the rod is threaded. When

WIRE DRAWING

the material has been brought up to a bright red heat, it is pulled apart by the hand lever shown, and the reduction of area at the fracture provides the required point. The system has the disadvantage that the end pulled off is scrap.

Another form of pointer is the toggle press shown in Fig. 13, which needs no description ; but the most popular type in works having any considerable output is the swaging type of machine. One of these machines, by Sir James Farmer, Norton and Co., of Manchester, is illustrated by the engravings Figs. 14 and 15. It is very simple in construction, but very effective in operation. On reference to Fig. 14, it will be seen that inside a circular casing there is a set of rollers in a cage. The path on which these rollers run is of hard steel, and is held in the cast iron casing. Through the centre of the machine there runs a hollow spindle, driven by the gearing behind. The front end of this spindle is enlarged and slotted across its diameter. This slot provides accommodation for two rectangular dies, and, outside them, two hammer blocks.

The spindle is rotated at a speed of about 300 revolutions per minute, and as a consequence the hammer blocks are thrown out by centrifugal force. As they pass the rollers, however, they are forced in again and give the dies sharp blows. The rollers rotate, but at a speed different from that of the spindle, and the dies consequently strike the rod inserted between them at different places all round, and it is quickly swaged down with a beautifully smooth surface and to a shape which corresponds to the form of the dies.

CHAPTER III

DIES

THE most critical part of a wire-drawing machine is, of course, the die, and upon its proper maintenance the success of the work entirely depends. There is, however, a total lack of precise information concerning the design of dies; and their production is a skilled handicraft guided more by experience than set rules. Thus one manufacturer will say that the reduction of the area of the wire in drawing by one-fifth is good practice, while another will claim an elongation of 50 per cent. in one pass. In

any case, so many variable conditions must be taken into consideration that it is difficult to generalise. It seems, however, that there should be some theoretical means of arriving at the best proportions of dies, as it is more or less agreed that the metal acts as a fluid in adapting itself to passage through the contracting hole, and the laws of fluid friction are well established.

Dies are generally made of steel, although cast iron is sometimes used in drawing copper, and diamond dies are employed in drawing long lengths of fine wires in continuous machines. For the heavy work of "breaking down"—the first operation on the wire rod—the die plate generally has from a dozen to eighteen holes pierced through it, and measures some 14 in. by 6 in. by $1\frac{1}{8}$ in. to $1\frac{1}{2}$ in. thick. The holes, by the way, are all the same size, and are used in turn, as they wear too large to produce the required size of wire.

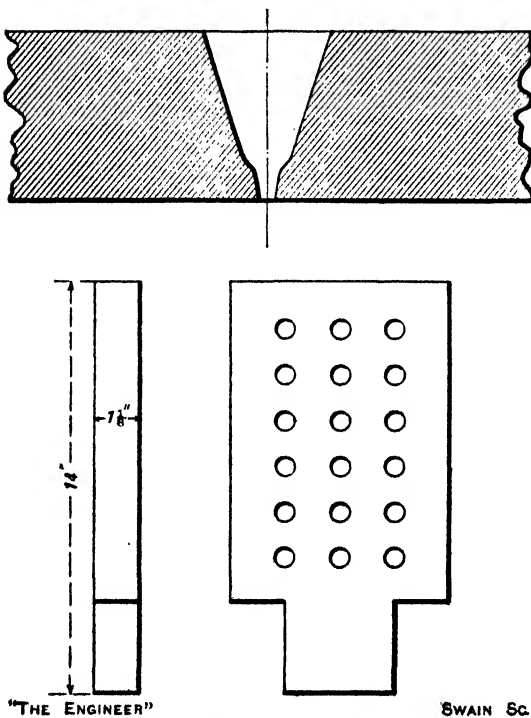

FIG. 16.—BREAKING-DOWN DIE.

The shape of the holes is shown in Fig. 16, which is reproduced from a sketch made by a practical wire drawer, and differs somewhat from some illustrations which have been published. It will be noticed that the hole has two distinct zones, a comparatively short tapered section, in which the actual drawing is done, and a bell mouth leading up to it. The important point is that the bell mouth should have a well-rounded approach to the taper, so that its walls are quite clear of the entering wire. Without this precaution, there is a liability for the metal of the die to be drawn forward by the wire, and piled up in the throat, or "the hole is pulled out," to use the words of the wire drawer. The natural result is that the opening becomes too small and the wire is scrapped. The same effect may be produced with a properly shaped

DIES

die if the wire be not thoroughly lubricated before it enters the die, but with that class of trouble we are not concerned at the moment.

The reason for the peculiar shape of the hole is probably to be found in the character of the material used in making the die and the method of hardening it. The material is almost universally plain carbon steel containing 1.5 to 2 per cent. of combined carbon. The steel is made by the crucible process and forged to size, but no attempt is made to harden the dies by tempering. Tempering would be very difficult in any case, and it would be almost impossible subsequently to maintain the size of the hole. As a consequence, the hole is roughly formed, and the metal is then hardened by hammering or "battering." This work-hardening can obviously be made to penetrate only a limited distance below the surface of the die, and this is probably why the bell mouth must be cleared well back from the bearing part of the hole, which is of a depth corresponding, approximately, to the thickness of the hardened metal.

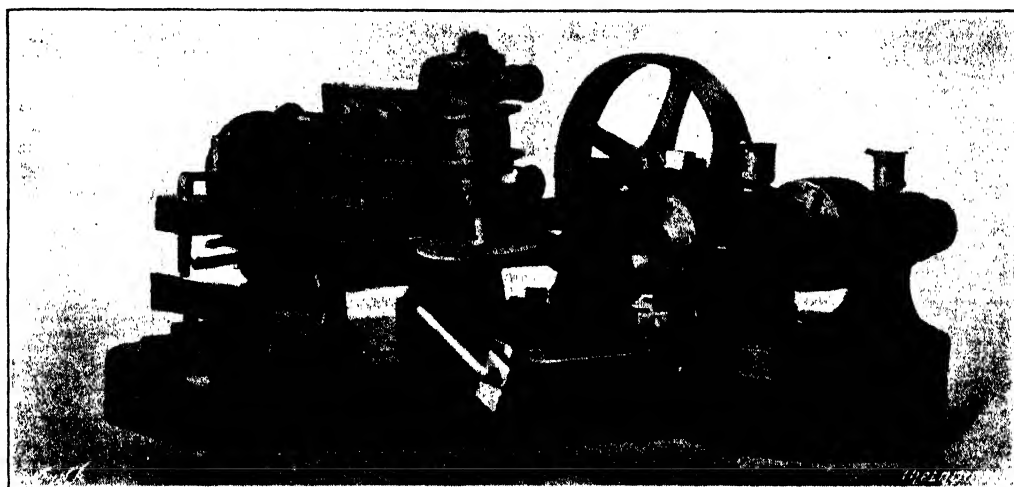

FIG. 17.—PUNCH GRINDING MACHINE—BARRON AND CROWTHER.

The process of battering the die naturally closes up the hole to some extent—it is the means actually employed for renovating a worn die—and the hole is subsequently brought to exact size by driving in a tapered drift, or punch, to give it the usual trade term, which naturally further work-hardens the metal round the hole. The production of the punches is an art in itself, and is guided almost entirely by experience.

Some wire drawers like to have hollow-ground punches; that is to say, punches in which the taper gradually diminishes as the smaller end is approached, and these punches are ground by hand. In the majority of works, however, straight-tapered punches are used, and although many of them are still ground by hand, the operation is obviously one which can readily be performed on an automatic machine.

Such a machine, by Barron and Crowther, of Preston, is illustrated by Fig. 17. The punch is held in a self-centring chuck mounted on a spindle, which can be set at the proper angle, with regard to the base, to give the desired taper. A small abrasive wheel is mounted on a vertical spindle carried by a sliding head, and is traversed backwards and forwards along the punch by a gear-driven double-threaded screw. The grinding wheel is fed up to its work by means of a micrometer screw.

BRITISH WIRE-DRAWING AND WIRE-WORKING MACHINERY

In some few works the finishing of the hole is effected by a drilling or reaming process, which is said to be quicker, but it is plain to see that the final result cannot be so satisfactory. Neither is the surface of the hole so smooth, nor is it so hard, as is the case when it is drifted out.

When steel or hard brass wire is being drawn the wear of the die is considerable, and if the nominal size is to be kept within the limits now generally specified by purchasers, the dies have to be frequently battered and re-set with the punch. Up

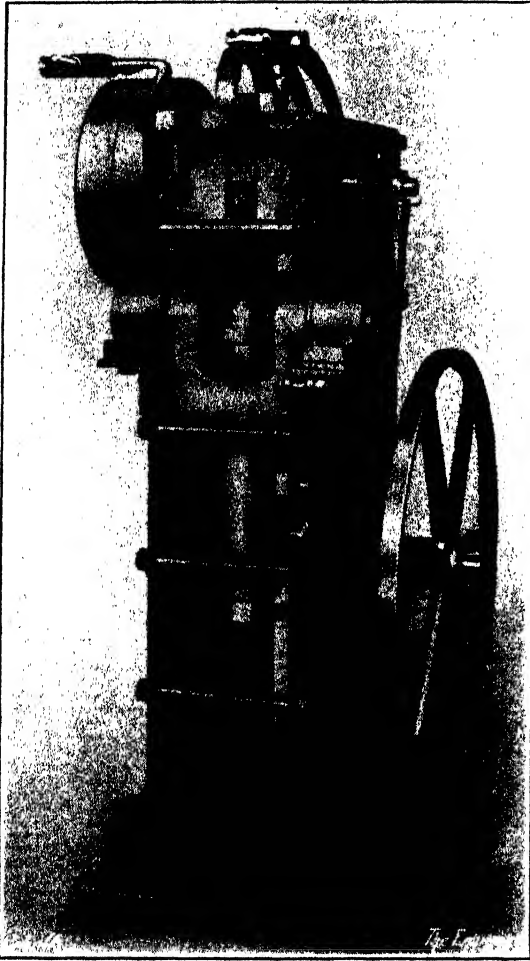

FIG. 18.—DIE-BATTERING MACHINE—G. CROSSLEY.

to recent times these operations have been carried out by the wire drawer himself, at his drawing block, and the cracked tables of many machines give evidence of the fact that they are used as anvils. The maintenance of the dies in this way naturally occupies a considerable proportion of the wire drawer's time, during which the machine is generally left standing, with a corresponding reduction in output, and there is a very marked tendency towards the adoption of tool-room principles in this direction. That is to say, the dies are prepared in a special department, and issued as required to the drawing benches. When they are worn they are then sent back for readjustment, just like the tools in an engineering works.

One of the most important items of equipment in the die shop is the battering machine, one type of which is illustrated in Figs. 18 and 19. It is the invention of Haley and Pinder, and is manufactured by George Crossley and Co., of Cleckheaton. It is, by the way, intended for the battering of the single-hole dies used after the first breaking-down operation on the wire.

Referring to Fig. 19, it will be observed that the die A is mounted in a chuck at the head of a rotatable anvil B. The anvil is carried in a

Y-shaped casting C, which can rock in bearings D in the main frame, and the position of the top of the die, with regard to the centre of the bearings, is such that as the Y casting is rocked the die will move through a circular path corresponding to the desired curvature of its surface. The rocking motion is imparted by the rack and pinion E, while the rotation of the anvil is effected by the ratchet F, working in conjunction with the skew gearing just below the die chuck.

Above the die there is a hammer G, driven through a bow spring and lever J from the excentric H on the main shaft. This excentric also operates the ratchet F. The rear fulcrum of the lever J can be raised or lowered by the hand lever K, and in this way the force of the hammer blows may be moderated to suit the requirements. It

DIES

will readily be appreciated that by the combination of the several movements the whole of the top face of the die is battered evenly and to the proper curvature, far more quickly and thoroughly than is possible by hand. At the same time, the operation has the effect of drawing the metal of the die from the outer edges up towards the eye, so as to close the hole after it has been worn in service, and does not leave a hollow at the centre, as was the case with some early battering machines not fitted with the rocking motion.

With one or two machines of this type set up in a shop specially provided for the purpose, the dies can be kept in much better order than is possible when they are battered promiscuously in the wire-drawing shop, while the arrangement reduces the

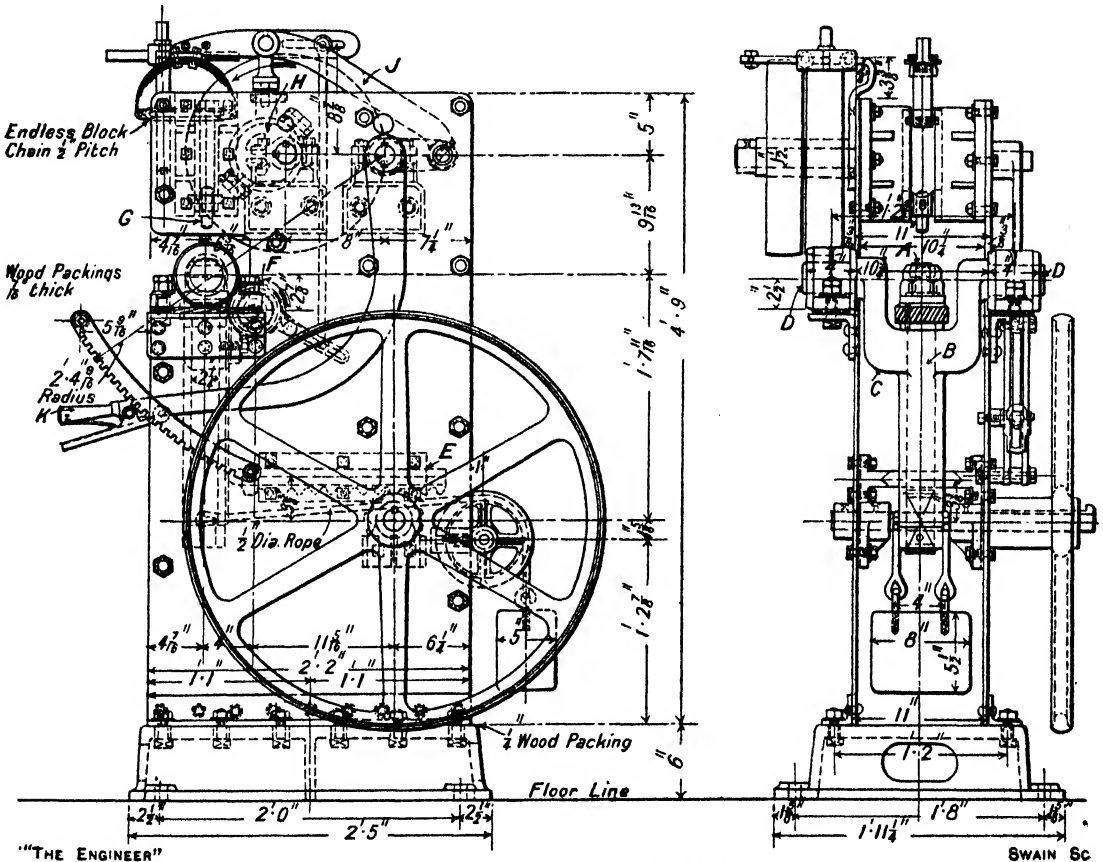

FIG. 19.—HALEY AND PINDER DIE-BATTERING MACHINE—G. CROSSLEY.

number of skilled hands necessary. Incidentally, it forms an insurance against the breakage of the drawing machine tops, which too often are cracked through the punishment they get when the wire drawer batters his own dies on the machine.

Another important consideration is the saving in lost time which can be effected in the wire-drawing department by eliminating the maintenance of the dies from its routine. It is generally agreed that the actual productive time of a wire-drawing block operated under the old conditions is little, if any, more than one-half of the elapsed time. The remainder is taken up in preparing the machine, taking off the finished wire, and, most important, the dressing of the dies. If the dies are maintained by a separate department, and issued to the wire drawer ready for use as required, a much greater quantity of wire can be drawn in the same time.

BRITISH WIRE-DRAWING AND WIRE-WORKING MACHINERY

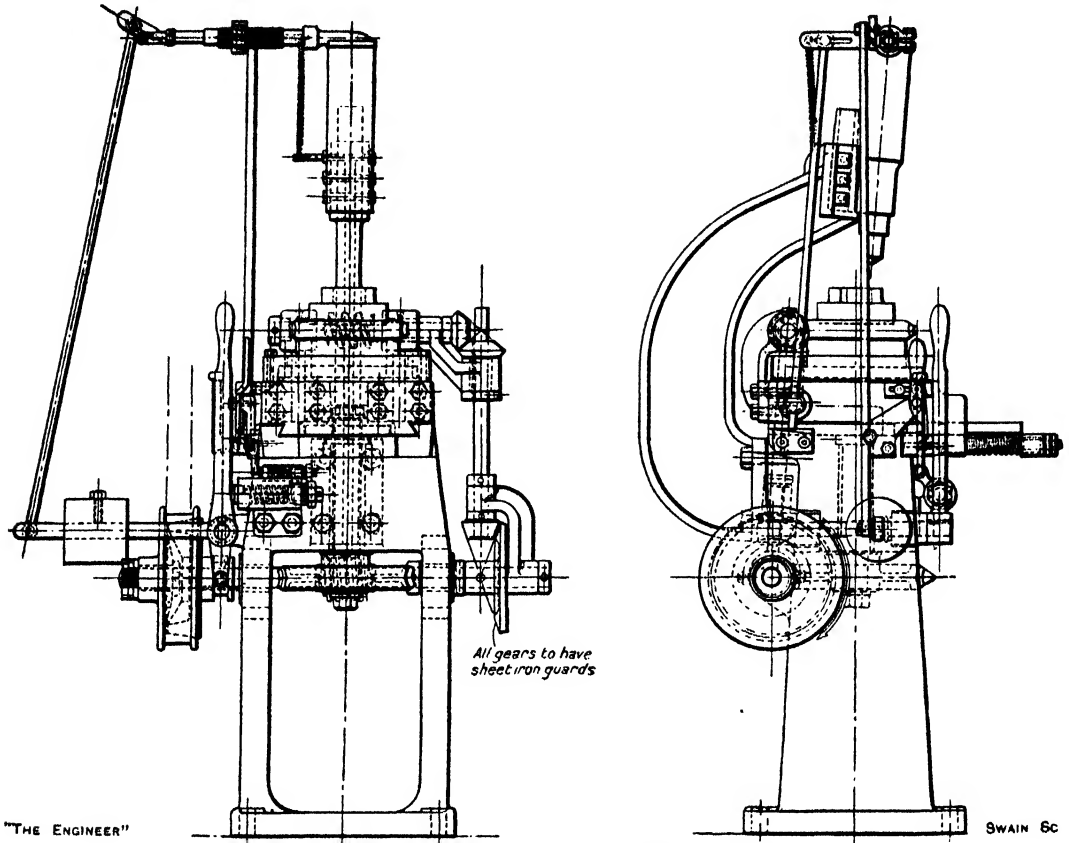

FIG. 20.—PNEUMATIC DIE-BATTERING MACHINE—ALLDAYS.

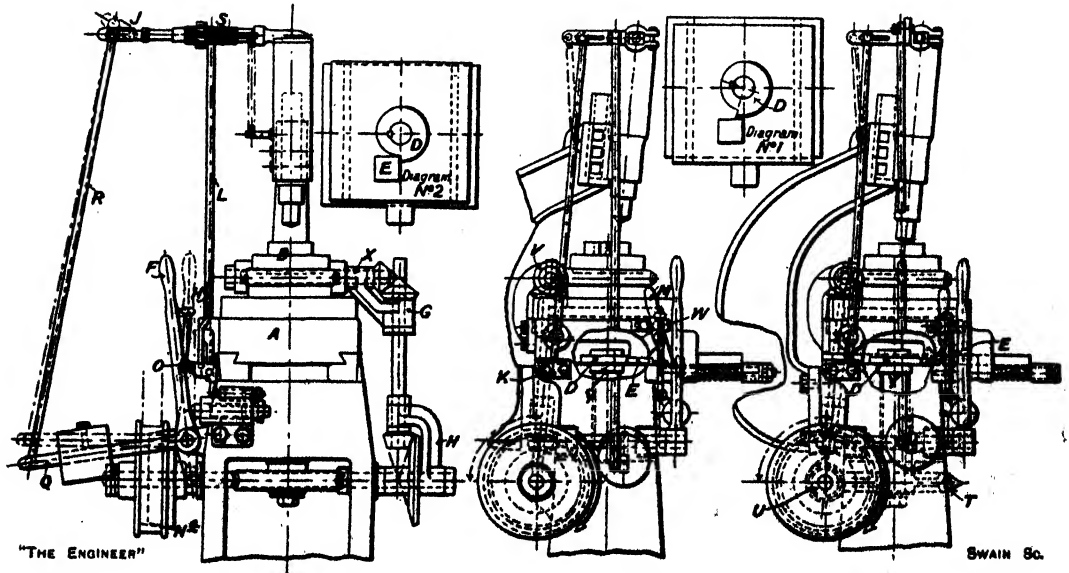

FIG. 21.—DIAGRAMS 1 AND 2—MECHANISM OF DIE-BATTERING MACHINE.

DIES

An entirely new form of die-battering machine by Alldays and Onions, Limited, of Small Heath, Birmingham, is illustrated by the drawings Figs. 20 and 21. In it the blows are delivered by a pneumatic hammer, while the die is manipulated mechanically, and the makers claim that the arrangement has the advantages that the dies are battered evenly all over, the metal is drawn towards the centre of the die; the bearing therefore retains its length, and the dies are less distorted from their original shape. Three to four dies can be battered per minute, and under this process the life of the dies is said to be greatly increased. The machine is completely guarded, the working parts being enclosed, but the diagrams 1 and 2 of Fig. 21 are given to show the mechanism.

The blow is delivered at a fixed angle to the axis of the die to be operated upon, and at the same time the work holder rotates and traverses across the face of the hammer, which is arranged to give variable power blows. The hammer, it will be seen, is carried by a bracket supported from the pedestal of the machine, while the work is placed in a receiver, which is capable of revolving, and is carried on a slide operated by a cam. The slide moves in such a manner that blows are received upon the work on a path forming a slow spiral, until the last revolution, when the blows fall on a circle around the centre of the work. The blows of the hammer are automatically varied in force by the adjustment of the hammer valve by means of a rod, which is moved over an inclined plane as the slide traverses through its stroke.

After placing the die in the receiver of the revolving table B, the machine, which is belt-driven through a single pulley and friction clutch, is set in motion by moving the lever F towards the centre of the machine. This action engages the clutch N with the pulley, and sets the rotary parts of the machine in motion. Simultaneously, through the lever Q and link R the main compressed air valve J is opened. The hammer immediately comes into contact with the work and starts to strike blows. When the machine is in motion the lever F is held in position by pressing down the control O, which, in turn, is held by the automatically operated trip plate M.

The rotary parts of the machine are driven through the pulley shaft, which, on the centre line of the machine, carries the worm U. This worm engages the worm wheel T, carried on the vertical shaft Y, upon which is mounted the cam D. This cam engages with the cam plate E to obtain the traverse motion of the slide A. The table B is revolved through bevel gears carried in the bracket H, the crown wheel being fixed at the opposite end to the pulley on the driving shaft, while the pinion is keyed to a vertical spline shaft, capable of sliding through the bevel sleeve gear revolving in the bracket G. The brackets H and G are capable of swivelling on the pulley shaft and the horizontal shaft X, in order to maintain alignment as the cross slide travels through its stroke. The worm shaft X is driven by the bevel pinion in the bracket G, and is carried in bearings secured to the slide A. Between the bearings is mounted the worm V, which engages with the worm wheel of the revolving table B.

When the slide A is moving on the forward stroke, the rod L is held by a spring against the adjustable inclined plane K, and, as it goes forward, revolves the valve S of the hammer, and thus regulates the force of the blows on the die.

The diagram No. 1 shows the cam D approaching the end of its cycle, and No. 2 shows the position of the cam D and plate E when the machine has completed its cycle and is stationary for reloading. On the return of the slide, which is spring-loaded against the cam D, the striker plate W strikes the trip plate M and releases the control O. This, in turn, liberates the main lever F, to fall into the "off" or

BRITISH WIRE-DRAWING AND WIRE-WORKING MACHINERY

“ stop ” position. At the same time the main air valve J is closed, and the tup of the hammer rises away from the work.

DIAMOND DIES

Diamond dies, to which reference has already been made, are made in this country by only one firm, Thomas Bolton and Sons, Limited, of Richmond Road, Parkstone, Dorset, although a considerable number of Continental-made dies are used.

Diamond wire dies or draw-plates—see Fig. 22—consist of commercial diamonds drilled and mounted in brass or other metal cases, and are used in wire mills for drawing wire for electrical or other purposes. The great superiority over steel and other forms of draw-plates is accounted for by the hardness of the diamond, and its consequent freedom from wear, which enables large quantities of wire of uniform gauge to be produced without changing the die.

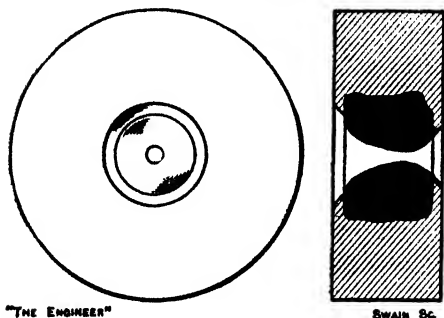

“THE ENGINEER”

SWAIN & Co.

FIG. 22.—DIAMOND DIE—T. BOLTON.

In the manufacture of these dies the rough diamonds are first trimmed with diamond points, and are then drilled by means of small steel drills, fed with diamond powder and made to oscillate mechanically for many hours. As only diamond can cut diamond, it is essential to use diamond powder to accomplish the work of boring. When pierced, the holes are shaped to suit the class of metal that is to be drawn. They are then polished to the required gauge, and adjusted to within one-ten-thousandth part of an inch, being finally mounted in brass cases a little larger than 1 in. in diameter, in readiness for use.

The sizes of the holes range between about $\frac{1}{10}$ in. and $\frac{1}{10000}$ in., the smallest dies being used for drawing tungsten filaments for electrical lamps, and it is a cause of surprise to most people that so microscopical a hole as 0.0004 in. can be accurately drilled through a diamond. The whole of the machinery used is electrically driven at high speed, and several machines are looked after by one employee.

It is interesting to note that the following classes of wires are drawn through diamonds: Telephone, telegraph, submarine cable, wireless aerial and coil, tungsten filament, nickel chrome resistance wire, weaving wires for wire cloths, brush wire, scratch brush wire, bookbinding wire, pin and safety pin wires, platinum, gold and silver for the jewellery industry, gold and silver thread for braid, etc., surgical wire, music wires, carding wires for the textile trade, electric fuse wires, bronze spring wires and others.

CHAPTER IV

WIRE-DRAWING BLOCKS

THE machines used for drawing heavy gauge wire are generally referred to as wire-drawing blocks, but the significance of the name is rather puzzling, unless it has some relation to the term pulley block, which is quite possible, seeing that the purpose of the block is to pull the wire through the die.

The general outline of all wire-drawing blocks is much the same, although minor

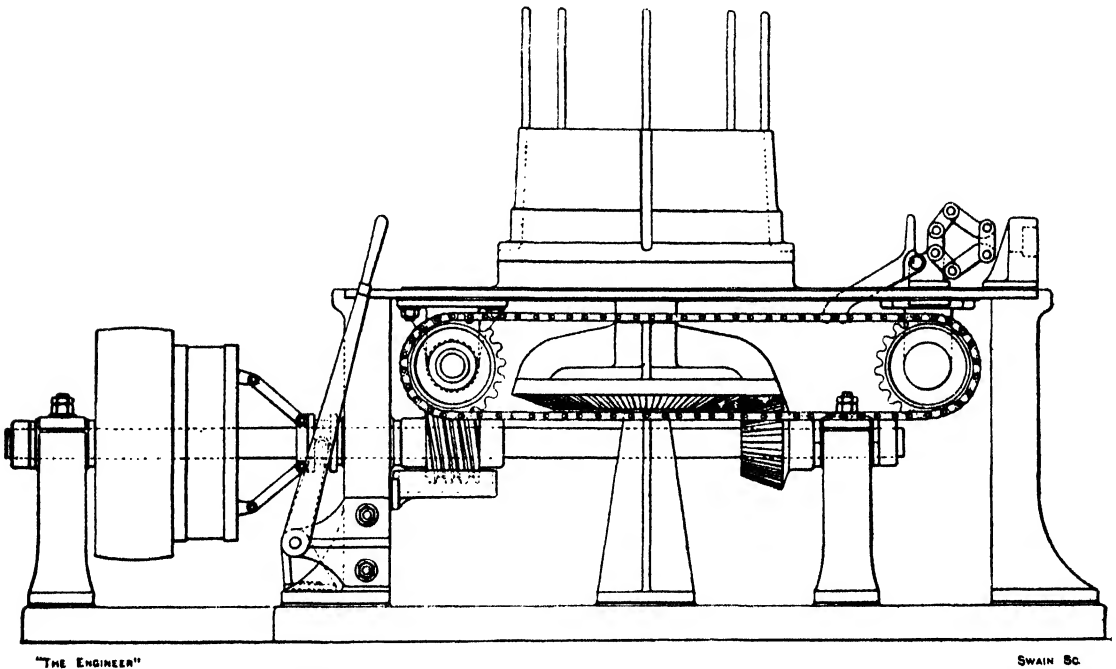

FIG. 23.—SINGLE WIRE-DRAWING BLOCK—DAVID BRIDGE.

variations are introduced by different makers, largely, it would seem, to give an individual character to their machines, although there are, of course, cases in which the consideration of cost is the principal item in the determination of the design and workmanship put into the block. There are only three essential working parts in the machine—the die and its holder, the drum-like block, round which the wire is coiled, and a mechanism for pulling the first end of the wire through the die until sufficient length has been drawn through for its attachment to the block. These three units are assembled in a framing in various fashions, according to the work to be done.

For the heavy work of “breaking down” the wire rod each block generally has its own individual frame, and, as the section of the wire becomes lighter, so more blocks are grouped in one frame. The reason for this arrangement is fairly obvious, as the breaking down pass requires much more power than the subsequent drawings, while a greater length of material has to be handled after each pass. As a consequence, one breaking down block can serve several lighter blocks.

BRITISH WIRE-DRAWING AND WIRE-WORKING MACHINERY

Figs. 23 and 24 give a good impression of two typical single wire-drawing blocks. The drawing—Fig. 23—shows the general arrangement of a machine made by David Bridge and Co., of Castleton, near Manchester, while the half-tone engraving is of one by Sir James Farmer, Norton and Co., of Salford.

The block, it will be seen, is mounted on a vertical spindle and is driven from a horizontal shaft by bevel gearing. In some designs—such as that shown in Fig. 24, for instance—the block spindle is carried right down to the base of the machine, and a footstep bearing is arranged there, while in others the footstep is placed above the horizontal shaft, on a stool or A frame. It is a matter of opinion as to which arrangement is the better, as, while the first has the advantage of providing a very rigid support for the block, it leaves the gear wheels vulnerable to any falling rubbish. With the wheels inverted—as in Fig. 23—the gear teeth are much better protected, but the

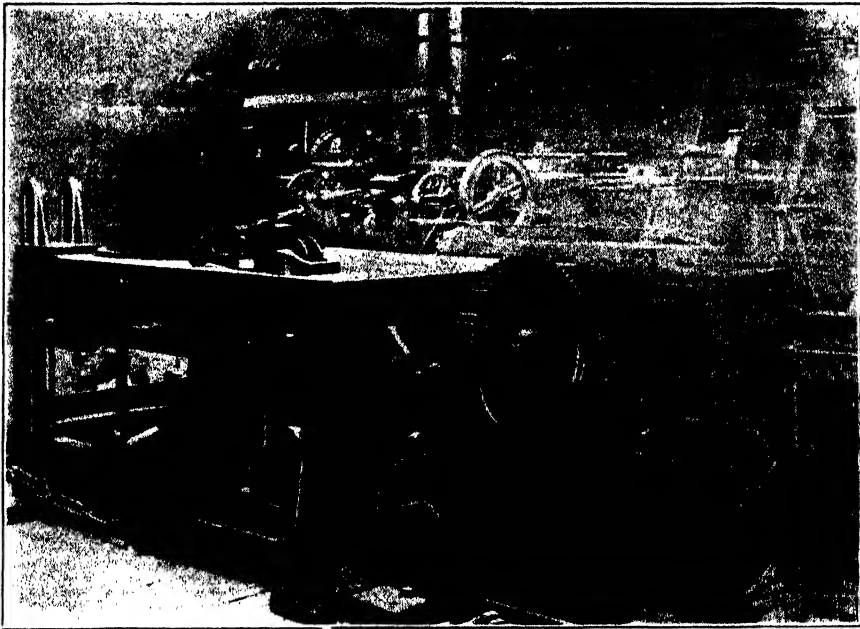

FIG. 24.—SINGLE BLOCK—SIR J. FARMER.

distance between the spindle bearings is greatly reduced, and it is a most important matter that the block should be firmly supported, as any tendency for the block to chatter or wobble may spoil the wire by snatching it through the die.

The block has, of course, to be started and stopped for each length of wire drawn, and various arrangements are adopted for setting the block in motion. In Fig. 23, it will be seen, a Heywood and Bridge's friction clutch is employed for the purpose, while a separate electric motor drive might be used to obviate the necessity of a clutch—as shown in Fig. 24, although this machine is equipped with a clutch on the block spindle operated by the pedal on the left. There are, however, several other alternative arrangements, which will be described later.

The drawing-in gear—the second of the several essential parts of the machine mentioned above—on the two machines under review is quite different, and it is in this direction that some of the most marked variations in design are found.

The old-fashioned drawing-in mechanism, and it is one still very largely used,

WIRE-DRAWING BLOCKS

specially in the Birmingham district, comprises a large cam mounted on the block spindle immediately beneath the block itself. A lever pivoted to the back of the machine and lying on the table can be brought to bear against this cam, and will then be reciprocated as the cam rotates. On the front end of the lever there is a short length of chain provided with a pair of tongs for gripping the wire

To use this gear the wire drawer pulls the chain towards the pointed end of the wire protruding through the die, and, as the cam rotates continuously, there is a time in every revolution when he can catch the grips on to the wire. The lever is then pushed forward by the cam and pulls a short length of wire through the die. The man then has to return the grips to the die to get another hold, and so on until sufficient wire has been drawn through to reach to the clamp on the block. The cam lever then lies idle on the table, clear of the cam, so that it does not go on working when not required.

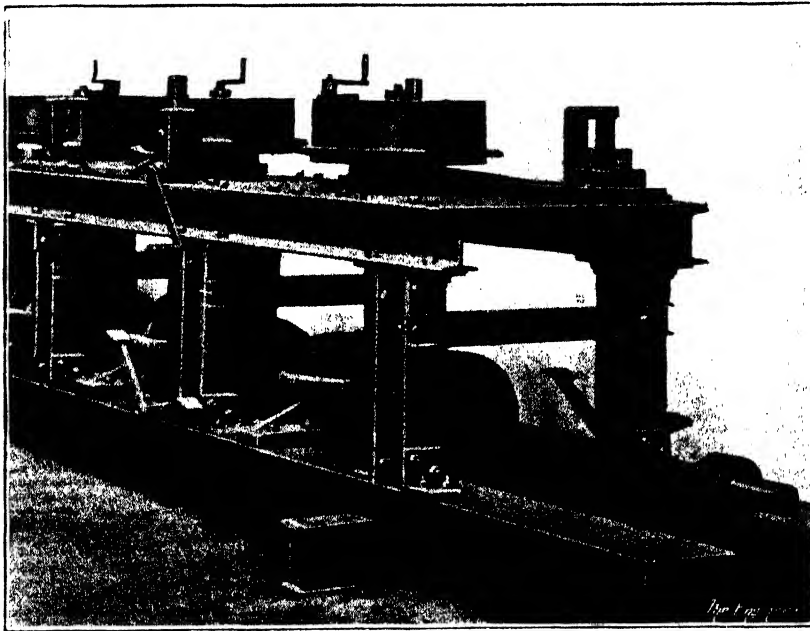

FIG. 25.—STEEL-FRAMED MACHINE—BARRON AND CROWTHER.

The mechanism is obviously very brutal in its action, as the lever swings back with considerable violence, and if the man fails to fasten the grips on the wire at the critical moment that stroke of the lever is wasted. Added to this objection there is the intermittent nature of the action, which results in a series of marks on the wire where new grips have been taken, so that an appreciable length of wire has to be scrapped on each coil.

Various arrangements have been devised for overcoming the troubles inherent to the cam and lever drawing-in gear, and Figs. 23 and 24 show two distinctive arrangements.

In the first case a flat-link chain, running over sprockets below the table, is driven off the main shaft by worm gearing. There is a slot in the table immediately above the chain, and along this slot there slides a carriage. The carriage is provided with a pair of grips for the wire and a trigger for engagement with the chain. When the wire end has been put in the grips the trigger is dropped, and a sufficient length

BRITISH WIRE-DRAWING AND WIRE-WORKING MACHINERY

of wire is drawn through, in one operation, to reach out to the clamp on the drawing block.

In the case of the machine by Sir James Farmer a round link chain is used to draw in the wire. This chain is wound on a countershaft running beneath the front of the table and driven off the main shaft by chain gearing. A clutch, operated by the cranked pedal on the right, is provided in the drive, and this clutch is interconnected with the lever which can be seen standing up in front of the chain guide pulley. The chain passes through the eye at the top of this lever and pulls the clutch out of engagement at the end of the stroke, so that the gear cannot be smashed by carelessness on the part of the operator. This machine, by the way, has a block 22 in. in diameter, with a peripheral speed of about 60 ft. per minute, and is driven by a 20 horse-power motor.

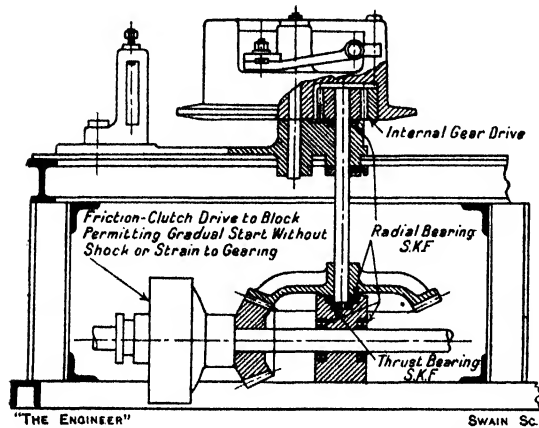

FIG. 26.—BLOCK WITH INTERNAL GEAR DRIVE—
BARRON AND CROWTHER.

The die holder, the third essential part of the wire-drawing machine, requires little comment, as it generally

takes the form of a simple bracket in which the die is held by a variety of means, such as set screws or wedges, while it is sometimes merely a slotted plate against which the die bears under the pull of the wire.

In drawing heavy wire dry powdered soap is generally used as a lubricant for

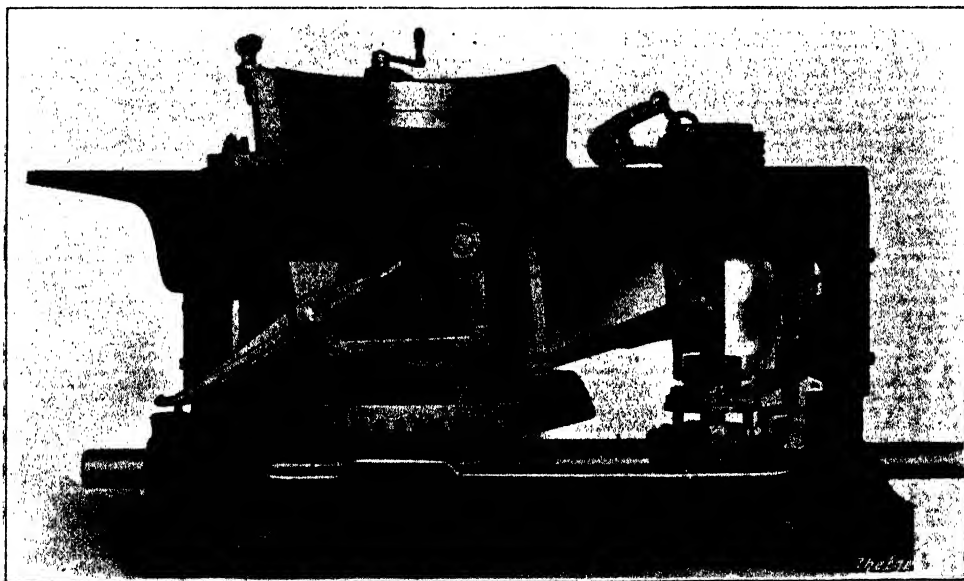

FIG. 27.—HEAVY WIRE-DRAWING BLOCK WITH FRICTION DRIVE—G. CROSSLEY.

the wire as it enters the die, and the soap is held in a box, or funnel, through which the wire runs. Sometimes a mechanical device is provided for agitating the soap and

BRITISH WIRE-DRAWING AND WIRE-WORKING MACHINERY

ensuring its contact with the wire, but more generally this requirement is attended to by the wire drawer himself.

WIRE-DRAWING BLOCKS

The face of a wire-drawing block, it will be noticed, is tapered upwards and has a distinct step near the bottom, for the purpose of easing off the wire upwards as it is coiled on to the drum. It does not appear that there are any set rules for determining the amount of this taper, as it is influenced by such a wide variety of considerations, and it is generally left to the discretion of experienced turners to settle the amount of taper put on the blocks. The reason for putting the step in the taper is the fact that only sufficient tight turns of wire should be allowed on the block to provide the friction

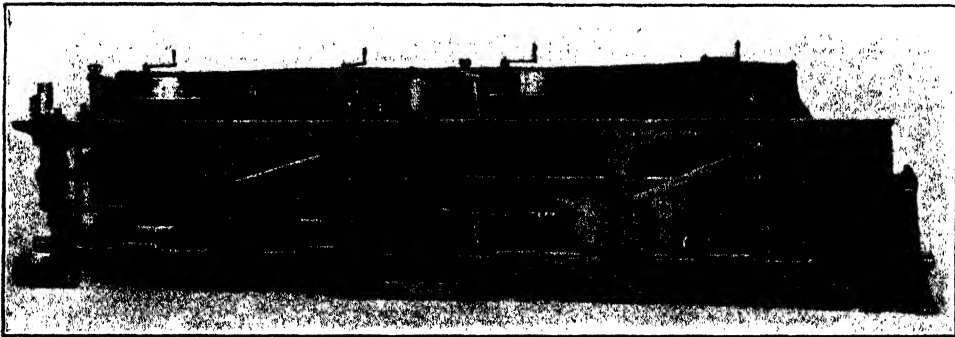
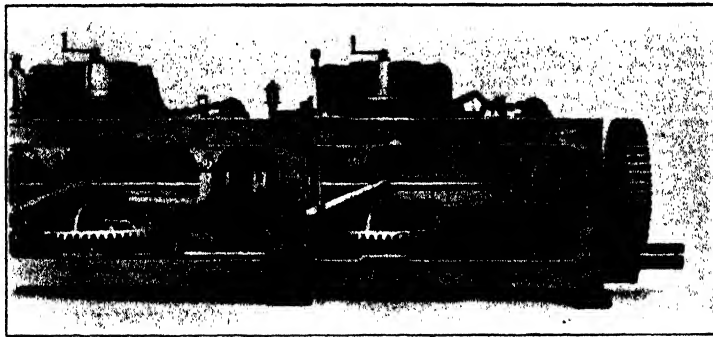

FIGS. 29 AND 30.—SINGLE-SIDED AND DOUBLE-SIDED WIRE-DRAWING FRAMES.—G. CROSSLEY.

necessary for pulling it through the die, while above that limit the coil should be quite free to rise and accumulate without tending to make the new turns ride over one another.

It should be mentioned that, at starting, the end of the wire is fastened in a clamp, at the top of the block, which has a portable handle. The first turn, however, goes down to the bottom of the block, and the fresh wire is always drawn on at the bottom. The result is that after long service a groove wears in the block where it first pulls on the wire, and this groove tends to prevent the turns of wire from fleeting off upwards. The block must then be turned up to a slightly smaller diameter to provide a fresh smooth surface.

When a long length of wire is being drawn a set of pegs is placed in sockets in the top of the block, so as virtually to form a continuation of its shape, and provide accommodation for the turns of wire as they are pushed off the top of the block, so that as much as 2 cwt. of wire is often run off in one coil, and it is one of the arts of the wire

WIRE-DRAWING BLOCKS

drawer to take off a heavy coil of wire without getting it entangled or over-exerting himself.

A distinctive type of drawing machine is made by Barron and Crowther, of Preston, and is illustrated in Figs. 25 and 26. One of its peculiarities is the use of structural steel work for the framing, in the place of the usual cast iron. The arrangement has the advantages that it is comparatively light and not liable to fracture through rough usage, while the long girders at the bottom make it possible to put the machine down and set it to work without elaborate concrete foundations.

Another feature about the machine is that it is equipped with ball bearings throughout, while the main shaft runs at the comparatively high speed of 480 revolutions per minute, with a corresponding reduction in the weight on the bearings. The machine, as a fact, runs so easily that one having half a dozen blocks in one framing can be turned over easily with one hand gripping the main shaft.

The outstanding characteristic of the machine is, however, the arrangement of

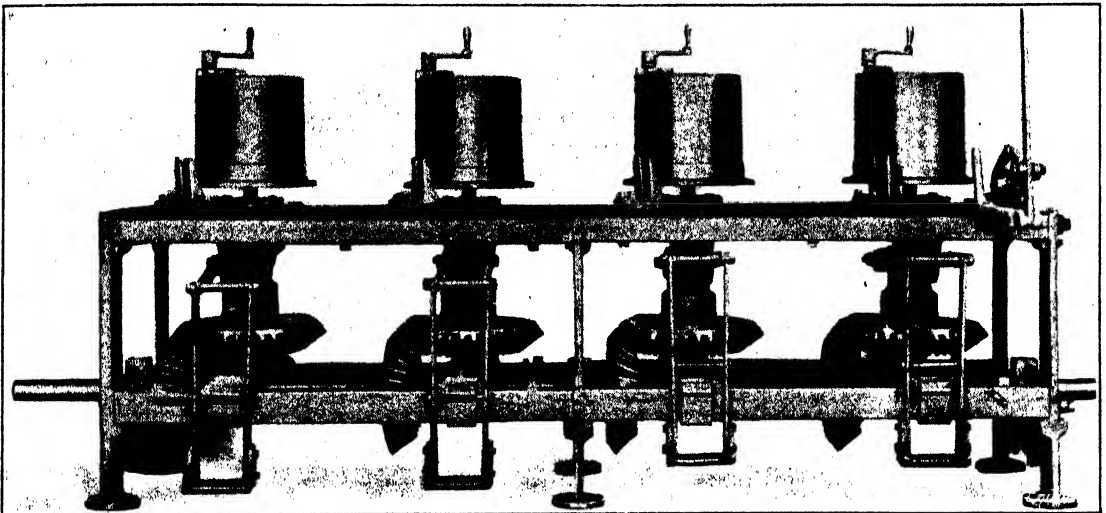

FIG. 31.—12 IN. DIAMETER WIRE-DRAWING BLOCKS—G. CROSSLEY.

the drive to the block. The block is mounted loosely on a pin fixed in a casting on the top of the table. This casting incidentally is extended to form a fixture for the die holder. Inside the lower part of the block there is fixed an internally toothed ring, which meshes with a pinion on a vertical shaft, as shown in Fig. 26. This pinion is driven through bevel gearing and a friction clutch in the usual manner. The arrangement provides a very substantial support for the block, which will run for a long time without wearing slack, while the drive is applied, as nearly as possible, to the point where the wire runs on to the drum. It is, of course, largely on account of the gear ratio provided by the internal drive that the speed of the main shaft can be kept up to the limit already mentioned, without the block running too fast for heavy work.

A very substantial type of block for heavy work, made by George Crossley, Limited, of Cleckheaton, is illustrated by Fig. 27. In this case the drive is transmitted through a friction clutch on the vertical spindle of the block, and the machine can be started up very gently even with a heavy load on. The drawing-in gear, it will be seen, takes the form of a capstan driven through a dog clutch from worm gearing. Fig. 28 is reproduced from the general arrangement of this machine. Figs. 29 and 30 also illustrate

BRITISH WIRE-DRAWING AND WIRE-WORKING MACHINERY

machines made by George Crossley, and are specially interesting through indicating the economy of space which can be effected by arranging the blocks for working on alternate sides of the bench—a matter already referred to in connection with the layout of wire-drawing factories. These two illustrations are to the same scale, and both represent machines with blocks 22 in. in diameter. It will be seen that the saving in length is in the ratio of approximately 4 to 6, while the width remains the same. Serpentine plate guards are arranged round the backs of the blocks in the case of the double-sided machine to prevent any loose end of wire flying out and hurting the man on the opposite side of the bench.

It will be noticed that in the case of the alternate-sided machines—Fig. 30—the two blocks on the left have much more powerful gearing than those on the right, with the object of breaking down the heavy stuff on the first two blocks and then passing

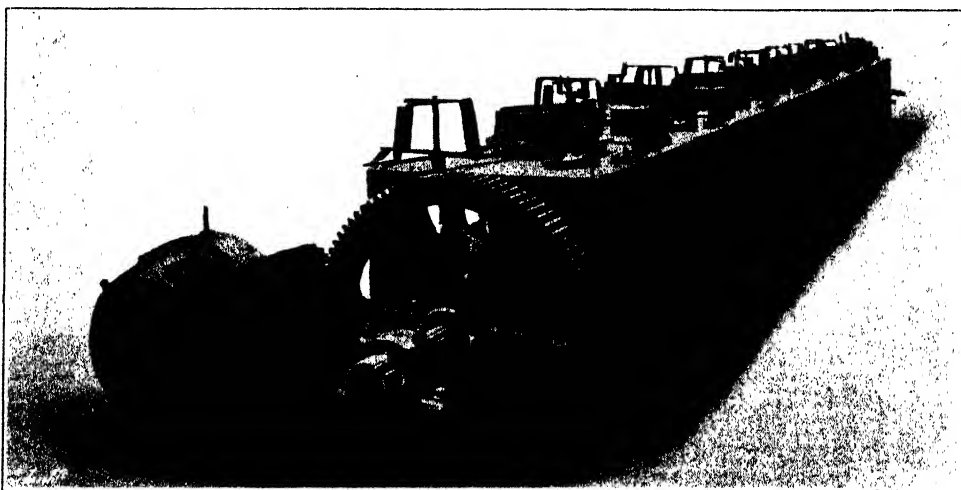

FIG. 32.—EIGHT-BLOCK WIRE-DRAWING BENCH—WM. GRICE.

it directly to the two faster blocks on the right. The drawing-in gear is of a type already described.

A very fine example of wire-drawing bench, which the makers claim to be one of the largest made in this country, is illustrated by Fig. 32.

As will be seen from the engraving, the bench is equipped with eight blocks, all of which are 20 in. in diameter. They are spaced at 5 ft. centres and are each driven by machine-cut bevel gearing and a cone clutch lined with Ferodo. The first two blocks run at 55 revolutions per minute, the next four at 65 revolutions per minute, and the last two at 80 revolutions per minute. The bevel pinions are split so that they may be easily replaced in case of breakage, without it being necessary to take out the main shaft. The machine is driven by a 60 horse-power electric motor through a compressed paper pinion and machine-cut spur wheel. The pull-in gear, it will be noticed, is of the capstan type and is driven from the main shaft by worm gear and a clutch.

An unusual feature about this machine is the arrangement of the swifts on the bench itself. This scheme was specified by the purchasers and is said to work satisfactorily, but it does not seem to give a very fair lead for the wire from the swift to the die block. The overall length of the bench is approximately 48 ft., and the makers William Grice and Sons, Limited, of Fazeley Street, Birmingham, say that it was

WIRE-DRAWING BLOCKS

lined up so accurately that it could be pulled round by hand on the main driving spur wheel with all the clutches in gear.

For the drawing of the lighter gauges of wire a more simple type of machine, such as that illustrated by Fig. 31, is generally used. This machine, by George Crossley, has 12 in. diameter blocks, which are driven through plain dog clutches on the vertical spindles. In these cases it is not worth the elaboration of providing a mechanical drawing-in gear, and the simple hand lever seen on the right is used for the purpose.

In the foregoing notes on wire-drawing blocks no attempt has been made to enlarge upon the constructional details of the machines, as they follow ordinary engineering practice, and there would be no merit in explaining, for instance, that one make of machine had yellow metal bearings, while in another they were of cast iron, as such details are merely a question of price. Also there are many other British makers of wire-drawing machinery not referred to, but the examples given are sufficient to indicate the general character of this class of plant.

CHAPTER V

CONTINUOUS WIRE-DRAWING MACHINES

THE term "continuous" is applied to a wide variety of wire-drawing machines and indicates that the wire is drawn simultaneously through more than one die by the one machine, and does not, as might at first be thought, mean that the apparatus runs on indefinitely until deliberately stopped. In the continuous machine the length

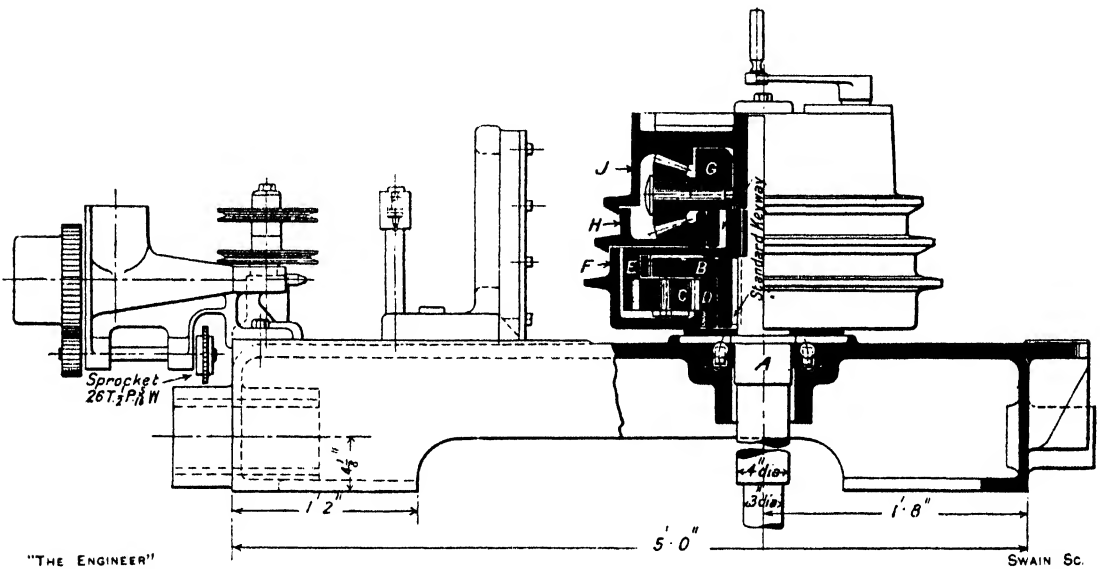

FIG. 33.—20 IN. THREE-HOLE CONTINUOUS MACHINE—BARRON AND CROWTHER.

of the run is determined by the amount of material in the coil being drawn, but there are inventors at work with the idea of evolving a really continuous process.

It seems that we have reached the present practicable limit of length in wire rods, not, of course, from the point of view of the rolling mill operator, as it has been shown that it is possible to roll a complete steel ingot down to wire rod without reheating it, which would mean a coil of rod of at least ten times the present normal weight. The difficulty in increasing the length of rods is caused by their becoming too unwieldy. But there is the possibility of welding together the lengths of rod as they are fed to the drawing machine, and then the limit of length would only be imposed by the ability of the die to stand up to size and the facilities provided for taking away the drawn wire. In any case, however, the rod would first have to be passed through one of the breaking-down machines already described, before coming to what is known as the continuous machine, which deals with the lighter sections, and this class of machine is the subject of the notes below.

In continuous drawing, which was first introduced by Woods, of Warrington, in 1872, the same trouble through extension in length is encountered as is the case with continuous rolling; but it is impracticable to take up the increase in the length of

CONTINUOUS WIRE-DRAWING MACHINES

the wire, as it is reduced in sectional area, by means of a loop, as the loop would be of inordinate length and quite unmanageable. As a consequence, means have to be adopted for passing the wire through the successive dies at correspondingly increased speeds.

In the continuous drawing machine made by Barron and Crowther, of Sedgwick Street, Preston, an ingenious adaptation of the differential gear is used to accommodate the increasing length of the wire as it passes through the dies.

The peculiar parts of the machine are illustrated by Fig. 33, which shows only the upper part, as it is otherwise of more or less standard design, except that the main spindle runs in ball bearings.

On reference to the drawing it will be seen that the spindle A is keyed to, and drives, a spider B, on which there is mounted a set of pinions C. These pinions mesh with two toothed rings D and E, of which D is fixed to the first drum F of the block, while E is keyed to a second spider G. This spider carries a second set of pinions, bevelled this time, which mesh with rings attached to the second and third drums H and J. By following out this train of gearing it will be found that each drum will give an equal pull on the turns of wire passed round it, while there is a natural tendency for any one to over-run the others if there is any reduction in the resistance to turning or slack in the wire. As a consequence it is only necessary to pass the wire round guide pulleys, as it goes from one die and drum to the next, to secure an even tension through the several passes, while there is an assurance that the wire will not slip on the block and become flattened thereby. On the left of the drawing there can be seen the two guide pulleys over which the wire is led between the second and third passes and the soap box for lubricating the wire. The box,

it will be noticed, is provided with gearing, driven off the main shaft, for rotating it and thus ensuring that the soap does not wear into a hole and leave the wire a clear passage. The bracket for holding the dies is also indicated.

The same idea has been developed and extended to cover four-hole drawing, and the arrangement then adopted is shown in Fig. 34. For four drums it is necessary to have three differential gears, and they are arranged as follows:—

The main driving wheel carries a set of pinions A which drive the spindle B and the sleeve C in a differential manner. The spindle has a set of pinions D at the top which mesh with toothed rings on the upper and second drums, while the pinions E

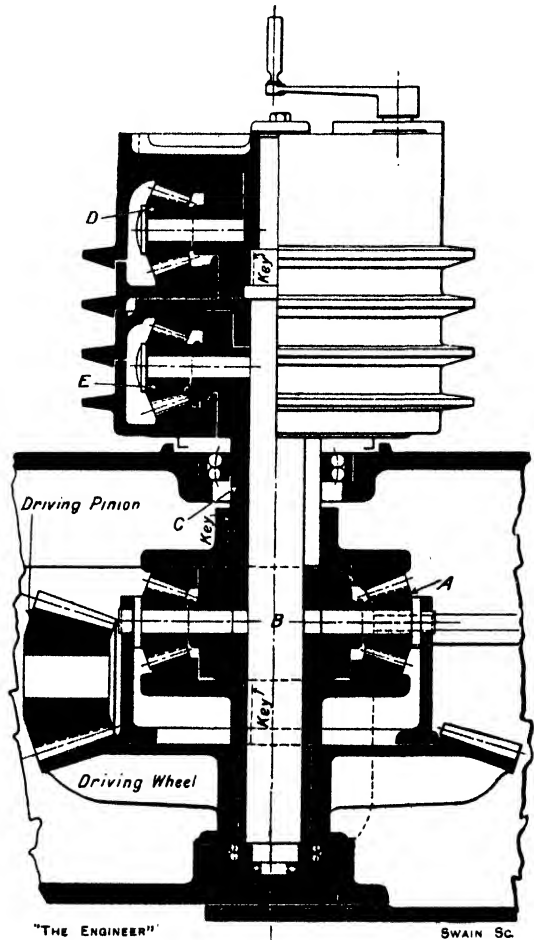

FIG. 34.—FOUR-HOLE CONTINUOUS BLOCK—
BARRON AND CROWTHER.

BRITISH WIRE-DRAWING AND WIRE-WORKING MACHINERY

of the sleeve C drive the two remaining drums, and a true differential drive is provided for all four drums. Incidentally, this drawing shows plainly the self-aligning ball bearings and ball thrust, or footstep, bearing of the Barco machines.

One of these machines with a 22 in. block, running at about 72 revolutions per

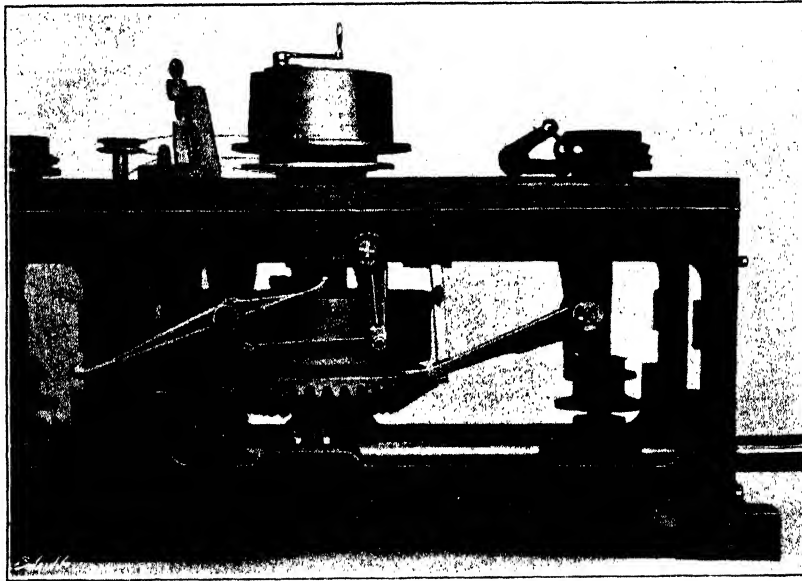

FIG. 35.—TWO-HOLE CONTINUOUS MACHINE—G. CROSSLEY.

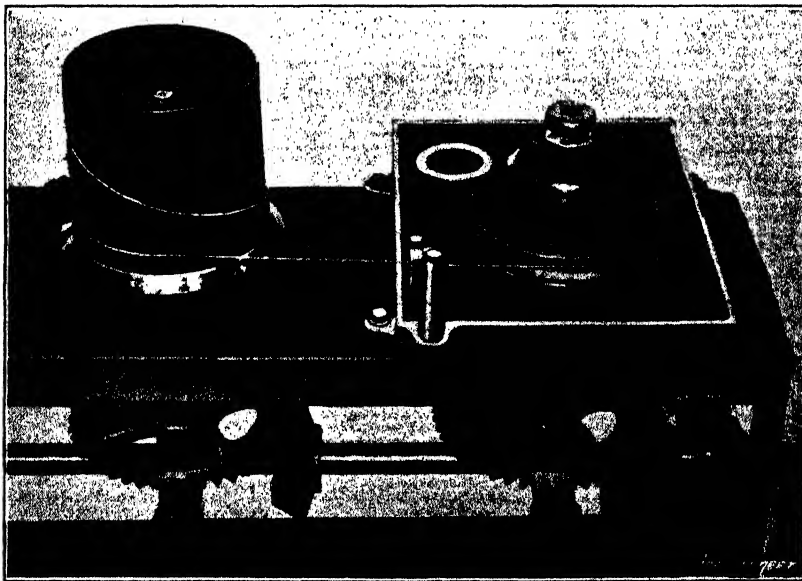

FIG. 36.—THREE-HOLE WET DRAWING MACHINE—G. CROSSLEY.

minute, will require about 15 horse-power in reducing No. 5 rods down to from No. 6 to No. 12 S.W.G. in three passes, and will turn out nearly 3,000 lb. of wire per shift of ten hours. One man can attend to two machines at a time.

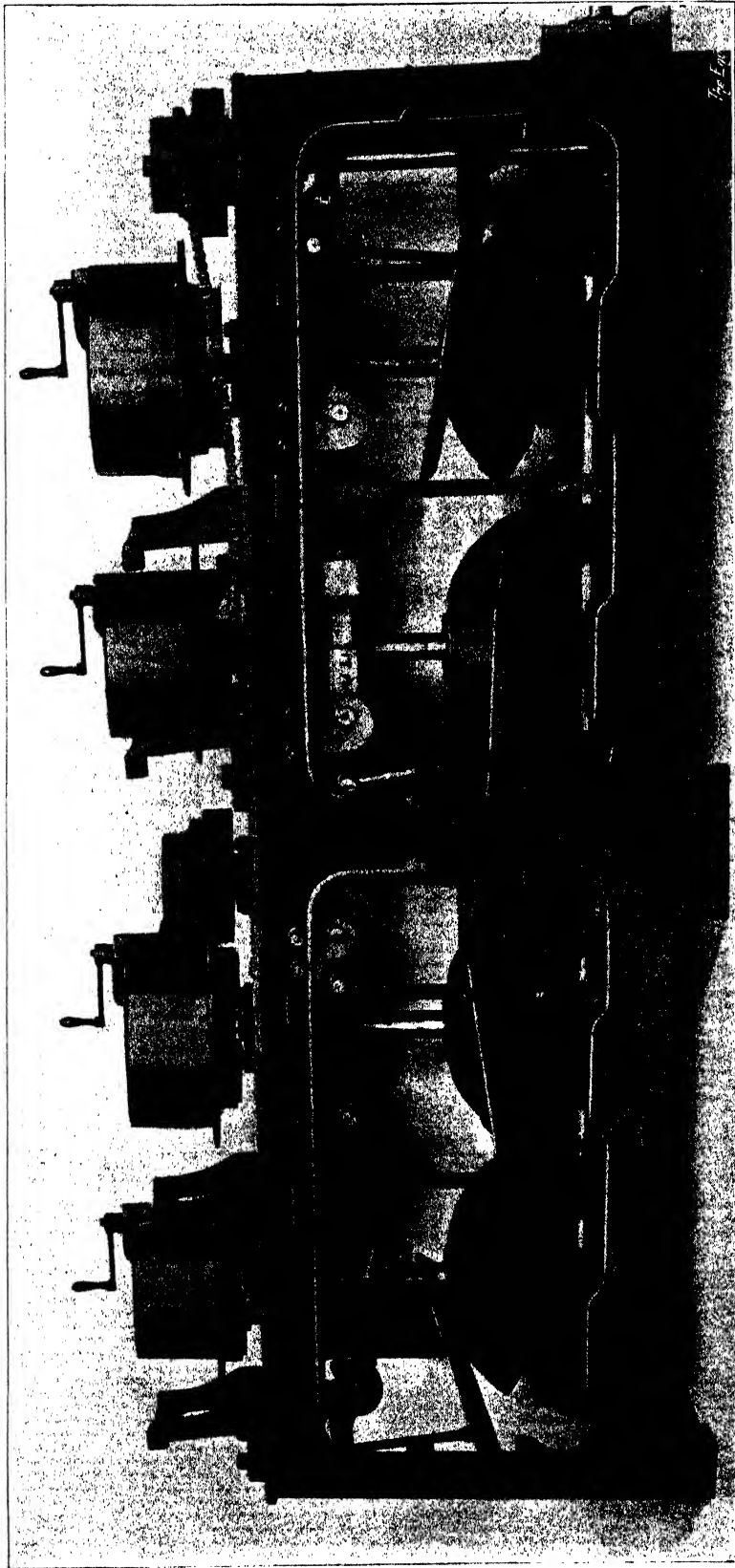

Fig. 37.—18 IN. DIAMETER TWO-HOLE CONTINUOUS WIRE-DRAWING MACHINE—G. CROSSLEY.

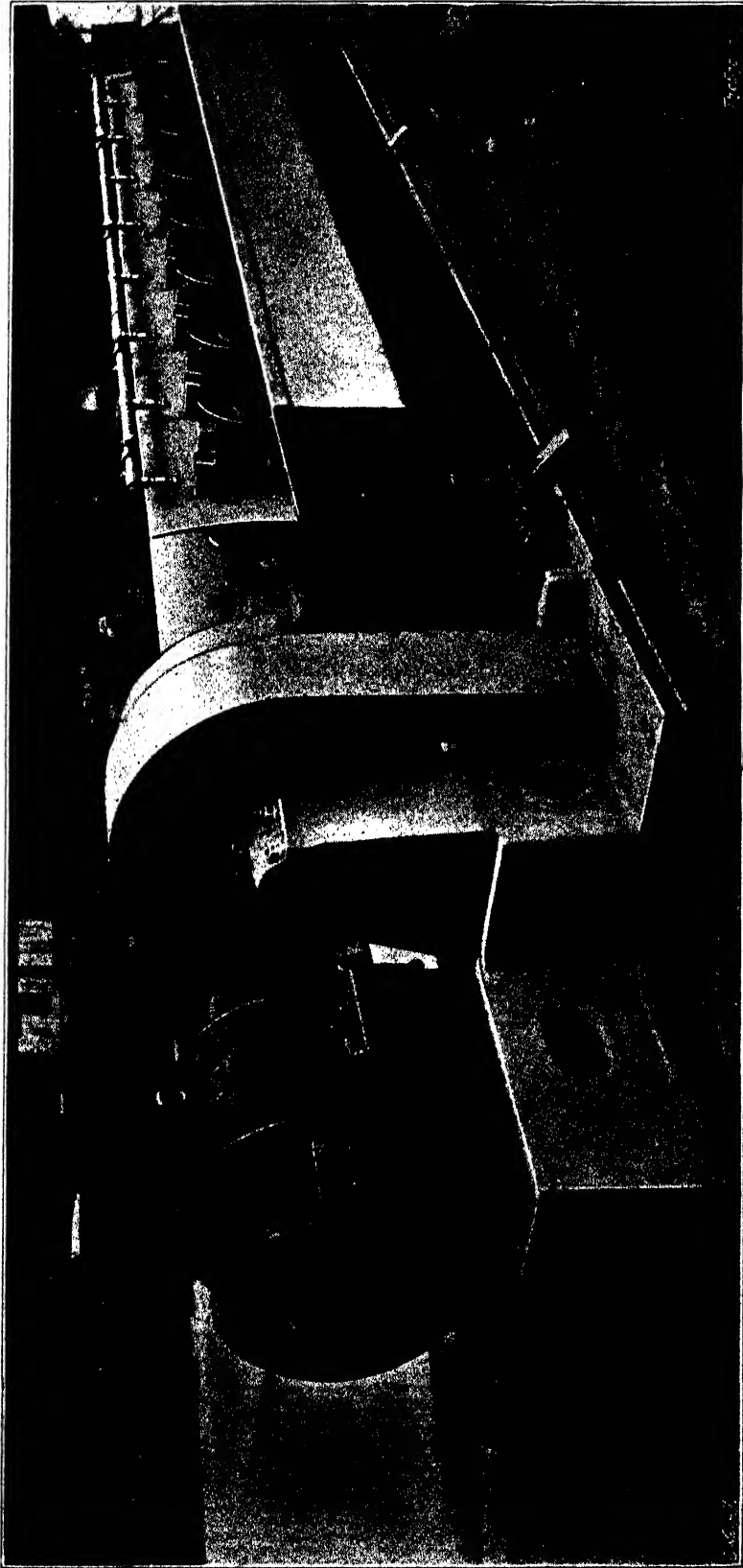

FIG. 38.—NINE-HOLE CONTINUOUS WIRE-DRAWING MACHINE—W. H. A. ROBERTSON.

CONTINUOUS WIRE-DRAWING MACHINES

A small but useful refinement introduced on the machines by Barron and Crowther is the arrangement of the swift for holding the undrawn wire. The vertical spindle on which the swift turns is hinged at the bottom, and it is connected with the belt striking gear or clutch of the machine in such a way that if the wire gets entangled on the swift the drawing block is stopped by the pull on the swift spindle. It is a simple expedient, but very useful, as if a coil does get fouled and the attendant is not handy, or if there be no automatic device, the coil will often be torn off the swift and quickly get bundled up against the die in an unravellable mass.

An obvious alternative to differential gearing as a means of accommodating the extension of the wire between the passes is to use blocks of progressively increasing diameters, and Figs. 35 and 37 show two Crossley machines adopting this principle, neither of which requires much explanation. In each case the wire is drawn simultaneously through two holes only.

In Fig. 35, it will be seen, the two diameters of block are provided on one spindle and are driven by a single set of gearing. The diameters of the block must naturally be chosen carefully, so that the peripheral speeds will be appropriate to the reduction of the wire in the two passes. Otherwise the wire will slip on one drum or the other and the rubbing will produce a flat on it. In the case of the machine shown in Fig. 37 blocks of different diameters are provided on separate spindles, and each has its individual drive. This machine is, of course, more adaptable in its output than is the single-spindle set. All the foregoing continuous machines are intended for dry drawing. That is to say, the wire is lubricated with soap or some such material.

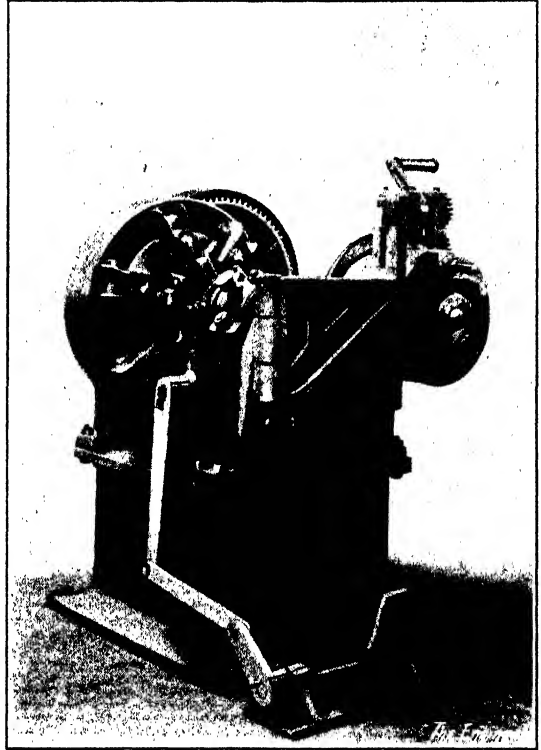

FIG. 39.—STRINGING-UP MACHINE—ROBERTSON.

For the continuous drawing of comparatively fine wires it is usual to use a liquid lubricant, which also serves the purpose of keeping the dies cool, and at one time stale beer was used almost universally for the purpose. The odour of this lubricant, especially after it has been in service some time, is most offensive and penetrating to the newcomer; but most modern wire-drawing establishments use one or the other of several proprietary lubricants which are odourless and are quite as effective as beer grounds. Some very popular solutions for this purpose are made by Stansfield Bros., Limited, of Stanton Works, Heaton Street, Cleckheaton.

A continuous three-hole wire-drawing machine, with a 12 in. block, for wet drawing, by G. Crossley, is illustrated by Fig. 36. It follows a rather exceptional arrangement. There are, it will be noticed, two spindles, one of which carries an ordinary block. This illustration, by the way, shows very clearly how the first turn of wire runs down, from the clamp at the top, to the bottom of the block. On the other spindle there is another shallow block having two different diameters, arranged in a tray which is filled

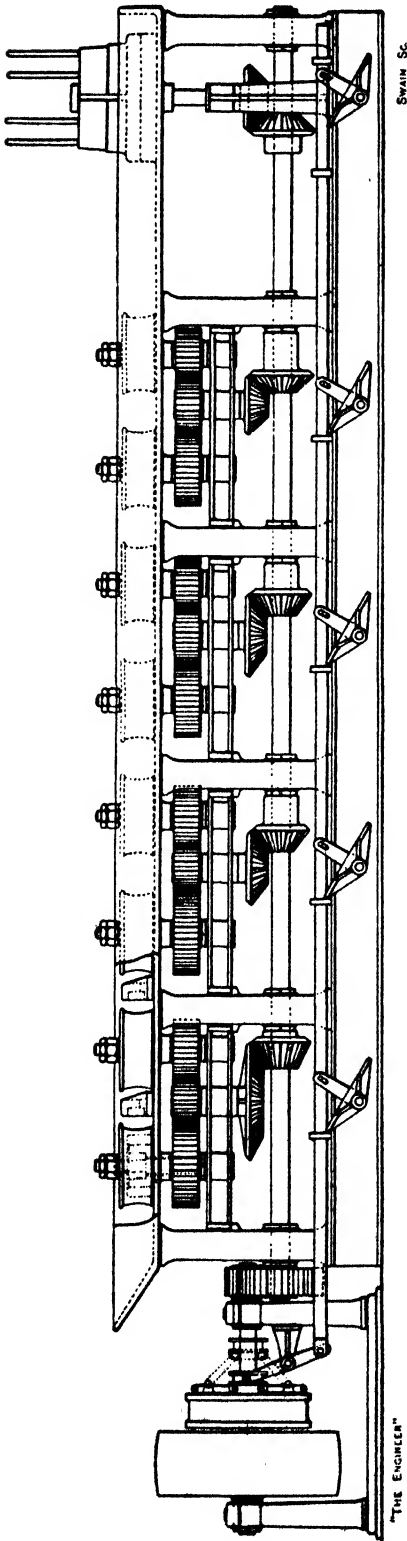

FIG. 40.—VERTICAL-ROLL CONTINUOUS WIRE-DRAWING MACHINE—DAVID BRIDGE.

with the lubricant. The wire first comes through a die just outside the tray, then round the smaller diameter of the first block, over a guide pulley, through the second die, round the block again on its larger diameter, and then through the third die to the second block. The lead of the wire, it will be seen, is such that the swifts can be arranged directly behind the machine, and a long row of blocks can consequently be accommodated on a bench without crowding one another.

It is possible to draw continuously through more than the three or four dies mentioned so far, specially when working on copper, as that material does not require annealing so frequently as does steel, and some machines have as many as sixteen passes; but are used only when the wire has already been reduced very considerably in gauge. There is, however, an intermediate "tandem" class of machine, such as that shown in Fig. 38, which will take rolled copper rods, $\frac{5}{16}$ in. or $\frac{1}{4}$ in. in diameter, and reduce them to, say, No. 16 S.W.G. in one operation.

The machine illustrated, which is made by W. H. A. Robertson and Co., Limited, of Lynton Ironworks, Bedford, has nine passes, and, as will be seen from the engraving, the drums, which take the place of blocks, are mounted on horizontal spindles. The wire is drawn successively through the dies by these drums, and is finally taken off by a block at the extreme end of the machine. The drums are all of the same diameter, and as a consequence each one has to be driven at a higher speed than its neighbour on the left, in order to accommodate the extension of the wire. All the eight drums are driven off a horizontal shaft, running along the back of the machine, by bevel gearing, and the ratios of the gears are so arranged as to give the necessary increase in speed. The finishing block is mounted on a vertical spindle, and is driven off a transverse shaft by means of a pair of bevel wheels, with a friction clutch interposed in the drive. The whole of the gearing is machine-cut, and the bevel wheels are of cast steel. The main drive is from a 50 horse-power electric motor, mounted on an extension of the bed-plate, through an intermediate reduction gear and a friction clutch.

CONTINUOUS WIRE-DRAWING MACHINES

The die holders are of cast steel and are designed to take standard, four-hole, chilled cast iron dies. They are cored out to provide a channel for the lubricant, and above each there is a cock connected with the lubricant supply system, which is worked by two pumps. The lubricant is also allowed to accumulate in the trough—seen running along the front of the machine—until it reaches to about one-third of the height of the drums, so that the whole drawing system is very thoroughly cooled and lubricated.

Running along the front of the machine at the floor level there is a shaft provided

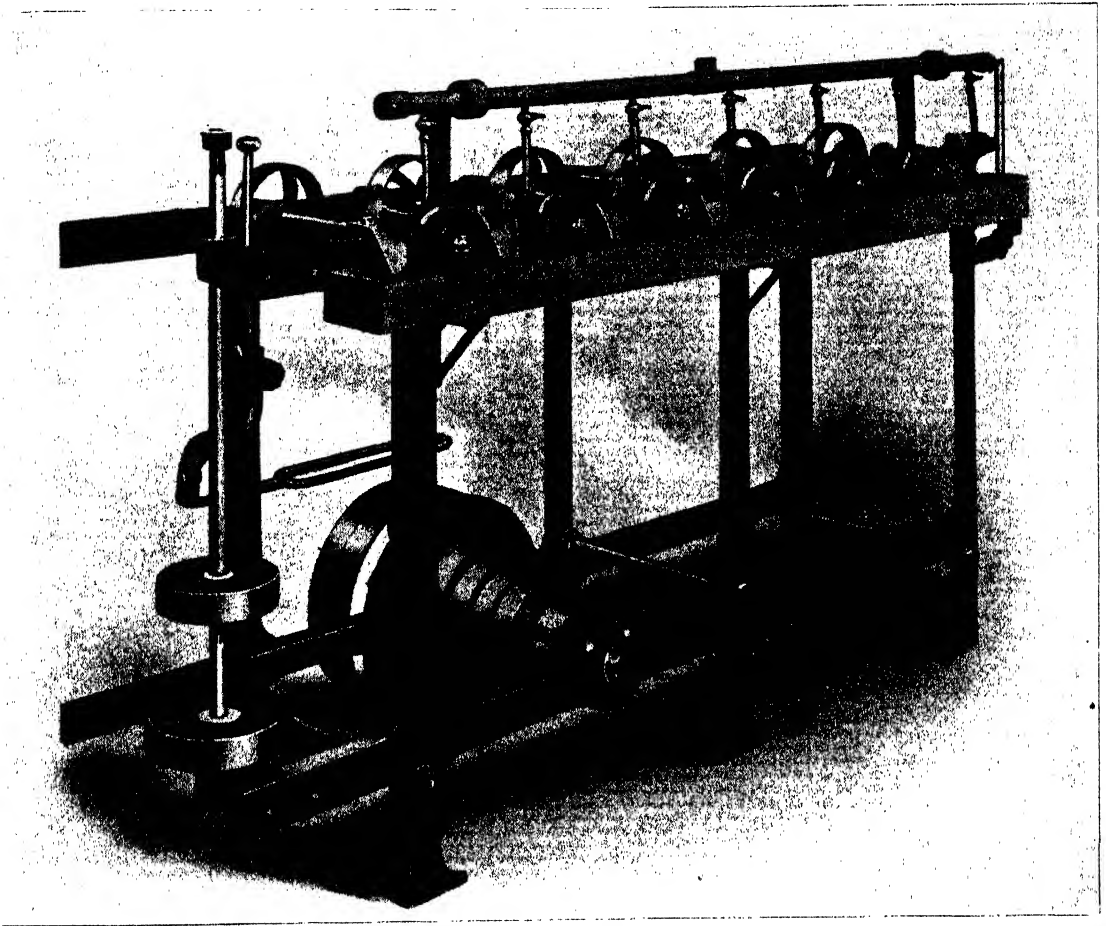

FIG. 41.—SEVEN-HOLE CONTINUOUS MACHINE—G. HATTERSLEY.

with several pedals and connected with the main clutch, so that the attendant can stop and start the machine without going its whole length to reach the clutch lever. All the gearing is covered with strong sheet guards. The block on this machine is large enough to take 2 cwt. of wire.

It will be readily appreciated that the operation of threading the wire through all the dies and the general preparatory work on such a machine as that just described would occupy an inordinate amount of time if carried out in the same way as with a single block. The machine would, in fact, be non-productive for something like half its life. For this reason, the "stringing-up" machine—illustrated by Fig. 39—has been evolved.

BRITISH WIRE-DRAWING AND WIRE-WORKING MACHINERY

This machine is fitted up at the finishing block end of the main machine, and is driven by belt from the transverse shaft already mentioned. It is equipped with a friction clutch, and thus can be started and stopped independently of the drawing machine.

The process of stringing-up is carried out as follows: About 15 ft. of the coil to be threaded is unwound and a point formed on the end by the hand-operated pointing rolls which can be seen on the right above the block. The first (largest) die of the tandem machine is then put on the die holder, and the point on the end of the coil put through. This point is then gripped by the grips on the front of the block. It should be mentioned, by way of explanation, that the front of the block is separate from the body, and is driven by a ratchet which can be released so that the front can be revolved backwards to bring the grips right up to the die holder. When the wire is secured in the grips, the machine is set in motion, and about twenty coils drawn

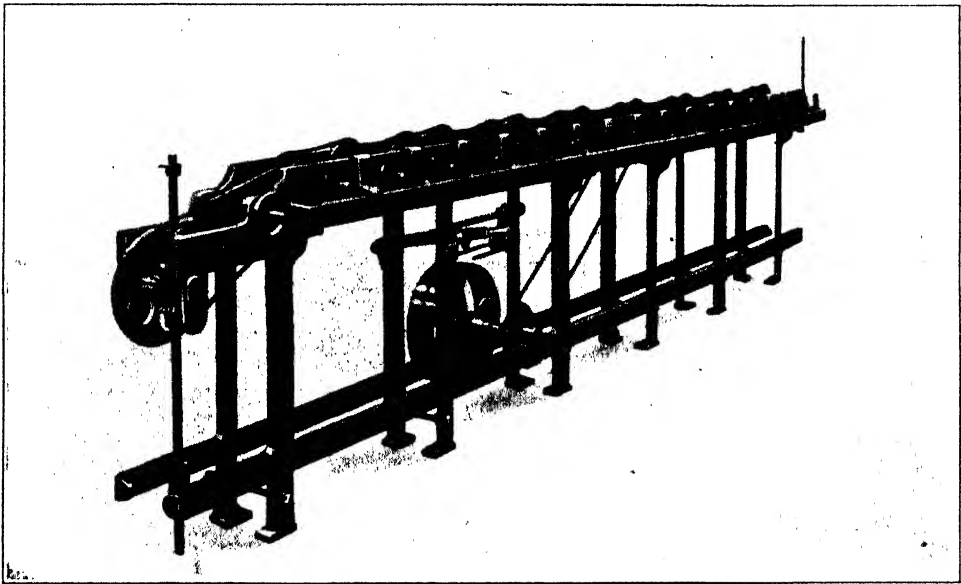

FIG. 42.—CHAIN-DRIVEN CONTINUOUS WIRE-DRAWING MACHINE—G. HATTERSLEY.

on the block. The machine is then stopped and the wire taken off the block, the second die of the tandem is put on the machine, and the length already drawn pulled through. Care is now taken to stop the drawing at such a point as to leave sufficient length between the first and second dies to provide for the requisite number of turns on the main drawing drum, and the distance between the die holders on the tandem. The remaining seven dies are dealt with in turn in like manner, and when they have all been threaded on, the coil is ready for the drawing machine.

The operation of stringing-up may appear at first sight rather complicated, but with a little practice it can be easily carried out by the ordinary type of labour employed in wire mills in considerably less time than that taken by the preceding coil in running through the tandem. A few minutes will suffice to put the new dies carrying the wire on the machine, so that practically no time is lost.

The stringing-up machine is strongly built to withstand rough usage, the bearings, particularly that in the loose pulley, being of very large proportions, and with adequate arrangements for lubrication. The die holder bracket and the clutch plate are of cast steel.

CONTINUOUS WIRE-DRAWING MACHINES

Another type of tandem machine, by Geo. Hattersley and Sons, Limited, of Keighley, is shown in Fig. 41, and is chiefly noteworthy on account of its indicating the preference of some wire drawers for belts, rather than toothed gearing, for driving the drums. It is claimed by them that the belt gives a smoother action, and that there is less liability of breakage of the wire when drawing very fine gauges. Otherwise the principle of the machine is the same as that already described. The finishing block is mounted on the belt-driven spindle on the left of the illustration. The machine illustrated, it will be noticed, has six spindles, but they are made in various

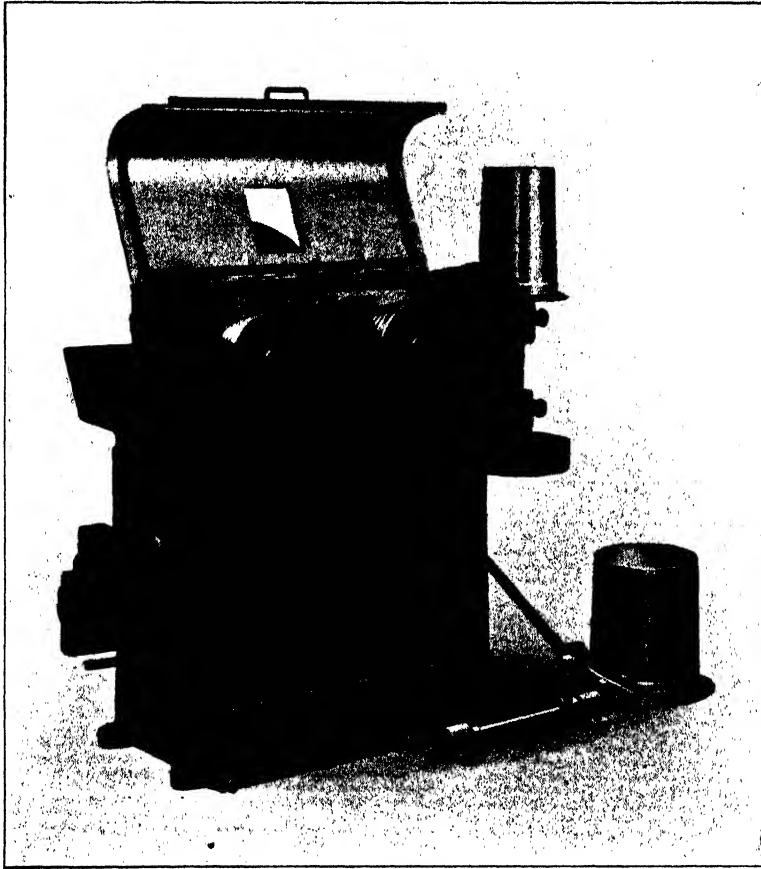

FIG. 43.—CONTINUOUS MACHINE FOR FINE WIRES—ROBERTSON.

sizes with up to sixteen spindles. It is worthy of mention that Messrs. Hattersley claim to be the makers of the first continuous wire-drawing machine made in this country.

Yet another alternative system is illustrated by Fig. 42. It represents a machine, also made by Messrs. Hattersley, and, as will be seen, all the driving is effected by chains, with the exception that the spindle for the block is driven by a rope. Each of the drawing spindles drives the succeeding one at an appropriately increased speed. The machine is also noteworthy through having the unusually large number of sixteen die blocks, so that a very great reduction in the section of the wire can be made at one pass. It is, of course, only intended for fine gauge wire.

Another variation of the same general principle is illustrated in Fig. 40, which

BRITISH WIRE-DRAWING AND WIRE-WORKING MACHINERY

represents a machine made by David Bridge and Co. It will be observed that the drums are mounted on vertical spindles, and driven in pairs by bevel gearing. The spur gears are, of course, so proportioned as to give a regular increase in the speed of the drums. The drums are open at the bottom to provide accommodation for annular weirs which prevent the drawing lubricant from leaking away through the spindle bearings.

For drawing down wire from No. 16 gauge to, say, No. 26, a different and more compact type of machine, such as that shown in Fig. 43, is usually employed.

In the case of the machine illustrated, which is by Robertsons, there are ten dies, almost invariably of diamond, arranged alongside one another in the bracket seen between the two horizontal drums. Of these two drums, that on the right is positively driven by belt from the rear, while that on the left is a guide or idler. Each of the drums has a series of grooves of diminishing diameter, so that they appear more or less as cones, with the small diameter towards the back. The main drawing drum is built up of nine cast iron sections, each faced with a hardened steel ring. The wire takes a turn round each groove in succession, and between each turn is threaded through a die. Finally, it is taken off by the block on the right, which is driven by belting and bevel gearing from the main shaft.

Lubricant is supplied to the hollow interior of the die bracket by a pump arranged at the back of the machine, and comes up through holes in the front of each die that direct it on to the wire just as it enters the die. The overflow passes over the conical drums, down into the trough below, and immerses the lower part of the drums. A sheet metal cover is arranged to come down over the top of the machine and prevent the lubricant splashing overboard. The base of the machine includes a tank large enough to hold about 40 gallons of lubricant.

The finishing block can be of any required size within reasonable limits, and the block bracket is arranged to slide laterally, so that various diameter blocks can be used and readily brought into line with the finishing die holder. The gearing is so arranged that the pulley on the bottom of the block spindle is always the same diameter as the block, which prevents any mistake as to which pulley should be used. It will be readily understood that, in addition to the ease of interchange of blocks by having a belt drive, the cushioning effect of the latter tends to prevent the breaking of fine wires.

The speed at which these machines run naturally depends upon the gauge of the wire being drawn. That illustrated in Fig. 43 is arranged to run at about 950 ft. per minute on the finishing block, while a very similar machine, by Barron and Crowther, works at 1,000 ft. per minute with No. 26 gauge wire, or 500 ft. per minute when drawing No. 20 gauge.

A machine by David Bridge and Co. embodying the same general principles, but in which the block is driven by toothed gearing, instead of belting, is illustrated by the line drawing Fig. 44. The machine shown has ten dies, nine on the bracket and one just before the finishing block, but it is made with provision for up to sixteen reductions in one operation. It is usual, however, to use three cones and two die brackets when such a large number of passes is made on one machine, as otherwise the drums become of unwieldy length and are consequently liable to vibrate.

If wire is drawn down to very fine gauges, say, below 48 S.W.G. (0.0016 in.) in copper, or even below 0.008 in. in hard steel, it becomes curly and cannot be taken off an ordinary block, as so soon as it is released it flies into a hopeless tangle. As a consequence, the finishing block must be dispensed with for these very fine gauges, and the

CONTINUOUS WIRE-DRAWING MACHINES

wire is wound directly, as it is made, on to a spool. If it has subsequently to be annealed the spools are of metal, otherwise they are of wood.

A machine for this class of work, by Robertsons, is illustrated in Fig. 45. The body of the machine is very much the same as that shown in Fig. 43, except that all the running parts are made as light and easy running as possible, while ball bearings are used for the idle pulleys and main spindle.

In the place of the finishing block used in drawing moderately fine wires, there is a spindle for carrying the bobbins on to which the wire is wound. This spindle is provided with mechanism, shown plainly in Fig. 45, that lays the wire evenly on to the bobbin throughout its length and thickness.

The spooling gear is driven by the pulley A, which is connected with the main driving shaft by belt, and on the same spindle there are the pulley B and cone C. The pulley B drives the cone E through a crossed belt, and against this cone there is pressed the rubber roller H, which is carried in the swinging frame G. The bobbin on to which the wire is wound is fixed between the plates F F. and is consequently

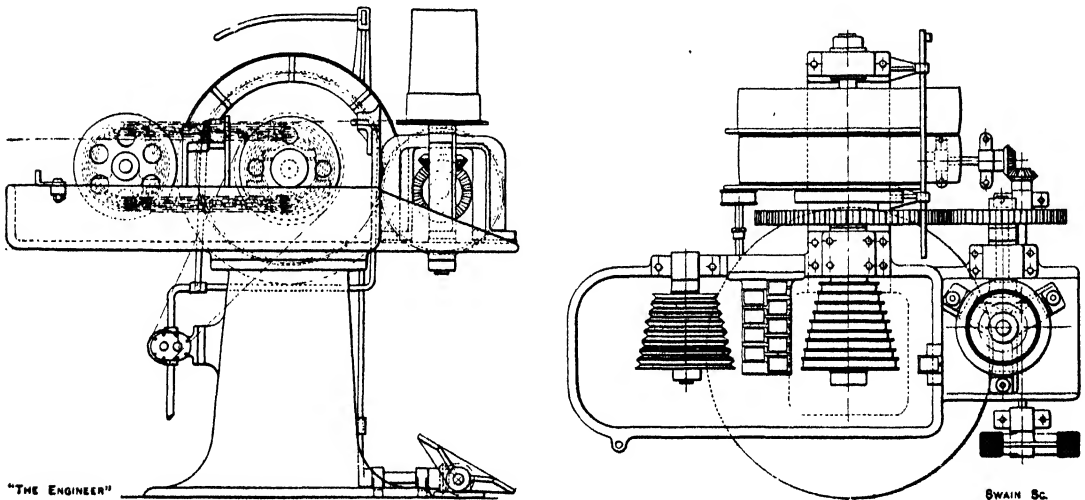

FIG. 44.—CONTINUOUS WIRE-DRAWING MACHINE—DAVID BRIDGE.

driven by the rubber roller H. The cone E is driven by its shaft through a feather, and can be moved endways by means of the lever J, so that the speed of the spool can be adjusted to suit the increase in diameter as the spool is filled up. A light spring is provided to press the two plates F F together and thus hold the spool, and the thrust of this spring is borne on a ball washer. Another spring is used to keep the roller H up against the cone E, but there is a catch for holding it out of engagement when the spools are being changed.

The wire is guided on to the spool by the pulley N, which is traversed to lay the wire in an even layer. The traverse is effected by the heart-shaped cam L, which is driven by the worm gear K and speed cones C C¹, so that variations in the diameter of the wire can be accommodated. The cam gives motion to the rocking lever O, through the push rod M, and thence to a slide carrying the guide pulley N. The length of the stroke of the rocking lever can be adjusted, by means of the movable fulcrum P, to accommodate different lengths of spool.

On account of the light nature of the spool driving gear, it cannot be expected to

BRITISH WIRE-DRAWING AND WIRE-WORKING MACHINERY

provide sufficient tension to draw the wire off the machine, and as a consequence the drum Q is provided for the purpose. This roll is of hardened steel, and is driven by belt from the pulley D. The wire passes round this drum on its way to the guide pulley N.

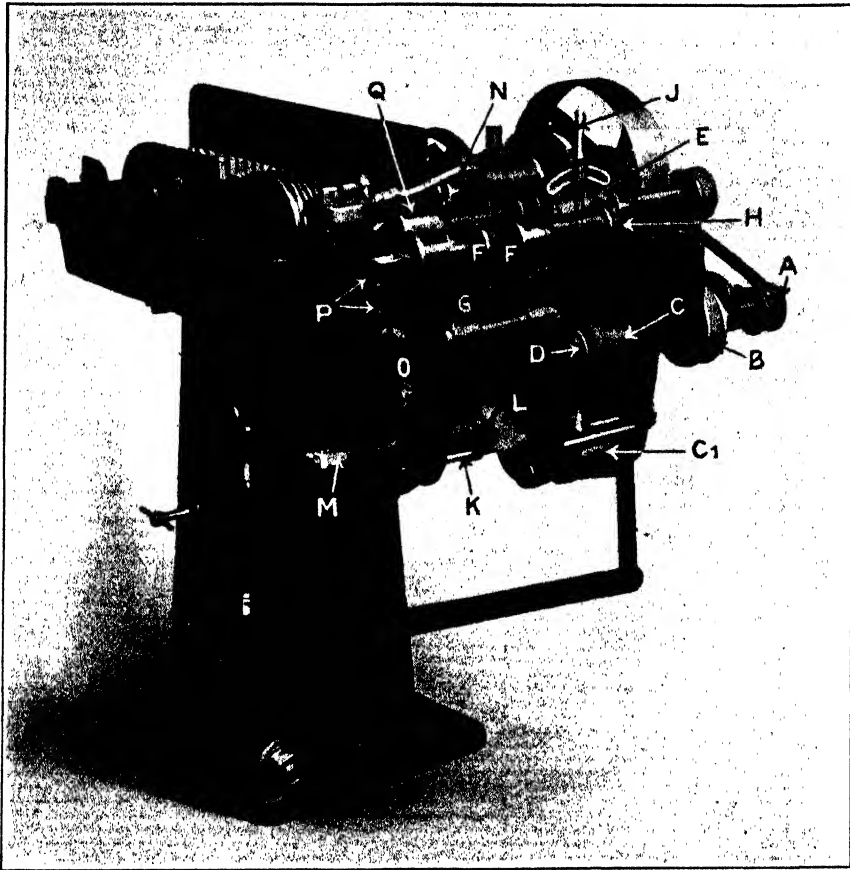

FIG. 45.—CONTINUOUS MACHINE FOR VERY FINE WIRES—ROBERTSON.

It will be appreciated that it is possible to vary both the width of coil laid on to the spool and the speed as it is filled up, and although the result is quite satisfactory for general wire-working practice, the makers do not pretend that the spool is wound so perfectly as, say, cotton reels, which are filled by much more elaborate machinery.

CHAPTER VI

STRAIGHTENING AND CUTTING-OFF MACHINES

FOR many purposes in the wire trade, such, for instance, as scratch brush making, needle making, and a host of other services, it is necessary to make the wire quite straight and to cut it off to dead lengths. Both these operations are generally performed on a single machine, several types of which are illustrated in the following pages.

The most commonly used class of straightening and cutting-off machine, known

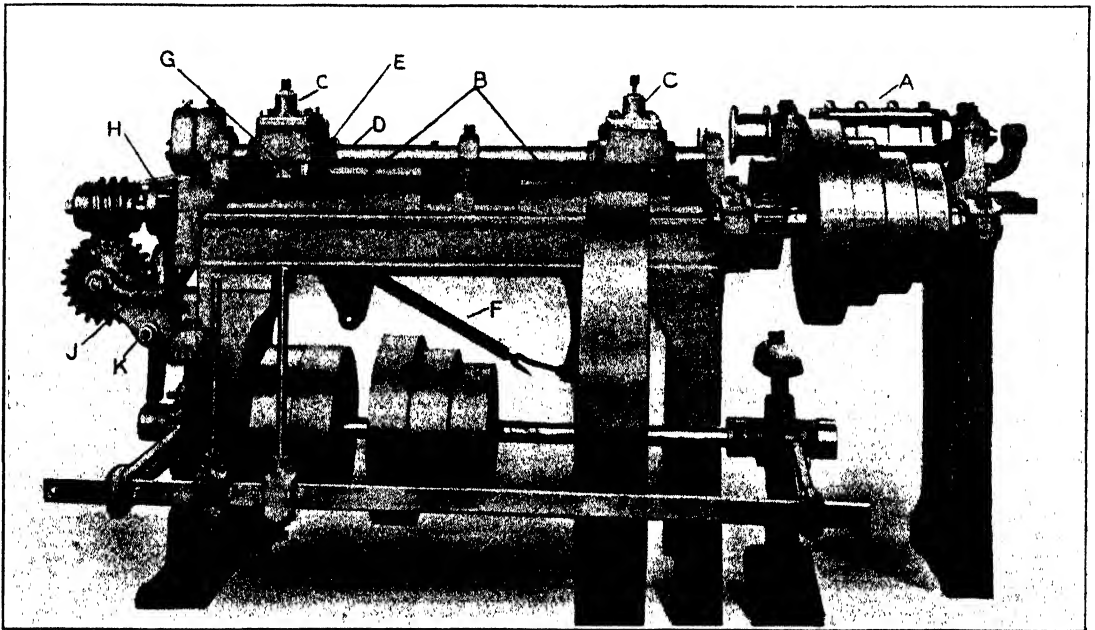

FIG. 46.—STRAIGHTENING AND CUTTING-OFF MACHINE—G. CROSSLEY.

as the cam machine, which is made by a large number of manufacturers in this country, is that illustrated by Fig. 46. The actual machine represented in the engraving is by G. Crossley, of Cleckheaton, and is intended for handling wires of from, say, No. 5 to No. 12 gauge. The view shows the back of the machine, and on the right there can be seen the straightening device A.

The straightener, or spinner, as it is generally called, is a hollow spindle, which is driven at a speed of 1,000 revolutions or so a minute, depending on the gauge of the wire being worked on. The wire is led directly from a swift, through a fairlead, and then through the centre of the spinner. Along the length of the spinner there is a series of cross-pieces, numbering from four upwards, and the wire is threaded through renewable bushes in these cross-pieces. The holes in the bushes do not, however, coincide exactly with the axis of the spinner, but are adjusted by the nuts, which can be plainly seen in Fig. 46, so that they are alternately on opposite sides of the

BRITISH WIRE-DRAWING AND WIRE-WORKING MACHINERY

centre line. The result is that as the wire is drawn through the spinner, and prevented from rotating by the grippers, it is rapidly bent backwards and forwards through a small angle. In this way all the kinks are taken out of the wire, and it emerges perfectly straight. It will be obvious that the setting of the spinner so as to produce straight wire is a skilled job, and it takes some time to acquire the art, as different classes of wire have quite different characters, and must be humoured accordingly.

For some kinds of wire the fixed bushes of the spinner are replaced by small wheels while others have pegs, between which the wire is threaded, and the means of adjustment are equally varied, but the broad principle remains the same.

In the case of section wires, it is not, of course, possible to use a rotary straightener, as the shape of the section would be destroyed, and it becomes necessary to use a set of fixed rolls, such as those shown in Fig. 47.

Reverting to Fig. 46, the cutting-off mechanism is driven by a separate belt from that for the spinner, through the stepped cone on the right. This pulley drives a longitudinal shaft through cut gearing. On the longitudinal shaft there are two big drum-

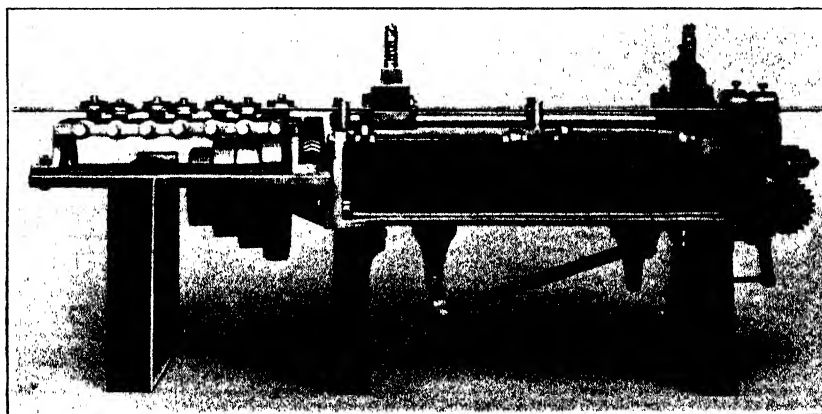

FIG. 47.—ROLL TYPE STRAIGHTENER—G. CROSSLEY.

like cams B B, which give its name to this type of machine. The bed of the machine beneath the cams is formed as a trough to contain oil for lubricating the cams.

The cams have to perform two functions. One is to slide the grippers C C along the slide bar D, and the other is to make the grippers grip the wire at the proper time. The longitudinal sliding motion is effected by a double scroll-shaped step cut round the circumference of the cam. A small roller E bears against the rear of this step, and pushes the gripper forward. The return stroke is effected by the spring F, stretched between two levers connected with the two grippers. The return stroke is not, however, violent, as the roller E, bearing against the reverse side of the cam, restrains the gripper. The two cams are set with their working faces opposite one another, so that one gripper travels to the left as the other goes to the right. It will thus be seen that if the wire is alternately seized by the two grippers, it will be steadily drawn forward, with only a very slight check at the end of each stroke of the cams.

The acts of gripping and releasing are effected by a variation in the diameter of the cam surface. That is to say, the cylindrical part of the cam at the bottom of the helical step is of two diameters on opposite sides of the cam. The part of larger diameter corresponds with the length of scroll actuating the outward stroke of the gripper,

STRAIGHTENING AND CUTTING-OFF MACHINES

while the smaller diameter follows the return half. The two diameters are connected by sloping faces

Bearing against this part of the cam there is a finger G, with a rounded end. The finger is fixed to the main casting of the gripper, and tilts it about the round slide bar D, according to the immediate diameter of the cam upon which it is riding.

The form of the actual grippers is best shown in Fig. 48, which is a front view of a machine for cutting-off wires up to $\frac{1}{2}$ in. diameter. Each gripper comprises a lower block, sliding on the front of the bed-plate, which is held between checks on the gripper casting in such a manner that it is moved longitudinally, but is not affected by the rocking action of the casting. The upper gripping block is also free to slide, but is held down by a heavy spring and yoke across the top of the casting. Both the blocks are of hardened cast steel. It will be seen that when the gripper casting is tilted by the finger G, Fig. 46, the two blocks will be forced together, and will nip the wire under the influence of the spring. The various operations are, of course, so timed that the wire is held by the grippers during the outward stroke and released on the return.

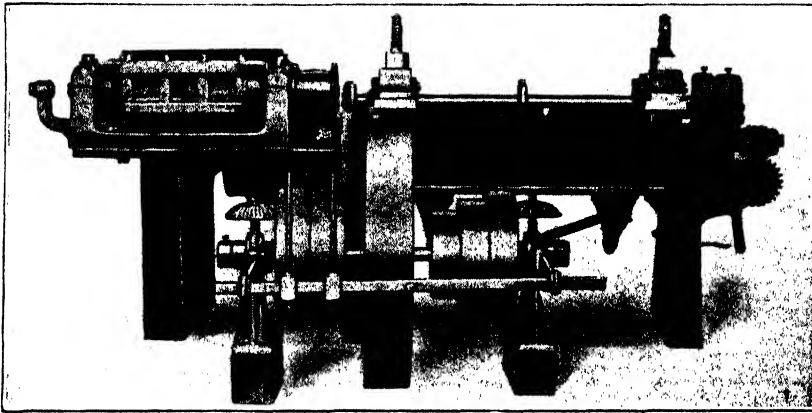

FIG. 48.—MACHINE FOR CUTTING HEAVY WIRE—G. CROSSLEY.

As the length of stroke of the cam is fixed when the machine is made, it becomes necessary to make some provision for cutting-off wires of a length less than the stroke of the grippers. This requirement is met by stopping the grippers on the return stroke at any predetermined point, by means of stops on the front of the bed, which can be seen in Figs. 47 and 48. These stops can be adjusted to any position on a screw reaching from end to end of the bed.

It may be as well to point out here that the roller E must always ride round the point where the stepped scroll on the cam changes from the forward to the reverse stroke, but on the return stroke it may be checked by the stop, which has only to resist the force of the spring F while the cam goes on rotating, and the roller crosses the valley between the two sides of the scroll. In this way the stroke of the grippers can be adjusted to any desired extent, but there comes a limit when the time lost in crossing from one side of the cam to the other makes the arrangement unprofitable, and a shorter cam must be adopted.

The cutting-off gear is shown in Fig. 46, from which it will be seen that a worm is keyed on to the end of the cam shaft and drives a worm wheel. Just inside the worm there is a cam H for operating the cut-off tool. The cut-off mechanism is best shown in Fig. 48, and takes the form of a pair of dies, through which the wire passes. One of the dies is rocked about a trunnion to shear off the wire.

BRITISH WIRE-DRAWING AND WIRE-WORKING MACHINERY

If it be required to cut off only short lengths of wire—within the length of the scroll cams—it is a simple matter to arrange the cam H to operate the cut-off at each revolution, and a wire is delivered at each stroke ; but it is sometimes necessary to make lengths beyond the stroke of the grippers, and then the cut-off must be put out of action until the requisite length of wire has been fed forward. It is for this purpose that the worm and worm wheel on the end of the shaft are provided.

Between the rocking arm of the cut-off and the cam H there is interposed a distance piece J of such a thickness that when it is in position the cut-off makes a full stroke at each revolution of the cam. If, however, the distance piece is retracted, the cam is free to rotate without working the cut-off. Thus to make a cut at every stroke, the distance piece is locked against the cut-off lever. For longer pieces of wire the distance piece swings about the pin K, and is pulled clear by a spring. In order to bring the distance piece into position for cutting off, a series of tappets is provided on the face of the worm wheel, see Fig. 48. As these tappets come round they push the distance piece forward, and the cam then works the cut-off. The tappets are slipped into holes



FIG. 49.—MACHINE FOR CUTTING TWO WIRES SIMULTANEOUSLY—G. CROSSLEY.

in the worm wheel from the back and are kept in place by a perforated guard plate, so that it is a very simple matter to adjust their spacing to suit the length of wire to be cut.

The machine illustrated by Fig. 49 is similar to that already described, except that it is provided with two rotary straighteners, so that two wires can be cut simultaneously. Sometimes even three spinners, for three wires, are fitted. The cut-off tools have, of course, to be modified to accommodate the extra wires. The machine shown in this illustration is also provided with a double reduction gear for driving the cam shaft.

A totally different and novel type of cutting-off machine has recently been perfected by Mr. J. Thompson, of Brighouse, Yorks., and is illustrated by the engravings, Figs. 50 and 51, while Fig. 52 serves to represent the essential working parts.

The object aimed at by Mr. Thompson in designing his machine was to get a truly continuous action regardless of the length of wire being cut, so that there would be no lost time, and that the output would be correspondingly increased when cutting short pieces, while the wire would not be damaged by standing in the spinner during the time when it was being cut off. For this reason the cam driven feed was abandoned,

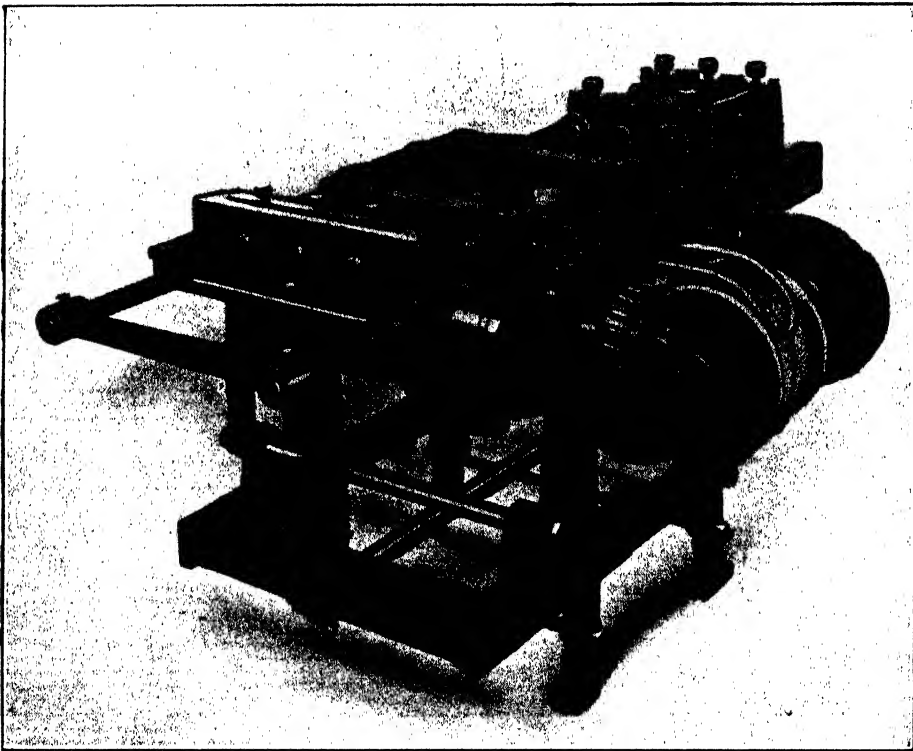
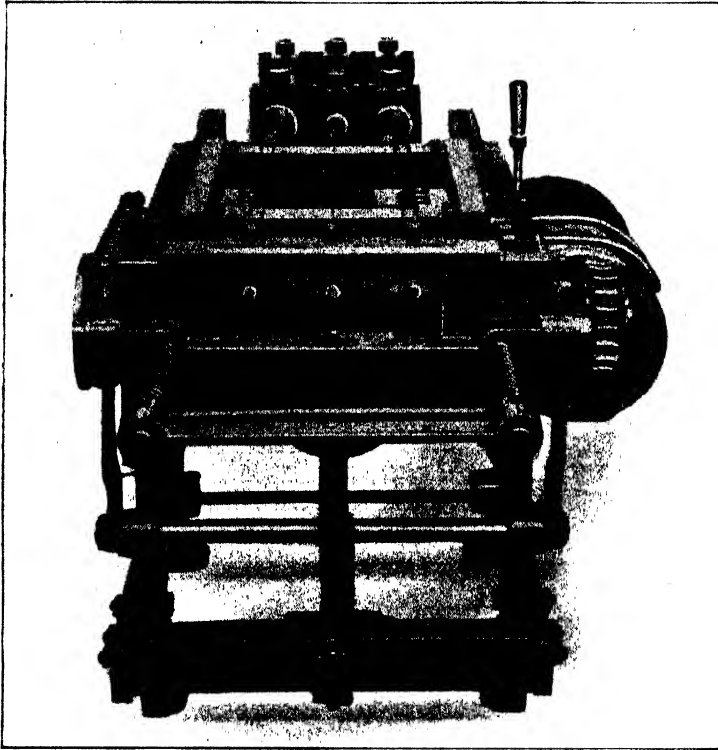

FIGS. 50 AND 51.—CONTINUOUS-FEED STRAIGHTENING AND CUTTING-OFF MACHINE—
J. THOMPSON.

BRITISH WIRE-DRAWING AND WIRE-WORKING MACHINERY

and in its place there is a pair of continuously running chains. These chains are marked A in Fig. 52, and run round a pair of large sprockets which are driven from the belt pulley through worm gearing. Spanning the two chains, to which they are fastened, there is a set of stretchers B B for carrying the gripping devices.

The machine illustrated is intended for handling three wires simultaneously, and

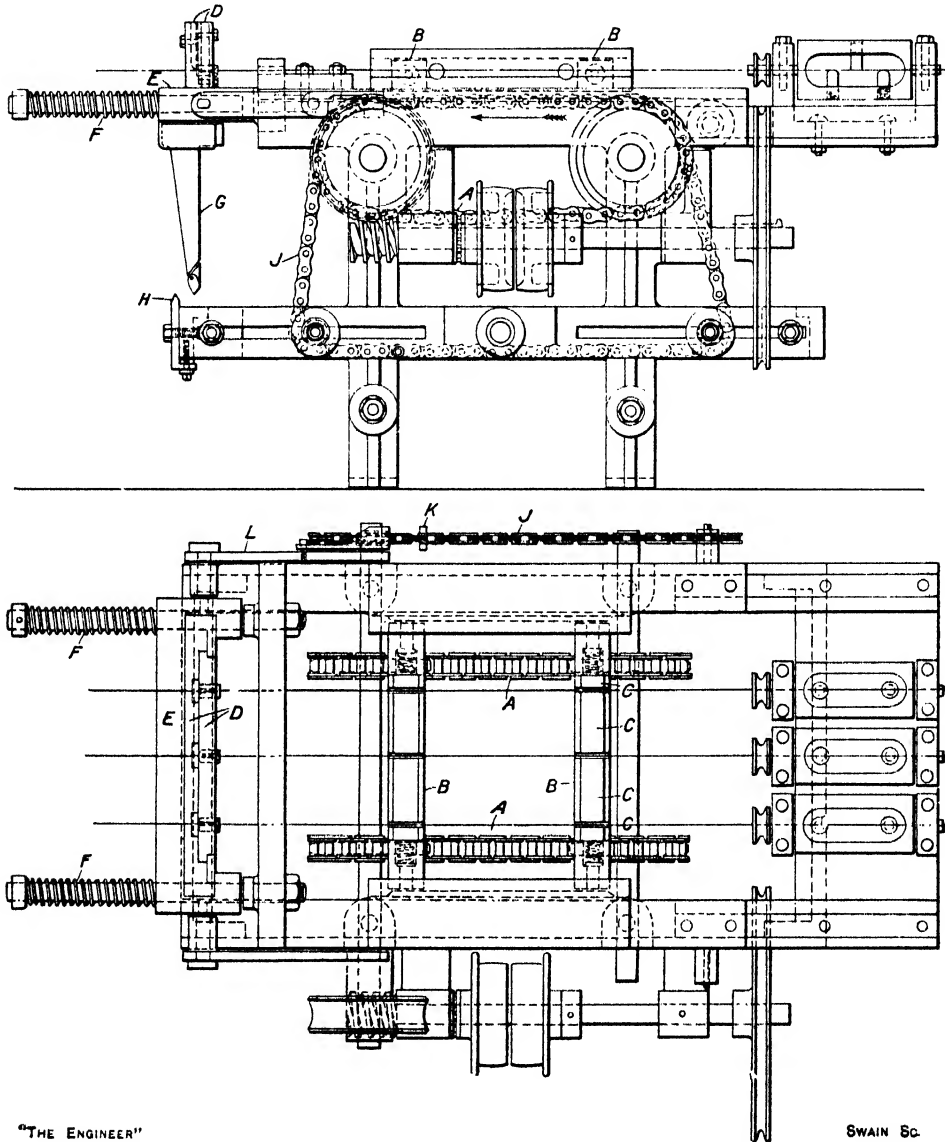

FIG. 52.—CONTINUOUS-FEED CUTTING-OFF MACHINE—J. THOMPSON.

is consequently provided with three sets of grippers, which take the form of blocks C C C sliding transversely in the stretchers. The gaps between the blocks are where the wires are gripped, and the whole group is pressed together by springs and plungers at the ends of the stretchers. As the stretchers pass along the upper horizontal length of the chain, the plungers are pressed inwards by guides on the main frames and the wires are gripped, but at each end of the straight the guides are cut away and the wires

STRAIGHTENING AND CUTTING-OFF MACHINES

are released again. There are sufficient stretchers to ensure that the wires are always gripped at one spot at least, and there is consequently a continuous feed.

As there is no check in the movement of the wire, it becomes necessary to use a flying shear for cutting off, or the wire would be buckled as it was cut. The shearing blades *DD* are mounted in a carriage *E*, which slides horizontally on guides *FF*. One of the blades is moved vertically to cut off the wire by means of the lever *G*. As the carriage *E* is pushed forward with the wire, in a manner described later, the lower end of the lever *G* catches the projection *H* and is rocked about a fulcrum at the top, so that the shearing tool is pushed up and the wires are cut off. The return stroke is effected by the springs on the guide rods *F*, and during this movement a trigger on the end of the lever *G* rides over *H* so that the cut-off is not operated on this stroke.

It will be readily appreciated that the length cut off depends on the relation between the travels of the chains *AA* and of the carriage *E*. The two parts are interconnected in the following manner :—

On one side of the machine there is a chain *J*, which runs over sprockets similar to those for the chains *AA*, and is keyed to the same shafts. It also runs over some idle pulleys, so that its length may be varied, but it always runs at the same speed as the other chains. The chain *J* is provided with lugs *K*, at any desired intervals, which, on coming round, drive the carriage *E* forward through a pusher *L*. The rocking shaft and levers shown in the engravings, Figs. 50 and 51, but not included in the drawing, ensure that the carriage has a truly parallel motion. It will be seen that the maximum length of wire which can be cut is the length of the chain *J*, which Mr. Thompson puts at 30 ft., while by closely spacing the lugs *K* lengths as short as 3 in. and odd fractions can be made.

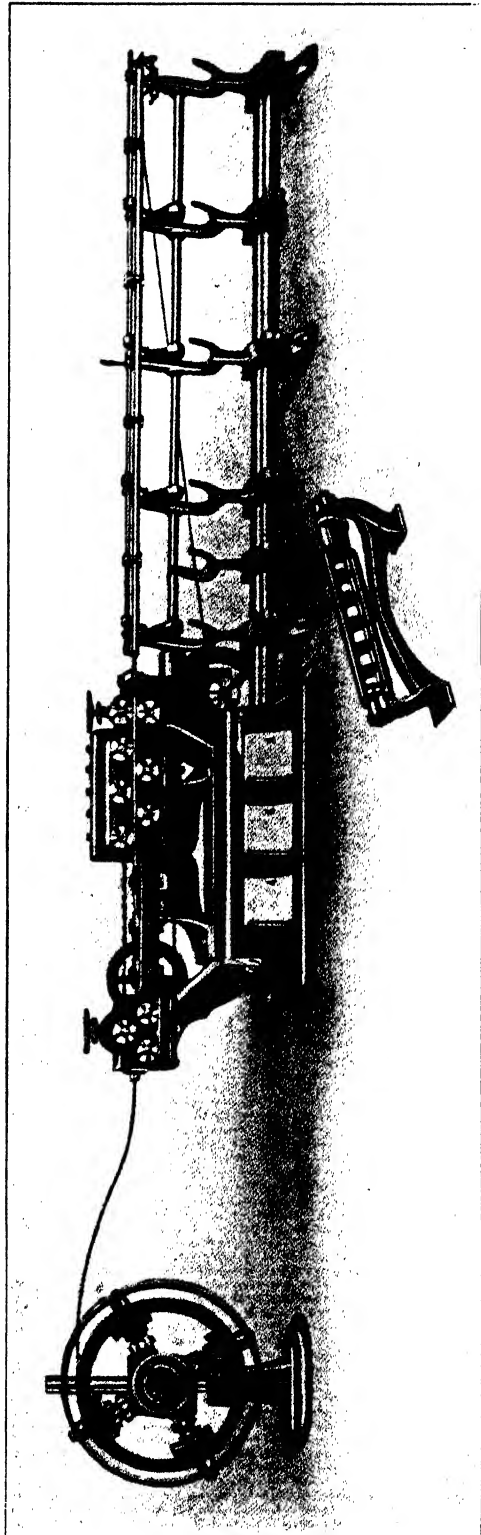

FIG. 53.—ROLL-FEED STRAIGHTENING AND CUTTING-OFF MACHINE—A. ROBINSON.

BRITISH WIRE-DRAWING AND WIRE-WORKING MACHINERY

The machine illustrated will take wire from No. 11 gauge downward, and the output is at the rate of 140 ft. a minute. All the bearings, with the exception of those for the spinners, are ring oiling, and the spinners have ball bearings. A smaller machine of the same type is also made, and takes four wires of from No. 18 gauge down to No. 24 gauge, at the rate of 190 ft. a minute, while a third machine for heavier wire is being brought out.

There is another general type of cutting-off machine, but it is almost entirely confined to handling heavy stock, such as $\frac{1}{2}$ in. stuff and upwards. Such a machine, by A. Robinson and Co., of Brighouse, Yorks., is illustrated by Fig. 53. As shown in the engraving, the machine is fitted up with a set of roll straighteners for section

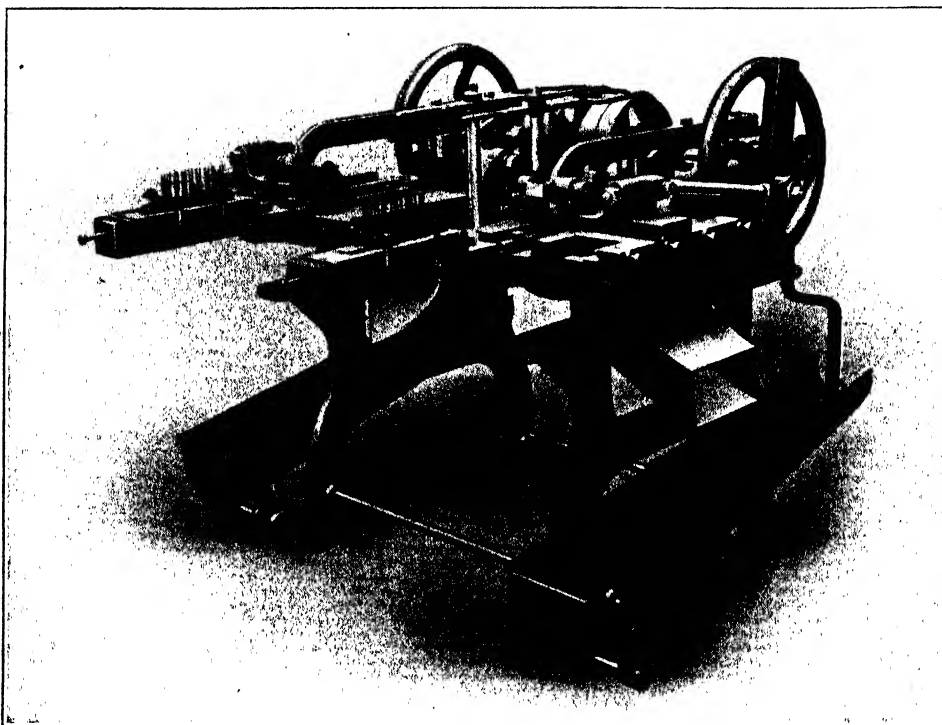

FIG. 54.—HIGH-SPEED STRAIGHTENING AND CUTTING-OFF MACHINE—E. WHITE.

wire; but the rolls can be removed and replaced by the spinner in the foreground when round wire is being dealt with.

One of the peculiarities of these machines is the use of a pair of rolls, seen at the right-hand end of the head, for feeding the wire forward. Rolls are not, of course, quite positive in their feed, so each length of wire is run out against a stop to determine its length before being cut off.

The wire coming from the feed rolls passes through the cutting-off dies, and is projected into a long tunnel, formed by a channel with a hinged lid. In this tunnel there is fixed the stop which determines the length of the wire cut. The stop is connected, by means of a wire which can be seen running diagonally from the end of the machine, with a clutch on the cam shaft for working the cutting-off lever. As a consequence, immediately the straightened wire strikes the measuring stop, the cam is set in motion and the wire is cut off. At the same time, the lid of the tunnel is opened by links connected with a horizontal shaft, that oscillates with the cutting-off lever,

STRAIGHTENING AND CUTTING-OFF MACHINES

and the channel is tilted to throw the wire into the forked arms below, which provide a convenient means for making up bundles.

A form of cutting-off machine specially designed for the needle-making trade is illustrated by Fig. 54, from which it will be seen that the mechanism is quite different to those already described. The machine shown in the engraving is by Edward White, of Redditch.

For the purposes of needle-making it is not essential that the wires should be absolutely straight, as the first operation after cutting off is to anneal them, and after that they are straightened. On the other hand, the number of wires required to keep a needle factory fully occupied is very considerable, and may amount to somewhere about a million pieces a day. A high-speed cutting-off machine is consequently very desirable, and that shown in the illustration is capable of delivering about 650 wires a minute.

The wire is drawn between a series of straightening pegs, which are plainly shown

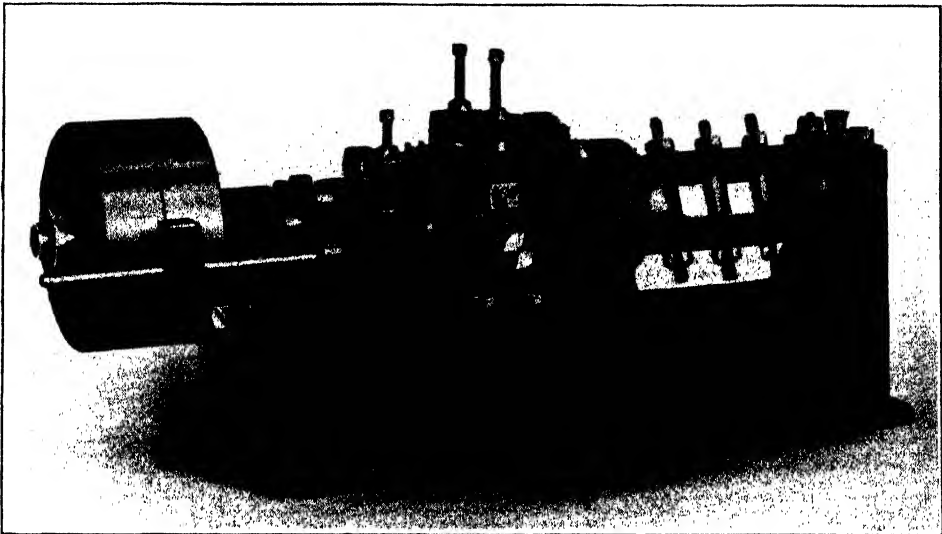

FIG. 55.—SMALL STRAIGHTENING AND CUTTING-OFF MACHINE—W. GRICE.

in the engraving, and is gripped by a pair of steel jaws on a slide, or crosshead. The jaws are opened and closed by a long lever running over the top of the slide, which is worked by a cam on the main driving shaft. At the end of this shaft there is an overhung slotted crank, which is used to work the slide through a connecting-rod. The stroke can, of course, be adjusted by moving the crank pin in the slot, and consequently any length of wire can be cut without loss of time, as is sometimes the case with cam-operated machines. With the machine under review a length of wire is cut for every revolution of the shaft, regardless of its length, so that the output depends only on the speed of the shaft. It should be mentioned, by the way, that the machine illustrated is double-sided, but each side has an independent drive. Thus the shafts have to run at about 325 revolutions per minute to give the output already mentioned.

The actual cutting off is effected by a tunnel die which is operated by a cam on the main shaft, and the wires, as they are cut off, fall down a shoot into a hopper alongside. The hopper is given a reciprocating movement so that the wires are all laid together with their ends even in a convenient manner for making up into bundles.

A very simple little straightening and cutting-off machine, by Wm. Grice and Sons,

BRITISH WIRE-DRAWING AND WIRE-WORKING MACHINERY

of Birmingham, is shown in Fig. 55, and needs little description. It will be noticed that the straightener is of the spinner type, and that the wire is drawn through it by a pair of rolls, driven through bevel gearing from the side shaft. After leaving the feed rolls, the wire is led through a pair of cutting-off dies, and runs out against a stop, which can be set according to the length of wire required. When the end of the wire strikes the stop, the cam which actuates the cut-off is brought into action, and the wire is cut off.

CHAPTER VII

WIRE FACTORIES

A VERY prominent place in the production of wire of all sorts is taken by the works of Richard Johnson and Nephew, Limited, at Bradford Ironworks, on the outskirts of Manchester, and some account of the establishment might have been included earlier in this work, as it could be made to embrace practically the whole art of wire-making.

At these works steel, bronze, and copper are converted from the rough billet or ingot into wire and more elaborate products, so that the whole of the many processes can be followed out ; but, in order to reduce the length of this chapter as much as

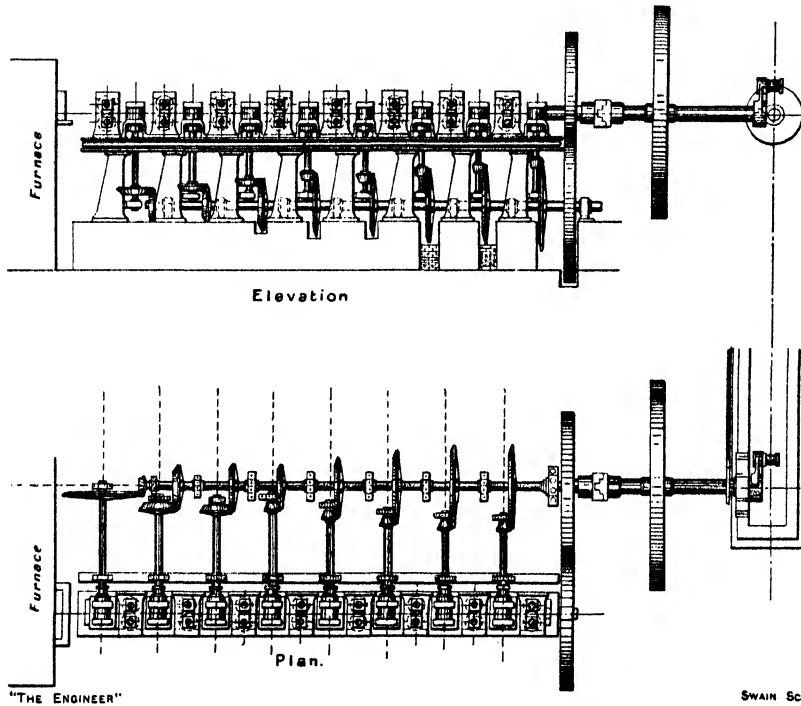

FIG. 56.—THE FIRST CONTINUOUS WIRE ROD MILL.

possible, it has been deliberately left until some of the phases of wire-drawing had been dealt with, so that processes which are more or less common practice might be passed over lightly. There are, however, several peculiarities about the plant and processes of the Bradford works, and it consequently seems better to group them into one chapter rather than tack them on to sections dealing with individual subjects.

The works are also noteworthy through being the birthplace of the continuous system of wire rod rolling, as it was there that Mr. Bedson's first continuous mill was erected, after a preliminary trial, run in private, in 1862. This mill, of which a drawing is given in Fig. 56, remained in continuous operation until 1884, and comprised a series

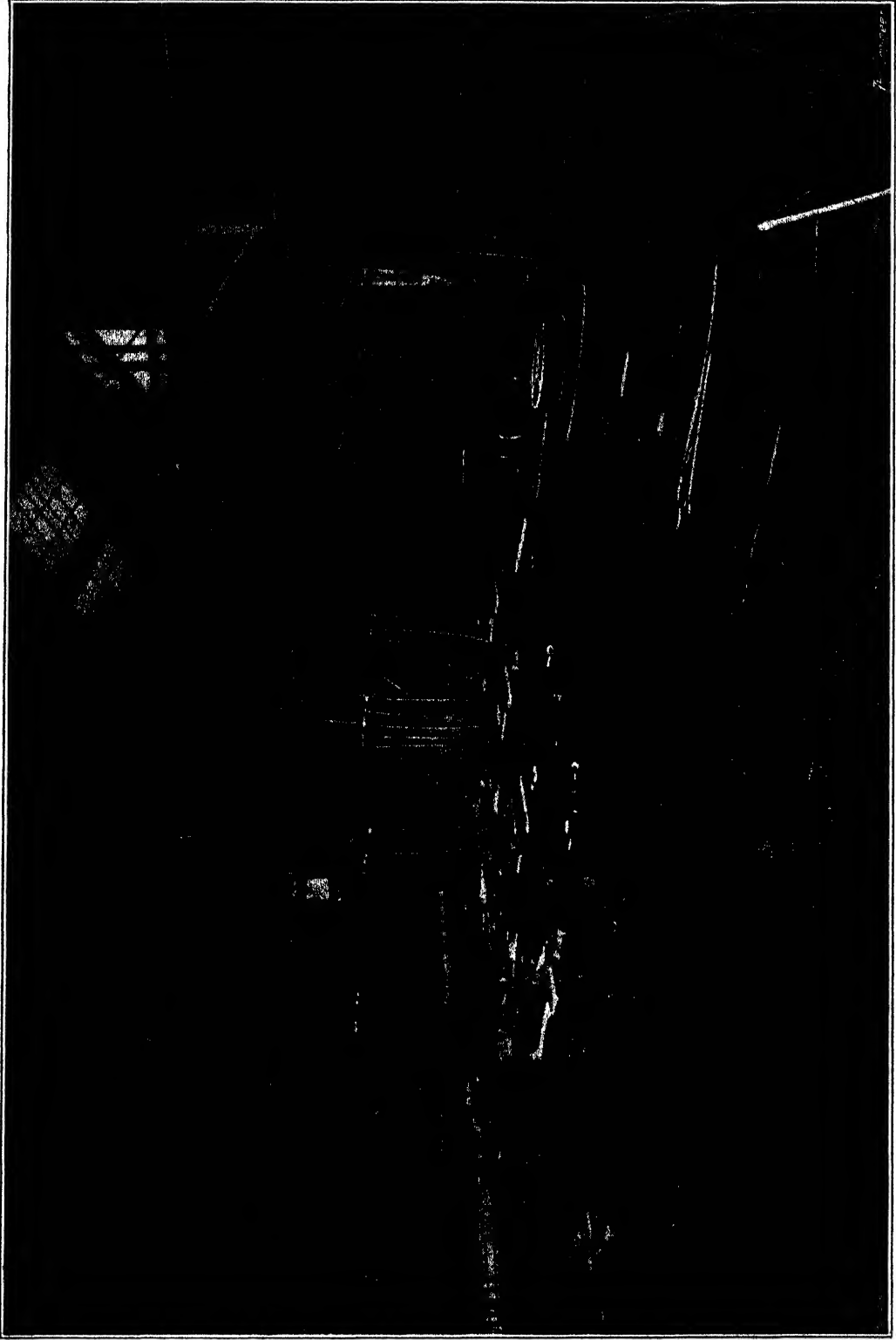

Fig. 57.—No. 2 Continuous Rod Mill at Bradford Ironworks.

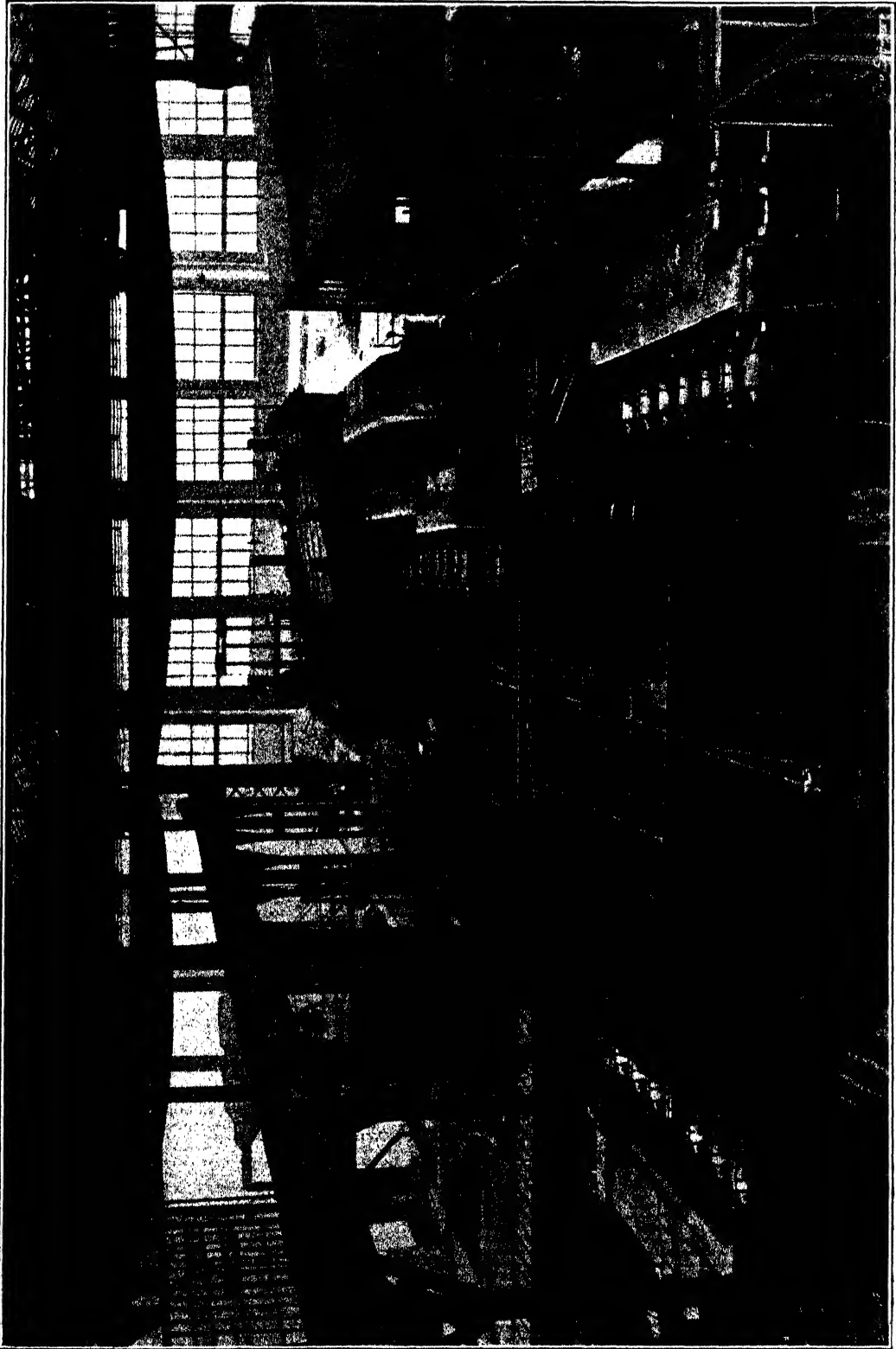

FIG. 58.—GENERAL VIEW OF NO. 5 MILL AT BRADFORD IRONWORKS.

BRITISH WIRE-DRAWING AND WIRE-WORKING MACHINERY

of sixteen pairs of rolls, arranged alternately vertically and horizontally. This alternate arrangement was adopted so that the rod, after having been deformed in one plane, was offered up to the next pair of rolls in the best position for further rolling. The mill was capable of rolling down billets 18 ft. long and $1\frac{1}{8}$ in. square, weighing 75 lb. each, into No. 5 wire rods. The output was about 20 tons in a turn of 10 hours.

In 1866 a second continuous mill was put down, and still remains in commission. This mill, part of which is shown in Fig. 57, also comprises alternate pairs of vertical and horizontal rolls all driven by spur and bevel gearing from a remarkable old steam engine. The mill rolls some 30 tons of rods per shift, but, like its predecessor, suffers from the drawback that mill scale falls down on to the gearing for driving the vertical

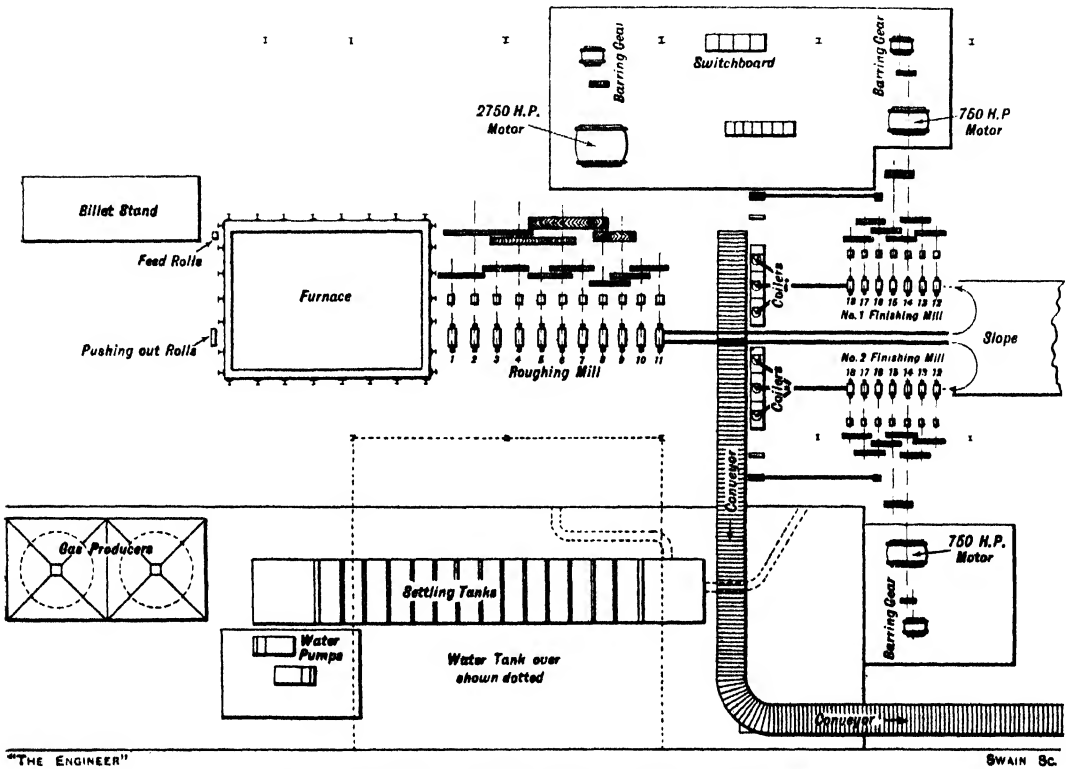

FIG. 59.—GENERAL ARRANGEMENT OF NO. 5 ROD MILL.

rolls, and naturally interferes with their running. It was, in fact, this trouble which led Mr. Charles H. Morgan, of Worcester, Mass., to adopt all horizontal rolls in his mill, an example of which is described in pages 7 *et seq.* Incidentally to the use of horizontal rolls, it became necessary to employ guides after each set of rolls which would turn the rod through 90 deg., and it is the maintenance of these guides which is one of the chief cares of the engineer in charge of a modern continuous wire rod mill.

Subsequent to 1866, several other mills were put down at the Bradford Ironworks, and finally, in 1916, the mill illustrated by the plan view—Fig. 59—and the engraving—Fig. 58—was constructed to the designs of Mr. J. P. Bedson. It follows the Morgan principle in having all the rolls horizontal, but is distinct in having all of them positively driven by toothed gearing. The mill has now been in operation for some time, but it is doubtful if it has ever had an opportunity for showing what it really can do, although

WIRE FACTORIES

it has produced as much as 1,250 tons of rods a week. The daily capacity is some 120 tons per $7\frac{1}{2}$ hours shift.

The scheme of the mill can best be followed with the aid of Fig. 59. The billets, which are 2 in. square by 28 ft. long, and weigh 364 lb. each, are heated in a furnace fired with producer gas. They are fed down the sloping bed of the furnace as they are heated, by hydraulic rams, and are pushed out at the lower end by a bar driven forward by a pair of rolls. The heated billets go, two at a time, into the roughing mill, which has eleven pairs of horizontal rolls. On emerging from the last pair of roughing rolls the rods are guided into two pipes which run between the two sets of finishing rolls. These pipes are very plainly shown in Fig. 58.

A man stationed at the outlet end of each pipe seizes the end of the rod as soon as it emerges, and, turning round, snips off the ragged end in a pair of constantly



FIG. 60.—LOOPING SLOPE OF NO. 5 ROD MILL.

running shears. He then enters the rod into the first of the finishing train of seven pairs of rolls. The rod is thus turned back on itself and is delivered towards the furnace again, with the result that a loop is formed as shown in Fig. 60. The loop extends down a slope, as in the case of a Belgian mill, and is tended by a lad to insure that it does not get entangled. "Turtlebacks," or fairleads, are fixed on the floor at intervals to insure that the back end of the rod is pulled clear of the last pair of rolls, and does not get chilled by the cooling water, which is constantly pouring all over the rolls. The finished rod is led to one or the other of a set of coilers, and when it has been coiled is tipped off, by hydraulic power, on to a conveyer, where it gradually cools down on its way to the dispatching yard.

The rolls in this mill are all 12 in. in diameter, and the finishing set runs at 900 revolutions per minute, so that the rod is delivered at a speed of about 32 miles per hour. With a red-hot rod travelling at this speed there is obviously great danger to the men if it should get out of control, and it is for this reason that the finishing trains of rolls are covered in by the wire grids shown in Fig. 58. The chief contingency that

BRITISH WIRE-DRAWING AND WIRE-WORKING MACHINERY

has to be guarded against is the "breaking out" of the rod, which may be caused by a ragged-ended rod sticking in the guides between the rolls. The concentration of energy involved in the high-speed rolling of wire rods may be gauged by the result of a break-out, as, if the rod then meets a rigid obstruction, it is piled up into a solid mass so thoroughly welded together that if the mass is sawn through no joints can be detected.

The drive for this mill is unique in so far as it is transmitted entirely through toothed gearing. The wheels have double-helical teeth, all machine cut, and are totally enclosed—see Fig. 58—so that they may be provided with a forced system of lubrication. The gears, naturally, are so proportioned that the rolls run at a speed increasing appropriately as the section of the rod is reduced. It has, by the way, been the custom of the American Morgan Company to advocate the use of a belt drive on

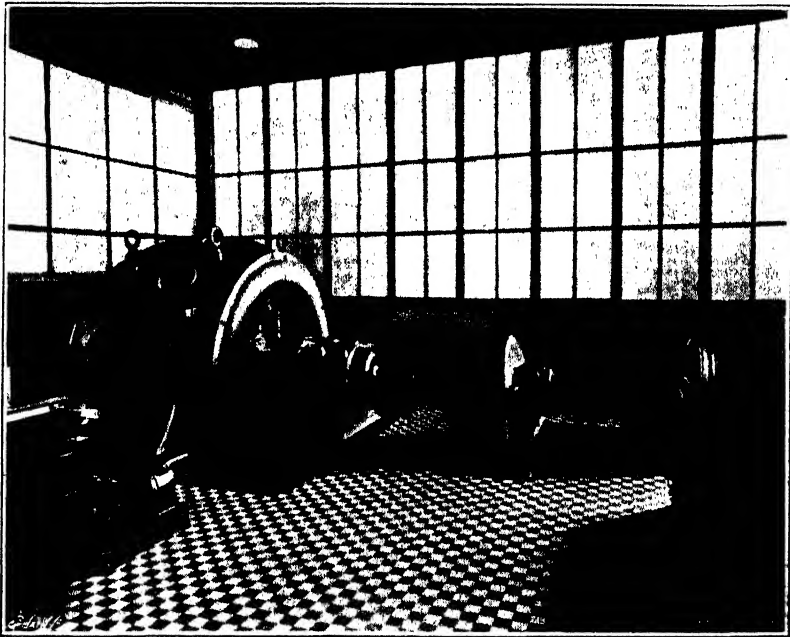

FIG. 61.—2,750 HORSE-POWER ROUGHING MILL MOTOR.

account of its supposed greater smoothness, but Mr. Bedson says that he has experienced no troubles through the positiveness of the toothed gear drive. There are flexible couplings between the gear shafts and the rolls themselves.

The driving power for the mill is supplied entirely by electric motors, by the English Electric Company. The roughing mill is worked by a 2,750 horse-power motor, of which a general view is given in Fig. 61. The smaller motor, on the right, and the reduction gearing, are for barring round the mill when getting ready for work. The main motor runs at 500 revolutions per minute and takes three-phase current, from the Corporation mains, at 6,600 volts and 50 cycles. The finishing trains of rolls are also driven by 6,600-volt motors, of 750 horse-power each, which run at 750 revolutions per minute.

A noteworthy feature about the electrical equipment of this mill is the elaborate system of underground passages, which not only provide accommodation for the cable connections to all the various motors, but are also used for supplying fresh, clean air directly underneath each unit.

WIRE FACTORIES

The operation of the mill is carried out from a control platform in the motor house, which commands a view of the whole plant. On this platform there are push buttons for starting and stopping all the motors, together with indicating lamps and ammeters.

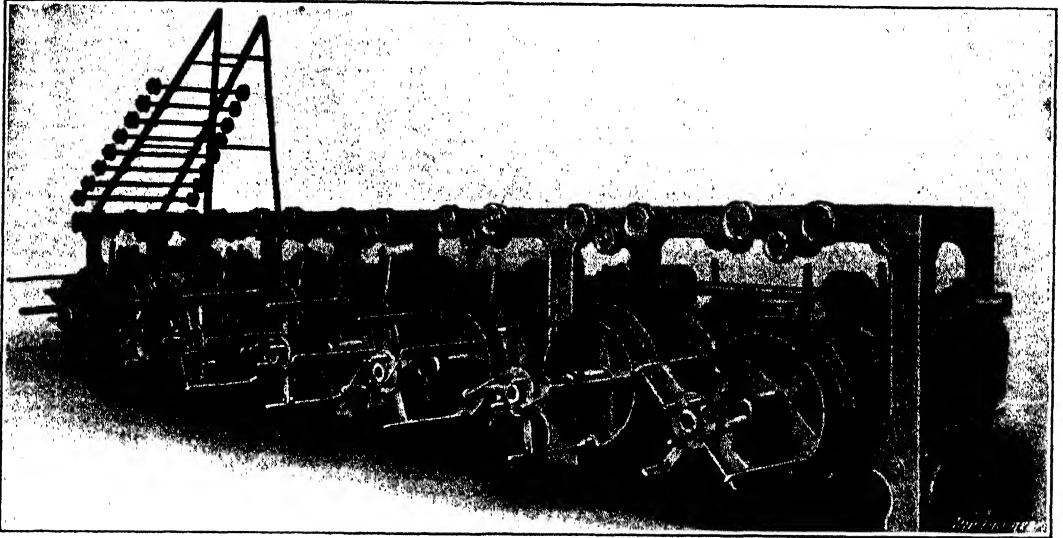

FIG. 62.—WIRE PATENTING FRAME.



FIG. 63.—WIRE ROD CLEANING DEPARTMENT.

The whole scheme has, in fact, been so developed as to centralise the control as far as possible, and to minimise laborious or dangerous work about the mill.

On reference to the plan of the works—Fig. 66—it will be seen that the conveyor, which brings the coiled rods away from the mill, delivers towards the cleaning house,

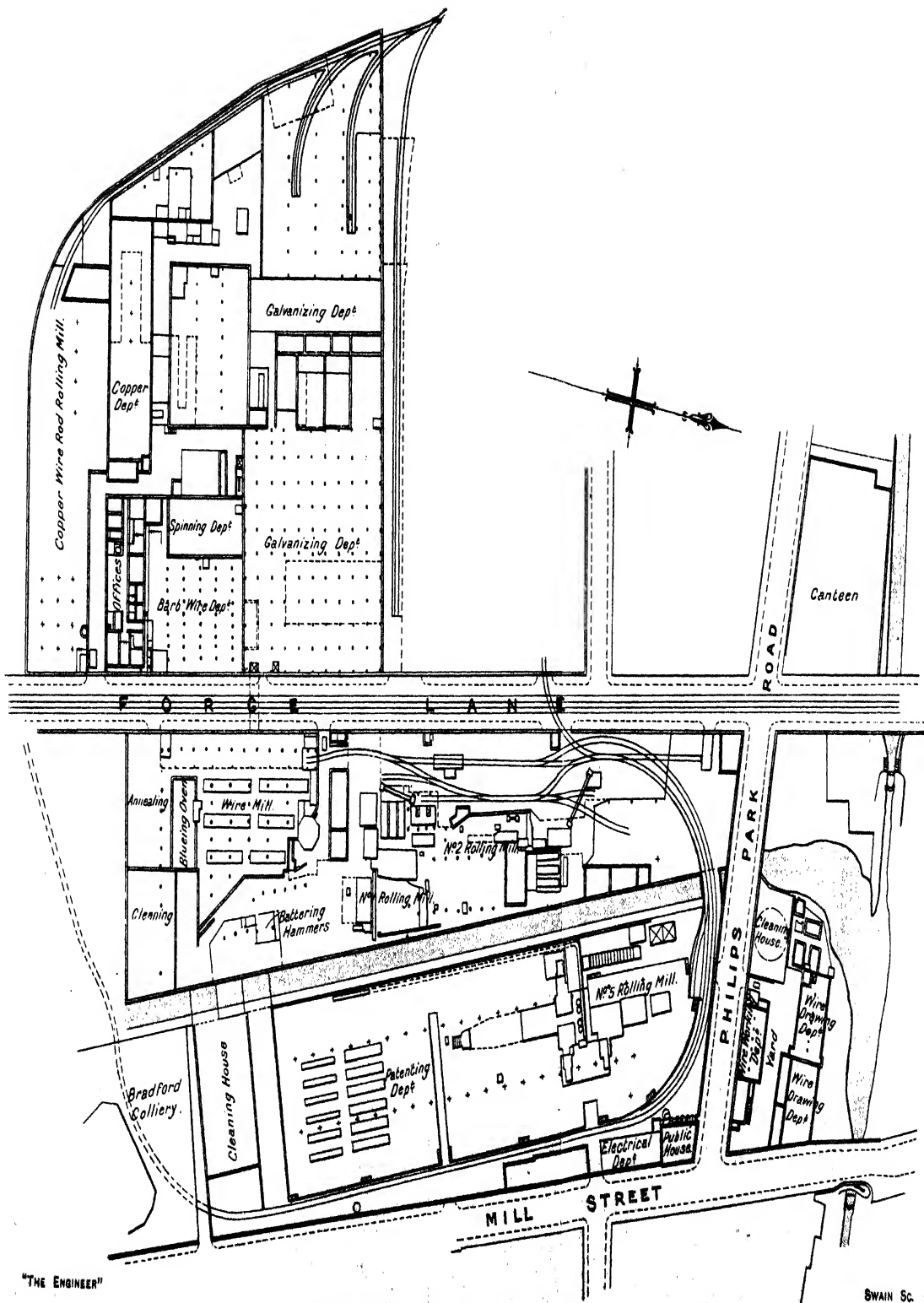

FIG. 64.—HEAVY WIRE-DRAWING DEPARTMENT.



FIG. 65.—PART OF THE GALVANISING DEPARTMENT.

where the rods are pickled and coated in the usual manner. The material is handled by a system of overhead runways and high-speed electric cranes, and the motors of these cranes are the only motors in the works which give rise to any anxiety, as they



"THE ENGINEER"

FIG. 66.—PLAN OF THE BRADFORD IRONWORKS.

SWAIN SC.

WIRE FACTORIES



FIG. 67.—BARBED WIRE DEPARTMENT.

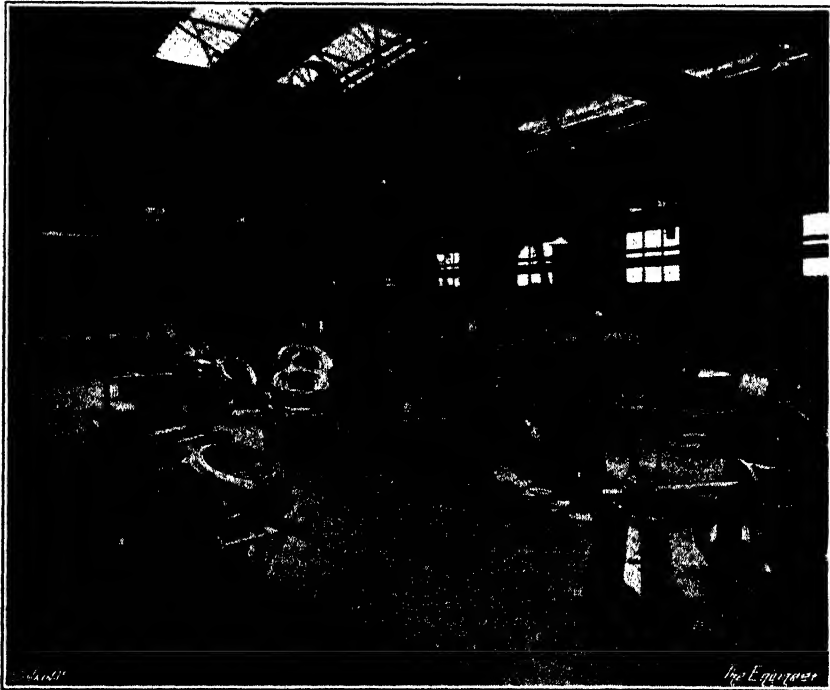

FIG. 68.—FINE COPPER WIRE SHOP.

have to work in an atmosphere heavily laden with acid fumes. It would, however, be very difficult to handle the large amount of rods—some 1,200 tons a week—by any

BRITISH WIRE-DRAWING AND WIRE-WORKING MACHINERY

other means. The engraving—Fig. 63—gives a good impression of the interior of the cleaning house. The rods are pointed by rotary swaging machines, and are then issued to the wire-drawing shops—see Fig. 64.

The general equipment of these shops needs no detailed description, as it follows orthodox practice. There are some 260 blocks all told, driven by electric motors and ranging in diameter from 30 in. downwards. The maximum speed for these blocks is 100 revolutions per minute, but when doing the more difficult work, such as section drawing, the speed is reduced to about 34 revolutions per minute.

In the patenting department there are half a dozen gas-fired furnaces of the scaling and non-scaling types.

There is some difference of opinion among wire drawers as to the relative merits

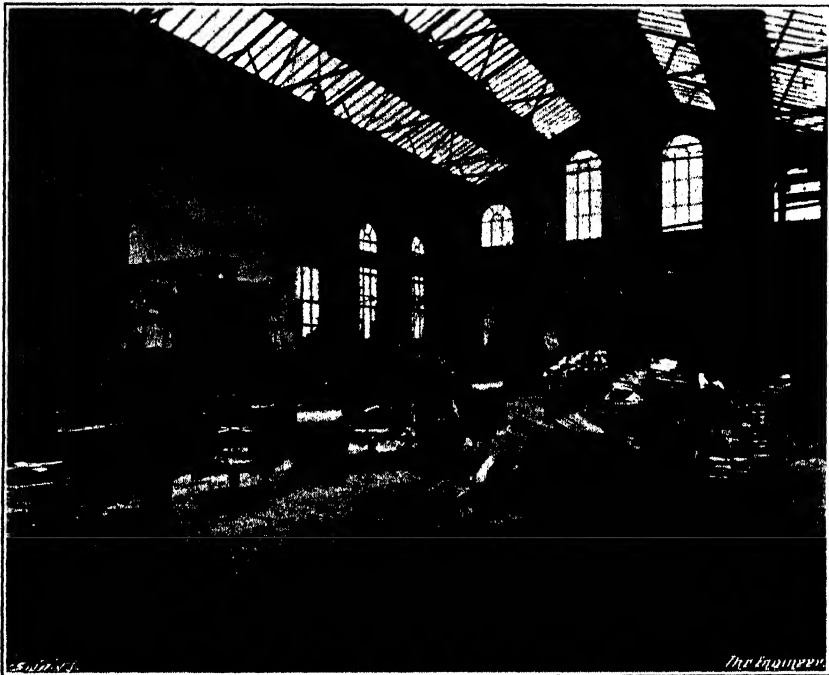

FIG. 69.—HEAVY COPPER WIRE SHOP.

of the two types of furnace, and it is based on a variety of reasons. The loss of metal has, for instance, to be set against the increased cost involved to prevent scaling and the value of the scale itself, while it is urged by some wire-drawers that the wire is actually improved by letting it scale, as the process removes the outer skin.

The patenting furnaces at the Bradford works have 10 tubes each for the passage of the wires, but the number naturally depends upon the gauge of the material being handled. The raw wire is held on a group of swifts at the inlet end of the furnace, and after having been patented is re-coiled on a patenting frame.

A patenting frame by George Crossley, of Cleckheaton, is shown in Fig. 62, from which it will be seen that a series of horizontal drums is driven, by worm gearing, off a longitudinal shaft. The drums are provided with clutches, so that they may be stopped individually for the removal of the coils of wire, while retractable stops are arranged to prevent the coils falling off prematurely. The wires coming from the furnace are led over guide pulleys on a gallows at one end of the machine, and then

WIRE FACTORIES

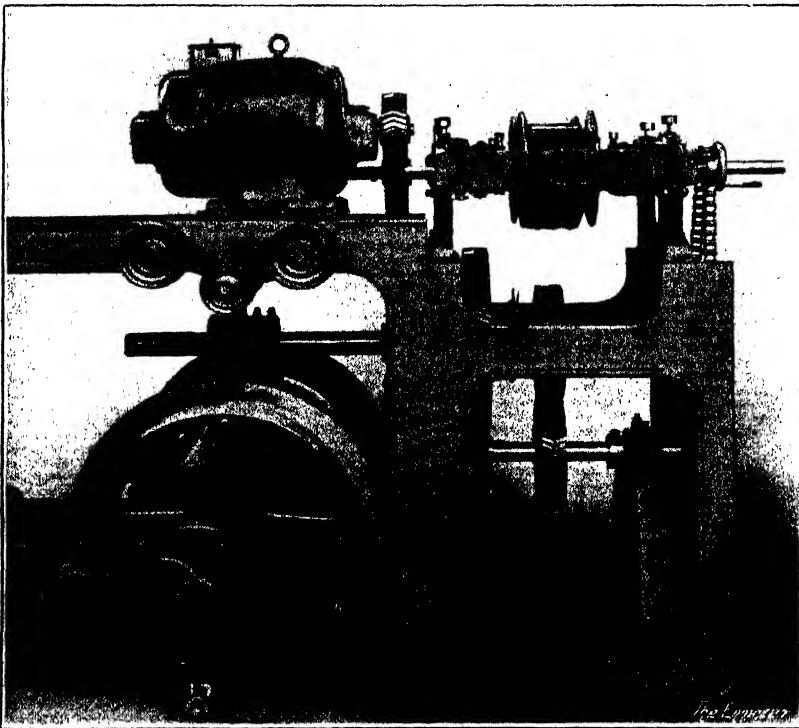
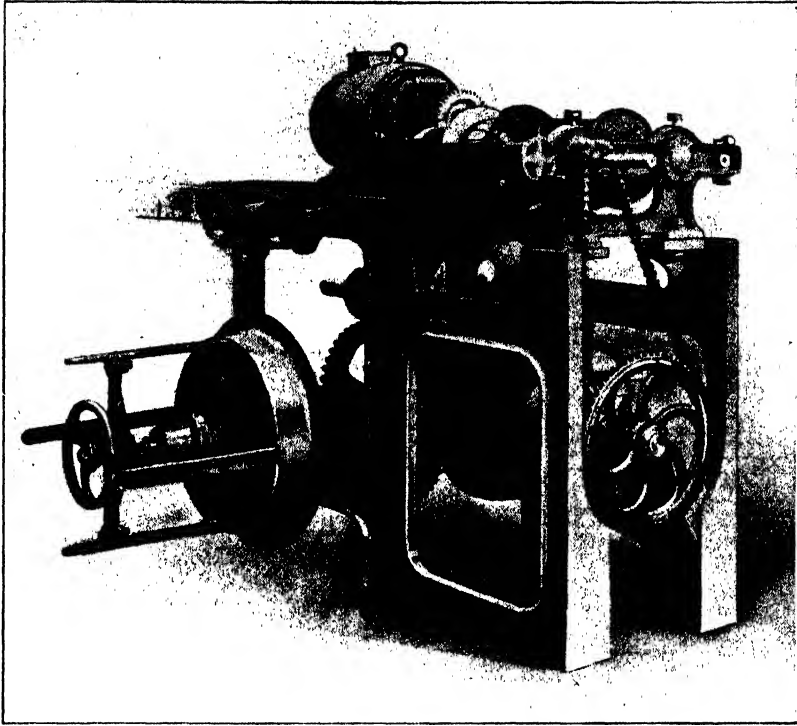

FIGS. 70 AND 71.—VARIABLE SPEED DRIVE FOR PATENTING FRAME.

BRITISH WIRE-DRAWING AND WIRE-WORKING MACHINERY

over triple guide pulleys directly above the winding drums, which straighten out any kinks and keep a slight tension on the wire.

The process of patenting naturally depends to a large extent on the speed at which the wire is drawn through the furnace, and it is consequently desirable that the speed of the drums should be adjustable. One method of effecting this adjustment is illustrated by Figs. 70 and 71, which show a Crossley frame. It should be pointed out, however, that this type of drive is not used at the Bradford Ironworks, as Messrs. Johnson prefer to install a variable speed motor. The electric motor mounted on the top of the frame drives the longitudinal shaft through a pair of expanding pulleys, like those fitted to the Lang lathe, and a chain and double-helical gearing. The expanding pulleys enable the speed to be adjusted, whilst the machine is running, with exactitude.

Galvanised wire represents an important proportion of the product of the works under review, and there is an equipment of 19 baths, the total output being about

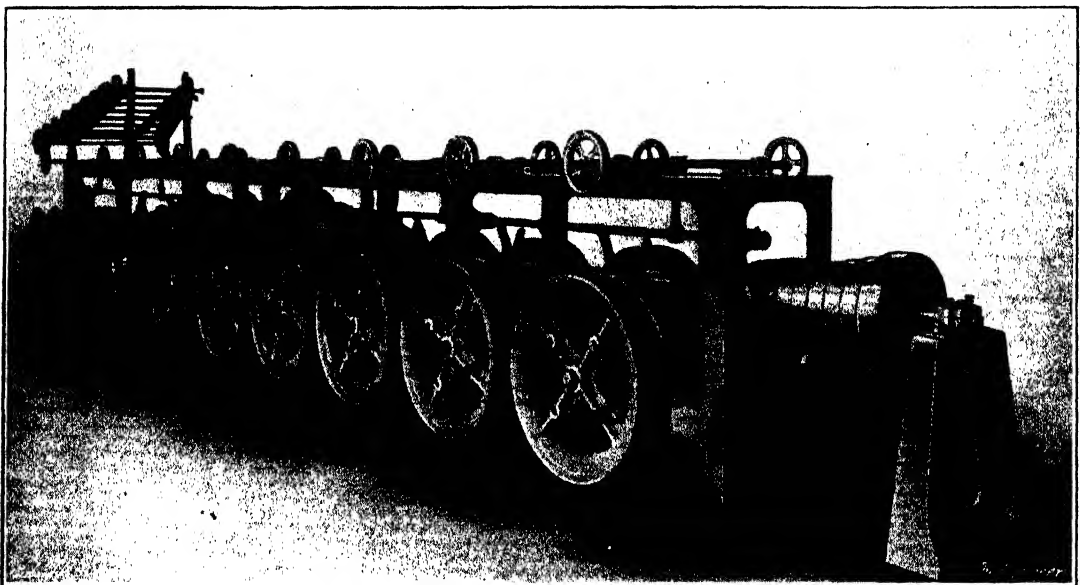

FIG. 72.—WIRE GALVANISING FRAME.

900 tons a week. It is noteworthy that this firm was the first to introduce the continuous process of galvanising, in 1860. Before that time galvanised iron wire was generally in bad repute, as it was often very brittle. This brittleness was to be accounted for by the practice then in vogue, of leaving the coils of wire standing on the swifts wet with weak acid from the cleaning bath. The surface also sometimes dried with a thin film of oxide, and would not then take the zinc properly.

In order to overcome these difficulties Mr. Bedson devised the continuous process, which has since been adopted universally. The wire is taken directly from the drawing machines, in its bright state, to the swifts of the galvanising plant, and is led through a long furnace in which it is annealed, or tempered if necessary. It then goes through a bath of hydrochloric acid, to remove the scale formed in annealing, and thence to the bath of molten zinc. The wires coming out of the zinc pass through a bed of sand, to wipe off any surplus metal, and are wound into coils on a long frame. Two of the galvanising baths, together with their acid tanks and frames, are shown in Fig. 65—their corresponding furnaces are out of view on the left—while Fig. 72 shows a galvanising frame.

WIRE FACTORIES

The wire is led over the guide pulleys shown, and is wound into coils on the deeply-grooved drums. These drums are split in two and held together by quick-opening clamps, so that the front half can be easily unshipped and a completed coil taken off with a minimum of delay and labour. The drums are provided with clutches for stopping them when they are being unloaded.

A large part of the galvanised wire made in the works is used in the manufacture of barbed fencing wire, and a view of the barb wire department is given in Fig. 67. A description of the machines themselves is given later.

The Bradford Ironworks also include a department for manufacturing copper, bronze and cadmium copper wire, commutator bars, bus-bars, strip, &c. It is equipped with a rolling mill, which hot-rolls the wire bars weighing 250 lb. each into wire rods $\frac{1}{4}$ in. in diameter, or of such larger sizes as the work in hand may require.

The drawing mills are very fully equipped with blocks and continuous machines for drawing the copper or alloy rods down to sizes ranging from as much as 1 in. square to as little as a diameter of $\frac{1}{100}$ in.

Two views of the copper drawing mill, which has a capacity of about 250 tons a week, are given in Figs. 68 and 69.

CHAPTER VIII

WIRE-NETTING MACHINERY

AMONG the heavier types of wire-working machinery, one of the most fascinating to watch at work is that used in the manufacture of ordinary wire netting, such as is used for poultry-houses, kennels, and fencing of all kinds.

There are only a few factories in this country where wire netting is made on any



FIG. 73.—HEAVY BLOCKS, ON LEFT, IN WIRE-DRAWING SHOP.

considerable scale, and the manufacturers naturally do not care to publish too many details of the processes and machines employed ; but the author was fortunate enough to secure the permission of Boulton and Paul, Limited, of Norwich, to inspect their entire plant, and the works manager, Mr. G. C. Clayton, explained the whole process. In view of the fact that a large proportion of the machinery installed was made in the firm's shops to designs by its engineers and not made for sale, he could not secure detail drawings. The rough sketches in this chapter will, however, help to elucidate the principles of the wire netting weaving machine, which is by far the most interesting unit involved in an extensive process. The sketches do not, of course, pretend to be to scale or accurate in detail, but they indicate the essential and peculiar features.

Before describing the weaving machine, however, it may be as well to give an outline of the preliminary stages through which the wire goes in the Norwich works.

Until comparatively recent times the firm was in the habit of procuring from out-

WIRE-NETTING MACHINERY

side sources the whole of the wire needed—some 250 tons per week. In view of the quantity required, a complete wire-drawing plant for producing a large proportion of the wire needed has, however, been put down. Figs. 73 and 74 are views in the wire-drawing shop. It is unnecessary to describe this plant in detail as it conforms to modern practice, but a noteworthy point is that a separate motor drive is employed for each wire-drawing block, except in the very smallest sizes.

The material for producing the wire is purchased in the form of rods of suitable diameter. Before drawing the rods into wire they are pickled in the usual manner—dipped in lime and thoroughly dried.

Instead of following the usual practice of purchasing pickling acid in carboys, which are always liable to breakage, the firm obtains its supplies in bulk, the acid arriving in railway tank wagons, from which it is discharged by compressed air into

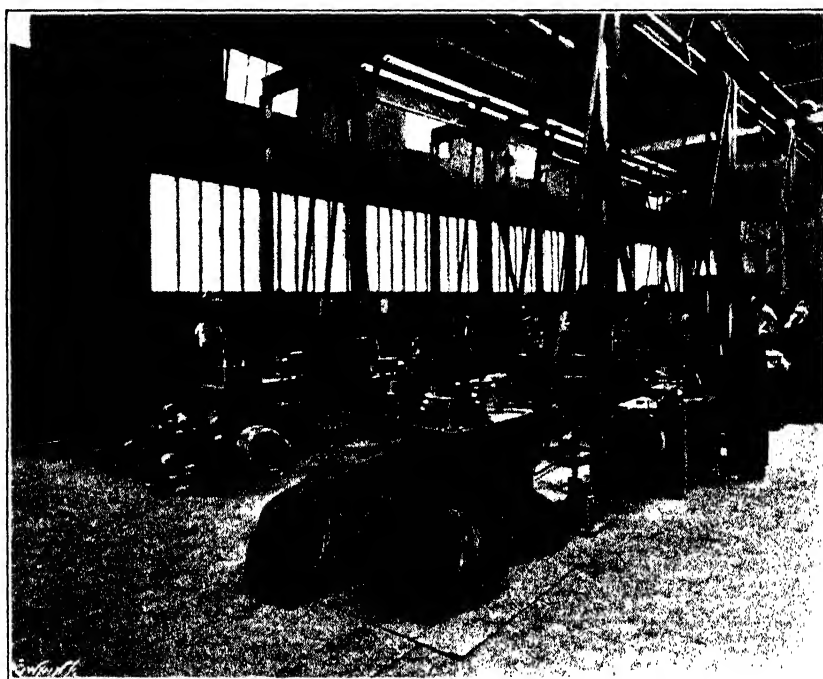

FIG. 74.—LIGHT WIRE-DRAWING BLOCKS.

a special rubber-lined overhead service tank. The acid is then fed by gravity to the various points required, thus eliminating waste, time in handling, and danger to the employees.

There are two types of powerful “breaking-down” machines in the wire-drawing department and a large number of smaller blocks for producing the various gauges of wire required, which is classed on the metric system, a variation from the nominal dimensions of not more than 0.03 mm. being permitted on the diameter of the wire. The coils of drawn wire are taken on electric trucks to a store at the end of the weaving and filling shops, and a large stock is kept on hand so that the production of finished netting is not held up through shortage of materials.

The first step in the actual process of making wire netting is carried out in the filling shop—Fig. 82, page 79—where half of the wire is wound into “springs” and the remainder is wound on to steel plate bobbins. The “springs” take their name, not

BRITISH WIRE-DRAWING AND WIRE-WORKING MACHINERY

from the fact that they are springy, but because they resemble a helical spring wound several layers thick. The springs are about 3 ft. long and vary in diameter and number of layers according to the gauge of the wire and the mesh size of the netting to be made.

The springs are produced on a machine having four horizontal spindles geared together and belt driven from an overhead line shaft. The spindles are slightly tapered, and the first layer of wire wound upon them is loosened by a simple device. This layer is then squeezed up longitudinally between two movable collars on the spindle; the remaining layers are then wound as required. When the spindles are filled the machine is stopped and the spring drawn off by hand. The machines run

at a high speed and are semi-automatic in action, the wire being fed to and fro by means of a screw so geared as to close-wind the wire and which reverses at predetermined points as the ends of the spindle are reached. A fair average size of spring carries about ten turns or layers, is $1\frac{3}{4}$ in. diameter, and weighs approximately 8 lb.

The bobbins, which are of sheet steel, are filled, six at a time, on a simple winding machine which has similar characteristics to the spring machine and needs no comment. Stocks of springs and bobbins suitable for all sizes of netting are held in store and are withdrawn as required by the weaving department.

The weaving machine is a most ingenious piece of apparatus, as has already been mentioned. It embodies a quite peculiar piece of mechanism, which, it is hoped, the following sketches will help to elucidate.

First, however, it may be best to scan the actual structure of the netting as a help to a proper understanding of the weaving mechanism. The point which it is necessary to emphasise here is that each mesh is produced by the twisting together of two adjacent wires.

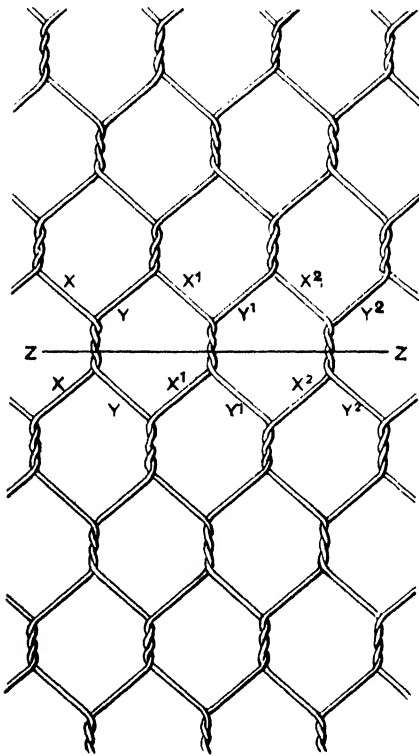

"THE ENGINEER"

SWAIN SC.

FIG. 75.

prepared from an ordinary piece of netting. X, X¹, X² represent wires coming from the springs, and Y, Y¹ and Y² wires fed from the bobbins. Assume that the machine has just twisted the wires together at the points along Z Z, the correct position for the next twisting operation is produced by causing the wires X, X¹ and X² to be moved one-half a mesh width to the left and the wires Y, Y¹ and Y² one-half a mesh width to the right. It will be seen that this movement brings wires X¹ and Y, X² and Y¹ together (X and Y² mating with their corresponding neighbours). The twisting movement is now performed and the reverse movement of the wires carried out, bringing them back to their original positions. The mean course of any wire, it will be noticed, runs straight through the whole length of the netting, the only deviations being those caused by the half-pitch movement described above. It may be noted in passing that the netting is made with either two or three turns (known as "twists") in the twisted portion, according to the gauge of wire and size of mesh adopted.

WIRE-NETTING MACHINERY

To proceed with the actual manufacture of the netting. The looms on which the work is done comprise a rigid framework carrying the driving mechanism, springs, bobbins, &c., and capable of producing netting up to 11 ft. in width and of any reasonable length. The general appearance of a loom can be gathered from the engraving, Fig. 83, page 80, while the arrangement of the essential and peculiar features is represented in the sketches.

Running across the width of the machine there are two pairs of bars of channel section (marked A in the sketch, Fig. 76), which are free to slide longitudinally in the main frame. The facing edges of the channel bars have a series of semi-circular holes—see Fig. 77—bored at intervals corresponding to the mesh width of the netting. When these channels are placed together it will be seen that the meeting of a pair of the semi-circular holes will form a round hole, which acts as a bearing for a pinion.

The arrangement of the pinions is best shown in the sketch, Fig. 80, from which it will be seen that each pinion is split across its diameter in the same plane as the joint made by the channel bars. The pinions are rotated by a long rack engaging with them all, the rack being reciprocated by a crank movement. The movements of upper and lower channel bars, with their respective racks, are synchronised. This sketch also indicates a hole drilled axially through each half pinion, for the passage of the wire, and the disposition of the spring tube or casing between the channel bars.

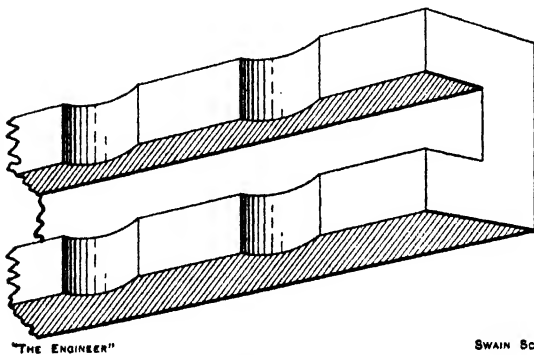

FIG. 77.

SWAIN Sc.

wire passed through the hole in the upper pinion, and the case secured by the spigots on the upper and lower pinions.

The wires are then led over a pegged roll at the top of the machine, which is driven at the proper speed to produce, in conjunction with the peg spacing, the correct mesh. Means are provided for maintaining an even tension on the various wires, so that the netting may be "dead flat." The twisted wires at the edges of the netting—known

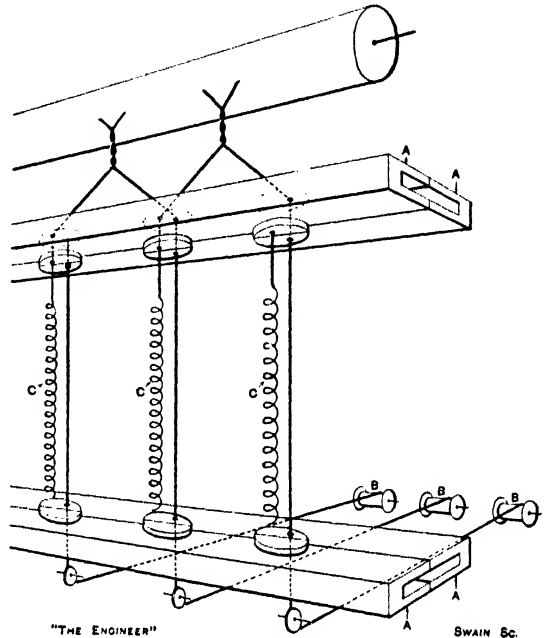

FIG. 76.

for the passage of the wire, and the disposition of the spring tube or casing between the channel bars.

Now, returning to Fig. 76, it will be seen how the machine is threaded up. Arranged on a frame at the back of the machine there are the ready-filled bobbins B B. The ends of the wires are taken over guides at the bottom of the frame and up through the holes in the front half pinions, which are represented on the right-hand side of Fig. 80. The springs are slipped into their tubular cases, the free end of the

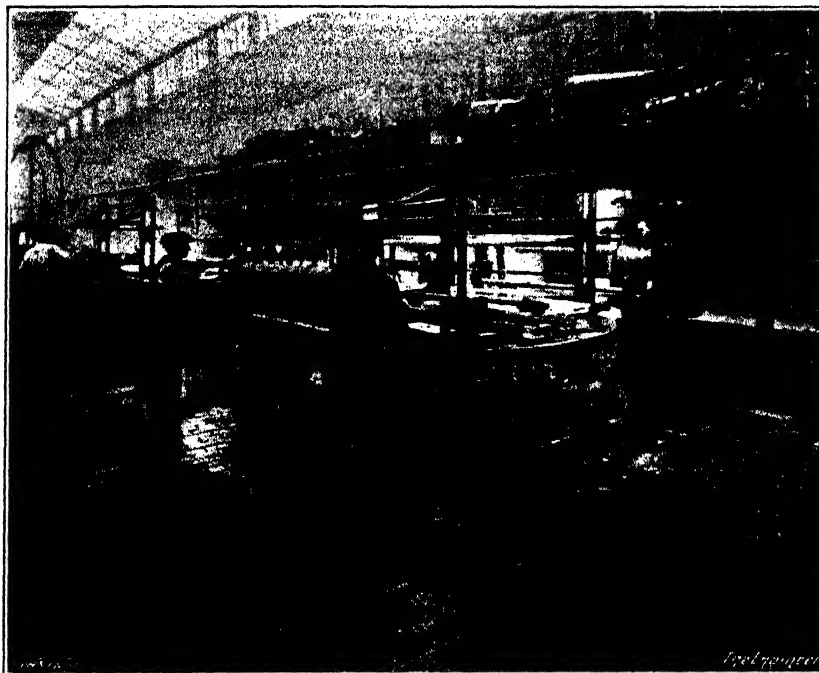

FIG. 78.—GALVANISING WIRE NETTING.

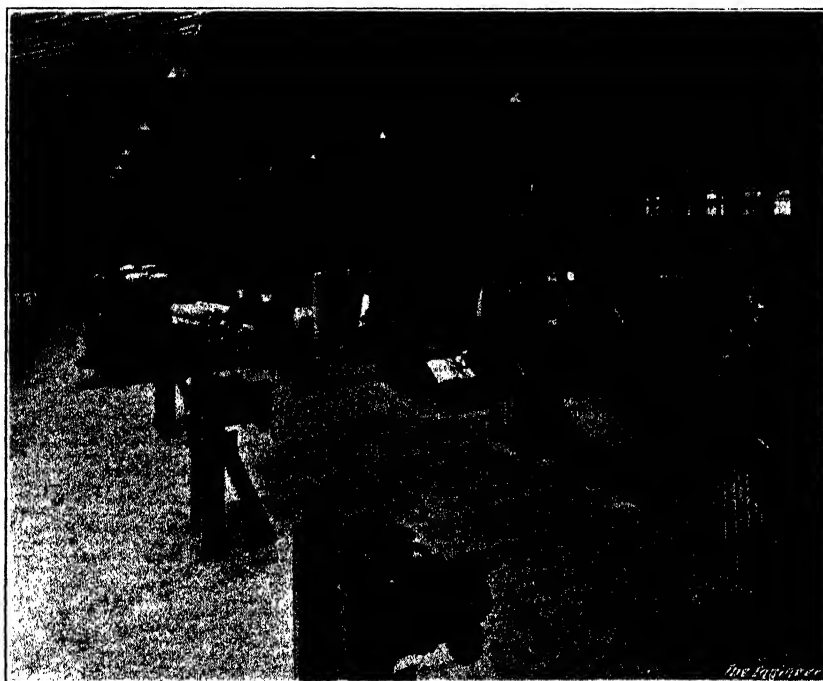

FIG. 79.—TIGHT-WINDING NETTING FOR EXPORT.

as the selvedge—are fed into the machine in a similar manner from bobbins, but are not accompanied by springs.

WIRE-NETTING MACHINERY

The action of the machine is as follows :—At a time when the joints between the half pinions lie in the same plane as the joint between the pairs of channel bars A A, the bars are moved endways in opposite directions, a distance equal to half the pitch of the pinions. As a result, the two halves of each pinion are separated, just as if they were sheared in two, and slide along against the plain face of the channel bars, until they come opposite the halves of the adjacent pairs. During this process the racks move together with the channels, so that the pinions are not rotated. As a matter of fact, they could not rotate since they have semi-circular journals in semi-circular bearings. The change in position of the half pinions is plainly shown in the diagram—Fig. 81—in which the top row represents the positions at starting, the second row those after one stroke, and so on.

When the half pinions have been mated with their new partners the racks are reciprocated, while the channel bars are held stationary, to such an extent that the pinions make two, or three, complete revolutions. The result is, of course, that the wire coming from each spring and that from the corresponding bobbin are twisted together directly above the pinion. The overhead pegged roller at the same time draws the netting forward at such a speed that the meshes formed engage with the pegs. The channel bars are returned to their original positions, so that the half pinions are re-mated with their original partners and the whole process is repeated.

It will now be seen why half the wire is wound as springs and half as bobbins, as if all the wires were on bobbins the strands would naturally become twisted together below the lower channel bars, making it impossible to feed the wire forward. It would, of course, be possible to work with two springs and no bobbins if there were room for their accommodation ; but the arrangement adopted allows the case for the spring to overlap the half pinion for the bobbin wire and consequently permits a much greater length of wire to be made up into the spring.

From the above description it will be readily appreciated that all the parts of the looms have to be made with a high degree of accuracy, especially the channel bars, racks, and pinions, the latter having to be truly interchangeable. At the same time

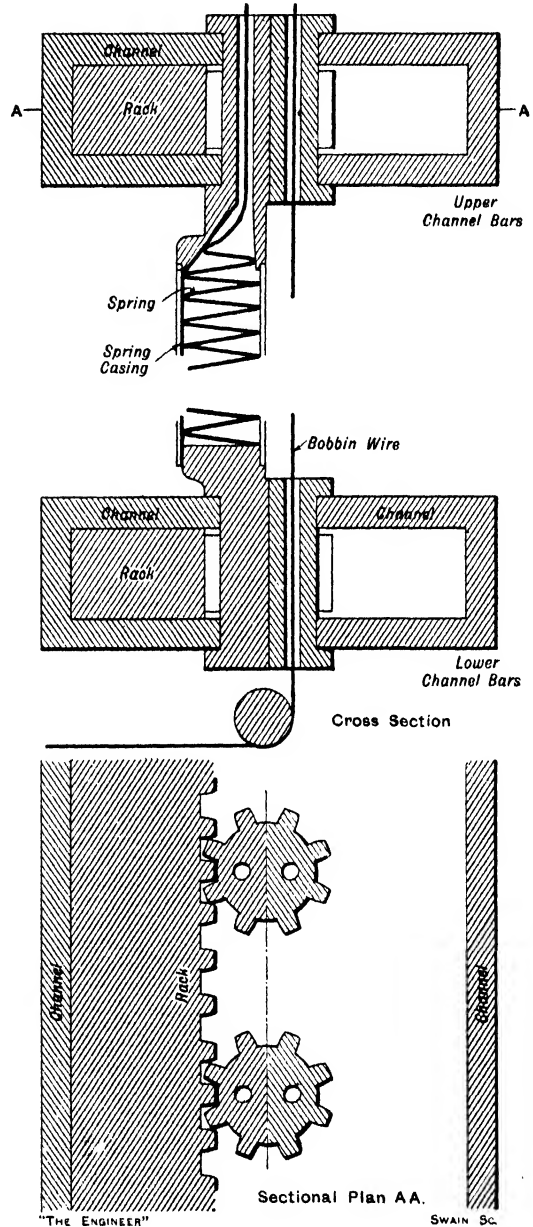

FIG. 80.

BRITISH WIRE-DRAWING AND WIRE-WORKING MACHINERY

the whole mechanism has to be very substantially constructed to withstand the heavy stresses imposed on it, as an average set of springs weighs about 500 lb., and, in addition to this, there is the combined weight of racks, channel bars, spring cases, and pinions, all of which has to be reciprocated at a rate of about 60 strokes per minute, while the strokes must be exact in length, or the half pinions will not register sufficiently accurately to rotate in their split bearings.

Some of the machines are set up for weaving netting with a mesh of only $\frac{3}{8}$ in., and in such cases the workmanship has to be of a very high order, as the dimensions of the several parts are so small.

A complete engineering staff is maintained for the purpose of keeping the whole plant in a state of maximum efficiency, and experiments are continually being made with a view to improving the construction and operation of the machines.

At the Boulton and Paul works the black netting—that is, netting direct from the looms—is taken from the weaving department and put into a large store, where stocks of all the various sizes are accumulated, and it is not until an order is actually received

that the netting is galvanised, thus ensuring that the customer receives it fresh from the galvanising bath.

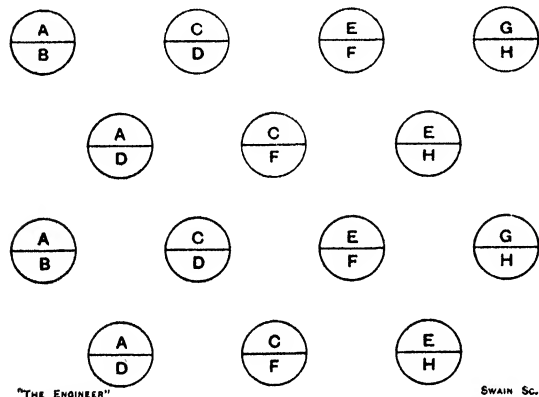

FIG. 81.

The rolls of netting are taken, as required, to the galvanising shop—Fig. 78—where they are dipped bodily into an acid pickling bath to clean them and remove all scale from the wire. The roll is then mounted on a spindle in a framing carried on the galvanising bath and is fed over rollers into the bath of molten zinc under two submerged rollers, and out at the opposite side of the bath where there is a floating layer of coke breeze, through

which the netting is drawn. This breeze serves to remove all surplus metal from the wire. The netting is then re-wound on a specially designed machine, and is ready for home order despatch. It should be pointed out that when the photograph of the galvanising shop was taken the hoods for carrying away the fumes from the baths had been removed, as they obscured the view. As a matter of fact this shop is notable on account of the clearness of its atmosphere.

In the case of export orders, however, the netting is again re-rolled, in order to make the rolls as compact as possible, and so save freight.

The machines for this re-rolling, known as tight winders, consist of three parallel rollers with a loose spindle at the centre of the group—see Fig. 79. The netting is attached to the centre spindle, and is wound under the pressure of the three rollers, which gradually recede from their common centre as their bearings move along scroll-shaped slots in rotatable end frames. The pressure on the rolls can be varied at the will of the operator by a form of friction gear. The result is a very solid roll, which saves a considerable amount of freight as compared with the roll as it comes from the galvanising bath.

The foregoing is really only a very cursory description of the general process of making wire netting, but before leaving the works of Boulton and Paul it may be worth while to mention a simple machine installed in the scrap yard. The machine in question is used to bundle the scrap wire from the various netting shops, and is made

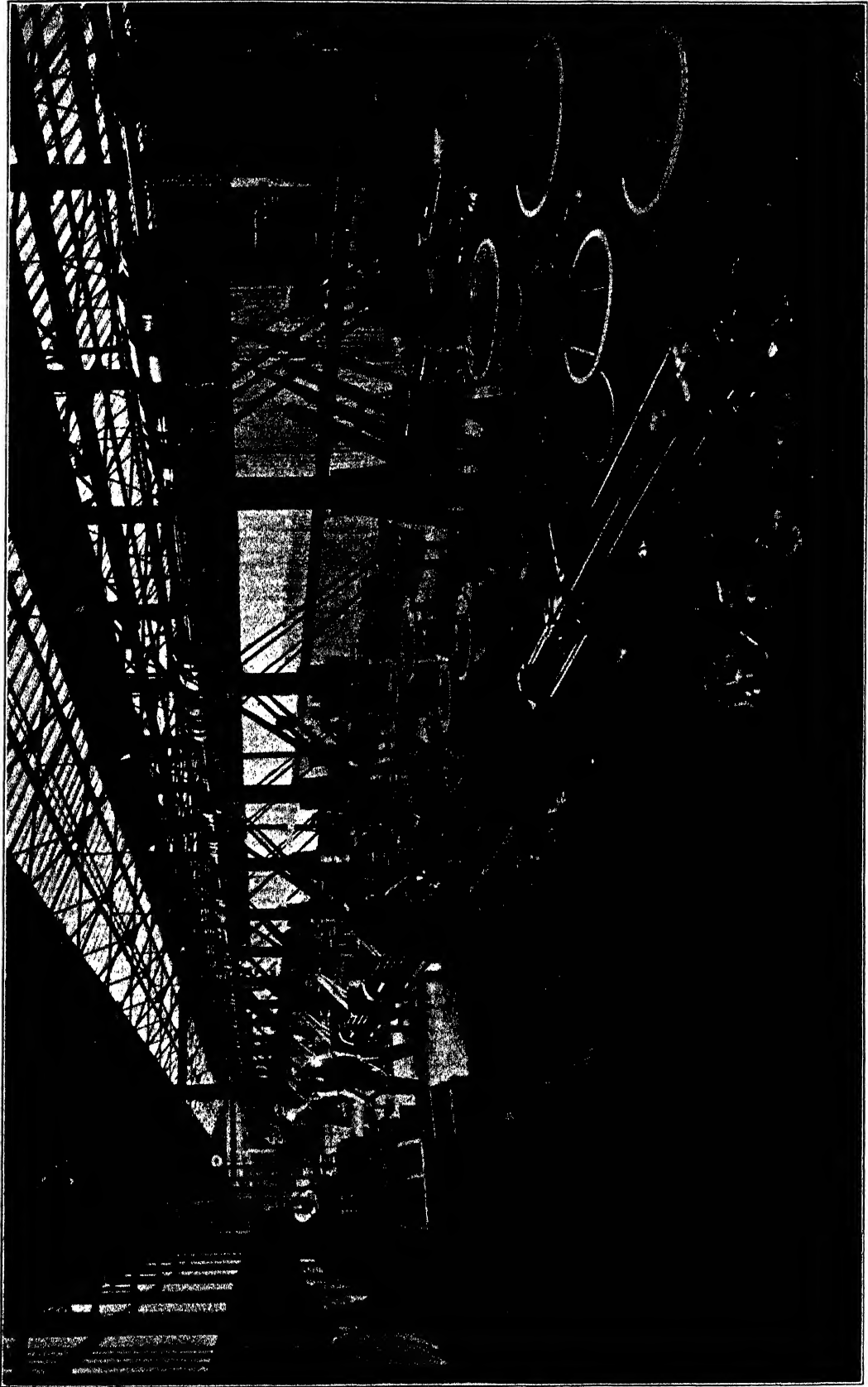

FIG. 82.—SPRING-WINDING SHOP.

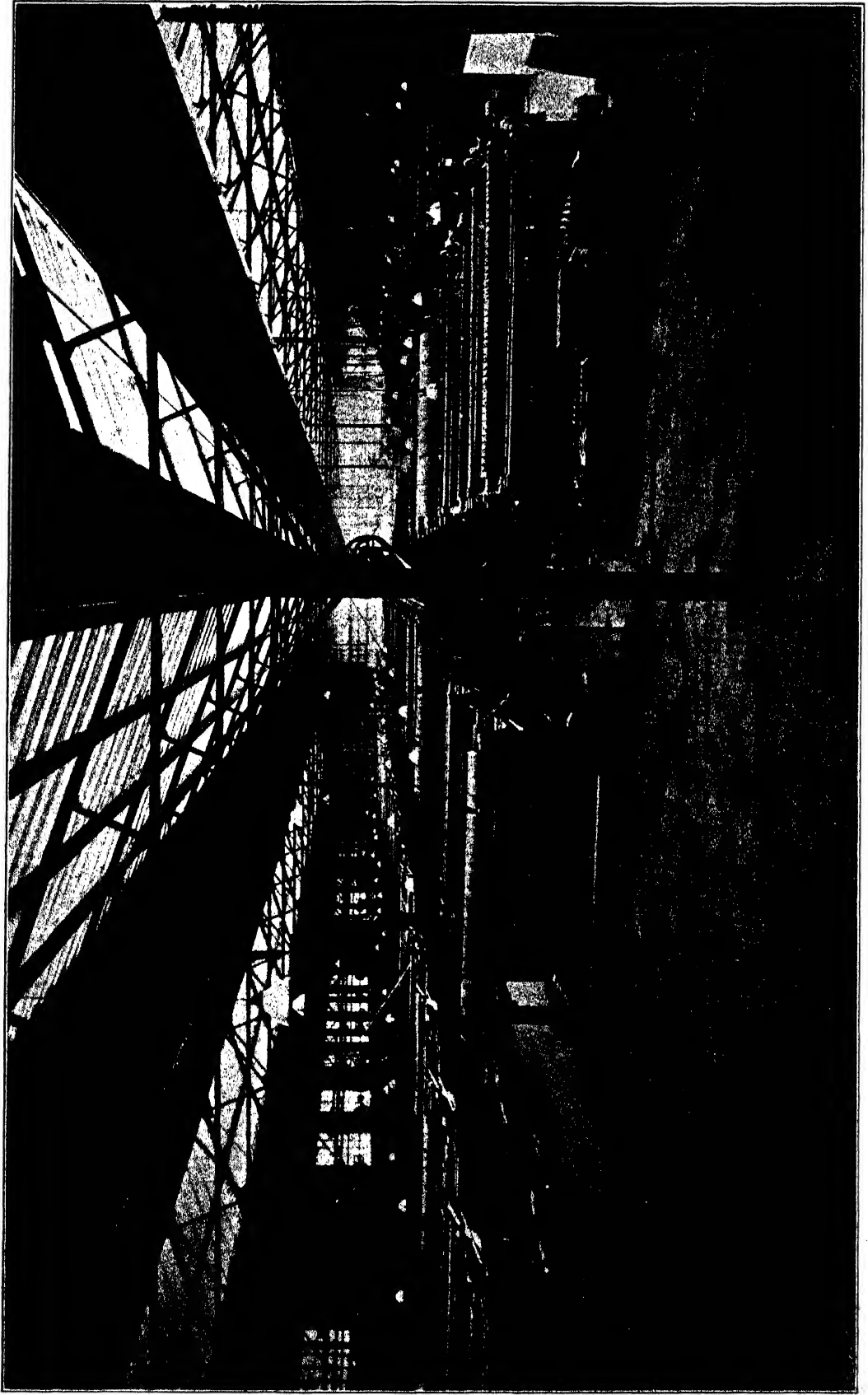

FIG. 83.—WIRE NETTING WEAVING SHOP.

WIRE-NETTING MACHINERY

by the Stonehouse Works Company, of West Bromwich. It comprises a horizontal spindle driven by belt through powerful gearing and running between two housings, like a rolling mill. Above the spindle is a heavy roll with its axle running in vertical slots in the housing, so that it can rise and fall. The scrap is shovelled on to a shoot in front of the machine, and the spindle started. When once the spindle has gripped the scrap, it drags it in, rolling it up with the spindle in the centre, the heavy roll above compressing the mass. When the machine is full, the bundle of scrap is wired round to prevent disintegration, the spindle withdrawn by a lever and ratchet, and the bundle rolls out from the machine. The bundle is about 21 in. long by 15 in. diameter, and weighs approximately $\frac{3}{4}$ cwt., while about 3 horse-power is required to drive the machine.

CHAPTER IX

WIRE FACTORIES

ONE of the largest factories in this country where steel wire is drawn and made up into finished products is that of Ryland Brothers, Limited, at Warrington, and the accompanying engravings give a good impression of the equipment there installed.

The total wire-drawing capacity of the works is some 1,500 tons a week, about a third of which goes into the manufacture of galvanised wire netting, nails, staples,

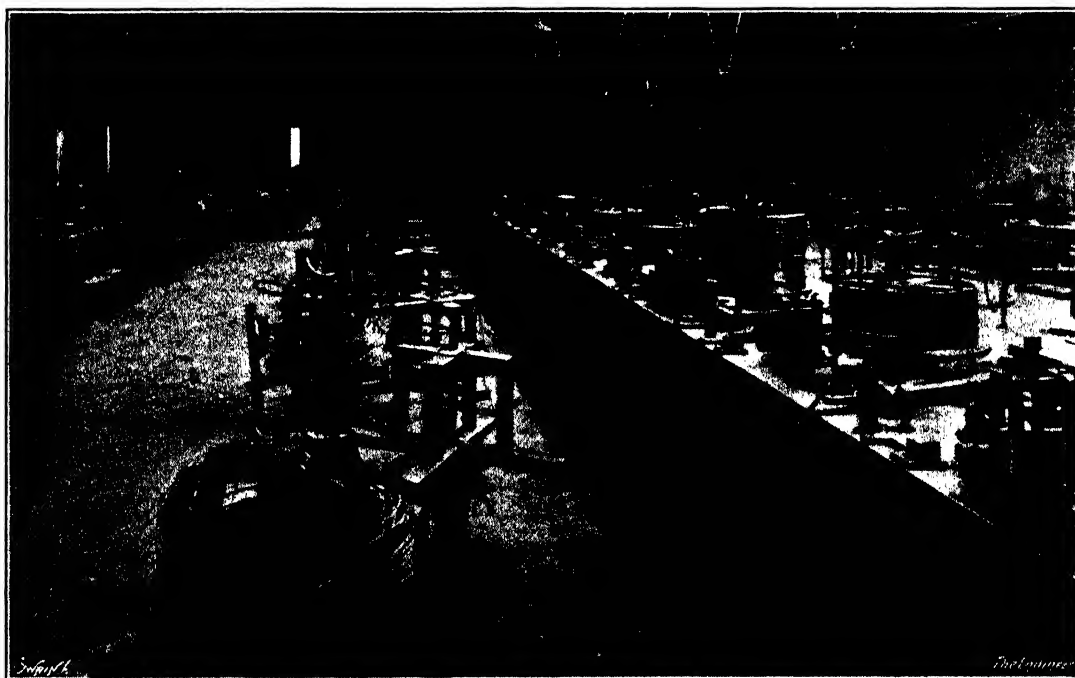

FIG. 84.—HEAVY WIRE-DRAWING MILL.

wire strand, &c., thus leaving a large surplus of plain, galvanised, tinned and coppered wire for sale in the home market and for export. The works are also noteworthy for being among the first in which the old-established practice of the Birmingham district of leaving the whole of the operations in the hands of the wire drawer was partially discarded. Many years ago additional departments which sectionalised the several processes, so that each man did not have to be highly skilled in many directions, were created in these works. Incidentally the firm was established so long ago as 1805.

Practically all the wire rods used in this establishment are purchased from the allied firm, the Pearson and Knowles Coal and Iron Co., Limited. They are pickled in the usual manner and are pointed in a special department equipped with rotary swaging machines before being sent to the wire-drawing department. The coils of rod are then sent through one or the other of several heated tunnels which provide com-

WIRE FACTORIES

munication between the cleaning and the drawing departments. The coils are loaded on to small trucks for their passage through the tunnel, during which they are thoroughly dried, and are pushed forward by hand. There are, of course, doors at either end of the tunnels.

On emerging from the drying tunnels the coils arrive in the drawing mill—shown in Fig. 84—where the heavier gauges of wire are produced. It is unnecessary here to describe in detail the construction of the wire-drawing blocks in this shop, as they are of the type employing the cam and lever system of drawing in described in Chapters IV. and V., and are, generally speaking, of the single-sided style. There are two light overhead runways, running the length of the shop, for carrying the coils of wire away through the doors seen at the end of the building. Beyond, there is a sort of

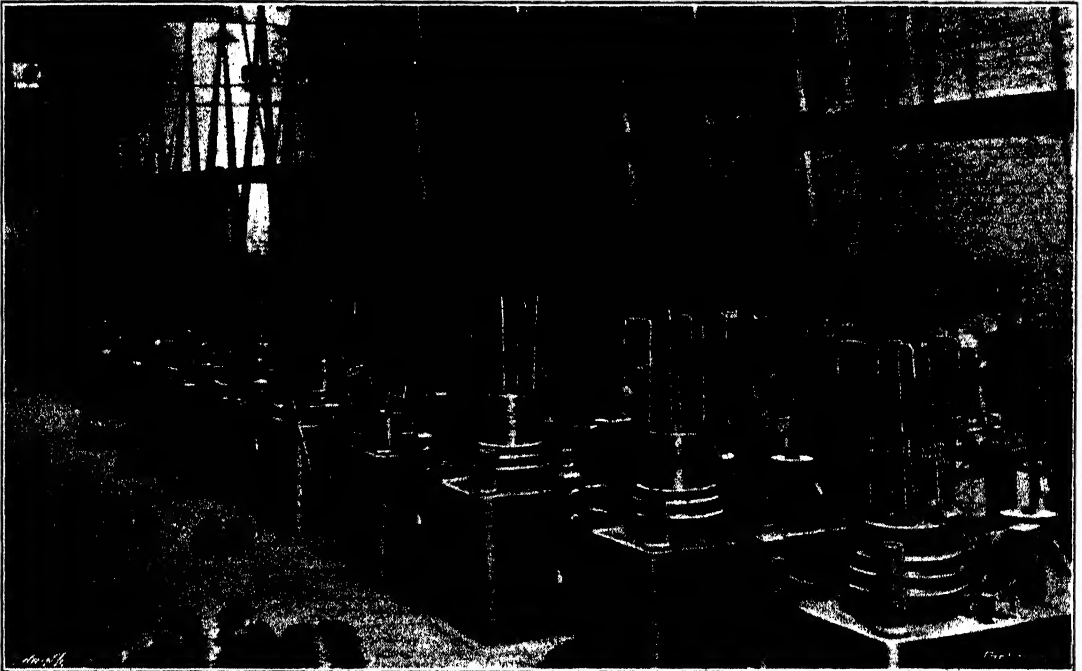

FIG. 85.—MILL FOR CONTINUOUS DRAWING THROUGH THREE HOLES.

hall in which the product of each man is separately accumulated during a shift and subsequently weighed, so that each man may be paid according to his output. It was very noticeable in this shop that the foreman was conspicuous by his absence. The men obviously needed very little supervision, and only required a very occasional visit from their overseer.

For drawing fine wire the wet and the dry processes are employed, according to the class of wire required. Fig. 85 shows part of the mill where fine wire is drawn in continuous machines by the three-holing process. It will be noticed that the blocks have graduated diameters to accommodate the extension of the wire as it is reduced in section. Fig. 86 shows the mill in which fine hard wire, such as that used for spring mattresses, is drawn. The machines are of the continuous type, with three holes, and the coils are immersed in tubs of liquor which contain, among other ingredients, some copper sulphate, so that they are given a fresh faint coating of copper. This coating, or lacquering, greatly facilitates the drawing of the hard wire, without annealing, and

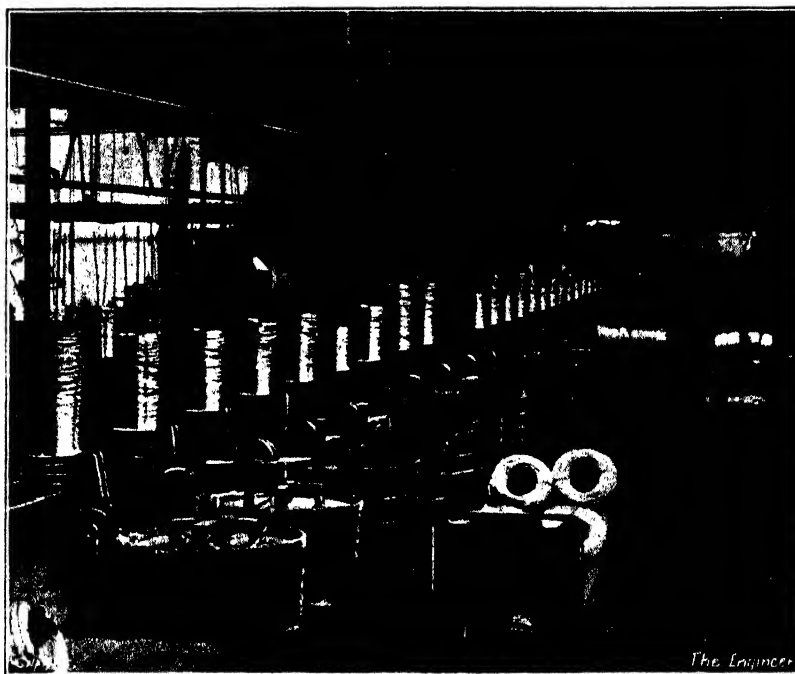

FIG. 86.—WET MILL FOR CONTINUOUS DRAWING OF FINE WIRE.

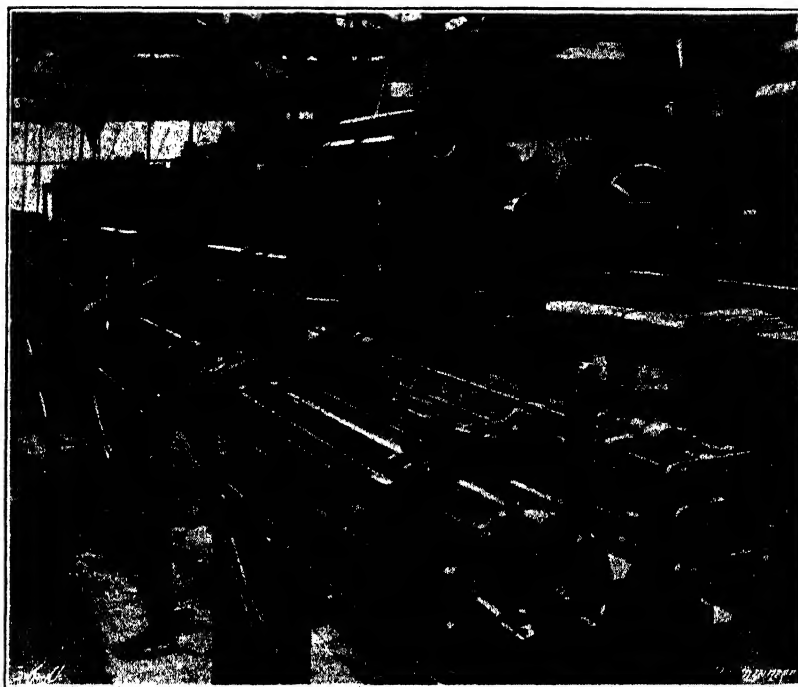

FIG. 87.—MAKING SPRINGS FOR WIRE NETTING.

merely leaves a brownish tint on the finished wire. The copper is so thin that its presence is hardly detectable by the uninitiated—so thin, in fact, that it has no

WIRE FACTORIES

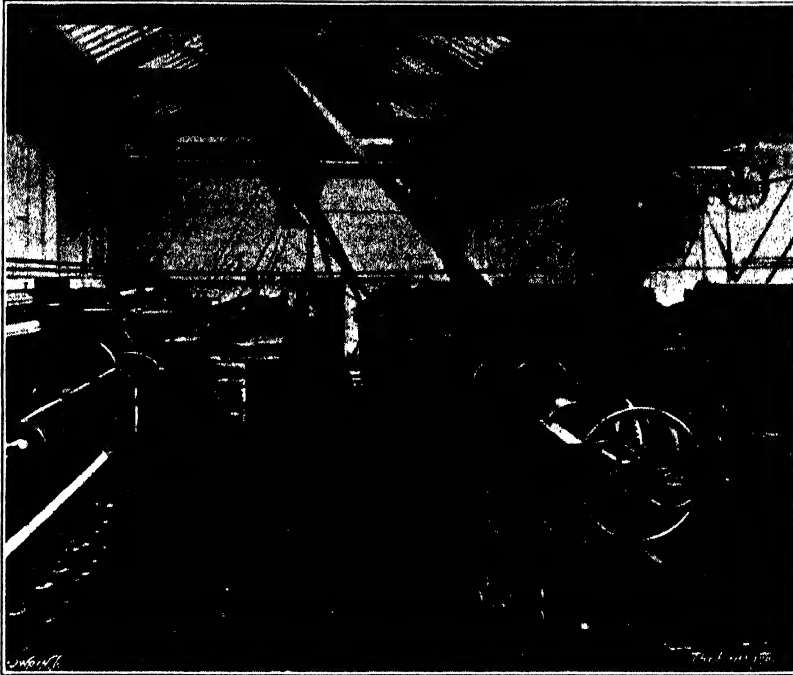

FIG. 88.—SMALL WIRE NETTING LOOMS.

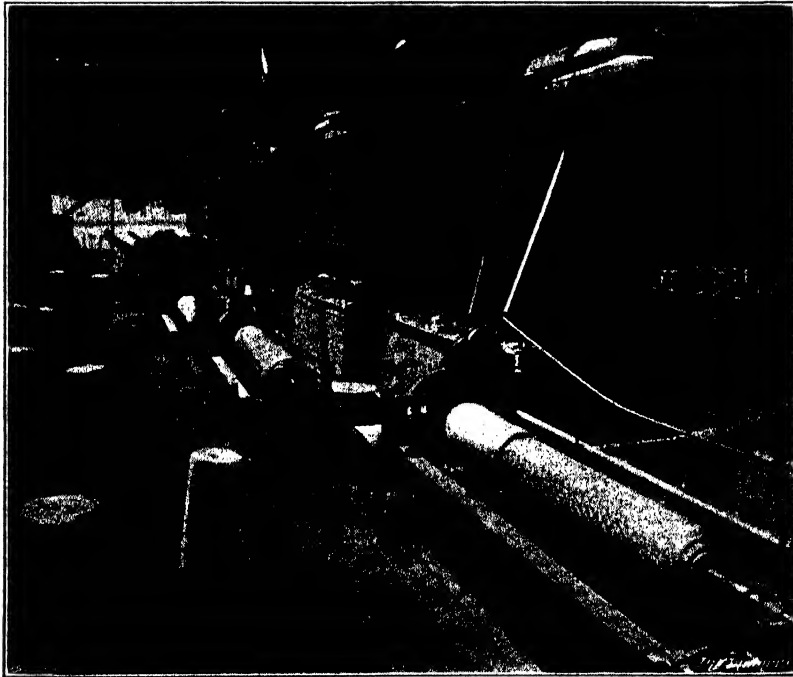

FIG. 89.—GALVANISING WIRE NETTING.

material value as a protection against corrosion, but it is, nevertheless, an important factor in the successful drawing of this class of wire, and assists the subsequent tinning

BRITISH WIRE-DRAWING AND WIRE-WORKING MACHINERY

process to which it is subjected for the purpose of producing the finest tinned mattress wire.

In the case of the wire used in the manufacture of upholstery springs the copper coating is made much thicker, as it is required to provide a protection against rusting, and incidentally to present an attractive appearance. The wire is, however, of a much heavier gauge than that used for mattresses.

The illustration—Fig. 86—also gives a very good impression of the overhead runway system, that extends throughout the wire-drawing departments, and which is supplemented by rail trucks for heavier loads.

The foregoing notes are only intended to give a rough outline of some of the more interesting parts of the wire-drawing departments, and do not profess to cover the



FIG. 90.—BARBED WIRE SHOP.

whole establishment, as much of the descriptive matter would be merely a repetition of what has already been said.

Among the making-up departments at Warrington, one of the most extensive is that devoted to the production of wire netting, which is made in all sizes of mesh, $\frac{1}{2}$ in. to 4 in. and up to 9 ft. wide. Figs. 87 and 88 illustrate two sections of the weaving sheds.

The machines in these shops are similar in general principle to those already described, but there are some peculiarities which mark them out as distinct.

The machines used for making the springs for loading into the looms are well illustrated in Fig. 87, from which it will be seen that the four horizontal spindles of each machine are arranged above one another. The arrangement provides a very convenient lead for the wires coming from the traversing guide, seen in the foreground. A bundle of finished springs is shown on the horse just behind the machine, while in the background there are several of the larger netting looms.

The characteristic feature of the looms is the arrangement for drawing forward the

WIRE FACTORIES

netting as it is made; otherwise they are very similar to the machines already described. Instead of using a pegged roller for this purpose, Messrs. Rylands employ a group of three plain rolls, round each of which the netting is passed in succession. The rolling effect on the netting makes it exceptionally flat and straight, while there is no necessity for the attendant to watch for the possibility of the wires catching on the tops of the pegs.

Fig. 88 illustrates some of the smaller netting looms and gives a very good idea of the driving mechanism for reciprocating the pinion racks. The drive is transmitted through bevel wheels to a transverse shaft, with an overhung disc crank. The crank pin works in a slotted crosshead, the upper end of which can be seen on the extreme right of the driving frame. The upper and lower pinion racks are connected with the



FIG. 91.—WIRE ROPE DEPARTMENT.

opposite ends of the crosshead, but a small amount of backlash is allowed in the connection. The extent of this backlash can be adjusted by means of set screws. There is a similar adjustment in the drive for the channel bars, and by regulating the two the slight pause necessary to allow the pinions to turn can be timed correctly.

A small matter in connection with the weaving of netting, which has not previously been referred to, may be appropriately introduced here. It is, of course, impracticable to make up springs containing a sufficient length of wire to produce a roll of netting, and it consequently becomes necessary to join the wires together as the springs are exhausted.

When the end of a spring wire comes to the top pinion the attendant stops the machine and turns the spring case round so that a window at its top is accessible. He then slips a new spring into the case, through the window, and pulls out the front end of the wire, which he threads through the proper half pinion. As soon as the machine is started up again the tail end of the last wire and the beginning of the next



FIG. 92.—NAIL-MAKING SHOP.

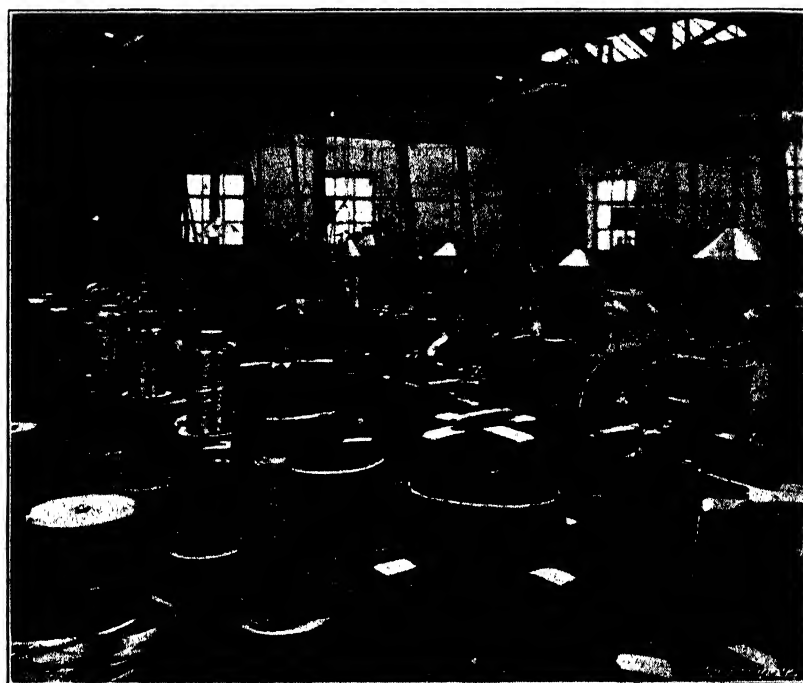

FIG. 93.—WIRE-FLATTENING DEPARTMENT.

spring are wound together round the other wire of the mesh, and the subsequent galvanising thoroughly joins together the two lengths. It is consequently possible

WIRE FACTORIES

to make a length of netting which is only limited by the rolling capacity of the machine.

After having been dipped in acid to remove scale and dirt the netting is passed through a galvanising bath—as shown in Fig. 89. It will be noticed that the spelter pots are well hooded, and it is the boast of Messrs. Rylands that their galvanising shop is one of the freest from fumes of any in the country.

The netting emerging from the bath is drawn off on to a roll which is driven through the speed cones seen in the upper part of Fig. 89. The position of the belt on these cones is so adjusted that the tension on the netting remains constant, regardless of the amount which has been coiled up, and a good hard roll is obtained. It might be interesting to record that, to handle the large volume of wire and netting during the process of manufacture, this department is well equipped with electric battery trucks.

The remaining illustrations of the Ryland works represent the barbed wire, wire rope, flattened wire and nail departments, and are chiefly interesting here as examples of general arrangement, as the individual machines involved are dealt with later.

The nail shop is specially noteworthy, as it was equipped during the war, and at the special request of the Government, for making nails which previously had been imported. The machines are of the American pressure type, but some were made in England, and the organisation has been so perfected that wire nails are produced at a price comparable with that of the nails made under the more favourable conditions in vogue on the Continent. The plant is capable of producing round and oval wire nails, while there are some machines for spiral grooving wire for screw nails, and a battery of staple-making machines.

A noteworthy feature in the wire-rope making departments—see Fig. 91—is the arrangement of the machines in such a manner as to facilitate the delivery and collection of materials. The draw-off and reeling mechanism is at the same end of the machine as the feed, the rope being led round a sheave at the opposite end, so that the machine is doubled back on itself. The arrangement economises space, and also brings the feeding and take-off stations alongside one gangway.

CHAPTER X

WIRE-WEAVING LOOMS

THE looms generally employed in the production of wire cloth, or gauze, closely resemble, in general principles, those used in the textile industries, but they possess, nevertheless, many distinctive characteristics, and these peculiarities are largely accounted for by the untractableness of wire as compared with fibrous yarns. Wire will not, for instance, yield so much as cotton or wool, and will break off short if overstressed, with the result that the cloth made is defaced by broken ends. Again, the specifications to which wire cloth is manufactured are often very stringent, and a single

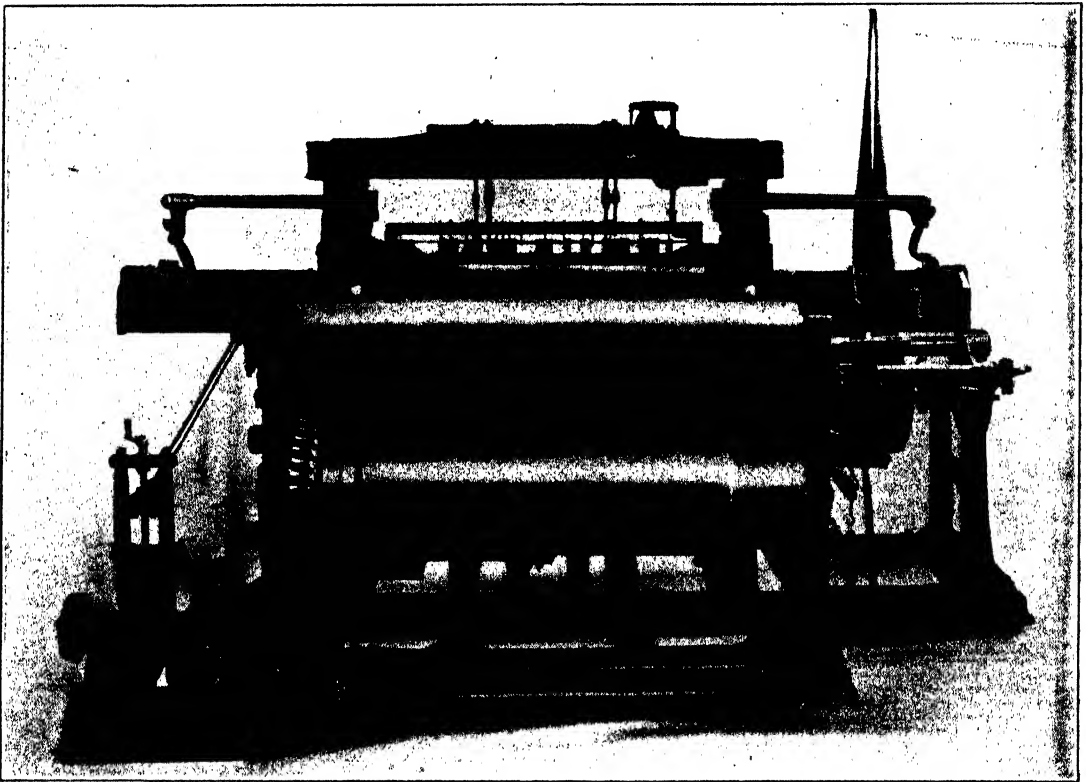

FIG. 94.—FLYING-SHUTTLE WIRE-WEAVING LOOM—ANDERSTON.

defect in a large area may result in the rejection of an otherwise valuable piece of material. Consequently all the working parts of a wire loom have to be made with the highest degree of accuracy. Wire, also, is not so flexible as yarn, and the machines have to be run at a correspondingly reduced speed.

There is in this country quite a large number of firms engaged in the manufacture of wire cloth, and among them one of the largest is Richard Johnson, Clapham and Morris, Limited, of Newton Heath, Manchester. The works of this firm are also

WIRE-WEAVING LOOMS

incidentally specially noteworthy through employing most of the principal types of wire loom, two of which are illustrated by the engravings Figs. 94 and 95. The first of these two classes is made by the Anderston Foundry Company, of Glasgow, while the second was manufactured by Walter McGee and Sons, of Paisley.

The new weaving sheds of Messrs. Johnson are illustrated by the engravings on

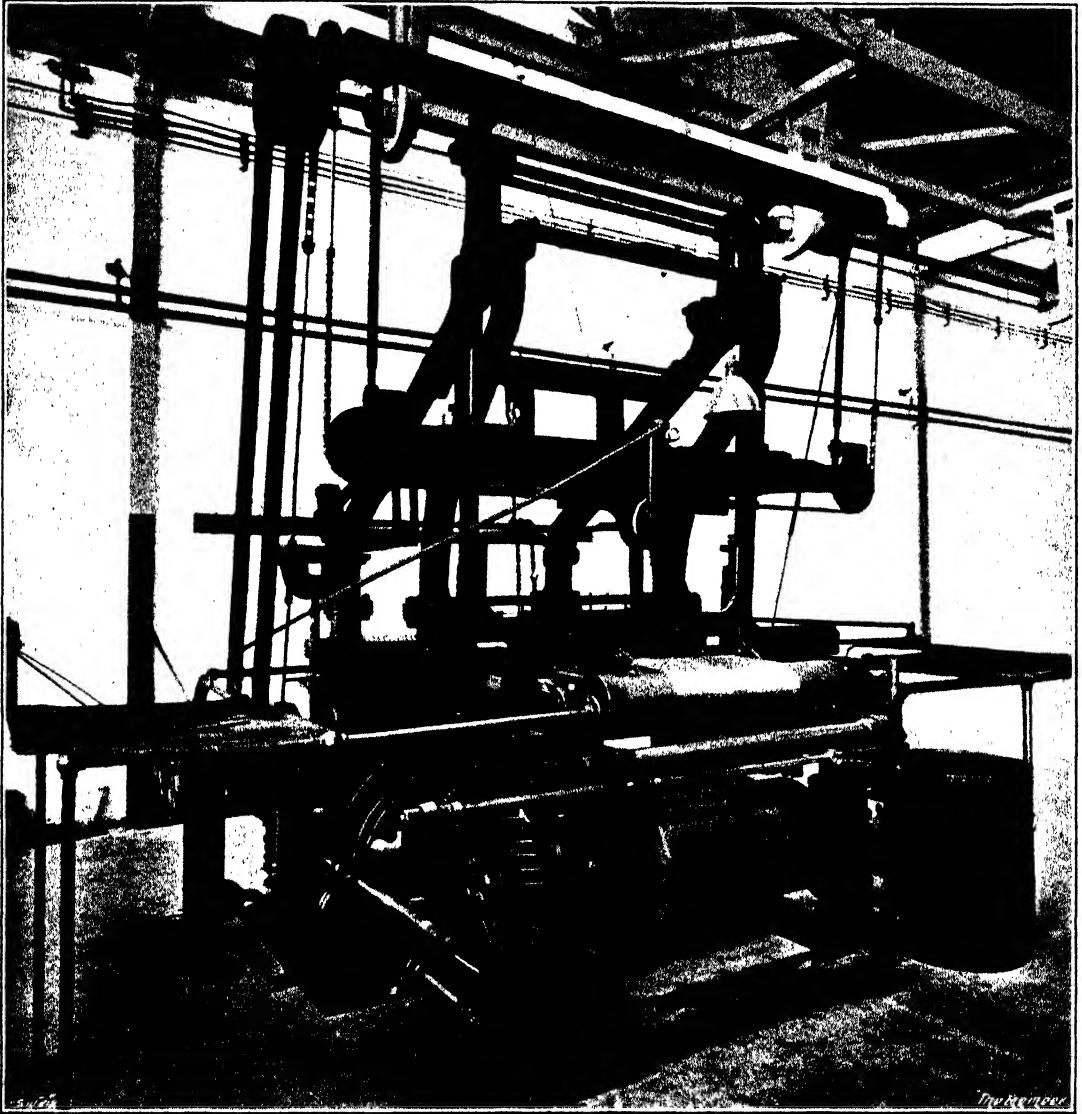

FIG. 95.—POSITIVE-ACTION WIRE-WEAVING LOOM—MCGEE.

pages 99 and 101, and there is also an extensive separate department for the drawing of the wire consumed by the looms ; but the procedure in the wire-drawing shops follows so closely the practice already described, that it is unnecessary to enlarge upon that part of the works. The output of wire cloth covers a very wide range both as regards the actual size of the pieces and the weight of the mesh, while a speciality has been made for a number of years in heavy rolled woven wire cloth in both copper and steel.

BRITISH WIRE-DRAWING AND WIRE-WORKING MACHINERY

The stresses imposed upon the machine in weaving wire must obviously be much greater than they are with textile cloths, and the operation of "beating up" is one of the principal factors in determining the design of wire looms. "Beating up" is, of course, the action of forcing, by means of a "reed" and "lay batten"—described later—the weft or transverse wire up into the angle formed when the warp or longitudinal wires are separated for its reception, and it will be readily appreciated that in order to produce a fine mesh it is necessary to beat up hard, as the warp wires have to be bent back and forth round each of the wefts. Another difficulty is caused by the stiffness of the weft wire, which checks its unwinding as the shuttle goes from side to side of the cloth. Such considerations as these, together with the width of the material woven, determine the speed at which a loom can be worked, and the output ranges from about 120 picks a minute downwards, according to the gauge of the wire being used. A pick is, of course, the passage across the machine of a weft wire. In other words, a lineal inch of cloth of 120 mesh would be produced per minute when the machine was working at 120 picks per minute.

The mesh of the wire cloth produced is mainly governed by the structural strength of the loom and the gauge of the wire being used, which must be such as to allow of the necessary beating up to give the required mesh. Speaking generally, the heaviest make of cloth which can be woven from any given size of wire is one giving a screening area or opening of 25 per cent. That is to say, a cloth in which the meshes are arranged to leave square apertures equal in size to the diameter of the wire being woven. It is, however, possible to make a cloth even more dense than this by passing it through rolls, after it is woven, and thus squeezing out the wires to fill, more or less, the apertures.

Broadly speaking, wire cloths fall into three principal groups:—(1) Such as can be woven at a high speed, which limits the size of the wire to a maximum of about No. 25 S.W.G. ; (2) cloths woven from heavier wires, which can be woven automatically, but at slower speeds, from wires with a maximum of No. 15 S.W.G. ; (3) wire cloths and fabrics made from wires too stiff to be shuttled automatically, which involve the use of a semi-automatic machine, assisted by hand-work. The consequence is that in any factory which sets out to manufacture the whole range of cloths, a variety of machines is required, and in the following notes an attempt is made to explain the leading features of the several types.

Taking first the loom illustrated by Fig. 94, by the Anderston Foundry Company, which perhaps follows more closely the practice of the textile industries than does any other one, the first characteristic which strikes one is the great care which is bestowed on the machining of the "warp beam"—the roll which is used to accommodate the supply of wire for the longitudinal part of the mesh to be woven.

It is obvious that the elasticity of the wires cannot be depended upon for taking up any inequalities in the rate at which the wire is supplied by the warp beam, and, as a consequence, the warp wires have to be wound on to the beam in a meticulously even fashion. The warp beams are sometimes wound, or filled with new wire, in the looms themselves, but otherwise they are taken away to separate frames for winding. In either case the wire is fed into a series of deep grooves in the warp beam. Each of these grooves must contain an equal quantity of wire, or there may arise a difference in the tension of the individual wires at some time or another during the process of weaving a length of cloth. For this reason the warp beam is turned out of a solid cylinder of cast iron, and the grooves are machined with a very high degree of accuracy. The grooves are generally spaced at 1 in. centres, and consequently if, for instance, a cloth of 12 mesh is to be woven, each of the grooves will have to accommodate twelve

WIRE-WEAVING LOOMS

parallel wires. The result is that not only must the warp wires be wound very carefully, but they must be matched one with the other.

Wire for weaving must be specially well annealed, and the annealing, as affecting the relative hardness or softness, sometimes varies perceptibly in different parts of a coil. During weaving the wires stretch, more or less, and as hard wires will stretch less than softer wires, the effect of a few hard wires in a web will show throughout the whole length of cloth woven, and in closely woven cloths such hard wires may give so much trouble as to necessitate their being cut away from the warp beam.

For closely woven cloths it is also very necessary to check the wire for diameter,

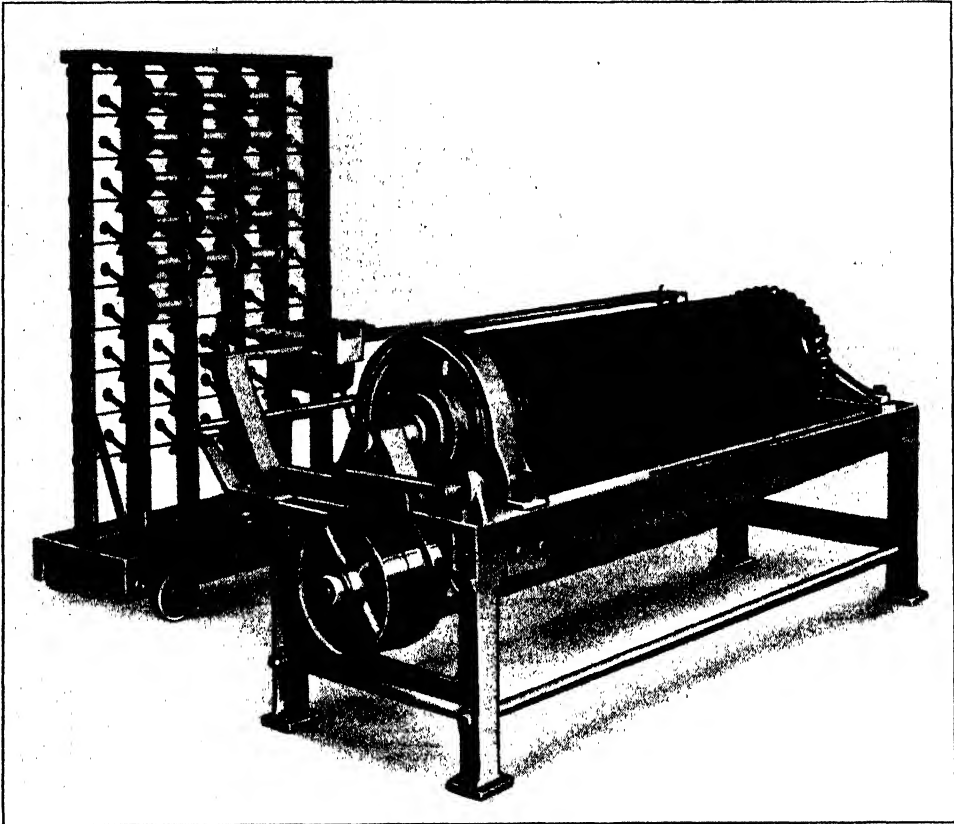

FIG. 96.—WARP-BEAM WINDER AND BOBBIN CREEL—ANDERSTON.

and it is not sufficient to accept a coil as being of the same gauge at both ends. If, for instance, a cloth of 25 per cent. screening area were being made, and the wire, starting at No. 25 gauge (0.02 in. diameter), finished the coil at No. 24½ gauge (0.0216 in. diameter), the cloth could not be woven towards the end of the run.

For this, and various other reasons, the warp wires are not wound directly on to the warp beam from the wire-drawer's coils; but are first wound on to bobbins and examined during the process. The bobbins are then put in a creel, as shown in Fig. 96, and taken to the separate beam winder, or to the loom, depending upon which system of winding is adopted. There is a little brake bearing on the flange of each bobbin to keep a slight tension on the wire as it is unwound.

The wires are led from the bobbins through what is known as a "marshall box," which can be seen fixed on a slide bar at the back of the winder in Fig. 96. The

BRITISH WIRE-DRAWING AND WIRE-WORKING MACHINERY

marshall box is fitted with five or six oval "lease rods" of hard wood—see Fig. 97—under and over which the wires are passed to produce an even tension. It is necessary that the wires coming from bobbins above the level of the box should start by passing

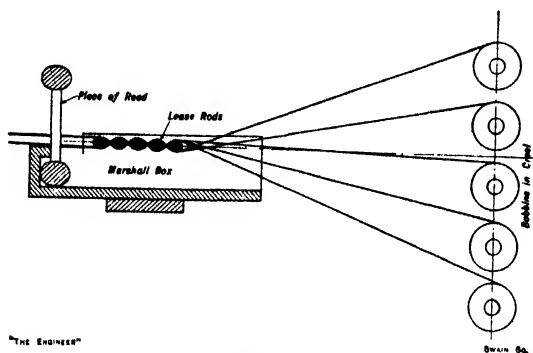

FIG. 97.

under the first lease rod, and *vice versa*, or the proper effect will not be obtained. After leaving the lease rods the wires are threaded through a short length of reed, which separates and keeps an even spacing between them. Finally, the attendant keeps a light touch, with his finger and thumb, on the ribbon of wires to guide them into the groove in the warp beam, to which each bunch of wires is first attached by looping it round a nail driven into a wooden peg sunk in the bottom of the groove.

If, in the process of winding, a loose or broken end of wire should appear, the attendant carefully twists the two ends together, and marks the place with a little piece of gummed paper. The paper subsequently attracts the attention of the weaver, who undoes the joint, so that the wire may go through the machine, and makes the joint again in the cloth. In weaving steel wire, the warp is generally first oiled, but no lubricant must be used with brass or copper.

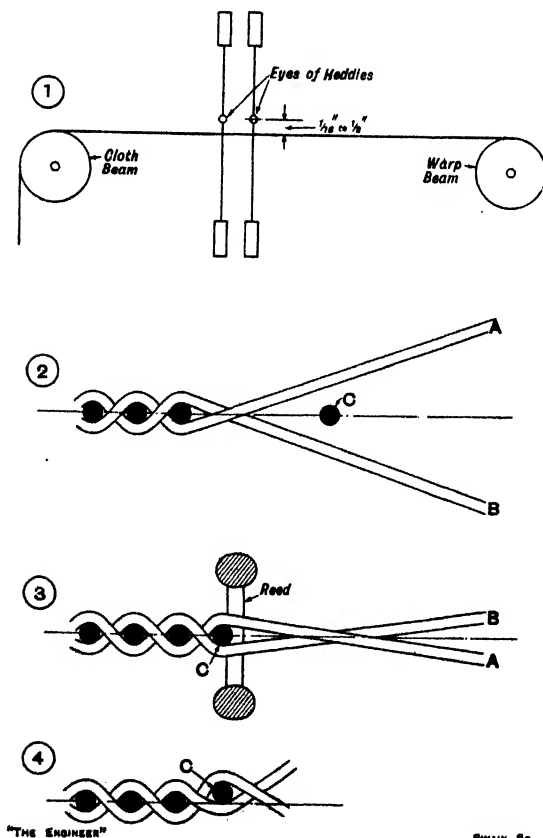

FIG. 98.

levers operated by a two-leaved cam fixed on the bottom shaft of the loom, which is known as the picking shaft. In this way the warp is separated into layers, or sheds, between which the weft wire is shot by the shuttle.

The adjustment of the shed opening in a wire loom is a very important matter, as

WIRE-WEAVING LOOMS

wire cloth is very liable to show imperfections through bad adjustment in this direction. The heddles must, of course, be so set that the eyes are all in line and parallel with the face of the cloth, while the stroke of the two frames must be equal. It is usual also to adjust the warp and cloth beams to such a height that a line joining their tops is just below—say, by $\frac{1}{6}$ in. to $\frac{1}{8}$ in.—the eyes of the heddles at mid-stroke, as shown in the upper sketch of Fig. 98. This setting is adopted for the following reason:—

If, at the time when the lay batten is back, the sheds are open and the shuttle leaves a weft wire C—see 2, Fig. 98—in the shed, the distances of A and B from the line between the beams are equal, the tensions in the two sets of weft wires must be equal. The next sketch—3—shows the reed on the point of beating up the weft after the sheds have crossed. If, however, there happen to be one or two slack warp wires, there will be a tendency for the weft to rise or fall as these wires yield—as indicated

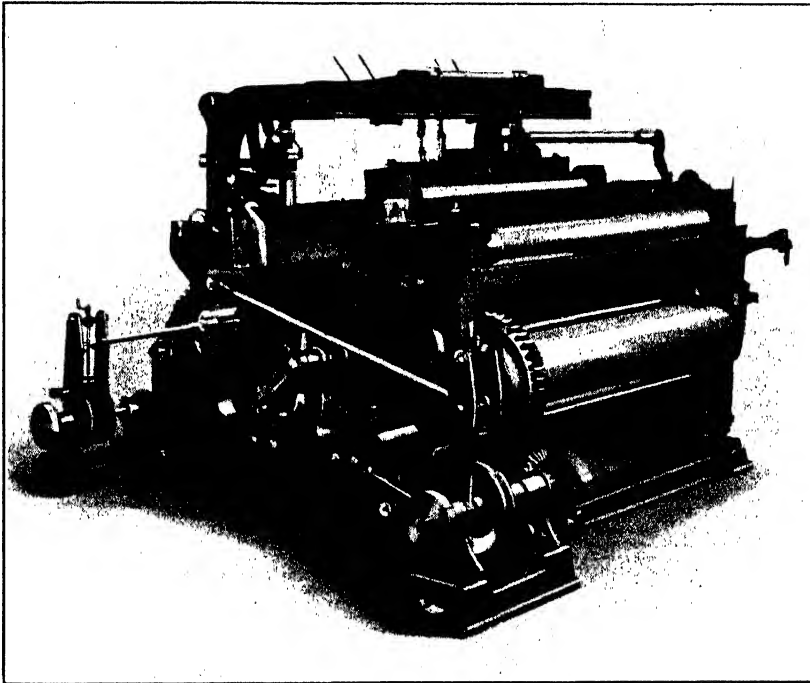

FIG. 99.—HIGH-SPEED OVER-PICK LOOM—ANDERSTON.

in sketch 4—and the indiscriminate deflection of the weft will result in unsightly patches in the cloth woven. By adopting the high setting of the heddles just mentioned, the lower shed is constantly the slacker, and there is a persistent tendency for the weft wire to appear on the top surface of the cloth.

The cloth beam, on which the woven cloth is wound at the front of the machine, is a heavy cast-iron roll. A groove is cut along the roll, and in this groove a bar is fixed by countersunk screws for the attachment of the warp wires when the weaving is started. In this connection, it is noteworthy that there must always be a certain length of unwoven wire, at both ends of the cloth, on account of the distance from the picking line, where the weft is shot across, to the two beams, and it is naturally the aim of manufacturers to reduce this waste wire to a minimum.

A variety of different schemes is employed for paying out the wires from the warp beam, as the weaving proceeds, and at the same time keeping the proper tension on the warp, while the woven cloth is rolled up at the front. Part of the gear can be seen

BRITISH WIRE-DRAWING AND WIRE-WORKING MACHINERY

in the left foreground in Fig. 94, but a more complete view is given in Fig. 99, which shows a different and heavier machine. The movement of the warp beam is regulated by the ratchet seen at the rear, which is driven by a variable stroke crank. This crank is, of course, set according to the mesh to be woven. The ratchet wheel, it will be noticed, has a very wide face, and is engaged by several pawls, set a fraction of a pitch in advance of one another, so that a very regular movement is obtained.

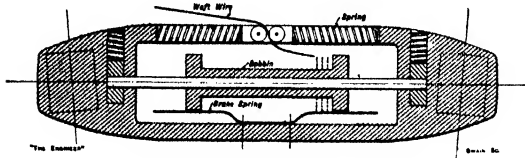

FIG. 100.

As the weaving proceeds and the warp is consumed, the diameter of the roll is naturally reduced, and an adjustment has to be made, or the mesh would vary. This adjustment is made by means of the sliding crosshead seen on the ratchet arm.

The weaver has to count the meshes woven, say, every quarter of an hour, and make the necessary adjustment.

The taking-up gear on the cloth beam works on much the same principle, but a V groove is used instead of a ratchet. A refinement recently introduced by the Anderston Company is a connection between the let-off and the uptake gears to make

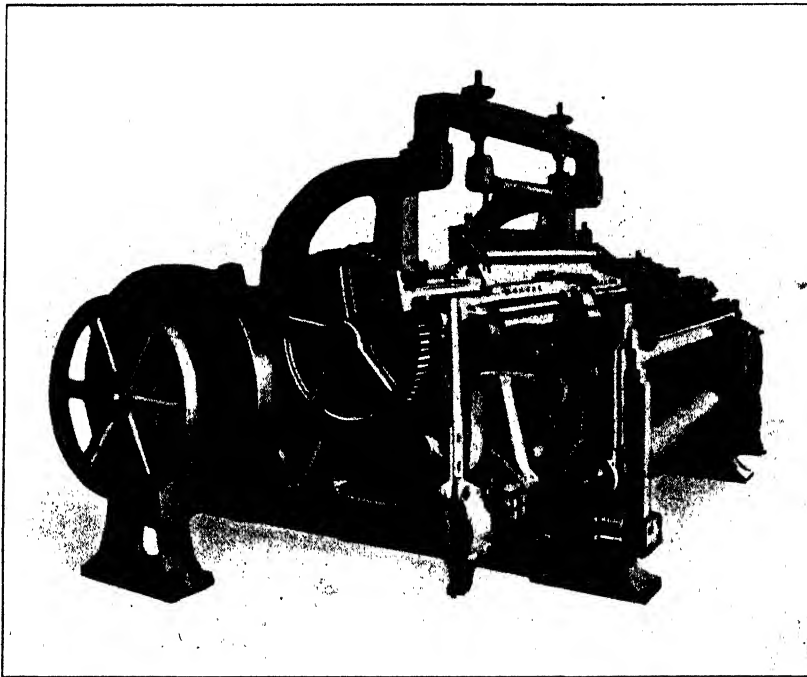

FIG. 101.—HEAVY AUTOMATIC LOOM—ANDERSTON.

the adjustments in the speed of the two beams simultaneously, so that there is no fear of the wires being broken by being drawn forward faster than they are let off. Another improvement is a mechanism which, by bearing against the outside of the roll of cloth, controls the taking-up ratchet automatically.

The let-off and uptake movements are driven independently, and do not necessarily work in unison with one another; in fact, it is advisable that they should not do so, for the following reason:—

. When the sheds begin to cross, the tension in the web naturally slackens, and the

WIRE-WEAVING LOOMS

wire should be let off from the warp beam at that moment. The movement of letting off must, however, be completed before the reed strikes the edge of the cloth, in the action of beating up, so that the web may be rigid to resist the blow. On the other hand, the take-up should be timed a trifle later, as the beat-up tends to slacken the cloth in front of the reed, and that is when the cloth beam should take up. The actual delay between the let-off and the take-up is approximately half a stroke.

It is occasionally necessary to turn the loom backwards to open the shed again and pick out a broken weft wire. If this were done without releasing the take-up and let-off pawls, there would be a double mesh when the machine was started again. In the Anderston looms, however, the ratchet wheels are free to reverse for nearly a revolution without operating, so that this trouble is overcome automatically.

The weft wire is carried in different manners according to its gauge. Thus wires up to No. 25 S.W.G. are wound on tapered pirns, in the same manner as cotton, carried

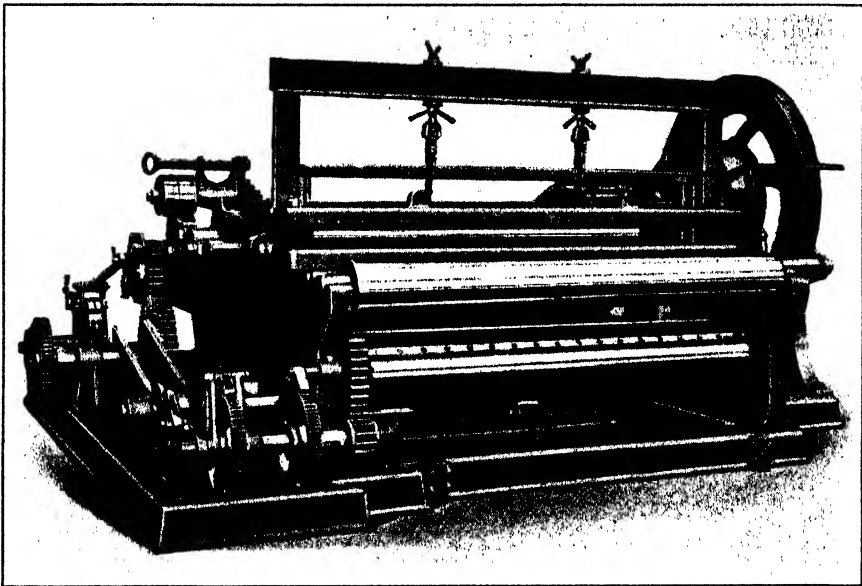

FIG. 102.—HEAVY SEMI-AUTOMATIC LOOM—ANDERSTON.

by a flying shuttle. The wire comes off the end of the pirn, which does not rotate. For heavier wires, up to, say, 20 gauge, this system is not practicable, and it becomes necessary to wind the wire on a bobbin or spool, which is carried in the shuttle and is free to rotate. In the Anderston loom the bobbin is arranged as indicated in Fig. 100. It will be noticed that there is a light leaf spring bearing against the flanges which produces just enough braking action to stop the bobbin spinning at each end of its stroke. The wire is led off the shuttle between two little grooved wheels, which are mounted in a sliding carriage controlled by light springs, so that the wire is led fairly off the bobbin. The rolls on which the shuttle runs are set at a slight angle to make the back of the shuttle bear against the face of the reed as it is shot through the shed. The speed of a loom using such a shuttle is about sixty picks per minute.

Still heavier wires can be shuttled, but the limit is reached at about No. 15 S.W.G., and such wires are generally wound on narrow bobbins lying flat in steel shuttles. These bobbins may be about 5 in. in diameter by 2 in. wide, and the effort necessary to shoot them across the cloth, together with their retardation at the end of the stroke,

are serious problems for the loom designer. As a consequence, the machine—see Fig. 101—cannot be worked at a speed much above thirty picks a minute.

There is a demand for cloths made of still heavier wire, and for this work a semi-automatic loom—such as that shown in Fig. 102—has to be employed. The weft wire is then passed through the shed of the warp by hand. The wire is wound on a needle, something like that used by a fisherman in netting, and this needle is pushed through at each stroke of the machine by the attendant.

Even stouter wire, up to $\frac{1}{4}$ in. in diameter, is woven, but then it is cut off in lengths appropriate to the width of the cloth, and if a close mesh is required the wire is crimped before it is woven.

A small crimping machine by W. H. A. Robertson and Co., of Bedford, is shown in Fig. 103, and needs hardly any description. It consists of two spindles geared together mounted in a frame. The rolls are of hardened steel having teeth to conform with the crimp required. It is usual to fit three rolls with standard size pitches between the housings and leave a space on the outer ends of the spindles to carry special sets. The engraving shows a hand-operated machine, but a belt pulley can, of course, be fitted, if necessary.

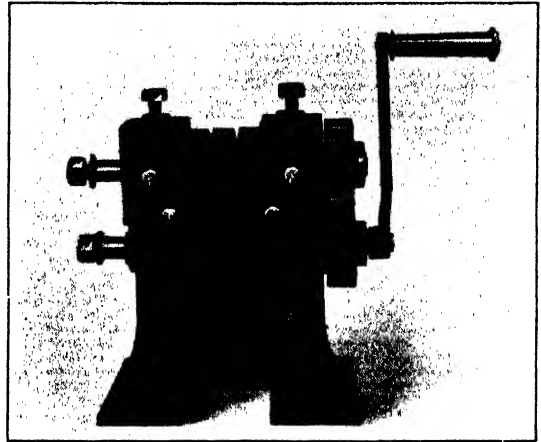

FIG. 103.—CRIMPING MACHINE—ROBERTSON.

Cloth made in the manner just described has not, of course, any selvedge, and the ends of the warp wires have to be twisted over by hand if a finished edge is required.

The production of a good selvedge to wire cloth always presents difficulties for

several reasons. There is, for instance, the liability for the weft wire to kink, as the shuttle must over-run the width of the cloth, and consequently leaves a loose loop of wire as it starts on its return journey. When a pirn shuttle is being used, there is an added tendency for kinks to form, as the wire is given a twist as it comes off the pirn. One of the most common ways of overcoming this difficulty is for the girl attending the loom to put her finger lightly on the wire as the shuttle emerges from the shed and hold it until the tension comes on again on the return pick of the shuttle. Her

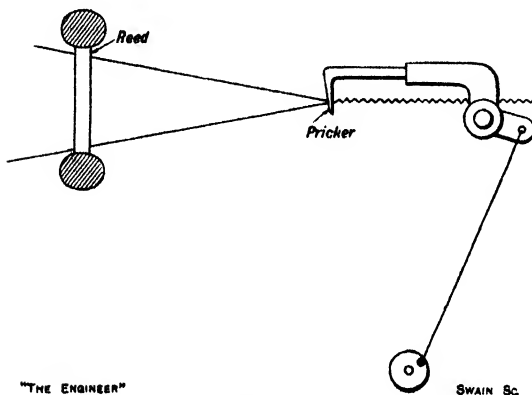
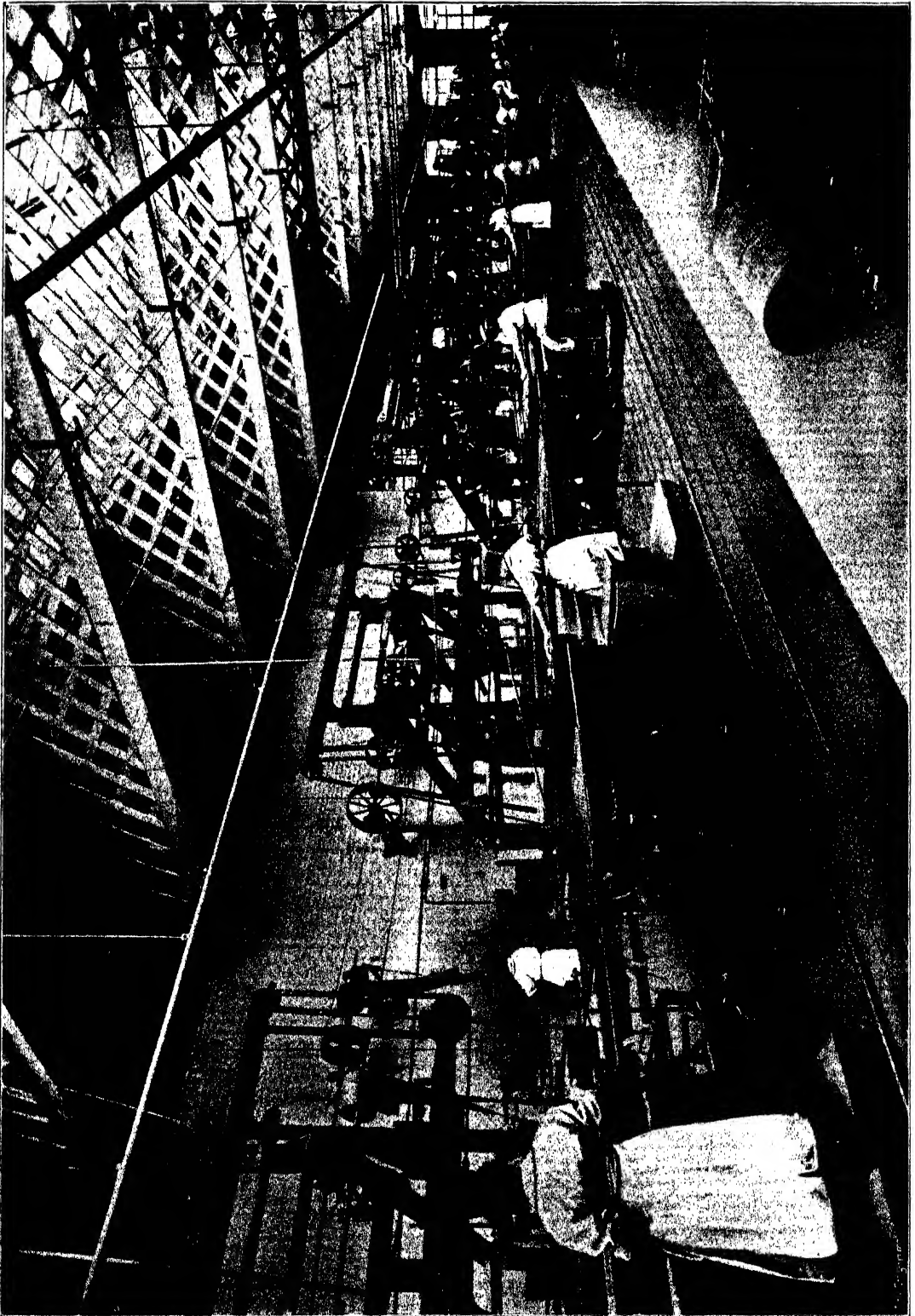

FIG. 104.

attitude in doing so can be plainly seen in the engraving on the opposite page. In the Anderston loom, however, there are two devices like the "tension" of a sewing machine. They can be seen in Fig. 94 near either end of the breast roller, and are cup-shaped pieces pressed together lightly. The wire slips between the two and is held just sufficiently tightly to prevent kinking, but not so much as to check the shuttle.

Another difficulty in making a good selvedge is caused by the tendency for the

WIRE-WEAVING LOOMS



A ROW OF MCGEE WIRE-WEAVING LOOMS IN MESSRS. RICHARD JOHNSON'S WORKS.

BRITISH WIRE-DRAWING AND WIRE-WORKING MACHINERY

outside warp wires to be dragged out of line by the pull of the weft. One method of overcoming this trouble is to arrange a pricker to come down next to the edge of the cloth at each pick—as roughly indicated in Fig. 104—for the weft wire to be looped round. The point has, of course, to be so geared with the mechanism that it is lifted out of the way at each pick. Another system is to feed a length of strong piano wire into the selvedge at the start of weaving and attach the back end to the frame of the machine as soon as the front end approaches the cloth beam. Then the weft wires are all turned over this piano wire, which is kept taut by the cloth being pulled forward and off at the end. In other words, the piano wire remains stationary while the cloth is pulled over it.

In any case the selvedge wires are seldom taken directly off the warp beam, for they would then tend to get slack, as they are not subjected to the same crimping action as are the weft wires. The selvedge wires are consequently generally accommodated in separate bobbins mounted at the back of the machine and wound round pieces of buffalo hide to give them the necessary tension.

With heavy grade goods there is always a tendency for the selvages to pile up on both sides of the roll of cloth, an effect which is more or less present even in much lighter fabrics. If the piling up of the selvages on the roll of cloth, as it winds up on the cloth beam, were allowed to continue, the cloth when unwound from the loom would not lie flat. To obviate this ill effect some weavers insert a web of calico between each layer of cloth as it winds up on the cloth beam. In the case of the machine shown in Fig. 99 the makers provide a selvedge-flattening apparatus which beats down the selvages on the cloth beam at every stroke of the loom, and the gear is so arranged that the same effect is given no matter to what diameter the roll of cloth may build up.

The reed used for beating up the weft wire into the corner of the shed of the warp is an important part of a wire loom, as it has heavy work to do. It is built up of a number of thin steel plates, known as dents, a dent being arranged between each pair of adjacent warp wires. There are several methods of building up the reed, such as binding the dents together with twine, and soldering them, but neither seems to be a really mechanical job. The reed is carried by the lay batten and is rocked forward about a fulcrum in the base of the loom; after each weft wire has been shuttled through the shed opening the reed drives the wire firmly into place in the angle between the warp wires. It is obvious that the reed must be deep enough to allow for the separation of the warps to form the shed, and if the beat-up took place at the centre of its depth, there would be a tendency for the dents to give under the blow. For this reason the position of the fulcrum is so chosen that the beat-up is effected near the bottom end of the dents, and sometimes a special excentric fulcrum is adopted so that the reed is raised as it is rocked forward, and thus given a movement approximately parallel with the bottom of the shed.

In the case of the machine illustrated by Fig. 102 the lay batten slides on inclined guides provided on the loom side frames, the inclination of these slides being parallel with the inclination of the bottom shed of warp wires, thus ensuring that the blow from the reed when laying the weft wire up to mesh will be received right down at the root of the reed. It will also be noticed that the machine is provided with a very heavy fly-wheel, and the whole energy of this fly-wheel is available to do the work in knocking the weft wire up to mesh.

In the McGee loom—shown in Fig. 95—the method of working the shuttle is of the positive type and is quite peculiar. It will be observed that on either side of the machine there is a long carrier bar or shuttle arm working horizontally between pairs of rollers. These bars are connected with a double crank over the centre of the machine,

WIRE-WEAVING LOOMS

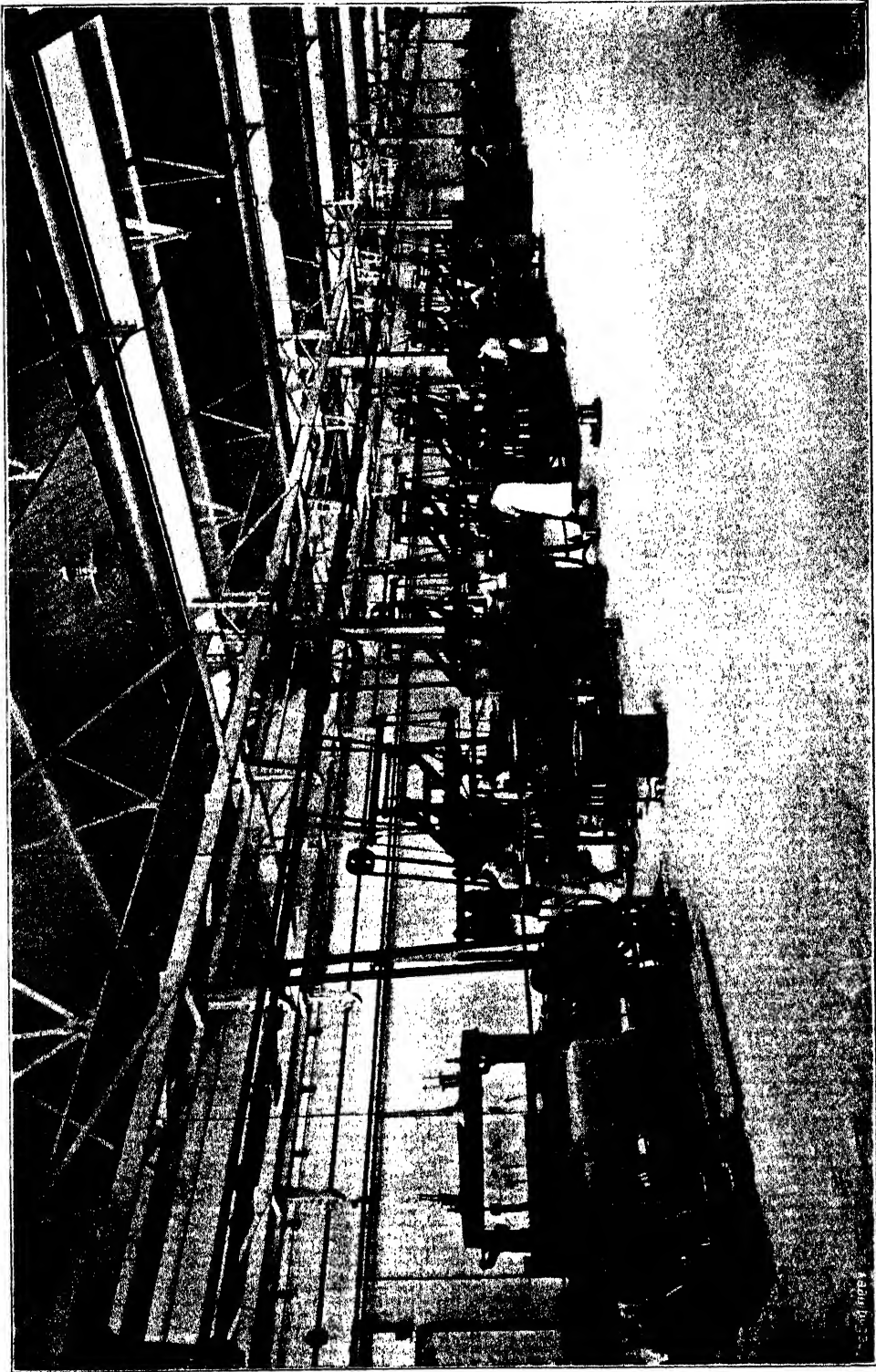

BOBBIN-WINDING DEPARTMENT IN MESSRS. RICHARD JOHNSON'S WORKS.

BRITISH WIRE-DRAWING AND WIRE-WORKING MACHINERY

and the crank is rotated by a pinion and rack connected by overhead chains with a crank shaft in the base of the loom. The various parts are so proportioned that the double crank makes a complete revolution for each pick and, in doing so, pushes the two horizontal rods together until they meet at the centre and then pulls them apart again. On the end of each rod there is a spring clip for holding the shuttle of weft wire.

In a positive carried shuttle loom it is imperative that the two carrier bars should meet for the shuttle exchange without shock. The design of the crank motion, combined with the angular position of the connecting-rods, is consequently arranged to reduce any shock to a minimum, and this is assisted by the two bars moving together

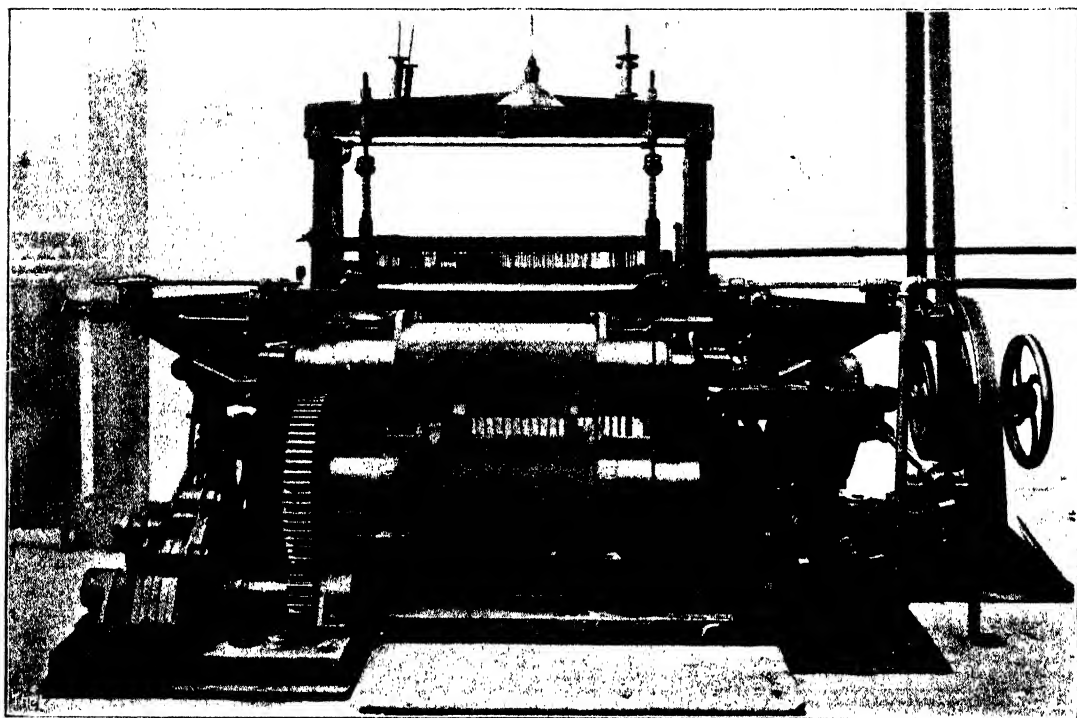

FIG. 105.—HEAVY BAR LOOM—R. JOHNSON.

as one, for a very short period during the actual transfer, before they separate and move apart. The spring catch at the mouth end of the carrier bar, which holds the shuttle, is operated by means of a rod passing through the centre of the bar and a catch gear on each side of the loom. In the transfer both carrier bars close on to the shuttle and the catch gear operates so as to release the spring of the bar which is to pass the shuttle over to the other bar, after which the bars recede, thus carrying the shuttle from side to side of the cloth. The arrangement has the advantage that heavier wires can be handled than is possible when the momentum of a shuttle is depended upon to carry the weft wire through the shed.

Another loom of a special type is shown in Fig. 105 and is known as a heavy bar loom. This loom is fully automatic with a positive shuttle action, but is designed without overhead gear, while the carrier bar drive is obtained by a special patented motion at each side of the loom. These machines are used for weaving heavy cloths

WIRE-WEAVING LOOMS

such as rice cloth, and it is the intention of Messrs. Johnson to develop this special type of loom as the necessity of business demands.

The loom shown in Fig. 106 is by George Hattersley and Sons, of Keighley, and will work with wire up to No. 28 gauge at a speed of some 120 picks per minute and up to a mesh of 120 per inch. It is of the underpick type, and has a warp beam built up of cast iron distance pieces with mild steel discs keyed on to a shaft 3 in. in diameter.

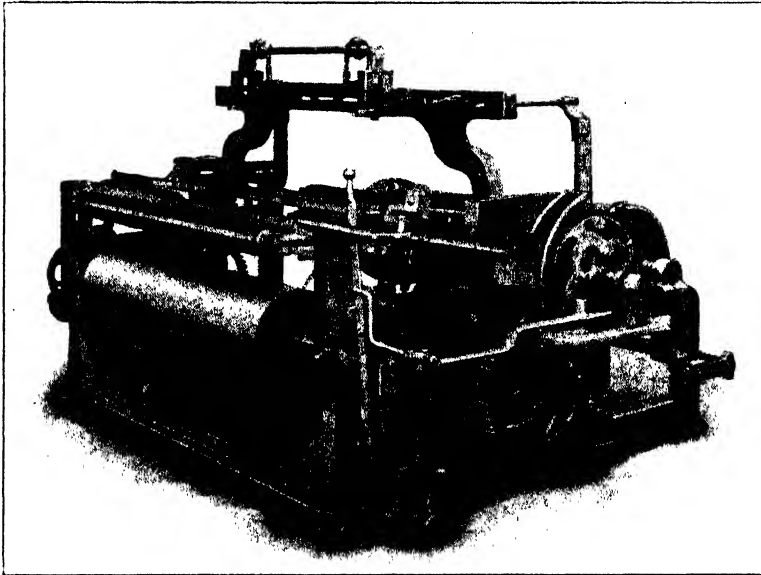

FIG. 105. WIRE-WEAVING LOOM--HATTERSLEY.

A wire-weaving works naturally involves the provision of machines for filling the shuttle bobbins, but as they closely resemble those used in cable making they need not be described in detail here.

In passing, it should be mentioned that the works of Richard Johnson, Clapham and Morris are not confined to the production of woven wire cloth, but at them are also manufactured copper wire, wire work, wire netting, machinery guards, light iron work, miners' lamps and brass castings.

CHAPTER XI

ELECTRIC CABLE MAKING

THE Charlton works of Johnson and Phillips provide an excellent opportunity for studying the process and machinery for manufacturing electric cables, as not only does the firm make cables on a large scale, but the necessary machinery is all made there, and complete plants are supplied for other cable makers. The designers in the drawing-office consequently have a good opportunity for studying the effects of any

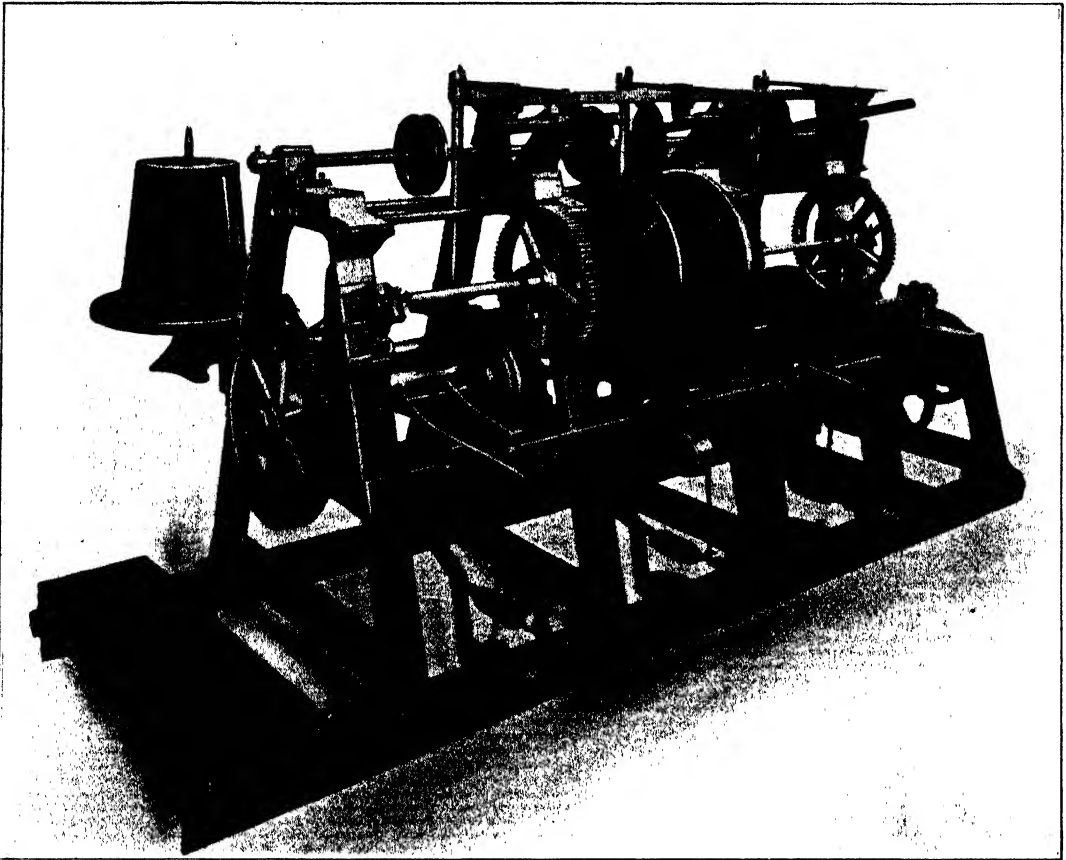

FIG. 107.—HIGH-SPEED TRIPLE AUTOMATIC WIRE WINDER—JOHNSON AND PHILLIPS.

innovations they may produce, and improvements can readily be made in light of the experience thus gained.

The first step in cable making is to wind the wire on to bobbins for insertion in the stranding machine. This operation is sometimes done by hand, but the automatic winding machine—shown in Fig. 107—saves a considerable amount of labour in the case of comparatively light wires. It is, however, noteworthy that with a simple

ELECTRIC CABLE MAKING

belt-driven spindle for mounting the bobbin on, and a piece of rag in his hand to guide the wire, a lad can get very nearly as much wire on to a bobbin as is the case when the automatic winder accurately lays all the turns as close together as is possible.

In hand winding the wire is taken from the coil on a swift, round a measuring pulley, generally two yards in circumference, and then through the attendant's hand to the bobbin. A simple brake is provided so that the swift can be stopped from over-running at the end of a wind, and a revolution counter on the measuring wheel is used to show the amount of wire put upon the bobbin.

The automatic machine—illustrated by Fig. 107—is arranged to accommodate three bobbins up to 20 in. in diameter by 10 in. wide between the flanges. It is really three separate machines grouped together in a frame and driven independently off one shaft. This shaft can be seen extending from the left of the machine, where it carries a gear wheel for meshing with the pinion of an electric motor fixed on the base below. There are three gear wheels on this shaft for driving the bobbin spindles. The connection between the shaft and the wheels is made by means of clutches with hand levers above, so that the bobbins can be started separately. All the gearing has machine-cut teeth.

The bobbin spindles, it will be seen, are mounted in bearings, with hinged keeps clamped by swing bolts and butterfly nuts, so that they may be quickly taken out for the bobbin to be threaded into place. A driver, with a projecting pin, keyed to the spindle engages with a hole in the side of the bobbin flange. The speed of the bobbin is approximately 250 revolutions per minute.

The wire is led on to the bobbins over the grooved pulleys seen at the top of the machine, and these pulleys are traversed backwards and forwards for flaking the wire on to the bobbin. The traversing mechanism is at the back end of the machine, and comprises a right and left-hand screw, which is shown in the elevation—Fig. 109. This screw is driven from the main shaft through a set of change wheels, so that its speed can be altered to suit the wire being wound. The nut on this screw engages with the bottom end of a vertical rocking lever, the top end of which is connected with the shaft carrying the grooved pulleys. By altering the position of the lever fulcrum the length of stroke can be adjusted to suit the width of the bobbins being wound.

At the back of the machine there are the swifts on which the coils of wire to be wound on to the bobbins are placed. One of these swifts is plainly shown in the engraving—Fig. 107. The arrangements made for stopping the machine in the case of any untoward event are best illustrated by the line drawing—Fig. 109—from which it will be seen that the coils of wire are led from their respective swifts, A, B and C, through die-holes D, round the pulleys E and F, up to the roller G and on to the bobbin H. Supported by the wire and resting on top of it is a small roller J carried off an arm fulcrumed at K, and in the event of a wire breaking this allows the small roller J to drop down. The roller is connected by a piece of steel cable to a lever L, which is fulcrumed at M, and the movement of this lever releases a spring plunger. At the moment the plunger falls the clutch lever N is pulled over by means of a tension spring—being held in position normally by the spring plunger above referred to—and throws the clutch out of gear, thus stopping the bobbin from being driven. It should be here noted that when the machine is stopped the brake comes automatically on to the swifts. This action is accomplished by means of the arm which carries the pulley F fulcrumed off the same centre as the pulley E. In other words, when the machine is running the tension in the wire is such that it causes the lever carrying the pulley F to swing up, as shown by the arrow, and in doing this the opposite end of the

BRITISH WIRE-DRAWING AND WIRE-WORKING MACHINERY

lever obviously swings in towards the swifts and pulls on the coupling rod O, which pushes the rod P towards the swifts, thus releasing the band brake of the corresponding swift. In the event of a wire breaking, the lever carrying the pulley F obviously falls down, and the reverse cycle of operations takes place, the swift brake being applied automatically. The requisite tension is obtained by means of adjusting the screw Q, fitted with a wing nut and tension spring.

A modification of this arrangement as applied to smaller machines for wire winding is as shown in Fig. 110. In this case it will be seen that the wire takes a path from the swift over two pulleys, as in the larger machine, in such a way that under normal running conditions the lever arm swings up to the dotted position, thus releasing the tension on the brakes. In the event of a wire breaking, the roller A, which is supported by the wire, drops down, and being fulcrumed at B, the opposite arm of the lever swings up. The end of this lever is coupled to a plunger by means of a short length of $\frac{1}{2}$ in. pitch chain. The plunger, on being released, allows the pin C to travel outwards as a result of a compression spring D coming into play. On the end of this pin C is a wedge-shaped piece which, as it travels outward, permits the idle roller E, which

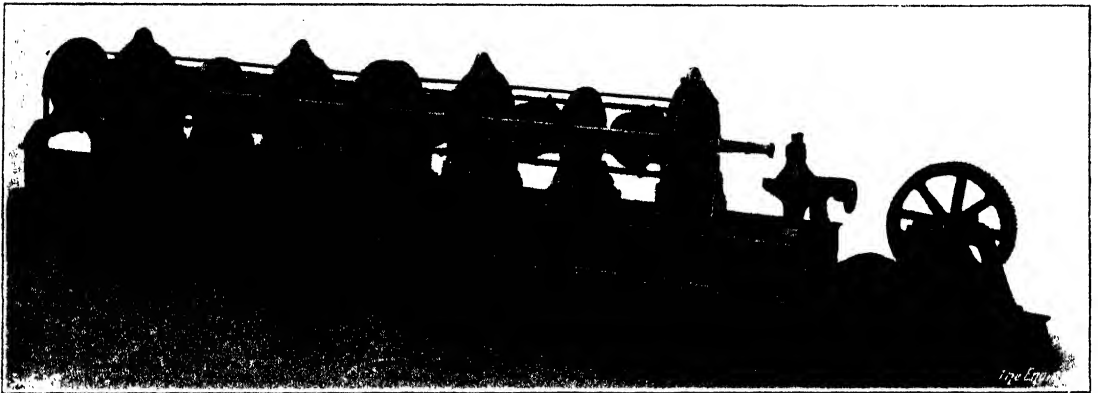
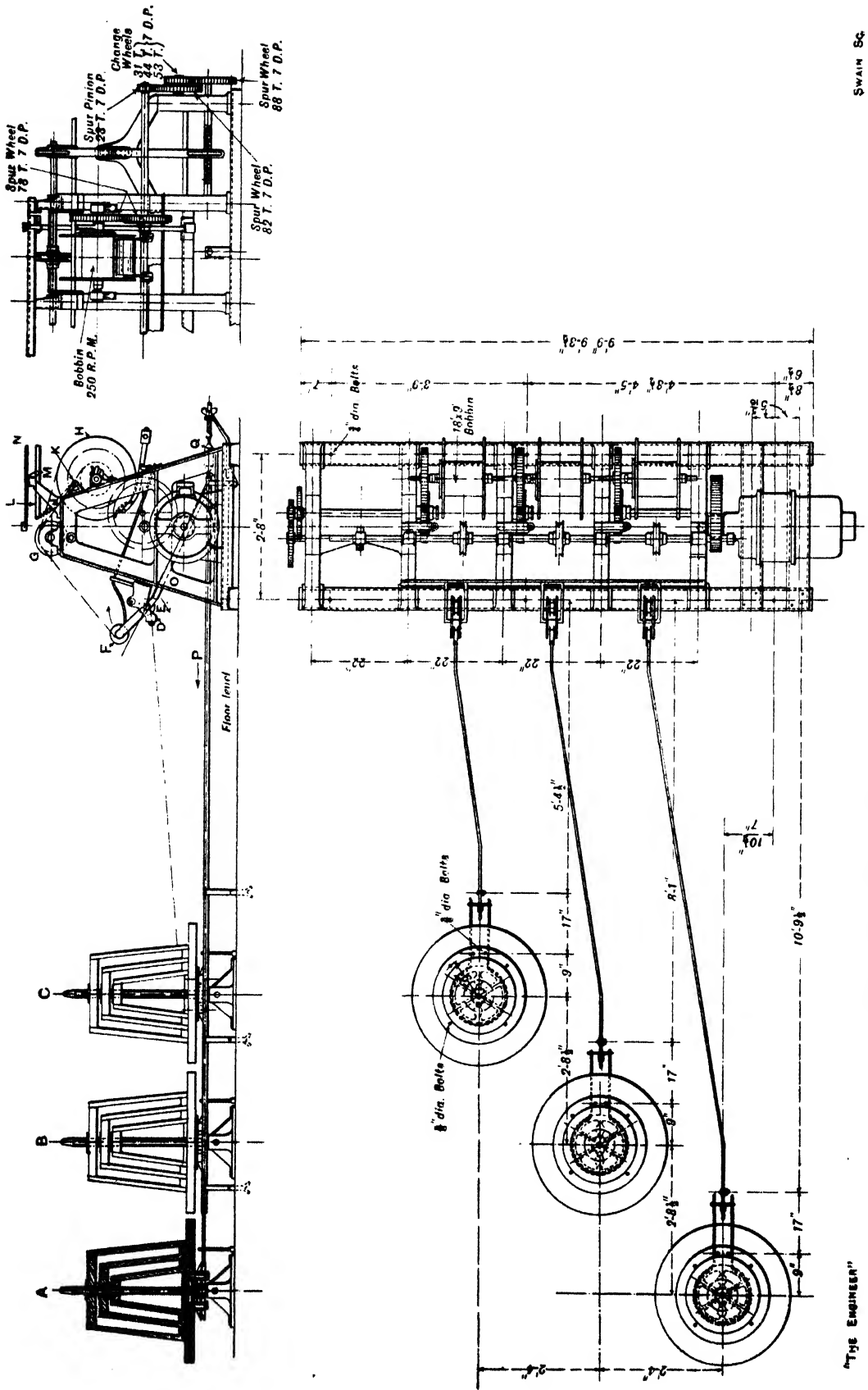

FIG. 108.—HIGH-SPEED STRANDER—JOHNSON AND PHILLIPS.

is rubber-faced, to drop down and lose contact with the friction driving pulleys F and also the friction disc G on the bobbin spindle. At the same time, as explained for the larger machine, the swift brakes come into operation simultaneously.

The first stage in the process of laying the wires together to form a cable is carried out in the machine illustrated by Fig. 108, which winds together seven strands—that is to say, six strands round a central wire.

The machine comprises a long cage built up of a series of discs—eight in this case—connected together by bars, mounted on non-metallic anti-friction rollers. Inside the cage the bobbins of wire are mounted in carriages, which are supported by ball bearings concentric with the discs. The carriages are heavily weighted at the bottom so as to ensure that they will remain stationary while the cage is rotated. The wire coming from each bobbin is led through guides and then along the bars of the cage, which are provided with fairleads for the purpose, to the disc at the delivery end of the cage. The wires emerge there at the periphery of the disc and converge on a lay plate fixed on an axle, which can be plainly seen in Fig. 108, extending from the front of the front disc. The central wire comes off the first bobbin and goes directly through the centre of the disc. The wires then go through a die to the fleeting, or drawing off, wheel at the end of the machine. The die is mounted on a bracket which can be



SWAIN & C.

FIG. 109.—LARGE TRIPLE BOBBIN-WINDING MACHINE—JOHNSON AND PHILLIPS.

"Type Engineer"

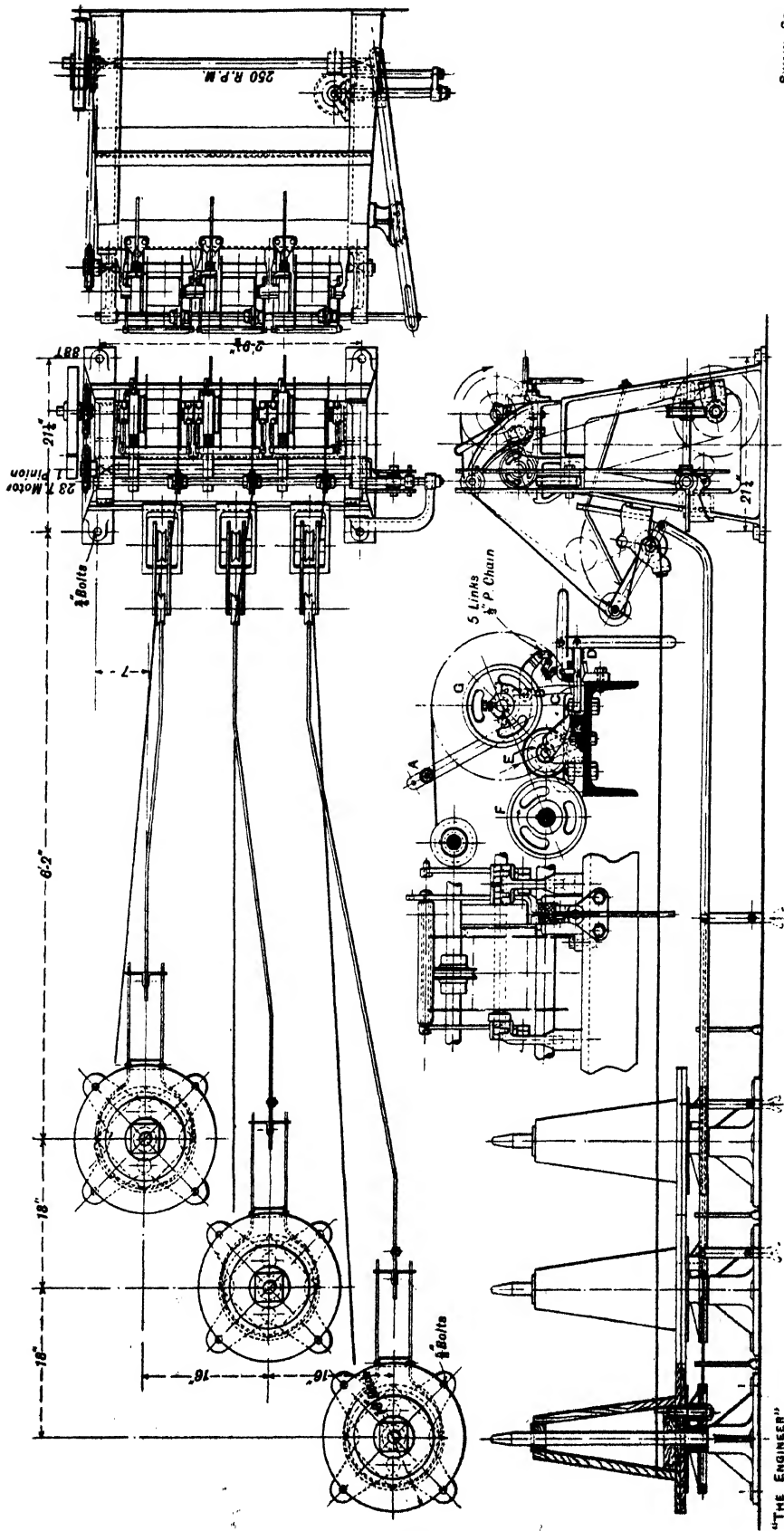

FIG. 110.—SMALL TRIPLE BOBBIN WINDER—JOHNSON AND PHILLIPS.

SWAIN 5c

"THE ENGINEER"

ELECTRIC CABLE MAKING

adjusted longitudinally to suit the angle of twist, or lay, of the strands, and is itself split so that it can be put in place over the cable. The die is bored out to the exact diameter of the finished cable.

The whole cage is rotated by means of a motor, which is geared to the central disc, and, as a consequence, the wires are wound together at the die in a helix of a pitch which corresponds with the rate of draw-off by the fleeting wheel. There is a thrust bearing in connection with the trunnion of the back disc to take up the pull on the whole of the wires.

The fleeting wheel is driven from the same motor as the main cage, through a set of changeable reduction gears, and round it the cable is taken for one or two turns on its way to a coiling drum. The form of the fleeting wheel is a distinctly critical part of the whole machine, as it must be such that it provides an absolutely positive pull through for the cable without there being any liability for the turns to ride up its inclined face and run over the side.

While the fleeting wheel pulls on the completed cable it is obvious that a check

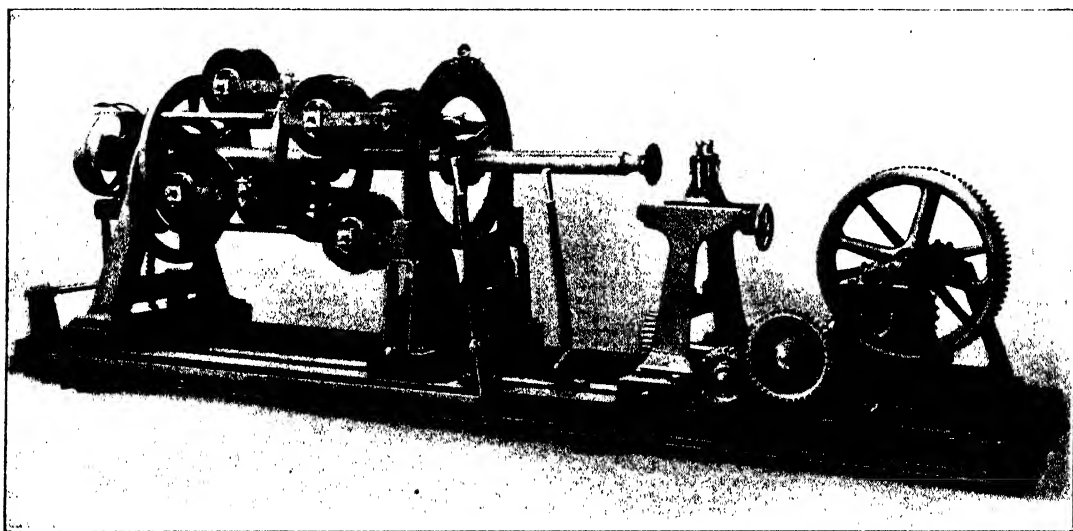

FIG. 111.—SIX-BOBBIN STRANDER.

must be put on the feed of the wires as they come from the bobbins, otherwise the lay of the cable might be quite slack. To effect this purpose a piece of cord is lapped round a brake drum on each bobbin spindle, and one end of the cord is attached to a lever carrying a guide for the wire in question. The arrangement is such that if the wire tends to run slack the brake is put on to increase the tension and *vice versa*. By the same rule when the machine is stopped the brake is put on hard and stops the bobbin over-running. A special automatic device is sometimes added for stopping the whole machine in the event of any of the wires breaking accidentally.

The cages of these machines run at a speed of about 1,000 revolutions per minute, and it is really astonishing, in view of the number of separate parts which go to make up their structure, how steadily they run. It is, however, obvious that they need a really solid foundation to keep all the bearings in line, although the main frame is formed of good stiff joists.

A similar type of machine is also used for laying up 19-wire strands. In this case a 7-wire strand, previously made on a corresponding machine, is carried by a large

BRITISH WIRE-DRAWING AND WIRE-WORKING MACHINERY

bobbin in the front section of a 13-bobbin machine, with twelve smaller bobbins behind it, so that twelve wires are stranded round seven. The use of such machines becomes, however, commercially impracticable after a bobbin of 10 in. to 12 in. is reached owing to the extreme length to which the machine extends.

When it is necessary to produce a larger size of strand than is possible with the machine just described, the machine illustrated by Fig. 111, page 109, is used. In it bobbins of from 12 in. to 24 in. in diameter can be accommodated. With this machine seven wires can be stranded together, although there are only six bobbins, as there is a clear way through the mandrel. The seventh wire is led from a bobbin, mounted on a stand at the back of the machine, straight through the mandrel to the centre of the die plate. The other wires go directly from the bobbins to openings in the front disc, which are bushed with bell-mouthed, case-hardened steel dies, and thence to the lay plate. It is noteworthy in this connection that although the machine has only to deal with copper wire, the dies and lay plate are subject to severe wear. The copper

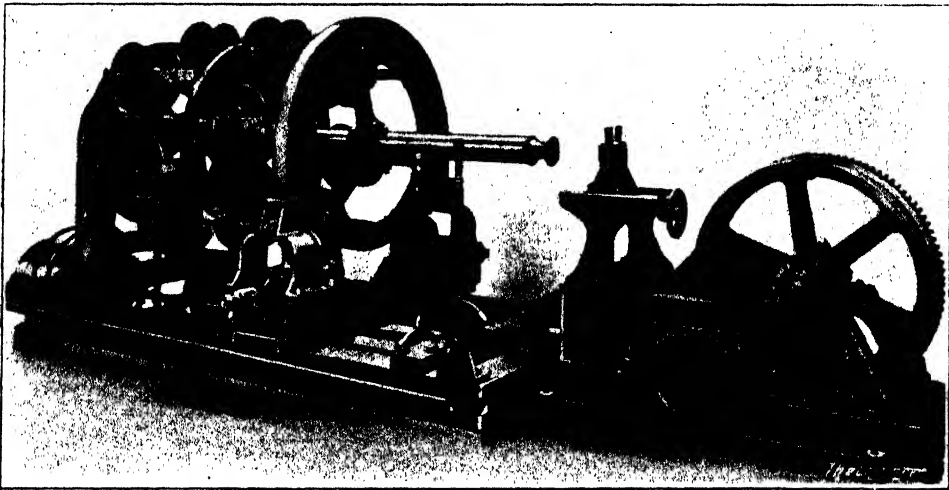

FIG. 112.—TWELVE-BOBBIN STRANDER—JOHNSON AND PHILLIPS.

cuts very perceptible grooves in the harder metal, and many efforts have been made to find a material which will stand up to the service. It appears, however, that case-hardened steel is the most satisfactory for both dies and lay plates. The contour of the bell mouths has naturally some influence on the wear, and care is taken to make the curvature as easy as possible.

It will be noticed that each of the bobbins is mounted in a cage pivoted in the main rotating frame. Each cage has a spindle that projects through the rear disc, and on the end of this spindle there is a crank arm. These cranks engage with another disc, set excentrically to the mandrel to the extent of the throw of the cranks.

This arrangement, known as a "floating" or "detorsion" gear, is very similar to that of the feathering action of a steamer's paddle wheel, and insures that the axes of the bobbins will retain a horizontal direction as they rotate bodily round the mandrel. When desired the machine may, however, be arranged to run with the bobbins "fixed" or radial to the central axis by the simple process of removing the excentric ring and placing it centrally into lipped joggles on the heads of the cast steel cranks;

ELECTRIC CABLE MAKING

The die bracket is adjustable, and the draw gear is fitted with a complete set of machine-cut spur change wheels for varying the length of lay.

The weight of the revolving cage is carried at the back by a white metal lined bearing, and at the front on two adjustable anti-friction rollers arranged beneath the front disc. The machine illustrated is intended for belt driving, but it can, of course,

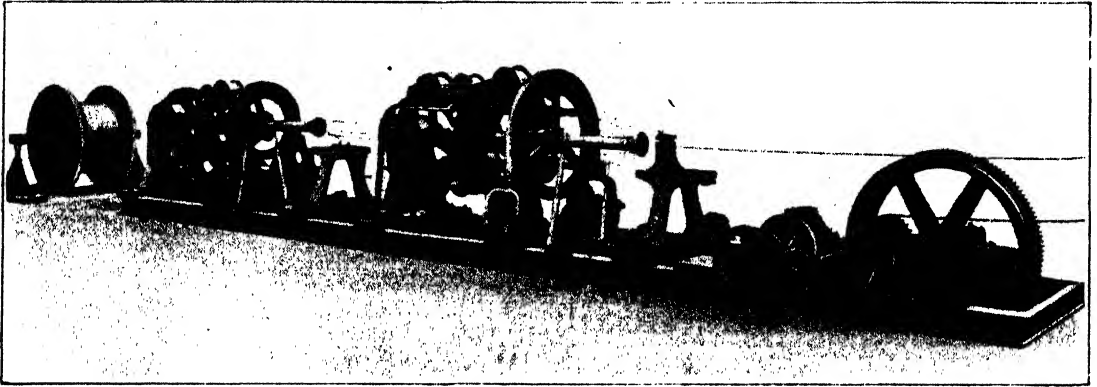

FIG. 113.—DOUBLE-TANDEM STRANDER.

be arranged to be driven directly by a motor. In connection with the drive there is a powerful brake, so that the machine can be stopped quickly in case of necessity.

Fig. 112 represents a machine of the same type as that just described, but with twelve bobbins, arranged in two circles of six, for laying up 19-wire strands with 7 wires coming from a fixed bobbin at the back. This illustration also shows the means adopted

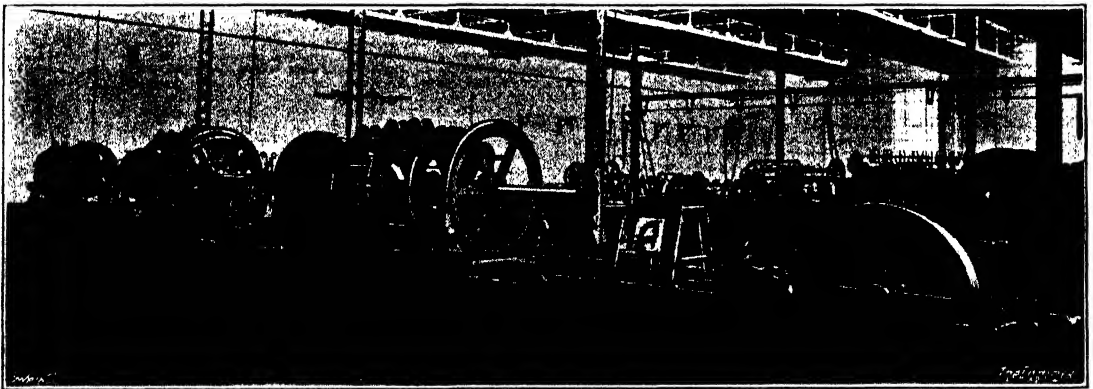

FIG. 114.—LARGE TRIPLE-TANDEM STRANDER.

for adjusting the anti-friction rollers and keeping the cage in line. It will be noticed that the cage is driven from the shaft below through a silent chain.

Another machine of more elaborate form—see Fig. 113—is known as a double-tandem strander, and can be used for laying together several combinations of wires. It really comprises the two machines last described grouped together on one bed. In the front there is a 12-bobbin strander, with a 6-bobbin machine behind, and at the back there is accommodation for a drum of ready-layed strand. Thus eighteen wires can be put on at one time, and by laying them over a 19-wire core, 37-wire strands can be made. The two sections are, however, independent, and can be used separately

BRITISH WIRE-DRAWING AND WIRE-WORKING MACHINERY

for laying up smaller strands. There is one driving pulley, but between the two machines there is a set of gear wheels providing a clutch action and reversal, so that the two sets of wires can be laid in opposite directions if that be desired. The relative speeds of the two machines can also be varied by the gears.

A still more elaborate development of the same idea is represented in Fig. 114, which shows a triple-tandem stranding machine having twelve, eighteen and twenty-four bobbins in the several sections.

For exceptionally large cables the strands already laid up are put on the bobbins of the machine illustrated in Fig. 115 and are closed together. The essential principle of the closing machine is the same as that of the stranding machine, but it is naturally of heavier construction. The floating gear for the bobbin cages is, however, of a different design, and takes the form of the sun and planet wheels seen inside the front disc.

It will be noticed that the sun wheel is of twice the diameter of the planet wheels.

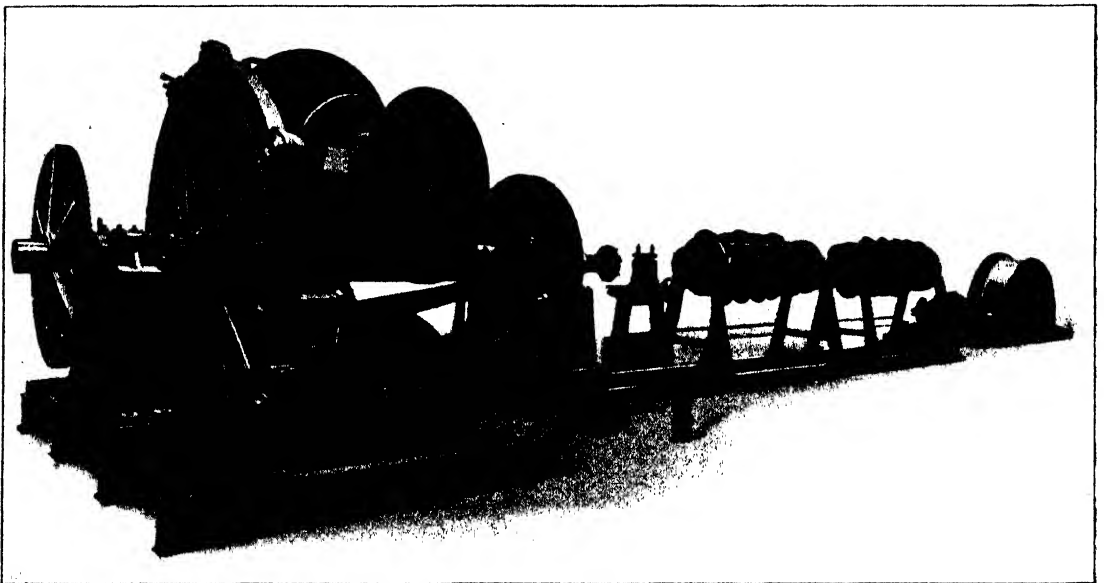

FIG. 115.—THREE OR FOUR BOBBIN CLOSING MACHINE—JOHNSON AND PHILLIPS.

which, at first sight, makes it appear that the bobbin cages would be rotated. The sun wheel, however, is not stationary. It is mounted on a sleeve on the mandrel, and this sleeve is driven off the fixed gear wheel, seen just inside the back bearing, by means of a two-to-one gear passing through the back disc.

Another peculiarity of the machine is the inclination of the bobbin carriages towards the layhead, so that the strands have a very direct and easy passage towards the closing point, and unnecessary bending is avoided.

As shown in the illustration, the machine is equipped with four bobbins, but the end plates have a second set of journals for the cages, so placed that three bobbins can be used at will. The capacity of the machine may be gauged by the fact that it will accommodate bobbins up to 6 ft. in diameter. The apparatus seen in front of the closing machine is used for lapping the cable with paper for insulating purposes.

A very fine example of large cable-making machinery, which has recently been supplied for the Woolwich works of Siemens Bros., by Johnson and Phillips, is illustrated by the line drawing—Fig. 116—and the half-tone engravings—Figs. 117, 118,

BRITISH WIRE-DRAWING AND WIRE-WORKING MACHINERY

and 119. It is intended primarily for the armouring of very large cables, and consists of a 72-bobbin section having the spools arranged in five circles of 18, 18, 14, 14 and 8 bobbins respectively between six cast-iron discs. The discs are over 11 ft. in diameter, the centres of the 18-bobbin circles being 10 ft. 6 in., the 14-bobbin

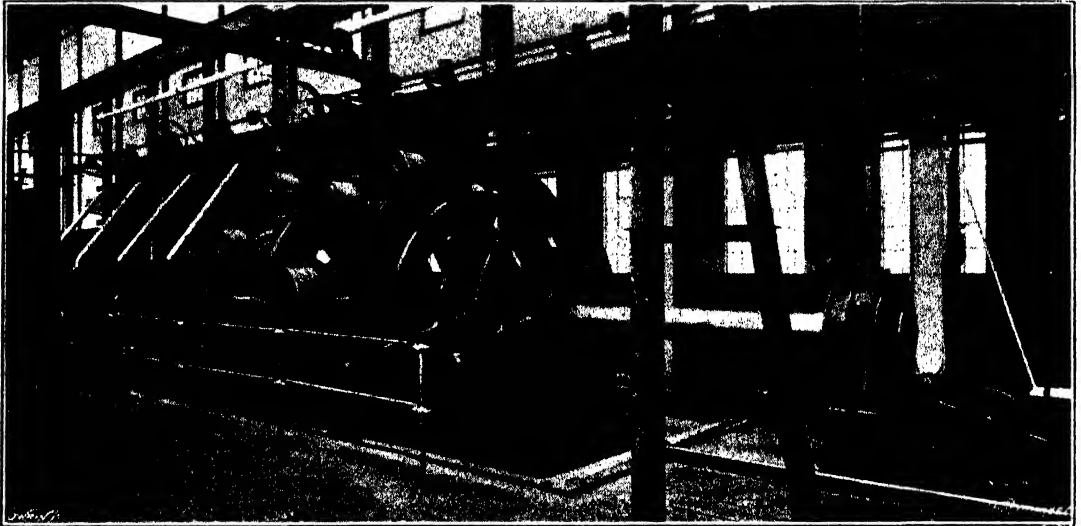

FIG. 117. —LARGE CABLE-MAKING MACHINE WITH 18 LARGE BOBBINS IN USE.

circles 8 ft. 4 in., and the 8-bobbin circle 6 ft. 2 in. The sixth or front disc is smaller in diameter, namely, 6 ft. 7 in.

The discs are keyed to a large revolving hollow steel mandrel, which is 12 in. outside diameter. This tube is supported at its leading-in end by a massive capped gun-metal

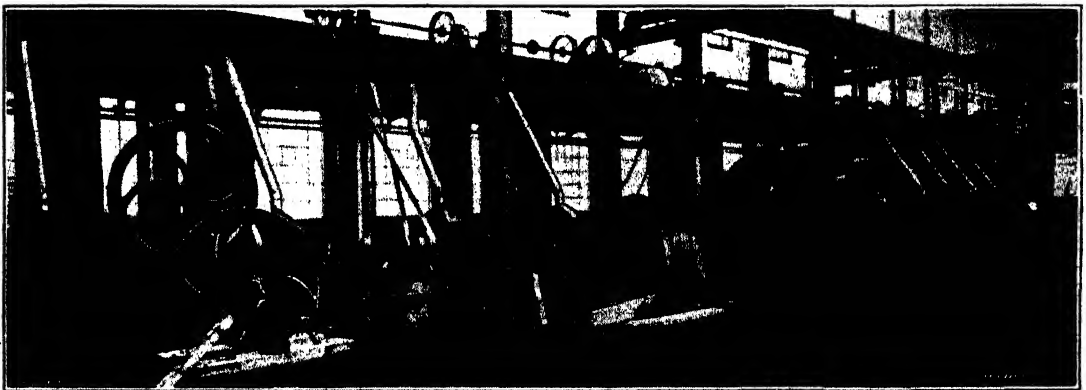

FIG. 118.—REAR, OR INLET, END OF CABLE-MAKING MACHINE.

bearing 17½ in. through. Keyed to the front end of the mandrel there is a steel casting fitted with cored holes through which the whole of the 72 wires may pass directly to the lay plate and thence to the closing die. This steel casting is fitted with double flanges turned on its periphery, and is carried in a massive gun-metal lined bearing which consequently supports the tube at the front end. The cage is further supported under the third and fifth discs by anti-friction rollers of cast steel 2 ft. 6 in. in diameter, and

ELECTRIC CABLE MAKING

the journals of these rollers are carried in Hoffmann roller bearings. These two sets of central roller bearings carry a very considerable proportion of the total load, and effectively counteract any deflection in the main tube, which would not be the case with only two bearings at the front and rear ends of the machine at 29 ft. 2 $\frac{3}{4}$ in. span.

Running throughout the central revolving mandrel is a fixed or stationary inner steel tube 5 in. bore, enabling cables up to 4 $\frac{3}{4}$ in. maximum diameter under the armouring wires to be handled. The main object of this fixed inner tube is to prevent the chafing which would be caused if the cable had to pass through a running tube.

The whole of the 72 bobbins are arranged in carriages which, by means of cranks and a crank ring, work with a floating motion, to counteract the tendency to twist during the process of armouring or stranding. A very powerful band strap brake,



FIG. 119.— FRONT END OF MACHINE WITH TAPING AND SERVING UNITS IN FOREGROUND.

Ferodo-lined, is arranged to encircle the front disc and is operated by a hand lever from the lay head of the machine.

The machine, as will be seen, is driven from the rear end through a train of heavy machine-cut spur wheels, the main drive being by belt, with fast and loose pulleys, 48 in. in diameter by 12 in. face, on a short countershaft at the rear of the machine. An additional interesting feature of this machine is the adoption of an auxiliary friction drive. A pulley 36 in. in diameter by 4 $\frac{1}{2}$ in. face is keyed on to a shaft carrying a small wedge-shaped roller 10 in. in diameter, mounted on an eccentric sleeve and running at about 150 revolutions per minute. By the lifting of a weighted lever arm operated by a steel cable from the driving end of the machine, this eccentric roller can be brought up to come into contact with the large grooved pulley 4 ft. 4 in. in diameter, which is keyed to the same shaft as the main fast and loose pulleys. Owing to the considerable purchase obtained through the spur reduction gear, it is found that this friction device is so sensitive that it enables the driver to move the main cage with perfect ease a matter

BRITISH WIRE-DRAWING AND WIRE-WORKING MACHINERY

of an inch or two at a time, a particularly useful thing during the process of loading up. In addition, this same friction device facilitates the starting up of the machine.

An unusual feature of this particular machine is that it is designed to work when desired with 18 larger bobbins, namely, 33 in. in diameter by 16 in. wide. In order to do this, the second and fourth main cast-iron discs of the machine are split so that they may be readily uncoupled and removed from the 12 in. mandrel without dismantling the machine proper. Previous to this operation, the four circles of smaller bobbins, namely, 18, 18, 14 and 14 respectively, must also be disconnected and removed, and in their place the 18 fliers or carriages for the larger bobbins put into position. It may here be mentioned that the whole of the carriages, both large and small, are fitted with loose trunnion ends to facilitate their being removed as required. The larger bobbins enable the machine to be used on a much heavier gauge of wire and a proportionally greater length without a joint. One of the engravings—Fig. 117—shows the machine with the 18 large bobbins in position. Fig. 118 is a view taken from the rear end of the machine, and illustrates the various taping, compounding and jute serving units for serving the cable before it enters into the armouring section; while Fig. 119 shows the front end of the machine and also illustrates the various serving units for serving the cable after it has been armoured. This same engraving shows the draw drum, which is 9 ft. in diameter by 26 in. wide, partially concealed in the pit. A full range of machine-cut spur wheels is provided for varying the length of lay. Overhead will be seen what is known as the haul-off gear, the cable being led from the draw-drum up on to the large sheave, which is fitted with jockey gear, and thence to the storage tanks. Above the armouring cage is a small travelling crane, carried on overhead runners, for the purpose of loading, &c. The whole machine constitutes one of the most up-to-date and largest machines of its kind in operation in this country, and has already been used with considerable success by Siemens Bros. on the manufacture of the new Anglo-Dutch submarine cable.

CHAPTER XII

HIGH-SPEED STRANDING MACHINES

IN the preceding chapter there was described a set of machines for making electric cables, in which what is known as the "bar" type of stranding machine took a prominent place. These machines are used quite extensively in both the cable and wire rope trades. There is, however, another distinct form of stranding and laying-up machine of great merit, several examples of which are illustrated by the engravings on the following pages. They are made by Thomas Larmuth and Co., Limited, of Todleben Ironworks, Unwin Street, Cross Lane, Salford, Manchester, and are manufactured, under licence, on the Continent by Krupps.

The broad principle employed is the same as that of machines already described, but the Larmuth machine is distinguished by the fact that the main body is not built up of rods and discs bolted together. Instead, it is formed out of a mild steel tube turned up outside, bored through from end to end, and provided with a number of openings or windows to give access to the bobbins. There are three openings round the circumference opposite each bobbin, and the number along the length of the tube naturally depends upon the number of bobbins.

The weight of the tube is carried by a series of rollers mounted in brackets, which can be slid transversely on cross stretcher frames, so that they can be adjusted to share the load evenly without distorting the tube. At each stretcher there is also a hood bracket reaching over the top of the tube and carrying a third roller. Finally, at the back end of the machine there is a mild steel shaft, bolted to the cast-iron end of the tubular body, which runs in a gun-metal bearing.

The bobbin cradles are boat-shaped iron castings, and the trunnions run in standard ball bearings. The front trunnion is bored out with a large hole and bell-mouthed, so as to give a fair lead for the wire coming from the bobbin. The bearings are carried by three-legged brackets, which are riveted to the shell of the tubular body, and can be plainly seen in Fig. 120. The bobbins run on mild steel spindles held in place by means of a spring plate, which drops into a notch in the end of the spindle. It is consequently a simple matter to change the bobbins on reloading. A slight braking effect on the bobbin, to prevent it overrunning, is produced by a cord lapped round a groove in one of its flanges, and tensioned by means of a hooked bolt on the side of the cradle. The smaller sizes of bobbin are made in one piece, from a malleable casting, but the larger sizes are built up with mild steel flanges and a hard wood barrel, with a cast-iron core for the spindle, all held together by rivets running from end to end.

Wire runners or fairleads are riveted inside the tube to guide the wires from the bobbins to the head, and between the runners there are grooved plates for the same purpose.

It will be readily appreciated that the whole arrangement forms a very substantial structure, which can be balanced with nicety, and consequently can be run at a high speed without vibration and with no fear that it will come to pieces. The makers claim, in fact, that these machines can be run at a speed far in excess of any other type, and that they have a correspondingly increased output. It is a common practice to couple Larmuth machines directly with electric motors—as shown in Fig. 120—and

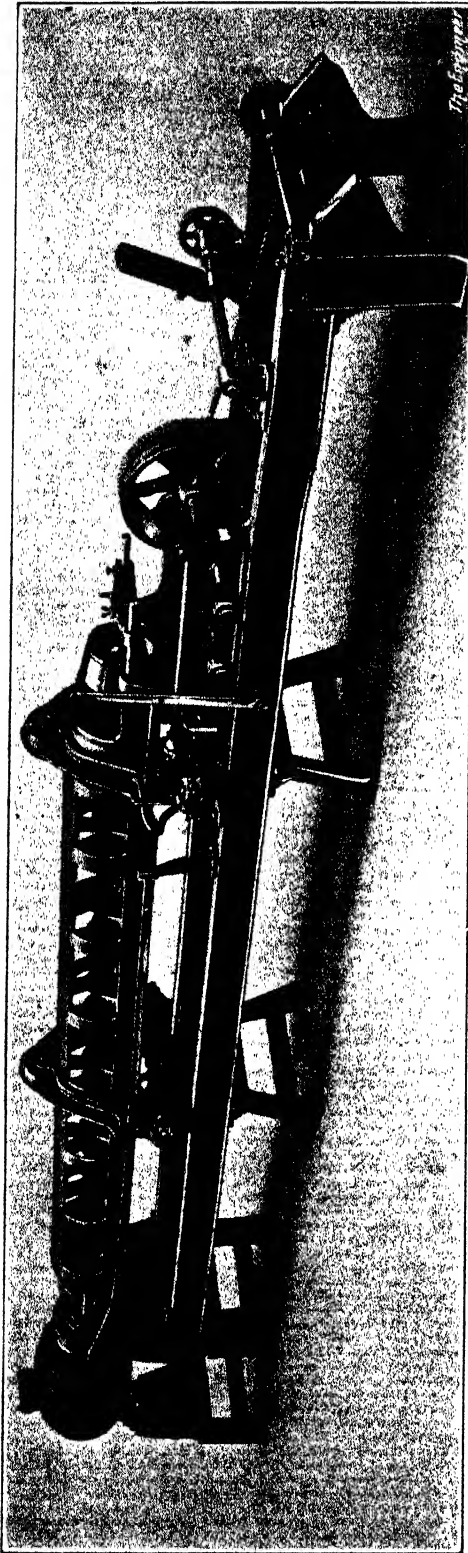

FIG. 120.—SEVEN-BOBBIN 6½-INCH DIAMETER STRANDING MACHINE.

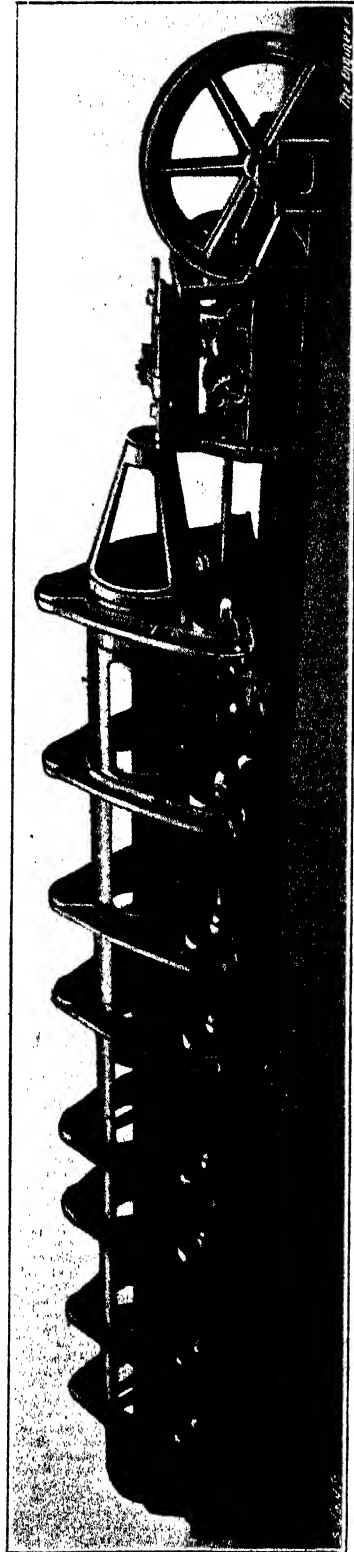

FIG. 121.—EIGHT-BOBBIN 24-INCH DIAMETER CLOSING MACHINE.

HIGH-SPEED STRANDING MACHINES

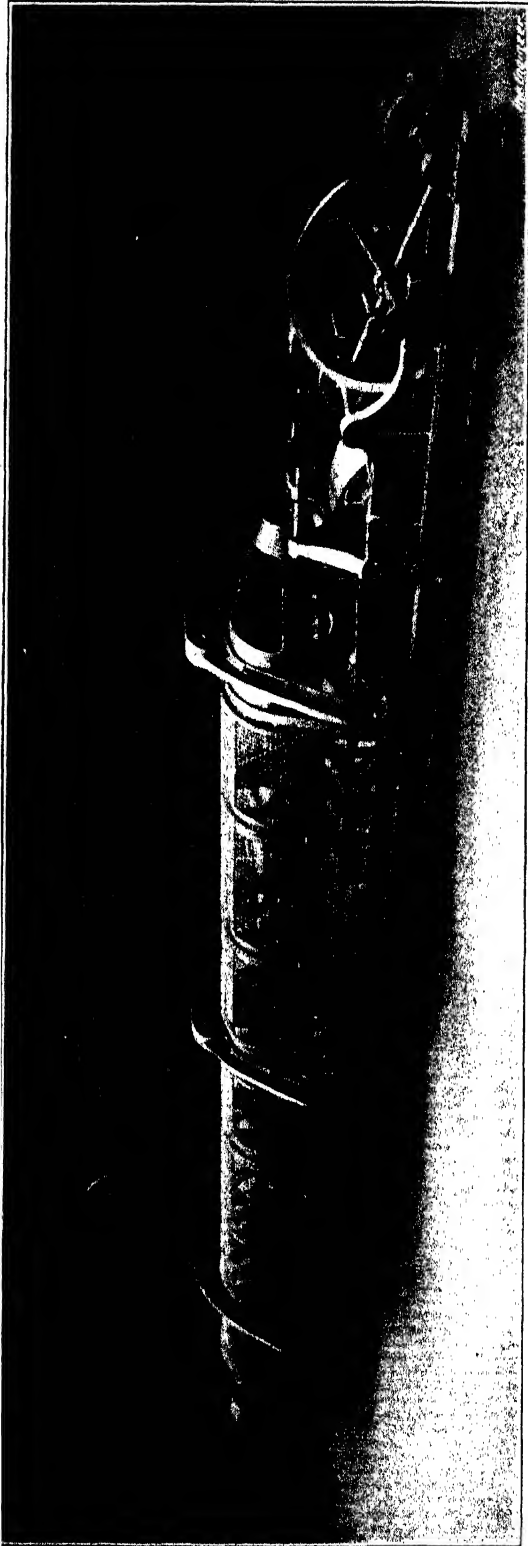
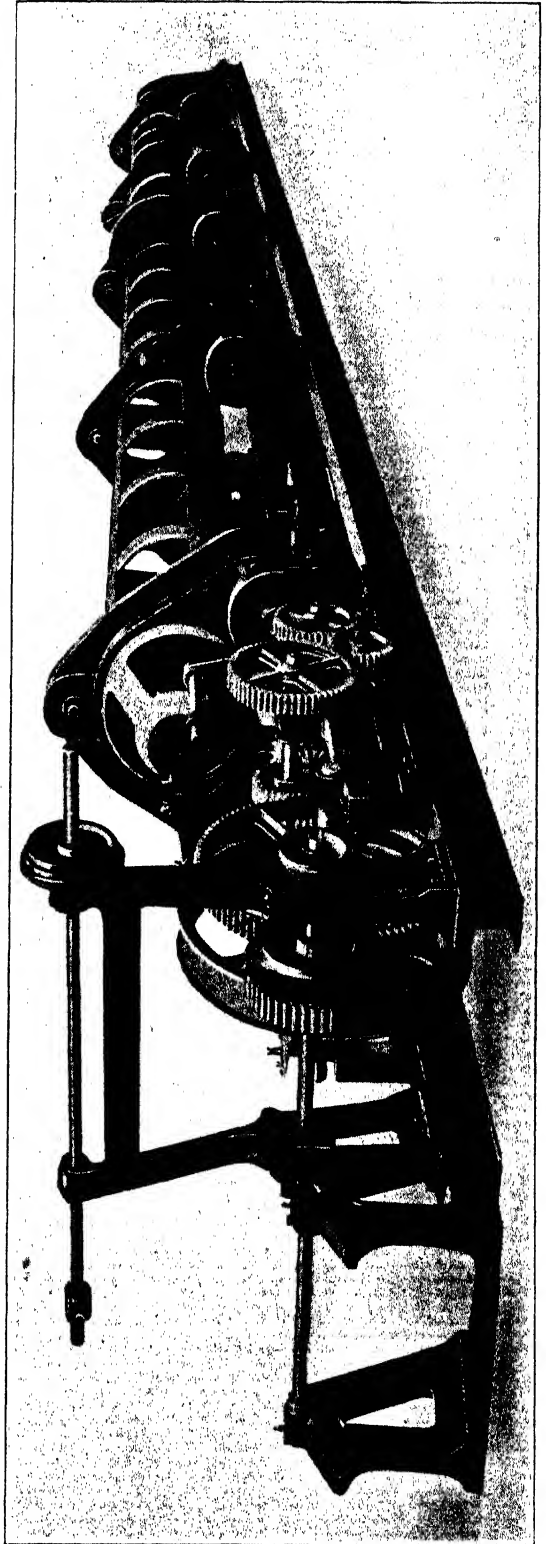

Fig. 122.—SEVEN-BOBBIN STRANDING MACHINE WITH GUARDS AND LIFTING TROLLEY.



BRITISH WIRE-DRAWING AND WIRE-WORKING MACHINERY

run them at speeds well over 1,000 revolutions per minute. Another driving arrangement is to put a belt on the tubular body itself.

In view of this arrangement, it becomes necessary to take the drive for the hauling-off gear from the end shaft of the main body, and a pinion is consequently keyed to the shaft between its two bearings. Inside the pedestal carrying these bearings there is a set of reduction gearing for driving the longitudinal shaft which works the hauling-off capstan. All the gearing is machine-cut and runs in an oil bath. At the capstan end of the machine there is a double set of bevel wheels—see Fig. 121—to allow the machine to be run in either direction, while change wheels provide for various lays of twist.

The lay plate, fixed in the front head of the body, generally has hook-shaped openings for the wires—as shown in Fig. 122—which greatly facilitates stringing up the machine, but sometimes plain bell-mouths are adopted. This illustration also shows a light runway for helping in loading up the bobbins single-handed, and a set of wire guards as an added precaution against flying parts. The brake used to stop

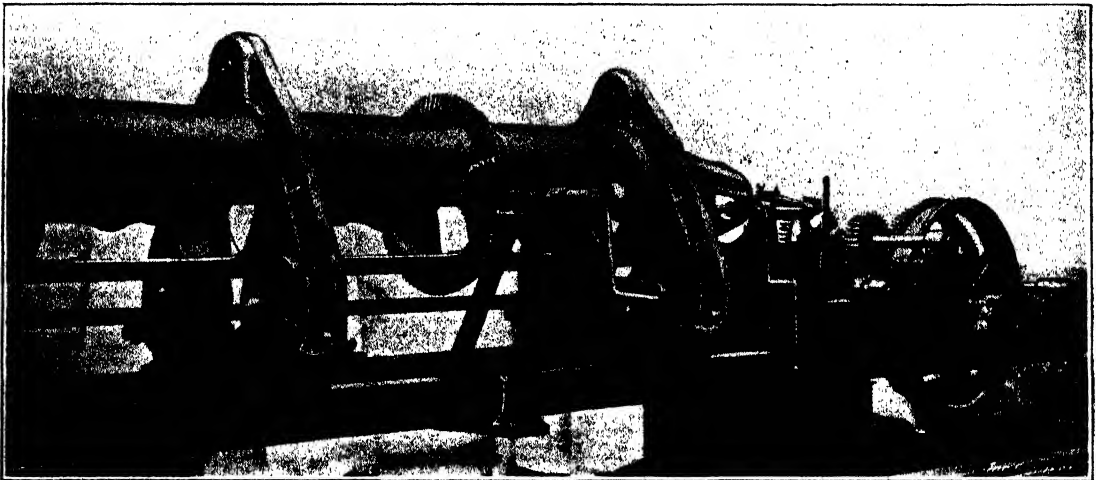

FIG. 124.—HAND-TURNING GEAR.

the machine can also be seen in Fig. 122, just behind the front roller head. It is interconnected with the belt striking gear, so that the brake is put on as the belt is moved to the loose pulley.

The die box for the nips, or dies, is carried by two horizontal spindles fixed in brackets immediately in front of the lay plate, and can be adjusted along the spindles to suit different lengths of lay.

A very simple but effective form of hand turning, or barring, gear for use when loading up the machine is illustrated in Fig. 124, but needs no description; while Fig. 123 represents an eighteen-bobbin stranding machine with the stand for the winding drum arranged alongside the draw-off capstan. In such a case the strand is run over a jockey pulley hung from the roof to guide it from the capstan to the drum.

While the tubular construction is unquestionably the best for moderate-sized bobbins, say, up to 28 in. diameter, it becomes impracticable for larger sizes, and in the case of big laying-up machines, such as that illustrated by Figs. 125 and 126, Messrs. Larmuth adopt the open type of construction. This machine has six

HIGH-SPEED STRANDING MACHINES

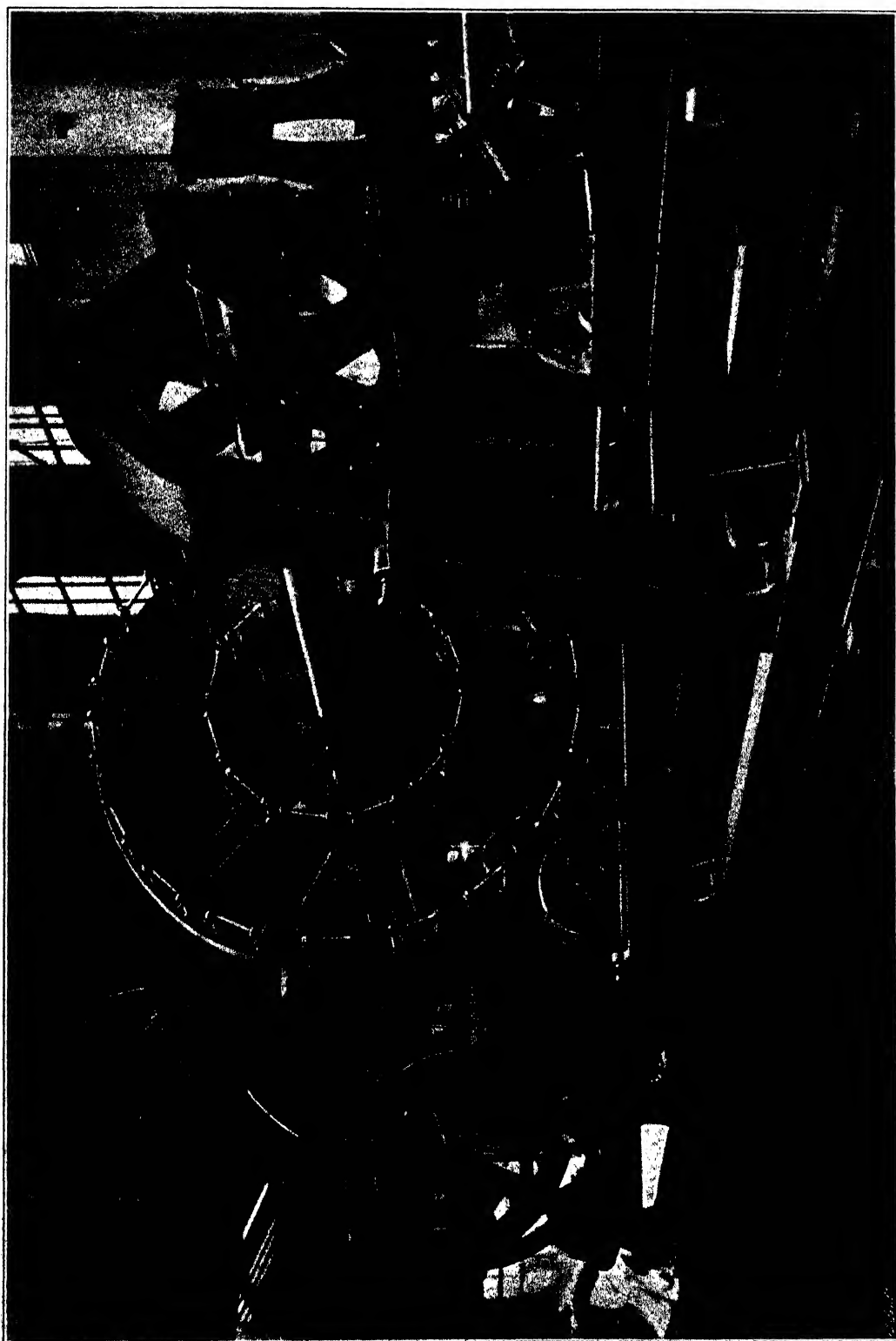

Fig. 125.—SIX-CORE LAYING-UP MACHINE WITH FORTY-EIGHT-BOBBIN PAPER LAPPER AND COPPER TAPING GEAR.

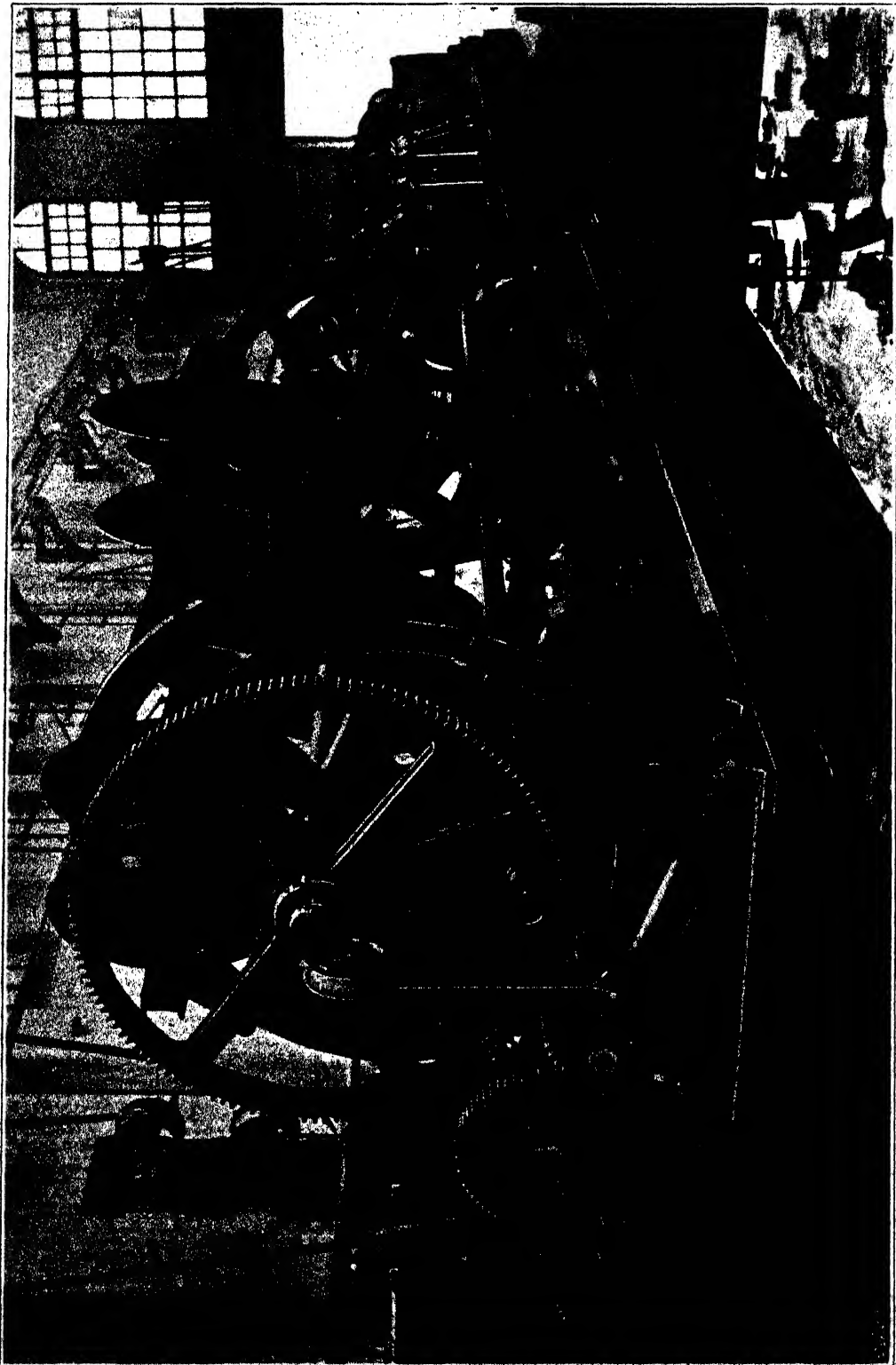

Fig. 126.—SIX-CORE LAYING-UP MACHINE WITH FORTY-EIGHT-BOBBIN PAPER LAPPER AND COPPER TAPING GEAR.

HIGH-SPEED STRANDING MACHINES

48 in. bobbins and works in conjunction with a forty-eight bobbin paper lapper and copper taping gear for making electric cables. It will be noticed that the cradles for the bobbins are built up of rolled steel joists with forged ends, but for slightly smaller bobbins the cradle is generally a single forging. The floating gear and general principle of the machine follow orthodox practice, and need not be enlarged upon here.

CHAPTER XIII

BARBED WIRE MACHINES

Two types of barbed wire are manufactured in this country, and both are made on the same class of machine with only very slight modifications in details. The two types are known as Glidden and Iowa. In the former, a specimen of which is illustrated by Fig. 127, all the barbs are twisted round one of the two strands forming the main line, the other strand being quite plain. In Iowa barbed wire, however, one of the two barb wires is wound round one line wire, while the other barb envelops the two line wires together. The object of the Iowa arrangement is, of course, to prevent the barbs from sliding along the line wire after manufacture, and thus spoiling the regularity of the spacing. It is claimed by some manufacturers, however, that it is possible so to adjust the machinery that the barb wires are so tightly wound round the single strand, Glidden fashion, that they will not slip appreciably. And if this desirable

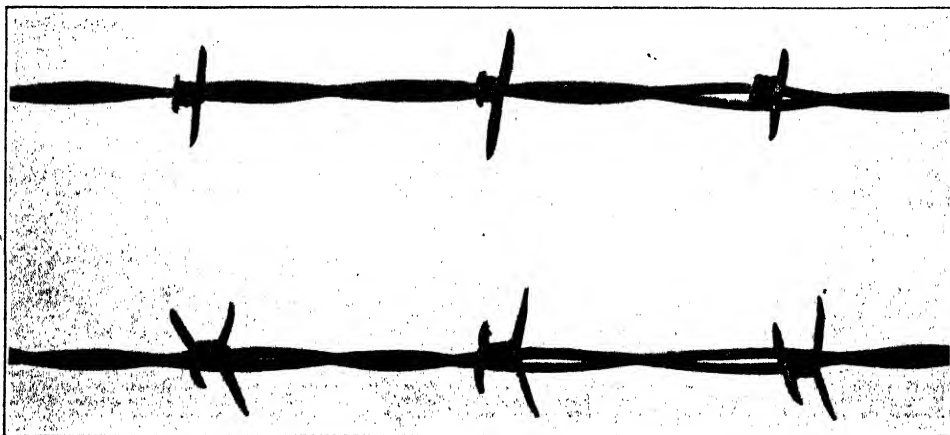

FIG. 127.—GLIDDEN BARBED FENCING WIRE.

feature can be attained, it is advantageous, as the setting up of the machine is simplified, while the amount of wire required for making the two pairs of barbs is consumed at the same rate and renewals of supplies to the machine can be made simultaneously.

Barbed wire is generally made of ordinary mild steel wire, galvanised, but there is a growing tendency to adopt high-tensile steel, especially for export trade, as the same strength can be secured with a reduced weight and transport charges are correspondingly reduced. At the same time, whilst the cost of the wire by weight is slightly increased, the cost by length is reduced. There is, however, still a certain amount of trade done in barbed wire by weight, and then not only is mild steel used, but the barbs are made extra long, so as to add to the weight without appreciably increasing the cost of manufacture.

The two types of barb machine, already referred to, are illustrated by the engraving, Fig. 128, and the drawing, Fig. 131, while some details of the former type, which are more or less applicable to the latter, are represented in the sketches of Fig. 129.

BARBED WIRE MACHINES

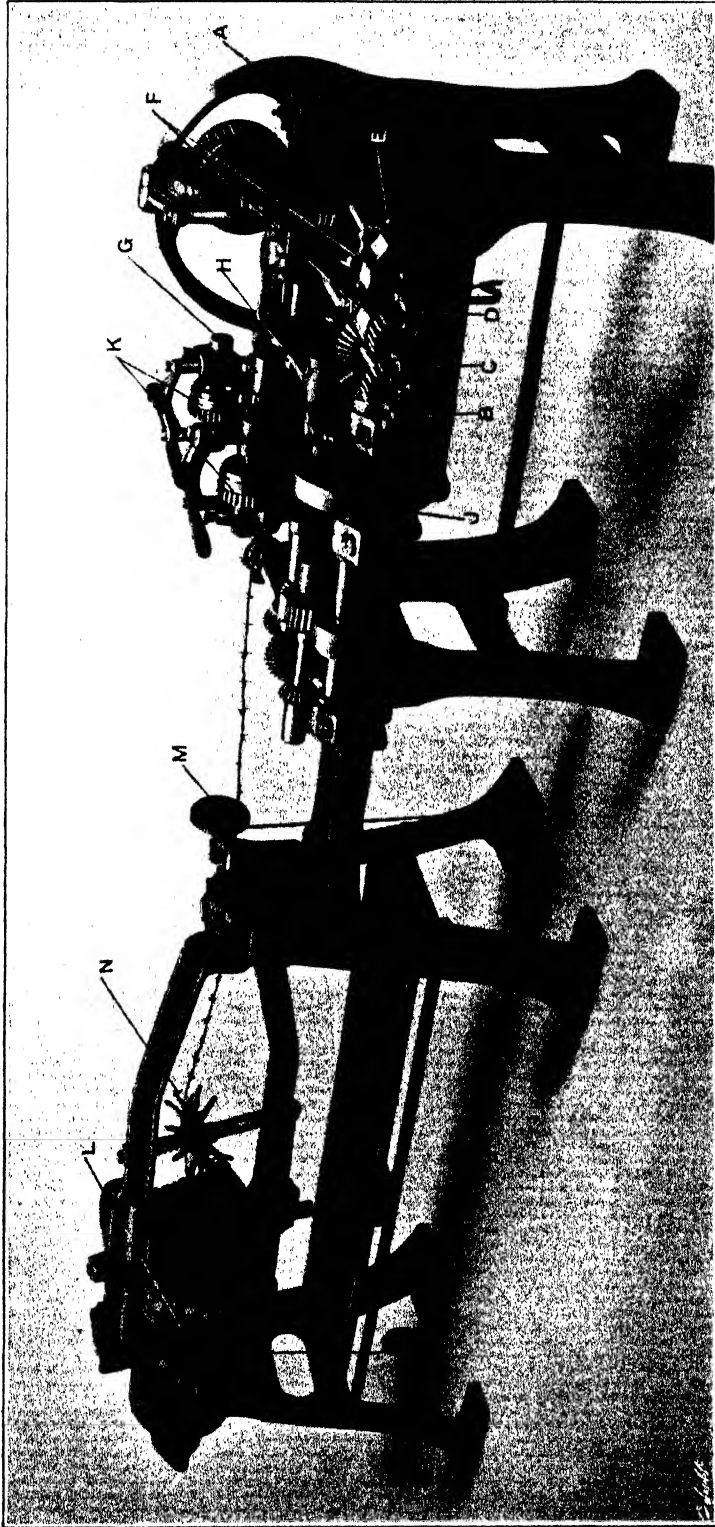

FIG. 128.—BARBED WIRE MACHINE—J. HETHERINGTON AND SONS.

BRITISH WIRE-DRAWING AND WIRE-WORKING MACHINERY

The machine shown in Fig. 128 is made by John Hetherington and Sons, of Manchester, and is distinct from that illustrated by Fig. 131 in that the feed of the two line wires is defined positively at the inlet end of the machine.

It may be as well here to point out that in either case the wire is fed into the machine off four swifts. Two stand at the back and supply the two main line wires, which generally range from No. 10 to No. 14 in gauge, while two other swifts, which stand one on either side of the machine, provide the wire for the barbs. This wire is of much the same gauge as the line wires. The barb wires are sometimes known as "cross wires."

On reference to Fig. 128, it will be seen that there are two leading-in tubes A A for the line wires, and immediately beyond there is a pair of feed rolls geared together.

These rolls are pressed together by springs, and the wires are gripped between their plain faces. It is necessary to give the wires an intermittent feed, as they must be stopped while the barbs are being applied, and this intermittent motion is provided by the gearing in the foreground of the illustration.

The shaft B is driven continuously by the main belt pulley seen in the background. A wheel on this shaft meshes with another on the intermediate shaft C, which also runs continuously and drives the feed roll shaft D by means of a tappet and the catch plate E. This catch plate works in conjunction with the motion wheels F F, and both are so formed that the wires are fed forward to the extent of the pitch of the barbs, and then held stationary for a sufficient length of time for the barbs to be formed. The shape of the several wheels naturally depends on the pitch and the length of the barbs, and

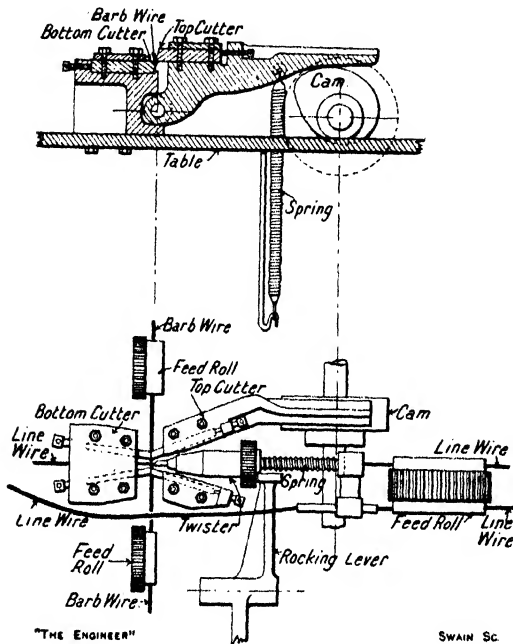

FIG. 129.

different forms can be put in place, to suit the immediate requirements, quite readily.

Of the two line wires leaving the feed rolls, that in the background is led through the hollow twister G, also shown in the lower sketch of Fig. 129, while the other wire is led through a second guide tube to beyond the twister when Glidden wire is being made. (The arrangement for making Iowa wire will be described later.)

The twister serves the purpose of wrapping the two barb wires round the line wire, and is rotated by the rocking lever H—see Figs. 128 and 129. A toothed quadrant on the end of this lever gears with a pinion on a small countershaft, which also carries a gear wheel that meshes with a pinion on the twister. The rocking motion is imparted to the lever by means of the cam J on a side shaft, which is driven by mitre wheels off the first motion shaft B.

The barb wires are fed into the machine by the two pairs of rolls K K, which are driven intermittently off the side shaft. On this shaft there is a partially toothed wheel, the plain part of whose circumference is to the front in the engraving, Fig. 128. This wheel engages with another partially toothed wheel on a countershaft, and a train of gears transmits the intermittent motion of the countershaft to the feed rolls. There

BARBED WIRE MACHINES

are, of course, tappets on the side and countershafts to ensure that the teeth of their wheels will re-engage at the proper times. The length of wire fed forward for each barb is generally from 2 in. to $2\frac{1}{2}$ in., but the amount can naturally be varied by altering the feed gear.

The operation of the machine can best be followed with the aid of the diagram Fig. 130, which is an imaginary view facing the camera which took the view reproduced in Fig. 128, with the result that the several parts are of the opposite hand to Figs. 128 and 129.

Fig. 130 shows the line wire emerging from the centre of the hollow twister, and the two barb wires fed forward. At this moment all the feed rolls stop, and the wires are held fast. The rocking arm H makes a stroke, and gives the twister several turns, so that the two steps on its end engage the barb wires and twist them round the line wire. As the twister coils up the barb wires, it must retire along the line wire, as the first turn of the coil cannot go forward. This backward movement is accommodated by driving the twister through a long-toothed pinion and allowing it to slide back against the pressure of a spring, which is plainly shown in Fig. 129.

The next operation is to cut off the completed barbs from the following wire, and this is done by the cutters shown in the upper part of Fig. 129. The action of the cutters is fairly obvious from the sketch, but it should be pointed out that the cut is taken diagonally, at a fine angle across the wire, so as to provide points on both the completed barbs, and the following ones made at the next operation. At the time that the cut-off takes place it is important that the two first barbs should be pointing up and down, as

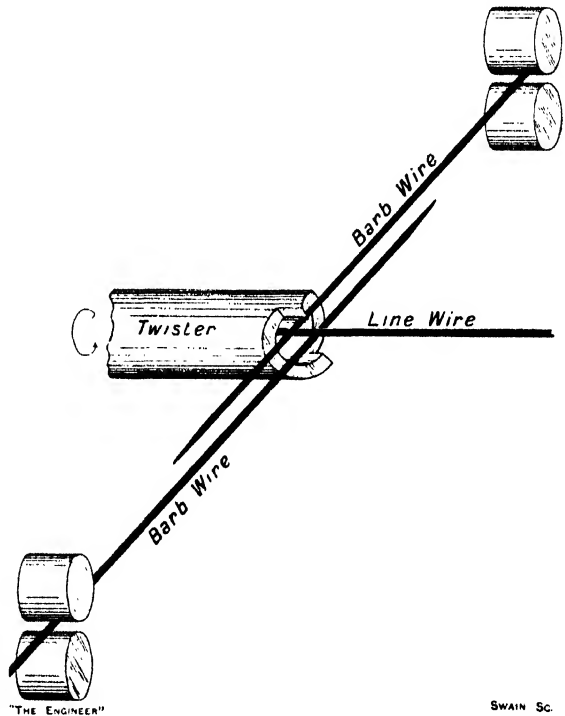

FIG. 130.

otherwise they would be in the way of the horizontal cutters, and it is one of the delicate jobs in adjusting a barb machine to get the twister to stop in the proper position to produce this effect. As soon as the barbs have been cut off, the feed rolls start again, and the whole sequence of operations is repeated, the twister being returned to its working position in the interval.

The speed at which the barbed wire is made naturally depends upon the pitch of the barbs, as the line wires have to stand still while each pair of barbs is being made; but some idea of the rate of progress may be gathered from the fact that the feed rolls normally deliver the wire at about 150 ft. a minute, although during times of pressure this speed has been almost doubled.

After the barbs have been wrapped round one of the line wires, the other line wire must be twisted together with it, and this is effected by the take-off gear.

On the left of the barbing machine in Fig. 128, it will be seen, there is a cradle which carries a winder for the finished wire. This cradle is rotated by its own separate belt

BRITISH WIRE-DRAWING AND WIRE-WORKING MACHINERY

drive, and twists the two line wires together as they are drawn away from the barbing machine.

The finished wire is wound on to a rough wooden bobbin, which is mounted in the rotating cradle, and this bobbin is, in turn, rotated on its own axis by a set of gearing working in conjunction with a brake at the extreme end of the machine. This brake controls the mitre wheel L—see Fig. 128—and by retarding it, as compared with the rotation of the cradle, determines the speed of the bobbin, so that the take-off can be adjusted to agree with the rate of delivery from the barbing machine. The tension on the brake is adjusted by means of the ratchet wheel M, with which it is connected by means of the wire shown running along the floor.

In the centre of the cradle there is a star wheel N, which is mounted on a right and left-handed screw and serves to lay the wire across the width of the bobbin. The spindle on which the bobbin works is, by the way, so arranged that it can be quickly slipped out for the removal of a filled bobbin and the installation of a new, empty, one.

So far the whole process has been followed through only in connection with the production of Glidden barbed wire, but the alterations necessary for making Iowa wire are not extensive, except that Iowa wire is always wound left-handed, as against right-hand for Glidden wire. This latter change necessitates the reversal of the rotation of the taking-off cradle, and as a consequence involves a slight modification of the gearing.

The other change necessary for making Iowa wire—that in which one of the barb wires is wrapped round both line wires—is to lead both the line wires through the twister.

The twister is provided with two separate passages for the two line wires, and the driving mechanism is so timed that when the barb wires are fed forward by their rolls the line wires are vertically above one another. Then one barb wire is directed so that it goes between the two line wires, while the other goes outside both. The twisting and cutting actions are the same as those already described.

These machines are normally rated to produce 20 cwt. of barbed wire per ten hours' shift when making 6 in. pitch Glidden wire, and require somewhere about 6 to 6½ horse-power. The overall dimensions of the machine itself are 13 ft. 6 in. by 4 ft., but, allowing space for the accommodation of the wire swifts, they require some 20 ft. by 16 ft. of floor space. The bobbins are generally arranged to hold 1 cwt. of wire.

The type of barb machine illustrated by Fig. 131 is that adopted by Richard Johnson and Nephew, referred to in a previous chapter, and is differentiated from that just described in two essential features. One is the arrangement of the winding cradle beneath the barbing gear, so that the overall length of the machine is approximately halved, while the other is the method employed for feeding the line wires. The twisting, cutting-off and barb wire feed mechanisms are much the same, except that the last mentioned is operated by a crank gear in place of the partially toothed wheels shown in Fig. 128. The line wire feed scheme is, however, totally different.

The line wires are taken from their swifts over the guide pulleys A A, round which they make a complete turn, so as to produce a slight braking effect, and then go directly to the twister. (It should be noticed that one of the pulleys has twin grooves for use when Iowa wire is being made.)

After passing through the barbing head, the wires are led over the star pulleys B and C, and then double back to the winding cradle, which operates in very much the same manner as that already described.

The star wheel B is mounted on the bottom end of a rocking lever, which is driven

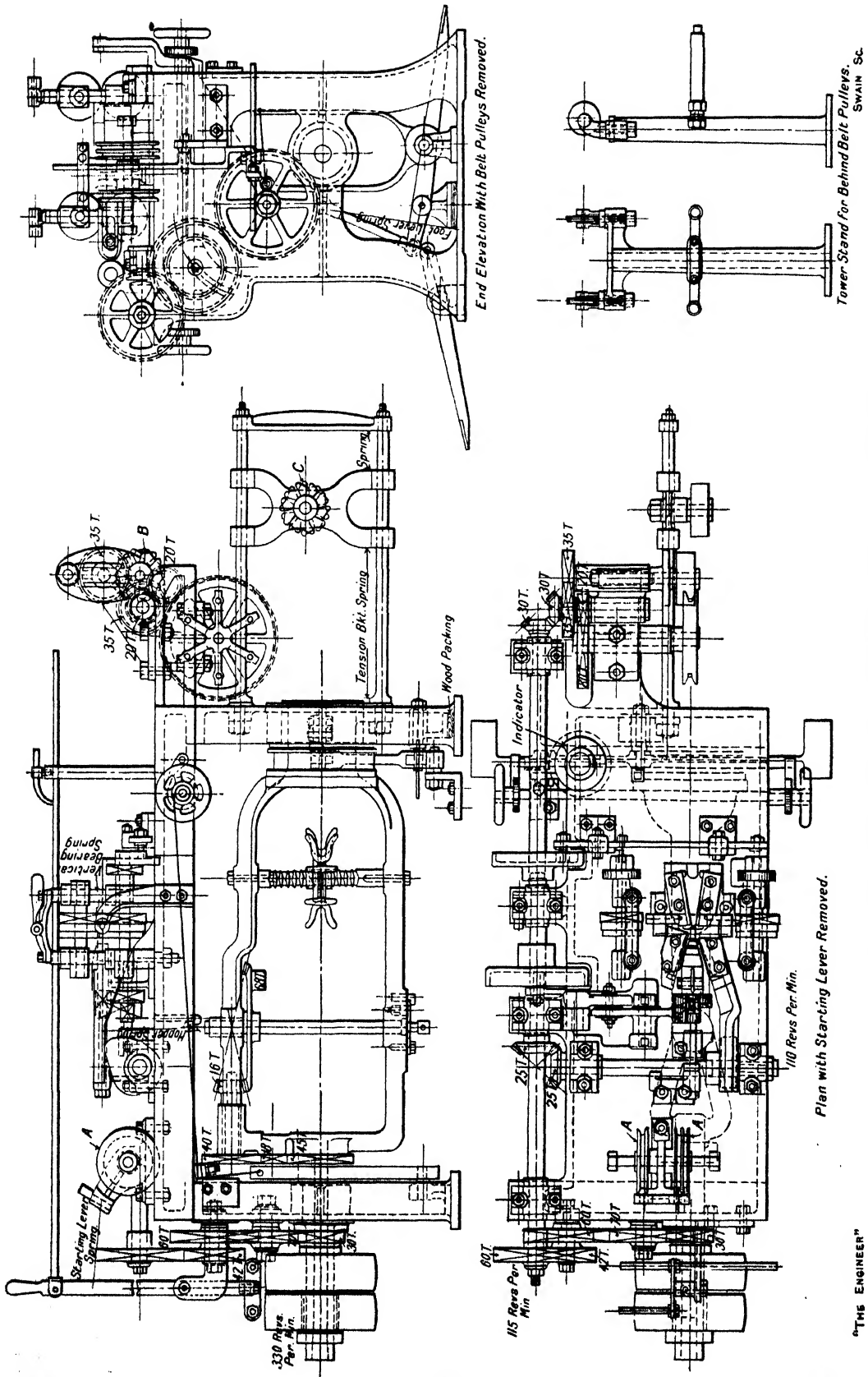

FIG. 131.—BARBED-WIRE MACHINE—RICHARD JOHNSON AND NEPHEW.

"THE ENGINEER"

BRITISH WIRE-DRAWING AND WIRE-WORKING MACHINERY

through gearing, from the side shaft of the machine, and can be given a variable length of stroke by means of a crank pin working in a slot. The speed of the lever can also be altered by changing the gear wheels.

The object of arranging the wheel B on the rocking lever is, of course, to provide the intermittent feed of the line wires necessary for giving time for the barbs to be twisted. The wires are constantly drawn forward by the taking-off gear, but during such time as the wheel B is moving to the left, its travel counteracts the forward pull of the bobbin, and the wires are not drawn through the barbing head. When, however, the wheel B moves to the right, the wires are rapidly pulled forward as the speed becomes the sum of the speeds of the pulley and the bobbin—allowance being made, of course, for the angularity of approach of the wire to the pulley. The pulley C, it will be noticed, is mounted on a sliding frame, and is controlled by springs so as to keep a reasonable tension on the wires.

These machines are generally run at a speed which produces about 110 pairs of barbs a minute, and the length made in a given time naturally depends upon the pitch of the barbs.

CHAPTER XIV

NAIL AND RIVET MAKING MACHINES

WHAT is known as the Birmingham type of nail-making machine is probably the most extensively used form in this country, although there is a tendency towards the adoption of the American type. This book is not, however, intended to embrace foreign machinery, and it will be sufficient to say of the American nail-making machine that it employs steady pressure instead of a blow for forming the head.

Wire nail machines are made principally in the Birmingham district by a number of firms, but they are all so very much alike that it is unnecessary to deal with more than one, and that taken for illustrative purposes in this article is by Wm. Grice and Sons, Limited, of Fazeley-street, Birmingham.

The general appearance of the machine can be gathered from Fig. 132, while Fig. 133 is a general arrangement. It will be noticed that these machines are very substantially built, which is necessary to withstand the hard service they are commonly subjected to, but otherwise they possess no remarkable constructional peculiarities, so we will proceed directly to the method of operation.

The wire is drawn into the machine through a set of straightening rolls, and is fed forward by a grip A—see Fig. 133—which is reciprocated by the rocking lever B and crank C. The throw of the crank can obviously be set according to the length of nail to be made. The grip is a simple trigger, kept in contact with the wire by a light spring, and holds the wire tightly on the forward stroke. When moving backwards, however, it slides over the wire, which is then held by the gripping dies, and consequently cannot return even if the feed grip is somewhat stiff.

The gripping dies have to hold the stock very firmly, and are aided in this by projections which form the familiar serrations in the nail shank, just below the head. The grip is made in a vertical direction, with the lower die stationary. The upper die is pulled down by a powerful set of levers D and E, actuated by a cam just inside the feed crank disc, and is raised on the return, or opening, stroke by a helical spring. While the wire is held by these dies, the head is formed by a single blow of the heading die, which is propelled forward by the laminated bow spring seen at the rear of the machine.

The heading die is fixed in the end of the ram F, which slides in guides over the top of the main shaft. On the shaft there is a single beaked cam, which engages a projection on the ram, forcing it back and compressing the spring. As soon as the cam overrides the projection, the ram is free, and is shot forward violently with such force that a single blow of the die is sufficient to form the nail head. The noise made, not only by the actual blow, but also by the spring as it is suddenly compressed, is so great that it is quite futile to attempt conversation in a shop where there is a battery of nail-making machines at work.

After the head has been formed, the gripping dies open and the wire is pushed forward by the next feed movement. It then becomes necessary to form the point of the nail, and cut it off from the stock. The two operations are performed simultaneously by a pair of dies moving in a horizontal direction. These dies are worked by the two levers G G, and corresponding cams on the main shaft. The dies produce

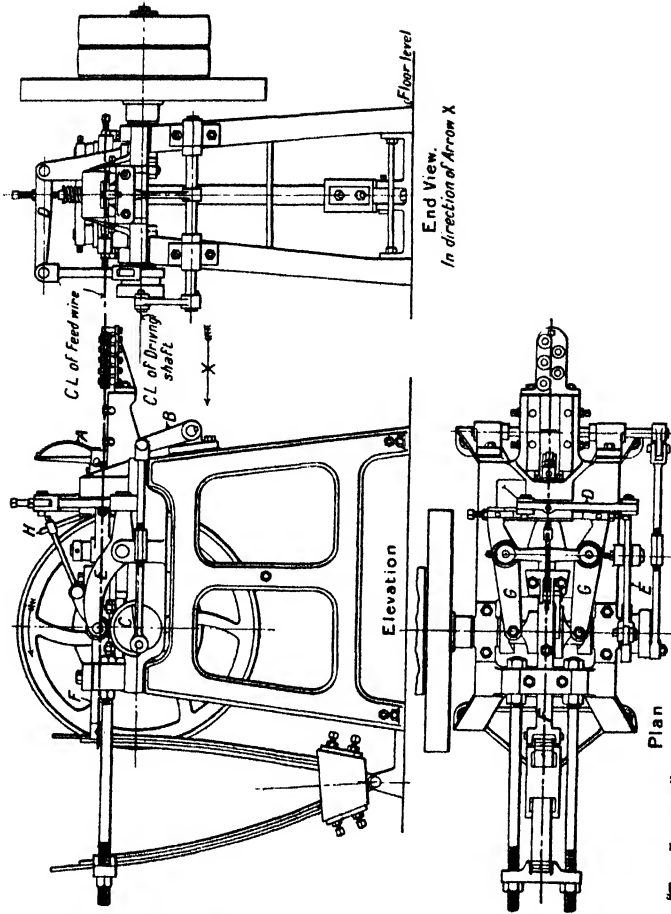
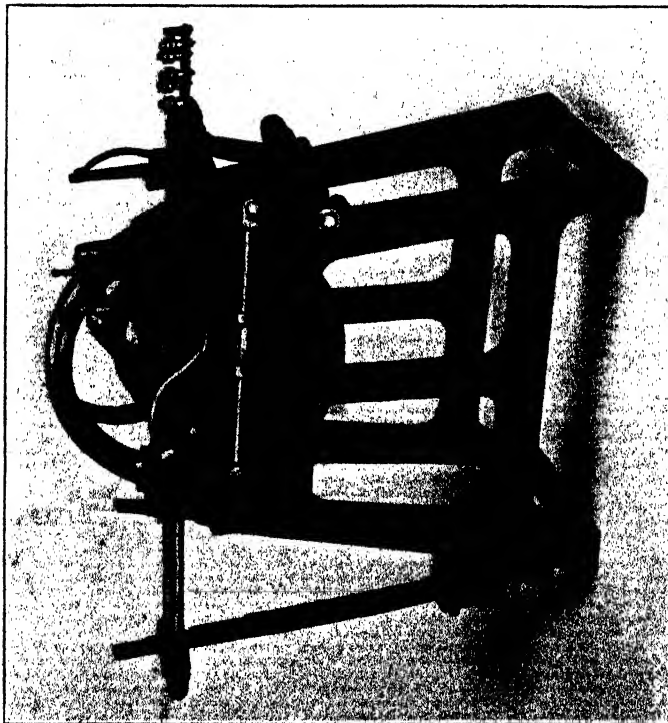

"THE ENGINEER"

FIGS. 132 AND 133.—WIRE-NAIL-MAKING MACHINE—W. GRICE.

SWAIN SC

NAIL AND RIVET MAKING MACHINES

a squeezing, rather than a cutting, action, and are formed by making three nicks in the end of a piece of tool steel with a "three-square" file. The faces of a pair of dies are well shown in the cut, Fig. 134, but it should be pointed out that, for illustrative purposes, the two dies are shown approaching one another at an angle, whereas they are in line when at work.

The dies squeeze out the metal in two triangular fins, or "nibs," as they are called in the trade, with deep nicks on all sides, which nearly sever the metal. The dies cannot, of course, be made to cut right through the wire, as they would then come in contact with one another and be destroyed; but by careful adjustment the nicks are made so deep that the nail is ready to fall off the stock after it has been pointed. In order to make sure, however, that the nail will fall clear before the next stroke of the heading die, a striker H comes down from above and knocks it into a receptacle below.

An important point in connection with the cutting of the dies is that they should be so formed that the completed nail will carry away the nibs with it, and not leave them on the stock, as the stock must be left with a clean square end, or the next head will be deformed. It is also essential that the point should be symmetrical, or it will not go straight when it is driven by a hammer.

The nails are subsequently put in tumbling barrels to knock off the nibs, and to give them a good polish. The nibs, by the way, have a high market value in the steel trade as scrap, on account of the dense manner in which they pack together.

Machines of the type just described run at a really remarkable speed, considering the extent of the deformation of metal which the production of each nail involves, and produce anything from 90 up to 300 pieces per minute. That is to say, nails from 5 in. to 6 in. long can be made from No. 4 gauge wire at a rate of from 90 to 100 per minute, while the output of small nails of, say, 1 in. length, by No. 14 gauge, is at least 300 per minute. The power required even by the largest machine is only some 2 horse-power.

In some factories, such as Rylands, at Warrington, the better-class nails are all sorted over by hand to eliminate any that may be defective, and this sorting is carried out by boys as the nails slide down a flat steel plate vibrated by a power-driven hammer.

The twisted or screw nails, which are sometimes used for such purposes as fastening packing cases, are made in the manner just described, but the wire is given its spiral groove before being sent to the nail-making machine. Ordinary round wire is drawn through a rotating spindle, and either one or the other of two systems is employed to make the spiral groove. In one there are three or four balls—the same as are used in ball bearings—mounted in the spindle, and they deform the wire, as it is forcibly drawn through, into a spiral with a pitch depending on the relation between the speed of draw and the speed of rotation of the spindle. In the other system a more or less sharp groove is cut in the wire by a set of disc cutters, mounted at an angle with the axis of rotation of the spindle. If proper precautions are taken to eliminate undue friction in the revolving parts, the angularity of the cutters will produce the necessary rotation of the spindle without it being necessary to provide it with an individual drive.

In making rivets from wire stock, a different process is adopted, as compared with the formation of pointed nails, and Fig. 135 illustrates the essential features of the machine employed.

The primary peculiarities of the machine lie in the facts that each length of wire



FIG. 134.—NAIL-POINTING DIES.

BRITISH WIRE-DRAWING AND WIRE-WORKING MACHINERY

is cut off from the stock before it is headed, while the head is formed by steady pressure instead of by a sudden blow.

On reference to the drawing, Fig. 135, it will be seen that the line of the feed does not coincide with the axis of the heading tools. (It is, by the way, hardly necessary to enlarge upon the mechanism of the feed gear, except to point out that by lifting the notched lever A off its pin on the rocking lever B the feed is stopped.) The reason for this lack of alignment is the fact that the rivet must be left with a perfectly smooth shank, and consequently cannot be gripped, sideways, sufficiently firmly to withstand the heading pressure. In other words, the end of each blank must bear against a solid abutment during the heading operation.

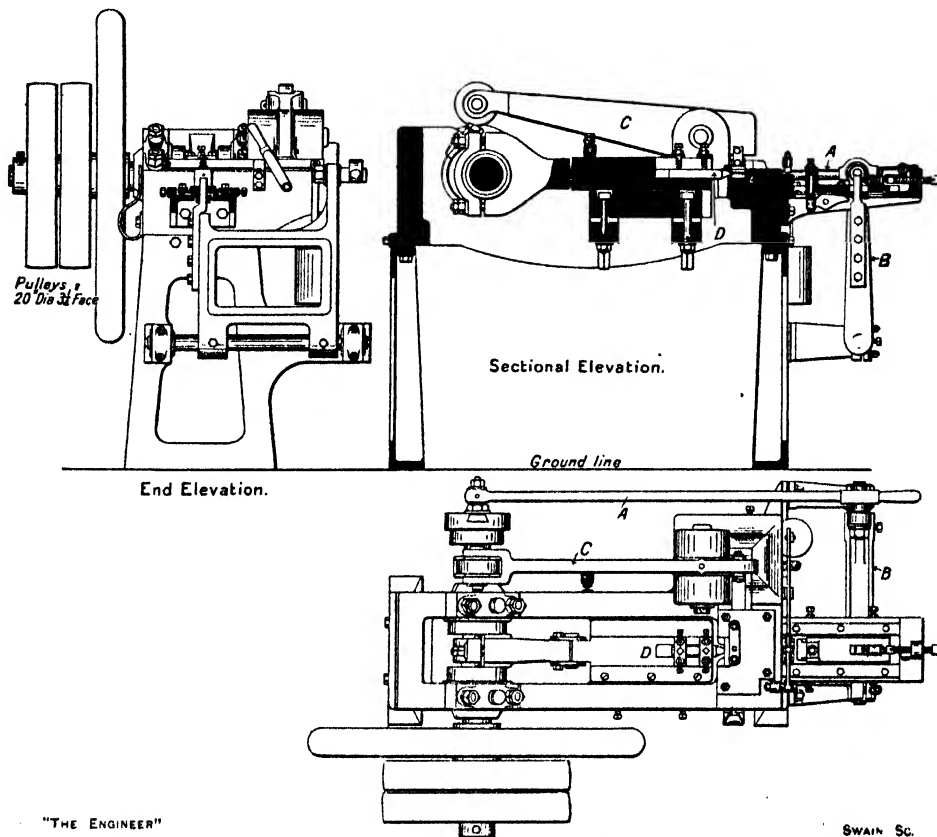

FIG. 135.—RIVET-MAKING MACHINE.

The wire consequently is fed forward through a tunnel to the extent necessary to produce a rivet, and is projected between two dies held slightly apart. The dies are then closed together, and moved across the mouth of the tunnel, against the pressure of a spring, so that the wire is sheared off against the edge of the tunnel mouth and is carried bodily sideways until it is in line with the heading tools. In this position the butt end of the blank bears against the plain face of the tunnel die, and is consequently well supported against the heading pressure.

The gripping and transverse movement of the dies is generally effected by a wedge-shaped piece, which is pressed forward by a lever, such as C, operated by a cam on the main driving shaft. The heading die D is mounted in a ram which is worked by an eccentric on the main shaft.

NAIL AND RIVET MAKING MACHINES

When the rivet has been headed, the gripping dies move back to the original position, then open, and the oncoming stock pushes the rivet out, to fall down into a container below. It will be appreciated that when the rivet is ejected from the gripping dies it is out of line with the heading tools, and consequently has more opportunity to fall clear before the next stroke of the ram takes place than is the case with a nail-making machine, where all the operations are performed in one line. As a consequence, it is not always necessary to have a knock-out to throw the completed rivets out of the machine, but with really high-speed work a mechanical knock-out becomes necessary.

A common rate of working for these machines, when producing rivets of $\frac{3}{8}$ in. diameter and up to $1\frac{1}{2}$ in. long, is 95 pieces per minute. Larger machines, which are generally gear-driven, will head 40 $\frac{1}{2}$ -in. rivets a minute. These large machines almost always have cast steel frames, to withstand the heavy stresses involved in the heading operation, and some idea of their substantialness may be gathered from the fact that their weight may be as much as 8 or 9 tons.

CHAPTER XV

PIN-MAKING MACHINES

It is said that the wire-drawing industry was first introduced into this country on account of the demand for pins at the court of Queen Elizabeth, but the process of making the pins was then totally dissimilar from the system now universally adopted. In the early days pins were made by hand, individually, and the heads were formed by little rings of wire squeezed and soldered on to the stem. The modern system is

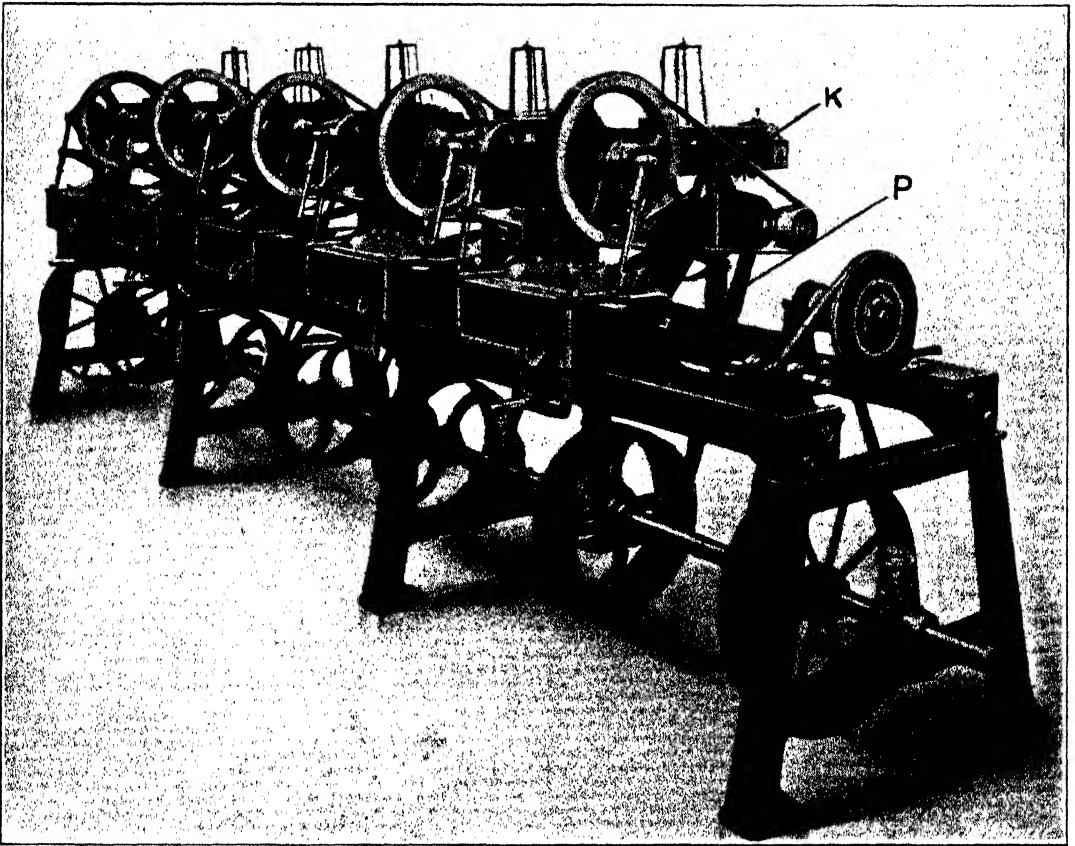

FIG. 136.—BATTERY OF FIVE PIN-MAKING MACHINES—E. WHITE.

to upset the metal to form the head, but a special process has to be adopted as the head is so large, by comparison with the stem, that it could not be formed at one blow, as is the case with nails.

As would only be expected, a pin machine is a comparatively small affair, a fact which can be judged by a reference to Fig. 136. This engraving shows five machines, by Mr. Edward White, of Redditch, and it will be seen that the whole set occupies only a few square yards of floor space. The output of pins is, however, really remarkable

PIN-MAKING MACHINES

when account is taken of the number of movements necessary for the production of each pin. The set of machines illustrated is capable of turning out 45,000 pins an hour, and was made for a factory in South America.

The operation of the machine can best be followed with the aid of the sketch, Fig. 137, from which it can be seen that the stock of wire is carried on a swift at the back, and is straightened by a set of pegs—the length of wire required by each pin is so short that pegs will make it quite straight enough without the added complication of a spinner. The wire is led through a little tunnel die, at the outlet end of which there is a cutting-off knife operated by the lever A. It is necessary that the wire

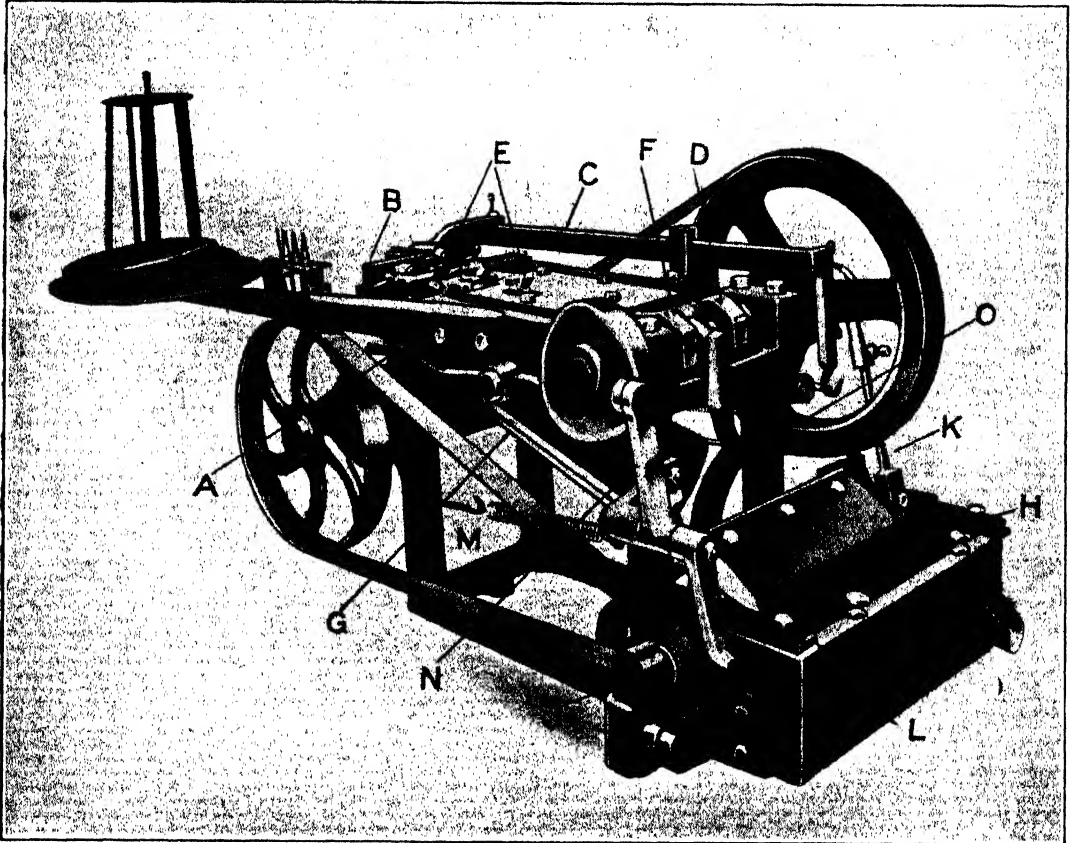

FIG. 137.—AUTOMATIC PIN-MAKING MACHINE—E. WHITE.

should be cut off very neatly and without a burr, as any irregularity in its end would spoil the shape of the coming head.

The feed of the wire is effected by the grips B, which are opened and closed by the side lever C and a cam on the main shaft. The reason for putting this lever right over at one side is to leave the top of the machine accessible. The feeding movement is given by a second cam. It will be noticed that the end of the lever C is bent down and engages a spring to return the grips on the back stroke. The feed has to be effected in three separate stages. First, the wire is brought forward so that it extends about $\frac{1}{8}$ in. beyond the front of a pair of gripping dies. Then, as the head is formed, the wire is again fed forward $\frac{3}{2}$ in. in two separate steps, while the other heading blows are struck. These secondary feeds, which are produced by very fine steps on the

BRITISH WIRE-DRAWING AND WIRE-WORKING MACHINERY

cam, are effected so quickly that they cannot be observed by the eye when the machine is running. They can, however, be felt with a finger on the feed slide and are quite definite.

The gripping dies just mentioned are operated by the cam D, which moves a ram running beneath the top cover of the machine. This ram terminates in a wedge-shaped piece, which, when driven forward, closes the dies. The dies, by the way, have to be made very carefully, as if they produce any flats on the wire the pin point cannot be formed, while the grip must be sufficiently tight to withstand the heading blows. Incidentally the mechanism has to be made and adjusted very accurately as the gripping dies have to be opened three times for the formation of each pin head—twice while the secondary feeds for heading take place and again when the head is complete. In this connection it should be pointed out that all the cams are keyed rigidly on to the shaft, so that when once set they cannot be moved. This rigid attachment naturally involves very careful workmanship in erection.

The three blows for setting up the head of the pin are all struck by one die, the adjusting screws for which can be seen in Fig. 137 at E, while the working cam is marked F.

The headed pins fall down between the gripping dies when they open for the third time, and are caught in a shoot G below. This shoot has a very narrow slot running down the centre, and the pins hang in this slot by their heads. They gravitate downwards, and are guided round a gentle curve at the bottom into a transverse slot H, running across the front of the machine. It is a peculiar thing about the working of these machines that when they are first started up the pins are rather sluggish in going down the shoot, but after running a short time the edges of the slot become glazed over with a thin film of metal from the pin wire, and then the pins descend the shoot quite smoothly.

The pins are pointed as they traverse the groove H, in the following manner:—

Below the table there is a long grinding mill, supported at one end in the bearing J and driven at a speed of some 4,000 revolutions per minute. In the case of brass pins, the mill is formed as a number of hard steel sleeves, cut with file teeth, and held on to the spindle by bands. This construction is adopted as it simplifies the renewal of the first sections of the mill, which wear blunt more rapidly than the others. For steel wire pins a carborundum or emery grinding mill is used.

If the pins were merely fed across the face of this mill, they would receive a hollow ground point, which would not be stiff enough for service. They must have an ogival point, and for this reason the end of the mill is made to travel through an appropriate path. The mechanism for performing this function is best shown in Fig. 136, in which it will be seen that there is a crank pin on the end of the main driving shaft, and that this crank operates a connecting-rod K—also shown in Fig. 137. The lower end of this connecting-rod carries one of the bearings for the mill, and is pressed against a little stationary former. The former is so shaped that as the connecting-rod reciprocates the bearing, the working face of the mill traces out the desired shape of point. It will be obvious that the two bearings have to be coned to accommodate the movement of the mill, and that the movement will be angular, gradually increasing with the distance from the driving end. In this way the beginning of the mill is made to rough out the points, while the end gives them their final form.

The arrangements for feeding the pins along the slot H, from left to right, are very ingenious, and are shown in Fig. 137. There is a bar running across the machine under the table, the end of which can be seen at L. This bar is in front of the pins hanging in the groove H, and is pulled up against them by the spring M. The bar is

PIN-MAKING MACHINES

reciprocated by the cam seen on the end of the main shaft, through the rocking lever N, and consequently rolls the pins backwards and forwards across the face of the mill so that the point is ground truly circular. This movement would not, however, feed the pins forward, and another movement has consequently to be introduced.

The lever O—see Fig. 137—bears against a cam on the main shaft and oscillates a horizontal shaft P—see Fig. 136. The peculiar shape of this lever is, by the way, caused by the necessity for it to clear the shoot down which the pins slide. On each end of the shaft P there is an arm that bears against the face of the bar L, which is consequently pushed away from the pins every time the cam moves the lever O forward. The cams are so formed that the bar L moves twice to the right and once to the left in contact with the pins, but on the second stroke to the left the bar is pushed

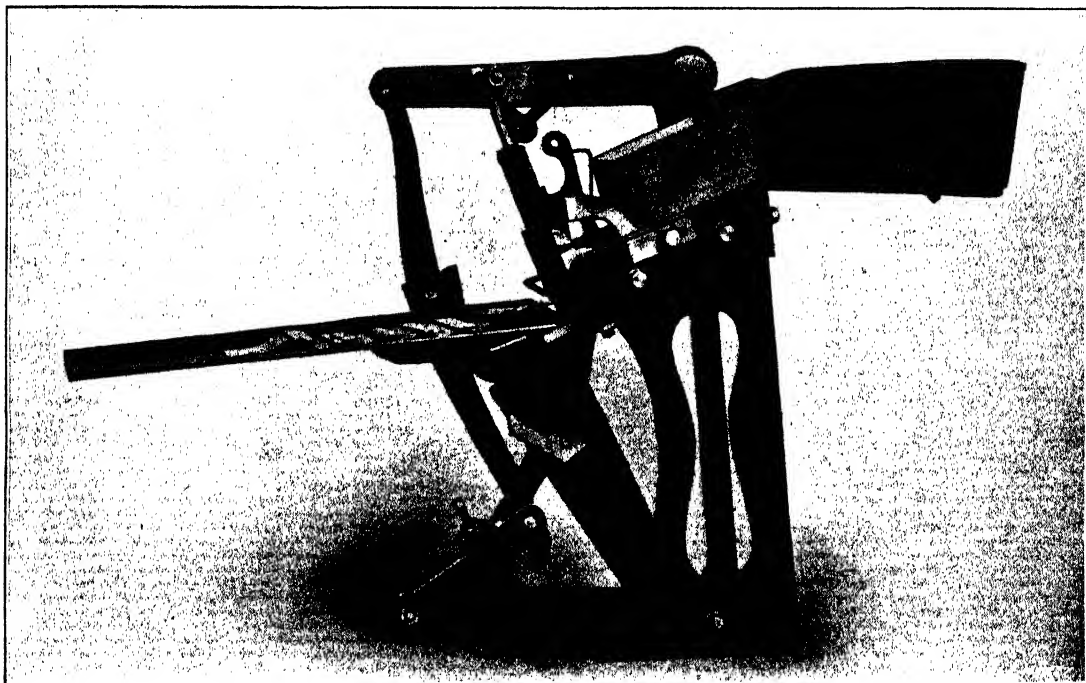

FIG. 138.—PIN-STICKING MACHINE—E. WHITE.

clear of them. As a consequence, the pins progress intermittently to the right, and are finally delivered by a shoot into any convenient receptacle.

The range of sizes of pins that can be made on one machine is governed by the length, which can vary by $\frac{1}{4}$ in. It is therefore usual to arrange five machines on one bed, so that all the sizes of pins in general use can be made. The diameter of the wire does not affect the machine, but it is essential that the wire should be quite round.

The subsequent operations for finishing the pins, by polishing, tinning and so forth, need not be enlarged upon here; but the machine used for sticking them into paper is worthy of a brief description. It is illustrated in Fig. 138.

The pins are thrown into a hopper, the bottom of which slopes down at the front. Down this slope there are cut a number of slots which have rounded edges at the top, and gradually narrow towards the bottom. The pins slide down the little valleys thus formed, until they hang, caught by their heads, at the lower ends of the slots. There are, of course, as many slots as there are to be pins in each row in the paper. In front

BRITISH WIRE-DRAWING AND WIRE-WORKING MACHINERY

of the ends of the slots there is a sliding gate, which can be pulled down by a treadle, and has a thickness equal to the width of the pin heads.

The paper into which the pins are to be stuck is fed upwards from below, between a pair of crimping tools. These tools are arranged just below the points of the pins as they hang in the ends of the slots, and when the moving tool is pushed forward the paper is crimped into a \mathcal{M} shape. The gate is then pulled down by the treadle, and the pins are driven through the apices of the two crimps, passing through serrations in the edges of the tools, which correspond with the spacing of the slots. The crimping tool is then drawn back, the paper pulled forward and the process repeated.

The small machine seen at the end of the bench in Fig. 136 is used for dressing up the pin-making dies. There is a high-speed spindle for grinding out the hollows, while the driving pulley is faced with emery for trimming up the flats.

CHAPTER XVI

NEEDLE MAKING

ALTHOUGH the finished form of the ordinary sewing needle has been fixed for generations past, it is noteworthy that there has been constant progress in the methods used in its manufacture, and new machines which help towards the cheapening of production are still being designed and manufactured. Less than one hundred years ago needles were made entirely by hand, the method being to cut the wire off to the length of the needle, flatten one end with a hammer on an anvil, and indent it on the flat, which was the first process of forming the eye. The wire was then laid on a lead block and the hole punched through it. The head was then filed to shape, and the eye guttered out at the end. The points were produced by grinding or filing. There are instances on record in which orders were being accepted and fulfilled for needles made in this manner at 2s. 6d. per 1,000, finished ready for the market, but the work was naturally tedious and required a high degree of skill and practice. There are, nevertheless, departments in some English needle factories where many of the old-fashioned processes are still employed for making small parcels of special sizes. In a modern needle factory, however, almost all the operations are effected in automatic machines, and those described in this chapter are made by Mr. Edward White, of Redditch, the town in which practically the whole of the needle-making industry of this country is centred. Mr. White, by the way, claims to be the largest maker of this class of machinery in England, and also that his is one of the very few firms in the world able to turn out a complete needle-making plant.

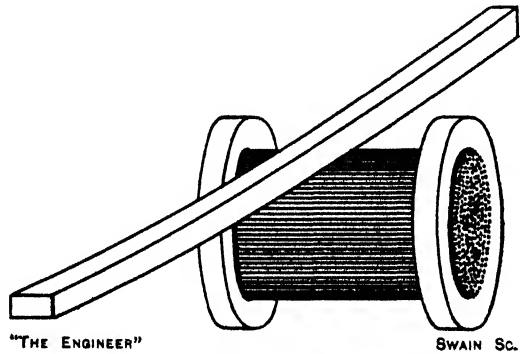

FIG. 139.

The first operation in the manufacture of needles is to cut the wire into lengths, and a very convenient form of machine for this purpose was illustrated and described in Chapter VI. It is, however, the practice of some needle makers to buy the wire ready cut to length. Each length of wire is double the length of the finished product, as needles are made in pairs—head to head.

The wires must next be annealed, and for that purpose they are made up into bundles and slipped into heavy steel rings—a pair of rings for each bundle. The wires are heated to a moderate red heat, taken out of the furnace and placed on a flat iron table, still held by the rings. A man then takes a rubbing file or heavy, slightly curved bar, and pressing on the top of the bundle of wires, as indicated in the sketch, Fig. 139, rubs them backwards and forwards. The result is that the wires revolve on their own axes and by bearing against one another are mutually straightened.

The next operation is to point the wires, which is effected by grinding. At one time the grinding wheels employed were of grit stone, but carborundum wheels are now almost exclusively used, as they not only cut quicker and last longer, but also are much

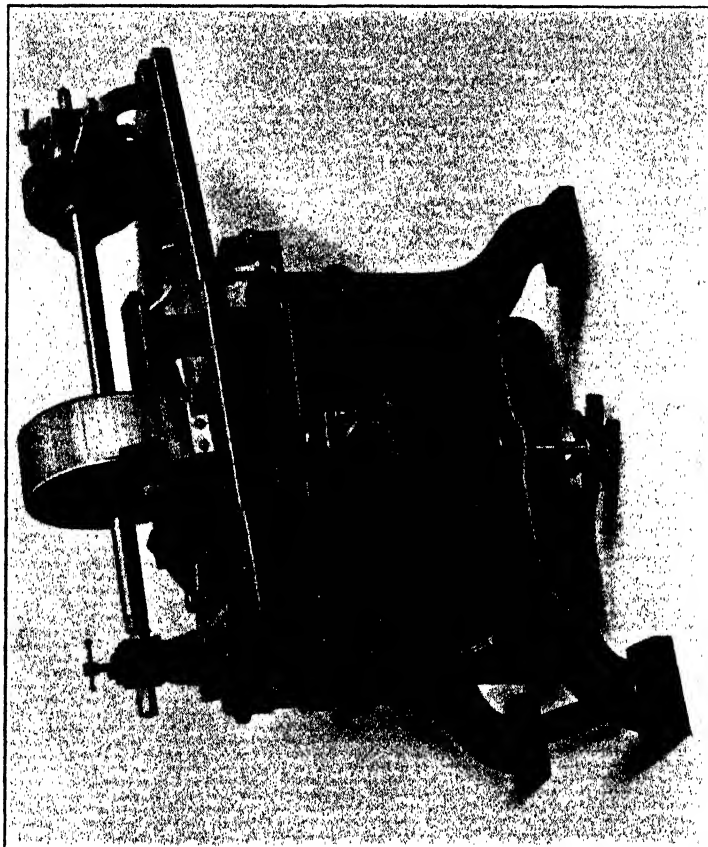

FIG. 141.—POINTING MACHINE FOR LONG NEEDLES—E. WHITE.

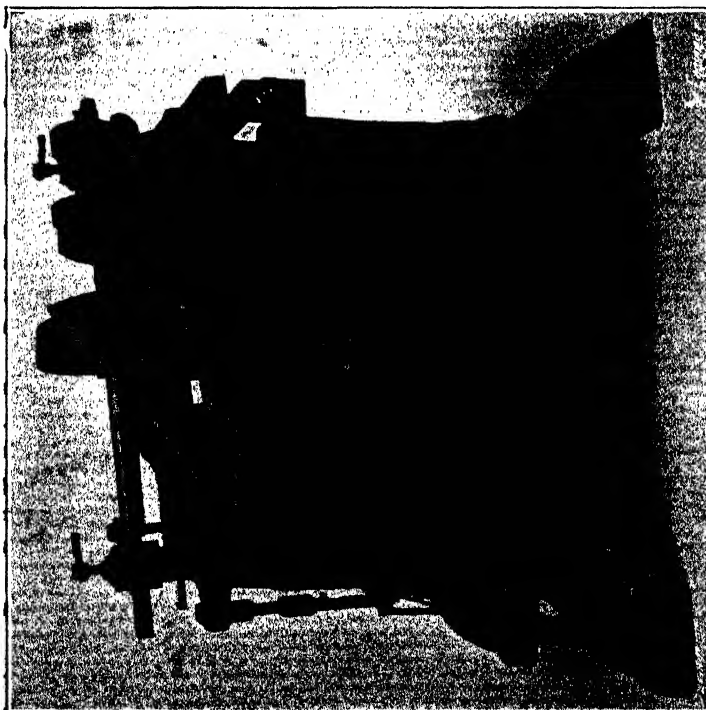

FIG. 140.—NEEDLE-POINTING MACHINE—E. WHITE.

NEEDLE MAKING

less liable to accident through bursting. The general appearance of a needle-pointing machine may be gathered from Fig. 140, while the sketch, Fig. 142, shows the essential working parts and the method of operation. Fig. 141 represents a special machine extended for pointing very long needles.

The point of a needle is not, of course, truly conical, but is rounded, and the gradually increasing taper is produced by the simple expedient of presenting the wire to the grinding wheel at a progressively decreasing angle. That is to say, the extreme point is first produced, and the angle of grinding is gradually reduced until it merges into the parallel part of the needle. This effect is produced by feeding the wires up to the grinding wheel at first at an appreciable angle to its periphery, and so arranging things that by the time they have traversed the width of the wheel the wires are lying tangentially.

On reference to Fig. 142 it will be seen that the wires are fed down a shoot or hopper plate towards the grinding wheel, and are caught between a curved saddle and a rubber-faced feed wheel. In this position they are gripped between the wheel and saddle, with the ends to be pointed projecting beyond the edge of the saddle, and as the feed wheel is rotated the wires roll forward across the grinding wheel. It will be noticed that the feed wheel is set at a considerable angle to the grinding wheel, and that provision is made for adjusting the angle—see Fig. 140—through a considerable range. It is this angle which determines the contour of the point ground on the wire, and it requires considerable skill to set the machine properly, as incorrect setting may result in so much work being put on the grinding wheel at some portion of its width that the wire is overheated and spoiled. When everything is in good running order, the work of grinding is so

evenly distributed across the face of the wheel that the wire is never more than just dull red-hot. After passing right across the grinding wheel, the wires are delivered down a shoot and are returned to the feed side, in the opposite direction, for pointing at the other end.

It should be pointed out that the grinding wheel runs away from the wires, which consequently have to be gripped sufficiently tightly between the feed wheel and the saddle to prevent them being drawn forward by the grinding action. The bearings for the two wheels can be adjusted for accommodating wear, and the feed wheel can be speeded up by gearing when it becomes necessary to true up its rubber face. A fan is provided to carry away the dust produced during grinding. The output of one of these machines is about 40,000 needles per hour.

At this stage the wires still carry a considerable amount of the scale produced when they were annealed, and as the next operation involves the use of some very delicate punches, this scale must first be removed. This work is known in the trade

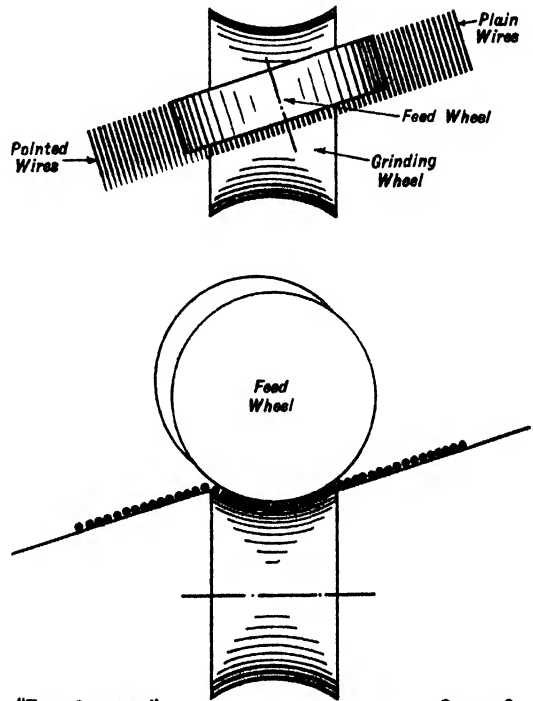

FIG. 142.

BRITISH WIRE-DRAWING AND WIRE-WORKING MACHINERY

as "skimming," and is only carried out at the centre of the wire, where the two needle eyes are to be formed.

The skimming is effected in a machine, of which an illustration is given in Fig. 143, by means of a band faced with emery. The pointed wires are put in a hopper and fall down on to a pair of slowly rotating cast iron discs, between which there is another disc of slightly smaller diameter. This central disc forms a pulley for carrying the emery-faced band, that is driven by the large pulley seen beneath the table of the machine. Outside the cast iron discs there is a saddle between which and the discs the wires are fed. The result is that as the wires are dragged forward by the discs they roll against the saddle and are consequently polished all round by the emery band running below. One of these machines is capable of skimming some 100,000 needles an hour.

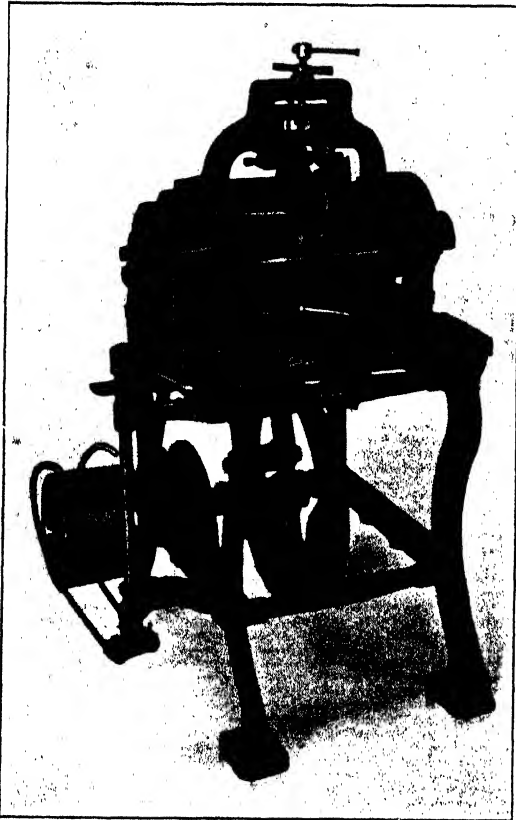

FIG. 143.—SKIMMING MACHINE—E. WHITE.

The next process is to make the eye in the needle, which is performed in two operations, but is often effected in a single machine. There is, however, some divergence of opinion as to the wisdom of carrying out both operations in one machine, and some manufacturers prefer to use two machines, as being less liable to upset the working of the factory in the event of a breakdown. In any case, however, there is little difference in the actual process of making the eyes.

The eye of a needle is punched out, but as a simple punching operation would leave a ragged edge to the hole, the two-fold process just mentioned is adopted. In the first place, the wire is stamped between two dies, which form the two adjacent needle heads, but do not pierce right through the hole. The metal of the wire is squeezed out to form the rounded edges of the eye-hole and spreads out at the sides, as a fin or "flash," while a thin diaphragm is left in the middle of the hole. In the second operation this diaphragm is punched right out, leaving a smooth rounded hole, while the fins are subsequently removed. At one time, and it is not so very long ago, the stamping was done under little drop hammers operated by a foot stirrup, while the piercing was carried out by hand-operated screw presses; but automatic machines are now used for the work almost exclusively.

The simple stamping machine—see Fig. 144—needs little description, as it is similar in general principle to a nail heading machine, except that the wire is presented to the dies sideways instead of end on. The wires are placed in a hopper and are fed forward by a grooved roller, which is geared with the main shaft and consequently feeds a wire in for each stroke of the dies. The wire falls on to a pair of gauges in front of the fixed die and is set in position by a cam and lever bearing against its end.

NEEDLE MAKING

The moving die is pushed back by a cam on the main shaft and when released is driven forward by a spring. After the wire has been stamped it is thrown clear by a pair of cam-actuated forks. The dies are so mounted in the anvil that they can be accurately adjusted in position and are themselves made by stamping with a master die. The die must, naturally, be hardened and tempered after being stamped. These machines are run at such a speed that they will stamp about 10,000 needles an hour.

The eyeing process is carried out in the machine shown in Fig. 145, into which the stamped wires are fed down the inclined table in front. The wires are picked up by a revolving drum and deposited, one at a time, on a pair of horizontal square-threaded

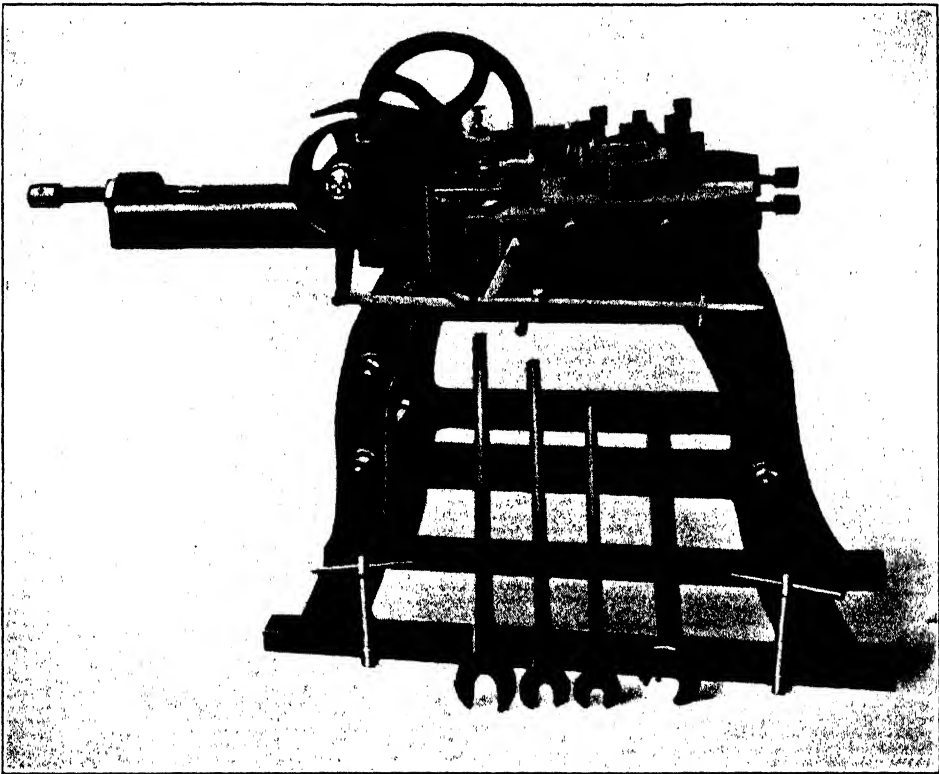

FIG. 144.—STAMPING MACHINE—E. WHITE.

screws. The first few threads of these screws have wide bottoms, so that the wires will readily drop to the bottom, but further on the threads narrow down to confine the wires more precisely. The consequence is that as the screws rotate the wires are carried forward truly normal to the direction of travel. Towards the end of the screws the wires are slid over the top of a knife edge, and as the previous stamping operation has flattened out the centre of the wire this knife edge ensures that the wires will be turned over on the flat in the proper position to be eyed. At the end of the screws the wires are taken by a pair of forks and deposited on the die just before the punch descends and punches out the thin film of metal which has so far blinded the eye. There is a stripper plate to prevent the needles rising again with the punch and a pusher bar to throw the eyed wires on to a tray at the back of the machine. It is noteworthy that the punches are made of the same quality of wire as the needles themselves.

BRITISH WIRE-DRAWING AND WIRE-WORKING MACHINERY

The combined stamping and eyeing machine—see Fig. 146—more closely resembles the eyeing machine just described than the stamping machine shown in Fig. 144, in that both operations are carried out vertically.

The pointed and skimmed wires are fed from a hopper on to the face of a drum furnished with fine longitudinal grooves. The wires are carried round in these grooves, but if a bent wire should appear it will project from the groove and as the drum rotates will catch against a closely fitting fence. This fence is connected with the belt striking gear and the machine will consequently be stopped before any damage is done by the defective wire.

The wires are dropped by the drum on to a pair of feed screws somewhat similar to those of the simple eyeing machine; but as the wires have subsequently to be transferred from the stamping to the eyeing position, the screws are extended beyond the stamping anvil. Opposite the anvil the threads on the screws have one turn cut down much more deeply than the remainder, so that the weight of the wire may be transferred from the screws to the eyeing pad. While the wires are lying on the eyeing pad a pair of gauges descends and the wire is blown against them by a strong blast of air. Provision has also to be made for preventing the screws from continuing to feed the wire forward during the operation of stamping, and that is effected by momentarily moving the whole slide carrying the screws in the opposite direction to the travel of the wire, so that the wire remains stationary. Immediately after the stamping die has done its work, the stop gauges rise and allow the wire to proceed along the feed screws to the eyeing press, which is very similar to that already described.

The bottom die of the stamping bed in these machines is carried in a spherical shaped cup, so that it can be set accurately in position, and there are generally about a dozen impressions, side by side, on each die block, which are used in turn as they wear out. The top die is a little cube of steel with narrow facets along each corner, and these facets are each provided with an impression so that the one die has twelve working faces. The punchings from the eyeing process are drawn away by a fan connected with the underside of the eyeing bed. The output of one of these combined machines is some 25,000 pieces per hour.

The next process is to remove the flash or surplus metal from around the head of the needle. In many places this operation is done by threading the needles on flat pieces of wire and taking them in a pair of wide-nosed pliers or clams and grinding them on an ordinary flat aloxite wheel. In this way the sides of the eyes or "cheeks" are finished, and the wires are then broken through, thus separating them into individual needles for the first time. The grinding is then continued around the head. In more up-to-date works, however, this process is accomplished on an automatic machine, such as that shown in Fig. 147. The needles are broken through immediately after the eyeing process, and are placed in a hopper, which can be seen at the top of the machine. They gravitate down an opening and are caught by a pair of feed wheels below which are grooved round the periphery. In between these grooved wheels there is another roll upon which the needles lie; this roll revolves at a much greater speed than the grooved wheels. As the wheel travels forward, the needles are first gauged or set in position lengthways, and then are carried into a saddle which runs underneath the centre roll. Each needle is thus caused to rotate upon its own axis as it is carried forward. The heads are then brought into contact with two carborundum grinding mills, which are set at the proper angles to shape to the head of the needle. Adjustment is provided by various screws to enable long- and short-eyed work to be dealt with. After passing the mills the needles are stripped from the wheel into a receiving tray on the delivery side of the machine. The output of this machine is about

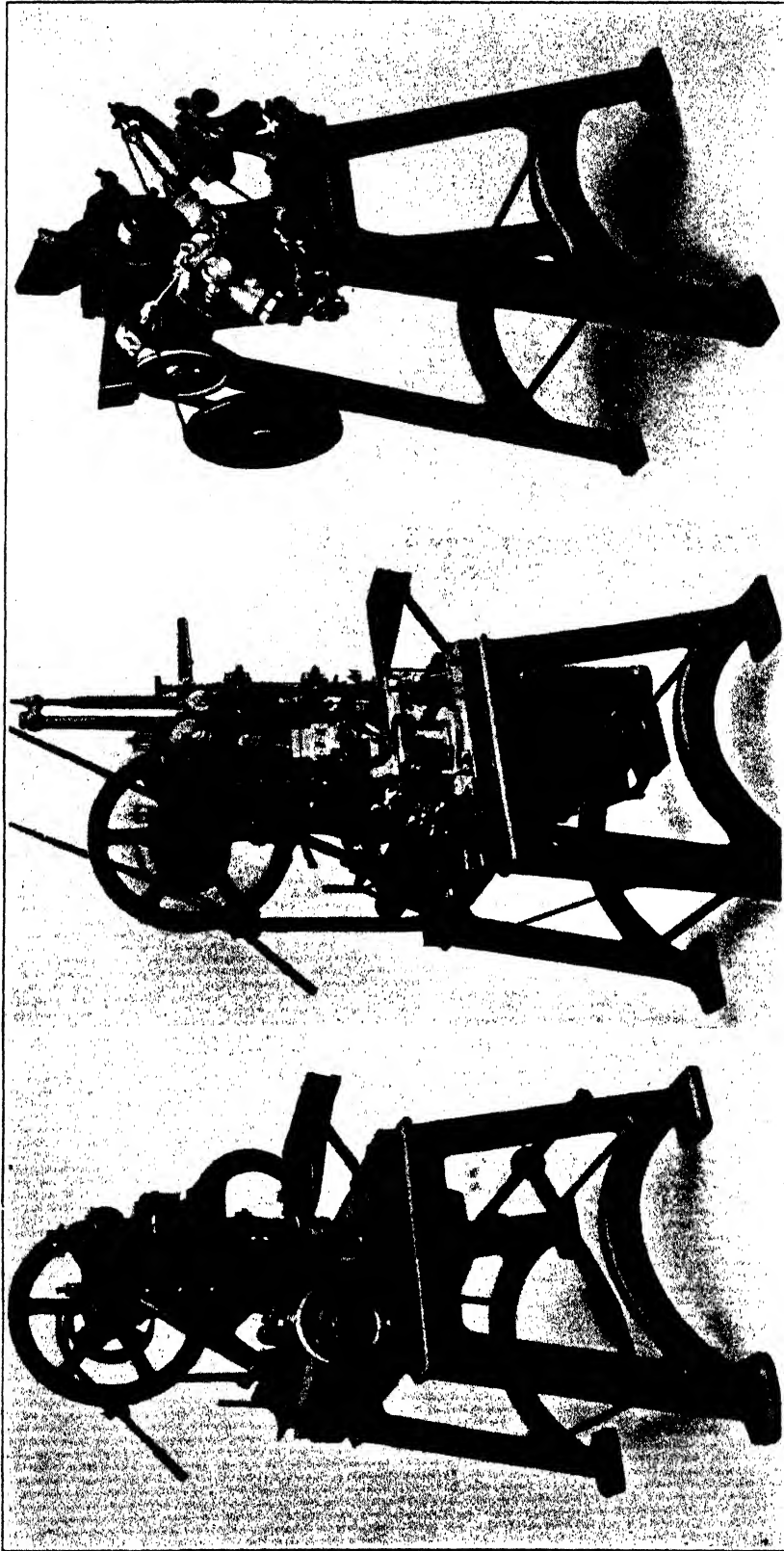

FIG. 145.—AUTOMATIC EYEING MACHINE. FIG. 146.—COMBINED STAMPING AND EYEING MACHINE. FIG. 147.—AUTOMATIC HEAD GRINDING MACHINE.

BRITISH WIRE-DRAWING AND WIRE-WORKING MACHINERY

25,000 needles per hour. The dust from the machine is taken away by a duct connected with an exhaust fan.

The next operation is to harden and temper the needles. This is an operation that requires great care in consequence of the sensitiveness of the material employed and the very small size of the articles. The needles are placed in stacks of about 10,000 on a pan and heated to the required temperature; they are then plunged into cod oil, which hardens them. They are removed from this oil after cooling, and again placed upon pans and put in an oven which is heated to a much lower temperature in order to bring the needles back to a proper temper.

The next process is the polishing of the needles. This is known in the trade as "scouring," and to the uninitiated is a somewhat clumsy process, but it is found to be the cheapest and most effective method of polishing needles and other small articles to a clear surface. The needles are made up into rolls, mixed with emery powder or sand and soft soap, and wrapped round with canvas secured with cord. The rolls range from 28 in. to 30 in. long by about 5 in. in diameter, and may each contain about 40,000 needles. Two of these rolls are placed one under either end of a flat steel plate and on a steel table. The plates are weighted and are reciprocated by gearing as shown in Fig. 148, so that the packets are rolled backwards and forwards. The friction of the needles, among themselves, and with the emery, scours off the scale, and after some twelve hours the packets are opened, the needles thoroughly washed in strong suds, and the rolls made up again with a fresh supply of grit. After several scourings the emery is replaced by putty powder or some such material, in order to give the needles a well-glazed surface.

During the process of scouring the fine points of the needles are naturally dulled somewhat, and the better classes of needles are consequently given a final pass through a machine very like the original pointing machine, in order to give them a keen point. Another refinement is the polishing of the insides of the eyes, which is effected by threading the needles on to emery-covered threads and drawing them backwards and forwards by hand.

The final operation on the needles before they go to the packing department is to assort them according to length, as it is not possible to ensure that they will all be exactly to standard length. The variations between the longest and shortest of any nominal size is only about $\frac{1}{16}$ in., but it is not considered desirable to pack together needles of such divergent lengths. They are consequently passed through the assorting machine shown in Fig. 149.

This machine comprises a slowly rotating wheel with fine grooves in its periphery. The needles are fed into these grooves from a hopper and are all brought level at one end by bearing against a gauge plate. Then, as the needles are carried on by the wheel, the opposite ends are caught by consecutive stripper plates, according to their length, and deflected down shoots into separate pockets. There are generally seven shoots, and the machine will handle about 100,000 needles an hour.

NEEDLE MAKING

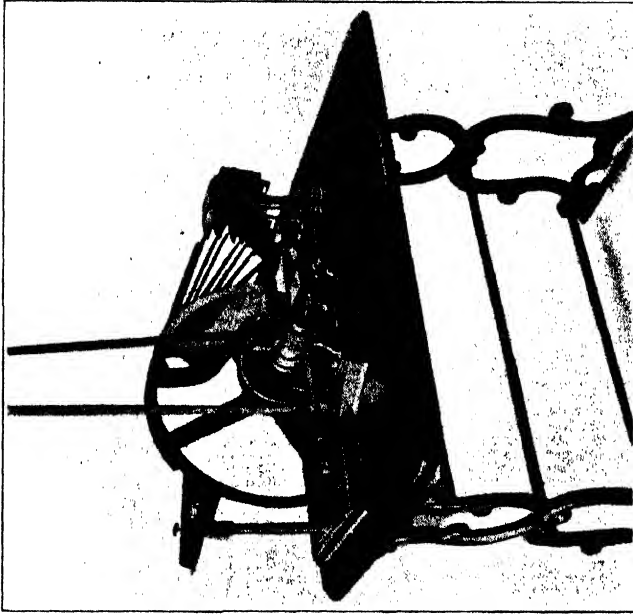

FIG. 149.—ASSORTING MACHINE—E. WHITE.

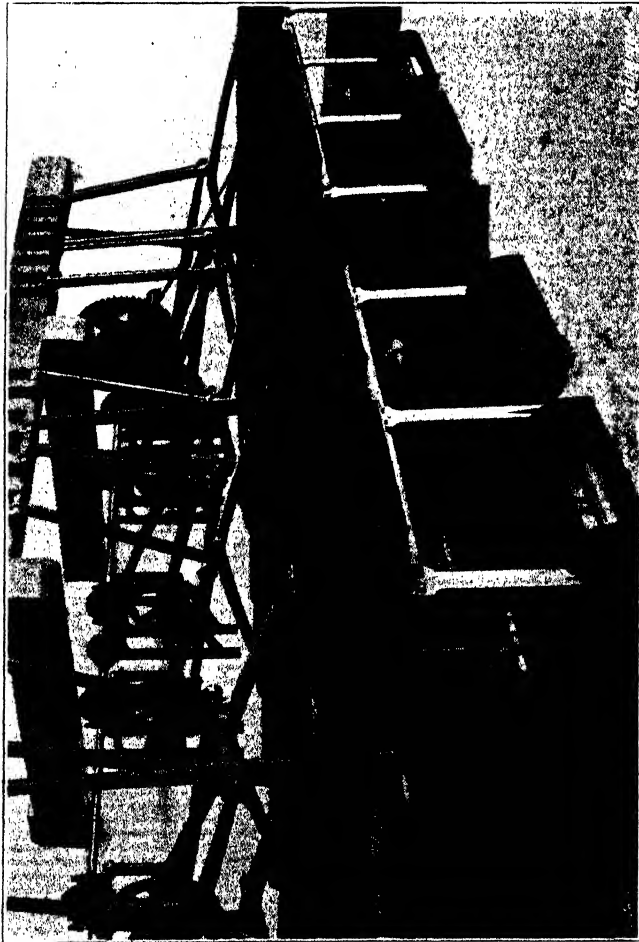

FIG. 148.—SCOURING MILL—E. WHITE.

CHAPTER XVII

SAFETY-PIN MAKING

COMPETITION in the manufacture of the ordinary domestic safety pin has resulted in the evolution of several most ingenious machines, devised with the object of eliminating, as far as possible, the employment of manual labour, and so successful have the inventors of these machines been, that the price at which safety pins can be sold is only very slightly in excess of the cost of the materials they represent. The manufacturing costs have, in fact, been reduced to such an extent by the use of automatic machinery, that the total wages cost, including all processes from the raw material to the finished article, ready for sale, amounts to less than 1d. per gross of pins. This fact is all the more remarkable when it is borne in mind that a very high degree of accuracy has to be maintained or the various processes will be put out of gear, and the pin will not act properly, while the demands of retailers are very exacting as to the finish and style in which the pins are offered.

Through the courtesy of Messrs. George Goodman, of Birmingham, the author had an opportunity of following the whole process of making safety pins, from the reception of the raw materials to the dispatch of the packages, and the following notes, which are based on that exploration, aim at giving a rough outline of the machines and operations adopted, although it is impossible, in the space available, to describe them in detail.

It is noteworthy, in connection with this factory, that the owners claim to have succeeded in meeting German competition, notwithstanding the depreciated currency in that country and the high cost of raw materials in this.

There are, of course, several different types of safety pins, and the one dealt with first is that in which a separate sheet metal cap is used to protect the point. The pins are made by one or the other of two processes, one of which requires two machines only, while in the other the two operations performed by the second machine are separated and three machines are thus required. Small quantities of special pins are made largely by hand, but the appliances then used are comparatively simple, and not nearly so interesting as the automatic machines described below.

The first operation is to straighten, cut off and point the wires, and here a distinctly different process is adopted from that used by needle makers. It is essential that the wires should all be exact to length, as otherwise the subsequent operations would be put out of gear, and it has been found that the necessary exactitude cannot be attained if the pins are pointed with the grinding wheel running away from the point. The grinding has to be done towards the point, and the arrangement of the machine used for the purpose is shown very roughly in the sketch, Fig. 150.

The wire is supplied in the form of ordinary coils, and is placed on a swift at the back of the machine. It is drawn forward through a rotary bord, or straightener, comprising a series of pegs in a rotating frame, through which the wire is pulled by a pair of feed rolls operated by a double-crank feed mechanism. Each stroke of either crank brings forward enough wire to make one pin, which is then cut off.

As the wire is fed forward, it protrudes over a drum turning on a horizontal axis in the front of the machine. This drum is built up of three separate sections or discs.

SAFETY-PIN MAKING

The two outer discs are toothed round their edges—inserted teeth are used so that breakages may be more readily repaired—while the central disc is shod with rubber. The rubber drum is driven by internal gears at double the speed of the toothed discs, and in the same direction.

At the moment that the length of wire is cut off from the stock, a finger comes down from above and pushes the wire squarely into the notches between the teeth of the drum below. Then, as the wire is moved forward by the teeth, it is dragged under a saddle curved to the same shape as the periphery of the drum. The teeth hold the wire square, and at the same time the rubber drum rolls it over against the saddle. At the back of the drum there is a plate against which the wires butt, so that their protrusion in the front is determined exactly.

In front of, and alongside, the drum on the right, there is a fast-running steel mill with file-cut teeth. This mill is hollow-shaped, as indicated in the sketch, and is so

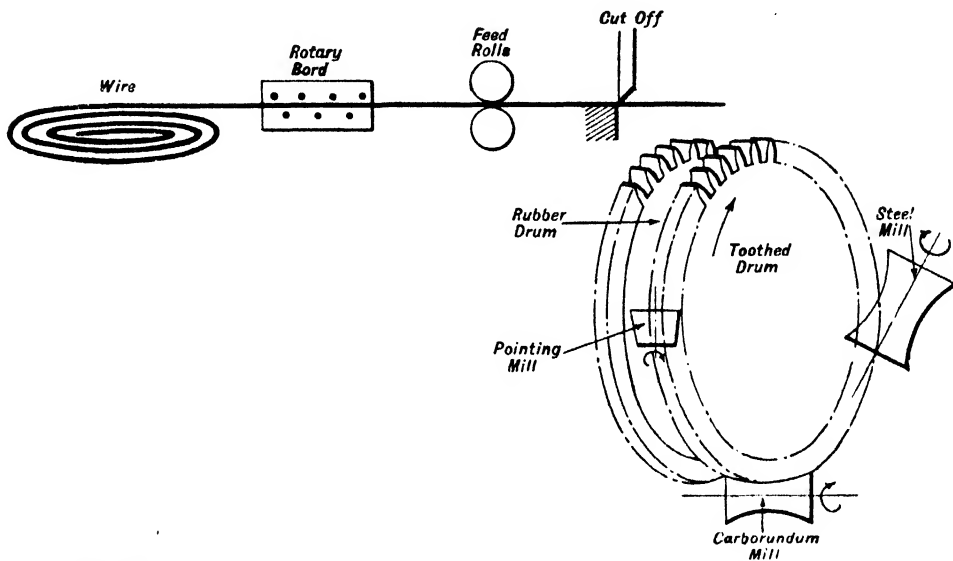

"THE ENGINEER"

SWAIN SC.

FIG. 150.—DIAGRAM OF SAFETY-PIN POINTING MACHINE.

positioned, with regard to the drum, that the desired curved taper is given to the point of the pin. The mill, as already mentioned, rotates towards the point, and an exhauster is used to carry away the swarf behind. The mill is only about 2 in. to 2½ in. in diameter, but runs at 5,000 revolutions per minute, and removes the material more by a rubbing action than by cutting. Although, as already mentioned, it has file-cut teeth, these teeth are very quickly worn down, and the mill then acts like the disc saws used in steel works. There does come a time, however, when the mill becomes too highly polished, and has to be re-cut. The action of the fast-running mill naturally heats up the wire considerably, so much so, in fact, that it is raised to a red heat, but it has no detrimental effect on the metal for such services as those to which safety pins are put.

After the wire has passed the steel mill, it goes on to a corresponding carborundum wheel below, which puts a better finish on the surface. In the sketch, the carborundum mill is shown set at an angle to the drum, like the steel mill; but in some of the machines it is mounted in a frame parallel with the face of the drum, and is given a reciprocating motion, so guided as to follow the contour of the point.

BRITISH WIRE-DRAWING AND WIRE-WORKING MACHINERY

Finally, the wire passes a third mill, which just touches the point at a fairly obtuse angle, and sets it in the same way as an edge tooth is set.

The reason for using a steel mill and then one of carborundum for pointing the pins, instead of attempting to take off all the material with a carborundum wheel, is that the action of working on the square point of the wire would quickly tear the stone to pieces. The steel mill will, however, stand the punishment, and the carborundum has only to put on the finishing touches, so that it lasts for months.

The bearings of these mills have naturally to work in adverse, gritty conditions, but they last without appreciable wear for years. The spindles are made of a special steel, case-hardened and ground, while the bearings are plain cast-iron bushes. A peculiarity of the bearings is that their outside ends are capped. Grease is forced in at this end and gradually extrudes at the other, so that there is no chance of access for grit. The same effect could not be secured if both ends of the bearing were open and the grease supplied at the centre, as one side would be sure to be robbed of grease by the other, and the grit would get in on the dry side.

Although it does not appear at first sight that the amount of work necessary to

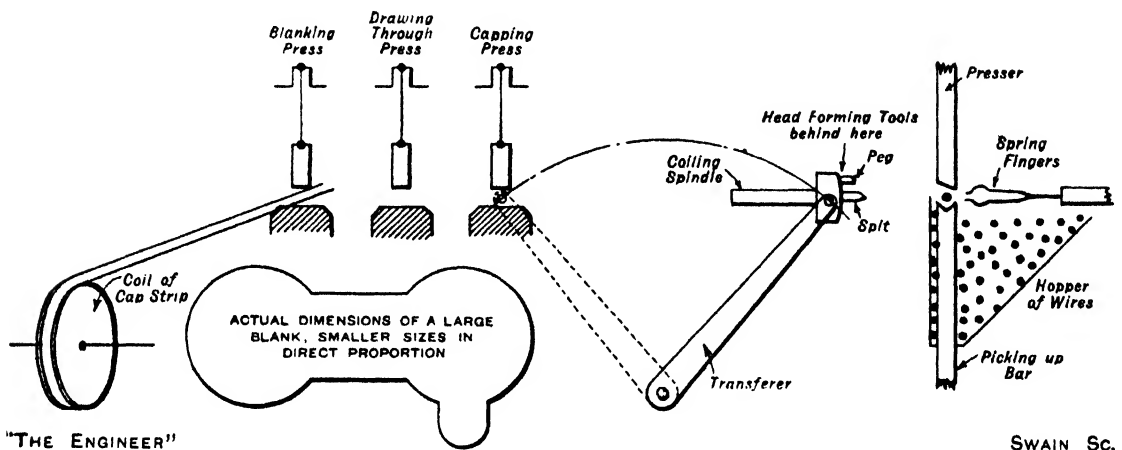

FIG. 151.—DIAGRAM OF GOODMAN'S SAFETY-PIN FORMING MACHINE.

point the pins would be very great, these machines take some 3 horse-power each, which is to be accounted for by the number of high-speed parts—the rotary board, the three mills and the exhauster.

After the wires have passed the three mills they are wiped off the drum into a hopper, from which they are collected at intervals and taken away for the subsequent operations.

In one of the two main processes, as already indicated, the pin is completely formed in a single machine, the invention of Mr. B. L. Goodman, which is almost human-like in its operation, and in which the most complicated movements are timed to act in proper sequence. The machine is fed with the ready-pointed wires and with a coiled strip of metal for making the caps. It turns out complete safety pins.

The sketch—Fig. 151—has been prepared with the object of helping to explain the movements, although it does not pretend to show the form of the various essential parts or their exact relation to one another, while many pieces have had to be omitted altogether in order to reveal the more important ones.

Three distinct functions are performed by the machine. One is the making of the cap, another the formation of the wire stem, and finally the assemblage of the two.

Taking the cap first, the strip is fed by a pair of rolls across a drum, which coats

SAFETY-PIN MAKING

the lower side of the metal with a film of oil, and then between a pair of press tools. These tools cut out a blank more or less of figure-of-eight form—as shown in the sketch. A transfer device then carries the blank to the drawing-through press, where a blunt-ended punch forces the blank through a hole in the bed of the press and completely forms the cap in one operation. Below the bed are two fingers, waiting to receive the cap. They are rocked forward immediately it is received, and push it out through a slot in the bolster. Another transfer device is then brought into action to carry the cap along and place it in the capping press, with its open end to the front, ready to receive the formed wire.

The drawing-through operation is the most troublesome of all the processes, owing to the liability of the tools to scratch the metal. In the case of steel caps, the scratches sometimes appear almost immediately after fitting new tools, in which case the machine must be stopped and the tools polished again. The tools are made of crucible steel, and are left dead hard, automatic lubrication being employed.

The cause of the scratches is not primarily due to the wear of the dies, and it would appear that in cutting the blank, although the tools are kept as nearly perfect as possible, there is a very slight burr or roughness on the top edge of the blank. In the process of drawing the pressure is very great, and minute particles of metal get detached, probably from this burr or edge, and by some means or other become attached to the sides of the die.

This metal forms a slight pimple, which in the early stages can only be seen by a strong magnifying glass. The pimple, however, once formed, cuts into each succeeding cap as it passes, causing the scratches, and rapidly increases in size. The peculiarity of these pimples is that they become as hard as glass, and can only be removed by rubbing down by hand with ragstone.

The pointed wires are supplied from a hopper on the right of the machine and are picked out, one at a time, by a rising bar. The top edge of this narrow bar is cut with a fine V groove, and every time it makes an up-stroke it picks up a wire. It is remarkable that the bar never fails to produce a wire, although no great harm would be done if it did fail. The wire is held in the V groove by a light presser above, until a pair of spring fingers, moving in a horizontal direction, come forward and grasp it.

These fingers carry the wire or stem over to the head-forming tools, shown in the sketch, Fig. 152, which is an end view of part of Fig. 151, looked at from the right. The blunt end of the stem is gripped between the head-forming punch and its bed, while the middle of the wire rests on a fixed spit protruding from the end of a coiling spindle. The spindle is also provided with an eccentrically placed peg, which bears against the other side of the wire and winds it round the spit as the spindle rotates. In the sketch the spindle has made about a third of a revolution since the wire was inserted. The spindle is then rotated one and a half times to form the spring loop and, at the same time the head-finishing tool comes into operation and completes the formation of the J-shaped end that is destined to be fixed in the cap.

The wire stem is now complete, ready for assembly with its cap, to which it is carried by a transferring device. In order to release the wire from the previous opera-

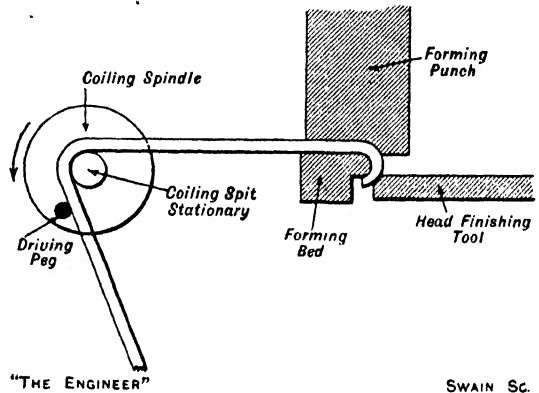

FIG. 152.—HEAD-FORMING TOOLS.

tion, the coiling spindle reverses for a quarter of a revolution, and thus frees the central spit from the grip of the wire. The spit is then withdrawn axially and the coiling spindle recedes to allow the fingers of the transfer device to grip the pin. As soon as the fingers have got hold the head-forming tools release the other end of the wire.

The transferer is carried by an arm that oscillates on a horizontal shaft and also moves in the direction of that axis. It is provided with two spring-controlled fingers which grip the two legs of the bent wire stem and hold them in the normal position of a closed complete pin. To take its hold the transferer moves backward from the front of the machine towards the wire stem, and as soon as the peg of the coiling spindle has been retracted it comes forward again, bringing the pin with it. The arm is then rotated through an angle of about 90 degrees, which brings it opposite the capping tools, as shown by the dotted lines in the sketch. Here the arm moves backward again and inserts the J-shaped end of the wire into the back of the cap in the press, while the point also is entered in its place. At the last part of this stroke the spring fingers are released, a tool comes down in the press and nips the cap tightly on to the J-shaped part of the wire. The completed pin is ejected and the process repeated.

The speed at which these machines work produces from sixty to seventy-five pins per minute, and is practically only limited by the rate at which the drawing process works. To watch them in operation is most fascinating, as there seems to be no hurry about the work, neither is there any appreciable noise, just a gentle clicking. In fact, the pins dropping into the tray below make almost as much noise as the machine itself. Another remarkable fact is that the whole of the mechanism is contained within a framing about the size of an ordinary card table.

The completed pins are collected from the machines periodically and taken to another department, where they are scoured, cleaned, plated, and so forth; but as these processes are common to many trades they need not be enlarged upon here.

The machine described above can be used to produce safety pins of any suitable metal, but, generally speaking, it is used for making the cheaper qualities. For the best quality safety pins another method is used, as, in order to get a perfectly finished article, it is necessary to grind the caps before assembling. The group of machines used for this work comprises units for (1) straightening, cutting and pointing; (2) cap cutting and drawing; (3) cap scouring or grinding; (4) automatic coiling and capping (assembling).

The cap-forming machine needs no further description, as it closely follows that already described; but the hopper feed mechanism for the assembling machine is distinctly interesting and ingenious.

It is evident that the caps must be offered up to the machine in the correct position, or it will not be possible for the wire stem to be entered in place, and although there are many different attitudes which the cap might take up, it is so nearly symmetrical in shape that there is no ready means of guiding it into position. Added to this difficulty there is the peculiarity that the caps will not readily flow out of the bottom of a hopper. They must be taken away from the top of the heap.

The hopper is consequently provided with a constantly running chain, which acts like a ladder dredger, while the store of caps is agitated by two rocking arms. The chain is fitted with tongues on the links, which are so shaped that they will only engage with the opening in the side of a cap in such a manner that the cap is carried forward in the desired attitude. Caps which present themselves to the chain in any other position are ignored and left behind. The correctly placed caps are carried up by the chain and delivered to a shoot, down which they slide into the closing press.

It will be readily appreciated that the teeth on the dredger chain may not always

SAFETY-PIN MAKING

pick up a cap, and there is thus a liability for the feed to be intermittent ; but the rest of the machine goes on regularly, which might result in a wire stem being presented to the closing press when there was no cap there and that stem would be wasted.

To overcome this difficulty the shoot already referred to acts as a stock tube, in which a certain number of caps accumulate. The speeds of the dredger chain and the rest of the machine are so adjusted that, taken over a period of, say, a minute, more caps are picked up out of the hopper than are required by the machine. Towards the upper end the bottom of the shoot is formed as a trap-door, and the distance from this door to the bottom of the shoot is such that it will contain enough caps, according to the law of averages, to make up for the worst likely failure of the chain in picking up caps. In order to guard against over-delivery by the chain, which would choke the mechanism, the trap-door is periodically opened automatically. Then any caps in excess of the necessary stock, which may have come over, will be deflected, and will fall into a special hopper, to be returned to the main hopper by hand.

The closing press, wire coiling mechanism and transferer of this machine are similar to those already described and need no further comment.

There are, of course, several other types of safety pins besides that having a sheet metal cap. One familiar form is made entirely of a single piece of wire, with a coiled loop at either end, and is made by a machine employing some of the principles already described.

In this case the pointed wire is taken from the hopper as before, and one end is inserted in a press which has a V notch in the anvil with a corresponding tool above. When the press descends it squeezes out the end of the wire into a more or less spoon shape, the recess of which ultimately acts as a sheath for the sharp end of the pin when in use.

While the wire is held by the press a coiling spindle advances and makes the spring loop as in the other type of pin. The bent wire, of which the two legs are unequal in length to the extent necessary to provide for the second coil, is then transferred to another spindle for making the loop at the sheath end of the pin. This spindle, however, is of a different type, as it has to make the coil without fouling the point of the wire.

The working end of the spindle looks somewhat like a spiral sea shell with the base cut open. Into the recess thus formed the spoon end of the wire is thrust by the transferer and the spindle immediately begins to rotate. This action naturally coils up the end of the wire—to the extent of one and a half turns—but the point is not also caught up in the recess, as, by the time it is drawn in towards the spindle, the sloping face of the spiral is presented to it. Consequently the point merely slides up this slope until the edge of the recess comes round, when it springs down into place in the spoon and the complete pin is ejected.

A large variety of other pins is made in the factory under review, such as the big ones used by the natives in South Africa for fastening their blanket robes and those, more closely resembling brooches, which are fancied by some young men for fixing their neckties, both of which are made by entirely distinct processes ; but sufficient has been said to indicate the nature of the machinery employed.

There is one other most ingenious machine used in this factory, which takes the pins as they come, closed, from the shops and sticks them through cards for retail trade, but as it is still being developed, while patent rights have not yet been secured, it is not proper to describe it here.

CHAPTER XVIII

WIRE CHAIN MAKING

THERE are, of course, several distinct types of chain made from wire, such, for instance, as jack chain, knotted chain, curb, and trace chain. Each type is made by a different process, and these notes, which are firstly concerned with the last two types, are based on an exploration of the works of Chains (Jewellers), Ltd., in Birmingham, under the guidance of Mr. Vincent, the company's engineer. The machine used to form the wire into the chain links is a most ingenious and complicated affair; but before describing its mechanism it will be well to give some attention to the wire from which the chain is made.

Wire chains are made of all sorts of metals, from gold to steel, and while it is not general to solder the joints of steel chains, with the softer metals soldering is necessary to prevent the links opening under tension. It would obviously be a most tedious business to solder each link separately by ordinary means, so the necessary solder is provided in the body of the wire itself in the form of a core.

The billet of metal from which the wire is to be made is drilled throughout its length, and the hole is filled with solder while the billet is at a red heat. The solder used varies with different metals, as it is necessary that there should be no tendency for the two to separate on account of different coefficients of expansion, while the melting point of the solder must naturally be below that of the wire it is to unite. The cross sectional area of the solder is approximately 15 per cent. of that of the billet, and this proportion is retained throughout the subsequent process of rolling and drawing down to wire.

In the making of the wire for rolled gold chain—that is to say, wire which is cased with a thin film of gold—a further preliminary operation is necessary. For this work a solid-drawn gold tube about 3 ft. long by 2 in. in diameter, and having a wall thickness ranging from $\frac{1}{10}$ in. to $\frac{1}{32}$ in., is obtained, and a yellow metal rod is carefully turned to be just an easy fit inside it. The rod is silvered all over, and when it is slipped into the tube and the two heated to a dull red heat the silver “sweats” the gold and the bar together. The rod is provided with a solder core, as already described, and the composite rod is drawn down to wire of almost any degree of fineness.

In this way a wire of reasonable mechanical strength can be made which has all the appearance, externally, of being of gold throughout, but the film of the rare metal is extremely thin, perhaps only 0.0001 in. thick. In the trade the rolled gold is described as being of $\frac{1}{10}$, $\frac{1}{20}$, $\frac{1}{40}$ and $\frac{1}{60}$ quality; that is, if the wire or sheet is of $\frac{1}{10}$ th quality and 0.01 in. diameter, the gold will be 0.001 in. thick; the $\frac{1}{40}$ th would be 0.00025 in. for the same diameter. The length of time it takes to wear this gold away varies, of course, with the thickness of the material. The $\frac{1}{10}$ th quality is about the best, and is warranted by the makers to wear for twenty years.

Reverting now to the actual making of the chain, it will be readily appreciated that the machine which cuts off and bends the wire into links, threading the links together at the same time, must be of a highly complicated form, and it would be impossible within the bounds of a single chapter fully to describe the whole mechanism. It is hoped, however, that the following explanation may give some idea of the process,

WIRE CHAIN MAKING

and it must be left to the imagination of the reader to fill in the gaps, such as the driving connections between the working tools and the main shafting. It is sufficient for the present purpose to say that all the movements are effected by cams, keyed on to a single shaft and connected with the tools by levers, sometimes assisted by secondary cams or slides where it is necessary to change the plane of movement.

As will be seen from Fig. 153, a chain-making machine is quite a small affair, although it has so many moving parts. The example illustrated is one made by Chains (Jewellers), Ltd., and is capable of turning out about 100 yards per day of eight

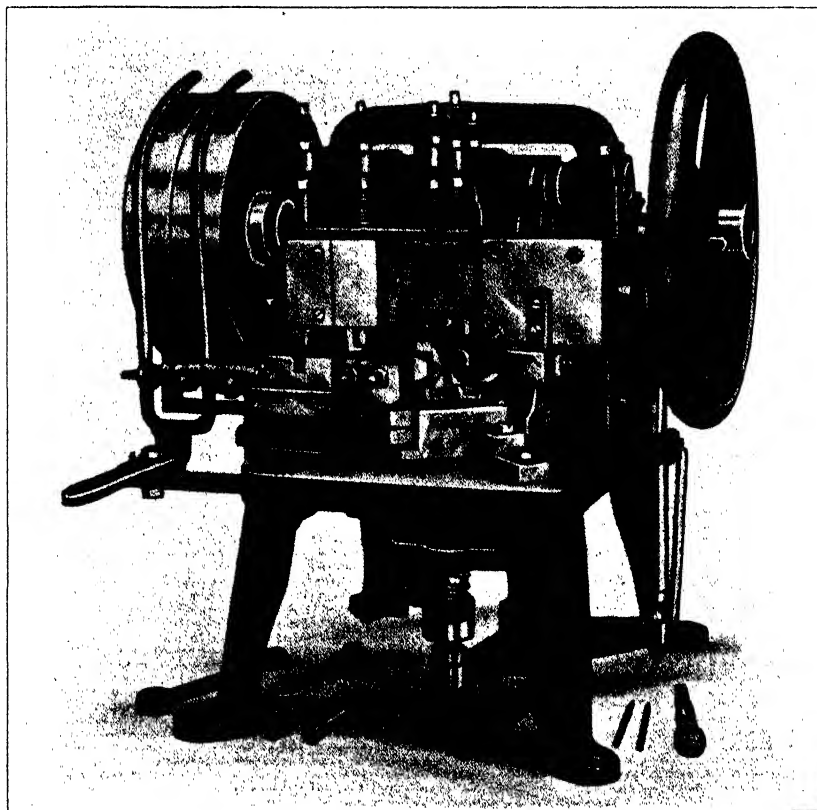

FIG. 153.—TRACE CHAIN MAKING MACHINE.

hours according to the number of links per inch of chain, as every revolution of the cam shaft completes one link.

In this engraving the main cam shaft can be seen running along the top of the machine. The bobbin of wire is carried by a bracket fixed on the left of the framing, and the made chain hangs below the table.

The operation of the machine can best be followed with the aid of Fig. 155, which is merely a diagram indicating the various essential working parts and does not pretend to be to scale.

The stock of wire is drawn off the bobbin through a simple straightener by a feed slide. This feed is given a stroke equal to the length of wire necessary to make one link by the rocking lever indicated, and during the forward stroke the wire is gripped by the pressure of the cam plunger A. On the return stroke the pressure is released. The feed block, by the way, slides under the end of the plunger A. The wire goes on

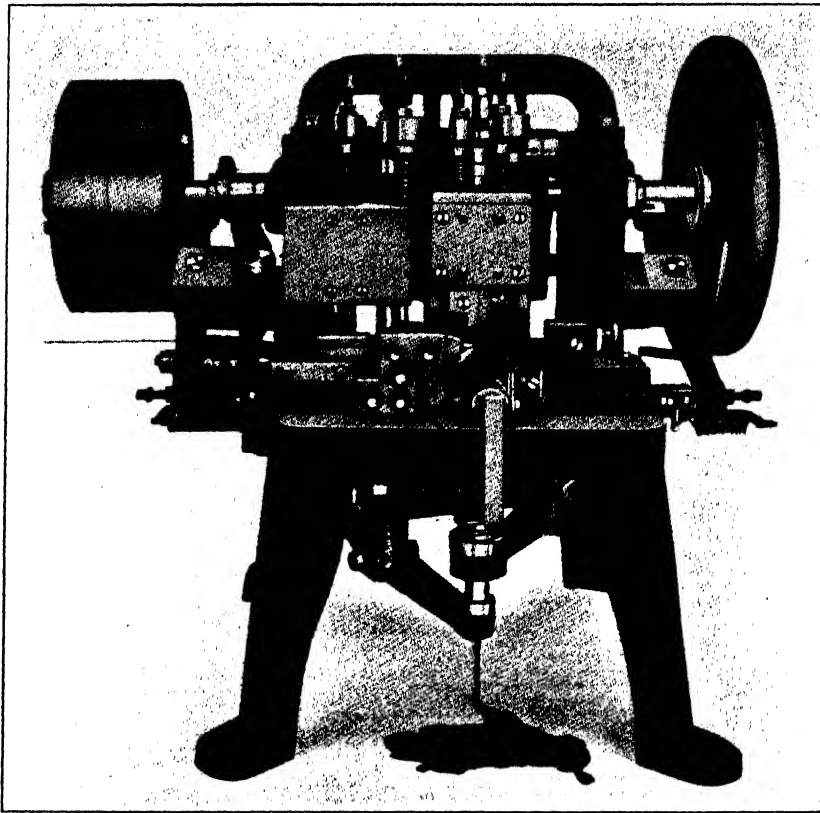
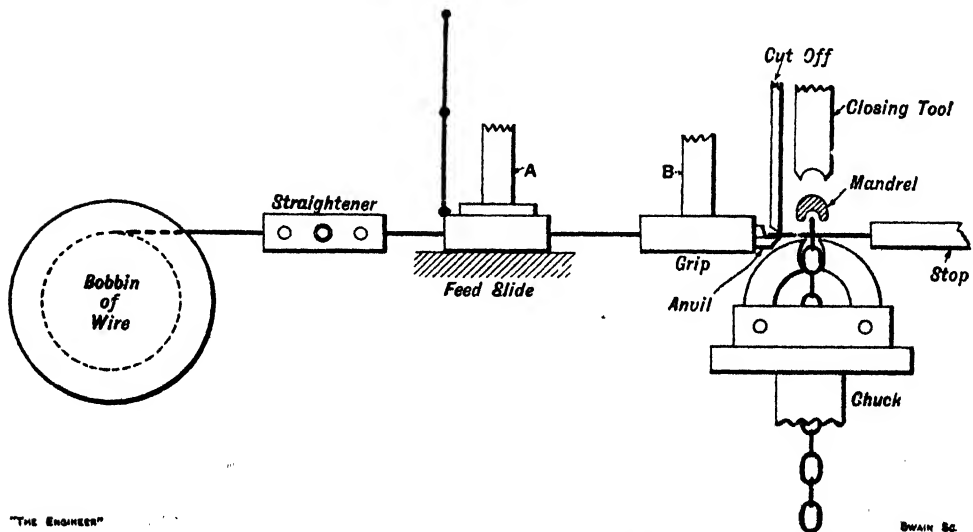

FIG. 154.—CURB CHAIN MACHINE WITH TOP TWISTER.



"THE ENGINEER"

DWAIN & CO.

FIG. 155.—DIAGRAM OF TRACE CHAIN MAKING MACHINE MECHANISM.

to a second grip, on which the plunger B presses during the return stroke of the feed slide. Emerging from the grip, the wire is projected across a gap against a stop and is then cut off by a vertical tool, which just does not touch the anvil below, a very accurate stop being provided to limit its stroke.

WIRE CHAIN MAKING

Now, assuming that chain making has already been started, there will be a link in the gap of the machine, and the new piece of wire will be threaded through this link. Directly below the gap there is what may be described as a two-jaw chuck on a vertical spindle, through which the chain is delivered. When the wire is threaded through the last link the chuck jaws will be open, in the position shown, and the chain is then supported by the bridging wire.

At this moment a horizontal mandrel, the end of which is indicated, comes forward over the wire between the jaws of the chuck, and by moving downward bends the wire into the form of a U. It will be noticed that there is a little groove on the lower side of the mandrel to accommodate the top of the last made link. The jaws of the chuck close on the U just formed and the mandrel retires. A closing tool then descends from above and, by a steady pressure, succeeded by a sharp blow, bends the limbs of the U together to form a closed link. The chuck retains its grip on the chain and makes a quarter revolution, rising slightly at the same time, so as to present the link in the proper position for the next wire to be threaded through. Immediately the chain is supported by the wire again the chuck returns to the position indicated in the sketch and the process is repeated. The mechanism for opening and closing the chuck is indicated in Fig. 156, from which it will be seen that the two jaws are replaceable pieces fixed to rockers pivoted between the cheeks of the body. The shank or spindle of the body is bored and accommodates a hollow rod which spreads out at the top to form a T head. This head bears against two adjusting screws on the rockers, and when the rod is pushed up the jaws are closed on the chain link. The lever for pushing up the rod and the spring for its retraction can be plainly seen in the base of the machine in Fig. 153.

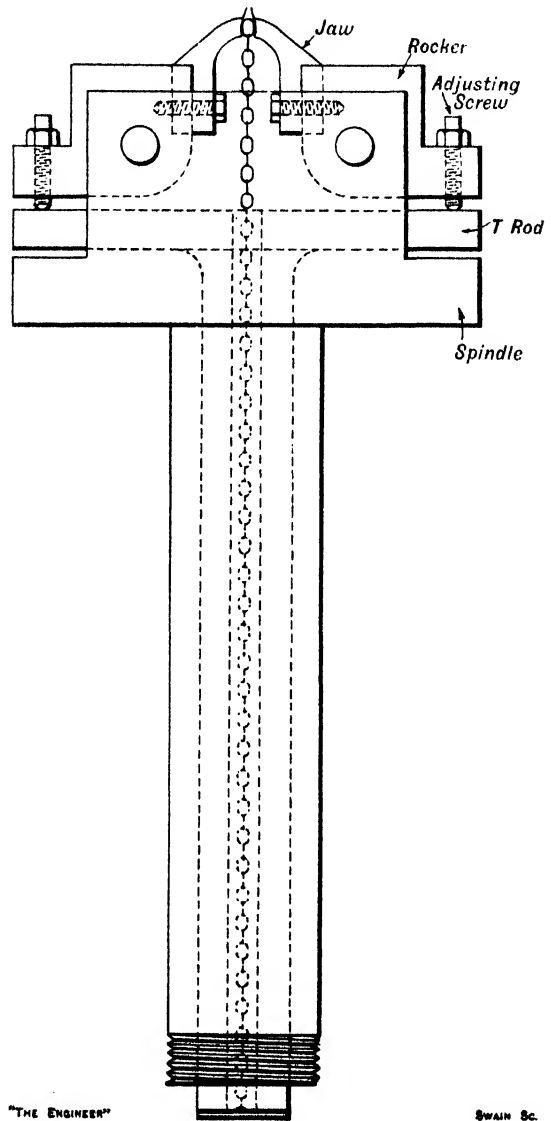

FIG. 156.—CHUCK MECHANISM.

It will be seen that the made chain is continuously rotated by the chuck, and if it were allowed to accumulate on the floor with the twist in it it would become so entangled as to be useless. For this reason a turntable is arranged beneath the machine and is rotated at a quarter of the speed of the cam shaft, so that the turns are taken out of the chain as it is made. This turntable is not shown in Fig. 153, but it is a simple affair, arranged beneath the bench that carries the machine and is driven by a gut band from the cam shaft.

BRITISH WIRE-DRAWING AND WIRE-WORKING MACHINERY

So far the making of trace chains only has been described—that is to say, chain with plain oval links—and it is in this way that chain down to as fine as forty links per inch, made of wire 0.007 in. in diameter, is made. The working tools for making this fine chain are obviously very small and delicate, and it is necessary to use a magnifying glass in setting up the machine.

The machine for making curb chain, that with twisted links, is even more complicated: but, before describing it, it may be as well to follow the trace chain through the subsequent operations.

The joints of the links at this stage are merely pressed together and, except with steel wire, the chain has no appreciable strength, so the joints must be soldered. For this purpose the chain is taken to another machine, in which, after passing over a feed drum, it is heated by Bunsen burners to such a temperature that the solder core in the wire is melted. The wire is then allowed to cool down and all the joints, it will be found, are firmly soldered. The remarkable thing is that the whole chain is not soldered up into a solid bar. The secret of success lies, of course, in careful regulation of the heating and cooling and in the accuracy of the joint made by the closing tool. The chain now only requires cleaning and polishing to be ready for the market. Some

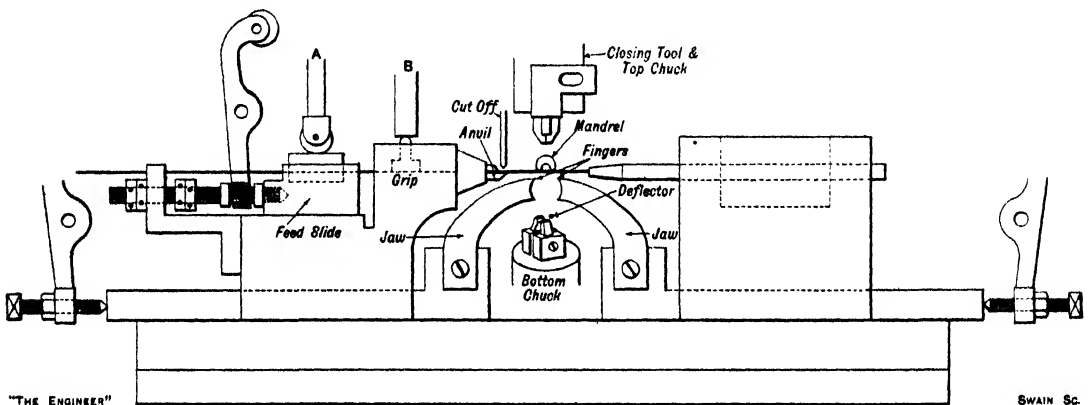

FIG. 157.—CURB CHAIN MAKING MACHINE MECHANISM.

of the fine chain, such as that used by jewellers for guards, is, however, converted to the curb form by the simple expedient of twisting it longitudinally by means of a rotary spindle.

The mechanism of the curb chain machine is the same as that already described, in so far as the straightener and feed gear are concerned, but there are several additional parts at the gap, and they are roughly indicated in Fig. 157. Fig. 154 gives a general view of one of these machines.

The wire grip and cut-off are much the same as those of the trace chain machine, and on the opposite side of the gap there is a stop, but it is provided with a mechanism to withdraw it when it has performed its function. The wire is fed across the gap over the top of two jaws and is cut off as before, while the mandrel then forms a U as for trace chains. Curb chain which is twisted before soldering is generally made of heavier gauge wire than is trace chain, and the closing of the joint is consequently more difficult. For this reason the first operation in forming the oval is for two fingers, indicated in the view, to advance horizontally from the front of the machine on either side of the limbs of the U and to bend the limbs together by approaching one another. The closing tool then comes down from above and completes the joint.

The link in this condition is a plain oval, and it has to be twisted, on itself length-

WIRE CHAIN MAKING

ways, through a quarter turn to make the curb form. This operation is performed by the two chucks or twisters indicated in Fig. 157. The top chuck comes down and grips the top of the link, while the bottom chuck takes hold at the bottom. In order to get the completed chain out of the way of the bottom chuck jaws, so that they may grip the link sideways, a little deflector advances from the front of the machine and pushes the chain aside to expose the bottom of the last made link, which is still held by the main forming jaws.

As soon as the chucks have got hold of the link the forming jaws open, the stop retiring as they swing back to make room for them. The chucks then make a quarter turn, relatively to one another, and the link is finished. In some machines the twist is made by the bottom chuck, and then a receiving turntable is needed for the chain; but in others the top chuck makes the twist, and a turntable then becomes unnecessary,

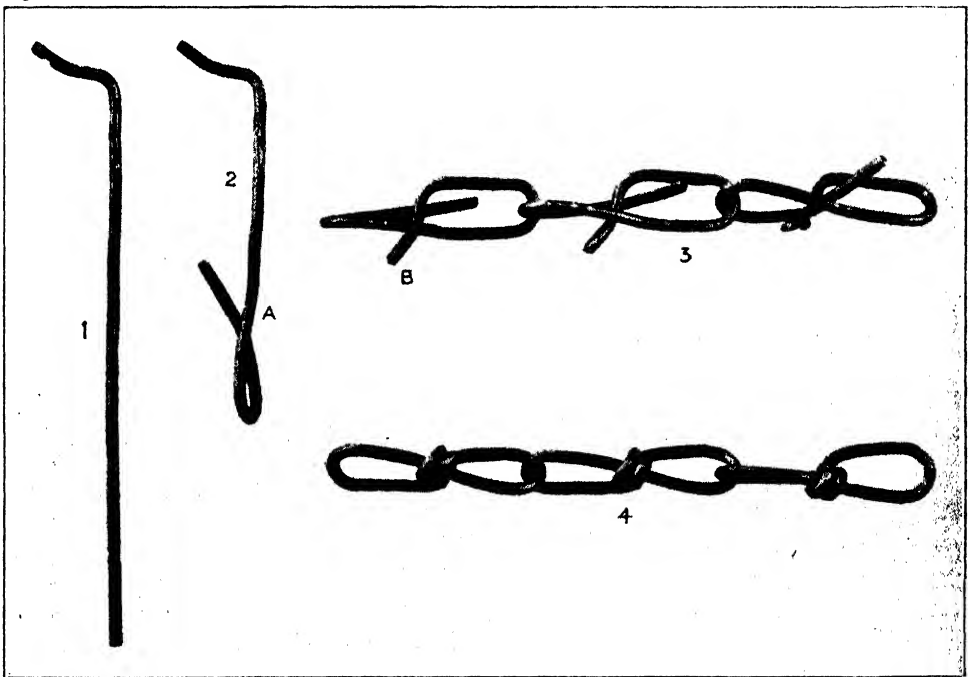

FIG. 158.—FOUR STAGES IN MAKING KNOTTED CHAIN.

as the twisting brings the link into position for receiving the next piece of wire. In either case it is, of course, necessary for the chuck last holding the link to rise slightly at the end of the operation so as to bring the link high enough for the next wire to be threaded through.

The subsequent operations of soldering and so forth are the same as with trace chain, but curb chain is generally passed through a simple swaging machine, after it is soldered, to level out the links.

Of the other two types of chain mentioned at the beginning of this chapter, the manufacture of jack chain involves the employment of comparatively simple machinery; but the machines used for making knotted chain are ingenious in the extreme. Both forms of chain, besides a variety of others, are made by the Aston Chain and Hook Company, Ltd., of Bromford Lane, Erdington, Birmingham, and the following notes are based on the practice at that factory.

BRITISH WIRE-DRAWING AND WIRE-WORKING MACHINERY

Jack chain is, of course, of that form in which each link comprises two circular loops set in planes at right angles to one another, and is used for a variety of purposes where no great tensile strength is required. The strength is, however, materially increased by folding each link back on itself, so that one of the loops is duplicated and "Double Jack" chain is produced. The process of making both varieties is very similar.

The wire is fed into the machine transversely, and is cut off in the usual manner. A vertical peg carried by a horizontal slide then pushes the wire between two dies and forms a U. In the case of double jack chain, both the limbs of the U are of equal length, but for single chain one is shorter than the other. The dies then close together in a horizontal plane and bend the wire round the back of the peg, so that a complete circle is formed with a tang projecting. The tang is either double or single strand, according to the type of chain being made. At this point a horizontal mandrel moves forward over the top of the tang, and takes a stroke downward, which starts to form the second loop of the link. A tool moving forward from the back and another coming down from above complete the folding of the wire round the mandrel, and as soon as the mandrel has been retracted, the wire for the next link is projected through that just completed. It will be appreciated that the shape of the links obviates any trouble through the chain being twisted and kinked in manufacture, as each link is formed in a position appropriate for the reception of the next one in sequence. The result is that the finished chain can be led straight away to a tub or any other handy receptacle.

The machine used for making knotted chain—see Fig. 158—is a far more complicated affair, and although it would require an inordinate amount of space to describe its mechanism in detail, it may be of interest to indicate the general principles of its action. It is noteworthy, incidentally, that while more than one claim has been made for the origination of the design of the knotted chain machine, there are minor variations in almost every factory employing them, and the general practice is for the users to make their own machines.

The chief characteristic of the knotted link chain is, of course, the fact that in one operation, and without any welding or soldering, a chain is produced, which has practically 100 per cent. of the strength of the wire from which it is made. On the other hand, the chain is not very flexible, as the length of the links cannot be reduced to the same limits as with other types of chain. It has, however, a large variety of applications and has the great merit of cheapness.

One of the peculiarities of the machines used to make these chains is that most of the movements are of considerable extent, and consequently they are actuated by cranks, instead of cams as is the case with round link chains. It is not, however, necessary to describe these parts of the machine, but rather to go on directly to explain the operations it performs, with the assistance of the engraving, Fig. 158, and the diagrammatic sketch, Fig. 159.

The wire is taken off a spool at the back of the machine, and is fed forward by a reciprocating slide. In view of the facts that a considerable length of wire has to be supplied for each link—some 5 in. for a link $1\frac{1}{2}$ in. long—and that it must be delivered quickly, in order not to delay the other operations, the feed has a very powerful grip on the wire. This grip is effected somewhat as indicated in Fig. 160. In the feed slide there is pivoted a horizontal lever, beneath the front end of which the wire runs. Under the rear end of this lever there is a wedge. The wedge and the frame carrying the lever are free to slide on one another through a short distance. At the back end of the feed stroke the slide runs under a leaf spring, which checks it, on starting the

WIRE CHAIN MAKING

forward stroke, just sufficiently to make the lever ride up the wedge and grip the wire. The pull of the feed on the wire then tends to accentuate the grip. In order to prevent the wire running back on the return stroke, it is passed through a split die—as indicated in Fig. 160. The inlet side of this die has a rounded corner, while the opposite edge is sharp and square, so that it bites the wire and holds it from being drawn back. On the return stroke, the relative movement of the gripping lever and the wedge releases the wire.

After passing through the die the wire is led through a tapered spout, which is pivoted at the rear end—as shown in Fig. 159. This spout guides the wire in front of the cut-off tool, and swings back with it as it is sheared off. The wire is shot right

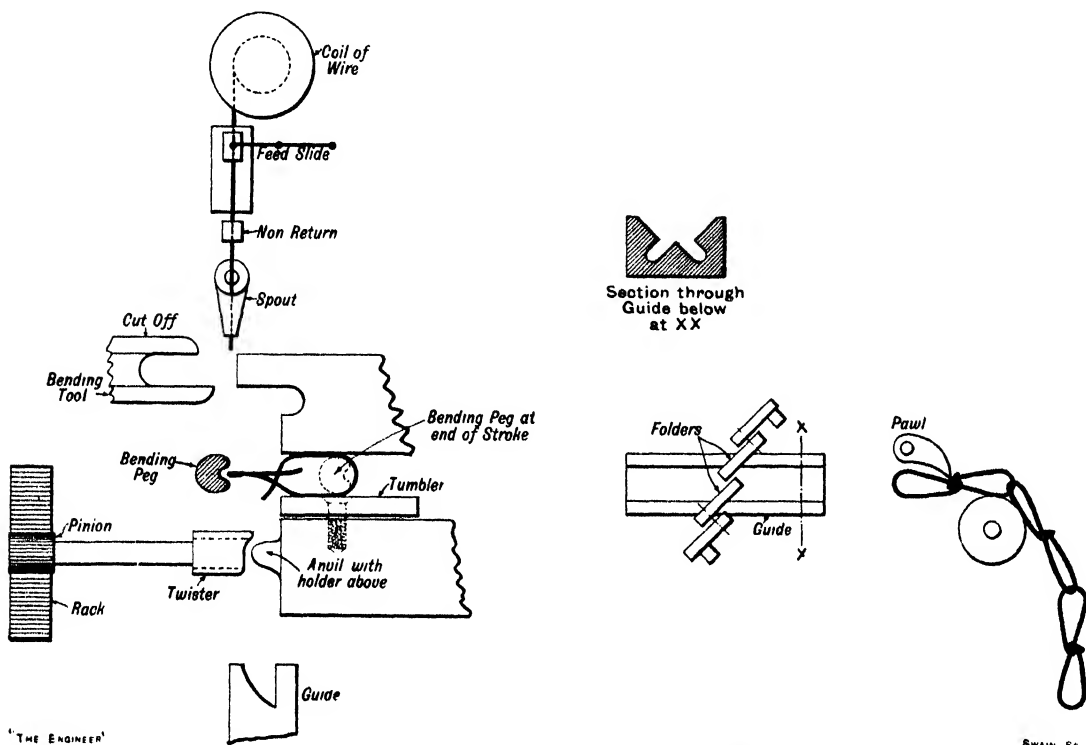

FIG. 159.—DIAGRAM OF KNOTTED CHAIN MACHINE.

across the machine, and is caught at the front in a V-shaped guide, which ensures that it has passed over a little anvil projecting from the frame of the machine.

The cut-off slide now moves forward, bringing with it a bending tool, which forms the wire, against the back of the fixed cutter, into the shape shown at 1 in Fig. 158. As soon as the wire is over the top of the anvil, which is shaped much like the blunt end of an almond, a gripper comes down on the top and holds it tight. (This gripper is not shown in the diagram.) The next operation is the bending of the first loop of the link, and this is effected by a hollow twister, driven by a rack and pinion—as indicated in Fig. 159. The end of the twister has a projecting beak, which catches the wire and twists it downwards round the anvil—as shown at 2 in Fig. 158. At the same time, another slight projection produces the faint kink in the shank of the wire seen at A.

The main slide now moves to the right and forces the bending peg—see Fig. 159—against the straight part of the wire, where it bridges the gap between the fixed tool

BRITISH WIRE-DRAWING AND WIRE-WORKING MACHINERY

and the tumbler. The wire is thus doubled up and takes the form shown at 3 in Fig. 158, with the two ends overlapping one another. The tumbler must now be dropped, so that the projecting end B of the new link may be cleared as the chain moves on to the right. This action is effected by a slope on the main slide riding under the tumbler, which is pivoted to the frame. In machines working on large wire this tumbler needs careful attention, as it has to take the heavy end pressure produced in bending the wire, but must at the same time be free to swing on its pivot.

The links are drawn forward, as they are made, by a pawl on the extreme right

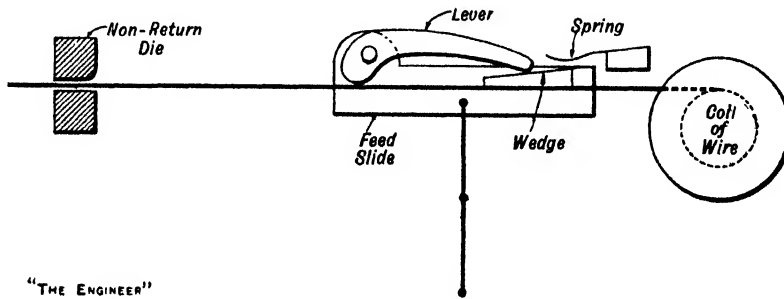
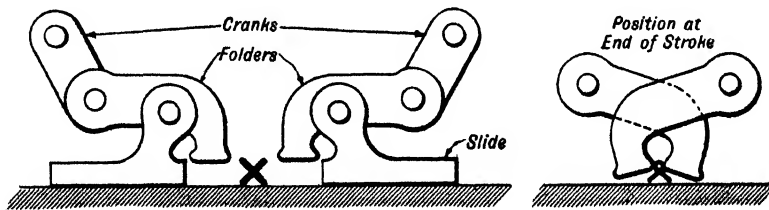

FIG. 160.—FEED GEAR.

of the machine—see Fig. 159—which works with the main slide and keeps the chain in tension. The links then run into a guide which has a section, as shown in detail in Fig. 159, that securely grips the lower limbs of the link. It will be noticed in Fig. 158 that the chain is twisted through an angle of 45 degrees between the bending tools and the guide, so that the links go through the guide with the two projecting ends uppermost. The final operation is the folding over of these two ends to form the knot at the centre of the link—as shown at 4 in Fig. 158.

This operation is effected by two rocking tools that slide in ways set diagonally across the machine, and while it is in progress the link is held by two pressers that



SWAIN SC.

FIG. 161.—FOLDING TOOLS.

push it down firmly into the guide. The action of the folders is indicated in the sketch, Fig. 161, which shows that they are pivoted in sliding blocks and, at their rear ends, are connected with cranks that are given an oscillating motion by powerful toggle levers. The result is that during the first part of the stroke the nose of the folder rises slightly and pushes the end of the wire over the shank. At the end of the stroke the crank is rising and the nose of the tool is consequently depressed, so that the end is folded tight round the shank. Both the ends are, of course, folded simultaneously, and it takes some skill on the part of the toolmaker to arrange the folders so that they will not foul one another in passing. The strength of the chain naturally

WIRE CHAIN MAKING

depends on the security of the knots made by the folders, and it is rather surprising how tightly these folds are made, a fact which can be tested by cutting one of the links at the end, when, in a well-made chain, it will be found that the two parts still hold together quite firmly.

After the folding operation the chain is complete and is collected in any convenient manner, but it is generally treated in a tumbling barrel to remove any roughness which may have been left by the tools, and is sometimes galvanised or lacquered.

At the works of the Aston Company chain of this type is made in a variety of sizes ranging from No. 2 to No. 18 gauge.

CHAPTER XIX

WIRE FLATTENING

FLATTENED wire is used for a great variety of purposes, and ranges from the extremely thin tempered steel used for the reeds of musical instruments, through the comparatively stiff wire for scratch brushes, to heavy "stuff," $\frac{1}{4}$ in. or more in thickness.

It is, of course, quite possible to draw rectangular wire through dies in the same way as the ordinary round wire is drawn. In fact, sections approaching a square in proportions are generally produced in that way, but when the thickness is small in proportion to the width of section the drawing operation is less economical.

Flattened wire may be required to be so thin in proportion to its width as to be more correctly described as strip, and this strip in both steel and non-ferrous metals is usually produced by cold rolling between hardened steel rolls. The class of material, termed strip, includes a very wide range of dimensions, covering as it does any comparatively thin metal which is produced in long continuous lengths, and its width may

be anything from $\frac{1}{4}$ in. or less up to 12 in. or even 18 in. The difference between wire flattening and strip rolling proper lies merely in the form of the metal before the rolling operation. As mentioned above, wire flattening is rolling from the round section, while strip rolling starts with metal which has already been reduced to a rectangular section by hot rolling, casting or drawing.

In the case of steel, cold-rolled steel strip is obtained by rolling hot-rolled strip, the cold rolling process merely reducing the thickness with accuracy to the required gauge. Rolling gives a bright and clean surface, and incidentally

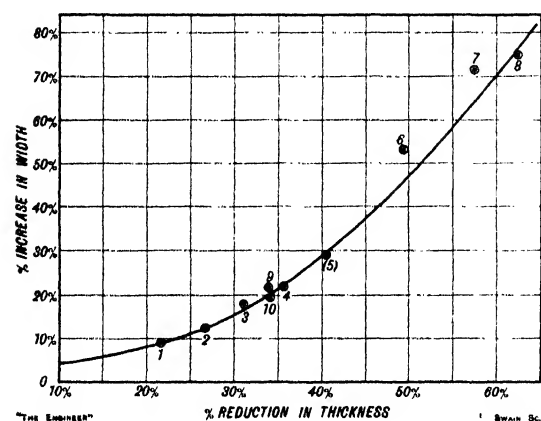

FIG. 162.

hardens and increases the strength of the metal. Copper and brass strip may be cold rolled from cast slabs, and indeed every metal or alloy requires its own special treatment. Subsequently the strip may be slit in multiple circular shearing machines into a number of narrower strips.

Rolling is the most economical method for comparatively wide strips, but for strips less than 1 in. wide the wire flattening operation is preferred, especially where a smooth slightly rounded edge is desired.

Flattened wire is mainly required in steel and copper, but nickel silver and other metals or alloys are also produced in this form in considerable quantities. In all cases the material before rolling is in the form of drawn or rolled circular wire of the correct diameter to give the desired width when flattened to the required thickness. The relation between linear and transverse extension of material produced in rolling is a question which has received considerable study, but so far it has been found impossible

WIRE FLATTENING

to formulate any general rule, since transverse extension or spread depends on many conditions, all of which permit of a wide variation.

The chief factors in the problem are :—(1) The nature of metal rolled. Thus soft metals tend to spread more than hard metals. (2) The dimensions and shape of section rolled ; a section approaching a square or circle before rolling will spread to a greater extent than will a flat rectangular section in which the width is great in proportion to the thickness. (3) The reduction per cent. in thickness taken at one pass. Naturally the greater the reduction in proportion to the thickness the greater the spread. (4) The diameter of the rolls. With the same reduction in thickness the spreading appears to vary with the diameter of the rolls employed. Experiments on this subject carried out by Mr. C. E. Davies, of Messrs. Robertson's, Bedford, have indicated that the larger the roll diameter the greater the spread. See Tests (9) and (10), Table I. (5) Probably a variation in rolling speed has some effect, and even the condition of the roll surfaces has an influence, as highly polished well-lubricated rolls facilitate spreading, this effect being more marked in the case of comparatively wide strip.

In Table I. there are given some figures from wire flattening experiments, which

TABLE I.

Test No.	Diameter before rolling.	Thickness after rolling.	Width after rolling.	Per cent. reduction in thickness.	Per cent. increase in width.	Roll diameter.	Rolling speed, feet per min.
	in.	in.	in.			in.	
(1)	0.5	0.392	0.545	21.5	9.0	10	104
(2)	0.5	0.368	0.559	26.5	11.8	10	104
(3)	0.5	0.344	0.589	31.0	17.8	10	104
(4)	0.5	0.322	0.608	35.5	21.5	10	104
(5)	0.5	0.297	0.643	40.5	28.5	10	104
(6)	0.1875	0.095	0.287	49.5	53.0	10	104
(7)	0.2187	0.094	0.375	57.5	71.5	10	104
(8)	0.252	0.094	0.440	62.5	74.5	10	104
(9)	0.1406	0.093	0.171	33.8	21.5	9	—
(10)	0.1406	0.093	0.167	33.8	18.8	4	—

NOTES.—In all these tests steel wire was rolled. Tests (1) to (5) inclusive were made on ordinary hot rolled mild steel rod, Tests (6) to (10) inclusive being on drawn steel wire (soft, but not annealed).

give an idea of the amount of spread likely to occur with varied conditions, while the results are plotted in the form of a curve in Fig. 162.

Wire flattening requires essentially only a simple form of rolling mill, of which a typical example is illustrated in the line drawing Fig. 163. The machine comprises a pair of narrow-faced rolls, usually of hardened steel, running in bearings fitted in strong cast iron or steel frames. The top roll is adjustable, in order to permit the regulation of the thickness rolled, by means of steel screws and spanners. Spur pinions are keyed to the roll spindles for gearing the two rolls together, and any convenient gear is provided for driving the machine. The rolls themselves must be of a special alloy steel, hardened to the highest possible degree, and finished by grinding. The hardness should be between 90 and 100 degrees by scleroscope, as the rolling of round wire and narrow strip is the most severe test of the quality of a roll, and even with the best possible steel and the greatest degree of hardness the metal will wear grooves in the roll surface.

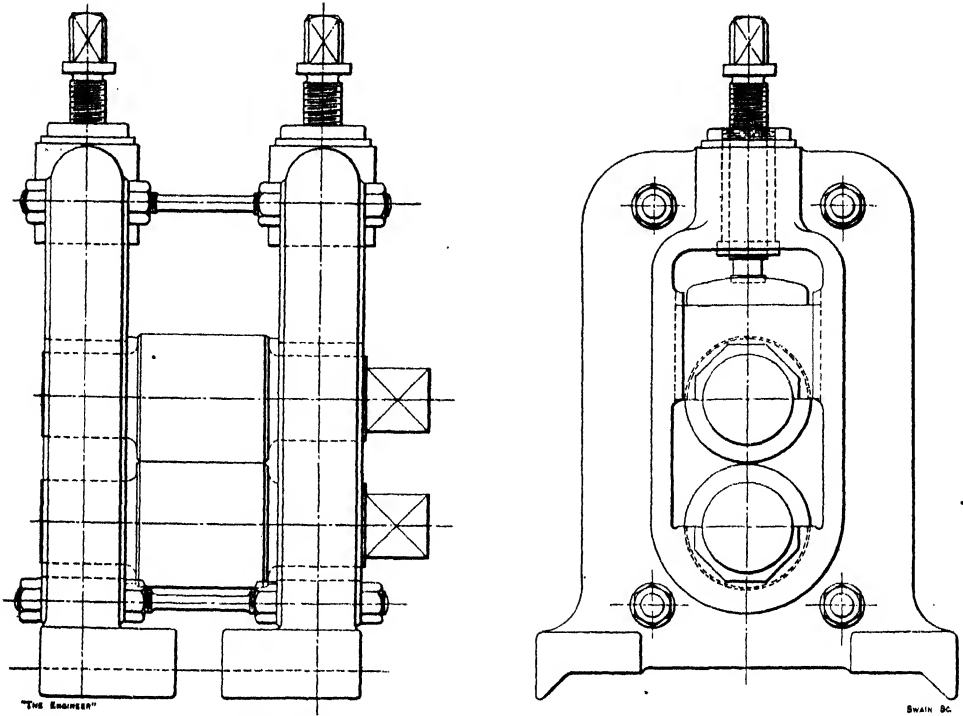

FIG. 163.—GENERAL ARRANGEMENT OF WIRE FLATTENING MILL.

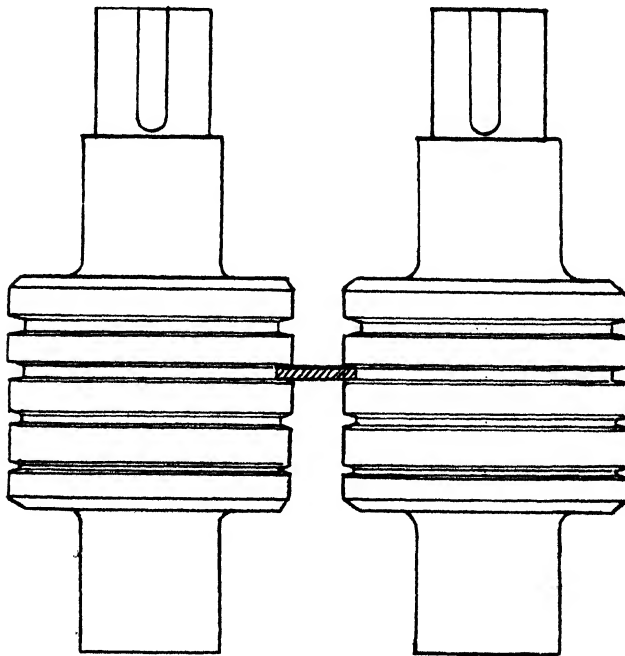

FIG. 164.—EDGING ROLLS.

On this account it is usual to alter periodically the position of rolling across the face of the roll, so as to wear the surface as uniformly as possible, until re-grinding is necessary.

WIRE FLATTENING

Other important items are the roll bearings, and the method of lubrication, owing to the heavy pressures imposed. In the simple form of mill shown in Fig. 163 the roll necks are supported in plain open bearings with grease lubrication, and in order to

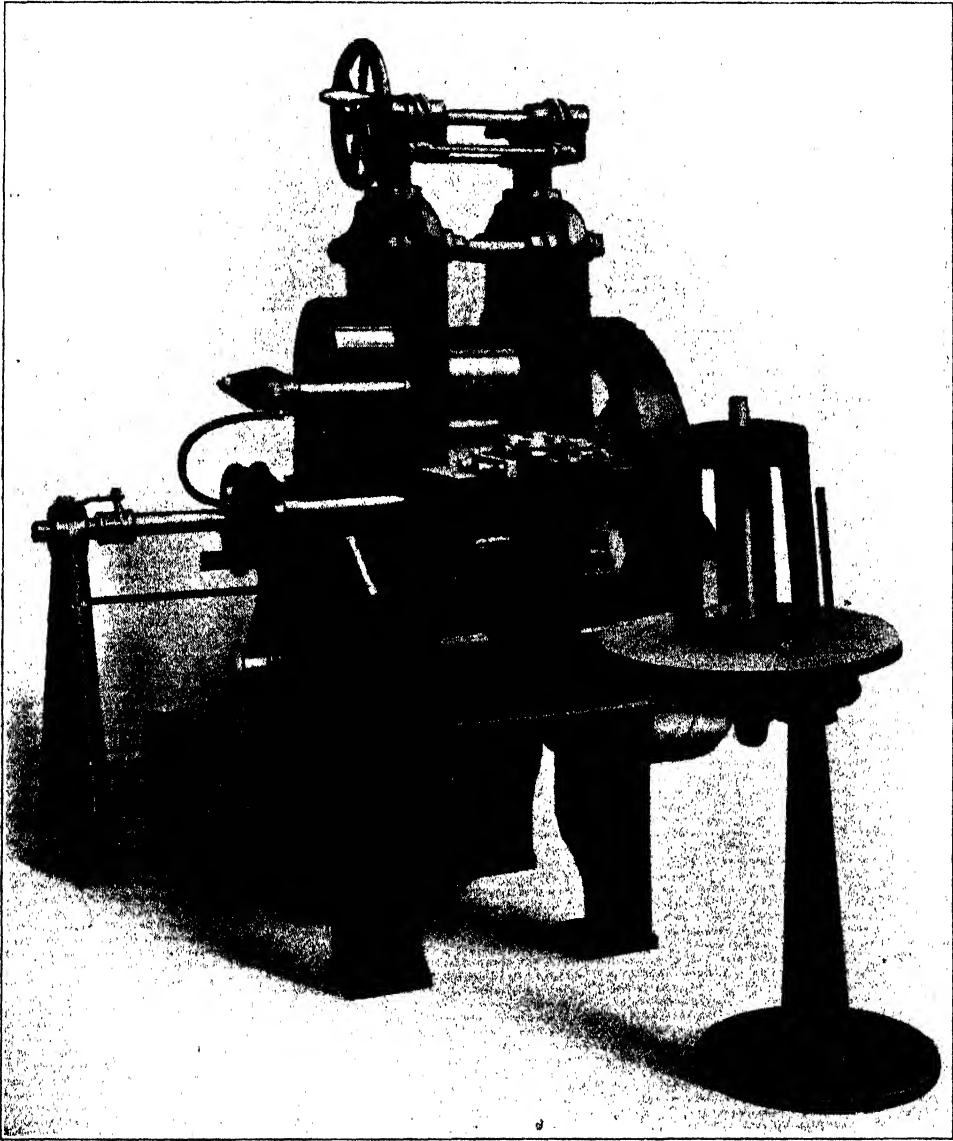

FIG. 165.—9 IN. \times 6 IN. WIRE FLATTENING MILL.

prevent excessive heating of the bearings or rolls a water supply is led directly on to the roll necks.

During the last ten to fifteen years great improvements have been made in the design and construction of special mills for wire flattening work, and the series of standard mills built by W. H. A. Robertson and Co., Limited, of Bedford, are good examples of modern practice in this class of machinery. These mills are made in standard sizes with rolls from 4 in. diameter to 12 in. diameter. Fig. 163 represents a typical example.

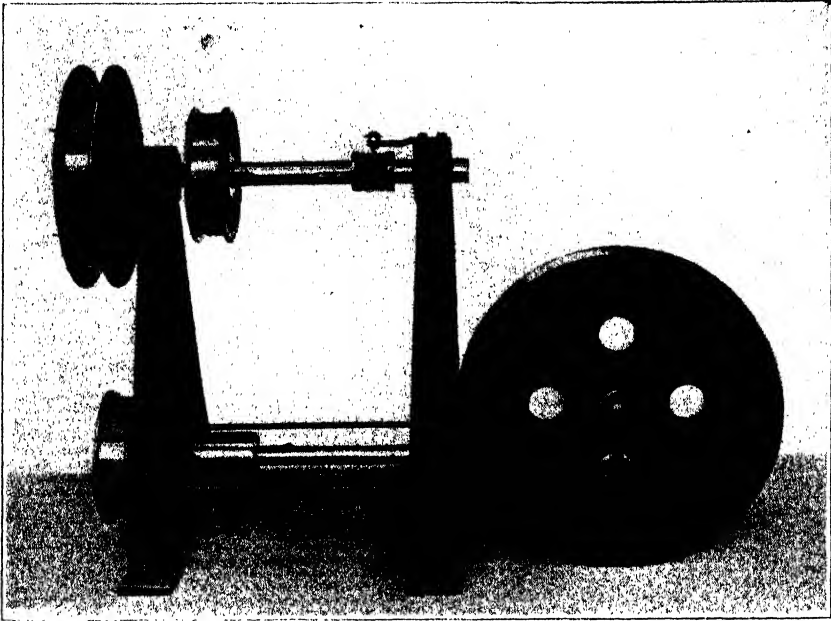

FIG. 166.—SINGLE COILING STAND.

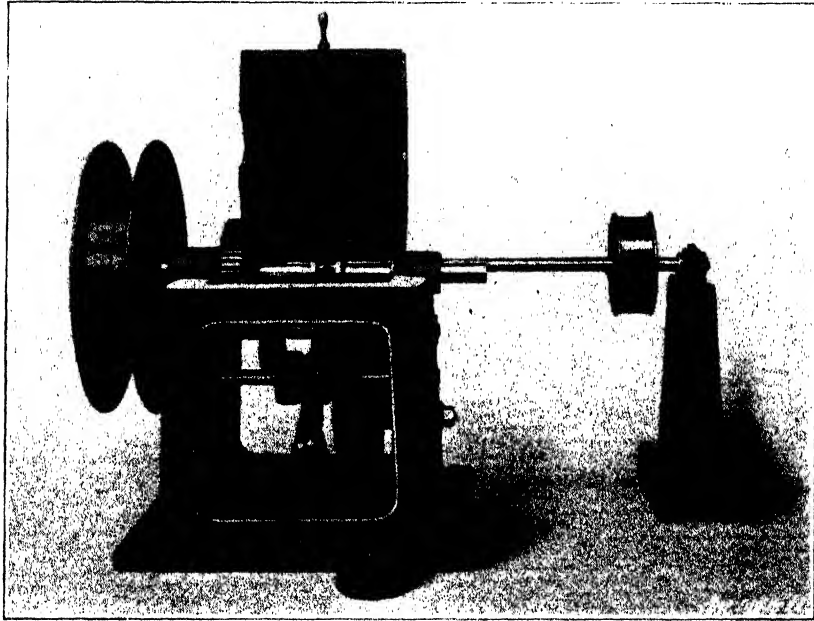

FIG. 167.—HEAVY COILING STAND.

It shows a Robertson wire flattening mill, with rolls 9 in. diameter, 6 in. face, intended for heavy work.

The hardened steel rolls are accurately ground to within 0.00025 in. of exact concentricity, and are carried in phosphor bronze bearings provided with an efficient lubricating system. The top roll is adjusted by steel screws, working in hammered iron

WIRE FLATTENING

nuts secured in the top of the roll frames, the two screws being simultaneously adjusted by a hand wheel at the side, through machine-cut worm gearing. The roll pinions are keyed to the roll spindles, and are made with a special form of tooth to provide for the necessary variation in the distance between the roll centres and to maintain at the same time accurate rolling contact.

The rolls are bored centrally, and are provided with water-cooling connections to maintain a moderate and uniform temperature. These water connections and fittings are seen in the left hand of Fig. 165. The mill is arranged for a belt drive, with fast and loose pulleys on the driving shaft, which is geared to the lower roll by a pair of machine-cut spur wheels.

In producing flattened wire, it is necessary that the finished material should be taken off by a special winder, as the wire must be drawn away from the rolls squarely, while it must be wound in even layers to prevent damage to its section. Part of the coiler can be seen in the background of Fig. 165, which also shows how the winder is driven, by belt, from a small pulley on the end of the main driving shaft. A general view of this coiler is given in Fig. 166. The wire is wound on to a double-flanged reel of the collapsible type, and the drum spindle is given a traversing motion, by means of a special double-threaded worm, in order to wind the strip uniformly between the flanges.

A more elaborate form of coiler is shown by Fig. 167. It is fitted with a cam-operated traverse, and is provided with adjustments both for the rate of traverse, to suit varying widths of strip, and for the total length of traverse, to suit different widths of coil. The rate of traverse is varied by means of change wheels, and the length of traverse by altering the position of the cam lever fulcrum. Usually, three holes are provided in the fulcrum bracket, giving three alternative positions for the pin on which the cam lever rocks.

Another important accessory is the straightening head, shown at the inlet to the rolls in Fig. 165. This device is necessary for straightening the round wire as it enters the rolls for the first flattening reduction and consists of five hardened steel grooved rollers, arranged as shown in Fig. 168. Two of the rollers are adjustable, while two guides with interchangeable steel bushes, to suit the diameter of the wire being used, are arranged at either end of the head. This straightening head is, of course, only required for the first pass. Even after the first pass, when the wire is already flattened, it is necessary to employ guides at the inlet to the rolls, to ensure the feed being truly at right angles to the axes of the rolls. A guide bracket for this purpose is shown to

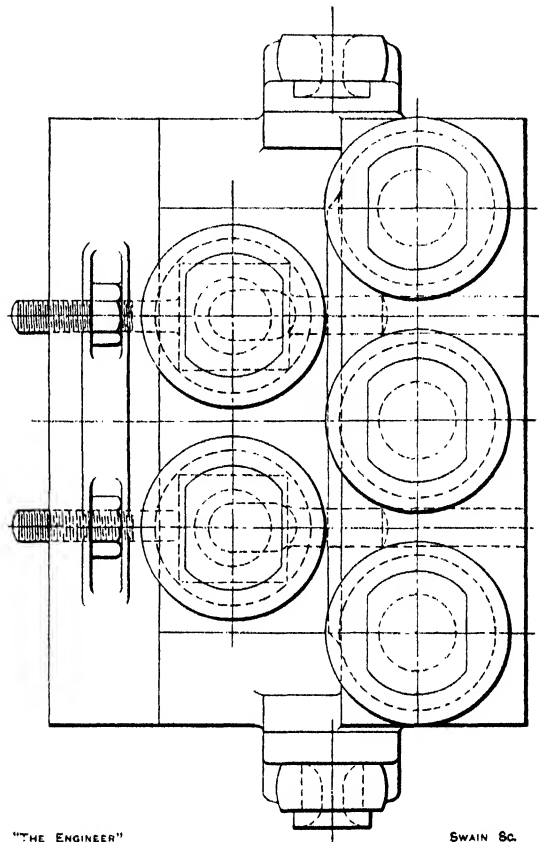

"THE ENGINEER"

SWAIN 80.

FIG. 168.—STRAIGHTENING HEAD.

the right of the straightening head in Fig. 165; when this guide is required the straightening device is easily removed from the supporting bracket. The guide bracket has a square hole, in which guide strips can be secured, and is slid into position in line with the pass through the rolls.

When a high degree of accuracy in width and a specially smooth and well-finished edge is required, the edging attachment shown in Fig. 169 is fitted to the mill. This mill is smaller than that already described, and has rolls 6 in. diameter by $2\frac{1}{2}$ in. face. The edging attachment consists of a pair of small hardened steel rolls, with their axes vertical, and provided with a series of shallow semi-circular or rectangular grooves, graduated to suit various thicknesses of strip.

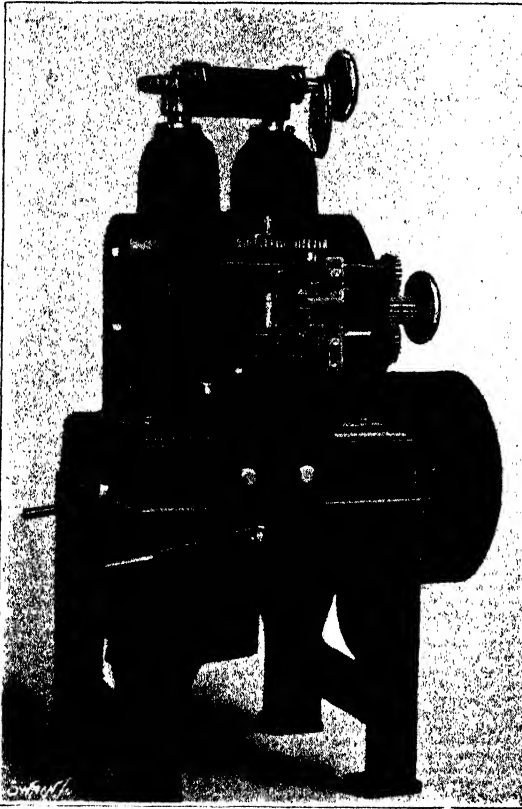

FIG. 169.—MILL WITH EDGING ROLLS.

The edging rolls are fitted on the inlet side of the main flattening rolls, and consequently cannot be employed until after the wire has been reduced to a flat section. Edging is generally accomplished during the last or last two passes, and as the action of the edging rolls tends to thicken the edges of the strip slightly the last pass through the flattening rolls must be light—just enough to equalise the thickness of the strip and to provide sufficient tension to draw the strip through the edging rolls.

In order to start the strip through the rolls for an edging pass, either the pressure on the edging rolls must be applied after the leading end of the strip has been gripped by the flattening rolls, which means scrapping a few inches of the leading end of the strip, or the strip must be fed through the edging rolls by turning them by means of a hand wheel keyed to the spindle of one of the vertical rolls. This hand wheel is not shown in Fig. 169, but is now always fitted and provides the best means of starting the pass. With power-driven edging rolls, such as those

fitted to the mill illustrated by Figs. 172 and 173 and described hereafter, this difficulty does not arise.

The edging rolls, of which a line drawing is given in Fig. 164, are not generally directly driven, but are geared together by machine-cut steel pinions. One roll is adjustable by means of a hand wheel and gearing to suit the width of strip required, and hardened strip guides, adjustable both vertically and horizontally, are fitted on the entry side.

Two further types of flattening mill are represented in Figs. 170 and 171. The first has rolls measuring 6 in. by $2\frac{1}{2}$ in., and has a separate spanner adjustment to the bearings for the top roll.

A still smaller pattern is shown in Fig. 171. In this case the rolls are 4 in. diameter by 3 in. face, and the machine is of exceptional interest, as it is provided with a special four-reel coiler, so that four wires can be rolled simultaneously. This method of

WIRE FLATTENING

increasing the rate of production is only suitable for very thin and narrow strip. Wire about 0.05 in. diameter can be flattened to 0.005 in. thick at one pass through these rolls at a rolling speed of 100 ft. per minute.

Heavier gauge wires require several passes to reduce them to thin strip, but modern wire-flattening mills are capable of taking very heavy reductions per pass. A Robertson mill, with rolls 6 in. diameter, has been tested on flattening $\frac{1}{4}$ in. diameter mild steel, and a 50 per cent. reduction in thickness was effected at each pass. The wire was reduced to 0.0156 in. thick, without annealing, in four passes, the first pass being from $\frac{1}{4}$ in. diameter to $\frac{1}{8}$ in. thick, the second from $\frac{1}{8}$ in. to $\frac{1}{16}$ in., and so on.

The maximum "pinch" or reduction in thickness at the first pass is limited by the power of the rolls to grip the metal, which depends on the roll diameter. About $\frac{1}{8}$ in. reduction in thickness is the limit for rolls of 6 in. diameter, unless the end of the wire is flattened before it is inserted between the rolls.

The best relation of roll diameter to size of wire flattened naturally depends on many factors, such as the total reduction required, the maximum pinch, and the degree of accuracy demanded. Table II. indicates the maximum size of wire which can be conveniently flattened between rolls of standard dimensions, taking reasonably heavy reductions.

The power absorbed in wire flattening varies with the size of the rolls, rolling speed, reduction taken, and the nature of the metal rolled, and consequently cannot be stated generally. Approximate figures for the power required are, however, given in Table II., and are based on a maximum rolling speed of 100 ft. per minute.

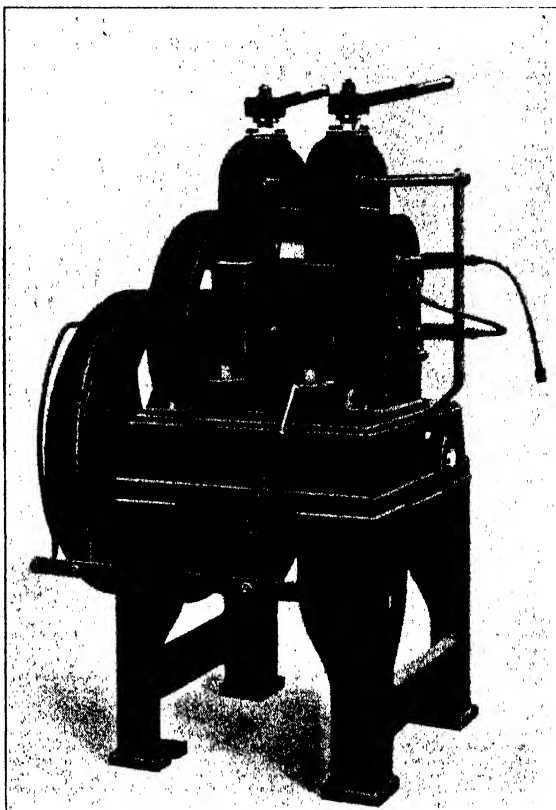

FIG. 170.—MILL WITH SEPARATE ADJUSTMENT FOR BEARINGS.

Roll diameter.	Size of wire.	Horse-power.
4 in.	8 S.W.G.	6
6 in.	4 S.W.G.	10
8 in.	$\frac{5}{16}$ in.	12
9 in.	$\frac{3}{8}$ in.	15
10 in.	$\frac{1}{2}$ in.	18

At the present time practice tends towards employing rolls of larger diameter than used previously for any particular size of wire, for not only is it possible to take heavier reductions, thereby reducing the number of passes required, but on account of the

BRITISH WIRE-DRAWING AND WIRE-WORKING MACHINERY

greater rigidity of the heavier mill a higher degree of accuracy is obtained in the finished product. Rolls 9 in. and 10 in. diameter are now very generally in use, and for flattening rod of large diameter heavy mills with rolls 12 in. diameter have been installed.

As will be readily understood, any spring in the rolls or stretch in the roll frames will, in conjunction with vibration, cause the strip to be wavy—that is, varying in both thickness and width.

There is also the important question of rolling speeds. Generally 70 ft. to 80 ft. per minute is adopted for rolls on this class of work, although 100 ft. per minute and even higher speeds are not uncommon. The disadvantage of high speeds is the vibration that they introduce, which results in a loss of accuracy and uniformity in the thickness

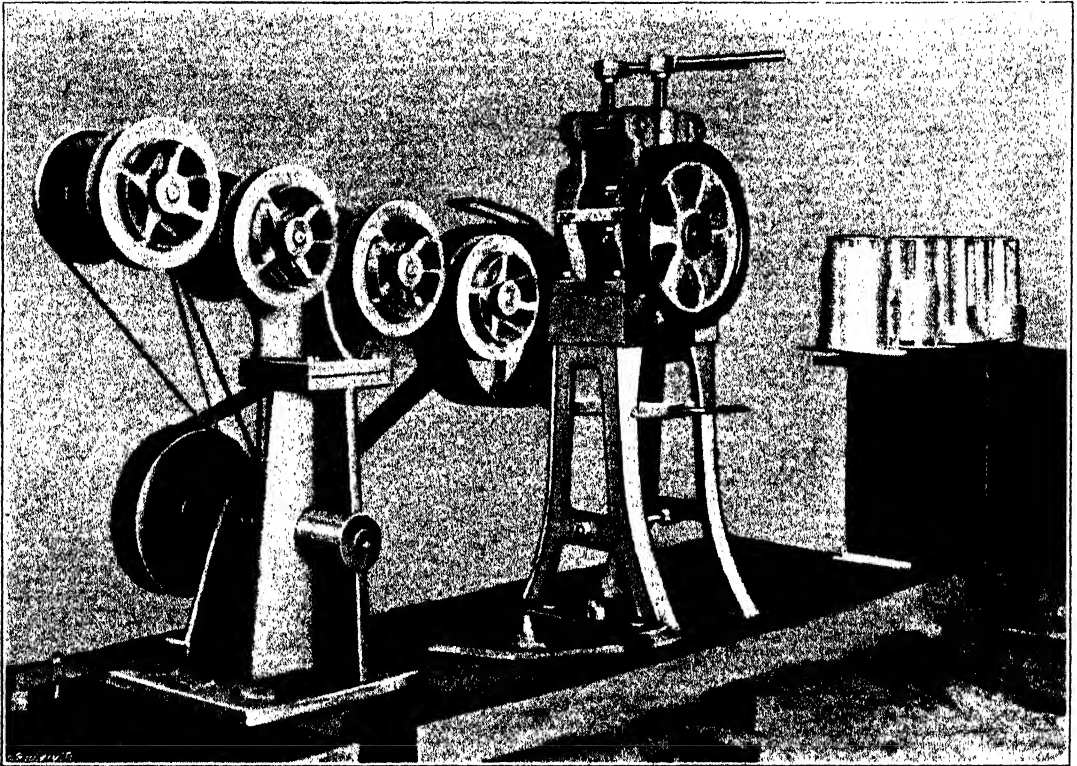

FIG. 171.—SMALL FLATTENING MILL FOR FOUR WIRES.

of the rolled strip, while the heating of the rolls and their bearings also causes trouble. Both these defects may be eliminated by employing rolls amply large for the dimensions of wire rolled, as for the same peripheral velocity the speed of rotation is reduced, with a corresponding reduction in vibration. The greater bearing area and increased area of radiation surfaces also prevent an excessive rise in the temperature of the bearings.

In all cold rolling mills the problem of maintaining a reasonably low bearing temperature is a serious one, on account of the heavy loads which the roll bearings are required to carry, and with heavy pressure any increase in speed is naturally likely to cause bearing trouble, besides which the progressive heating of the rolls results in a variation in thickness of the rolled strip.

In order to give some idea of the magnitude of the pressure on roll bearings in wire

WIRE FLATTENING

flattening, it may be mentioned that the mill with 6 in. diameter rolls previously described, when flattening mild steel wire from $\frac{1}{4}$ in. diameter to strip $\frac{1}{8}$ in. thick at one pass, would be called upon to impose a pressure of about 6 tons on the metal in

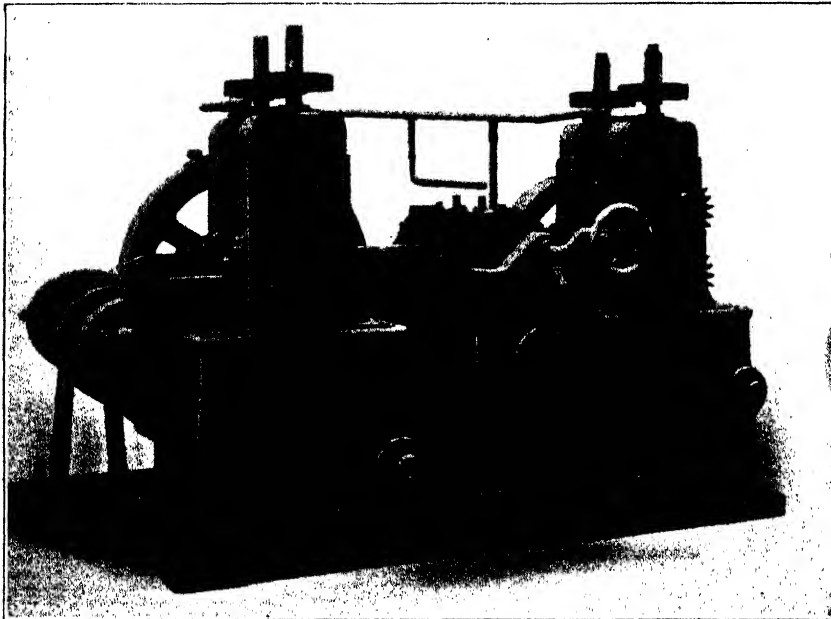
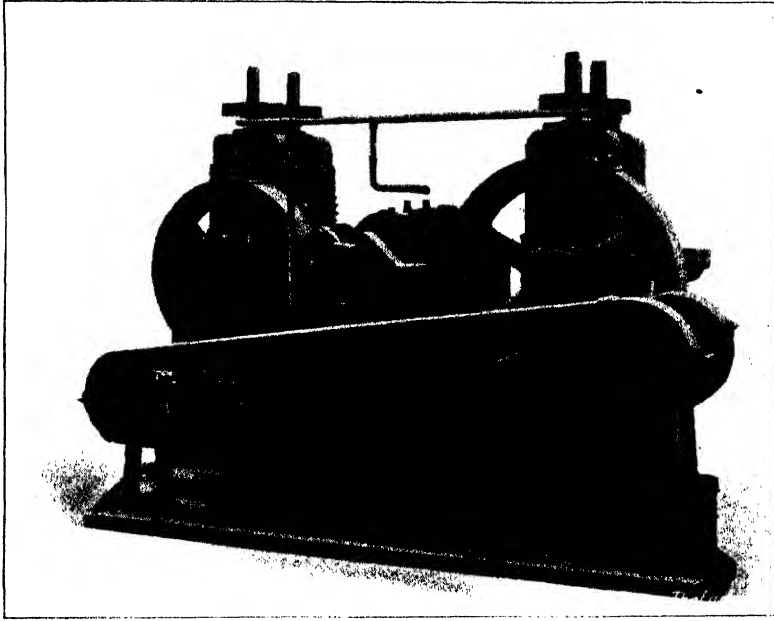

FIGS. 172 AND 173.—TANDEM TWO-PASS MILL WITH EDGING ROLLS.

contact with the rolls. This load must, of course, be carried by the two bearings supporting each roll.

To obtain a reasonable output from a wire-flattening mill it is obviously necessary

BRITISH WIRE-DRAWING AND WIRE-WORKING MACHINERY

to make as heavy reductions as possible at every pass, and also to roll at the highest possible speed, for, with the comparatively small dimensions of strip produced by such mills, the weight per foot of material rolled is correspondingly small, and a step in advance in this direction has been effected, within recent times, by improving methods of lubrication for the roll bearings and by internal water cooling of the rolls themselves, which has permitted higher speeds without detriment to the quality and accuracy of the finished product.

Another modern development, just coming into vogue in this country, for wire flattening and strip rolling is the tandem mill. Taking, for example, the reduction

from $\frac{1}{4}$ in. diameter rod to the $\frac{1}{64}$ in. thick flat previously mentioned, if four reductions are required, the material must be passed four times through the rolls, and for each pass it has to be coiled, removed from the coiler drum, and placed on a swift or unwinding reel for the next pass. The total net rolling time per ton for such a process may be some forty-eight hours. If, by arranging two mills with their rolls in line with one another, the strip can be passed through the two pairs of rolls simultaneously, and coiled only after the second pass, the total reduction can be accomplished in the equivalent of two passes, and the total rolling time may be reduced to about seventeen hours. There is also the saving in handling the coils twice between passes. Incidentally, with the tandem mill the output is further increased, as compared with the single pass mill, as the finishing rolls have necessarily to run at a higher speed than that of the roughing rolls, on account of the extension of the material. As in all continuous rolling, means must be provided for adjusting the speed ratio between the two pairs of rolls. Mills operating on the tandem principle are

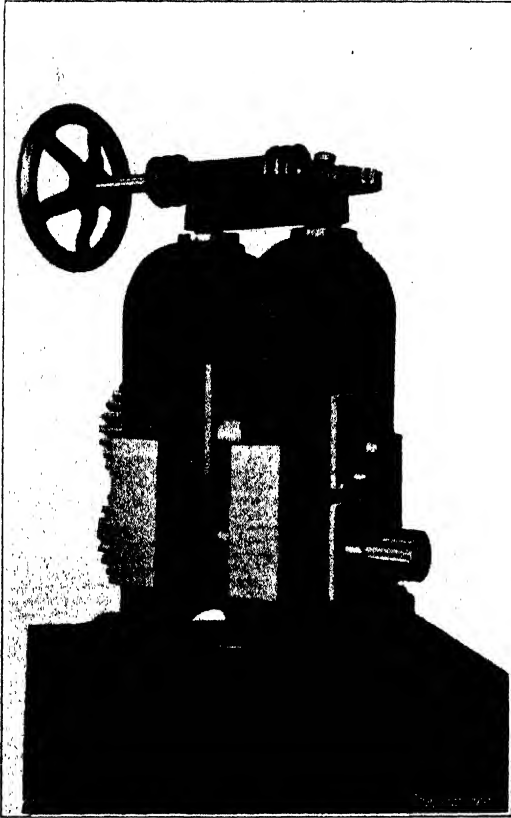

FIG. 174.—MILL FITTED WITH ROLLER BEARINGS.

frequently employed in America, but have only very recently been introduced into this country.

A mill of this type built by Messrs. Robertson to designs furnished by the Torrington Manufacturing Company, Torrington, Connecticut, U.S.A., with which firm the Bedford Company is associated, is illustrated by Figs. 172 and 173. This mill is really three mills in tandem, for besides the main roughing and finishing rolls, a pair of power-driven edging rolls is mounted between the two main roll stands, so that at one pass the wire is flattened through two reductions, and is also edged. For many classes of flattened wire this single process is sufficient to finish the material.

The machine, it will be seen, is self-contained on one bed-plate. Each pair of rolls is driven by machine-cut spur and chain gearing from a main driving shaft, which may itself be driven either by belt, from line shafting, or by a pitch chain from an

WIRE FLATTENING

electric motor. The driving gear is best illustrated by Fig. 172, in which the main shaft is shown on the right. On this shaft there is mounted any proper means of driving, such as a belt pulley, chain sprocket or gear wheel. The long chain drive shown prominently in Fig. 172 connects the main shaft with the driving shaft geared to the finishing rolls at the left-hand end of the mill; while the shorter, inner, inclined chain drive transmits the power to the edging rolls.

Neat welded steel guards are provided to cover all the chain and spur gearing.

The roughing rolls are directly geared to the main shaft, but the edging rolls and the finishing rolls are driven through multiple plate friction clutches, which may be adjusted by means of the hand wheels, that are seen projecting from the bed-plate in Fig. 173. In this way the speed of these two pairs of rolls may be varied, by allowing more or less slip in the clutches, thereby providing for the elongation of the rolled metal. Sufficient variation in speed can be obtained to allow for the elongation resulting from any common reduction in thickness.

The edging rolls are driven by bevel gearing, which is enclosed in a gear-box that provides effective lubrication. The two rolls are adjusted in the horizontal direction to suit the width of strip rolled by a hand wheel geared to screws which adjust both rolls simultaneously. The edging rolls themselves are of hardened steel, and are provided with several grooves to suit different gauges of strip. They have means of vertical adjustment, so that any one of the grooves may be brought into line with the metal as it passes from the roughing to the finishing rolls.

Adjustable guides at the entry to the roughing rolls and between the finishing and edging rolls are fitted. The bed-plate is designed to form a reservoir for waste oil and to prevent oil or other lubricant from flowing on to the mill floor and foundation. A chain-driven oil pump is fitted to supply oil to the roll bearings and to the rolled strip as it enters the rolls.

The speed of the finishing rolls may be as high as 180 ft. per minute, so that the production from such a mill is very considerable. This type of mill is built with rolls 8 in. or 10 in. diameter, and is generally provided with a coiler of the type shown in Fig. 167, which may be belt or chain driven from the mill.

Another recent improvement introduced by Messrs. Robertson in the design of wire-flattening and strip rolling mills is the fitting of roller bearings to the necks of the rolls. After consultation with the Skefko Ball Bearing Company, which has co-operated in the necessary experimental work, the S.K.F. self-aligning double-row roller bearing has been adopted by them, and the heavy losses in bearing friction have been considerably reduced. A saving of 30 to 50 per cent. of the power absorbed by a mill has, it is claimed, been obtained in this way. Fig. 174 shows a stand of 6 in. flattening rolls fitted with roller bearings of this type.

CHAPTER XX

MISCELLANEOUS MACHINES

THE foregoing chapters have described most of the principal British machines employed in the wire industry of this country, but there are, specially round about Birmingham, many factories where wire is worked up into a host of useful articles, by means of quite special machinery. Many of these industries have been built up on the ingenuity of some member of the firm in devising appliances to produce the desired result, and only naturally these people do not always care to disclose their methods. The majority of these special machines are, however, very simple, and comprise a series of cam-operated tools or fingers working in conjunction with formers, round which the wire is bent. Some of them also are very old, but little use would be served in describing these machines, even if the owners were willing that it should be done, as their application is limited, and every engineer will appreciate that by arranging for the movement of the tools in several planes, practically any shape of wire article can be produced.

There are, however, several minor wire-working machines still to be dealt with, and they can be appropriately grouped together. The first of them is illustrative of the bending process just referred to.

PAPER CLIPS

The machine illustrated in Fig. 177, which is by Mr. E. White, of Redditch, is used primarily for making the familiar clips used for holding sheets of correspondence together, and its action can be followed with the assistance of the diagram, Fig. 175.

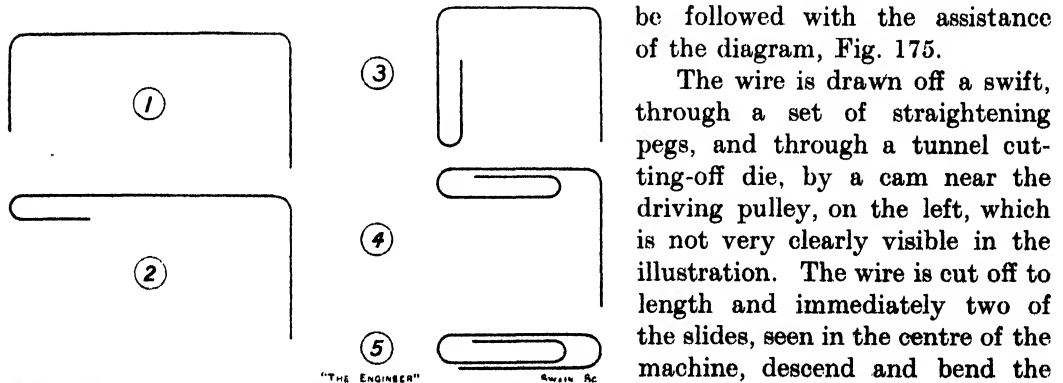

FIG. 175.—STAGES IN THE MAKING OF PAPER CLIPS.

The wire is drawn off a swift, through a set of straightening pegs, and through a tunnel cutting-off die, by a cam near the driving pulley, on the left, which is not very clearly visible in the illustration. The wire is cut off to length and immediately two of the slides, seen in the centre of the machine, descend and bend the wire into the form shown in (1), Fig. 175, round a pair of projecting pegs. The second operation is to bend the left-hand end round again, by means of a horizontally moving tool, as shown at (2), Fig. 175. This slide then recedes and another of the vertical tools comes down to make the bend shown by (3). In the interval, the peg on the left, round which the wire was first bent, has, of course, receded. Another movement of the left horizontal slide produces the formation shown at (4), and a stroke of the corresponding horizontal slide on the right completes the coiling of the clip to the shape shown at (5).

MISCELLANEOUS MACHINES

In some cases the clip is then considered as being complete, and the pegs, round which it has been formed, recede, so that it may fall clear. The better class of clips, however, have the end of the first loop bent slightly out of plane, to give the clip a free lead on the edge of the paper, and this bend is effected by a transversely moving slide in the front of the machine, which can be plainly seen in Fig. 177, and which completes its stroke just before the bending pegs release the clip.

All these operations are effected by means of cams on the single main shaft running across the machine, and the precise form of the clip is naturally dependent upon the shape of the tools and the sequence of their operation. The rate of production is some ninety clips per minute.

A simple little machine for much the same purpose, but which is worked by hand, is represented by the engraving, Fig. 176. In this case the principal forming tool is

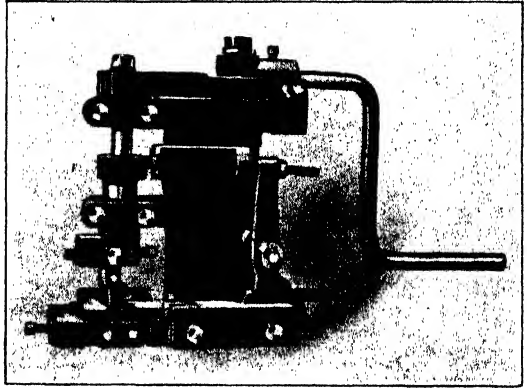

FIG. 176.—HAND-BOWING MACHINE.

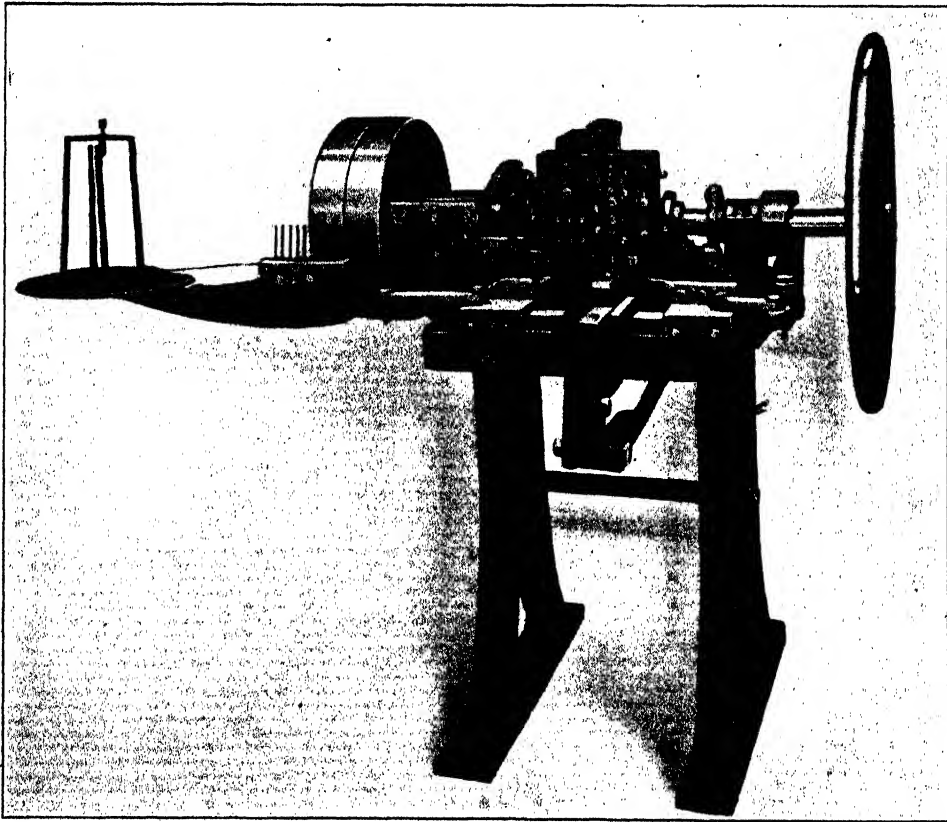

FIG. 177.—PAPER-CLIP MAKING MACHINE—E. WHITE.

BRITISH WIRE-DRAWING AND WIRE-WORKING MACHINERY

carried by the vertical spindle, rotated by a hand lever through toothed gears. The wire is bent by this tool round a former fixed on the base, and a subsidiary slide, worked by a cam on the vertical spindle, provides an opportunity for making compound bends. Such objects as skewers, button hooks and so forth are commonly produced on machines of this type, which are made to handle wire up to so large as No. 6 gauge.

HAIR-PIN MACHINES

The actual operation of bending hair-pins is really a very simple matter, as it is effected by merely pulling a length of wire by the middle between two stops, so that the two ends are folded together, but the machine used for the purpose is of a fairly complicated nature, as it has to perform several other operations. That shown in Fig. 178, which is capable of producing some eighty pins a minute, is made by Mr. E. White, of Redditch.

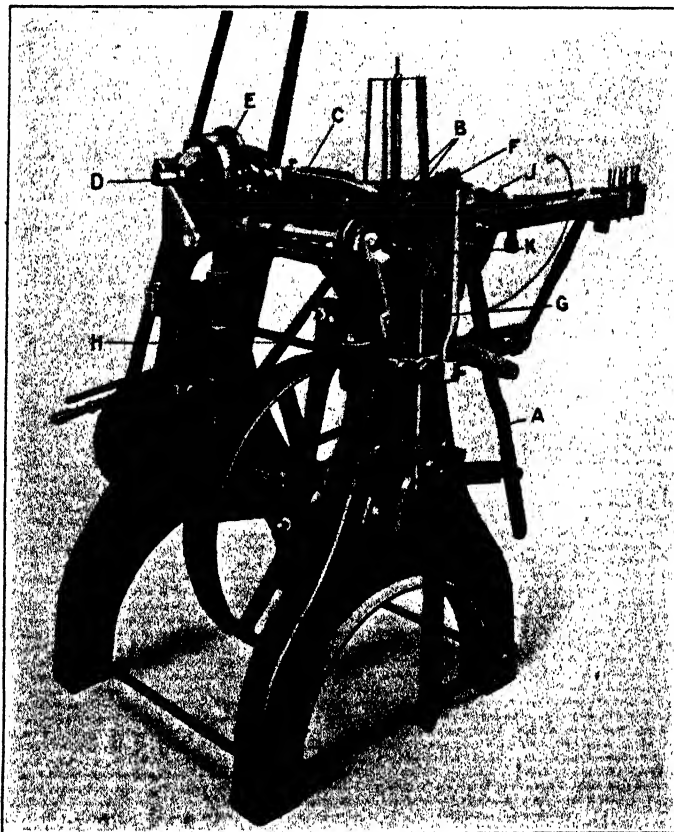

FIG. 178.—HAIRPIN-MAKING MACHINE—E. WHITE.

The wire is taken from a coil on a swift and drawn through a set of pegs, which can be seen on the right in the illustration, to straighten it. The feed is effected by the lever A, which is driven off the bottom shaft of the machine and is slotted at the end so that the length of wire fed forward at each stroke can be altered to suit the size of pin required. The straightened wire is projected across the table of the machine and under two pads B B, which are pressed down to grip it by means of the lever C, and

a cam on the transverse shaft D at the end of the machine. As soon as the wire is held by the pads, it is cut off by a tool operated by a cam on the back end of the shaft D.

The pads B B are then moved forward by the cam E, which bears against a roller on the slide carrying the fulcrum of the lever C. The consequence is that the wires are rolled on their own axes as they move forward along the table, and as they go they travel across the faces of a pair of mills, one of which is shown at F in Fig. 178—the other is, of course, hidden behind the machine. These mills have file-cut teeth, similar to those used in ordinary pin making, and are driven at a very high speed by belts from the bottom shaft. The bearings of the mills are fitted in adjustable brackets, so that they can be set to suit the length of pin being made. The angle at which the wires are presented to the mills is such that the arris left by the cutting-off tools is removed and a blunt conical point is produced. There is, of course, no necessity to give the wires a fine point.

The wires continue to roll forward and finally drop over the end of the table on to guides. At this moment the plunger G is pulled down by the crank on the end of the bottom shaft. A nib on the plunger engages the wire at the centre and pulls it down between the two guides, so that the wire goes downward with the two ends pointing up and the bend is formed about the rounded face of the nib. A plain hair-pin is thus formed, but nowadays they are almost always made with crimps or waves to increase their holding properties. These crimps are produced by a pair of levers, one of which is shown at H, that rock forward appropriately formed tools at J. These tools pinch the wire against the correspondingly formed sides of the bending nib. The crimps would prevent the completed pin from falling clear of the machine, so the bending tool is arranged to be retracted into the plunger G, when it has performed its functions, and for this purpose a little trigger is mounted on the upright rod K, while the cam and lever seen just below the letter D withdraw the tool round which the pin is bent. The pins are then free to fall out, and are delivered by the shoot below.

FLATTENING ROLLS

Among the firms which have specialised in the production of rolls for flattening wire there is Sir W. G. Armstrong Whitworth and Co., of Openshaw, Manchester. They contend that the principal requirements of a satisfactory roll are as follows:— (1) The rolling surfaces must be “glass-hard” and of a mirror-like finish; (2) there must be an entire absence of even the most minute specks or scratches on the surfaces; (3) a pair of rolls must be absolutely identical in diameter within a few ten-thousandths of an inch, as they are geared together positively by equal wheels; (4) the rolling surfaces must be absolutely circular and concentric with the axes of rotation of the spindles; (5) the rolling surfaces must maintain straight line contact.

If condition (1) is not fulfilled, the rolls will have only a short life and soon become scored or grooved. In the case of condition (2) the presence of a minute speck or cavity on the surface means that a corresponding slight projection or point will be raised on the surface of the wire, and this is fatal. If conditions (3) and (4) are not fulfilled, the rolls will produce wire of varying thickness. Deviation from condition (5) results in wire of irregular section.

In many factories the pairs of rolls are geared together with ordinary straight tooth spur wheels, and if these gears are not machine cut and made very accurately an irregular action is imparted to the rolls, which is reflected in an irregularity in the

BRITISH WIRE-DRAWING AND WIRE-WORKING MACHINERY

thickness of the wire produced. Messrs. Armstrong have, however, recently designed a pair of double-helical gears—as shown in Fig. 179—which overcomes this difficulty. One of the wheels is of steel and the other bronze, and the centres can be displaced

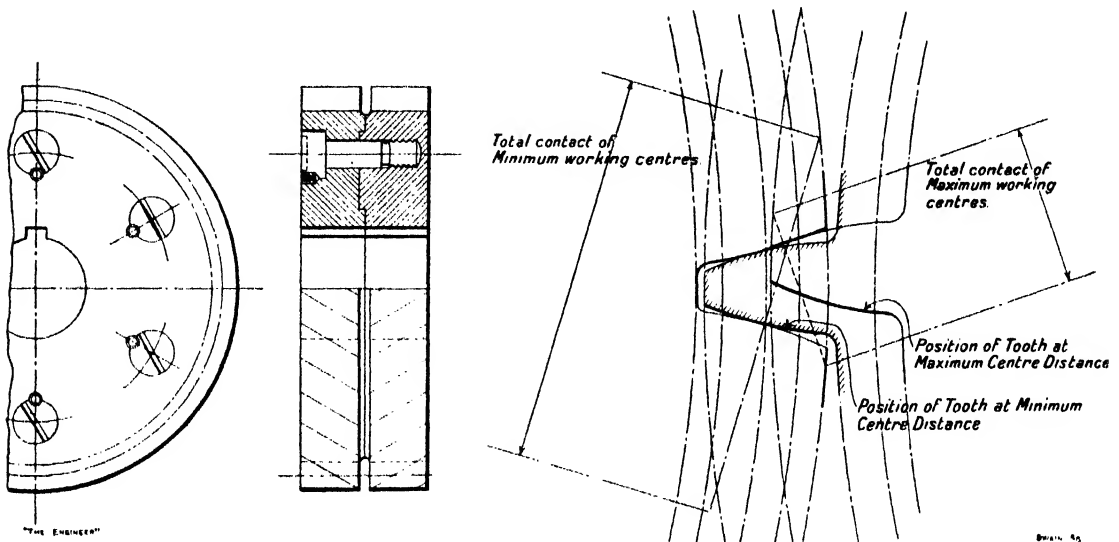

FIG. 179.— DOUBLE HELICAL GEAR FOR WIRE-FLATTENING MACHINES.

considerably in the process of adjusting the rolls for the thickness of the wire, while maintaining continuous tooth contact, so that a very smooth movement is given to the rolls, and the thickness of the wire is kept constant.

SPRING MAKING

The manufacture of coiled springs consumes very large quantities of wire, and, although the process is very simple, this account would be incomplete without some reference to the subject.

One of the largest firms specialising in the production of springs is Herbert Terry and Sons, of Redditch, and the two views given in Figs. 180 and 181 were taken in their shops. Helical springs are coiled on a simple mandrel chucked in a lathe. The wire is led through a guide fixed in the slide rest and slipped under a stop on the mandrel. The pitch of the coil is determined by the travel of the slide rest, which is worked by an ordinary lead screw; but in the case of springs in which some coils are more open than the others, specially shaped gear wheels are used in the train of gears driving the lead screw. Heavy springs are generally made individually, and cut off one at a time; but lighter sorts are often made several together and separated afterwards. In either case the ends of the springs have often to be ground to make them square with the axis, and this grinding is done by hand on face wheels.

Some light springs are required in such large quantities that the method just described would be too slow and an overhung mandrel is then used. The wire is coiled on at the headstock end, and when the mandrel is filled the spring is released and pushed off into a pipe. The winding is continued and a spring is thus produced which may be 150 ft. or so long. The pipe which accommodates the completed part of the spring is generally led below the floor and may make a complete circuit of the shop below the boards. The spring is, of course, subsequently cut up into the required lengths.

The peculiarly shaped springs, with a waist in the centre and wide flared ends,

MISCELLANEOUS MACHINES

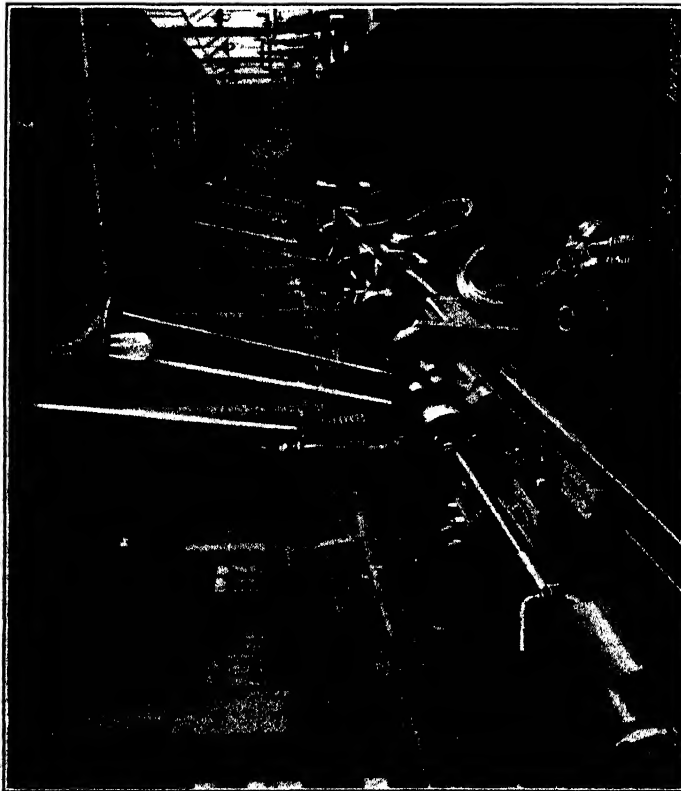

Figs. 180 AND 181.--SPRING-COILING SHOPS OF HERBERT TERRY AND SONS.

BRITISH WIRE-DRAWING AND WIRE-WORKING MACHINERY

used by upholsterers are made by a rolling process. The wire is passed between three grooved rolls, set at a slight angle to give the pitch to the spring. The centre roll is mounted in a slide and is moved up and down this slide by a cam, so that the curvature given to the wire is less at the beginning and end than it is at the centre of the spring. In some shops the end of the wire is "knotted" round the previous turn by a machine, but more generally this operation is done by hand in a simple press, which first bends up the end at right angles and then folds it over the wire.

WIRE MATTRESSES

The production of the common wire spring mattress involves the consumption of a large amount of high-class steel wire every year, and is carried out by quite a large number of firms; but it is a peculiar thing that it is very difficult to get any precise details as to the construction of the machines involved. This reticence is all the more remarkable in view of the fact that the mechanism involved is extremely simple in principle. The arrangement can, however, be described in a very few words.

The wire, which must incidentally have been drawn to the exact temper necessary, is pushed by a pair of feed rolls into a spirally (helically) shaped tunnel. This tunnel is formed by cutting a groove round a spindle and surrounding it by a closely fitting sleeve. The sleeve is free to rotate, so that the wire is retarded as little as possible, and the end thrust on the sleeve is sometimes taken by a ball washer. The spindle and sleeve are both surrounded by a casing which is brought to a flat taper so that it may project right up between the feed rolls and prevent the wire from "spilling" out as it is pushed forward.

The pitch of the spiral groove in the spindle starts very steeply and is gradually reduced, with the result that the wire emerges from the device, commonly known as a "giraffe," in the form of a rotating spiral.

When sufficient spiral has been made for the length of a mattress, the feed is stopped and the wire cut off, generally by a treadle operated shear. Sometimes the feed is stopped by throwing off the driving belt, but in other machines the two feed rolls are separated so that they lose their grip on the wire.

The spiral formed is projected along a table behind the machine, and as soon as it is cut off from the stock it is pulled sideways by the attendant. Then another spiral is made, and as its end worms forward it meshes into the coils of the previous spiral. The process is repeated until sufficient width has been produced to make a mattress. There are a few machines in which the transverse feed of the spirals is effected automatically, but they do not appear to be very popular on account of the great variety of sizes of mattress required by the trade and the consequent necessity for adjusting the mechanism.

It is common for each spiral to be formed by more than one wire and then the grooves in the spindle and feed rolls have, naturally, to be correspondingly enlarged. Up to within quite recent times it has been the practice to provide the extra accommodation for additional wires by widening the grooves in the feed rolls; but the arrangement had the objection that even the slightest variation in the gauge of the wires resulted in one or the other not being gripped properly and fed forward. Mr. Herman Kershaw, of Liversedge, Yorks., has, however, overcome the difficulty by the simple expedient of piling the wires, one on the top of the other, in deep grooves. Then not only does the law of averages help matters, but the wires grip one another and consequently all are positively fed forward. Incidentally, it is noteworthy that the manufacture of these feed rolls is a highly skilled art, as their conditions of service are very severe.

MISCELLANEOUS MACHINES

By developing the principle of the "giraffe" in the way of varying the cross-sectional shape of the spindle and giving it a positive rotary drive, the form of the spiral may be adapted to a variety of purposes, such, for instance, as the production of the flat meshed fencing which looks rather like a wire doormat, but the majority of the machines used in that industry are of German origin and consequently do not come under our present purview.

CONCLUSION

In conclusion it should be pointed out that, throughout, attention has been concentrated on British-made machinery, to the exclusion of foreign, although many ingenious wire-working machines have been developed abroad and have a certain vogue in this country, but it is obvious that if equally good plant of British manufacture is available, it must be our policy to advocate it rather than the foreign product.

Yet the British wire industry cannot afford to shut its eyes to the developments which are taking place in other countries, and it is noteworthy that strenuous efforts are being made, specially in America, to increase the speeds at which wire can be drawn. Thus the Western Electric Company, of New York, has recently been experimenting with a form of die, certainly not entirely novel, but which, it is claimed, permits wire to be drawn at speeds as high as 2,500 ft. a minute. Even this high speed is eclipsed by Messrs. L. and P. Bréguet, of Geneva, who claim to be able to draw wire at the rate of 100 kiloms. per hour, or, say, 5,500 ft. per minute. In neither case is the gauge of the wire disclosed, but it must be very fine, and it is possible that the time lost through breakages may counterbalance that saved by the increased speed.

In the drawing of heavy and medium gauge wire the British makers are pre-eminent, a fact which is, no doubt, largely to be accounted for by the long association of families with the industry and the consequent development of that faculty which is generally ascribed to heredity. It is noteworthy in this connection, that wire-drawing is principally confined to a few circumscribed localities, such as Birmingham, Warrington and the Spenn Valley of Yorkshire, with the result that the people of those places grow up under the influence of the industry.

In other directions, however, Continental inventors have done much towards the development of the wire-working industry. Thus some of the French nail-making machines are really most ingenious, while the Germans have elaborated plant for making wire fencing to a high degree of excellence, and, with the English exception already mentioned, diamond dies are exclusively made on the Continent.



INDEX

	PAGE		PAGE
ANNEALING	11	Continuous wire-drawing machine, two-	
Annealing furnaces	12	hole	38, 39
Annealing pots	13	Continuous wire-drawing machine, vertical	
		roll	42
BAKING	15	Continuous wire-drawing machine, very	
Barbed wire	67, 124	fine wire	46
Barbed wire making machines	86	Cooke and Co., Ltd., Wm.	2
Battering dies	21	Copper coating	15, 83, 86
Battering machines, die	22	Crimping machine	98
Battering machines, pneumatic die	25	Cutting-off machine for heavy wire	51
Bedson George	7, 59	Cutting-off mechanism	51
Belgian looping rod mill	2	Cutting-off and straightening machines	49
Billets, wire rod, size of	2, 9, 62, 63		
Blocks, wire-drawing	27	DIES, diamond	26
Blocks, wire-drawing, doubled-sided	32	Dies, maintenance of	22
Blocks, wire-drawing, internal geared	30	Dies, steel breaking-down	20
Blocks, wire-drawing, single	27, 28, 30	Drawing-in gear	28
Blocks, wire-drawing, steel-framed	29	Drifts, die	21
Bobbin winding by hand	105		
Bobbin-winding machines	105	EDGING rolls	172
Bowing machine, hand	179	Electric cable making	104
Bradford ironworks	59		
Brittle of pickling	15	FACTORIES, lay-out of	16
Browning	15	Fine wires	11, 26, 46
Brunton, J. D.	11	Flattening mill gears	182
		Flattening rolls	181
CABLE making, electric	104	Flattening wire	88, 166
Chains, curb	160		
Chains, jack	162	GALVANISING frame, wire	70
Chains, knotted	162	Galvanising wire	70
Chains, trace	156	Gauze, wire	90
Clip, paper, making machines	178	Giraffe, the	184
Closing machines, cable	112, 118	Glidden barbed wire	124
Cloth, wire	90		
Coiling stands	171	HAIR-PIN machines	180
Coiling very fine wire	47	Harvey Siemens furnace	7
Continuous wire-drawing machines	36	Historical	1
Continuous wire-drawing machine, belt-		Hughes, Mr.	15
driven	43		
Continuous wire-drawing machine, chain-		IOWA barbed wire	124, 128
driven	44		
Continuous wire-drawing machine, fine		JOHNSON, Dr. F.	11
wire	46		
Continuous wire-drawing machine, four-		LACQUERING	15
hole	37	Laying-up machine, six-core	120
Continuous wire-drawing machine, nine-		Liming	15
hole	40		
Continuous wire-drawing machine, tandem	42		
Continuous wire-rod mill, gear-driven	62		
Continuous wire-rod mill, the first	59		
Continuous wire-drawing machine, three-			
hole	36, 38		

INDEX

	PAGE		PAGE
Longmuir, P.	11	Scrap-bundling machine	78
Looms, automatic wire	96	Selvedge of woven wire	98
Looms, semi-automatic wire	97	Shuttle for wire loom	97
Looping rod mill, Belgian	2	Skimming machine, needle	144
Lubricants for wire drawing	30, 41	Smith and Co., E. and A.	18
		Sorbite	13
MATTRESSES, wire	184	Speed of chain-making machine	157
		Speed of flattening mills	174
NAIL-MAKING machines, wire	131	Speed of hair-pin machines	180
Nails, wire	89, 131	Speed of needle-pointing	143
Needle-eye stamping machine	144	Speed of pin-making machines	137
Needle-making	141	Speed of rod mills	59, 63
Needle-point grinding	143	Speed of safety-pin machine	154
Netting, galvanising wire	78, 89	Speed of wire drawing	185
Netting, tight winding wire	78	Speeds, fine wire drawing	46
Netting, wire	72, 86	Spinner, straightening	49
		Spring making	182
OUTPUT of rod mills	7, 10	Straightener, roll type of	50
		Straightening and cutting-off machines	49
PAPER-clip machines	178	Straightening and cutting-off machine, continuous	52
Patenting	13, 68	Straightening and cutting-off machine, high-speed	57
Patenting frame, wire	68	Straightening and cutting-off machine, needle	57
Patenting frame, wire, with variable speed drive	70	Straightening and cutting-off machine, roll feed	56
Patenting furnaces	68	Straightening and cutting-off machine, small	57
Pickling	15, 73	Straightening and cutting-off machine, two-wire	52
Pin-making machines	136	Straightening needle-wire	141
Pin-sticking machine	139	Stranding machines	106, 117
Pointing furnace	16, 18	Stringing-up machine	41, 43
Pointing machine	17, 19	Swaging machine, rotary	18
Pointing rolls	15, 18		
Power for wire mills	17, 38	TEMPERING	15
Power required for flattening wire	173	Templeborough rolling mill	2, 7
Punch-grinding machine	21	Tensile strength	11
Punches, die	21	Thornton, Mr. A.	1
		Titely, Mr.	15
RIVET-MAKING machines	133		
Rod mills, continuous wire	7, 59	UPHOLSTERY springs	183
Rods, brass wire	2		
Rods, steel wire	2	WARP beams	92, 103
Rolled gold wire	156	Warp beam winder	93
Rolls, flattening	181	Wire-drawing bench, eight-block	34
Rope-making machines, wire	89	Woven wire	90
Ryland's wire factory	82		
SAFETY pins	150		

