

**BIRLA CENTRAL LIBRARY**

**PILANI (RAJASTHAN)**

Call No. **662. B**

**H662F**

Accession No. **33751**

Acc. No. ....

**ISSUE LABEL**

**Not later than the latest date listed below.**

--	--	--



# FUEL TESTING



# FUEL TESTING

## LABORATORY METHODS IN FUEL TECHNOLOGY

BY

**GODFREY W. HIMUS**

PH.D., A.R.C.S., D.I.C., M.I.CHEM.E.

SENIOR LECTURER IN FUEL TECHNOLOGY AT THE IMPERIAL COLLEGE OF SCIENCE  
AND TECHNOLOGY, LONDON; FORMERLY CHIEF CHEMIST TO THE  
MUNICIPAL ELECTRICITY DEPARTMENT, SHANGHAI

LONDON

LEONARD HILL LIMITED, 17 STRATFORD PLACE, W.

*First Edition* . . . . *March 1932*  
*Second Edition* . . . . *October 1942*



**THIS BOOK IS PRODUCED IN COMPLETE  
CONFORMITY WITH THE AUTHORIZED  
ECONOMY STANDARDS**

**PRINTED IN GREAT BRITAIN AT  
THE UNIVERSITY PRESS  
ABERDEEN**

## *PREFACE TO THE FIRST EDITION*

As the result of several years' experience in the application of the principles of fuel technology to large boiler plant, and in the practical teaching of those principles in the Department of Chemical Technology at the Imperial College of Science and Technology, the author accumulated numerous notes and typed instructions which, revised and expanded, form the basis of the present work.

The importance of fuel to industry at the present day is common knowledge, and the necessity of reducing costs by the choice of fuel most suited to the needs of the case and by checking deliveries is indisputable. This necessitates careful sampling and examination. Practically every works is a purchaser and user of fuel in some shape or form in greater or lesser quantity, and it is safe to say that in the vast majority of cases, costs of production could be appreciably reduced by greater attention to the purchase and utilisation of that fuel.

In order that comparable results may be obtained, and to avoid disputes between buyer and seller, it is necessary that the methods of sampling and examination should be standardised; therefore the methods given are as far as possible those specified by competent authorities, such as the British Engineering Standards Association and the Fuel Research Board.

Considerations of cost have precluded any attempt at the production of an exhaustive treatise; moreover, the author has endeavoured as far as possible to describe those methods of which he has had practical experience, and this to some extent explains omissions which may be noticed.

A certain limited amount of theoretical matter, particularly concerning the present state of our knowledge of



## **Fuel Testing**

the origin, formation and constitution of coal, has been introduced. This has been considered necessary to a proper appreciation of the problems involved in the testing of coal and the interpretation of the results. No attempt at a detailed exposition is made, and for further information the reader is referred to one or other of the standard works on coal and fuel technology generally.

The author desires to offer grateful acknowledgments of assistance to the following: To H. B. Cronshaw, B.A., Ph.D., A.R.S.M., A.I.C., and to S. G. Ward, Ph.D., A.R.C.S., for reading the typescript and proofs; to W. C. Hancock, B.A., F.I.C., for supplying the section on the analysis of coal ash; to D. M. Newitt, D.Sc., A.R.C.S., for permission to reproduce instructions for the use of the Bone and Newitt gas analysis apparatus; to W. S. Smith, for preparing the photographs of cokes for plates I and II; to the Institution of Petroleum Technologists, H.M. Stationery Office, and the British Engineering Standards Association for permission to make use of their publications; and to the following for the loan of blocks: H. Nielsen, Messrs. A. Gallenkamp, Griffin and Tatlock, the Foster Instrument Co., the Cambridge Instrument Co., G. Cussons, Charles Cook and Sons, Duguids Ltd., and Lewents and Wilkinson.

LONDON, *March*, 1932.

## *PREFACE TO THE SECOND EDITION*

DURING the decade which has elapsed since the first edition of this book was published, additional work has been carried out on methods of sampling and analysis of both solid and liquid fuels, and the results have been embodied in revised specifications and publications by the British Standards Institute, the Fuel Research Board and the Institute of Petroleum. Finality, however, has not been, nor can it ever be, reached. New and improved methods of sampling and analysis are continually being sought and devised and are from time to time described in technical literature. The whole subject is therefore in a continued state of flux, and the Fuel Technologist must therefore be on the look-out for reports of new and improved methods, some of which, sooner or later, by a process of natural selection will survive and find their way into standard specifications. Where, however, buying and selling of fuel are in question, and particularly where litigation may arise over questions of non-fulfilment of contracts, the current British Standard Specifications must generally form the last court of appeal where methods are concerned. The descriptions, therefore, of methods of sampling and analysis given in this book are therefore drawn up so as to be consistent with the latest specifications.

But while specifications are necessary, they inevitably tend to be drawn up somewhat on the lines of cookery-book recipes, and with a minimum of discussion of general principles. In what follows the Author has endeavoured to avoid presenting the descriptions in specification form. He has tried, rather, to discuss general principles, while adhering to the spirit of the specifications.

The conditions brought about by the present war have

## Fuel Testing

Increased the need for economy of fuel, while at the same time restricting the availability of certain grades, so that although the principles underlying the selection of coal for various purposes remain unchanged, consumers are unable to make as free a choice as heretofore. In this connection it has been pointed out to the Author by Dr. E. S. Grumell that from the *national* point of view, the use of low-ash coal is rather to be deprecated than encouraged, at any rate for purposes such as raising steam; low-ash coals are produced and sold on a competitive basis, and very often there is considerable loss of combustible matter in so doing, loss which is avoided when less clean coal is demanded.

It is a remarkable and somewhat disturbing fact that sampling and examination of fuel is frequently regarded rather as a luxury (and expensive at that) than as a necessity, and the Author has on several occasions been asked, "What is the object of analysing fuel?" and "What are we going to gain by going through all this rigmarole you have suggested?" The position seems to be that for some reason fuel is not regarded as a raw material, in so far as it does not normally enter directly into the product, but is employed merely incidentally as a means of producing heat or power. Extra point is also given to these (seemingly) awkward questions by the restricted choice of fuels available, often resulting in the necessity of the consumer accepting what grade happens to be capable of being delivered when delivery can be effected. The answer is that just as variation in quality of direct raw material requires alteration in the methods of running the plant, so changes in the quality of fuel demand adaptations in the methods of using it, and unless the nature of the change in the quality of the fuel or other material is known before the material goes into process, intelligent alteration in the process cannot be made.

The Author has also been asked, "How is the small concern to bear the cost of the apparatus and skilled labour required to take samples of fuel and to analyse them when taken?" This seems to be a question of the possibility of organising co-operative laboratories, supported by a number

## Preface to the Second Edition

of small firms paying proportionally to the use they make of the laboratories.

The fact is that our methods of buying and selling coal are antedeluvian; coal is bought and sold on a basis of weight and not of heat. The small consumer is at the mercy of the coal merchant, and has no guarantee of the quality of the coal or coke he is purchasing; all he is entitled to is a definite weight of something called "coal" or "coke," but how much of the material is combustible is quite another matter. Carbonised fuels (coke and semi-coke) are particularly bad from this point of view; the Author has found as much as 17 per cent. of moisture in semi-coke without being entitled to any legal compensation for what can only be described as gross adulteration. For this state of affairs there is no justification; solid fuel could and should be sold on a thermal basis, at a "declared" calorific value in the same way as gas or electricity. Granted the problem is less simple than that presented by coal-gas—there are vested interests in the way of all progress—but until it is solved, and this will require education of the users of fuel to insist on the necessary reforms, utilisation of our resources of fuel cannot be really efficient.

In preparing the second edition of this book, the same general plan as adopted in the original edition has been followed. At the same time, however, there have been certain modifications, the most important of which are (a) the omission of the introduction and the chapter on the classification of coal, and (b) the addition of a chapter on combustion calculations. Descriptions of analytical methods have been brought up to date and are consistent with those recommended by the British Standards Institution, the Fuel Research Board and the Institute of Petroleum. The additions which have been made have necessitated some increase in the size of the book, notwithstanding the space saved by the deletions referred to.

The Author desires to express his thanks to the British Standards Institution, H.M. Stationery Office and the Institute of Petroleum for permission to make use of their

## **Fuel Testing**

publications and illustrations and for the loan of blocks ; to H. Etherington for permission to reproduce Table XXIV, the Editor of " Fuel in Science and Practice " for permission to reproduce figures of the Suction Drill for sampling coal and of the Jones-Miller gas calorimeter, and to the following firms for the loan of blocks or for permission to reproduce illustrations : Messrs. A. Gallenkamp, Griffin and Tatlock, the Foster Instrument Co., the Cambridge Instrument Co., Duguids Ltd., Benn Bros., and the " Colliery Guardian."

The Author would like to take this opportunity of again expressing his thanks to his colleagues Mr. W. C. Hancock, B.A., F.I.C., and Professor D. M. Newitt, D.Sc., A.R.C.S., for their valuable contributions on the analysis of coal ash and the use of the Bone and Newitt gas analysis apparatus respectively.

IMPERIAL COLLEGE OF SCIENCE AND TECHNOLOGY,  
*21st August, 1942.*

# CONTENTS

## CHAPTER I

### *SAMPLING COAL FOR ANALYSIS*

	PAGES
GENERAL PRINCIPLES. METHODS OF SAMPLING COAL AND COKE. SUCTION-DRILL SAMPLING OF COAL. SAMPLING COKE FOR ANALYSIS . . . . .	1-27

## CHAPTER II

### *THE PROXIMATE ANALYSIS OF COAL*

DETERMINATION OF MOISTURE. VOLATILE MATTER, ASH. REPORT- ING THE PROXIMATE ANALYSIS. INTERPRETATION OF THE PROXIMATE ANALYSIS. THE CAKING POWER OF COAL. THE SWELLING PROPENSITY OF COAL. PROXIMATE ANALYSIS OF COKE . . . . .	28-47
--	-------

## CHAPTER III

### *THE ULTIMATE ANALYSIS OF COAL*

DETERMINATION OF CARBON AND HYDROGEN. DETERMINATION OF NITROGEN, SULPHUR, THE DISTRIBUTION OF SULPHUR. DETER- MINATION OF OXYGEN. THE ANALYSIS OF OIL SHAKS AND MATERIALS HIGH IN MINERAL MATTER. ULTIMATE ANALYSIS OF COKE . . . . .	48-60
---	-------

## CHAPTER IV

### *MISCELLANEOUS DETERMINATIONS*

"FIXED" AND "VOLATILE" SULPHUR. ARSENIC CARBON DIOXIDE. CHLORINE. SOLUBLE MINERAL SALTS . . . . .	61-72
--	-------

## CHAPTER V

### *THE CALORIFIC VALUE OF SOLID AND LIQUID FUELS*

DIRECT METHODS. INDIRECT METHODS. THE HIGH PRESSURE BOMB CALORIMETER. GROSS AND NETT CALORIFIC VALUES . . . . .	73-91
--	-------

## APPENDIX TO CHAPTERS I TO V

REPRODUCIBILITY OF ANALYTICAL RESULTS . . . . .	90-91
---	-------

# Fuel Testing

## CHAPTER VI

### *CARBONISATION ASSAYS OF COAL*

	PAGES
LOW TEMPERATURE ASSAY. APPARATUS AND METHOD. NOTES ON MANIPULATION. ASSAY OF STRONGLY SWELLING COALS. PRESENTATION OF RESULTS. GAS CALCULATIONS. CORRELATION WITH LARGE-SCALE PRACTICE. HIGH TEMPERATURE ASSAY. APPARATUS AND METHOD. CORRELATION WITH LARGE-SCALE PRACTICE . . . . .	92-113

## CHAPTER VII

### *THE MINERAL MATTER IN COAL*

GENERAL DISCUSSION. WASHABILITY TESTS. APPLICATION TO PRACTICE . . . . .	114-125
--	---------

## CHAPTER VIII

### *THE ANALYSIS OF COAL ASH*

126-135

## CHAPTER IX

### *THE FUSION POINT OF COAL ASH*

GENERAL DISCUSSION. THE FORMATION OF CLINKER. DETERMINATION OF FUSION POINT . . . . .	136-143
---	---------

## CHAPTER X

### *GAS ANALYSIS*

SAMPLING. GENERAL METHODS OF ANALYSIS. EXPLOSION AND COMBUSTION METHODS. PREFERENTIAL COMBUSTION OF HYDROGEN. APPARATUS USED. THE IMPROVED HEMPEL APPARATUS. THE HAYS APPARATUS. THE BONE AND NEWITT GAS ANALYSIS APPARATUS. TREATMENT OF GAS RESIDUES. MISCELLANEOUS DETERMINATIONS . . . . .	144-179
--	---------

## CHAPTER XI

### *THE CALORIFIC VALUES OF GASES*

CALCULATION OF CALORIFIC VALUE. DIRECT MEASUREMENT OF CALORIFIC VALUE. APPARATUS USED IN GAS CALORIMETRY. THE BOYS NON-RECORDING GAS CALORIMETER. THE JONES-MILLER SMALL-SCALE GAS CALORIMETER. THE PARTIAL DRYING OF GAS . . . . .	180-201
---	---------

CHAPTER XII

*TESTS ON LIQUID FUELS*

	PAGES
SAMPLING. SPECIFIC GRAVITY. VISCOSITY. FLASH-POINT. SEDIMENT INSOLUBLE IN BENZENE. WATER. CARBON RESIDUE. ASPHALTENES. POUR-POINT. ASH. CALORIFIC VALUE AND SULPHUR . . . . .	202-226

CHAPTER XIII

*TECHNICAL PYROMETRY*

GENERAL. MERCURY-IN-GLASS THERMOMETERS. DISTANCE THERMOMETERS. THERMO-ELECTRIC PYROMETERS. RESISTANCE PYROMETERS. OPTICAL PYROMETERS. TOTAL RADIATION PYROMETERS. FUSION PYROMETERS. THE SIEMENS PYROMETER. TEMPERATURE OF GASES IN PIPES AND FLUES . . . . .	227-241
---	---------

CHAPTER XIV

*THE SELECTION OF COAL FOR INDUSTRIAL USES*

STEAM RAISING. GAS-PRODUCER OPERATION. PRODUCTION OF METALLURGICAL COKE. MANUFACTURE OF TOWN'S GAS. LOW TEMPERATURE CARBONISATION. PULVERISED FUEL FIRING. DOMESTIC PURPOSES. THE PURCHASE OF COAL UNDER CONTRACT. THE PREPARATION OF TECHNICAL REPORTS . . . . .	242-248
---	---------

CHAPTER XV

*COMBUSTION CALCULATIONS*

AIR REQUIRED FOR COMBUSTION. INCOMPLETE COMBUSTION. AIR REQUIRED FOR COMBUSTION OF GASEOUS FUELS. LOSS OF HEAT IN PRODUCTS OF COMBUSTION. EFFECT OF MOISTURE IN GAS AND AIR. GAS-PRODUCER CALCULATIONS. DISSOCIATION	259-282
--	---------

INDEX . . . . .	283-288
-----------------	---------





## LIST OF ILLUSTRATIONS

	PAGE
Fig. 1. APPARATUS FOR DETERMINATION OF MOISTURE ON THE 2-LB. SAMPLE . . . . .	12
„ 2. APPARATUS FOR DETERMINATION OF MOISTURE . . . . .	14
„ 3. SAMPLE DIVIDER. RIFLE TYPE . . . . .	18
„ 4. SUCTION-DRILL SAMPLER FOR COAL . . . . .	20
„ 5. BONE AND SILVER APPARATUS . . . . .	31
Plates I and II. RESIDUES FROM BONE AND SILVER APPARATUS <i>opp.</i>	32-33
Fig. 6. APPARATUS FOR DETERMINING THE SWELLING PROPENSITY OF COAL . . . . .	43
„ 7. SILHOUETTES OF COKE BUTTONS IN SWELLING TEST . . . . .	44
„ 8. APPARATUS FOR DETERMINATION OF VOLATILES ON COKE . . . . .	46
„ 9. ELECTRIC COMBUSTION FURNACE FOR CARBON AND HYDROGEN . . . . .	49
„ 10. APPARATUS FOR DETERMINATION OF ARSENIC . . . . .	63
„ 11. APPARATUS FOR DETERMINATION OF CARBON DIOXIDE IN COAL . . . . .	66
„ 12. GRIFFIN-SUTTON BOMB . . . . .	82
„ 13. LOW TEMPERATURE CARBONISATION APPARATUS . . . . .	95
„ 14. SCALE DRAWINGS OF PARTS OF DISTILLATION APPARATUS . . . . .	96
„ 15. DETAILS OF PACKING THE DISTILLATION TUBE. HIGH TEMPERATURE ASSAY . . . . .	106
Plate III. ASSAY COKES FROM THREE TYPES OF BITUMINOUS COAL <i>opp.</i>	110
Fig. 16. THE HENRY TUBE FOR WASHABILITY TESTS . . . . .	118
„ 17. ASH CHARACTERISTIC CURVES OF A COAL WHICH WOULD BE EASY TO CLEAN . . . . .	121
„ 18. FLOAT-AND-SINK TEST ON A COAL WHICH WOULD BE DIFFICULT TO CLEAN . . . . .	124
„ 19. MOULD FOR PREPARATION OF ASH CONES, AND EXAMPLES OF FRESH AND FUSED CONES . . . . .	139
„ 20. GAS HEATED VERTICAL MUFFLE FURNACE FOR TESTING COAL ASH . . . . .	142
„ 21. DIAGRAM ILLUSTRATING THE FORMATION OF POCKETS OF "DEAD" GAS . . . . .	146
„ 22. BULBS FOR SAMPLING GASES . . . . .	147
„ 23. APPARATUS FOR COMBUSTION OF HYDROGEN OVER HEATED PALLADIUM . . . . .	154
„ 24. APPARATUS FOR COMBUSTION OF HYDROGEN OVER COPPER OXIDE . . . . .	156

## Fuel Testing

	PAGE
Fig. 25. HEMPEL'S IMPROVED GAS BURETTE . . . . .	159
„ 26. HEMPEL'S ABSORPTION PIPETTES . . . . .	160
„ 27. HEMPEL EXPLOSION PIPETTE . . . . .	161
„ 28. HAYS PORTABLE GAS ANALYSER. FOR CO <sub>2</sub> ONLY . . . . .	162
„ 29. HAYS PORTABLE GAS ANALYSER. THREE-GAS TYPE . . . . .	163
„ 30. THE BONE AND NEWITT GAS ANALYSIS APPARATUS . . . . .	165
„ 31. APPARATUS FOR FRACTIONATION OF GASES BY LIQUID AIR . . . . .	174
„ 32. THE BALANCED GAS GOVERNOR . . . . .	186
„ 33. THE BOYS GAS CALORIMETER . . . . .	188
„ 34. ARRANGEMENT OF APPARATUS FOR THE BOYS TEST . . . . .	189
„ 35. THE JONES-MILLER GAS CALORIMETER . . . . .	194
„ 36. BURNER OF THE JONES-MILLER GAS CALORIMETER . . . . .	195
„ 37. THE JONES-MILLER GAS CALORIMETER. THE CALORIMETER. . . . .	196
„ 38. THE EATON WET AND DRY BULB HYGROMETER . . . . .	200
„ 39. THE REDWOOD NO. 1 VISCOMETER . . . . .	207
„ 40. 50-ML. FLASK FOR REDWOOD VISCOMETER . . . . .	208
„ 41. U-TUBE VISCOMETER . . . . .	210
„ 42. ABEL FLASH-POINT APPARATUS. . . . .	212
„ 43. COVER, ABEL FLASH-POINT APPARATUS . . . . .	213
„ 44. THE PENSKEY-MARTENS CLOSED TESTER . . . . .	216
„ 45. DEAN AND STARK APPARATUS . . . . .	219
„ 46. RECEIVER FOR DEAN AND STARK APPARATUS . . . . .	219
„ 47. CARBON RESIDUE APPARATUS . . . . .	221
„ 48. POUR-TEST APPARATUS . . . . .	224
„ 49. CALIBRATION OF THERMO-COUPLES . . . . .	232
„ 50. FOSTER DISAPPEARING FILAMENT PYROMETER . . . . .	235
„ 51. THE DISAPPEARING FILAMENT . . . . .	<i>opp.</i> 235
„ 52. THE FÉRY RADIATION PYROMETER . . . . .	<i>opp.</i> 235
„ 53. OPTICAL ARRANGEMENT OF THE FÉRY PYROMETER . . . . .	236
„ 54. FOCUSING THE FÉRY PYROMETER . . . . .	236
„ 55. THE FOSTER FIXED-FOCUS RADIATION PYROMETER . . . . .	237
„ 56. SÉGER CONES . . . . .	239
„ 57. THE RELATION BETWEEN CARBON DIOXIDE, OXYGEN AND EXCESS AIR IN THE COMBUSTION OF COAL . . . . .	261
„ 58. THE RELATION BETWEEN THE CARBON DIOXIDE AND OXYGEN IN THE DRY GASES FROM THE COMBUSTION OF A COAL . . . . .	262
„ 59. PROPERTIES OF SATURATED STEAM AT LOW PRESSURES . . . . .	271

## CHAPTER I

# SAMPLING COAL FOR ANALYSIS

### GENERAL PRINCIPLES

THE final sample on which the report on a consignment of coal amounting to a thousand tons or more is to be written consists generally of less than a hundred grams ; hence unless the sample is truly representative of the main bulk, the results of the analysis, however accurately and carefully carried out, are valueless and misleading. A sample, if it is to be representative, must give a true picture of the whole bulk of the coal ; it must contain the correct proportions of large and small coal and of the large and small pieces of foreign matter and impurities.

Having regard to the importance of correct sampling and of its relation to the value of the analysis of the fuel, wherever possible, there should be a special sampling staff, under the direct supervision of the laboratory, responsible for the proper sampling of all materials received at and despatched from the works. The practice of allowing the important operation of sampling to be carried out by any casual labourer who happens to be available, with but cursory supervision, should never be permitted.

The difficulty in obtaining a representative sample lies in the fact that coal is heterogeneous in a double sense ; firstly, impurities are always present, and, secondly, the distribution of the impurities is not uniform, the ash from any coal being generally higher in the smaller sizes.

The stages involved consist (a) in taking a representative gross sample which must include a due proportion of the various sizes of the coal and of the impurities, (b) rough grinding this gross sample to about  $\frac{1}{4}$  in. and its reduction to a quantity of about 10 lb. for delivery to the laboratory, and (c) further reduction to about  $\frac{1}{4}$  lb. and fine grinding to 60 mesh I.M.M. or 72 mesh B.S. sieve, from which finely ground sample the quantity required for analysis may be withdrawn.

*Degree of Accuracy Required in Sampling.*—It is generally accepted that a limiting accuracy of  $\pm 1$  per cent. is sufficient, and that sampling should be carried out so that 99 times out of 100 the percentage of ash should be within 1 per cent. of the true ash. To obtain a greater accuracy than this involves a considerable increase in the weight of the gross sample ; to obtain an accuracy of 0.75

## Fuel Testing

per cent., it is necessary to take nearly twice the amount of coal which would give an accuracy of 1 per cent., and for an accuracy of 0.5 per cent. the quantity of gross sample must again be doubled. Further, it is probable that the increased accuracy would be offset by the errors incurred in reducing such large samples from the original weight to the small samples required for the laboratory.

It is necessary also to retain a sense of proportion between the errors in sampling and the errors in analysis ; so long as the errors of analysis are appreciable there is no object in aiming at exaggerated accuracy in sampling.

In the determination of ash the permissible differences between duplicate determinations are, according to the American Chemical Society : <sup>1</sup>

	Same Analyst.	Different Analysts.
No carbonates present . . . . .	0.2	0.3
Carbonates present . . . . .	0.3	0.5
Coal with more than 12 per cent. ash, containing carbonates and pyrite . . . . .	0.5	1.0

The Sampling Committee of the British Standards Institution agree that such errors are probable, and they therefore conclude that a maximum error of  $\pm 1$  per cent. is reasonable in sampling.

*The Heterogeneity of Coal.*—If 100 wagons filled with coal from the same seam of the same mine be sampled, the ash will vary from wagon to wagon about a mean value which is called the “ true ash.” If the sum of the deviations from the true ash (regardless of sign) be divided by the total number of samples, the quotient will give the average deviation from the mean ; this is the “ average error ” of the coal in the 100 wagons, and is a measure of the heterogeneity of the coal.

The *probable error* is such that half the results have a less error than this and half have a greater error. With sufficient accuracy, the probable error  $r = 0.85$  average error. If a fuel has an average error of 1 per cent. and a probable error of 0.85 per cent., then, out of 100 samples tested, 50 will have an error less than 0.85 and half greater than 0.85 per cent. It has been shown experimentally by E. S. Grumell and A. C. Dunningham <sup>2</sup> that the theory of errors

applies to the sampling of coal, therefore  $R = \frac{r}{\sqrt{n}}$ , where  $r$  = the probable error of the fuel = 0.85 of the average error,  $n$  = the number of samples, trucks, etc., considered, and  $R$  = probable error of the final ash determined. It is therefore possible to determine how many trucks must be sampled or how many increments must

## Sampling

be taken to make up the gross sample of any coal so that this may be representative of the whole bulk. It has been shown mathematically that if in 99 cases out of 100 the ash as determined is to be within  $\pm 1$  per cent. of the true ash,  $R$  must be 0.26, therefore, knowing the average error of the coal, it is possible to calculate how many increments must be taken in making up the gross sample.

Grumell and Dunningham found that the average error for British coals below 3 in. was related by a linear law to the ash of the coal: Average error =  $0.143 \times \text{Ash} + 0.21$ . L. A. Bushell,<sup>3</sup> however, found that for South African coals, the average error was not a function of the percentage of ash, which he explains by suggesting that Grumell and Dunningham failed to distinguish between the ash which is intimately associated with the coal substance (intrinsic ash) and the ash which arises from impurities in the coal (extrinsic ash).

That this explanation is reasonable is shown by the results of washing tests carried out (under the direction of the Author) some years ago on Transvaal coals; eight coals were examined, and it was found that little reduction in the ash resulted from washing in a hand-operated jig. By far the greater part of the ash was therefore intrinsic. In British coals, on the other hand, most of the mineral matter is easily removable "dirt" mechanically mixed with the clean coal and therefore more likely to be distributed erratically through the mass of the coal.

### *General Conclusions from the Work of the Sampling Committee of the British Standards Institution*

(i) The number of increments or the number of wagons to be sampled is independent of the total weight of coal to be sampled, *provided that the increments are uniformly distributed.*

(ii) The number of increments to be taken or the number of wagons to be sampled depends only on the average error of the fuel.

(iii) The weight of each increment must depend on the size of the fuel.

(iv) It is preferable to make up the gross sample by taking a large number of small increments than a smaller number of larger increments.

## METHODS OF SAMPLING COAL AND COKE

The procedure described is based on and is consistent with British Standard Specification No. 1017 (1942) which replaces previous specifications; it does not, however, supersede B.S.S. No. 735 (1937), which was drawn up with special reference to the conduct of boiler trials.

The weight of the gross sample is based on (a) the size of the coal, (b) its variability, and (c) the accuracy required. The minimum

TABLE I  
MINIMUM WEIGHTS FOR SMALL COAL

Group.	Percentage of Ash.	0 to 6.			6 to 10.			10 to 15.			15 to 20.										
		3	2	1½	3	2	1½	3	2	1½	3	2	1½								
Accuracy: 99 cases in 100.	Maximum size of fuel (in.) . . . . .	1	1	1	1	1	1	1	1	1	1	1	1								
	Minimum weight of increment (lb.) . . . . .	2	3	4	2	3	4	2	3	4	2	3	4								
	Minimum no. of increments . . . . .	167	376	667	1043																
± 0.25	Minimum weight of gross sample (lb.) . . . . .	1002	668	501	334	167	2256	1504	1128	752	376	4002	2668	2001	1334	667	6256	4172	3129	2086	1043
	Minimum no. of increments . . . . .	42	94	167	261																
	Minimum weight of gross sample (lb.) . . . . .	252	168	126	84	42	564	376	282	188	94	1002	668	501	334	167	1566	1044	783	522	261
± 0.5	Minimum no. of increments . . . . .	19	42	74	116																
	Minimum weight of gross sample (lb.) . . . . .	114	76	57	38	19	252	168	126	84	42	444	296	222	148	74	696	464	348	232	116
	Minimum no. of increments . . . . .	11	24	42	65																
± 0.75	Minimum weight of gross sample (lb.) . . . . .	66	44	33	22	11	144	96	72	48	24	252	168	126	84	42	390	260	195	130	65
	Minimum no. of increments . . . . .																				
	Minimum weight of gross sample (lb.) . . . . .																				

The degree of accuracy takes account of

- (a) The error involved in the collection of the gross sample.
- (b) The aggregate error involved in reducing the gross sample to a weight suitable for examination in the laboratory, and
- (c) The error of analysis.

## Sampling

weight of each increment depends on the size of the coal, while the number of increments required for a given accuracy is a function of the average error (p. 2), which generally increases with the total ash, but more particularly with the "free" ash, i.e. the ash of the "dirt" associated with the coal and which sinks in a liquid of S.G. 1.6.

It is assumed in the specification that the ash is made up of 4 per cent. "fixed" ash (i.e. the ash on the coal which floats at a S.G. of 1.6), and "free" ash which arises from associated materials such as shale and pyrite. The variability of coal is determined primarily by the free ash, a fact that must be borne in mind when applying Table I to coals from different countries. For example, a coal with 15 per cent. total ash made up of 10 per cent. fixed and 5 per cent. free ash would be equivalent to, and be in the same group as a coal yielding 9 per cent. total ash, made up of 4 per cent. fixed and 5 per cent. free ash.

**TABLE II**  
**MINIMUM WEIGHTS FOR LARGE COAL**

*Minimum Weight of each Increment 10 lb. Accuracy  $\pm 1.0$*

Ash Per Cent.	Minimum Weight of Gross Sample (lb.).				Minimum no. of Increments.			
	Large Coal, Screened Over:			Unscreened Run-of-mine.	Large Coal, Screened Over:			Unscreened Run-of-mine.
	3 in.	1½ in.	¾ in.		3 in.	1½ in.	¾ in.	
Up to 4	100	100	100	—	10	10	10	—
4 to 5	150	180	180	220	15	18	18	22
5 to 6	240	300	300	360	24	30	30	36
6 to 7	330	410	410	500	33	41	41	50
7 to 8	430	530	530	640	43	53	53	64
Over 8	500	630	630	750	50	63	63	75

The degree of accuracy required in sampling (and therefore the weight of the gross sample) any given coal depends on the purpose for which the sample is taken, whether for commercial purposes, for routine testing on a factory or power station, or in connection with special performance and efficiency trials. Generally, it is sufficient if 99 samples out of 100, taken from a consignment, give results within 1 unit of the true ash; if this is so, a large number of the samples would give results much closer than  $\pm 1$  unit, thus:

50	of the samples would be between	$\pm 0.26$	unit.
82	" " " " " "	$\pm 0.5$	"
88	" " " " " "	$\pm 0.6$	"
93	" " " " " "	$\pm 0.7$	"
96	" " " " " "	$\pm 0.8$	"
98	" " " " " "	$\pm 0.9$	"



## Fuel Testing

For special purposes a higher accuracy may be required, and Table I shows the weights of sample which must be taken whereby accuracies of 0.75, 0.5 and 0.25 of the true ash, with a probability of 99 in 100 may be obtained.

## Method of Collecting the Gross Sample

The coal as collected must be protected from rain, wind, sun and dust or any other foreign matter. Whenever possible, the sample should be taken while the coal is in motion.

The minimum weight of the gross sample must be that given in Tables I and II, except where the coal is sampled in wagons, when Tables III and IV are to be followed.

The required number of increments, regularly spaced over the whole consignment is taken by means of a scoop, capable of holding the weight of coal appropriate to the class and size of coal being sampled, each scooping being immediately transferred to a covered bin of convenient size, constructed of material and in such a condition that it will neither contaminate the sample nor absorb moisture from it: the bin should be in a cool place to avoid evaporation of moisture. To avoid frequent opening and closing, it is convenient to use a special cover, fitted with a small balanced trap-door opening inwards and provided with a hopper so that fuel placed in it will gravitate into the bin. A single filling-cover may be used for all the bins, being transferred from each full bin to the next empty one and replaced by the ordinary lid of the bin.

When sampling large, or mixed large and small coal, where the lumps exceed 10 lb. in weight, the increments must contain a section or sections cut evenly across the bedding planes of the large pieces, and including any inter-stratified or attached shale. The increments of the lumps and small coal may be placed in separate receptacles, and the final samples prepared by taking proportionate amounts of the lump and small on the basis of the assessment made by the sampler on the relative proportions in the delivery.

A. *During Discharge from Chutes.*—The required number of increments of the correct weight is taken at regular intervals (based on the rate of flow of the coal) by means of a ladle which is plunged into the flowing stream of coal from back and front alternately to ensure that a fair sample is taken. First runnings and side-trickles should be avoided. Where it is impracticable to collect increments from the full width and thickness of the stream of coal, increments must be collected systematically from all portions of the stream.

B. *From Conveyers.*—Attention must be paid to the distribution of the coal on the conveyer, since the larger coal tends to segregate to the edges of the conveyer. To avoid vitiating the sample, the requisite number of increments must be taken alternately from the sides and

middle of the conveyer, or by some other method which will ensure that bias due to segregation is eliminated. The scoop should sweep the bottom of the conveyer otherwise there will be a tendency to omit from the sample its correct proportion of fine coal. Wherever possible it is preferable to take the sample where the coal discharges from the conveyer.

When sampling from buckets and where the buckets hold large quantities of coal, if segregation has taken place during filling, increments must be drawn from the bottoms of the buckets as well as from the tops; alternatively, the increments should be taken as the buckets are being emptied.

Before sampling, the speed of the conveyer and the quantity of coal passing a certain point in a given time should be determined, so that proper spacing of the increments may be arranged over the whole consignment.

*C. From Feeding Devices: Barrows.*—The methods above can generally be applied to sampling from a table feeding coal into a pulveriser, producer or other appliance. Where, however, coal is to be sampled from barrows, special circumstances arise, since, during filling, an undue proportion of large pieces may tend to roll toward the ends of the barrow. Segregation should be prevented by distributing the fuel evenly: the scoop must be driven deeply into the barrow and lifted so that the fuel at the top slides off and leaves the scoop heaped to the maximum with fuel brought from beneath the surface.

*D. From Wagons.*—Where possible, the sample should be taken during loading or unloading. If this is not possible, the required number of increments must be distributed evenly over the whole number of wagons to be sampled.

(i) *During Discharge by Hand.*—The necessary number of increments is taken from the unloading shovel, the increments being distributed over the whole period of discharge. Samples taken in this way have been shown experimentally to agree very closely with samples taken from the same coal on a conveyer after unloading.

(ii) *Small Coal in Loaded Wagons.*—Holes at least 12 in. deep and as narrow as possible should be scooped at distances equal to about one-sixth of the diagonal line from the corners of the wagon and also from the centres of the wagons. The position of the holes must be varied regularly from wagon to wagon.

Each hole is to be scooped so as to leave, as far as possible, a vertical wall on the side nearest the centre of the wagon, and the increment is taken by scraping the sampling shovel from the bottom to the top of the steepest side of the hole. Alternatively, the increment may be drawn from below the surface of the bottom of the hole.

## Fuel Testing

The samples taken from the tops of wagons cannot be considered as representative of the moisture content in washed or wetted coal ; when a sample cannot be taken from the whole of the wagon during discharge, the sample for moisture must be taken from the bottom of a hole dug in the centre of the wagon as nearly as possible half-way through the depth of the coal.

With many types of small coal, the sample taken from the tops of wagons may not be representative owing to segregation.

(iii) *Large Coal, or a Mixture of Large and Small Coal in Loaded Wagons.*—This includes screened large coal or screened large coal containing not more than 20 per cent. of small coal, less than 3 in. square mesh.

Increments are to be taken by removing large lumps and making holes about 18 in. deep into the surface coal in the wagon, and taking from a representative lump from the bottom of each hole, a section, or a representative portion of a section, cut as evenly as possible across the bedding planes and including interstratified or attached shale.

The position of the holes must be varied regularly from wagon to wagon. The weight and number of increments of large coal must be in accordance with Table III.

TABLE III

### WAGON SAMPLING

*Weight and Number of Increments of Large Coal. Accuracy  $\pm 1.0$*

Ash Per Cent.	Minimum Weight of Each Increment (lb.)	Minimum Weight of Gross Sample (lb.)	Minimum Number of Increments.
Up to 4	2	100	50
4 to 5		145	73
5 to 6		240	120
6 to 7		330	165
7 to 8		425	213
Over 8		500	250

Representative increments of small coal (Table IV) must also be taken from the whole. The increments of lump and small coal may be placed in separate receptacles and the final sample made up by taking proportionate amounts of the lump and the small on the basis of an assessment made by the sampler on the relative proportions in the delivery. This may be done before, or at some stage in the reduction of the two samples ; if during reduction, separate moisture samples must be taken from the samples of lump and small.

If a single receptacle is employed, the weights of sample from the large and small coal must be in the same relative proportions as the large and small coal in the delivery.

## Sampling

(iv) *Run-of-Mine Coal or Large Coal containing more than 20 Per Cent. Small Coal.*—The weight and number of increments of “large” must be in accordance with Table III, and for the “small,” the minimum weights of gross sample as in Table IV, but each increment should be 2 lb. instead of 1 lb.

TABLE IV  
WAGON SAMPLING

*Minimum Weight of Gross Samples of Small Coal. Accuracy  $\pm 1.0$ .  
Minimum Weight of each Increment 1 lb.*

Ash Per Cent.	Minimum Weight of Gross Sample (lb.)		
	Coal up to 1 in.	Coal up to 2 in.	Coal up to 3 in.
6	20	40	50
7	25	53	65
8	33	65	80
9	40	78	98
10	45	90	113
11	53	105	133
12	60	120	150
13	68	135	170
14	75	150	190
15	85	170	213
16	95	185	235
17	103	205	255
18	110	220	280
19	120	240	300
20	130	260	325
21	140	280	350
22	150	300	375
23	160	320	405
24	173	345	433
25	185	370	463

E. *From Heaps or Piles.*—Although segregation may be more serious than in wagons, an accurate sample can be taken from small heaps not exceeding 3 ft. in height by taking the requisite number of increments evenly distributed throughout the heap. If the height exceed 3 ft., it may be difficult to obtain increments from the lower layers. Samples taken only from the top or sides of a heap cannot be considered as representative of the whole heap, and this would be particularly true where the heap is made up of more than one coal.

### Treatment of the Gross Sample

Subsequent treatment of the sample should be carried out in a sample-house which is enclosed, roofed over, cool and free from

## Fuel Testing

draughts. As a preliminary, the number of samples to be prepared must be agreed on between the parties interested, and for performance and efficiency tests, at least one additional sample, over and above those required for analysis, must be prepared and retained in case a check is needed.

Since considerable loss of moisture may occur during mixing and crushing, and since it is generally necessary to know the original moisture on the coal, special samples, corresponding in number to the samples for analysis, must be collected. These are obtained from the gross samples which must therefore be correspondingly increased in weight. Where the moisture samples must be reduced in size it is preferable to use machinery which crushes rather than machinery which grinds.

Where the coal has been partially or totally air-dried, it is essential that it should not be exposed for any length of time to a current of air or to an atmosphere with an appreciably different temperature or humidity; should this condition not be observed, the content of moisture of the coal will alter to an extent which will depend on the variation in the atmospheric conditions.

## Methods of Collecting the Moisture Sample

Two methods are specified, (a) general process, which is applicable to all coals and which is especially suitable where crushing machinery is inadequate, and (b) a process which is applicable only to visibly dry coals.

(a) *General Method*.—When this method is employed, the weight of the gross sample must be increased by an amount equal to the weight of the moisture sample.

The gross sample is poured, without previous mixing, on to a plate to form a cone, which is then flattened out. From evenly-distributed points over the flattened heap, increments are taken as follows :

Coal up to 1 in.,	10 increments, each of 1 lb.
"    "    2    "	10    "    "    2    "
"    "    3    "	10    "    "    3    "

Large coal, increments obtained by taking sections across the bedding planes to give a total sample of 30 lb.

(b) *Alternative Method*.—This is to be applied only to visibly dry coal. The whole of the gross sample, without previous mixing, is mechanically crushed to  $\frac{1}{2}$  in., and from the crushed material, a moisture sample of 10 lb. is taken in 10 increments either while the coal is being discharged from the crusher or else after the crushed coal has been formed into a heap and flattened.

## Sampling

**Subsequent Procedure.**—A sample weighing as nearly as possible 2 lb. is withdrawn from the main moisture sample.

(i) If the coal does not exceed  $\frac{1}{2}$  in., the 2-lb. sample is withdrawn by taking not less than 10 increments.

(ii) If the coal is larger than  $\frac{1}{2}$  in., it is crushed mechanically, or by hand as rapidly as possible on a dry plate with minimum exposure to the atmosphere, and after crushing, the 2-lb. sample is withdrawn by taking not less than 10 increments. If, however, the coal is visibly wet, it must be air-dried before being crushed.

(iii) The 2-lb. sample is transferred to an airtight tin, which is clearly labelled "Moisture Sample."

*Air-Drying.*—The idea which was formerly prevalent that air-drying of coal must be carried out at or near room temperature for a period extending to as much as 120 hours, and even then at the risk of oxidation of the sample, has recently been shown to be unfounded. Equally accurate results may be obtained by partial air-drying if the coal is spread in a thin layer with free circulation of air for 6 to 10 hours at room temperature, or for  $1\frac{1}{2}$  to 3 hours at a temperature not exceeding  $50^{\circ}$  C.

The loss of moisture on air-drying is determined as follows: The moisture sample is collected in a dry, non-absorbent, non-corrodible tray which is weighed together with the coal. The coal is spread out to dry and the tray is dried and weighed. When air-drying is completed (at the end of from  $1\frac{1}{2}$  to 10 hours, depending on the conditions), the coal is returned to the tray and weighed therein. The loss of moisture is calculated as a percentage of the original weight of coal.

A tray 10 in. by 15 in. by 1 in. deep is suitable for drying 2 lb. coal spread in a layer approximately  $\frac{1}{2}$  in. deep. Suitable materials for constructing the trays are stainless steel and aluminium.

### Determination of the Moisture on the 2-lb. Sample

*Method 1.*—Applicable only to coals with less than 4 per cent. air-dried moisture (i.e. coals with calorific value of about 14,670 B.Th.Us. per lb. and carbon 82.5 per cent. and upwards on the dry ash-free basis).

The 2-lb. sample, spread out in a layer not exceeding  $\frac{1}{2}$  in. in thickness, is dried to constant weight in an oven heated to between  $100^{\circ}$  and  $110^{\circ}$  C. The approximate time required should be 5 to 6 hours, and the loss of weight should be checked at the 4th, 5th and 6th hour to determine whether a constant weight has been reached. The coal should be weighed hot to avoid absorption of moisture during cooling. Provision must be made to pass heated air through the oven to change the atmosphere 3 to 5 times an hour.

*Method 2.*—General method, applicable to all coals.

## Fuel Testing

The 2-lb. sample is heated with a petroleum distillate and the water vaporised with the oil is collected in a modified Dean and Stark apparatus (Fig. 1).

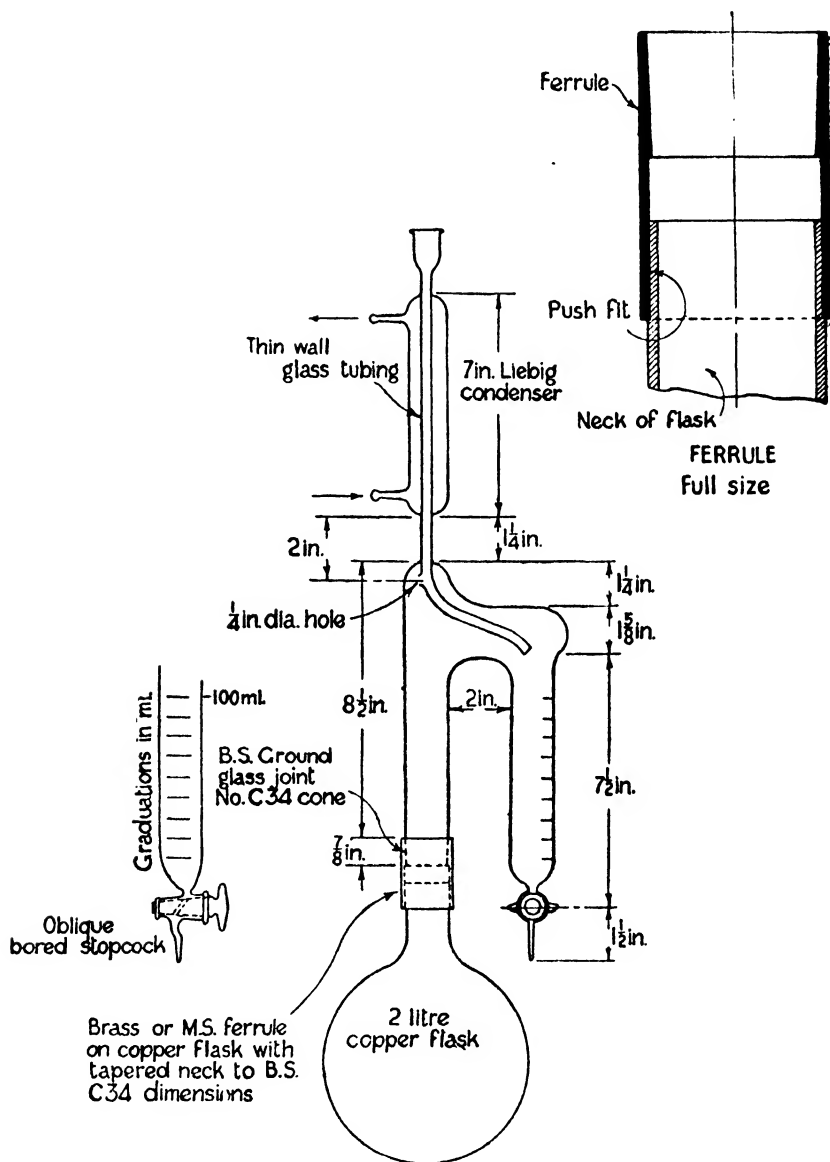

FIG. 1.—Apparatus for Determination of Moisture on the 2-lb. sample.

(Extracted, by permission, from British Standard No. 1017, 1942.)

The coal is contained in a short-necked copper flask of about 2 litres capacity, the mouth being fitted with a ferrule at its upper end to receive a B.S. C34 ground glass cone: the remainder of the

## Sampling

apparatus is constructed of borosilicate heat-resisting glass, with a receiver of about 100 ml. capacity, graduated in millilitres.

The 2-lb. sample is introduced into the tared flask, which is weighed again with the coal. All traces of coal-dust are cleaned from the socket and neck of the flask and connection is made to the glass part of the apparatus. 250 ml. of petroleum distillate of boiling range 150° to 180° C. are added through the top of the reflux condenser, the flask is supported over a small gas flame and the oil is distilled briskly. Distillation is continued until no further water collects in the graduated receiver, which requires about 6 to 8 hours, and the volume of water collected is noted. Should the quantity of water exceed the capacity of the receiver, a portion must be withdrawn and measured separately in a graduated cylinder. From the volume of water measured, the weight is calculated as a percentage on the original coal.

*Note.*—After completing the distillation, the glass-metal joint must be broken while the apparatus is still hot, or seizure will occur.

*Method 3.*—The sample is ground to pass a 6-mesh B.S. sieve. If the coal is visibly wet, or if it is of low rank, it must be air-dried prior to grinding, care being taken not to expose it to changes of temperature and humidity. If the samples are ground in a plate-mill, this must not be allowed to become heated by being used for successive samples. Alternatively, the sample may be screened through a 6-mesh B.S. sieve, the under-size being immediately returned to the tin, and the over-size rapidly crushed in a flat mortar with a flat pestle to pass the sieve, returned to the tin and mixed by shaking, the whole operation being carried out as rapidly as possible and with the minimum exposure to the atmosphere. With this procedure, air-drying is unnecessary except for performance and efficiency tests, when visibly wet coals must be air-dried.

The sample, having passed a 6-mesh B.S. sieve is reduced to 8 oz., and on this reduced sample the moisture is determined by one of the following methods :

(a) By drying 10 gm. in an oven at 105° to 110° C., (b) by drying 10 gm. in a porcelain boat in a current of dry nitrogen at  $108 \pm 2^\circ$  C., the boat being allowed to cool in a stream of dry nitrogen, or (c) by the "toluene" method.

*Toluene Method.*—This is particularly applicable to coals containing a high percentage of moisture, and which are liable to oxidation at 105° C., and may be used to determine the total moisture on coarsely crushed (14-mesh B.S. sieve) coals without air-drying.

A suitable quantity of the coal is collected from the sample (in small portions of from 2 to 5 gm.) which has been spread out in a thin layer on a metal plate. The coal, after being weighed, is



## Fuel Testing

transferred to the flask of the apparatus shown in Fig. 2, and 200 ml. of toluene are added. The toluene should be part of a stock which has previously been boiled, without coal, in the apparatus. The apparatus must be free from moisture, and the internal condenser must be chemically clean. The apparatus is assembled, the flask is immersed nearly to the neck in an oil-bath filled with heavy mineral oil, and the toluene is boiled briskly, heating being continued until

there is no change in the level of water in the receiver during 15 minutes. Any small quantity of moisture which adheres to the condenser may be washed down by a strong jet of toluene from a wash-bottle.

When the moisture has been transferred to the measuring tube, the apparatus is removed from the oil-bath, the measuring tube is removed and supported on a stand. Any droplets of moisture adhering to the upper portion of the tube may be washed down by a strong jet of toluene. When all the water has collected in the lower layer, the volume is read to the bottom of the meniscus.

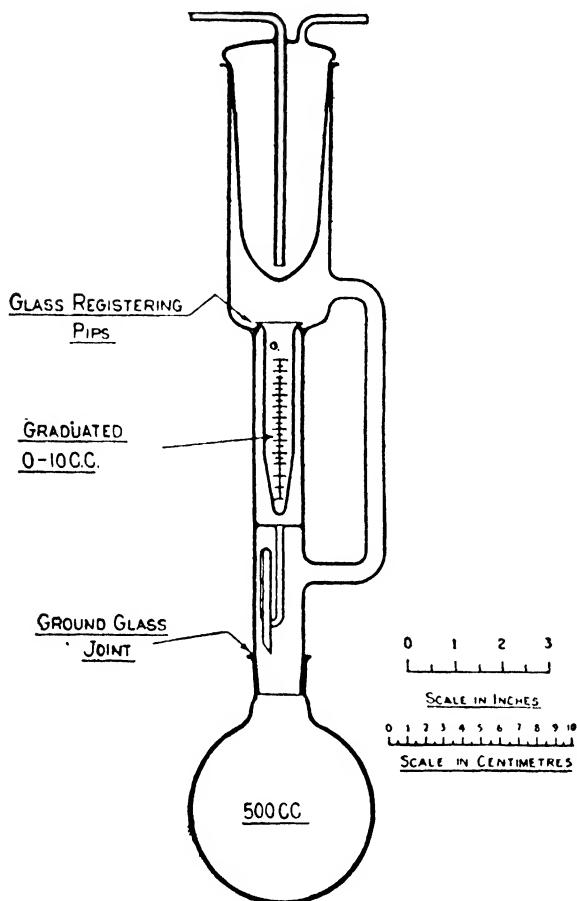

FIG. 2.—Apparatus for Determination of Moisture.  
(Extracted, by permission, from B.S. No. 420, 1931.)

It is essential that the tube should have been calibrated for a water-toluene meniscus.

The residue is removed from the flask, which, after being rinsed with toluene, is ready for a further determination. The condenser is emptied, immersed in a cleaning mixture (chromic acid in sulphuric acid is suitable), drained and rinsed with distilled water in a beaker. The surface is allowed to drain for 15 minutes, after which the

moisture is removed from the tip with absorbent paper. The condenser is then allowed to stand in air until the outer surface is dry. The apparatus is then ready to be assembled for the next determination.

### Preparation of the Sample for Analysis

The chances of incurring errors when preparing the gross sample for analysis are a function of the ash on the coal, and it is therefore necessary to modify the method of preparation of the laboratory sample in accordance with the ash content of the coal and the accuracy required. The methods recommended are based on the fact that the smaller the size to which the coal is crushed, and the larger the weight of the sub-sample, the smaller will be the errors of reduction.

Wherever possible, the gross sample should be reduced to  $\frac{1}{4}$ , or preferably  $\frac{3}{16}$  in. before its weight is reduced. It is also desirable that mechanical crushing and subdivision should be employed instead of the old method of coning and quartering, which involved laborious mixing and greater possibility of error. Sometimes it may be necessary to air-dry damp coals to avoid choking in the mill; where a separate sample for determination of moisture has been taken, no further determination is necessary.

Prolonged exposure of coal to the atmosphere is liable to lead to reduction of its calorific value and also to changes in its caking and swelling propensities; this effect becomes more pronounced with fine coal. Samples should therefore not be exposed for longer than is necessary to secure accurate manipulation. Hammer-mills, which enable samples to be rapidly reduced to small size in a single operation, are available, and of great utility.

Three methods of reduction are specified to be used respectively where in 99 cases out of 100 the deviation of the ash from the true percentage is to be (a)  $\pm 0.25$ , (b)  $\pm 0.75$ , and (c)  $\pm 1.0$  unit. The third method should be adopted where there are no facilities for crushing the whole of the sample to  $\frac{1}{4}$  in. or finer. It must be remembered that crushing and reduction of the sample in stages will probably introduce errors which will vary with the percentage of ash and the number of stages, also that the errors will be additive. It is important in manual crushing to have sufficient labour available provided with suitable stamps and hammers.

*Method (a).*—The remainder of the gross sample is crushed to pass a  $\frac{1}{4}$  or a  $\frac{3}{16}$  in. B.S. sieve and reduced by means of sample-dividers (*q.v.* p. 17) to the following amounts to ensure that the error in the reduction does not exceed 0.25 in 99 cases out of 100.

The selected sub-sample or sub-samples are then ground to pass a 14-mesh B.S. (10-mesh I.M.M.) sieve and reduced by sample-

## Fuel Testing

dividers of suitable dimensions to 2 lb. Provided the ash does not exceed 6 per cent. the sub-sample may be reduced to  $\frac{1}{2}$  lb.

TABLE V  
PREPARATION OF SAMPLE FOR ANALYSIS. METHOD (A)

Size of Coal after Crushing. In.	Ash Per Cent.	Weight to which Sample can be Reduced. Lb.	Maximum Error. (99/100.)
$\frac{1}{4}$	10	30	0.25
	6	10	0.22
	15	20	0.25
$\frac{3}{16}$	10	10	0.25
	6	3	0.24

This sample is ground to pass a 72-mesh B.S. (60-mesh I.M.M.) sieve and used for analysis. Analyses must be made in duplicate ; greater accuracy may be assured if, after crushing to  $\frac{1}{4}$  or  $\frac{3}{16}$  in. and halving the sample, each half is subdivided to provide a separate sample for analysis.

*Method (b).*—The sample is crushed to pass a  $\frac{1}{4}$  or a  $\frac{3}{16}$  in. B.S. sieve and reduced by a sample-divider of suitable dimensions to not less than the following amounts :

TABLE VI  
PREPARATION OF SAMPLE FOR ANALYSIS. METHOD (B)

Size of Coal after Crushing. In.	Ash Per Cent.	Weight to which Sample can be Reduced. Lb.	Maximum Error. (99/100.)
$\frac{1}{4}$	15	20	0.41
	10	10	0.39
	6	5	0.30
$\frac{3}{16}$	15	6	0.42
	10	3	0.42
	6	1 $\frac{1}{2}$	0.31

The selected sample is ground to pass a 7-mesh B.S. (5-mesh I.M.M.) sieve and reduced by sample-divider to 2 lb., or if the ash does not exceed 6 per cent., to 1 lb. The sub-sample is then ground to pass a 36-mesh B.S. (30-mesh I.M.M.) sieve for the determination of moisture and ash. If other analyses are required, the selected sample is reduced to not less than 2 oz. and ground to pass a 72-mesh B.S. (60-mesh I.M.M.) sieve.

*Note.*—If a suitable mill is available, the intermediate stages should be omitted and the sample ground direct to pass a 36-mesh B.S. sieve.

## Sampling

*Method (c).*—The remainder of the gross sample is crushed in stages and reduced by sample-divider at each stage to a quantity not less than that given in Table VII for the specified size and ash. To ensure that the maximum overall error of sampling is not exceeded, a maximum error of subdivision of 0.5 in 99 cases out of 100 is recommended.

TABLE VII  
PREPARATION OF SAMPLE FOR ANALYSIS. METHOD (C)

Ash Per Cent up to	6.				10.				15.			20.			Maximum Deviation from true Ash. 1/100.
Size of Coal in.	1½.	1.	¾.	½.	1½.	1.	¾.	½.	1.	¾.	½.	1.	¾.	½.	
Weight of sample after reduction. lb.	—	290	35	5	—	—	130	17	—	300	39	—	500	66	0.31
	410	180	21	3	—	630	77	10	—	170	22	—	290	34	0.38
	280	120	14	2	930	400	48	6	830	100	13	1500	180	23	0.46

The significance of the table is shown by the following example : If a gross sample of 800 lb. of 1-in. coal yielding 10 per cent. ash were halved, the percentage of ash on the two halves may differ from that of the original by  $\pm 0.46$  per cent. once in 100 tests. If each of the 400-lb. portions be crushed to pass a  $\frac{1}{2}$ -in. screen and reduced to about 50 in. by coning and quartering, the ash on the 50-lb. portions may again differ from that on the 400-lb. portion by  $\pm 0.46$  per cent. once in 100 tests.

The probability that the maximum errors of each operation would occur in one subdivision is small, but the result would lie between the extremes =  $10 \pm \sqrt{0.46^2 + 0.46^2} = 10.65$  and 9.35 per cent. in 99 tests out of 100.

If, on the other hand, the 800 lb. of 1-in. coal were crushed in one stage to  $\frac{1}{2}$  in., it could be reduced to 50-lb. lots with a maximum error of (99/100)  $\pm 0.46$ .

The selected sample is then treated just as in Method (b), i.e. ground to pass a 7-mesh B.S. sieve, etc.

### Sample Dividing

Wherever possible, sample-dividers should be used for the subdivision of samples and the older method of "coning and quartering" by hand should not be used ; the latter is more laborious and the chances of error are greater.

A. *By Sample-Divider.*—A sample-divider is a piece of apparatus designed to split a sample automatically into two or more parts of identical quality, and for practical purposes may be considered satisfactory if the quality of the final sample is identical with that of the gross sample within the limits of error specified.

## Fuel Testing

*The Rifle Sample-Divider*, Fig. 3, consists of a long metal box divided by transverse partitions into several compartments of equal width, the bottoms of the compartments being inclined at an angle of about  $60^\circ$  to the horizontal alternately to opposite sides of the box. Each set of compartments discharges by means of slots in the sides of the box into a separate container, one of which is placed on either side of the divider. Three containers are provided with each rifle-box. When in use, two of the containers are fitted under the outlets from the compartments and the third is charged with coal which is spread evenly. This container is then raised with its front edge resting on top of the divider and tilted so that the coal flows uniformly into all the compartments and thence into the lower containers, the sample thus being divided into two approximately

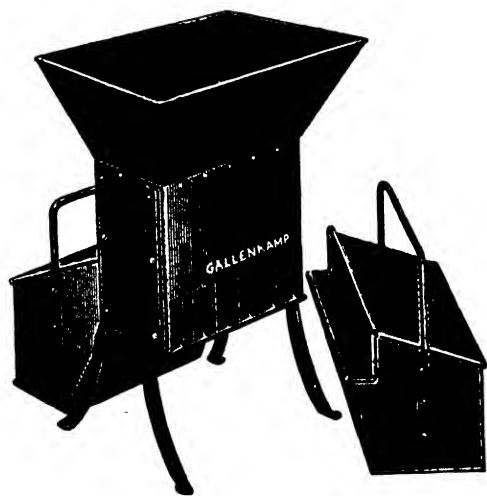

FIG. 3.—Sample Divider. Rifle Type.

(By Courtesy of A. Gallenkamp & Co., Ltd.)

equal portions. The contents of one container are set aside for further division and those of the other are rejected. The process is repeated until all the gross sample has been divided into two halves. The selected half is then passed again through the divider, the division being repeated until the sample has been reduced to the requisite quantity, and in any case to not less than 10 lb.

Other suitable forms of sample-divider are available, and a number are described and illustrated in British Standard Specifications 735, 1937, and 1017, 1942.

Where the reduction is done in stages, the size of the sample-divider should be suited to the size of the coal in each stage.

**B. By Hand.**—The sample is crushed to 2 in. or smaller and thoroughly mixed by heaping into a cone which is turned over to form a new cone, the operation being repeated three times. Each conical heap is formed by depositing each shovelful on top of the preceding one, care being taken to place it on the apex of the cone, so that the portions which slide down the sides of the cone are distributed as evenly as possible, and that the centre of the cone is not displaced.

Alternatively, the cone may be formed with greater ease and accuracy by shovelling the coal into a funnel having a short cylin-

## Sampling

drical stem about 3 in. in diameter. The funnel must be supported vertically above the top of the cone and raised, without lateral displacement, as the cone grows higher to allow the coal to flow out gently and not fall from a height. A new cone is then formed twice in a similar way, care being taken to work steadily round the old cone until it is all transferred.

The third cone is flattened down uniformly by repeated insertions of the edge of a shovel or board along axial planes, working radially round the cone and lifting the shovel or board clear after each insertion. The flattened heap must be of uniform thickness, and its centre must coincide with the centre of the original cone.

The sample is then quartered by marking the heap off into quarters along two diameters which intersect at right angles. This may be done accurately and expeditiously by means of a cross of sheet metal made with four arms or blades joined at the centre, held at right angles to each other by stays, and reinforced along their upper edges. The cross is placed centrally on the heap and the thin lower edges of its blades are pressed into the coal. Each pair of opposite quarters is then shovelled into a separate heap, and one of these heaps is rejected.

Whichever method is used, the operation is repeated until a sufficient quantity is left to provide the required number of samples of the necessary weights. If more than one sample is required, the remaining quantity may be subdivided by means of a sample-divider. Alternatively, the coal may be divided into the requisite number of samples by means of a scoop, an appropriate proportion of each scoopful being dropped into each tray in turn, e.g. for four samples, a quarter of each scoopful would be put into each tray successively in rotation, 1, 2, 3, 4 ; 2, 3, 4, 1 ; 3, 4, 1, 2 ; 4, 1, 2, 3, and so on, so that no tin is filled exclusively with coal from one part of the scoopful. Each tin must be clearly labelled "Sample for Analysis."

### CONTAINERS FOR SAMPLES

(i) *Size*.—Should preferably be such that only one container is required for each sample and that the sample should completely fill the container.

(ii) *Material*.—Must not be porous or liable to corrosion, otherwise moisture may be lost or the sample contaminated.

(iii) *Shape*.—Samples must be easily removed and the container must be capable of being readily cleaned out. The mouth should be wide.

(iv) *Method of Closing*.—Containers must be capable of being sealed to prevent loss of moisture. If lids of metal containers are soldered on, this must be done without heating the contents. Luting

## Fuel Testing

of lids by means of paraffin wax, tallow or pitch is not admissible on account of the risk of contaminating the sample. Metal containers with externally fitting lids are suitable; the lids should be sealed by binding with adhesive tape.

### SAMPLING COAL BY THE SUCTION-DRILL SAMPLING MACHINE

This ingenious method of sampling coal was described by J. C. Vogel, Director of the Fuel Research Institute of South Africa, and consists in drilling into the coal by means of an ordinary electrically

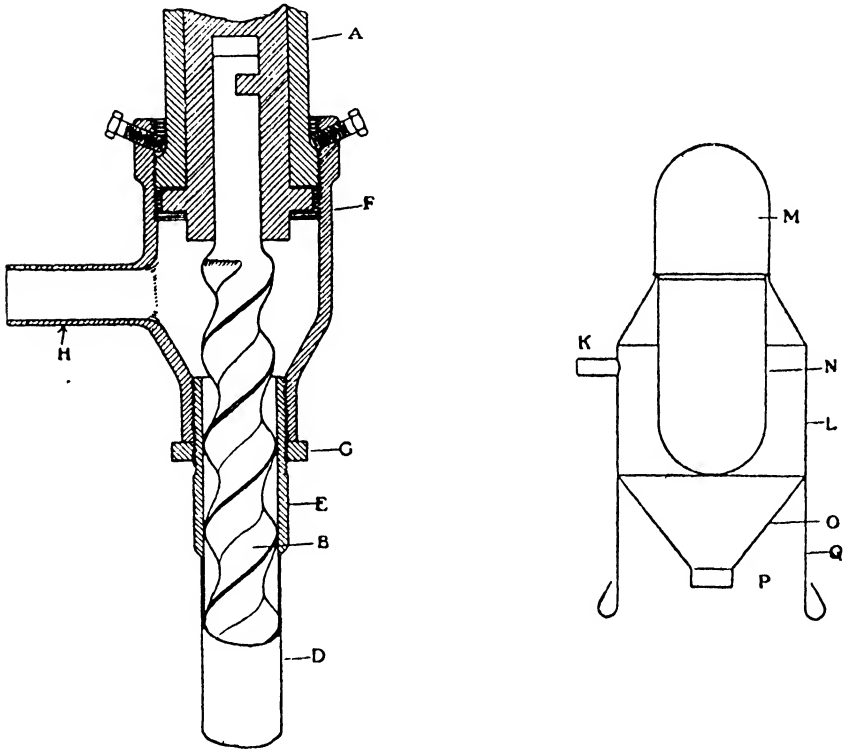

FIG. 4.—Suction-Drill Sampler for Coal.

driven coal drill provided with a tubular casing through which the coal dust and chippings are continuously withdrawn by means of a suction cleaner. Originally devised to enable coal to be sampled at the face by unskilled labour, the method has been successfully applied to coal in piles and trucks, under which conditions, sampling by hand is difficult. Since, however, the gross samples are swept out of the drill by a current of air, results for moisture may be seriously in error.

The apparatus is shown in Fig. 4. It consists of a Siemens-Schuchert enclosed electrical coal drill motor A, working at a speed

## Sampling

of 600 revs. per min., having a detachable spiral drill rod B,  $1\frac{1}{2}$  in. in diameter and tipped with a Widia steel bit having a maximum diameter at the cutting edge of  $1\frac{1}{8}$  in. The drill rod is completely sheathed in a thin-walled steel tube D, of  $1\frac{3}{16}$  in. external diameter, in which the rod can turn loosely, and of such a length that only the cutting edge of the bit projects beyond it. The end of the tube D remote from the bit is brazed into a short length of threaded  $1\frac{1}{2}$ -in. water-pipe E, which can be screwed into a  $1\frac{1}{2}$ -in. to  $2\frac{1}{2}$ -in. reducing union F, which in turn is screwed over the motor housing and firmly fixed thereto by screws. The pipe E is held firmly in position by means of the lock-nut G. The union F is drilled and tapped to take a short length of 1-in. piping H; this is connected by means of a suitable length of rubber hose to the intake K of a "Tellus" industrial pattern suction cleaner, consisting of an electrically driven fan M and a filter bag stretched over a wire frame N, enclosed in an outer container L. The capacity of the container is increased by the addition of a conical bottom O which is provided with an outlet P, which can be enclosed by a bung. For convenience, the suction cleaner is mounted on legs Q.

The apparatus is operated as follows: the point of entry and depth of hole having been decided on, the suction cleaner is switched on, the drill directed against the place chosen, and started. The coal dust and chippings cut out by the bit are carried between B and D, through H and along K into O, where the sample collects. After the hole has been drilled the drill should be allowed to rotate for a short while so as to clear the tube completely. The sample can then be filled into a bag through P. Since the finest dust tends to adhere to the filter cloth it is advisable to shake this thoroughly before removing the sample. The length of drill rod can be varied to suit the occasion, though for sampling at the coal-face a 2-ft. rod was found to be most suitable.

Experiments have been made on South African coals by J. C. Vogel and, subsequently, by L. A. Bushell<sup>3</sup> to ascertain whether the suction method compared satisfactorily with hand sampling when applied to coal in trucks. The following conclusions were drawn: (i) Provided the number of increments is adequate and the increments are evenly distributed over the mass of coal to be sampled, there is no significant difference between the ash on the samples taken by the two methods. (ii) Drill sampling possesses advantages over hand sampling for coal down to  $1\frac{1}{2}$  in. in size; the method may be used for smaller coal, but the drilling must be more carefully done, since the increments become very small. In any case, the ease with which hand sampling of coal below  $1\frac{1}{2}$  in. may be accomplished offsets any advantage to be gained by drill sampling. (iii) The number of increments required may be calculated



## Fuel Testing

from the equation  $R = \frac{0.85a}{\sqrt{n}}$ , where  $a$  = the average error per increment,  $n$  = the number of increments, and  $R$  = the average error as previously defined. (iv) When sampling mixed coal, consisting of round coal plus cobbles, it is advisable to increase the number of increments above that required for pure round coal in a ratio depending on the percentage of cobbles present and the amount of extra impurity introduced by the addition of the cobbles, and a similar procedure is advised for all types of mixed coal. (v) As in all methods of sampling, the positions at which the increments are taken must be evenly distributed over the whole quantity of coal being sampled. (vi) The drill rod should be long enough to enable it to penetrate to the bottom of the coal, and (vii) Since the number of increments required is derived mathematically, it is advisable to take five or ten increments more than the number indicated by the formula.

*Precautions* : (i) To obtain a good increment, the action of the bit must be one of cutting and not rubbing ; the bit must therefore be kept *sharp*. (ii) The suction system must not be allowed to become choked with coal ; the suction cleaner should be carefully tested for leakage of air and during drilling, and care must be taken to keep the connecting piping flat and free from twists ; this is especially important when sampling soft coals which, on account of their softness, frequently cause stoppages owing to the coal being drilled out faster than it can be removed. This can be avoided by drilling more slowly and allowing the tube to clear itself as soon as a large piece of coal is encountered. If a small hole,  $\frac{1}{8}$  in. diameter, is drilled in the outer casing just above the outlet pipe of the sheath, the risk of stoppages is reduced, since the thin stream of air prevents choking of the coal in the hose. A stoppage can be detected at once by a change in the sound of the drill motor, so that no loss of sample need occur. If, however, a stoppage should be detected only after extracting the drill rod, it is advisable to reject the increment and collect a fresh one. (iii) It is important that no unnecessary pressure should be exerted on the drill, especially in sampling small coal ; as far as possible, the drill should be allowed to proceed under its own weight ; pressure should be exerted only when there is difficulty in penetrating the mass of coal.

### *Advantages of Suction Sampling*

(i) The method is applicable to large coal which is difficult to sample by hand, (ii) suction sampling is readily applied to coal in wagons and piles, i.e. while at rest, (iii) the weight of the gross sample is less than required for a hand sample, although the number of increments required is greater, therefore reduction of the sample to the quantity required for test is facilitated and the possibility of

## Sampling

errors during this stage of the process is reduced, (iv) the maximum size of particle in a suction sample is about  $\frac{1}{2}$  in. ; less crushing is therefore required during preparation of the final sample, (v) considerable saving of time is effected as compared with hand sampling, since the time required per sample seldom exceeds 30 minutes, and (vi) the effect of the personal element in sampling is minimised, since the process is mechanical.

### SAMPLING COKE FOR ANALYSIS

The principles underlying the sampling of coke are the same as for coal, but since the most variable constituent is the moisture, the size of the gross sample and the number of increments by which it is taken must be determined by the percentage of moisture in the coke. Experiment has shown that, (i) the average deviation from the mean increases until the moisture is between 8 and 9 per cent., after which it attains a constant value for higher contents of moisture, up to 15 per cent., and (ii) increments must be at least  $2\frac{1}{2}$  lb. if consistent results for moisture are to be obtained.

Unless the moisture is as low as about 1 per cent., the variability of the ash is less than that of the moisture. For coke containing 2 per cent. or less of moisture, the minimum number of increments required for a satisfactory sample has been taken as 20, and this number is sufficient to ensure a satisfactory sample for ash and volatile matter. In all other cases, the number of increments is more than sufficient for correct sampling for ash, etc., and a sample taken to give an accuracy of  $\pm 1$  unit (99/100) on the moisture can be relied on to give a higher degree of accuracy for ash and other constituents.

The general methods of sampling coke are those which are applied to coal, but great care must be taken to avoid loss of moisture by air-drying during any of the stages. Certain variations in details of the methods are referred to below.

A. *Sampling from Wagons.*—Samples taken from the tops of wagons cannot be relied on to be representative if the coke has been exposed to rain or snow, or to the air for some time (particularly a current of air, as during transport). Samples should therefore be taken from the tops of wagons only at the producer's works, and then only if it is certain that the loaded wagons have not been subjected to the above influences.

The requisite number of increments must be evenly distributed over the whole number of wagons in the consignment.

(i) *At the Producer's Works.*—Holes not less than 6 in. deep are dug by hand at a distance from the corners of the wagon equal to about one-sixth of the diagonal and the increments are taken from the bottoms of the holes.

## Fuel Testing

(ii) *At the Consumer's Works.*—The increments are taken from freshly-exposed faces at the full depth of coke in the wagons during unloading.

*Note.*—The effect of very heavy rain may extend half-way down a freshly exposed face of coke in a wagon, and deeper at the sides of the wagon. Transport during fine weather after heavy rain causes loss of moisture in the uppermost layers. Agreement with the values for moisture obtained at the producer's works is more likely if the lower half of the wagon is sampled from a freshly-exposed face at the consumer's works, but to determine the total moisture, increments must be taken from all horizons of freshly-exposed faces. The methods of sampling should always be agreed upon between buyer and seller.

*B, C and D. Sampling from Chutes, Conveyers and Feeding Devices.*—Methods as for coal.

## Size of the Gross Sample

*A. For Ordinary Purposes.* Two classes of coke are considered :—

*Class 1.*—Screened or unscreened coke containing not more than  $7\frac{1}{2}$  per cent. below 1 in., and not more than 5 per cent. of moisture : graded coke (e.g. nuts, cobbles, etc.) when quenched.

*Class 2.*—Other cokes : breeze.

TABLE VIII  
MINIMUM WEIGHTS OF GROSS SAMPLE  
*Increments not less than  $2\frac{1}{2}$  lb.*

Content of Moisture Per Cent.	Class 1.		Class 2.	
	No. of Increments.	Minimum Weight of Gross Sample.	No. of Increments.	Minimum Weight of Gross Sample.
Up to 2	20	50	35	88
2 to 3	44	110	70	175
3 to 4	74	185	120	300
4 to 5	95	238	170	425
5 to 6	112	280*	235	588
6 to 7	118	295*	280	700
7 to 8	126	315*	300	750
Over 8	134	335*	305	763

\* Graded coke only.

*Note.*—If the size of the coke when quenched or the approximate moisture is not known, the coke should be considered as falling in Class 2 unless a lower degree of accuracy is acceptable.

## Sampling

B. *For Special Performance and Efficiency Tests.*—Each class has as far as possible been divided into three groups, according to the moisture, as in Table IX.

TABLE IX

MINIMUM WEIGHTS OF GROSS SAMPLES OF COKE FOR PERFORMANCE AND EFFICIENCY TESTS

Accuracy.	Class of Coke.  Moisture Per Cent.	1.			2.		
		Up to 3.	3 to 6.	Over 6.	Up to 3.	3 to 6.	Over 6.
± 0.25	Minimum no. of increments .	704	Impracticably large		1120	Impracticably large	
	Minimum weight of gross sample	1760			2800		
± 0.5	Minimum no. of increments .	176	448	536	280	940	1220
	Minimum weight of gross sample	440	1120	1340	700	2350	3050
± 0.75	Minimum no. of increments .	68	199	238	125	418	542
	Minimum weight of gross sample	170	500	595	313	1045	1355
± 1.0	Minimum no. of increments .	44	112	134	70	235	305
	Minimum weight of gross sample	110	280	335	175	588	763

Minimum increment 2½ lb.

### Reduction of the Gross Sample

The same precautions must be observed as in reducing the gross sample of coal. Free ventilation of the crushed coke must be avoided, or loss of moisture will occur. Save where the moisture is not being determined, a sample-divider must not be used. Preliminary crushing of the whole sample to pass a ½-in. B.S. sieve should preferably be carried out in a jaw-crusher, but where mechanical crushing cannot be employed, the floor, mortars and other apparatus must be hard, smooth, free from cracks and of such a nature that contamination of the sample cannot occur during crushing. Manganese-steel is recommended. When dealing with large samples, mechanical crushing is essential to prevent loss of moisture.

The sample, after being crushed as above, is quickly mixed on the floor with a shovel, avoiding undue ventilation, scraped into a heap and flattened. If the gross sample much exceeds 50 lb. it is reduced to that amount by taking not less than 50 1-lb. increments from various parts of the flattened heap, care being taken to include material from all parts of the sample. With very large gross samples, it is permissible to collect the 50 1-lb. increments as the coke is

## Fuel Testing

being discharged from the crusher and to place this sample as collected in a covered bin or box.

The sample of 50 lb. is quickly mixed with a shovel, scraped into a heap and flattened. A sample of not less than 2 lb. (or 4 lb. for breeze) is taken by not less than 20 equal increments from various parts of the flattened heap, and the remainder is rejected. This sample is placed in an air-tight container and used for determination of moisture, and after further preparation by hand, for general analysis.

*Note.*—When mechanical crushing is not possible, the whole of the gross sample is crushed to a maximum size (judged by eye) of 1 in., mixed, and a 50-lb. sample is taken as already described. The 50-lb. sample is crushed to a maximum size of  $\frac{1}{2}$  in., and thereafter the procedure is the same as that outlined above.

*Determination of Moisture.*—The sample (of 2 lb. for coke or 4 lb. for breeze) is spread out on tared metal trays which are again weighed. The trays containing the coke are heated in a suitable oven or on a hot-plate, at a temperature not exceeding 200° C. until the weight is constant and the percentage loss in weight is expressed as moisture. The coke may be weighed hot, and the depth of the layer of coke should not exceed  $1\frac{1}{2}$  in. At 200° C., the time required for drying does not generally exceed 3 hours; at 110° C., nine hours are generally necessary.

*Preparation of the Sample for Analysis.*—The dried sample is crushed to pass an  $\frac{1}{8}$ -in. B.S. screen, the crushed sample is scraped into a heap, flattened and a sample of not less than 4 oz. is taken by not less than 10 approximately equal increments from various parts of the flattened heap. For coke-breeze, the dried sample is to be reduced to pass a 14-mesh B.S. (10-mesh I.M.M.) screen before the 4-oz. sample is withdrawn.

The 4-oz. sample is then crushed to pass a 72-mesh B.S. (60-mesh I.M.M.) sieve and bottled for general analysis.

*Note.*—There is serious risk of contamination where hard cokes are crushed finer than  $\frac{1}{2}$  in. It is therefore suggested that a suitably designed cast-iron jaw granulator be used for reduction to  $\frac{1}{2}$  in., and an agate mortar for the final reduction to — 72-mesh: alternatively final crushing may be by impact in a manganese-steel mortar. Methods of reduction should be checked to ensure that the samples are free from contamination.

The most convenient method for hard cokes is:

- (i) Crush mechanically in a jaw granulator to  $\frac{1}{2}$  in. for the moisture sample.
- (ii) Crush from  $\frac{1}{2}$  in. to  $\frac{1}{8}$  in. on a manganese-steel plate, using a manganese-steel maul with a vertical handle.
- (iii) Crush from  $\frac{1}{8}$  in. to — 72-mesh with a manganese-steel mortar and pestle with a handle not less than 4 ft. long.

## BIBLIOGRAPHY

- <sup>1</sup> *J. Ind. and Eng. Chem.*, Jan., 1917.
- <sup>2</sup> British Engineering Standards Association (now British Standards Institution) No. 403, 1930.
- <sup>3</sup> *J. Inst. Fuel*, 1937, **10**, p. 384, and 1937, **11**, p. 50.
- <sup>4</sup> *J. Chem. and Met. Soc. S. Africa*, 1933, **34**, p. 127, and "Fuel," 1936, **15**, p. 48.
- 

The following Publications of the British Standards Institution should also be studied by all responsible for the sampling of coal and coke :

- No. 763, 1937. "Report on the Sampling of Coal with Special Reference to the Size-Weight-Ratio Theory," by E. S. Grumell.
- No. 735, 1937. "The Sampling and Analysis of Coal and Coke for Performance and Efficiency Tests on Industrial Plant."
- No. 1017, 1942. "Sampling of Coal and Coke."

British Standards publications are obtainable from the Secretary of the Association, 28 Victoria Street, London, S.W. 1.

See also "A Decade of Sampling," by E. S. Grumell. *Am. Inst. Min. and Mech. Eng. Technical Publication* No. 1044, 1939.

## CHAPTER II

### THE PROXIMATE ANALYSIS OF COAL

THE behaviour of a coal when heated out of contact with air, especially the amount of "volatile matter" expelled and the quality of the solid residue, gives a valuable indication of its commercial classification and probable fields of utility. The so-called "proximate analysis" affords a means of studying this behaviour and consists in the determination, under specified conditions, of the moisture, the volatile matter and the ash. The proximate analysis is an assay rather than a true analysis, since the results have no absolute significance, but if the assay is carried out in accordance with standard conditions, the results are reproducible and enable the coal to be classified and an opinion to be formed of its quality and probable uses.

The "volatile matter" is not a constituent of the coal, but consists of a complex mixture of gaseous and liquid products resulting from the thermal decomposition of the coal substance; the amount of decomposition and therefore the yield of volatile matter depends on the conditions of heating, particularly the temperature. Therefore, in determining the volatiles the conditions must be carefully standardised and adhered to, since any departure from the standard method will vitiate the results and they will not be comparable with those of other workers.

The terms "volatile hydrocarbons" and "volatile combustible matter" are sometimes used; both are inaccurate and misleading, therefore their use is to be condemned. The volatile matter contains steam, oxides of carbon and other constituents which are not hydrocarbons, besides products of decomposition from the mineral matter in the coal, although the contribution of the mineral matter to the "volatiles" is usually small; the non-committal term "volatiles" is therefore the only one which is justified and should always be used.

## Determination of Moisture on Analysis

### DETERMINATION OF MOISTURE ON ANALYSIS (FINELY GROUND) SAMPLES

*Note.*—Unless otherwise stated, the expression “finely ground” is to be taken to mean coal ground to pass a 72-mesh British Standard Test sieve (= 60-mesh I.M.M.).

Moisture is generally determined by heating a known weight of coal to 105° to 110° C. for one hour (or longer if necessary) and calculating the loss in weight to a percentage. But while coal may be completely dried under these conditions, it is necessary that heating be carried out in an inert atmosphere, since all coals are more or less liable to oxidation at temperatures as low as 105° C.; generally, the higher the oxygen in the coal substance, the greater its liability to oxidation. Oxidation during drying may cause the apparent moisture to be higher or lower than the true moisture; if oxygen is absorbed by the coal substance and retained, the loss in weight of the sample will be less than the weight of moisture driven out by heating. If, on the other hand, the oxygen is first taken up by the coal substance and afterwards expelled as oxides of carbon and water, the loss in weight of the sample will be greater than the loss due to moisture alone.

*Oven Method.*—From 2 to 10 gm. of finely powdered coal are weighed in a shallow weighing vessel provided with a cover, and of such an area that the weight of coal per sq. cm. does not exceed 0.3 gm. The uncovered coal is heated for an hour at from 105° to 110° C., the weighing vessel is then cooled in a desiccator over calcium chloride or sulphuric acid and weighed with the cover on it. Suitable vessels are, (a) glass Petri dishes about 10 mm. deep, (b) shallow silica dishes or metal vessels provided with well-fitting covers, (c) shallow stoppered weighing bottles, or (d) watch-glasses with ground edges held together with a clip.

The oven must be such that a constant and uniform temperature can be maintained; an ordinary laboratory jacketed oven is often used, the jacket being filled with a mixture of glycerine and water in the proportions necessary to give a boiling-point of 105° C., or with toluene, loss of the heating liquid being prevented by a reflux condenser fitted to the steam vent of the jacket. These ovens usually have unlagged copper doors provided with air registers at the bottom, and the temperature near the front of the oven is generally several degrees lower than that in the middle; the door should therefore be lagged to ensure that the front of the oven is maintained within the prescribed limits.

To prevent oxidation of the coal, drying should be carried out in an atmosphere of nitrogen which should be dried and preheated to



## Fuel Testing

105° C. The atmosphere within the oven should be changed four or five times an hour ; in order to reduce the amount of nitrogen required, the free space within the oven should be a minimum. Methods of reducing the free space, and a special oven designed with a minimum of free space, are described and illustrated in Survey Paper No. 44 of the Fuel Research Board and B.S.S. Nos. 1016 and 1017.

A more satisfactory type of oven is one from which the air is removed by a vacuum pump ; the risk of oxidation is thus minimised and the rate of drying is increased. The reduction in pressure within the oven should be from 20 to 25 in. mercury. If an evacuated oven is used, drying is almost always complete in an hour ; with other types of oven, if the coal is wet (moisture over, say, 7 per cent.), a longer period may be necessary ; how long must be determined by experiment.

### DETERMINATION OF VOLATILE MATTER

A satisfactory test must fulfil the following conditions : (a) Control of the temperature must be accurate and simple ; (b) oxidation of the sample during heating and cooling must be prevented ; and (c) complete expulsion of the volatile matter at the selected temperature must be ensured. The standard temperature is 925° C.

### Bone and Silver Process <sup>1</sup>

The particular features which commend this process are : (i) the coal is heated and cooled in contact with its own gas, therefore risks of oxidation are eliminated ; (ii) the apparatus is so arranged that completion of evolution of volatiles can be ascertained to a nicety ; (iii) with coals which decrepitate, the rate of heating may be reduced without vitiating the quantitative results ; (iv) the method is suitable to all coals, whatever the yield of volatiles ; and (v) the carbonised residue is sufficient in quantity for its general characters to be examined.

Notwithstanding these advantages, and in spite of the fact that the method was adopted in British Standard Specification No. 420, 1931, later specifications have reverted to a modification of the " American " or " crucible " method, which is described on page 32.

*Method of Determination.*—About 5 gm. of finely ground air-dried coal are weighed accurately into a small silica tube A (Fig. 5), about 12 cm. long and 1.5 cm. in diameter, closed at one end, which is slid into a larger silica tube B, 30 × 2.5 cm., also closed at one end, so that the open end of the smaller tube is directed towards the closed end of the larger. The mouth of the latter is closed by a cork,

## Determination of Volatile Matter

through which passes a short delivery tube leading into a bottle D, which contains water. The small silica tube is prevented from slipping forward in the larger by a silica rod C. Bottle D is closed by a cork, through which passes the delivery tube from B, and also an inverted U-tube, one end of which dips nearly to the bottom of the empty bottle E.

The apparatus is connected and the silica tubes are slid into an electric or other furnace previously heated and regulated to  $925^{\circ}\text{C}$ ., the temperature being carefully checked by a thermo-junction. The length of the furnace, which is maintained at  $925^{\circ}\text{C}$ ., should be not less than 25 cm.

The furnace, which may be a muffle or a tube furnace capable of holding two or more tubes, should be inclined at  $5^{\circ}$  or  $10^{\circ}$  to the horizontal, so that tarry matter from the coal runs towards the

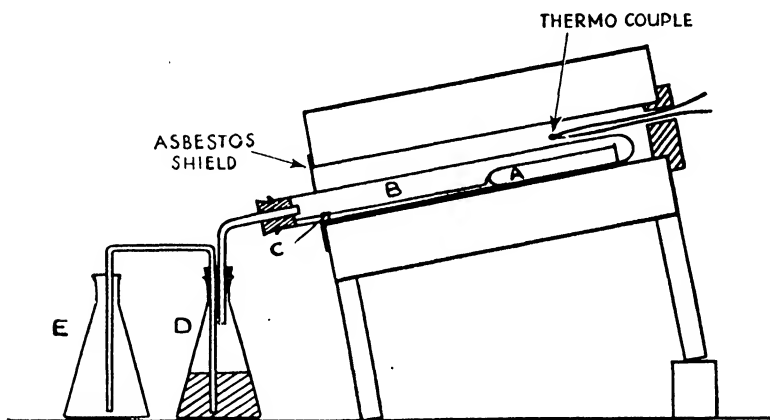

FIG. 5.—Bone and Silver Apparatus.

mouth of the outer silica tube and cannot collect and become carbonised on the outside of the inner tube.

The air displaced from the apparatus and the gas from the coal pass into bottle D, forcing the water into E, and escape via the water-seal thus formed, affording a means of judging when all the volatile matter has been expelled from the coal. When evolution of gas ceases (usually at the end of about 40 minutes), the tubes are carefully withdrawn from the furnace, still attached to the bottles. As cooling proceeds, a certain amount of water should suck back from E into D, proving that the apparatus is airtight. When cool enough to handle, the inner tube is carefully withdrawn, cooled finally in a desiccator and weighed as rapidly as possible. The percentage loss in weight, *minus* the percentage of moisture, gives the yield of volatiles from the coal.

It is advisable to use good bark corks rather than rubber bungs

## Fuel Testing

to close the large silica tube, since rubber softens and leaves a sticky mess at the mouth of the tube, while the bark corks simply char and tend to absorb any tar from the coal: in addition, bark corks are much cheaper.

Duplicate results from simultaneous tests should generally differ by not more than 0.3 per cent., while frequently the difference is less than 0.1 per cent.

The solid residue from the tube should be examined and its appearance recorded; the residue may vary from an entirely non-coherent powder from non-caking coals to the hard, dense coke of the typical strongly caking coals, with innumerable intermediate graduations. Some types of residue obtained in the Bone and Silver test are illustrated in Plates I and II.

1. Jet-black, entirely non-coherent residue from a high-volatile non-caking coal, New Lount Colliery, near Ashby-de-la-Zouch, Warwickshire.

2. Weak, friable jet-black coke from cannel, Hillhouse-igg.

3. Fairly strong coke, showing slight steely lustre from splint coal, Pyotshaw, Clydeside.

4. Very swollen, puffy coke, with much steely carbon from the Silkstone seam, Nunnery Colliery, near Sheffield. This is a gas-coal.

5. Weak, puffy coke, showing much steely carbon, from a coal used in a gas-producer plant, Warrington.

6. Strong, hard, non-porous coke, not swollen, Barnsley 2-ft. bed.

7. Strong, hard, non-porous coke, not swollen, much silvery carbon, typical of a high-class Durham coking coal, Langley Park, Durham. This photograph is on a smaller scale than the others.

8. Strong, rather porous, swollen coke, much steely carbon, from a typical coking coal, Busty "A" seam, Durham.

*Note.*—When describing a coal in the light of the proximate analysis, the term "caking" should be used in preference to "coking," since the latter has an industrial significance. A "coking" coal must necessarily be "caking," but a "caking" coal is not necessarily "coking" in the sense that it may be used for the manufacture of coke.

## Standard Method recommended by the Fuel Research Board and the British Standards Institution

1 gm. of air-dried coal is heated for exactly 7 minutes in a translucent silica crucible of specified dimensions at a steady temperature of 925° C. in a muffle furnace. There are three modifications of the method, A and B for use with coals which decrepitate and for

PLATE I

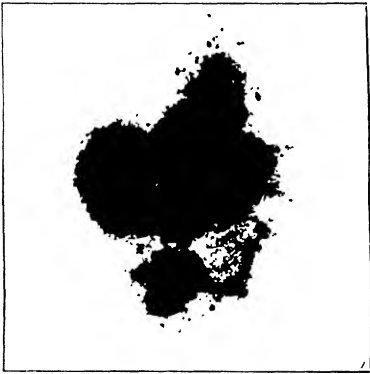

1



2



3



4

[To face page\_32.

PLATE II

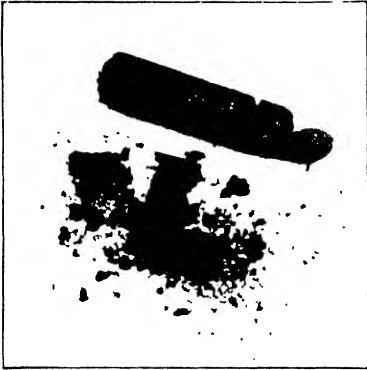

5



6



7

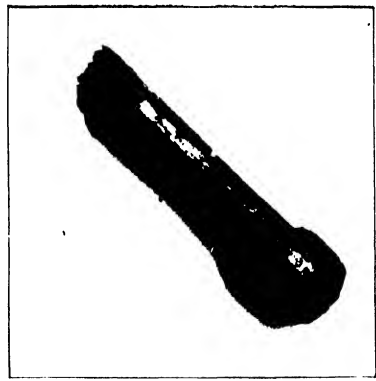

8

## Determination of Volatile Matter

anthracites and non-caking coals of high rank, and C, which is permissible for non-caking coals which yield up to 12 per cent. of volatile matter.

(1) *The Furnace*.—May be heated by gas or electricity, and must provide a steady temperature of 925° C. over the zone to be used. The door should be well-fitting at the front, the back should be closed and fitted with a short flue. The heat capacity should permit of recovery to 910° C. (measured with a standard thermocouple) within 3 minutes from the insertion of a charged crucible into the furnace which had previously been heated to 925° C.

(ii) *Thermo-couples*.—Should be made of metal not thicker than 19 S.W.G. (1 mm.) and should be used with the bare hot junction midway between the base of the crucible and the floor of the muffle. After regulating the temperature of the furnace with a stand and empty crucible in the normal position, the stand and crucible are removed and the furnace is kept closed for several minutes to allow steady conditions to be restored, after which, a charged crucible may be introduced. The thermo-couple is introduced into the furnace through a small hole at the back. A bare junction is not suitable for regular use, since outside influences would change its characteristics; a sheathed couple should therefore be used for routine work. Frequent checking of the sheathed couple against the standard is necessary, and recalibration of the standard thermocouple and of the indicator should be carried out at intervals.

(iii) *Crucible*.—A cylindrical, translucent silica crucible with lid of the capsule type must be used, the dimensions being as follows :—

Crucible.	Lid.
Height 38 mm.	Internal overall diameter 27 mm.
External diameter 25 „	Diameter of well 21 „
Internal diameter 22 „	Depth of well 4 „
Combined weight of crucible and lid 12 to 14 gms.	
Maximum clearance between crucible and lid, at the top edge of the crucible 0.5 mm.	

(iv) *Crucible Stand*.—A Universal fireclay gas mantle support, holding one crucible.

*Standard Procedure*.—1 gm. of air-dried coal is weighed into the crucible and spread in an even layer; the lid is fitted and the crucible is placed on the stand. The crucible and stand are transferred to the furnace, which should be at 925° C., and the door of the furnace

## Fuel Testing

is closed. After exactly 7 minutes, the crucible is removed and placed on a cold iron plate to ensure rapid cooling, thus avoiding oxidation of the contents. The crucible, while still warm, is transferred to a desiccator standing at the side of the balance, and when cold, is weighed. The loss in weight is calculated to a percentage on the coal, the percentage of moisture is deducted, the final result being "volatiles less moisture."

*Modification A.*—This is concerned solely with ensuring a lower rate of heating; it consists in placing two discs of asbestos, each 25 mm. diameter and 1 mm. thick, on the inner projections of the legs of the stand, and resting the crucible on the discs. In all other details the standard method is followed.

*Modification B.*—The principle is to prevent loss by entrainment and decrepitation by the formation of a coherent button of coke by mixing a caking coal with the non-caking sample. The caking coal should yield about 25 per cent. of volatile matter; higher volatiles lead to increased mathematical errors.

0.8 gm. of the coal to be tested is mixed with 0.2 gm. of the caking coal, whose volatiles (including moisture) have been determined by the standard method, and the volatiles of the mixture are determined.

If  $V_0$  = percentage loss in weight (including moisture) of the caking coal,  $V_1$  = percentage loss in weight of the mixture, then

$$V = \frac{5V_1 - V_0}{4}.$$

To obtain the required figure for volatiles, it is only necessary to deduct from  $V$  the percentage of moisture in the non-caking coal.

*Alternative Method C.*—About 1 gm. of the coal is heated to 925° C. for 7 minutes in a current of nitrogen which has been freed from oxygen by being passed over charcoal at 925° C., and then through alkaline pyrogallol solution, and finally dried by passage through concentrated sulphuric acid.

## DETERMINATION OF ASH

About 1 gm. of finely powdered coal is weighed in a porcelain or silica dish, approximately 1 cm. deep by 5 cm. diameter. The dish is placed in a muffle furnace at room temperature, heated to 400° to 450° C. in 30 minutes, and this temperature is maintained for 30 minutes, after which the incineration is completed by heating for one hour at 775° ± 25° C. It is convenient to employ two furnaces, since the time of heating is thereby reduced. The Fuel Research Board have found that by employing this two-stage heating better

## Reporting the Proximate Analysis

agreement is obtained than when more rapid heating is adopted, decrepitation is reduced, and sulphur compounds tend to be decomposed before the sulphur-retaining bases in the ash become very active. As a result, figures for the non-combustible sulphur are more consistent. Several determinations (preferably not more than six) may be carried out simultaneously, provided that the furnaces are capable of heating each dish to about the same temperature. Free circulation of air through the furnaces must be secured; adequate and even ventilation may be obtained by leading the gases away to a short flue rising from a slit across the whole width of the top of the rear door of the furnace. The front of the muffle is best fitted with a sliding door, which is opened to a distance of  $\frac{1}{4}$  in. during incinerations. Excessive ventilation is undesirable, since there is a tendency to mechanical loss with light ashes. When it is necessary to open the front door to remove the dishes, the flue should be closed to prevent mechanical loss in an excessive current of air.

At no time during incineration should the dishes be covered; covering a dish during incineration leads to the fixation of more sulphur in the ash, and hence to irregular results. After the incineration, the dishes are allowed to cool in a desiccator at the side of the balance and when cool, they are weighed. It is desirable to cover the dishes before they are put into the desiccator, since the rush of air into the desiccator when it is opened sometimes causes light ash to be blown away. Similarly, where two furnaces are used, it may be advisable to cover the dishes during transfer.

If incomplete combustion is suspected, the incineration should be repeated until the weight is constant.

*Note.*—Since the moisture in coal varies with the humidity of the atmosphere, determination of moisture should be carried out on each day on which any other tests are to be made.

### REPORTING THE PROXIMATE ANALYSIS

In reporting the results of the proximate analysis, it is necessary to give the moisture on the sample as received, since full data should always be given so that the results may be calculated to the "as received" basis. The report may be drawn up as follows:

#### ANALYTICAL REPORT.

Serial No. 1963.

Sample Marked.—Kailan Special slack coal, representing a consignment of 2000 tons received July 28th to August 6th, 1921.

Sample Received.—6/8/21.

Reported.—8/8/21.

Moisture on the Coal as received, 6.5 per cent.



## Fuel Testing

### Analysis of Air-Dried Coal

	Per Cent.
Moisture * . . . . .	1.4
Volatile matter, less moisture * . . . . .	31.1
Fixed carbon (by difference) . . . . .	51.8
Ash . . . . .	15.7
	100.0
Sulphur in ash † . . . . .	0.1
Combustible sulphur † . . . . .	0.7
	0.8
Calorific value (gross) :	
(a) on air-dried coal . . . . .	12,460 B.Th.U.s. per lb.
(b) on coal as received . . . . .	11,820     "     "
Colour of ash . . . . .	Light brown.
Character of coke . . . . .	Dark grey and lustrous; non-swollen and non-porous. Very hard and strong.

Remarks :     \* Method of determination should be stated.  
                   † For determination of sulphur in ash, see p. 61.  
                   ‡ For determination of sulphur, see p. 53.  
                       For determination of calorific value, see Chapter V.

#### INTERPRETATION OF THE PROXIMATE ANALYSIS

As a basis for comparison and classification of coal, the results are calculated to the dry ash-free coal, the variables being reduced from four to two, adventitious moisture and ash being left out of consideration. In other words, for purposes of comparison and classification, coal is considered to be made up of :

Coal substance, or "dry ashless coal" Moisture Ash	{ Volatile matter Fixed carbon
Total . . . 100 per cent.	100 per cent.

Hence, the volatile matter on the dry ashless coal

$$= \frac{\text{Volatiles as determined} \times 100}{\text{Volatiles} + \text{Fixed carbon}}$$

## Interpretation of Proximate Analysis

The so-called "fixed carbon" consists of mixtures of compounds of unknown constitution, of carbon, hydrogen, nitrogen, sulphur and oxygen, and must be carefully distinguished from the "carbon" found in an ultimate analysis. Since the volatile matter contains compounds of carbon, the fixed carbon is always lower than the total carbon in the coal as determined by combustion analysis.

The following is a convenient commercial classification of coal based on the proximate analysis. Generally speaking, the connection between the volatile matter and the caking characteristics will apply with few exceptions to the coals of Great Britain, although some of the Welsh and Scottish coals do not fall in with it.

TABLE X

CLASSIFICATION OF COAL BASED ON THE PROXIMATE ANALYSIS

Coal.	Approx. Normal Mine Moisture.	V.M. at 900° C. on Dry Ashless Coal.	Caking Characteristics.	Uses.
Anthracite .	2-3	Under 8	Non-caking .	Domestic and central heating. H o p - dryers, m a l t i n g kilns. Small gas-producers.
Anthracitic .	3-6	8-16	Non-caking .	Steam raising. Gas producers.
Semi-bituminous	3-6	15-20	Non- or feebly caking	Steam raising.
Hard coking .	3-6	17-30	Dense coke .	Manufacture of metallurgical coke.
Gas coals .	3-6	30-36	Strong . .	Gas-making. Sometimes for manufacture of metallurgical coke.
Gas coals .	3-10	35-40	Weak . .	Gas-making, gas-producers. Domestic.
Furnace coals. Long-flame .	5-15	40-45	Non-caking .	Reverberatory furnaces. Domestic.
Brown coals and lignites .	15-60	Over 45	Non-caking .	—

## Fuel Testing

### THE CAKING POWER OF COAL. DETERMINATION OF THE AGGLUTINATING VALUE

The suitability of a coal for specific industrial uses is determined largely by the nature of the solid residue which it leaves on carbonisation ; thus a coal which gives an incoherent or very weakly caked residue is obviously unsuited for the manufacture of metallurgical coke, while coals which give strong non-porous cokes are unsuitable for firing boilers or for use in gas-producers.

Some measure of the caking or agglutinating power of coal is therefore required, so that coals may be compared on a quantitative basis. Although comparison of the residues obtained in a Bone and Silver test affords useful information to the experienced eye, the results can be expressed only somewhat vaguely as "coke intermediate between Busty 'A' and Barnsley 2-ft. bed," which, while comprehensible to those familiar with the particular coals, conveys very little information to anyone who has no experience of them. This difficulty may be avoided if the caking power can be expressed quantitatively, whereby a definite number is associated with a defined agglutinative power, so that all coals bearing the same number have the same, or nearly the same, caking properties.

It might be thought that a simple basis would be to compare the crushing strengths of coke samples made from different coals when carbonised in the laboratory, but this is not so. Under these conditions, a high-grade coking coal, such as that from the Busty seam, will produce a specimen of coke which is highly swollen, and which by reason of the large gas-cells has but a low crushing strength, whereas a coal which, in practice, gives a weaker coke, may, in the laboratory, give a much more compact coke of greater crushing strength. The fact is that conditions of heating in the laboratory and in the coke-oven are very different, largely on account of the much smaller mass/surface ratio in the small-scale test, so that heating in the laboratory is much faster than in an oven, and the cokes produced are by no means comparable.

Numerous tests have been described, and an excellent summary is given by J. T. Burdekin,<sup>2</sup> and a comparison of various methods has been given by L. Slater.<sup>3</sup> Campredon<sup>4</sup> determined a "caking index" which was expressed as the maximum weight of sand which could be bound into a solid button of coke by 1 gm. of coal, both coal and sand being ground to definite sizes. J. T. Dunn,<sup>5</sup> and, later, F. S. Sinnatt and A. Grounds<sup>6</sup> drew attention to the possible risks of obtaining a false figure when using sand as the "inert" material, since fluxing sometimes takes place between the sand and the mineral matter in the coal, which results in an enhanced binding effect. Dunn recommended the substitution of anthracite for the

## The Caking Power of Coal

sand, while Sinnatt and Grounds suggested using electrode carbon (not "flame arc" carbon, which contains salts of sodium and calcium), which is practically free from mineral matter, and which gives no volatile matter on heating.

T. Gray, T. H. P. Heriot and W. J. Skilling<sup>7</sup> drew attention to the fact that it is necessary to take into account the amount of incoherent powder which is formed when carrying out a Campredon or modified Campredon test, and they adopted a procedure which has subsequently been adopted with slight modification by the Fuel Research Board and by the British Standards Institution.<sup>8</sup> The general method is to carbonise 25-gm. charges of sand and coal in varying proportions at 900° C., until a mixture is found which gives a coke which will just support a 500 gm. weight, and at the same time not give more than 5 per cent. of incoherent powder (calculated on the original weight of the mixture) in the carbonised residue. The proviso as to the permissible limit of loose powder is necessary since it is found that as the percentage of sand in the mixture is increased, more and more loose powder is found in the residue, and the coherent portion becomes progressively less. In one example quoted, although 50 per cent. of the carbonised residue was a loose powder, the solid portion would still support a 500 gm. weight. The arbitrary limit of 5 per cent. of powder was therefore adopted, and all comparisons are made on this basis.

(i) *The Furnace*.—May be heated by gas or electricity and must be capable of maintaining a steady temperature of 900° ± 15° C., and provided with a closely fitting door. The heat capacity must be such that the temperature of 900° C. is regained before the end of the 7-minutes' test. The temperature should be determined by a suitable insulated thermo-junction, the hot junction being placed away from the floor and sides of the furnace in the position subsequently to be occupied by the crucible.

Crucible.	Lid.
Internal diameter at top, 38 ± 1 mm. External diameter at bottom, 26 ± 1 mm.	Minimum width, 46 mm. Maximum width, including extension to facilitate handling, 60 to 62·5 mm.
Height, 42 ± 0·75 mm.	Thickness, about 1·5 mm.
Radius of curvature, rounded edge of bottom, 3·5 mm.	Diameter of recessed part of lid, 36 mm. Depth of recess, 3 to 4 mm.

## Fuel Testing

(ii) *The Crucible*.—Should be of translucent silica and conform to the above dimensions.

(iii) *A Solid Rubber Bung*.—

Diameter, narrow end	.	.	.	1 $\frac{3}{8}$ in.
„ wide	„	.	.	1 $\frac{3}{8}$ „
Height	.	.	.	1 $\frac{1}{4}$ „

(iv) *The Sand*.—Should consist mainly of angular particles of pure silica, and should be free from impurities such as clay, chalk, or siderite. It should be graded to pass a 52-mesh B.S. sieve and to remain on a 72-mesh B.S. sieve. It should contain not more than 5 per cent. of oversize, or about 10 per cent. of undersize. The undersize or oversize material should not be appreciably smaller or larger than the specified screen sizes. It should not break down on heating for three hours at 920° C. to such an extent that the percentage of undersize material is increased by 2.5 per cent. It should not be soluble in hot dilute hydrochloric acid to a greater extent than 0.5 per cent. Sand prepared solely at the Fuel Research Station should be used.\*

*Procedure*.—The requisite quantities of sand and finely ground coal to give exactly 25 gm. of the required mixture are weighed into a tared, stoppered weighing-bottle. A suitable bottle is 3 in. high and 1 in. diameter. The sand and coal are thoroughly mixed by means of a spatula and transferred to the crucible, the bottle being continuously rotated during the process. The constituents are again mixed in the crucible and the surface of the mixture is smoothed by pressing gently with the narrow end of the rubber bung, care being taken to prevent shock or jarring.

The crucible is covered with the lid and placed on a silica triangle, the ends of which are bent down to form legs, so that the bottom of the crucible is 1 cm. above the bench. The stand and crucible are gently transferred to the furnace, previously heated to 900° ± 15° C. and the door is closed. After exactly 7 minutes the crucible and stand are removed and placed on asbestos boards and allowed to cool to room temperature. After 30 minutes the crucible is taken from the stand and the lid is removed. The rubber bung is gently inserted so that the narrow end rests on the carbonised mixture, and the crucible and bung are inverted on a sheet of white glazed paper on which any loose particles should be collected. The crucible is slowly and vertically removed from the carbonised mixture; the coherent residue is removed from the bung, care being taken to avoid fracture or abrasion, and the residue is placed on a level

\* Standard sand may be obtained from the Director of Fuel Research, Fuel Research Station, River Way, Blackwall Lane, East Greenwich, in 7-lb. bottles, 23s., carriage free within the United Kingdom.

## The Caking Power of Coal

surface, resting on its broad end. A 500-gm. weight is gently lowered on to the carbonised residue. If the residue withstands the load, the loose powder from the top of the bung is added to the powder on the paper and weighed on a watch-glass.

The test is repeated with mixtures of different ratios of sand and coal (25 gm. of mixture always being used) until consecutive whole-number ratios are found in which the mixture of the lower ratio gives a coherent residue which supports a 500-gm. load, with less than 1.25 gm. of dust, and the mixture of the higher ratio fails to give a coherent residue, or gives a residue that crumbles beneath the 500-gm. load, or gives more than 1.25 gm. of dust. The lower ratio is the agglutinating value of the coal.

Gray, Heriot and Skilling (*loc. cit.*) give the following illustration of the results of a series of tests :

Serial No.	Ratio Sand to Coal.	Loose Powder.	Weight Supported. Gm.	Index Adopted.
46	14	1.7	1000	21
	16	2.0	1000	
	18	3.9	1000	
	20	3.9	1000	
	21	4.8	500	
	22	6.0	500	
	24	6.9	--	

Surprisingly close agreement was found between the caking index and the practical estimate of the value of the cokes from Scottish coals determined by means of bag-tests in a coke-oven. The following connection between the caking index and the coking properties of 367 Scottish coals was found to hold :

	Caking Index.
Coals suitable for the manufacture of coke . . . . .	16 and over
Coals possibly suitable for the manufacture of coke	15
Coals suitable for blending . . . . .	12 to 14
Coals possibly suitable for blending . . . . .	11
Coals unsuitable for the manufacture of coke . . . . .	Below 11

## Fuel Testing

### THE SWELLING PROPENSITY OF COAL. CRUCIBLE TEST

The test is designed solely to provide a comparative measure of the tendency of a coal to swell when carbonised ; other routine tests, although they give some indication of the swelling propensity, are designed primarily for other purposes, and are not sufficiently discriminating. The test is based on one devised in the laboratories of the Woodall-Duckham Companies (*Gas Journ.*, Nov. 9th, 1925, Coke Competition Number, p. 15), and has subsequently been standardised by tests carried out on a wide variety of coals in a number of laboratories.

The reproducibility of the results has been shown, by a consideration of the average error, to be such that the mean result of four tests on the same sample of coal is correct to within  $\pm 1$  unit in 99 cases out of 100, and within  $\pm 0.5$  unit 80 times in 100.

*Apparatus.*—(i) Transparent silica crucible, squat shape, with silica lid with ring handle. The crucible must comply with the following :

Weight, from 11 to 12.75 gm.

Height, 26 mm.  $\pm 0.5$  mm., external.

Diameter at top, 41 mm.  $\pm 0.75$  mm., external.

Diameter at base, not less than 11 mm.

Capacity should be approximately 17 ml.

(ii) A triangle, consisting of translucent silica tubing, 6 to 6.5 mm. external diameter, mounted on chrome-nickel wire, the length of the side being 63 to 64 mm., and the diameter of the inscribed circle approximately 32 mm.

(iii) Teclu burner,  $\frac{1}{2}$  in. diameter.

(iv) Draught shield made from asbestos cement piping, approximately 6 in. long and 4 in. internal, and  $4\frac{3}{8}$  in. external diameter. The piping has three slots at one end, 1 in. deep, in which the wire portions of the silica triangle rest (Fig. 6).

The supply of gas and air to the Teclu burner are adjusted to give a flame approximately 12 in. long ; with the burner thus adjusted, the position of the crucible, when resting on the silica triangle and supported in the draught shield, is arranged so that the temperature of the inner surface of the bottom of the crucible reaches  $800^{\circ} \pm 10^{\circ}$  C. in  $1\frac{1}{2}$  minutes and  $820^{\circ} \pm 5^{\circ}$  C. in  $2\frac{1}{2}$  minutes from first igniting the gas. With coal-gas of 500 B.Th.U.s. and with a flame 12 in. long, the correct conditions of heating are usually attained when the base of the crucible is just above the tip of the blue cone. The conditions of heating must be checked frequently

## Swelling Propensity of Coal

by means of a fine wire thermo-couple inserted through a pierced lid, and having its unprotected junction in contact with the centre of the base of the empty crucible. The couple should be made of wires not heavier than 34 gauge (platinum) or 26 gauge base metal, and the end of the couple should be a flattened loop, so that the

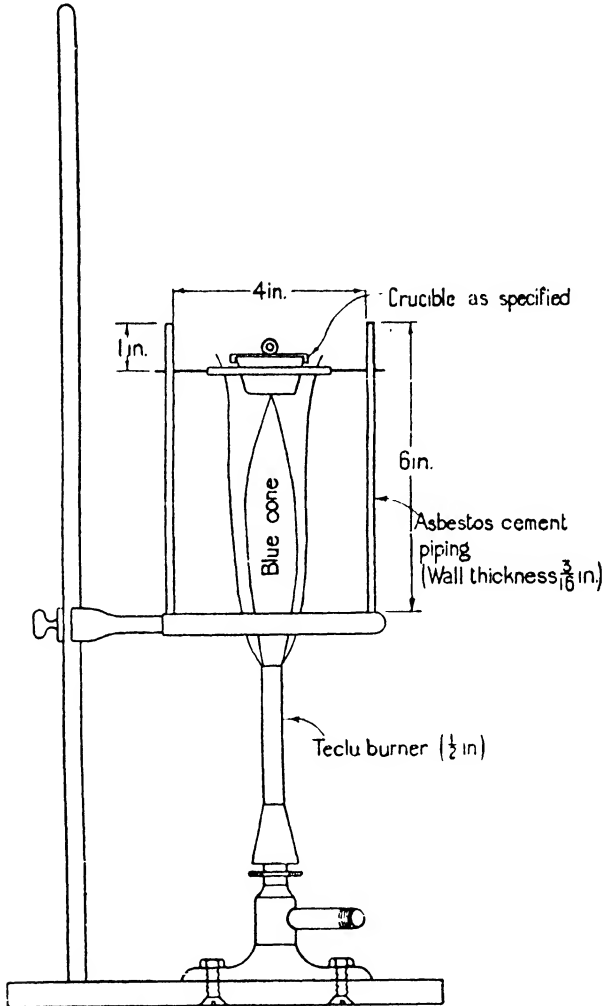

FIG. 6.—Apparatus for Determining the Swelling Propensity of Coal.

(Extracted, by permission, from B.S. No. 804, 1938.)

junction and a portion of each wire rests on the bottom of the crucible during measurement of the temperature.

*Method of Test.*—1 gm. of the finely ground, air-dried coal is weighed in the crucible, which is then lightly tapped twelve times on the bench to level the surface of the coal. The crucible is covered with the lid and placed upright on the silica triangle supported in



## Fuel Testing

the draught shield. The gas is lighted and the crucible is heated until the flame from the burning volatiles dies out, but in any case for not less than  $2\frac{1}{2}$  minutes. The crucible is then cooled, the button of coke is carefully removed and compared with the standard

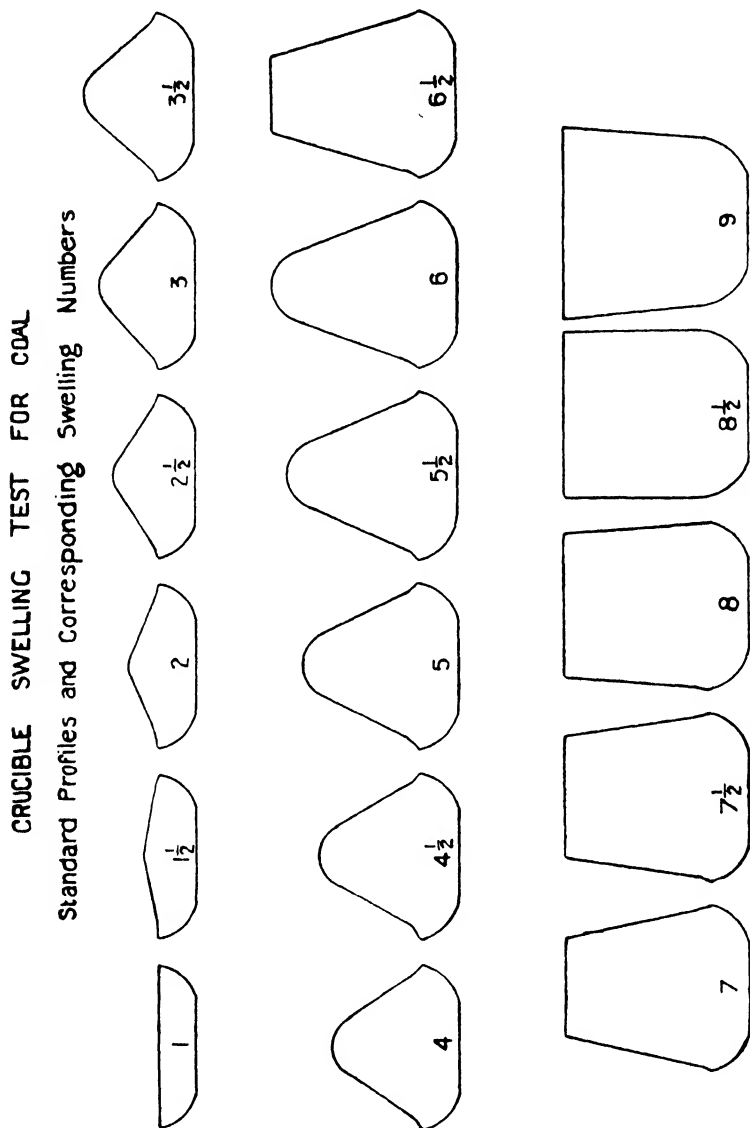

FIG. 7.—Silhouettes of Coke Buttons in Swelling Test.  
(Extracted, by permission, from *B.S. No. 804, 1938.*)

numbered outlines in Fig. 7. When making the comparison, the button must be rotated about its axis so that the largest profile is presented to view. The test is repeated until four buttons have been obtained. After each test, the carbon residue in the crucible is removed and the interior of the crucible is wiped clean.

## Proximate Analysis of Coke

Since the swelling propensity of coal alters during storage, if the sample cannot be tested immediately, it should be retained in a coarse condition and ground immediately before the test. The date on which the sample was taken and that on which the test was made should be given in the report.

*Method of Reporting.*—The swelling number of a button is the number inscribed in the outline that its largest profile most nearly matches, and the mean swelling number of the series of four tests, expressed to the nearest half unit, is reported.

If a powder is obtained or a button is non-swollen (i.e. swelling number = 1) and will not bear a 500-gm. weight without crumbling, the coal is described as “non-agglomerating.” If the button merely cracks into a few firm pieces, the coal is distinguished as “agglomerating.”

*Note.*—To avoid parallax when examining the buttons, it is suggested that the button be viewed through a vertical glass tube, 10 in. long and  $1\frac{1}{2}$  in. internal diameter, held in a clamp so that the bottom end of the tube is 3 in. above the bench. The drawing, with which the button is to be compared, is placed exactly central in the field of vision from the top of the tube, and the button is then rotated until the maximum cross-section is in line with the drawing when one eye is placed immediately over the top of the tube.

It is important that the proportion of very fine coal (passing a B.S. 240-mesh sieve) should not be excessive. The screen analysis of the sample should approximate to :

— 72 + 120-mesh B.S. sieve	. . . . .	35 per cent.
-- 120 + 240- .. .. .	. . . . .	30 ..
— 240- .. .. .	. . . . .	35 ..

This may be secured as follows :—

(a) With an end-runner mill, grind 5 minutes, screen over 72-mesh B.S. sieve, return the over-size to the mill and grind for 5 minutes. Repeat until 98 per cent. of the coal has passed the 72-mesh sieve. The remainder is ground by hand to pass the 72-mesh sieve, and the sample is then thoroughly mixed.

(b) With a coffee-mill grinder, the mill must not be closely set, and after each passage through the mill, the coal is screened on a 72-mesh B.S. sieve, the over-size being re-ground until 98 per cent. of the sample has passed the 72-mesh sieve. The remainder is ground by hand to pass the sieve, and the sample is then thoroughly mixed.

## PROXIMATE ANALYSIS OF COKE

### DETERMINATION OF MOISTURE

#### On the Sample for Analysis

As for coal, except that the precautions to exclude oxygen from the oven are not required.

# Fuel Testing

## DETERMINATION OF VOLATILE MATTER

The standard temperature for the determination of volatile matter in coke is  $950^{\circ}\text{C}$ . Since the quantity of volatile matter from the coke is insufficient to displace oxygen from the apparatus, the ordinary procedure followed for coal is unsatisfactory; and either means must be taken to add a volatile material which will prevent oxidation of the coke, or heating must be carried out in an atmosphere of nitrogen.

### Standard Method, Modification A (p. 34)

From two to four drops of benzene are added to the 1 gm. of coke and the temperature is raised to  $950^{\circ}\text{C}$ . The benzene vapour displaces the air from the crucible, thus preventing oxidation.

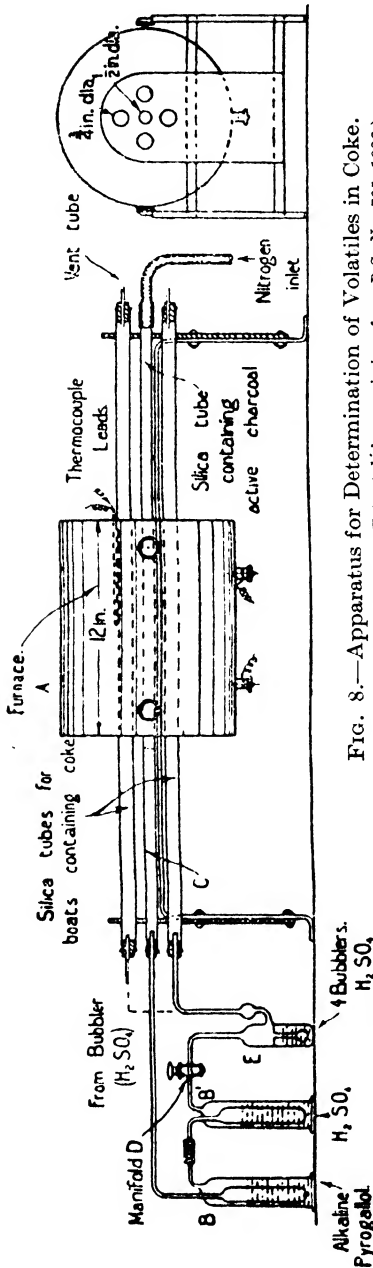

FIG. 8.—Apparatus for Determination of Volatiles in Coke.  
(Extracted, by permission, from *E.S.* No. 705, 1936.)

### Alternative Method C

Apparatus suitable for four simultaneous determinations is shown in Fig. 8. The furnace A, 12 in. long, is specially wound to take four silica tubes  $\frac{3}{4}$  in. diameter and one central tube of 0.5 in. diameter. Nitrogen from a cylinder is passed through the central tube C which contains activated carbon to remove the last traces of oxygen, then through two wash-bottles B and B' which contain respectively alkaline pyrogallol and concentrated sulphuric acid. The stream is then divided at the manifold D and passes to any

or all of the four tubes through small bubblers E (containing

## Determination of Ash

concentrated sulphuric acid) which serve to indicate the rate of flow.

One-gm. portions of the samples are weighed in porcelain boats and introduced into the silica tubes, which are heated to 600° C., or to 400° C. if the samples tend to decrepitate. The temperature of the furnace is raised to 950° C. during a period of 40 minutes, and maintained at this temperature for exactly 7 minutes. The furnace is then moved so as to uncover the boats, which are allowed to cool, the rate of passage of nitrogen being slightly increased from the normal two bubbles per second to avoid the possible inleakage of air. When cool, the boats are transferred to a desiccator which is stood at the side of the balance case for 10 minutes, after which the boats are weighed. The determination may be made either on air-dried or on dried coke.

### DETERMINATION OF ASH

This is determined by burning about 1 gm. of the air-dried coke, spread in a thin layer, in a muffle furnace at  $775^{\circ} \pm 25^{\circ}$  C.

### BIBLIOGRAPHY

Fuel Research Board, Survey Paper No. 44, 1940. "Methods of Analysis of Coal and Coke."

British Standard Specification No. 1016, 1942.

<sup>1</sup> W. A. Bone and L. Silver, *Journ. Chem. Soc.*, 1921, **109**, pp. 1145-53.

<sup>2</sup> J. T. Burdekin, Fuel Research Board, Survey Paper No. 8, 1926.

<sup>3</sup> L. Slater, Fuel Research Board, Report for Year Ending March 31st, 1929.

<sup>4</sup> L. Campredon, *Comptes Rendues*, 1895, **121**, p. 820.

<sup>5</sup> J. T. Dunn, *Journ. Soc. Chem. Ind.*, 1913, **32**, p. 397.

<sup>6</sup> F. S. Sinnatt and A. Grounds, *ibid.*, 1920, **39**, p. 83T.

<sup>7</sup> T. Gray, T. H. P. Heriot and W. J. Skilling. Fuel Research Board Survey Paper No. 15, 1929.

<sup>8</sup> British Standard Specification No. 705, 1936.

## CHAPTER III

### THE ULTIMATE ANALYSIS OF COAL <sup>1, 2</sup>

THE object of carrying out the ultimate analysis of coal is to determine the elementary composition of the organic matter, namely, the proportions of carbon, hydrogen, nitrogen, sulphur and oxygen; this is accomplished by suitable modifications of the methods used for organic substances.

#### DETERMINATION OF CARBON AND HYDROGEN

These elements are determined by burning a known weight of finely powdered dried coal in a stream of oxygen, complete combustion being ensured by passing the gaseous products over red-hot copper oxide, the water and carbon dioxide formed being weighed.

The apparatus consists of a purifying train in duplicate, for oxygen and air, a combustion tube heated in a suitable furnace, and the necessary absorption tubes for collecting the water and carbon dioxide formed.

Each purifying train consists of two glass towers, the first packed with Sofnolite (special soda-lime) and the second with calcium chloride. The trains are connected in parallel to a two-way tap, so that either dry air or dry oxygen, as required, may be supplied to the combustion tube. Between the two-way tap and the combustion tube, a small bubbler containing concentrated sulphuric acid is introduced; this enables the rate of passage of air or oxygen to be observed and assists in the control of the experiment.

The combustion tube should be of resistance glass or silica, 1 metre in length and 15 mm. internal diameter; the Author uses translucent silica tubes, each provided with two windows of transparent silica, 10 cm. long. One window is fused into the tube 16 cm. from the end which is connected to the purifying train, and the other forms the exit end of the tube. The first window permits the combustion of the coal in the boat to be observed, while the latter allows the analyst to see that all condensed steam has been driven out from the tube at the end of the combustion.

## Determination of Carbon and Hydrogen

Starting at the end connected to the purifying train, the contents of the tube are as follows :

5 cm. space ; 8 cm. oxidised copper gauze spiral, fitted with a loop of thick wire for convenient withdrawal ; 12 cm. space for combustion boat ; 45 cm. granular copper oxide, screened between 7- and 14-mesh B.S. sieves, held in position by rolls of oxidised copper gauze 1 cm. long ; 10 cm. granular, fused lead chromate (to remove compounds of sulphur from the gases), followed by a roll of copper gauze 1 cm. long ; 5 cm. silver spiral, to remove halogen compounds from the gases ; 8 cm. space.

Connection between the two-way tap of the purifying train and the combustion tube is made by india-rubber tubing attached to a

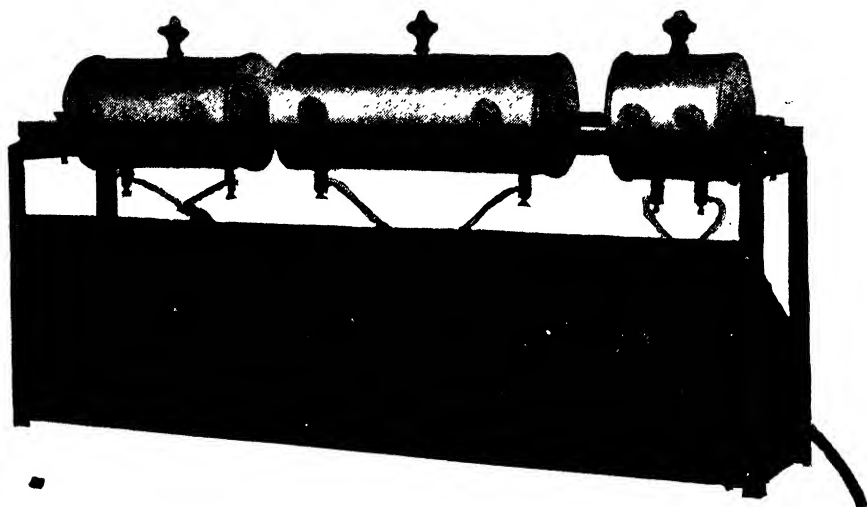

FIG. 9.—Electric Combustion Furnace for Carbon and Hydrogen.

(By courtesy of A. Gallenkamp & Co., Ltd.)

glass tube of  $1\frac{1}{2}$  to 2 mm. bore passing through a well-fitting rubber stopper.

Any good combustion furnace may be used, the essential features being that it should be capable of maintaining the copper oxide section of the tube at  $800^{\circ}$  C., and that control of the temperature of the other section of the tube should enable the lead chromate to be kept at about  $600^{\circ}$  C., while the section containing the boat must be capable of being *gradually* raised to a full red heat. The Author prefers to use an electrically heated furnace such as that illustrated in Fig. 9. This furnace is made in three sections, the temperature of each of which is capable of accurate and ready control.

The absorption train is connected directly to the end of the combustion tube by a well-fitting rubber stopper, and is made up,

## Fuel Testing

in the order named, of (a) a U-tube charged with granular calcium chloride, (b) two U-tubes containing Sofnolite, with about an inch of calcium chloride on top of the Sofnolite in the exit limb to prevent loss of moisture, and (c) a small bubbler containing concentrated sulphuric acid. The bubbler serves to prevent back-diffusion of moisture into the apparatus, and also provides a means for observing the rate of passage of gas.

Before use, the combustion tube is heated in a current of oxygen, the copper oxide section being maintained at  $800^{\circ}\text{C}$ . and the lead chromate section at  $600^{\circ}\text{C}$ . ; if the absorption train does not increase in weight by more than 0.5 mgm. in half an hour, the apparatus may be considered in proper condition for use.

*Procedure.*—From 0.2 to 0.3 gm. of finely powdered dried coal is used for each combustion, spread out in an even layer over the bottom of a boat of porcelain, silica or platinum, about 8 cm. long. The empty boat is weighed in a tightly stoppered weighing bottle, the required quantity of dried coal is transferred to the boat, which is then re-weighed, heated for about half an hour in a vacuum oven, cooled in a desiccator, and weighed again. This final drying is particularly necessary when working with immature coals (brown coals and lignites) which are very hygroscopic. The intermediate weighing of the boat and sample is carried out so that the final weighing may be made more rapidly, the approximate weight being already known.

Combustion may be started in air and finished in oxygen, the usual procedure being the same as that for the combustion of organic compounds. The rate of burning should be slow, and there should be no sparking of the coal. It is necessary to heat the ash at  $800^{\circ}\text{C}$ . for at least 10 minutes to ensure complete decomposition of carbonates, but a lower temperature suffices for the burning of the organic matter. When all the coal has been burned, the apparatus is swept out for half an hour with air, the absorption tubes are disconnected and removed to the balance room, and the bubble tube is attached to the end of the combustion tube. The calcium chloride and Sofnolite tubes should be hung in the balance room for at least half an hour before being re-weighed. The ash remaining in the boat should be weighed and carefully examined to see whether any carbon has escaped combustion.

*General Notes on Manipulation.*—(i) The section of the tube containing the copper oxide must be heated to at least  $800^{\circ}\text{C}$ . (ii) Care must be taken to avoid over-heating the section of the combustion tube which contains the lead chromate, otherwise the combustion tube will be attacked and fail. The Author has found it convenient to use a separate hard-glass tube to contain the lead chromate and the silver spiral ; this tube is drawn out at one end and connected

## Determination of Carbon and Hydrogen

to the combustion tube by a rubber stopper, and is heated in a separate furnace. (iii) The calcium chloride used for the absorption of moisture should be dried at 180° to 200° C., saturated with carbon dioxide and subsequently freed from the excess of carbon dioxide by having air blown through it. The calcium chloride should be enclosed in a stoppered U-tube having a bulb blown on the side arm through which the gases enter; the limb on the entry side of the U-tube should have about an inch of coarse calcium chloride at the top, the remainder of the filling should be fine. (iv) The tubes of the absorption train should be carefully chosen so that their side-tubes are of the same diameter; the ends of the side-tubes should be ground flat to enable glass-to-glass joints to be made, and connection should be by good seamless thin-walled rubber tubing. (v) The air used for sweeping out the apparatus should not be derived from a compressor; air from a compressor almost invariably contains traces of hydrocarbon vapours. (vi) The oxygen must not be prepared by the electrolytic process, since electrolytic oxygen may contain up to 0.5 per cent. of hydrogen.

*Note.*—R. Belcher and C. E. Spooner ("Fuel," 1941, 20, p. 130) describe a rapid method for the simultaneous determination of carbon, hydrogen, sulphur, and chlorine in coal. 0.5 gm. sample is burned in a rapid stream of oxygen at 1350° C., the time required for the combustion being only 10 min. The sulphur (as oxides) and the chlorine are absorbed in a spiral of silver gauze, and the water and carbon dioxide in anhydrous (magnesium perchlorate) and soda-asbestos respectively. The sulphur (as silver sulphate) and chlorine (as silver chloride) are determined by extracting the silver spiral successively with hot water and ammonium hydroxide.

### Accuracy of the Results

*Carbon.*—If the coal contains appreciable quantities of carbonates, the carbon dioxide collected during the combustion will include not only that derived from the organic carbon in the coal, but also that from the decomposition of the carbonates. 1 per cent. of calcium carbonate in the coal would yield 0.44 per cent. of carbon dioxide, which is equivalent to 0.12 per cent. of carbon, so that the carbon as determined by combustion would be 0.12 per cent. high. It would be necessary, therefore, to apply a correction based on a direct determination of carbon dioxide by a method such as that described on pages 65–67.

*Hydrogen.*—The water collected during the combustion includes, in addition to that formed by the combustion of organic hydrogen, combined water from hydrated minerals in the coal. On the average, this amounts to about 0.08 per cent. for every 1 per cent. of shale, and shale is generally the preponderant mineral impurity in coal.



## Fuel Testing

The error in the hydrogen will be only one-ninth of this, which is comparatively trifling. There is no satisfactory method for determining the combined water in the mineral matter of rocks which contain much organic matter. But while the error in the hydrogen arising from this cause is but small, the error in the oxygen (which is obtained by difference) will be eight times the error in the hydrogen unless the content of mineral matter in the coal is calculated by some formula such as that of King, Maries and Crossley (p. 114), and this should always be done.

### DETERMINATION OF NITROGEN

Nitrogen is determined by a modification of the Kjeldahl process in which the coal is boiled with concentrated sulphuric acid, whereby the carbon is oxidised to  $\text{CO}_2$  and the nitrogen is converted quantitatively to ammonia which is retained as sulphate, and is determined in the usual way by distillation into standard acid.

About 1 gm. of finely powdered coal is weighed and transferred into a hard glass Kjeldahl flask and 9 gm. of anhydrous potassium sulphate and 0.2 gm. of selenium are added. The solid mixture is shaken and 30 ml. of concentrated sulphuric acid are poured down the neck of the flask so as to wash any solid particles to the bottom of the flask. A light glass bulb is used to close the neck of the flask, which is supported in an inclined position, and the liquid is heated at or slightly above a "critical rate," which is determined as follows: a number of experiments are made, each at a different rate of heating, as the rate of heating is increased, the time taken for charred matter to disappear slowly decreases until a "critical" rate of heating is passed, at which the "clearing" time suddenly drops. Unless the critical rate of heating is exceeded, the standard "after-boiling" period of 2 hours will be insufficient completely to convert the nitrogen in the coal into ammonia. Electric heating is convenient, since the optimum rate of heating may be permanently fixed merely by adjusting a resistance; when gas-heating is used, the pressure of gas to each burner should be adjusted by reference to an adjacent manometer, so that a previously determined pressure may be employed.

After heating has been continued for 20 minutes, the flask is shaken to rinse down splashed material. The mixture is usually free from charred matter in from 30 to 35 minutes; heating is then continued for 2 hours, after which the source of heat is removed. When the liquid has cooled, the stopper is washed and the rinsings are collected in a 1-litre round-bottomed flask containing about 200 ml. of distilled water. The contents of the Kjeldahl flask are transferred into the litre flask, and the interior is rinsed with distilled

## Determination of Total Sulphur

water. The litre flask is fitted with a tap or thistle funnel and an efficient splash-head which is connected, through a condenser, if desired, to a bulbed tube dipping into 20 ml. N/10 sulphuric acid. 130 ml. of a solution containing 400 gm. of sodium hydroxide per litre are added through the funnel, and about 150 to 200 ml. are distilled over. The excess of sulphuric acid is titrated with N/10 sodium hydroxide, using methyl orange or methyl red as indicator.

A blank determination is carried out substituting pure cane sugar for the coal in order to supply a correction for nitrogen compounds in the reagents used.

*Note.*—H. E. Crossley ("Fuel," 1941, 20, p. 144) has shown that the initial rate of heating should be such that the "clearing time is less than 35 minutes, or the results will be low. The addition of 0.5 gm. vanadic oxide to the mixture enables the total time of heating to be reduced to one hour, the period of "after-boil" thus being reduced from 2 hours to 25 minutes.

### DETERMINATION OF TOTAL SULPHUR

#### " Eschka " Process

One gm. of the finely powdered coal is accurately weighed into a porcelain or platinum crucible and intimately mixed with 3 gm. of Eschka mixture, and the contents of the crucible are then covered with a further gram of the Eschka mixture. The mixture consists of 2 parts by weight of pure *light* calcined magnesium oxide and 1 part by weight of anhydrous sodium carbonate. Alternatively, pure calcium oxide may be substituted for the calcined magnesium oxide. The latter is frequently contaminated with traces of sulphate, whereas sulphur-free calcium oxide is readily obtainable, and is cheaper than the "AR" grade of magnesium oxide. On the other hand, light magnesium oxide has the advantage of lower density, the result being that coal mixed with Eschka mixture made from magnesium oxide is distributed throughout a more bulky mass than when the calcium oxide mixture is employed; this is of advantage in the subsequent incineration.

The uncovered crucible is heated gently at first (1 or 2 hours) to ensure the slow expulsion of the volatile matter, and the temperature is then gradually raised to a red heat, heating being continued until all black particles have disappeared from the contents of the crucible. To ensure complete incineration of the coal, the mass in the crucible should be stirred from time to time during (but not before) the final heating with a stout wire of platinum or nickel.

Heating is best carried out in an electrically heated muffle furnace, since, if gas is employed, there is always a risk of contamination of the contents of the crucible with traces of sulphur compounds.

## Fuel Testing

If an electric muffle is not available, a spirit lamp or a gas-heated muffle, in which the products of combustion of the gas do not come into contact with the crucible, may be used.

When incineration is complete, as shown by the absence of black particles in the mixture in the crucible, the charge, after cooling, is transferred to a beaker, the crucible is washed out with hot water and the liquid is diluted to about 150 ml. 10 ml. of bromine water are added, and the beaker is stood on a water-bath for half an hour. By this treatment, the incompletely oxidised sulphur compounds of sodium and magnesium are oxidised to sulphates. An excess of hydrochloric acid, sufficient to dissolve the solid matter, is added, the solution is boiled to expel bromine and filtered. The filtrate is boiled and nearly neutralised with ammonium hydroxide (using two or three drops of methyl orange as indicator), after which, without interrupting boiling, 2 ml. of concentrated hydrochloric acid are added. 10 ml. of a 10 per cent. solution of barium chloride are run in in a fine stream into the boiling solution and boiling is continued for 15 minutes. The beaker is then allowed to stand for at least 4 hours, after which the liquid is filtered through a fine paper (Whatman No. 40 is suitable) or through a Gooch crucible, the precipitate being washed with hot water until the washings show not more than a trace of opalescence with silver nitrate solution. The filter paper and precipitate are dried and ignited, the residue being treated with a drop of sulphuric acid and re-ignited, after which it is weighed. The weight of sulphur is given by multiplying the weight of barium sulphate by 0.1374.

A blank test, using the same quantity of Eschka mixture as is used in the actual determination, and conducted under exactly the same conditions, should be made to supply a correction for sulphur in the reagents or absorbed during the test, and the weight of barium sulphate found in the blank is deducted from the weight found in the determination proper. If incineration is carried out in an electric muffle, it is sufficient to make a blank test on each fresh batch of Eschka mixture and bromine water, but where gas heating is employed, frequent blank tests should be made, since contamination from the products of combustion of the gas may vary from day to day. N. Simpkin and E. H. Jones<sup>3</sup> have shown that, contrary to many assertions which have been made, the Eschka method is reliable when applied to coals which contain considerably over 2 per cent. of sulphur. ~

## Bomb Method

One important advantage of this method is that the determination of total sulphur in a coal may be combined with the determination

## Distribution of Sulphur

of its calorific value, therefore time, apparatus and materials are saved.

After the determination of the calorific value, the bomb is allowed to stand for at least 30 minutes to let acid mist settle ; the compressed gases are then released, 4 minutes being allowed for this. If the coal contains over 3 per cent. of sulphur, the determination should be repeated, the gases being passed through an oxidising solution such as sodium hypobromite or pure hydrogen peroxide. When the gases have been released, the bomb is opened, the lid, exit valve, interior of the bomb and the crucible are washed thoroughly with distilled water, the washings being collected in a beaker and added to the solution which was used to scrub the gases. A small amount of sulphur (generally not exceeding 0.1 per cent. on the coal) will be lost in the discarded ash ; this may, if necessary, be recovered by fusing the ash with sodium carbonate, extracting the melt with dilute hydrochloric acid, and adding the extract to the washings from the bomb.

The combined washings are treated with 2 ml. of bromine water, followed by 2 ml. of concentrated hydrochloric acid. The temperature is raised to boiling, the liquid is filtered and the residue on the filter is washed with boiling water. The filtrate is diluted to about 250 ml. and the procedure followed for the Eschka process is then repeated.

Certain precautions are necessary if the method is to give accurate results : (i) the bomb should be of a pattern in which there is no lead washer, since there is great difficulty in removing lead sulphate therefrom, (ii) the lining of the bomb must not be liable to attack by dilute mineral acids, and (iii) there should be two separate valves for filling and exhausting the bomb.

### DISTRIBUTION OF SULPHUR

Sulphur in coal occurs in three forms : (i) as sulphates, generally as gypsum ( $\text{CaSO}_4 \cdot 2\text{H}_2\text{O}$ ), and sometimes also as ferrous sulphate ( $\text{FeSO}_4 \cdot 7\text{H}_2\text{O}$ ) ; (ii) as sulphide of iron (pyrite or marcasite,  $\text{FeS}_2$ ), and (iii) combined in the organic matter. Sulphate sulphur is generally low, less than 0.1 per cent. being a common figure ; sulphide sulphur may vary from 0.2 to 3 per cent. or over, while organic sulphur, which is invariably present, may vary within wide limits.

The percentage of sulphide sulphur is generally capable of being reduced by cleaning ; sulphate sulphur is often more difficult to remove, since gypsum has a tendency to adhere firmly to the coal, and, by reason of its flakey habit, the difference in specific gravity between the gypsum and the coal (on which property most cleaning processes largely rely) is discounted. The organic sulphur, since

## Fuel Testing

it is an essential part of the coal substance, is not reducible by cleaning.

It is important to be able to discriminate between the forms in which sulphur occurs in coal, since an opinion may then be formed of the possibility of reducing the sulphur by cleaning; moreover, the sulphur which is returned in the ultimate analysis should show organic and inorganic sulphur separately.

Pyritic and sulphate sulphur are determined directly, organic sulphur is usually taken to be the difference between the total and the inorganic sulphur. The methods generally used to determine inorganic sulphur are modifications of those described by A. R. Powell and S. W. Parr.<sup>4</sup>

*Determination of Sulphate and Pyritic Sulphur.*—The coal used should be ground to pass a 120 B.S. sieve (= 100-mesh I.M.M.).

*Sulphate Sulphur.*—5 gm. of coal are shaken with 200 ml. of dilute hydrochloric acid (made by diluting 3 ml. concentrated acid to 100 ml. with distilled water) in a stoppered 500 ml. conical flask, until the coal is wetted. A further 100 ml. of the dilute acid is then added to wash the coal from the sides of the flask, and digestion is carried out for 40 hours at about 60° C. During this period, the flask is shaken periodically to disperse the coal in the liquid. At the end of the 40 hours the liquid is filtered through a Gooch crucible, the asbestos mat of which has previously been washed with dilute hydrochloric and dilute nitric acid. The residue from the flask is transferred to the crucible and washed two or three times with small quantities of distilled water. The contents of the crucible may be retained for subsequent determination of the pyritic sulphur, or a separate sample may be used for this estimation. The filtrate is treated with 2 ml. of bromine water, the liquid is heated to boiling, and a slight excess of ammonium hydroxide is cautiously added. After a few minutes the precipitate of ferric hydroxide is removed by filtering through a coarse filter paper. It is unnecessary to remove any precipitate which adheres to the glass, but the vessel should be set aside for subsequent redissolving of the precipitate. The precipitate is washed three times with small quantities of distilled water containing traces of ammonium hydroxide and ammonium chloride.

The filtrate is slightly acidified with hydrochloric acid, and the sulphur is determined as barium sulphate in the usual way.

If the pyritic sulphur is to be determined in a separate sample of the coal (and only if so), the ferric hydroxide and the filter paper are transferred to the vessel used for its original precipitation, a little concentrated hydrochloric acid is added and the liquid is warmed and stirred vigorously to macerate the paper. The solution is diluted to about 100 ml. with distilled water and then filtered through paper in a Gooch crucible. After having been thoroughly

## Distribution of Sulphur

washed with hot distilled water, the residue is transferred to a platinum crucible, where it is ignited; the iron is then extracted from the ash by boiling with concentrated hydrochloric acid, and the solution is added to the main solution. The total iron may then be determined by titration with titanous sulphate, using a thiocyanate indicator, by the method of W. F. Hillebrand and G. E. F. Lundell.<sup>5</sup>

*Pyritic Sulphur.*—A fresh sample of 5 gm. of the coal, or the residue and asbestos from the determination of sulphate sulphur is covered with 300 ml. of dilute nitric acid (1 volume of acid of S.G. 1.42 with 3 volumes of water) in a stoppered 500 ml. conical flask. 10 ml. of bromine water are added and the mixture is allowed to stand, with occasional shaking, for 24 hours. The liquid is then filtered through paper or an asbestos filter and the residue is washed with a little cold distilled water. The filtrate is heated almost to boiling and the iron is precipitated as hydroxide by addition of a slight excess of ammonium hydroxide solution. The liquid is stirred, boiled for 1 or 2 minutes, allowed to stand until the precipitate has settled and then filtered through a coarse paper. The precipitate is washed three times with cold distilled water containing traces of ammonium hydroxide and ammonium chloride, the filtrate being discarded. A hole is made through the apex of the filter, and as much as possible of the precipitate is washed into the beaker used for the precipitation. The minimum amount of water from a very fine jet should be used. The paper is rinsed with 5 ml. of dilute hydrochloric acid (50 per cent. by volume), previously heated to boiling. The paper is then rinsed with just sufficient water completely to remove the yellow stain, and ignited in a platinum crucible and the ash is added to the precipitate in the beaker. 10 ml. of concentrated hydrochloric acid are added, digestion is carried out at the boiling-point until all ferric hydroxide has dissolved. The liquid is diluted with 200 ml. of boiling water and the precipitation is repeated. The precipitate is redissolved as before, the liquid is diluted with cold water, and again precipitated. The reprecipitation is to free the solution from nitrates. The iron is then determined by titration with titanous sulphate. If the extraction with nitric acid was carried out on the residue after extracting with hydrochloric acid, the iron thus determined is the "pyritic iron." If a fresh sample has been used, the "pyritic" iron is the difference between the amounts of iron in the two extracts.

The percentage of pyritic sulphur in the coal is  $1.15 \times$  the percentage of "pyritic" iron.

Treatment of coal with dilute nitric acid is liable to cause oxidation and solution of part of the organic sulphur with some coals, hence it is inadvisable to determine the sulphur in the extract or in

## Fuel Testing

the residue, since the results would have no absolute significance. The organic sulphur is the difference between the total and the inorganic sulphur.

Blank tests should be occasionally carried out, particularly with regard to the determination of sulphate sulphur and to the possibility of contamination by sulphur compounds from gases in that determination.

## Direct Determination of Pyritic Sulphur

The method consists in the reduction of the pyritic sulphur to hydrogen sulphide by nascent hydrogen, its precipitation as cadmium sulphide and subsequent titration by standard iodine solution. The procedure, which is a modification of that proposed by W. Mantel and W. Radmacher,<sup>6</sup> was worked out under the direction of the Author by G. A. Cave and has not hitherto been published. A suitable quantity of coal, ground to pass a 120-mesh B.S. sieve is mixed intimately with 15 gm. of zinc dust and introduced into a 1 litre round-bottomed flask provided with a rubber stopper through which passes (a) a tube connected with a cylinder of carbon dioxide, (b) a dropping funnel charged with 100 ml. of concentrated hydrochloric acid, and (c) a delivery tube leading to three wash-flasks, the first containing distilled water, the second and third a 3 per cent. ammoniacal solution of cadmium chloride. This solution is made by dissolving 6 gm. cadmium chloride in about 150 ml. distilled water and adding concentrated ammonium hydroxide until the precipitate at first formed just redissolves. The air is swept out of the apparatus by carbon dioxide and the hydrochloric acid is run into the flask drop by drop from the funnel, the heat of reaction being sufficient to keep the contents of the flask hot. When the reaction shows signs of slowing down, carbon dioxide is again passed through the apparatus and this is continued for 10 minutes after the reaction has ceased.

The contents of the cadmium chloride flasks are washed out into a large flask with N/100 ammonia, 25 ml. of N/10 iodine solution are added, followed immediately by sufficient hydrochloric acid to render the mixture acid. The excess iodine is titrated with N/10 sodium thiosulphate solution.

This method is useful not only for the determination of pyritic sulphur in materials such as coals and oil shales, but also for the complete removal of pyrite. If the sample has been previously treated for the removal of sulphate sulphur, the residue, after determination of pyritic sulphur, may be used for the direct determination of organic sulphur. In the examination of oil shales, A. L. Down<sup>7</sup> and the Author have found that it is necessary to isolate the

## Determination of Oxygen

“kerogen.” or organic matter before an accurate analysis can be made, and the removal of pyrite by the process described above forms an essential step.

### DETERMINATION OF OXYGEN

Unfortunately, there is no satisfactory method for the direct determination of oxygen in coal. Oxygen is arrived at by deducting from 100 the percentages of carbon, hydrogen, nitrogen, sulphur and mineral matter, and therefore bears all the errors and uncertainties of the other determinations. The figure for “oxygen” should therefore always be described as “oxygen *plus* errors” or “oxygen by difference.” While the errors are doubtless comparatively trifling with coals which contain but little mineral matter (yielding, say, up to 5 per cent. of ash), where the mineral content is high, the errors may be very large.

#### THE ANALYSIS OF OIL SHALES AND MATERIALS HIGH IN MINERAL MATTER

When it is necessary to determine the composition of the organic matter in materials such as oil shales which may yield up to 80 per cent. of ash, the methods used for coals cannot be applied without modification, on account of the (frequent) high content of carbonates of lime, magnesia and iron and the presence of unknown quantities of hydrated silicates of alumina in the form of clay. Before an accurate analysis of the kerogen (organic matter) can be made, the greater part of the inorganic matter must be removed; to effect this, the following method has been worked out by the Author and A. L. Down, and successfully employed in researches on oil shales and similar materials.

A suitable quantity of the finely ground (–90-mesh I.M.M.) is treated on a steam-bath for 2 hours with 5N hydrochloric acid to dissolve carbonates; if necessary, two treatments may be given. In this way, carbonates of lime, magnesia and iron, together with sulphates, are removed and the residue contains only silicate minerals and pyrite. The residue is transferred to a platinum basin, made into a paste with 5N hydrochloric acid, hydrofluoric acid is added and the liquid is evaporated to dryness, the treatment being repeated two or three times or until all silica has been removed as silicon tetrafluoride. The residue in the dish is heated with 5N hydrochloric acid and thoroughly washed with hot distilled water.

To remove pyrite, it is dangerous to employ dilute nitric acid, since the kerogen of some shales is appreciably nitrated, even by acid of S.G. 1.12, therefore the residue from the treatment with hydrofluoric acid is dried, carefully mixed with zinc dust, and the mixture is treated with 5N hydrochloric acid, whereby the sulphur in the pyrite is reduced to hydrogen sulphide, the iron passing into solution as chloride. The kerogen is then filtered off, washed with hot distilled water and dried. By this process it has been found possible to reduce the ash to as low as 0.8 per cent., a quantity which is insufficient to cause the introduction of errors in calculating the composition of the kerogen to the dry ash-free basis. Having prepared a sample of the almost completely de-ashed kerogen, the ordinary methods of coal analysis may be applied.



## Fuel Testing

### ULTIMATE ANALYSIS OF COKE

#### DETERMINATION OF CARBON AND HYDROGEN

The determination is carried out as for coal, except that the slow preliminary heating, which is necessary while the volatile matter is being distilled from coal, is unnecessary; the boat may be heated from the beginning at the full temperature of the furnace.

#### DETERMINATION OF SULPHUR

As for coal. Pyritic sulphur is not determined.

#### DETERMINATION OF NITROGEN

As for coal, save that the preliminary "boil" for the complete removal of black particles may require several hours. The "after-boiling" period of 2 hours necessary as for coal. With some high temperature cokes, the liquid may fail to clear completely, a few black particles remaining unattacked; these particles may be ignored, they appear to be graphitic and are free from nitrogen.

#### BIBLIOGRAPHY

- <sup>1</sup> Fuel Research Board, Survey Paper No. 44, 1940.
- <sup>2</sup> British Standards Institution, Specification No. 678, 1936.
- <sup>3</sup> N. Simpkin and E. H. Jones, *Journ. Inst. Fuel*, 1929, **12**, p. 168.
- <sup>4</sup> A. R. Powell and S. W. Parr, Univ. Illinois Bull. No. 34, 1919; A. R. Powell, U.S. Bureau of Mines, Tech. Paper No. 254, 1921.
- <sup>5</sup> W. F. Hillebrand and G. E. F. Lundell, "Applied Inorganic Analysis," 1929.
- <sup>6</sup> W. Mantell and W. Radmacher, *Glückauf*, 1938, **74**, pp. 375-6 and pp. 983-93.
- <sup>7</sup> A. L. Down, *Journ. Inst. Petr.*, 1939, **25**, pp. 230-7.

## CHAPTER IV

### MISCELLANEOUS DETERMINATIONS

#### “FIXED” AND “VOLATILE” SULPHUR<sup>1</sup>

“FIXED” sulphur is defined as that which remains in the ash when the coal is burned, “volatile” sulphur is the difference between the “fixed” and total sulphur. The percentage of “fixed” sulphur in any coal will depend on the conditions under which it is burned, but if the method of incineration described on page 34 is adhered to, consistent results should be obtained.

For each determination of “fixed” sulphur, sufficient coal is incinerated under standard conditions to yield from 0.2 to 0.3 gm. of ash. The ash is transferred to a beaker, 90 ml. of distilled water, 5 ml. of bromine water and 10 ml. of concentrated hydrochloric acid are added, and the mixture is digested at the boiling-point for 1 hour, the beaker being covered with a clock-glass. The liquid is then filtered and the residue is thoroughly washed with hot distilled water. The residue is reserved. The filtrate is neutralised with ammonium hydroxide, an excess of 2 ml. of hydrochloric acid is added and the sulphur is determined by precipitation with barium sulphate in the usual way.

Should the weight of sulphur, calculated from the barium sulphate, exceed 0.01 gm., the reserved insoluble residue may contain a little sulphur. In these circumstances the residue is ignited and the ash fused with sodium carbonate. The melt is dissolved in hydrochloric acid, and after adjusting the acidity and dilution as above, any sulphur is determined as before. Any sulphur found in the residue is added to that previously determined to give the corrected value for the “fixed” sulphur.

A blank determination should be made when the fusion is necessary, to correct for sulphur in the sodium carbonate, or sulphur picked up from the gas during the fusion.

#### ARSENIC

All coals and cokes contain small quantities of arsenic, usually of the order of a few parts of arsenious oxide per million of coal, occasionally, however, the arsenic may rise to as high as several hundred

## Fuel Testing

parts per million, or even to two thousand. Although generally present in mere traces, the amount of arsenic present in coal sometimes assumes considerable importance, for example, where the products of combustion come into contact with foodstuffs, into which dangerous concentrations may be carried, or, as has happened on at least two occasions, when there is a suspicion of attempted destruction of arsenical preparations by burning them in cases of murder. It is usually assumed that arsenic occurs in coal in the form of arsenical pyrite, although it has been suggested that part of the arsenic may be in organic combination. Experiments made by N. W. Duck,<sup>3</sup> under the direction of the Author, showed that two coals when separated into fractions by float-and-sink analyses contained more and more arsenic as the specific gravity of the fraction increased; this supports the view that the arsenic is present as arsenical pyrite.

When coal is burned, part of the arsenic is volatilised and part (Duck found 69 per cent.) is retained in the ash. The relative proportions between the "volatile" and "fixed" arsenic will vary with the conditions in which the coal is used, so that little significance can be attached to attempts to determine "fixed" and "volatile" arsenic separately.

## British Standard Method <sup>3</sup>

The method is a modification of that proposed by Gutzeit, and requires the following materials:

*Lead Acetate Paper.*—Filter paper is soaked in a 1 per cent. solution of lead acetate, dried and cut into strips  $7 \times 5$  cm.

*Test Discs.*—Made from Ford's Gold Medal 38-lb. white blotting demy. Strips of the blotting paper are soaked in a 1 per cent. solution of pure mercuric chloride and dried over anhydrous calcium chloride, in a dark place. From these strips, discs 14 to 15 mm. in diameter are cut and preserved in the dark over anhydrous calcium chloride.

*Sulphuric Acid.*—Concentrated (S.G. 1.8), dilute (S.G. 1.2 and S.G. 1.01).

*Iron Alum Solution.*—10 gm. of sodium chloride are added to 100 ml. of sulphuric acid (S.G. 1.2), 84 gm. of ferric ammonium alum are dissolved in distilled water containing 10 ml. of the above solution and made up to 1 litre.

*Stannous Chloride Solution.*—80 gm. arsenic-free stannous chloride are dissolved in 100 ml. of distilled water containing 5 ml. of concentrated hydrochloric acid.

*Standard Test Discs.*—1 gm. of pure arsenious oxide is dissolved in 25 ml. of sodium hydroxide solution (S.G. 1.2), the liquid is

## Arsenic

neutralised with dilute sulphuric acid (S.G. 1·2) and the solution is made up to 1 litre with dilute sulphuric acid of S.G. 1·01. 10 ml. of this solution are made up to 1 litre with dilute sulphuric acid (S.G. 1·01), giving solution 1, containing 0·1 mgm.  $\text{As}_2\text{O}_3$  per ml.

100 ml. of solution 1 are made up to 1 litre, giving solution 2, containing 0·001 mgm.  $\text{As}_2\text{O}_3$  per ml.

An appropriate amount of solution B is run into the reaction bottle "A" (Fig. 10), then 3·4 ml. of concentrated sulphuric acid,

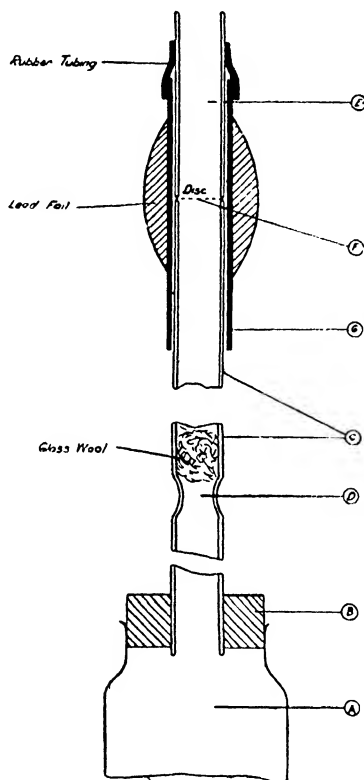

FIG. 10.—Apparatus for Determination of Arsenic.  
(Extracted, by permission, from B.S. No. 420, 1931.)

and from this point the Gutzeit procedure, as described on page 64, is followed. A series of test discs is thus prepared.

*Note.*—The standard test discs must be prepared by the analyst who is carrying out the determination. They must be stored, each in a small thin-walled tube containing a little phosphorus pentoxide or anhydrous calcium chloride, stoppered with a well-fitting rubber stopper and sealed with paraffin wax.

*Apparatus.*—It consists of a 60 c.c. wide-mouthed bottle "A," into which fits a rubber stopper "B" carrying a glass tube "C,"

## Fuel Testing

of 10 mm. internal diameter, 14-15 mm. external diameter and 190 mm. length. At a distance of 70 mm. from the lower end there is a constriction "D," the external diameter of the tube at this point being 10 mm. Above the constriction of the tube is placed a pad of glass wool moistened with a 1 per cent. solution of lead acetate and below a roll of the lead acetate paper. The glass tube "E" is of the same diameter as "C." The disc of test paper "F" is held between the tubes "C" and "E," the ends of which are ground flat in order to preserve close contact with the edge of the disc. The upper tube "E" is supported in the correct position by a closely fitting outer glass tube "G," fastened to tube "E," by means of rubber tubing; and to ensure that all the gases from the reaction bottle "A" pass through the disc of test paper "F," the outer tube "G" is weighted by 150 gm. of lead foil.

*Procedure.*—From 1 to 2 gm. air-dried, finely ground coal are weighed into a flat-bottomed silica dish and intimately mixed with 1 gm. of finely powdered heavy magnesium oxide. The mixture is moistened with 2 to 3 ml. of arsenic-free lime-water and is heated in a muffle furnace, gently at first and then the temperature is raised gradually to 650°-700° C. This temperature is maintained until all black particles have completely disappeared and the coal is completely oxidised.

The calcined residue is transferred to the reaction bottle "A," neutralised with dilute sulphuric acid (S.G. 1.2), using two or three drops of methyl orange as indicator and 3 to 4 ml. of concentrated sulphuric acid are then added. 2 ml. of the iron alum solution are reduced by adding the stannous chloride solution, and the mixture is added to the contents of the reaction bottle, the total volume in the bottle being made up to 50 ml. with distilled water. 10 gm. of arsenic-free zinc shot ( $\frac{1}{8}$  to  $\frac{1}{4}$ -mesh) are added and the stopper "B" is rapidly inserted, care being taken to avoid displacement of the test disc "F." The reaction is allowed to proceed for an hour, the reaction bottle being supported in a water-bath at from 40° to 50° C. The disc of test paper is removed and preserved in the dark in a small, thin-walled tube over calcium chloride, and closed with a well-fitting rubber stopper. The amount of arsenic is determined by comparing the disc with standard discs prepared in the same manner.

*Notes on Manipulation.*—The two surfaces of the blotting paper specified show different textures. It is important, in placing the test discs in the apparatus, that the same surface should always be presented to the stream of gas from the apparatus.

Duck<sup>3</sup> found that it was advisable to modify the above procedure slightly as follows:

The pleated lead acetate paper was omitted and a longer plug of glass wool, saturated with lead acetate solution, was substituted for it; the gas

## Carbon Dioxide

leaving the reaction bottle maintained a layer of solution above the plug and a good scrubbing effect was obtained, whereby  $H_2S$  was effectively removed. About 3 inches above this was a dry plug which prevented spray from reaching the test disc.

A 200 ml. bottle was employed instead of the 60 ml. bottle suggested, since frothing in the smaller bottle caused trouble.

For the determination of very small quantities of arsenic, an apparatus was made in which the diameter of the tubing was half that in the usual apparatus, which resulted in the stains being four times as intense. This apparatus was used to cover the range of samples containing from 0 to 15 micrograms of arsenic trioxide: the larger apparatus was employed for higher ranges.

The standard stains were made up afresh every month; the test paper was made by soaking Ford's 38-lb. white blotting demy in a 1 per cent. solution of mercuric chloride in acetone. This solution was easier to make up, and gave a more even distribution of the salt than the aqueous solution.

The hydrogen was liberated by means of a tin-zinc couple, prepared by standing zinc hot in a solution of stannous chloride in dilute hydrochloric acid; the couple was removed, washed with distilled water, and allowed to dry before use.

Blank tests were carried out on all the materials used.

### Fuel Research Board Method <sup>1</sup>

In this method the coal is incinerated in contact with a mixture of 10 parts magnesium oxide, 5 parts sodium carbonate, and 3 parts potassium nitrate. Instead of comparing the intensity of the stain produced on a disc of mercuric chloride paper, the *length* of the stain produced on a standard strip of mercuric bromide paper is compared with the length of stain produced from a known weight of arsenic.

### CARBON DIOXIDE

When coal contains appreciable amounts of carbonates, it has already been seen that the carbon determined by combustion is liable to be appreciably in error, furthermore, the ash as determined by incineration will be low to an extent which equals the percentage of carbon dioxide evolved from the carbonates during incineration. It is therefore necessary to determine the percentage of carbon dioxide present as carbonates in order to provide the necessary corrections to enable the true organic carbon to be calculated and to allow for the error in the ash to be corrected.

A convenient apparatus for the gravimetric determination of carbon dioxide is illustrated in Fig. 11.

The flask A, of 500 ml. capacity, is provided with a double-surface condenser B, a dropping funnel C, and an air-inlet tube D, which reaches to the bottom of the flask. It is convenient if the connections of B, C and D to the flask are by means of standard

## Fuel Testing

ground-glass joints, but if desired, a wide-necked flask with a rubber stopper bored with three holes to carry B, C and D may be used. The tower F contains soda-lime which serves to remove  $\text{CO}_2$  from the air which is drawn through the apparatus during a determination, and the small bubbler E, containing sulphuric acid, enables the rate of flow of air to be observed and controlled. The gases issuing from the flask are passed through a double-surface condenser B, to condense as much as possible of the water vapour, then through a drying system, which consists of one or more U-tubes G containing calcium chloride which has been saturated with carbon dioxide, next through two weighed U-tubes H and H', containing soda-lime impregnated with an indicator, in which the carbon dioxide from

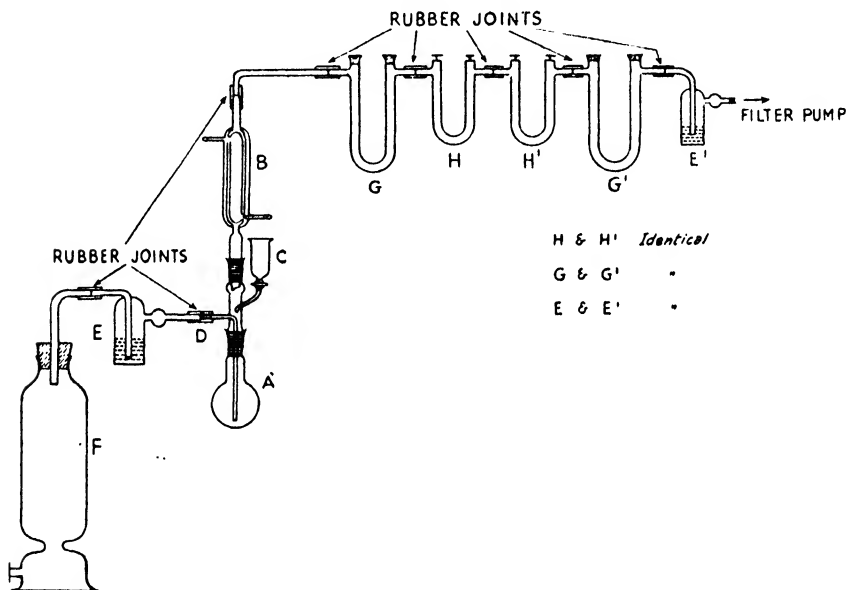

Fig. 11.—Apparatus for Determination of Carbon Dioxide in Coal.

the coal may be weighed ; to prevent loss of moisture from these tubes, there should be half an inch of calcium chloride at the top of the packing in each limb. Tube G' contains calcium chloride and the bubbler E' sulphuric acid, thus enabling the rate of flow of air from the apparatus to be observed and controlled.

To carry out a determination, a suitable weight (from 3 to 5 gm.) of finely ground coal is weighed into the flask A and 100 ml. of cold, well-boiled distilled water are added ; the air is displaced by  $\text{CO}_2$ -free air, the flask is closed with a stopper and well shaken to wet the coal. The apparatus is then erected as shown in Fig. 11 and air is drawn through it via the tower F to fill the system with  $\text{CO}_2$ -free air. The tubes H and H' are removed to the balance room and weighed after

## Phosphorus

standing for about half an hour ; while this is being done, the open end of tube G should be closed. The tubes H and H' are re-connected and 25 ml. of phosphoric acid (S.G. 1.3) are run into the flask from the dropping-funnel C. The contents of A are gently heated to boiling-point either over a gauze or in a glycerine-bath, boiling is continued for half to three-quarters of an hour, the rate of boiling being adjusted so that all the liquid is refluxed by the condenser. Tubes H and H' are then removed, allowed to stand for about half an hour in the balance room and re-weighed. A few coals contain easily decomposable sulphides which, when boiled with phosphoric acid, evolve hydrogen sulphide ; with these coals it is necessary to introduce, between tubes G and H, a U-tube containing silver sulphate or anhydrous copper sulphate packed with layers of glass wool to trap  $H_2S$ .

### PHOSPHORUS

A certain small amount of phosphorus is invariably present in coal, presumably as calcium phosphate in the mineral matter ; while, generally, the content of phosphorus is of little or no importance, if the coal is to be used for the manufacture of metallurgical coke which is subsequently to be employed for the smelting of hematite ores, it is necessary to determine the phosphorus, since for this purpose, low phosphorus in the coke is essential. As far as is known, all the phosphorus in coal remains in the ash left on incineration, hence the determination is carried out on the ash.

The following method is based on the results of a comprehensive investigation by the Northern Coke Research Committee,<sup>4</sup> and is described in references 1 and 2. It is essential that the conditions specified should be rigidly adhered to, since all the detailed precautions are important.

About 2 gm. of ash are prepared by incinerating the coal to constant weight at  $775^\circ \pm 25^\circ C.$ , the percentage of ash obtained being noted. The ash is ground to pass a 240-mesh B.S. sieve (= 200-mesh I.M.M.), re-ignited at  $775^\circ \pm 25^\circ C.$  to expel any moisture and  $CO_2$  which may have been absorbed during grinding, and transferred to an airtight container. The weight of ash to be taken depends on the phosphorus content (as determined, if necessary, by a trial analysis) and should be in accordance with the table on page 68.

The ash is weighed into a platinum crucible of about 30 ml. capacity, 10 ml. of concentrated nitric acid are slowly added and 5 ml. of hydrofluoric acid (containing about 550 gm. of HF per litre, and free from phosphorus). The covered crucible is heated on a hot-plate (care being taken to avoid loss by spitting) and the liquid is evaporated to dryness in about 45 minutes. The process is repeated,



## Fuel Testing

after which the last traces of fluorides are removed by adding a further 5 ml. of concentrated nitric acid, which is evaporated to dryness. By this preliminary treatment, silica, which would interfere with the subsequent precipitation of phosphorus by ammonium molybdate, is removed.

Approximate Percentage of Phosphorus in Ash.	Weight of Ash to be Taken. Gm.
Greater than 1 . . . .	0.1
1.0 to 0.75 . . . .	0.2
0.75 to 0.5 . . . .	0.25
0.5 to 0.25 . . . .	0.4
0.25 to 0.1 . . . .	0.5
Less than 0.1 . . . .	1.0

The final residue is treated with 15 ml. of dilute nitric acid (S.G. 1.2), and the liquid is evaporated to about 7 ml. This solution is transferred to a 250 ml. beaker, the contents of the crucible being rinsed into the beaker until the volume of the solution is about 80 ml. The beaker is then covered with a clock-glass and the liquid is boiled for 15 minutes, after which the solution is filtered through a No. 3 Whatman paper, 9 cm. in diameter, into a 500 ml. conical flask, the residue is washed into the filter and washing is continued until 10 ml. of the filtrate give an alkaline reaction with phenolphthalein and one drop of N/10 NaOH. The washing usually increases the volume to the filtrate to about 250 ml. The filtrate is evaporated to about 50 ml. and concentrated ammonium hydroxide solution (S.G. 0.880) is added drop by drop until a slight permanent precipitate appears. Concentrated nitric acid is added drop by drop till the precipitate is just dissolved, and then 4 ml. concentrated nitric acid. The mouth of the flask is closed by a cork carrying a thermometer whose bulb is immersed in the liquid without touching the sides or bottom of the flask, a small hole in the cork giving access to the air in the laboratory.

The solution is heated to 75° C., the flask is removed from the source of heat, the cork and thermometer are taken away and a thin continuous stream of 30 ml. ammonium molybdate solution (see p. 69), previously heated to 55° C., is run in. The molybdate solution must be run in slowly in a steady stream and the solutions mixed vigorously during the process. After the molybdate solution has been added, the cork and thermometer are replaced, the flask is shaken for 2 minutes and the contents are then maintained at 50° C. for 30 minutes. After this period, the flask is allowed to cool and to stand for not less than 3 hours, but not longer than overnight. Any material departure from the conditions specified for the pre-

## Phosphorus

precipitation may vitiate the determination by the precipitation, for example, of molybdic acid.

The liquid is filtered through a No. 32 Whatman paper, 11 cm. in diameter, or through a Gooch crucible; the precipitate is transferred to the filter and washed with a neutral 0.1 per cent. solution of potassium nitrate, washing being continued until 10 ml. of the washings give a strongly alkaline reaction with one drop of N/10 NaOH and one drop of neutral phenolphthalein. Since the precipitate is slightly soluble in the washing liquid, and since this solubility is increased by oxidation, the quantity of washing liquid must be kept to a minimum and the precipitate must be kept wet.

The precipitate and paper (or asbestos pad) are transferred to a 500 ml. flask, provided with a stopper carrying a tube of soda-lime, 15 ml. of N/10 sodium hydroxide solution (prepared as described below) are added, the stopper and soda-lime tube are fitted, the contents of the flask are warmed to 35° to 40° C., the flask is agitated to disintegrate the paper and to complete the solution of the precipitate. The liquid is cooled, neutral phenolphthalein is added and the excess NaOH is titrated with N/10 nitric acid solution.

The weight of phosphorus in grams = 0.000135 (ml. of N/10 sodium hydroxide *minus* ml. of N/10 nitric acid). The percentage of phosphorus is calculated in the ash and then in the coal from the data previously obtained.

*Preparation of the Ammonium Molybdate Solution.*—100 gm. pure molybdic acid (containing not less than 85 per cent. of MoO<sub>3</sub>) are dissolved in a mixture of cold distilled water and 80 ml. of concentrated ammonium hydroxide. The solution is mixed by shaking, and then it is poured slowly into a solution of 400 ml. of concentrated nitric acid (S.G. 1.42) in 600 ml. of distilled water contained in a flask, the flask being rotated during the addition to cause rapid mixing. 50 mgm. of microcosmic salt (NaNH<sub>4</sub>HPO<sub>4</sub> · 4H<sub>2</sub>O), dissolved in a small quantity of water, are added, the mixture is gently heated, with frequent shaking, to 65° C., allowed to stand overnight, after which the solution is decanted into a dark brown stoppered stock-bottle. *This reagent must not be kept for more than three months.*

*Preparation of the N/10 Sodium Hydroxide.*—The solution is prepared in the usual manner and standardised against N/10 nitric acid *under the conditions in which it is to be used when determining phosphorus*, i.e. with careful exclusion of carbon dioxide and in the presence of disintegrated filter paper. Titration is to be carried out in a 500 ml. flask provided with a stopper carrying a soda-lime tube, so that the only communication between the air in the flask and the air in the laboratory is via the soda-lime tube. 15 ml. of the sodium hydroxide solution are introduced into the flask together with a Whatman filter paper or an asbestos pad (according to which is to

## Fuel Testing

be used in filtering the phosphomolybdate precipitates) which has been washed with the 0.1 per cent. solution of potassium nitrate. The stopper and soda-lime tube are placed in position and the liquid is warmed to 35° to 40° C., the flask being shaken from time to time to disintegrate the filter. The liquid is then cooled and titrated with N/10 nitric acid (using phenolphthalein as indicator), the factor being calculated.

## CHLORINE

Nearly all coals contain a certain amount of chlorine, usually from 0.05 to 0.20 per cent., but sometimes as much as 1.0 per cent. It is not known exactly how the chlorine is combined, part at any rate is present as chlorides of the alkali metals, and part may be in organic combination. Where coal is to be carbonised, the presence of chlorides is very detrimental, since at high temperatures they are volatilised and cause rapid corrosion of the walls of gas-retorts and coke-ovens. It must be remembered that chlorides may be introduced into coals during wet cleaning if the water used contains considerable proportions of chlorides. It is therefore necessary to keep a check on the washery water and also on the chlorine content of the coal.

The Fuel Research Board<sup>1</sup> state that there is no satisfactory method of determining the water-soluble chlorine in coal, since extraction of powdered coal with hot water is generally incomplete unless the coal is ground extremely fine, and they therefore suggest a method for the determination of the total chlorine as follows :

5 gm. of the finely powdered coal are accurately weighed and thoroughly mixed with approximately 6 gm. of anhydrous sodium carbonate in a porcelain crucible. The mixture is covered evenly with a further 3 gm. of sodium carbonate and the crucible is placed in a cold muffle furnace. The temperature is raised to  $475^{\circ} \pm 25^{\circ}$  C. in a period of 1 or 2 hours and maintained at that temperature until incineration is complete, which usually requires about 20 hours. The contents of the crucible should not be stirred during the first 12 hours, and the furnace should be adequately ventilated.

After the incineration the crucible is allowed to cool, the contents are transferred to a 400 ml. beaker and the crucible is washed with the *minimum quantity of chlorine-free* distilled water from a fine jet. 40 ml. of water are added to the contents of the beaker, which is then covered with a clock-glass, and 30 ml. of concentrated nitric acid (S.G. 1.42) are poured in through the lip of the beaker. The solution is heated to the boiling-point, but boiling is not allowed to continue, after which it is allowed to cool and stood in a place free from contamination by chlorine until the supernatant liquid is clear. The solution is then filtered through a Gooch crucible containing

## Soluble Mineral Salts

filter paper, using suction. The beaker is rinsed with two portions of 5 ml. of distilled water, each rinsing being poured through the filter, after which the residue is washed with two further portions of 5 ml. of distilled water. The filtrate is transferred to a 350 ml. conical flask, the filter-flask being rinsed with two portions of 5 ml. of distilled water and drained thoroughly after each rinsing. The clear liquid is heated, without being boiled, and an excess (25 ml. is usually sufficient) of N/20 silver nitrate solution is added. The flask, covered with a watch-glass, is allowed to stand in a dark place, free from contamination by chlorine, until the precipitate has settled. The liquid is then filtered through paper in a Gooch crucible, using the same procedure as before for rinsing and washing. To the filtrate in the suction-flask, 2 ml. of a solution of iron alum, to act as an indicator, are added and the mixture is titrated with N/20 ammonium or potassium thiocyanate solution, the end-point being shown first by a change from white to cream, subsequent drops changing the colour through orange to blood-red. The first permanent change from white is the end-point. 1 ml. of N/20 silver nitrate corresponds to 0.001773 gm. of chlorine.

*Note.*—The iron alum solution should be prepared by adding sufficient nitric acid to a cold, saturated solution of ferric ammonium alum to remove the brown colour, and the colour of the indicator should be no deeper coloured than pale straw.

If the coal is known to contain 0.05 per cent. (or less) of chlorine, N/50 solutions may be substituted for the N/20. If the chlorine content is known to be relatively high (say, 0.7 per cent. or over), 3 gm. of coal should be taken instead of 5 gm.

Several determinations may be made simultaneously, a blank determination being carried out with each batch.

## SOLUBLE MINERAL SALTS

Comparative results may be obtained by the following method : 25 gm. of finely powdered coal (— 240-mesh B.S. sieve or — 200 I.M.M.) are weighed into a 400 ml. conical flask ; 250 ml. chlorine-free distilled water are added and the flask is heated for several hours on a water-bath. During this period, the flask should be shaken from time to time to make sure that all the coal is thoroughly wetted. The liquid is filtered off and the coal is washed until the washings are free from chlorides ; the filtrate and washings are then made up to 500 ml.

100 ml. of the solution are transferred to a tared, hard glass basin, evaporated to dryness and dried to constant weight at 130° C., giving the total soluble salts. To determine the chlorides, a drop

## Fuel Testing

of water is added to the residue in the basin, together with one drop of neutral potassium chromate solution to act as indicator, and the chlorides are titrated with N/50 silver nitrate solution. The result is calculated as percentage of sodium chloride on the coal.

Sulphates are determined gravimetrically on another 100 ml. portion and calculated as sodium sulphate.

### BIBLIOGRAPHY

<sup>1</sup> Fuel Research Board, Survey Paper No. 44, 1940.

<sup>2</sup> British Standard Specifications, No. 1016, 1942.

<sup>3</sup> N. W. Duck, "The Occurrence of Arsenic in Coal," M.Sc. Thesis, London University, 1938.

<sup>4</sup> A. Edwards, H. Marson and H. V. A. Briscoe, *Journ. Soc. Chem. Ind.*, 1932, 51, p. 179T.

## CHAPTER V

### THE CALORIFIC VALUE OF SOLID AND LIQUID FUELS

SINCE the purchase of fuel is, in effect, the purchase of energy in convenient and compact form, the mere statement of *quantity* of material conveys little information, unless at the same time an indication of the energy content per unit of weight is also given. An accurate and rapid method of determining the potential energy in coal (or in any other fuel) is therefore required, and it is the purpose of this chapter to consider the principles and methods of determining calorific value.

The calorific value of solid or liquid fuel is expressed as the number of heat units liberated by complete combustion of unit weight of the fuel. In the British system of units, calorific values are expressed as British thermal units (B.Th.U.s.) per pound, a B.Th.U. being the quantity of heat required to raise one pound of water through  $1^{\circ}$  F. in the neighbourhood of  $60^{\circ}$  F. The corresponding metric unit, known as the large calorie or kilogram centigrade unit (K.C.U.), is the amount of heat required to raise one kilogram of water through  $1^{\circ}$  C. in the neighbourhood of  $15^{\circ}$  C.  $1$  B.Th.U. =  $0.252$  K.C.U., and  $1$  K.C.U. =  $3.9683$  B.Th.U.s.

The methods used to determine the calorific value of fuel have very different degrees of accuracy, and may be classified as direct or indirect.

#### DIRECT METHODS

*A.*—Combustion of a known weight of coal, either compressed into a pellet, or as a powder, in an atmosphere of oxygen at a pressure of at least 25 atmospheres.

*B.*—A known weight of coal is burnt, either compressed into a pellet or in powdered form, in a current of oxygen at atmospheric pressure.

*C.*—A known weight of the finely powdered coal is burnt, intimately mixed with an easily decomposed solid high in oxygen content, such as potassium nitrate and potassium chlorate or sodium peroxide.

The essentials of a direct method are (*a*) that combustion must be complete, and (*b*) that means must be adopted to determine

## Fuel Testing

accurately the heat liberated by carrying out the combustion under such conditions that all the heat is absorbed in a known weight of water, the rise in temperature of which is a measure of the heat absorbed.

To fulfil the first condition it is found that the coal (compressed into a pellet) must be burnt in oxygen at a pressure of at least 25 atmospheres. It is advisable that the coal should be in pellet form (some solid fuels such as coke, lignite and anthracite will not form a pellet under pressure), as if burnt as a powder there is risk that some of the sample may be expelled unburnt from the zone of combustion. Unless the oxygen is at a pressure of at least 25 atmospheres there is serious risk of incomplete combustion, even though there be a large excess over and above that required for the complete combustion of the coal.

Experiments made by the Author illustrate this point. Two coals were tested in a bomb calorimeter of approximate capacity 250 ml., using various oxygen pressures, with the following results :

	Nakashima Coal.	Fu Chung Anthracite.
Volatile matter . . . . .	35.1	6.9
Fixed carbon . . . . .	44.9	82.8
Ash . . . . .	20.0	10.3
Gm. oxygen required per gm. coal .	2.3	2.7

Pressure in Bomb Atmospheres.	Approx. Gm. Oxygen in Bomb.	Apparent Calorific Values.	
		B.Th.U.s. per Lb.	
30	10.12	11,290	13,585
25	8.43	11,295	13,585
20	6.74	11,210	13,470
15	5.05	11,195	13,490
10	3.46	11,120	12,475
5	1.77	9,920	Failed to burn

The figures show that in a 250 c.c. bomb, unless the oxygen pressure is 25 atmospheres, there can be no assurance that combustion is complete. Hence it is decidedly doubtful whether combustion of coal in a calorimeter using oxygen at atmospheric pressure will be complete, even though the amount of oxygen passed may be far in excess of that actually required.

The practice of supplying oxygen from an easily decomposed solid is unsatisfactory on several grounds. Firstly, combustion is almost certain to be incomplete ; secondly, unknown errors are introduced by dissociation of the oxygen-supplier ; and, thirdly, there is

## Indirect Methods

a serious possibility of interaction of the mineral constituents of the coal with it.

The writer made tests in a well-known make of calorimeter in which the coal was burnt mixed with sodium peroxide. Abnormalities were met with which it was suggested might be due to liberation of heat arising from interaction between the ash in the coal and the sodium peroxide. Several determinations of the calorific value of starch were therefore made in the calorimeter, the mean result being 8000 B.Th.U.s. per pound. Additions of ash from two coals were made to samples of starch, and the calorific value was determined on the mixtures, with the following results :

	Coal A. Added ash (per cent.)	12	27	31
	Change in apparent calorific value, B.Th.U.s. per lb. . . . .	-200	+150	+200
	Coal B. Added ash (per cent.)	6.8	21.5	
	Change in apparent calorific value, B.Th.U.s. per lb. . . . .	+150	+750	

Even though the effect observed with coal B may have been abnormal and rare, the results show that it is dangerous to rely on figures obtained from an apparatus of this type ; there may be no indication that a particular coal is showing an abnormality, which may in fact be present.

The second condition requires that combustion shall take place in a closed vessel, completely surrounded by water and insulated to reduce to a minimum loss or gain of heat. This requirement is usually more or less satisfactorily fulfilled by commercial forms of apparatus, and in any case, if the lagging is found to be defective, it can be corrected, so that serious failure to fulfil this condition can be overcome without radical change in the apparatus.

### INDIRECT METHODS

These are attempts to correlate the heating value of a coal with either the ultimate or the proximate composition. In the present imperfect state of our knowledge of the nature of the coal substance and the constitution of the various bodies which go to make up the different classes of coal, it is not surprising that the accuracy of indirect methods of estimating calorific value is low. A résumé of several formulæ and a discussion of their limitations is given below.

The following formula is due to Dulong :

$$Q = \frac{1}{100} \left[ 8080C + 34,460 \left( H - \frac{1}{8}O \right) + 2250S \right]$$



## Fuel Testing

where  $Q$  is the calorific value in K.C.Us. per kilo, and  $C$ ,  $H$ ,  $O$ , and  $S$  are respectively the percentages of carbon, hydrogen, oxygen and sulphur in the coal, the assumption being made that the contribution of each element to the calorific value of the coal is that which it would make were it in the free state, subject to the qualification that the oxygen in the coal is assumed to be combined as water with its quota of hydrogen, which hydrogen is therefore considered to make no contribution to the heating value of the coal. To give a true value, the heat of formation of the coal should be deducted from the sum of the heats of combustion of the elements, but our information is not sufficiently complete, and as a first approximation the above assumption is made.

The error of the formula is not likely to exceed 2 per cent., except in dealing with cannels and coals high in oxygen (more than 7.5 per cent.), a condition met with in "oxidised" bituminous coals, and in brown coals and lignites generally, or where the carbon in the coal exceeds 90 per cent. The serious difficulty which arises in such cases, however, is that the error of the formula as compared with the high-pressure oxygen bomb is erratic, and is not correlated in any simple way with the oxygen content of the coal. This is illustrated by two coals examined by the Author, the first a Malayan black lignite containing 17.05 per cent. oxygen, in which case the calculated calorific value was 2.0 per cent. below the bomb result, while in the case of a Japanese coal of 9.6 per cent. oxygen, the formula gave a result 5.6 per cent. low.

Mahler showed that the heat of formation of fuels increases with the oxygen content, and on experimental grounds he suggested a formula,

$$Q = \frac{1}{100}[8140C + 34,500H - 3000(O + N)],$$

where  $N$  is the percentage of nitrogen.

Application of this method of calculation to the coals cited above gave a result just over 1 per cent. high for the black lignite, and 4 per cent. low in the case of the Japanese coal.

It is almost impossible to generalise as to the likely errors involved in using formulæ such as those above quoted, when the oxygen content of the coal exceeds 7.5 per cent., and there is no doubt that this difficulty arises in part (particularly with high-ash coals) from the fact that the oxygen is arrived at by difference, and therefore bears all the errors of the other determinations.

More recently, E. S. Grumell and I. A. Davies<sup>1</sup> have suggested

$$Q = (3.635H + 235.9)\left\{C + H - \frac{(O - S)}{8}\right\}$$

## Indirect Methods

where  $C$ ,  $H$ ,  $O$  and  $S$  are the respective percentages of carbon, hydrogen, oxygen and sulphur in the coal. It is based on the statement by Berthier that the heat produced by a fuel is proportional to the volume of air required for its combustion. That is,  $Q = kV$ , where  $Q$  is the quantity of heat,  $V$  the volume of air required to burn the fuel, and  $k$  is an empirical constant, which was determined for 63 representative coals. The formula gives remarkably good results, and is applicable to coals of any rank. Applied to four immature coals, the following results were obtained :

Coal.	Carbon Per Cent.	Calorific Value. K.C.U.s. per Kilo.		
		Bomb.	Dulong.	Grumell and Davies.
Reefton lignite .	76.15	7310	7394	7335
Rawang ,, .	73.4	7085	6940	6980
Palana ,, .	72.15	6830	6990	6860
Nam Ma ,, .	67.45	6255	5955	6305

Grumell and Davies point out that the Dulong formula is remarkably accurate for carbon contents up to 86 per cent. ; above 86 per cent. the accuracy falls off, and when the carbon in the coal exceeds 90 per cent. the Dulong formula ceases to have any value.

White,<sup>2</sup> as a result of the study of over 300 coals representing practically all the coals in the United States, with ash varying between 2.38 and 29.38 per cent., and oxygen between 1.82 and 38.57 per cent., suggests a formula :

$$\text{B.Th.U.s. per pound} = 16,780 - \frac{17,230}{r + 0.98},$$

where 
$$r = \frac{\text{carbon}}{\text{oxygen} + \text{ash}}.$$

The errors varied from + 7.7 to - 8.1 per cent., with an average error of 121 B.Th.U.s. per pound.

White's formula in the shape given above is not applicable to British coals or to coals of the Far East. The results on four British coals whose analyses and calorific values are given by Taylor and Patterson,<sup>3</sup> varied from 95 B.Th.U.s. per pound low to 1860 B.Th.U.s. high, and on four Chinese and Japanese coals the errors varied between - 775 and + 210 B.Th.U.s. per pound. It is therefore apparent that the White formula cannot be used for coals outside the United States unless it has been suitably modified by reference to bomb tests on coals derived from the districts in which it is to be used.

## Fuel Testing

Gouthal <sup>4</sup> proposed a formula for calculating the calorific value of coal from the proximate analysis :

K.C.U.s. per kilo =  $82C + aV$ , where  $C$  is the per cent. fixed carbon,  $V$  the volatile percentage, and  $a$  is a variable factor depending on the volatile yield calculated to the dry ash-free coal ( $V^1$ ). The relation between  $a$  and  $V^1$  is as follows :

$V^1 = 1-4$	10	15	20	25	30	35	40
$a = 150$	145	117	109	103	98	95	80

Where the value of  $V^1$  exceeds 40, extrapolation must be resorted to, which results in there being great likelihood of error in dealing with high-volatile coals.

Taylor and Patterson (*loc. cit.*) examined the application of the Gouthal formula to British coals, studying 18 coals for which  $V^1$  varied from 5.0 to 47.8, and they found that in 15 cases the agreement with the bomb calorimeter was within 5 per cent. (plus or minus), in two the error was between 5 and 6 per cent., and in the remaining example (a Warwickshire coal of  $V^1$  47.8) the formula gave results 13.3 per cent. below the bomb. There was no very definite correlation between the volatile matter and the formula error except for the high-volatile Warwickshire coal.

Twenty-nine coals from the Far East were examined by the Author, 16 giving less than 41 per cent. of volatiles on the dry ash-less coal, and 13 with volatiles between 43 and 54 per cent. In 15 of the first set, the formula gave results above the bomb, 14 calculated results being less than 5 per cent. in error, one just over 6 per cent., and one 16.6 per cent. too high. When the formula was applied to the other 13 coals, using extrapolation from a curve to evaluate  $a$ , the calculated results were invariably low, the errors being from 3.9 to 14.9 per cent., the tendency being for the error to increase with the volatiles.

It appears from a study of these 13 examples, that for coals of the Far East, the values of  $a$  which should be taken when  $V^1$  exceeds 40 per cent. are, when

$V^1 =$	40-45	45-50	50-55
$a =$	79.5	78	75.5

If these values of  $a$  be applied to these 13 coals, the formula error is reduced, in one example only exceeding 5 per cent. (negative), and in the other twelve being either positive or negative and under 5 per cent.

Application of these amended values of  $a$  to the high-volatile coals quoted by Taylor and Patterson results in bringing the calculated calorific value of the Warwickshire coal to 0.8 per cent. below the bomb value, for a Yorkshire washed slack in reducing the positive

## Indirect Methods

error from 220 to 20 B.Th.U.s. per lb., in two examples in changing a negative error to a somewhat larger positive deviation less than 5 per cent., and in two others in raising positive errors of 2.3 and 5.7 per cent. to 5 and 6 per cent. respectively, which suggests that as a first approximation the proposed values are nearer the truth than those derived by extrapolation from a curve.

K. Nakamura <sup>5</sup> developed a modification of the Gouthal formula which is stated to be applicable only to coals which yield over 20 per cent. of volatiles,

$$Q = a \left\{ V - \frac{\text{ash}}{10} \right\} + 78C,$$

where "a" depends on the volatile percentage and on the caking quality of the coal as follows :

Class.	Caking Quality.	Natural Moisture. Per cent.
1	Non-caking	Above 15
2	"	Below 15
3	Caking. Slight contraction	—
4	" " swelling	—
5	" Strong "	—

TABLE XI

VALUES OF "a" IN NAKAMURA FORMULA.

V.	20-25	25-35	35-37.5	37.5-40	40-42.5	42.5-45	45-47.5	47.5-50
1	—	—	60	60	64	64	68	68
2	—	—	68	68	70	70	73	73
3	—	—	75	76	78	79	80	81
4	—	84	84	84	85	86	87	88
5	125-116	116-110	98	96	96	95	95	96

The formula has not been applied to non-caking coals yielding less than 35 per cent. of volatiles ( $V_1$ ) on the dry ash-free basis. Suitable coefficients could, however, be determined.

The deduction of  $\frac{\text{ash}}{10}$  from the volatiles is made to allow for the fact that part of the "volatiles" as determined is derived from the combined water and pyritic sulphur in the mineral matter and not from the coal substance. The Nakamura formula has one advantage over the Gouthal formula in that it does not assume that

## Fuel Testing

the contribution of the volatile matter to the calorific value of a coal is constant for a fixed yield of volatiles.

When applied to the four lignites referred to on page 77, the Nakamura formula gives high results compared with the bomb calorimeter :

	Reefton.	Bawang.	Palana.	Nam Ma.	
Formula .	6488	4905	5390	5490	} K.C.U.s per kilo, as delivered
Bomb .	6190	4820	4980	4740	

Although, therefore, the Nakamura formula may apply to Japanese coals—indeed, it was based on a study of 12,337 different samples, taken from different seams—the values of the factor “*a*” evidently require to be re-determined before the formula can be applied successfully to coals from other parts of the world.

In the opinion of the Author, the sole use of formulæ of the Gouthal type is to enable a rough idea of the calorific value to be obtained when the proximate analysis is known, but when no sample is available.

A formula such as that of Grumell and Davies, however, is valuable, since it enables the calorific value to be calculated from the ultimate analysis with some precision in the (unfortunately rather rare) cases where the ultimate composition of coal is known, and in addition it places in the hands of the analyst a valuable method of checking his results. For should there be a serious discrepancy between the calorific value as determined in a bomb calorimeter and as calculated, an error is suggested, either in the determination of the calorific value or in the analysis of the coal.

### THE HIGH-PRESSURE BOMB CALORIMETER

When all is said and done, there is one method only which can be regarded as really satisfactory for the *determination* of the calorific value of coal, and that is the use of a high-pressure oxygen bomb calorimeter, but the first cost (from £40 upwards) is such that the expenditure may not be considered justifiable. Other calorimetric apparatus may be purchased from about £2 upwards, but the writer is of the considered opinion that it is preferable to calculate approximate calorific values from either the proximate or ultimate analysis than to spend money on the cheaper forms of calorimeter. If uncertainty is to be tolerated, there is no advantage in paying extra for results of doubtful value when they may be arrived at without

## High-Pressure Bomb Calorimeter

such extra cost by calculation. A calorimeter of the flow type is open to less objection than the pattern in which a solid oxygen-supplier is employed, as in the former case the results can suffer only from negative errors, whereas, as has already been seen, if the oxygen is supplied from a solid material the errors may be in either direction.

A high-pressure bomb calorimetric outfit consists of a steel bomb in which the fuel is burned in oxygen at a pressure of 25 atmospheres, a copper calorimeter vessel in which the bomb stands during the determination, an outer water-jacketed enclosure, a stirrer working in the water in the calorimeter, a thermometer graduated in hundredths of a degree, together with the necessary accessories for compressing coal into a pellet, and filling the bomb with oxygen.

While there are numerous makes of bomb, one type only is illustrated; the principle in all cases is the same, and the differences are matters of detail only.

A bomb calorimeter and its accessories should comply with the following conditions:

(i) The interior of the bomb must be resistant to the action of the acids formed during combustion, since serious errors may be introduced by the heat liberated during solution of the bomb; cheap bombs which are sometimes lined with nickel may give results which are  $2\frac{1}{2}$  per cent. high owing to this cause alone.

(ii) The quantity of oxygen in the bomb when filled to the working pressure of 25 atmospheres should be not less than  $2\frac{1}{2}$  times that required for complete combustion of the fuel.

(iii) The apparatus when in use must be surrounded by a water-jacketed enclosure which should contain from 15 to 20 litres of water.

(iv) The stirring apparatus, which may consist of a reciprocating or a high-speed propeller stirrer, must be operated at a uniform rate, so that the graph of temperature *vs.* time is a straight line.

(v) The thermometer should be graduated to  $0.01^\circ \text{C.}$ , and must be read by means of a lens to  $0.002^\circ \text{C.}$  Every thermometer must be provided with a certificate issued by the National Physical Laboratory or other competent testing authority, the corrections being given to the nearest  $0.005^\circ \text{C.}$ , or to  $0.002^\circ \text{C.}$  if the reliability of the thermometer permits. Either fixed-zero or Beckman thermometers may be used. If a Beckman thermometer is used, if the test certificate does not show the changing value of the degree, due to the variable quantity of mercury in the bulb, determinations of the water equivalent of the calorimeter should be made at various temperatures, when the zero of the thermometer corresponds to (say)  $10^\circ$ ,  $15^\circ$ , and  $20^\circ \text{C.}$ , and the appropriate value of the water equivalent should be used when calorimetric determinations are made.

## Fuel Testing

(vi) The oxygen must be available at a pressure of not less than 25 atmospheres ; it must be free from combustible matter. Oxygen made by the electrolytic process may contain traces of hydrogen, and is therefore not suitable.

### The Griffin-Sutton Bomb

The body *A* of the bomb is a stainless steel tube, of special composition, machined from the solid metal. It is screwed internally for a short distance at both ends, where, in addition, small shoulders are formed.

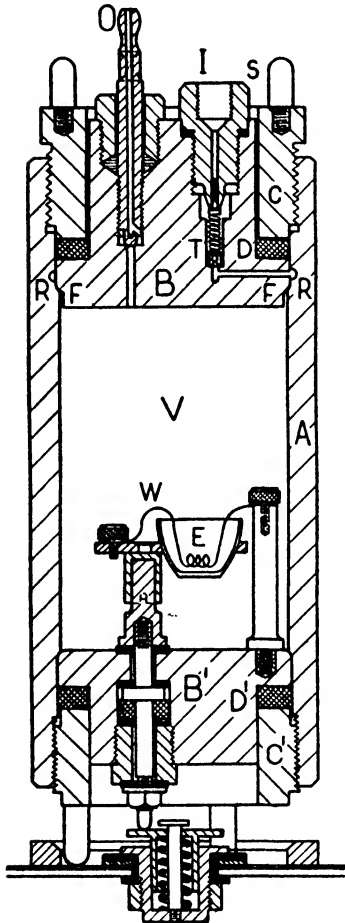

FIG. 12.—Griffin-Sutton Bomb.  
(By courtesy of Griffin & Tatlock, Ltd.)

The lower end is sealed by a rubber washer *D'*, inserted between a flanged cap *B'* and a screwed sleeve *C'*. The cap *B'* carries the ignition pillars and crucible support, which, being short, are rigid and strong. The pillar carrying the crucible support is insulated from the cap *B'* by a bush and by mica washers, and makes contact with a spring fixed to the bottom of the calorimeter, as shown.

The upper end is sealed in a similar manner by a washer, cap and sleeve, *D*, *B* and *C* respectively. The upper cap carries a screwed and rifled tube *O*, which is held in a gland and used for carrying off the gaseous products of combustion. This exit is sealed, while a determination is in progress, by screwing *O* down on to a seating in the cap by means of a small winged nut. The inlet valve *T* which is of the Schrader type, has proved to be thoroughly practicable in this new application, and is easily replaceable. Connection is made to the oxygen cylinder at the screwed inlet *I*, the inward path of the gas being through the valve *T*, and along a horizontal

duct into the annular groove *RR* turned in the wall of the bomb. From here the gas enters the interior *V* of the bomb, in an annular stream down the sides of the vessel via the space *FF*, thus avoiding any risk of disturbance of the charge in the crucible *E*. A small, rotatable clip is fitted to the upper cap to hold together con-

## High-Pressure Bomb Calorimeter

veniently the cap B and the sleeve C during the assembly of the bomb.

The caps B and B' are free to move axially outwards in the sleeves C and C', but by reason of the internal shoulders at R on the wall of the bomb they cannot move inwards. The pressure of the gas on their inner surfaces forces them outwards in opposite directions, compressing the washers D and D', which therefore expand laterally into contact with the inner wall of the body A, and thereby seal the interior so effectively that the sleeves C and C' cannot be removed until the pressure in the interior has been released.

*The calorimeter* consists of two cylindrical copper vessels of different diameters, connected by tubes near the top and bottom. In the smaller tube is fitted a stirrer having three triple-blade propellers carried on a stainless steel shaft which runs in three stainless steel ball-bearing journals. By these means it is assured that the temperature rise caused by the stirring is small and regular; it does not exceed 0.003° C. per minute and is included in the "radiation" correction. The bomb is placed in the larger tube and is located relative to the spring contact for the electrical ignition, by means of an annular ring on the bottom of the calorimeter. The calorimeter is fitted with two terminals for the electrical connections, one of which is insulated from it and connected to the insulated contact in the bottom, the other is in electrical contact with the wall of the calorimeter. The calorimeter is supported on three ebonite legs in a copper vessel which is surrounded by water contained in a large copper container, the outside of which should be brightly polished or well lagged with felt.

### Use of the High-Pressure Bomb \*

Sufficient finely ground (60-mesh I.M.M. sieve) air-dried coal to give a temperature rise of from 1.5° to 3° C. is compressed into a cylindrical pellet and weighed into the crucible of the calorimeter. A piece of fine platinum wire (0.003 in. thick) is tightly stretched across the pole pieces of the bomb, and one end of a piece of sewing cotton is tied round the wire; the crucible is placed in position and the loose end of the cotton is arranged so as to be in contact with the coal. As an alternative, a longer platinum wire may be used, and bent into a loop so as to touch the coal pellet.

10 gm. of distilled water are introduced into the bomb with the object of absorbing vapours of sulphuric and nitric acids formed during the combustion, and the lid of the bomb is screwed home and tightened.

\* This description of the method of using the bomb calorimeter is consistent with the relevant specifications of the British Standards Institution.<sup>6</sup>



## Fuel Testing

The bomb is connected with an oxygen cylinder and pressure gauge, the needle valve on the bomb \* is opened one complete turn, and oxygen is *slowly* admitted, the pressure being allowed to rise to 25 atmospheres ; the valve on the oxygen cylinder is closed, and then the needle valve on the bomb. After being disconnected from the filling apparatus, the bomb is stood in a bucket of water to test for tightness. It is then removed from the water, wiped, and the firing wires are attached to the terminals.

The calorimeter vessel is weighed, and sufficient water is weighed in completely to submerge the cover of the bomb. The calorimeter vessel is then stood in the outer jacket on the insulating feet provided, the bomb is introduced, the stirrer and lid of the calorimeter vessel are placed in position, and the thermometer is adjusted. The stirrer is then started and allowed to run for five minutes before observations are begun.

The temperature of the water is read to the nearest 0.002° C. at minute intervals for 5 minutes, the thermometer being tapped lightly at the level of the top of the mercury column during 10 seconds prior to each reading.

At the end of the fifth minute, the ends of the firing wires are momentarily connected to sufficient accumulators or dry cells to give from 8 to 12 volts in order to ignite the charge, and readings are continued at minute intervals. In the first 2 minutes after firing the temperature rises so rapidly that readings are possible only to the nearest 0.01°, but after that, the rate of rise decreases, and readings may be taken to the nearest 0.002°.

After the maximum temperature is reached, readings are continued at intervals of a minute until the rate of fall is uniform, when the stirrer is stopped and the bomb is removed from the calorimeter vessel. After it has been removed, half an hour should be allowed before the bomb is opened to allow complete settlement of the acid mist within.

The contents of the bomb are washed into a hard glass beaker, care being taken to remove any deposit of lead sulphate from the washer, † a measured excess (25 ml.) of N/10 sodium carbonate solution is added, the liquid is boiled down to about 10 ml. and filtered, and the precipitate of lead carbonate is washed. When cold, the filtrate is titrated with N/10 hydrochloric acid, using methyl orange as indicator. The liquid is acidified with hydrochloric acid, and the sulphur is determined as barium sulphate in the usual manner.

\* The needle-valve may be in the filling line (as with the Griffin-Sutton and Scholes bombs), but the same procedure should be followed.

† In some bombs, the joint between the lid and the body of the bomb is made gas-tight by means of a lead washer.

## High-Pressure Bomb Calorimeter

Assuming the weight of sulphur found to be  $S$  gm., the corresponding volume of N/10 sulphuric acid is

$$\frac{S}{0.0016} \text{ ml.}$$

If  $A$  ml. of N/10 hydrochloric acid were used in the back-titration, the total acidity due to nitric and sulphuric acids together is equivalent to  $(25 - A)$  c.c. N/10 acid, and the amount of nitric acid present is equivalent to

$$(25 - A) - \frac{S}{0.0016} \text{ ml. or, say, } B \text{ ml. N/10 nitric acid.}$$

### Correction for Acids Formed

The sulphur of the coal is converted by combustion in the bomb to sulphur trioxide, which is absorbed in the water forming sulphuric acid. During combustion of the coal in air the sulphur is burnt mainly to sulphur dioxide. The result is that in the bomb, for each 1 per cent. of sulphur in the coal, an extra 22.5 calories per gm. of coal are liberated, over and above that which would be realised in a furnace.

The nitrogen in the coal and part of that in the air in the bomb are converted into nitric acid, whereas in practice the nitrogen would pass off in the free state. To correct for the heat of formation of the nitric acid, for every c.c. of N/10 nitric acid, 1.43 calories must be deducted. The correction will therefore amount to 1.43  $B$  calories.

### Cooling Correction

The observed maximum temperature is lower than the true maximum by reason of the fact that the calorimeter vessel is subject to a small but definite loss of heat due to radiation.

The cooling correction applied is due to Regnault and Pfaundler, and has the form :

$$\text{Correction} = nv + \frac{v^1 - v}{t^1 - t} \{ \Sigma_1^{n-1}(t) + \frac{1}{2}(t_0 + t_n) - nt \} = nv + kP,$$

where  $n$  = number of minutes between the time of firing and the first reading after the temperature begins to fall from the maximum ;

$v$  = the rate of *fall* of temperature per minute during the period before firing ;

$v^1$  = the rate of fall of temperature per minute after the maximum temperature ;

$t$  and  $t^1$  = the average temperatures during the prefiring and final periods respectively ;

$\Sigma_1^{n-1}(t)$  = the sum of the readings during the period between firing and the start of cooling ;

## Fuel Testing

$\frac{1}{2}(t_0 + t_n)$  = mean of the temperature at the moment of firing and the first temperature after which the rate of change of temperature is constant ;

and  $k = \frac{v^1 - v}{t^1 - t}$  and is the "cooling constant" of the calorimeter.

For an instrument with a water equivalent of about 2500 gm., the value of  $k$  should not exceed 0.0025 if the heat insulation is adequate.

The cooling correction is to be added to the observed rise of temperature.

*Example of Use of Method.*  
*Weight of Coal, 1.1362 gm.*

*Water, 2600 gm.*  
*Total Water Equivalent of Apparatus, 3384 gm.*

Pre-firing Period.		Heating Period.		Cooling Period.	
Time.	Temp.	Time.	Temp.	Time.	Temp.
0	1.728	$t_1$ 6	3.47 <sup>o</sup>	$t_n$ 10	3.874
1	1.729	$t_2$ 7	3.87 <sup>o</sup>	11	3.872
2	1.731	$t_3$ 8	3.877	12	3.870
3	1.733	$t_4$ 9	3.877	13	3.868
4	1.735			14	3.866
$t_0$ 5	1.737			15	3.864

$$\begin{array}{lll}
 t = 1.732 & \Sigma_1^4 t = 15.094 & t^1 = 3.866 \\
 v = -0.0018 & \frac{1}{2}(t_0 + t_n) = 2.806 & v^1 = 0.002 \\
 & -nt = 8.66 \lambda & \\
 nv = -0.009 & P = 9.236 & k = 0.0018
 \end{array}$$

Cooling correction,  $nv + kP = -0.009 + 0.017 = 0.008$ .

N/10 sodium carbonate solution, 25 c.c.

N/10 hydrochloric acid, A 10.5 c.c.

Sulphur, S = 0.0085 gm. = 0.75 per cent.

N/10 nitric acid (25 - 10.5) -  $\frac{0.0085}{0.0016} = 9.2$  c.c. = B.

Correction for nitric acid,  $9.2 \times 1.43 = 13$  calories.

,, ,, sulphuric acid,  $0.75 \times 22.5 = 17$  calories.

Uncorrected temperature rise . . . . . (2.137)

Cooling correction , . . . . . 0.008

Corrected rise . . . . . 2.145

Heat liberated,  $2.145 \times 3384$  . . . . . 7259 calories

Correction for nitric acid . . . . . 13 ,,

Heat from 1.1362 gm. coal . . . . . 7246 ,,

Heat from 1 gm. coal . . . . . 6377 ,,

Correction for sulphuric acid . . . . . 17 ,,

Calorific value of coal . . . . . 6360 calories per gm.,  
 which is equivalent to  $6360 \times 1.8$  or 11,448 B.Th.U.s. per lb.

## High-Pressure Bomb Calorimeter

Iron firing wire is sometimes used, but is open to the objection that if an enamel-lined bomb is used, the lining is apt to suffer damage from splashing of molten droplets of oxide of iron. If iron wire is used, it must be weighed before the experiment, and the unburnt portions tied round the pole pieces must also be weighed, and an allowance of 1600 calories per gram of iron burned must be made in calculating the heat liberated by the coal.

Anthracite cannot be briquetted satisfactorily and is frequently incompletely burned if weighed into the crucible in the ordinary way. It is best weighed on a thin disc of mica or a layer of fine ignited sand or silica, placed in the bottom of the crucible; a known weight of benzoic acid, B.P. paraffin or other heavy hydrocarbon oil, say, 1 or 2 c.g.m., of known calorific value is then added. With a silica crucible the mica is unnecessary. Coals containing a high percentage of inorganic matter give a fused residue, which may enclose a considerable proportion of unburnt carbon. In such cases, combustion in a crucible, the bottom of which is covered with a thin layer of coarsely powdered quartz, is recommended. The quartz breaks up the fused ash into minute globules, thus minimising the proportion of unburnt carbon; it also facilitates the removal of the residue if it should appear desirable to determine the quantity of unburnt matter. To do this the residue in the crucible is reduced to a fine powder, mixed with lead chromate and burned as in an organic "combustion." The number of milligrams of carbon dioxide  $\times 2.2$ , + the number of milligrams of water (if any)  $\times 3.8$ , is equal to the heat of combustion of the residue in calories, assuming that the heat of formation is negligible.

### Correction for Cotton Thread

The correction for the cotton thread used for firing the charge is calculated from the weight of a known length, dried at 110° C., and the calorific value of cellulose, 4140 calories per gm.

### Water Equivalent of the Apparatus

Since not only is the water in the calorimeter vessel heated during the experiment, but also the metal of the bomb, the stirrer and the calorimeter vessel, together with part of the thermometer, it is necessary to know the amount of heat absorbed by them to cause their temperature to rise one degree. This is best determined by burning a known weight of pure benzoic acid (about 1.2 gm. is a convenient quantity) in the bomb under the experimental conditions described above. The benzoic acid must be carefully dried, either by keeping it in a desiccator over sulphuric acid for a prolonged period, or by heating it to not more than 5° C. above its

## Fuel Testing

melting-point (121° C.). The dry benzoic acid must be kept in a desiccator except when being weighed or compressed into briquettes, and must be burned either in briquette form or else as solidified after fusion. The standard value for the calorific value of benzoic acid is 6324 calories (15° C.) per gm., weighed in air.

Other suitable substances are :

Naphthalene . . . . .	9622 cal. per gm.
Salicylic acid . . . . .	5269 " "
Camphor . . . . .	9292 " "

The water equivalent as determined experimentally should be compared with that deduced from the sum of the products of the weights and the specific heats of the various parts of the apparatus, as in the following example :

Steel bomb, 6282 gm. × 0.01 . . . . .	628
Copper calorimeter, 1341 gm. × 0.095 . . . . .	127
Brass stirrer, 120 gm. × 0.095 . . . . .	11
Thermometer, say . . . . .	4
	<hr/>
Water equivalent of metal parts . . . . .	770

The water equivalent calculated as above should agree with that determined by experiment to within 15 or 20 gm.

The water equivalent of the apparatus referred to in the example was determined experimentally by burning a known weight of benzoic acid and of naphthalene in the bomb, and, as the result of several determinations, the value 784 was arrived at, which gives an agreement between the two methods of within 2 per cent. A greater difference would have pointed to some defect in the apparatus, such as an inaccurate thermometer.

## Accuracy of the Results

In the Fuel Research Board publication on "Methods of Analysis of Coal,"<sup>7</sup> the following remarks are made :

"Assuming that a thermometer is used which has been calibrated by systematic observations of separated thread lengths, a closer agreement than 30 B.Th.U.s. must, generally speaking, be regarded as accidental: if the reading error is 0.001° C., the possible error resulting from this alone is 18 B.Th.U.s. Since the calorific value of a coal expressed in British Thermal Units is usually between 10,000 and 15,000, the fifth figure has no meaning and should be rounded off to '0'; the fourth significant figure is uncertain to two or three units."

The calorific value of a fuel as determined in the bomb calorimeter is the constant-volume value, which is lower than the constant-

## High-Pressure Bomb Calorimeter

pressure figure to an extent depending on the hydrogen content of the fuel, but the difference is of the order of a tenth of 1 per cent., which is well within the limits of experimental error.

The constant-pressure value may be calculated from that at constant volume by the formula

$$Q_{cp} = Q_{cv} - (\Delta n)RT,$$

where  $Q_{cp}$  and  $Q_{cv}$  are the calorific values at constant pressure and constant volume respectively;  $\Delta n$  is the *increase* in the number of molecules in the gas after the reaction;  $R$  is the gas constant = 1.9885 (or 2.0 with sufficient accuracy), and  $T$  is the absolute temperature at which the reaction is carried out.

The units must, of course, be consistent; if metric units are employed, kilogram-molecules and degrees Centigrade + 273 must be used, and in British units, pound-molecules and degrees Fahrenheit + 460.

Consider a coal of ultimate composition

$$\text{C} = 82.0; \quad \text{H} = 4.90; \quad \text{N} = 1.3; \quad \text{S} = 1.0; \quad \text{O} = 5.8; \quad \text{ash} \\ 5.0 \text{ per cent.},$$

and gross calorific value 14,400 B.Th.U.s. per pound (bomb).

If this coal be burned and the products cooled to 60° F., there will be a reduction in the number of gaseous molecules due to the condensation of the water vapour produced.

1 lb. of coal contains  $\frac{4.90}{2 \times 100} = 0.0245$  lb.-molecules of hydrogen.

There is sufficient oxygen in 1 lb. of coal to combine with  $\frac{5.8}{100 \times 8}$  or 0.0073 lb. molecules of this hydrogen, leaving 0.0245 - 0.0073 or 0.0172 lb. molecules of hydrogen to be burned by gaseous oxygen, of which  $\frac{0.0172}{2}$  or 0.0086 lb. molecules will be required.

The diminution in gaseous molecules per pound of coal will therefore be 0.0086 =  $(\Delta n)$ .

$$\text{Thus } Q_{cp} = 14,400 + 0.0086 \times 2 \times 540 \\ = 14,400 + 9 = 14,409 \text{ B.Th.U.s. per lb.}$$

*Note.*—The calorific value as determined above is the gross calorific value expressed as 15° calories. The 15° calorie is 1 in 1,000 greater than the 20° calorie. Since specific heats vary with temperature, for an increase in temperature of 10° C. the total water equivalent of the apparatus decreases by about 1.5 gm. for a heavy bomb and by about 2.0 gm. for a light bomb. The total water equivalent of the apparatus is therefore unlikely to vary by more than 0.1 per cent. as a result of changes in temperature of the atmosphere, and no correction need be made.

## Fuel Testing

### DERIVATION OF THE REGNAULT-PFAUNDLER CORRECTION FOR RADIATION

Let  $q$  = the rate of loss of heat per unit difference of temperature between the calorimeter and the temperature of the air,  $T_a$  and  $t_1, t_2, t_3$  the temperatures of the calorimeter at the end of 1, 2, 3, etc., minutes after firing and  $t_n$  = the final temperature.

The mean temperatures, minute by minute, are then

$$\frac{t_0 + t_1}{2}, \frac{t_1 + t_2}{2}, \text{ etc. } \dots \frac{t_{n-1} + t_n}{2},$$

and the losses of heat (Newton's Law of Cooling)

$$= q \left\{ \frac{t_0 + t_1}{2} - T_a \right\}; q \left\{ \frac{t_1 + t_2}{2} - T_a \right\} \text{ etc., } \dots; q \left\{ \frac{t_{n-1} + t_n}{2} - T_a \right\}.$$

The total loss of heat in the principal period =  $nV$ , where  $n$  = the number of minutes in the period, and  $V$  = the average loss of heat per minute during the principal period.

Then, 
$$nV = q\{t_1 + t_2 + t_3 + \dots + t_{n-1}\} + \frac{1}{2}(t_0 + t_n) - nT_a$$

$$= q\{\mathcal{Z}(t)_1^{n-1} + \frac{1}{2}(t_0 + t_n) - nT_a\}.$$

The average temperatures of the calorimeter during the initial and final periods are  $T_0$  and  $T^1$  respectively, and the corresponding losses of heat  $V_0$  and  $V^1$ .

$$V_0 = q\{T_0 - T_a\} \quad \text{and} \quad V^1 = q\{T^1 - T_a\},$$

$$V^1 - V_0 = q\{T^1 - T_0 - T_a + T_a\} = q\{T^1 - T_0\},$$

whence, 
$$q = \frac{V^1 - V_0}{T^1 - T_0},$$
 also, 
$$T_a = T_0 - \frac{V_0}{q}.$$

Hence, 
$$V = \frac{V^1 - V_0}{T^1 - T_0} \left\{ \mathcal{Z}(t)_1^{n-1} + \frac{1}{2}(t_0 + t_n) - nT_a \right\}$$

$$= \frac{V^1 - V_0}{T^1 - T_0} \left\{ \mathcal{Z}(t)_1^{n-1} + \frac{1}{2}(t_0 + t_n) - nT_0 + \frac{nV_0(T^1 - T_0)}{V^1 - V_0} \right\}$$

$$= nV_0 + \frac{V^1 - V_0}{T^1 - T_0} \left\{ \mathcal{Z}(t)_1^{n-1} + \frac{1}{2}(t_0 + t_n) - nT_0 \right\}.$$

$V_0 = v_0 \times$  water equivalent, and  $V^1 = v^1 \times$  water equivalent, where  $v_0$  and  $v^1$  are the rates of change of temperature during the pre-firing and final periods respectively. Hence, the correction is arrived at by taking unit water equivalent, and

$$= nv_0 + \frac{v^1 - v_0}{T^1 - T_0} \left\{ \mathcal{Z}(t)_1^{n-1} + \frac{1}{2}(t_0 + t_n) - nT_0 \right\}.$$

## Gross and Nett Calorific Values

All commercial fuels contain hydrogen, and in the determination of calorific value, the water vapour formed by the combustion of the hydrogen is condensed and the water is cooled to the final temperature of the calorimeter. In practice, it is not feasible to cool the waste gases from a furnace sufficiently to condense the steam in them, thus neither the latent heat of condensation of the steam nor the sensible heat in the water are recoverable. It is therefore the practice to distinguish between the "gross" and "nett" calorific

## High-Pressure Bomb Calorimeter

values of fuels, the gross being the heat value as determined in a calorimeter and the nett, the gross or higher value less the latent heat of condensation of the water vapour *plus* (sometimes) also the sensible heat in the water between the assumed temperature of condensation (100° C.) and 15° C. The correction is thus 622 K.C.Us. per kilo or 1119.6 B.Th.Us. per pound of water. This correction is, however, unduly large; the most that can justifiably be allowed is the latent heat of condensation of steam at 15° C. (60° F.), namely, 586 K.C.Us. per kilo, or 1055 B.Th.Us. per pound of water, the weight of water being that produced by the combustion of the hydrogen in the fuel *plus* the moisture in the fuel.

### Calorific Value of Liquid Fuels

The procedure is the same as for solid fuels. Liquid fuels of high flash-point may be weighed directly into the crucible. Liquids of low flash-point, such as petrol, benzol, etc., should be weighed in small glass bulbs or gelatine capsules of known calorific value. Not only are they subject to loss of weight during handling, but there is a danger that the mixture of vapour and oxygen in the bomb may detonate when fired, and in consequence the lid of the bomb may be blown off, or the bomb itself may explode.

### BIBLIOGRAPHY

- <sup>1</sup> "Fuel," 1933, **12**, p. 199.
- <sup>2</sup> D. White, U.S. Geol. Surv. Bull. No. 29, 1909.
- <sup>3</sup> R. A. A. Taylor and W. S. Patterson, *Journ. Soc. Chem. Ind.*, 1929, **48**, 107T.
- <sup>4</sup> Gouthal, *Comptes Rendus*, 1902, **135**, p. 477.
- <sup>5</sup> K. Nakamura, *Journ. Fuel. Soc. of Japan*, 1929, **8**, p. 119.
- <sup>6</sup> British Standard Specifications Nos. 735, 1937, and 1016, 1942.
- <sup>7</sup> Fuel Research Board, Survey Paper No. 7, 1927.
- <sup>8</sup> "Dictionary of Applied Physics," **1**. Article, "Fuel Calorimetry," by W. J. A. Butterfield.



## APPENDIX TO CHAPTERS I TO V

### REPRODUCIBILITY OF ANALYTICAL RESULTS

The following Tables, reproduced by permission of the Controller of H.M. Stationery Office, are taken from Survey Paper No. 44 of the Fuel Research Board, and illustrate the degree of reproducibility of the results of the analysis of a single sample of coal which was sent to twelve laboratories during 1936. It is pointed out that the figures may need modification for coals differing appreciably in composition from the check-sample.

TABLE XII

#### ANALYSIS OF CHECK SAMPLE. RANGE OF RESULTS

Determination.	Average Result.	Reported Results.		Extreme Difference between Laboratories.
		Minimum.	Maximum.	
Moisture . . .	0.58	0.5	0.74	0.24
Volatiles . . .	24.15	23.12	25.2	2.08
Ash . . . . .	5.44	5.28	5.58	0.30
Fixed carbon . .	69.83	68.7	70.69	1.99
Carbon . . . . .	84.73	84.52	84.89	0.37
Hydrogen . . . .	4.62	4.50	4.80	0.30
Nitrogen . . . .	1.45	1.38	1.53	0.15
Sulphur (volatile)	0.67	0.60	0.72	0.12
Oxygen (by difference) . . .	3.06	2.75	3.39	0.64
Total sulphur . .	0.80	0.72	0.85	0.13
Carbon dioxide . .	0.54	0.43	0.66	0.23
Calorific value, B.Th.U.s. per lb.				
Air-dried . . . .	14,765	14,700	14,830	130
Dry ash-free . . .	15,720	15,650	15,790	140
Calculated (Dulong) . .	—	15,770	15,970	200

TABLE XIII

## DIVERGENCE BETWEEN DUPLICATE ANALYSES

	Maximum Permissible Difference between Duplicates. Odds 10 to 1.
<i>Proximate analysis</i> (air-dried basis)	
Moisture . . . . .	0·16
Volatiles . . . . .	0·26
Ash . . . . .	0·12
Fixed carbon . . . . .	0·31
<i>Ultimate analysis</i> (dry ash-free basis)	
Carbon . . . . .	0·20
Hydrogen . . . . .	0·15
Nitrogen . . . . .	0·07
Total sulphur . . . . .	0·05
Oxygen (by difference) . . . . .	0·54
<i>Calorific value</i> (dry ash-free basis) . . . . .	50 B.Th.U.s.

*Note.*—When reporting, results should be given as follows :

- (a) Proximate analysis, ultimate analysis and total sulphur to one decimal place. If the sulphur is less than 1 per cent., two places should be given.
- (b) Carbonisation assays. Results should be rounded off to the nearest 0·05 per cent.
- (c) Calorific values should be given to the nearest 10 B.Th.U.s. per pound or 5 K.C.U.s. per kilo.
- (d) Forms of sulphur, carbon dioxide, and chlorine should be reported to two decimal places.
- (e) Phosphorus should be reported as a percentage of the coal to three decimal places. Where, however, the amount exceeds 0·1 per cent., the third figure has little or no significance.

## CHAPTER VI

### CARBONISATION ASSAYS OF COAL

WHILE the proximate analysis of a coal gives a general idea of its behaviour when carbonised, particularly the total yields of volatile matter and coke, no information is afforded as to the nature and rate of evolution of the volatile matter at different temperatures, nor as to the effect of rate and time of heating on the quality of the coke.

To determine in some detail the nature and yields of the various products which may be expected when coal is carbonised, various assays have been described from time to time, and procedure has been standardised so as to enable the small-scale results to be correlated with those obtained in works practice. Standard methods have been devised and described in detail by the Fuel Research Board.

It is important in carrying out a carbonisation assay that the procedure should be standardised, otherwise the results will not be comparable with those of other workers. Any departure from the standard method should be clearly indicated in the report.

#### THE LOW TEMPERATURE CARBONISATION ASSAY OF COAL

The method and apparatus are recommended for the laboratory examination of coals by their carbonisation at temperatures about 600° C. The results throw light on the general properties of a coal and permit its behaviour on carbonisation on a large scale at the same temperature to be predicted. Thus :

(i) The yields of coke, gas, tar, liquor and ammonia are readily and accurately measured and large-scale yields may be predicted from them as follows :

*Coke.*—The yield and the volatile matter remaining are approximately the same as in large-scale practice.

*Gas.*—The yield from the assay is generally slightly greater than that obtained on a large scale owing to the necessity for limiting the time of carbonisation in industrial working.

*Tar.*—The yield on a large scale is generally about 60 per cent. of that in the assay.

*Ammonia.*—The yields are generally nearly alike.

## Carbonisation Assays of Coal

(ii).The appearance of the cylinder of coke is similar to that obtained by carbonisation on the large scale, provided that powdered coal is used and that the working temperature is the same.

(iii) The temperature at which rapid decomposition of the coal begins may be recorded either by observing the appearance of oil vapours or by noting the start of steady evolution of gas.

(iv) The yield of oils is sufficient to allow of their specific gravity to be determined with reasonable accuracy.

(v) The gas may be analysed and its specific gravity and calorific value determined. The composition of the gas is not materially different from that obtained on the large scale, the chief difference being the smaller percentage of unsaturated hydrocarbons in the gas from the assay.

### Description of Apparatus

The assembled apparatus is represented diagrammatically in Fig. 13, and scale-drawings of certain parts are shown in Fig. 14.

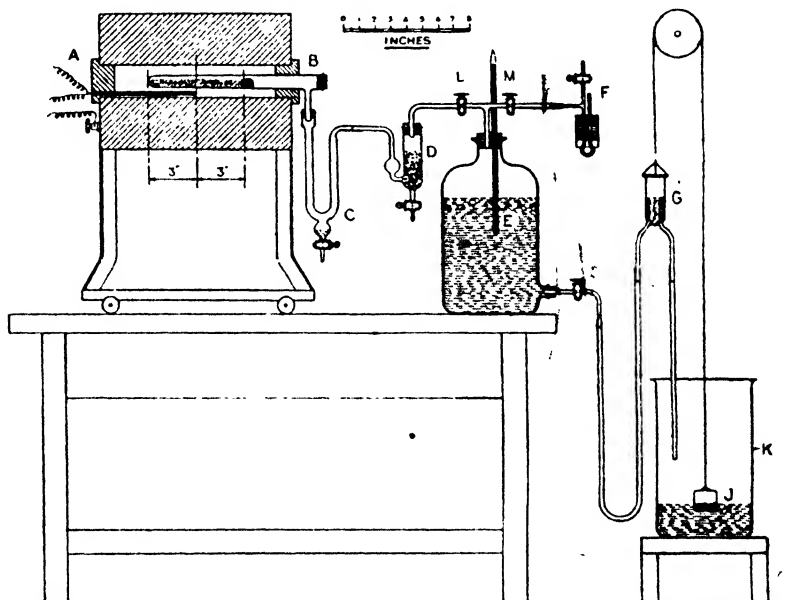

FIG. 13.—Low Temperature Carbonisation Apparatus.

(Reproduced from *Fuel Research Technical Paper No. 24*, by permission of the Controller of H.M. Stationery Office.)

The furnace A is most conveniently heated electrically, and must give a uniformly heated space at least 15 cm. long in the centre ; the temperature is regulated by reference to a thermo-junction which is in contact with the outside of the retort B at the middle of the furnace.

## Fuel Testing

The transparent silica tube B is approximately 30 cm. long, and has a diameter of about 2 cm. ; the short side-tube, about 8 mm. in diameter, is sealed in at a distance of about 2 cm. from the open end, which is closed by a rubber stopper. The tube should be smooth and of uniform bore, or may preferably have a slight taper, so that it is slightly wider at the open end.

The U-tube C acts as a condenser ; it may be cooled externally and has an extension with a capacity of at least 5 ml. for the reception of the liquid products.

The tube D, 2 to 3 cm. in diameter, by 15 cm. long, is charged with glass beads drenched with dilute sulphuric acid to absorb ammonia.

The gasholder E, filled with a mixture of equal volumes of

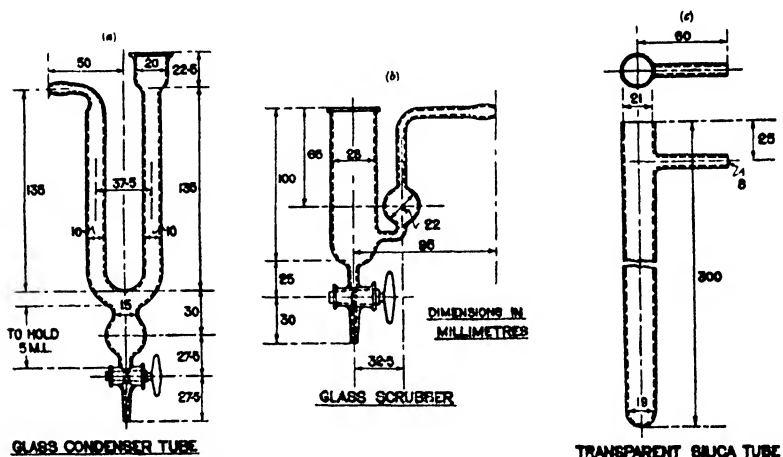

FIG. 14.—Scale Drawings of Parts of Distillation Apparatus.

(Reproduced from Fuel Research Technical Paper No. 21, by permission of the Controller of H.M. Stationery Office.)

glycerine and water, is connected to a glass reservoir G by means of a rubber tube ; this reservoir is suspended by a cord passing over a pulley, or two pulleys if frictionless bearings are used, and counter-balanced by a glass vessel containing lead shot. When gas enters E, the liquid which is displaced overflows into K (which has the same internal diameter as E) in which floats a counterpoise J. A fall in level of the liquid in E causes an equal rise in K, and the movement of J lowers G by an equal amount, thus maintaining automatically a constant pressure in the gasholder E. By suitably adjusting the height of K or of the pulleys at the beginning of an experiment, so that the level of the liquid in G is below that in E, any desired difference in level may be maintained throughout the test, provided that the connecting tube is of sufficient diameter to allow the liquid to pass freely from E to G.

### Method of Operation

The coal is ground to pass a 72-mesh B.S. sieve (=60-mesh I.M.M.), and is dried at 105° to 110° C. The gasholder is charged and the reservoir G is adjusted so that the top of the overflow tube is about 1 cm. below the level of the liquid in E, and the clean, dry U-tube C is weighed and attached. The tube B, together with a small quantity of ignited asbestos wool for use as a plug, is weighed to the nearest centigram and is charged with 20 gm. of the dried coal, spread out in a layer occupying about two-thirds the diameter of the tube and occupying a length of 6 in. and held in position by a loose plug of asbestos. The charged tube is then connected to C by means of a rubber stopper and the furnace, previously heated to 300° C., is pushed into position.

As soon as the evolution of expanded air and of gas occluded by the coal stops, the temperature of the furnace is gradually raised so that the final temperature of 550° or 600° C. is reached at the end of an hour. During this period, observations are made of the temperature at which oil first appears and at which the evolution of gas commences.

Heating at the final temperature is continued for one hour, at the end of which time the rate of evolution of gas has fallen so low that further heating gives a negligible addition to the volume; the furnace is now withdrawn, the tube B is allowed to cool, the pressure shown on F is adjusted to zero, the stop-cocks L and M are closed and B is opened.

The yield of coke is determined by weighing B when cold. After weighing, any tar is removed from the end of B, either by means of solvents or, alternatively, by burning it by heating the outside of the tube in a blow-pipe flame. The tube is then reweighed, the loss in weight being reckoned as tar and added to the weight of tar in C. The yield of coke is calculated from the weight of the cleaned tube.

The increase in the weight of C gives the yield of tar and liquor. To obtain the separate yields, the contents of C are washed into a 10 ml. graduated tube with toluene, the volume of the aqueous lower layer is measured and converted to grams, the S.G. being assumed to be 1.0. If it is difficult to obtain an accurate measurement of the volume of the aqueous portion, owing to the meniscus not being clearly defined, separation may be improved by centrifuging.

The contents of D are washed into a flask, the aqueous layer from C is added, the liquid is made alkaline by adding sufficient sodium hydroxide solution, and the ammonia is distilled into a known volume of N/10 sulphuric acid, the excess being titrated with N/10 sodium hydroxide.

## Fuel Testing

To determine the volume of gas, water is removed from K by means of a pipette, and is allowed to flow into G, which is gradually raised till the top of the inlet is on the same level as the liquid in E and the manometer F is level, any unused water being returned to K. From the weight and the specific gravity of the solution in K, the volume of gas, at the observed temperature and the prevailing atmospheric pressure, may be calculated.

The gas as prepared in a single test is contaminated with air expanded from the tube and displaced from C and D, and if a second test is made, the gas from the first should be used to displace the air from the apparatus. The gas from the second test is then relatively free from air, and may be used for analysis and for the determination of specific gravity and calorific value. If only one test is carried out, the determinations may be made on this gas, but the composition, S.G. and calorific value should be calculated on the air-free gas. Since the volume of gas in the apparatus is the same at the beginning and end of the run, no correction of the volume is necessary. It should be noted that an error may be introduced owing to the fact that the composition of the gas alters progressively throughout the assay, consequently the residual gas in the train and tube B is not of the same composition as that collected in E. The error, however, is generally only small; it may be overcome by circulating the gas through the system in order to secure adequate mixing.

A weight-balance of the products should be prepared.

## Notes on Manipulation, etc.

It is essential that the conditions laid down should be strictly adhered to if comparable results are to be obtained by different observers; the degree of accuracy which may be expected is  $\pm 0.2$  per cent. of the coal for yields of coke, tar and liquor, and  $\pm 125$  ml. per 100 gm. of coal for the volume of gas.

*Furnace.*—The furnace should be wound and lagged so that the temperature gradient towards the end is not too great and that at least 6 in. of the middle of the tube is at a uniform temperature. A new furnace should be explored by means of a thermo-junction before being taken into use and the correct position for the working couple marked on it. The provision of well-fitting ends of insulating material is essential to prevent undue cooling of the retort by circulation of air.

*Coal Layer.*—It is of great importance that the layer of coal should be of uniform depth and 6 in. long. It is convenient to use for this purpose a stout metal rod with a flattened end of diameter a little less than that of the retort. A mark may be filed on the rod to indicate the correct immersion.

## Carbonisation Assays of Coal

*Tar Adhering to Tube.*—Acetone is suitable for cleaning the film of tar from the end of the retort before weighing it a second time. The minimum quantity of solvent should be used, and it should be applied in a small pad of cotton wool fixed to the end of a wire, the tube being clamped in an inclined position to prevent the solvent from reaching the coke and the vapour should be blown out gently before weighing. As an alternative, the Author prefers to burn out the tar by means of a blow-pipe flame applied to the outside of the tube. If the retort is held in the hand while this is done, there is no danger of overheating the solid residue in the tube.

When a tube becomes devitrified through constant use it should be changed, since the rate of heating of the coal becomes less owing to the cutting off of radiation during the early stages of heating.

*Condenser.*—The shape of the condenser is chosen so that it may readily be cooled by immersion in a cylinder containing water or ice. If a tendency to formation of tar fog is observed, a small wad of asbestos wool in the outlet of the second limb is sufficient to clean the gas.

*Measurement of the Gas.*—The Author generally dispenses with the constant-head device, preferring instead to collect the glycerine and water from the gasholder in a measuring cylinder, the rate of flow being controlled so as to keep the liquid in the manometer F level. Every 5 minutes during the experiment, readings are taken of temperature, volume of gas collected and heater-current, and a chart of temperature and volume of gas is plotted against time. This variation in the method of measuring the gas does not, of course, constitute any material deviation from the standard procedure.

*Dry or Air-dried Coal.*—In the standard assay, coal dried at 105° to 110° C. is used, and the water collected is therefore "water of decomposition," less that carried forward in the gas. If the condenser is kept at about 15° C., the latter is negligible (less than 0.02 ml.). When air-dried coal is used, the water collected is "water of decomposition" plus the moisture on the air-dried coal; this has been verified by experiment.

*Spirit in Gas.*—The quantity of uncondensed liquid hydrocarbons in the gas is small, and is not normally determined. Methods which have been found to be satisfactory are absorption in activated charcoal or condensation by means of liquid air after passing the gas through a drying tube and removing carbon dioxide.

*Determination of Hydrogen Sulphide in the Gases.*—It is often required to determine the yield of hydrogen sulphide separately from the carbon dioxide, particularly when high-sulphur coal is being assayed. This determination is not easy to carry out in the gas analysis apparatus, since not only is hydrogen sulphide very soluble in mixtures of glycerine and water, but it also attacks the



## Fuel Testing

mercury in the gas analysis apparatus, and in consequence low results are likely to be obtained. It is therefore preferable to remove the  $H_2S$  from the gas during the carbonisation, conveniently as cadmium sulphide, which may then be titrated by means of standard iodine solution.

To do so, the gas after leaving the ammonia-scrubber is bubbled through a saturated neutral solution of cadmium chloride or sulphate contained in two bubblers in series. After the carbonisation is completed, the contents of the bubblers are washed out, the precipitated cadmium sulphide is filtered off and thoroughly washed with hot water. The filter and precipitate are transferred to a 500 ml. stoppered bottle, 200 ml. of distilled water are added and the bottle is shaken violently to divide the precipitate finely and to disintegrate the filter paper. An excess of  $N/10$  iodine solution is added and the liquid is acidified with dilute sulphuric acid. After being allowed to stand for a few minutes to complete the solution of the cadmium sulphide, the excess of iodine is titrated with  $N/10$  sodium thiosulphate, using starch as indicator. 1 ml.  $N/10$  iodine = 1.12 ml.  $H_2S$  at N.T.P., or 0.0017 gm.

## The Assay of Strongly Swelling Coals

The standard method is liable to give inaccurate results when applied to coals which swell strongly, since intumescence during the gas-making stage causes the charge to fill the cross-section of the retort and may force a portion of the charge out of the zone of uniform temperature. When this occurs it results in a low yield of tar and a high yield of coke. To overcome this difficulty and to afford a broad means of differentiation among these coals, the following extension of the method has been devised.

The finely ground air-dried coal is mixed thoroughly with finely ground air-dried coke or electrode carbon in such a proportion as to yield a coke which does not swell sufficiently to fill the cross-section of the retort. The proper proportions must be determined by trial, but the amount of mixture charged should always be 20 gm. Where a measure of the caking power of the coal is desired, the experiments must be continued until a mixture is found that will give a strong coke approximately equal in volume to the true volume\* of the mixture charged. The "standard" enables the caking power of coals to be distinguished up to those which just fill the cross-section of the tube after carbonisation. The addition of the carbon enables

\* By "true" volume is meant the volume occupied by the coal before it is powdered. When the coal is charged to the retort in powdered form, it occupies an appreciably greater volume, since the bulk-density of powdered coal is less than that of lump coal.

## Carbonisation Assays of Coal

those coals which have a greater swelling power to be roughly graded by the proportion of carbon necessary to produce a strong non-swelling "standard" coke. The scale of caking power is necessarily only a qualitative one, but can be supported by photographs showing the nature of the coke. Where the caking power only is in question, the procedure may be adopted without weighing the coke or collecting the volatile products.

Air-dried coal is used to eliminate changes due to the absorption of moisture during mixing. The electrode carbon or coke should be roasted before use and allowed to stand exposed to air. Its moisture content should be ascertained and the results of the assay should be calculated to dry coal. Experiment has shown that within the limits of experimental error, the addition of coke or carbon before the assay has no effect on the results.

When it is necessary to determine the appearance of the coke from the unadulterated coal, a tube of 30 mm. diameter may be substituted for the standard retort. Greater swelling is then possible before the coke projects beyond the zone of uniform temperature and it is found that the quantitative results are not affected, the larger free space in the retort being compensated by the greater volume of the coke formed.

The following standard descriptions of the cokes should be employed :

Type of Coke.	Description.
A	Pulverulent.
B	Just coherent, breaks into powder on handling.
C	Coherent, but friable on rubbing.
D	Shrunken, moderately hard.
E	Shrunken and fissured, hard.
F	Slightly shrunken and hard.
G	Hard, occupying the same volume as the original coal. "Standard" coke.
G <sub>1</sub>	Slightly swollen, hard.
G <sub>2</sub>	Moderately swollen, hard.
G <sub>3</sub>	Highly swollen, fills the tube without increase in length.
G <sub>4</sub> and upwards	Very highly swollen types. The addition of electrode carbon to produce a standard coke is essential if a statement of the swelling power is required.

### PRESENTATION OF RESULTS

The following example illustrates the method of presenting the results of a carbonisation assay :

## Fuel Testing

### CARBONISATION ASSAY OF RAWANG LIGNITE AT 700° C.

	Yields per 100 Gm. Dry Lignite.	Yields per Ton.
Solid residue . . . . .	63.10	12.6 cwt.
Liquor . . . . .	9.33	21.06 gals.
Tar (S.G. assumed 1.0) . . . . .	9.67	21.61 „
Gas (18,250 ml. at N.T.P.) . . . . .	18.63	7010 cu. ft. at S.T.P.
Ammonia . . . . .	Not determined	
	100.73	

Composition of gas— $\text{CO}_2 + \text{H}_2\text{S} = 24.05$  ;  $\text{CO} = 18.75$  ;  
 $\text{C}_n\text{H}_m = 2.30$  ;  $\text{CH}_4 = 28.50$  ;  $\text{H}_2 = 22.56$  ;  
 $\text{N}_2 = 3.85$  per cent.

Specific gravity of gas (calculated), 0.792.

First signs of water were observed at 125° C.

„ „ oils „ „ 355° C.

Gas started to be evolved at 190° to 200° C.

### GAS CALCULATIONS IN CARBONISATION ASSAYS

The following method of calculation is simple and rapid, the chances of error being thereby minimised. The dry lignite yielded 18,250 ml. of gas at N.T.P. Therefore, 100 gm. lignite gave  $\frac{18,250}{22,400} = 0.812$  gram-molecules of gas. Also, 100 lb. of dry lignite will give 0.812 lb.-mols. gas. Hence one ton of lignite will give  $0.812 \times 22.4$  lb.-mols. Now the pound-molecular volume at N.T.P. is 359 cu. ft. and the yield of gas at N.T.P. becomes  $0.812 \times 22.4 \times 359$  or 6535 cu. ft. Since volumes of gas are usually expressed at S.T.P. (60° F. and 30 in. mercury, saturated with water vapour), it is necessary to multiply by the factor (1.073) to convert from N.T.P. to S.T.P., the result being 7010 cu. ft. per ton of lignite.

To calculate the yield of gas as a percentage by weight of the coal, it is simplest to calculate the number of millilitres of each constituent of the gas. If this figure is divided by 22,400, the quotient is the number of gram-molecules of the constituent, and the product of this with the molecular weight of the constituent gives the number of grams thereof per 100 gm. of lignite.

Thus, the unsaturated hydrocarbons ( $\text{C}_n\text{H}_m$ ): ml. per 100 gm. lignite =  $18,250 \times \frac{2.3}{100} = 420$  ml.  $\frac{420}{22,400} = 0.0187$  gm.-mols., and,

## Low Temperature Carbonisation

taking the unsaturated hydrocarbons to be propylene, which is a common assumption,  $0.0187 \times 42 = 0.79$  gm.

It is convenient to set out the figures in a table :

	Per Cent. in Air-free Gas.	Ml. per 100 Gm. Lignite.	Gm.-Mols. per 100 Gm. Lignite.	Gm. per 100 Gm. Lignite.
CO <sub>2</sub>	24.05	4389	0.1958	8.62
CO	18.75	3423	0.1527	4.27
C <sub>n</sub> H <sub>m</sub>	2.30	420	0.0187	0.79
CH <sub>4</sub>	28.50	5201	0.2320	3.71
H <sub>2</sub>	22.55	4114	0.1815	0.36
N <sub>2</sub>	3.85	703	0.0313	0.88
	100.00	18,250	0.812	18.63

Since 0.812 gm.-mols. of gas weigh 18.63 gm., the molecular weight is  $\frac{18.63}{0.812}$  or 22.94, and, taking the molecular weight of air as 28.98, the specific gravity of the dry gas relative to air is  $\frac{22.94}{28.98}$  or 0.792.

### CORRELATION WITH LARGE-SCALE LOW TEMPERATURE CARBONISATION

The assay provides not only a means of classifying coals but also, without change or modification, a measurement of the yields of products obtainable on carbonisation of the coal at the same temperature on a large scale. This is possible only by first comparing the assay results with the data obtained by the treatment of the same coal in the particular plant in question. Since the temperature of the assay is 600° C., the method is specially adapted for the evaluation of coal for low temperature carbonisation. The yield of coke will differ only slightly from that of the assay if the full working temperature is realised, but the yields of gas and tar will vary with each different plant.

The type of coal which produces a "standard" coke in the assay is that which produces from fine coal, by external heating, in thin layers (4 to 7 in.), a hard, compact coke which shrinks slightly during formation. Any coal which produces in the assay a coke appreciably more friable than the "standard" will not produce a satisfactory smokeless fuel from slack coal. A coal which yields a more swollen coke in the assay will tend to yield a more porous coke

## Fuel Testing

on a large scale, and with the increase of swelling, the tendency to hanging or sticking in a vertical retort will also increase. The full interpretation of this "caking power" will vary with the type of plant and will only be achieved by the trial of a variety of coals.

*Tar.*—The yield of tar in the assay approaches the maximum obtainable from the coal by external heating, and if this be accepted as a basis of comparison, the tar-producing efficiency of any plant may be gauged. The steel retorts at the Fuel Research Station gave consistent tar yields with several types of coal, equivalent to 60 per cent. of that given by the assay. Other comparative figures from the Fuel Research Station records are : Parker retort installation 68, Crozier retort 68, and Freeman retort 84 per cent.

The factor depends not only on the retorting system but on the size and nature of the coal used ; it will be greater with a coal of comparatively large particle-size which allows the vapours to escape readily from a zone in which intumescence has not yet taken place, or where the method of carbonisation or the type of coal allows the volatile products to escape rapidly. The factor, therefore, for any given plant will tend to be greater for coals giving high yields of tar. Before assuming assay factors for any plant it is necessary to take into account both the type and size of coal and to employ a different factor for each combination. It may at present be considered that from 60 to 80 per cent. is the factor obtainable by processes which produce a robust smokeless fuel.

*Condensable Spirit.*—The yield of condensable spirit in the gas is not determined in the assay, since the quantity, about 0.1 gm., is too small for accurate measurement. A determination can, if necessary, be made by the provision of a drying tube and an absorption tube after the scrubber. The absorbent may be either activated carbon or silica gel.

*Gas.*—The yield of gas is less easy to correlate, since its composition depends even more upon the type of retort and the possibility of entry of air or flue-gas. If the retort system is gas-tight, the yield of gas will depend on the nature and size of the coal and the extent to which cracking takes place in the retort. The most important difference between laboratory and large-scale carbonisation is the rate of input of heat into the coal. In the assay, the surface-mass ratio is high, and the reactions initiated up to, say, 600° C. are almost completed after 60 minutes at that temperature. In large-scale retorts, where the surface-mass ratio is low, the rate of heating may be so slow that the contents may never reach a state of equilibrium before the coke is discharged. The following example from comparative tests on the steel retorts at the Fuel Research Station illustrates the difference that may occur between the composition of the gases from the assay and the retorts :

## High Temperature Carbonisation

Gas from Assay.			Gas from Retorts.
	1st Hour.	Average.	
CO <sub>2</sub> , etc. . . .	9.0	6.9	6.6
CO . . . . .	6.6	5.7	3.5
C <sub>n</sub> H <sub>m</sub> . . . . .	3.5	2.5	7.2
C <sub>n</sub> H <sub>1n-2</sub> . . . .	48.4	45.3	60.3
H <sub>1</sub> . . . . .	27.4	33.8	18.5
N <sub>2</sub> . . . . .	5.1	5.8	3.9
"n" in saturated hydrocarbons .	1.31	1.26	1.39

The difference in composition between the gas from the assay and from the retorts is marked. The reason is the high yield of gaseous hydrocarbons introduced into the retort gas by "cracking," while the low yield of hydrogen indicates that the coal in the retorts had not attained as high a temperature as in the assay. The volumes and thermal yields differ less than the compositions, and it is on these bases only that correlation factors are possible.

### THE HIGH TEMPERATURE CARBONISATION ASSAY OF COAL

The chief difficulty in devising a satisfactory laboratory high temperature assay lies in reproducing the cracking of the volatile products which takes place in the plant, giving rise to the high yields of gas resulting from high temperatures of carbonisation. In the method to be described, this is accomplished by causing the volatile products to traverse a "cracking zone" consisting of a length of broken silica brick heated to 800° C., whereby a certain proportion of the tar and some of the hydrocarbons in the gas are cracked to permanent gases, thus increasing the volume of the gas at the expense of part of the tar and of the more complex hydrocarbons.

### Description of Apparatus

The apparatus is represented diagrammatically in Fig. 15, which shows details of the packing of the retort. The furnaces A, A', are most conveniently heated by electricity, and should be capable of maintaining at uniform temperature at least 3 in. of the middle of A' and the first 8 in. of A nearest to A'. This ensures uniform conditions over both the charge of coal and the cracking zone. The retort

### Fuel Testing

is exactly similar to that used in the low temperature assay, and is connected to a condenser, scrubber and 10-litre gasholder fitted

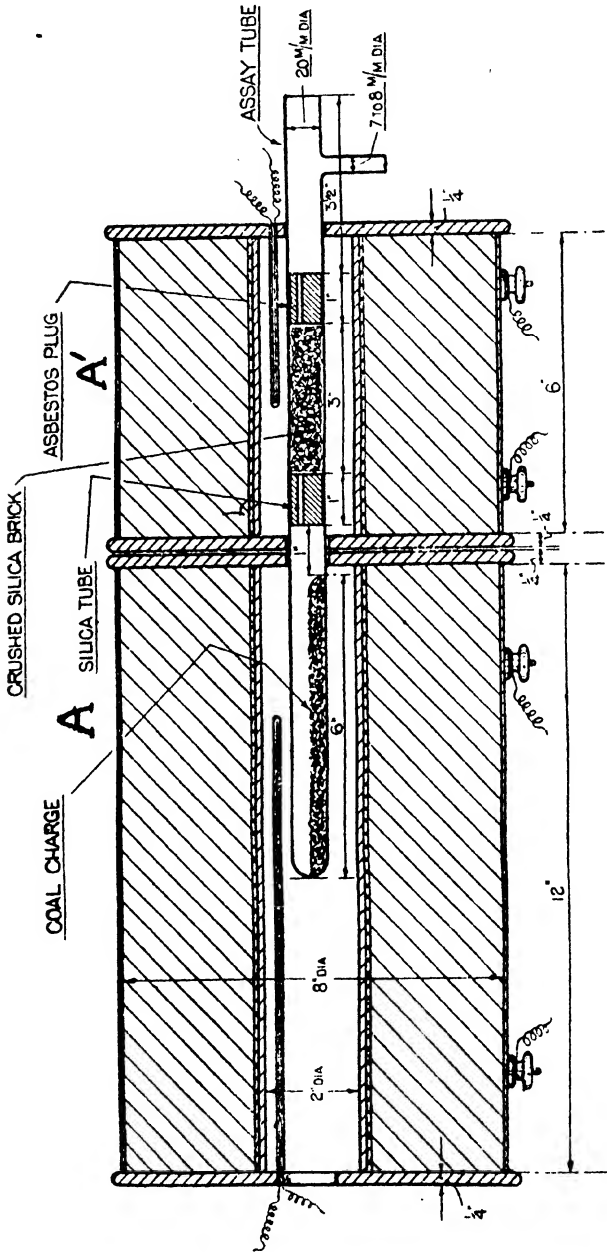

FIG. 15.—Details of Packing of the Distillation Tube. High Temperature Assay.  
 (Reproduced from Fuel Research Technical Paper No. 24, by permission of the Controller of H.M. Stationery Office.)

with a constant-head device. The condenser must be cooled externally in a beaker containing cold water or ice.

## High Temperature Carbonisation

### Method of Operation

The coal is air-dried and ground to pass a 72-mesh B.S. sieve. The right-hand limb of the condenser is fitted with a fairly loose plug of asbestos to remove tar fog from the gas. The transparent silica retort is weighed to the nearest centigram and is charged with 20 gm. of air-dried coal. The first asbestos plug is then inserted and pushed into position so as to leave a space of 7 in. from the closed end of the retort.

Crushed silica brick (14- to 25-mesh B.S. sieve) which has previously been roasted, is then added and then the second asbestos plug; the total weight of the brick and the two plugs should be 30 gm. These plugs are made from asbestos wool moulded into shape wet, and having a piece of silica tube 3 to 4 mm. in diameter through the centre. The whole is kept in shape by a binding of asbestos and should be roasted before use.

The coal is spread in an even layer 6 in. long and the charged tube is connected by a rubber stopper to the condenser. The furnace A', previously heated to 800° C., is pushed forward into a position so that the 1-in. space between the coal and asbestos plug is at the junction of the two furnaces. In practice, it is found advantageous to raise the temperature initially to 850° C., since the insertion of the coal tube lowers the temperature by about 50° C. When the temperature is steady at 800° C., usually after from 5 to 10 minutes, the furnace A, previously heated to 300° C., is run into position close to the small furnace. The temperature of A is then raised at a uniform rate so as to reach 900° C. at the end of 2 hours. Heating at the final temperature is continued during 30 minutes, at the end of which time the rate of evolution of gas has become negligible. The furnaces are then withdrawn, the retort is allowed to cool, the pressure on the manometer is adjusted to zero, the stop-cocks on the gasholder are closed, and the retort is opened. The yield of products is obtained as described in the low temperature assay.

### Composition and Specific Gravity of the Average Gas

The true average composition and specific gravity of the gas are not represented by the contents of the holder, partly owing to the inclusion of air and partly owing to the presence of gas in the absorption train, which is of different composition. The free volume of the train is 200 ml. in a total of about 7000 ml., so that the effect is small. To obtain values as close as possible to the true values, the gas in the holder should be circulated several times through the train and the analysis and specific gravity of the mixture should be calculated to an air-free basis.



## Fuel Testing

The average gas from the assay is very similar to that from the same coal when carbonised in horizontal retorts, but may differ considerably from that produced in vertical retorts, owing to the injection of steam. The gas from the assay differs from both in that it contains no paraffin hydrocarbons higher than methane.

### Scope of Method

The assay is intended for the rapid evaluation of coals for the carbonisation industries. The essentials, therefore, are the yields of gas by volume and by heat units, of tar, liquor, ammonium sulphate and coke, and the nature of the coke. The most important of these for the gas industry are the volume of gas and the gaseous therms. Considerations such as yields of benzol or naphthalene are only subsidiary, since coals are unlikely to be selected from this point of view. The yields of the main products may be related to those obtained in practice by correlation factors; these factors should be as nearly as possible unity, but this can be possible only for one type of carbonising system unless the conditions of assay are altered, which is obviously undesirable. With the same conditions of assay the factors will vary with the type of plant, to a less extent with the individual plant, and with the type of coal and its size.

Excluding variation due to the individual plant, the chief variables are :

Type of plant	. .	Gas retort—vertical continuous.
” ”	. .	Gas retort—horizontal.
” ”	. .	Gas retort—inclined.
” ”	. .	Coke oven—several types.
Type of coal	. .	Medium to highly caking.
Size of coal	. .	Run of mine, sized coal, graded coal.
Other variables	. .	Steam to retorts, carbonising temperature.

When it is considered that many of these variables are interdependent and that, in addition, there are the variations in individual plants, for one standard assay there must be a number of factors. In investigations at the Fuel Research Station it has been possible to obtain data which show the variation in yields caused by variations in the nature and size of the coal in two types of retort, horizontal and vertical (Glover West). Only the wide adoption of the method can indicate the limits of the variables. Each user should obtain factors for himself to cover the plants operated and the types of coal in use: he would then, by analogy, be able to assess the value of any new coal by laboratory examination alone. The full value of the method can only be realised when all the variables have been taken into account.

It is possible that the variation in the factors for some of the

## High Temperature Assay

variables may be sufficiently small to permit the use of mean values, so that only a relatively limited number of factors will finally enter into consideration.

### CORRELATION OF THE HIGH TEMPERATURE ASSAY WITH WORKS PRACTICE

The assay is standardised to give results closely correlated with horizontal retorts, since the conditions therein are more readily simulated, in that (a) the charge is static, (b) the high yield of gas arises from rapid heating and cracking over the hot surface of the retort, and (c) no complications are introduced by reactions such as are caused by "steaming." The factors obtained for the Fuel Research Board tests are not far from unity in comparison with horizontal retort practice. The factors for coke-oven practice should also not be far from unity, but no data are available. The important consideration in coke-ovens is, of course, the coke.

The accuracy of the method is high ; eight tests on one coal gave results summarised in the table below, in which all yields are expressed on 100 gm. of coal :

	Coke.	Tar.	Liquor.	Gas, MI.	Ammonia.
Mean . . .	75.02	3.28	6.21	32,040	0.270
Extreme values	74.90 to 75.25	3.10 to 3.60	6.00 to 6.25	31,500 to 32,405	0.265 to 0.275
Mean difference	0.07	0.13	0.07	271	0.005

The differences in composition of the gas obtained in the eight assays were negligible.

### Horizontal Gas Retorts

The variation in yield of coke is small and may be regarded as negligible. The yield of tar varies with the size of the coal, being higher with coal of large particle size, and it also increases as the caking power of the coal decreases. The effect of size is more marked with coal of lower caking power, presumably because fusion of swelling coal destroys the effect of size of particle soon after charging.

The correlation of yields of liquor is not close, owing to the cracking which is necessary to produce high yields of gas. The factor retort/assay is of the order of 0.6.

The important item in the correlation is the yield of gas. On a thermal basis, the factors are sufficiently near unity to be taken as such. On a volumetric basis the factor is again close to unity for gas coals of high caking power, but is greater than unity, i.e. the

## Fuel Testing

yield in the retort is high if coal of low caking power and relatively large size is used.

The variations in the factors are given in Table XIV, the factors being retort/assay yield.

TABLE XIV  
CORRELATION FACTORS FOR HORIZONTAL GAS RETORTS

Factor for	Size Decreasing. 1 → 3	Type of Coal.		
		1	2	3
		Caking Power Decreasing. →		
Volume of gas .	1	1.03	1.00	1.13
	2	1.00	1.00	1.06
	3	1.01	1.00	1.08
Gaseous therms .	1	0.99	1.00	1.00
	2	1.01	1.02	1.00
	3	1.00	1.02	1.02
Tar . . . .	1	1.40	1.68	1.68
	2	1.17	1.42	1.52
	3	1.27	1.33	1.25
Ammonia . . .	1	0.79	0.92	0.92
	2	0.86	0.91	0.92
	3	0.82	0.95	0.83
Liquor . . . .	1	0.57	0.72	0.58
	2	0.64	0.66	0.49
	3	0.60	0.65	0.44
Coke . . . .	1	0.98	0.96	0.97
	2	0.97	0.97	0.99
	3	0.97	0.97	1.00

The value of this table is fully realised only by considering at the same time the nature of the coke ; this is best done by comparison with the photographs in Plate III.

Type.	Campredon Caking Index.	Nature of Coke.
1	24	Swollen and porous.
2	14	Hard and compact.
3	12	Hard, but shrunken and slightly friable.

PLATE III



Assay Cokes from Three Types of Bituminous Coal.

- |                                 |   |   |     |
|---------------------------------|---|---|-----|
| (1) Mitchell Main, Caking index | . | . | 24- |
| (2) Dalton Main, Caking index   | . | . | 14  |
| (3) Shafton, Caking index       | . | . | 12  |

(All actual size.)

[To face page 110.]



## High Temperature Assay

Coal of type 1 gives in practice a large and strong coke, those of types 2 and 3 give progressively weaker cokes and of smaller size. The coke from type 3 is sufficiently weak to be unsatisfactory for sale as gas-coke.

While the table is capable of amplification to cover the whole range of bituminous coals, the three types of coal as represented by their assay cokes form a series from which the value of any unknown coal could be assessed in terms of horizontal retorts. The actual values are, of course, applicable only to the installation at the Fuel Research Station, and differences might be expected with other installations.

### Continuous Vertical Retorts

The conditions of carbonisation were: mean temperature in combustion chambers 1260° C., mean throughout 2.5 tons per day, steam to retorts 10 per cent. by weight on the coal carbonised.

The variation in the yield of coke is small, and shows a slight increase with decrease of caking power; the use of steam in the retorts necessarily makes the yield of coke less than that in the assay. The yield of tar shows the same variation with type and size of coal as in horizontal retorts, but the correlation factor, retorts/assay, is much greater owing to the action of the steam. Although a satisfactory correlation of the yields of liquor is not possible, owing to the use of steam which is not all decomposed, the figures are given in Table XV for the sake of completeness.

It is necessary to take the nature of the coke into account, as previously described. The effects of size and type again fall into a definite series which indicates that, by including other types of coal, graphs could be drawn in terms of caking index, or type of coke, to include all variables.

*Continuous Vertical Retorts Using 5 per cent. of Steam.*—Further data were available for eight coals whose caking power varied from less than medium to strongly caking. The mean temperature in the combustion chambers was 1260° C., the mean throughout 2.5 tons per retort per day and the steam used was 5 per cent. by weight of the coal. The effect of size, which the experiments have shown to be considerable, could not, unfortunately, be determined in this series, since the coals were all run-of-mine, crushed so that the largest lumps were 4-in. cubes, so that the proportions of the different sizes must have varied. Table XVI shows that the factors are very similar for five fusible coals whose caking index (Campredon) is over 24; this seems to indicate that the variation in size with the different coals was small. With coals of lower caking power, "Kinneil" and "Ravine," the effect of caking power is again apparent in the

# Fuel Testing

TABLE XV

CORRELATION FACTORS FOR CONTINUOUS VERTICAL RETORTS USING 10 PER CENT. STEAM

Factor for	Size Decreasing. 1 → 3	Type of Coal.		
		1	2	3
		Caking Power Decreasing. →		
Volume of gas .	1	1.62	1.63	1.80
	2	1.46	1.54	1.76
	3	1.33	1.50	1.60
Gaseous therms .	1	1.30	1.27	1.29
	2	1.23	1.28	1.36
	3	1.19	1.28	1.33
Tar . . .	1	1.77	2.22	2.42
	2	1.32	1.58	1.88
	3	1.20	1.26	1.57
Ammonia . .	1	—	0.90	0.87
	2	0.66	0.76	0.88
	3	0.69	0.75	0.93
Liquor . . .	1	1.22	1.31	0.83
	2	1.88	1.24	0.73
	3	2.01	1.16	0.67
Coke . . .	1	0.89	0.85	0.86
	2	0.92	0.88	0.88
	3	0.92	0.90	0.90

TABLE XVI

CORRELATION FACTORS FOR CONTINUOUS VERTICAL RETORTS USING 5 PER CENT. STEAM

Coal.	Fusible.	Kinnell.	Wearmouth.	Mitchell Main, Nuts.
	Run-of-Mine.			
Volume of gas .	1.28	1.44	1.20	1.27
Gaseous therms .	1.13	1.14	1.15	1.10
Tar . . .	1.44	1.51	1.38	1.42
Ammonia . . .	0.72	—	0.65	0.62
Liquor . . .	1.24	0.76	1.86	1.18
Coke . . .	0.95	0.90	0.92	0.94

## High Temperature Assay

higher yields of gas and tar. Factors for "Mitchell Main" are included, although this coal was in the form of 1-in. nuts, since it is regarded as a standard of comparison. The factors are very similar to the average for the fusible coals.

*Summary.*—From the correlation data it may be concluded that the factors for the calculation of retort yields from those of the assay vary with the type of retort and with the type and size of the coal. They may also vary with individual retorts of the same type, though much less.

If the assay is used to evaluate untried coals, the results must be interpreted in terms of the type of coal, as shown by the caking index, or the type of coke produced in the assay. The results in the plant may then be deduced by analogy from previous correlations in the same plant with similar coals, using the factors corresponding to the type and size of coal to be carbonised.

Within the class of highly swelling coals normally used for the manufacture of gas or coke, the factors for similarly sized coal such as crushed run-of-mine may be assessed on mean values for the class.

## BIBLIOGRAPHY

T. Gray and J. G. King, "The Assay of Coal for Carbonisation Purposes." Fuel Research Board, Technical Paper No. 1, 1921.

J. G. King, C. Tasker, and L. J. Edgcombe, "The Assay of Coal for Carbonisation Purposes," Part II. Fuel Research Board, Technical Paper No. 21, 1929.

J. G. King and L. J. Edgcombe, "The Assay of Coal for Carbonisation Purposes," Part III. Fuel Research Board, Technical Paper No. 24, 1930.

"Methods of Analysis of Coal." Fuel Research Board, Survey Paper No. 44, 1940.



## CHAPTER VII

### THE MINERAL MATTER IN COAL

ALL coal brought to the pit-head contains a certain proportion of mineral matter, either finely divided and more or less uniformly distributed throughout the coal, when it is known as "inherent" or "intrinsic" mineral matter, or segregated into bands or lumps of varying thickness and size, when it is termed "extrinsic" or "free" mineral matter.

Intrinsic mineral matter owes its origin to the inorganic salts essential to plant life which were present in the vegetation from which the coal was formed, to inorganic salts concentrated by absorption and adsorption in the plant substance, and to dust brought down by wind and rain. Owing to its fine state of division and to its intimate association with the coal substance, intrinsic mineral matter is not removable by the ordinary methods of cleaning.

Extrinsic mineral matter is almost always present; it consists of "dirt" partings of shale or clay, of films and concretions of sulphide of iron ( $\text{FeS}_2$ ) as pyrite or marcasite, of bands of the carbonates of lime, magnesia and iron and films of sulphate of lime as gypsum ( $\text{CaSO}_4 \cdot 2\text{H}_2\text{O}$ ). Part of this mineral matter was deposited with the original vegetable debris and part was introduced later by percolating solutions and suspensions. In addition, during mining, quantities of inorganic material are introduced from the roof and floor of the seam and from the thicker partings of shale which become broken during the winning operation and cannot be altogether excluded from the product. Extrinsic mineral matter, being less intimately associated with the coal substance than intrinsic mineral matter may be more or less completely removed by cleaning.

When coal is burned, the following changes in composition of the mineral matter take place :

Shale, which consists of a mixture of varying proportions of hydrated silicates of aluminium, together with more or less fine quartzose silt, when heated to about  $600^\circ \text{C}$ ., loses combined water. J. G. King, M. B. Maries and H. E. Crossley<sup>1</sup> report that air-dried clays associated with British coals contain from 6 to 11 per cent. of combined water, depending on the district from which they are derived; they also suggest factors for converting ash to shale as follows :

## Mineral Matter in Coal

Clay from	Per Cent. Combined Water.	Factor Shale/Ash.
England . . . .	8	1.09
Scotland . . . .	11	1.13
Wales . . . .	6	1.07

Carbonates of lime, magnesia and iron are decomposed with loss of carbon dioxide, leaving oxides.

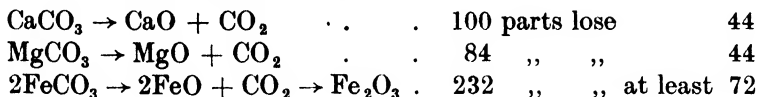

Sulphide of iron becomes oxidised to ferric oxide,



On the other hand, there is usually a gain owing to the fixation of part of the organic or pyritic sulphur as  $\text{SO}_3$  combined with oxides of lime or of the alkali metals.

Chlorides of the alkali metals may be completely volatilised, although this is generally not of much moment in causing reduction in weight of the residual mineral matter since the quantity of chlorides present is usually only small.

The result is that the percentage of ash determined by incineration is below the percentage of original mineral matter, the difference depending on the nature of the parent inorganic materials; in any case, the deficiency is likely to be at least from 8 to 10 per cent.

King, Maries and Crossley (*loc. cit.*) derive the following formula for calculating the percentage mineral matter in coal from the ash :

$$M = 1.09 \text{ ash} + 0.5 S_{\text{pyr}} - 1.1 \text{ SO}_{3\text{ash}} + \text{SO}_{3\text{coal}} + 0.5 \text{ Cl.}$$

The formula assumes that the water of hydration of clay is 8 per cent., that 3 parts  $\text{FeS}_2$  form 2 parts  $\text{Fe}_2\text{O}_3$  and that half the chlorine is inorganically combined.

With very pure coals (containing from 2 to 5 per cent. of mineral matter) the discrepancy between the mineral matter and the ash is of less importance than if the coal be dirty. In the case of a coal containing 10 per cent. of dirt in the form of shale with 10 per cent. of combined water, neglecting any other inorganic matter, in the incineration for ash, the solid residue would be 9 per cent. on the coal, while in the combustion for carbon and hydrogen, 100 gm. of coal would give 1.0 gm. of water in excess of that derived from the organic hydrogen, which is equivalent to a positive error of 0.11 per cent. of hydrogen. The oxygen, being determined by difference,

## Fuel Testing

bears all the errors of the other determinations, and by reason of the presence of the shale alone would therefore be 0.89 per cent. above the true value, and when calculated to dry ashless coal, the error would be increased to 1.0 per cent., and with higher mineral matter, the errors would be increased in direct proportion. It is therefore evident that conclusions as to the composition and calorific value of the pure coal substance based on the examination of any but low-ash coals are liable to be misleading.

When dealing with rocks such as the oil-shales, which may yield up to 80 per cent. of ash in incineration, it is not satisfactory to employ the empirical formula of King, Maries and Crossley to arrive at the percentage of mineral matter. The organic matter must be separated either by physical or by chemical means as outlined on page 59.

Mineral matter in coal serves no useful purposes, but is a source of loss, extra cost and embarrassment. It is therefore desirable that coal should be cleaned before distribution. Among the advantages accruing from coal cleaning are the following: (i) If coal be cleaned at the pit-head, transport and handling charges are reduced. (ii) The efficiency of utilisation increases out of proportion to the increase in combustible, since not only is the ash an inert constituent which must be discharged at the temperature of the furnace, but there is always a loss of combustible with it; this loss rises out of proportion to the mineral content of the coal. (iii) The removal of ash and clinker from the furnace increases the costs of plant and labour; maintenance and repair charges are increased by the action of the hot ash on the furnace lining, and mechanical damage is likely to result from the poking and slicing necessary to dislodge clinker which has stuck. (iv) Objectionable elements, such as sulphur and phosphorus, may be reduced, with improvement in the quality of the coke if the coal is carbonised.

On the other hand, as has been pointed out by F. S. Sinnatt and C. G. Wood,<sup>2</sup> excessive purification may sometimes give a product whose ash is of relatively low melting-point, and may thus actually reduce the industrial value of the coal for certain purposes.

### WASHABILITY TESTS OF COAL

It is important to be able to discriminate between intrinsic mineral matter which is not removable by cleaning and extrinsic mineral matter which may be reduced. A means is provided by X-ray examination, the "dirt" in the coal being relatively opaque, while the coal-substance, with its finely divided mineral matter, is relatively transparent: in consequence, in the radiograph, the intrinsic mineral matter appears as dark bands and patches in a lighter field of coal.

## Washability Tests of Coal

Laboratory tests consist in making specific gravity analyses of the sample which is divided into a series of fractions, each containing particles within narrow limits of specific gravity, and ranging from fractions of low specific gravity, which consist of practically pure coal, to fractions of higher specific gravity containing more and more impurity, till the last fraction is made up almost entirely of "dirt."

Separation may be carried out either by means of a hand jig or by means of liquids of specific gravity intermediate between that of the coal and of the mineral matter.

The question of the sample to be used in washing tests of coal is important. The size of the coal must be the same as is to be used in the cleaning plant; no finer crushing is admissible, otherwise a more complete separation of compound lumps consisting of coal and dirt would occur and the results would not be comparable with those obtained in the plant. Since the specific gravity is influenced by the presence of moisture, it is incorrect to dry the sample before the test; apart from alteration in specific gravity of some or all parts of the sample, disintegration may be brought about by drying. The quantity taken for the test must be adequate to ensure that all the kinds of particles met with in the coal to be cleaned are included in their correct proportions. M. W. Blythe and D. O'Shea<sup>3</sup> recommend that at least 2000 particles should be present, and they suggest that rational quantities to take are :

Coal through $\frac{1}{16}$ in. screen	.	.	10 gm.	
„ on $\frac{1}{16}$ in. through $\frac{1}{8}$ in.	.	.	50 „	
„ „ $\frac{1}{8}$ „ „ $\frac{1}{4}$ „	.	.	200 „	
„ „ $\frac{1}{4}$ „ „ $\frac{1}{2}$ „	.	.	1,000 „	
„ „ $\frac{1}{2}$ „	.	.	25,000 „	(56 lb.)

To determine completely the washing characteristics of a coal, the sample should be screened between narrow limits and each fraction should be tested separately. Sometimes one size is less amenable to cleaning than the others; hence if the test is made on the unscreened coal, an unfavourable opinion of the washing characteristics may be formed, whereas it may happen that while a portion of the coal, covering a relatively narrow range of sizes, is difficult to clean, the remainder may present no difficulty. This information would probably be masked if preliminary screening had not preceded the cleaning test.

W. R. Chapman and R. A. Mott<sup>4</sup> suggest that suitable sizes of coal for testing in the laboratory are: 1 in. ; - 1 in. +  $\frac{3}{4}$  in. ; -  $\frac{3}{4}$  in. +  $\frac{1}{2}$  in. ; -  $\frac{1}{2}$  in. +  $\frac{3}{8}$  in. ; -  $\frac{3}{8}$  in. ; +  $\frac{1}{4}$  in. ; -  $\frac{1}{4}$  in. +  $\frac{1}{8}$  in. ; -  $\frac{1}{8}$  in. +  $\frac{1}{16}$  in. ; and -  $\frac{1}{16}$  in. A weighed quantity of the coal should therefore be screened between these or similar limits and each fraction should be weighed and tested separately.

## Fuel Testing

### The Henry Tube

This consists of a brass tube, 28 to 30 in. long and up to 4 in. in diameter, round the upper edge of which is fixed a shallow tray for convenience in removing samples (see Fig. 16). Handles are fixed just below the tray for convenience in jiggling the tube in the water-bath. About an inch above the bottom of the tube, a brass collar

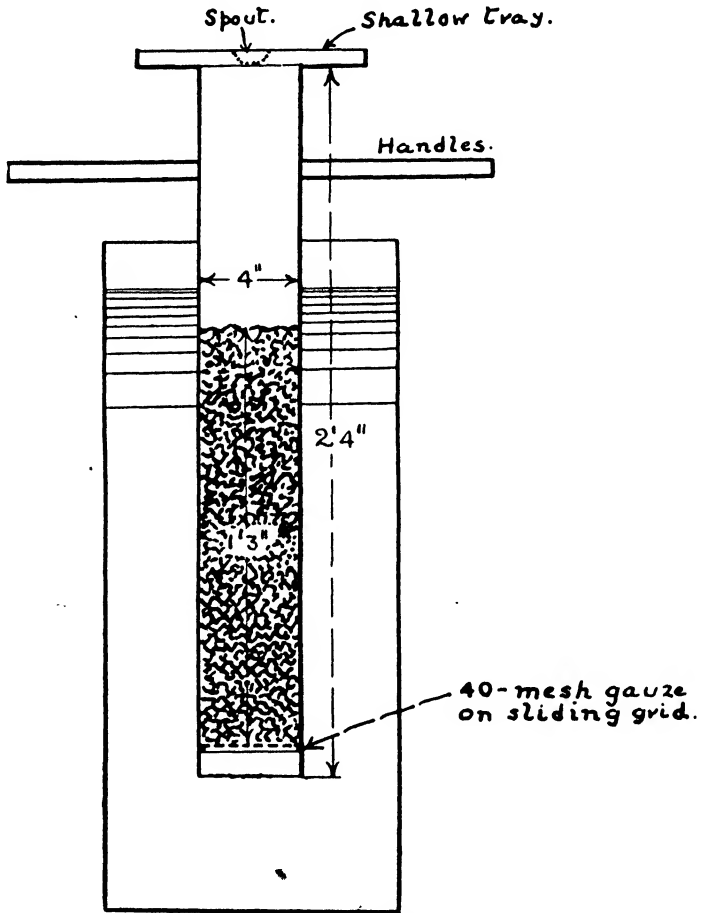

FIG. 16.—The Henry Tube for Washability Tests.

is soldered round the interior; this serves to support a brass disc pierced with holes, on which rests a wire gauze (40-mesh), the gauze and disc being held in position by set-screws. A large water vessel, which may be 30 in. deep and of diameter 2 in. greater than that of the tube, is also provided.

The water vessel is nearly filled with water and the jig tube is lowered into it. A suitable quantity of coal to fill the tube to a

## Washability Tests of Coal

depth of about 15 in. is weighed and poured into the tube ; with a 4-in. tube, from 1200 to 1600 gm. of coal are necessary. The tube is then jiggged up and down in the water-bath for about a minute. It is advisable that the downward stroke should be made with some force while the upward stroke should be slow ; by this means the particles of coal are forced violently upwards and allowed to settle slowly, whereby they tend to sort themselves out more or less according to their specific gravities ; the clean coal, which has the lowest specific gravity, works upwards to the top of the column, while the heavier material (the " dirt ") is concentrated at the bottom. The time of jiggging and the number of strokes should be standardised, since otherwise, the results on different samples of coal will not be comparable ; moreover, by adhering to a definite routine, the personal element is reduced to a minimum. Where a jig washer is used on the plant, it is a good plan to stand the Henry tube in the washer-box for 10 or 20 minutes (the time being standardised and adhered to in all tests), the result being that plant conditions are as nearly as possible secured in the laboratory test.

The jig tube is removed from the water-bath and allowed to drain ; the set-screws holding the grid and gauze are removed and the column of coal is pushed cautiously upwards by means of a wooden rod. When a plug of coal about half an inch long protrudes from the top of the tube, it is carefully scraped via the tray into a weighed basin and the rest of the contents are removed similarly. The first two or three layers should be about half an inch thick, since they are practically pure coal and should contain little impurity other than inherent mineral matter. After two or three small samples have thus been removed, layers about an inch thick may be taken off until about 3 in. of material remain in the tube. The remainder of the sample should be taken off in thin layers, since towards the bottom of the tube the sample consists of more and more dirt, while the bottom layer should contain practically no coal.

Each layer is dried, weighed, finely ground, and the ash is determined.

The results of the test are worked up and tabulated in nine columns as shown in Table XVII. Column I gives the number of the layer, Column II the weight of the dried layer in grams. The weight of each layer is calculated as a percentage of the weight of the dry, washed coal and entered in Column III, while the cumulative percentage weight to the bottom of each layer gives Column IV. Column V consists of the percentage of ash on each layer, while in Column VI the cumulative per cent. weight to the middle point of each layer is set out.

From the data, three curves are plotted (Fig. 17):

## Fuel Testing

(i) *The Instantaneous Ash Curve.*—The average ash on each layer is plotted against the percentage weight from the top of the coal to the middle of the layer, i.e. Column V against Column VI. By careful extrapolation to 0 and 100 per cent. of the weight, the inherent ash on the coal and the ash on the dirt unmixed with coal are arrived at.

TABLE XVII

WASHING TEST No. 3. COAL No. 4

Coal screened through 6-mesh, on 20-mesh

292.5 gm. coal at 8.6 per cent. moisture, equivalent to 267 gm. dry coal

Layer Number.	Weight of Layer. Gm.	Per Cent. Weight of Total Dry Washed Coal.	Cumulative Per Cent. Weight to Bottom of Layer.	Average Per Cent. Ash on Layer.	Cumulative Per Cent. Weight to Middle of Layer.	Integral Ash on Coal. Per Cent.	Cumulative Per Cent. Weight from Bottom.	Integral Ash on Dirt. Per Cent.
I	II	III	IV	V	VI	VII	VIII	IX
1	16.2	6.1	6.1	5.45	3.05	5.45	100	18.55
2	24.5	9.3	15.4	4.6	10.75	4.93	93.9	19.4
3	30.9	11.7	27.1	5.55	21.25	5.21	84.6	21.0
4	14.0	5.3	32.4	6.45	29.75	5.41	72.9	23.5
5	22.0	8.3	40.7	7.0	36.55	5.73	67.6	24.9
6	22.9	8.7	49.4	7.0	45.05	5.97	59.3	27.9
7	21.6	8.2	57.6	7.65	53.5	6.20	50.6	30.9
8	12.3	4.7	62.3	7.20	59.95	6.27	42.4	35.4
9	15.8	6.0	68.3	7.45	65.3	6.37	37.7	38.9
10	17.8	6.7	75.0	12.9	71.65	6.98	31.7	44.8
11	17.7	6.7	81.7	26.0	78.35	8.43	25.0	53.3
12	16.1	6.1	87.8	46.6	84.75	11.03	18.3	63.3
13	32.5	12.2	100.0	71.7	93.0	18.55	12.2	71.7
	264.3							

Loss on washing, 2.7 gm. or 1.0 per cent.

(ii) *The Integral Ash Curve of the Coal.*—The true average ash of the coal to the bottom of each layer is calculated (Col. VII) and plotted against the percentage weight to the bottom of the layer. This curve starts at the percentage of ash on the top layer and ends at the true average ash on the coal.

(iii) *The Integral Ash Curve of the Dirt.*—This curve is complementary to (ii) and is constructed by starting from the bottom layer, calculating the true average ash to the top of each layer and plotting this against the percentage weight to the top of the layer (Col. IX against Col. VIII). One end of this curve is obviously at

## Testing Washability of Coal

the true average ash on the coal and the other at the ash on the bottom layer.

Complete data and the deductions therefrom are given in Table XVII, and the curves plotted from the data in Fig. 17. The tube used was only 2 in. in diameter, since the coal being tested was small, hence a less quantity than the 1200 or 1500 gm. required for a 4-in. tube was permissible.

### Interpretation of the Curves

The shape of the instantaneous ash curve shows immediately that the coal is amenable to cleaning. The ash rises slowly but

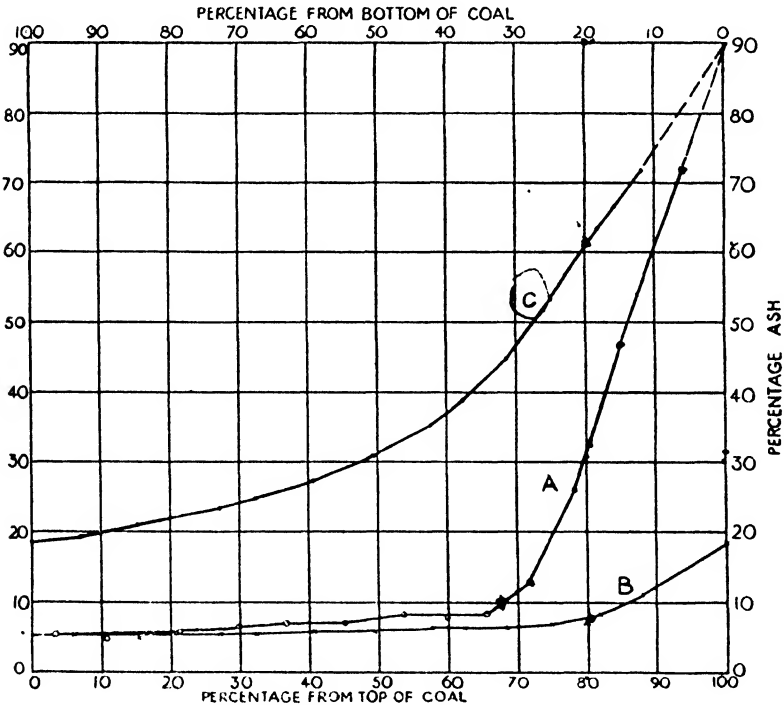

FIG. 17.—Ash Characteristic Curves of a Coal which would be easy to clean. Henry Tube.

- A. Instantaneous Ash of Coal.
- B. Integral Ash of Coal.
- C. Integral Ash of Dirt.

steadily from about 5 to 7.5 per cent. and then suddenly starts to increase rapidly, there being a sharp point of inflection on curve A between 65 and 72 per cent. An integral ash curve of this type is characteristic of a coal which can be easily cleaned.

Inspection of the integral ash curve of the coal shows that it would be possible to obtain a yield of 80 per cent. of clean coal of



## Fuel Testing

ash less than 8.0 per cent., while the integral ash curve of the dirt shows that there would be 20 per cent. of refuse at about 61 per cent. ash. Reference to the instantaneous ash curve shows that the minimum ash on any part of the refuse would be 31 or 32 per cent.

## Float-and-Sink Tests

Separation of the coal is effected by means of liquids or solutions intermediate in specific gravity between the coal and the dirt, the light clean coal being floated away from the heavier dirt. In this test, specific gravity is the only factor influencing the separation; size and shape of particle have no effect, provided sufficient time is allowed for complete separation. Since the moisture in the coal influences the specific gravity, the sample should not be dried before the test is made, or the specific gravity relations of the particles will be altered. Although instructions for carrying out float-and-sink tests sometimes state that the coal should be dried, it is incorrect to do so, since in practice the coal is not dried before being cleaned, and to use completely dried coal in the laboratory is an unwarranted departure from the conditions which it is desired to simulate. How serious the effect of drying before testing may be is shown by the following figures quoted from tests by the Fuel Research Board,<sup>5</sup> in which a sample of coal in the surface-dry and perfectly dry condition was tested on two liquids of specific gravity 1.300, 2 minutes being allowed for separation.

	Zinc Chloride Solution.	Benzene-Carbon Tetrachloride Mixture.
Surface-dry. Per cent. sinks	49.8	46.5
Bone dry            "    "	13.3	14.1

A suitable range of specific gravity for most purposes is from 1.30, by increments of 0.05 to 1.60. Solutions of various inorganic salts in water or mixtures of organic liquids may be used. Solutions of inorganic salts are cheap and easily made, but have the disadvantage that it is often almost impossible completely to free the coal from the inorganic salt, with the result that there is actually an overall increase in ash during the test.

Mixtures of organic liquids have the advantage that their surface tensions and viscosities are lower; on the other hand, they are more expensive. Suitable mixtures may be made of carbon tetrachloride (S.G. 1.595 at 20° C.) with benzene (S.G. 0.878 at 20° C.). If it is desired to use a liquid of higher density, bromoform (S.G. 2.89 at

## Testing Washability of Coal

20° C.) may be employed. Since the boiling-point of bromoform is high (151° C.), samples which have been treated with bromoform or mixtures containing it must be carefully washed; it is a good plan to wash the sample with methylated spirit which dissolves the bromoform, the solution being subsequently poured into water whereby the bromoform is precipitated.

The results obtained with different liquids of the same specific gravity are not necessarily comparable; not only may the cumulative

TABLE XVIII

FLOAT-AND-SINK TEST ON COAL FROM THE GHUSICK SEAM, RANIGANJ  
COALFIELD

108.05 gm. air-dried coal, - 6 +, 30-mesh I.M.M.

Moisture, 3.44 per cent. Equivalent dry coal, 104.2 gm.

Separation by mixed carbon tetrachloride and benzene

S.G. of Liquid.	Weight of Fraction. Gm.	Per Cent. by Weight of Dry Washed Coal.	Cumulative Per Cent. by Weight.	Average Ash on Fraction. Per Cent.	Cumulative Per cent. by Weight to Middle of Fraction.	Integral Ash on Coal. Per Cent.	Cumulative Per Cent. Sinks.	Integral Ash on Sinks. Per Cent.
I	II	III	IV	V	VI	VII	VIII	IX
1.287 float	5.728	5.52	5.52	0.91	2.76	0.91	100.00	12.23
1.314 "	19.910	19.16	24.68	3.17	15.10	2.67	94.48	12.89
1.341 "	16.866	16.22	40.90	8.39	32.79	4.93	75.32	15.36
1.377 "	21.381	20.58	61.48	12.75	51.19	7.55	59.10	17.29
1.423 "	19.860	19.12	80.60	14.67	71.04	9.24	38.52	19.40
1.461 "	10.376	9.43	90.03	21.44	85.32	10.52	19.40	24.67
1.461 sink	9.843	9.97	100.00	27.73	95.01	12.23	9.97	27.73
	103.964	100.00						

Loss on washing, 0.24 gm. or 0.24 per cent.

percentage of ash be altered by absorption or adsorption of inorganic salts, but certain solutions, such as those of zinc chloride, tend to cause disintegration of the coal to a greater extent than would take place in water. In spite of the extra cost, mixtures of organic liquids are preferable to solutions of salts.

Careful standardisation of the conditions of test is essential, otherwise the results will be valueless. In tests with zinc chloride solutions of S.G. 1.300, the percentage yield of sinks with a particular coal varied from 49.8 to 58.3 according as the time of

## Fuel Testing

separation was 2 or 60 minutes and a similar variation was observed with a mixture of benzene with carbon tetrachloride.

To make a specific gravity analysis using heavy liquids, no special apparatus is required. The sample and solution are stirred together in a tall beaker, and after standing for a suitable time to allow separation, the floats are skimmed off with a teaspoon pierced with a number of small holes, transferred to a Buchner funnel, the liquid is sucked off and the solid is dried and weighed. The ash is

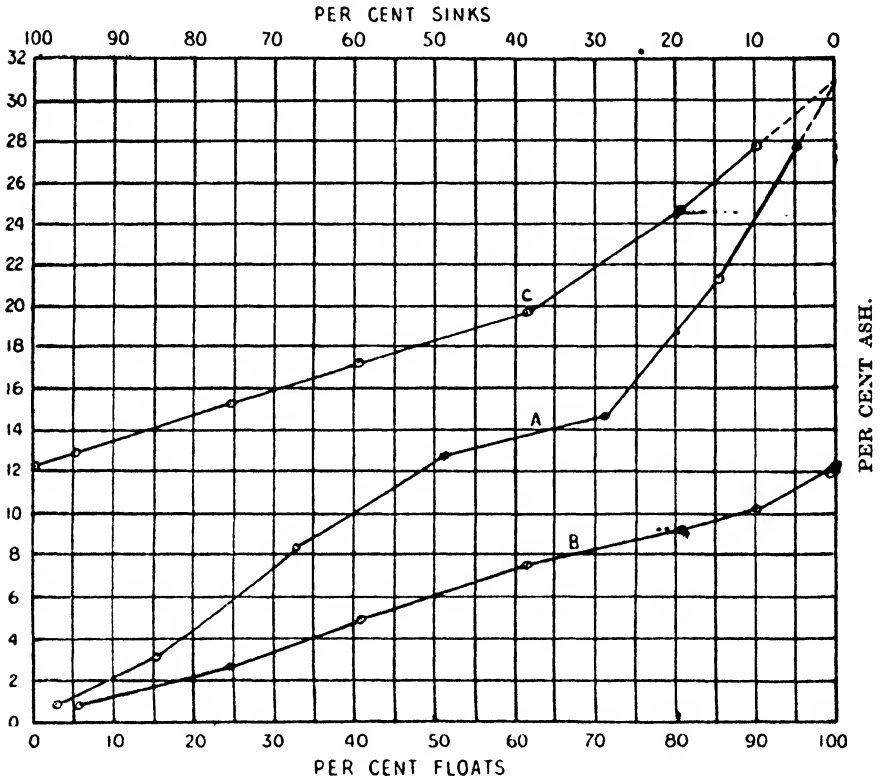

Fig. 18.—Float-and-Sink Test on a Coal which would be difficult to clean.  
Coal Screened — 6 +, 30-Mesh I.M.M. A. Instantaneous ash Curve.  
B. Integral ash in Coal. C. Integral ash on Dirt.

determined on the dried sample as before and the washability curves are constructed.

Table XVIII and Fig. 18 show the results obtained on a sample of Indian coal by E. R. Gee. The instantaneous ash curve shows that this coal would not be amenable to cleaning; there is no definite point of inflection, and the curve slopes upwards more or less uniformly. The integral ash curves on both the coal and the dirt are much flatter than those given by coal No. 4, even though the vertical scale is much more open in Fig. 18.

**Application of Laboratory Tests to Practice**

The results obtained in the laboratory show whether or not a coal may be easily cleaned and also the yields of product which may be expected. By studying the curves it is possible to decide the most economical degree of cleaning, due consideration being given to such factors as enhancement of value and reduction in saleable output. The operation of the coal cleaning plant is conveniently checked by a simplified float-and-sink test. From the original data, a curve is plotted of ash in clean coal versus specific gravity of liquid on which this coal just floats. When samples of clean coal and dirt are brought in for test, it is then only necessary to air-dry them and to make a float-and-sink test on liquid of this gravity. If separation has been complete, there should be no sinks from the clean coal sample and no floats from the dirt. T. J. Drakeley<sup>6</sup> has suggested the following formulæ for calculating the efficiency of a cleaning plant from the results of such a test :

$$\text{Qualitative efficiency} = \frac{100 (\text{washed coal float} - \text{raw coal float})}{100 - \text{raw coal float}}$$

$$\text{Quantitative efficiency} = \frac{100 (\text{raw coal float} - \text{refuse float} \times \text{refuse})}{\text{raw coal float}}$$

Other suggestions are made by H. F. Yancey and T. Fraser,<sup>7</sup> who point out that Drakeley's formula for qualitative efficiency takes no account of the quality of the heavy material remaining in the washed coal. They suggest the formula

$$\frac{\text{Actual yield}}{\text{Standard yield}} \times \frac{\text{Actual reduction in ash}}{\text{Standard reduction in ash}}$$

$$\text{or} = \frac{\text{Yield of washed coal}}{\text{Yield of float coal}} \times \frac{\text{Raw coal ash} - \text{washed coal ash}}{\text{Raw coal ash} - \text{float coal ash}}$$

where "standard yield" and "standard reduction in ash" are taken as the yield of float coal and the reduction in ash obtained by a float-and-sink test of the raw coal which will give the most profitable separation for the coal in question. "Yield of washed coal" refers to the actual yield obtained.

BIBLIOGRAPHY

- <sup>1</sup> J. G. King, M. B. Maries, and H. E. Crossley, *J.S.C.I.*, 1936, **55**, p. 277T.
- <sup>2</sup> F. S. Sinnatt and C. G. Wood, *Trans. Inst. Min. Eng.*, 1923, **66**, pp. 3-4.
- <sup>3</sup> M. W. Blythe and D. O'Shea, *ibid.*, 1919, **57**, p. 261.
- <sup>4</sup> W. R. Chapman and R. A. Mott, "The Cleaning of Coal," 1928.
- <sup>5</sup> Fuel Research Board. Report for Year Ending March 31st, 1930.
- <sup>6</sup> T. J. Drakeley, *Trans. Inst. Min. Eng.*, 1917-18, **54**, pp. 418-59.
- <sup>7</sup> H. F. Yancey and T. Fraser, U.S. Bureau of Mines, Bull. No. 300, 1929, pp. 83-4.

CHAPTER VIII

THE ANALYSIS OF COAL ASH

CONTRIBUTED BY W. C. HANCOCK, B.A., F.I.C.

THE general scheme of the analysis of a coal ash is indicated in the following table :

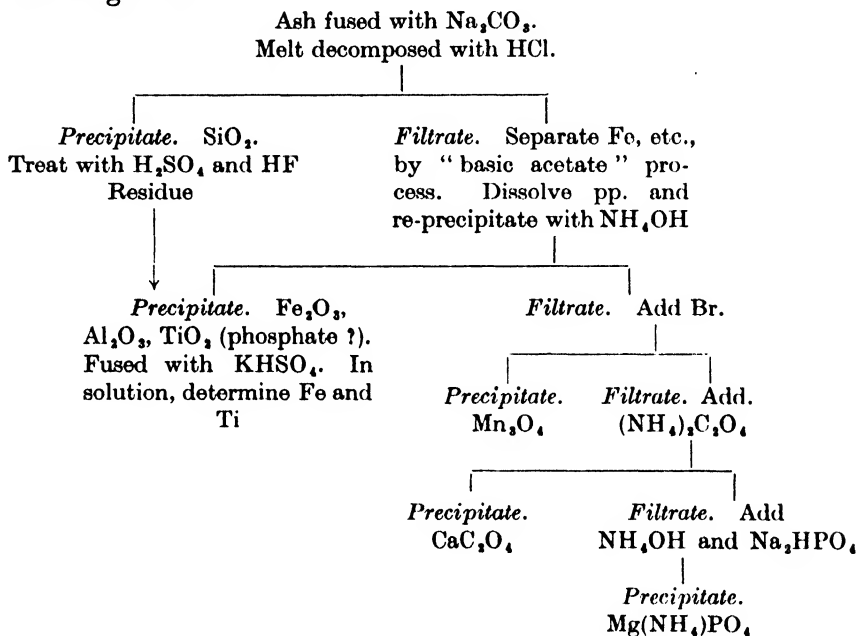

*Separate Determinations.*

1. Alkalies, by Lawrence Smith method.
2. Phosphorus, pp. 67-70.
3. Sulphur, p. 61.

**Opening up the Silicate**

The mineral matter obtained from coal by incineration is usually in the form of a powder sufficiently finely divided for analysis. In some cases, it may be necessary to grind the ash in an agate mortar until no gritty particles are left.

As all fine powders tend to absorb a small amount of moisture if exposed to the atmosphere, it is advisable to heat the samples

## Analysis of Coal Ash

of ash to 105° C. to remove this "hygroscopic water" and to keep the dried material in a stoppered weighing bottle.

An accurately weighed quantity (about 1 gm.) of the dried powder is intimately mixed with about 4 gm. of pure anhydrous sodium carbonate in a platinum crucible, provided with a lid. The crucible and its contents are heated, at first gently, over a Bunsen burner and afterwards the heat is increased until complete fusion has occurred. This can often be effected with a good Bunsen burner, but sometimes a Méker burner or a blow-pipe is required; in any case the mass should be maintained in a quiet molten condition for a few minutes. The melt quickly solidifies on cooling, and it is useful to spread it in a thin layer on the wall by imparting a circular motion to the crucible, as this facilitates the solution and removal of the melt.

### Silica

The melt is treated with hot water and transferred as completely as possible to a deep porcelain (or platinum) basin of about 300 ml. capacity. The crucible is cleaned finally with hydrochloric acid which is poured on to the liquid and suspended solid in the basin, which must be covered with a clock-glass to prevent any loss through the brisk effervescence caused by the decomposition of the carbonates. When the contents of the basin have been rendered distinctly acid with hydrochloric acid, the basin is heated for a few minutes on a water-bath (or over a very low flame) until all the dissolved carbon dioxide has been expelled from the solution. The under side of the clock-glass is then washed down with water and the contents of the basin are evaporated to complete dryness on a water-bath and the heating continued until the residue retains no appreciable smell of acid while still warm. The expulsion of the acid may be hastened by gently grinding the mass with a blunt-ended rod. The residue is then treated with a few ml. of water and hydrochloric acid and again evaporated to complete dryness.

The mass is taken up with water and hydrochloric acid and may be warmed on a bath, as this facilitates the filtration. The silica in suspension is filtered off (a 9 cm. No. 40 Whatman paper being very suitable for the purpose) and washed free from salts. Freedom from chloride can be ascertained by adding silver nitrate solution to a few drops of the filtrate, or by evaporating about 20 drops of it to dryness in a watch-glass on a water-bath, when no perceptible residue should be left.

The filter paper containing the separated silica is transferred to a weighed platinum crucible and heated gently at first and then over a blow-pipe until constant in weight. The weight thus obtained is

## Fuel Testing

often described as "impure silica" since it invariably contains traces of other constituents of the ash. It is a very light powder and whenever it is re-heated, should be warmed gently at first or otherwise the rapid expansion of the occluded air may carry off a little cloud of the powder. The impure silica is moistened with a little dilute sulphuric acid and sufficient hydrofluoric acid is added to convert the silicon into the tetrafluoride. The object of adding the sulphuric acid is to convert, into non-volatile sulphates, any fluorides of the bases which may be formed at first, some of which, e.g. aluminium fluoride, are volatile. The crucible containing the liquid is heated on a sand-bath, in a fume cupboard, till a dry residue is left and then heated strongly over a Méker burner. The weight of this residue is deducted from that of the "impure silica" and the result gives the "true silica." The residue, which is usually very small, may be fused with potassium bisulphate, dissolved in water, acidulated with sulphuric acid, and added to the filtrate from the silica, or it may be left in the crucible which can afterwards be used for the ignition of the mixed oxides of iron, aluminium, etc.

## Iron, Aluminium and Titanium

The treatment of the filtrate from the silica depends upon whether manganese, which is very frequently present, is to be determined. *If manganese is to be determined*, the iron, aluminium, etc., should be separated by the basic acetate process. The liquid may be boiled with a few drops of nitric acid, cooled, and nearly neutralised with solid ammonium carbonate, "but no permanent precipitate must be formed" (Fresenius). If much iron is present the liquid acquires a deep red colour. About 20 ml. of a 20 per cent. solution of ammonium acetate are added and the liquid is heated and maintained at the boil for about 2 minutes. On standing, the precipitate should settle quickly and the clear liquid is decanted through a loose-textured filter paper (e.g. No. 41 Whatman) and the precipitate washed quickly with water containing some ammonium acetate. As soon as all the precipitate has been transferred to the paper, it is dissolved in acid (hydrochloric is generally used) and reprecipitated with ammonia. The precipitate is filtered off and washed, the filtrate and washings being added to the filtrate from the basic acetate precipitation. The precipitate is ignited in the platinum crucible, containing the residue from the impure silica and is strongly heated over the blow-pipe to constant weight. The weight thus obtained gives the total amount of iron, aluminium and titanium oxides, which can be brought into solution by fusing with potassium bisulphate and dissolving the melt in water containing some sulphuric acid, the solution being made up finally to a known volume, in aliquot portions of which the iron and titanium are determined.

### Iron

The iron is usually determined by reduction and titration. The reduction can be brought about by zinc and the solution titrated with standard potassium dichromate in the ordinary way, but this process is liable to a slight error, due to the fact that titanium oxide is also reduced and the value obtained for the iron is therefore high. A more accurate method is to reduce the iron by passing sulphuretted hydrogen gas, boiling off the excess in an atmosphere of carbon dioxide until the issuing vapour no longer darkens a mercuric chloride paper, and titrating with standard potassium permanganate solution.

### Titanium

The titanium is determined colorimetrically by comparison with a standard titanium solution. This solution can be prepared conveniently by fusing 0.1 gm. of pure titanium oxide with potassium bisulphate, dissolving the melt in water containing about 10 per cent. of sulphuric acid, and making up to 100 ml. As the colour developed in such a solution is too deep to allow of accurate matching, it is advisable to take 1 ml. of the solution, add sufficient hydrogen peroxide to develop the yellow colour and make up to 100 ml.; 1 ml. of this diluted standard contains 0.041 gm. of titanium oxide. To a small portion of the solution containing all the iron, aluminium and titanium as sulphates, say, about 5 ml. out of a total of 250 ml. hydrogen peroxide is added, the mixture being contained in a Nessler glass and the diluted titanium solution is run from a burette into another similar Nessler glass until the two colours match. The number of ml. used, multiplied by 0.00001, gives the weight of titanium oxide in the 5 ml. taken.

### Aluminium

The amount of alumina is obtained by deducting from the total weight of the mixed oxides the weights of ferric and titanic oxides already found.

*If the determination of manganese is unimportant*, the hydroxides of iron, aluminium, etc., may be precipitated from the filtrate from the silica by adding ammonia direct. Instead of igniting this precipitate, it is sufficiently accurate for most technical analyses to dissolve it in hot dilute sulphuric acid. As the paper used for filtering off the precipitate, however, invariably retains traces of iron, etc., after dissolving the precipitate, the paper should be ignited in the crucible containing the residue from the "impure silica"; the residue and filter ash are then fused with potassium bisulphate and the melt dissolved in the liquid containing the bulk of the iron, etc.



## Fuel Testing

This solution is made up to, say, 250 ml., an aliquot portion withdrawn, e.g. 50 ml., precipitated with ammonia, filtered, washed, ignited and weighed; this weight multiplied by 5 gives the total weight of the mixed oxides and the iron and titanium can be determined in separate portions of the 250 ml. by the methods described above.

## Manganese

The filtrate from the basic acetate precipitation and from the re-precipitation of the hydroxides by ammonia, is concentrated and bromine added till the liquid retains a definite orange colour. The solution is then made distinctly ammoniacal and boiled; any manganese present is precipitated and is filtered off, washed, ignited and weighed as  $Mn_3O_4$  ( $Mn_3O_4$  multiplied by  $\cdot 91 = MnO$ ).

## Calcium and Magnesium

The filtrate from the manganese is boiled, the calcium precipitated with ammonium oxalate and determined as  $CaO$ . The magnesium is precipitated from the filtrate, after it has been rendered distinctly ammoniacal, with a solution of hydric di-sodic phosphate in the usual way and ignited and weighed as magnesium pyrophosphate ( $Mg_2P_2O_7$ , multiplied by  $\cdot 36 = MgO$ ).

## ALTERNATIVE METHOD FOR THE SEPARATION OF IRON, ALUMINIUM AND TITANIUM <sup>2, 3</sup>

If the percentage of phosphorus in the ash is high, the iron, titanium and aluminium should be determined separately, since otherwise the mixed hydroxides will be contaminated with phosphates with consequent inaccuracy in the gravimetric determination of the mixed oxides. During the separation, all operations involving the use of ammoniacal solutions should be carried out as quickly as possible; this avoids the contamination of precipitates with calcium carbonate, caused by the solution of atmospheric carbon dioxide.

*Reduction of Manganates.*—This is necessary as a preliminary, since the presence of manganates in solution may lead to incomplete precipitation of manganese at a later stage. Two methods are suggested:

(i) The cold acid filtrate from the determination of silica is reduced by means of sulphur dioxide gas or by pure sodium sulphite. The reduced solution is boiled until the excess of sulphur dioxide is expelled, cooled, and the cold solution is oxidised by the addition of a slight excess of bromine water; the temperature is then raised to the boiling-point and maintained until the excess of bromine is expelled.

## Analysis of Coal Ash

(ii) The cold, acid filtrate from the determination of silica is treated with a slight excess of hydrogen peroxide *which is free from phosphoric acid*, the temperature is raised to boiling and maintained for 5 minutes.

To the reduced solution obtained by either process, 5 ml. of ammonium chloride solution are added (100 gm.  $\text{NH}_4\text{Cl}$  per litre), and after cooling to a few degrees below the boiling-point a *slight* excess of ammonia solution (made up of equal volumes of 0.88 ammonium hydroxide and water), with brisk stirring. The insoluble hydroxides are allowed to settle in the cold and transferred to a filter; when as much as possible of the precipitate has been removed from the sides of the beaker, any remaining particles are dissolved in about 2 ml. of dilute hydrochloric acid (1 volume concentrated  $\text{HCl}$  diluted with 9 volumes water), reprecipitated with ammonia and transferred to the filter. The mixed hydroxides are then washed with cold ammonium nitrate solution (50 gm. per litre). In carrying out the precipitation, it is necessary to control carefully the alkalinity of the solution; precipitation of aluminium hydroxide is complete when the  $\text{pH}$  value lies between 6.5 and 7.5, which is approximately defined by the change of colour of methyl orange to pale yellow.

The combined filtrate and washings are used for the determination of manganese, lime and magnesia. The precipitate is dissolved by a boiling solution of dilute sulphuric acid (2N), the paper is washed with boiling water and macerated with dilute boiling sulphuric acid, and the acid extract is filtered into the solution of the precipitate. The process of precipitation and solution is repeated, the filtrate from the second precipitation being added to that from the first. The double precipitation is carried out (a) to prevent the inclusion of a small amount of manganese with the insoluble hydroxides, and (b) to free the final solution in sulphuric acid from alkali salts which might be occluded during the subsequent precipitation.

The purified solution of iron, aluminium and titanium in sulphuric acid is diluted to 250 ml., 100 ml. are withdrawn and the hydroxides are precipitated by means of ammonia; the precipitate is filtered off, washed and ignited as usual, giving the  $\text{Fe}_2\text{O}_3$ ,  $\text{Al}_2\text{O}_3$ ,  $\text{TiO}_2$  and  $\text{P}_2\text{O}_5$ .

*Separation of Iron.*—To a second portion of 100 ml. of the solution contained in a 250 ml. conical flask, 3 gm. of solid tartaric acid, a slight excess of dilute ammonia and a slight excess of dilute sulphuric acid are added. The iron is completely reduced to the ferrous state by a fairly rapid stream of hydrogen sulphide during about 30 minutes. The hydrogen sulphide should be washed with water to remove spray which might be contaminated with iron.

## Fuel Testing

Concentrated ammonia is then added drop by drop, passage of hydrogen sulphide being continued, until a black precipitate just forms. An excess of about 3 ml. of ammonia (1 volume 0.88 ammonia with 1 volume of water) is added and hydrogen sulphide is passed for a further 5 minutes. The delivery tube is washed into the liquid, the flask is corked and allowed to stand until the precipitate has settled. The liquid is passed through a Hirsch filter funnel and the precipitate transferred thereto. The precipitate is washed with cold dilute ammonium chloride solution to which a little ammonium sulphide solution has been added and the combined filtrate and washings are reserved. Filtration should be assisted by suction to hasten the process and to avoid undue oxidation of ferrous sulphide. The precipitate is dissolved in hot dilute sulphuric acid, a slight insoluble residue of sulphur being left. The filtrate from the separation is treated with a slight excess of dilute sulphuric acid and the process of reduction, precipitation, settling, filtration and washing are repeated to precipitate the last traces of iron from the alumina and titania. Any precipitate so obtained is dissolved as before and added to the previous solution of iron. The solution is evaporated until fumes of sulphuric acid are evolved, cooled and diluted with 100 ml. of water. Iron is determined in this solution either by reduction to ferrous sulphate and subsequent titration with permanganate or dichromate or by means of titanous sulphate. The combined filtrates are reserved for the determination of titanium and aluminium.

*Separation of Titanium.*—The combined filtrates from the precipitation of ferrous sulphide are acidified with a considerable excess of dilute sulphuric acid (approx. 2N) and boiled until all hydrogen sulphide is expelled. Any precipitate of sulphur is filtered off, the filtrate is partially neutralised with dilute ammonia until the solution is only slightly acid; the solution is then cooled to a temperature not exceeding 10° C., and the titanium is precipitated by addition of an excess of “cupferron” solution, also at a temperature not exceeding 10° C. During the addition, the solution should be cooled in ice-water.

The solution of “cupferron” (the ammonium salt of nitroso-phenylhydroxylamine,  $C_6H_5N \cdot NO \cdot ONH_4$ ) is prepared *immediately before use* by dissolving 6 gm. cupferron in 100 ml. water. The precipitant is added slowly, with agitation of the solution, until an excess is indicated by a temporary flash of a fine, white precipitate which redissolves, as contrasted with the flocculent and insoluble cupferron precipitate. About 5 ml. of the cupferron reagent is usually an excess. The liquid is then allowed to stand for 10 minutes, filtered with gentle suction and the precipitate is washed with 2N sulphuric acid containing 1.5 gm. cupferron per litre. When drained,

## Separate Determinations

the precipitate is transferred to a crucible, dried cautiously and ignited. The residue is taken as  $TiO_2$ .

*Note.*—In carrying out the determination, the temperature conditions must be observed, while suction filtration is necessary for thorough washing.

Care must be taken when drying and igniting the precipitate, since it tends to liquefy and effervesce.

*Aluminium.*—May be directly determined in the filtrate from the cupferron precipitation. The filtrate is treated with 5 ml. of concentrated sulphuric acid and evaporated to about 20 ml. 20 ml. of concentrated nitric acid are added and the evaporation is continued until fumes of sulphuric acid are evolved. The treatment with nitric acid is repeated and evaporation is continued until no further organic matter remains. The residual liquid is carefully washed into 100 ml. of water, 10 ml. of 10 per cent. ammonium chloride solution are added and the aluminium is precipitated as hydroxide by the addition of a slight excess of ammonia. The precipitate is filtered off, washed with cold dilute ammonium chloride solution (2 per cent.), ignited and weighed. If the  $P_2O_5$  in the ash exceeds 0.05 per cent., a correction may be applied by deducting the percentage of  $P_2O_5$  from the percentage of alumina found above.

## SEPARATE DETERMINATIONS

### 1. Alkalies

The most generally applicable method for the determination of alkalies in silicates is that of Dr. J. Lawrence Smith.<sup>1</sup> The description, in Dr. Smith's own words, is reproduced in Crookes' "Select Methods in Chemical Analysis," and is well worth careful study.

The following is a brief description of the method: Weigh out about 0.25 to 0.5 gm. of the finely powdered ash, approximately an equal weight of ammonium chloride, and eight times the weight of calcium carbonate. The ash and ammonium chloride are first ground together in a large agate or porcelain mortar and thoroughly mixed with about three-quarters of the calcium carbonate, added in small portions at a time. The mixture is then introduced into a platinum crucible, the bottom of which may be covered with a thin layer of the carbonate, the remainder of which is used to "rinse" out the mortar and is added to the mixture in the crucible, which is gently tamped down. The crucible, provided with a tight-fitting lid, is then heated, and can be supported conveniently in a hole in an asbestos board, to prevent any sulphur fumes from the burner combining with the mixture. The crucible is heated very gradually at first for about 20 to 30 minutes, during which time the ammonium salt is slowly volatilised. The heat is then increased until the lower

## Fuel Testing

third of the crucible is at a dull red heat and is maintained thus for about 15 minutes. The mixture contracts considerably and gives a "sintered" but not a "fused" mass. When cold the mass can, as a rule, be detached easily from the crucible and is dropped into a porcelain basin and covered with about 150 ml. of hot water. When the mass has disintegrated, the liquid, which contains the alkalies, is poured through a filter paper, and any lumps in the residue are crushed and washed on to the filter with hot water. When the filtrate amounts to about 400 ml., sufficient solid ammonium carbonate is added to precipitate the calcium salts in the solution, which is then evaporated to dryness. The residue is taken up with a solution of ammonia and ammonium carbonate, to remove the last traces of calcium, filtered and the filtrate and washings (which must be carried out with a solution of ammonia and ammonium carbonate of the same strength) evaporated to dryness in a weighed platinum dish. This residue is heated over a very low flame until all the ammonium salts have been volatilised. The residue, composed of the chlorides of the alkalies, is heated to a temperature just below redness and weighed till constant. This may be done conveniently by waving a Bunsen flame under the dish which is carried with tongs to the balance, but is not placed on the pan until the dish feels only very slightly warm to the touch. At first the weight will appear to decrease as the dish cools, then remain constant for a short time and then increase as the chlorides absorb water. The heating and weighing should be repeated to ensure that the weight of the mixed chlorides is constant.

The mixed chlorides of sodium and potassium can be separated by the perchloric acid method. The mixed salts are dissolved in a few ml. of water, and about three times as much perchloric acid added as is required to convert the chlorides into perchlorates. The liquid is evaporated until fumes of perchloric acid appear. About 6 ml. of perchloric acid are added and the evaporation repeated till white fumes again appear (in order to remove hydrochloric acid completely). Alcohol of specific gravity about 0.8 (corresponding to 96 to 97 per cent. of absolute alcohol by weight) is added and the precipitated potassium perchlorate filtered off on to a Gooch crucible or Soxhlet tube by suction with a water-pump, and washed with alcohol of the same strength, containing 0.2 per cent. by weight of perchloric acid. The crucible (or tube) and precipitate are dried at 120° C. and weighed. The weights of potassium and sodium oxides can be calculated from the following data :

Weight of  $\text{KClO}_4$  multiplied by 0.5381 =  $\text{KCl}$   
" " " " " 0.34 =  $\text{K}_2\text{O}$   
" " mixed chlorides— $\text{KCl} = \text{NaCl}$   
" "  $\text{NaCl}$  multiplied by 0.5303 =  $\text{Na}_2\text{O}$

## Separate Determinations

*Note.*—The methods suggested by the British Standards Institution <sup>2</sup> and Fuel Research Board <sup>3</sup> are somewhat different from those given above. For details, the references should be consulted.

Although the total of the percentages of oxides determined in an ordinary analysis of coal ash is generally near 100, oxides of other less common elements are frequently present, including those of: Li, Rb, Cs, Cu, Ag, Au, Sr, Ba, Zn, Ge, In, Th, B, Va, As, Sb, Bi, Cr, Mo, Ni. Determinations of these oxides are seldom undertaken. The presence of small quantities of such abnormal constituents may, however, have an industrial significance. Thus, G. T. Morgan and G. R. Davies <sup>4</sup> showed that the ashes from practically all British coals contain small quantities of oxides of germanium and gallium, and that these oxides are concentrated in the flue-dust when the coals are burned. They suggested that by slight modification of the conditions of burning the coals, the oxides might be rendered commercially recoverable and prove a valuable source of supply.

## BIBLIOGRAPHY

- R. Fresenius, "Quantitative Chemical Analysis."  
W. Crookes, "Select Methods in Chemical Analysis," 1905.  
J. W. Mellor, "Quantitative Inorganic Analysis."  
Washington, "Chemical Analysis of Rocks."  
W. F. Hillebrand, "The Analysis of Silicate and Carbonate Rocks."  
<sup>1</sup> J. Lawrence Smith, *Amer. Journ. Sci.*, 2nd ser., 1871, **50**, p. 269.  
<sup>2</sup> British Standard Specification No. 1016, 1942.  
<sup>3</sup> Fuel Research Board, Survey Paper No. 28, 1933.  
<sup>4</sup> G. T. Morgan and G. R. Davies, *Chem. and Ind.*, 1937, **15**, pp. 717-721.

## CHAPTER IX

### THE FUSION POINT OF COAL ASH

MINERAL matter in coal may be objectionable not only by reason of its amount, but even more so on account of its properties. It is sometimes necessary to reject a low-ash coal which is otherwise suitable for a particular purpose on account of the easy fusibility of the ash, and to substitute for it a coal carrying a higher proportion of mineral matter which leaves in the furnace a residue which shows little or no clinkering propensity. A low-melting ash gives rise to trouble and loss in various ways.

(i) Combustible matter becomes enclosed in fused masses of slag and is thus wasted.

(ii) The air-passages of the grate are choked by clinker which must be dislodged by poking and slicing, causing further loss of combustible which riddles through the grate into the ashpit. At the same time, extra slicing and poking of the fire almost inevitably drive small pieces of clinker up into the hottest zone where they form centres on which large masses of clinker subsequently grow.

(iii) The supply of air to the furnace is interfered with and stack losses are increased because extra draught is required to maintain the necessary rate of combustion.

(iv) Clinker fuses to the refractories in the furnace and mechanical damage is done when removing it.

(v) The ash may attack the refractory materials of the furnace, causing them to slag down.

A laboratory test is therefore required to enable the clinkering propensities of coal ash to be predicted.

Generally speaking, there is a parallelism between the fusion point of a coal ash and its tendency to form clinker in a furnace: the term "parallelism" has been used advisedly, since conditions in the furnace are by no means reproduced in laboratory tests, and two ashes showing the same fusion point may have distinctly different clinkering propensities. The correlation of laboratory tests with the clinkering propensity of coal ash is difficult, since, in the laboratory, a small sample of finely ground and intimately mixed ash is employed, whereas in the plant, the mineral matter is unevenly distributed through the coal, consequently the conditions are very different.

## Fusion Point of Coal Ash

The ultimate analysis of the ash at the best gives little information as to the nature of the parent mineral matter, and it is therefore difficult to connect the chemical composition with the melting-point. Generally, the more closely the composition approximates to  $\text{Al}_2\text{O}_3 \cdot 2\text{SiO}_2$ , and the lower the content of iron and alkalies, the more refractory the ash will be, although this is not always true.

If clinker is to be formed, not only must the temperature be sufficiently high to fuse the ash, but also the viscosity of the resulting slag must be low enough to permit it to flow. A very fluid slag may flow readily and form clinkers which contain a considerable proportion of unmelted solid; on the other hand, an ash consisting solely of alumina and silica might be completely melted and, on account of the high viscosity of the slag, would not flow readily.

The information which is required is at what temperature the ash may form a slag sufficiently fluid to flow or to agglomerate in the fuel bed. This temperature is usually below that of complete fusion owing to the formation of eutectics. The simplest method to determine the temperature at which the melting ash forms a slag of standard viscosity is the softening-point test, and this is carried out by noting the temperature at which a small pyramid of the ash collapses to a blob.

A cone of silicate materials which are capable of forming eutectics starts to weaken as soon as the eutectic begins to melt, and the progress of deformation will be governed by the relative proportion of eutectic present and its fluidity. If there be a large proportion of a very fluid eutectic, the deformation and melting-points will approximate closely, while a large excess of some refractory constituent may form a rigid skeleton which is not distorted by the melting of the eutectic and the deformation point will be near the melting-point of the refractory component.

The phenomena of softening and fusion of coal ash involve chemical action, melting and solution in which the factors of time and fineness of division of the constituents are of the greatest importance. Reactions between certain constituents of the ash and between certain oxides and the atmosphere in the furnace take place prior to melting. Constituents such as silica and felspar have a low rate of melting, and may be heated for some time above their fusion points and still remain crystalline.

The influence of oxides of iron is important, especially in relation to the atmosphere in the furnace. Ferric oxide forms compounds with silica which require a high temperature for their fusion; in an oxidising atmosphere, in the absence of reducing gases, iron reacts as ferric oxide or as a solid solution varying from ferric to magnetic oxide of iron. Slags thus formed are more refractory and viscous



## Fuel Testing

than those formed by heating mixtures of iron oxide and silica in atmospheres favouring the formation of FeO.

A. C. Fieldner and W. A. Selvig<sup>1</sup> described experiments on the fusion of five coal ashes containing from 7 to 70 per cent. of ferric oxide in atmospheres of steam and hydrogen in various proportions. For each ash there was a high softening temperature in hydrogen owing to reduction of iron oxide to metallic iron; a similar high softening point was noted in an atmosphere of water vapour, when the iron oxide was for the most part maintained in the form of ferric oxide or magnetite. In atmospheres containing from 30 to 70 per cent. of hydrogen, which caused the reduction of most of the iron oxide to the ferrous state, the softening temperature was lower. In one series of tests the results given in Table XIX were obtained:

TABLE XIX

EFFECT OF COMPOSITION OF ATMOSPHERE ON THE SOFTENING TEMPERATURE OF A COAL ASH

Composition of Ash.	Per Cent.	Hydrogen in the Gases. Per Cent.	Softening Point. °C.
SiO <sub>2</sub> . . . . .	37.2	100	1370
Al <sub>2</sub> O <sub>3</sub> and P <sub>2</sub> O <sub>5</sub> . . . . .	25.5	93	1270
Fe <sub>2</sub> O <sub>3</sub> . . . . .	11.8	80	1200
TiO <sub>2</sub> . . . . .	1.5	58.5	1065
CaO . . . . .	12.6	49	1075
MgO . . . . .	1.9	22.5	1095
Na <sub>2</sub> O . . . . .	1.4	16	1095
K <sub>2</sub> O . . . . .	0.4	5	1080
SO <sub>2</sub> . . . . .	5.6	0	1300

The other ashes showed similar though less pronounced effects.

In various mixtures of carbon monoxide and carbon dioxide it was found that in order to obtain consistent results, slower heating was necessary. The minimum softening point was obtained between approximate limits of 75 and 10 per cent. of carbon monoxide, and was rather higher than with the hydrogen/steam atmospheres.

The sharp rise of the softening point curves at the ends shows that no concordant results can be expected in oxidising atmospheres which contain small proportions of reducing gases, or in reducing atmospheres with small admixtures of oxidising gases, hence it is important that in carrying out the softening point tests in the laboratory the composition of the atmosphere in the furnace be kept under control so that the iron compounds in the ash are reduced to the ferrous state in which they can exert the maximum fluxing action. This is the more necessary, since analyses of

## Fusion Point of Coal Ash

clinkers from furnaces have shown that most, if not all, of the iron is in the ferrous condition. *The mere statement of the softening temperature of a coal ash without any indication of the atmosphere in which the test was carried out is valueless and may be misleading.*

### The Determination of the Fusion Point of Coal Ash

The method is described by the Fuel Research Board<sup>3</sup> and the British Standards Institution,<sup>4</sup> and entails determinations in both reducing and oxidising atmospheres. The temperatures to be determined are defined as follows:

(i) *Initial Deformation Temperature or Softening Point.*—The temperature at which the first signs of rounding of the edges or tip of the test-piece occur.

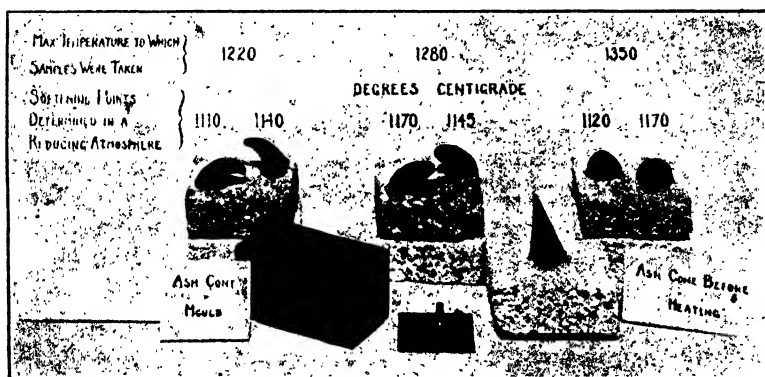

FIG. 19.—Mould for Preparation of Ash Cones, and Examples of Fresh and Fused Cones.

(Reproduced from Fuel Research Technical Paper No. 23, by permission of the Controller of H.M. Stationery Office.)

(ii) *Fusion Temperature.*—The temperature at which the ash completely fuses to a blob.

In addition, the *Fusion Range* is the interval between the softening point and the fusion temperature.

### Preparation of the Ash Cones

The ash is ground in an agate mortar to an almost impalpable powder, approximately 240-mesh B.S. sieve (= 200 I.M.M.), moistened with a 10 per cent. solution of dextrin in water until a paste is formed, and moulded into a cone in a brass mould, as shown in Fig. 19. The mould is previously coated with a thin layer of vaseline to prevent the ash from adhering to the metal. The cones are triangular pyramids with one side perpendicular to the base, measuring 1 in. in height and  $\frac{1}{2}$  in. along the side of the base. The moist

## Fuel Testing

cone is allowed to dry in the air and is then mounted on a base of refractory brick. To oxidise any carbonaceous matter and to remove the carbon produced from the dextrin, the cone is either heated for some time in an open muffle at from 800° to 900° C., or in the furnace with the slide open, so that a current of air passes over it. A. C. Fieldner, A. E. Hall and A. L. Feild,<sup>2</sup> as a result of numerous experiments, recommended the use of cones which soften a lump without bending; this condition is usually fulfilled by cones of the dimensions given above.

## Method of Determination

The cone is placed in a suitable furnace which has been previously heated to about 800° C., and the temperature is raised to about 1000° C. in one hour. The rate of heating is then controlled so as to be from 3° to 4° C. per minute when a reducing atmosphere is used, or 5° when an oxidising atmosphere is used. When the stage of initial deformation is reached, the rate of rise of temperature in a reducing atmosphere should be reduced to about 2° per minute for from 20 to 30 minutes to allow the reducing reactions to be completed. Should complete fusion not take place during this period, the rate of rise of temperature may be again increased to 3° to 4° per minute.

The composition of the reducing atmosphere should be such that the ratio of reducing to oxidising gases is approximately  $\frac{40}{60}$ , and may generally be safely varied between  $\frac{20}{80}$  and  $\frac{80}{20}$ . "Reducing" gases include hydrogen, hydrocarbons and carbon monoxide, while oxygen, carbon dioxide and water vapour are considered to be "oxidising" gases. A reducing atmosphere is most conveniently provided by mixing partially burned coal-gas with a small quantity of fresh gas. Alternatively, a stream of hydrogen may be bubbled through water heated to a temperature such that the hydrogen carries with it the correct quantity of water vapour to give the desired ratio of reducing to oxidising gases; regulated streams of hydrogen and carbon dioxide from cylinders in the correct proportions may also be used.

The temperature of the specimen is measured by means of an optical pyrometer, preferably of the disappearing-filament type. It is necessary to make a small correction for the absorbing effect of the window in the sighting hole when a reducing atmosphere is employed; this effect is of the order of from 10° to 15° C., and the values of the correction may be determined at different temperatures by taking readings of the pyrometer with and without the window when an oxidising atmosphere exists within the furnace. The effect of a slight haze produced by combustion at the end of the sighting tube has been shown to be negligible.

## Fusion Point of Coal Ash

Observations should be made and logged somewhat as follows :

Ash from : Coal A.		Date : 9/5/30. Pyrometer No. 60,229. Furnace : Brayshaw. Atmosphere : Reducing.
Time.	Temperature °C.	Observations.
2.0	—	Start.
2.50	1000	No change.
	1050	" "
	1070	" "
3.15	1100	" "
	1125	Blistering at base.
	1140	No change.
3.30	1155	Tip rounded.
3.35	1165	Appreciably rounded.
3.39	1175	Cone beginning to squat.
3.44	1185	Squatting.
3.51	1200	Squatting and beginning to blister.
3.59	1215	Very little change.
4.6	1230	Squatting and blistering.
4.9	1240	Blobbing and blistering.
4.12	1250	Blobbing complete, still blistered.
Colour of ash :		
(a) as incinerated . . . .		Cream.
(b) after grinding . . . .		Buff with slight pink tinge.
Colour of paste . . . .		Light fawn.
Appearance of residue after being heated . . . .		Brownish-black. Rough blistered surface without glaze. Not slagged with insulating tile.

**The Furnace** must comply with the following conditions :

(i) It must provide a zone of uniform temperature in which to heat the cone ; (ii) adequate means of ensuring a suitable rate of rise in temperature must be provided ; (iii) it must be possible to maintain within the furnace an atmosphere round the cone of any desired composition ; and (iv) means must be provided for observing the cone during heating.

The furnace illustrated in Fig. 20 was designed by the Fuel Research Board in association with Messrs. Brayshaw of Manchester, to operate on a low-pressure air supply. It operates successfully up to 1500° C. with pressures of 6 in. of water, such as can be supplied

## Fuel Testing

by a small fan blower. The attainment of this temperature easily is rendered possible by heating the air required for combustion in a

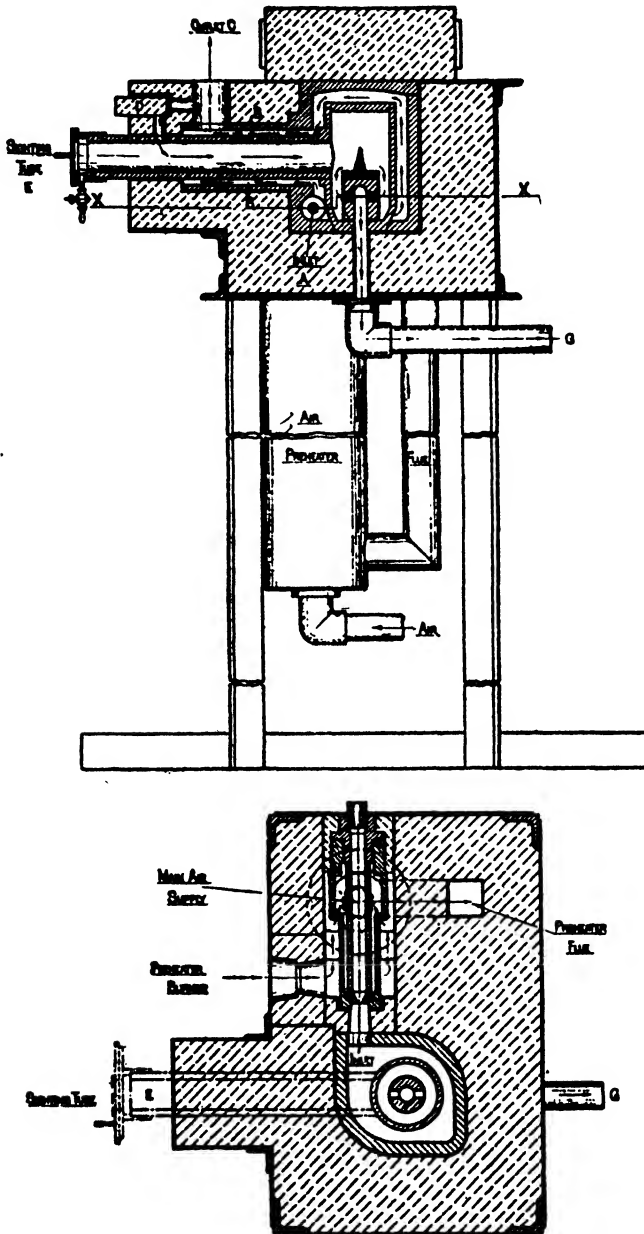

FIG. 20.—Gas Heated Vertical Muffle Furnace for Testing Coal Ash.  
(By courtesy of the Colliery Guardian Co., Ltd.)

preheater shown below the furnace proper, and which is heated by a separate burner. The hot air from the preheater circulates round

## Fusion Point of Coal Ash

the main burner and enters the main gas stream at the point where combustion takes place and the hot gases circulate round the crucible. To produce a reducing atmosphere within the crucible, the top waste gas vent is partly closed and the damper opened so as to allow the partly burned gases to enter the sighting tube and so reach the inside of the crucible. The gases then leave the crucible through holes in the stand supporting the cone of ash, and so out at the back of the furnace. To obtain an oxidising atmosphere, the window of the sighting tube is opened, the damper is closed and the upper vent is fully opened. The conditions are then adjusted to admit excess of air, and complete combustion takes place inside the furnace. The softening of the cones and the temperature are observed through the sighting tube with an optical pyrometer. Under normal reducing and oxidising conditions when using a coal gas of 490 B.Th.U.s. per cu. ft., the approximate quantities of gas and air used for operating at 1400° C. are :

Condition.	Gas, cu. ft.	Air, cu. ft.	Air Pressure. In. Water.
	Per Hour.		
Reducing . . .	120	390	2.2
Oxidising . . .	73	515	5.0

The proportion of the gas used in the preheater is about 17 per cent. for a reducing atmosphere and 27 per cent. for an oxidising one. The total gas consumption for a single determination is about 160 cu. ft. for a reducing atmosphere to a temperature of about 1300° C., and 80 cu. ft. for a determination in an oxidising atmosphere up to about 1400° C.

J. Hiles and J. K. Thompson<sup>5</sup> have described an electrically-heated tube-furnace which is suitable for determining the fusion temperature of coal ash; they have also shown that with this furnace, the measurement of temperature may be carried out by means of a thermo-junction.

### BIBLIOGRAPHY

<sup>1</sup> A. C. Fieldner and W. A. Selvig, *Trans. Am. Inst. Min. and Met. Eng.*, 1926, **74**, pp. 457-71.

<sup>2</sup> A. C. Fieldner, A. E. Hall, and A. L. Feild, U.S. Bureau of Mines, Bull. No. 129, 1918. Also A. C. Fieldner and W. A. Selvig, *Fuel in Science and Practice*, 1926, **5**, pp. 24-33.

<sup>3</sup> Fuel Research Board, Technical Paper No. 23, 1929.

<sup>4</sup> British Standard Specification No. 1016, 1942.

<sup>5</sup> J. Hiles and J. K. Thompson, *Fuel*, 1941, **20**, pp. 135-37.

## CHAPTER X

### GAS ANALYSIS

THE problems in gas analysis which confront the fuel technologist are, broadly : (1) the analysis of fuel gases ; (2) the analysis of combustion products ; and (3) the determination of small quantities of constituents such as ammonia or benzol in scrubbed gases in by-product carbonisation practice.

#### SAMPLING

The question of sampling will first receive attention, since a sample which is incorrectly taken will not be representative of the gas under examination, and conclusions based on the result of the analysis, however accurate that may have been, will be not only valueless, but misleading.

The gas to be sampled may be hot or cold, at rest or in motion in a flue or pipe, and at a pressure below or above that of the atmosphere ; consequently the method must be adapted to the conditions. In technical practice samples are usually taken from gases in motion in pipes or flues ; stationary gases, unless highly compressed in cylinders, are less frequently dealt with.

The first step is to introduce a suitable sampling pipe into the gas stream, and in so doing it must be remembered that there is invariably a stagnant layer of gas, whose thickness is a function of the velocity, in contact with the walls of a flue ; hence the sampling pipe must be sufficiently long to project well into the stream. It is sometimes recommended that the sampling pipe should pass right across the flue, with a long slit cut in it facing the flow of the gas. The value of such a device is very doubtful, since there is no assurance that each portion of the slit is contributing its due quota to the sample taken. On the contrary, the greater part is sure to be taken from the end of the slit nearest the delivery end of the sampling tube, in other words, where the gas velocity is low, and if the slit extends right to the inner side of the flue wall, the sample will be made up almost exclusively of the " dead " gas film and will be quite useless.

For the same reason a pipe pierced with fine holes is useless ; some, at any rate, of the holes are certain to become blocked with dust and grit, and unless the sample is drawn off very rapidly, the probability is that one hole only will supply all the sample.

## Sampling

The only satisfactory arrangement is to use a simple straight tube passing into the centre of the gas stream. The sample is thus taken at a known point, which is chosen by experiment by making a series of tests to determine from which place a sample should be withdrawn, so as to indicate by variations in composition, fluctuating conditions in the plant. For example, the correct sampling point in a boiler flue should provide an observer with gas samples of composition changing with the variations in the conditions of the fires.

Sampling tubes which are fixed permanently in position should be of ample bore to avoid clogging and choking with dust and grit in the gases. It is good practice to use  $\frac{3}{4}$ -in. gas barrel, and when it is desired to bring the sample pipe some distance to a point at which a gas-collecting device may be conveniently set up, changes in direction should be made by using crosses and plugs instead of the more slightly bends and elbows. Crossed and plugged pipes can be cleaned without taking the sampling line down as would be necessary were bends and elbows used.

The material of the tubes is important, since not only must the tubes be mechanically strong and resistant to corrosion by the gases passed, but they must be of such a composition that the gases passing shall not be altered by catalysis during passage through them.

Glass tubes are unaffected by corrosion ; they are chemically inert and are readily cleaned, but are fragile and unsuitable for use at high temperatures. Glazed porcelain or silica tubes may be used at temperatures at which glass would soften, but must be protected against mechanical breakage.

In practice, iron gas piping is commonly employed owing to its strength and cheapness, but every sampling problem must be considered on its merits and with an eye to the possible errors which may be introduced by the material of which the sampling pipes are constructed. In dealing with very hot gases, such as preheated producer gas between the regenerators and burners of steel or glass furnaces, water-cooled sampling tubes should be used, both to protect the pipes and apparatus and to cool the gases rapidly to minimise the risks of change of composition due to shifting of the equilibrium during more protracted cooling.

When the gas is at a pressure below that of the atmosphere there is always a risk of inleakage of air ; samples must therefore be drawn as near to the point of origin of the gases as possible. For example, waste gases from a boiler should be sampled before the damper and not in the breeching or at the stack. It is common to find samples taken at the base of the chimney stack, a practice which is wrong if it is desired to draw conclusions as to the composition of the gases leaving the boiler heating-surface. There is likely to be leakage of air round the damper, through cleaning doors and



## Fuel Testing

through cracks and pores in the brickwork ; hence samples taken at the base of the stack are unlikely to provide useful information as to the composition of the boiler gases as such. On the other hand, comparison of the analyses of waste gases sampled just before the damper and also at the base of the chimney, is likely to prove illuminating to those responsible for the operation of a boiler plant,

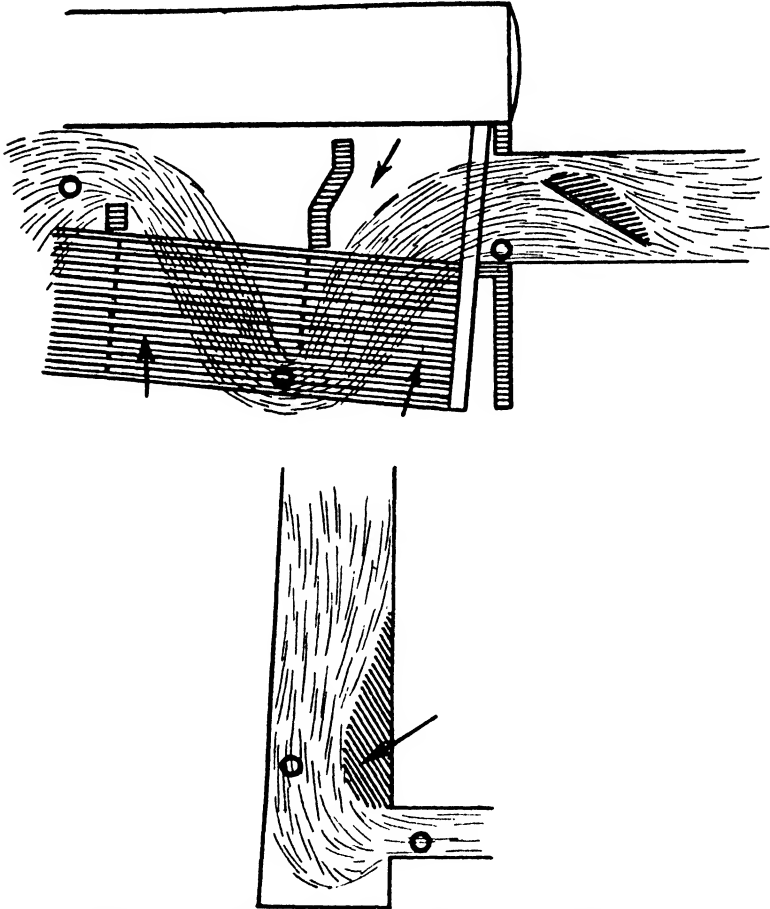

FIG. 21.—Diagrams Illustrating the Formation of Pockets of "Dead" Gas.

as it is only by such a comparison that the magnitude of any leaks can be evaluated.

The possibility of encountering pockets of "dead" gas must always be taken into account, as any change of direction, constriction or obstruction in a flue or gas passage will inevitably result in their formation.

A short discussion on the position of dead gas pockets with reference to boiler flues and passages will be found in Circular No. 7

## Sampling

(April, 1918) of the University of Illinois Engineering Experiment Station.<sup>1</sup> Fig. 21 is based on figures given in that memoir. Gas samples taken from points marked with arrows will be valueless and will give no useful information. The correct positions for sampling are indicated on the diagrams by circles. In any case, the exact position from which samples should be drawn on any particular plant must finally be determined by experiment, the diagrams given can only be used as a general guide.

In dealing with waste combustion products the common practice is to carry out the analysis on the plant, and the (portable) gas analysis apparatus is employed both for the collection and the analysis of the sample. This provides for the taking of "snap" samples, but when it is desired to take an average sample over a protracted period, or if the sample is to be taken to the laboratory for more detailed examination, other means of collection must be adopted.

A convenient arrangement for snap samples is to use glass sampling bulbs of 200 to 250 ml. capacity, and provided with a tap at each end, connected to the end of the sample pipe by a *short* length of india-rubber pressure tubing (see Fig. 22). If the gas is at a pressure above atmospheric, the sample pipe is cleared of air by letting the gas blow through: the sample bulb filled to the end of the capillary tube above the upper tap with mercury, a mixture of equal volumes of glycerine and

water, or some other liquid inert to the gas, and is attached to the end of the sampling pipe. The liquid in the sample bulb is allowed to run out, its place being taken by the gas. When the bulb is full, the lower tap is closed and then the upper; by this means the bulb is filled with gas at a pressure somewhat above that of the atmosphere, and leakage of air into it at a later stage is prevented.

If the sample is to be sent by post, or if it is to be kept for reference purposes, a bulb without taps may be used, the upper and

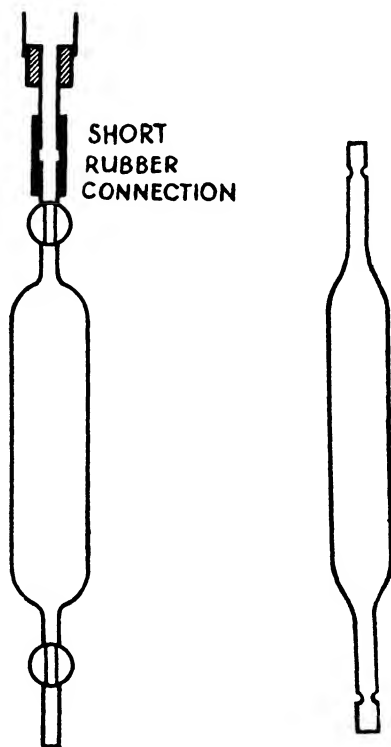

FIG. 22.—Bulbs for Sampling Gases.

## Fuel Testing

lower capillaries being drawn out into constrictions which are sealed off in a flame when the bulb has been filled.

If the gas is at a pressure below that of the atmosphere, the sample pipe may be cleared of air by interposing between its end and the collecting bulb a T piece whereby connection to an exhaust pump may be made. When the sampling pipe has been thoroughly swept out, the connection between the T piece and the pump is closed by suitable means, and the gas is sampled by running liquid out of the collecting bulb as before; alternatively the pump may be attached to the lower capillary and the air in the sampling line may be swept out via the bulb.

Large samples intended to be representative of gas over a considerable period are frequently taken in glass or metal holders filled with liquid, the liquid being allowed to dribble out slowly. A little consideration will show the error of such a practice, since the rate of flow of the liquid is a maximum when the head is greatest, i.e. at the beginning, and falls off progressively as the level in the container falls.

To obtain an average sample during several hours the only satisfactory method is to use a constant-head sampler, such as that described in connection with the low temperature carbonisation apparatus. The gas collector may be mounted on a wooden stand with small wheels, enabling it to be moved about the plant as required.

Provided the flow of gas is reasonably steady, a gasholder filled with a suitable confining liquid may be used, and a constant predetermined quantity of the liquid may be run out at regular intervals. This method is less satisfactory than the above, since not only is the sample collected on a time basis instead of a volume basis, but also the apparatus needs frequent attention.

## Confining Liquids

Liquids over which samples are taken must be without action on the constituents of the gas being collected, or the composition, as shown by the analysis, will be different from that of the original gas. Water is commonly used in technical work, but its solvent power for certain gases is considerable.

A mixture of equal parts by volume of glycerine and water which has been well boiled is frequently used, and is generally satisfactory for gases such as coal-gas or producer-gas. Prior to use, the liquid should be saturated with the gas which is to be dealt with. It should, however, be remembered that glycerine and water which has attained equilibrium with a gas rich in (say)  $\text{CO}_2$  will give up  $\text{CO}_2$  to a gas which is poor in that constituent.

Mercury is often employed where the cost and weight are not

## General Methods of Gas Analysis

prohibitive, and where the gases to be handled are without action on it.

A saturated solution of salt in water is used for collecting chlorine, which would attack mercury.

Gas samples should never be left in contact with a confining liquid for longer than is absolutely necessary, but should be transferred as soon as possible to a holder over mercury.

How misleading may be the results obtained by analysing a gas which has been allowed to stand overnight in contact with glycerine and water is shown by the following analyses of the gas from the carbonisation of a brown coal :

	Original Analysis of Fresh Gas. Per Cent.	Analysis made Next Day. Per Cent.	Calculated to 52.2 Per Cent. CO <sub>2</sub> + H <sub>2</sub> S. Per Cent.
CO <sub>2</sub> + H <sub>2</sub> S . . . . .	52.2	43.5	52.2
O <sub>2</sub> . . . . .	0.2	0.45	0.4
C <sub>n</sub> H <sub>m</sub> . . . . .	3.7	4.05	3.4
CO . . . . .	10.5	12.05	10.2
CH <sub>4</sub> . . . . .	27.2	32.1	27.2
H <sub>2</sub> . . . . .	3.0	6.3	5.3
N <sub>2</sub> (by difference)	3.2	1.55	1.3

### GENERAL METHODS OF GAS ANALYSIS

1. Absorption of the constituent sought from the gaseous mixture by a reagent, the reduction in volume or in pressure being measured.

2. Combustion or explosion of one or more constituents with oxygen or an oxygen-producing substance, the contraction after combustion being measured, and also the contraction after removing one or more of the combustion products by absorption.

3. Direct or indirect titration of the constituent sought, as in volumetric analysis.

4. Gravimetric estimation of a constituent by absorption in a substance with which it forms a compound capable of being weighed, or whose increase in weight after the absorption can be accurately determined.

### Gases Measured Volumetrically or Manometrically by Absorption

1. Carbon dioxide. Caustic soda or caustic potash solution.
2. Unsaturated (heavy) hydrocarbons. Absolute alcohol, fuming sulphuric acid or bromine water.

## Fuel Testing

3. Oxygen. Alkaline pyrogallol solution, sodium hydrosulphite or phosphorus.

4. Carbon monoxide. Alkaline or acid cuprous chloride solution.

## Gases Estimated by Combustion or Explosion

Combustible gases, particularly those not susceptible of absorption by reagents, such as hydrogen and paraffin hydrocarbons, are determined by combustion or explosion with suitable excess of either air or oxygen, the diminution in volume or in pressure being measured, and also the contraction, after absorption by caustic potash, of any carbon dioxide produced.

## Gases Estimated Directly or Indirectly by Titration

Ammonia and sulphuretted hydrogen.

### ABSORBENTS USED IN ABSORPTION ANALYSIS OF GASES

#### Absorption of Carbon Dioxide

Caustic potash is preferable to caustic soda, since the action on glass is less. The potash used should not be "purified by alcohol." With strong solutions, absorption is complete in a minute without agitation. In dealing with mixtures rich in ethylene, solid potash should be used.

#### Absorption of Heavy Hydrocarbons

The heavy hydrocarbons generally met with are the olefines ( $C_nH_{2n}$ ), especially ethylene, propylene and butylene; acetylene and benzene hydrocarbons, particularly  $C_6H_6$  and  $CH_3 \cdot C_6H_5$ .

*Fuming Sulphuric Acid.*—20 per cent. oleum. This should be kept and used above  $15^\circ C.$ , as at lower temperatures some pyrosulphuric acid crystallises out. Although heavy hydrocarbons are readily absorbed, this reagent also slowly absorbs a little methane and ethane, but no appreciable error is caused if the time of contact does not exceed 15 minutes; higher paraffin hydrocarbons are more soluble.

*Bromine Solution.*—This should be made by dissolving bromine in 10 per cent. potassium bromide to give a deep yellow solution. The strength should be so adjusted that there is little or no action on mercury.

*Absorption of Acetylene.*—A solution of silver chloride in ammonia.

#### Absorption of Oxygen

*Phosphorus.*—Yellow phosphorus cast into sticks is sometimes used. 1 gm. phosphorus absorbs 538 ml. oxygen. The water used

## Explosion and Combustion Methods

as a seal, which dissolves the phosphorus and phosphoric acids formed, must be renewed from time to time. Absorption should be carried out between 15° and 20° C. Certain gases such as tar fog, unsaturated hydrocarbons and ammonia inhibit oxygen absorption, and a little of the combustible gases may be oxidised during removal of oxygen. The phosphorus used should be shielded from light, otherwise a layer of red phosphorus will be formed on the surface.

*Alkaline Pyrogallol.*—The absorbing power is a function of the alkalinity. Absorption of oxygen by alkaline pyrogallol is slower than that of carbon dioxide by KOH.

*Sodium Hydrosulphite.* —  $\text{Na}_2\text{S}_2\text{O}_4 + \text{O}_2 + \text{H}_2\text{O} = \text{NaHSO}_4 + \text{NaHSO}_3$ . One gram absorbs 128 ml. oxygen. The reagent is used in weakly alkaline solution. 50 gm. of commercial sodium hydrosulphite in 250 ml. of water are mixed with 40 ml. of a solution of 500 gm. NaOH in 700 ml. of water. The absorption is independent of temperature and there is no absorption of carbon monoxide. The reagent is unaffected by unsaturated hydrocarbons.

### Absorbents for Carbon Monoxide

The best and only reliable absorbent is ammoniacal cuprous chloride. An acid solution, although it absorbs carbon monoxide slowly, is unreliable in its action and results. Cuprous chloride also absorbs oxygen and the olefines which must therefore always be removed before its application. When freshly prepared from pure, white crystalline  $\text{Cu}_2\text{Cl}_2$ , the ammoniacal solution absorbs carbon monoxide as rapidly as potassium hydroxide does carbon dioxide. The presence of the green oxychloride in  $\text{Cu}_2\text{Cl}_2$  reduces the rate of absorption and is therefore to be avoided.

After ammoniacal cuprous chloride the gas must be washed with dilute sulphuric acid to remove ammonia.

## EXPLOSION AND COMBUSTION METHODS

In order that the results of an explosion analysis of mixtures of hydrogen and hydrocarbons shall be accurate, it is necessary to have sufficient oxygen present, not only to ensure complete combustion, but also to act (together with any nitrogen) as a diluent to reduce the temperature of the explosion and so to avoid oxidation of nitrogen. Too big an excess of oxygen is preferable to too little, because if the mixture has been so diluted that it will not explode, the addition of a little electrolytic gas ( $2\text{H}_2 + \text{O}_2$ ) will make it combustible.

In dealing with mixtures of hydrogen and methane, there should be diluents present to the extent of about 2.5 times the volume of the reactive mixture.

E.g.,  $\text{CH}_4 + 2\text{O}_2 = \text{CO}_2 + 2\text{H}_2\text{O}$ . The reactive mixture consists

## Fuel Testing

of two volumes of oxygen and one volume of methane, or a total of three volumes; hence the diluents should amount to 7.5 volumes, and the total volume of gas for explosion to 10.5 volumes. In other words, for every volume of methane present in a mixture, 9.5 volumes of oxygen should be added.

$2\text{H}_2 + \text{O}_2 = 2\text{H}_2\text{O}$ . Two volumes of hydrogen require one volume of oxygen for their combustion, giving three volumes of reactive mixture. 7.5 volumes of excess oxygen are required, giving 10.5 volumes of gas for explosion, or for every volume of hydrogen present in a gas, 4.25 volumes of oxygen should be added to give a mixture of suitable dilution for explosion.

Consider a coal gas residue consisting of methane, hydrogen and nitrogen in the proportion of 4 : 8 : 1, and calculate the necessary oxygen to be added for the explosion of 13 volumes of such a mixture.

Four volumes of methane require 8 volumes of oxygen; 8 volumes of hydrogen require 4 volumes of oxygen. The total volume of reactive mixture will therefore be 24. The inerts should amount to  $24 \times 2.5$  or 60 volumes, of which the nitrogen will account for 1 volume. Hence the oxygen present to give the necessary inerts will be  $60 - 1$  or 59 volumes, and the total volume of gas to be exploded will be

Gas residue . . . . .	13
Oxygen for combustion . . . . .	12
Oxygen as inert gas . . . . .	59
	—
Total gas for explosion . . . . .	84

The oxygen to be added will be 71 volumes or about  $5\frac{1}{2}$  times the volume of the coal gas residue.

If there is no idea as to the composition of a gas residue, it will be necessary to make a preliminary analysis, using a large excess of oxygen, and in the light of the results obtained, the analysis must be repeated, making the mixture up to more nearly the correct dilution.

There is generally sufficient gas residue for several tests, and as a rule part only of this residue can be used for any one test, as the volume of gas plus the necessary oxygen is usually too great for the whole of the residue to be used at once, hence a portion may be rejected into a separate holder and used to make a second test in the light of the results obtained in the first.

The flame in the explosion pipette should be distinctly visible travelling down the tube; an instantaneous flash shows that too strong a mixture is being used.

After the explosion, the volume of gas remaining is determined, the gas is treated with caustic potash solution to dissolve  $\text{CO}_2$ , and the diminution in volume is noted.

### Changes in Volume on Combustion and Subsequent Absorption of Gases and Gas Mixtures

*Hydrogen.*— $2\text{H}_2 + \text{O}_2 = 2\text{H}_2\text{O}$  (condensed). Contraction ( $C$ )=3, absorption ( $A$ ) = 0,  $C/A$  = infinity.

*Methane.*— $\text{CH}_4 + 2\text{O}_2 = \text{CO}_2 + \text{H}_2\text{O}$  (condensed),  $C/A$  = 2.0.

*Ethane.*— $2\text{C}_2\text{H}_6 + 7\text{O}_2 = 4\text{CO}_2 + 6\text{H}_2\text{O}$ ,  $C/A$  = 1.25.

For propane  $C/A$  = 1.00, for butane  $C/A$  = 0.875, and for pentane  $C/A$  = 0.75.

If a mixture of hydrogen and methane is being dealt with, the volume of the methane is equal to that of the  $\text{CO}_2$  produced, =  $A$ , while the hydrogen can be shown to be  $\frac{2}{3}(C - 2A)$ .

The individual components of gas mixtures containing more than two combustibles cannot be estimated by a simple explosion analysis, although useful information is supplied by the  $C/A$  ratio.

Since for hydrogen  $C/A$  is infinite, and for methane the value is 2.00, it is evident that whenever a residue contains as combustibles hydrogen and methane, the ratio will exceed 2.0, although such a  $C/A$  ratio does not preclude the presence of higher homologues of methane, provided that there are more than 4 atoms of hydrogen present for every atom of carbon. Thus a mixture  $4\text{CH}_4 + \text{C}_2\text{H}_6 + 2\text{H}_2$  would, by explosion analysis, appear to consist of  $6\text{CH}_4 + \text{H}_2$ —in other words, of 85.7 per cent. of methane and 14.3 per cent. hydrogen. The important point is that the number of combustible molecules per cent. would be correct, and if the mixture were a gas residue containing also nitrogen, there would be no error in the result for nitrogen as determined by difference.

Values of  $C/A$  intermediate between the figures for individual hydrocarbons given above indicate that the composition of the gas mixture is equivalent in composition to a mixture of hydrocarbons whose  $C/A$  values are those lying on either side of the observed ratio. Thus if a ratio of 1.36 were found, the mixture would be calculated as methane and ethane, and a ratio of 1.1 would indicate an effective composition between ethane and propane. Supposing that 100 parts of a gas give  $C = 251$ , and  $A = 216$ , the ratio  $C/A$  is 1.17.

If  $x$  be the percentage of ethane and  $y$  the percentage of propane, then  $2\frac{1}{2}x + 3y = 251$  and  $2x + 3y = 216$ , whence  $x = 70$  per cent. and  $y = 25.3$  per cent.; the 4.7 per cent. balance would be returned as "nitrogen plus errors" or "nitrogen by difference."

To obtain further information as to the composition of the mixture, other means must be adopted, such as the preferential combustion of any free hydrogen by means of copper oxide or "oxidised" palladium, or liquefaction of the gas residue in liquid air, the various hydrocarbons being isolated in a nearly pure condition



## Fuel Testing

by fractionation at suitable temperatures. When the method of preferential combustion of the hydrogen is employed, the diminution in volume arising from removal of the hydrogen is measured, and the residual gas is exploded with oxygen in the usual way, and from the  $C/A$  ratio the effective composition is calculated as above.

If information is required as to precisely which hydrocarbons are present, and in what proportions, the fractionation method must be adopted.

### PREFERENTIAL COMBUSTION OF HYDROGEN

#### Determination of Hydrogen by Means of Palladium

This method was described by W. A. Bone and D. S. Jordan,<sup>2</sup> and consists in absorbing the greater part of the hydrogen by pal-

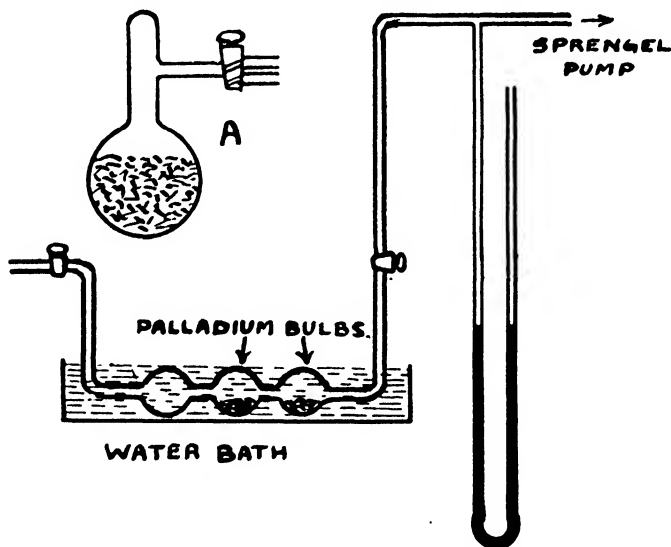

FIG. 23.—Apparatus for Combustion of Hydrogen over Oxidised Palladium.

ladium sponge or foil at 100° C., and in a second operation removing the remainder by combustion on oxidised palladium sponge (prepared by heating spongy palladium to red heat in air) at 100° C. Full details may be found in the original paper; the following brief description refers to its use on gas residues after absorption of carbon monoxide by cuprous chloride.

The preliminary absorption of hydrogen is carried out in an evacuated flask of about 150 ml. capacity, packed with some 30 gm. of small pieces of thin palladium foil, heated in a water-bath at 100° C. (Fig. 23). Most of the hydrogen is rapidly absorbed, and

## Preferential Combustion of Hydrogen

after removing the water-bath, the residual gas is withdrawn from the flask by a Sprengel or other suitable pump and transferred to the apparatus in which final removal of hydrogen by oxidation takes place.

The apparatus consists of a tube provided with three bulbs, as shown in Fig. 23, two of which contain oxidised palladium sponge while the third serves to catch any mercury which may be blown in while the gas is being transferred and which would inhibit the action of the palladium. The apparatus is evacuated by means of the Sprengel pump and at the same time, the water-bath is brought to the boil. When evacuation is complete, the gas residue from which most of the hydrogen has been removed is carefully introduced. The progress of the reaction is watched by observing the manometer and, when no further change is noted, the water-bath is lowered, the bulbs are allowed to cool, and the residual gas is transferred to a test tube via the Sprengel pump, and returned to the gas analysis apparatus for measurement and subsequent explosion with oxygen for determination of hydrocarbons.

"Oxidised" palladium has a characteristic dark blue tint, while palladium sponge is grey, therefore as soon as any sign of grey colour is observable in the contents of the bulbs re-oxidation must be carried out.

## Combustion of Hydrogen by Means of Copper Oxide

The process consists in burning the hydrogen in contact with copper oxide heated to  $280^{\circ}$  C., for which purpose the apparatus described by J. G. King and L. J. Edgcombe<sup>3</sup> (Fig. 24) may be used.

The glass tube connecting C to the gas analysis apparatus should be a capillary.

The copper oxide is contained in a thin-walled silica tube C of about 5 ml. capacity, containing 20 gm. of CuO. The combustion tube and connections are first evacuated, and the gas residue is allowed to pass into C heated by means of a small electric furnace to  $280^{\circ}$  C. Cock D is opened, and the gas is passed backwards and forwards through C until no further change in volume occurs. The remaining gas is returned to the gas analysis apparatus and measured before exploding with oxygen as usual.

It is possible subsequently to oxidise the saturated hydrocarbons by raising the temperature of the copper oxide in C to  $900^{\circ}$  C. and passing the gas residue several times through C just as in the removal of hydrogen. This is not recommended, since at  $900^{\circ}$  C., and in the presence of copper oxide, the silica tube rapidly becomes devitrified and is then liable to fail.

## Fuel Testing

The following precautions are necessary :

- (i) Special attention must be taken that the stop-cocks are tight.
- (ii) The temperature of the combustion tube must be maintained at  $280^{\circ}\text{C}$ ., and the remainder of the gas analysis apparatus must be protected from radiant heat, and
- (iii) No mercury must at any time be allowed to enter the capillaries between R and C.

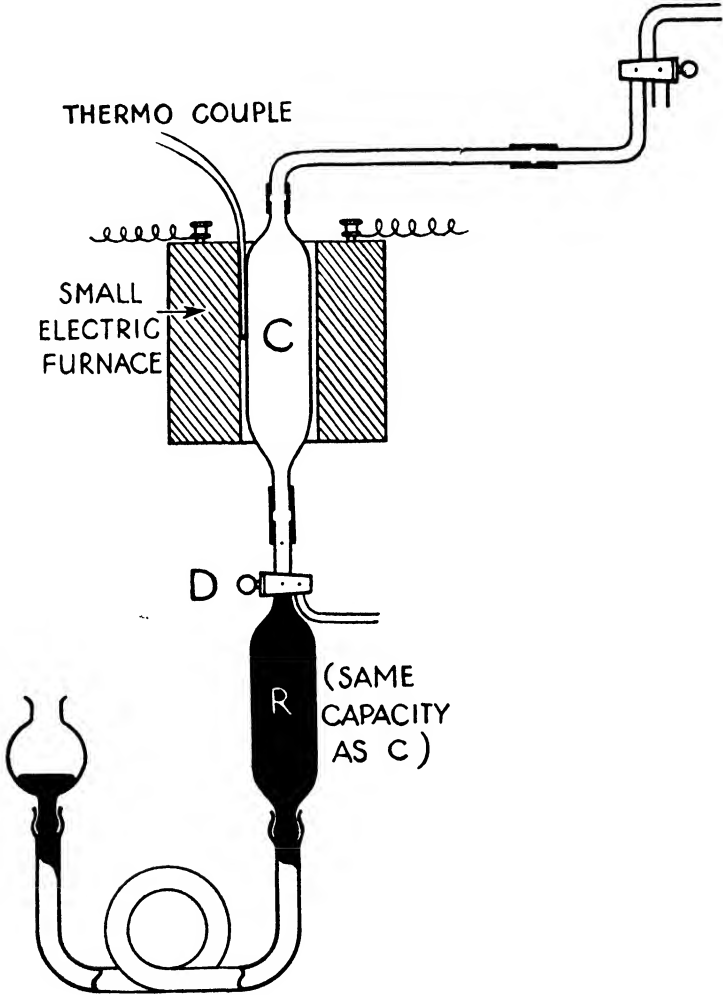

FIG. 24.—Apparatus for Combustion of Hydrogen over Copper Oxide.

After several determinations, the copper oxide becomes reduced to metallic copper ; to re-oxidise it, the temperature of the combustion furnace is raised to  $600^{\circ}\text{C}$ . and air is drawn through the tube C.

## Apparatus Used for Gas Analysis

### APPARATUS USED FOR GAS ANALYSIS

Although the forms of apparatus used for gas analysis are legion, they may be divided into two main categories; the first embraces all types of apparatus depending on volumetric measurement of the gas at constant pressure, and the second includes apparatus in which manometric measurement is employed, the pressure of the moist gas at constant volume being measured.

The volumetric type may be further divided into apparatus in which absorption is carried out in the measuring burette (Winkler and Bunte), and apparatus having separate absorption vessels which may or may not be permanently connected to the measuring burette. The former subdivision is typified by the Hempel apparatus with its various modifications, while the latter arrangement is found in the Orsat apparatus and in portable apparatus generally.

Portable gas analysis apparatus may be carried out on to the plant and tests may be made *in situ*, the apparatus may be adapted only for use in a laboratory. The choice of a particular form of apparatus must depend on the type of work for which it is required, with a view to the degree of accuracy necessary, to the first cost and to the degree of skill which is available for its use.

For general laboratory and research purposes, the Bone and Wheeler or the Bone and Newitt apparatus (described later) are preferable to other forms, since they yield accurate results, are adaptable to the analysis of all kinds of gas mixtures, and in the hands of a skilful worker are rapid in operation; the first cost, however, is somewhat high. Where conditions do not justify such an apparatus, the improved Hempel apparatus may be installed. Where a portable apparatus is required for the analysis of boiler flue gases, the Author has used the Hays modification of the Orsat apparatus.

It must be remembered that if a gas is analysed under constant-pressure conditions in an apparatus, the interior of which is wet with water, the result will be the analysis of the *dry* gas. Suppose 100 ml. of gas to be measured saturated with water vapour, the vapour tension of water being 15 mm. and the total pressure of the wet gas 750 mm., then the actual volume of dry gas will be  $100 \left(1 - \frac{15}{750}\right)$  or 98 ml. If now, after an absorption, the residual volume is found to be 85 ml. this will be made up of  $85 \left(1 - \frac{15}{750}\right)$  or 83.3 ml. of dry gas, i.e. the percentage of dry gas absorbed was  $\left(\frac{98 - 83.3}{98}\right) 100$  or 15. In other words, the diminution in volume of the wet gas will bear the same ratio to the total volume as if the gas had been measured dry.

## Fuel Testing

On the other hand, if gas saturated with water vapour be measured in an apparatus whose interior is *dry*, and if the gas then be brought into contact with (say) a concentrated solution of caustic potash, such as is employed in the Bone and Wheeler apparatus, part of the water vapour in the gas will be abstracted by the caustic potash, the result being that the reduction in volume will be made up of that arising from absorption of acid gases plus the (unknown) amount of water vapour removed.

In apparatus of the constant-volume type having a *closed* barometer tube (such as the Bone and Wheeler or the Bone and Newitt), provided the gas and barometer tubes are internally wet, the pressure reading will be that of the dry gas, since the pressure exerted by the water vapour in one tube will be balanced by that in the other.

### THE IMPROVED HEMPEL APPARATUS

The improved Hempel burette is made in three forms, as illustrated in Fig. 25. The measuring tube may be of uniform internal diameter, and have a capacity up to 100 ml., this form being suitable for use where it is necessary to measure a relatively small residue after successive absorptions to the same degree of accuracy as was obtainable for the initial measurement; it may have a portion at the upper end of diameter greater than that of the main part of the measuring tube, the total gas capacity then being about 150 ml., this type being particularly useful where it is desired to measure a relatively large quantity of gas and to remove by absorption quantities of constituents less in volume than the capacity of the narrower portion of the burette: or, finally, the upper portion of the tube may be of much narrower bore than the lower portion, an arrangement particularly adapted to the analysis of gases which are made up of a high percentage of an absorbable constituent, so that perhaps 90 per cent. or over may be removed in the first absorption, the remaining absorptions removing quantities of the order of 1 or 2 per cent.

The first form, A, is particularly adapted to the analysis of gases containing a number of constituents present in more or less equal proportions; the second, B, is peculiarly suitable for the analysis of coal-gas, where from 20 to 25 per cent. may be removable by absorption, as the extra capacity of the enlarged upper portion of the tube enables a larger amount of residue to be taken for explosion, since there is room for a correspondingly greater quantity of oxygen to be mixed with it and measured before the explosion; the third form, C, is adapted for use with small quantities of gas, and for dealing with special gases, such as those obtained by the low tem-

## Improved Hempel Apparatus

perature decomposition of brown coals and lignites, in which case there may be 90 per cent. or more of carbon dioxide, together with small quantities of other constituents whose volume may be measured with considerable accuracy in the narrow upper part of the tube.

This form of Hempel apparatus is fitted with a compensating device whereby errors which would otherwise arise from changes in

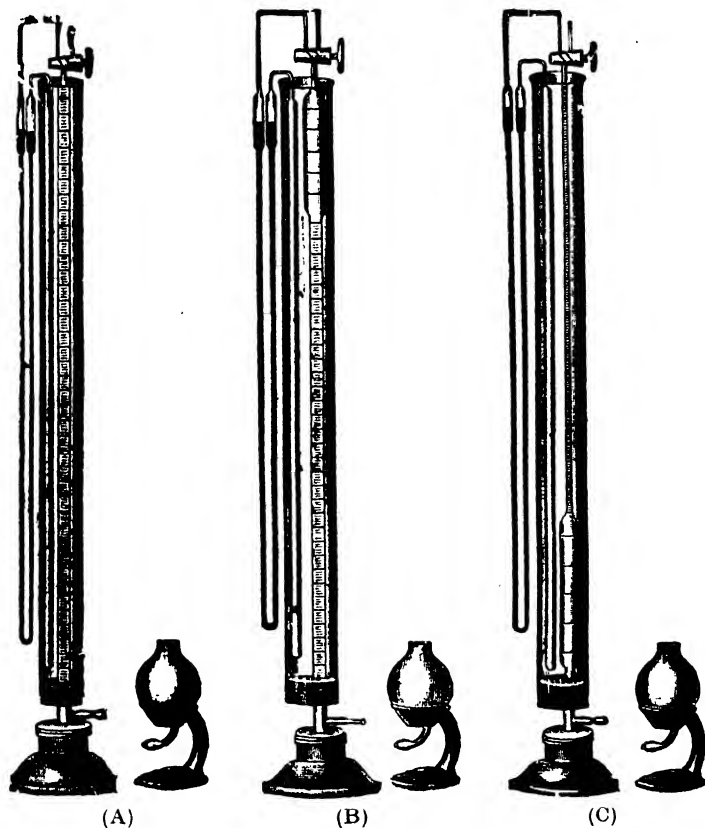

FIG. 25.

- A. Hempel's Gas Burette, with correction for variations in temperature and barometric pressure. Gas quantities from 0.5 to 100 ml., complete with stand (Hempel's "Methods of Gas Analysis," p. 61).
- B. Hempel's Gas Burette, for gas quantities of about 150 ml.
- C. Hempel's Gas Burette, for gas quantities of about 10 ml.

(By courtesy of A. Gallenkamp & Co., Ltd.)

temperature and/or pressure of the atmosphere during an analysis are eliminated. This is accomplished by means of a device due to Petterson, which consists of an elongated glass bulb closed at the lower end and connected to the upper end of the measuring burette via a long mercury manometer and one limb of a two-way cock. The compensating bulb and the burette are enclosed in a water

## Fuel Testing

jacket which serves to maintain them at a relatively uniform temperature. The upper ends of the manometer tube are enlarged, and about the middle of the enlarged portion on each limb a mark is scratched at exactly the same height. The compensating tube having originally been filled with air at a definite temperature and pressure, it follows that if, when a gas measurement is to be made in the burette, the two-way cock is turned so as to bring the mano-

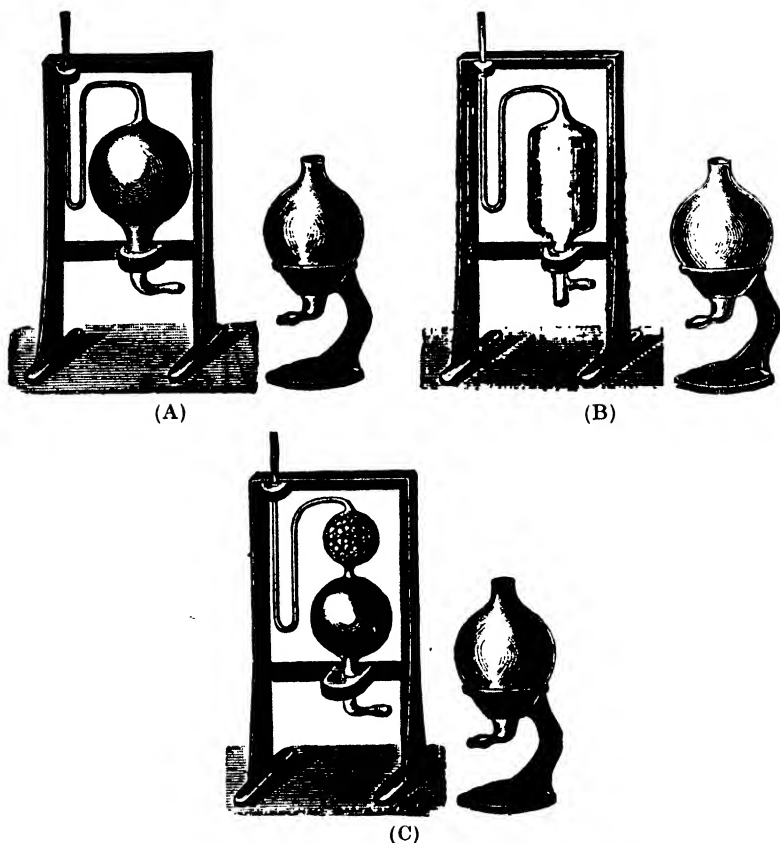

FIG. 26.—Various Types of Absorption Pipettes for Use with Hempel's Gas Burette.

(By courtesy of A. Gallenkamp & Co., Ltd.)

meter into communication with the measuring burette, then when the mercury in the levelling vessel is adjusted so as to bring the mercury in the manometer exactly to the marks thereon, the volume of gas read off will be automatically corrected to the temperature and pressure at which the compensating tube was originally filled, consequently, variations in temperature and pressure of the atmosphere are allowed for, and can introduce no errors during an analysis.

## Improved Hempel Apparatus

The confining liquid used in the apparatus is mercury; the absorption pipettes are also mercury-filled, and consist of single or two-bulbed pipettes each provided with a mercury levelling vessel.

Three types of pipette are illustrated in Fig. 26, the first, A, for use with liquid reagents, the second, B, provided below with a tubulure which is closed by a rubber stopper, is used for solid reagents such as phosphorus, and the third, C, is provided with an upper bulb filled with glass beads, where it is desired to increase the surface of contact between the gas and the reagent. The third form of pipette is used for absorptions with fuming sulphuric acid. In using this two-bulbed pipette, there is a danger with viscous reagents that bubbles of gas will be trapped amongst the beads forming the packing in the upper bulb, and that such bubbles will not easily be collected and transferred back to the measuring burette after the absorption.

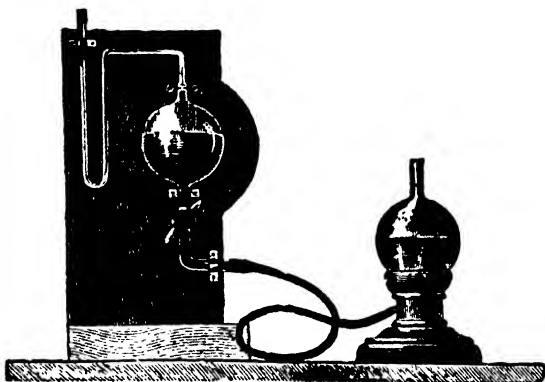

Fig. 27.—Hempel Explosion Pipette.

(By courtesy of A. Gallenkamp & Co., Ltd.)

Small quantities only of the various reagents are used in the pipettes, only enough reagent for two or three analyses being introduced at any one time, therefore the risks of inaccuracy owing to the use of stale absorbent solutions are reduced.

The explosion pipette is similar to the one-bulb absorption pipette, but is provided with two platinum firing wires which are fused into the upper neck of the pipette just below the capillary tube, and also with a stop-cock in the lower neck (see Fig. 27).

When an absorption is to be carried out, the appropriate pipette is connected to the two-way cock on the measuring burette by means of a *short* inverted U of capillary tubing and two connections of india-rubber pressure tube, the connections being made so that glass touches glass.

The strength of caustic potash solution used in connection with the Hempel apparatus may conveniently be made weaker than that



## Fuel Testing

used for the Bone and Newitt (*infra*), and may be made by dissolving 250 gm. of good commercial caustic potash in 800 ml. of water.

The other reagents may be prepared as described under the heading "Bone and Newitt Gas Analysis Apparatus."

A modification of the Hempel apparatus, in which the pipettes are permanently connected to the measuring burette by means of a manifold, has been described by R. V. Wheeler.<sup>4</sup>

### THE HAYS MODIFICATION OF THE ORSAT APPARATUS

On the works, an apparatus is needed which can be carried out on the plant, and in which samples of flue gases, etc., may be taken and rapidly analysed with reasonable accuracy, both to act as a

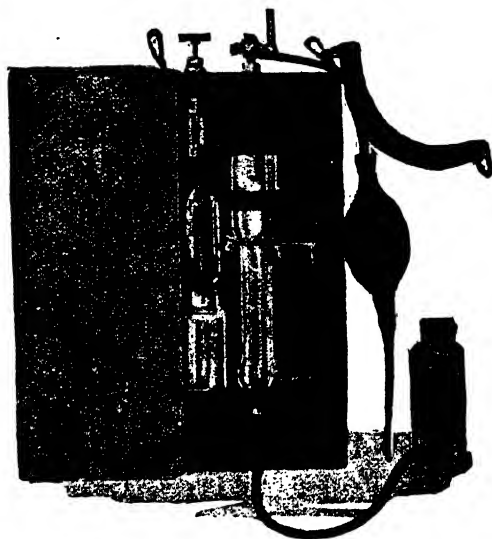

FIG. 28.—Hays Portable Gas Analyser. For CO<sub>2</sub> only.

(By courtesy of Duguids, Ltd.)

check on the indications of recording gas analysis apparatus and also to keep a running check during trials of plant. For boiler control, rapid analyses of the waste gases are required which will indicate the effects of varying conditions in the furnace, and for this purpose a portable gas apparatus is necessary.

The apparatus preferred by the Author is the Hays modification of the well-known Orsat apparatus; it is extremely portable and robust, and with a little practice may be used by almost any class of worker.

The Hays apparatus (see Figs. 28 and 29) consists of a measuring burette of about 50 ml. capacity contained in a water jacket and provided with the usual type of levelling bottle. There are from

## Bone and Newitt Gas Analysis Apparatus

one to three absorption pipettes connected to the upper end of the burette via a copper capillary tube, each pipette being provided with a metal needle valve. The gas sample is introduced into the burette via a brass three-way tap instead of the usual fragile glass tap. This tap, suitably greased, is easily kept gas-tight.

The whole apparatus is contained in a janned iron case, and as the three-gas type weighs only about 8 lb. is easily carried from place to place.

The absorption pipettes are charged with (a) caustic potash solution (250 gm. in 800 ml. water); (b) alkaline pyrogallol solution (50 gm. pyrogallol dissolved in 1 litre of caustic potash as above), and (c) acid cuprous chloride solution (made by dissolving 115 gm. of solid cuprous chloride in 500 ml. of concentrated hydrochloric acid,

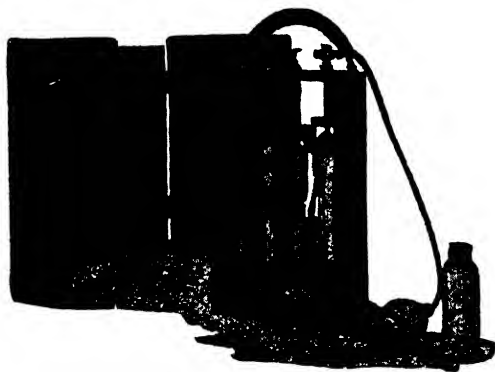

FIG. 29.—Hays Portable Gas Analyser. Three-Gas Type.  
(By courtesy of Duguids, Ltd.)

and boiling under reflux with copper gauze or turnings until colourless).

The absorptions are carried out in the usual manner, removing carbon dioxide, oxygen and carbon monoxide successively from the gas.

When using portable gas analysis apparatus, gas samples are usually taken direct into the apparatus, an india-rubber gas sampling device provided with metal clack valves being used to clear air out of the sampling pipe and to deliver gas to the apparatus. The life of these rubber sampling bulbs is short, and experience shows that a good make of rubber enema syringe has not only about double the life, but costs only half as much.

## THE BONE AND NEWITT GAS ANALYSIS APPARATUS

Whereas in most forms of gas analysis apparatus a measured volume of gas is treated with reagents, the diminution in volume after each absorption being determined in the Bone and Newitt

## Fuel Testing

apparatus (which is a modification of the Bone and Wheeler apparatus) an unknown volume of gas is expanded to a fixed (unknown) volume and the pressure exerted is measured, and also the diminution in pressure of the gas after each absorption when expanded to the same fixed volume.

The advantages are that an accurately divided lineal scale is all that is required as a means of measurement; variations in the bore of the tube containing the gas have no effect, hence calibration is much simpler, being confined to the checking of a scale of millimetres; smaller quantities of gas may be handled with accuracy in the same apparatus, since by reducing the volume to which the gas is expanded, the pressure which it exerts is increased; also variations in the height of the barometer during an analysis are without effect.

The apparatus consists of three main parts, a U-tube in which all measurements are made (E in Fig. 28), a laboratory or absorption vessel M, in which absorption of constituents of the gas by various reagents is carried out, and an explosion vessel H, wherein the gas residue after the various absorptions is exploded with oxygen.

By means of an ingenious arrangement suggested by W. E. Stockings, water pressure is employed to operate the apparatus.

The following instructions for use are given by kind permission of D. M. Newitt:

The general arrangement of the apparatus is shown in Fig. 30.

### Setting up the Apparatus

Place in a good light; by means of the levelling screws ensure that the measuring tube E is vertical. A is an ordinary glass filter pump—it should be connected to the water supply by pressure rubber tubing (wired on firmly and bound with insulating tape). If necessary, it may be situated some distance from the apparatus.

A slow stream of water should be allowed to pass through the water jacket during an analysis, and frequent readings of temperature should be taken. If fluctuations of temperature occur, an appropriate correction must be made to the pressure readings.

### Care of Glass Taps

This apparatus, in common with all apparatus working on the constant volume principle, is usually operated at reduced pressures, hence care should be taken in the maintenance of the glass taps  $T_1$ ,  $T_2$  and  $T_3$ , and the tap to the explosion vessel  $T_5$ . The taps on the apparatus as supplied are specially selected, and may be regarded as quite reliable, but they require careful use. As the taps are very accurately ground they require a minimum of lubricant. The best

## Bone and Newitt Gas Analysis Apparatus

form of grease is prepared by dissolving Para rubber in vaseline ; the rubber and vaseline are heated together in an evaporating basin over a low flame until a sample of the solution when cooled has the consistency of lard. The vaseline on the taps, as supplied, should be washed off with cotton wool damped with chloroform, and a thin film of the prepared lubricant well rubbed in and the taps replaced. When the apparatus is in use the taps require cleaning and re-greasing about once a week.

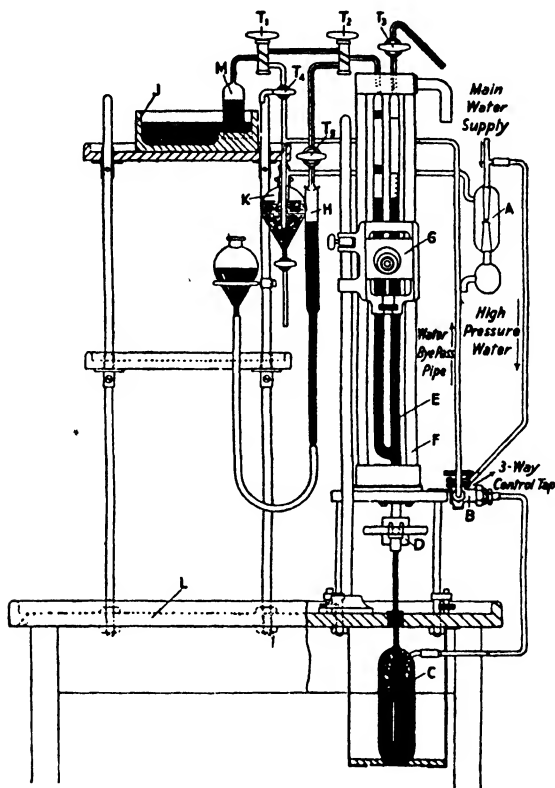

FIG. 30.—The Bone and Newitt Gas Analysis Apparatus.

(By courtesy of A. Gallenkamp & Co., Ltd.)

Whenever alkali has been used in the apparatus, it should be washed out with dilute sulphuric acid—and alkali should never be left in the apparatus for any length of time.

Never operate the taps when any mercury has been forced between the barrel and the cylinder ; remove the barrel, clean and re-grease. The lubricant should not present a streaky appearance. The bores of the taps should be cleaned when necessary by means of a plug of cotton wool on the end of a splinter of wood—not by a wire.

## Fuel Testing

### Method of Operation

All measurements are made in the U-tube E, which is kept at a known temperature; the left-hand limb has 100 mm. graduations and the right-hand limb 1 mm. graduations over a length of 650 mm. Readings are taken by means of the telescope G. The apparatus measures the pressure exerted by the gas, at constant volume, during the various stages of the analysis; a compensating method allows, automatically, for the pressure of aqueous vapour and for changes in the barometric height during an analysis; this will be referred to later.

Let us suppose the apparatus to be set up and all the connections made as shown in the figure. In the course of the analysis a considerable quantity of dilute sulphuric acid \* is used for washing purposes, and it is convenient, therefore, to have an ample supply available. For this purpose a Winchester bottle of the acid is kept on the middle shelf of the wooden stand; a glass tube is bent so that it will reach from the bottom of the Winchester bottle to a point close to the open end of the tap  $T_4$  and connection is made when required by a short length of rubber tubing.

Taps  $T_1$ ,  $T_2$ ,  $T_3$ ,  $T_4$ ,  $T_5$  and D should be closed; the three-way tap B should be open so that water may pass through it to the sump K only. Turn on the main water supply through the pump A, and ensure that there is an unobstructed flow of water through K back to the pump A. Start the water flowing through the jacket F.

Turn tap B so that water pressure is applied to the mercury in C. Slowly open D. Mercury will rise in both limbs of the tube E. It is necessary to force all air out of E, but care must be taken; if the air in E is under reduced pressure and the tap  $T_3$  is opened incautiously, the mercury will be forced round into the left-hand limb so violently that the tap  $T_2$  will be broken. This misadventure frequently happens to beginners. It can be avoided as follows: When the mercury has risen some way in E, shut the tap D. Open  $T_1$  cautiously to  $T_4$ , and in turn open  $T_4$  cautiously to K. The air in M will be drawn out, and the mercury will rise and fill the vessel; any mercury passing the tap  $T_4$  will be trapped in K. Now open  $T_1$  and  $T_2$  to E. If E is under reduced pressure, mercury will flow into it; if it is under excess pressure, air will be forced into M. Leave  $T_1$  and  $T_2$  open and re-open D; all the air in the left-hand limb of E will be forced into M, and can later be evacuated to K. Now close  $T_1$  and  $T_2$  and cautiously open  $T_3$ ; the air in the right-hand limb will in turn be forced out. Close  $T_3$  and D. Turn B to waste through K. *Never leave water pressure on C when not required.*

\* The expression "dilute sulphuric acid" in this description is to be taken to mean a solution of 1 per cent. by volume.

## Bone and Newitt Gas Analysis Apparatus

It may happen that the explosion vessel H contains air. To remove this: E is full of mercury; open  $T_2$  and  $T_3$ ; then open D; now turn B so that it connects with both C and K. Air will be sucked out of H into E, and may then be passed as before into M and so evacuated through K.

The apparatus must now be washed out with dilute acid so that all parts are moist. To do this connect the Winchester of acid to  $T_4$  and open to  $T_1$ , when acid will be drawn into M. Close  $T_4$ . Open  $T_1$  and  $T_2$ , then D and finally B, so that B connects with C and K; acid will be drawn over into the left-hand limb of E. When sufficient has passed, close  $T_2$  and then  $T_1$ . The mercury in E will continue to fall until acid passes round the bend into the right-hand limb; at this point reverse B, so that pressure is applied to C. Always take care that no acid is ever drawn into the metal tap D. When the acid reaches the top of E, open  $T_3$  and reject all in the right-hand limb; close  $T_3$  and open  $T_2$  and  $T_1$ . The acid in the left-hand limb will then pass into M. Close  $T_2$ ,  $T_1$  and D, and turn B to waste. Evacuate acid in M through  $T_1$  and  $T_4$  to K. After a little practice all these operations become automatic and run smoothly. *A golden rule is never to leave pressure or vacuum on C unless some operation is in progress.*

The apparatus should now contain no trace of gas. The next operation is to determine the zero and in so doing, incidentally, to test for leaks. All taps are closed and B is to waste. Open D and turn B and C to K. The mercury in E falls slowly and can be controlled by D. As soon as the level in E falls below the 100 mm. graduation, close D and turn B so as to put pressure on C. Focus the telescope on the 100 graduation and slowly open D until the mercury rises to the graduation on the left-hand limb. If the apparatus is gas-free, the level of mercury in the right-hand limb should also be on the corresponding graduation. If it is not so, the presence of a trace of air in the tube is indicated; repeat the operation for removing the air and again take the zero readings. Any leak at the taps  $T_2$  and  $T_3$  will at once become manifest during this operation.

*Introducing the Gas.*—The most convenient method of collecting a gas sample is in a test tube over mercury; the tube may be transferred to a crucible containing mercury and stored in a rack. To introduce such a sample into the apparatus, the crucible and end of the tube are submerged in the mercury in J, and the crucible is then removed. The end of the test tube is pushed under the absorption vessel M, and by depressing the test tube sufficient of the sample for an analysis may be transferred; the crucible can then be replaced and the remainder of the sample stored.

Samples of gas contained in burettes and the like are transferred

## Fuel Testing

to the apparatus by first connecting the storage vessel to the tap  $T_4$ . On opening  $T_4$  and  $T_1$  the weight of mercury in  $M$  will be sufficient to draw over a sample.

The gas has now to be transferred to the left-hand limb of  $E$  for measurement;  $E$  is full of mercury, open  $T_1$  and  $T_2$  cautiously, open  $D$  and turn  $B$  to  $C$  and  $K$ ; control the rate of gas transfer by means of  $D$  until mercury is drawn through  $T_1$  and  $T_2$  to a fixed mark just to the right of  $T_2$ . Close  $T_2$  and  $T_1$ . The mercury in  $E$  will continue to fall steadily. When it has reached just below the 100 mm. mark on the left-hand tube, close  $D$ , turn  $B$  to pressure, and by means of  $D$  and the telescope adjust the level to the 100 mm. mark; close  $D$ . The gas now occupies a definite volume, and is saturated with water vapour at the temperature of the water jacket, which should be noted.

*Note.*—Any of the other constant volume marks, 200 mm., 300 mm., etc., may be used. When only a small volume of gas is available for analysis, one of the other C.V. marks, 300 mm. or 400 mm., should be used, as the gas will then give a greater pressure than at the 100 mm. mark.

The pressure of the gas in  $E$  is measured by the difference in height of the mercury in the two limbs. The telescope is focussed on the right-hand limb and the height read to 0.1 mm. The space above the mercury in the right-hand limb is saturated with water vapour, and thus compensates for the pressure exerted by the vapour in the left-hand limb. Any variations in barometric height do not affect the readings, and no correction on this account is necessary.

## Selective Absorption of the Constituents of the Gas

*(Example—Coal-Gas)*

The reagents are contained in rubber- or glass-stoppered bottles of about 1 oz. capacity; for each absorption from 3 to 5 ml. of reagent are used; the reagents are drawn into the absorption vessel  $M$  by means of a piece of glass capillary, attached by rubber to the tap  $T_4$ , and dipping into the reagent bottle. If any air is drawn into  $M$  with the reagent it can be removed by opening  $T_4$  to  $K$  and then slowly opening  $T_1$ . Particulars of the strengths, etc., of reagents are given on page 170.

### *First Absorption with KOH to Remove Carbon Dioxide*

5 ml. of the reagent are introduced into  $M$  and any air drawn in is removed. The tap  $D$  is now opened and the mercury in  $E$  rises. When the mercury in the right-hand limb reaches the tap  $T_3$ , but not before, the taps  $T_2$  and  $T_1$  are opened, and all the gas is

## Bone and Newitt Gas Analysis Apparatus

allowed to pass into M.  $T_1$ ,  $T_2$  and D are closed and B is turned to waste. By gently shaking the stand the mercury in M is rocked, care being taken that the reagent does not reach the junction of the capillary with M; if it does so, reagent at a later stage will be carried over into E, which is undesirable. Three minutes should be sufficient for the absorption. Open  $T_1$ ,  $T_2$  and D; now turn B slowly so as to draw the gas from M to E; control the movement by the tap  $T_2$ ; as soon as the reagent reaches the tap  $T_1$ , close  $T_1$  and D. Take care that all gas has passed  $T_1$ , but not reagent. Evacuate the reagent to K through the tap  $T_4$ . Connect  $T_4$  to the dilute acid supply and draw acid into M. Open  $T_4$  and  $T_1$  to air, so that air and acid fill M. Evacuate both air and acid to K and close  $T_4$ . Now open  $T_1$  and  $T_2$  so that mercury is drawn along to the fixed mark beyond  $T_2$ . Close  $T_1$  and  $T_2$ . Open D and bring the mercury in the left-hand limb of E to the constant volume mark. As before, measure the height of mercury in the right-hand limb. Note the temperature of water in the water jacket.

### *Second Absorption with Alkali and Pyrogallic Acid for Oxygen*

Draw 5 ml. of KOH into M, followed by one-third of the volume of pyrogallic acid solution; shake and evacuate any air. As before, transfer the gas to M, shake gently for 5 minutes, return to E, wash out the absorption vessel with acid, and again take the pressure readings as before.

### *Third Absorption with Bromine Water for Unsaturated Compounds*

Use 5 ml.; time 3 minutes; wash out bromine water, first with distilled water and then with acid; proceed as before.

*Note.*—If the bromine water is prepared as described, it is best to pass the gas over KOH to remove any bromine vapour before measuring.

### *Fourth Absorption with Ammoniacal Cuprous Chloride for Carbon Monoxide*

If more than a trace of carbon monoxide is present, absorb with two separate quantities of this reagent; wash out reagent first with water and then with dilute acid. When M is being washed with acid, pass back the gas to remove any ammonia from the gas.

The residual gas will now contain methane, nitrogen and hydrogen. The combustible gases are estimated by exploding with oxygen in the explosion vessel H, measuring the contraction and also the amount of carbon dioxide formed by potash absorption.

(The question of the requisite strength of mixture has already



## Fuel Testing

been dealt with under the heading of "Combustion and Explosion Methods of Analysis," to which reference should be made.)

Approximately the correct amount of oxygen is introduced into M and transferred to E, and the total pressure of the mixed gases is then measured. The gases are transferred to H and T<sub>2</sub> is closed. The pressure in H is diminished to about one-half an atmosphere by lowering the mercury reservoir. The mixture is ignited by means of a "break spark." The gases are again transferred to E and the pressure is measured. The amount of carbon dioxide formed is estimated by KOH absorption as previously described. From the figures for the contraction after explosion and the absorption with KOH the amounts of hydrogen and methane are calculated.

## Preparation and Storage of Reagents

*Potassium Hydroxide.*—KOH. 1 lb. of stick potash (not alcoholic) dissolved in 500 ml. of water (distilled). Store in rubber-stoppered bottle.

*Pyrogallic Acid.*—1 oz. dissolved in 100 ml. of distilled water. Keep in stoppered bottle.

*Bromine Water.*—Make a 10 per cent. solution of KBr in distilled water; add bromine until the solution is a lemon-yellow colour. Keep in a stoppered bottle.

*Ammoniacal Cuprous Chloride.*—Dissolve 7 gm. of ammonium chloride in 80 c.c. of distilled water; add 23 gm. of cuprous chloride. The cuprous chloride should be pure and nearly white in colour. Add 15 ml. of 0.880 ammonia. On standing, and with an occasional shake, all the solid should dissolve; if it does not do so, add a few ml. of ammonia and allow to stand for a further period. The solution, when correctly prepared, should smell only faintly of ammonia; if it smells strongly of ammonia, add a further 1 gm. of cuprous chloride. The solution should be stored in a well-stoppered bottle. It readily absorbs oxygen from the atmosphere, and the bottle should therefore never be left open. To test it for activity, take a few ml. and add dilute sulphuric acid; there should be a copious white precipitate formed immediately. Such a solution retains its efficiency for a week or ten days only, and should then be replaced.

*Note.*—Alternatively, a mixture of solid ammonium chloride and solid cuprous chloride may be made up and stored in a well-stoppered bottle. When an analysis is being made, about 5 gm. of the mixture are taken in a test tube provided with a rubber cork, about 15 ml. water are added, and then 0.880 ammonia drop by drop, until the solid material in the tube is practically all dissolved. By this means it is absolutely certain that the solution is fresh, as no more than will suffice for one or two analyses is made up at a time.

## Bone and Newitt Gas Analysis Apparatus

*Oxygen.*—Gently heat potassium permanganate \* in a hard glass tube, pass the gas over caustic potash and collect in a glass holder, and store over a 1 per cent. KOH solution.

*Electrolytic Gas.*—Prepare from a solution of re-crystallised barium hydroxide in distilled water. Collect in test tubes over mercury, and have a number of such tubes always ready for use. From time to time test a sample by suitable dilution with oxygen and explosion in the vessel H. The final pressure of gas should exactly equal the pressure of diluent gas added.

*Dilute Sulphuric Acid.*—1 per cent. by volume in distilled water ; 2 litres should be prepared at a time, as previously described.

### Cleaning the Apparatus

It is very essential to keep the apparatus clean, and in particular free from grease. Beginners usually use too much grease to lubricate the taps, and consequently grease gets drawn into the apparatus and gives rise to all sorts of trouble. Read carefully the instructions on "Care of Glass Taps."

Once every few weeks, according to the use of the apparatus, it will require a thorough cleaning ; the following method is recommended :

Take down the measuring vessel and the explosion tube and clean them thoroughly with chromic acid cleaning mixture, paying particular attention to the points where the capillary tubes join the tap barrels, and wash thoroughly with distilled water. The explosion tube may be cleaned from time to time, without taking it down, by burning out traces of grease : this may be accomplished by making several explosions of electrolytic gas diluted with  $2\frac{1}{2}$  volumes of oxygen which has been stored over a 1 per cent. solution of caustic potash. The residual gas after the explosions should be tested for the presence of carbon dioxide, and if none is detected, the vessel is free from organic matter.

The mercury in C will remain clean for very long periods.

A loose stopper should be fitted to the mercury reservoir of the explosion vessel to keep dust out.

It is useful to make a light wood or cardboard cover to fit J ; when the apparatus is not in use dust will be kept out. The surface of the mercury in J may be cleaned by "sweeping" with moist filter paper.

Mercury will gradually collect in the trap K. It should be removed from time to time by means of the tap, washed and returned

\* The objection to the use of oxygen drawn from a cylinder is that if it has been made by the electrolytic process, there may be traces of hydrogen present.

## Fuel Testing

to J. K is self-cleaning as, during analyses, there is a continual stream of water from B passing through it.

Less thorough cleansing may be carried out without dismantling the apparatus by washing the interior with (a) alcohol, to remove water, (b) chloroform, to dissolve grease, (c) alcohol, to remove the chloroform, and, finally, (d) dilute sulphuric acid (several times) to wash out the last traces of alcohol.

## Recording Gas Analysis Observations

It is recommended that all observations made during a gas analysis be recorded in tabular form as follows :

	Constant Volume Mark.	Pressure Reading.	Difference.	T° C.	Per Cent.
Gas . . .	200	356.2	156.2	15.8	100.00
KOH . . .	200	274.7	81.5		CO <sub>2</sub> 52.2
Pyro . . .	200	271.6	3.1	15.9	O <sub>2</sub> 2.0
Br . . .	200	265.8	5.8		C <sub>n</sub> H <sub>m</sub> 3.7
Cu <sub>2</sub> Cl <sub>2</sub> . . .	200	249.4	16.4	15.8	CO 10.5
Gas for explosion	200	249.4	49.4	15.8	
Oxygen . . .	200	550.0	350.0		
Mixture . . .	200	599.3	399.3		
After explosion .	200	509.9	89.4		
After KOH . . .	200	467.4	42.5	15.8	

It will be noted that where the gas for analysis or for explosion is to be measured, the figure in the "difference" column is the difference between the "constant volume" or "vacuum" reading and the "pressure" reading. When, however, it is a question of determining the amount of absorption or the contraction after explosion, the "difference" is the difference between successive "pressure" readings.

$$\text{CH}_4 = \frac{42.5 \times 100}{156.2} = 27.2 \text{ per cent.}$$

$$\text{H}_2 = \frac{2}{3}(89.4 - 2 \times 42.5) \times \frac{100}{156.2} = 1.9 \text{ per cent.}$$

The analysis is therefore :

CO <sub>2</sub>	52.2 per cent.	
O <sub>2</sub>	2.0	,, ,,
C <sub>n</sub> H <sub>m</sub>	3.7	,, ,,
CO	10.5	,, ,,
CH <sub>4</sub>	27.2	,, ,,
H <sub>2</sub>	1.9	,, ,,
N <sub>2</sub>	2.5	,, ,, (by difference).

## Treatment of Gas Residues

### TREATMENT OF GAS RESIDUES : FRACTIONATION BY LIQUID AIR

To obtain more information than is afforded by preferential combustion of the hydrogen, followed by explosion analysis of the hydrocarbons with oxygen, fractionation of the residue by means of liquid air may be carried out.

The application of this method is fully described by Burrell, Seibert and Robertson.<sup>5</sup> The description which follows is applied particularly to the residues left after the absorption analysis of gases, i.e. to gases containing hydrogen, methane and higher hydrocarbons and nitrogen.

The gas is liquefied at the temperature of liquid air ( $-185^{\circ}\text{C}.$ ), and certain gases which are not liquefied (nitrogen and hydrogen), or which exert an appreciable vapour pressure at this temperature (mainly methane), are removed by evacuation. The liquid residue is refractionated at a temperature of from  $-150^{\circ}$  to  $-140^{\circ}\text{C}.$ , and again evacuated, whereby ethane plus some propane is pumped off ; while by evacuation at from  $-135^{\circ}$  to  $-120^{\circ}\text{C}.$ , propane is removed, and at about  $-78^{\circ}\text{C}.$ , butane is pumped out.

The apparatus described was used by W. E. Stockings and the Author for the fractionation of natural gas ; it has also been employed for the examination of hydrogen-hydrocarbon-nitrogen residues from the low temperature carbonisation of brown coals.

The essential parts of the apparatus are illustrated in Fig. 31, and include a measuring and gas-collecting system in the form of two graduated gas holders A and B (the first of 750 or 800 ml. capacity, and the second of 100 to 250 ml., depending on the volume of residue and of the fractions to be measured), each provided with a barometer tube closed at the top by a tap, a pumping arrangement (gas holder A is adapted to this purpose, as will be described later), and a liquefaction system consisting of three small bulbs  $C_1$ ,  $C_2$  and  $C_3$ .

The lower end of gas holder A is fitted with a tap, below which is a length of 6 or 8 in. of heavy-walled glass tubing which passes through an india-rubber cork to the bottom of a stout glass filter flask which acts as a mercury reservoir. To the side tube of the flask is joined a three-way tap, one branch of which is connected to a supply of water pressure under, and the other to a filter pump. Pressure or suction can thus be applied to the mercury in the flask, which is thus forced up into or withdrawn from A as required ; consequently A may be used as a Töpler pump for the evacuation of gas from the liquefaction system C.

A is connected to B by capillary tubing, a three-way tap  $D^1$  being fused in at the middle. The third limb of this tap is connected through a *small* phosphorus pentoxide tube to the liquefaction system.

## Fuel Testing

This tube serves to ensure that the gas within the apparatus is kept dry; it also acts as a trap to catch any small globules of mercury which may by inadvertence be allowed to escape from A or B.

Each of the bulbs C consists of a small glass flask about 10 ml. capacity, provided with an inlet tube, and a long exit tube coiled round the neck; both inlet and exit tube are fitted with single-way taps E. The liquefaction system consists of three such bulbs connected in a triangle, the gas inlet from between A and B being joined to a T-piece between C<sup>1</sup> and C<sup>2</sup>. Manometers are connected to T-pieces between C<sup>1</sup> and C<sup>3</sup>, and between C<sup>2</sup> and C<sup>3</sup>, a three-way tap

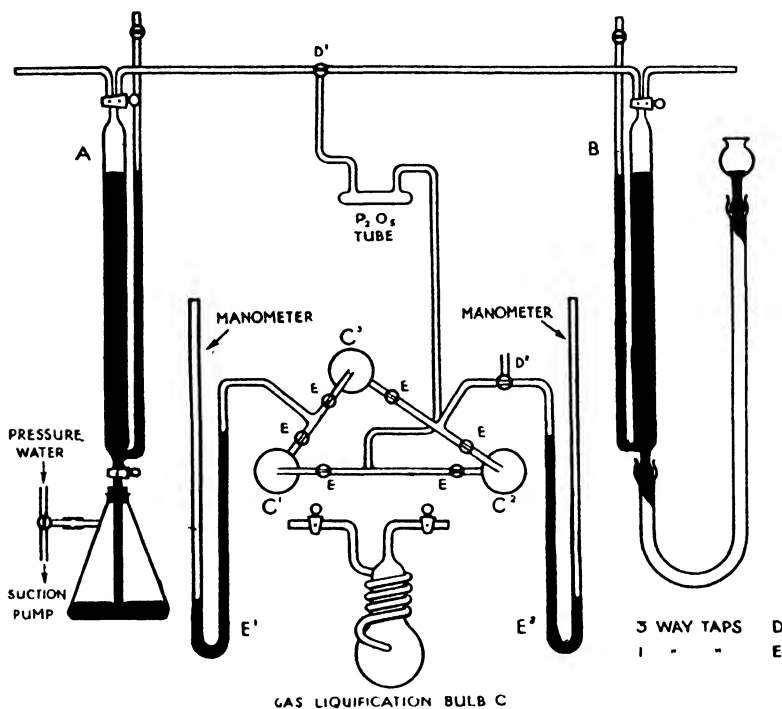

FIG. 31.—Apparatus for Fractionation of Gases by Liquid Air.

D<sup>2</sup> being interposed in the connection to the manometer E<sup>2</sup>: this tap serves to connect a pump for evacuating the system. Normally, two bulbs only, viz. C<sup>1</sup> and C<sup>2</sup>, are employed in the process of liquefaction and evacuation, the third bulb C<sup>3</sup> serves to give extra capacity to the system in case the residue handled contains much non liquefiable gas, and it can also be used to store gas in the liquid condition pending further treatment.

Before starting an experiment, the gas holders A and B are filled with dry mercury, the rest of the apparatus is evacuated through D<sup>2</sup> by a Hyvac or other suitable pump, and several times filled with air dried by passage over phosphorus pentoxide to remove

## Treatment of Gas Residues

any traces of moisture from the interior. The liquefaction system is then finally completely evacuated.

The gas residue, dried by passage over calcium chloride and phosphorus pentoxide, is introduced into and measured in either B or A, according to the volume dealt with. The bulbs  $C^1$  and  $C^2$  are surrounded by liquid air, and the gas is slowly passed into  $C^1$ , where liquefaction of all constituents, save the nitrogen and hydrogen, takes place.  $C^1$  is repeatedly evacuated, using A as a pump, all gas pumped off (consisting of hydrogen, nitrogen and methane) is transferred to  $C^2$ . When no further gas is obtained from  $C^1$  by evacuation, the taps in the inlet and exit tubes are closed, and the liquefied residue (consisting of a trace of  $CH_4$  and all the higher homologues) is retained in a liquid state while the distillate in  $C^2$  is dealt with.

$C^2$  is repeatedly evacuated, the gas pumped off being transferred to B and measured, after which this fraction is run off into a storage holder, preferably over mercury, until required for analysis.

Since the gas pumped off from  $C^2$  was originally a distillate, there should be no residue left after this second thorough evacuation. Should any residue be found, which is proved by removing the liquid air from  $C^2$  and noting if the manometer  $E^2$  falls, it must be transferred to and added to the liquid in  $C^1$ .

The residue in  $C^1$  (consisting of hydrocarbons higher than methane) should next be fractionated at from  $-150^\circ$  to  $-140^\circ$  C. The cooling bath is prepared by half-filling the cooling vessel with a suitable organic liquid and stirring with a test tube of liquid air until the requisite temperature (determined by means of a pentane thermometer) is obtained. The liquid suggested in the paper referred to is "wild" gasoline, which contains large quantities of liquid propane and (especially) butane, and which remains liquid at  $-150^\circ$  C. Stockings and the Author used pure pentane which was found partly to solidify at about  $-140^\circ$  C., and this consequently was the lowest temperature which could be employed for the second fractionation.  $C^1$  is cooled in a bath of this nature, and repeatedly evacuated, the gas being transferred to  $C^2$  and condensed there in liquid air. The temperature of the cooling bath should be carefully watched, and during fractionation may be allowed to rise to  $-125^\circ$  C. but not higher. The distillate thus obtained consists of a mixture of ethane and propane, and the residue of propane plus higher hydrocarbons. By suitable refractionation of both distillate and residue over narrow temperature ranges, the individual hydrocarbons may be isolated. For complete details, the memoir quoted should be consulted.

In some cases a less complicated procedure may be adopted. As an example, it was required to determine whether free hydrogen

## Fuel Testing

was evolved by the decomposition at 400° C. of a brown coal. The gas from the coal gave 12.9 per cent. of residue, whose  $C/A$  ratio was 1.77, indicating an effective composition between methane and ethane.

180 ml. of this residue were liquefied as described above, and by one evacuation a 45 ml. fraction was drawn off, giving 26.95 per cent. of methane and 39.15 per cent. of hydrogen. The liquefied residue was evacuated six times at  $-185^{\circ}$  C., by which process all distillate was pumped off, giving a 98 ml. distillate containing 83.2 per cent. of methane and 3.07 per cent. of hydrogen. The residue when re-evaporated amounted to 36 ml. of a gas containing a hydrocarbon mixture of effective composition, ethane 36.0 per cent. and propane 48.7 per cent.

Hence, the residue contained 11.46 per cent. of free hydrogen, which was equivalent to 1.48 per cent. on the original gas. Moreover, the presence of saturated hydrocarbons at least as high as propane was conclusively proved, and it is legitimate to infer that further fractionation would have shown the presence of butane, and probably also pentane.

## MISCELLANEOUS DETERMINATIONS

### Separation and Determination of Unsaturated Hydrocarbons in the Gases from the Carbonisation of Coal

A. B. Manning, J. G. King and F. S. Sinnatt.<sup>6</sup> The volume of sample required is about 10 cu. ft. Condensable vapours are first removed by scrubbing with oil; the unsaturated gases are then converted to bromides by bubbling the scrubbed sample through bromine. Any unsaturated gases dissolved in the oil are recovered by distilling the oil, converted to bromides and the bromides are added to the main bulk. The bromides are collected and weighed, and are then distilled under reduced pressure (20 mm.) to give fractions (*a*) up to 80° C., (*b*) from 80° to 130° C., and (*c*) residue. Fraction (*a*), consisting of from 80 to 90 per cent. of the whole, contains all the ethylene and propylene dibromides, with possibly traces of the dibromides of higher hydrocarbons which have escaped the oil scrubber; (*b*), which consists of about 6 per cent. of the whole, contains some butylene dibromide *plus* bromine derivatives of higher olefines, benzene and toluene (if present). The residue (*c*) contains acetylene tetrabromide, butadiene tetrabromide and smaller quantities of unidentified compounds.

The olefines are regenerated from a known weight of the bromine compounds by the action of a zinc-copper couple; the gas is measured and analysed. (*a*) The total percentage of unsaturated

## Miscellaneous Determinations

hydrocarbons is determined by absorption in fuming sulphuric acid or bromine water ; (b) a second part of the gas is burned completely over copper oxide at 700° C. and the CO<sub>2</sub> is determined ; and (c) another portion is treated with successive amounts of 87 per cent. sulphuric acid (S.G. 1.800), 2 ml. being used for each treatment, which occupies exactly 5 minutes. Olefines higher than ethylene are completely absorbed in 20 minutes. After this period, the absorption in 5 minutes becomes small and constant, and is due to the absorption of ethylene ; determination of the rate of absorption enables a correction to be made for the ethylene absorbed during the first 20 minutes. The middle fraction, which consists principally of butylene dibromide, is similarly treated.

From the data thus obtained, the relative proportions of the olefine hydrocarbons may be calculated.

For details of the method and examples of the results obtained, the original paper should be consulted.

## Ammonia in Coal-Gas or Coke-Oven Gas

The general method is to bubble a metered quantity of gas through a known volume of standard sulphuric acid, the excess acid being titrated with standard alkali. The quantity to be determined will depend on the position at which the sample of gas is withdrawn, i.e. before or after the plant for the recovery of ammonia. Alwyne Meade <sup>7</sup> states that in gasworks practice, coal-gas contains from 200 to 300 grains per 100 cu. ft. (or, on an average, 0.75 per cent. by volume), when leaving the condensers, and from nil to 1.5 grains per 100 cu. ft. when leaving the scrubbers. The gas leaving the condensers also contains appreciable quantities of tar-fog.

The quantity of gas and the volume and strength of the standard acid must be decided according to the amount of ammonia in the gas : 1 grain = 0.0648 gm., and 1 ml. N/10 acid is equivalent to 0.2625 grain of ammonia, or 100 cu. ft. of unscrubbed gas are equivalent to about 1 litre N/10 acid, while 100 cu. ft. of scrubbed gas may contain ammonia equivalent to about 5.4 ml. of N/10 acid.

To carry out the test, a suitable quantity of the gas is passed through a measured volume of standard acid contained in a bubbler which ensures good contact between the gas and liquid. It is not advisable to try to filter out tar-fog ; glass wool has been used, but the results were found to be low ; if there is trouble due to discoloration of the acid on account of tar-fog, the indicator used in titrating the excess acid should be fluorescein. The end-point is the disappearance of fluorescence, which is best observed when the vessel is stood on black paper.<sup>8</sup>



## Fuel Testing

### Benzol in Coal-Gas or Coke-Oven Gas

Müller<sup>9</sup> (*Journ. Gasbeleucht*, 1898, 11, p. 433) recommended absorption in paraffin oil cooled in a freezing mixture of ice and salt, the benzene being determined by the increase in weight of the absorbing vessels. A metered quantity of gas is passed through a tube containing calcium chloride to dry it, then through three or four bubblers containing paraffin, of S.G. 0.88 to 0.89 and boiling at about 300° C., which are arranged in series and standing in a bath containing ice and salt. The rate of passage of gas should be about 2 ml. per minute and all joints should be made glass-to-glass, the minimum surface of rubber tubing being exposed to benzene vapour.

An alternative and better method<sup>10</sup> is to freeze out the benzene vapour in one of the little condensation tubes C of Fig. 31, in a mixture of solid carbon dioxide with ether or acetone; at the temperature thus produced (about -80° C.), the vapour pressure of benzene is negligible. The quantity of gas which must be passed will depend on the amount of benzene vapour in it and must be determined by experiment. Before entering the condensation bulb the gas must be dried over calcium chloride.

### Naphthalene in Coal-Gas or Coke-Oven Gas<sup>11</sup>

The gas is passed through three bubblers containing a nearly saturated solution of picric acid in water, the first bottle containing about 100 ml. and the other two about 50 ml. The gas is first bubbled through a solution of citric acid to remove ammonia and passed through the apparatus at from 0.5 to 1.0 cu. ft. per hour. Nearly all the naphthalene is absorbed in the first bottle and converted to picrate which, however, suffers partial hydrolysis. The gas must not come into contact with rubber before entering the picric acid, since rubber absorbs naphthalene; to avoid this, standard ground-glass joints should be employed in assembling the apparatus.

To convert the whole of the naphthalene into picrate, the contents of the bottles are washed with the minimum quantity of water into a narrow-necked bottle which should be almost completely filled; the bottle is evacuated and the contents are heated on a water-bath until the whole of the precipitate has risen to the surface, leaving the liquid quite clear. The bottle is then cooled and shaken at intervals to wash down any naphthalene which has sublimed into the upper portion. The volume of the cold liquid is measured, the precipitate is filtered off through a *dry* filter paper, the first few ml. are rejected and 100 ml. of the filtrate are titrated with N/10 alkali, using phenolphthalein, lacmoid or methyl orange as indicator.

## Miscellaneous Determinations

1 ml. of N/10 alkali corresponds to 0.0229 gm. of picric acid or to 0.0128 gm. or 0.1975 grain of naphthalene.

## Hydrogen Sulphide in Coal-Gas or Coke-Oven Gas

The method is the same as that described on page 99.

### BIBLIOGRAPHY

<sup>1</sup> University of Illinois, Engineering Experiment Station, Circular No. 7, April, 1918.

<sup>2</sup> W. A. Bone and D. S. Jordan, *Journ. Chem. Soc.*, 1901, **79**, pp. 1044-7.

<sup>3</sup> J. G. King and L. J. Edgcombe, Fuel Research Board, Technical Paper No. 33, 1931.

<sup>4</sup> R. V. Wheeler, *Gas Journ.*, 1922, **157**, p. 702.

<sup>5</sup> Burrell, Seibert and Robertson, U.S. Bureau of Mines, Technical Paper No. 104, 1915.

<sup>6</sup> A. B. Manning, J. G. King and F. S. Sinnatt, Fuel Research Board, Technical Paper No. 19, 1928.

<sup>7</sup> Alwyne Meade, "Modern Gasworks Practice," 1921, pp. 506 and 570.

<sup>8</sup> G. Lunge, "Technical Gas Analysis," revised by H. R. Ambler, 1934, p. 288.

<sup>9</sup> Müller, *J. Gasbel.*, 1898, **11**, p. 433. See also Berthold, *Glückauf*, 1921, **57**, p. 508.

<sup>10</sup> G. Lunge, *op. cit.*, p. 269.

<sup>11</sup> G. Lunge, *op. cit.*, p. 270.

CHAPTER XI

THE CALORIFIC VALUE OF GASES

SINCE the calorific values of gases are expressed on a volumetric basis, it is necessary to define the standard conditions of temperature and pressure to which the volume is referred. For scientific purposes, calorific values of gases are generally expressed as K.C.U.s. per cubic metre at 0° C. and 760 mm. (N.T.P.), but in engineering practice, in Great Britain, the standard conditions are 30 in. total pressure and 60° F., the gas being saturated with water vapour (S.T.P.). Where, however, the calorific value of partially dried coal-gas is quoted, the conditions assumed are 30 in. total pressure and 60° F., the degree of saturation being that which actually obtains. Hence, unless when giving a calorific value, the conditions under which the volume is measured are clearly stated, confusion will result.

CALCULATION OF CALORIFIC VALUE

Since fuel gases consist of mechanical mixtures of a comparatively limited number of constituents, their calorific values may be calcu-

TABLE XX

HEATS OF COMBUSTION OF GASES

	K.C.U.s. per Gm. Molecule at N.T.P.		B.Th.U.s. per cu. ft.			
			At N.T.P.		At 30 in. and 60° F. Saturated.	
	Gross.	Net.	Gross.	Net.	Gross.	Net.
Carbon monoxide	67.9	67.9	341.1	341.1	318	318
Hydrogen . . . . .	68.4	57.8	343.2	289.9	320	270
Methane . . . . .	212.6	191.8	1067.2	961.2	995	895
Ethane . . . . .	369.7	337.9	1855.6	1696	1730	1580
Ethylene . . . . .	333.4	312.2	1673.3	1566	1560	1460
Propylene . . . . .	491.3	459.5	2467.0	2307	2300	2150
Benzene . . . . .	798.8	767.0	4011.5	3950	3740	3590
Hydrogen sulphide	134.6	112.4	675.7	564.1	630	580

## Calculation of Calorific Value

lated with fair accuracy provided the composition of the mixture and the heats of combustion of the constituents are known. The values for the heats of combustion of the usual constituents of fuel gases are given in Table XX.

As an example, the calorific value of the lignite gas whose composition is given on page 102 may be calculated:—

Constituent.	Percentage by Volume.	Heat of Combustion at S.T.P.	Product. B.Th.U.s.
CO <sub>2</sub> . .	24.05	—	—
CO . .	18.75	318	5969
C <sub>n</sub> H <sub>m</sub> . .	2.30	2300	5290 (assumed to be propylene)
CH <sub>4</sub> . .	28.50	995	28350
H <sub>2</sub> . .	22.55	320	7216
N <sub>2</sub> . .	3.85	—	—
		Total .	46825

The calorific value is therefore  $\frac{46825}{100} = 468.25$  B.Th.U.s. per cu. ft. at S.T.P., which would be returned as 468 B.Th.U.s., since it is never justifiable to report a calculated calorific value to a fraction of a unit; in fact, it would be preferable to round the result off to the nearest 5 units and call the result 470 B.Th.U.s.

The main source of error in calculating calorific values is the uncertainty of the nature of the unsaturated and (sometimes) of the complexity of the saturated hydrocarbons. It is commonly assumed that the unsaturated hydrocarbons have the same heat of combustion as propylene (C<sub>3</sub>H<sub>6</sub>), and this has been done in the example. The calculated results for the calorific value of coal-gas, producer-gas, and blue water-gas usually agree with those directly determined to within 2 or 3 per cent., but if the percentage of unsaturated hydrocarbons is high (as in carburetted water-gas or oil-gas), the agreement may be much less satisfactory. Moreover, in dealing with gases from the low temperature carbonisation of coal, although the results of the explosion analysis are usually returned in terms of methane and hydrogen, the gas may contain higher hydrocarbons. In the example the gas might have contained CH<sub>4</sub> = 18.50, C<sub>2</sub>H<sub>6</sub> = 5.00 and H<sub>2</sub> = 27.55, instead of CH<sub>4</sub> = 28.5 and H<sub>2</sub> = 22.55 as given in the analysis. Had this been so, the contribution of these constituents to the calorific value would be 358.7 B.Th.U.s. per cu. ft. instead of 355.2; which shows that the calorific value of a gaseous

## Fuel Testing

mixture calculated from the analysis should not be returned to anything closer than the nearest 5 units, the impression of greater accuracy conveyed by giving the result to the nearest unit being misleading.

C. G. Hyde and F. E. Mills<sup>1</sup> have shown from the comparison of the calorific value directly determined and calculated from the analyses of 34 gases (whose calorific values varied from 410 to 604 B.Th.U.s. per cu. ft.) that the error introduced by the assumption that the unsaturated hydrocarbons have the same heat of combustion as propylene, may be from + 2 to - 21 B.Th.U.s. per cu. ft., with an average of - 11.8, and that to equalise the calorimetric and calculated results, the unsaturated hydrocarbons must be assumed to have heats of combustion ranging from 2286 to 3333 B.Th.U.s. per cu. ft. at S.T.P., with an average of 2783, or intermediate between propylene and butylene.

### THE DIRECT MEASUREMENT OF CALORIFIC VALUE

The usual method is to burn the gas at a constant known rate, in a vessel, under such conditions that the heat produced is absorbed in water which also flows at a known constant rate. Knowing the volume of gas burned in a given time, the volume (and therefore the weight) of water passed and the average rise in temperature of the water, the calorific value of the gas may be calculated.

If the results of a calorimetric determination are to be of any value at all, the following conditions must be fulfilled : (i) *Combustion must be complete* ; this is secured by burning the gas with a suitable excess of air, generally about 40 per cent. in excess of that theoretically required for complete combustion. The correct rate of flow of gas may be ascertained as follows. The flow of gas through the calorimeter is gradually increased until an unpleasant odour is noted in the products of combustion ; this shows that combustion is incomplete, and 70 per cent. of this rate of flow is adopted as the "normal rate" for the calorimeter. An alternative and more accurate method is gradually to increase the rate of flow of gas and to observe the reading of the thermometer in the water leaving the calorimeter. As long as combustion is complete, the temperature of the exit water will rise concomitantly with the increase in the rate of flow of the gas ; as soon as combustion ceases to be complete, the temperature shown by the thermometer in the exit water will begin to fall. Having observed the rate of flow of gas when this takes place, 70 per cent. of this rate is taken as the "normal rate." (ii) *The heat of combustion must be completely transferred to the water and there must be no augmentation or depletion of the heat produced by*

## Direct Measurement of Calorific Value

*the combustion of the gas.* Transfer of heat is secured by counter-current flow of the products of combustion and the water and by breaking up the products into fine streams in passages cooled by the water; this is a question of the design of the calorimeter. Loss of heat from the exterior of the apparatus may take place by radiation and convection; this is minimised by careful lagging and by providing a brightly polished metal jacket on the outside of the calorimeter.

Since the calorimeter cannot be operated so that the heat leaving the system in the products of combustion is precisely the same as that entering in the gas and air, there is inevitably loss or gain of heat owing to variation in the sensible and latent heat carried away in the waste gases, and this must be allowed for and a correction applied to the observed calorific value. In practice, the best that can be done is to ensure that the air/gas ratio is fixed so that the difference in the heat content of the gas and air and the products may be determined and allowed for. An empirical correction is to add to the observed calorific value  $2/5 \times$  the excess temperature (in degrees F.) of the products of combustion over that of the air in the room, while, in addition, the factor used to convert K.C.U.s.\* to B.Th.U.s. (3.992 instead of 3.97) includes a correction for difference in exposed mercury column of the thermometers in the water entering and leaving the calorimeter, *plus* an allowance for the latent heat of the water vapours in the waste products. With gas of 560 B.Th.U.s. per cu. ft., Hyde and Mills (*op. cit.*) found that over a year, the difference between the corrections deduced by calculation and the empirical formula ranged from  $-1.8$  to  $+2.5$  B.Th.U.s. (with an average of  $-0.025$ ) in individual tests from a series of 168, and for gas of declared calorific value 500 B.Th.U.s. per cu. ft. on 100 observations during 5 months, the difference was from  $-2.9$  to  $+1.2$  B.Th.U.s. and averaged  $-0.75$ .

Considerable unauthorised gain of heat may take place if the temperature of the water supplied to the calorimeter is considerably below that of the air in the room, and it is therefore specified in the General Notification of the Gas Referees that the temperature of the water entering the calorimeter shall not be more than  $5^{\circ}$  C. below that of the air in the room. Hyde and Mills quote results which show that with an increase in the temperature difference (air-water) of approximately  $10^{\circ}$  C. a change in the apparent calorific value of from 8 to 12 B.Th.U.s. may be expected.

\* An example of the calculation of the correction is given on p. 184.

## Fuel Testing

Calculation of the correction for loss of heat in the waste products of combustion ;—

Coal-gas. 100 Mols.		Mols. Air Reqd.	Products.		
			CO <sub>2</sub> .	H <sub>2</sub> O.	N <sub>2</sub> .
CO <sub>2</sub>	3.0	—	3.0	—	—
CO	9.0	21.4	9.0	—	—
C <sub>2</sub> H <sub>6</sub>	3.0	85.7	12.0	12.0	—
CH <sub>4</sub>	25.0	238.0	25.0	50.0	—
H <sub>2</sub>	53.6	127.6	—	53.6	—
O <sub>2</sub>	0.4	—1.9	—	—	—
N <sub>2</sub>	6.0	—	—	—	6.0
					372.0 from air
		470.8	49.0	115.6	378

If the air/gas ratio is 7 : 1, there will be in addition  $229 \times 0.21 = 48.1$  mols. oxygen, and a further 180.9 mols. nitrogen in the waste products from 100 mols. coal-gas, and the products will be

CO<sub>2</sub>—49.0, H<sub>2</sub>O—115.6, O<sub>2</sub>—48.1 and N<sub>2</sub>—558.9 mols.

The gas being measured in a wet meter will be saturated with water vapour while the air will be approximately 60 per cent. saturated. Therefore, since the vapour tension of water at 60° F. is 13.2 mm. Hg, or 0.52 in., and if the total pressure is 30 in., the mols of water vapour entering the system will be : in the gas,  $\frac{0.52 \times 100}{30 - 0.52} = 1.76$ , and with the air,  $1.76 \times 7 \times 0.6 = 7.40$ .

The wet products from 100 mols. of dry gas will therefore consist of

CO <sub>2</sub>	.	.	.	.	49.0
H <sub>2</sub> O	.	.	.	.	124.8
O <sub>2</sub>	.	.	.	.	48.1
N <sub>2</sub>	.	.	.	.	558.9

Excluding water vapour, there will be 656.0 mols. of dry products, associated with  $6.56 \times 1.76$ , or 11.6 mols. water vapour. Hence the gaseous effluent, will consist of

CO <sub>2</sub>	.	.	.	.	49.0
H <sub>2</sub> O	.	.	.	.	11.6
O <sub>2</sub>	.	.	.	.	48.1
N <sub>2</sub>	.	.	.	.	558.9 mols.

The sensible heat above 32° F. at 60° F. will be

CO <sub>2</sub>	.	.	.	49	$\times 242 =$	11,850 B.Th.U.s.
O <sub>2</sub>	.	.	.	48.1	$\times 197 =$	9,480 "
N <sub>2</sub>	.	.	.	558.9	$\times 200 =$	117,800 "
H <sub>2</sub> O	.	.	.	11.6	$\times 222 =$	2,570 "

Total = 141,700 "

## Apparatus Used in Gas Calorimetry

or, per cu. ft. of gas measured at S.T.P. =  $\frac{141,700}{100 \times 385} = 3.69$  B.Th.Us., or per degree F. =  $\frac{3.69}{28} = 0.132$  B.Th.Us. The quantity of water vapour carried out by the waste gases will depend on the temperature, and therefore the amount of latent heat of condensation will also vary. Now, over the range from (say) 55° to 68° F. the variation in the vapour tension of water varies by 0.02 in. of mercury per degree F. Hence, per 656 mols. of dry products, there will be a variation of  $\frac{100 \times 0.02 \times 6.56}{29.48} = 0.45$  mols. water vapour. The latent heat carried away will therefore vary by  $0.45 \times 19,000$  or 8,550 B.Th.Us. per degree F., or per cu. ft. at S.T.P. by  $\frac{8550}{100 \times 385} = 0.222$  B.Th.Us. The total correction therefore amounts to 0.354 B.Th.Us. per degree, which is close to the  $\frac{2}{5}$  already mentioned.

In addition, there will be a constant loss of heat owing to the fact that whereas 9.16 mols. water vapour entered the system, 11.6 mols. leave it. The latent heat of condensation of the 2.44 mols. will be 46,300 B.Th.Us., or 1.20 B.Th.Us. per cu. ft. of gas at S.T.P. This is allowed for, and also the fact that the length of exposed mercury column in the thermometers in the inlet and exit water to the calorimeter is different, by using the factor 3.992 instead of 3.97 to convert the heat from K.C.Us. to B.Th.Us.

### APPARATUS USED IN GAS CALORIMETRY

A flow-type gas calorimeter embodies the following parts :

- (i) Arrangements for the supply of gas and water at constant rates.
- (ii) Apparatus for measuring the gas and water.
- (iii) A burner at which the gas is burned and a heat-exchange system for the transmission of the heat of combustion to the water.

The chief differences between the various makes of gas calorimeter lie in the arrangements for burning the gas and in the heat transmitting system ; the apparatus described and illustrated in this chapter is the Boys non-recording gas calorimeter which was originally designed on behalf of the Metropolitan Gas Referees and prescribed by them in 1906 for testing the calorific value of illuminating gas.

(i) *The Water Supply*.—This is preferably drawn from a tank within the laboratory or testing room in order that the temperature may be nearly that of the room in which the tests are made. The temperature of the water should be not more than 5° C. below the temperature of the air in the room, and it may be necessary to instal a temperature-regulating device in the tank to ensure that this requirement is met. Water drawn directly from the main or from a tank on the roof of the building is liable to be colder than the air, especially in winter, and it has already been shown that if this is so the apparent calorific value may be seriously high.



## Fuel Testing

The water is delivered to the calorimeter vessel via a constant-level device which consists of a small semi-cylindrical box divided into two compartments by a vertical weir. On one side of the weir are two tubes, one for the supply of water to the constant-head vessel, the other delivering water to the water system of the calorimeter; the water supply is adjusted so that there is a continuous spill over the weir, the overflow being run away by a third tube to the sink. The water is thus supplied at constant head, which should be 3 or 4 ft. above the inlet to the calorimeter.

(ii) *The Flow of Gas.*—This is maintained steady by means of a governor, usually of the “balanced” type, which is illustrated diagrammatically in Fig. 32. The governor consists of a bell of

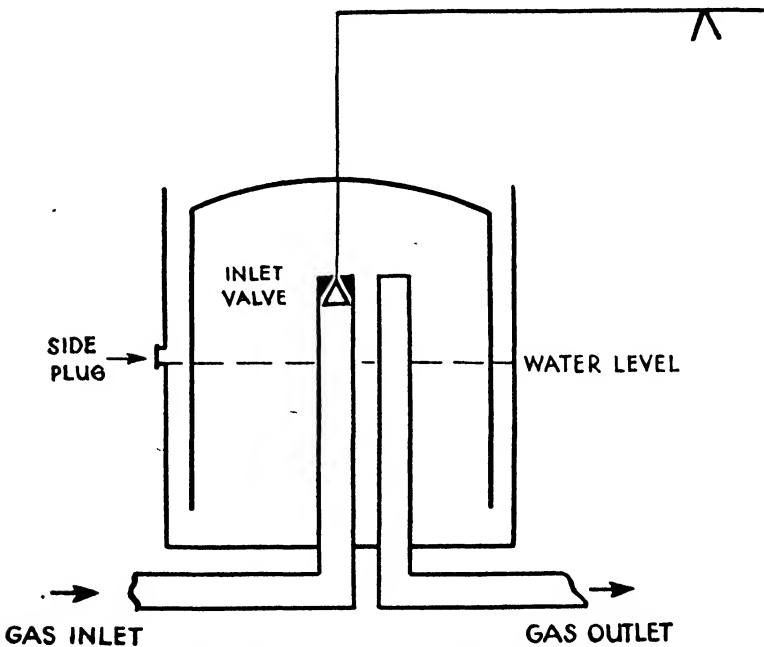

FIG. 32.—The Balanced Gas Governor.

thin sheet metal suspended from one arm of a lever, and balanced by a counter-weight at the other end of the lever. The bell dips into a cylindrical vessel half-filled with water which forms a seal, and carries from its centre a conical valve which controls the passage of gas into the governor from the inlet pipe. An increase in pressure within the bell causes it to rise, partly or completely closing the inlet pipe, while a reduction in pressure causes the bell to fall, allowing the gas to flow more freely. By altering the balance weight, the clearance between the conical valve and its seat is changed, and the sensitivity of the governor is altered. The level of water in the governor is adjusted by removing the side-plug,

## The Boys Non-Recording Gas Calorimeter

opening the inlet and outlet cocks (when supplied) to the atmosphere, and pouring water into the seal vessel until it just flows out from the orifice for the plug, which is then replaced.

The gas is measured after passing the governor in a wet meter whose capacity is usually one-tenth or one-twelfth of a cubic foot per revolution. To ensure accuracy, the meter must be set exactly level, and the water in it must be accurately adjusted to the marks on the water-gauge at the side. Between the governor and the meter, a water manometer is introduced so that the supply pressure of the gas to the meter may be determined. The manometer may consist of a simple U-tube provided with a scale reading in tenths of an inch.

(iii) *Measurement of the Water.*—The water flowing through the calorimeter is collected in a 2400 ml. cylinder, the lower portion of which is of larger diameter than the upper, and graduated every 10 ml. over the range from 1600 to 2400. Alternatively, the water may be weighed in a suitable vessel, allowance being made for buoyancy.

### THE BOYS NON-RECORDING GAS CALORIMETER

In this apparatus, which is shown in section in Fig. 33, the gas is burned at two flat-flame burners B, which are situated in a chimney E forming the centre of the annular vessel D. The lower portion of D forms a trough in which the water condensed from the products of combustion collects and runs off by a side tube F; in this way the amount of water produced from the combustion of a given volume of gas may be measured, giving the data necessary for the calculation of the nett calorific value of the gas. The products of combustion pass up within the chimney and are deflected downwards by the water-cooled head H, passing over five turns of copper tubing M, on the outside of which is sweated a meshwork of copper wire to ensure mixing of the gases and to increase the surface available for transmitting heat. After passing over the lower turn of tubing, the gases are deflected upwards by an insulating baffle Q over four turns of similar copper tubing N, in series with M, finally passing out through a number of holes in the lid of the calorimeter. It is important that the bottom turns of the tubing should be submerged in the condensed water, as shown in the figure.

The water enters the calorimeter by the T-piece O, passing over the bulb of the inlet thermometer, down through the coil N, and up through M, after leaving which it traverses the passages in H, and the spiral passages formed by L, L, L, and escapes over the bulb of the outlet thermometer by the T-piece P, and thence into a change-over funnel either into the measuring cylinder or into the sink as required.

## Fuel Testing

### Method of Testing

The specification for testing the calorific value of coal-gas is laid down in detail in the General Notification of the Gas Referees, 1930 (H.M. Stationery Office), which should be consulted. The following abbreviated description is slightly modified but is consistent therewith :

The apparatus, connected as in Fig. 34, is tested for leaks by

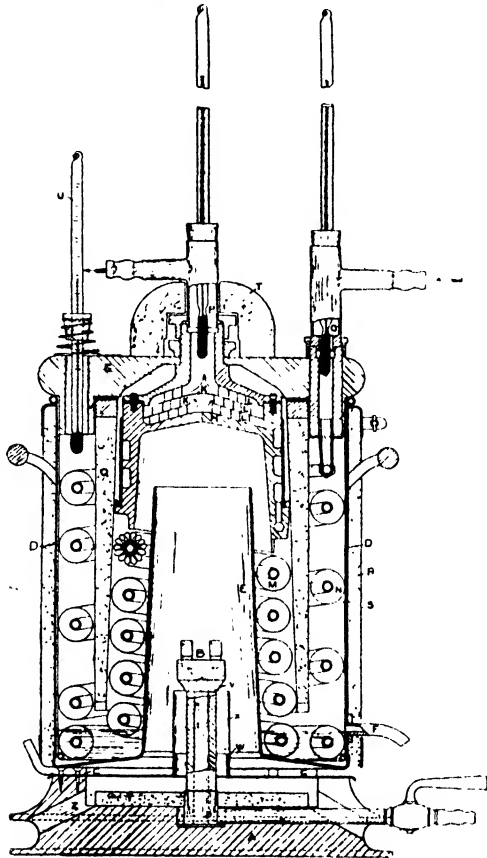

FIG. 33.—The Boys Calorimeter.  
(By courtesy of Griffin & Tallock, Ltd.)

slipping the ends of a piece of india-rubber tubing over the burners and turning the gas on full. Should the meter hand move forward a hundredth of a revolution in 4 minutes, the leak must be located and repaired.

The level of water in the meter is adjusted correctly and the gas is turned on and lighted. If either flame is out of shape, the burner must be cleaned or replaced. The rate of flow of gas is adjusted by one of the cocks on the inlet side of the meter (the regulating tap on

# The Boys Non-Recording Gas Calorimeter

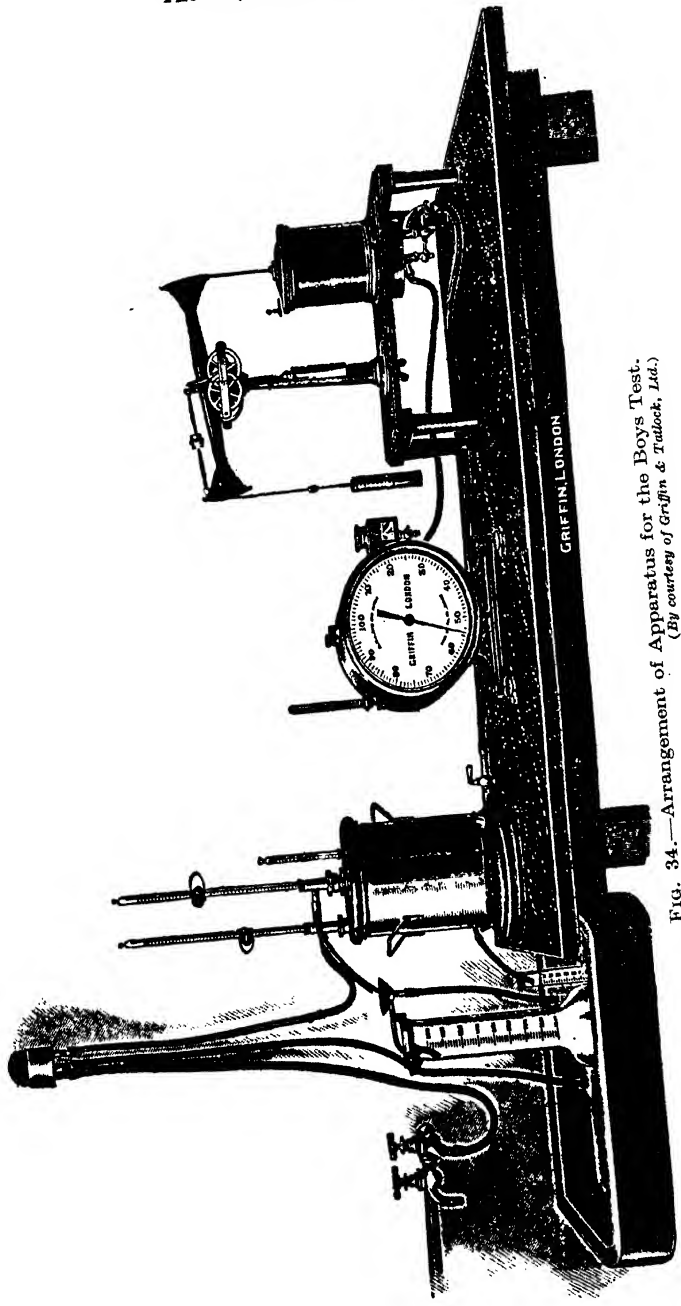

FIG. 34.—Arrangement of Apparatus for the Boys Test.  
(By courtesy of Griffin & Tubbok, Ltd.)

## Fuel Testing

the calorimeter must always be kept fully open while testing) so that the heat produced by the combustion of the gas is approximately 39 B.Th.Us. per minute.

The water is turned on so that when there is a regular flow through the calorimeter, a little passes over the overflow of the constant-level device and the rate of flow should be adjusted so that the rise in temperature of the water in passing through the calorimeter is as nearly as possible 20° C.

Water is poured into one of the holes in the lid of the calorimeter until it begins to run out of the outlet F. Care must be taken that the vent on F is not choked.

The calorimeter is placed on its base and the time is noted and entered on the report as the "time of starting the calorimeter." The measuring vessel, after being drained for 2 minutes, is placed in position and the change-over funnel is arranged so that the outlet water runs into the sink. The hot-water outlet from the calorimeter should be above the change-over funnel, and should not touch it.

After conditions have been allowed to stabilise themselves for not less than 45 minutes, observations may be started. When the meter hand is at 75, the inlet temperature of the water is read; at the moment when it reaches 100, the funnel is moved so as to direct the water into the measuring vessel; the time is noted and entered as the "time of testing." When the meter hand reaches 25, the first reading of the outlet temperature is made, and so on at every quarter revolution till fifteen readings have been taken. The meter hand will then be at 75. Readings of the thermometers are estimated to the nearest one-hundredth of a degree.

At every turn of the meter hand except the last, a reading of the inlet thermometer is made when the meter hand is between 75 and 100. At the moment when the meter hand reaches 100 after the last outlet temperature has been read, the change-over funnel is moved so as to run the outlet water into the sink. The barometer and the thermometers, showing the temperatures of the effluent gas, of the air in the room and of the gas meter, are then read to the nearest degree Fahrenheit. The manometer showing the pressure at which the gas is supplied to the meter is also read.

The water in the measuring vessel is stirred, the amount is read to the nearest fifth of a division and the temperature is taken to the nearest tenth of a degree Centigrade. At 15° C. the reading gives the weight in grams; for higher temperatures, a correction for the apparent expansion of water in glass must be made as in Table XXI.

The numbers of the inlet and outlet thermometers are noted, and any corrections shown on the calibration certificates are made to the readings. The mean rise in temperature is calculated and

## The Boys Non-Recording Gas Calorimeter

### TABLE XXI

CORRECTION FOR THE APPARENT EXPANSION  
OF WATER IN GLASS

Temperature °C.	Subtract Thousandths from Volume Reading.
Below 18·5 . . .	0
18·5 to 23·5 . . .	1
23·6 to 28 . . .	2
28·1 to 31·5 . . .	3
31·6 to 34·5 . . .	4
34·6 to 37·5 . . .	5
37·6 to 40·5 . . .	6

multiplied by 11·976, and by the gas volume factor,\* the product giving the uncorrected calorific value of the gas. A correction equal to two-fifths of the difference between the temperatures in degrees Fahrenheit of the effluent gases and the surrounding air is added to or subtracted from (according as the effluent gases are at a temperature above or below the air) the uncorrected calorific value of the gas. The result is the number of British Thermal Units (gross) produced by the combustion of 1 cu. ft. of the gas at 60° F. under a pressure of 30 in. of mercury and saturated with water vapour.

The amount of condensed water resulting from the combustion of the gas is also measured. The condensed water is led into a flask not less than 15 minutes after the calorimeter has been placed in position, and the amount collected in not less than 20 minutes is determined and entered in the report. If the water collected shows a rate of over 175 ml. per hour, the unions and coils of the calorimeter should be examined for leaks, and if any are found, the test must be discarded.

### Notes on the Method of Calculation

The heat from the combustion of  $\frac{1}{2}$  cu. ft. of gas is the weight of water collected in kilos  $\times$  the rise in temperature in kilogram calories. To convert this to B.Th.Us., the factor is 3·97, but as already explained (p. 183), a factor of 3·992 is used, hence the heat

\* A table giving the gas volume factors is given in the Notification. When using the table, the "barometer inches of mercury" should include the pressure at which the gas is supplied to the meter, and should therefore be the height of the barometer as read, *plus* the equivalent inches of mercury read on the manometer between the governor and the meter.

### Fuel Testing

per  $\frac{1}{3}$  cu. ft. of gas is kilos water collected  $\times$  rise in temperature  $\times$  3.992, and the heat per cu. ft. of gas is this multiplied by 3. Now  $3 \times 3.992 = 11.976$ , which is the factor mentioned above.

The gas volume factors given in the Notification are the reciprocals of those calculated to reduce the volume, as measured, to standard conditions, this arrangement being adopted so that the calculation may be simplified by requiring the addition of four logarithms (or a series of multiplications), whereas were the ordinary correction factor employed (called the "Tabular Number" by the Gas Referees), it would be necessary to subtract its logarithm from the sum of the other three.

#### FORM WITH EXAMPLE OF CALCULATION

Date, 21/10/34		Time of starting calorimeter, 10.15 a.m.	
Water		Time of testing, 11.0 a.m.	
Inlet ° C.	Outlet ° C.	Time of revolution of meter hand, 1 min.	
15.30	35.50	2 secs.	
	0.49	Water collected 2065 ml.	
	0.49	Correction — 6	
	0.48	Corrected vol. 2059 ml. (2.059 kilos).	
0.32	0.50	Barometer 29.83 in.	
	0.51	Manometer 1 in. water (0.07 in. Hg).	
	0.52	Total pressure 29.90 in.	
	0.51	Meter thermometer 61° F.	
0.32	0.49	Gas volume factor 1.006.	
	0.49	Effluent gas 66° F.	
	0.51	Air 61° F.	
	0.49	Difference 5° F.	
	0.50	Correction to be added to calorimeter result $\frac{2}{5} \times 5$ or 2 B.Th.Us.	
15.32	35.50	Average.	
— 0.04	— 0.02	Thermometer corrections.	
	20.20	Rise in temperature.	
Log.	11.976	Condensed water 56 ml. in 30 minutes.	
"	20.20	112 ml. in 1 hour.	
"	2.059		
"	1.006		
"	2.6999		
Uncorrected calorimeter result		501.1 B.Th.Us. per cu. ft.	
Add correction . . . .		2.0	
Corrected calorific value .		503.1 " "	

## The Jones-Miller Small-Scale Gas Calorimeter

*Calculation of the Gas Volume Factor.*—This may be derived from first principles. The gas was measured in a wet meter under a total pressure of 29.90 in. of mercury. The pressure of the dry gas was therefore 29.90 — 0.54 in. or 29.36 in. The standard conditions are, however, 60° F. and 30 in. Hg., saturated, i.e. pressure of dry gas 30.00 — 0.52 or 29.48 in. Hence the correction factor (tabular number) will be  $\frac{459.4 + 60}{459.4 + 61} \times \frac{29.36}{29.48}$ , or 0.994, the reciprocal of which is 1.006.

### Calculation of the Nett Calorific Value

The British Standard Definition of nett calorific value is as follows: "The *net calorific value* of a fuel gas determined at constant pressure is the number of heat units liberated by the complete combustion in air of a unit volume of the gas saturated with water vapour, both air and gas being at 60° F., while the effluent gases are cooled to 60° F. and all water vapour contained in them is assumed to remain in the vapour state."

The hygrometric state of the air used for combustion is not specified.

In the example given, 1/12 cu. ft. of gas was burned in 62 seconds,

hence the time taken to burn 1 cu. ft. would be  $\frac{12 \times 62}{60} = 12.4$

minutes, and the water condensed per cu. ft. of gas  $\frac{56 \times 12.4}{30} = 23.2$

ml., or as nearly as may be, 23.2 gm. Latent heat of condensation of steam at 60° F., 586 gm. calories per gram. Therefore the de-

duction from the gross calorific value =  $\frac{23.2 \times 3.968 \times 586}{1000} = 53.8$

B.Th.Us. per cu. ft. The net calorific value is thus 503.1 — 53.8 = 449.3 B.Th.Us. per cu. ft. at S.T.P.

### THE JONES-MILLER SMALL-SCALE GAS CALORIMETER

This apparatus, which was designed by J. H. Jones and J. M. Miller at the Newcastle Survey Laboratory of the Fuel Research Board, is specially adapted to the determination, with reasonable accuracy, of the calorific values of small samples of gases such as those obtained in carbonisation assays of coal. A full description of the calorimeter, from which the following account is condensed, is given in "Fuel." <sup>2</sup>

The apparatus consists of four parts: (i) a burette in which the gas is measured; (ii) arrangements for the supply of oxygen;



## Fuel Testing

(iii) the burner ; and (iv) the calorimeter proper in which the gas is burned and the heat is measured by the rise in temperature of a known weight of water as in the bomb calorimeter.

(i) *The Gas Burette* (Fig. 35).—This consists of a water-jacketed glass tube approximately 4 cm. in diameter and 35 cm. long, fitted with a two-way tap which is used to fill the burette and to deliver the gas to the burner. The volume from the calibration mark at the tap to the constriction *b* is about 350 ml. and is the volume of gas burned for each determination ; this volume must be determined accurately for each apparatus. The volume contained in the

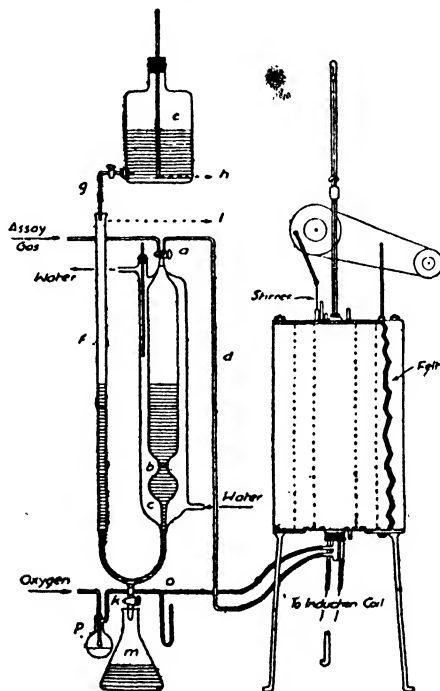

FIG. 35.—The Jones-Miller Gas Calorimeter.

lower bulb *c* is about 30 ml. and is used to sweep out the capillary tube *d* and the burner before commencing a determination. The aspirator bottle *e* contains a 20 per cent. solution of magnesium chloride which can be delivered at a constant rate (about 100 ml. per minute) into the side tube *f*.

It is important that the water jacket should be adequate and that the temperature should remain constant during a determination. Before being measured, the gas is allowed to remain in the burette for at least 5 minutes, after which it is assumed that the temperature is that of the water jacket. The thermometer should be accurate, and the temperature should be read to the nearest 0.1° C., which is

### The Jones-Miller Small-Scale Gas Calorimeter

equivalent to 0.2 B.Th.U. in the reported calorific value for a gas of 550 B.Th.U.s. per cu. ft.

For practical purposes, it is unnecessary to make any correction for the error due to solution of the constituents of high calorific value of the gas in the magnesium chloride, since the solubility is low, while in addition, this error is largely compensated for by the assumption that the gas is saturated with water vapour, which in fact it is not, on account of the reduction in the vapour pressure caused by the dissolved magnesium chloride.

(ii) *The Supply of Oxygen.*—Oxygen is obtained from a cylinder, a suitable pressure, corresponding to the desired rate of flow, being controlled by reference to a manometer placed before the capillary *o*. The rate of flow of oxygen is not critical, and after the supply

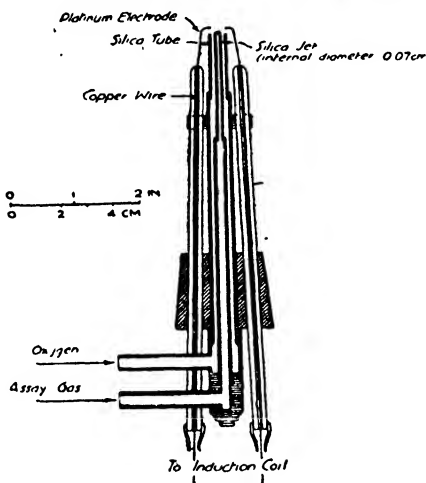

FIG. 36.—Burner of the Jones-Miller Gas Calorimeter.

of oxygen has been regulated at the start of a determination, no further adjustment should be required.

With the burner specified, from 50 to 100 per cent. excess oxygen gives satisfactory results, and experiments have shown that no significant differences in the results are observed if the oxygen/gas ratio is varied fairly widely. An undue excess of oxygen should, however, be avoided, otherwise the volume of waste gases is increased, which tends to aggravate the loss of heat from the calorimeter.

Since, if dry oxygen is passed into a moist combustion chamber, under normal conditions, the temperature falls at about  $0.004^{\circ}$  C. per minute, the oxygen is bubbled through water in *p* before entering the calibrated capillary tube.

(iii) *The Burner.*—This is illustrated in Fig. 36; it is constructed of brass with an internal silica jet and an external silica tube, ground

## Fuel Testing

and cemented into position. The metal parts are screwed and are readily detachable for cleaning. The oxygen is supplied through the annular space between the tubes while the gas passes through the inner tube, burning quietly as a small flame in an atmosphere of oxygen. The diameter of the jet should be as nearly as possible 0.07 cm. for a rate of flow of gas of 100 ml. per minute, and should be fixed in the burner so that the tip is about 1 mm. above the outside tube to allow for the slight volatilisation of the silica which becomes apparent after prolonged use.

The burner is held in a rubber bung which fits the combustion chamber; the bung also carries two insulated platinum electrodes

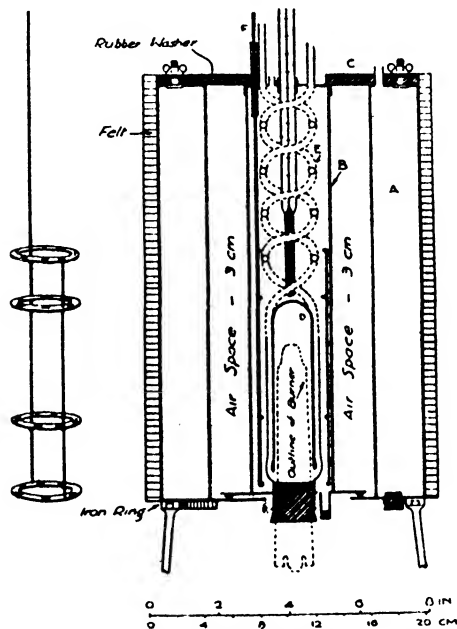

FIG. 37.—The Jones-Miller Gas Calorimeter. The Calorimeter.

which are used to ignite the gas, a small induction coil being used to provide the spark. The burner is adjusted so that it is central in the combustion chamber, with a distance of approximately 3 cm. between the top of the silica tube and the top of the chamber, to prevent the flame from impinging on the copper.

To ensure that ignition takes place at the beginning of a determination, sparking is allowed to continue for 10 seconds. A small correction for the heat due to the spark must be made and should be determined for each instrument.

(iv) *The Calorimeter* (Fig. 37).—This consists of an annular copper vessel A, holding from 7 to 8 litres of water, which surrounds the calorimeter proper and from which it is separated by an

## The Jones-Miller Small-Scale Gas Calorimeter

air-space of 3 cm. The outer vessel is lagged with felt on the outside and enamelled white on the inside: it is provided with a hole at the top for filling and a stoppered outlet at the bottom for draining.

The calorimeter B is also of copper and consists of a cylinder 6 cm. in diameter and 30 cm. long, with a combustion chamber and drainage pipe at the base. It is supported by three non-conducting wedges which make line-contact with the base of the jacket, and is held in position by the cover C. This is of brass, with a rubber washer on the under side to minimise transfer of heat. The products of combustion pass down the chamber and leave through the thin-walled spiral brass tubes E. The stirrer F is shown in perspective and is constructed to provide thorough mixing of the water in all parts of the calorimeter. The lid carries the fittings necessary to locate the thermometer, stirrer and exit tubes.

The thermometer should be of the type used with the bomb calorimeter: it should be graduated to  $0.01^{\circ}\text{C}$ . and provided with a N.P.L. certificate giving corrections to  $0.002^{\circ}\text{C}$ . Readings are carried out with a small microscope.

Determinations are facilitated if the stirrer is operated mechanically and if a small "buzzer" vibrator is fitted to the thermometer to minimise sticking of the mercury thread.

### Method of Operation

Water should flow through the jacket of the burette for about half an hour before a test is commenced so that conditions may be stabilised. The outer jacket of the calorimeter should contain water at the temperature of the room. The calorimeter, which has been previously filled and allowed to drain, is charged with a weighed amount of water (about 750 gm.) at a temperature of approximately  $1^{\circ}\text{C}$ . lower than that of the outer jacket, the rise with a gas of calorific value 550 B.Th.U.s. per cu. ft. being approximately  $2^{\circ}\text{C}$ . The burner is inserted and the burette is filled with gas, after purging the inlet tube.

The procedure is similar to that with a bomb calorimeter, and is divided into three periods.

*Preliminary Period.*—The water in the calorimeter, is stirred continuously and when the rate of change of temperature is steady, readings are taken to the nearest  $0.001^{\circ}\text{C}$ . at intervals of a minute. Before the first reading is taken, the stream of oxygen is started and adjusted to the predetermined rate. By this time the gas in the burette should have attained the temperature of the water jacket and after the first minute reading taps *a* and *g* (Fig. 35) are opened, allowing magnesium chloride to flow into the side tube and

## Fuel Testing

gas of the volume  $c$  to sweep out the tubes and the burner. When the bulb  $c$  is almost full of liquid, tap  $g$  is nearly closed, so that when the calibration mark at the constriction is reached the liquid in the side tube is at the same level, i.e. the gas is at atmospheric pressure. Taps  $a$  and  $g$  are then closed and the temperature of the water in the jacket of the burette is recorded as the temperature of the gas. The oxygen is allowed to flow for 3 minutes after closing tap  $a$  to remove any gas from the combustion chamber and to prevent the formation of an explosive mixture. At the beginning of the sixth minute, taps  $a$  and  $g$  are opened, in the order mentioned, and the gas is ignited by sparking. It is important that sparking should begin before the taps are opened, and that it should continue for 10 seconds.

*Chief Period.*—During the combustion of the gas, readings are taken to the nearest  $0.01^{\circ}$  C. When the magnesium chloride reaches the top calibration mark, taps  $a$  and  $g$  are closed. The temperature continues to rise slowly for a further 3 or 4 minutes, during which readings are taken to the nearest  $0.001^{\circ}$  C.

*After Period.*—Six subsequent readings are taken to the nearest  $0.001^{\circ}$  C. at intervals of 1 minute to give the rate of cooling. The Regnault-Pfaundler radiation correction is applied to enable the true rise in temperature to be calculated.

## Water Equivalent of the Apparatus

As with the bomb calorimeter, the water equivalent should be calculated from the weight of the components and checked by burning a known volume of gas of known calorific value in the apparatus, the water equivalent being calculated from the relation

$$\frac{\text{heat evolved}}{\text{rise in temperature}}$$

## Precision of the Method

It has been shown by experiment that the mean difference to be expected between duplicate determinations on gases from carbonisation assays is about 2.5 B.Th.Us., which corresponds to a probable error of 1.5 units on gases of from 550 to 600 B.Th.Us. per cu. ft., that is approximately 0.3 per cent. Furthermore, the agreement with the Boys calorimeter has been investigated, with the result that over a range of calorific values from 312 to 1250 B.Th.Us. per cu. ft. the agreement was found to be reasonable and adequate for all small-scale carbonisation experiments. The loss of heat due to sensible heat in the waste gases is so small that no correction is required.

### THE PARTIAL DRYING OF GAS

It is now a common practice partially to dehydrate town-gas before distribution in order to reduce the difficulties which arise from deposition of water in mains, service pipes and meters. Although partial drying does not alter the calorific value as defined on page 180, the removal of a certain proportion of water vapour from the gas does result in a higher calorific value of the gas as received by the consumer, provided that his gas is measured in a dry meter. The Gas Undertakings Act of 1929 therefore modified the definition of calorific value in the following words: "The calorific value of gas means, for the purposes of this Act, the number of B.Th.U.s. (gross) produced by the combustion of 1 cu. ft. of the gas measured at 60° F., under a pressure of 30 in. of mercury, and (*except as otherwise prescribed by the Gas Referees*) saturated with water vapour." Precision is given to the intention of Parliament by a clause in the Gas Light and Coke Co.'s Act of 1929 referring to the testing of dehydrated gas. This clause says: "The calorific value of gas means, for the purpose of this Act, the number of B.Th.U.s. (gross) produced by the combustion of 1 cu. ft. of the gas measured at 60° F., under a pressure of 30 in. of mercury, *and containing such proportion (if any) of water vapour as is contained in the gas supplied to consumers.*"

Whenever, therefore, partially dried gas is being tested, a correction must be made to allow for the fact that the gas as supplied was not saturated at 60° F., and it is thus necessary to determine the quantity of water vapour actually associated with the dry gas, either directly or by determining the dew-point.

### Direct Determination

The gas is passed slowly through two weighed U-tubes containing calcium chloride, then through a third similar weighed tube which acts as a guard tube to prevent back diffusion of water vapour from a bubbler containing water whose function is to saturate the gas before it is measured in a wet meter. The temperature of the meter, the height of the barometer and the supply-pressure of the gas to the meter are noted, and when a sufficient volume of gas has been passed, the flow is stopped, the U-tubes are removed to the balance-room and weighed after standing for half an hour. The method of calculation may best be shown by an example: Volume of gas as metered, 1.00 cu. ft. Temperature, 61° F. Weight of water collected, 0.1760 gm. Total pressure, 30.2 in. Hg. Volume of gas, reduced to S.T.P. =  $1.000 \times \frac{519.4}{520.4} \times \frac{29.64}{29.48} = 1.0035$  cu. ft.

## Fuel Testing

Water collected,  $\frac{0.176}{453.6 \times 18} = 0.00002155$  lb.-mol., or per lb.-mol. of gas at S.T.P. =  $\frac{0.00002155 \times 385}{1.0035} = 0.00827$ , i.e. percentage by volume = 0.83, which, from hygrometric tables, corresponds with a dew-point of 40° F. The percentage of water vapour by volume for a saturation temperature of 60° F. = 1.74. Hence, the percentage correction to be applied to the calorific value at S.T.P. to

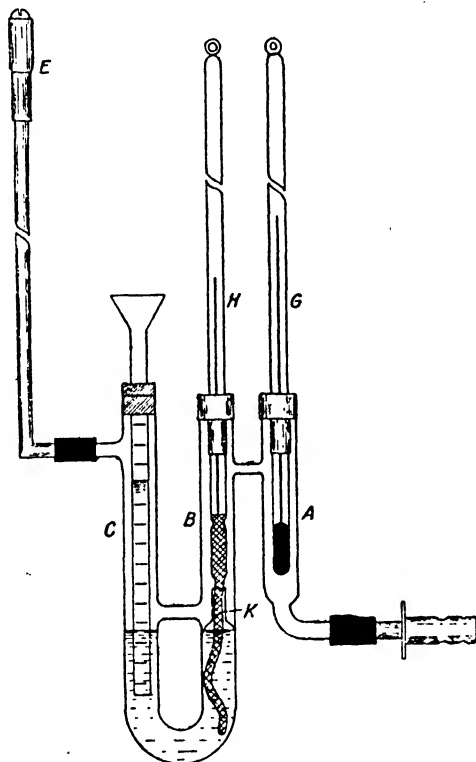

FIG. 38.—The Eaton Wet and Dry Bulb Hygrometer.

reduce it to the calorific value of the gas as delivered, namely, at 60° F. and 30 in. Hg., saturated with water vapour at 40° F.

$$= 100 \left\{ \frac{1.74 - 0.83}{100 - 1.74} \right\} = 0.93.$$

## Indirect Determination

This involves the determination of the dew-point of the gas, usually by a modified wet and dry bulb hygrometer. A suitable instrument is that devised by F. J. Eaton of the Gas Light and Coke

## The Partial Drying of Gas

Co., and illustrated in Fig. 38. The apparatus consists of three similar tubes, A, B and C. Tubes A and B contain the dry and wet bulb thermometers, G and G', while tube C, which is fitted with a graduated internal tube, supplies water to the wet bulb and also enables the pressure of the gas to be measured. The rate of flow of gas over the thermometers is controlled by a standard orifice E, fitted just below the burner at which the gas issuing from the apparatus is disposed of. An inner tube K is sealed into B with the object of preventing contamination of the gas with the water supplied to the wet bulb. The annular space between the thermometers and the tubes is made as small as possible to enable a high velocity to be obtained with a small volume of gas.

To determine the dew-point, the gas is passed through the apparatus at the appropriate rate, and when equilibrium is established, readings are taken of the dry and wet bulb temperatures. The dew-point may then be calculated from

$$p = p' - KB(t - t')\{1 + 0.000636(t' - 32)\}, \text{ where,}$$

$p$  = vapour pressure at the dew-point,

$p'$  = " " " " temperature of the wet bulb,

$K$  = a constant depending upon the apparatus and the gas being tested,

$B$  = barometer reading,

$t$  = dry bulb temperature, and

$t'$  = wet bulb temperature.

The constant  $K$  is determined by passing gas over sufficient calcium chloride to dry it thoroughly, and thence through the apparatus at the required rate. By substituting in the formula, and assuming  $p$  to be zero,  $K$  may be calculated.  $K$  is found to depend primarily on the rate of flow of gas, which must therefore be standardised, and also to some extent on the composition of the gas being tested.  $K$  must thus be determined for each instrument and for each type of gas to be tested.

Having determined the dew-point, the calculation of the percentage correction to be made to the calorific value may be carried out as already indicated.

### BIBLIOGRAPHY

<sup>1</sup> C. G. Hyde and F. E. Mills, "Gas Calorimetry," 1932.

<sup>2</sup> J. H. Jones and J. M. Miller, *Fuel in Science and Practice*, 1937, **16**, pp. 177-83.



## CHAPTER XII

### TESTS ON LIQUID FUELS

LIQUID fuels comprise a wide variety of products, ranging from highly volatile aviation and motor spirits to heavy residual fuel oils. The examination of liquid fuels and the interpretation of the results of tests is a task for the specialist, and one which can only successfully be undertaken by the experienced petroleum technologist. The fuel chemist, however, from time to time is called upon to examine fuel oils and allied materials with a view to ascertaining whether they comply with certain specifications, and some knowledge of the methods is therefore necessary.

The majority of tests on petroleum products are not intended to give absolute figures, but are designed to enable practical tests to be applied so that the materials may be evaluated and compared; the apparatus and methods of testing must therefore be carefully standardised and the specifications must be rigidly adhered to, otherwise consistent and misleading results will be obtained.

Standardisation has been effected by the work of the Chemical Standardisation Committee of the Institute of Petroleum, and the results are laid down in "Standard Methods for Testing Petroleum and Its Products," 1935, obtainable from the Institute. In this chapter, tests which are applicable particularly to fuel, diesel and gas oils are described and certain of the apparatus is illustrated, by permission of the Institute of Petroleum, to whom the Author desires to express his thanks.

#### SAMPLING

Correct sampling is no less important in dealing with liquid than with solid or gaseous fuels; the analyst can only report on the sample which has been submitted to him, and however accurate and painstaking he may be, the value of his results is entirely dependent on how far the sample is representative of the bulk of the material from which it was taken. Where samples are to be taken to ascertain whether a consignment of fuel is in accordance with a specification, the method of sampling should be agreed upon by the contracting parties.

Fourteen different types of sample are listed in "Standard Methods," and the following is a résumé of them in so far as they are applicable to liquid fuels:

## Sampling

*Average Sample.*—An average sample is one so taken as to contain portions from all positions in the container, or from a pipe, in the proportion in which the material being sampled exists.

In ordinary circumstances it is practically impossible to obtain an average sample of a liquid except, perhaps, through a continuous sampling connection from a vertical run in a pipe with specially constructed draw-off pipes, or by vigorously agitating and stirring the contents of a vessel and drawing off a sample while the contents are still agitated. Since neither condition is likely to be met in ordinary practice, no further consideration need be given to this type of sample.

*All-Levels Sample.*—This is obtained by submerging a closed sampling vessel to a point as near as possible to the draw-off level, opening it and raising it at such a rate that it will be nearly but not quite full when withdrawn. Although the method is widely used for ship tanks, barges and large storage tanks, the sample can never be truly representative, since (a) the depth may not be proportional to the volume of the tank, (b) the sample container cannot be moved with a uniform speed, and (c) the rate of filling the container is proportional to the square root of the depth of immersion below the surface of the opening of the sampling vessel.

*Upper Sample.*—An upper sample is one taken at a point 10 per cent. of the depth of a vessel of uniform cross-section, or 10 per cent. of the diameter of a horizontal cylindrical tank below the surface.

*Middle Sample.*—A middle sample is one taken at half the depth of the material.

*Lower Sample.*—A lower sample is one taken at a point 10 per cent. of the depth of a vessel of uniform cross-section, or 10 per cent. of the diameter of a horizontal cylindrical tank above the bottom of the vessel.

Where a substantial layer of water or emulsion exists at the bottom of the container, samples may have to be taken at other suitable levels.

*Composite Sample.*—A composite sample is a mixture of upper, middle and lower samples containing, for vessels of different shapes, proportions by volume which correspond approximately to the volumes of the material at these levels as in Table on page 204.

Where horizontal cylindrical tanks are only partly full, the sampling levels and the quantities must be modified. For details, readers are referred to "Standard Methods."

*Continuous or Bleeder Sample.*—A continuous sample is one obtained from a pipe or conduit conveying the material, in such a manner as to give at all times a representative average of all the sections and section velocities of the stream throughout the period of transit.

## Fuel Testing

TABLE XXII  
SAMPLING LIQUID FUELS

	Proportions in Composite Samples.	
	Vessels of Uniform Cross Section in Horizontal Plane.	Horizontal Cylindrical Tanks, if Full.
Upper sample . parts	1	1
Middle „ . „	3	8
Lower „ . „	1	1

*Intermittent or Dipper Sample.*—This is taken by interposing a collecting vessel into the path of a free-flowing stream so as to collect a definite volume from the full cross-section of the stream at regular intervals of time, or at intervals of time so varied as to obtain samples in proportion to the amounts being delivered.

*Mixed Sample.*—Obtained by mixing or vigorously stirring the contents of the original container and pouring or drawing off the desired quantity.

*Thief Sample.*—Is taken by means of a sampling tube from a specified point in the containing vessel which is being sampled.

*Drain Sample.*—A drain sample is taken by opening the draw-off or the discharge-valve and drawing off a suitable portion of the material.

*Bottom Sample.*—A bottom sample is obtained by collecting a portion of the material lying on the bottom surface of the tank, container or pipe-line at its lowest point.

Drain and bottom samples are usually taken only to examine for moisture, sludge or scale, or to draw off any free water or extraneous material.

### Bottle Sampling

This method is applicable to (a) tank cars (road or rail), (b) shore tanks, and (c) ship or barge tanks, which are the types of containers most likely to be met with in dealing with liquid fuels.

Clean weighted glass or metal bottles may be used, the size of opening of which does not exceed  $1\frac{1}{2}$  in. diameter. They should be supplied with clean corks and a string for lowering into the tank, so arranged that by means of the string the cork may be withdrawn when the bottle has been lowered to desired depth. Alternatively, a metal dip-can may be used, provided with means whereby a

## Flash-Point

implying a guarantee that the instrument complies with the specification:

The essential parts of a flash-point apparatus are an oil cup, 2 in. diameter and 2.2 in. deep internally, a cover, provided with ports for the introduction of a test-flame and for observation, a heating bath or jacket and a burner for heating it.

### The Abel Flash-Point Apparatus ✓

This is illustrated in Figs. 42 and 43. *The oil cup A* has within it a gauge B consisting of a piece of wire bent upwards and ter-

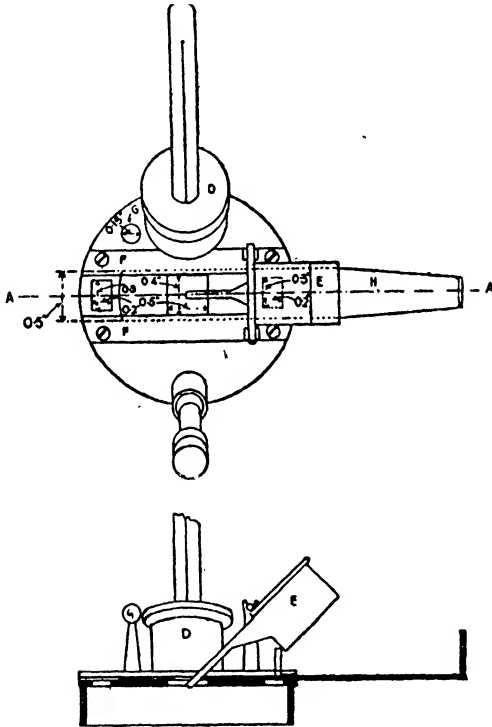

FIG. 43.—Cover, Abel Flash-Point Apparatus.

minating in a point which indicates the limit to which the cup must be filled with oil.

*The close-fitting cover* carries a thermometer socket D, a test lamp E, supported in trunnions, a pair of guides F in which a slide H moves and a white bead G. The cover is pierced with three rectangular holes symmetrically placed on a diameter, one central and the others as close as practicable to the inner sides of the rim of the cover; these holes are covered or uncovered by the slide H in which are two holes, one corresponding to the central hole in the

## Fuel Testing

cover and the other to one of the holes at the side. The movement of the slide is restricted by stops, and its length and the disposition of the holes are such that at the outer extremity of the movement of the slide, the holes in the cover are simultaneously just completely opened, while at the inner extremity of the slide they are completely closed.

The trunnions supporting the test lamp are fixed to the top of the guides and the lamp is mounted in the trunnions so that it is free to oscillate. The lamp is provided with a jet to contain a wick, and is arranged so that when the slide is moved so as to uncover the holes, the oscillating lamp is caught by a pin and tilted over the central hole so that the test flame occupies a central position within the hole. A suitably mounted gas-jet may be substituted for the lamp.

A white bead, whose dimensions represent the size of the test flame to be used, is mounted in a visible position on the cover.

Provision may be made in the cover for the reception of a stirrer (as shown in the figures); this is for use only with viscous materials. When the stirrer is not required, the bush through which it is inserted is filled by a flat-headed cylindrical plug.

*The heating-bath* consists of two co-axial, flat-bottomed cylindrical vessels, the space *K* between them being used as a water jacket. The jacket is provided with a funnel and overflow pipe and with a thermometer-socket *M*. The bath rests on a cast-iron tripod stand, to the ring of which is attached a cylindrical copper jacket *N* in which the bath is supported.

The bath is heated by a spirit lamp, but any other means approved by the Board of Trade may be substituted for it.

*Method for Oils Flashing Below 90° F.*—The apparatus is set up in a position where it is not exposed to currents of air or a draught.

The water-bath is filled by pouring water into the funnel until it begins to flow out at the spout of the vessel; the temperature of the water at the beginning of a test must be 130° F., and no heat is applied to the water-bath during the test. After a test has been completed and before beginning another, the temperature of the water-bath is again raised to 130° F.; this is conveniently done while the oil cup is being emptied, cooled and refilled.

If an oil test lamp is used, it is prepared by fitting it with a piece of flat-plaited candle-wick and filling it with colza or rape oil up to the lower edge of the opening of the spout. The lamp must be trimmed so that when lighted it gives a flame of about 0.15 in. diameter, which is the size of the projecting white bead on the cover of the oil cup. If a gas test flame is employed, its size must also be adjusted to the size of the bead.

The bath having been raised to the proper temperature, the oil

## Flash-Point

to be tested is introduced into the cup, being poured in slowly until the level of the liquid just reaches the point of the gauge which is fixed in the cup. Before a test is begun, the temperature of the oil is brought approximately to 60° F. The cover, with the slide closed, is then put on to the cup and pressed down so that its edge rests on the rim of the cup, and the cup is then placed in the bath, care being taken to avoid wetting the sides of the cup with oil. The thermometer in the lid of the cup has been adjusted so as to have its bulb just immersed in the liquid, and its position must not under any circumstances be altered. When the cup has been placed in the proper position, the scale of the thermometer faces the operator.

The test lamp is then placed in position on the lid of the cup. When the temperature has reached 66° F. testing is begun, the test flame being applied once for every rise of one degree, as follows :

The slide is slowly drawn open while a metronome, set at 75 to 80 beats per minute, beats three times and is closed during the fourth beat. A pendulum of an effective length of 24 in. may be used instead of the metronome, counting one beat from one extremity of the swing to the other.

The height of the barometer is observed and recorded, but no corrections are made except in case of dispute.

*Method for Oils Flashing between 90° and 120° F.*—The air-chamber which surrounds the cup is filled with cold water to a depth of 1.5 in., and the heating vessel or water-bath filled as usual, but also with cold water. The lamp is then placed under the apparatus and kept there during the entire operation, and the temperature of the oil raised at the rate of 2° to 2½° per minute, the testing being carried out as laid down in the previous section, except that the test flame is first applied when the temperature has reached 80° F.

## The Pensky-Martens Flash-Point Apparatus

This instrument, which is used for all petroleum products having a flash-point above 120° F., is shown in section in Fig. 44, and consists of an oil cup A with a filling mark scribed round the interior, and provided with a lid, carrying a thermometer holder. There are three ports cut in the lid, one for admitting the test flame, and one on each side of it, for observing the flash. Over the lid, and operated by the spring handle G, is a revolving shutter H in which are three holes of the same dimensions as the ports in the lid. The shutter works between stops in such a way that when in one extreme position, the ports are completely open, while when it is at the other extreme, the ports are completely shut. When G is operated so as to open the ports, the test flame is automatically depressed into the testing position.

Passing through the lid into the oil cup is a stirrer C consisting

## Fuel Testing

of two small two-bladed propellers mounted on a steel shaft. The oil cup is seated in an air-bath B covered by a curved top plate of brass, and below the heating bath is an iron ring covered with wire gauze.

Two thermometers are provided, their ranges being from 20° to 230° F. and from 200° to 700° F. respectively.

*Method of Test.*—The oil cup is cleaned and dried, care being taken that no traces of any low-flash solvent used in cleaning remain in the cup, and the oil is then poured in up to the level indicated by

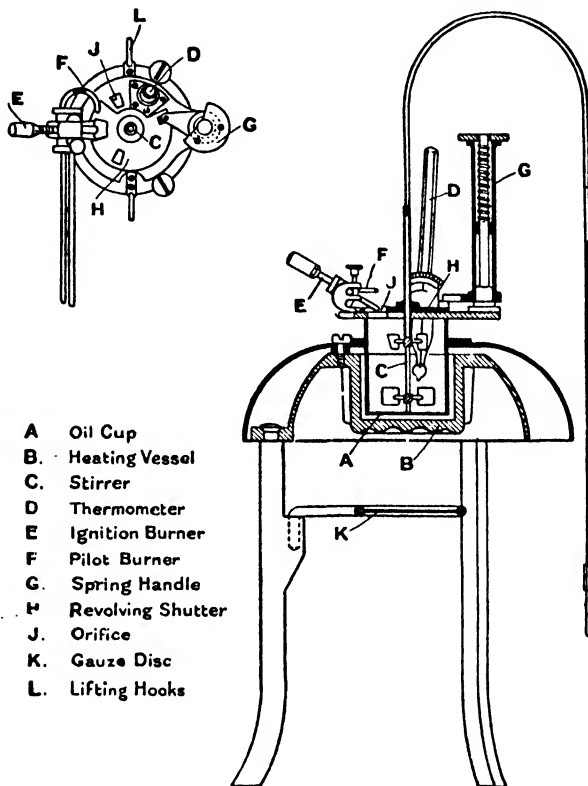

FIG. 44.—The Pensky-Martens Closed Tester.

the filling mark. The lid is placed in position, the thermometer is inserted in the holder, and the cup is set in the air-bath. The test flame is adjusted to the size of a bead 4 mm. in diameter. The apparatus is heated at the rate of from 9° to 11° F. per minute, and the stirrer is rotated at from 1 to 2 revolutions per second. Starting at a temperature of at least 30° F. below the flash-point the test flame is applied at temperature intervals of 2° F. (up to 220° F., or at intervals of 5° F. above 220° F.), in such a manner that the flame is lowered in one-half second, left in its lowered position for one

## Sediment Insoluble in Benzene

second, and quickly raised. While the test flame is being applied, stirring is stopped.

When the flash-point is nearly reached, a blue halo is often observed round the test flame, but this is not the actual flash. The temperature at which a distinct flash is visible in the two observation ports is recorded as the flash-point.

The barometric pressure is observed and recorded, but no correction is made except in case of dispute, in which case a correction of 1.6° F. is added to or subtracted from the observed temperature for each inch (25 mm.) at which the barometer stands below or above 29.92 in. (760 mm.).

Since the flash-point is the *minimum* temperature at which under the given conditions the oil gives sufficient vapour to ignite, a fresh sample of oil must be used for every test. With an oil which contains only a very small percentage of low-flash material, a second test on a single sample may well give a flash-point many degrees above the first, as in the first test all, or practically all, of the low-flash constituent will have evaporated.

### Drying the Sample

When gas oil or fuel oil are to be tested, the sample must first be dried. This is done as follows :

One hundred grams \* of well-dried calcium chloride are placed in a dry, wide-mouthed, stoppered bottle. 250 ml. of the oil are poured on the calcium chloride, the mouth of the bottle is closed by the stopper which is secured by string. The bottle is well shaken and is stood in a vessel containing water, which reaches to about one-third the height of the oil in the bottle. The water is heated to 50° C. (120° F.), and is maintained at this temperature for 7 hours, the bottle and its contents being well shaken at intervals of about an hour. The bottle and its contents are then allowed to cool, after which sufficient of the oil for test is filtered through paper in a Buchner funnel.

#### SEDIMENT INSOLUBLE IN BENZENE

This test may be used for crude mineral oils, fuel oils and lubricating oils. The sediment is the total amount of matter, other than water, which is obtained by centrifuging the oil with benzene, filtering and weighing the insoluble residue after it has been washed free from oil.

The sample must be thoroughly representative of the material to be tested, and the portion used must be representative of the

\* If less than 250 ml. of oil are available, correspondingly less calcium chloride is used.



## Fuel Testing

sample itself. Correct sampling for this test is by no means easy, but is absolutely essential.

*Apparatus.*—The centrifuge must be capable of whirling at the required speed at least two 100-ml. centrifuge tubes filled with water. It must be of sound design and rugged construction so that it may be operated without danger. The tube carriers must be so designed that the glass centrifuge tubes may be cushioned with water, rubber or other suitable material. The tube holders must be surrounded during the operation by a suitable metal shield or case, strong enough to eliminate danger if any breakage occurs.

The preferred form of centrifuge must have a diameter of swing (tip to tip of whirling tubes) of 15 to 17 in. and a speed of at least 1500 r.p.m. or the equivalent. If the available centrifuge has a diameter of swing varying from these limits, the proper speed is that which will give the same centrifugal force at the tips of the tubes as that obtained with the preferred form of centrifuge. The proper speed is calculated from  $\text{r.p.m.} = 1500\sqrt{\frac{16}{d}}$ , where  $d$  represents the diameter of the swing from tip to tip of the whirling tubes.

The centrifuge tubes must be made of stout glass and thoroughly annealed. Cylindrical tubes with round bottoms, approximately 140 mm. high and 50 mm. external diameter, of about 175 ml. capacity, are convenient.

*Method.*—Ten grams or other suitable quantity of the sample are accurately weighed into a centrifuge tube. Ten times the volume of crystallisable benzene is added and the whole is thoroughly mixed by stirring. The mixture is centrifuged for 30 minutes, or longer if necessary, to enable the sediment to collect. The tube is then removed from the centrifuge and the supernatant liquid is poured carefully through a dried and tared filter paper on a Buchner funnel. The sediment is washed several times with benzene by incantation, transferred to the paper and washed free from oil. The paper and sediment are then dried to constant weight.

### WATER IN LIQUID PETROLEUM PRODUCTS

Special care must be taken in sampling; not only must the sample be representative of the bulk of the oil to be examined, but the portion taken for the test must be truly representative of the sample itself.

The apparatus used is that of Dean and Stark (Figs. 45 and 46) and consists of:

(a) A distillation flask of glass or copper, round bottomed and of 500 ml. capacity.

## Water in Liquid Petroleum Products

- (b) A water-cooled reflux condenser, glass-tube type.
- (c) A special graduated receiver (Fig. 46), conforming to B.S.S. No. 756, 1939.
- (d) A gas burner or suitable electric heater.

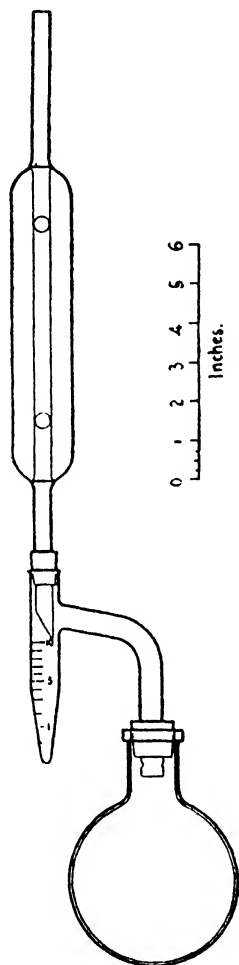

FIG. 45.—The Dean and Stark Apparatus for Determination of Moisture in Oil.

*(By courtesy of the Institute of Petroleum.)*

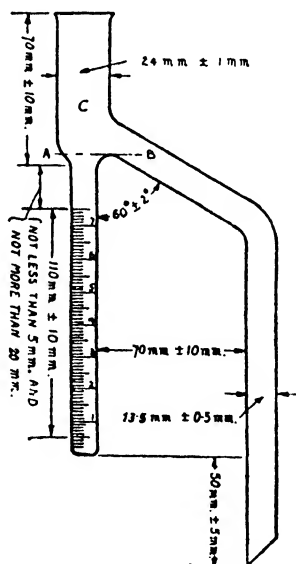

FIG. 46.—Receiver for the Dean and Stark Apparatus.

The general method consists in diluting the sample with gasoline, boiling under reflux and measuring the volume of water collected. The gasoline used must be free from water and when distilled by I.P. Method G3,\* it must give 5 per cent. of distillate at a

\* "Standard Methods," 1935.

## Fuel Test

temperature above 100° C. and not below 90° C., and 90 per cent. distillate at a temperature not exceeding 205° C.

*Method.*—Exactly 100 ml. of the oil to be tested are measured in an accurate 100-ml. graduated cylinder at room temperature and poured into the distillation flask. The oil remaining in the measure is transferred to the flask by rinsing with two successive portions of 50 ml. of gasoline, the cylinder being allowed to drain each time. The oil and gasoline are thoroughly mixed in the flask and a piece of porcelain (to prevent bumping) is added. The apparatus is assembled and the flask is heated so that condensed distillate falls from the end of the condenser at the rate of from two to four drops per second. Distillation is continued until no water is visible on any part of the apparatus except at the bottom of the receiver. This usually requires less than one hour; should a persistent ring of water appear in the condenser tube, it must be removed by suitable mechanical means, such as rubbing by a glass rod.

The volume of condensed water measured in the graduated receiver is recorded as “— per cent. Water, I.P. Method.”

### CARBON RESIDUE (CONRADSON METHOD)

The test is a means of determining the amount of residual carbon left when an oil is evaporated under specified conditions and is designed to measure the relative carbon-forming propensity of an oil. The results of the test must be considered in connection with other tests and the use for which the oil is intended. It furnishes information relative to lubricants for internal combustion engines, domestic oil fuels and oils used for the manufacture of gas.

*Apparatus* (Fig. 47).—A porcelain crucible A, wide form, glazed throughout, or a silica crucible; 29 to 31 ml. capacity, diameter of rim 46 to 49 mm.

B. A Skidmore iron crucible, flanged and ringed, 65 to 82 ml. capacity, 53 to 57 mm. inside, and 60 to 67 mm. outside diameter of flange, 37 to 39 mm. in height, supplied with a cover without delivery tubes and having the vertical opening closed. The horizontal opening of about 6.5 mm. must be kept clean. The outside diameter of the flat bottom must be from 30 to 32 mm.

C. A spun sheet-iron crucible with cover; 78 to 82 mm. outside diameter at the top, 58 to 60 mm. (approximately) high, and approximately 0.8 mm. thick. At the bottom of this crucible, a layer of about 25 ml. of dry sand, or enough to bring the Skidmore crucible, with cover on, nearly to the top of the sheet-iron crucible.

A triangle of nichrome wire of approximately 15 I.W.G., having an opening small enough to support the bottom of the sheet-iron crucible at the same level as the bottom of the asbestos block or hollow sheet-metal box E.

## Carbon Residue

D. A circular sheet-iron hood, from 120 to 130 mm. diameter, the height of the lower perpendicular side from 50 to 53 mm.; provided at the top with a chimney 50 to 60 mm. high and from 50 to 60 mm. external diameter, which is attached to the lower part having the perpendicular sides by a cone-shaped member, bringing the total height of the complete hood from 125 to 130 mm. As a guide for the height of the flame above the chimney, a bridge of approximately 3 mm. iron or nichrome wire is attached, having a height of 50 mm. above the top of the chimney.

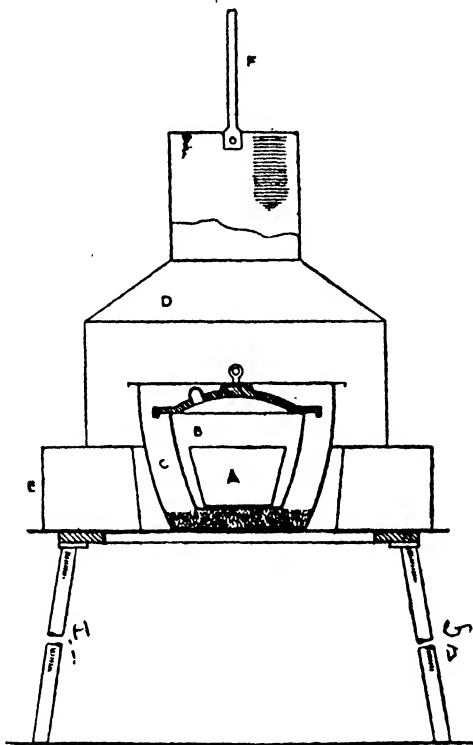

FIG. 47.—Carbon Residue Apparatus.

E. An asbestos block or hollow sheet-metal box, 150 to 175 mm. diameter if round, or on a side if square, 32 to 38 mm. thick, provided with an opening through the centre in the shape of an inverted cone 83 mm. in diameter at the bottom and 89 mm. at the top; this opening must be lined with sheet metal.

A Méker burner, 24 mm. diameter by 155 mm. high.

*Method.*—Two glass beads, about 0.1 in. diameter, are placed in and weighed with the porcelain or silica crucible A, into which 10 gm. of gas oil or light lubricating oil, free from moisture or suspended matter, are weighed accurately. When heavy lubricating oil or

## Fuel Testing

fuel oil is being tested, the amount of sample must be such that the residue of coke shall not exceed 0.4 gm. A result must never be accepted when the outside of the crucible shows evidence that frothing over has occurred. The weight of the sample must never exceed 10 gm.

The porcelain crucible is placed in the centre of the Skidmore crucible, the sand in the large sheet-iron crucible is levelled, and the Skidmore crucible is set exactly central in it. Covers are applied to both the Skidmore and the iron crucible, the cover of the latter fitting loosely to allow the vapours to escape freely.

The bare nichrome wire triangle is placed on a suitable stand or ring and on it the asbestos block or hollow sheet-metal box. Next, the sheet-iron crucible is centred in the block with its bottom resting on the triangle, and the whole is covered with the sheet-iron hood to distribute the heat uniformly.

Heat is applied with a high, strong flame from the burner, so that the pre-ignition period will be 10 min.  $\pm$  1½ min. (a shorter time may start the distillation so rapidly as to cause foaming or too high a flame above the chimney). When smoke appears above the chimney, the burner is immediately moved or tilted so that the flame plays on the sides of the crucible to ignite the vapours. The source of heat is then removed temporarily, and before it is replaced, the gas flame is adjusted so that the ignited vapours burn uniformly with the flame above the chimney but not above the bridge. Heat may be increased, if necessary, when the flame does not show above the chimney. The period of burning the vapours must be 13 min.  $\pm$  1 min.

When the vapours cease to burn and no further blue smoke can be observed, the burner is readjusted and heating is continued as at the beginning so as to make the bottom and lower part of the sheet-iron crucible a cherry red, and this is maintained for exactly 7 minutes. The total period of heating must be 30 min.  $\pm$  2 min., which constitutes an additional limitation on the tolerances for the pre-ignition and burning periods. No difficulty should be experienced in carrying out the test exactly as directed with a Méker burner of the type named, using town gas (about 500 B.Th.U.s.) with the top of the burner about 2 in. below the bottom of the crucible. The time periods must be observed with whatever burner and gas is used.

The burner is removed, the apparatus is allowed to cool until no smoke appears and the cover of the Skidmore crucible is removed; this takes about 15 minutes. The porcelain or silica crucible is removed with heated tongs and cooled finally in a desiccator before being weighed. The percentage of carbon is calculated on the original sample and returned as "Carbon Residue (Conradson)."

## Asphaltenes

The weight of the original sample must be accurate to within 5 mgm., and tests must be made in duplicate until the percentages of carbon residue do not differ by more than  $\pm 10$  per cent. from an average.

### ASPHALTENES (HARD ASPHALT)

Sufficient of the sample (but not over 10 gm.) to give a weight of precipitated hard asphalt not exceeding 0.25 gm. is dissolved in petroleum spirit, which must be as hot as possible. For every gram of sample, 10 ml. of petroleum spirit are to be used. The oil and solvent are thoroughly mixed and allowed to stand for 24 hours in the dark, after which the solvent is poured off through an 11-cm. pleated filter paper and the residue washed with successive quantities of hot petroleum spirit, being incorporated by means of a glass rod. The washings are passed through the filter paper and the process is continued until the washings are practically colourless. The residue is then washed with boiling 95 per cent. alcohol until it is free from paraffin wax, and is then dissolved in crystallisable benzene, the solution is poured through the filter and the filtrate is collected in a weighed conical flask. The filter is washed free from all hard asphalt and the washings are collected in the conical flask. The benzene is distilled off on a water-bath, the hard asphalt is dried in the steam oven for 2 hours, with occasional removal of the vapour from the flask by a current of air, cooled and weighed.

*Note.*—The quantity of hard asphalt precipitated is largely affected by the solvent/oil ratio. Since "hard asphalt" is an indeterminate substance, a constant ratio of solvent to oil must be maintained in the determination.

The petroleum spirit must conform to the following specification :

- (a) The specific gravity at 60° F. must be between 0.680 and 0.690.
- (b) At least 90 per cent. must distil between 60° and 80° C. when tested by the method (I.P. G.3) for the distillation of gasoline.
- (c) The content of aromatic hydrocarbons, as determined by the aniline-point method, must not exceed 0.5 per cent. In "Standard Methods," 1924, it is specified that the spirit is to be freed from aromatic hydrocarbons "by treatment with its own volume of 98 to 100 per cent. sulphuric acid." This requirement is omitted in the third edition, 1935.

Removal of aromatic hydrocarbons is carried out when making the aniline-point test by shaking 1 volume of spirit with 3 volumes of concentrated sulphuric acid (99 per cent.  $\pm 0.5$ ) in a stoppered 500-ml. bottle for 30 minutes in a mechanical shaker. The mixture is allowed to stand for at least one hour until separation is complete, after which the spirit is separated from the acid.

# Fuel Testing

## POUR-POINT

This test is designed to determine the lowest temperature at which an oil will pour or flow when it is chilled without disturbance, under definite prescribed conditions.

*Apparatus* (Fig. 48).—The test jar A is of clear glass, cylindrical in shape, with a flat bottom, approximately 30 mm. diameter inside and 115 to 125 mm. high.

The thermometer B is the I.P. "Cloud and Pour" and must conform to the specification.

The jacket D may be of glass or metal; it must be water-tight, cylindrical in shape, flat bottomed, about 115 mm. high, with inside diameter from 9.5 to 12.5 mm. greater than the outside diameter of the test jar.

E is a disc of cork or felt 6 to 7 mm. thick and of the same diameter as the jacket.

The ring-gasket F is about 5 mm. thick, and is made to fit snugly round the outside of the test jar and loosely inside the jacket. The gasket may be of cork, felt or other suitable material, elastic enough to cling to the test jar and hard enough to hold its shape;

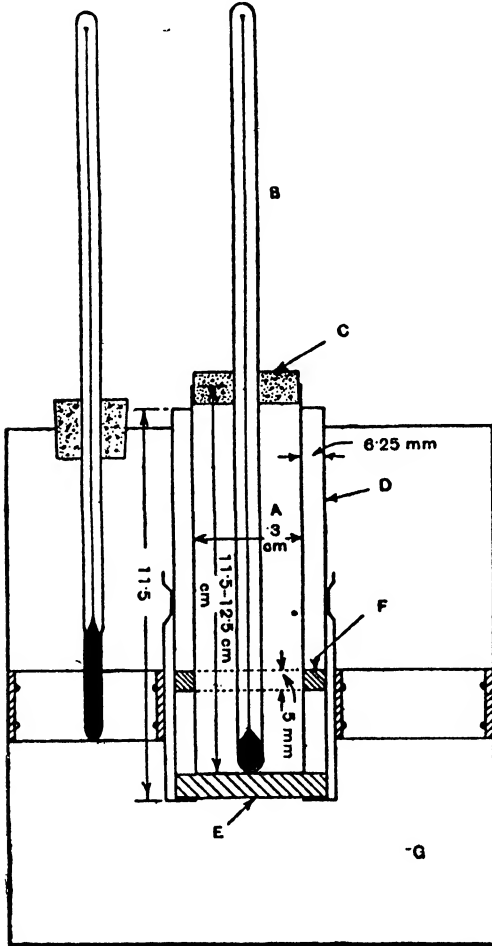

FIG. 48.—Pour-Test Apparatus.

its purpose is to prevent the test jar from touching the jacket.

The cooling bath G is of a type suitable for obtaining the required temperature. The size and shape of the bath are optional, but a support suitable for holding the jacket firmly in a vertical position is essential. For determining pour-points below 50° F., two or more baths should be available.

Suitable freezing mixtures are :

## Pour-Point

For temperatures down to 50° F., ice and water.

For temperatures down to 10° F., crushed ice and salt.

For temperatures down to — 15° F., crushed ice and calcium chloride crystals.

For temperatures down to — 70° F., solid carbon dioxide and acetone or gasoline.

*Method.*—The oil is poured into the test jar to a height of between 51 and 57 mm. If necessary, the oil should be heated in a water-bath just sufficiently to allow of its being poured into the jar. The test jar is then tightly closed by the cork C which carries the thermometer in a vertical position in the centre of the jar, the bulb being immersed so that the beginning of the capillary is 3 mm. below the surface of the oil.

The oil is heated, without stirring, to 115° F. in a bath whose temperature does not exceed 118° F. It is then cooled to 90° F. in air or in a water-bath whose temperature is approximately 77° F. If the pour-point is expected to be below — 30° F., the oil should be heated as above with the “high” cloud- and pour-test thermometer in position, cooled to 60° F., and the “low” cloud- and pour-test thermometer placed in position. Oils with a pour-point of above 90° F. are to be heated to 115° F. or to a temperature 15° F. above the expected pour-point with the “high” cloud- and pour-test thermometer in position, and the test-jar immediately placed in the jacket. The disc E is placed at the bottom of the jacket D and the test-jar, with the ring-gasket F 25 mm. above the bottom, is inserted in the jacket; the disc, gasket and inside of the jacket must be clean and dry.

After the oil has cooled enough to allow the formation of crystals of paraffin wax, great care must be taken not to disturb the oil nor to permit the thermometer to shift in the oil. Any disturbance of the spongy network of crystals will lead to low and fictitious results.

The temperature of the cooling bath is maintained at from 30° to 35° F. The jacket, containing the test-jar, must be supported firmly in a vertical position in the cooling bath so that not more than 25 mm. of the jacket projects out of the cooling medium.

Beginning at a temperature 20° F. before the expected pour-point, at each reading of the thermometer which is a multiple of 5° F., the test jar is carefully removed from the jacket and tilted just enough to see whether there is a movement of the oil; the operation of removal and replacement must not occupy more than 3 seconds. If the oil has not ceased to flow when its temperature has reached 50° F., the test jar is placed in the jacket in a second bath maintained at a temperature of 0° to 5° F. If the oil has not ceased to flow when the temperature has reached 20° F., the test



## Fuel Testing

jar is placed in a third bath maintained at a temperature of  $-30^{\circ}$  to  $-25^{\circ}$  F. For the determination of very low pour-points, additional baths should be maintained at temperature differentials of about  $30^{\circ}$  F. In each case the test jar must be transferred when the temperature of the oil reaches a point  $50^{\circ}$  F. above the temperature of the new bath. At no time must the test jar be placed directly in the cooling medium. As soon as the oil in the test jar does not flow when the jar is tilted, the jar is held in a horizontal position for exactly 5 seconds, as measured by an accurate timing device, and observed carefully. If the oil shows any movement under these conditions, the test jar is immediately replaced in the jacket and a test for flow is repeated at the next temperature  $5^{\circ}$  F. lower.

The test is continued until a point is reached at which the oil shows no movement when the jar is held horizontally for exactly 5 seconds. Certain lubricating oils tend to move as a whole, and should be very closely observed. The reading of the thermometer at this temperature, corrected for error if necessary, is recorded. The pour-point is taken as the temperature  $5^{\circ}$  F. above this solid point.

When it is known that a sample has been heated to a temperature above  $118^{\circ}$  F. during the preceding 24 hours, or if the history of the sample in this respect is not known, the sample must be held in the laboratory for 24 hours before being tested, unless three consecutive tests on the same sample in the same test jar are consistent.

## ASH

The ash is determined by evaporating a suitable quantity of oil to a small volume, transferring to a weighed platinum dish and cautiously continuing the evaporation to dryness, finally igniting until all traces of carbon have disappeared.

The actual quantity of oil to be used is dependent upon the amount of ash, but generally not less than 250 ml. should be taken.

## CALORIFIC VALUE AND SULPHUR

Determined by burning a known weight of the fuel in a bomb calorimeter in oxygen at a pressure of not less than 25 atmospheres. For details, consult Chapters III and V.

## CHAPTER XIII

### TECHNICAL PYROMETRY

THE importance in industry of accurate measurement and control of temperature is great and increasing: heat is expensive, and since the measurement of quantity of heat is based on the measurement of temperature, pyrometric apparatus is an investment which is necessary to enable an important item of the costs of production to be controlled, and which, if properly employed, is capable of paying heavy dividends.

The range of temperature and the conditions of measurement are so varied that a large number of types of instrument, utilising almost every thermal property, have been devised, but, broadly speaking, temperature measurement is effected in one of two ways:

- (1) The material whose temperature is required is associated with an indicating substance which becomes, from the thermal point of view, a part of the material and indicates, by some physical property, its own temperature.
- (2) The heat radiated is analysed or measured.

The first method is most commonly employed, the second is applicable only to solids, liquids and dense vapours, and is the only method available for measuring extremely high temperatures, and for dealing with inaccessible bodies.

In the following discussion, the subject of temperature measurement is dealt with on broad lines, no attempt being made at detailed treatment. For further information, the reader is recommended to study the works listed in the Bibliography at the end of this chapter.

#### MERCURY-IN-GLASS THERMOMETERS

These may be used for the measurement of temperatures up to 550° C. (1020° F.), and are often graduated over a limited range, e.g. 180° to 550° C., 270° to 360° C., with an enlargement of the capillary between the zero and the commencement of the scale being provided. Unless such a thermometer is used totally immersed (i.e. with the bulb and mercury column heated to a uniform temperature), a serious unknown error may be introduced owing to the enlargement being at a temperature below that of the bulb. It is therefore

## Fuel Testing

preferable to use continuous-scale instruments where partial immersion conditions are necessary, as is general in technical work.

Mercury thermometers may be calibrated for total or partial immersion; this is stated on the stem of the instrument, and while, under favourable conditions, the total immersion thermometer is more accurate, favourable conditions are not often realised, so that calibration for partial immersion is generally to be preferred. Should a total-immersion instrument be employed under partial-immersion conditions, the necessary correction for exposed mercury column is given by the formula:  $\delta t = 0.000143n(T - t)$ , where  $\delta t$  is the correction to be added,  $n$  is the number of degrees exposed, and  $T$  and  $t$  are respectively the indicated temperature and the temperature of the emergent stem taken half-way up the exposed column.

For works purposes, special mercury thermometers are used. Where thermometers are to be permanently fixed, they are made up in metal sheaths and screwed into position at appropriate points. It is always desirable, and often essential, that thermometers should be fixed in special pockets which are screwed or welded into the material of the plant. In the latter category are instruments in pipe-lines or vessels handling high pressure steam. Neglect of this precaution may have serious consequences, ranging from the shutting down of plant to loss of life.

To reduce the lag caused by an air-space between the bulb of the thermometer and the pocket, the latter should be filled with mercury, oil or powdered graphite according to circumstances.

## DISTANCE-THERMOMETERS

These enable temperatures of widely separated points to be measured, the indicating or recording portions of the instruments being grouped at some convenient central point so that the readings may be more conveniently taken.

A distance-thermometer may depend for its operation either on the increase in volume of a liquid or gas, or on increase in vapour pressure resulting from increase in temperature. The former, or "expansion" type of thermometer, has a uniform scale, the latter, a non-uniform scale, the scale becoming more open as the temperature rises.

A thermometer of the expansion type consists of a metal bulb joined by a capillary tube to an indicating or recording mechanism, usually based on the Bourdon principle, which depends on the tendency of a curved tube with a closed end to straighten on the application of internal pressure. The bulb and capillary may be filled with a liquid, or with a gas under pressure, the pressure exerted by the working fluid being used as a measure of the tem-

## Thermo-Electric Pyrometers

perature. Since the increase of pressure (or volume) with temperature is practically uniform, an evenly divided scale is obtained. The working fluids may be alcohol (for temperatures up to 200° C.), mercury (up to 550° C.), or nitrogen (up to 425° C.).

Should the capillary and gauge be heated to a temperature differing considerably from that at which the instrument was calibrated, errors will arise ; therefore the volume of capillary and gauge should be as small as possible.

In the vapour pressure type of distance-thermometer, the pressure developed depends only on the temperature of the free surface of the liquid, and the free surface must always be within the bulb. Under such conditions, changes in the temperature of the gauge and capillary are without appreciable effect on the readings. Since the vapour tension of a liquid rises more rapidly than the temperature, the scale of a vapour pressure thermometer is unequally divided. The available range of a thermometer of this type is included between the boiling-point and the critical temperature of the filling liquid.

The advantage of the vapour pressure thermometer over the liquid- or gas-pressure instrument is obvious, since it is difficult to ensure that the capillary and gauge shall be maintained at a reasonably uniform temperature, in a boiler room, for example.

Both types of thermometer may be indicating or recording. Distance-thermometers are less accurate than mercury-in-glass thermometers on account of the mechanical indicating and recording mechanism and because of the necessity for using relatively large and heavy bulbs. In common with all industrial thermometers, unless they are used under the same conditions as those in which they were calibrated, the readings of distance-thermometers are liable to serious errors.

## THERMO-ELECTRIC PYROMETERS

In these instruments, advantage is taken of the well-known fact that when two dissimilar wires are joined in a closed circuit, if the junction be heated, an E.M.F. is set up. Thus if two wires, one of iron and the other of constantan, be connected in a closed loop, and if one junction be heated to 500° C., the other being maintained at 0° C., an E.M.F. of 27 millivolts will result, the iron being positive to the constantan.

A thermo-electric pyrometer outfit consists of a thermo-couple formed of two dissimilar wires fused together at one end, and connected at the other ends to separate leads which pass to a suitable type of galvanometer by which the potential difference arising when the couple is heated, may be measured.

The readings may be in millivolts, or direct in degrees Centigrade

## Fuel Testing

or Fahrenheit, and the galvanometer may be made indicating or recording.

Theoretically, any pair of metals might be used, but for practical reasons the selection is limited to couples which most nearly fulfil the following requirements :

- (1) Resistance to corrosion.
- (2) As nearly as possible linear variation of E.M.F. with temperature.
- (3) As large an E.M.F. as possible should be developed.
- (4) Constancy of calibration.
- (5) Reproducibility. This is less important in the laboratory than on the works ; many couples may be employed, several being operated on one indicator, and the confusion that would arise from the necessity for using a separate calibration curve for each couple is more easily imagined than described.

The couples which are commonly used and the ranges for which each is available are given in Table XXIII.

TABLE XXIII

COMPOSITION, MAXIMUM TEMPERATURE AND THERMO-E.M.F. OF THERMO-COUPLES <sup>1</sup>

Material.	Composition of Alloy.	Maximum Temp. °C.		Approximate Thermo-E.M.F. Microvolts per °C.
		Average.	Intermittent.	
Copper-Constantan	60 Cu, 40 Ni	300	600	56
Chromel*-Eureka .	{ 90 Ni, 10 Cr } { 40 Ni, 60 Cu }	700	900	75
Iron-Constantan .	60 Cu, 40 Ni	750	1000	57
Nickel, Nickel-chromium *	90 Ni, 10 Cr	1000	1300	20
Chromel-Alumel * .	{ 90 Ni, 10 Cr } { 94 Ni, 2 Al, } Si and Mn }	1200	1350	40
Platinum-Platinum rhodium .	87 Pt, 13 Rh	1450	1700	11
Platinum-Platinum iridium . . .	90 Pt, 10 Ir	1000		12

\* Hoskin's alloy.

Platinum-platinum rhodium thermo-couples are more durable and may be used at higher temperatures than those of other metals, but the cost is high and the E.M.F. low. On account of the high

## Thermo-Electric Pyrometers

price of platinum and its alloys, couples are made from 0.5 mm. wires, and are therefore fragile ; furthermore the low E.M.F. necessitates the use of sensitive, and therefore delicate and expensive indicators or recorders. For these reasons base metal thermo-couples are much used, and for temperatures up to 1000° C. are satisfactory. Owing to the relatively low first cost of the material, stout wires from 1.5 to 3.0 mm. are used, with consequent increase in mechanical strength. The additional sectional area of the wires may, however, cause the junction to be cooled owing to conduction of heat from it and serious errors may arise.

Thermo-couples may be made by twisting the ends of the wires tightly together and fusing in a blow-pipe flame, or by striking an arc between the ends to be joined. The wires are insulated by being passed through silica capillary or through twin-bore silica tubing, and the couple is then ready for mounting. Protection from mechanical damage and from contact with furnace gases is necessary, otherwise corrosion and change in electrical characteristics due to absorption of impurities will be set up. To protect the couple from furnace gases, a porcelain sheath glazed externally may be employed ; this being fragile should be protected from mechanical damage by an outer tube of metal such as a non-scaling steel, unless the pyrometer is to be fixed in the wall of a furnace and subjected to direct flame action, in which case the outer sheath may be of fireclay or some other suitable refractory. The ends of the wires are led to terminals fixed to the end of the outer protecting tube. Although a sheath is necessary for the reasons given, it is an unfortunate necessity, since, on account of the extra heat-capacity, the sensitivity of the pyrometer is reduced and the response to rapid changes in temperature becomes slower.

Since the E.M.F. generated depends on the difference in temperature between the hot junction in the furnace and the cold junction at the head of the couple, variation in the temperature of the latter will result in a fluctuating E.M.F., even though the hot junction is maintained at a uniform temperature. It is necessary, therefore, to employ some means of cold junction control, otherwise serious errors may arise. Indicators and recorders are often calibrated to give correct readings when the hot junction is in circuit, provided that the pointer is set to the cold junction temperature before the hot junction is connected. Hence when an appreciable change in the cold junction temperature takes place, the positive lead to the indicator is disconnected and the zero is reset. As an alternative, a bimetallic compensator may be fitted, whereby the readings are automatically corrected.

By using compensating leads formed of alloys which have similar thermo-electric constants to the thermo-couple, the cold

## Fuel Testing

junction may be transferred from the head of the thermo-couple to a point where fluctuations of temperature are less, or if the leads are short, to the indicator, where the temperature can be measured by a thermometer. Compensating leads enable shorter couples to be used, and permit of accurate cold junction control. The temperature of the cold junction may be maintained steady to within two or three degrees by means of a vacuum flask filled with oil, or by burying it at a depth of about 10 ft., preferably beneath the floor of a building, but if special accuracy is required, some kind of thermostat must be employed.

The connections from the terminals of the junction box to the indicator or recorder are made with copper wires, which should be of ample diameter to ensure low line resistance. Wood and Cork (*loc. cit.*) recommend that the copper leads should be at least 12 gauge if the distance between the cold junction and the indicator is long.

It should be noted that thermo-couples give *point* temperatures, i.e. the temperature immediately at the couple tip, and if the average temperature over a considerable area is required, either a number of couples must be installed or some other type of apparatus must be adopted.

## Calibration of Thermo-couples

A convenient method of checking a single thermo-couple is to heat it in a furnace close to a wire of known melting-point through

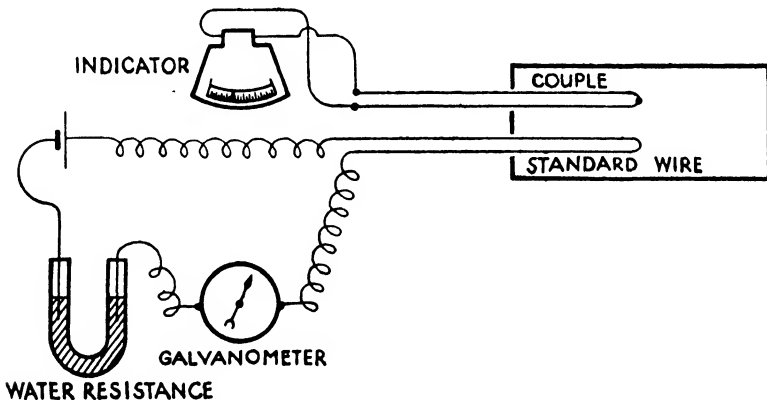

FIG. 49.—Diagram Showing Arrangement for Calibration of Thermo-couples.

which an electric current is passed. The apparatus may be assembled as shown in Fig. 49. A very small current (regulated by a water resistance) is passed through the standard wire, and a galvanometer or spare temperature indicator shows by a deflection of the pointer that the continuity of the circuit is unbroken, and that the current is passing. The temperature of the furnace is slowly

## Resistance Pyrometers

raised till, when the melting-point of the standard wire is reached, the circuit is broken by the fusing of the wire, causing the galvanometer needle to give a sudden kick. When this occurs, the reading of the indicator connected to the thermo-couple is taken, and compared with the known melting-point of the standard wire.

Suitable wires for standardising thermo-couples are: Tin m.pt. 231.8° C.; Lead m.pt. 327.5° C. (reducing atmosphere); Aluminium m.pt. 660.0° C.; Silver m.pt. 960.5° C. (reducing atmosphere), and Gold m.pt. 1063° C.

When one couple has been checked in this manner, it may be used as a reference standard for testing others.

An alternative method is to determine freezing-point curves of selected pure substances; the thermo-junction (suitably protected) is supported in a crucible of the molten reference material, and readings are taken at regular, short, intervals of the temperature shown by the indicator. When the freezing-point is reached, the temperature will remain constant for several intervals of time. It is important that when this method of calibration is employed, each crucible or pot of reference substance should be provided with its own protecting sheath for the thermo-junction, otherwise if a single sheath is used and transferred from bath to bath, contamination is certain to occur.

### RESISTANCE PYROMETERS

These instruments depend on the fact that the resistance of an electrical conductor is a function of the temperature, and in general is related to it by an equation of the form  $R = A + BT + CT^2$ . Since electrical resistance is susceptible of very accurate measurement, this method may be employed for very precise work where temperatures are to be measured to a fraction of a degree. Furthermore, by suitably disposing the resistance wire of the pyrometer, the average temperature over a considerable area may be determined.

The resistance element is composed of platinum wire, generally wound on a thin mica former, suitably cased and provided with terminals. The platinum wire must be extremely pure, as traces of impurities seriously affect the relation between  $R$  and  $T$ ; consequently protection of the element from contact with furnace gases is essential. The resistance of the coil at different temperatures is measured on a galvanometer, embodying a modified form of Wheatstone Bridge, and is compared with other resistances which do not change with temperature, their value being so adjusted that the bridge is balanced at the commencing temperature of the range of the galvanometer. Any increase in temperature of the coil causes the galvanometer pointer to move over a scale calibrated



## Fuel Testing

directly in temperature. The current necessary to operate the system is supplied by a small accumulator.

Such an instrument may be used for all temperatures from  $-200^{\circ}$  to  $+540^{\circ}$  C. ( $-330^{\circ}$  to  $+1000^{\circ}$  F.) with an accuracy of within 1 per cent. of the range.

## OPTICAL PYROMETERS

Optical pyrometers depend on the fact that when a body is heated to a sufficient temperature, it emits visible radiations whose intensity may be correlated with the temperature. The relation between the intensity of the radiation and the temperature of the body depends on the nature of the surface. Thus the intensity of the light emitted from a clean surface of molten copper in the open would be much less than that from a block of carbon at the same temperature. The brightness of the copper surface is not merely a function of its temperature, but is modified by reflection of the surroundings, whereas the carbon surface being a non-reflector is bright solely by virtue of the temperature to which it is heated. The carbon surface is a near approach to a true "black body" in that the intensity of the emitted light is a true measure of the temperature, no light being reflected from the surface of the material. Black body conditions are closely approached when a heated object in an enclosure at the same temperature is viewed through a small hole in the wall of the chamber, e.g. an ingot of steel in a furnace, in temperature equilibrium with it, observed through a sight-hole.

Optical pyrometers are usually calibrated for black body conditions, the consequence being that if such an instrument be used under other circumstances, e.g. if sighted on a reflecting surface such as that of molten iron flowing from the tap-hole of a blast furnace, the observed temperature would be seriously below the true value. On the other hand, the error would be constant, so that for control purposes, under uniform conditions, such a pyrometer might be employed.

### Disappearing Filament Pyrometer

In this instrument, the brightness of the light from the heated body is compared with that of a standard lamp whose brightness is controlled by varying the current passing through the filament.

The optical system of the apparatus made by the Foster Instrument Co. is illustrated in Fig. 50. A focussed image of a small part of the hot body surface B is formed in the same plane as the lamp filament F. The eye A of the observer views this image and the lamp filament through the eyepiece E. For temperatures between  $700^{\circ}$  and  $800^{\circ}$  C. ( $1292^{\circ}$  and  $1472^{\circ}$  F.) this represents the



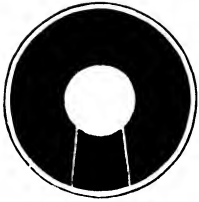

Correct.

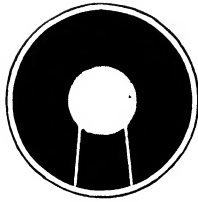

Filament too hot.  
High reading.



Filament too cold.  
Low reading.

FIG. 51.—The Disappearing Filament.  
*(By courtesy of the Foster Instrument Co.)*



FIG. 52.—The Féry Radiation Pyrometer.  
*(By courtesy of the Cambridge Instrument Co. Ltd.)*

[To face page 235.]

## Total Radiation Pyrometers

whole system. Above  $800^{\circ}\text{C}$ . the brightness may tend to dazzle, so a monochromatic red glass C is interposed, by means of which the matching may be extended up to, say,  $1450^{\circ}\text{C}$ . ( $2642^{\circ}\text{F}$ .). This monochromatic glass also cuts out differences in colour, and makes the comparison purely a matter of intensity.

The instrument is sighted on the hot body, the telescope is adjusted so that the filament of the lamp is also in focus, and the heating current is regulated until the image of the filament becomes merged in and indistinguishable from that of the body whose temperature is required. The temperature of the filament is read directly on a specially calibrated millimeter.

To enable the instrument to be used for higher temperatures than  $1450^{\circ}\text{C}$ . which would cause damage to the lamp filament, an absorbing glass D is placed between the lamp and the objective of the telescope. The apparent brightness of the hot body is thus reduced, and the lamp filament need not be heated to the same temperature to obtain a match. The millimeter is calibrated so that the hot body temperature may be read directly as before.

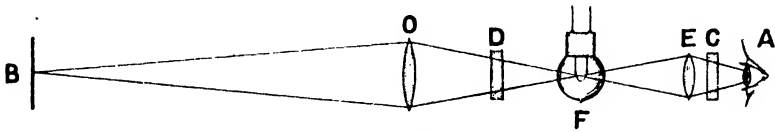

FIG. 50.—The Foster Disappearing Filament Pyrometer.

(By courtesy of the Foster Instrument Co.)

The Cambridge optical pyrometer photometrically compares the intensity of monochromatic light from the heated object with the intensity of a beam of similar light from a standard lamp.

While optical pyrometers as described above are suitable for determining temperatures above the capabilities of other types of instruments, and also of small bodies, they suffer from the disadvantage that being dependent on visual comparison of intensity light, they cannot be made self-recording.

## TOTAL RADIATION PYROMETERS

Whereas in the optical pyrometer the intensity of radiation covering a restricted range of wave-lengths is measured, in the type to be described, the intensity of the radiation as a whole is measured by focussing it on a small thermo-couple.

### The Féry Radiation Pyrometer

The Féry Radiation Pyrometer (see Fig. 52) consists of a telescope containing a concave mirror which serves to bring the heat rays to a focus on the couple. The optical arrangement of the

## Fuel Testing

telescope is illustrated in Fig. 53. The heat rays A from the furnace are received on the concave mirror C, which brings the rays to a focus at N. Looking through the eyepiece E the observer sees an image of the furnace in the small mirror M, and is able to direct and focus the telescope exactly on the required spot. The thermocouple is situated behind a small hole in the mirror M and becomes

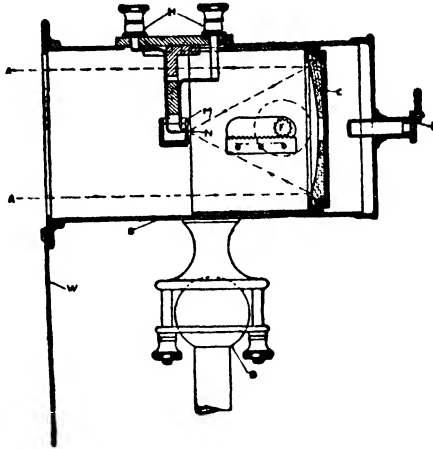

FIG. 53.—Optical Arrangement of the Féry Pyrometer.  
(By courtesy of the Cambridge Instrument Co. Ltd.)

heated by the rays passing through the hole, its temperature being read off on a directly reading galvanometer connected to the terminals on the telescope.

The mirror M consists of two small, semi-circular, wedge-shaped mirrors fixed together. If the instrument is correctly focussed, the appearance is as shown in the centre diagram of Fig. 54 in which

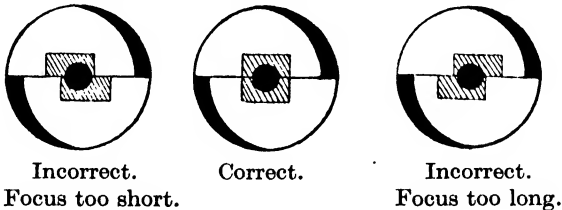

FIG. 54.—Focussing the Féry Radiation Pyrometer.  
(By the courtesy of the Cambridge Instrument Co., Ltd.)

the outer circle represents the mirror, the shaded portion the reflected image of the hot body on which the telescope is sighted, and the black centre the sensitive element of the pyrometer, which must be covered by the image of the hot body. If the focus is incorrect, the image appears divided into two unaligned parts, the appearance being as in the left-hand diagram when the focus is too short and as

## Total Radiation Pyrometers

in the right-hand diagram when it is too long. By rotating the knurled head attached to the pinion F the concave mirror C is moved back or forward so that the half-images appear to slide on one another, until coincidence is obtained, when the focus is correct. The temperature is then read off on the indicator. The size of the body or aperture sighted on, and the distance of the telescope from it do not, within wide limits, affect the temperature readings; but the body sighted on should be at least 1 in. in diameter for every 2 ft. between the telescope and the object, to ensure that its image will overlap on all sides the sensitive element in the telescope.

In order to allow of temperature readings being taken on a furnace without ingress of cold air due to opening a door or sight-hole, it is sometimes convenient to fix a silica or porcelain tube closed at one end in the wall of the furnace, the closed end of the tube being carried well within, to the point at which the temperature is required: the telescope is then sighted on the closed end of the tube which is maintained at the furnace temperature.

A similar arrangement may be used in measuring the temperature of a crucible of molten metal in the open.

### The Foster Radiation Pyrometer

The Foster Radiation Pyrometer is a fixed-focus instrument, and is illustrated in Fig. 55. The thermo-couple D and the pyro-

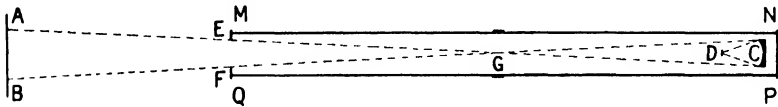

FIG. 55.—The Foster Fixed-Focus Radiation Pyrometer.

(By courtesy of the Foster Instrument Co.)

meter opening are placed at conjugate foci of the concave mirror C; consequently, provided the size of the source of heat is such that it completely fills the base of the cone AB, whose apex is at G, the energy received at G will be, apart from increased absorption due to air, independent of the distance. The maximum allowable distance between G and the hot body is ten times the diameter of the latter for all instruments except that working to 1800° C., where the multiple is twelve.

Two other radiation pyrometers may be referred to, both of which operate on the same principle, namely, the obscuration of the source of heat by causing the light from it to pass through a solution of a dye or coloured glass, the thickness of the coloured material necessary to blot out the light being used as a measure of the temperature. In one of these instruments, a wedge of coloured glass is gradually moved across the line of vision until the light from the heated object

## Fuel Testing

just vanishes, while in the other the length of a column of a solution of a dye is gradually extended until the same thing happens. By means of a scale on the instrument, working against a fixed pointer, the temperature of the heated object is read off. While these instruments may, in the hands of some observers, give reasonable results, in the experience of the Author this is not always so. For owing to the retention of the image of (say) a peephole in the back of a boiler furnace, the Author has found that he cannot obtain any consistency with instruments of this description, in fact, on occasion, he has found that the heated object apparently never became obscured, even though the wedge or column of dye had been extended to its utmost and the indicated temperature was far above that which could possibly have been correct.

## FUSION PYROMETERS

Fusion pyrometers depend on the use of pieces of material of known melting-point; a number of such pieces covering a definite melting range are introduced into the furnace whose temperature is adjusted to the desired temperature as indicated with reference to the behaviour of the test pieces. Thus, if it were required to carry out a furnace operation at between 900° and 940° C., three such test pieces melting at 900°, 920° and 940° C. respectively might be used, and the heating regulated so that the 900° and 920° C. pieces melted, while the 940° C. piece did not.

TABLE XXIV

MELTING-POINTS OF SÉGER CONES

Cone No.	°C.	°F.	Cone No.	°C.	°F.	Cone No.	°C.	°F.	Cone No.	°C.	°F.
022	600	1112	07a	960	1760	9	1280	2336	29	1650	3002
021	650	1202	06a	980	1796	10	1300	2372	30	1670	3038
020	670	1238	05a	1000	1832	11	1320	2408	31	1690	3074
019	690	1274	04a	1020	1868	12	1350	2462	32	1710	3110
018	710	1310	03a	1040	1904	13	1380	2516	33	1730	3146
017	730	1346	02a	1060	1940	14	1410	2570	34	1750	3182
016	750	1382	01a	1080	1976	15	1435	2615	35	1770	3218
015a	790	1454	1a	1100	2012	16	1460	2660	36	1790	3254
014a	815	1499	2a	1120	2048	17	1480	2696	37	1825	3317
013a	835	1535	3a	1140	2084	18	1500	2732	38	1850	3362
012a	855	1571	4a	1160	2120	19	1520	2768	39	1880	3416
011a	880	1616	5a	1180	2156	20	1530	2786	40	1920	3488
010a	900	1652	6a	1200	2192	26	1580	2876	41	1960	3560
09a	920	1688	7	1230	2246	27	1610	2930	42	2000	3632
08a	940	1724	8	1250	2282	28	1630	2966			

## The Siemens Pyrometer

Séger cones consist of small three-sided pyramids each  $2\frac{1}{2}$  in. high and  $\frac{1}{2}$  in. wide at the base. They are made of mixtures of china clay, felspar and flint in proportions varying according to the desired melting-points, and are numbered in a series. The relation between the numbers and the nominal melting-points is given in Table XXIV. The temperature of the furnace is taken to be that of the melting-point of the cone which just "squats," i.e. whose tip bends over and touches the base. Thus, in Fig. 56 the temperature of the furnace in which the cones illustrated was heated, would be taken as the melting-point of the middle cone, viz. No. 8.

In using such cones it is preferable to record the serial number of the cone which squats rather than the melting-point taken from the table, as the precise squatting temperature is dependent on the rate and conditions of heating. The Séger cone is much used in the clay

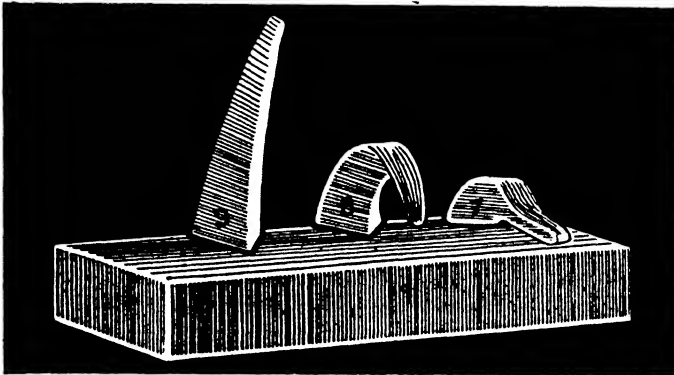

FIG. 56.—Séger Cones.

(By courtesy of A. Gallenkamp & Co., Ltd.)

industries, and temperatures are frequently recorded in terms of the serial number of the cone which just melts in the furnace.

### THE SIEMENS PYROMETER

A convenient works method for determining the approximate temperature of a furnace is to employ a modification of the Siemens pyrometer. A block of metal of known weight and specific heat is placed in and allowed to attain temperature equilibrium with the furnace, after which it is quickly removed and dropped into a known weight of water in an insulated container. From the known water equivalent of the apparatus, the temperature of the furnace may be calculated. An apparatus such as this, rough though it may be, is often more convenient than a more costly installation, and it is to be remembered that a rough attempt at furnace control is better than no control at all; moreover, preliminary results obtained with a



## Fuel Testing

home-made apparatus will sometimes serve to convince the management that the expense incurred in installing better instruments is warranted. Figures, in fact, speak more audibly than words.

### MEASUREMENT OF THE TEMPERATURE OF GASES FLOWING IN PIPES AND FLUES

It is by no means easy to determine with reasonable accuracy the temperature of a gas flowing in a pipe or flue. The temperature of the walls of the duct is generally different from that of the gas, consequently interchange of heat takes place between the pyrometer and its surroundings, and the temperature indicated is intermediate between the temperature of the gas and that of the walls of the flue. If the reading of the pyrometer is steady, the true temperature of the gas may be calculated fairly accurately by means of a heat balance, bearing in mind that the loss of heat by the pyrometer by radiation and convection is balanced by the gain of heat from the gas, i.e.

$$H_{rw} + H_k = H_{gr} + H_{gc},$$

where,  $H_{rw}$  = heat lost by radiation of pyrometer to walls,

$H_k$  = heat lost by convection of pyrometer to walls,

$H_{gr}$  = heat gained by radiation from gas,

$H_{gc}$  = heat gained by convection from gas, all per unit area of the pyrometer.

If (as is usually the case)  $H_k$  and  $H_{gr}$  are small in comparison with the other terms,  $H_{rw}$  may be equated to  $H_{gc}$ .  $H_{gc}$  may be calculated from Schack's equation

$$H = \frac{8.7(G)^{0.56}}{D^{0.44}},$$

where  $H$  = B.Th.Us. per sq. ft. per hour per deg. F.,

$G$  = mass velocity of gas in lb. per sq. ft. per sec.,

and  $D$  = diameter of the pyrometer in inches.

$H_{rw}$  may be calculated from the ordinary radiation equation,

$$H_{rw} = 1.73 \times 10^{-9} E(T_p^4 - T_w^4),$$

where  $H_{rw}$  = B.Th.Us. per sq. ft. per hour,  $E$  is the emissivity coefficient, and  $T_p$  and  $T_w$  are the absolute temperatures of the pyrometer and the walls on the Fahrenheit scale (degrees Rankine).

Hence, if  $t_g$  and  $t_p$  = the respective temperatures of the pyrometer and the gas in deg. F.,

$$(t_g - t_p) \frac{8.7G^{0.56}}{D^{0.44}} = 1.73E \times 10^{-9} (T_p^4 - T_w^4).$$

*Example.*—Dry air is flowing through a circular duct 2 ft. in diameter at 1000 cu. ft. per min. (calculated at 15° C. and 30 in. Hg). A pyrometer an inch in diameter in the air-stream reads 450° C., and the walls of the duct are at 400° C. The emissivities of all materials in the system may be taken as 0.7, and their thermal conductivities may be ignored. Calculate the true temperature of the air.

Rate of flow of air 1000 cu. ft. per min. at 15° C. and 30 in. Hg is equivalent to  $1000 \times \frac{273}{288} \times \frac{762}{760} = 950.6$  cu. ft. at N.T.P. =  $\frac{950.6}{359} = 2.65$  lb.-mols. =  $2.65 \times 28.9 = 76.5$  lb. per min.

$$G = \frac{76.5}{60 \times \pi \times 1} = 0.406 \text{ lb. per sq. ft. per sec.}$$

## Temperature of Gases

$$\text{and } H_{gc} = \frac{8.7 \times (0.406)^{0.56}}{1^{0.44}} = 5.25 \text{ B.Th.U.s. per sq. ft. per hr. per deg. F.}$$

The temperatures of the pyrometer and the walls are, respectively, 842° and 752° F., or 1302° and 1212° Rankine. Equating  $H_{gc}$  to  $H_{rw}$ ,

$$\begin{aligned} (t_g - t_p) 5.25 &= 0.7 \times 1.73 \times 10^{-9} (1302^4 - 1212^4) \\ &= 867 \text{ B.Th.U.s per sq. ft. per hour,} \end{aligned}$$

$$t_g - t_p = \frac{867 \times 1}{5.25 \times 1.8} = 91.7^\circ \text{ C.}$$

Hence, the true temperature of the air = 450 + 91.7, or 542° C.

The error represented by the difference  $t_g - t_p$  may be reduced by one or other of three methods.

(i) By using a suitable shield of low emissivity round the pyrometer.

(ii) By reducing the diameter of the pyrometer. The effect of successive reductions in the diameter of the pyrometer is shown in the following table, which indicates that such a reduction is advantageous quite apart from the fact that loss of heat along the pyrometer is concomitantly reduced. This method may be applied by employing a number of pyrometers of different diameter, plotting their readings against diameter, and extrapolating to zero diameter.

EFFECT OF REDUCING THE DIAMETER OF THE  
PYROMETER ON THE HEAT RECEIVED

Diameter, in.	$1/D^{0.44}$ .
1	1.0000
0.75	1.135
0.50	1.356
0.20	2.030
0.1	2.755
0.05	3.736
0.02	5.59
0.01	7.59

(iii) By increasing the mass-velocity of the gas. In a plant, the mass-velocity of the gas cannot be varied simply to enable more accurate measurement of temperature, hence a "suction" pyrometer is used. In such a pyrometer, a thermo-junction is mounted in a tube and a rapid stream of gas is aspirated over the junction. The theory of the suction pyrometer has been discussed by A. Schack, and several designs of apparatus are described by other authors.<sup>2</sup>

### BIBLIOGRAPHY

- "Dictionary of Applied Physics," 1922, Vol. I, Articles, "Pyrometry."  
 E. Griffiths, "Pyrometers," 1926.  
 W. P. Wood and J. P. Cork, "Pyrometry," 1927.  
 D. M. Liddell, "Handbook of Chemical Engineering," 1922.  
 "Gas Engineers' Handbook," 1934.  
<sup>1</sup> "Technical Data on Fuel," British National Committee, World Power Conference, 4th edn., 1934.  
<sup>2</sup> A. Schack and others, *Journ. Inst. Fuel*, March, 1939, 12.

## CHAPTER XIV

### THE SELECTION OF COAL FOR INDUSTRIAL USES

WHILE it is possible to lay down general rules as to the suitability of coals of certain characteristics for specific uses, and while the results of small scale laboratory tests may be correlated with results obtained on the industrial scale, any rules can be accepted only as broad generalisations. No laboratory test will enable an observer to state with certainty that a particular coal will give the results he is seeking when utilised in a particular plant, nor is it possible to discriminate in the laboratory between the relative values of two or more coals of very similar characteristics. All that can safely be said as the result of such tests is that particular coals are very likely to prove unsuitable, while others are worth trying in the plant. *The final court of appeal must be trial under working conditions in the plant in which it is proposed to use the coal.*

Notwithstanding the limitations mentioned above, the manager of a plant can, by reference to previous results, and the result of small scale tests, derive useful information as to the probable consequences of a change of coal, and he will, as the result of experience, definitely be able to rule out certain coals as unsuitable.

The choice of a coal for any plant is, in the last analysis, a financial question, that coal being chosen which, all factors being taken into consideration, will give the desired results at the lowest overall cost. It follows that coals are employed in various directions in ways which do not commend themselves to the scientist or the fuel technologist. Thus, high-volatile bituminous coals are burned without pre-treatment, owing to their comparative cheapness and convenience, regardless of the fact that in so doing valuable potential by-products are irretrievably wasted, and that the efficiency of utilisation is far below that attainable.

While it is possible to state in general terms the attributes to be sought in a coal for a specific purpose, it must not be forgotten that such rules may necessarily be discounted in practice by reason of limitations imposed by a particular plant or process, and also by considerations of cost.

Speaking generally, the desirable qualities in a coal for industrial use are :

## Selection for Steam Raising

Calorific value should be high, since owing to the concentration of heat, handling and storage costs are minimised; moreover, generally speaking, efficiency of utilisation increases with increase of calorific value.

The mineral ash should be low; with any given coal, the calorific value and the ash content vary nearly inversely with one another, but the relationship is not rigid, since the ash is not a strict measure of the mineral matter in the coal (see p. 115). The inorganic matter is of no direct use and entails extra charges for handling and storage.

The moisture should be low; apart from the cost of handling and storing the water in the coal, its evaporation results in extra loss of heat.

For most purposes, a uniform size of fuel is desirable, the presence of fine dust or large lumps being objectionable. Fine dust fills up the interstices between the lumps and hinders the passage of air when the coal is burnt, while large lumps should be broken before the coal is used, and more fine dust is inevitably produced in the process.

It is also desirable that successive deliveries of coal should be as far as possible of the same quality, as under modern industrial conditions it is of great advantage to operate on uniform raw material, since continued adjustment of any plant to cope with variations in this respect entails lowered efficiency and loss of output.

While these remarks hold good in general, certain special qualities are required in coals to be used for specific purposes, and a brief summary of the desirable qualities which should be sought in coal for several uses is given below.

One rule of general application may be added, unless it is specifically desired to produce a carbonised residue, strongly-caking coals should be avoided; non- or weakly-caking coals will give better results.

### SELECTION FOR STEAM RAISING

In addition to the good qualities described above, the ash should be refractory and infusible in the furnace. Fieldner and Selvig<sup>1</sup> suggested the following classification of coals in respect of clinkering propensities:

*Class 1.*—Coals having refractory ash which softens above 2600° F. (1427° C.). The ash from these coals gives no trouble from clinkering.

*Class 2.*—Coals having ash of medium fusibility, softening between 2200° and 2600° F. (1204° and 1427° C.). The clinkering propensities will depend on the temperature in the furnace, the kind of stoker

## Fuel Testing

and the distribution of the mineral matter in the coal. As the softening temperature of the ash falls, the tendency to the formation of clinker increases approximately in like ratio.

*Class 3.*—Coals having ash which is easily fusible and which softens below 2200° F. (1204° C.). These coals will form a considerable amount of clinker which may spread over the grates if the temperature is high enough.

Where there is differential movement between the layers of the fuel bed (underfeed stokers), the risk of formation of clinker is greater than where the fuel bed is not so churned up (travelling grates).

As regards interpretation of the proximate analysis, much depends on the design of the plant. In any case, a coal which gives a hard and non-porous coke should be avoided as it is not sufficiently free burning to allow of sudden increases in the load on the boiler to be rapidly taken up; moreover, a large excess of air is necessary to avoid excessive carbon loss in the solid refuse. Hence, hard coking coals (generally in Great Britain with volatile matter at 900° C. on the dry ashless coal between 20 and 30 per cent.) should be avoided; also, unless the available draught of the plant is ample, anthracitic coals of between 8 and 15 per cent. volatiles may be unsuitable.

Hand-fired boilers of low furnace volume, which include Cornish, Lancashire, locomotive and Scotch marine boilers, are likely to give smoke with accompanying heavy loss of combustible gases and vapours when high-volatile coals are used; therefore for boilers of these classes, the semi-bituminous coals with volatiles between, say, 12 and 20 per cent., are likely to prove best. Mechanically-fired water tube boilers, on the other hand, can handle with high efficiency coals of more widely varying characteristics.

While low ash is desirable, if the coal is to be used on a travelling-grate stoker, the ash should not be below 7 per cent.; if the ash falls appreciably below this minimum, the links of the grate burn out rapidly, being unprotected from the full heat of the fire by a sufficient layer of ash.

The coal should be free from large lumps (over 3 in. cube), and should contain little dust (below 4-mesh), particularly if intended for use in hand-fired boilers. In addition to the frictional resistance set up in the fuel bed by fines, there is loss of fuel caused by the riddling of the fines through the grate into the ashpit.

The sulphur in coal used for steam raising is becoming of increasing importance. The contribution to the heating value of the fuel by sulphur is small, and the mixture of sulphurous and sulphuric acids formed by its combustion may set up serious corrosion in economisers and air-heaters, and with the advent of the super-

## Selection of Coal

power station, the problem of removing sulphur dioxide and trioxide from the waste gases is assuming serious dimensions.

As already indicated, the calorific value should be as high as possible, and the moisture low.

### SELECTION FOR GAS-PRODUCER OPERATION

The ash should be as low and as infusible as possible. Fusible ash gives rise to serious clinking troubles, and may slag with the lining of the producer. The extra poking to dislodge clinker causes undue loss of carbon in the refuse, and much stirring up of the fuel bed leads to raising of the ash into the hottest part of the fire with increased clinker formation.

A high-volatile coal (35 to 40 per cent. volatile matter on the dry ashless coal at 900° C.) is advantageous as the products of distillation enrich the gas.

Owing to the thickness of the fuel bed in a gas producer, any tendency to choke on the part of the fuel bed is serious; hence strongly caking coals are unsuitable, since by the formation of large lumps of coke, uneven resistance is set up in the bed, and the gasification rate and the quality of the gas in consequence fall off. A slightly caking coal is of advantage, particularly if the coal is dusty or tends to break down into dust when heated.

A closely screened coal is of advantage; a more even distribution of the blast through the fuel bed results, which leads to more even working and better and more constant gas makes.

The moisture content of the coal should be as low as possible; the wetter the coal, the thicker should be the fuel bed in order that the moisture may be evaporated before the coal arrives at the active zones, otherwise the quality of the gas and the thermal efficiency of the plant will suffer. In consequence of the thickening of the fuel bed the resistance to the passage of the blast is increased. The rate of gasification is inversely proportional to the total volume (measured at normal temperature and pressure) per ton of dry fuel gasified, of the crude gas and moisture leaving the generator.

If a clean gas is required, and if the cleaning plant is of small size, it is preferable to operate a producer on coke or on anthracite, as little or no tar has then to be removed.

### SELECTION OF COAL FOR THE PRODUCTION OF METALLURGICAL COKE

Since the coke oven manager is concerned primarily with obtaining a good yield of high-class coke, the gas, tar and ammonia yields are of subsidiary importance, as a rule, little attention is paid to the calorific value of the coal. The coal must be selected for its coking

## Fuel Testing

qualities, due attention being paid to the presence of objectionable constituents such as ash, sulphur and phosphorus.

Speaking generally, the best English coking coals yield from 20 to 30 per cent. of volatile matter on the dry ashless material at 900° C., although in Yorkshire, Lancashire and Scotland coals of higher volatiles are successfully coked, while good coking coals are met with in South Wales, giving from 15 to 20 per cent. volatiles.

The ash in the coke will be to that in the coal in the ratio of from 10 to 8, or 10 to 7; therefore, if it is desired to produce a coke containing not more than 10 per cent. ash, washability tests should be made on coals showing more than 7 per cent. of ash. Since silica in the coke requires the addition of lime as a flux when the coke is used in the furnace, which results in an increase in the amount of slag and the heat lost therein, a ferruginous rather than a siliceous ash is an advantage.

The size is of little importance, since before being charged into the oven the coal is crushed and reduced to 4-mesh or smaller. A slack coal has therefore the advantage that less crushing is required.

Sulphur is objectionable in coal which is to be used for the production of metallurgical coke, and should therefore be as low as possible. Determination of the forms in which the sulphur occurs will give an indication of how much reduction can be effected by cleaning; the higher the proportion of pyritic sulphur, the greater the possible reduction by cleaning. As a rough approximation, it may be taken that the percentage of sulphur in the coke will be the same as that in the coal.

Another objectionable constituent is phosphorus, which is present in the form of calcium phosphate in the mineral matter in the coal. Since, as far as is known, none of the phosphorus is volatilised during coking, the percentage in the coke will be to that in the coal in the ratio of about 100 to 70 or 80.

The permissible limits for sulphur and phosphorus in metallurgical coke depend on the purpose for which the coke is required. For blast furnaces smelting iron which is to be used for steel-making by the basic process, neither sulphur nor phosphorus is particularly deleterious, but if haematite ores are to be smelted, and if the iron is to be used in the acid process for the manufacture of steel, the sulphur content of the coke should not exceed 0.7 per cent., and the phosphorus 0.01 per cent. It will be necessary, therefore, to determine experimentally whether the coal may be cleaned to such an extent that the coke produced will comply with such requirements.

Where the coal is to be wet-cleaned before carbonisation, moisture is of no importance, except in so far as it incurs extra handling and storage costs.

Intermediate between the laboratory and plant-tests is the

## Manufacture of Town's Gas

so-called bag-test, in which from 10 to 15 lb. (or sometimes more) of the coal is put into a bag surrounded by a cage of iron wire and introduced into the middle of an oven charge. When the oven is discharged, the cage of coke can be separated from the remainder of the charge and tested. In this way an opinion can be formed whether it is worth while to order sufficient of the coal to provide full charges for a number of ovens.

### SELECTION FOR MANUFACTURE OF TOWN'S GAS

The business of a gas company being primarily to sell gas of a constant, declared calorific value, the yield of gaseous therms per ton (as determined by the high temperature assay already described) forms the best basis for comparison of different coals, that coal being the best which gives the greatest yield of gaseous therms consistent with the declared calorific value being maintained, and with the coke being of saleable quality.

The best English gas coals generally yield between 30 and 40 per cent. of volatiles, calculated on the dry ashless coal, at 900° C.

The coke should be sufficiently strong to stand handling and transport without undue production of smalls, but, generally speaking, it should not be as compact and non-porous as metallurgical coke.

Sulphur is undesirable, since sulphur compounds must be removed before the gas is distributed, and high sulphur in the coke will give rise to unpleasant fumes which will hinder its sale for domestic purposes. Other things being equal, therefore, the lower the sulphur the better.

The moisture and ash in the coal should be as low as possible; the former because it entails loss of heat when evaporated in the retorts, and increases the quantity of ammonia liquor, and the latter is concentrated in the coke.

The calorific value of his raw material is not usually considered by the gas manager, who concentrates his attention on the yields and qualities of the products, particularly on the gas.

Some large gas concerns, amongst which the Birmingham Corporation Gas Department may be cited as an example, have a full-scale test plant which in itself constitutes a small gasworks. At the Nechells gasworks are four beds of full-sized horizontal through retorts capable of handling 31 tons of coal a day, an intermittent vertical retort bench, and a bench of continuous vertical retorts with through-put capacities respectively of 14 and 20 tons of coal a day, together with the necessary auxiliary plant. In this plant, which is larger than many small provincial gasworks, tests may be carried out which enable accurate determinations to be made as to the best operating conditions and as to the yields of gas and residuals.



## Fuel Testing

### SELECTION FOR LOW TEMPERATURE CARBONISATION

The coal should be low in moisture and ash, on carbonisation at the working temperature of the plant in which it is to be used (500° to 600° C.) it should give a non-swollen coke of sufficient strength to stand handling and transport. The probable yields of products and the general nature of the coke may be forecasted by means of the low temperature assay.

### SELECTION FOR PULVERISED FUEL FIRING

Although it has been claimed that almost any kind of coal, however low grade, can be successfully burned in the pulverised condition, and while the claim has been substantiated, there are certain desirable properties which should influence the selection of the coal.

The moisture should be as low as possible, since the power required for grinding and the capacity of the mill decreases with increase of moisture.

High volatiles are advantageous; for the same release of heat per unit of combustion volume, the loss of unburned carbon is lower with high than with low volatiles, and in addition ease and stability of ignition are favoured by high volatiles.

A high caking index may be deleterious, since strongly caking coals tend to give aggregates of adhering particles of coke in the furnace whereby the effect of fine grinding is counteracted and loss of unburned carbon is increased. Swelling, if unaccompanied by caking, tends to increase the loss of carbon, since the increased volume of the particles favours their being carried right across the furnace in suspension and out of the zone of combustion, with the waste gases.

High ash is undesirable; the higher the ash, the lower the flame-velocity, hence ease of ignition and stability of the flame are reduced. The cost of grinding a high-ash coal is greater than with the same coal which has been cleaned, since not only is more power required to grind each unit of combustible, but the wear and tear on the mill is increased.

### SELECTION FOR DOMESTIC PURPOSES

(a) *Open Fires and Cooking Ranges.*—High purity (low moisture and ash) and ease of ignition, together with absence of marked caking propensity, are required. Rather high volatiles (say over 35 per cent.) are necessary. The practice of marketing run-of-mine coal for domestic purposes is to be condemned; the larger pieces must be broken before being used, and since most "house coals"

## Purchase of Coal

are bright, much small and dust is produced during the breaking. This dust, added to the considerable quantity which is always present, and which is made when the coal is shot into the coal-cellar, is a source of embarrassment to the user, and although some of it may be employed to bank the fires when it is desired to secure low rates of combustion, there is almost always a superfluity which is difficult to dispose of.

(b) *Central Heating and Slow Combustion Stoves.*—Anthracite is most satisfactory ; the size is important, since the area of the grate on which the fuel is burned is generally restricted. The particular size chosen should be from pea to nut, depending on the area of grate and the width of the spaces between the firebars. Sized gas- or furnace-cokes are often used to heat domestic boilers but often give trouble, due to formation of clinker.

The public should be warned against a common practice of coal merchants of showing “ samples ” of domestic fuel neatly arranged in scuttles in their windows. The “ samples ” generally consist of carefully selected pieces, without their accompanying proportion of dust and, although they may be indicative of the *kind* of coal to be supplied, they are in no sense representative, and are therefore misleading. Purchasers should therefore demand that the coal supplied should be *as sample*, not only in respect of kind of coal, but also as to size.

A summary of the tests to be applied and the information derivable from those tests is given in Table XXV, which is intended to provide a general guide to the selection of coal for industrial and domestic purposes.

### THE PURCHASE OF COAL UNDER CONTRACT

Large consumers of coal are concerned that their supplies shall be adequate to their requirements in respect of both quality and quantity, and they are desirous also that such supplies shall be of uniform quality so that the operating conditions of their plants may follow a definite routine, particularly where the labour available is not of the highest grade. It is desirable, therefore, that a contract should be entered into for the supply of the requisite quantity of coal at a fixed price for a considerable period in advance, say twelve months, such coal to be of a quality suitable for the plant in which it is to be used, and also that the contract should embody safeguards to ensure that the standard shall be maintained.

A large power station consuming about a quarter of a million tons of coal per annum under water tube boilers adopted the following procedure, which may serve as a model on which, with suitable local modification, other contracts might be based :

# Fuel Testing

TABLE

THE SELECTION OF COAL

Purpose for which the Coal is to be Used.	Proximate Analysis.			Character of the Carbonised Residue and the Caking Propensity of the Coal.	Character of the Ash.	
	Moisture.	Volatiles.	Ash.			
<i>Steam Raising.</i> Small internally fired boilers.	Low moisture is always desirable; should additional moisture be required, as, for example, in burning slack coal under boilers, the extra water may be added as required, and under careful control.	10 to 20 % of <i>hard</i> coal of higher volatiles.	A low ash is to be burned on chain-grate stokers, a minimum of 7 % is generally required, otherwise the grate-links burn out rapidly.	Non-caking.	The ash should generally show a high softening temperature, except in coals used for the manufacture of metallurgical coke where a low softening temperature is advantageous. For coals which are to be burned pulverised, the softening temperature of the ash is not of great importance.	
Sprinkling stokers.				Non-caking.		
Chain grates.				Depends on the design of the plant.		Should be weakly caking.
Coking stokers.						
Underfeed stokers.						
<i>Carbonisation.</i> Gas manufacture.				32-38 %.		Medium caking.
Coke manufacture.				20-30 %.		Strongly caking. A hard, non-porous residue is required.
Low temperature.				Over 32 %.		Should be firm and strong but <i>not</i> swollen.
<i>Domestic Heating.</i> Open fires and cooking ranges.				High. 35-40 %.		Non-caking, or at most weakly caking.
Central heating and slow-combustion stoves.				Low. Under 8 %.		
<i>Gas-Producers.</i>	High. 35-40 %.	Non-caking, or very weakly caking.				
<i>Pulverised Coal.</i>		Preferably high. May be as low as about 7 %.	Non-caking or weakly caking preferable. A coal which swells is better avoided.			

XXV

FOR INDUSTRIAL PURPOSES

Calorific Value.	Carbonisation Assay.	Ultimate Analysis.				Other Determinations.	
		C	H	N	S	Phosphorus.	Arsenic.
<p>High calorific value is always desirable, since the potential heat in the coal is a measure of its value. With a given coal, the calorific value is roughly proportional to the content of combustible. High calorific value is therefore indicative of high purity.</p>	<p>Little useful information.</p> <p>The test is designed primarily for the examination of coals used for carbonisation. Enables the yields of gas, coke, tar and ammonia to be predicted. Also the type of carbonised residue may be judged.</p> <p>A useful test. Low temperature carbonisation takes place in the upper part of the producer, the gas going to enrich the producer-gas. A low yield of tar is advantageous if the gas-cleaning plant is of low capacity.</p> <p>No useful information.</p>	<p>Seldom determined except on samples taken on special tests of plant.</p>				<p>Should be regularly determined.</p>	
		<p>Low sulphur is always desirable. The emission of oxides of sulphur when coal is burned may give rise to serious atmospheric pollution, causing damage to property and to animal and vegetable life. Part of the sulphur in blast-furnace coke enters the iron; in coke for smelting hematite ores, the sulphur should not exceed 0.7%.</p>				<p>Of little importance except in the manufacture of metallurgical coke. If coke is to be used in the smelting of hematite ores, the phosphorus in the coke should not exceed 0.007%.</p>	
						<p>A very minor constituent which may, however, be important where the gases from the combustion of the coal come into contact with food-stuffs, for example, in the drying of hops and in malting kilns.</p>	

## Fuel Testing

In the early autumn, notices were published in the local press to the effect that tenders for the supply of boiler slack for the ensuing year would shortly be called for, and contractors wishing to supply coal were invited to notify the authorities concerned.

On receipt of information that a particular contractor proposed to tender, the chief of the testing department of the power station paid a visit to the wharf where the coal offered was stored, inspected the pile and took a careful sample. Samples thus taken were tested in the laboratory for moisture, proximate analysis, sulphur and calorific value, and if the coal seemed likely to be suitable, the contractor was asked to supply a consignment of about 250 tons from *the heap which had already been sampled*, this large sample to be paid for at the price quoted in the tender.

The 250 ton lot was sampled, a screening test and the same tests as on the small sample already examined were carried out; the coal was burnt under one boiler fitted with a water meter, serving to fire the boiler for between three and four days. The water meter was read when the sample coal began to be burned and again when the supply ran out, by which means a good working knowledge of the likely evaporation which would be given by the coal was secured. During the period when the sample coal was being used, and after the correct conditions for its combustion had been established, one or two twelve-hour boiler trials were carried out, observations being made in the usual manner of the coal fired, water pumped to the boiler, steam output and quality, riddlings under the grate, ashes removed, combustible therein, and analysis and temperature of the waste gases.

As a result of the long test and the shorter boiler trials, it was possible to assess with considerable accuracy the value of the coal, and to determine whether any difficulties such as clinker formation were likely to arise if it were used for prolonged periods, and also the relative values of the different coals submitted. When the tenders were opened and the prices asked for the coals were disclosed, the costs per 1000 lb. of steam could be calculated.

During the term of the contract, all consignments of coal were sampled while being unloaded and tested in the laboratory, and the results of the tests were compared with those previously obtained from the 250 ton lot, a sliding scale of prices being provided for in the contract for variations from the agreed standard of quality, which was that of the 250 ton sample tried under the test boiler.

The bonus and penalty clauses were carefully designed to discourage any tendency on the part of the contractor to depart from the standard which he had set up for himself.

It should be mentioned that the methods to be adopted in the sampling and analysis of the coal were clearly and precisely set out

## Purchase of Coal

in the printed form of contract so that there should be no excuse for any dispute as to discordant results which might arise from failure to standardise these important points.

Since the moisture might vary from time to time from the standard set up in the contract owing to climatic conditions, if the moisture exceeded the standard percentage, the weight of coal to be paid for was decreased below the quantity actually weighed by a percentage equal to the increase in percentage of moisture, and *vice versa*. For example, if the standard moisture of the coal were 6.5 per cent., and 3000 tons were weighed into the bunkers at 7.5 per cent. moisture, 1 per cent. (or 30 tons) was deducted from the 3000 and actually 2970 tons of coal at 6.5 per cent. of moisture were paid for.

If the calorific value exceeded the standard, the price per ton was increased in like ratio, but if the calorific value fell below the standard, the price per ton was decreased by 1.75 per cent. for each 1 per cent. such decrease. This was to discourage any desire on the part of the supplier to vary the quality of the coal. Moreover, the right was reserved to reject all or any part of a consignment whose calorific value fell more than 7 per cent. below the standard.

The percentage of dust coal was taken into consideration, dust being defined as that portion passing an 8-mesh sieve, and if the dust percentage increased above the standard, the weight of coal to be paid for was decreased by a percentage equal to one quarter of the increase in percentage of dust, and *vice versa*. Hence, if the standard percentage of dust happened to be 60 per cent., and a consignment of 3000 tons of coal contained 50 per cent. of dust, an addition to the weight to be paid for was made of  $2\frac{1}{2}$  per cent., or 75 tons.

An increase of ash over the standard of 5 per cent. was allowed without direct penalty (the calorific value clause would of course operate, as the increase in ash would be accompanied by a decrease in calorific value). After that, for each per cent. above, a deduction from the price of approximately 4d. a ton was exacted.\*

It had been found that the volatile matter in the coal had considerable influence in the steaming capacity of the boilers, and it was therefore agreed that, in the event of the volatile matter in the coal falling below the standard by 5 per cent., no bonus should be paid even if due by reason of enhanced calorific value or diminished dust content, and for every per cent. fall in volatiles below the 5 per cent. mentioned above, a deduction in price of approximately 4d. a ton was made.

The laboratory sample from each consignment of coal was

\* The contract price of the coal varied from 24s. to 36s. per ton.

## Fuel Testing

divided into two parts, one of which was at the disposal of the contractor, and the other was retained in the laboratory until the particular consignment which it represented had been paid for.

While the exact details outlined above may require to be modified to meet particular cases, the summary will be useful as an indication of the points which may require attention in arranging a contract for the supply of coal on a sampling basis.

### THE PREPARATION OF TECHNICAL REPORTS

The preparation of reports is a duty which often falls to the chemist, and is one which is so often carried out in slipshod fashion that some remarks on the subject are not out of place.

The Author is aware that, in venturing to set up a standard for the composition of reports, he lays himself open to the danger of being judged by his own standard, and, doubtless, will often be found wanting. To any critic who may adopt this line of attack, the Author would reply in the words of Dr. Johnson, "Sir, you are grossly ignorant of human nature, as not to know that a man may be very sincere in good principles, without having good practice."

Setting aside the usual routine reports which are generally tabulated, it is often necessary to report on new ideas, on proposed new methods of work and on technical problems in general.

The first thing is to ascertain the exact subject-matter of the report, and the purpose for which it is to be written; in other words, to define the ground to be covered, in order that valuable time may not be wasted in dealing with unessential matter.

The next stage is to determine the facts; facts may be first-, or second-hand, the former including all information collected by direct observation and experiment by the person responsible for the report, while the latter include information received from others or derived from the literature. Second-hand facts should always be received with caution and, wherever possible, corroborated by direct observation and experiment. Considerable tact and caution are required in collecting and checking second-hand facts, since offence may be taken by those furnishing information if they suspect that what they have to tell is not accepted without further enquiry. As a result, a hostile atmosphere is created, and sources of information may become unusually unreliable or may altogether dry up.

Few people are competent observers, and still fewer are capable of both accurately observing and reporting what they see. A substratum of fact is liable to be so overlain by a theory subconsciously put forward to explain what is observed that information received at second-hand may be so distorted as to be utterly useless, if not misleading.

## Preparation of Technical Reports

Facts which appear at first sight to be irrelevant may be found to provide the clue to a perplexing problem, and should be noted with as much care as those which obviously bear on the case ; particularly in the early stages of an enquiry it is difficult or impossible to say whether a fact is relevant or not.

Having ascertained the facts, it is necessary to review them, and to consider their bearing on the matter in hand, a hypothesis being formed to bind them into a coherent whole, always remembering that the hypothesis should be as simple as possible and consistent with *all* the facts. Should a single fact be inconsistent with the explanatory hypothesis, it will be necessary to review the whole and to modify the explanation until it is conformable with all the facts. Considerable strength of mind is required to discard a carefully thought out theory which has involved much thought and labour, but if necessary the theory must be ruthlessly dismissed and another substituted.

### Writing the Report

Although adherence to a stereotyped form of report is neither necessary nor desirable, systematic arrangement is essential to ensure that no material point is omitted, and to assist the recipient to a rapid and clear appreciation of the contents. The following outline is convenient as a basis, and may be modified to suit particular circumstances :

Every report should be given a serial number for ease of reference, and it may be advisable to separate the reports into several series, according to subject-matter or otherwise, each member of each series being numbered consecutively.

A report covering several pages should have a separate title-page carrying the serial number, the title (in block letters), the name or names of those responsible for its preparation, the date of issue, and the names or designations of all the persons to whom copies are sent.

The body of the report is conveniently divided into several sections, each section being titled in block letters.

**OBJECTS.**—A clear statement of the problem under discussion should be set out.

**CONCLUSIONS.**—The findings of the enquiry should be clearly and concisely stated, the evidence on which they are based being reserved to a later section.

**RECOMMENDATIONS.**—Any suggestions as to action which should be taken as a result of the conclusions should be given.

**EXPERIMENTAL.**—A concise outline of experimental work carried out in connection with the report should be given. It is unnecessary to describe standard methods in detail ; these may be referred to, provided the references will be understood by the recipients of the



## Fuel Testing

report. Special apparatus or methods devised for the investigation should, however, be described and illustrated, if necessary, by sketches. All evidence collected should be summarised and set out under this heading. Numerical experimental results are best tabulated in an appendix, except in so far as it may be desirable to give one or more examples to illustrate them.

**OBSERVATIONS OR INFERENCES.**—This section should comprise a clear exposition of the manner in which the different lines of evidence have been synthesised to give the conclusions already stated, as many lines of thought as possible being given.

**APPENDIX (or Appendices).**—Tabulated figures derived from experiment or collected in other ways should be given here, the sources being clearly stated. It should here be remarked that acknowledgment for help and information received should be generous ; this is not only on the grounds of scientific honesty, but a better atmosphere is created if subordinates and assistants feel that due credit will be given for what they have done.

The report should be read by the Author, and preferably also by some other person not connected with its preparation to ensure that the meaning is clearly conveyed, and it should finally be signed by the person or persons responsible.

In the composition of such a report, the following general rules should be carefully attended to :

(a) Brevity and clarity of expression should be aimed at. The report will be read by a busy man, therefore unessential matter should be excluded. While a detailed treatise may be of great interest, a clear and concise statement will command more respectful attention.

(b) Unnecessary scientific and technical terms should be avoided, since they may not be intelligible to the reader ; where technicalities are necessary, their meaning should be defined.

(c) Fact and fiction (i.e. hypothesis) should be carefully separated. If a statement is based on observation or experiment, this should be made clear : any hypothetical matter should be clearly indicated.

(d) Personal statements should be avoided. The constant repetition of " I, I, I " is annoying. It is therefore preferable to write impersonally.

(e) If a statement is made at first-hand, this should be made clear : if information has been derived at second-hand, the source should always be given.

(f) Due regard should be paid to the use of correct and idiomatic English.

(g) Since the object of speech (or writing) is to convey thought, no word should be used unless its meaning conveys the idea which

## Preparation of Technical Reports

it is desired to express ; “ learned ” bodies (who should know better) are in the habit of holding conferences on various subjects, which they describe as “ symposia,” in other words, “ merry or convivial drinking parties.” Those who have attended these conferences will appreciate how misleading is the name applied to them.

(h) Superlatives and adverbs should be sparingly used ; their unnecessary employment weakens the effect.

Perusal of a report should enable the reader to form such a clear and comprehensive idea of what was in the mind of the writer that further verbal explanation is unnecessary ; a request for amplification is an indication that the report is defective. Obscurity may arise from one of two causes, either the writer is unwilling to take the trouble to express himself intelligibly, or else his ideas are not clear to himself. The origin of obscurity of expression is laziness, which often manifests itself in an attitude of superiority to what is stigmatised as “ fine writing ” ; frequently also, inability to express himself in writing is given as an excuse. The fact is, that precision in thinking and precision in writing are difficult arts to acquire ; much practice is necessary and rather than take the trouble to acquire the habit, chemists and others prefer to sign their names to reports which would be a disgrace to a fourth-form schoolboy.

From the cultural point of view, the accuracy in the use of words is amply repaid in that the writer is compelled to give closer definition to his thoughts to express them to the best advantage, while slovenliness in expression often leads to carelessness in other directions. From the material point of view, a badly written report may conceal otherwise good work, leading the management to suspect the writer of incompetence. It is not uncommon to meet competent and hard-working technical men who have missed promotion simply because they would not or (less probably) could not express themselves in writing.

It is an unfortunate but well-known fact that students of science and technology who have perforce studied and passed examinations in English, from that time forward cease to devote any time or energy to the study of their own language, the consequence being that instead of improving, their English deteriorates. Some of the blame must be laid on the teachers at the Universities and Technical Schools for their failure to insist not only on accuracy in experimental work, but also on the necessity for equal accuracy in the preparation of descriptions of that work. More time should also be given to the writing of reports and essays, while greater credit might well be given for literary style and accuracy of expression in assigning marks in examinations. Until students are forced to pay greater attention to the presentation of their work, the present unsatisfactory state of affairs is likely to continue, for it is only

## **Fuel Testing**

the exceptional student who, faced with a curriculum which is already heavily loaded, will go out of his way to improve himself in directions which, so far as he can see, his teachers do not regard as essential.

### **BIBLIOGRAPHY**

The following well-thumbed volumes should be constantly at hand :

H. W. and F. G. Fowler, "The King's English," 1930.

H. W. Fowler, "A Dictionary of Modern English Usage," 1937.

P. M. Roget, "Thesaurus of English Words and Phrases."

They should be in constant use, and referred to whenever there is any doubt about the best mode of expression.

CHAPTER XV

COMBUSTION CALCULATIONS

THE calculation of heat losses and heat balances is such an important duty of the Fuel Technologist and the Chemical Engineer, and is so often performed in an unnecessarily laborious manner (which introduces possibilities of error) that it has been considered desirable to show how easy combustion calculations really are, and how they may be performed rapidly and with the least effort on the part of the computer.

CALCULATION OF THE AIR REQUIRED FOR COMBUSTION. SOLID AND LIQUID FUELS

Since the first step in the solution of nearly all combustion problems is to determine the quantity of air required to burn unit weight of the fuel, the ability to make this calculation accurately and rapidly is of fundamental importance. In dealing with solid and liquid fuels, the simplest method is to calculate the number of molecules of air required to burn 100 weight-units of the fuel, in other words, to employ undefined units from which it is easy to convert into defined units of weight or volume. To do this, the percentage composition is re-calculated, the solid elements being calculated as "atoms" (by dividing the percentages by their respective atomic weights) and the gaseous elements as "molecules" by dividing by the appropriate molecular weights. Thus, for example, a coal having the composition :

	Per Cent. by Weight.	Divide by	" Atoms."	" Molecules."	" Molecules " of Oxygen Required.	
Moisture	5.0	18	—	0.28	—	
Carbon .	74.1	12	6.17	—	6.17	
Hydrogen	5.1	2	—	2.55	1.28	
Nitrogen	1.35	28	—	0.05	—	
Sulphur	0.95	32	0.03	—	0.03	
Oxygen .	9.5	32	—	0.30	-0.30	
Ash .	4.0	Takes no part in the combustion				—

## Fuel Testing

The number of "molecules" of oxygen required for complete combustion of each element can then be written down immediately, remembering that each atom of carbon and sulphur requires one molecule, and each molecule of hydrogen, half a molecule of oxygen. The number of "molecules" of oxygen in the 100 parts of the fuel must be deducted from the quantity required by the combustible elements. 100 parts of the coal require 7.18 "molecules" of oxygen for complete combustion, and since 100 molecules of air contain 20.9 molecules of oxygen, the dry air required to burn completely 100 weight-units of coal will be  $\frac{7.18}{0.209}$  or 34.36 "molecules."

If the basis chosen were pounds, then 34.36 lb.-mols. would be required per 100 lb. of coal; similarly, had the basis been kilos, 34.36 kilo.-mols. would be required.

Since the molecular weight of dry air is 28.97, the weight of dry air required per 100 lb. (or kilos) of coal would be

$$34.36 \times 28.97 = 995.3 \text{ lb. (or kilos).} \checkmark$$

The volume of air may readily be calculated, remembering that the pound-molecular volume at N.T.P. is 359 cu. ft. and that the kilogram-molecular volume is 22.4 cu. metres. Hence the volume of dry air required to burn

$$\begin{aligned} 100 \text{ lb. coal} &= 34.36 \times 359 = 12,340 \text{ cu. ft.}, \\ 100 \text{ kilos ,,} &= 34.36 \times 22.4 = 769.7 \text{ cu. m.} \end{aligned}$$

The lb.-molecular volume at 60° F. and 30 in. Hg (saturated) is 385 cu. ft., or at 60° F. and 30 in. Hg. (dry) is 379.2 cu. ft. (or, with sufficient accuracy, 380 cu. ft.).

The composition of the dry products of combustion (i.e. as determined by gas analysis) may be written down by inspection of the above table, and the effect of varying percentages of excess air may be studied as in Table XXVI.

From these results, two useful charts (Figs. 57 and 58) may be plotted. In Fig. 57 the relation between the percentage of CO<sub>2</sub> in the gases and the percentage of excess air is shown, while in Fig. 58, the percentage of CO<sub>2</sub> in the gases is plotted against the percentage of oxygen. This chart is useful in that it enables incomplete combustion to be detected at once. If combustion is incomplete, the percentage of CO<sub>2</sub> in the gases will be less than that corresponding with the oxygen found. For example, if the gas analysis showed CO<sub>2</sub> = 12.5 and O<sub>2</sub> = 6 per cent., incomplete combustion would be indicated, since the CO<sub>2</sub> corresponding to 6 per cent. oxygen (if combustion were complete) would be 13.27 per cent.

## Combustion Calculations

### TABLE XXVI

COMPOSITION OF DRY PRODUCTS FROM THE COMBUSTION OF A COAL WITH DIFFERENT PERCENTAGES OF EXCESS AIR

	Excess Air, Per Cent.							
	Nil.		50		100		150	
	Mols.	Per Cent.	Mols.	Per Cent.	Mols.	Per Cent.	Mols.	Per Cent.
CO <sub>2</sub> .	6.17	} 18.55	6.17	} 12.25	6.17	} 9.15	6.17	} 7.30
SO <sub>2</sub> .	0.03		0.03		0.03		0.03	
O <sub>2</sub> .	—	—	3.59	7.09	7.18	10.59	10.77	12.68
N <sub>2</sub> .	27.23	81.45	40.82	80.66	54.41	80.26	68.00	80.02

*Note.*—In the analysis of the gases, the CO<sub>2</sub> and SO<sub>2</sub> are determined together and returned as “CO<sub>2</sub>”: the combined percentage is therefore given in the table. Also, the nitrogen is made up of 0.05 molecules derived from the coal, *plus* the very much larger quantity from the air.

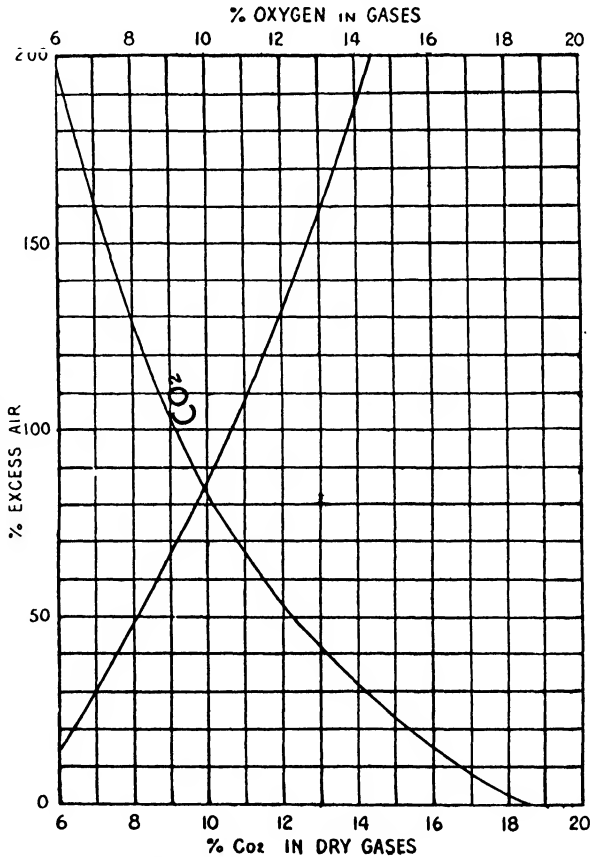

FIG. 57.—The Relation between Carbon Dioxide, Oxygen and Excess Air in the Combustion of Coal.

## Fuel Testing

In practice, the problem is usually, given the composition of the fuel and of the dry gases, to determine the percentage of excess air which has been used and the quantity of gases passing through the system per unit weight of the fuel.

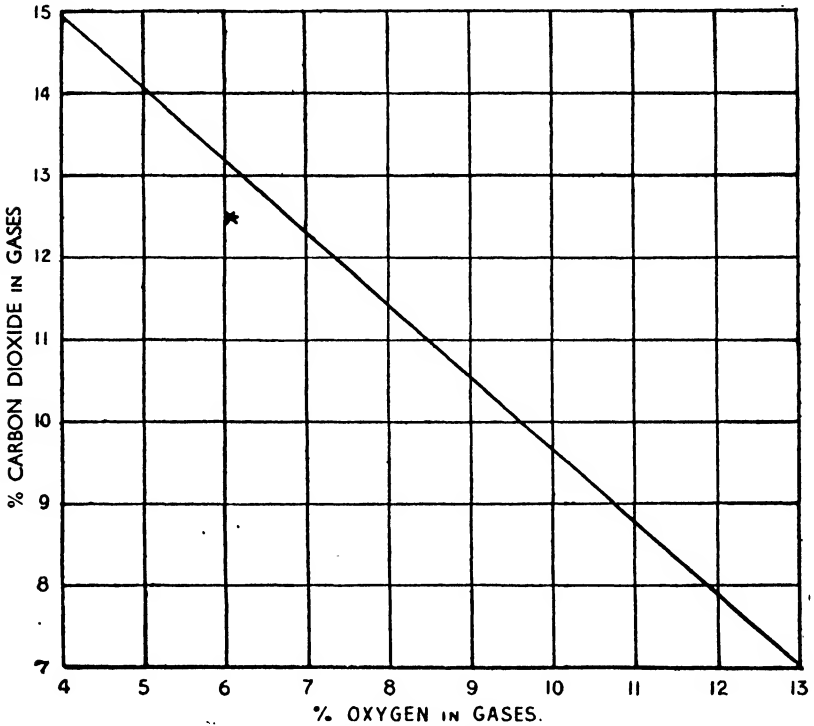

FIG. 58.—The Relation between the Carbon Dioxide and Oxygen in the Dry Gases from the Combustion of a Coal.

### CALCULATION OF THE WASTE-GAS/FUEL RATIO AND THE EXCESS AIR

Composition of dry flue gases :  $\text{CO}_2 = 8.25$  ;  $\text{O}_2 = 11.35$  ; and  $\text{N}_2 = 80.4$  per cent.

Inspection of Fig. 58 shows that combustion was complete, that is, all the carbon in the coal appears in the waste gases. Since 100 mols. dry gases contain 8.25 mols.  $\text{CO}_2$ , and 100 lb. coal contain 6.2 lb.-atoms. of carbon *plus* sulphur, from a carbon balance, 100 lb. coal give  $\frac{100 \times 6.20}{8.25}$  or 75.15 lb.-mols. dry gases, containing

$$\text{CO}_2 = 8.25 \times 0.7515 = 6.20 \text{ lb.-mols.}$$

$$\text{O}_2 = 11.35 \times 0.7515 = 8.53 \quad ,,$$

$$\text{N}_2 = 80.4 \times 0.7515 = 60.42 \quad ,,$$

## Problem of Incomplete Combustion

to which must be added the steam from (i) the evaporation of moisture in the coal, namely 0.28 lb.-mols., and (ii) the combustion of the hydrogen in the coal, 2.55 mols. Hence the total gases per 100 lb. of coal are :

CO <sub>2</sub> (and SO <sub>2</sub> )	= 6.20 lb.-mols.	= 272.8 lb.
O <sub>2</sub>	= 8.53 ,,	= 273.0 ,,
N <sub>2</sub>	= 60.31 ,,	= 1688.7 ,,
Steam	= 2.83 ,,	= 60.9 ,,
Total	= 77.87 ,,	= 2295.4 ,,

The air used per 100 lb. coal, and therefore the excess air, may be calculated from a nitrogen balance, remembering that the nitrogen in the gases is derived mainly from that in the air, but to a small extent from the nitrogen in the coal. If  $x$  = the number of lb.-mols. of air used per 100 lb. coal, the nitrogen in the gases per 100 lb. coal =  $0.791x + 0.05 = 60.31$  lb.-mols., whence  $x = 76.17$  lb.-mols. per 100 lb. coal. But 100 lb. coal required 34.36 lb.-mols. air for complete combustion (p. 260). Hence the excess air = 41.81 lb.-mols. or 121.8 per cent.

### THE PROBLEM OF INCOMPLETE COMBUSTION

In practice, complete combustion rarely occurs. When burning a solid fuel, not only is there a certain amount of unburned carbon discharged with the solid refuse, which may be determined by taking a representative sample of the ashes and analysing for carbon, but a certain amount of carbon escapes as soot, giving rise to a loss of combustible which is almost impossible to determine directly. With liquid fuels, although there is little or no solid refuse, there is generally quite an appreciable loss of carbon as soot. Provided that the compositions of the fuel and the waste gases are accurately known, quite a good estimate of the quantity of carbon escaping unburned may be made.

If the waste gases from the coal already considered contained CO<sub>2</sub> = 12.50, CO = 0.15, O<sub>2</sub> = 6.05, and N<sub>2</sub> = 81.30 per cent., inspection of Fig. 58 shows that combustion cannot have been complete. How much carbon has escaped unburned may be calculated as follows :

The free oxygen in the gases, less that required to burn the CO to CO<sub>2</sub> (or 0.08 per cent.) represents air in excess of that required for complete combustion, and the composition of the waste gases may be rewritten :



## Fuel Testing

CO <sub>2</sub>	= 12.50	per cent.	
CO	= 0.15	„	
O <sub>2</sub>	= 0.08	„	required to burn the CO.
Excess air	= 28.57	„	$= \frac{6.05 - 0.08}{0.209}$ .
Nitrogen	= 58.70	„	from the air actually used for combustion.

It has already been shown (p. 261) that when 100 lb. of the coal are completely burned without excess of air, for every 27.23 lb.-mol. of nitrogen in the gases there must be 6.20 lb.-atoms of carbon.

In the gases above, 12.65 lb.-atoms carbon are associated with 58.70 lb.-mols. nitrogen from the air *actually burned*. Hence, per 27.23 lb.-mols. N<sub>2</sub>, there are  $\frac{27.23 \times 12.65}{58.70}$ , or 5.87 lb.-atoms of carbon. Thus, per 100 lb. coal, the amount of carbon which has escaped combustion must have been 6.20 - 5.87 = 0.33 lb.-atoms.

The undeveloped heat per 100 lb. of coal, due to the fact that this carbon escaped combustion, was therefore

$$0.33 \times 169,630^* = 55,980 \text{ B.Th.Us.}$$

Where combustion has been incomplete, this calculation should always precede the calculation of the quantity of waste gases and the heat lost therein, since until the unburned carbon has been estimated, the correct figure to be used for the carbon in the gases cannot be inserted in the carbon balance.

Since it is now known that, per 100 lb. of coal, 5.87 lb.-atoms of carbon appear in the waste gases, the quantity of waste gases per 100 lb. of coal can be determined.

$$\text{Dry gases per 100 lb. coal} = \frac{100 \times 5.87}{12.65} = 46.4 \text{ lb.-mols.}$$

These gases consist of :

CO <sub>2</sub>	= 46.4 × 0.125	= 5.80 lb.-mols.
CO	= 46.4 × 0.0015	= 0.07 „
O <sub>2</sub>	= 46.4 × 0.065	= 2.81 „
N <sub>2</sub>	= 46.4 × 0.813	= 37.73 „
		46.41 „
	<i>plus water vapour</i> (p. 263)	= 2.83 „
		Total = 49.24 „

\* Table XXVIII.

## Gaseous Fuels

The undeveloped heat arising from incomplete combustion of part of the carbon to CO =  $0.07 \times 121,720^* = 8520$  B.Th.U.s. Hence the total loss of heat due to incomplete combustion = 64,500 B.Th.U.s. per 100 lb. coal.

In making combustion calculations, it is unnecessary to use tables of greater accuracy than 4-figure logarithms; in fact, a 10-inch slide-rule will be sufficiently accurate. In returning percentages, as in preparing heat balances, the results should be given to the first place of decimals; the second decimal place, although it may give the results a fictitious appearance of greater accuracy, is unjustified, since the observations and data on which the calculations are based are always subject to uncertainty, few, if any of the observations being accurate to within 1 per cent.

The quantity of air used for combustion may now be calculated from a nitrogen balance. The gases from 100 lb. coal contain 37.73 lb.-mols. of nitrogen, of which 0.05 lb.-mols. are derived from the coal, whence the air used per 100 lb. coal

$$= \left\{ \frac{37.73 - 0.05}{0.791} \right\} = 47.6(4) \text{ lb.-mols.},$$

and the excess air

$$\left\{ \frac{47.64}{34.36} - 1 \right\} \times 100 = 38.6 \text{ per cent.}$$

### CALCULATION OF THE AIR REQUIRED FOR COMBUSTION. GASEOUS FUELS

Since the compositions of gaseous fuels are expressed as percentages by volume, combustion calculations are even simpler than for solid and liquid fuels; the preliminary step of dividing the percentages of solid elements by the atomic weights and gaseous elements by the molecular weights is unnecessary, since the appropriate numbers of atoms or molecules of the elements in each constituent are obvious from the formula.

For example, a coal-gas of the composition as shown in table at top of next page.

The composition of the *dry* products would be :

CO <sub>2</sub>	=	46.0 lb.-mols.,	or	11.24 per cent.
N <sub>2</sub> from gas	=	6.0	„	„
„ air	=	357.3	„	88.76 „

\* Table XXVIII.

## Fuel Testing

	Per Cent. or Lb.-Mols.	Lb.-Atoms Carbon.	Lb.-Mols. Hydrogen.	Lb.-Mols. Nitrogen.	Lb.-Mols. Oxygen Required.
CO <sub>2</sub> .	3.0	3.0	—	—	—
CO .	9.0	9.0	—	—	4.5
C <sub>n</sub> H <sub>m</sub> * .	3.0	9.0	9.0	—	13.5
CH <sub>4</sub> .	25.0	25.0	50.0	—	50.0
H <sub>2</sub> .	53.6	—	53.6	—	26.8
O <sub>2</sub> .	0.4	—	—	—	-0.4
N <sub>2</sub> .	6.0	—	—	6.0	—
	100.0	46.0	112.6	6.0	94.4

\* "Heavy" hydrocarbons whose precise composition is unknown are generally symbolised as C<sub>n</sub>H<sub>m</sub>, on the principle of "when in doubt, tell the truth," and for purposes of calculation are assumed to be C<sub>3</sub>H<sub>6</sub>.

100 lb.-mols. coal-gas require 94.4 lb.-mols. oxygen for complete combustion =  $\frac{94.4}{0.209} = 451.7$  lb.-mols. air.

As before, the effect of different percentages of excess air on the composition of the waste gases from the combustion of the above coal-gas may be calculated and tabulated as in Table XXVII.

TABLE XXVII

COMPOSITION OF THE DRY PRODUCTS. FROM THE COMBUSTION OF COAL-GAS WITH DIFFERENT PERCENTAGES OF EXCESS AIR

Excess Air Per Cent.	0		50		100		150	
	Mols.	Per Cent.	Mols.	Per Cent.	Mols.	Per Cent.	Mols.	Per Cent.
CO <sub>2</sub> .	46.0	11.24	46.0	7.24	46.0	5.34	46.0	4.23
O <sub>2</sub> .	—	—	47.2	7.43	94.4	10.96	141.6	13.03
N <sub>2</sub> .	363.3	88.76	541.96	85.33	720.6	83.70	899.25	82.74

Calculations as to the completeness of combustion, excess air, etc., are carried out as for solid and liquid fuels. Thus, if the composition of the waste gases from the above coal-gas was CO<sub>2</sub> = 6.0, CO = 0.1, O<sub>2</sub> = 9.5, and N<sub>2</sub> = 84.4 per cent., we have the following :

*Unburned Carbon*

The composition of the waste gases may be re-written :

$$\text{CO}_2 = 6.0$$

$$\text{CO} = 0.1$$

$$\text{O}_2 = 0.05, \text{ required to complete combustion of the CO.}$$

$$\text{Excess air} = 45.2$$

$$\text{N}_2 = 48.65, \text{ from air used in the combustion.}$$

TABLE XXVIII

## FUNDAMENTAL COMBUSTION EQUATIONS

Reaction.	Heat Change.	
	K.C.U.s. per Kgm.-Mol.	B.Th.U.s. per Lb.-Mol.
$\text{C} + \text{O}_2 \rightarrow \text{CO}_2$	+ 94,240	+ 169,632
$\text{C} + \frac{1}{2}\text{O}_2 \rightarrow \text{CO}$	+ 26,617	+ 47,911
$\text{CO}_2 + \text{C} \rightleftharpoons 2\text{CO}$	∓ 41,006	∓ 73,811
$\text{CO} + \frac{1}{2}\text{O}_2 \rightleftharpoons \text{CO}_2$	± 67,623	± 121,721
$\text{H}_2 + \frac{1}{2}\text{O}_2 \rightarrow \text{H}_2\text{O (liquid)}$	+ 68,313	+ 122,963
$\rightarrow \text{H}_2\text{O (vapour)}$	+ 57,809	+ 104,056
$\text{C} + \text{OH}_2 \rightarrow \text{CO} + \text{H}_2 \text{ (vapour)}$	- 31,192	- 56,146
$\text{C} + 2\text{OH}_2 \rightarrow \text{CO}_2 + 2\text{H}_2 \text{ (vapour)}$	- 21,378	- 38,480
$\text{CO} + \text{OH}_2 \rightleftharpoons \text{CO}_2 + \text{H}_2 \text{ (vapour)}$	± 9,814	± 17,666
$\text{CH}_4 + 2\text{O}_2 \rightarrow \text{CO}_2 + 2\text{H}_2\text{O (vapour)}$	+ 191,782	+ 354,208
$\rightarrow \text{CO}_2 + 2\text{H}_2\text{O (liquid)}$	+ 212,790	+ 383,022
$\text{C}_2\text{H}_4 + 3\text{O}_2 \rightarrow 2\text{CO}_2 + 2\text{H}_2\text{O (vapour)}$	+ 312,292	+ 562,126
$\rightarrow 2\text{CO}_2 + 2\text{H}_2\text{O (liquid)}$	+ 334,000	+ 601,200

The data relate to the reactions at 25° C. and under atmospheric pressure. The carbon is in the form of  $\beta$  graphite.

It has been shown (*supra*) that in the absence of excess air, for every 363.3 lb.-mols. nitrogen, there should be 46.0 lb.-atoms of carbon in the gases. Per 363.3 lb.-mols. nitrogen from the air *used*, the gases contain  $6.1 \times \frac{363.3}{48.65}$  or 45.56 lb.-atoms carbon. There is therefore a deficiency of 0.44 lb.-atoms carbon per 100 lb.-mols. coal-gas, or 0.96 per cent.

*Air Used for Combustion*

From a carbon balance, the ratio of waste gases to coal-gas burned must first be calculated.

## Fuel Testing

Per 100 mols. coal-gas, 45.56 atoms carbon appear in the waste gases, whence 100 mols. coal-gas produce  $100 \times \frac{45.56}{6.1} = 747$  mols. dry waste gases, or, including the 112.6 mols. steam derived from the hydrogen in the coal-gas, a total of 859.6 mols. of wet gases.

The air used is calculated from a nitrogen balance as follows : if  $x =$  the mols. air used per 100 mols. coal-gas, then

$$84.4 \times 747 = 6.0 - 0.791x,$$

whence  $x = 789.4$  mols., the percentage of excess air

$$= 100 \left\{ \frac{789.4}{451.7} - 1 \right\} = 74.7.$$

## CALCULATION OF THE HEAT LOST IN PRODUCTS OF COMBUSTION

To determine the loss of heat in the waste products from the combustion of any fuel it is necessary to know the quantity of the

TABLE XXIX

MOLAL SENSIBLE HEAT IN GASES. B.T.H.US. PER LB. MOL. ABOVE 0° C.

Based on Spectroscopic Data

“Technical Data on Fuel,” 1935, p. 118

°C.	O <sub>2</sub> .	N <sub>2</sub> .	Air.	CO.	H <sub>2</sub> .	CO <sub>2</sub> .	Steam.	CH <sub>4</sub> .	°F.
15	191	194	191	191	187	236	215	271	59
100	1,270	1,255	1,255	1,255	1,245	1,650	1,445	1,575	212
200	2,575	2,520	2,525	2,520	2,500	3,475	2,925	3,405	392
300	3,920	3,800	3,810	3,810	3,765	5,435	4,440	5,495	572
400	5,315	5,105	5,135	5,130	5,025	7,485	6,005	7,810	752
500	6,740	6,435	6,480	6,470	6,290	9,675	7,625	10,370	932
600	8,200	7,785	8,035	8,035	7,572	11,910	9,285	13,120	1,112
700	9,680	9,160	9,245	9,245	8,860	14,210	11,010	16,040	1,292
800	11,190	10,590	10,690	10,700	10,170	16,560	12,800	19,170	1,472
900	12,720	12,020	12,130	12,150	11,480	18,950	14,640	22,440	1,652
1,000	14,260	13,480	13,610	13,630	12,820	21,620	16,520	25,860	1,832
1,200	17,370	16,460	16,590	16,630	15,550	26,330	20,410		2,192
1,400	22,560	19,480	19,610	19,680	18,350	31,370	24,500		2,552
1,600	23,730	22,520	22,700	22,750	21,200	36,460	28,690		2,912
1,800	26,990	25,630	25,790	25,850	24,140	41,600	33,050		3,272
2,000	30,130	28,730	28,850	28,980	27,110	46,760	37,480		3,632
2,200	33,580	31,880	32,000	32,160	30,180	52,000	42,020		3,992
2,400	36,980	34,990	35,170	35,340	33,270	57,330	46,620		4,352
2,600	40,390	38,240	38,380	38,560	36,420	62,430	51,300		4,712
2,800	43,750	41,430	41,580	41,730	39,570	67,680	56,000		5,072
3,000	47,300	44,600	44,770	44,930	42,770	73,010	62,060		5,432

products, their temperature, and the mean specific heat at constant pressure of each of the components of the mixture. The mean specific heat of a gas varies with the temperature according to a law  $C_p = A + Bt + Dt^2$ , where  $t$  is the temperature and  $A$ ,  $B$  and  $D$  are constants proper to the gas under consideration, and  $C_p$  is the mean specific heat expressed as B.Th.U.s. per lb. or K.C.U.s. per kilo, depending on the system of units adopted. Since, however, the initial calculations were made in terms of lb.-mols. (or kilo.-mols.), it is more convenient to continue to work in these units, and much calculation can be saved (and at the same time, chances of error reduced) by employing a table and curves giving the total sensible heat per lb.-mol. above a selected datum which is always assumed to be the freezing-point of water, namely  $0^\circ$  C. or  $32^\circ$  F. Table XXIX gives the molal sensible heats of the more important gases, expressed as B.Th.U.s. per lb.-mol., calculated from the best available data.

Applying this to the waste gases from the coal already considered (pp. 259 and 264), if the gases have the composition  $\text{CO}_2 = 12.5$ ,  $\text{CO} = 0.15$ ,  $\text{O}_2 = 6.05$ , and  $\text{N}_2 = 81.30$  per cent., and are at  $572^\circ$  F., the temperature of the air supplied to the furnace being  $70^\circ$  F., the loss of heat may be calculated as follows :

It has been shown on page 264 that the gases per 100 lb. coal consisted of

$\text{CO}_2$	.	.	.	.	.	5.80 lb.-mols.
$\text{CO}$	.	.	.	.	.	0.07 ,,
$\text{O}_2$	.	.	.	.	.	2.81 ,,
$\text{N}_2$	.	.	.	.	.	37.73 ,,
Steam	.	.	.	.	.	2.83 ,,

It is necessary to calculate the heat removed by these gases above the temperature of the air supplied to the furnace, namely  $70^\circ$  F. With sufficient accuracy, the sensible heat contents at  $70^\circ$  F. may be taken to be proportional to the temperature, i.e., for example, for the  $\text{CO}_2$ , sensible heat at  $59^\circ$  F. = 236 B.Th.U.s. per lb.-mol.

	Mols.	Sensible $70^\circ$ F.	Heat at $572^\circ$ F.	Sensible Heat Above $70^\circ$ F.	Total Sensible B.Th.U.s.
$\text{CO}_2$	5.80	333	5435	5102	29,600
$\text{CO}$	0.07	269	3810	3541	248
$\text{O}_2$	2.81	269	3920	3651	10,260
$\text{N}_2$	37.73	273	3800	3527	133,000
Steam	2.83	303	4440	4137	11,700
				<b>Total .</b>	<b>184,808</b>

### Fuel Testing

Increment for 27° (since the datum level is 32° F.) = 236, or per degree 8.75 B.Th.U.s., hence at 70° F. the sensible heat will be  $236 + 11 \times 8.75$ , or 333.2 B.Th.U.s., which may be rounded off to 333. A table may now be constructed as above, and the total may be rounded off to 184,800 B.Th.U.s.

But, in addition, the latent heat of condensation in the steam must be taken into account. Since the latent heat of steam depends on the pressure, it is necessary to calculate the partial pressure of steam in the products.

If the total pressure of the gases is 30 in. Hg, then the partial pressure of the steam will be  $\frac{30 \times 2.83}{49.24} = 1.725$  in. Hg. The latent heat per lb.-mol. may be taken from Table XXX, or from a

TABLE XXX

PROPERTIES OF SATURATED STEAM AT LOW PRESSURES

Absolute Pressure. In. Hg.	Temperature.		Latent Heat.	
	°F.	°C.	B.Th.U.s. per Lb.	Lb.-Mol.
0.204	34.86	1.59	1068.2	19,220
1.02	79.5	26.4	1044.6	18,803
2.04	101.7	38.7	1032.9	18,637
4.09	126.1	52.3	1019.7	18,500
6.13	141.5	60.9	1011.3	18,203
8.17	153.0	67.3	1004.9	18,088
10.21	162.3	72.5	999.7	17,995
12.25	170.1	76.8	995.4	17,917
14.30	176.9	80.5	991.5	17,847
16.34	182.9	83.8	987.9	17,782
18.38	188.3	86.9	984.7	17,725
20.42	193.2	89.7	982.0	17,676
22.46	197.8	92.3	979.2	17,626
24.51	202.0	94.5	976.7	17,581
26.55	205.9	96.7	974.3	17,537
28.59	209.6	99.0	972.2	17,500
29.92	212.0	100.0	970.7	17,473

curve plotted from the data therein (Fig. 59). Latent heat of condensation at 1.725 in. Hg = 18,637 B.Th.U.s. per lb.-mol., and the heat in 2.83 lb.-mols. = 52,750 B.Th.U.s.

The heat losses may now be summarised and calculated to percentages on the heat of combustion of the coal, 13,200 B.Th.U.s. per lb. The basis is 100 lb. of coal as fired.

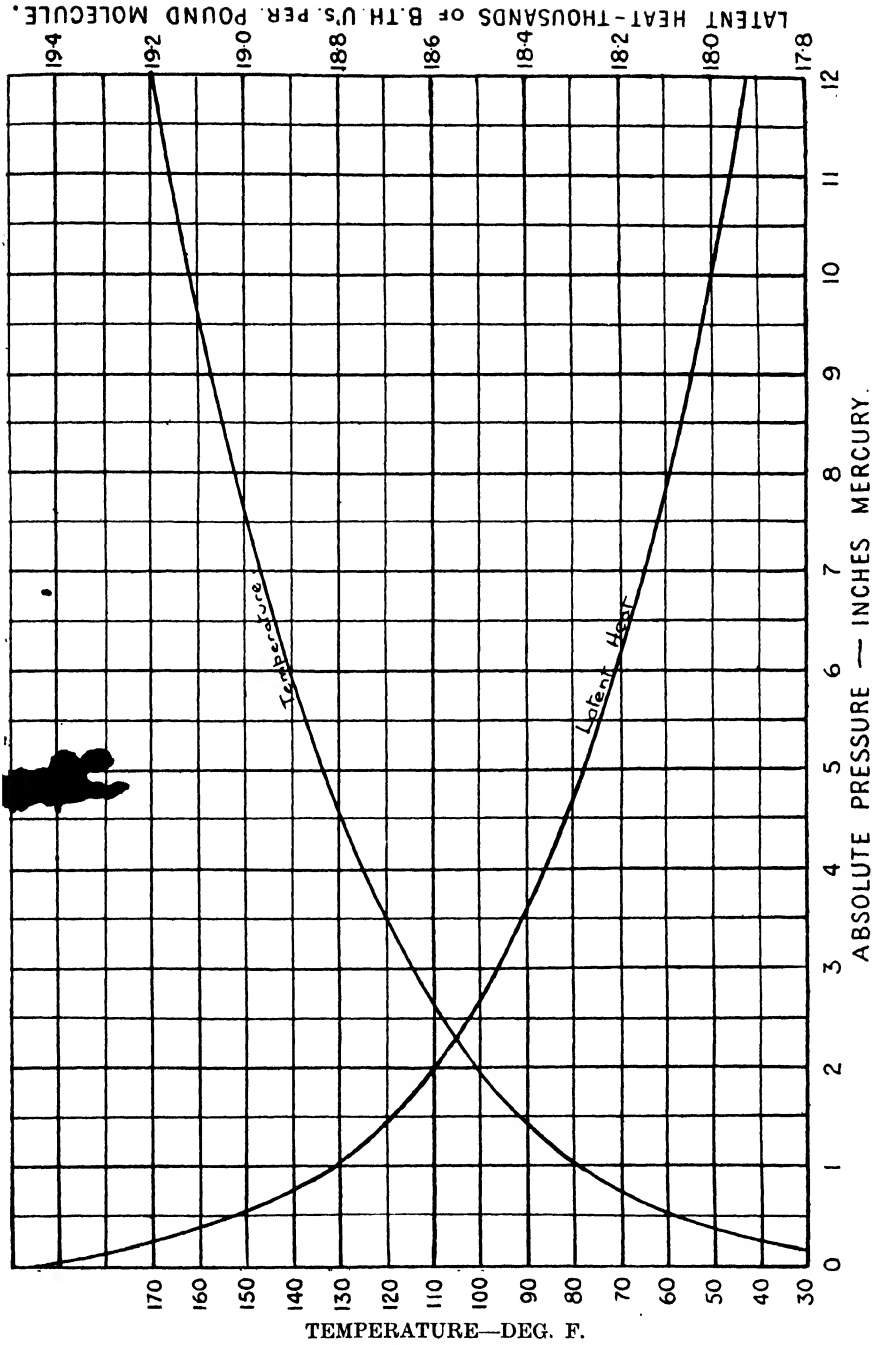

Fig. 59.—Properties of Saturated Steam at Low Pressures.



## Fuel Testing

Loss of Heat Due To	B.Th.U.s.	Per Cent.
Escape of unburned carbon . . .	55,980	4.3
In complete combustion of CO . .	8,520	0.6
Sensible heat in waste gases . . .	184,800	14.0
Latent heat of condensation of steam	52,750	4.0
<b>Total . . . . .</b>	<b>302,050</b>	<b>22.9</b>

In making these calculations, the effect of water vapour in the air used for combustion has been neglected. If the air used for combustion were 60 per cent. saturated, an extra 0.73 lb.-mols. of water vapour would be present in the gases (this is arrived at by the method outlined in the following section), and the loss of sensible heat due to this would be 3005 B.Th.U.s., making the total sensible heat in the waste gases 187,800 B.Th.U.s. or 14.2 per cent. of the heat of combustion of the coal. Since this extra water enters and leaves the system as vapour, the latent heat does not enter into the calculation.

### EFFECT OF MOISTURE CARRIED INTO THE SYSTEM BY GAS AND AIR

The following example is calculated from the composition of the coal-gas on page 266 and of the waste gases (p. 268):

Air used per 100 mols. gas . . . . . 789.4 mols.

If the gas is saturated with water vapour at 60° F. and the air 60 per cent. saturated at the same temperature, vapour pressure of water = 0.52 in. Hg.

Partial pressure of dry gas (assuming a total pressure of 30 in. Hg) = 29.48 in.

Mols. water per 100 mols. dry gas =  $\frac{0.52 \times 100}{29.48} = 1.77$ . Since the air is 60 per cent. saturated, 100 mols. dry air will carry  $0.6 \times 1.77 = 1.06$  mols. water vapour, and the water vapour in the air used to burn 100 mols. dry gas =  $7.894 \times 1.06 = 8.36$  mols.

Total water vapour entering the system per 100 lb.-mols. dry gas = 10.13 lb.-mols.

From a carbon balance, 100 lb.-mols. dry gas give  $\frac{45.56 \times 100}{6.1} = 747$  lb.-mols. dry products, and the total *wet* products will consist of

CO <sub>2</sub> = 747 × 0.060	= 44.82 lb.-mols.
CO = 747 × 0.001	= 0.75 "
O <sub>2</sub> = 747 × 0.095	= 70.95 "
N <sub>2</sub> = 747 × 0.844	= 630.47 "
Steam from combustion of hydrogen	= 112.6 "
Water vapour in air and gas	= 10.13 "

## Gas-Producer Calculations

The loss of sensible heat at (say) 1652° F. above 70° F. will be

	B.Th.U.s.
In CO <sub>2</sub> = (18,950 - 333) × 44.82 =	834,300
CO = (12,150 - 269) × 0.75 =	8,900
O <sub>2</sub> = (12,730 - 269) × 70.95 =	883,000
N <sub>2</sub> = (12,020 - 273) × 630.47 =	7,408,000
Steam = (14,650 - 303) × 112.6 =	1,616,000 from hydrogen.
Water vapour = (14,650 - 303) × 10.13 =	145,300 in gas and air.
Total =	10,895,500

Therefore the water vapour entering the system in the coal-gas and air will cause a loss of sensible heat of 145,300 B.Th.U.s. per 100 lb.-mols. of dry coal-gas, or 1½ per cent. of the total loss of sensible heat in the products.

### GAS-PRODUCER CALCULATIONS

The data on which the calculations must be based are : (i) the composition and quantity of fuel fired ; (ii) the composition of the gas ; since producer-gas is very seldom directly measured, the make of gas must be arrived at by calculation ; (iii) the quantity of solid refuse removed from the producer and the percentage of carbon therein ; (iv) the quantity of tar and its content of carbon and hydrogen. In order to arrive at reasonably correct materials and energy balances, it is necessary to know also the weight of coal or the number of units of electricity employed to operate the blower, and also the pressure of the steam used to saturate the blast and the blast-saturation temperature.

The method of solving gas-producer problems may be illustrated by the following example :

Coal fired per hour = 1288 lb.

Composition : C = 74.1 ; H = 5.1 ; N = 1.35 ; S = 0.95 ; O = 9.5 ;  
Ash = 4.0 ; Moisture = 5.0 per cent. Gross calorific value as  
fired = 13,200 B.Th.U.s. per lb.

Solid refuse withdrawn per hour = 56 lb., containing 44.7 per cent.  
carbon.

Anhydrous tar withdrawn per hour = 12.8 lb., containing C = 83.1 ;  
H = 8.5 per cent. Gross calorific value = 16,500 B.Th.U.s. per  
lb.

Composition of gas : CO<sub>2</sub> = 9.2 ; CO = 21.3 ; CH<sub>4</sub> = 3.4 ; H<sub>2</sub> = 19.7 ;  
N<sub>2</sub> = 46.4 per cent. Gross calorific value at N.T.P., 176  
B.Th.U.s. per cu. ft. Temperature leaving system, 200° C.

Percentage of nitrogen in the coal converted to ammonia = 35.  
Coal used to operate the blower = 56 lb. per hour. Steam used to

## Fuel Testing

saturate the blast was exhaust steam at 5 lb. gauge pressure. Blast saturation temperature = 70° C.

### i. Carbon gasified per hour.

Coal to producer, 1288 lb. at 74.1 per cent. carbon.

$$\text{Carbon to producer} = \frac{74.1 \times 12.88}{12} = 79.5 \text{ lb.-atoms.}$$

$$\text{Carbon withdrawn in solid refuse} = \frac{56 \times 0.447}{12} = 2.1 \text{ lb.-atoms.}$$

$$\text{Carbon withdrawn in tar} = \frac{12.8 \times 0.831}{12} = 0.9 \text{ lb.-atoms.}$$

Hence, carbon appearing in gas per hour = 79.5 - 3.0 = 76.5 lb.-atoms.

### ii. Gas made per hour.

Per 100 Lb.-Mols. Gas.		Lb.-Atoms C.	Lb.-Mols. H <sub>2</sub> .	Lb.-Mols. O <sub>2</sub> .
CO <sub>2</sub> . . .	9.2	9.2	—	9.2
CO . . .	21.3	21.3	—	10.65
CH <sub>4</sub> . . .	3.4	3.4	6.8	—
H <sub>2</sub> . . .	19.7	—	19.7	—
N <sub>2</sub> . . .	46.4	—	—	—
	100.0	33.9	26.5	19.85

100 lb.-mols. gas contain 33.9 lb.-atoms carbon, whence, from a carbon balance, gas made per hour =  $\frac{76.5 \times 100}{33.9} = 226$  lb.-mols., or,  $226 \times 359 = 81,000$  cu. ft. at N.T.P.

Gas made per lb. coal to producer = 63.0 cu. ft.

### iii. Carbon balance (producer only). Basis : 1 hour.

	Lb.-Atoms.	Lb.	Per Cent.
Carbon fired to producer	79.5	954	100.0
„ in gas . . .	76.5	918	96.2
„ „ solid refuse . . .	2.1	25.2	2.65
„ „ tar . . .	0.9	10.8	1.15
	<u>79.5</u>	<u>954.0</u>	<u>100.0</u>

## Gas-Producer Calculations

iv. *Air supplied to producer per hour.*—This is arrived at by means of a nitrogen balance.

$$\begin{aligned} \text{Nitrogen appearing in gases per hour} &= \frac{226 \times 46.4}{100} \\ &= 104.9 \text{ lb.-mols.} \end{aligned}$$

$$\begin{aligned} \text{Nitrogen from coal appearing in gases per hour} &= \frac{12.88 \times 1.35 \times 0.65}{28} \\ &= 0.4 \text{ lb.-mols.} \end{aligned}$$

∴ nitrogen introduced as atmospheric air = 104.5 lb.-mols. dry air supplied per hour =  $\frac{104.5}{0.791} = 132.1$  lb.-mols., or

$$132.1 \times 359 = 47,500 \text{ cu. ft. at N.T.P.}$$

v. *Steam introduced per hour.*

The air was saturated with steam at 70° C. at which temperature the vapour pressure of water is 233.6 mm. If the total pressure of the blast were 760 mm., partial pressure of dry air = 526.4 mm.

Hence, water vapour introduced per lb.-mol. dry air =  $\frac{233.6}{526.4} = 0.444$  lb.-mols., and total steam per hour =  $132.1 \times 0.444 = 58.6$  lb.-mols. 1055 lb. equivalent to 0.82 lb. per lb. of coal as fired.

vi. *Hydrogen balance.* Basis : one hour.

	Lb.-Mols.	Lb.	Per Cent.
Hydrogen supplied to producer—			
As hydrogen in coal, $2.55 \times 12.88$ . . . . .	32.8	65.6	34.5
„ moisture in coal, $0.28 \times 12.88$ . . . . .	3.6	7.2	3.8
„ steam in blast . . . . .	58.6	117.2	61.7
	95.0	190.0	100.0
Hydrogen withdrawn in tar, $12.8 \times \frac{0.085}{2}$	0.55	1.1	0.6
Hydrogen converted to ammonia, $\frac{1.35 \times 0.35 \times 1.5}{28}$ . . . . .	0.25	0.5	0.3
Hydrogen appearing in gas, $\frac{26.5 \times 226}{100}$	59.9	119.8	63.1
	60.7	121.4	64.0
Hydrogen leaving as steam in gas (by difference) . . . . .	34.3	68.6	36.0
	95.0	190.0	100.0

## Fuel Testing

### vii. *Percentage of steam decomposed.*

	Lb.-Mols.	Lb.
Undecomposed steam in gas per hour .	34.3	617.4
Steam from moisture in coal . . .	3.6	64.8
Steam equivalent of oxygen in coal, $\frac{12.88 \times 9.5 \times 2}{32}$ . . . . .	7.65	137.75
	11.25	202.55
Hence, steam in blast escaping decomposition . . . . .	23.05	414.9

Steam in blast decomposed = 35.55 lb.-mols. or 60.8 per cent., and steam decomposed per lb. of coal =  $0.608 \times 0.82 = 0.50$  lb.

### viii. *Oxygen balance.* Basis : one hour.

	Lb.-Mols.	Lb.	Per Cent.
Oxygen to producer—			
In air = $132.1 \times 0.209$ . . . . .	27.6	883.2	44.1
As steam in blast . . . . .	29.3	937.6	46.9
„ moisture in coal . . . . .	1.8	57.6	2.9
„ oxygen in coal . . . . .	3.8	121.6	6.1
	62.5	2000.0	100.0
Leaving as oxides of carbon in 226 lb.-mols. gas = $19.85 \times 2.26$ . . . . .	44.9	1436.8	71.8
As undecomposed steam $\frac{34.3}{2}$ . . . . .	17.15	563.2	27.5
	62.05	1985.6	100.0
Oxygen not accounted for . . . . .	0.45	14.4	0.7

### ix. *Nitrogen balance.* Basis : one hour.

	Lb.-Mols.	Lb.	Per Cent.
Nitrogen in 132 lb.-mols. air = $132.1 \times 0.791$ . . . . .	104.5	2926.0	99.4
Nitrogen in 1288 lb. coal = $\frac{1.35 \times 12.88}{28}$ . . . . .	0.6	16.8	0.6
	105.1	2942.8	100.0
Leaving free in gases = $46.4 \times 2.26$ . . . . .	104.9	2937.0	99.8
Converted to ammonia (35 % of N in coal) . . . . .	0.2	5.6	0.2
	105.1	2942.6	100.0

## Gas-Producer Calculations

### Heat Balance

The heat supplied to the producer is not only the potential heat in the coal fired (namely  $1288 \times 13,200$ , or 17,010,000 B.Th.U.s.) plus the sensible and latent heat in the blast above an assumed datum level of  $15^\circ \text{C}$ ., but must also include the potential heat in 56 lb. coal supplied per hour for the operation of the blower. The sensible heat in the air at  $15^\circ \text{C}$ . does not come into the calculation, since the assumed datum level is  $15^\circ \text{C}$ .

We therefore have :

<i>Dr.</i>		
	B.Th.U.s.	Per Cent.
Potential heat in 1288 lb. coal fired to producer . . . . .	17,010,000	90.3
Potential heat in 56 lb. coal used to operate blower . . . . .	739,300	3.9
Sensible and latent heat in 58.6 lb.-mols. exhaust steam at 5 lb. gauge pressure, $58.6 \times (1370 + 17,280)$ . . . . .	1,092,000	5.8
	18,841,000	100.0
 <i>Cr.</i> 		
Heat of combustion of 226 lb.-mols. gas at 176 B.Th.U.s. per cu. ft. at N.T.P., $226 \times 359 \times 176$ . . . . .	14,260,000	75.8
Heat of combustion of 12.8 lb. tar at 16,500 B.Th.U.s. per lb. . . . .	211,700	1.1
Heat of combustion of 25.0 lb. carbon in ashes and soot, $25 \times 14,540$ . . . . .	363,500	1.9
Sensible heat in dry gas at $200^\circ \text{C}$ ., above $15^\circ \text{C}$ . . . . .	550,300	2.9
Sensible and latent heat in 34.3 lb. mols. steam at $200^\circ \text{C}$ ., above water at $15^\circ \text{C}$ . . . . .	692,500	3.7
Balance, including heat dissipated by radiation and convection, sensible heat in ashes (slight) and error . . . . .	2,762,000	14.6
	18,841,000	100.0

*Note.*—To determine the heat in the steam in the gases it is necessary, first, to calculate its partial pressure, from which the latent heat of condensation may be derived. If total pressure of gases is 30 in. Hg, partial pressure of steam =  $\frac{\text{No. of lb.-mols. steam} \times 30}{\text{No. of lb.-mols. wet gases}} = \frac{34.3 \times 30}{226 \times 34.3} = 3.96$  in. Hg, whence temperature of condensation =  $124.6^\circ \text{F}$ . and latent heat = 18,270 B.Th.U.s. per lb.-mol. (Fig. 59). From Table XXIX, sensible heat per lb.-mol. at  $200^\circ \text{C}$ . ( $392^\circ \text{F}$ .) above  $125^\circ \text{F}$ . = 746 B.Th.U.s. per lb.-mol., and heat in water at  $125^\circ \text{F}$ . above  $59^\circ \text{F}$ . ( $15^\circ \text{C}$ .) = 1190 B.Th.U.s. per lb.-mol. Hence total heat per lb.-mol. = 20,200 B.Th.U.s. or per 34.3 lb.-mols. = 692,500.

## Fuel Testing

### NOTES ON THE GAS-PRODUCER CALCULATIONS

The calculations are intended to show how, from given data, it is possible to construct weight- and heat-balances.

P. 273. The weight of anhydrous tar is lower than would be produced in practice. A coal of the type considered might be expected to give 5 or 6 per cent. of tar and not 1 per cent. Although the numerical results would be different, the method of calculation would be the same.

P. 275. As has been pointed out to the Author by Mr. G. W. Andrew of the Federation of British Industries, there is a certain artificiality about attempts to calculate hydrogen-, steam- and oxygen balances. There may be droplets of liquid water carried forward into the blast with the steam, the result being that the blast-saturation temperature does not give a true picture of the quantity of water in the blast. With a wet-bottomed producer, an unknown quantity of water is evaporated from the water-seal and passes through the system as steam. These unknown quantities of extra water vapour pass out with the gases unchanged, since not all the hydrogen intentionally introduced into the system is accounted for, consequently in the balance-sheet there is an unknown quantity  $x$  lb.-mols. of steam appearing on both sides of the account. But, since  $x$  appears both as a debit and credit, from the point of view of the materials-balance, it can be neglected. In the heat-balance, however, the heat of converting this  $x$  lb.-mols. of liquid water into vapour and superheating it to the temperature of the gases leaving the producer should be taken into account, but since this cannot be done,  $x$  being unknown, thus it appears in the account among the "errors".

P. 276. In calculating the percentage of steam decomposition it is commonly assumed that the oxygen in the coal combines with its quota of hydrogen to form water. This is a convention which may or may not be true, but provided this is understood, there need be no misunderstanding about the significance of the calculation.

It will be observed that there is a deficit of 0.45 lb.-mols. of oxygen "unaccounted for". This arises from the fact that, in the analysis of the coal the "oxygen" is determined by difference and bears all the errors of the analysis, and that the tar, soot and solid refuse certainly were not free from oxygen, although complete analyses were not furnished, while in addition, slight, but inevitable errors in the analysis of the gas cannot fail to have some effect on the final calculations.

DISSOCIATION

Quite apart from incomplete combustion which may result from a local or general deficiency of oxygen in the combustion chamber, combustion may be incomplete owing to the fact that at high temperatures water vapour and carbon dioxide are dissociated. Even in the presence of an excess of oxygen, *in the flame itself*, combustion is rarely completed, but an equilibrium is set up between the fuel gases, the oxygen and the products of combustion (CO<sub>2</sub> and water vapour). This failure for combustion to be complete may be of importance in furnaces which are operated at high temperature, and may necessitate the use of extra fuel in order to supply the heat necessary to compensate for that part of the heat of combustion of the fuel gases which is not realised in the hottest zone of the furnace. The degree of incompleteness of combustion may be calculated from a knowledge of the composition of the gaseous mixture, the temperature within the furnace and the equilibrium constants of the reactions. It is necessary to assume that equilibrium is attained in order to make the calculation; this assumption is justified in practice, since at high temperatures, equilibrium is very rapidly established.

Taking, for example, the producer-gas already considered, the gas being burned with 20 per cent. excess air and used to fire a furnace at 2000° C. To attain such a high temperature, both gas and air would have to be preheated, prior to which the gas would be cleaned and washed to remove dust which would otherwise tend to choke the passages in the regenerator; the gas may be expected to leave the cleaning plant saturated with water vapour at 20° C.

Basis: 100 lb.-mols. dry producer-gas

	Lb.-Mols.	Lb.-Mols. Oxygen Required.
CO <sub>2</sub> . . . .	9.2	—
CO . . . .	21.3	10.65
CH <sub>4</sub> . . . .	3.4	6.8
H <sub>2</sub> . . . .	19.7	9.85
N <sub>2</sub> . . . .	46.4	—
		27.30

100 lb.-mols. gas require 27.30 lb.-mols. oxygen for complete combustion, or if 20 per cent. excess air be used, 32.76 mols., equivalent to 156.8 lb.-mols. air, which may be assumed to be 60 per cent. saturated at 15° C.



## Fuel Testing

Water vapour introduced per 100 lb.-mols. dry producer-gas

$$= \frac{17.6 \times 100}{742.4} = 2.37 \text{ in gas}$$

$$= \frac{0.6 \times 12.8 \times 156.8}{(760 - 7.7)} = 0.79 \text{ in air}$$

Total = 3.16 lb.-mols.

The products per lb.-mols. (assuming combustion to be complete) would then be :

Lb.-Mols.			Per Cent by Volume.	
			Wet Gases.	As Analysed.
CO <sub>2</sub> . . . . .	33.9	33.9	14.1	16.1
Water vapour from H <sub>2</sub> . . . . .	26.5	29.7	12.4	—
„ „ „ gas and air . . . . .	3.2			
O <sub>2</sub> . . . . .	5.5	5.5	2.3	2.6
N <sub>2</sub> from gas . . . . .	46.4	170.4	71.2	81.3
„ air . . . . .	124.0			
		239.5		

The dissociation reactions which must be considered are :  $\text{CO} + \frac{1}{2}\text{O}_2 \rightleftharpoons \text{CO}_2$  and  $\text{H}_2 + \frac{1}{2}\text{O}_2 \rightleftharpoons \text{H}_2\text{O}$ , and the equilibrium constants (derived from Table XXXI) at 2000° C. are 92 and 540 respectively. Note that the partial pressures of the components of the systems are expressed in atmospheres. Since the waste gases will be at a pressure very close to one atmosphere, the partial pressures of the components of the mixture will be one-hundredth of the percentages by volume, i.e.  $\text{CO}_2 = 0.141$ , steam = 0.124, and oxygen = 0.023. If  $x$  is the amount (in atmospheres) of  $\text{CO}_2$  dissociated, the partial pressure of  $\text{CO}_2 = 0.141 - x$ , of  $\text{CO} = x$ , and of oxygen =  $0.023 - x/2$ , since the gases contain 0.023 atmospheres of oxygen initially. Hence,  $\frac{0.141 - x}{x\sqrt{0.023 + x/2}} = 92$ . This is a cubic equation, but solving by trial and error,  $x = 0.0075$ , and the percentage of  $\text{CO}_2$  dissociated =  $\frac{0.75}{0.141} = 5.32$ . Similarly, if  $y$  be the amount of steam dissociated,

$$\frac{0.124 - y}{y\sqrt{0.023 + y/2}} = 540.$$

Again, solving by trial and error,  $y = 0.00049$ , and the percentage of steam dissociated =  $\frac{0.049}{0.124} = 0.4$ .

TABLE XXXI

EQUILIBRIUM CONSTANTS OF GASEOUS REACTIONS

Temp. °C.	Dissociation of Water Vapour.	Dissociation of CO <sub>2</sub> .	Producer-Gas Equilibrium.	Water-Gas Equilibrium.
	$K_p = \frac{p_{H_2O}}{p_{H_2} \sqrt{p_{O_2}}}$	$K_p = \frac{p_{CO_2}}{p_{CO} \sqrt{p_{O_2}}}$	$K_p = \frac{p^2_{CO}}{p_{CO_2}}$	$K_p = \frac{p_{CO} \times p_{H_2O}}{p_{CO_2} \times p_{H_2}}$
500	5.7 × 10 <sup>13</sup>	3.5 × 10 <sup>14</sup>	3.3 × 10 <sup>-3</sup>	(0.3)
600	7.1 × 10 <sup>11</sup>	2.2 × 10 <sup>13</sup>	6.2 × 10 <sup>-2</sup>	(0.4)
700	2.2 × 10 <sup>10</sup>	3.9 × 10 <sup>10</sup>	6.2 × 10 <sup>-1</sup>	0.6
800	1.3 × 10 <sup>9</sup>	1.5 × 10 <sup>9</sup>	3.9	0.9
900	1.2 × 10 <sup>8</sup>	9.9 × 10 <sup>7</sup>	1.8 × 10	1.3
1000	1.7 × 10 <sup>7</sup>	1 × 10 <sup>7</sup>	6.5 × 10	1.7
1100	3.0 × 10 <sup>6</sup>	1.5 × 10 <sup>6</sup>	1.9 × 10 <sup>2</sup>	2.1
1200	6.95 × 10 <sup>5</sup>	2.7 × 10 <sup>5</sup>	4.9 × 10 <sup>3</sup>	2.5
1300	1.9 × 10 <sup>5</sup>	6.5 × 10 <sup>4</sup>	1.1 × 10 <sup>3</sup>	3.0
1400	6.1 × 10 <sup>4</sup>	1.8 × 10 <sup>4</sup>	2.2 × 10 <sup>3</sup>	3.4
1600	9.0 × 10 <sup>3</sup>	2.1 × 10 <sup>3</sup>	7.1 × 10 <sup>3</sup>	4.2
1800	1.9 × 10 <sup>3</sup>	3.8 × 10 <sup>3</sup>	—	5.1
2000	5.4 × 10 <sup>2</sup>	9.2 × 10	—	5.8
2200	1.8 × 10 <sup>2</sup>	2.8 × 10	—	6.6
2400	7.5 × 10	1.0 × 10	—	7.3
2600	3.5 × 10	4.3	—	8.1
2800	1.8 × 10	2.0	—	8.9

\* Composite figure for values from coke, charcoal and amorphous carbon.

Note.—Concentrations are expressed as partial pressures in atmospheres.

Reproduced, by permission, from "Modern Furnace Technology," by H. Etherington. Charles Griffin & Co. Ltd., 1938.

The gases will therefore consist of :

	Lb.-Mols.	Per Cent. by Volume.	
		Wet Gases.	Dry Gases.
CO <sub>2</sub> 33.9 × 0.9468 .	32.1	13.34	15.22
CO 33.9 × 0.0532 .	1.8	0.75	0.85
Steam 29.7 × 0.996 .	29.58	12.30	—
H <sub>2</sub> 29.7 × 0.004 .	0.12	0.05	0.06
O <sub>2</sub> 0.90 + 0.06 + 5.5	6.46	2.76	3.14
N <sub>2</sub> 170.4 . . . .	170.4	70.80	80.73
	<u>240.56</u>	<u>100.00</u>	<u>100.00</u>

## Fuel Testing

And the undeveloped heat per 100 lb.-mols. dry producer-gas will be

$$\text{due to dissociation of steam} = 0.12 \times 104,560 = 12,550 \text{ B.Th.U.s.}$$

$$\text{due to dissociation of CO}_2 = 1.8 \times 121,721 = 219,100 \quad ,,$$

$$\text{Total} = \underline{231,650} \quad ,,$$

$$\text{or } \frac{231,650}{359 \times 176} = 3.87 \text{ per cent. of the heat of combustion of the gas.}$$

A graphical method for the evaluation of dissociation has been developed by A. J. V. Underwood, "Technical Data on Fuel," 4th edition (1935), p. 223.

## INDEX

	PAGE		PAGE
ABEL Flash-Point Apparatus . . . . .	213	Bone, W. A., and Silver, L., Deter-	
Alkalies, Determination of Lawrence		mination of Volatiles on Coal	30-32
Smith Method . . . . .	133	Types of Residue . . . . .	32
American Chemical Society, Variations		Boys, C. V., Gas Calorimeter . . . . .	187
in successive Determinations		British Standards Institution, Sam-	
of Ash . . . . .	2	pling Committee . . . . .	2, 3
Andrew, G. W., on Gas-Producer		Burdekin, J. T., Caking Power of	
Calculations . . . . .	279	Coal . . . . .	38
Arsenic in Coal—		Burrell, Seibert and Robinson,	
British Standard Method . . . . .	62	Fractionation of Gases by Liquid	
Determination . . . . .	61	Air . . . . .	173
Fuel Research Board Method . . . . .	65	Bushell, L. A., Average Error South	
Ash, Analysis of . . . . .	126-135	African Coals . . . . .	3
Alkalies . . . . .	133	Suction-Drill Sampling of Coal . . . . .	20
Aluminium . . . . .	129		
Calcium . . . . .	130	CALORIFIC Value—	
Iron . . . . .	129, 132	At Constant Pressure . . . . .	89
Iron, Separation from Aluminium		Ditto Volume . . . . .	88
and Titanium . . . . .	128, 130	Gross and Nett. . . . .	90, 192
Magnesium . . . . .	130	Calorific Value. Solid and Liquid	
Manganese . . . . .	130	Fuels—	
Silica . . . . .	127	Direct Determination . . . . .	73, 80
Titanium . . . . .	129, 132	Indirect Determination . . . . .	73
Ash, Determination in Coal . . . . .	34	Dulong . . . . .	75
Ditto Coke . . . . .	47	Gouthal . . . . .	78, 79
Ditto Liquid Fuels . . . . .	226	Grumell and Davies . . . . .	76, 80
Ash, Fusion Point of . . . . .	136-143	Mahler . . . . .	76
Control of Furnace Atmosphere		Nakamura . . . . .	79, 80
. . . . .	140, 143	White . . . . .	77
Influence of Atmosphere on . . . . .	138	Calorimeters—	
Influence of Iron Oxides on . . . . .	137	Accuracy of Results . . . . .	74, 75, 88
Losses Caused by Low Fusion-		Bomb . . . . .	80
Point . . . . .	136	Cooling Correction . . . . .	85
Measurement of Temperature in		Correction for Acids Formed . . . . .	85
Determination . . . . .	140	Effect of Acid Attack on Lining . . . . .	81
Method of Determination . . . . .	139	Low Pressure Oxygen . . . . .	73
Ash, Low-Melting, Disadvantages of	136	Operation of . . . . .	83
Relation to Mineral Matter in		Sodium Peroxide, Effect of Ash in	75
Coal . . . . .	115	Specification of Accessories . . . . .	81
		Water Equivalent . . . . .	87
BELCHER, R., and Spooner, C.E.,		Calorimetry, Definitions . . . . .	73, 180, 199
Determination of Carbon, Hydro-		Gas . . . . .	180-201
gen, Sulphur and Chlorine in Coal	51	Solid and Liquid Fuels . . . . .	73-91
Blythe, M. W., and O'Shea, D., Size		Campredon, L., Caking Power of Coal	38
of Sample for Coal Cleaning Tests	117	Carbon, Determination in Coal . . . . .	48
Bone, W. A., and Jerdan, J. S., De-		Accuracy of Determination . . . . .	51
termination of Hydrogen by		Determination in Coke . . . . .	60
Means of Palladium . . . . .	154	Carbon Dioxide in Coal, Determin-	
Bone, W. A., and Newitt, D. M., Gas		ation . . . . .	65
Analysis Apparatus . . . . .	157, 163		

## Fuel Testing

	PAGE		PAGE
Carbonisation Assay of Coal . . . . .	94-113	Coal, Miscellaneous Determinations—	
High Temperature . . . . .	105-113	Arsenic . . . . .	61-65
Apparatus . . . . .	105	British Standard Method . . . . .	62
Average Gas, Specific Gravity and		Duck on ditto . . . . .	63
Composition . . . . .	107	Fuel Research Board Method . . . . .	65
Correlation with Continuous		Carbon Dioxide . . . . .	65
Vertical Retorts . . . . .	111	Chlorine . . . . .	51, 70
Correlation with Horizontal		Phosphorus . . . . .	67
Retorts . . . . .	109	Soluble Mineral Salts . . . . .	71
Method of Operation . . . . .	107	Sulphur, Fixed and Volatile . . . . .	61
Scope of Method . . . . .	108	Coal, Proximate Analysis . . . . .	28-37
Carbonisation Assay of Coal—		Ash . . . . .	34
Low Temperature . . . . .	94-105	Classification based on . . . . .	37
Apparatus . . . . .	95	Fixed Carbon . . . . .	37
Correlation with Large-Scale		Moisture . . . . .	11, 29
Practice . . . . .	94, 103	Reporting . . . . .	35
Effect of Size of Tube . . . . .	101	Volatiles . . . . .	28, 30-34
Gas Calculations . . . . .	102	Coal, Purchase under Contract . . . . .	249
Method of Operation . . . . .	97	Coal, Sampling, <i>vide</i> "Sampling".	
Notes on Manipulation . . . . .	98	Coal, Selection for Industrial Uses	
Presentation of Results . . . . .	101	Domestic Purposes . . . . .	242-254
Standard Descriptions of Coke	101	Gas-Producers . . . . .	248
Strongly Swelling Coals . . . . .	100	Low Temperature Carbonisation . . . . .	248
Cave, G. A., Determination of		Manufacture of Metallurgical Coke . . . . .	245
Pyritic Sulphur in Coal . . . . .	58	Pulverised Fuel Firing . . . . .	248
Chapman, W. R., and Mott, R. A.,		Steam Raising . . . . .	243
Grading of Samples for Coal		Town's Gas Manufacture . . . . .	247
Cleaning Tests . . . . .	117	Coal, Swelling Propensity . . . . .	42-45
Chlorine in Coal, Determination of	51, 70	Coal, Ultimate Analysis . . . . .	48-59
Clinker, Formation of . . . . .	136	Carbon and Hydrogen Determina-	
Coal, Agglutinating Value . . . . .	38-41	tion . . . . .	48
Analysis of, <i>vide</i>		Accuracy of Results . . . . .	51
Coal, Proximate Analysis . . . . .	28-37	Nitrogen . . . . .	52
Miscellaneous Determinations	61-72	Oxygen . . . . .	59
Ultimate Analysis . . . . .	48-60	Sulphur—	
Coal, Analytical Results—		Bomb-Washing Process . . . . .	54
Permissible Differences . . . . .	93	Eschka Process . . . . .	53
Reproducibility . . . . .	92	Organic . . . . .	55, 58
Coal, Caking Power . . . . .	38-41	Pyritic . . . . .	55-58
Coal, Calorific Value . . . . .	73-81	Sulphate . . . . .	55-57
Coal Cleaning, Advantages of . . . . .	116	Coke, Permissible Limits of Sulphur	
Application of Test Results to		and Phosphorus in Smelting	
Practice . . . . .	125	Hematite . . . . .	246
Efficiency . . . . .	125	Proximate Analysis—	
Float-and-Sink Tests . . . . .	122	Ash . . . . .	47
Instantaneous Ash Curves	120, 121, 124	Moisture . . . . .	45
Integral Ash Curves . . . . .	120, 121, 124	Volatiles . . . . .	46
Jig Tests, Henry Tube . . . . .	118	Coke, Sampling, <i>vide</i> "Sampling".	
Over-Cleaning . . . . .	116	Ultimate Analysis—	
Selection of Samples for Test . . . . .	117	Carbon and Hydrogen . . . . .	60
Coal, Heterogeneity of . . . . .	1, 2	Sulphur . . . . .	60
Coal, Mineral Matter in . . . . .	114-125	Combustion Calculations . . . . .	259-283
Alteration of During Determina-		Air Required, Gaseous Fuels . . . . .	265
tion of Ash . . . . .	114	Ditto Solid and Liquid	
Effect on Utilisation of Coal . . . . .	116	Fuels . . . . .	259
Extrinsic . . . . .	114	Air Used . . . . .	265, 267
Intrinsic or Inherent . . . . .	114	Dissociation . . . . .	280
Origin of . . . . .	114	Incomplete Combustion . . . . .	263, 267
Relation to the Ash . . . . .	115		

# Index

	PAGE		PAGE
<b>Combustion Calculations—cont.</b>		<b>Gas Analysis: Apparatus—cont.</b>	
Loss of Heat in Waste Gases . . . . .	268	Hays' Modification of the Orsat	
Moisture, Effect on Loss of Heat in		Apparatus . . . . .	162
Waste Gases . . . . .	272	Absorbents for . . . . .	163
<b>Combustion Equations, Funda-</b>		Sampling Bulbs . . . . .	163
<b>mental . . . . .</b>	267	<b>Gas Analysis—</b>	
<b>Conradson, Test for Carbon Re-</b>		Apparatus, Improved Hempel	158-162
<b>sidue in Petroleum Oils . . . . .</b>	220	Absorption Pipettes . . . . .	160
<b>Crossley, H. E., Determination of</b>		Compensating Device . . . . .	159
<b>Nitrogen in Coal . . . . .</b>	53	Explosion Pipette . . . . .	161
<b>DEAN and Stark, Determination of</b>		Measuring Burettes . . . . .	169
<b>Water in Liquid Fuels . . . . .</b>	218	Effect of Moisture in . . . . .	157
<b>Down, A. L., Analysis of Oil Shales</b>	59	<b>Gas Analysis—</b>	
<b>Drakeley, T. J., Efficiency of Coal</b>		Explosion and Combustion	
<b>Cleaning . . . . .</b>	125	Methods . . . . .	151-156
<b>Duck, N. W., Determination of</b>		Preferential Combustion of Hy-	
<b>Arsenic in Coal . . . . .</b>	62, 64	drogen by Copper Oxide . . . . .	154
<b>Dulong, Calculation of the Calorific</b>		Strength of Mixture . . . . .	153
<b>Value of Coal . . . . .</b>	75	Use of the C/A Ratio . . . . .	153
<b>Dunn, J. T., Caking Power of Coal .</b>	38	Volumetric Changes . . . . .	153
<b>EATON, F. J., Wet and Dry Bulb</b>		<b>Fractionation by Liquid Air</b>	173-176
<b>Hygrometer . . . . .</b>	200	<b>Miscellaneous Determinations—</b>	
<b>Edwards, A., Marson, H., and</b>		Ammonia in Coal-Gas and	
<b>Briscoe, H. V. A., Determination</b>		Coke-Oven Gas . . . . .	177
<b>of Phosphorus in Coal . . . . .</b>	72	Benzol in Coal-Gas and Coke-	
<b>Etherington, H., Equilibrium Con-</b>		Oven Gas . . . . .	178
<b>stants . . . . .</b>	282	Hydrogen Sulphide in Coal-Gas	
<b>FÉRY, Radiation Pyrometer . . . . .</b>	235	and Coke-Oven Gas . . . . .	100
<b>Fieldner, A. C., Hall, A. E., and</b>		Naphthalene in Coal-Gas and	
<b>Feild, A. L., Ash Cones for</b>		Coke-Oven Gas . . . . .	178
<b>Determining the Fusion-Point of</b>		Unsaturated Hydrocarbons,	
<b>Coal Ash . . . . .</b>	140	Separation of . . . . .	176
<b>Fieldner, A. C., and Selvig, W. A.,</b>		<b>Gas Calorimetry—</b>	
<b>Influence of Carbon Monoxide</b>		Apparatus for . . . . .	185-201
<b>and Hydrogen on the Fusion</b>		Boys Calorimeter . . . . .	187
<b>of Coal Ash . . . . .</b>	138	Jones-Miller . . . . .	193
<b>Classification of Clinkering Pro-</b>		Conditions which Must be Ful-	
<b>cessity in Coals . . . . .</b>	243	filled . . . . .	182
<b>Foster, Disappearing Filament Py-</b>		Notes on Calculation of Results .	191
<b>rometer . . . . .</b>	235	<b>Gas Governor . . . . .</b>	186
<b>Radiation Pyrometer . . . . .</b>	237	<b>Gas, Partial Drying of, Determina-</b>	
<b>Fusion Pyrometers . . . . .</b>	238	<b>tion of Dew-Point . . . . .</b>	199, 200
<b>GAS Analysis . . . . .</b>	149-179	<b>Gas Producer, Calculations, Heat</b>	
Absorbents . . . . .	149	Balance . . . . .	273-277
Preparation of . . . . .	150, 170	<b>Gas Referees, Notification . . . . .</b>	183, 188
Apparatus . . . . .	157-176	<b>Gaseous Reactions, Equilibrium</b>	
Bone and Newitt . . . . .	157, 163-172	Constants . . . . .	280
Care of Glass Taps . . . . .	164	<b>Gases, Calorific Value—</b>	
Cleaning . . . . .	171	Calculation . . . . .	180
Introducing the Gas . . . . .	167	Determination . . . . .	182, 201
Method of Operation . . . . .	166	Gross . . . . .	192
Preparation of Reagents . . . . .	170	Nett . . . . .	193
Selective Absorption of Con-		<b>Gases, Heats of Combustion of . . . . .</b>	180
stituents . . . . .	168	<b>Gases, Sampling, <i>vide</i> "Sampling".</b>	
Setting up the Apparatus . . . . .	164	<b>Gee, E. R., Cleaning Test on an</b>	
		Indian Coal . . . . .	124
		<b>Gouthal, Calculation of the Calorific</b>	
		Value of Coal . . . . .	78

# Fuel Testing

	PAGE		PAGE
Gray, T., Heriot, T. H. P., and Skilling, W. J., Caking Power of Coal . . . . .	39, 41	Kjeldahl, Determination of Nitrogen in Coal . . . . .	52
Gray, T., and King, J. G., Carbonisation Assay of Coal . . . . .	113	Determination of Nitrogen in Coke . . . . .	60
Griffin-Sutton Bomb Calorimeter . . . . .	82	LAWRENCE SMITH, J., Determination of Alkalies in Coal Ash . . . . .	133
Grumell, E. S., and Davies, I. A., Calculation of the Calorific Value of Coal . . . . .	76	Liquid Fuels . . . . .	202-226
Grumell, E. S., and Dunningham, A. C., Sampling of Coal . . . . .	2, 3	Ash . . . . .	226
Gutzeit, Determination of Arsenic . . . . .	62	Asphaltenes . . . . .	223
HANCOCK, W. C., Analysis of the Ash from Coal and Coke . . . . .	126	Calorific Value . . . . .	226
Hays, J., Gas Analysis Apparatus . . . . .	162	Carbon Residue . . . . .	220
Hempel, Improved Gas Analysis Apparatus . . . . .	158	Flash-Point . . . . .	211-217
Wheeler's Modification of . . . . .	162	Abel Apparatus . . . . .	213
Henry Tube for Coal Cleaning Tests . . . . .	118	Pensky-Martens Apparatus . . . . .	215
Hiles, J., and Thompson, J. K., Electric Furnace for Determination of Fusion-Point of Coal Ash . . . . .	143	Pour-Point . . . . .	224
Hillebrand, W. F., and Lundell, G. E. F., Determination of Iron by Titanous Sulphate . . . . .	57	Sediment Insoluble in Benzene . . . . .	217
Hyde, C. G., and Mills, F. E.—Comparison of Calculated with Determined Calorific Values of Gases . . . . .	182	Sulphur . . . . .	226
Corrections in Gas Calorimetry . . . . .	183	Viscosity . . . . .	206-211
Effect of Variation of Temperature of Water to Calorimeter . . . . .	183	Kinematic in Absolute Units . . . . .	209
Hydrogen—Determination in Coal . . . . .	48	Redwood Viscometer . . . . .	207
Ditto Coke . . . . .	60	Water in . . . . .	218
Accuracy of . . . . .	51	Liquid Fuels, Sampling, <i>vide</i> "Sampling".	
Determination in Gases by—Combustion over Copper Oxide . . . . .	155	Lunge, G., and Ambler, H. R.—Determination of Benzol in Coal-Gas . . . . .	178
Explosion . . . . .	151	Fluorescin as Indication in Determining Ammonia in Coal-Gas . . . . .	177
Palladium . . . . .	154	Determination of Naphthalene in Coal-Gas . . . . .	178
Hydrogen Sulphide, Determination in Coal-Gas . . . . .	99	MAHLER, Calculation of the Calorific Value of Coal . . . . .	76
INSTITUTE of Petroleum, Chemical Standardisation Committee . . . . .	202	Manning, A. B., King, J. G., and Sinnatt, F. S., Unsaturated Hydrocarbons in Gases . . . . .	169
JONES, J. H., and Miller, J. M., Small-Scale Gas Calorimeter . . . . .	193	Mantel, W., and Radmacher, W., Determination of Pyritic Sulphur in Coal . . . . .	58
KING, J. G., and Edgcombe, L. J., Assay of Coal . . . . .	113	Meade, Alwyne, Ammonia in Coal-Gas . . . . .	177
Combustion of Hydrogen by Copper Oxide . . . . .	155	Molal Sensible Heats of Gases . . . . .	268
King, J. G., Maries, M. B., and Crossley, H. E., Relation of Ash to the Mineral Matter in Coal . . . . .	52, 115	Molecular Volume in British Units . . . . .	102
King, J. G., Tasker, C., and Edgcombe, L. J., Assay of Coal . . . . .	113	Morgan, G. T., and Davies, G. R., Germanium and Gallium in Coal Ash . . . . .	135
		Müller, Determination of Benzol in Coal-Gas . . . . .	178
		NAKAMURA, K., Calculation of the Calorific Value of Coal . . . . .	79
		Nitrogen, Determination in Coal . . . . .	52
		Ditto Coke . . . . .	60
		Northern Coke Research Committee . . . . .	67

## Index

	PAGE		PAGE
OIL Shales, Analysis of . . . . .	59	Sampling Coke— <i>cont.</i>	
Optical Pyrometers—		Increments . . . . .	23, 24
"Black Body" Conditions . . . . .	234	Moisture Samples . . . . .	26
Disappearing Filament . . . . .	235	Preparation of Samples for	
Oxygen in Coal, Determination . . . . .	59	Analysis . . . . .	26
Errors in . . . . .	115	Sampling Gases . . . . .	144-149
PENSKY-MARTENS Flash-Point Ap-		Bulbs . . . . .	147
paratus . . . . .	215	Bulk Samples . . . . .	148
Phosphorus in Coal, Determination . . . . .	67	Confining Liquids . . . . .	148
Powell, A. R., and Parr, S. W.,		Constant-Head Sampler . . . . .	148
Distribution of Sulphur in Coal . . . . .	56	Dead Pockets . . . . .	146
Pyrometry . . . . .	227-241	Pipes for . . . . .	144
General Methods of Determining		Positions for Taking . . . . .	146
Temperature . . . . .	227	Snap Samples . . . . .	147
RADIATION—		Sampling Liquid Fuels . . . . .	202-205
Correction for in Calorimetry . . . . .	85	Bottle Sampling . . . . .	204
Effect of in Measuring the Tem-		Containers for Samples . . . . .	205
perature of Gases . . . . .	240	Types of Samples . . . . .	202
Redwood Viscometer . . . . .	206	Sampling, Average Error . . . . .	2, 3, 5, 22
Regnault Pfaunder Radiation Cor-		Probable Error . . . . .	2
rection . . . . .	85	Schack, A., Suction Pyrometers . . . . .	241
Derivation of . . . . .	90	Séger Cones, Melting-Points . . . . .	238
Resistance Pyrometers . . . . .	243	Siemens Pyrometer . . . . .	239
SAMPLES, Coal, Containers for . . . . .	19	Simpkin, N., and Jones, E. H.,	
Liquid Fuels, Containers for . . . . .	205	Determination of Sulphur in Coal . . . . .	54
Sampling Coal . . . . .	1-23	Sinnatt, F. S., and Grounds, A.,	
Accuracy Required . . . . .	1, 5	Caking Power of Coal . . . . .	38, 39
Average Error . . . . .	2, 3, 5, 22	Sinnatt, F. S., and Wood, C. G.,	
from Barrows . . . . .	7	Effects of Over-Cleaning Coal . . . . .	116
Chutes . . . . .	6	Slater, L., Caking Power of Coal . . . . .	38
Conveyers . . . . .	6	Soluble Mineral Salts in Coal, De-	
Piles . . . . .	9	termination . . . . .	71
Wagons . . . . .	7	Steam at Low Pressures, Properties	
Gross Samples—		of . . . . .	270
Collection . . . . .	6-9	Stockings, W. E., Fractionation of	
Dividing . . . . .	17	Gases by Liquid Air . . . . .	173
Treatment of . . . . .	9-19	Suction Pyrometers . . . . .	241
Weights of . . . . .	4, 5, 8, 9	Sulphur, Correction for in Calori-	
Increments . . . . .	3, 4, 5	metry . . . . .	85
Moisture Samples . . . . .	10-15	Determination in Coal	
Collecting . . . . .	10	Bomb-Washing Method . . . . .	54
Determination of Moisture in . . . . .	11	Eschka Process . . . . .	53
Preparation of Samples for		Determination in Coke . . . . .	60
Analysis . . . . .	15	Determination in Liquid Fuels . . . . .	226
Suction-Drill Method . . . . .	20	Distribution in Coal . . . . .	55-58
Sampling Coke . . . . .	23-27	Fixed and Volatile in Coal . . . . .	61
Accuracy Required . . . . .	23	Permissible Limits in Metallurgi-	
for Performance and Efficiency		cal Coke . . . . .	246
Tests . . . . .	25	TAYLOR, R. A. A., and Patterson,	
from Barrows, Chutes, and Con-		W. S., on the Gouthal Formula . . . . .	78
veyers . . . . .	24, & 6-9	Technical Reports, Writing . . . . .	254-258
Wagons . . . . .	23	Temperature of Gases in Flues . . . . .	240
Gross Samples—		Thermo-Electric Pyrometers . . . . .	229-233
Collection . . . . .	23	Calibration . . . . .	232
Reduction of . . . . .	25	Characteristics of Thermo-	
Weights of . . . . .	24, 25	Junctions . . . . .	230
		Cold-Junction Control . . . . .	231
		Requirements of Couple-Wires . . . . .	230



## Fuel Testing

	PAGE		PAGE
Thermometers—		VOGEL, J. C., Suction-Drill Sampling of Coal	20, 21
Distance . . . . .	228	WASHABILITY of Coal . . . . .	116-125
Mercury-in-Steel . . . . .	228	Wheeler, R. V., Modification of Hempel Gas Analysis Apparatus	162
Vapour-Pressure . . . . .	229	White, D., Calculation of the Calorific Value of Coal . . . . .	77
Mercury-in-Glass . . . . .	227	Woodall-Duckham Co., Test for the Swelling Propensity of Coal . . . . .	42
Total Radiation Pyrometers . . . . .	235-238	YANCEY, H. F., and Fraser, T., Efficiency of Coal Cleaning . . . . .	125
Féry . . . . .	235		
Foster . . . . .	237		
UNDERWOOD, A. J. V., On Dissociation of Gases . . . . .	283		
U-Tube Viscometer for Liquid Fuels	210		

# **PURIFICATION OF WATER**

**FOR ALL PURPOSES**

BOILER FEED  
PROCESS WORK  
TEXTILE PURPOSES  
TOWN SUPPLY, Etc.

**IS THE SPECIALITY OF  
JOHN THOMPSON**

**(KENNICOTT WATER SOFTNERS) LTD**

*HEAD OFFICE AND WORKS*

**WOLVERHAMPTON**

*Established Half a Century*

PLACE YOUR WATER PROBLEMS  
BEFORE US AND AVAIL YOUR-  
SELF OF OUR

**Unrivalled Experience**

*Also Manufacturers of Continuous Blow-Down Apparatus  
for Boilers*

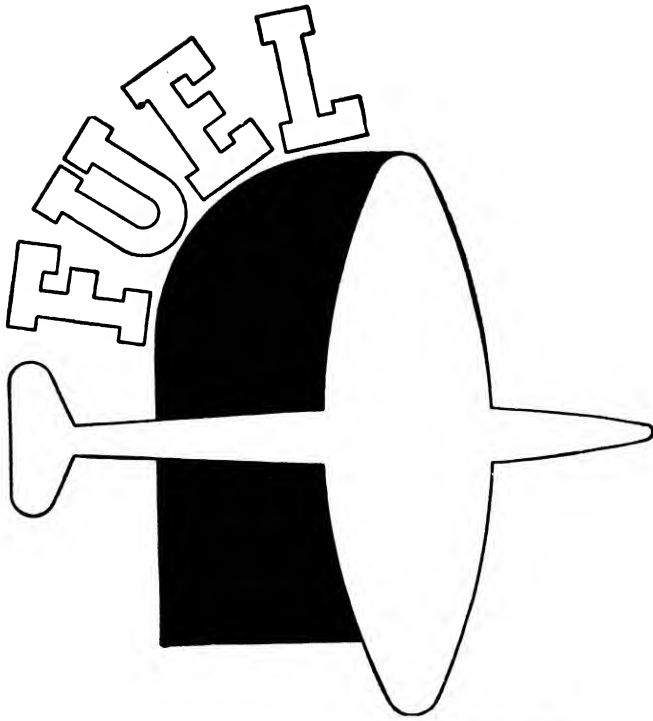

# TANKS

*Designers and Manufacturers in*  
LIGHT & ULTRA LIGHT ALLOYS

COVERING A WIDE RANGE OF FUEL AND OIL CONTAINERS  
INCLUDING HEAT-INSULATED AND HIGH INTERNAL  
PRESSURE TANKS. • INTERESTED IN ALL  
PROBLEMS CONCERNING LIQUID CONTAINERS

**ESSEX AERO LTD**

L O N D O N    E A S T    A I R P O R T .

G R A V E S E N D ,    K E N T .

TELEPHONE GRAVESEND 4261-2-3-4

# **FOSTER PYROMETERS**

ALL TYPES FOR ALL TEMPERATURES

**Foster Instrument Co. Ltd.**  
**LETCHWORTH, HERTS.**

*Telephone : Letchworth 26 and 626*

*Telegrams : " Resilia, Letchworth "*

**ERMETO**

# SAFETY PIPE COUPLINGS

For **COPPER, STEEL, and all other METAL TUBES**  
up to 2 ins. Outside Diameter

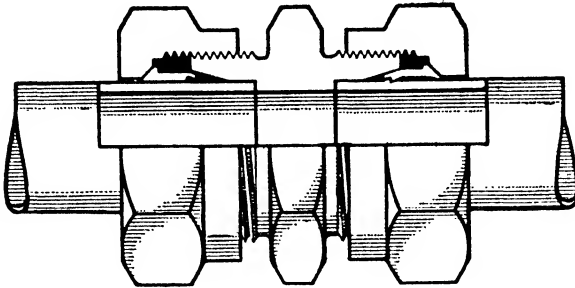

BEFORE ASSEMBLY

AFTER ASSEMBLY

NOTE HOW THE SEALING RING PLOUGHS INTO THE SURFACE OF THE TUBE,  
MAKING A JOINT LEAK-PROOF AGAINST ALL CONDITIONS OF  
PRESSURE, TEMPERATURE AND VIBRATION

**NO WELDING, BRAZING OR SOLDERING**  
**NO SCREWING OR EXPANDING OF TUBES**  
**ONLY SPANNERS REQUIRED FOR ASSEMBLY**  
**DISMANTLED AND RE-MADE WITHOUT REPLACEMENTS**

FOR STEAM, AIR AND ALL OTHER GASES  
FOR WATER, OIL, TAR AND ALL OTHER LIQUIDS  
MAX. PRESSURE 25,000 LB. PER SQ. IN., MAX. TEMPERATURE 800° F.

THE TUBE WILL BURST  
BEFORE THE **ERMETO** FITTING FAILS

**BRITISH ERMETO CORPORATION LTD.**  
**BEACON WORKS, MAIDENHEAD**

TELEPHONE: MAIDENHEAD 2271-2-3-4

TELEGRAMS: GRAMBON, MAIDENHEA

# DISTILLED WATER

. . . has hitherto only been obtainable by "Distillation." It is possible to-day by The **Permutit** Company's new and exclusive "**Deminrolit**" process to obtain large quantities of its equivalent cheaply and simply. This revolutionary process has already found its place in World Industry and plants are in operation for varied uses including Boiler Feed. It is fully described in our Booklet:—

## **DISTILLED WATER WITHOUT DISTILLATION**

Write for a copy to—The **PERMUTIT** Company Limited, Dept. S.B., Permutit House, London, W.4.  
*Telephone : CHIswick 6431 Cables : Permutit, London*

# HAYS

## FUEL SAVING APPLIANCES

For over twenty years we have made the following instruments for building up and maintaining the efficiency of all types of fuel burning plant, and the demand for them is at present greater than ever it was.

- (1) HAYS PORTABLE GAS ANALYSERS for (a) CO<sub>2</sub>; (b) CO<sub>2</sub> and oxygen; (c) CO<sub>2</sub>, oxygen and carbon monoxide.
- (2) HAYS COMBINED CO<sub>2</sub> and DRAUGHT RECORDERS.
- (3) HAYS inclined tube DRAUGHT GAUGES, and Portable Vernier Draught Gauges.

*Full particulars from*

**DUGUIDS LTD., LYMM, Nr. WARRINGTON**

## HANDBOOKS · TEXTBOOKS · MANUALS

<b>Boiler House and Power Station Chemistry</b>	15/-
W. Francis, M.Sc.Tech., Ph.D., F.I.C., F.Inst.P. 204 pp. 1941.	12/6
<b>Boiler Feed Water Treatment.</b> F. J. Matthews. 319 pp. 1939.	10/6
<b>Works Boiler Plant.</b> F. J. Matthews. 184 pp. 1940.	20/-
<b>Heating, Ventilating and Air Conditioning Fundamentals</b>	24/-
W. H. Severns 467 pp. 1937.	35/-
<b>Heat Transmission.</b> R. Roysds, M.Sc., M.I.Mech.E. Vol. I: BY RADIATION, CONDUCTION AND CONVECTION. 238 pp. Diagrams. Vol. II: IN BOILERS, CONDENSERS AND EVAPORATORS. 302 pp. each	42/-
<b>The Design of High Pressure Plant and the Properties of Fluids at High Pressures.</b> D. M. Newitt. 491 pp. 1940.	45/-
<b>Industrial Instruments for Measurement and Control</b>	38/-
Types, Applications and Maintenance. T. J. Rhodes. 573 pp. 1942.	4/6
<b>Refractory Materials</b>	24/-
Their Manufacture and Uses. A. B. Searle. 895 pp. 3rd edition. 1940.	25/-
<b>Principles of Chemical Engineering</b>	25/-
W. H. Walker, W. K. Lewis, W. H. McAdams, E. R. Gilliland. 719 pp. 3rd edition. 1937.	25/-
<b>Fuels and Furnaces for Industrial Heating Bibliography</b>	25/-
A Handbook for furnace managers and firemen. H. C. Armstrong. 148 pp. 1938.	25/-
<b>Heat Power.</b> B. Norris and E. Therkelsen. 432 pp. 2nd edition. 1939.	25/-
<b>Modern Practice in Steam Condensing Plants</b>	25/-
A. R. Wright, A.M.I.C.E., A.M.I.M.E. 309 pp.	25/-
<b>Steam Power.</b> W. E. Dalby, F.R.S., M.Inst.C.E., M.I.Mech.E. 769 pp.	25/-
<b>Switchgear for Electric Power Control.</b> E. B. Wedmore, M.I.E.E., F.Inst.P., and H. Trencham, Ass.M.Inst.C.E., A.M.I.E.E. 336 pages.	25/-
<b>Electrical Machinery: Principles, Operation and Management</b>	21/-
Terrell Croft. 4th edition. 394 pages.	19/-
<b>Elements of Steam and Gas Power Engineering</b>	35/-
A. A. Potter and F. Calderwood. 374 pp.	10/-
<b>Power Plant Engineering and Design.</b> F. T. Morse, E.E., N.E. 813 pp.	25/-
<b>Paint Laboratory Note Book.</b> J. Stewart Remington. 2nd edition.	In preparation.
<b>Technology of Solvents.</b> Dr. Otto Jordan; translated by A. Whitehead. 2nd edition.	In preparation.
<b>Emulsifiers and Emulsions. Shoe and Leather Chemicals</b>	In preparation.

*A complete industrial book service is offered. Our industrial bibliography covers, we believe, all the subjects of interest to those engaged in the Process Industries. It has been specially compiled. We can supply, on request, a list of all the books relating to any specific subject.*

**LEONARD HILL LIMITED, 17 Stratford Place, London, W. 1, England**

---

# BOILERS

by

# COCHRAN

have been supplied for all these fuels  
either at Home or Abroad—**THE  
SUCCESSFUL RESULTS** are largely  
due to our long standing policy of  
**PRELIMINARY FUEL TESTING :**

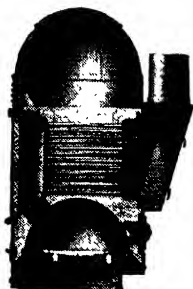

COCHRAN  
VERTICAL  
up to 6000 lbs./hr.

COAL	OIL
COKE	NATURAL GAS
WOOD	PRODUCER GAS
LIGNITE	BLAST FURNACE GAS
PEAT	COKE OVEN GAS
WOOD REFUSE	PULVERISED PITCH
CASHEW SHELLS	SLUDGE GAS
BAGASSE	TOWN GAS
PADDY HUSK	PADDY GAS
COCONUT SHELLS	DIESEL EXHAUST

**E**very  
problem  
carefully  
investigated by

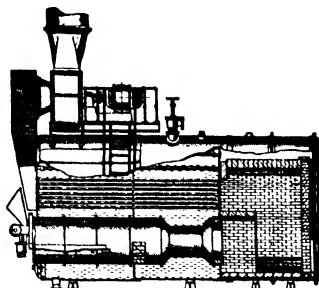

COCHRAN  
SINUFLO ECONOMIC  
6000 lbs. to 30,000 lbs./hr.

**COCHRAN & CO., ANNAN, LTD., ANNAN, SCOTLAND**



# **WIRE ROPE TECHNOLOGY**

---

The manufacture from the Wire Rod to the finished Rope is carried out wholly at the address below, and is entirely under the control of the principals.

Special investigations undertaken, and expert advice given, having in view the maximum economy in the application of Wire Ropes.



## **D. MORGAN REES & SONS LIMITED**

*Manufacturers of Wire and Wire Rope of all kinds*

**WHITCHURCH, CARDIFF**

Telephone No.  
Whitchurch, Cardiff 770-1

Telegraphic Address :  
"NUROPE, Cardiff"

**London Office :**  
**34-35 NORFOLK STREET, LONDON, W.C.2**

# CLARKE, CHAPMAN WATER TUBE BOILERS

The deep experience of years of boiler production is the solid foundation to the success of Clarke, Chapman Watertube Boilers.

Our boilers have been installed in power stations, collieries and industrial plants in all parts of the world, and the satisfaction obtained by their use can be measured by the number of repeat orders and new contracts placed with us.

Our production of Watertube Boilers is summarised in our Catalogue No. 77D, which has been recently revised and brought up-to-date. Profusely illustrated with sectional drawings of Clarke, Chapman installations, this publication is worthy of study by anyone interested in steam generating plant.

We shall be pleased to send you a copy, free and post free, on receipt of your request.

## LA MONT FORCED CIRCULATION BOILERS by Clarke, Chapman & Company, Ltd.

Constructed for any evaporative capacity and with a wide range of pressures, the La Mont Forced Circulation Boiler represents the latest and most flexible form of steam generation.

Complete proposals will be submitted on application.

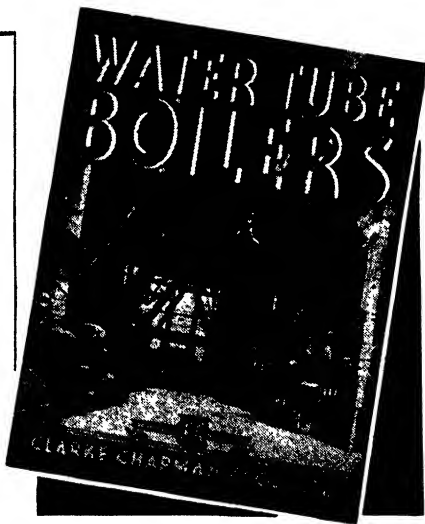

## CLARKE, CHAPMAN & CO. LTD.

Temporary London Office : 29 CASTLEBAR ROAD, EALING, W.5

Telegrams : CYCLOPS. PHONE, LONDON

Telephones : PERIVALE 2254/5

# HOPE EQUIPMENT

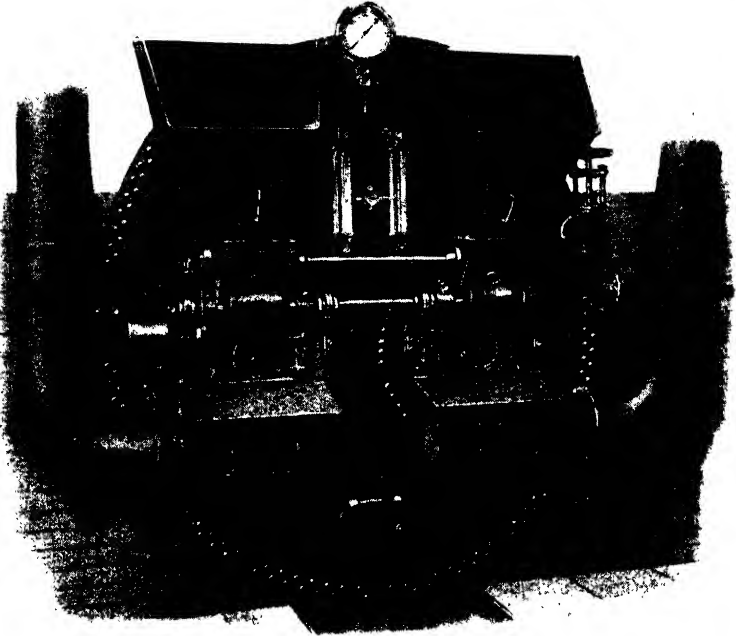

*Automatic Stoker*

ASH HANDLING PLANT. COAL CONVEYORS  
FORCED DRAUGHT FURNACES  
FURNACES FOR SHELL BOILERS  
MECHANICAL STOKERS  
SPECIAL FURNACES FOR LOW GRADE FUELS  
SLURRY BURNING EQUIPMENT

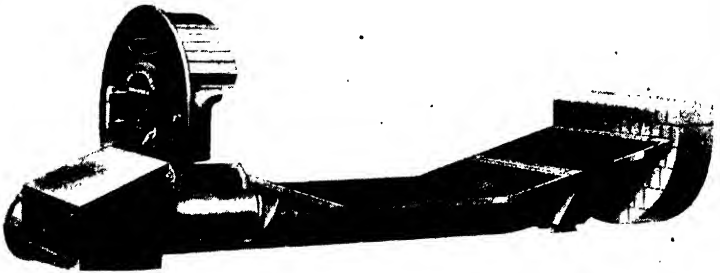

*Special Furnace for Consuming Low Grade Fuels*

CONSULT US ON YOUR FUEL PROBLEMS

**HOPE FURNACES AND ENGINEERING LTD**

'Grams : "Hope, Swansea"

**SWANSEA**

Telephone 5164 (3 lines)

# FUEL EFFICIENCY

is dependent on the  
supply of suitable labora-  
tory testing apparatus

For many years we have specialised in the  
production and supply of such apparatus,  
and in so doing we believe our experience  
to be of some benefit to those applying the  
principles of fuel technology to industry

**We can be of service to you**

**A. GALLENKAMP & Co. Ltd.**

TECHNICO HOUSE, 17/29 SUN STREET  
FINSBURY SQUARE, LONDON, E.C. 2

# PETROLEUM

A MONTHLY TECHNICAL JOURNAL

Annual Subscription: 20s. post free;

22s. 6d., abroad

## SOME RECENT ARTICLES

New Standards for Petroleum Waxes—Producer Gas—Hydrocarbon Waxes—Problems of Power Alcohol—Trinidad Oil—Used Crankcase Oil, Examination—Wax Colloids—Germany's World Oil Plans (several parts)—Surface Energy of Lubricating Oils—Fuel Conversion—Scorched Oil—Theory of Retention—Recovery of Waste Oil: Filtration—Wax Standards Compared—Superfinish—Alternatives to High Octane Petrol—Corrosions of Pipe-lines—Used Oil Recovery—Evolution in the Petroleum Industry—Improving the Efficiency of Lubricating Oils—The Future of Road Transport Fuels—Petroleum Fights the Malaria Scourge—Peat as Fuel—How U.S.A. has Standardised Fuels and Lubricants for Mechanised War—Examination of Emulsions—Conversion of Petroleum Oil-Burning Plants to Coal-Tar Fuels—Natural and Manufactured Gas—A Summary of Petroleum Patents—Town Gas and Producer Gas—The World's Search for Fuel—Fuel from Leaves, or Sawdust—Pitch Fuel: Its Characteristics and Utilization—Conversion of Burners to Creosote Pitch Fuel—Prospects and Problems of Power Alcohol—Liquid Fuel in Steam Generation—Utilization of British Peat, etc., etc.

# CHEMICAL INDUSTRIES

16th Edition (1942), largely re-written and enlarged

350 Qto pp.

15s.

*Published for 11 years under the old title of  
Chemical Engineering and Chemical Catalogue*

*Every chemist, technician, chemical engineer,  
executive—sales or purchasing—should have  
a copy of this valuable encyclopedia ready by  
his side for immediate reference*

## CONTENTS

Constructional Materials for the Chemical Industry—Power Plant and Water Treatment—Chemical Plant Factory Layout—Chemical Plant of Various Types—Air Conditioning—Fire Protection Equipment—Size Reduction—Mixing and Blending—Separating and Grading—Handling, Conveying and Transport of Materials—Instruments and Laboratory Apparatus—Industrial Chemicals—Glossary of Industrial Chemicals and Trade Names—Chemical and Physical Tables—Data of Inorganic Compounds—Fine Chemicals Glossary of Pharmaceuticals and Alkaloids—Glossary of Perfumery Raw Materials—Physical Data of Organic Compounds—Mathematical and Conversion Tables.

## LEONARD HILL LIMITED

17 STRATFORD PLACE, LONDON, ENGLAND



Bennis Stokers not only save fuel but deal efficiently with any class or grade of coal. These machines are burning fuels from the hottest seams of South Yorkshire and Durham to the most inferior fuels available. We

manufacture many types of Mechanical Stoking Apparatus and are in a position to instal the correct machine to meet the requirements and conditions prevailing in each individual plant.

### *Bennis patent Mechanical Stokers*

*Write for publications describing Bennis Equipment. Copies available free on request to*

**BENNIS COMBUSTION LTD.**, Little Hulton, Bolton. London Office: 28, Victoria St., London, S.W.

# INDUSTRIAL CONTROLS LTD.

NORTH ROAD, SOUTHALL, MIDDX.

Phone: SOUTHALL 2680

Engineering Equipment  
 Flow Meters & Controllers  
 Temperature Recorders  
 and Regulators  
 Boiler Load Indicators  
 Feed Water Regulators  
 Control Instruments

*Manufacturers of*  
**DURA-SEAL SEALING PLASTIC**

Unique product for sealing Boiler Settings against infiltration of cold air. Not affected by vibration, contraction and expansion.

Acid and waterproof, WILL NOT CRACK OR PEEL.

One cwt. of DURA-SEAL covers (approximately) 200 sq. ft. at  $\frac{1}{4}$  in. thick. Keeps indefinitely in store.

Used by the largest undertakings.  
**STOP AIR LEAKAGES AND SAVE FUEL.**

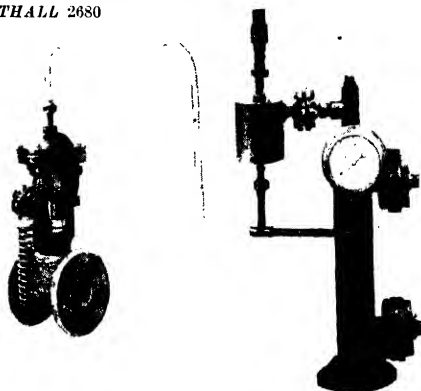

*Automatic boiler feed water regulator for increasing efficiency in the modern boiler house*

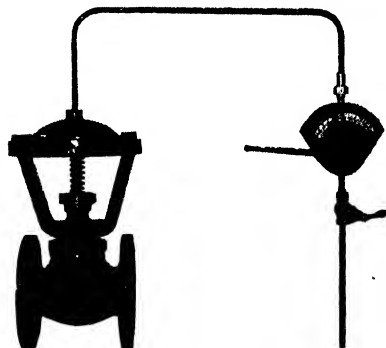

*"Industrial" temperature regulator for controlling temperature of steam-heated air, etc., by automatic adjustment of steam supply, and on tanks, etc., by operating diaphragm valves on steam supply lines*

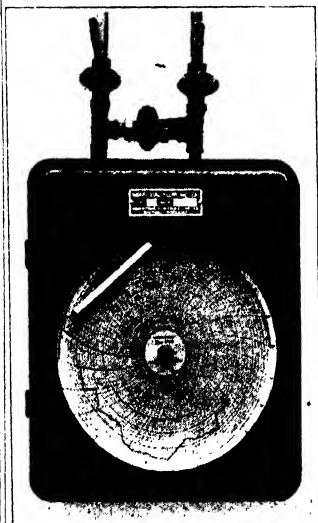

*"Industrial" flow recorder for recording total output of steam from battery of boilers*

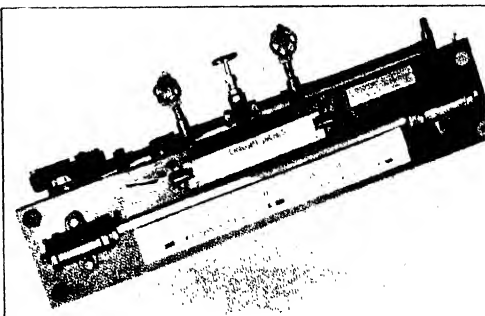

*Boiler load indicator affording instantaneous check on the output of each boiler*







