

BIRLA CENTRAL LIBRARY
PILANI | RAJASTHAN |

Class No. 669

Book No. C 562 N

Accession No. 59178

NEW METHODS FOR SHEET METAL WORK

NEW METHODS FOR SHEET METAL WORK

**A PRACTICAL WORKING TEXTBOOK
For Apprentices, Sheet Metal Workers,
Platers and Draughtsmen Engaged in Air-
craft, Shipbuilding and Other Industries**

BY

W. COOKSON, A.M.I.E.I.

**First-class Finalist (Prize Standard) Metal-plate Work
City and Guilds of London Institute**

Joint-Author "The Elements of Sheet Metal Work".

**LONDON
THE TECHNICAL PRESS LTD.**

1941

669
C 562N
59178
c/66

PREFACE

THROUGHOUT a long experience as a journeyman, instructor, and works manager in the sheet metal trade, the author has found that though the principles of the art of pattern development are often fairly well understood, it is in their application to the practical solution of workshop problems that the average workman finds trouble. This shortcoming, which is usually prominent in ventilation and aircraft work, is mainly due to the fact that most textbooks deal with the subject in an academic manner, and their treatment of many development problems, though adequate enough for the class-room, often fails when used in the factory.

In the present work, based on a series of articles which appeared in the journal, *Sheet Metal Industries*, under the title of "The 'Cookson' System of Triangulation," the author has endeavoured to tackle problems of pattern development from a practical standpoint. The new methods have been used to great advantage in several factories, and many workers in the industry can now take a short-cut to proficiency in laying-out templates.

The author's thanks are due to *Sheet Metal Industries* for permission to use the articles and for the loan of blocks.

FOREWORD

FROM the keen interest taken by sheet metal craftsmen in courses provided by technical schools on pattern development and related subjects, it is evident that this generation and those following intend to maintain a high standard of technical accuracy. Pattern development is not an easy subject to study; it requires a thorough groundwork in mathematics and continual adaptation to special conditions. The method of approach to each individual problem presented in service is therefore of first importance, and for this reason primarily the principles of the Cookson system of triangulation should prove of great service in workshop difficulties. The author has developed his system by practical methods, has rigorously tested his ideas in many applications, and the present writer can vouch for the keen interest taken in the subject both at home and abroad. The craftsman, junior or senior, who masters the simple details of the Cookson system of triangulation has a most serviceable additional tool at his immediate disposal.

ALASTAIR McLEOD,
Editor, "Sheet Metal Industries."

Presented by :—
Shri Motilal Lath
of
MANDRELLA.

CONTENTS

CHAPTER ONE

METHODS OF PATTERN DEVELOPMENT

| | PAGE |
|---|------|
| Parallel-line Development—Pattern for Round Pipe Cut Obliquely—Tee-piece of Equal Diameter—Radial-line Development—Cone Pattern—Method of Triangulation | 1 |

CHAPTER TWO

DESCRIPTION OF LAY-OUT SYSTEM

| | |
|--|----|
| Method of obtaining True Length Lines—Pattern for Trans- former | 11 |
|--|----|

CHAPTER THREE

FURTHER DESCRIPTION OF LAY-OUT SYSTEM

| | |
|---|----|
| Setting-out for Connecting Piece—Tapered T.Obster-back Bend—Cone Frustum Pattern | 19 |
|---|----|

CHAPTER FOUR

JUNCTION PIECES

| | |
|--|----|
| Pattern for Breeches Piece—Multiple Junction Pieces— Pattern for Three-way Junction Piece | 29 |
|--|----|

CHAPTER FIVE

SPECIAL TYPES OF JUNCTION PIECES

| | |
|--|----|
| Flush-sided Breeches Piece—Alternative Lay-out—Flush- sided Breeches with Parallel Ends—Two-way Transition Elbow | 38 |
|--|----|

CHAPTER SIX

SPECIAL TYPES OF JUNCTION PIECES (*contd.*)

| | PAGE |
|---|------|
| Development of Rectangular to Round Two-way Piece— Three-way Junction Piece—Alternative Design for Three- way Piece—Two-way Piece with Unequal Branches | 49 |

CHAPTER SEVEN

CONES INTERSECTING CYLINDERS

| | |
|--|----|
| Conical Branch Connection—Alternative Method—Conical Hopper on Inclined Pipe—An Easier Method of Setting-out | 56 |
|--|----|

CHAPTER EIGHT

CONICAL INTERSECTIONS

| | |
|---|----|
| Use of Cutting-plane Method—Setting-out for Conical Pipe Connections—Pattern for the Main Connecting Piece— An Easier Method of Setting-out | 65 |
|---|----|

CHAPTER NINE

TWISTED AND OFF-SET TRANSFORMERS

| | |
|---|----|
| Fan Outlet Connecting Piece—Obtaining the Transformer Pattern—Twisted Transformer with Top Inclined to a Square Base—Off-centre Transformer | 74 |
|---|----|

CHAPTER TEN

MISCELLANEOUS PROBLEMS

| | |
|---|----|
| Setting-out for Off-centre Shoe—Shoe Fitted to Conical Connecting Piece—Petrol Measure Top—Elliptical Hood Twisted to Outlet Pipe—Rectangular Transition Bend | 85 |
|---|----|

CHAPTER ELEVEN

ALLOWANCES FOR METAL THICKNESS

| | |
|---|----|
| Correct Setting-out for Patterns—Square and Rectangular Work—Bending Allowances—Development of Pipe Clip —Development of Tube Fitting | 93 |
|---|----|

| | |
|-----------------|-----|
| INDEX | 101 |
|-----------------|-----|

NEW METHODS FOR SHEET METAL WORK

Chapter One

METHODS OF PATTERN DEVELOPMENT

THE sheet metal worker who aspires to an all-round knowledge of his craft must of necessity be skilled in the art of drafting patterns from working drawings. It is not sufficient to have a superficial idea of the different methods of pattern cutting and then rely on "rule-of-thumb" methods when a difficult job has to be made. Draughtsmen are too often blamed for what are termed fantastic designs, simply because the average craftsman cannot mark-out the correct patterns for the work.

Simplifications of the designs are then often sought, and the desired modifications are made to the drawings to bring the job within the scope of the workshop. It must be realised, however, that the main duties of the draughtsmen are to give the dimensions and shape of the finished job. They are very little concerned with the surface development of the various parts, unless, perhaps, in a minor way when estimating the approximate sizes of the metal required in making out a material schedule. Particularly in the case of air-duct work, such as transformers and junction pieces, the complaint is often made in the shops that insufficient information is given on the drawings, and that joints, for example, should be more clearly shown by the use of auxiliary projections or similar views.

This means, in effect, that the given orthographic plans and elevations have to be drawn and the required additional views marked-out on the sheet metal by the craftsman. As a large amount of projection work is thus necessary, much valuable time is used. Confusion can also arise through the multiplicity of lines required in the process. Knowledge of pattern development, therefore, to be practical, must be of such a character that jobs can be marked-out as far as is possible directly from the given views on the blue print. To this end, any methods of drafting patterns which involve high labour costs must be discarded and new methods adopted.

Several new and simple methods are described in this work, and by their use the sheet metal worker should be able to tackle difficult drawings sent out from the drawing office and in this way help to raise the technical status of his craft. Even in these days of mass production the skilled template maker and others who can draft patterns correctly are in great demand, for much has yet to be done to make the art of pattern drafting as well known as it should be in the trade.

Too little attention, also, is paid to the necessary adjustments to be made to the pattern for the thickness of metal used, as this must be taken very much into account for accurate light engineering work. It is useless to develop a pattern if, when it is made up, the finished job does not conform to the exact size and shape as specified on the working drawing. In aircraft work, for instance, very fine limits must be adhered to, as these limits are insisted upon through rigid systems of inspection.

The days of the "hammer and chisel" are long past, and a good knowledge of mathematics is as necessary to the modern craftsman as to the people who draw the plans. A knowledge of the geometrical development of surfaces calls for some grounding in the principles of the different methods of drafting patterns in general use. There are three methods, of which the first is the development by parallel lines of patterns for articles shaped in the form of prisms and cylinders. The second is the radial-line method, used for obtaining the

patterns for conical objects, and the third is the method of triangulation.

Of these three general methods the parallel-line and triangulation methods are the most widely used. The radial-line method is not applied as much as formerly, because, with the exception of the right cone and its frustums, all work of a conical nature is best tackled by the triangulation method.

In this work only a brief description and a few typical examples of parallel-line and radial-line development are given, as these present nothing new and are more fully dealt with elsewhere. The triangulation system described, however, is different from the methods hitherto in use in the trade. As the great merit of triangulation is its adaptability to the development of the majority of patterns, its use cannot be too highly stressed as a means of tackling most problems which may confront the craftsman in his daily tasks.

PARALLEL-LINE DEVELOPMENT

This method can be applied to the development of the patterns for elbows and tee-pieces for air-duct and similar work. The underlying principle of the system can be seen by studying the illustration shown in Fig. 1. This depicts the perspective view of a round pipe, with one end cut on the slant, placed on a horizontal plane. Drawn on its surface are a series of equally spaced parallel lines. An elevation of the pipe is shown projected on to an adjacent vertical plane; the edge lines of the elevation are lettered and numbered A-0 and G-6 respectively.

The parallel lines on the elevation surface are the same length as those on the pipe, but they are not equally spaced. If the job were cut at the seam 0-A and the metal "unrolled," we should obtain the pattern as it would appear on the flat sheet, as shown in Fig. 2 (b). Thus, if we first draw an elevation of the pipe as in Fig. 2, and draw parallel lines on its surface similar to those on the elevation in the perspective view, we can set-out a pattern by reproducing the parallel lines in their correct relation to each other and cutting them off in lengths similar to the appropriate elevation lines.

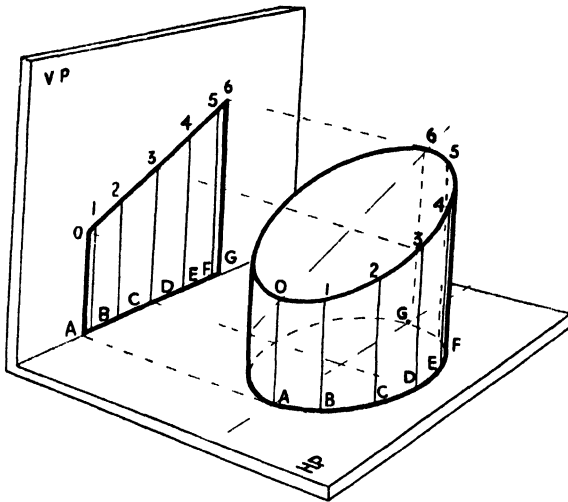

FIG. 1.

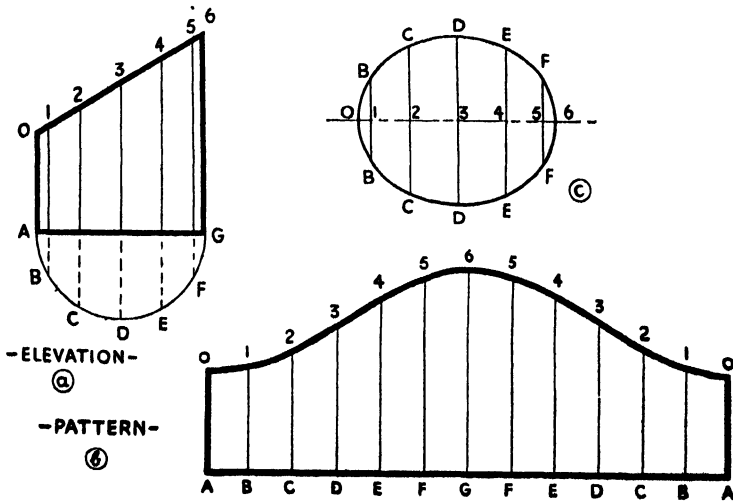

FIG. 2.

PATTERN FOR ROUND PIPE CUT OBLIQUELY

The following procedure should be used to develop the pattern on sheet metal. First draw the elevation 0-A-G-6, as at Fig. 2 (a), and on the base edge describe a semicircle to represent a half-section of the base. Divide the semicircle into six equal parts, letter the points B, C, D, E, and F, and draw vertical lines from them to meet the top edge line 0-6. These lines are shown dotted to the base line. Next draw a horizontal line of indefinite length for the base or stretch-out line of the pattern, mark a point A and measure off from it the circumference of the pipe. This distance A-A is obtained by multiplying the pipe diameter by $3\frac{1}{2}$. Divide A-A into twelve equal parts and erect perpendiculars of indefinite length from the points. Cut these lines off equal in length to the similar full lines on the elevation surface, line 2-C, for example, in the pattern, being the same length as line 2-C (the full line between the top and base edges) in the elevation. Finally, draw a smooth curve between the top points to complete the pattern.

The shape of the top section as at Fig. 2 (c) is found in the following manner. Draw a horizontal line in a convenient position, mark a point 0 and measure off distances 0-1, 1-2, 2-3, 3-4, 4-5, and 5-6 from the elevation top edge. Draw perpendiculars of indefinite length through the points, and cut them off each side of 0-6 equal in length to the "ordinates," *i.e.*, the dotted lines drawn from points B, C, D, E, and F to the base line, in the elevation. Through all the points found draw a smooth curve.

PATTERN FOR TEE-PIECE OF EQUAL DIAMETER

The example shown in Fig. 3 is of a cylindrical tee-piece made of equal diameter pipes. To obtain the patterns for the job, first draw an elevation as shown and describe a quadrant on the base line. Divide it into three equal parts, A-B, B-C, and C-D, and draw perpendiculars to the base line from the points. These lines are shown dotted. Next produce the lines to meet the joint line between the pipes at points 1, 2, and 3. Draw a horizontal line of indefinite

6 NEW METHODS FOR SHEET METAL WORK

length in a suitable position and mark a point A. Calculate the circumference of the cylinder and measure it along the stretch-out line. Divide A-A into twelve equal parts and erect perpendiculars of indefinite length from the points.

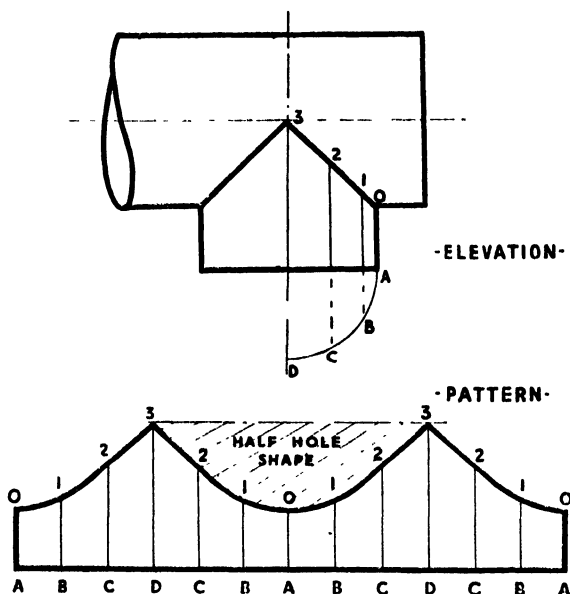

FIG. 3.

Letter these as shown. Cut the perpendiculars off equal in length to the similarly marked lines in the elevation and draw a smooth curve through the points found. The shaded portion of the pattern represents half of the shape of the hole in the main pipe.

RADIAL-LINE DEVELOPMENT

The radial-line method of pattern development is used for those objects, such as cones and pyramids, the sides of which converge to an apex. By far the most common object which requires marking out in the workshop is the right cone frustum. The method of drafting the pattern consists in

using the slanting edge line of the full cone as a generator and describing a girth line which is made equal in length to the circumference of the cone base. Each of the free ends of the girth line are joined by straight lines to the cone apex, and from the same point the top edge curve of the frustum is drawn across the pattern. Many jobs, such as breeches pieces, can often be made up of portions of right or oblique cones, but unless the parts are of short taper the best plan is to obtain their patterns by triangulation.

CONE PATTERN

In Fig. 4 is shown the method of drafting the pattern for a right cone frustum. Draw an elevation of the frustum as

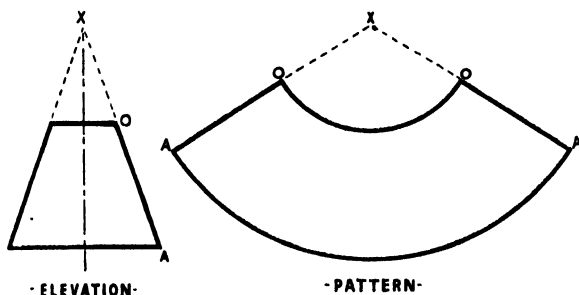

FIG. 4.

shown and produce the edge lines to an apex, marked X. For the pattern mark a point X in a suitable position, and with radius A-X from the elevation describe an arc of indefinite length. Mark a point A and measure the circumference of the cone base round the arc, preferably with a flexible steel rule. Join the points to X. Next take radius O-X from the elevation and transfer to the pattern as shown.

Fig. 5 illustrates another method generally used to obtain the length of the girth line. Describe a semicircle on the cone base line A-G and divide it into six equal parts, A-B, B-C, etc. Take one of these spacings and step it round the

girth line twelve times. Join the end points to X and complete the pattern as for the previous example.

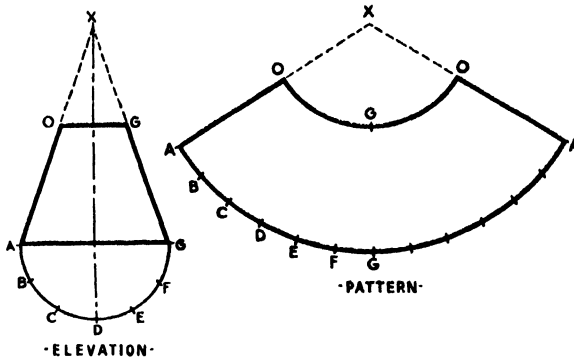

FIG. 5.

METHOD OF TRIANGULATION

The triangulation method is universally applied in the trade to solve a large number of development problems. In the main the standard system consists in drawing an elevation and plan of the object to be developed, dividing the surface of the plan into a suitable number of triangles, finding the true lengths of the triangle sides, and building up pattern triangles in the correct relation to the triangles already drawn in the plan. A plan of the object, that is, a view which shows the top or bottom edges of the material, is essential to this system.

Most working drawings give the front elevation, side elevation ("end view"), and the plan of the job. When triangulating the plan it is usually necessary to set-out this from the elevation, and in those cases where the top and base of the article to be developed do not lie between parallel planes, problems of projection are certain to arise. When an object, such as a ventilation transformer, has a top inclined at an angle to the base it becomes vital to draw a correctly projected plan from its elevation, which procedure calls for a fairly good knowledge of the principles of geometry.

Also, if the ends of any object are curved or undulating, as, for instance, the joint line formed by the intersection of two right cones, the projection of an accurate plan becomes a difficult proposition. Most workmen have experienced this trouble, particularly when jobs are of slight taper. The radial-line method of developing cannot then be used, as this system is only possible if an apex can be found. What usually happens in practice is that such patterns are made somewhere near to the desired shape by roughing-out methods and trimmed to size where necessary. This is a very unsatisfactory way of working and an alternative method is sometimes used, consisting of making models of the job and obtaining the dimensions of the pattern from them. Errors easily creep in by this method, and, as a rule, it takes too much time to be a practical proposition.

Because of this difficulty of developing satisfactory patterns the designing of much new work is restricted. In air-duct work, for example, there is great scope for the introduction of more efficient breeches pieces, transformers, etc., provided they can be made correctly in a reasonable time. To obviate most of these difficulties a new triangulation system, now to be described, was evolved. It is designed to meet the demands of the workman who requires an efficient method of pattern development which is simple in operation and easy to apply to any triangulation problem he is likely to encounter in everyday practice. In this system the projection of a plan from the elevation of the object is unnecessary, as all the true lengths are obtained directly from the elevation or end view, drawn in a right position.

Once the principle of the system is understood it is easily memorised ; in fact, if the few simple rules are strictly adhered to, a workman with the most elementary knowledge of geometry is able to mark-out patterns which he would have been unable to tackle by other methods. The developing of patterns for many jobs which involve interpenetration of surfaces are also brought within his capabilities, as such problems can often be more or less eliminated if desired. This is done by drawing an approximate joint line between the

components of the job and the patterns triangulated, a correct fit between the respective parts when assembled being guaranteed. Other advantages of the system, apart from its simplicity of operation, are that a minimum of lines are used, and, as there are no plan lengths to cross over each other, the possibilities of errors are reduced and the laying out of the pattern on the sheet metal is straightforward and logical.

Chapter Two

DESCRIPTION OF LAY-OUT SYSTEM

THE following description of the system is intended to show the principle as clearly as possible, and at its conclusion a few simple rules will be given to enable the student to use the system in actual practice. To triangulate the pattern for an article, it is first of all necessary to draw its elevation in a right position. The surface of the elevation is then divided up into a convenient number of triangles by means of "false" length lines, and their true lengths

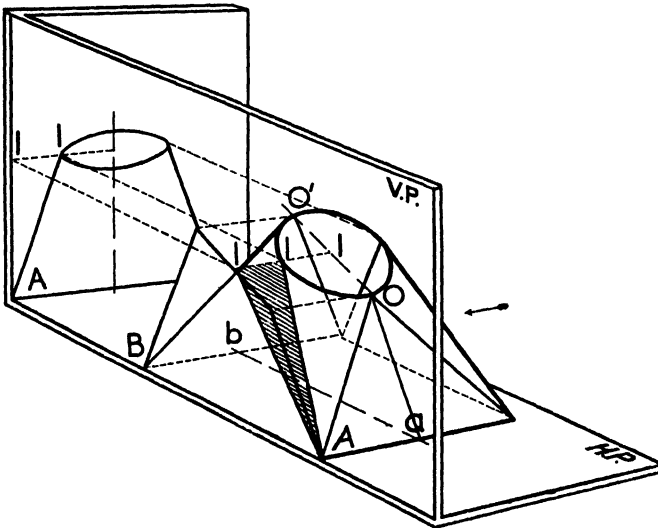

FIG. 6.

determined, to enable the pattern triangles to be built up. The method of obtaining these true lengths is illustrated in Fig. 6, which shows a pictorial view of a ventilation trans-

former, the round top of which is inclined to its square base. It is placed on a horizontal plane with one edge of its base touching the vertical plane, which must be assumed to be transparent to enable the elevation to be seen drawn upon it. The elevation view is projected from the outline of the transformer looking in the direction of the horizontal arrow, whilst the end view is projected as shown.

On the surface of the transformer is drawn the true length 1-A between the points 1 and A. This line is projected on to the elevation and end view, and as it is inclined to both planes it appears in the elevation and end view as a false length. Thus an elevation or end view of the transformer on a blue print would only show 1-A as a false length. If line 1-A be closely observed on the transformer it will be seen that it forms the hypotenuse of a right-angled triangle (shown shaded), the elevation or false length making the opposite side, the third side being the length of the projector 1-1, which connects the top edge of the transformer and the vertical plane. From this it should be obvious that, given the elevation length, the true length is determined by the length of the projector in any right-angled triangle. The projector line is, of course, always at right angles to the vertical plane. It can be seen from the end view that the length of the projector is the difference in length between the centre line of the transformer top and the vertical plane—which is actually the half-width of the base—and the half-width of the top.

The above principle, which the pictorial view should have now made clear, is applied in practice in the following manner. A drawing of the job is shown in Fig. 7, the false length line 1-A being drawn in the elevation. The position of 1-A is determined by describing a semicircle, representing a half-view of the top circular face, on the top edge line, and drawing an ordinate from the semicircle to the edge line, marking it 1-1. The end view has a line A-A drawn parallel to its centre line; this line represents the edge view of the vertical plane and the line between it and the centre of the transformer top is clearly shown. A triangle 1-A-1 is thus formed between

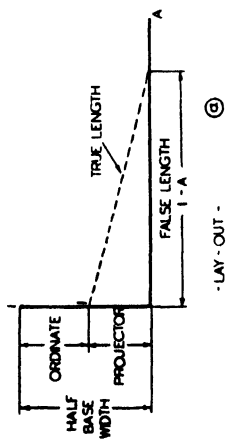
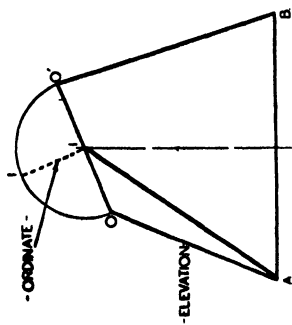
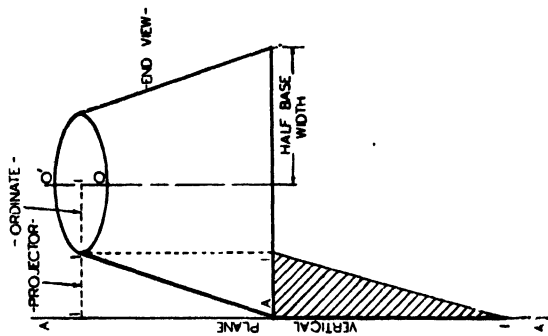

Fig. 7.

the vertical plane and the transformer and is the end view of the shaded triangle in the pictorial view. To make this triangle its true length, point 1 on the top edge is projected down to the base line marking 1 and the elevation false length 1-A extended along A-A from the corner of the base, also marking 1. This point is joined to 1 on the base line, thus obtaining the true length of 1-A and completing the triangle.

The true lengths of all elevation lines are obtained on this principle by the use of a lay-out, which is the basis of this system of triangulation. To construct the lay-out, a vertical line of indefinite length is drawn in any convenient position, Fig. 7 (a), and a point marked on it. Number this point 1, to denote the centre of the top of the job. The half-width of the base is next measured off from 1 and an indefinite horizontal line drawn from the point found. From 1 is also marked off the length of the ordinate 1-1 from the elevation. The distance between this point and the corner of the right angle formed is the projector length. The false length 1-A from the elevation is marked off along the horizontal line from the corner of the angle, and the point marked is joined to the nearest point 1 on the "perpendicular," thus obtaining the true length required.

It is not necessary to repeat all this construction of the lay-out for each false length line from the elevation, as it is quite correct to use the same right angle for any number of lines. To do this, adopt the following procedure for the lay-out when triangulating the patterns for any articles of which the bases are square or rectangular :—

1. Draw a vertical line and mark off on it a point to denote a top centre line of the object.
2. From this point measure down the top ordinates or half-widths and number the points.
3. From the same point measure down the half-width of the base and draw a line of indefinite length from the point found, at right angles to the vertical line.
4. Step off, from the corner of the angle formed, the elevation false length lines along the horizontal line.

5. Join the points marked off on the horizontal line to the numbered points on the perpendicular in the correct order, so obtaining the true lengths of the distances measured on the horizontal line.

The pattern triangles are then built up with the true lengths in a manner to be explained later.

PATTERN FOR TRANSFORMER

From this explanation of the system there should be little difficulty in applying it to the development of the transformer pattern, using the elevation only. It is only necessary to develop a half-pattern for the transformer, as the drawing shows that each half is symmetrical about the end view centre line. The full pattern can be drawn as desired.

Draw the elevation as in Fig. 8, lettering the base corners *Aa* and *Bb*. On the edge line 0-6 describe a semicircle, divide it up into six equal parts, and draw perpendiculars to 0-6. Number each ordinate 1, 2, 3, 4, and 5 respectively. Connect the points on 0-6 to the base corners *Aa* and *Bb* with full lines, 1, 2, and 3 to *Aa* and 3, 4, and 5 to *Bb*. The elevation surface is thus divided up into triangles, each connecting line between the top and base edges being a "false" length. Each of the full lines is designated by its appropriate ordinate number, line 2-A, for instance, in Fig. 8 being the distance between the base point of ordinate 2 on the top edge 0-6 and the corner point *Aa*. The edge lines of the elevation 0-*Aa* and 6-*Bb* are both true and false lengths. This will be made clear by reference to the pictorial view in Fig. 6. Consider the line 0-*a* on the transformer. This line is parallel to the vertical plane, therefore it appears as a true edge line in the elevation. At the same time the edge line is also the projected or false length of 0-A on the transformer. This is the reason the edge lines in the elevation are lettered *Aa* and *Bb* at the base corners (Fig. 8).

The lay-out is next drawn in a convenient position. In accordance with the rules previously set out, a vertical line is drawn, point 0 and 6 marked on it, and the ordinate lengths.

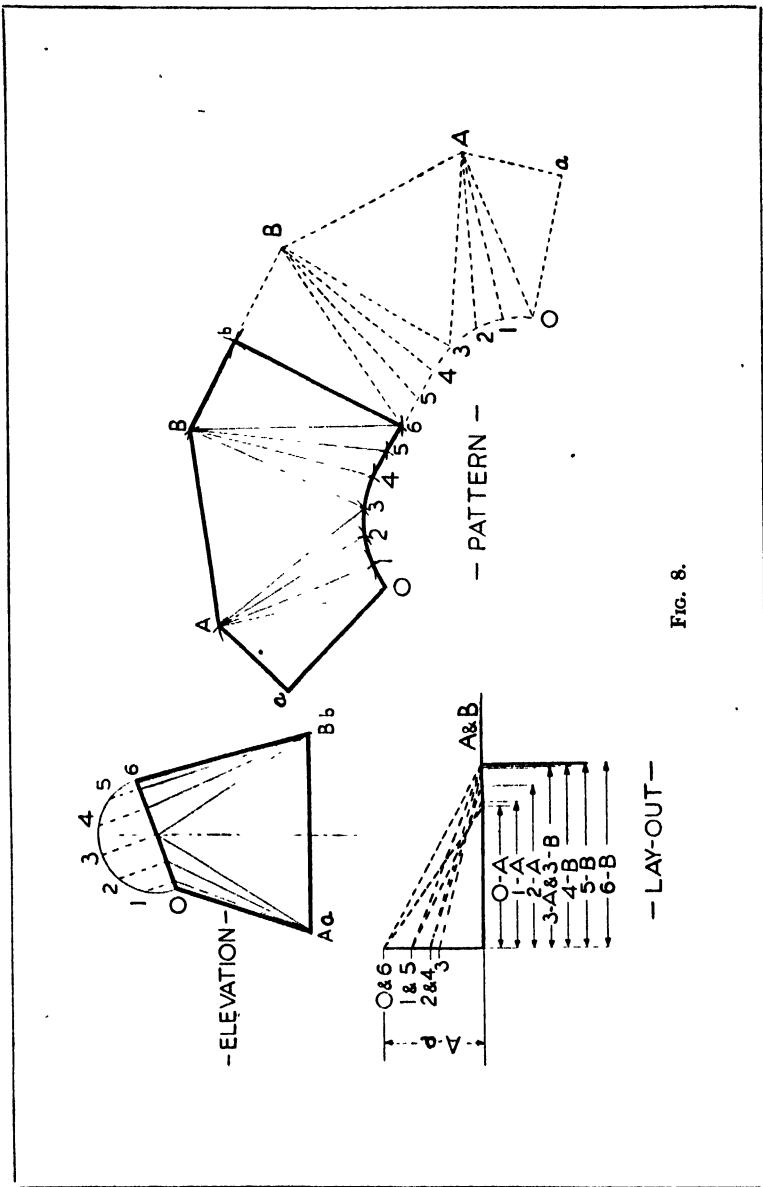

Fig. 8.

measured off from 0 and 6 and numbered as shown. Each point, it will be noted, has two numbers, because the lengths of 1 and 2 ordinates are the same as 5 and 4 respectively. The half-width of the square base is next measured off from point 0 and 6 and a line drawn at right angles to the perpendicular and lettered A and B for each corner.

To start the half-pattern, draw in a suitable position the edge line of the elevation and mark it 0-*a*. Next mark off the same line along the horizontal line of the lay-out and join the point marked to 0 on the perpendicular. With this true length describe an arc from 0 on the pattern lay-out to the right of *a*. Take the half-base width A-*a* and, using *a* as centre, cut the arc previously drawn, at A. Join *a* to A and 0 to A to complete the first pattern triangle. It is very important to note that the number of the false length line determines to which point it is connected on the lay-out perpendicular, 0-A joining to 0, 1-A joining to 1, and so on. The best method is to pick up a line, 0-A for instance, with the dividers, mark it off on the horizontal of the lay-out, keep one point of the dividers on the point marked and open the dividers to place the other point on the correct number on the perpendicular, which is 0.

To continue the development, take the false length 1-A from the elevation—the full line—measure it along the base line of the lay-out, and from the point marked extend the dividers to point 1 on the perpendicular. With this true length describe an arc to the right of 0 in the pattern lay-out, using A as centre. Cut this arc with spacing 0-1 from the semicircle in the elevation, using 0 as centre.

Next take distance 2-A from the elevation, measure it off on the lay-out base line and extend to point 2 on the perpendicular. Describe an arc with the true length from A in the half-pattern and cut this in 2 with spacing 1-2 from centre 1. Take false length 3-A, obtain its true length in the lay-out, and cut an arc from centre A in the half-pattern in 3, with spacing 2-3.

The next line, 3-B, is the same length as 3-A, so strike an arc from 3 with this distance and cut it in B with the true

base length $Aa-Bb$ from the elevation. Join A-B. Take false length 4-B next and measure it along the lay-out base line. Triangulate to 4 on the perpendicular and strike an arc from B in the half pattern. Cut this arc in 4 with spacing 3-4, using 3 as centre.

Take false length 5-B, measure off and triangulate in the lay-out, and with the true length describe an arc from B and cut it in 5 with spacing 4-5. Take the edge line 6-B*b*, triangulate in the lay-out, and swing an arc from B in the half-pattern with the true length. Cut this in 6 with spacing 5-6 from centre 5. Finally, take the edge line as a true length from the elevation and with it describe an arc from 6, then cut this arc in *b* with B-*b*, which being the half-width of the base is equal to A-*a*. Join B to *b*, and *b* to 6.

Draw a smooth curve through the top points on the half-pattern. To complete the full pattern it is necessary to reproduce the lines already drawn. This is done by first picking up line 6-B in the half-pattern, swinging an arc from 6 to the right of the edge line 6-*b*, and cutting it in B with the half-base width B-*b* from centre *b*. From B an arc is struck to the right of 6-*b* with distance 5-B, and it is cut in 5 with spacing 5-6. Continue the development in this manner; taking each line in turn from the half-pattern will enable the whole job to be set-out in a very short space of time.

The student would be well advised to go over the foregoing explanation very carefully with a pair of dividers in hand and check up the description of the development with the lines shown in the diagram. In this way he will become familiar with the principle of the system; and he can then proceed to draft the pattern on paper. It is a good plan to cut out the finished development after allowing a small overlap on one of the edge lines to enable the joint to be gummed together when the model is shaped up. With practice the student should soon be able to use the system in the workshop, marking out the job on sheet metal, and in this way gaining sufficient confidence to tackle any of the jobs to be described later in this work.

Chapter Three.

FURTHER DESCRIPTION OF LAY-OUT SYSTEM

THE new triangulation system is easily applied to the development of patterns for articles which have square or rectangular bases, but, of course, there are innumerable jobs which differ from these conditions. It must be clearly understood that the shape and contour of the ends, faces or sections of any article to be triangulated, or the angle at which they lie to each other, do not in the least affect the use of the lay-out system. Once the elevation or end view of an object is drawn and the correct shape of its top and bottom faces determined, it becomes merely a routine matter of triangulating the surface of the elevation and deriving the true lengths on the lay-out. In this way all the difficulties of triangulation disappear, because there are no plan lengths with which to contend.

Practically all jobs can be triangulated from the elevation as drawn on a working drawing or blue print, as it is unnecessary to draw other elevation or plan views to enable true sections to be obtained in their correct relation to each other. If the projected plan of an object can be simply drawn as, for instance, two concentric circles representing the frustum of a right cone, its pattern can be obtained by the usual methods of triangulation if desired ; but if a plan is required that calls for much projection work from the elevation, the lay-out system should be used.

To triangulate the pattern for a ventilating connecting piece, as shown in the three views of it in Fig. 9, it is necessary to understand certain modifications to the lay-out to suit the altered conditions from those previously described. It will be seen that the job has a circular top inclined to a circular

base of larger area, both being symmetrical on a common centre line. In the elevation, plan, and end view, is drawn a false length line 1-B, the position of which is determined by the ordinates 1 and B on the top and base of the elevation.

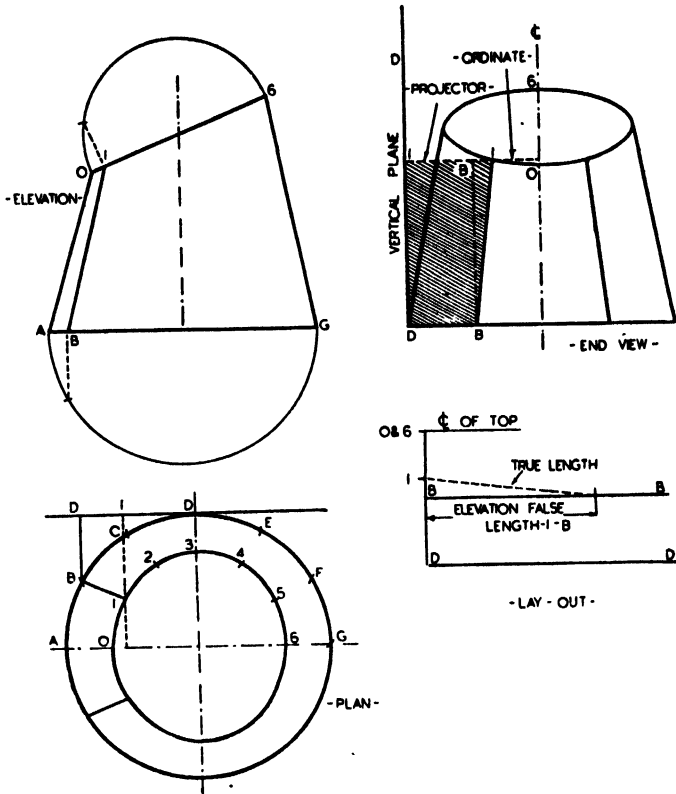

FIG. 9.

The principle of obtaining its true length from the elevation is as follows :—

An edge view of a vertical plane D-D is shown in the end view. The false length 1-B is projected to the vertical plane from point 1 on the top edge of the job and from B to D on the base line. This means that there are two pro-

jector lines, 1-1 and B-D. Instead of the triangle as formed in the end view in Fig. 7, there is now a trapezoid 1-1-B-D. If, however, point B is projected up to 1-1, marking B, a triangle B-B-1 is formed. The distance from B to 1 on the top edge is thus the difference in the lengths of the two projectors 1-1 and B-D.

This procedure gives a method of drawing a lay-out to obtain the true length of 1-B. Draw a vertical line as shown and mark a point 0 and 6 on it to represent the centre line of the top. Measure down from this point the half-diameter of the base and mark the point D. Also from 0 and 6 measure the same distance as between B and the centre line of the end view, which is actually the base ordinate B in the elevation. Mark this point on the perpendicular B. Draw lines of indefinite length from 0 and 6, B and D at right angles to the perpendicular. Next measure on the perpendicular from 0 and 6 the top ordinate 1, and mark the point accordingly. Take the elevation false length 1-B and mark it off from B on the lay-out along the horizontal line, and from the point marked join a line to 1 on the perpendicular to obtain the true length. In this manner there is reproduced the triangle B-B-1 in the end view elongated to the length of 1-B in the elevation. It should now be obvious that the deciding factor in determining a true length is *the difference in the lengths of the projectors* between points on the edges of the object and a vertical plane contiguous to it. This is the principle of the lay-out, in which the projector lengths are fixed between a location point derived from the top of the object and a base line representing the position of the vertical plane.

In actual practice the lay-out is drawn as follows :—

1. Draw a vertical line and mark off on it a point to denote a top centre line of the object.
2. From this point measure down the top ordinates or half-widths and *number* the points.
3. From the same point measure down the half-base widths or ordinates and from each point draw a

line of indefinite length at right angles to the vertical line, marking its appropriate *letter* on each line.

4. Step off each false length on the horizontal line marked with the same letter, measuring from the corner of the angle formed by the vertical and horizontal lines.
5. Join the points marked off to the appropriate *numbered* points on the perpendicular, so obtaining the true lengths required.

SETTING-OUT FOR CONNECTING PIECE

By following the above rules the student should now be able to develop the pattern for the connecting piece as shown

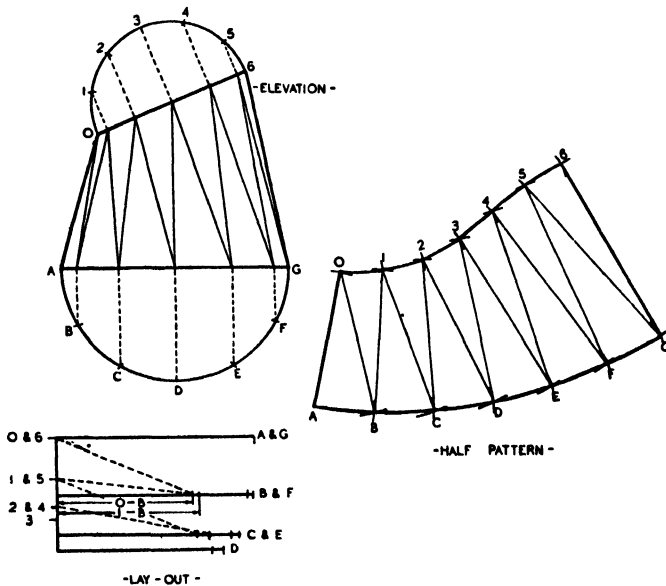

FIG. 10.

in Figs. 9 and 10. Draw the elevation 0-6-G-A, and describe a semicircle, representing the half-surface of the top, on 0-6,

divide into six equal parts and number 1, 2, 3, 4, and 5, as shown. Next draw perpendiculars to the top edge, so obtaining the ordinates for the lay-out. On A-G describe a semi-circle which is half the outline of the base and divide it into six equal parts, marking the points B, C, D, E, and F. Draw in the ordinates to the base edge A-G and join up all the points as shown, thus dividing the surface of the elevation into triangles.

The lay-out is next drawn in a suitable position, the top ordinate points being measured off from 0 and 6 and numbered 1 and 5, 2 and 4 and 3. From the same point is marked off the base ordinates and parallel lines drawn from the points, marked with the appropriate letters from the base semicircle.

It is only necessary to draft a half-pattern, because both halves of the job are the same each side of the horizontal centre line in plan. Start by drawing in a suitable position the edge line of the elevation 0-A. Next take the false length 0-B, mark it off on B line on the lay-out and join the point marked to 0 on the perpendicular. With this true length describe an arc from 0 on the line 0-A to the right of A. Take the distance A-B from the base semicircle, and, with A as centre, cut the arc previously drawn in B. Next pick up the false length 1-B, mark off on B line on the lay-out, join to 1, and with this true length describe an arc from B in the pattern lay-out. Cut this arc from 0 with distance 0-1 from the semicircle on the top edge, so obtaining point 1.

The false length 1-C is next placed on C line on the lay-out, and the point marked joined to 1. This length is then added in the same manner as the others to the half-pattern. The remainder of the triangles are dealt with in similar fashion until the half-pattern is complete. Join all the points on the top and base of the pattern with a smooth curve after reproducing the triangles for the full pattern.

TAPERED LOBSTER-BACK BEND

A problem which can be very easily solved by the lay-out system is that of the tapered lobster-back bend. In this job each of the segments are circular ended, the segments tapering gradually from a large to a smaller diameter pipe.

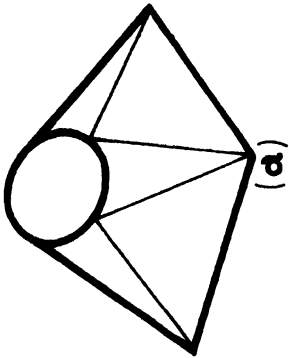

(a)

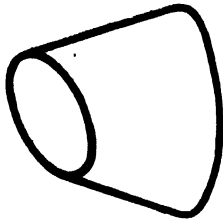

(b)

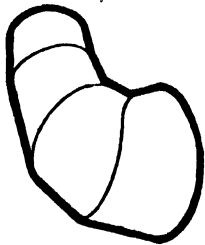

(c)

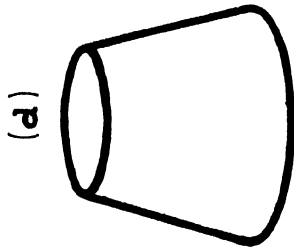

(d)

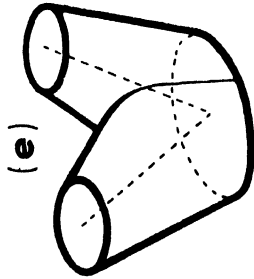

(e)

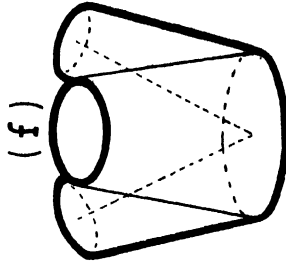

(f)

(a) Square to round Transformer, p. 13.

(b) Connecting Piece, p. 20.

(c) Tapered Lobster-back Bend, p. 26.

(d) Cone Frustum, p. 27.

(e) Breches Piece, p. 32.

(f) Three-way Junction Piece, p. 36.

As a rule the joints between the segments are butted together and welded, so there is no necessity to make metal thickness allowances for slip-in joints, the circumference of the small end of the first segment being exactly the same as the large end of the next segment, and so on. An elevation of the lobster-back is shown in Fig. 11, the base-edge line A-G being the diameter of the large pipe and Y-Z the diameter of the reduced end. The elevation is divided up into the number of segments required, and the patterns for each one have to be got out separately, the method being, however, the same in each case.

To develop the half-pattern for the first segment A-0-6-G, it is essential to divide it up into a convenient number of triangles and find their true lengths on the lay-out. Draw a semicircle on A-G, as shown, to represent half the circumference of the large end of the segment. Divide the semicircle up into six equal parts, number B, C, D, E, and F, and draw perpendiculars (shown dotted) to the base line A-G. Next draw a semicircle on 0-6, divide this also into six equal parts, and draw perpendiculars to the top-edge line. Join all the points with false length lines to obtain the elevation triangles.

The lay-out is next drawn according to the rules previously set out. On the perpendicular a point is marked 0 and 6, and the top ordinates marked from it and numbered. The bottom ordinates are measured off from the same point, horizontal lines drawn and lettered the same as those on the base semicircle. The true lengths of the elevation triangles are found on the lay-out similar to the previous example, and the half-pattern developed in the same way.

It will readily be seen that the next segment has for its *base* line the distance 0-6, and the surface of it can be divided up into triangles by drawing a semicircle on its top edge, placing in the ordinates and joining the points to the points on 0-6. To save confusion with the lay-out for this segment delete the numbers on the ordinates on 0-6 and mark them *b, c, d, e, and f*, as shown. Construct the lay-out in the usual manner and develop the pattern triangles from it. The remaining segments are dealt with similarly. By these means

the patterns for the whole job can be quickly and accurately drawn, as the bugbear of projecting the plan of each segment with the consequent confusion of the plan length lines, particularly in the segment throats, is entirely eliminated. In addition, all the spacings for the circumferential joints are obviously taken from the elevation, and therefore the possibility of errors, by using their elliptical plan outlines, cannot arise.

CONE FRUSTUM PATTERN

One of the most common objects which requires to be set-out is the pattern for a frustum of a right cone. In Fig. 12 is shown an elevation of such a job, the pattern for which is

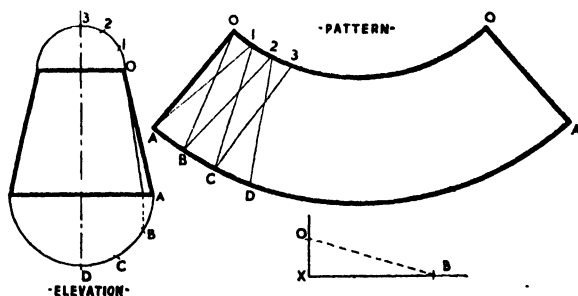

FIG. 12.

drafted as follows. First set-out the elevation and describe a semicircle on the top-edge line. Divide this up into equal parts, 0, 1, 2, 3, etc. Next describe a semicircle on the base edge and draw an ordinate from point B to the edge line. Join the point on the base edge to 0 with a false length line.

Draw two lines of indefinite length mutually perpendicular to each other for a lay-out. Cut the vertical line 0-X off equal in length to ordinate B in the elevation. Take the false length 0-B, measure it off on the lay-out base line from the corner of the angle. From the point found join a line to 0 on the perpendicular to obtain the true length line for the pattern development.

Start the pattern by drawing in a suitable position a line equal in length to the edge line 0-A in the elevation. This is

the seam line for the pattern. Next pick up with the dividers the true length 0-B from the lay-out. Describe an arc from 0 on the seam with this true length and cut it in B with spacing A-B from the semicircle, using A as centre. From A in the pattern lay-out describe an arc with the same true length line and cut this in 1 with spacing 0-1 from the elevation top edge. From point 1 describe an arc to the right of B with the true length line. Cut this arc in C with the spacing B-C. Next, from point B, swing an arc with the true length and cut it in 2 with spacing 1-2.

Continue the development on the same lines throughout until the full pattern is complete. One method by means of which the pattern can be quickly and neatly drafted is to use three pairs of dividers. Set one pair to the length of the true line and the other pairs to the length of a top edge and bottom edge spacing respectively, and pick them up in turn as required.

Chapter Four

JUNCTION PIECES

PERHAPS the most interesting of the many problems met with in air-duct and dust-extraction work are those which are concerned with the development of patterns for breeches and multiple-way junction pieces. These jobs are made in a number of different ways, depending on the particular design of the plant, the most common type having two or three circular-ended branches converging into a round main.

Breeches pieces are designed to distribute or converge the air flow with as little friction as possible. It is often advocated that these jobs should be made up of portions of oblique cones to facilitate the drafting of their patterns by the radial-line method. This method has certain disadvantages, the chief of which is that if the inlets are a good distance apart in proportion to the depth of the job the cross-section area of the branches is reduced.

To obviate this the throat of the job is made fairly high from the base, to give as much area as possible between the joint face and the branches. The joint face is best made semi-elliptical, to keep the shape of the branches the correct area and to give a pleasing appearance. This design necessitates the use of triangulation to obtain the patterns, and the lay-out system is particularly suitable for setting-out this class of work because it is unnecessary to determine the geometrical solid of which the branches are made up, as their surfaces are triangulated between suitably shaped end and joint faces.

An end view or elevation of the job used in conjunction with a lay-out are all that need to be drawn to obtain the true length lines for the pattern triangles. True length lines

are obtained without the use of a projected plan in every case. It is not necessary to find the exact position of a joint line between the branches of a junction piece by determining points on their surface interpenetrations, as a suitable joint line can be drawn, within certain limits, to a desired contour. Each of the branches is then triangulated to the shape drawn, so ensuring the same length of joint line for each part. This procedure eliminates a good deal of the geometrical construction that is required when developing multiple-way piece patterns, particularly when the branches vary in size and shape.

The simplest type of breeches piece has branches similar in shape, as they transform from circular inlets to a circle, the area of which is equal to the combined areas of the inlets.

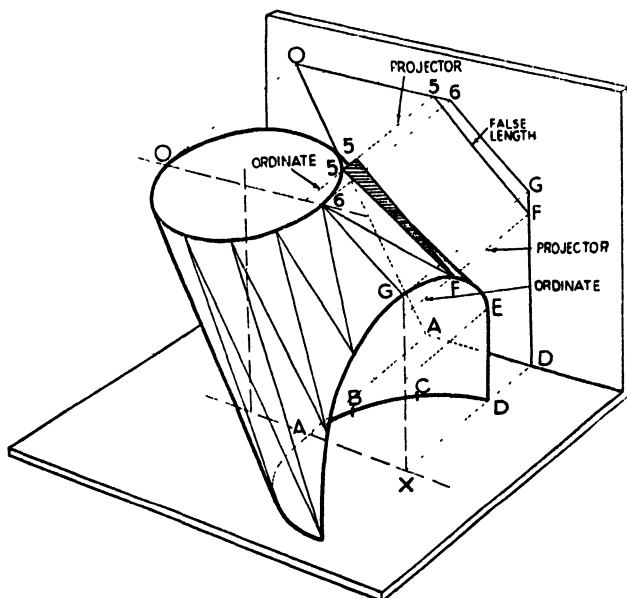

FIG. 13.

Fig. 13 shows a perspective view of one branch of this type of breeches, placed on a horizontal plane. On the vertical plane is depicted an elevation as projected from the outline

of the object. The face of the joint cut between the two branches is clearly shown, it being semi-elliptical in shape, the diameter of the base forming the minor axis, whilst half the major axis is the distance between the base at X and G.

Points G, F, and D are shown projected from the joint line to the elevation. The method of obtaining the true lengths of lines on the surface of the object, drawn between points on the top edge and points on the joint line, is the same as for previous problems. True length line 5-F on the branch, for instance, is projected from points 5 and F on to the elevation, in which it appears as a false length. The difference in the length of the projector from 5 on the top edge to 5 on the elevation and the projector from F to F is made apparent by the line 5-F drawn from F, parallel to the vertical plane. This line forms the base of the shaded triangle 5-F-5 and its position in the lay-out is determined by measuring the length of the ordinate F from a point on the lay-out perpendicular denoting the centre of the top of the object.

PATTERN FOR BREECHES PIECE

The method of developing the pattern for the branch is shown in Fig. 14. Draw an elevation A-0-6-G-X and produce the base line to D. Next describe a semicircle on the top edge and divide it up into six equal parts. Number the points 0, 1, 2, 3, etc., as shown. Drop perpendiculars to the top edge, so obtaining the ordinates for the lay-out. Describe a semicircle on the base edge, divide one-half into three equal parts and mark the points A, B, C, and D. Draw in the ordinates to the base line.

The shape of half the joint cut is next drawn on X-G. A quarter-ellipse is drawn between points D and G and points E and F, marked in at suitable positions on the curve. Place in the ordinates to the joint line X-G, as shown. Divide up the elevation surface into triangles by connecting the points on the edges by means of false length lines. The true lengths of the elevation triangles are obtained on a lay-out, which is constructed as follows. Erect a vertical line of indefinite length in a convenient position and mark off a point,

0, on it. Measure down from 0 the lengths of the ordinates from the elevation top edge, numbering them 1 and 5, 2 and 4, and 3. Also from 0 mark off the lengths of the ordinates from the base and joint face. Draw lines of indefinite length from the points found and mark them A, B, C, D, E, and F

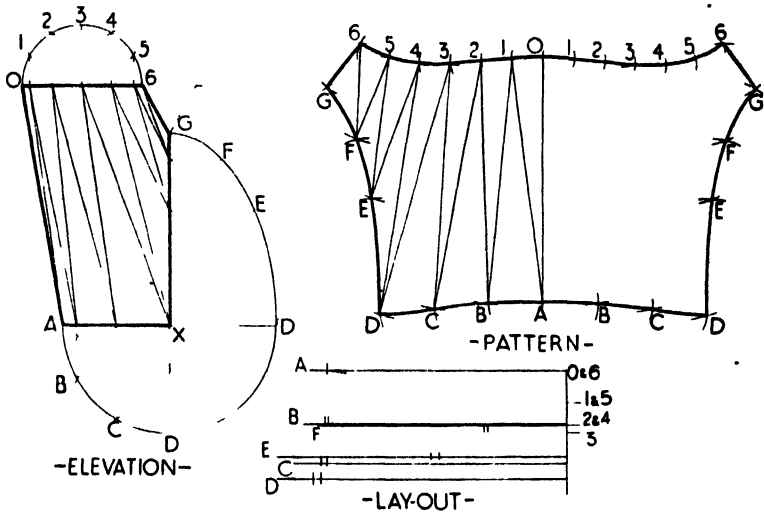

FIG. 14.

respectively. Note that line A is drawn from 0, because the breeches is symmetrical about its plan horizontal centre line, so points 0 and A are on the same plane. The base line, D, of the lay-out actually represents the position of the vertical plane in its correct relation to the horizontal centre line.

To start the pattern, draw a line 0-A in a suitable position. This is the edge line 0-A in the elevation, and it is made the middle line of the pattern to ensure that the seam will be at the smallest part of the branch. Now pick up with the dividers the false length 1-A from the elevation and mark it along line A in the lay-out, measuring from 0. From the point marked draw a line (shown dotted) to 1 on the perpendicular, to obtain the true length of 1-A. Add this line

to 0-A in the pattern lay-out by describing with it arcs each side of 0, using A as centre. Cut these arcs from 0 with the spacing 0-1 from the top edge semicircle. Next take the false length 1-B, mark it off along line B in the lay-out, from the corner of the angle, and join to 1 on the perpendicular. It is not really necessary to draw a line between the points, as the true length distance is picked up with the dividers. With the true length 1-B describe arcs each side of A in the pattern lay-out, using 1 as centre. Cut these arcs in B with the spacing A-B from the base semicircle. Pick up the false length 2-B from the elevation, step it along B in the lay-out and triangulate to 2 on the perpendicular. Strike arcs with the true length from points B in the pattern and cut them in point 2 with distance 1-2.

Each half of the pattern is built up on the same principle, care being taken to step off each false length in turn on its appropriate lay-out line and triangulating to the correct number on the perpendicular. To add line 2-C to the pattern, pick up the elevation false length, step it off on lay-out line C, and extend to 2 on the perpendicular. Describe arcs from point 2 in the pattern and cut them in C with spacing B-C. Obtain lines C-3, D-3, and 4-D in similar fashion. For pattern line 4-E take the false length from the elevation, mark it off on lay-out line E, and triangulate to 4 on the perpendicular.

From centre 4 in the pattern describe an arc with the true length and cut it in E with spacing D-E from the quarter-ellipse in the elevation. Take false length E-5, obtain its true length in lay-out, swing an arc from E in the pattern and cut it in 5 with spacing 4-5. Continue the remainder of the development similarly, using spacings E-F and F-G from the elevation, as shown. The edge or seam line G-6 is a true length, and as such is picked up direct from the elevation. Finally, draw an even curve through all the base and top edge points.

MULTIPLE JUNCTION PIECES

Fig. 15 shows one branch of a three-way piece, placed on a horizontal plane in such a position that its centre line 0-6

is parallel to the vertical plane. The round inlet is inclined to the base, which is divided up into three equal sectors. It can be seen that the face of the joint cut is quarter-elliptical in shape, and the projected view of this in the elevation is shown by the line drawn from C to G. Two more similar branches can be fitted together to form the three-way, but it must be clearly understood that any other shape of branch can be

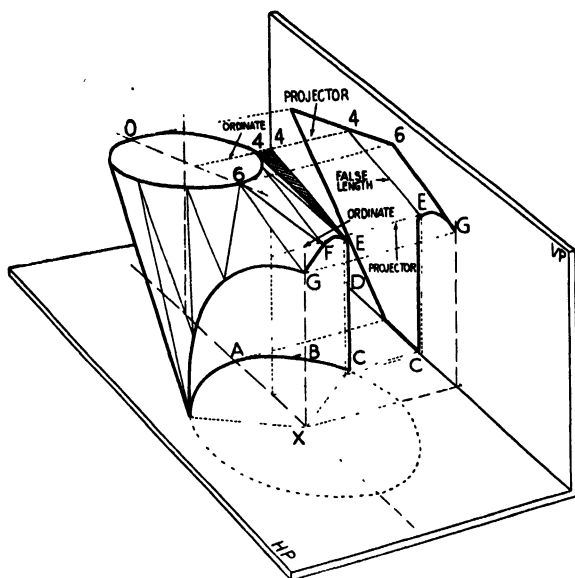

FIG. 15.

inserted into the sectors if desired, providing, of course, that one adheres to the same shape of base and joint contour from C to G. In this manner one of the branches could have its inlet parallel to the base, whilst another branch could have a square inlet, and so on.

The elevation of each branch is drawn separately with the correctly projected shape of the joint line placed in. Junction pieces with four or more branches are made in practically the same manner, the only difference being that the base is divided up into the required number of sectors, with a consequent

difference in the contour and position of the elevation joint curve. Branches made on this principle are easily and rapidly put together. It is a good plan when shaping-up to use a template cut to the contour of the joint curve, each branch being then shaped to it. This process enables the parts to be assembled with a minimum of trouble. There is no need in every case to make the joint curve semi-elliptical, as deviations from this shape can be used. A good appearance, for example, can often be given to the branches by making the curve at F (Fig. 15) much more full and higher than point G. The principle of obtaining true length lines is the same as for previous problems, as a study of the perspective view will make clear.

PATTERN FOR THREE-WAY JUNCTION PIECE

To obtain the pattern, as shown in Fig. 16, draw an elevation, A-0-6-G-X, of one branch. On the base line describe a semi-circle representing half of the base outline. As the base of the junction piece is divided up into three parts it is necessary to draw in the sector A-X-C, as depicted in Fig. 15. To do this, divide a quarter of the base outline into three equal parts, mark B and C and join C to X. Now draw in ordinates from B and C to the base line. Adjacent to the elevation next construct the true shape of the joint face by erecting a line parallel to X-G, cutting it off the same length, and drawing X-C at right angles to it. Join C to G by an elliptical curve and divide it up into suitably spaced parts C-D, D-E, E-F, and F-G. Next draw ordinates to X-G. From X in the elevation measure off these ordinates along X-C from X, and from the points found erect lines of indefinite length parallel to X-G. The lines are shown dotted up to the base line, and these distances are used for the lay-out construction. Draw lines from D, E, and F on the joint face parallel to the base, to the elevation line X-G. Where these lines intersect those drawn through the elevation from X-C gives points D, E, and F. Draw a smooth curve through the points. Next describe a semicircle on the elevation top edge, divide it up into six equal parts, number the points 0, 1, 2, etc., and place

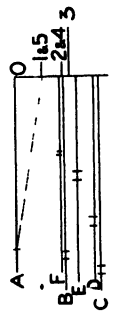
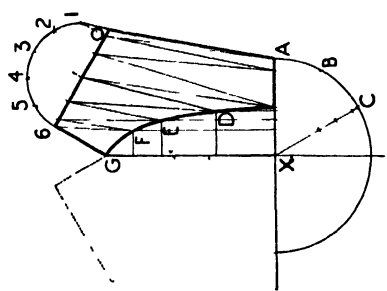
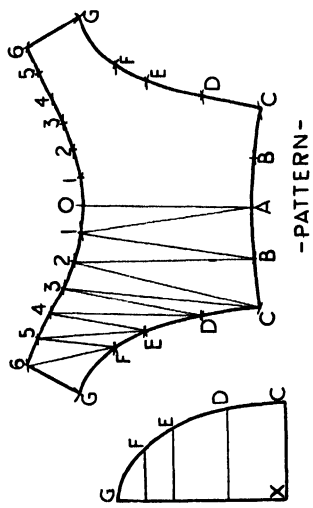

FIG. 16.

in the ordinates. Join the points on the edges and joint line of the elevation by means of false length lines, so obtaining the surface triangles. Construct the lay-out by drawing a vertical line, marking point 0, measuring down the top edge ordinates and numbering them as shown. Take the lengths of the dotted lines between X-C and X-A and mark them off from 0 on the lay-out perpendicular. Mark these lines D, E, and F, also place in the lay-out lines A, B, and C. It is very important to note that the widths between the line X-C and the base line be used for the lay-out and not the ordinates from the quarter-ellipse.

The pattern is developed in the same manner as for the breeches piece, each false length from the elevation being triangulated on the lay-out and the true lengths used to build up the pattern triangles. Take the spacings 0-1, 1-2, etc., from the top edge semicircle for the top line of the pattern and the four spacings A-B and B-C from the base semicircle. Also take the distances C-D, D-E, E-F, and F-G in the pattern from the true joint curve, as they must not be confused with the spaces on the elevation joint line. After all the triangles have been constructed, join up all the points with a smooth curve to complete the pattern.

Chapter Five

SPECIAL TYPES OF JUNCTION PIECES

THERE are occasions when it is necessary to make an air-duct breeches piece with a flush side to enable the job to lie flat against a wall or bulkhead. This means that the inlets are off-centre from the base of the breeches, and consequently this difference in design from previous examples has to be taken into consideration when constructing the layout used for developing the patterns. In Fig. 17 is shown the elevation and end view of a flush-sided breeches, the circular inlets of which lie at an angle to its round base. As both branches are identical in shape and size the triangulation of the elevation surface of one branch only is called for. It is not essential to draw a full end view for developing purposes, as all that is required is the shape of the joint curve, drawn adjacent to the elevation.

FLUSH-SIDED BREECHES PIECE

The pattern is obtained by the following means. First draw the elevation of one branch, as depicted in Fig. 17, and describe a semicircle on the top edge. Divide it up into six equal parts, 0-1, 1-2, etc., and draw in ordinates from the points to the edge line. Through the base line also describe a semicircle, divide into six equal parts, mark the corner A and the points below the base line, B, C, and D. The points above the base line are next marked *b*, *c*, and *d*. Join B to *b* and C to *c*, thus obtaining points on the base edge for the elevation triangles. Mark off ordinate 3 from the top edge, from D on D-*d*, and draw a line 0-6 through 3, parallel to the base edge. This line represents the position of 0-6 in its relation to the base, and it is used as a datum line to obtain

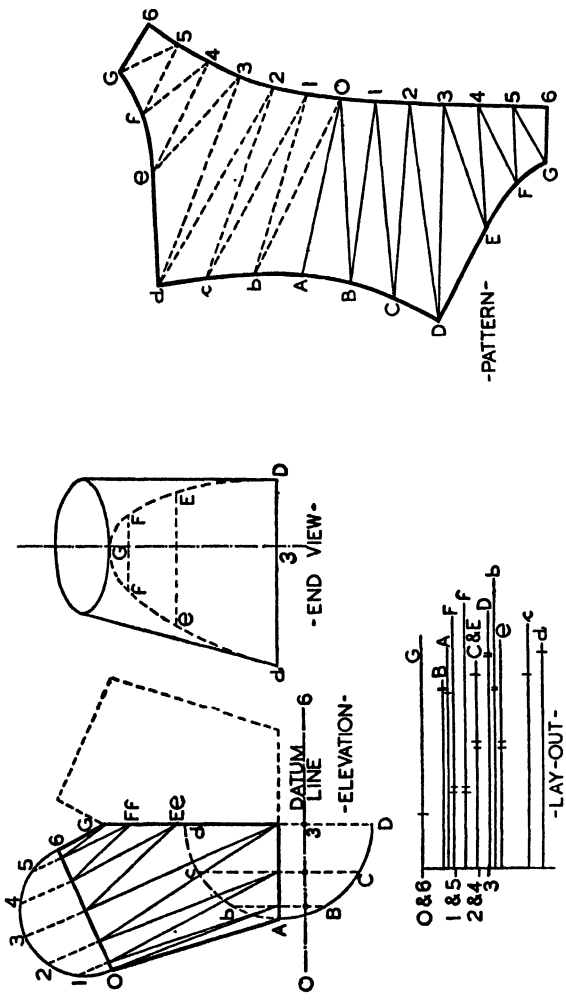

FIG. 17.

points for the lay-out. On an extension of the elevation base line construct the shape of the joint face between the branches by marking off $D-d$ from the elevation. Next measure $D-3$ from the base semicircle from D , and erect a perpendicular from 3 . Mark off the height of the joint line at G and draw in a suitable joint curve through G from points D and d . Divide the curve into a convenient number of spaces $D-E$, $E-F$, etc., and join by parallel lines points F and f and E and e . Project points e and f across to the elevation joint edge and mark as shown. Join all the edge points by lines to form the elevation triangles. Note that the base edge point determined by $B-b$ is joined to 0 on the top edge, as this is essential to the correct development of the pattern.

To construct the lay-out for obtaining the true length pattern lines, draw a vertical line of indefinite length and mark on it a point 0 and 6 . Step off from 0 and 6 the top ordinates, marking them 1 and 5 , 2 and 4 , and 3 . From 3 draw a horizontal line of indefinite length and mark it D . Measure on the perpendicular from 0 and 6 the widths between B and C on the base semicircle and the datum line. Draw lines from the points, parallel to D , marking them B and C respectively. Next measure the width between A and the datum line and place line A in the lay-out. Repeat this procedure for lines b , c , and d , measuring them off from 0 and 6 . These distances are those which lie between b , c , and d on the base semicircle and the datum line. Now measure the distances between line $G-3$ on the end view of the joint face, and E , F , f , and e respectively, and place these lines in their correct positions in the lay-out, as shown. Finally, draw G from 0 and 6 . To be theoretically correct the pattern development calls for two lay-outs, as the positions of the projectors are being determined to contiguous vertical planes each side of the top centre line, but in practice the base and joint face widths are all marked down the perpendicular from 0 and 6 . This simplifies the construction of the lay-out without any sacrifice of accuracy.

To start the pattern, pick up with the dividers line $0-A$ from the elevation. Mark this distance off along line A in

the lay-out, measuring from the corner. From the point found extend the dividers to 0 on the perpendicular. Draw this true length 0-A in a suitable position, using it as the middle line of the pattern. Next take line 0-B from the elevation, measure it along B in the lay-out, and join to 0. With this length describe an arc from 0 in the pattern lay-out, and cut this arc in B with the spacing A-B from the elevation base. Take elevation length 1-B, measure it along lay-out line B, and triangulate to 1 on the perpendicular. To add this true length to the first pattern triangle, describe an arc from B and cut it with the spacing 0-1 from the top-edge semicircle. Take line 1-C from the elevation, mark off along C in the lay-out, join to 1, and describe an arc from 1 in the pattern ; cut it in C with spacing B-C.

Repeating this procedure for the remainder of the elevation false lengths completes half of the pattern, using the distances D-E, E-F, and F-G from the joint curve in their correct positions in the pattern. Take the end line 6-G directly from the elevation, as it is a true length. Triangulate the remaining half of the pattern by picking up with the dividers the same elevation lines, but marking them off on *b*, *c*, *d*, *e*, and *f* lines respectively in the lay-out. For instance, take elevation length 0-*b*, measure it along lay-out line *b*, and extend to 0 on the perpendicular. Describe with this true length an arc from 0 in the pattern, cutting it in *b* with the arc A-*b*. Construct the remaining triangles similarly, taking care to place the elevation lengths on their appropriate lettered lines in the lay-out, and triangulating to the correct numbers on the perpendicular. The correct spacings from the joint curve must also be used, but careful consideration of the markings will prevent the possibility of errors. Complete the pattern by drawing smooth curves through all the points.

DESCRIPTION OF ALTERNATIVE LAY-OUT

The objects so far described have had their patterns developed from lines drawn on their elevation surfaces and made into true lengths in a lay-out. Certain types of jobs, however, lend themselves to easy development from their end

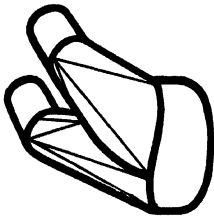

(c)

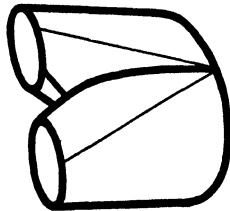

(b)

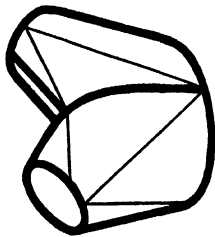

(a)

(d)

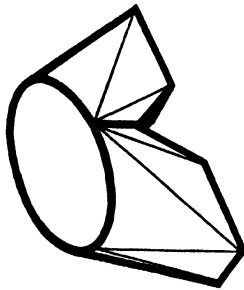

(f)

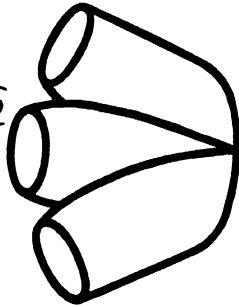

(e)

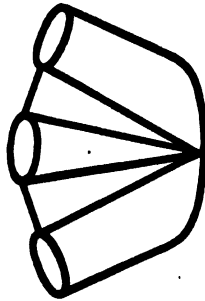

- (a) Flush-sided Breeches Piece, p. 39.
(b) Flush-sided Breeches with Parallel Ends, p. 45.
(c) Two-way Transition Elbow, p. 47.
(d) Rectangular to round Two-way Piece, p. 49.
(e) Three-way Junction Piece, p. 51.
(f) Three-way Piece, Alternative Design, p. 53.

On this line is measured off the length of the projector from 3' to the vertical plane, marking point 3'. The points 0 and 3 are also marked off as shown, and point D projected from the base edge. From this point a line of indefinite length is drawn parallel to line J. In the end view a false length line is drawn between points on the top and base edges, determined by the position of the ordinates 3 and D. The joint curve—shown dotted—is cut by the false length at J. Point 3 is also marked 3' because 3' in the elevation lies directly behind it. Thus 3-D is the end view of the elevation line 3-D and it covers the edge line 3'-J. These lines are made into true lengths in the lay-out; false length 3-D is measured along line D, and extended to 3, whilst 3'-J is marked off on line J and joined to 3'.

This lay-out can be used for the development of any job in which the end view has a less complex outline than that of the elevation.

FLUSH-SIDED BREECHES WITH PARALLEL ENDS

Fig. 19 depicts this method applied to the breeches piece shown in Fig. 18. Although an elevation is drawn, there is no necessity for this in actual practice, as the only dimension needed from it, the distance 0-P, can be taken direct from the working drawing. The job is tackled as follows: Draw an end view 0-6-G-A of one branch and on the top edge describe a semicircle. Divide this into six equal parts and draw in ordinates to the top edge, marking them 1, 2, 3, 4, and 5. Next describe the base semicircle, divide up as shown, and place in the ordinates B, C, D, E, and F. Draw in the shape of the joint face to the desired contour. Connect the points on 0-6 to the base edge points, joining 1 to B, 2 to C, and so on. Where these lines cut the joint curve gives points H, I, etc. Place in the remainder of the connecting lines to form the required triangles. The dotted lines are on the throat of the branch. Construct the lay-out in a suitable position by drawing an indefinite line and marking a point 0 and 6 on it. On each side of 0 and 6 measure off the lengths of the top edge ordinates, marking them with the appropriate numbers.

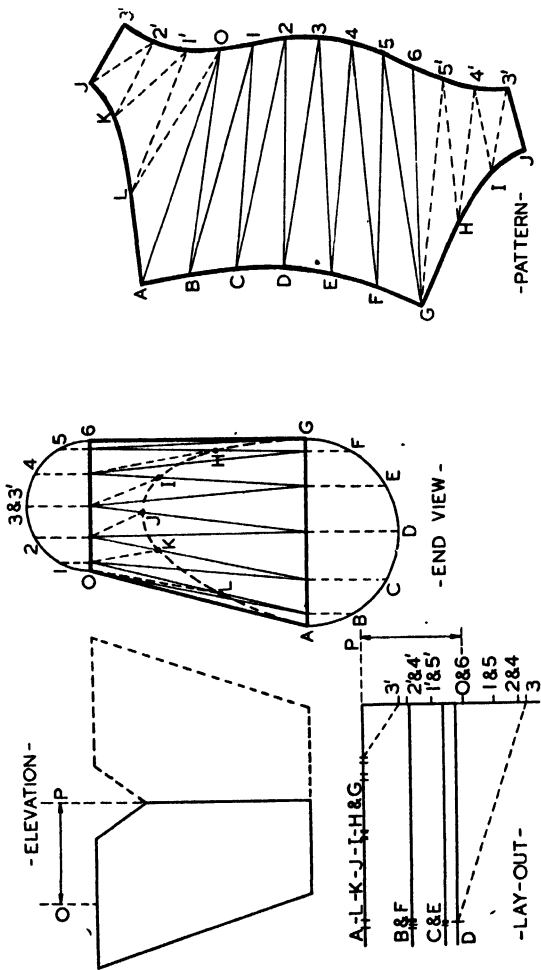

Fig. 19.

Note that the points above 0 and 6 are marked with a dash to distinguish them from the points on the outer edge of the inlet. The edge line of the vertical plane is now placed in the lay-out by measuring the elevation distance 0-P from 0 and 6 and drawing a horizontal line from this point. Mark this line A, L, K, J, I, H, and G, as all these points lie on the vertical plane. Next measure down from P the ordinates B, C, and D from the base semicircle and draw lines parallel to line A . . . G, marking them with their respective letters.

To draft the pattern, pick up the false length 3-D and step it along D in the lay-out. Join to 3 on the perpendicular and draw the true length in a suitable position, using it as the middle line of the pattern. Next obtain the true length of 3-E, along line E in the lay-out, by triangulating to 3. Describe an arc with 3-E from 3 on the pattern middle line and cut it in E with the spacing D-E. Continue constructing the pattern triangles in this manner, but care must be taken after drawing line 6-G that the preceding line 5-G be again picked up, although on this occasion it is connected to 5' on the perpendicular because this line is on the throat, the top edge points of which are marked with a dash in the lay-out. The next line, 5'-H, is now marked off on the top line of the lay-out and connected to 5'. Spacings G-H, H-I, etc., are taken direct from the joint curve to the pattern. Complete the pattern by working on the above lines, finally joining all points with a smooth curve.

The branch when shaped up can be joined to the branch described in Fig. 17 to form a breeches piece, which will converge the air flow from two different points to a main pipe, if such piping be fixed to a flat surface.

TWO-WAY TRANSITION ELBOW

The object shown in Fig. 20 is a transition elbow of original design. It is used for conveying sawdust or similar material from two adjacent hoods to a circular pipe, placed at right angles to the hood outlets. The method of developing the branches is similar to that of the previous example, with the exception that, as the ends of the branches are elliptical in

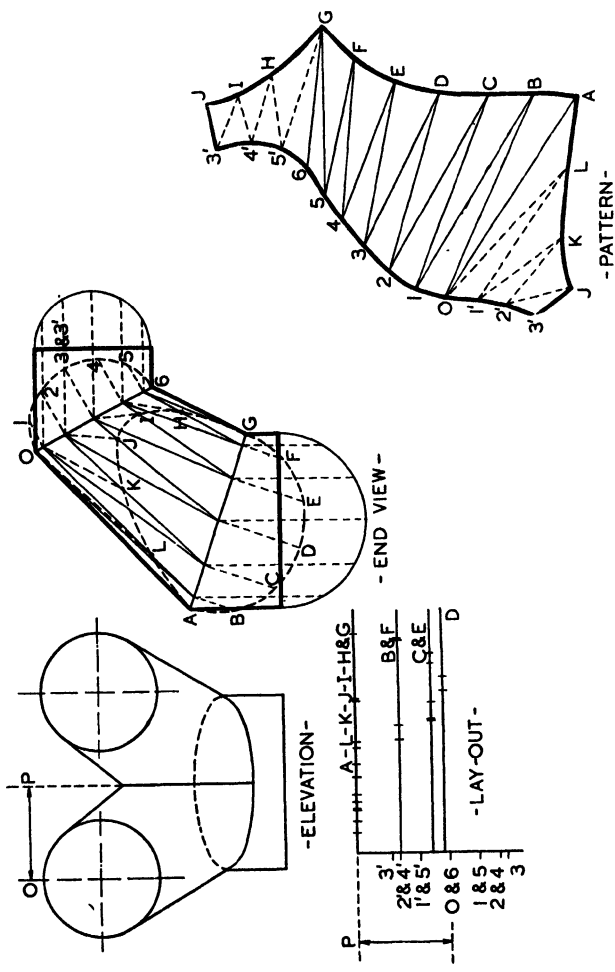

FIG. 20.

shape to fit to the elbow joints, it is necessary to draw these shapes on the joint lines A-G and 0-6. To do this, divide semi-circles described on the elbow base lines into six equal parts, place in the ordinates and produce the lines to the joint lines as shown. From the points found, draw perpendiculars of indefinite length and cut these off the lengths of the ordinates from the elbow semicircles. Join the points with fair curves, numbering the top semi-ellipse points 1, 2, 3, 4, and 5, and the bottom semi-ellipse, B, C, D, E, and F. Triangulate the branch pattern as for Fig. 19, taking care to pick up the spacings from the semi-ellipses for the pattern triangles and not those on the elbow semicircles. Mark the second branch off from the pattern and complete the laying-out of the job by obtaining the elbow patterns, using the parallel-line method of development.

Chapter Six

SPECIAL TYPES OF JUNCTION PIECES—Contd.

IN addition to the junction-piece problems already dealt with, there are other designs which call for some thought when tackling their patterns. Of these, the following examples are typical of many jobs encountered in everyday workshop practice. Fig. 21 shows the elevation and end view of a two-way junction piece with identical branches. Each

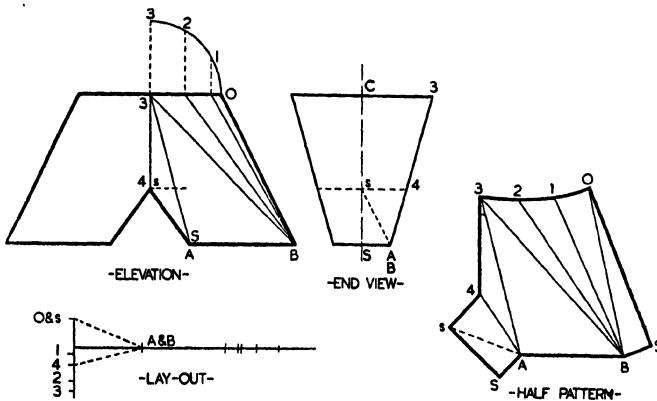

FIG. 21.

inlet is rectangular, and from this shape the branches transform to a round main pipe. The end view of the job is symmetrical about its vertical centre line and C-3-4-5 represents half of the shape of the joint face between the branches.

DEVELOPMENT OF RECTANGULAR TO ROUND TWO-WAY PIECE

To set-out the job, first draw the elevation 3-0-B-A-4 of one branch. On the top edge describe a quadrant, to represent

a quarter section of the outlet, and divide it into three equal parts. Number the points 1, 2, and 3, and drop perpendiculars from them to the top edge. These lines—shown dotted—are ordinates required for the lay-out construction. Connect the points on the top edge to points A and B with false length lines, to divide the elevation surface into triangles. Next draw the end view of the branch. Project elevation point 4 across horizontally to the end view. Distance $s-4$ is half the width of the throat.

Now construct a lay-out in a suitable position. Draw a vertical line and mark a point 0 and s . From this point measure off and number the ordinates from the top edge. Take distance $s-4$ from the end view and also measure it from 0 and s , marking point 4. Next take distance A-S from the end view, measure from 0 and s , and from the point found draw a horizontal line of indefinite length. Mark this line A and B.

To start the half-pattern draw a line $s-S$ for the throat seam in a convenient position. This line is marked $4s$ and AS in the elevation, and it represents *three* lines, the seam $s-S$, which is a true length; the outside edge line 4-A, which appears as a false length in the elevation; and line $s-A$, shown as a dotted line in the end view. Measure line $4s-AS$ along line A and B in the lay-out, stepping it off from the corner of the angle. From the point marked, join to points 4 and s on the perpendicular to obtain true length lines.

Take the true length $s-A$ and strike an arc from s on the first pattern line previously drawn. Cut this arc in A with distance AB-S from the end view, using S as centre. Next take true length 4-A from the lay-out and describe an arc from A in the pattern lay-out. Pick up distance $s-4$ from the half-end view and cut the arc just drawn in 4, using s as centre. For the next pattern triangle take false length 3-A from the elevation, measure it along lay-out line A and B, and extend from the point found to 3 on the perpendicular. Describe an arc with this true length from A in the pattern lay-out and cut this arc in 3, from centre 4, with distance 3-4 from the end view.

To continue the development, take elevation false length

3-B, measure it along the lay-out horizontal line, and triangulate to 3 on the perpendicular. To add this line to the half-pattern describe an arc from 3, and cut it in B from centre A, with the elevation distance A-B. Next take false length 2-B (the full line) and step off on the lay-out horizontal line. Extend from the point to 2 on the perpendicular, and with this distance strike an arc from B in the development. Cut this arc in 2 from centre 3, with the spacing 2-3 from the quadrant on the elevation top edge.

Similarly, find the true lengths of 1-B and 0-B, and add to the half-pattern. Finally, take the edge line 0-B, using it this time as a true length, and describe an arc from 0. Take AB-S from the end view and cut the arc just drawn in s, from centre B. Join points 0 to 3 with an even curve. The full pattern can be obtained, if desired, by reproducing the lines already drawn.

THREE-WAY JUNCTION PIECE

The next example, illustrated in Fig. 22, is a three-way

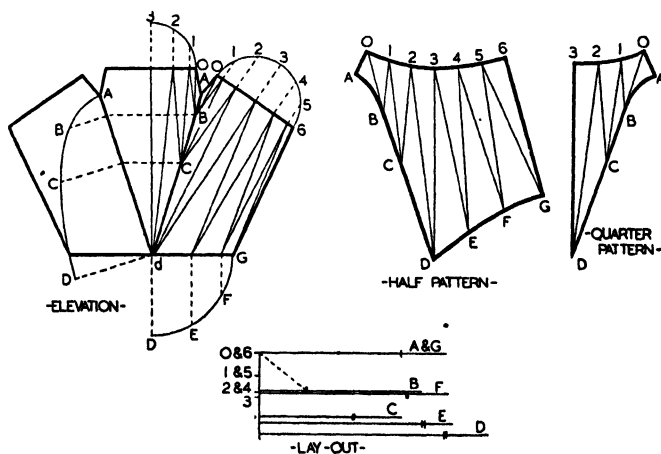

FIG. 22.

junction piece, the inlet and outlet centres of which are on the same vertical plane. The outside branches are identical

in shape and size, thus only the development of a half-pattern is necessary. A quarter-pattern for the middle branch is shown, it being used as a template to obtain the full pattern. Both developments are obtained using the same lay-out. The half-pattern for the outside branches is drafted as follows :—

Draw the elevation as shown and describe a semicircle on the top edge of one of the outside branches. Divide it up into six equal parts and draw perpendiculars to the top edge. Describe quadrants on the top edge of the middle branch and the base edge of the junction piece. Divide these quadrants up into three equal parts and draw in ordinates. Number and letter all the points as shown.

Next draw ordinate d -D equal to the base radius on the joint line d -A, and describe an elliptical curve from A to D. This is the half-section of the joint between the branches. Divide the curve into three suitable parts, A-B, B-C, and C-D, and draw ordinates from B and C to the joint line. Project the points horizontally to the opposite joint line, and connect the edge points with false length lines to form the elevation triangles.

Draw the perpendicular of a lay-out and from a point 0 and 6 draw an indefinite horizontal line. Measure the top edge ordinates from 0 and 6 and mark the points with their appropriate numbers. Now measure from the point the joint and base line ordinates, draw indefinite horizontal lines from the points, and letter as shown.

To commence the drafting of the half-pattern, draw the seam, which is the true edge line 0-A, in a suitable position. Pick up false length 0-B on the outside branch, mark it off on lay-out line B, and extend to 0 on the perpendicular. Strike an arc with this distance from 0 on the pattern seam and cut it in B, with spacing A-B from the quarter-ellipse, using A as centre. Next take elevation length 1-B, step off on lay-out line B, triangulate to 1 on the perpendicular, and swing an arc with the true length from B in the pattern lay-out. Cut this arc from centre 0, with spacing 0-1 from the inlet semicircle.

Take false length 1-C, mark it off on lay-out line C, extend

to 1 on the perpendicular, and with this distance describe an arc from 1 in the development. Strike an arc from B with spacing B-C from the quarter-ellipse, to cut the arc previously drawn in C. Continue this procedure with false length 2-C and the remaining connecting lines on the elevation surface. Each false length in turn is extended to a true length by measuring it along its correctly lettered lay-out line and joining to the appropriate number on the perpendicular. The pattern triangles are built up with the true length lines and the spacings from the half-sections on the elevation edge lines. Development of the quarter-pattern for the middle branch is accomplished in exactly the same manner and should present no difficulties if the example given is carefully followed.

ALTERNATIVE DESIGN FOR THREE-WAY PIECE

Instead of being formed of three separate branches, the job can be made in two parts. This method, illustrated in

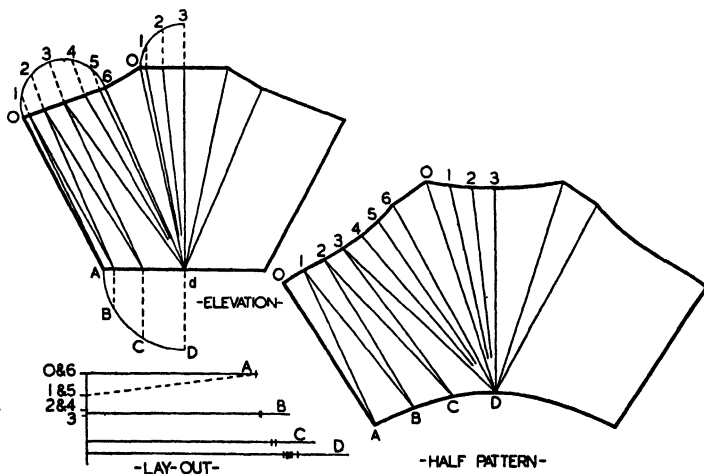

FIG. 23.

Fig. 23, has certain advantages, one of which is that troublesome fitting of the branch joints is avoided. The

patterns, however, require a certain amount of care in shaping up.

Between the branches of the way-piece are formed four triangular connecting pieces, one of which is marked 6-*d*-0 in the elevation. The top edges 0-6 are the joints between the front and back triangles. No difficulty should be experienced in drafting the half-pattern, as both this and the lay-out construction are similar in principle to previous examples. Use the half-pattern as a template for the other side of the job. Note that all the connecting lines, with the exception of the seams, marked 0-A, are false lengths, and, as such, must be made into true lengths in the lay-out. The top edge joint lines 0-6 are true lengths in the elevation. Care must be taken to arrange the elevation triangles as shown to enable the patterns to be shaped up in the folders with the minimum of trouble.

TWO-WAY PIECE WITH UNEQUAL BRANCHES

Fig. 24 shows a junction piece with inlets of different diameters which transform to a rectangular base, both branches being joined up with triangular pieces marked in the elevation 6-B-0'. The lay-out for this job has the ordinates from the inlet half-sections marked off on the perpendicular from the same point, as shown. From this point is also marked off the base half-width *a*-A from the half-end view and a horizontal line of indefinite length is drawn through the point. On the left-hand side of the lay-out is measured off the false lengths from the smaller branch, the other branch connecting lines being stepped off on the right-hand side. Note that the edge line 6-0' is a true length and that the edge lines 0-A*a* and 6'-C*c* represent both true edge and false length lines ; all the remaining connecting lines between the inlet and base edges must be made into true lengths in the lay-out.

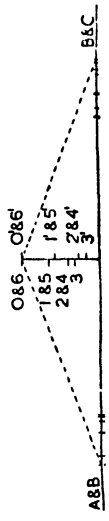
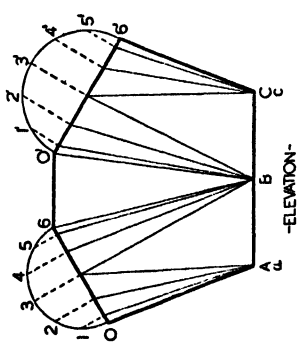
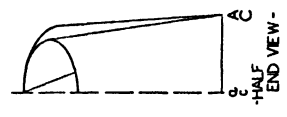
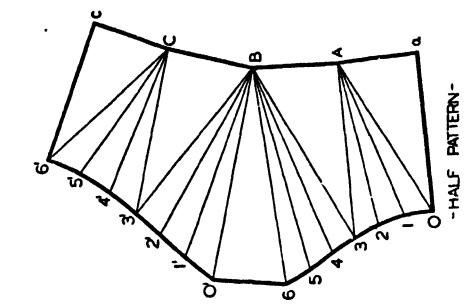

Fig. 24.

Chapter Seven

CONES INTERSECTING CYLINDERS

AIR-duct branch connections are often made conical in shape and of long taper. Thus the drafting of their patterns by the radial-line method is sometimes not a practical proposition, although such a course is usually

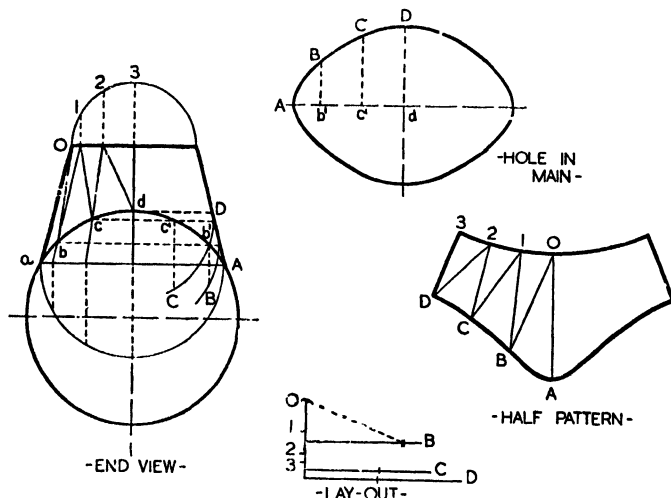

FIG. 25.

advocated for work of this nature. Fig. 25 shows the end view of a conical branch connection to a round main. The centre line of the branch is perpendicular to that of the pipe. By using the lay-out system it is possible to obtain the pattern by triangulation, after the shape of the pipe

hole in the flat has been found. It is necessary to find this shape, because the hole perimeter gives the correct length of the joint line between the parts.

CONICAL BRANCH CONNECTION

The setting-out of the job to obtain the pattern and hole shape is as follows: First draw the end view of the duct, as shown, and describe a semicircle on the top edge. Divide one-half into three equal parts and number the points 0, 1, 2, and 3. Draw perpendiculars from the points to the top edge to obtain ordinates for the lay-out construction. Next mark the joint points a and A , and join up to form the cone base. Describe a semicircle on a - A , and draw perpendiculars to the base line from three equally spaced points on the semicircle, as shown. Connect the top and base edge points to cut the cylinder circumference at b , c , and d . Join 0 to b , 1 to c , and 2 to d , to form triangles. Draw horizontal lines—shown dotted—from b , c , and d to obtain points b' , c' , and D . The distance d - D is the cone half-width at the point where it meets the cylinder. Describe an arc from the edge line, on line c , using as radius the distance between the edge line and the vertical centre line. Drop a perpendicular from c' to cut the arc in C . Distance c' - C is the hole half-width at c' . Repeat this construction for b' - B .

Now set-out the shape of the hole in the cylinder. Draw an indefinite line in a suitable position and mark a point A . From A step off distances A - b' , b' - c' , and c' - d from the end view.

Erect perpendiculars from the points and cut them off in length the distances b' - B , c' - C , and d - D . Draw a smooth curve through the points to complete one-quarter of the hole. The full hole shape requires the repetition of the above construction.

To construct the lay-out draw an indefinite line for the perpendicular and mark a point, 0. Measure from 0 the ordinates on the top edge of the connection, and mark the points 1, 2, and 3 respectively. Next measure from 0 the distances b' - B , c' - C , and d - D . From the points found draw

indefinite horizontal lines and mark them B, C, and D, as shown.

To start drafting the pattern draw a line equal in length to the edge line 0-*a*. Take false length 0-*b* and mark it off on line B in the lay-out, measuring from the corner. Open the dividers from the point marked to 0 on the perpendicular, and with this true length strike an arc from 0 on the pattern line 0-A. Cut this arc in B, using A as centre, with the spacing A-B from the hole perimeter. Take 1-*b* from the end view, measure it along lay-out line B and join to 1 on the perpendicular. Describe an arc with this distance from B in the pattern lay-out and cut it in 1 from 0, with the spacing 0-1 from the top semicircle. Next pick up 1-*c*, measure off on lay-out line C, and triangulate to 1 on the perpendicular. With this true length swing an arc from 1 in the pattern lay-out, and using B as centre, cut it in C with spacing B-C. Repeat this construction for the remainder of the triangles. Step each false length in turn on its appropriate lay-out line, triangulate to the correct perpendicular number, and build up the pattern triangles in the usual manner. Join all the points with an even curve, the half or full pattern being drafted as desired.

ALTERNATIVE METHOD FOR PATTERN

Some of the geometrical construction described can be simplified if desired, for workshop use. Although branch connections or "shoes" are often conical in shape, it is not absolutely necessary that they be made portions of right or oblique cones, as an approximate shape is suitable in many cases. By constructing a hole of convenient shape and size it is possible to triangulate the connection surface with a minimum of lines. Where the "shoe" is of irregular shape this is the most practical method to adopt, although it must be clearly understood that the shape of the job depends upon the contour of the joint line or hole perimeter.

Fig. 26 shows a view of a branch connection similar to the last example. Draw a half-end view in a convenient position, as this is all that is necessary for the development of the pattern. Divide the joint line into three suitable parts and

mark the points *A*, *b*, *c*, and *d*. On the top edge describe a quadrant, divide it into three equal parts, and number the points 0, 1, 2, and 3. Draw in the ordinates and connect the points on the top edge to points *b*, *c*, and *d* on the joint line

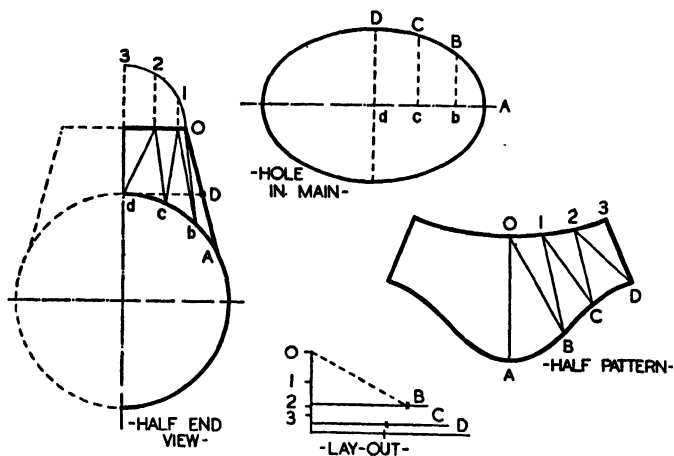

FIG. 26.

by means of false length lines. Project *d* to the edge line, obtaining *D*. This distance *d-D* is the half-width of the hole.

For the hole in the main draw an indefinite horizontal line and mark off on it the spacings *A-b*, *b-c*, and *c-d* from the joint line. Draw a perpendicular through *d* and mark off *d-D* each side of the horizontal line. This distance is the minor axis of an ellipse of which the major axis is twice the length of *A-d*. An elliptical curve drawn through the points is the required shape of the hole. Finally, erect perpendiculars from *b* and *c* to cut the perimeter at *B* and *C*.

Draw a lay-out in a suitable position. Measure off and number ordinates 1, 2, and 3 from the top edge of the job from a point marked 0 on the perpendicular. Next measure from 0 distance *d-D* from the hole, and draw a horizontal line *D* from the point. Take *b-B* and *c-C* from the hole and also mark off from 0. Draw lines parallel to *D* from the points and mark them *B* and *C* respectively. The half-pattern is

developed in exactly the same manner as for the previous example.

CONICAL HOPPER ON INCLINED PIPE

In Fig. 27 is depicted a conical hopper fitting at an angle to a round pipe. When the job is in position the top of the hopper lies parallel to the ground, but the pattern is most easily tackled from the views drawn as shown. In order to obtain the correct shape of the joint line between the hopper and the pipe it is necessary to draw an elevation and a half-end view. First draw the elevation and describe semicircles on the top and base lines of the cone frustum. Divide each of them into six equal parts and draw perpendiculars—shown dotted—to the edge lines. Now join up the edge points with straight lines. Next construct a half-end view projected from the elevation, with the semi-ellipses drawn in, as shown. Join the top points *b*, *c*, *d*, *e*, and *f* to the base points B, C, D, E, and F, intersecting the semicircle at points 1', 2', 3', 4', and 5'. Draw dotted lines from these points parallel to the cylinder centre line, to cut similar lines in the elevation. Through the points draw the joint line, and then join them up to the edge points on A-G to form triangles.

Next draw a perpendicular from 3 on the joint line to 0-6, marking X. Construct the shape of the hole in a convenient position. Draw a line equal in length to 0-6, mark off the distance 6-X and erect a perpendicular at X. Measure off from X the distances 0'-1', 0'-2', etc., from the half-end view. Draw horizontal lines from the points as shown, and make them equal in length to those distances which lie between similar numbered points on the joint line and 3-X in the elevation. Mark the points on the hole perimeter, 1, 2, etc., and join them up with a smooth curve.

To construct the lay-out draw a vertical line and mark a point 0 and 6. Measure the horizontal distances between a-G and points 1', 2', 3', etc., in the half-end view and mark them off on the lay-out perpendicular. Number the points 1, 2, 3, 4, and 5 respectively. Next draw a horizontal line from 0 and 6 and mark it A and G. Take the distances from

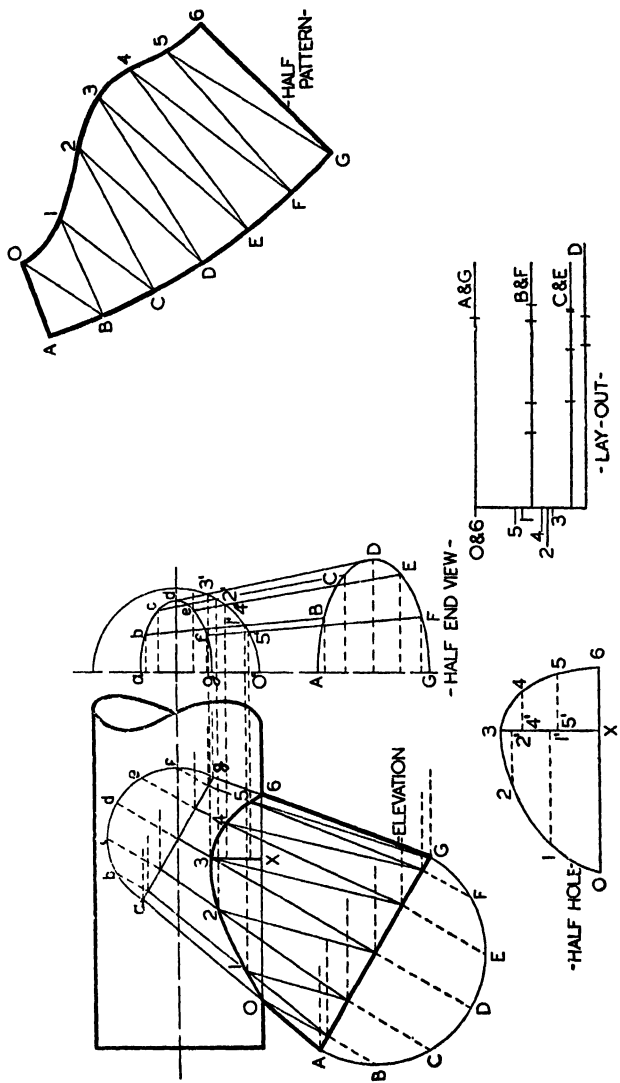

FIG. 27.

between A-G and the semicircle in the elevation, and measure off from 0 and 6. Draw horizontal lines from the points and mark them B and F, C and E and D respectively.

For the pattern, first draw the edge line A-0. Next take 0-B from the elevation, measure it along lay-out line B, and triangulate to 0 on the perpendicular. Strike an arc with this true length from 0 on the edge line and cut it in B with the spacing A-B from the cone. The rest of the half-pattern is developed on similar lines and should present no difficulties if the example given is closely followed. Note that spacings 0-1, 1-2, etc., are taken from the hole perimeter.

AN EASIER METHOD OF SETTING-OUT

The hopper pattern can be drafted with fewer lines by drawing an approximate elevation joint line and triangulating the surface of the job to the contour of the pipe hole. This method, which is illustrated in Fig. 28, can be used for many similar jobs in the workshop. First draw the elevation as shown, and describe a semicircle on A-G. Divide it up into six equal parts and draw perpendiculars back to the edge line. Drop a perpendicular from a suitable point x' on the pipe centre line and project X on the edge line across to the perpendicular marking X' . Draw a perpendicular from the point and make it equal to X-D from the semicircle. Next measure $x'-d'$ on the pipe centre line, equal to $x-d$, and join d' to D' . Describe an arc from x' with radius $x'-0'$ to cut $d'-D'$ in $3'$.

Divide the distance $0'-3'$ into a suitable number of parts and from the points draw dotted lines of indefinite length parallel to the pipe centre line. At the point where the dotted line from $3'$ cuts the hopper centre line, mark 3. Draw a suitable curve from 0 to 6, through 3, to cut the dotted lines at 1, 2, 4, and 5. Join these points by means of false length lines to the edge points on A and G.

Now construct the shape of the half-hole. On a vertical line mark off spacings $0'-1'$, $1'-2'$, and $2'-3'$, and draw horizontal lines from the points. Measure off from the perpendicular points 0, 1, 2, etc., using the same distances as between the

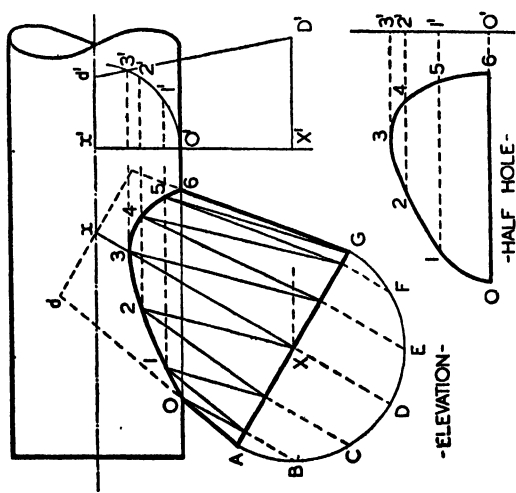
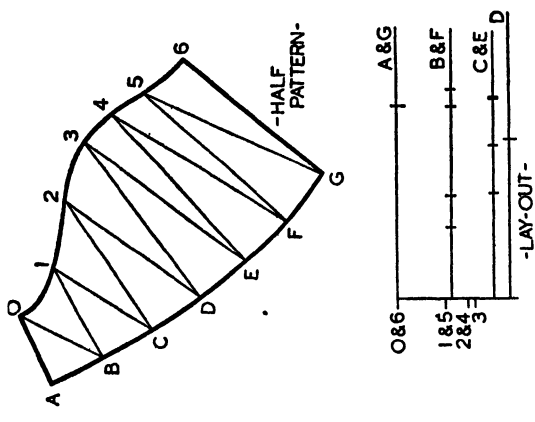

FIG. 28.

joint line points and the perpendicular $x'-X'$. Join up the points on the hole perimeter with a smooth curve. For the lay-out, make the distances from 0 and 6 on the perpendicular equal to the ordinates between $x'-0'$ and points 1', 2', and 3' on the arc. Number as shown. Also measure from 0 and 6 the appropriate distances from the base edge semicircle, and mark horizontal lines drawn from the points, as shown.

Develop the pattern in the usual manner by obtaining the true lengths in the lay-out, using the spacings 0-1, 1-2, etc., from the hole perimeter for the top edge points of the triangles. Although the hopper will not come out as a true portion of a cone, it will be practically the same in appearance; in fact, if the approximate joint line is drawn by a workman with an experienced eye there will be no apparent difference at all. The fit between the hopper and pipe, as in the last problem, should be perfect if the patterns are carefully drawn.

Chapter Eight

CONICAL INTERSECTIONS

PATTERNS for jobs which are made up of cone frustums fitting together are rather difficult to develop because of the necessity of locating the joint or intersection curve between the parts. Further complications arise if the frustums are of long taper, as this usually means that the patterns must be triangulated. Simplification of the problems involved can be accomplished by using the elevation surfaces as a basis for obtaining the pattern triangles, as this eliminates much tedious projection work required when triangulating from a plan of the job.

The shape of the line of intersection between the cone frustums is best obtained using the cutting plane method in which section lines are drawn across the elevation of the job in suitable positions. These lines are the elevations of sections made by cutting planes, and on them are located the joint line points derived from the intersections of the parts as depicted in the sections.

USE OF CUTTING PLANE METHOD

In Fig. 29 is shown the elevation of a conical branch connection to a tapered main connecting piece. A section line $X-Z$ is drawn across the elevation. The section of the horizontal cone at the cutting plane gives the circle $z-Z$; the slanting cone section appears as an ellipse, of which $x-X$ is the major axis. For the minor axis a section line $W-Y$ is drawn through c , in the elevation, square to the slanting cone centre line, and this cutting plane presents the circle $W-Y$. Point c , which is the centre of $x-X$, is projected to this section to obtain distance $c-c'$. By this means the half-width of the

smaller cone at point *c* is found. At the intersection of the circle and ellipse in the vertical section on X-Z is afforded a point C, which is projected horizontally to the section line

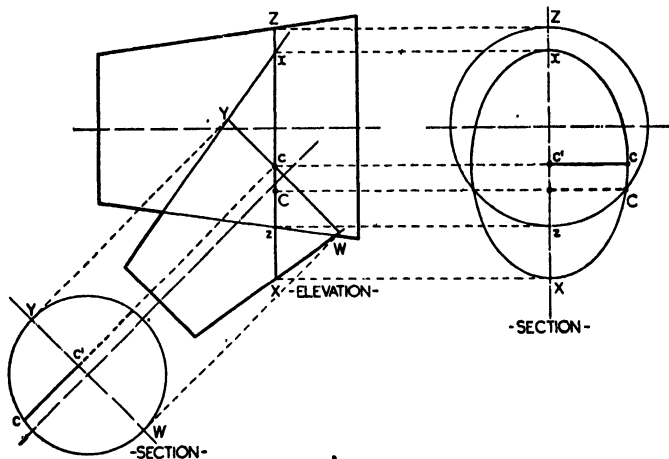

FIG. 29.

X-Z in the elevation to determine the similar lettered point on the line of intersection. Further points on this line can be found, using the same principle, of which a simplified construction is shown in Fig. 30.

Using this method of cutting planes also enables the lay-out triangulation system to be used for the drafting of the patterns, as part of the construction can be adapted for this purpose. The dotted line drawn from C to X-Z in the vertical section is an ordinate used in the lay-out construction, and the arc z-C is the distance required for the half-hole in the tapered piece at this point.

SETTING-OUT FOR CONICAL PIPE CONNECTIONS

Draw the elevation as depicted in Fig. 30. Produce the edge line 0-A of the branch indefinitely, and draw vertical section lines to intersect it through suitably spaced points B', C', and D' on the edge line between A and E. To obtain point D on the joint curve, bisect section line *f-g* to find point *d*.

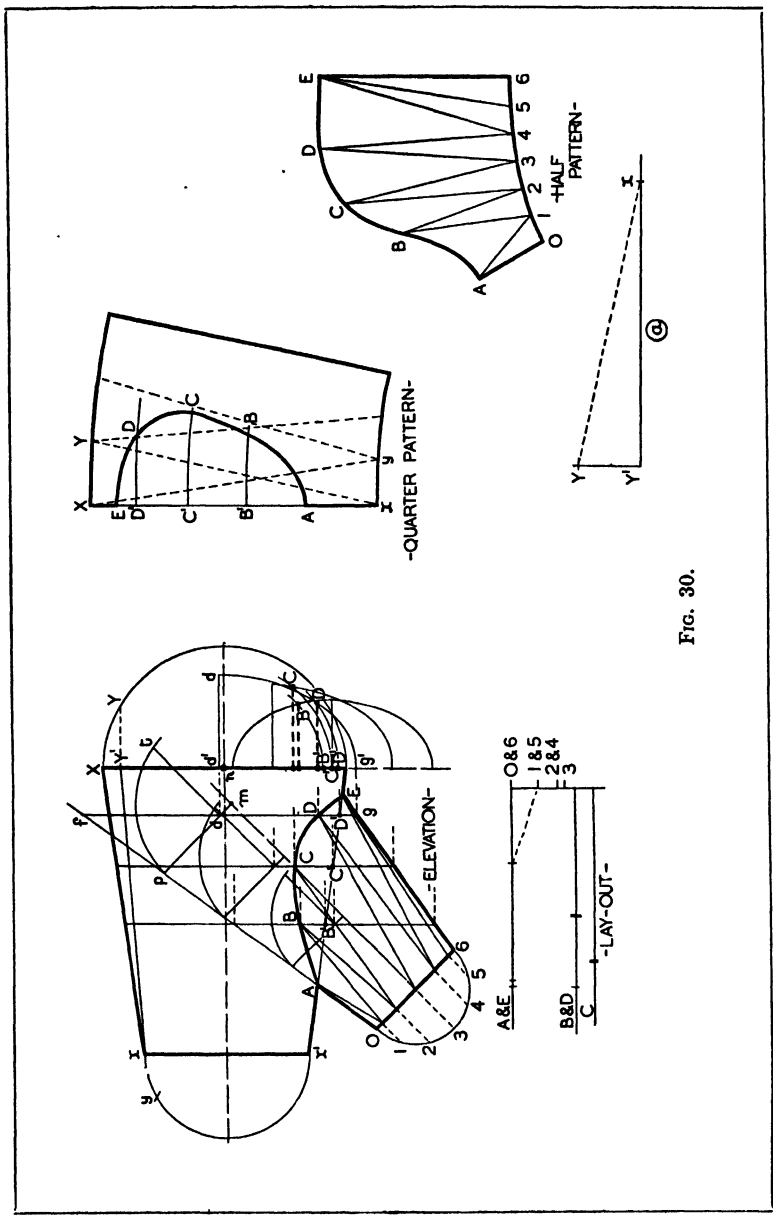

FIG. 30.

Through d draw $m-p$ perpendicular to the branch centre line. Describe an arc from m with radius $m-p$ and meet this in t with a line from d , perpendicular to $m-p$.

The distance $d-t$ is half the minor axis of the elliptical section of the cone at the cutting plane. Project d horizontally to the base edge of the horizontal frustum and draw a perpendicular to the edge line from the point found. Make $d-d'$ equal in length to $d-t$. Now project g on the section line to g' and draw an elliptical curve between d and g' as shown. Next project D' to the base edge $g'-X$, and with radius $n-D'$ describe an arc, with n as centre, to cut the quarter-ellipse in D . Project this point back to section line $f-g$, marking the point D . The dotted line between the base edge and D is an ordinate required later on in the lay-out construction.

Repeat this setting-out for the other section lines to obtain points B and C on the joint line, and draw in the curve between the points. (The half-section of the small cone on the section line through B' is drawn as a semi-ellipse to illustrate that point B is on the top half of this curve.) Draw a semicircle on edge line $0-6$, divide it into six equal parts, and project the points back to the edge line. Join the points on $0-6$ to A , B , C , D , and E on the joint line by means of false length lines to obtain the elevation triangles, as shown.

PATTERN FOR THE MAIN CONNECTING PIECE

The development for the horizontal tapered piece pattern is as follows, one-quarter only being shown. First describe a semicircle on the base edge in the elevation, using n as centre. Make the distance $X-Y$ one-sixth part of the semicircle and draw ordinate $Y-Y'$, shown dotted. Draw on the top edge a semicircle and make $x-y$ a one-sixth part of it. Join x to Y' with a false length line.

Next draw a right angle in a convenient position, as at (a) , and mark off ordinate $Y-Y'$ on the perpendicular and false length $x-Y'$ on the base line. Join x to Y to obtain a true length for the pattern. To start the pattern, draw the edge line $x-X$ in a suitable position. Take the true length $x-Y$ and describe with it an arc from x on the edge line. Cut this arc

in Y with spacing X-Y from the base semicircle. Next, with true length x -Y describe an arc from X and cut it in y with spacing x - y . Repeat this construction for the remainder of the development and join the points with an even curve.

From x on the edge line measure off distances x' -A, A-B', B'-C', etc., from the elevation and draw arcs of indefinite length from the points. These arcs are best obtained by measuring them off equidistant to the curve x - y . Cut the arcs off equal in length to arcs B-B', C-C', and D-D' on the base edge of the horizontal frustum and join up the points with an even curve, thus obtaining the shape of half the hole in the tapered piece.

Now construct a lay-out for obtaining the true lengths of the elevation triangles. Draw an indefinite vertical line and mark a point 0 and 6. From this point draw a horizontal line of indefinite length and mark it A and E. Take ordinates B, C, and D from the edge line g' -X and mark them down the lay-out perpendicular from 0 and 6. The ordinates are shown dotted, and in this example ordinates B and D are the same length. Draw horizontal lines from the points on the perpendicular and mark them as shown. Next, from 0 and 6 measure off the distances, shown dotted, between the semicircle and edge line 0-6 on the slanting cone. Mark the points with their respective numbers.

To start the branch half-pattern take edge line 0-A from the elevation and draw in a convenient position. Pick up false length 1-A and measure it off from 0 and 6 on line A in the lay-out. Extend the dividers from the point marked to 1 on the perpendicular, and with this true length strike an arc from A on the first pattern line. Cut this arc in 1 with spacing 0-1 from the branch semicircle, using 0 as centre. Next take false length 1-B, step it from the corner of lay-out line B, and triangulate from the point found to 1 on the perpendicular. Describe an arc with this distance from 1 in the pattern lay-out and cut it in B with spacing A-B from centre A. This spacing A-B is taken from the half-hole perimeter in the quarter-pattern of the tapered piece.

Now take false length 2-B, measure it along B line in the

lay-out and extend to 2 on the perpendicular. Describe an arc from B in the pattern lay-out with this true length and cut it in 2 with spacing 1-2, using 1 as centre. The remainder of the development is on similar lines, each false length in turn being extended to its true length in the lay-out and used to form the pattern triangles. Take care to place each false length on its similar lettered line in the lay-out and to triangulate to its appropriate number. The top-edge spacings of the half-pattern are all taken from the hole perimeter, and if carefully drawn there should be no trouble in completing the patterns to give a good fit between the parts when made up.

AN EASIER METHOD OF SETTING-OUT

A simpler method of obtaining the branch connection is shown in Fig. 31. One cutting plane only is used to find a point C on the line of intersection. A suitable curve is drawn through C from A to E, and from this is obtained measurements for the shape of the hole in the horizontal tapered piece. It must be emphasised that this is a method for workshop use, as the branch connection will not, strictly speaking, be a portion of a right cone, but it is correct enough for many practical purposes. As the shape of the branch is governed by that of the hole in the tapered piece, the fit between the two pieces of duct should leave nothing to be desired.

Lay-out the job in the following manner: First draw the elevation as shown. Divide distance A-E on the edge line of the tapered pipe into a suitable number of parts at points *b*, *c*, and *d*. Erect perpendiculars to the horizontal centre line from *b* and *d*. Draw a vertical section line through *c* from *p* to meet in *t*, edge line 0-A produced. Bisect *p-t* in *m*. Through *m* draw a line perpendicular to the branch centre line, marking *o*. Describe an arc from *o* with radius *o-P*. Raise a perpendicular from *m* to meet the arc in *h*. This distance *h-m* is the half-width of the cone at point *m*.

Now draw *m-n*, which is equal to *h-m*, square to the section line and connect points *n* and *p* with an elliptical curve. Next, using *c'* on the section line as centre, draw an arc with radius *c-c'* to cut the elliptical curve in C'. Project C'

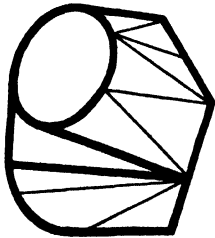

(a)



(b)

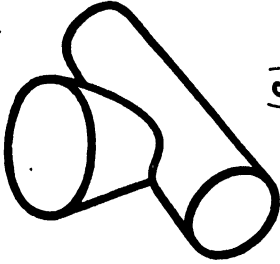

(c)

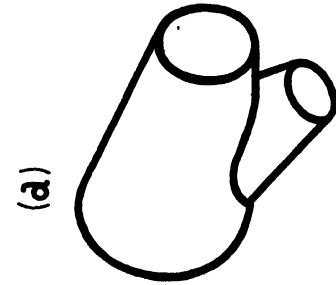

(d)

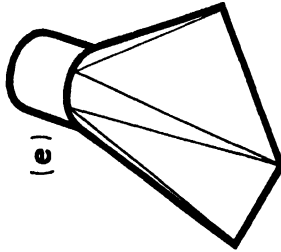

(e)

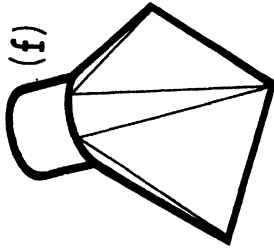

(f)

- (a) Two-way Piece with Unequal Branches, p. 55.
(b) Conical Branch Connection, p. 56.
(c) Hopper on Inclined Pipe, p. 61.
(d) Conical Pipe Connections, p. 67.
(e) Fan Outlet Connecting Piece, p. 78.
(f) Twisted Transformer, p. 81.

horizontally back to the section line to obtain C. Draw in the joint curve through this point from A to E to cut perpendiculars $b-b'$ and $d-d'$ in B and D respectively. Describe arcs from b and c , using b' and c' as centres. Draw dotted lines to cut these arcs, parallel to the horizontal centre line, from B and D to obtain ordinates.

Draft the quarter-pattern for the tapered piece in similar fashion to the last example. Note, however, that the true length $x-Y$ in the elevation is obtained by erecting a perpendicular to $x-Y'$ from Y' , equal in length to ordinate $Y-Y'$. Points A, b , c , d , and E are measured off on the edge line of the quarter-pattern similar to the points on the elevation edge line $x'-E$. Arcs $b-B$, $c-C$, and $d-D$ are the same length as the arcs from b , c , and d in the elevation, $c-C$, for instance, being equal to $c-C'$.

For the lay-out, ordinates B, C, and D—the heavy dotted lines—are measured off from 0 and 6 on the perpendicular and indefinite lines drawn from the points. The ordinates from the small end of the branch are also marked off from the same point and numbered as shown. There should be no difficulty in developing the half-pattern for the branch, as this is exactly the same procedure as for the previous example.

Chapter Nine

TWISTED AND OFF-SET TRANSFORMERS

AS explained in the first chapter on methods of pattern development, one of the difficulties of laying-out work from blue prints is that certain views which are considered necessary for pattern-drafting purposes are not given by the draughtsman. Much trouble is caused when tackling the patterns for off-centre and twisted air-duct transformers through the necessity of projecting additional plans and elevations from the given views of the plant lay-out. With the lay-out system, however, the views shown on the drawing can be used as a basis for obtaining the pattern true lengths. The whole procedure is thus very much simplified and valuable time saved.

FAN OUTLET CONNECTING PIECE

Fig. 32 shows a working drawing (minus the dimensions) of a connecting piece which transforms from the rectangular outlet of a fan to a round discharge pipe. This pipe lies at an angle to both the horizontal and vertical planes. No other view of the job is shown on the drawing, but if a plan were projected from the elevation it would show the fan outlet and pipe twisted to each other. This plan view is not necessary for development purposes if the elevation and end views of the job are shown.

In the drawing the centre lines of the duct are shown inclined to the base line in each view ; the angles are marked A and B respectively. These centre lines are the projected or "false" lengths of the true centre line of the duct. If desired, the true or resultant angle at which the pipe lies to the horizontal plane can be calculated by the following trigono-

metrical formula in which A is the elevation angle, B the end view angle, and θ the resultant angle.

$$\cot \theta = \sqrt{\cot^2 A + \cot^2 B}.$$

EXAMPLE.—Given that $A = 60^\circ$, $B = 70^\circ$,

then

$$\begin{aligned} \cot \theta &= \sqrt{\cot^2 A + \cot^2 B} \\ &= \sqrt{\cdot 5774^2 + \cdot 3640^2} \\ &= \sqrt{\cdot 465886 \dots} \\ &= \cdot 682 \dots \\ &= 56^\circ \text{ nearly.} \end{aligned}$$

It is not essential to know this angle for this particular pattern, but the formula has been included because it can be

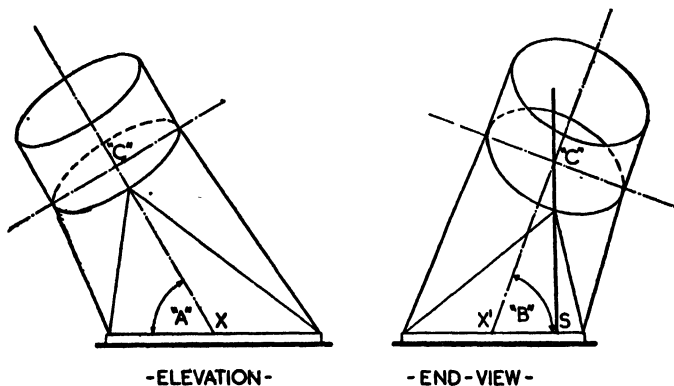

FIG. 32.

used to obtain the true angle for any kind of compound-angle duct work.

Before the pattern can be drafted it is necessary to draw an elevation showing a view of the transformer face on the vertical plane. In the working drawing the centre lines of the top are inclined to the base in both views, but if an elevation were drawn of the job with the top centre line parallel to the horizontal plane the elevation centre line "C"—X

would then be perpendicular to that plane. Fig. 33 shows a perspective view of the transformer placed in this position with a vertical plane cutting through the centre of the top face, parallel to the base edge A-B. The plane is placed in this way to illustrate a method by which a view of a section through the transformer is obtained. This section is projected

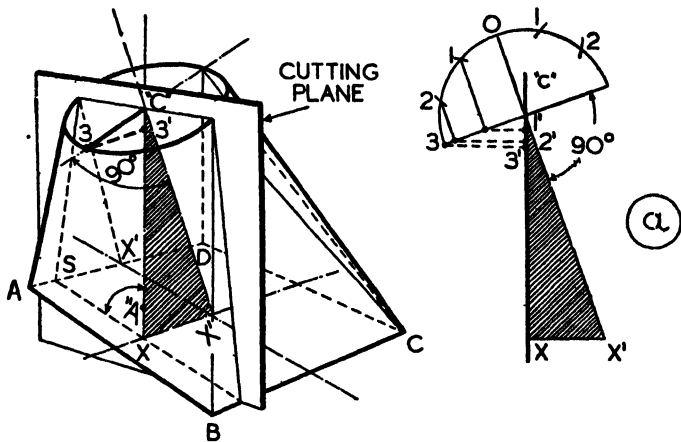

FIG. 33.

on to a vertical plane placed adjacent to the object, the lengths of the projectors being used to determine points in the lay-out construction.

On the cutting plane is shown the elevation centre line "C"-X. A line drawn on the top face from the edge point 3 to the centre "C" is inclined to the elevation centre line at an angle determined by the length of the centre line of the transformer. This true length is actually the hypotenuse of a right-angled triangle—shown shaded—of which "C"-X is the perpendicular and the end view offset distance the base. Point 3 on the top edge is projected to 3' on the plane. "C"-3' is the length of half the minor axis of an ellipse, of which the top diameter forms the major axis. This ellipse is the required view of the transformer face.

To obtain points on the ellipse for the elevation outline,

first draw, in a suitable position, a vertical line, as at Fig. 33 (a), and mark off on it "C"-X from the elevation on the working drawing. This line also represents the cutting plane edge. From X draw a horizontal line and make it equal to S-X' from the end view. Draw a line from X' through "C." Also through "C" draw an indefinite line at right angles to the hypotenuse and describe a semicircle on it, using "C" as centre, with a distance equal to the top face radius. Divide the semicircle into six equal parts and mark the points 0, 1, 2, and 3 as shown. Draw perpendiculars to the top edge line and project lines—shown dotted—horizontally to the cutting plane edge, to obtain points 1', 2', and 3'.

The ellipse is constructed on the top line 0-6 of an elevation drawn as shown in Fig. 34. This is a correct orthographic projection of the job on the vertical plane, showing the ellipse in its right relation to the true length A-B, but the ellipse can be drawn, if desired, on the top centre line of the elevation in Fig. 32, as the pattern can be correctly triangulated *by the lay-out system*, using this profile. The construction of a lay-out to obtain the true lengths of the elevation lines is very simple, as the positions in it of the vertical planes A-B and C-D in their relation to the cutting plane are determined by those distances on the end view base edge which lie each side of this plane. In actual practice the end view offset distance S-X' (Fig. 33) is added to half the base width, obtaining D-S, and then S-X' is deducted from the half-width, giving A-S. These two distances are marked off on the lay-out perpendicular from a point denoting the centre line 0-6 of the top face.

OBTAINING THE TRANSFORMER PATTERN

The construction required to obtain the pattern is as follows: First draw an elevation A-0-6-B, as shown in Fig. 34. Describe a semicircle on 0-6 and divide it into six equal parts, marking the points 1, 2, 3, etc. From the points draw lines of indefinite length through 0-6 and at right angles to this line. Next take the distance "C"-3' from Fig. 33 (a)

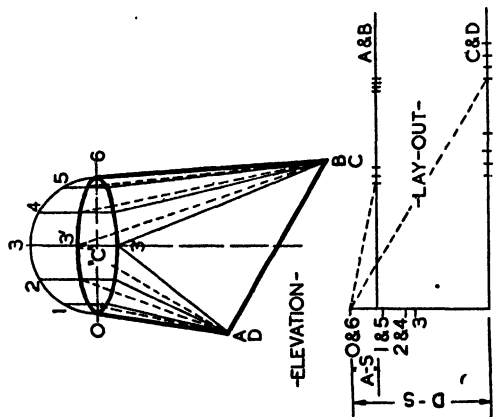
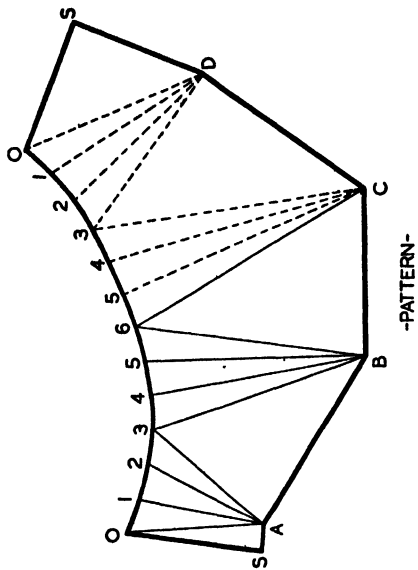

FIG. 34.

and mark it off each side of 0-6, using "C" as centre, on line 3. Similarly, take "C"-2' and mark it off on lines 2 and 4. Repeat this construction with "C"-1' on 1 and 5. Join all the points with a smooth curve to complete the ellipse. Next divide the elevation surface into triangles. Join the ellipse points to corners A and B as shown, drawing full lines for the front and dotted lines for the back of the transformer.

Now construct the lay-out in a convenient position. Draw a line for the common perpendicular of the triangles, mark a point 0 and 6 and measure from it the projectors from 1-1', 2-2', and 3-3' in Fig. 33 (a). These are the dotted lines between the inclined top line and the cutting plane edge. Number the points on the perpendicular 1 and 5, 2 and 4, and 3. Measure from 0 and 6 the base distances A-S and D-S. Draw horizontal lines from the points found and mark the lines A and B and C and D respectively.

To start the pattern, take the edge line 0-A from the elevation and draw it in a suitable position. As this is the seam, mark the top point 0 and the base point S. Next step 0-A along line A and B in the lay-out, measuring from the corner of the angle. Take the true length between the point marked and 0 on the perpendicular and describe an arc from 0 on the seam. Using S as centre, cut this arc in A with the base distance A-S from the end view or lay-out perpendicular. Take the false length 1-A, that is, the full line between A and the nearest point on the ellipse in the elevation, and measure it along lay-out line A and B. Join to 1 on the perpendicular and describe an arc with the true length from A in the pattern lay-out. Cut this arc in 1 with the spacing 0-1 from the elevation semicircle, using 0 as centre. Measure the false length 2-A along A and B in the lay-out and triangulate to 2 on the perpendicular. Add this true length to the pattern lay-out in similar fashion to the other true lengths, cutting it with spacing 1-2.

Continue the development on these lines for the front triangles of the job. The elevation edge line 6-B has its true length placed in the pattern to form one side of the end triangle B-6-C. To obtain the true length of 6-C, measure the edge

line along line C and D in the lay-out and join to 6 on the perpendicular. Describe an arc from 6 in the pattern lay-out and cut it in C with the base width B-C, using B as centre. Build up the back triangles from the false lengths shown dotted in the elevation. Step each line in turn along C and D in the lay-out and triangulate to the appropriate perpendicular number. Place them in the pattern in the same manner as for the first triangles. The last triangle, D-0-S, has D-S made equal in length to D-S in the lay-out. Finally, join all the points on the top edge of the pattern with a smooth curve and the base points with straight lines.

As an alternative method the pattern can be triangulated from an end view of the transformer, with a top edge inclined to the base at an angle similar to that of the top edge at (a) in Fig. 33, but this calls for a slightly more complicated type of lay-out, so the elevation method is the more suitable for most jobs. Working from an elevation in conjunction with a lay-out constructed on the cutting plane principle makes possible the easy solution of many twisted transformer and transition piece problems once the system is clearly understood.

TWISTED TRANSFORMER WITH TOP INCLINED TO A SQUARE BASE

This duct, shown in Fig. 35, is similar to the previous problem with the exception that the transformer top and base are situated about the vertical centre line. The job twists from an inclined round pipe to a square base. In the elevation and end views the top centre lines are inclined to the horizontal plane, being at right angles to the centre line of the pipe. The vertical centre line in the end view can be considered as the edge of a cutting plane; the view of the inclined top face on this plane is found by the construction shown at Fig. 35 (a). In this view "C"-X is taken from the elevation and X-X' from the end view; this is the offset distance S-X'. At right angles to the hypotenuse is drawn an indefinite line through "C." From "C" are marked off ordinates taken from a semicircle drawn on the elevation line 0-6, giving points 1, 2, and 3. Projectors from these points are drawn to

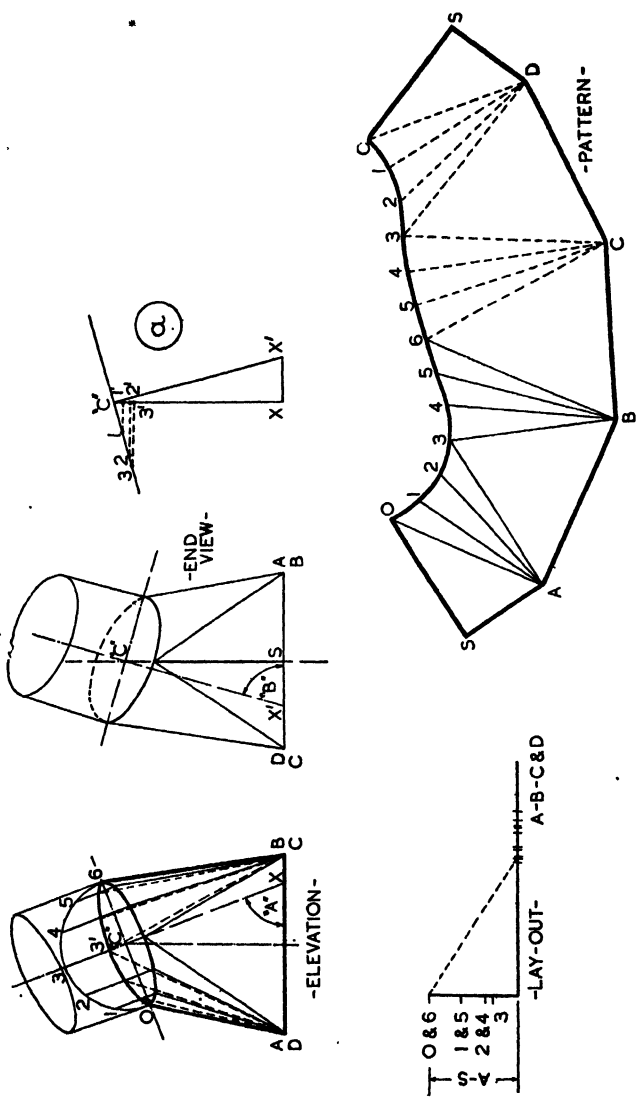

FIG. 35.

"C"-X, giving points 1', 2', and 3'. The distances "C"-1', etc., are used to construct the elevation ellipse, as explained for the previous example. For the lay-out construction the projector lengths 1-1', 2-2', and 3-3' are marked off from 0 and 6 on the lay-out perpendicular. Also from 0 and 6 is measured the half-base width A-S, and a line, perpendicular to the first, drawn from the point and marked A, B, C, and D. The pattern is drafted in the usual manner by obtaining the true lengths of the elevation lines on the lay-out and using

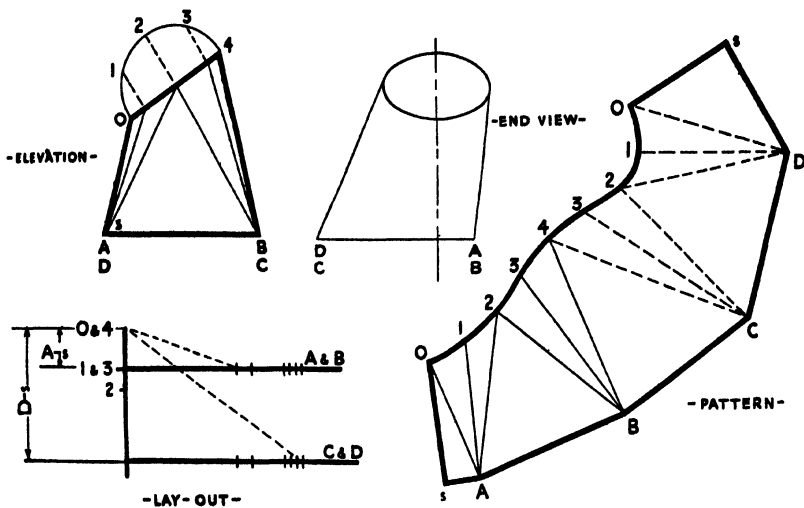
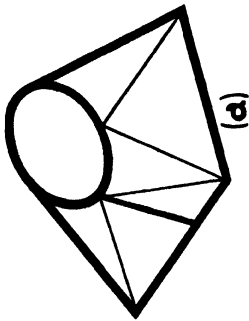

FIG. 36.

these to construct the pattern triangles in conjunction with the transformer top edge spacings and base distances.

An alternative method of tackling a twisted surface problem is shown in Fig. 40, Chapter Ten. This method can be applied, if desired, to those cases where an end view or plan of the job is shown by the draughtsman in a different position to the examples already given. To the craftsman who can read working drawings and has a fair knowledge of geometry, little difficulty should be experienced in adapting the methods described in this work to the solution of this type of problem however set-out on the blue print.



(a)

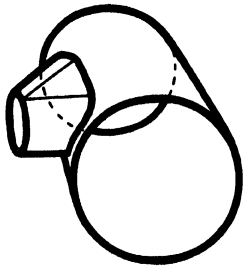

(b)

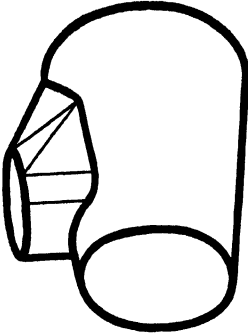

(c)



(d)

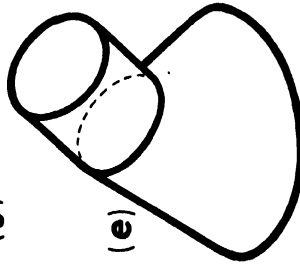

(e)

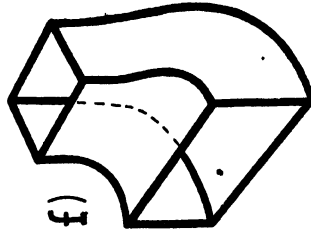

(f)

(a) Off-set Transformer, p. 82.

(b) Off-centre Shoe, p. 86.

(c) Shoe Fitted to Conical Connecting Piece, p. 88.

(d) Petrol Measure Top, p. 89.

(e) Hood Twisted to Outlet Pipe, p. 91.

(f) Rectangular Transition Bend, p. 92.

OFF-CENTRE TRANSFORMER

In the problem illustrated in Fig. 36 the inclined round face of the transformer top is off-centre from its rectangular base. The vertical centre line in the end view can be assumed to be the edge of a cutting plane, and base distances each side of it are marked off in the lay-out, as explained for the example shown in Fig. 34.

The construction of the lay-out and drafting of the pattern should entail little trouble, the full lines in the pattern being those on the front of the transformer, and they are obtained from the lay-out horizontal line A and B, while the dotted lines are on the transformer back; these true lengths are derived from C and D line in the lay-out.

Chapter Ten

MISCELLANEOUS PROBLEMS

THE examples now to be described have several points of interest which show the adaptability of the lay-out system to the solution of various kinds of development problems.

Fig. 37 depicts the setting-out required for an air-duct connecting piece or shoe, fitting off-centre on to a round main. It will be seen from a study of the elevation that the job essentially consists of the intersection of a transformer of irregular shape with a cylinder. Before the patterns can be obtained the joint line between the parts must be found in the following manner :—

SETTING-OUT FOR OFF-CENTRE SHOE

First set-out an elevation and draw a half-section of the transformer base on the cylinder centre line, as shown. Divide each of the semicircular ends into two equal parts and draw perpendiculars to the centre line. Next describe a semicircle on the transformer top, divide it into four equal parts and draw in ordinates to the edge line. Connect the top and base edge points with straight lines as shown. Draw an end view, describe a semicircle on the top edge, and divide it into four equal parts. Number the points 0, 1, 2, 3, and 4 and draw perpendiculars to the top edge. Produce these lines to cut the cylinder circumference at points *Bb*, *Cc*, and *Dd*.

Now project all the points on the end view joint line across horizontally to the elevation to cut the lines previously drawn on the transformer surface at points *A*, *B* . . . *b*, *a*. Connect these points to obtain the required joint line. Next find the shape of the hole in the main pipe. Erect a vertical line in a

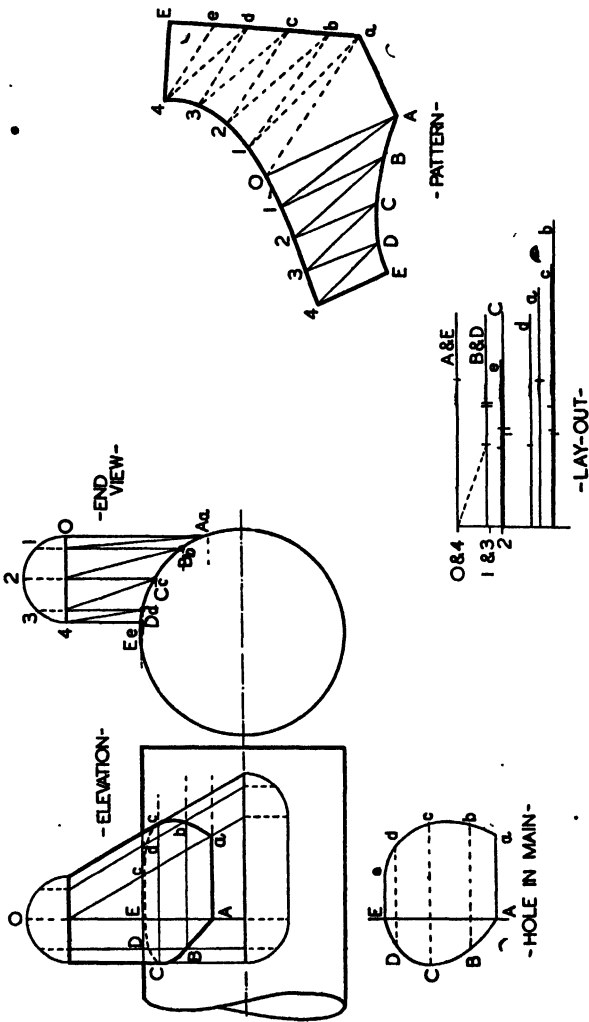

Fig. 37.

convenient position and mark off on it spacings $Aa-Bb$, $Bb-Cc$, $Cc-Dd$, and $Dd-Ee$ from the end view. Draw horizontal lines of indefinite length through the points. Make $a-A$, $b-B$, etc., equal in length each side of $A-E$ to the similar lettered lines in the elevation. Join up the points to obtain the perimeter of the hole, which is the true length of the joint line between the connecting piece and the main. The pattern for the shoe can be triangulated from the end view in the usual manner. To construct the lay-out draw a vertical line, mark a point 0 and 4, and step off distances 1 and 3 and 2 equal in length to the top-edge ordinates. Draw a horizontal line from 0 and 4 and letter it A and E . From 0 and 4 step off on the perpendicular the distances from the hole which lie each side of $A-E$, and draw horizontal lines from the points. Letter them as shown. Note that ordinates B and D are the same length in this example, thus the appropriate lay-out line is marked B and D .

No difficulty should be experienced in developing the pattern by obtaining the true lengths in the lay-out of all the lines drawn on the shoe surface in the end view. Each line actually represents two lines in the pattern. False length $2-Cc$, for example, is first stepped off on lay-out line C , and triangulated to 2 on the perpendicular to obtain $2-C$ in the pattern. Later in the development it is used again by marking it off on lay-out line c and measuring the distance to 2 on the perpendicular to find pattern line $2-c$. It is important to note that the spacings $E-D$, $D-C$, etc., in the pattern are taken from the hole perimeter and not from the elevation joint line.

SHOE FITTED TO CONICAL CONNECTING PIECE

In Fig. 38 the conical duct has a shoe fitted at right angles to its centre line, as shown. To find the joint line, strike arcs from the cone centre in the half-end view with distances $b-b'$, $c-c'$, and $d-d'$ from the elevation (section line $d-d'$ is drawn in any suitable position). These arcs are intersected at B , C , and D with the shoe edge line and a line drawn parallel to it from 1. Draw horizontal lines from the points to cut the elevation section lines at B , C , and D .

The lay-out is quite simple, as the horizontal lines are drawn from points 0 and 4, 1 and 3, and 2. Reference to the problem given in Fig. 31 should make the drafting of the

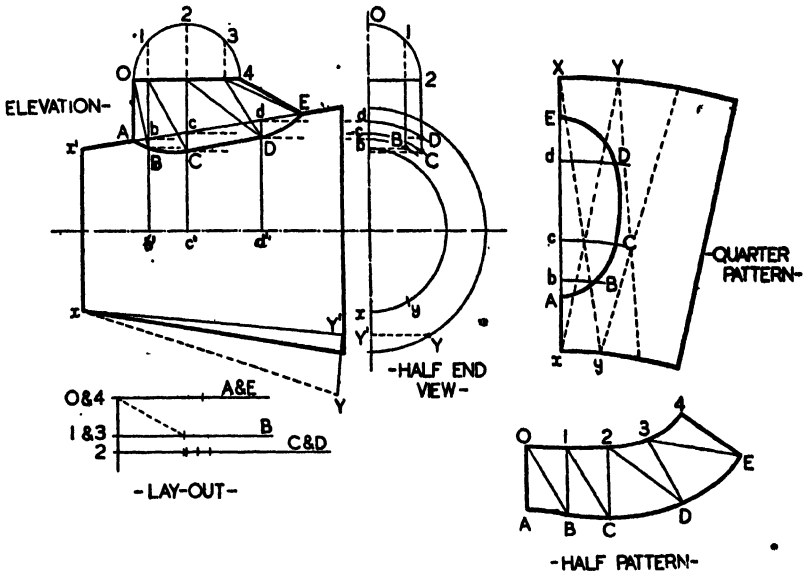

FIG. 38.

quarter-pattern for the cone frustum clear, the shoe half-pattern being perfectly straightforward to develop.

PETROL MEASURE TOP

This problem, as illustrated in Fig. 39, has a shaped top, the true perimeter of which is found by measuring off distances A-b, b-c, etc., along a straight line as at (a), erecting perpendiculars from the points and cutting these off the same length as ordinates B, C, D, E, and F on A-G. The spacings A-B, C-D, etc., at (a) are those used for the pattern. Part of this is slightly different to develop from previous problems. When finding the true length of D-K mark it along lay-out line K and triangulate to the point on the perpendicular made

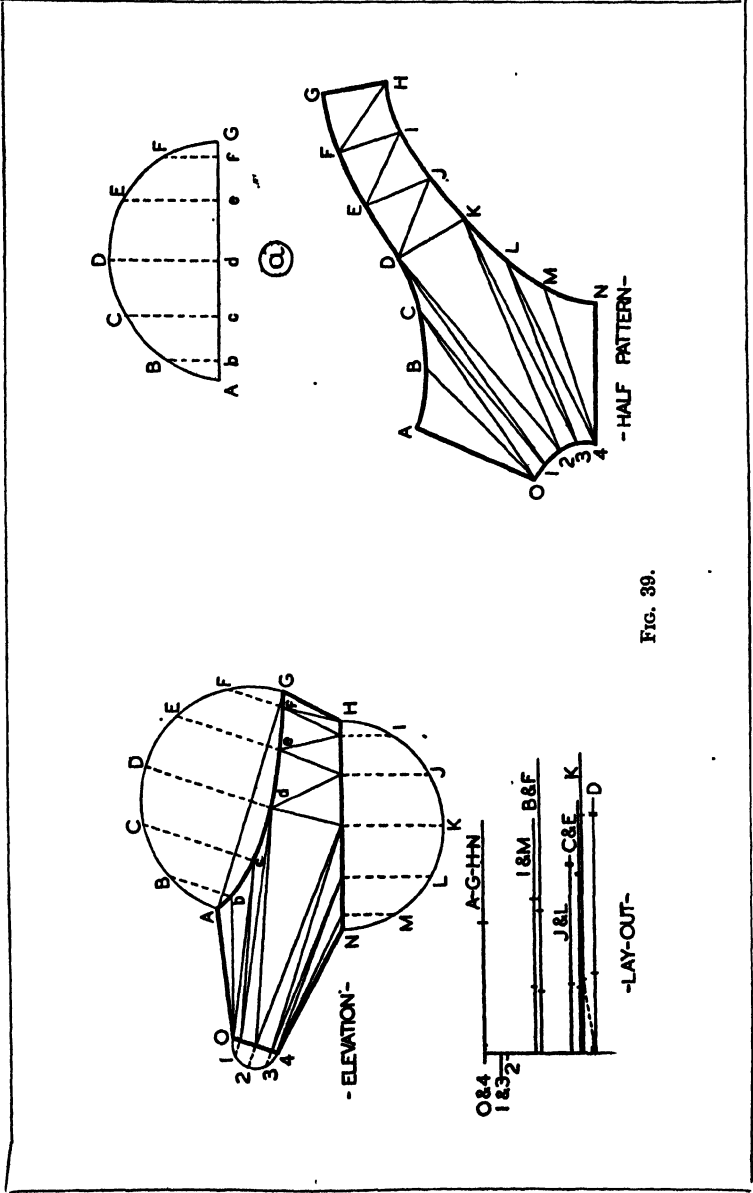

FIG. 39.

by the line D. Repeat this procedure for the remaining lines on this part of the job.

ELLIPTICAL HOOD TWISTED TO OUTLET PIPE

In this example, shown in Fig. 40, the end view vertical line a -A is divided into six suitable parts and horizontal lines drawn through the points across the end view surface to give points B, C, D, etc., on the perimeter. The lay-out is constructed as shown, the distances from θ and ϕ being the same as those which lie between vertical line a -A and the points on the ellipse perimeter. It will be observed that ordinate B is equal in length to ordinate f , C equal to e , and so on.

The construction of the lay-out and drafting of the pattern is on similar lines to previous examples. The outlet pipe is marked out by parallel-line development.

RECTANGULAR TRANSITION BEND

The final example depicted in Fig. 41 is of a transition bend between two rectangular ducts of different size. An end view of the job is first drawn, and it is used as the pattern for the flat side or cheek, in addition to being used as a basis for triangulating the twisted-end pattern. The surface of the end view is divided up into a suitable number of triangles, and points 1', 2', 3', B', C', and D' projected horizontally across to an elevation drawn as shown to obtain distances D-D', C-C', etc. It is necessary to use the parallel-line method of development to draft the back and throat patterns. For the back pattern the stretch-out line A' . . . E' is made equal in length to the curve A' . . . E' in the end view. Perpendiculars drawn from points A', B', etc., are made equal in length to the distances A-A', B-B', etc., in the elevation.

The throat pattern is obtained similarly. For the twisted-end pattern it is necessary to construct a lay-out by drawing a vertical line, marking a point A' and measuring from it distances 0-0', 1-1', etc., from the elevation or throat pattern, marking the points 0, 1, 2, and 3. From A' is also measured off distances A-A', B-B', etc., from either the back pattern or elevation and horizontal lines drawn from the points and

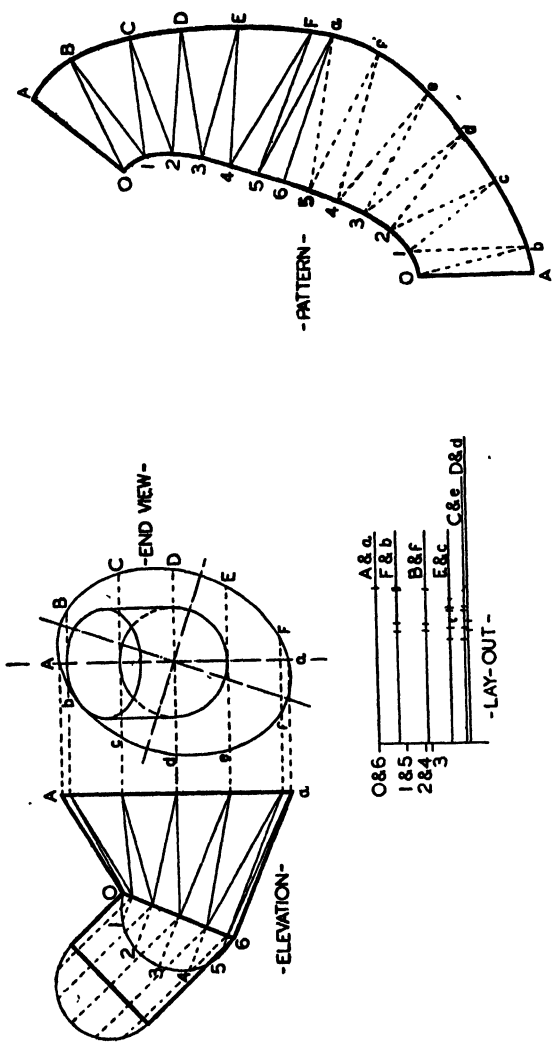

FIG. 40.

lettered B, C, and D respectively. The twisted-end pattern is triangulated from the end view by obtaining the true length lines in the lay-out and building up the pattern triangles with

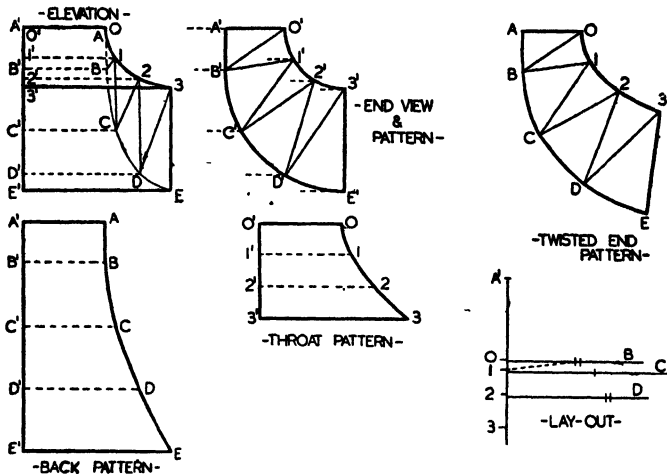

FIG. 41.

them in conjunction with the spacings from the curved lines in the throat and back patterns.

It is obvious that there are innumerable examples which could have been included in this work, but the author feels confident that sufficient information has been given to solve the most complicated problems to those who have understood the principles of the lay-out system of triangulation.

Chapter Eleven

ALLOWANCES FOR METAL THICKNESS

SHEET METAL patterns developed by geometrical methods are rarely very accurate, and a certain amount of arithmetic must be used to enable suitable adjustments to be made to the templates before they can be put into service. This procedure is particularly important when setting-out patterns for aircraft work where fine limits are called for on the working drawings.

Unless the metal used for the job is of very light gauge, allowances for material thickness must be taken into consideration when laying-out patterns. The principle on which metal thickness allowances are calculated is that of the "mean line" whereby the middle line of the metal is assumed to have not changed its length when the job is shaped and bent; this length, when obtained, is the required "stretched-out" length of the work in the flat sheet.

In Fig. 42 at (a) is shown a cylinder, the end view of which

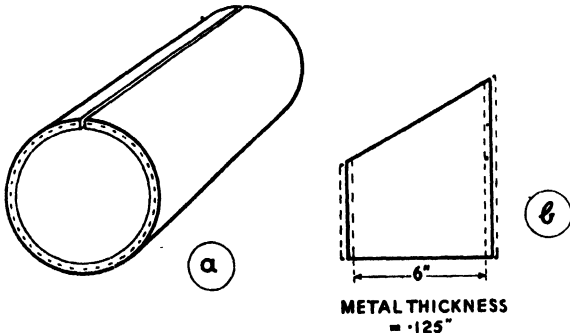

FIG. 42.

depicts the mean or centre line of the metal thickness. The length of this dotted line can be calculated by obtaining the

measured off as shown. In actual practice it is the best plan when laying out a drawing to draw all edge lines in the positions which would be occupied by the mean lines in a fully dimensioned drawing as executed by a draughtsman.

Referring to Fig. 43, it would be necessary to draw the cone base line 6.064 in. long on the metal and the top edge line 3.436 in. long, thus obtaining the right positions for the slanting edge lines. This ensures the correct length for the pattern generator line when the edge lines are produced to an apex. If all drawings are set-out on this principle and the pattern girth lines checked by calculation of circumferences, etc., and increased in length if necessary, no difficulty should be experienced in obtaining really accurate patterns.

SQUARE AND RECTANGULAR WORK

To obtain the patterns for square or rectangular work, such as are used for ducts, it is often necessary to make allowances for the pipe ends to slip into each other to enable a riveted

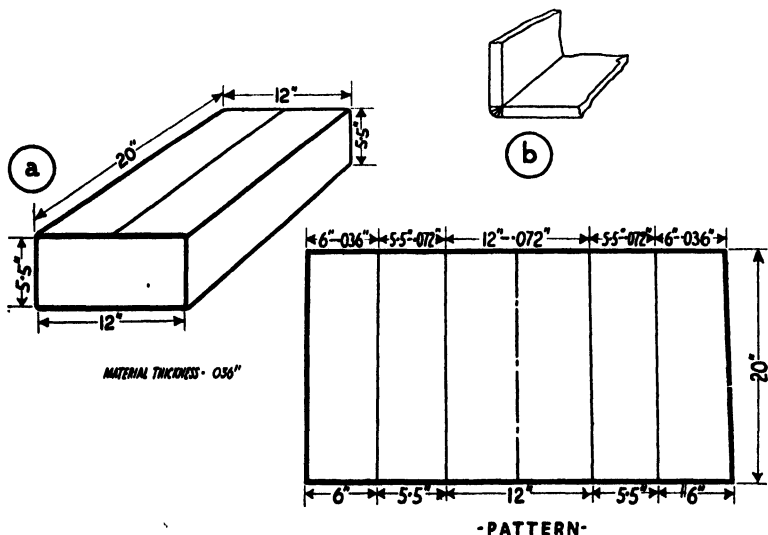

FIG. 44.

or spot-welded seam to be made. The sides of the job, as shown in Fig. 44 (a), are folded up at right angles with fairly

sharp inside corners. This means that no allowances for material thickness have to be made when working to inside dimensions because the metal stretches when it is folded, as shown by the shaded lines at Fig. 44 (b).

For the inside dimensions of the large end of the duct the measurements are marked off on the pattern base line, each side of the vertical centre line. The small or slip-in end of the pattern must have twice the thickness of metal deducted from each of the sides to give the required outside dimensions when the job is folded up. A careful study of Fig. 44 should make the whole procedure clear.

BENDING ALLOWANCES

The patterns for aircraft detail fittings and similar jobs have to be very accurately developed, therefore "rule-of-thumb" methods are completely out of place in the modern factory. By using the principle of the mean line it is possible to mark out templates for work which must be made to fine limits. No sharp bends are allowed in aircraft work, and unless otherwise shown by the draughtsman it is the general rule to make all jobs such as brackets, clips, etc., with a bend inside radius of twice the thickness of metal.

To obtain the developed length of the fitting on the flat sheet it is necessary to find the length of the mean line by calculating the lengths of the flat portions and the bends separately. The stretched-out length of the bend, called the bend allowance, can be found by the following formula:—

$$\text{Bend allowance} = \text{mean radius of bend multiplied by} \\ \text{bend angle multiplied by } \cdot 01745.$$

This formula can be applied to any type of bend, as it has been tried and proved on innumerable occasions in actual practice.

In Fig. 45 (a) is illustrated a right-angle bracket made of 16 gauge ($\cdot 064$ in.) metal. To obtain its development, first find the length of flat x . Deduct $3G$ —three times the metal thickness—from $2\cdot 25$ in., which gives the required dimension as $2\cdot 058$ in. The bending allowance is the mean radius

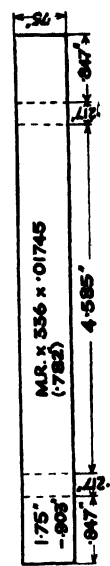
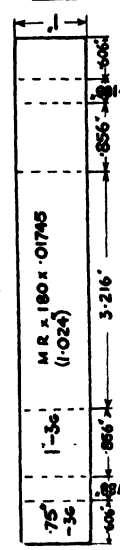
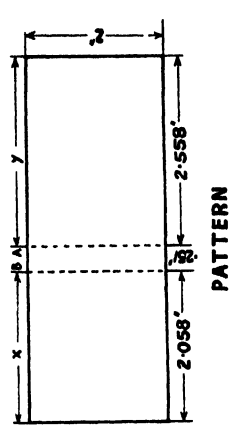
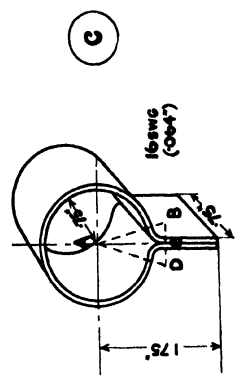
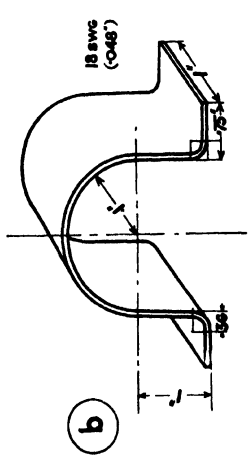
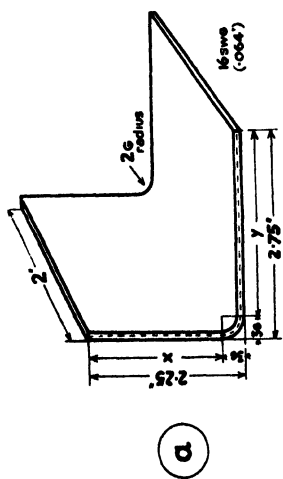

FIG. 45.

$(2G + \frac{1}{2}G)$ multiplied by 90 (the number of degrees in the bend angle) multiplied by $\cdot 01745$. The B.A., or length of the bend mean line, is thus $\cdot 251$ in. Flat y is $2\cdot 75$ in. $- 3G$, which is equal to $2\cdot 558$ in.

DEVELOPMENT OF PIPE CLIP

The clip shown at Fig. 45 (b) is made of 18 gauge metal. Essentially it is comprised of two similar right-angle brackets and a semicircular bend. Calculate the length of the bracket mean line by the method explained for the previous example. As there are 180° in the semicircular bend, the B.A. for this is found as follows :—

$$\begin{aligned} \text{B.A.} &= \text{M.R.} \times 180 \times \cdot 01745 \\ &= 1 \text{ in.} + \frac{1}{2}G \times 180 \times \cdot 01745 \\ &= 1\cdot 024 \text{ in.} \times 180 \times \cdot 01745 \\ &= 3\cdot 216 \text{ in.} \end{aligned}$$

No further explanation should be necessary, if the diagram is carefully studied, to draw the full development on the flat sheet.

DEVELOPMENT OF TUBE FITTING

The fitting illustrated at Fig. 45 (c) is rather more difficult to develop, because the bend angles cannot be easily recognised, as in the case of the previous examples. To find the correct angles it is necessary to use trigonometry. Referring to the diagram it will be seen that the small bends are separated from the large bend by lines which join the radius points of the bends. These lines form the isosceles triangle B-A-D.

The number of degrees in angle B can be found by raising a perpendicular from C to form the right-angled triangle B-A-C, of which the lengths of the hypotenuse A-B and the base B-C can be determined from the working drawing ; B-C divided by A-B is the cosine of the angle.

To obtain the length of A-B add the inside radius of the large bend to the outside radius of the small bend. B-C is $3G$ in length. In the example the hypotenuse and base are

·942 in. and ·192 in. in length respectively ; thus the cosine of the required angle is ·203 or 78° (nearly).

The B.A. for the small bends are :—

$$\begin{aligned} \text{B.A.} &= 2\frac{1}{2}G \times 78 \times \cdot 01745 \\ &= \cdot 160 \times 78 \times \cdot 01745 \\ &= \cdot 217 \text{ in.} \end{aligned}$$

To find the number of degrees in the large bend, first obtain angle B-A-C by deducting 78° from 90°. This gives 12°, which figure is doubled to obtain the top angle of the isosceles triangle : 24° is deducted from 360° to give 336° as the large bending angle. The B.A. for this bend is :—

$$\begin{aligned} \text{B.A.} &= \text{M.R.} \times 336 \times \cdot 01745 \\ &= \cdot 75 + \cdot 032 \times 336 \times \cdot 01745 \\ &= 4\cdot 585 \text{ in.} \end{aligned}$$

Next obtain the length of the flat portions. First find the length of A-C as follows :—

$$\tan 78^\circ = \frac{A-C}{\cdot 192} = \cdot 903 \text{ in.}$$

Finally, deduct ·903 in. from the given dimension 1·75 in. to obtain ·847 in. as the length of each flat.

All the foregoing principles can be applied to the solution of any development problem in which it necessary to make accurate allowances for the thickness of sheet metal.

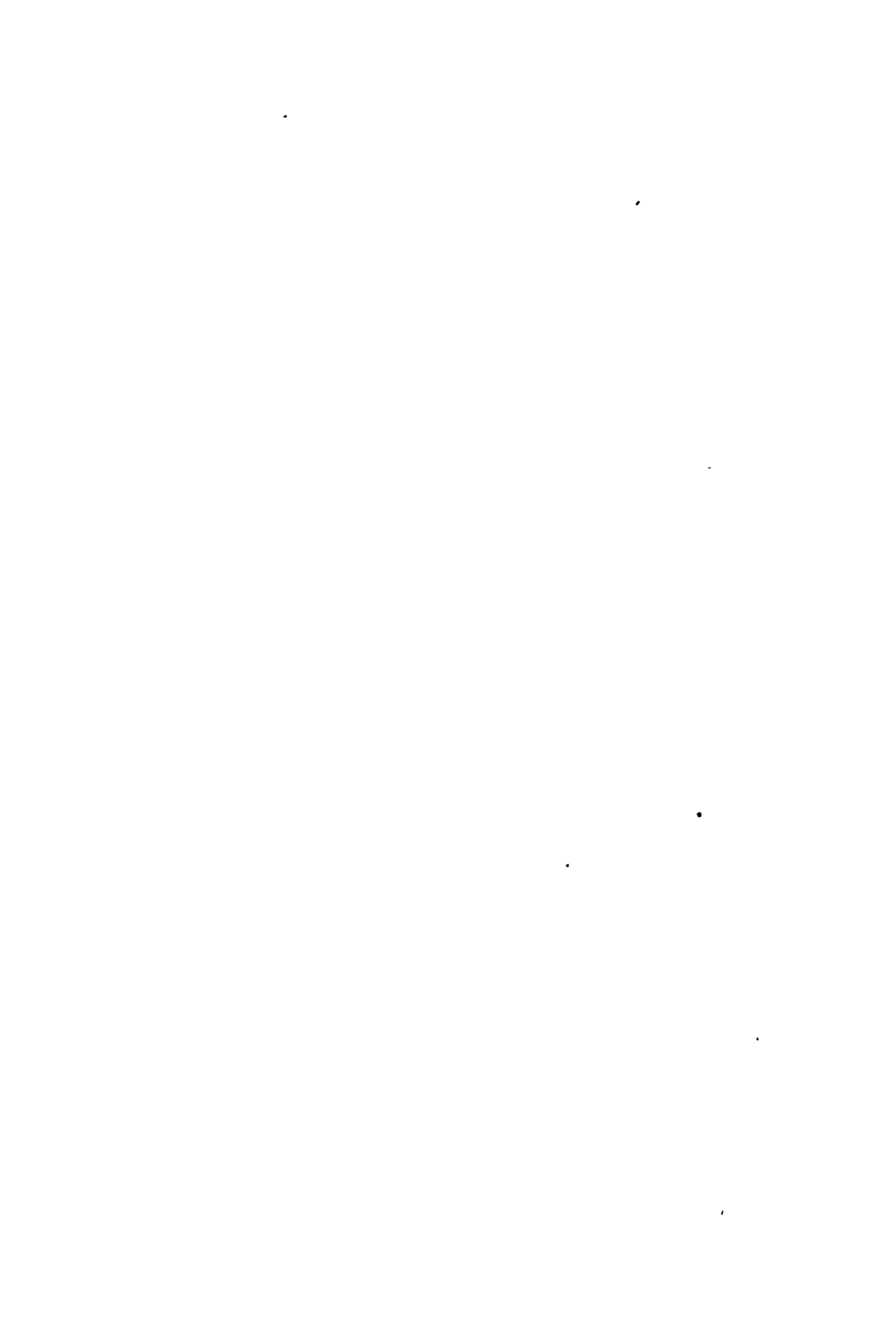

INDEX

A

- Adaptability of triangulation, 3
- Aircraft detail fittings, 96, 98
- Air-duct work, 1, 29
- Allowances, bend, 96
- Alternative design for three-way piece, 53
 - lay-out, description of, 41
 - method for transformer, 80, 82
- Auxiliary projection, 1

B

- Bend allowances, 96
 - rectangular transition, 90
- Branch connection, conical, 57, 65, 70
- Breeches piece, circular inlets to a circle, 30
 - — design, 29
 - — flush-sided, 38
 - — — with parallel ends, 42
 - — shaping up, 35

C

- Cone and cylinder, 56, 58
- Cone frustum, right, 7, 19, 27, 94
- Cones, oblique, 29
- Conical branch connection, 57, 65, 70
 - hopper on inclined pipe, 60, 62
 - pipe connections, 66
- Connecting piece, fan outlet, 74
 - — setting-out for, 22
 - — shoe fitted to, 87
- Circular inlets to circle breeches piece, 30
- Cutting plane, method of, 65
 - — use of, 76
- Cylinder, development of, 93
 - and transformer intersection, 85

D

- Description of alternative lay-out, 41
- Design of breeches piece, 29
- Detail fittings, aircraft, 96, 98

- Development of cylinder, 93
 - of pipe clip, 98
 - of tube fitting, 98

E

- Easier method of setting-out, 62, 70
- Elbow, two-way transition, 46

F

- Fan outlet connecting piece, 74
- Flush-sided breeches piece, 38
 - — — with parallel ends, 42
- Folding patterns, 54
- Formula, trigonometrical, 75
- Frustum of cone, 7, 19, 27, 94

H

- Hood twisted to outlet pipe, 90
- Hopper, conical on inclined pipe, 60, 62

I

- Intersection, cone and curve, 65
 - — and cylinder, 56
 - cylinder and transformer, 85
 - line of, 65

J

- Joints, slip-in, 25
- Junction piece, two-way, 49
 - — three-way, 33, 51, 53
 - pieces, multiple, 33
 - — special types of, 38, 49

L

- Lay-out, procedure for, 14, 21
- Line of intersection, 65
- Lobster-back bend, tapered, 23

M

- Material schedule, 1
- Mean-line method, 93
- Method for transformer, alternative, 80, 82
 - of cutting planes, 65
 - of mean line, 93
 - of parallel lines, 3
 - of radial lines, 6
 - of triangulation, standard, 8
- Multiple junction pieces, 33

O

- Oblique cones, 29
- Off-centre shoe fitted to round main, 85
 - transformer, 84
- Outlet pipe, hood twisted to, 90

P

- Parallel-line method, 3, 48, 90
- Pattern for round pipe cut obliquely, 5
 - for tee-piece of equal diameter, 5
- Patterns, folding, 54
 - from working drawings, 1
- Petrol measure top, 88
- Pipe clip, development of, 98
 - connections, conical, 66
- Procedure for lay-out, 14, 21
- Projection, auxiliary, 1

R

- Radial-line method, 6, 29, 56
- Rectangular transition bend, 90
 - and square work, 95
- Right cone frustum, 7, 27, 94
- Round pipe cut obliquely, pattern for, 5

S

- Schedule, material, 1
- Segments, welded, 25

- Setting-out, an easier method of, 62, 70
 - for connecting piece, 22
- Shape of shoes, 58
- Shaping-up breeches piece, 35
- Shoe fitted to round main, off-centre, 85
- Shoes, shape of, 58
- Slip-in joints, 25
- Special types of junction pieces, 38, 49
- Square and rectangular work, 95
 - to round transformer, 12
- Standard method of triangulation, 8

T

- Tapered lobster-back bend, 23
- Tee-piece of equal diameter, pattern for, 5
- Three-way junction piece, 33, 51, 53
 - — — alternative design for, 53
- Top, petrol measure, 88
- Transformer, off-centre, 84
 - square to round, 12
 - twisted to base, 74, 80
- Transition elbow, two-way, 46
- Triangulation, adaptability of, 3
 - method of, 8
 - standard method of, 8
- Trigonometrical formula, 75
- Twisted transformer to base, 74, 80
- Tube fitting, development of, 98
- Two-way piece, rectangular to round, 49
 - — with unequal branches, 54

U

- Unequal branches, two-way piece with, 54
- Use of cutting plane method, 76

W

- Welded segments, 25
- Work, air-duct, 1, 29
- Working drawings, patterns for, 1

PRACTICAL BOOKS

SHEET-METAL WORK

A Textbook for Draughtsmen, Apprentices, &c. By W. COOKSON and A. BOLD. 128 pages. 117 Illustrations.
Net 6s. 6d.

SHEET-METAL WORKER'S INSTRUCTOR

Comprising Geometrical Problems and Practical Rules for Describing the Various Patterns required by Zinc, Sheet-iron, Copper and Tin-plate Workers. By R. H. WARN. New Edition, Revised, by J. G. HORNER *Net 6s. 6d.*

OXY-ACETYLENE WELDING PRACTICE

A practical presentation of the modern process of Welding, Cutting, and Lead Burning, with special attention to Welding Technique for Steel, Cast Iron, Aluminium, Copper, and Brass. By R. J. KEHL. 104 pp. 111 Illustrations *Net 9s.*

PRESS TOOL-MAKING

A Practical Manual. Including Hardening and Tempering. By ERNEST PERRY. 80 pp. 32 Illustrations *Net 3s. 6d.*

JIGS, TOOLS, AND FIXTURES

Covering the Design of Equipment for practically all Modern Machine Tools. By PHILIP GATES. 220 pp. 168 Illustrations. 22 Tables *Net 10s.*

ENGINEERING WORKSHOP MANUAL

For Fitters, Turners, and General Machinists. Containing Practical Information on the Micrometer, Vernier, Tools, Screw-Cutting, Workshop Arithmetic, Geometry, Mensuration, Gear-Cutting, Precision Grinding, and General Machine Work. With Notes, Rules, and Tables. Eighth Edition, Revised and Enlarged. By E. PULL, M.I.Mech.E., M.I.Mar.E. 258 pp., with 195 Illustrations and numerous Tables *Net 4s. 6d.*

PATTERN MAKING

Embracing the Main Types of Engineering Construction. By J. G. HORNER, A.M.I.M.E. Sixth Edition. Revised and Enlarged by P. GATES. 400 pages. Over 600 Illustrations.
Net 16s.

METAL-TURNING

A Practical Handbook for Engineers. By J. HORNER, A.M.I.Mech.E. Fifth Edition revised by PHILIP GATES. 430 pp., with 488 Illustrations *Net 12s. 6d.*

LONDON

THE TECHNICAL PRESS LTD.

Late of 5 Ave Maria Lane, Ludgate Hill, and
19 Tavies Inn, Holborn Circus

DATE OF ISSUE

This book must be returned within 3/7/14 days of its issue. A fine of ONE ANNA per day will be charged if the book is overdue.

| | | | | | |
|--|--|--|--|--|--|
| | | | | | |
|--|--|--|--|--|--|

