

BIRLA CENTRAL LIBRARY

PAHARI (RAJASIHAN)

Call No. 665.5
1976
v. 3

Accession No. 7114d

*This book has been
graciously presented by
Birla Laboratories*

REFERENCE

CENTRAL LIBRARY

BIRLA INSTITUTE OF TECHNOLOGY & SCIENCE

Call No.

PILANI (Rajasthan)

Acc. No.

DATE OF RETURN

3/1/44

--	--	--	--

**THE
SCIENCE OF PETROLEUM**

VOLUME II

THE SCIENCE OF PETROLEUM

A COMPREHENSIVE TREATISE OF THE PRINCIPLES
AND PRACTICE OF THE PRODUCTION REFINING
TRANSPORT AND DISTRIBUTION OF
MINERAL OIL

DR. A. E. DUNSTAN

CHIEF CHEMIST OF THE ANGLO-IRANIAN OIL COMPANY, LTD.
LONDON

Managing Editor

PROFESSOR A. W. NASH

HEAD OF THE DEPARTMENT OF OIL ENGINEERING AND REFINING
THE UNIVERSITY, BIRMINGHAM, ENGLAND

Editor of Contributions

DR. BENJAMIN T. BROOKS

CONSULTING CHEMICAL ENGINEER, NEW YORK

Editor for the United States of America

SIR HENRY TIZARD, K.C.B., F.R.S.

RECTOR OF THE IMPERIAL COLLEGE OF SCIENCE AND TECHNOLOGY
LONDON

Consulting Editor

VOLUME II

OXFORD UNIVERSITY PRESS

LONDON NEW YORK TORONTO

1938

OXFORD UNIVERSITY PRESS
AMEN HOUSE, E.C. 4
LONDON EDINBURGH GLASGOW NEW YORK
TORONTO MELBOURNE CAPE TOWN BOMBAY
CALCUTTA MADRAS
HUMPHREY MILFORD
PUBLISHER TO THE UNIVERSITY

PRINTED IN GREAT BRITAIN

CONTENTS

VOLUME I

PART I

ORIGIN AND PRODUCTION OF CRUDE PETROLEUM

Sections 1-17

SECTION 1. NOMENCLATURE		3
Nomenclature of Crude Oil and its Products	R. SCHWARZ	4
The Nomenclature of Petroleum Products	A. W. NASH and F. C. HALL	7
Nomenclature of the Bitumens	P. E. SPIELMANN	15
SECTION 2. STATISTICS		19
Statistics of Petroleum and Allied Substances	G. SELL	20
SECTION 3. ORIGIN OF PETROLEUM		31
The Origin of Petroleum	V. C. ILLING	32
On the Origin of Petroleum	S. C. LIND	39
Petroleum Source Beds	P. D. TRASK	42
The Chemical and Geochemical Aspects of the Origin of Petroleum	B. T. BROOKS	46
Biochemical Aspects of the Origin of Oil	G. D. HOBSON	54
SECTION 4. DISTRIBUTION OF PETROLEUM		57
The Stratigraphical Distribution of Petroleum	W. A. J. M. VAN WATERSCHOOT VAN DER GRACHT	58
The Geographical Distribution of Petroleum	W. A. J. M. VAN WATERSCHOOT VAN DER GRACHT	63
Oil and Gas in the United States	W. A. VER WIEBE	66
Canada	G. S. HUMB	96
Geology of the Tampico-Tuxpan Oilfield Region	J. M. MUIR	100
Eastern Venezuela and Trinidad	V. C. ILLING and H. G. KUGLER	106
Colombia and the Maracaibo Basin	V. R. GARFIAS and T. CHAPIN	111
Ecuador	H. G. BUSK	118
The Argentine Republic	E. FOSSA-MANCINI	120
Australia	W. G. WOOLNOUGH	124
New Guinea	B. K. N. WYLLIE	130
The East Indian Archipelago	H. SCHUPPLI	131
Burma and Assam	G. W. LEPPER and P. EVANS	133
Lanywa Oilfield, Upper Burma	E. S. PINFOLD	137
North-West India	E. S. PINFOLD	138
China	F. G. CLAPP	139
The Geology of the Oilfield Belt of Iran and Iraq	G. M. LEES	140
The Structural Conditions of the Kirkuk Oilfield, Iraq	N. E. BAKER	149
Egypt	P. VAN DER PLOEG	150
Africa and Madagascar	G. D. HOBSON	152
U.S.S.R.	G. D. HOBSON	155
Roumania	G. D. HOBSON	167
Albania	S. ZUBER	172

Czechoslovakia	S. ZUBER	175
Poland	S. E. COOMBER	177
Germany	S. E. COOMBER	184
Italy	S. ZUBER	189
France	S. ZUBER	193
SECTION 5. MIGRATION OF PETROLEUM		197
The Measurement of the Permeability of Reservoir Rocks and its Application	G. L. HASSLER	198
The Migration of Oil	V. C. ILLING	209
SECTION 6. NATURAL ACCUMULATIONS OF PETROLEUM		217
An Introduction to the Principles of the Accumulation of Petroleum	V. C. ILLING	218
The Porosity of Reservoir Rocks	S. E. COOMBER	220
The Origin of Pressure in Oil-pools	V. C. ILLING	224
Shorelines and Lenticular Sands as Factors in Oil Accumulation	J. L. RICH	230
The Relationship of Buried Hills to Petroleum Accumulation	J. L. FERGUSON and J. VERNON	240
Location of Oilfields in Tectonic Belts	H. DE CIZANCOURT	244
Oilfields in Folded Rocks	W. A. J. M. VAN WATERSCHOOT VAN DER GRACHT	247
The Role of Faulting in the Accumulation of Oil and Gas	V. C. ILLING	252
Salt Structures: their Form, Origin, and Relationship to Oil Accumulation	G. D. HOBSON	255
Oil Accumulation in Igneous Rocks	E. H. SELLARDS	261
SECTION 7. GEOLOGICAL METHODS OF EXPLORATION		267
Historical Notes on the Development of the Technique of Pros- pecting for Petroleum	E. DE GOLYER	268
Maps	F. H. LAHEE	276
Aerial Reconnaissance	M. HOTINE	284
Surface Indications of Oil	S. E. COOMBER	291
The Significance of Surface Indications of Oil	V. C. ILLING	294
Nature and Significance of Sedimentary Volcanism	H. G. KUGLER	297
Application of Palaeogeology to Petroleum Geology	A. I. LEVORSEN	300
Stratigraphical Considerations	R. C. MOORE	304
Palaeontology	A. MORLEY DAVIES	306
Micro-palaeontology	W. L. F. NUTTALL	309
The Correlation of Sediments by Mineral Criteria	A. BRAMMALL	312
SECTION 8. GEOPHYSICAL METHODS OF EXPLORATION		315
Geophysical Methods—Introduction	A. S. EVE	316
Petroleum Geophysics	D. C. BARTON	319
Magnetic Methods	W. F. JENNY	328
Electrical Prospecting for Oil	C. SCHLUMBERGER	346
Electrical Coring	C. SCHLUMBERGER	351
Gravitational Methods of Prospecting	D. C. BARTON	364
The Refraction Method of Seismic Prospecting	J. H. JONES	382
Reflection Method of Exploring Subsurface Geology	B. MCCOLLUM	387
SECTION 9. METHODS OF DRILLING		399
Percussion Tool Pressure Drilling	M. C. SEAMARK	400
Present Trends in Rotary Well Drilling and Completion	I. F. BINGHAM	406
Special Alloys for Drilling Bits	H. W. FLETCHER	430

CONTENTS

vii

The Drilling and Control of High-pressure Wells	L. V. W. CLARK	433
Core Drilling	L. V. W. CLARK	439
Directed Drilling	L. V. W. CLARK	444
Rotary Drilling Fluids	H. A. AMBROSE and A. G. LOOMIS	448
The Mineralogical Constitution of Clays	G. D. HOBSON	460
Oil-well Cementing	C. P. PARSONS	463
Properties of Cements	S. G. S. PANISSET	476
Casing	B. B. WESCOTT	482
Tubing	B. B. WESCOTT	491
Sucker Rods	B. B. WESCOTT	494
SECTION 10. SAMPLING, CORING, AND BORE-HOLE SURVEYING		501
The Interpretation of Core Evidence	C. A. SANSON	502
Bottom-hole Pressure Measurement	L. A. PYM	508
Bottom-hole Temperature Measurement	M. W. STRONG	516
Bottom-hole Samples	D. COMINS	523
<i>(See also Electrical Coring by C. Schlumberger in Section 8 on Geophysical Methods of Exploration.)</i>		
SECTION 11. PRODUCTION		531
Proved Oil Reserves	V. R. GARFIAS and R. V. WHETSEL	532
Scientific Unit Control	H. S. GIBSON	534
Fundamental Principles Governing Drainage of Petroleum from its Reservoir Rocks	L. C. UREN	541
The Potential Oil Yield of Reservoir Rocks	A. J. HAWORTH	552
The Scientific Study of the Flow of Oil in Wells	C. J. MAY and E. S. L. BEALE	556
The Control of Water in Oil Reservoirs	H. D. WILDE and T. V. MOORE	568
Oilfield Repressuring	S. F. SHAW	577
Producing Oil with Gas-lift	S. F. SHAW	583
Oil-well Pumping	H. H. POWER	590
Oil-well Bailing	H. H. WRIGHT	600
Stage Separation of Crude Oil-Gas Mixtures	R. L. HUNTINGTON	606
Chemical Demulsification of Crude Petroleum	M. DE GROOTE	616
Electrical Dehydration of Crude Petroleum Emulsions	L. C. UREN	630
A Method of Working Petroleum by Means of Underground Drainage	P. DE CHAMBRIER	637
Mining for Asphalt	A. LEAMON BERRY	640
SECTION 12. OILFIELD WATERS		645
Methods of Analysis of Oilfield Waters	C. E. WOOD	646
The Interpretation of Oilfield Water Analyses	A. R. BOWEN	653
SECTION 13. POWER IN OILFIELD DEVELOPMENT		657
Steam Drilling Equipment	V. WEAVER WRIGHT	658
Internal-combustion Engines for Oilfield Drilling Practice	L. V. W. CLARK	667
General Electrification of Oilfields	D. H. MCLACHLAN	670
SECTION 14. THE MEASUREMENT OF OIL, GAS, AND WATER IN OILFIELDS		677
The Gauging and Measurement of Liquid Petroleum Products	H. MOORE	678
The Principles of Practical Orifice Metering	E. S. L. BEALE	688
The Measurement of Gas with Particular Reference to Natural Petroleum Gases	H. S. BEAN	704
Calibration of Tanks	A. W. COX	711

SECTION 15. CRUDE OIL TRANSPORT		717
The Laws of Fluid Flow in Pipelines	E. S. L. BEALE and P. DOCKSEY	718
The Flow of Waxy Oils and other Non-Newtonian Liquids	E. S. L. BEALE	734
Heat Loss from Buried Oil Pipelines	E. S. L. BEALE, A. C. HARTLEY, W. J. D. VAN DYCK, and W. R. VAN WYK	740
The Corrosion and Protection of Pipelines in the United States of America	K. H. LOGAN	747
Modern Pipeline Practice	W. G. HELTZEL	758
Design of Main-line Pumping Stations	H. A. HAMMICK	773
The Transport of Oil by Rail and Road	F. N. HARRAP	781
Principles of Design and Operation of Sea Terminals	G. C. CUNNINGHAM and R. D. WARD	785
The Modern Tanker	C. ZULVER	795
SECTION 16. NATURAL GAS TRANSPORT		803
Natural Gas Transportation	S. LEARNED	804
SECTION 17. STORAGE OF OIL AND GAS		811
Crude Gathering Systems	C. A. ANDREWS	812
Pressure Storage of Petroleum Products	H. C. BOARDMAN and L. V. W. CLARK	818
Floating Roofs	D. E. LARSON	825
Evaporation Losses of Petroleum and Gasoline	L. SCHMIDT	828
Effect of Tank Colours for Reducing Evaporation Loss from Crude Petroleum and Gasoline Storage Tanks	L. SCHMIDT	834

VOLUME II

PART II

CHEMICAL AND PHYSICAL PRINCIPLES OF THE REFINING OF MINERAL OILS

Sections 18-39

SECTION 18. NATURE OF CRUDE PETROLEUM		839
Mid-Continent	F. W. L. TYDEMAN and C. M. KELLOGG	840
California	D. R. MERRILL	851
Gulf Coast	A. J. KRAEMER	858
Canada	G. EGLOFF	866
Mexico	J. MCCONNELL SANDERS	868
Venezuela	R. J. FORBES	876
Trinidad	I. MCCALLUM	879
Argentina	R. J. FORBES	881
Colombia, Peru and Ecuador	G. EGLOFF	884
Japan	M. MIZUTA	886
Dutch East Indies	R. J. FORBES	888
Burma	W. J. WILSON	891
Iran	F. B. THOLE	894
Bahrein Islands	G. EGLOFF	895
Iraq	M. S. MAINLAND	896
Egypt	R. J. FORBES	898
U.S.S.R.	A. VELIKOVSKY	900

CONTENTS

		ix
Roumania	R. J. FORBES	918
Poland	J. EHRlich and A. SZAYNA	922
Europe and the East	G. EGLOFF	930
SECTION 19. CHEMISTRY OF PETROLEUM 935		
The Chemistry of Hydrocarbons	J. F. THORPE and E. H. FARMER	936
The Chemical Character of Petroleums and Petroleum Products	B. T. BROOKS	986
The Chemical Composition of Cracked Gasolines	J. C. MORRELL and G. EGLOFF	996
OXIDATION AND OXY-COMPOUNDS		
Naphthenic Acids, Oxy-compounds, &c.	J. VON BRAUN	1007
Gum in Gasoline	W. A. GRUSE	1016
Industrial Oxidation of Petroleum Hydrocarbons	A. W. BURWELL	1028
SULPHUR COMPOUNDS		
The Sulphur Compounds in Petroleum	E. EMMET REID	1033
The Sulphur Compounds of Bituminous Oils	F. CHALLENGER	1042
NITROGEN COMPOUNDS		
The Nitrogen Bases of Petroleum Distillates	J. R. BAILEY	1047
INORGANIC CONSTITUENTS OF PETROLEUM		
Inorganic Constituents of Petroleum	W. H. THOMAS	1053
COLLOIDICS		
Colloid and Capillary Chemistry of Petroleum	H. FREUNDLICH	1057
SECTION 20. PHYSICAL AND CHEMICAL PROPERTIES OF PETROLEUM AND ITS PRODUCTS: DETERMINATION, CORRELATION, AND COLLECTED DATA . 1069		
VISCOSITY		
The Viscosity Characteristics of Petroleum Products and their Determination	D. P. BARNARD	1071
Viscosity of Gases	E. S. L. BEALE	1080
Viscosity-Temperature Characteristics of Petroleum Products	W. R. WIGGINS	1083
Viscosity Index and Viscosity Gravity Constant	F. DOCKSEY	1091
Anomalous Viscosity	A. S. C. LAWRENCE	1099
The Measurement of Plasticity	A. de WAELE	1106
The Flow-Temperature Method of Determining the Action of Cold on Oils, Greases, and Lubricants, Derived from Petroleum	P. WOOG	1118
Viscosity and Pseudo-plasticity	H. WEISS and M. LOUIS	1125
DENSITY AND REFRACTIVE INDEX		
Density, Gravity, and Specific Gravity	D. W. GOULD	1129
Specific Gravity Correction Factors for Petroleum Oils	E. S. L. BEALE	1133
Correction of the Density and Refractive Index of Hydrocarbons for Temperature	E. S. L. BEALE and T. K. HANSON	1136
Determination of Density and Refractive Index of Hydrocarbons and Petroleum Products	A. L. WARD, S. S. KURTZ, JR., and W. H. FULWEILER	1137
General Relationship of Density, Refractive Index, and Related Characteristics, with Structure of Hydrocarbons	A. L. WARD, S. S. KURTZ, JR., and W. H. FULWEILER	1172
Density and Refractive Index of Crude Petroleum, Gasoline, Kerosine, Gas Oil and Fuel Oils	A. L. WARD, S. S. KURTZ, JR., and W. H. FULWEILER	1176

Density and Refractive Index of Paraffin Wax	A. L. WARD, S. S. KURTZ, JR., and W. H. FULWEILER	1187
Refractive Index of Paraffin Wax	C. R. SCOTT HARLEY	1191
SPECTROGRAPHIC AND X-RAY APPLICATION		
The Application of the Infra-red Absorption Spectra to the Study of Petroleum Oils and Spirits	J. LECOMTE	1196
The Application of the X-ray Method to the Study of the Paraffin Hydrocarbons	F. FRANCIS and S. H. PIPER	1203
The Application of the Raman Effect to Petroleum Chemistry	J. H. HIBBEN	1206
Analysis of Petroleum Spirits Using the Raman Spectrograph	A. ANDANT	1213
OPTICAL PROPERTIES		
Optical Activity and Its Significance	C. E. WOOD	1216
The Application of Magnetic Optical Properties in the Analysis of Hydrocarbon Mixtures	M. SCHERER	1220
THERMAL, CRITICAL, AND P-V-T. DATA AND THEIR MEASUREMENT		
Apparatus and Methods for Determining Thermal Properties of Petroleum Products	R. S. JESSUP	1224
Heat of Combustion of Petroleum Oils	D. W. GOULD	1233
Heats of Combustion of Hydrocarbon Gases	D. W. GOULD	1241
Combustion Data for Gaseous Fuels	E. S. L. BEALE and P. DOCKSEY	1243
Specific Heat and Heat Content of Petroleum Products	D. W. GOULD	1249
Latent Heat Data for Hydrocarbons, Petroleum Products, and Miscellaneous Substances	E. S. L. BEALE	1256
Thermal Conductivity of Gases, Vapours, and Liquids	E. S. L. BEALE	1261
P-V-T. Relationships of Hydrocarbons	P. DOCKSEY	1263
Determination of Critical Temperature and Pressure of Petroleum Fractions	L. C. ROESS	1270
Conversion of Boiling-points of Petroleum Fractions	E. S. L. BEALE	1280
PHYSICAL PROPERTIES AND MOLECULAR STRUCTURE		
Methods of Determining Vapour Pressure, Critical Point, and Vapour Density	O. MAASS and J. H. MENNIE	1287
Determination of the Molecular Weights of Petroleum Fractions	C. E. HEADINGTON	1295
The Properties of Pure Hydrocarbons	G. L. EATON	1302
The Physical Constants and Molecular Structure of the Non- cyclic Hydrocarbons	C. E. BOORD	1349
The Energy of Atomic Linkages in Hydrocarbons	J. P. WIBAUT	1357
The Dielectric Constant of Petroleum and Petroleum Pro- ducts	G. M. L. SOMMERMAN	1361
Interfacial Tension	H. WEISS and E. VELLINGER	1366
Interfacial Tension	A. S. C. LAWRENCE	1369
The Application of Physical Methods to the Analysis of Hydrocarbon Mixtures	M. L. I. T. AUBERT	1375
Correlation of the Physical Properties of Petroleum	K. M. WATSON	1377
SECTION 21. GENERAL ANALYSIS AND TESTING OF PETROLEUM PRODUCTS 1387		
The Laboratory Testing of Petroleum Products: Gasoline, White Spirit, Kerosine, and Gas Oil	A. W. NASH and F. C. HALL	1388
The Laboratory Testing of Lubricating Oils	A. W. NASH and F. C. HALL	1407
Methods for the Analysis of Fuel Oil	F. B. THOLE	1428
General Methods of Analysis of Waxes	W. J. WILSON and R. E. DOWNER	1433
Testing of Asphaltic Bitumen	J. S. JACKSON	1438

CONTENTS

xi

General Methods of Analysis of Transformer Oils	A. R. STARK	1443
Cable Oils	C. CHILVERS	1447
The Analysis of Greases and High-pressure Lubricants	C. A. FOSLER	1453
SECTION 22. HISTORY AND DEVELOPMENT OF REFINING		1465
History and Development of some Important Phases of Petroleum Refining in the United States	W. MILLER and H. G. OSBORN	1466
SECTION 23. CASING HEAD GASOLINE EXTRACTION		1479
Gasoline Recovery by Charcoal Adsorption	T. G. HUNTER	1480
The Recovery and Stabilization of Gasoline from Refinery and Natural Gases	P. D. BARTON	1483
SECTION 24. NATURAL AND REFINERY GASES		1499
The Composition of Natural Gas	A. R. BOWEN	1500
Helium	F. A. PANETH	1511
Occurrence and Production of Helium in the United States	R. R. BOTTOMS	1517
The Analysis of Petroleum Gases	H. M. STANLEY	1524
The Utilization of Liquefied Petroleum Gases	G. G. OBERFELL and T. W. LEGATSKI	1534
SECTION 25. DISTILLATION		1543
Separation of Petroleum Hydrocarbons by Distillation	G. GRANGER BROWN and M. SOUDERS, JR.	1544
Distillation in the Refining of Petroleum	W. A. PETERS, JR.	1580
Laboratory and Small-scale Distillation	M. R. FENSKE	1629
The Manufacture of White Spirits, Special Naphthas, and Petroleum Solvents, by Distillation	L. CLEMENT	1662

VOLUME III

PART II (continued)

SECTION 26. REFINING PROCESSES: PHYSICAL		1671
Adsorption	A. KING	1672
Treating Mineral Oils by Percolation and Contact Filtration	E. R. LEDERER and E. W. ZUBLIN	1679
Fuller's Earth Treatment of Cracked Gasoline	M. R. MANDELBAUM	1693
Acid-treated Clays	B. A. STAGNER	1699
SECTION 27. REFINING PROCESSES: CHEMICAL		1707
The Chemistry of the Refining of Light Distillates	S. F. BIRCH	1708
The Chemistry of Refining Processes (Lubricating Oil)	F. E. A. THOMPSON	1759
Sulphuric Acid Treatment	S. F. BIRCH	1769
Equipment for Chemical and Solvent Treating Operations	T. G. HUNTER	1779
Refining Cracked Naphtha with Sulphuric Acid at Low Temperatures	R. A. HALLORAN	1798
Sulphur Removal from Gases	A. R. POWELL	1804
Organic Amines—Girbotol Process	R. R. BOTTOMS	1810
SECTION 28. SOLVENT-EXTRACTION METHODS OF REFINING		1817
Theoretical Principles of Solvent Extraction	T. G. HUNTER	1818
The Application of Triangular Graphs to the Comparative Laboratory Study of Solvent-refining Processes	F. E. A. THOMPSON	1829
General Factors Affecting Solvent-extraction Processes	S. W. FERRIS	1875

Refining Kerosines by Extraction with Liquid Sulphur Dioxide—The Edleau Process	F. C. HALL	1888
Solvent Treatment of California Lubricating Stocks, particularly with Sulphur Dioxide, Sulphur Dioxide—Benzene	U. B. BRAY	1893
The Nitrobenzene Method	S. W. FERRIS	1904
Phenol Extraction of Lubricating Oils	R. K. STRATFORD	1910
The Chlorex Extraction Process	W. H. BAHLKE	1915
The Application of Furfural to the Refining of Lubricating Stocks	R. E. MANLEY and B. Y. MCCARTY	1918
The Duo-Sol Process	H. W. SHELDON and B. W. STORY	1924
SECTION 29. DEWAXING		1929
General Principles of Refrigeration	C. O. BROWN	1930
The Crystallization of Petroleum Wax	F. W. FADGETT	1941
Removal of Wax by Centrifuging	L. D. JONES	1945
The Filter Pressing of Wax Distillate and the Sweating of Slack Wax	F. W. FADGETT	1954
Dewaxing of Lubricating Oils by Benzol—Acetone Mixtures	L. C. STRANG	1962
Refining with Liquid Propane	U. B. BRAY and W. H. BAHLKE	1966
Principles of Dewaxing	T. G. HUNTER	1980
SECTION 30. GAS PYROLYSIS AND POLYMERIZATION		1993
Thermal Reactions of Gaseous Hydrocarbons	F. E. FREY and H. J. HEPP	1994
Pyrolysis of Gaseous Hydrocarbons	D. A. HOWES	2007
The Gaseous Paraffins as a Source of Olefines	D. A. HOWES	2030
Pyrolysis and Polymerization Processes for the Production of Liquid Fuels from Gaseous Hydrocarbons	D. A. HOWES	2045
SECTION 31. CRACKING		2077
A Brief History of Petroleum Cracking	B. T. BROOKS	2078
Thermochemistry of Petroleum Hydrocarbons	A. W. FRANCIS	2088
The Theory of Cracking	P. K. FROLICH and S. C. FULTON	2099
Combination Cracking Units	G. ARMISTEAD	2108
Vapour-phase Cracking	C. R. WAGNER	2112
Catalytic Reforming	D. A. HOWES	2119
Economic Significance of Cracking	G. BGLOFF	2124
SECTION 32. HYDROGENATION		2129
The Historical Development of Hydrogenation	F. BERGIUS	2130
Earlier Work on Hydrogenation at High Temperatures and Pressures	V. N. IPATIEFF	2133
The Hydrogenation of Petroleum	R. P. RUSSELL	2139
The Hydrogenation of Coal	J. G. KING	2149
The Hydrogenation-cracking of Tars	J. G. KING	2156
The Production of Water Gas from Methane and other Hydrocarbons	H. M. STANLEY	2164
SECTION 33. ENGINEERING AND CHEMICAL ENGINEERING AS APPLIED TO REFINING		2175
The Principles of Heat Transfer	H. M. WEIR	2176
The Thermal Conductivity of Solids	H. M. WEIR	2204
The Emissivity of Surfaces	E. S. L. BEALE	2206
The Calculation of the Flow of Liquids and Gases across Banks of Pipes and in Packed Columns	T. H. CHILTON	2207

CONDENSER, HEAT EXCHANGE, AND TUBE-HEATER EQUIPMENT	
Heat Exchangers and Condensers	T. H. CHILTON and T. B. DREW 2211
Heaters	L. A. MEKLER 2223
INSULATION	
Heat Transfer through Insulation	E. C. RACK 2233
Insulation of Oil Industry Equipment	E. RINEHART 2240
SECTION 34. METALS AND ALLOYS IN REFINERY EQUIPMENT 2255	
Factors to be Considered in Specifying Steel for Refinery Service	T. MCLEAN JASPER and C. W. WHEATLEY 2256
Alloyed Cast Irons in Petroleum Refining Equipment	J. S. VANICK 2258
Ferrous Metal Tubes for Refinery Service	H. D. NEWELL 2271
Choice and Design of Tubing for Furnaces and Shell and Tube Exchangers	E. S. DIXON and T. GARRARD 2288
Pressure Vessels for the Petroleum Industry	T. MCLEAN JASPER, L. J. LARSON, S. L. HOYT, and O. E. ANDRUS 2295
SECTION 35. CORROSION 2305	
The Principles of Metallic Corrosion	T. P. HOAR 2306
The Microbiological Aspect of Corrosion	A. C. THAYSEN 2316
The Corrosion of Refinery Equipment	E. THORNTON 2318
SECTION 36. INSTRUMENTS AND METERS 2321	
Hydrometers	V. STOTT 2322
Industrial Instruments	H. HARPER 2328
The Use of Instruments in Petroleum Refining	E. THORNTON 2359
SECTION 37. ELECTRIFICATION OF REFINERIES 2361	
General Electrification of Refineries	D. H. MCLACHLAN 2362
SECTION 38. POWER AND WATER SUPPLIES 2371	
Power and Water Supplies for Refineries	H. N. SWIFT 2372
SECTION 39. FIRES 2377	
Electrical Protection of Oil Storage Containers	L. C. UREN 2378
Petrol Fires in Relation to Aircraft	J. E. RAMSBOTTOM 2383

VOLUME IV**PART III****UTILIZATION OF MINERAL OILS AND THEIR DERIVATIVES**

Section 40

SECTION 40. PRODUCTS OF PETROLEUM 2389	
MOTOR SPIRITS, SOLVENTS, DIESEL FUELS, ETC.	
Introduction	F. H. GARNER 2391
Motor Fuels in the United States	J. G. DETWILER and M. P. DOSS 2395
Motor Fuels in European Countries	F. H. GARNER and E. W. HARDMAN 2407
Natural Gasoline	G. GRANGER BROWN and D. L. KATZ 2414
Aviation Fuels	R. HASKELL 2428
British Practice in Regard to Aviation Fuels	F. R. BANKS 2431
Aviation Fuels—French Practice	P. DUMANOIS 2442
Special Engine Fuels	D. A. HOWES 2444
Industrial Petroleum Solvents and White Spirits	F. N. HARRAP 2462

Petroleum as a Source of Lacquer Solvents	T. H. DURRANS	2465
Kerosine	J. KEWLEY and C. L. GILBERT	2470
Light Diesel Fuels	G. D. BOERLAGE and J. J. BROEZE	2486
Diesel Fuel	L. J. LE MESURIER	2495
Oil Gas	L. J. WILLIEN	2501
The Evaluation of Oils for Gas Making—English Practice	R. H. GRIFFITH	2523
OIL FUEL		
The Industrial Application of Fuel Oils, including Burner Practice	I. LUBBOCK, F. J. BATTERSHILL, and R. H. B. FORSTER	2525
Utilization of Fuel Oils for Steam-raising Purposes	J. S. S. BRAME	2548
Coal-in-Oil Suspensions	A. B. MANNING	2554
LUBRICANTS		
Lubrication—Introductory	D. R. PYE	2558
Chemical and Physical Forces in Lubrication	G. L. CLARK, R. R. STERRETT, and B. H. LINCOLN	2566
The Chemical Nature of Lubricating Oils	F. B. THOLE	2576
Density, Refractive Index, and Related Characteristics of Lubricating Oils, and Bituminous Substances	A. L. WARD, S. S. KURTZ, JR., and W. H. FULWEILER	2578
Lubricating Grease	F. MACKLEY	2586
Apieton Oils	C. R. BURCH	2594
The Use of Anti-oxidants in Lubricating Oils	D. A. HOWES	2595
Extreme Pressure Lubricants	H. C. MOUGEY	2598
The Practical Selection of Improved Lubricants	L. L. DAVIS, B. H. LINCOLN, and B. E. SIBLEY	2602
Mechanical Testing of Lubricants—Laboratory Engines and Work Factor Methods	G. M. MAVERICK and A. J. BLACKWOOD	2610
Engine Tests of Lubricants	C. H. BARTON and O. THORNYCROFT	2622
The Lubrication of Internal-combustion Engines	D. R. PYE	2634
Lubrication Practice	S. J. M. AULD	2642
Metal Working Oils	P. BEUERLEIN	2652
<i>Synthetic Lubricants</i>		
Synthetic Lubricating Oils	F. C. HALL	2656
The Manufacture of Synthetic Lubricating Oils	F. W. SULLIVAN, JR.	2664
Paraffin	G. H. B. DAVIS and J. C. ZIMMER	2673
WAXES		
The Commercial Grades of Paraffin and their Applications	W. J. WILSON and S. T. MINCHIN	2679
Candles and Night-lights	D. ALLAN	2696
ASPHALTIC BITUMEN, COKE, AND REFINERY RESIDUES		
The Manufacture of Asphaltic Bitumen	W. W. GOULSTON	2690
Blown Asphalt	H. B. PULLAR	2700
Asphaltic Bitumen Emulsions	F. H. GARNER	2706
Native Asphalts and Bitumens	J. S. MILLER, JR.	2710
Asphaltic Products for Pavements and Highways	P. HUBBARD	2728
Typical Asphalt Specifications for Road and Pavement Construction	J. S. MILLER, JR.	2742

CONTENTS

xv

Bituminous Paints	L. A. JORDAN	2747
The Colloidal Structure of Bitumens	F. J. NELLENSTEYN	2760
Sulphuric Acid Sludges and Sulphuric Acid Recovery	T. C. OLIVER and S. F. SPANGLER	2764
Petroleum Coke	W. F. STROUD	2772
Properties of Petroleum Coke	D. W. GOULD	2774

SYNTHETIC DERIVATIVES FROM PETROLEUM

Chlorinated Compounds and Derivatives

The Addition of Halogens to Olefine Bonds	H. B. HASS	2777
Glycols and Related Compounds from Oil Gas Olefines	B. T. BROOKS	2781
The Chlorination of Methane and its Homologues	H. B. HASS	2787
Chemicals Derived from Pentanes	C. A. THOMAS	2795

Alcohols

Catalytic Production of Ethyl Alcohol from Ethylene	R. TAYLOR	2802
Alcohols and Related Products from Petroleum Olefines	B. T. BROOKS and C. ELLIS	2805
The Synthesis of Methanol and Higher Alcohols from Water Gas	D. A. HOWES	2812
The Solubility Relationships of Mixtures of Gasolines, Benzoles, Alcohols, and Water	D. A. HOWES	2822

SPECIAL PRODUCTS

Di-isobutene and Iso-octane	S. F. BIRCH and T. TAIT	2830
White Oils	F. M. ARCHIBALD	2838
Sulpho Acids	F. M. ARCHIBALD	2840
Ichthyol	G. H. SMITH	2841
Petroleum Oils as Insecticides and Fungicides	C. POTTER	2843
Synthetic Resins from Petroleum Hydrocarbons	C. A. THOMAS	2848
Carbon-black Manufacture	C. ELLIS	2851

PART IV

DETONATION AND COMBUSTION

Sections 41 and 42

SECTION 41. COMBUSTION		2859
Combustion Phenomena of Hydrocarbons	D. M. NEWITT and D. T. A. TOWN- END	2860
Combustion Phenomena at High Pressures	D. M. NEWITT and D. T. A. TOWN- END	2884
Combustion Research in Compression-ignition Engines	G. D. BOERLAGE and J. J. BROEZE	2894
SECTION 42. DETONATION		2909
Foreword	A. C. EGERTON	2910
1 General Statement as to Existing Knowledge on Knocking and its Prevention	A. C. EGERTON	2911
2 Theory of Knock in Internal-combustion Engines	H. A. BEATTY and G. EDGAR	2927
SLOW OXIDATION		
3 Processes of Slow Oxidation Leading to Ignition	A. R. UBBELHODE	2937
4 The Susceptibility to Oxidation of Internal-combustion Engine Fuels and their Tendency to Produce Knocking in Engines	M. PRETTRE	2950

IGNITION

- 5 Ignition in Gases with Special Reference to Knock Problems D. M. NEWITT and D. T. A. TOWN-
END 2958
- 6 Spontaneous Ignition Temperatures: Determination and Significance W. HELMORE 2970
- 7 Ignition and Flame Movement G. B. MAXWELL and R. V.
WHEELER 2976

FLAME PROPAGATION AND DETONATION

- 8 Flame Propagation, Particularly with Reference to Vibratory and True Detonation Flames R. P. FRASER 2983
- 9 Flames of High-speed Detonation P. F. LAFFITTE 2995

SPECIFIC BEHAVIOUR OF FUELS AND DOPES

- 10 Knocking Characteristics and Molecular Structure of Hydrocarbons W. G. LOVELL and J. M. CAMPBELL 3004
- 11 Anti-knock Compounds G. CALINGAERT 3024
- 12 Lead Susceptibility of Gasoline F. H. GARNER 3030
- 13 Oxidants and Anti-oxidants in the Petroleum Industry E. W. J. MARDLES 3033
- 14 Researches on Detonation in France P. DUMANOIS 3054

METHODS OF KNOCK RATING

- 15 Measurement of the Knocking Characteristics of Automotive Fuels J. M. CAMPBELL and T. A. BOYD 3057
- 16 The Correlation of Road and Laboratory Knock Ratings of Motor Fuels R. STANSFIELD 3066

ENGINE ASPECTS

- 17 The Engineering Aspects of Detonation C. O. B. BEALE 3072

PART V

BITUMINOUS MATERIALS AND THEIR PRODUCTS

Sections 43 and 44

- SECTION 43. OIL SHALES, TORBANITES, CANNELS, &c. 3079
- Oil Shales, Cannel Coals, and Torbanites M. J. GAVIN 3080
- Oil Shale; Occurrence and Geology H. R. J. CONACHER 3089
- SECTION 44. SHALE OILS AND TAR OILS 3095
- Scottish Shale Oil G. H. SMITH, G. GRANT, and
S. ALLEN 3096
- Estonian Shale Oils P. N. KOGERMAN 3107
- Low-temperature Tar Oils J. G. KING 3113
- High-temperature Coal Tars W. G. ADAM 3118
- APPENDIX 3128
- INDEXES: Contributors, Names, Subjects 3131

PART II
CHEMICAL AND PHYSICAL PRINCIPLES OF
THE REFINING OF MINERAL OILS

SECTIONS 18-39

SECTION 18

NATURE OF CRUDE PETROLEUM

Mid-Continent	F. W. L. TYDEMAN and C. M. KELLOGG
California	D. R. MERRILL
Gulf Coast	A. J. KRAEMER
Canada	G. EGLOFF
Mexico	J. McCONNELL SANDERS
Venezuela	R. J. FORBES
Trinidad	I. McCALLUM
Argentina	R. J. FORBES
Colombia, Peru, and Ecuador	G. EGLOFF
Japan	M. MIZUTA
Dutch East Indies	R. J. FORBES
Burma	W. J. WILSON
Iran	F. B. THOLE
Bahrein Islands	G. EGLOFF
Iraq	M. S. MAINLAND
Egypt	R. J. FORBES
U.S.S.R.	A. VELIKOVSKY
Roumania	R. J. FORBES
Poland	J. EHRLICH and A. SZAYNA
Europe and the East	G. EGLOFF

MID-CONTINENT

By F. W. L. TYDEMAN, M.D., and C. M. KELLOGG, A.B., M.A.S.M.E.

Shell Petroleum Corporation

MID-CONTINENT crude oils are obtained from numerous oilfields distributed throughout the central part of the United States west of the Mississippi River. For present purposes, we have considered representative crude oils from the following states:

Oklahoma
 Kansas
 Texas (excluding Gulf Coast Area)
 Louisiana
 Arkansas
 New Mexico

Mid-Continent crudes often differ appreciably in age of formation. They are obtained from structural formations ranging in age from the Ordovician period of the Early Paleozoic era to the Miocene period of the Middle Cenozoic era. Since these two periods roughly represent the two extremes in the age of crude oils from the geological standpoint, it is of interest to compare the characteristics and properties of crude oils and their components having approximately the same age with each other and with crudes of other geologic periods. For this reason, we have grouped the several samples compared hereafter according to accepted geological periods of their origin.

Broadly speaking, the petroleum industry is based on the location, production, transportation, refining, and distribution of crude oil and its numerous derivatives. A brief study of the characteristics of various Mid-Continent crude oils must, therefore, involve a good many limitations of the items which are compared.

For purposes of brevity, we must confine our present discussions to a few of the principal characteristics and properties of the several crude oils and their commercial derivatives. Aside from comparative data on the crude oils themselves, we have also briefly compared gasoline, kerosene or furnace oil, gas oil, fuel oil, lubricating oil, wax or petrolatum, and asphalt fractions that are obtainable by standardized testing methods without particular reference to commercial practice.

Because there is not any standard procedure in the industry for evaluating crude oils, the standard methods used by the Shell Petroleum Corporation have been followed in the accumulation of the data presented. Accordingly, the yield data and the properties of the several fractions only approximate to commercial practice. The commercial refiner may obtain more or less gasoline and kerosine from the crude than is indicated hereafter if he changes the quality of the respective products which he manufactures. Again, it is not claimed that the crude oil analyses tabulated hereafter are accurately typical of the total production of crude from a given field, not to mention a given sand. For example, there is no evidence available to show that crude oil obtained from the Avant field in Osage County, Oklahoma, in the year 1904 had the properties which are reported for Avant crude in the following tabulation, based on a comparatively recent analysis. The analyses shown are all based on recent crude-oil samples believed to be fairly representative of current production in the indicated areas for the indicated producing horizons (sands). We have not determined what propor-

tion of the crude-oil production reported for the year 1933 has been obtained from any given producing horizon. The production data shown for 1933 are based on A.P.I. statistical bulletins.

The tabular data attached are intended to be self-explanatory. Rather than duplicate numerical references to the standard tests used in accumulation of the data, we list them hereafter.

	<i>Test method</i>
Gravity determinations (° API and Specific)	A.S.T.M. D. 287-33
Sulphur content (bomb)	A.S.T.M. D. 129-33
" " (lamp)	A.S.T.M. D. 90-30 r
Pour-point	A.S.T.M. D. 97-33
Viscosity	A.S.T.M. D. 88-33
Octane number (Motor Method)	A.S.T.M. D. 357-33 r
10% distillation	A.S.T.M. D. 86-30
Carbon residue	A.S.T.M. D. 189-30
Paraffin	Holds Method

Study of the attached data from a purely geographical standpoint allows little latitude for generalization. Thus we find crudes with high sulphur and low sulphur contents are produced in practically every part of the Mid-Continent area. In fact, crudes from different producing sands in the same comparatively small geographical area often differ appreciably in sulphur content. For example, in the Big Lake field of Reagan County, Texas, crude from the Cambro-Ordovician 'Ellenburger' sand has a sulphur content of 0.16%, while crudes from the neighbouring West Texas oilfields produced from the Permian period 'Big Lime' have sulphur contents ranging from 0.85% for Chalk to 1.99% for Upton.

The lowest gravity crude (20.8° API.) in the table is Urania crude from Eocene period 'Wilcox' sand, La Salle Parish, Louisiana, while the highest gravity crude (44.5° API.) in the table is Pampa crude from the Pennsylvanian-Permian period, 'Panhandle Lime', Gray County, Texas. Higher gravity crudes than 45° API. are produced in the Mid-Continent occasionally. However, most of the Mid-Continent crudes lie within this range of gravity, i.e. 20° API. to 43° API.

From the standpoint of pipeline transportation, the pour points of crude oil are important. Most Mid-Continent crudes have low pour-points, primarily due to their comparatively high gasoline and kerosine contents. Exceptions are the Panhandle crudes from the Pennsylvanian-Permian period 'Panhandle Lime', and the East Texas crudes from the Cretaceous period 'Woodbine' sand. It will be noted that in the case of the East Texas Longview crude, the high pour-point is at least partially attributable to its high wax content.

The viscosities of crude oils are also important from the pipeline transportation standpoint. In general, the viscosities of Mid-Continent crudes are comparatively low under the climatic conditions prevailing in the Mid-Continent Area, and accordingly these crudes are transported by pipeline quite readily. Possible exceptions are Smackover heavy, Caddo heavy, Urania, Yates Tobarg crudes. However, since the large proportion of the crudes produced in the Mid-Continent have comparatively low viscosities, the normal pipeline blends of such crudes,

although including small quantities of more viscous crudes in the mixture, are sufficiently low in viscosity to permit ready pipeline transportation.

Once a crude oil has been produced and transported to a refinery, the manufacture of commercial products therefrom is the next operation. The first step in the refining process is fractionation or, for example, separation of the crude into the following fractions:

- a. Gasoline
- b. Kerosine and/or furnace oil
- c. Gas oil
- d. Residual fuel oil

The above process (normally called topping) is a general practice throughout the industry. When it is desired to manufacture lubricating oils and/or asphalts, the above distilling process may be carried farther when the residual fuel oil (d) is fractionated, normally at less than atmospheric pressure, into the following cuts:

- d-1 Heavy gas oil
- d-2 Wax or lubricating oil distillate(s)
- d-3 Heavy lubricating oil bottoms fraction or asphalt flux bottoms fraction

As the greatest general interest probably applies to the manufacture of gasoline, kerosine, gas oil, and residual fuel oil, we have shown in the following tabulations certain potential yields of these products with certain corresponding properties. It will be noted that the final boiling-points of the various gasoline fractions compared hereafter are approximately 400° F. in all cases, the other boiling-points being allowed to vary as the composition of the crude may establish. The 'maximum potential kerosine' cuts have boiling ranges from 340° F. I.B.P. to 480° F. F.B.P. approximately. In case a crude oil does not yield satisfactory kerosine, or for some other practical reason, the 'maximum potential furnace-oil' yield has been determined instead of the kerosine yield. The furnace-oil fraction has a boiling range from about 370° F. I.B.P. to about 525° F. F.B.P., although the F.B.P. varies through rather wide limits, as there is a viscosity control specification of 500 seconds Saybolt Thermo Viscosity at 60° F. as well as a volatility specification for this product. The gas-oil yield includes all distillates not included in the gasoline, kerosine, or furnace-oil fractions that must be distilled from the crude in order to obtain a residual fuel-oil fraction having the same flash-point as the residuum normally obtained in analogous plant scale operations.

Description of Fractional Distillation Analyses.

For better understanding of the fractionating procedure followed, we briefly describe a typical analysis of a West Texas crude of Permian origin as performed by the Shell Petroleum Corporation.

A sample of crude oil from Howard County, Texas, was fractionated in a laboratory batch still column of high efficiency into fifteen distillate fractions, constituting 50.6% by volume of the crude charge, leaving 49.3% by volume residue bottoms, thus indicating a distilling loss of 0.1% by volume.

From cuts 1 to 5 inclusive, which amounted to 24.1 vol. % of the crude, a naphtha blend was prepared having the following composition:

Cuts	By volume
No. 2	5%
No. 3	10%
Nos. 4 and 5	85%
Total	100%

The composition of this naphtha blend is based on analysis of naphtha cuts from commercial furnace oil. The rest of cuts 1 to 5 inclusive, not used in the naphtha blend, was composited as base straight-run gasoline.

Cuts 6 to 11 inclusive, which amounted to 13.74% of the crude by volume, were composited as a base furnace-oil fraction. To this was added sufficient naphtha blend to attain furnace-oil volatility requirements. The quantity of naphtha used for this purpose amounted to 2% by volume of the crude. In this manner was determined the maximum potential yield of furnace oil, obtainable from this crude which met the standard furnace-oil specifications. The remainder of the naphtha was then returned to the base straight-run gasoline. The maximum 400° F. E.P. straight-run gasoline yield obtainable when manufacturing maximum furnace oil was accordingly 22.1% by volume of the crude.

Cuts 12 to 15 inclusive, which amounted to 12.76% of the crude by volume, were composited to produce the gas-oil fraction.

Properties of these various fractions were then determined according to standard tests.

The final yields are summarized as follows:

	%
Gasoline 400° F. E.P.	22.1
Furnace oil (maximum)	15.7
Gas oil	12.8
Fuel oil (residual)	49.3
Loss	0.1
Total	100.0

Cuts up to 405° F. temperature of the vapour were made at atmospheric pressure. All cuts obtained above 405° F. vapour temperature were distilled at an absolute pressure of 4 mm. of mercury at the top of the column. The maximum temperature of the bottoms fraction in the distilling flask was 530° F. attained when distilling off cut No. 15. Accordingly, cracking of the heavy fractions of the crude was carefully avoided during the entire distillation procedure.

The results obtained are accurately reproducible and give the maximum theoretical yields of the most valuable products that are obtainable by fractional distillation.

The fractionating efficiency of the column used may be judged by the fact that a mixture consisting of equal parts of benzene, toluene, and xylene when fractionated on this column gave the following distillation curve when operating at atmospheric pressure:

Cut	% distillate	Vapour temperature ° F.
1	0-31	175
2	31-37	175-226
3	37-66	226-230
4	66-70	230-274
5	70-84	274-275

Distillation was stopped at the 84% recovered point.

Economic Importance.

The following tabulation, which is taken from Form No. 3 A.P.I. Statistical Bulletin of 22 May 1934, briefly indicates the economic importance of crude-oil production in the Mid-Continent area during the period 1918-34:

NATURE OF CRUDE PETROLEUM

Year	Production, barrels		Wells completed	
	Total	Daily average	Total	Producing oil-wells
1918	179,383,000	491,500	14,800	10,283
1919	193,147,000	529,200	15,926	11,307
1920	250,111,000	683,400	19,982	14,031
1921	258,461,000	708,100	11,088	7,212
1922	310,992,000	852,000	12,742	8,836
1923	348,460,000	954,700	13,046	8,410
1924	375,479,000	1,025,900	11,452	7,279
1925	424,331,000	1,162,500	14,288	8,906
1926	423,867,000	1,161,300	17,600	10,912
1927	546,987,000	1,498,600	13,437	7,318
1928	553,027,000	1,511,000	12,248	6,129
1929	583,058,000	1,597,400	12,689	6,368
1930	531,447,000	1,456,000	11,098	5,487
1931	543,736,000	1,489,700	7,682	4,937
1932	493,034,000	1,347,100	10,520	7,959
1933	594,438,000	1,628,600	7,223	4,880

In 1933 the production of crude oil in the Mid-Continent area amounted to about two-thirds of the total crude-oil production in the United States.

The preceding data and Table I do not indicate the potential yields and properties of viscous industrial oils, lubricants, and asphalt products obtainable from the various kinds of Mid-Continent crude oils.

Lubricating Oils.

Any discussion of Mid-Continent crude oils would be incomplete if no reference was made to these potentialities. It should be stressed, however, before any further discussion, that the market demand for such products has not yet attained sufficient magnitude to provide an outlet for all the potential industrial oils, lubricants, and asphalts which are obtainable from Mid-Continent crudes. Accordingly, it is the general practice of Mid-Continent refiners to select the best crude-oil residue available for the purpose of manufacturing these commodities.

For example, the production of lubricants according to Form No. 11 A.P.I. Statistical Bulletin, 22 May 1934, during the year 1933 in the United States amounted to 23,805,000 barrels. Again, referring to *U.S. Bureau of Mines Minerals Yearbook*, 1932-3, part 3, p. 557, the production of asphalt at petroleum refineries in the United States from crude petroleum produced in the United States is reported to have been 1,115,547 tons, or approximately 6,150,000 barrels, assuming that 5.5 barrels of asphalt equal 1 ton of asphalt (2,000 lb.). Accordingly, the total volume of lubricants and asphalts manufactured from crude oils produced in the United States amounts to only about 3.3% of the volume of crude oil produced in the United States. Since comparatively large portions of the lubricants and asphalts manufactured in the United States were obtained from Eastern, Gulf Coast, Rocky Mountain, and California crudes, it follows that it is not necessary to obtain high yields of lubricants and asphalt products to supply existing markets. However, the processes and raw materials that give the best yields and qualities of such products are naturally preferred in manufacturing operations.

It is, then, apparent that a discussion of a comparatively

limited number of crude oils will suffice when considering the yields and properties of lubricants and asphalts obtainable from Mid-Continent crudes. In these discussions, it should be understood that some of the data are based on laboratory experiments and some on actual plant scale operations. Accordingly, it is to be expected that actual refining operations will vary somewhat from the figures given, depending on methods of operation and properties of finished products obtained.

Lubricants may be broadly grouped into two classes, namely, neutrals and bright stocks. Neutrals make up the less viscous lubricants ranging in viscosity from, say, 55 seconds Saybolt Universal at 100° F. to 1,500 seconds Saybolt Universal at 100° F. These are often termed pale or red oils, as distinguished by the colour of the oil through transmitted light.

Bright stocks range in viscosity roughly from 125 seconds Saybolt Universal at 210° F. to 200 seconds Saybolt Universal at 210° F.

All petroleum lubricants are manufactured from crude-oil topping-plant residue fractions. Depending on the composition of these fractions, the properties of lubricants obtained will vary.

Of the various Mid-Continent crude-oil residues available, those of the Cambro-Ordovician, Ordovician, Mississippian, and Pennsylvanian periods are most suitable for manufacture of paraffinic bright stocks and neutrals. Low pour-point residues of the Permian, Cretaceous, and more recent geologic periods are most suitable for manufacture of naphthenic neutrals. Few, if any, bright stocks are manufactured from residues derived from crudes of the Permian and more recent periods.

Table II indicates the yields and properties of lubricants obtainable from selected Mid-Continent crudes.

Asphalts.

Although the manufacture of asphalt products from Mid-Continent crudes is a comparatively recent development, it is probable that it will increase in importance in the future. Asphalt products are primarily used for paving, roofing, waterproofing, and briquetting purposes, although numerous other uses are made of them. Mid-Continent asphalts are suitable for all of these purposes. Manufacture of commercial asphalts from Mid-Continent crudes generally involves the following operations:

- A. The topping-plant residue is distilled at atmospheric or reduced pressure to yield a bottom product commonly termed 'asphalt flux' having a softening point (A.S.T.M. D. 36-26) of approximately 100° F.
- B. The asphalt flux thus obtained is blown with air while hot to produce asphalts having the desired penetrations.

Table III shows the potential yields and properties of asphalts obtainable from selected Mid-Continent crudes.

Acknowledgement.

The authors are indebted to the Management of the Shell Petroleum Corporation for the use of the Company's data and for permission to publish this article.

TABLE 1c
Characteristics of Mid-Continent Petroleum

GEOLOGICAL AGE	PENNSYLVANIAN										KANSAS
	TEXAS (NORTH)		TEXAS (WEST CENTRAL)		OKLAHOMA		KAY		SOUTH BRAMAN	CHEROKEE	
STATE	WICHITA	WILMBARGER	SHACKLEFORD	COOK	AVANT	OSAGE & KAY	NOBLE & KAY	TONKAWA			1924
POOL	SOUTH ELECTRA	ROCK CROSSING	COOK	1914	1904	BURBANK	1922	1922	1924	1916	CHEROKEE
DATE OF DISCOVERY	1911	1924	1914	1914	1904	1920	1922	1922	1924	1916	CHEROKEE
PRODUCTION 1933 BARRELS (c)	2,913,000 (g)	2,904,000 (g)	1,128,000 (g)	1,128,000 (g)	6,310,000 (g)	3,584,000	802,000	802,000	298,000 (c)	4,154,000 (g)	CHEROKEE
Producing Sand	Sweetite	Sweetite	Cook	Sweetite	Bartlettville	Burbank	Hover	Hover	Layton	Sulphur	CHEROKEE
Gravity, °API, at 60° F.	30.9	20.6	33.7	40.8	17.6	25.1	38.7	38.0	29.4	32.2	CHEROKEE
Specific Gravity, % by Wt. (Bomb)	0.8294	0.8236	0.8236	0.8236	0.602	0.833	0.837	0.837	0.808	0.808	CHEROKEE
Viscosity at 60° C. (104° F.)	113	6.6	0.33	0.33	0.23	0.24	0.20	0.19	0.36	0.36	CHEROKEE
Viscosity at 40° C. (104° F.)	37	48.0	42	42	45	42	34	34	40	40	CHEROKEE
YIELD WHEN MAKING MAXIMUM KEROSENE OR FURNACE OIL PER CENT. BY VOLUME											CHEROKEE
Gasoline (Maximum)	30.9	20.6	33.7	40.8	17.6	25.1	38.7	38.0	29.4	32.2	CHEROKEE
Furnace Oil (Maximum)	44.5	42.0	47.5	47.5	16.7	16.7	16.9	16.9	18.1	16.0	CHEROKEE
Gas Oil	8.9	6.2	6.7	6.7	14.5	10.1	13.0	11.3	9.7	10.2	CHEROKEE
Loss	37	50.3	44.2	44.2	5.1	47.7	31.2	31.2	42.3	41.4	CHEROKEE
Total	100.0	100.0	100.0	100.0	100.0	100.0	100.0	100.0	100.0	100.0	CHEROKEE
KEROSENE											CHEROKEE
Gravity, °API, at 60° F.	59.7	57.2	60.7	60.7	51.6	57.7	58.4	58.8	57.0	59.2	CHEROKEE
Sulphur Content, % by Wt. (Lamp)	0.077	0.012	0.017	0.017	0.008	0.009	0.005	0.006	0.018	0.013	CHEROKEE
A.S.T.M. Number (Motor Method)	45.0	42.0	47.5	47.5	37.5	44.5	46.5	47.0	45.0	45.5	CHEROKEE
% Recovered at 60° F.	167	206	170	170	218	188	176	176	190	181	CHEROKEE
" " 90° F.	260	272	273	273	302	284	273	272	267	273	CHEROKEE
" " 100° F.	400	405	403	403	402	404	398	393	400	398	CHEROKEE
% Aromatics by Wt. (m)	4.8	4.6	7.3	7.3	11.1	CHEROKEE
Aniline Point, °F. (m)	13.7	14.6	14.2	14.2	CHEROKEE
KEROSENE OR FURNACE OIL											CHEROKEE
Gravity, °API, at 60° F.	44.2	44.6	44.6	44.6	41.1	43.9	42.7	43.1	43.4	43.8	CHEROKEE
Sulphur Content, % by Wt. (Lamp)	0.043	0.06	0.035	0.035	0.009	0.019	0.007	0.007	0.000	0.018	CHEROKEE
A.S.T.M. Number (Motor Method)	37.5	36.5	36.5	36.5	33.8	38.3	38.6	38.4	38.2	38.5	CHEROKEE
% Recovered at 60° F.	457	442	442	442	416	416	416	417	416	415	CHEROKEE
" " 90° F.	457	444	444	444	456	446	446	447	446	445	CHEROKEE
" " 100° F.	499	492	492	492	474	480	476	473	485	476	CHEROKEE
End Point, °F.	CHEROKEE
GRA OIL											CHEROKEE
Gravity, °API, at 60° F.	37.4	37.4	38.9	38.9	35.6	37.6	36.1	36.7	36.5	37.2	CHEROKEE
Viscosity, Sec. Say. Univ. (100° F.)	38.0	38.0	38.0	38.0	38.0	37.0	38.0	38.0	39.0	38.0	CHEROKEE
Sulphur, % by Wt. (Bomb)	0.12	0.12	0.11	0.11	0.17	0.17	0.13	0.18	0.21	0.15	CHEROKEE
Four-point, °F.	B.-25	B.-25	B.-25	B.-25	-3	0	10	10	0	0	CHEROKEE
RENDU (FROM FINE-DROPPING OPERATIONS)											CHEROKEE
Gravity, °API, at 60° F.	24.1	24.1	24.5	24.5	24.7	26.1	25.8	26.1	24.0	24.8	CHEROKEE
Sulphur, % by Wt. (Bomb)	0.58	0.66	0.60	0.60	0.70	0.30	0.41	0.30	0.59	0.47	CHEROKEE
Four-point, °F.	89	89	75	75	50	65	80	80	69	55	CHEROKEE
Colour, °API, at 60° F.	4	4	4	4	4	4	4	4	4	4	CHEROKEE
Colour, °API, at 100° F.	Black	Black	Black	Black	Black	Black	Black	Black	Black	Black	CHEROKEE
Paraffin, % by Wt.	2.5	1.3	2.0	2.0	6.3	CHEROKEE

NATURE OF CRUDE PETROLEUM

TABLE 1d
 Characteristics of Mid-Continent Petroleum

GEOLOGICAL AGE	PENNSYLVANIAN OR PERMIAN				FRESHMAN				TEXAS (WEST)				NEW MEXICO				TEXAS (WEST)					
	STATE	COUNTY	POOL	DATE OF DISCOVERY	GRAY	WEST PANFA	BOKER	COCKRELL	HUTCHINSON	GLASSCOCK	CHALK	UTYTON	UTYTON	WINNLER	HENDRICKS	YATES DEEP	PIEDS	LEA	HOBBS	TEXAS (WEST)	TEXAS (WEST)	
					10,369,000 (g)	1927		1926	3,977,000 (g)	5,665,000 (l)	1925	6,031,000 (l)	6,031,000 (l)	8,180,000	1926	20,187,000 (c)	11,184,000			20,187,000 (c)	1926	
					Producing Sand				Granite Wash													
					Gravity (Dry Basis) °API, at 60° F.	40	39.40	36	36	37.5	37.3	27.8	27.8	28.1	29.5	29.5	28.6	32.6			21.0	
					Sulphur Content, % by Wt. (Bomb)	0.42	0.30	0.48	0.55	0.85	0.85	0.83	0.83	0.866	0.789	0.789	0.8623			0.9279		
					Four-point, °F.	43.30	43.30	43.30	43.30	43.30	43.30	43.30	43.30	43.30	43.30	43.30	43.30	43.30			43.30	
					Viscosity at 40° C. (104° F.)	38	38	38	38	38	38	38	38	38	38	38	38	38			38	
					Viscosity at 40° C. (104° F.)	48	48	48	48	48	48	48	48	48	48	48	48	48			48	
					Yields when Making Maximum Kerosene or Furnace Oil, by Volume																	
					Gasoline	44.7	44.7	44.7	44.7	44.7	44.7	44.7	44.7	44.7	44.7	44.7	44.7	44.7			44.7	
					Kerosene (Maximum)	11.6	11.6	11.6	11.6	11.6	11.6	11.6	11.6	11.6	11.6	11.6	11.6	11.6			11.6	
					Gas Oil (Minimum)	4.5	4.5	4.5	4.5	4.5	4.5	4.5	4.5	4.5	4.5	4.5	4.5	4.5			4.5	
					Fast Oil	39.4	39.4	39.4	39.4	39.4	39.4	39.4	39.4	39.4	39.4	39.4	39.4	39.4			39.4	
					Total	100.0	100.0	100.0	100.0	100.0	100.0	100.0	100.0	100.0	100.0	100.0	100.0	100.0			100.0	
					GLASSBORO																	
					Gravity °API, at 60° F.	61.9	61.9	61.9	61.9	61.9	61.9	61.9	61.9	61.9	61.9	61.9	61.9	61.9			61.9	
					Sulphur Content, % by Wt. (Lamp)	0.053	0.053	0.053	0.053	0.053	0.053	0.053	0.053	0.053	0.053	0.053	0.053	0.053			0.053	
					Octane Number (Motor Method)	58.5	58.5	58.5	58.5	58.5	58.5	58.5	58.5	58.5	58.5	58.5	58.5	58.5			58.5	
					A.S.T.M. 10° Rec. at 10° F.	161	161	161	161	161	161	161	161	161	161	161	161	161			161	
					10° Rec. at 10° F.	152	152	152	152	152	152	152	152	152	152	152	152	152			152	
					20° Rec. at 20° F.	233	233	233	233	233	233	233	233	233	233	233	233	233			233	
					20° Rec. at 20° F.	250	250	250	250	250	250	250	250	250	250	250	250	250			250	
					20° Rec. at 20° F.	260	260	260	260	260	260	260	260	260	260	260	260	260			260	
					% Aromatics by Wt. (m)	46.0	46.0	46.0	46.0	46.0	46.0	46.0	46.0	46.0	46.0	46.0	46.0	46.0			46.0	
					% Aromatics by Wt. (n)	
					Aniline Point, °F. (m)	
					Aniline Point, °F. (n)	
					KEROSENE OR FURNACE OIL																	
					Gravity °API, at 60° F.	41.2	41.2	41.2	41.2	41.2	41.2	41.2	41.2	41.2	41.2	41.2	41.2	41.2			41.2	
					Sulphur Content, % by Wt. (Lamp)	0.24	0.24	0.24	0.24	0.24	0.24	0.24	0.24	0.24	0.24	0.24	0.24	0.24			0.24	
					A.S.T.M. 10° Rec. at 10° F.	425*	425*	425*	425*	425*	425*	425*	425*	425*	425*	425*	425*	425*			425*	
					10° Rec. at 10° F.	468	468	468	468	468	468	468	468	468	468	468	468	468			468	
					20° Rec. at 20° F.	507	507	507	507	507	507	507	507	507	507	507	507	507			507	
					20° Rec. at 20° F.	514	514	514	514	514	514	514	514	514	514	514	514	514			514	
					End Point, °F.	
					GLD OIL																	
					Gravity °API, at 60° F.	39.0	39.0	39.0	39.0	39.0	39.0	39.0	39.0	39.0	39.0	39.0	39.0	39.0			39.0	
					Viscosity, Sec. Sayb. Univ. 100° F.	
					Sulphur, % by Wt. (Bomb)	0.27	0.27	0.27	0.27	0.27	0.27	0.27	0.27	0.27	0.27	0.27	0.27	0.27			0.27	
					Four-point, °F.	25	25	25	25	25	25	25	25	25	25	25	25	25			25	
					KEROSENE (FROM FINECING OPERATIONS)																	
					Gravity °API, at 60° F.	28.8	28.8	28.8	28.8	28.8	28.8	28.8	28.8	28.8	28.8	28.8	28.8	28.8			28.8	
					Sulphur, % by Wt. (Bomb)	0.81	0.81	0.81	0.81	0.81	0.81	0.81	0.81	0.81	0.81	0.81	0.81	0.81			0.81	
					Four-point, °F.	90	90	90	90	90	90	90	90	90	90	90	90	90			90	
					Carbon Residue, % by Wt. (Combustion)	D.L.	D.L.	D.L.	D.L.	D.L.	D.L.	D.L.	D.L.	D.L.	D.L.	D.L.	D.L.	D.L.			D.L.	
					Paraffin, % by Wt.	

TABLE II
 Characteristics and Yields of Lubricants obtained from Selected Mid-Continent Crudes

CRUDE OIL	TONGAWA-MARSHALL		MID-CONTINENT (CENTRAL AND NORTHERN OKLA.)		RANGER	BIG LAKE		HENRICKS-YATES	
	KAY-LOGAN	OKLAHOMA	OKLAHOMA	OKLAHOMA		EASTLAND	REAGAN	TEXAS	WINNELL-POOR
COUNTY	OKLAHOMA		OKLAHOMA		TEXAS	TEXAS		TEXAS	
STATE	OKLAHOMA		OKLAHOMA		TEXAS	TEXAS		TEXAS	
PROCESS	(A)	(B)	(A)	(B)	(B)	(B)	(B)	(C)	(C)
YIELDS PER CENT. BY VOLUME									
Finished Neutral 65 to 300 Vls. at 100° F.	78.4	69.0	71.8	69.0	68.3	68.3	54.0		
Finished Neutral 300 to 1,500 Vls. at 100° F.	4.9	..	2.8	13.5		
Finished Bright Stocks	1.3	..	7.9	11.0		
Wax Laminate (Underwood and Unfinished Neutrals)	3.8	7.6	..	8.6	..	10.3	..		
Paraffin (Underwood and Unfinished Neutrals)	16.4	16.4	6.0	16.0	..	16.0	..		
Solvent Extracts (Viscosity Index below 0)	3.7	1.7	..		
Light Flux (85° F. S.E.)	4.5	..	6.5		
Highly Viscous Residue	..	1.0	..	0.5	17.0		
Acid Sludge	..	3.2	..	2.4	..	1.6	..		
Loss	..	1.4	..	1.2	..	2.6	1.5		
TOTAL	100.0	100.0	100.0	100.0	100.0	100.0	100.0	100.0	100.0
PROPERTIES OF LUBRICANTS									
Neutrals 65 to 300 Vls. at 100° F.	100	..	100	90		
Neutrals 300 to 1,500 Vls. at 100° F.		
Carbon Residue per cent. by Weight	0.03	..	0.05		
Neutrals 500 to 1,500 Vls. at 100° F.	100	..	100	58		
Four-pour, ° F.	0	..	0	10		
Carbon Residue per cent. by Weight	0.3	..	0.3	0.7		
Bright Stocks	98	73	98	79		
Four-pour, ° F.	0	23	0	20		
Carbon Residue per cent. by Weight	0.4	1.0	0.4	2.0		
Viscosity Second S.U. at 210° F.	230	150	150	150	150	150	..		
DETAILS OF PROCESS									
Neutrals 65 to 300 Vls. at 100° F.	Distillation Base Solvent Extraction Dewaxing (c) Fractionation Contact Filtration	Distillation Base Solvent Extraction Dewaxing (c) Fractionation Contact Filtration	Distillation Base Solvent Extraction Dewaxing (c) Fractionation Contact Filtration	Distillation Base Solvent Extraction Dewaxing (c) Fractionation Contact Filtration	Distillation Base Solvent Extraction Dewaxing (c) Fractionation Contact Filtration	Distillation Base Solvent Extraction Dewaxing (c) Fractionation Contact Filtration	Distillation Base Solvent Extraction Dewaxing (c) Fractionation Contact Filtration	Distillation Base Solvent Extraction Dewaxing (c) Fractionation Contact Filtration	Distillation Base Solvent Extraction Dewaxing (c) Fractionation Contact Filtration

a Refer to Oil and Gas Journal, 31 March 1933, p. 92. b In Naphtha solution. c In Propane solution.

TABLE III
 Characteristics and Yields of Asphalts from Selected Mid-Continent Crudes

CRUDE OIL	HEALDTON		ELYRIA		HENDRICKS	
	CARTER		MCPHERSON		WINKLER	
STATE	OKLAHOMA		KANSAS		TEXAS	
GRAVITY OF CRUDE ° API	31.7		37.1		28.0	
YIELDS WHEN MAKING ASPHALT FLUX FROM CRUDE Asphalt Flux % by Volume of Crude	16.4		16.7		11.5	
	Flux	Oxidized	Flux	Oxidized	Flux	Oxidized
ASPHALT						
Specific Gravity at 60° F.	0.977	..	0.992	..	1.02	1.02
Softening Point, ° F.	80	149	87	150	107	125
Penetration at 77° F. (100 g. 5 sec.)	50	310+	50	148	52
Float Test at 150° F. Seconds	60	..	89
Per cent. Fixed Carbon	6.4	..	12.9	..	11.7	13.5
" Insoluble in 86° Naphtha	4.0	20.3	11.7	23.7	11.1	17.1
" Soluble in Carbon Tetrachloride	99.64	..	99.5	..	99.7	99.6
" Paraffin Scale	1.0	..	0.9
" Sulphur	1.57	..	1.62	..	2.66	..
Penetration at 32° F. (200 g. 60 sec.)	238	18	60	26	32	18
" 77° F. (50 g. 1 sec.)	300+	..	155
" 115° F. (50 g. 5 sec.)	112	..	106	..	232
" 77° F. → Penetration at 32° F.	2.8	..	1.9	..	2.9
" 115° F. ÷ " 77° F.	2.2	..	2.1	..	4.5
Ductility at 77° C. cm.	12	..	8	..	110+

Tests in conformity with A.S.T.M. tests or those outlined in Bulletin 1216 U.S. Department of Agriculture.
 Paraffin scale determined by method described in 'Examination of Hydrocarbon Oils and Saponifiable Fats', by Holde and Mueller.

NOTES TO TABLE I

- y. The Arbuckle is of Cambro-Ordovician age.
 x. Production shown includes crude oil from all producing sands.
 a. " for first six months of year only.
 b. " " last " " "
 c. " " Osage Area excluding Burbank.
 d. " " Crane and Upton Counties jointly.
 e. The figures given do not include any estimate of any oil which might have been surreptitiously produced.
 f. Production data not available.
 g. " given is for entire county.
 h. " includes Kilgore and Joiner Areas.
 i. " for Howard and Glasscock Counties jointly.
 m. Method used to determine aniline point of gasoline and per cent. aromatics.

Definition. The aniline point of a hydrocarbon mixture is the temperature above which equal volumes of the hydrocarbon and pure, dry, recently distilled aniline are miscible with each other. The aniline used should be protected from the light and kept in contact with solid caustic soda.

The aniline point is measured by pipetting 10 c.c. each of the gasoline and aniline into a jacketed 1-in. diameter test-tube, fitted with a stirrer and thermometer dipping into the liquid. The thermometer must be so fixed that the bulb is placed centrally in the liquid. The mixture is warmed till the liquids give a clear solution, and is then allowed to cool with stirring till the mixture becomes turbid. It is then re-warmed until it just clears again and then allowed to cool. The temperature at which the thermometer bulb is just completely obscured, owing to the turbidity of the liquid, is taken as the aniline point. The second heating is necessary in accurate work to

avoid the error, due to lag of the thermometer, in cooling rapidly from temperatures well above the aniline point.

a. **Total Aromatics.** 30-40 c.c. of the sample to be examined are sulphonated by agitation with three times their volume of 98% sulphuric acid for half an hour. The product is separated from the acid and washed with soda and water.

The difference between the aniline points of the sample before and after sulphonation gives the percentage of aromatics in accordance with a chart based on the following table:

Change of aniline point on sulphonation	% Aromatics by weight
5° C.	5.9
10° C.	11.5
15° C.	16.8
20° C.	21.9

The washing after sulphonation may be eliminated and replaced by treatment with a mixture of equal parts of calcium oxide and calcium chloride for two or three minutes with frequent agitation, or, alternatively, any treatment after sulphonation may be neglected, since it has been found that the error introduced by this omission is negligible.

When a gasoline contains more than 20% of aromatic hydrocarbons, it must be diluted with an equal volume of the same spirit from which the aromatic hydrocarbons have been removed by sulphonation before carrying out this test.

* 10% recovered at temperature stated.

** Sample insufficient for test.

CALIFORNIA

By DAVID R. MERRILL, Ph.D., A.I.Ch.E.

Manager of Research, Union Oil Company of California

The oilfields of California are usually grouped geographically into three divisions: the San Joaquin Valley Division, including Fresno, King, and Kern Counties; the Coastal Division, including Santa Barbara, San Luis Obispo, and Ventura Counties; and the Los Angeles Basin, including Los Angeles and Orange Counties. Prior to 1894 practically all of the production in the State was from the Ventura-Newhall District in the Coastal Division. Production in the Los Angeles Basin began with the discovery of the Los Angeles field in 1892, and by 1895 65% of the crude-oil production of California was accounted for by this division. Production in the San Joaquin Valley Division began with the discovery of the Sunset field in 1894. This was followed by the discovery of the Coalinga field in 1896, McKittrick in 1898, Kern River in 1899, and Midway in 1901. These fields were so productive that from 1901 to 1921 the San Joaquin Valley Division furnished the greater part of California production and established the San Joaquin Valley heavy crude oil as the typical California petroleum of that period. Although large quantities of lighter oil have since been found in all three of the producing divisions, the San Joaquin Valley heavy crude oil is still of sufficient importance to warrant a rather detailed description of its characteristics.

This crude oil may be described as a highly asphaltic petroleum of relatively low gasoline content. The wax content is usually very low, and crude oils can readily be selected which are so free from wax that lubricating oils with pour-points below 0° F., except for the heaviest grades, can be produced from them without any dewaxing operation. Accompanying the negligible wax content is a relatively low degree of paraffinic characteristics in all fractions. For example, the 425° F. F.B.P. straight-run gasoline, as distilled from the crude oil and without blending with natural gasoline, has a typical octane number by the A.S.T.M.-C.F.R. Motor Method of about 68 and the lubricating distillate a typical viscosity-gravity constant of 0.91. A naphtha fraction boiling between 200 and 300° F. has been estimated, from aniline-point determinations before and after acid treatment, to contain about 5% by weight of aromatic hydrocarbons, about 75% naphthenes or alicyclic hydrocarbons, and not more than 20% of paraffinic or open chain aliphatic hydrocarbons. For fractions of higher boiling-point and greater molecular complexity, it is more difficult to differentiate between the different hydrocarbon types, but it is concluded from the examination of extracts from selective solvent extractions that the content of hydrocarbons exhibiting some aromatic character, as indicated by high specific gravity and viscosity-gravity constant, increases in the lubricating oil fractions to about 40% or more.

Very large quantities of California or western-type oils have been produced from such lubricating distillates. The western oils marketed on the Pacific Coast have been both those produced by simple acid treatment and having a typical viscosity-gravity constant of about 0.89 and viscosity indices ranging from about 15 for the lightest motor-oil grades to -40 for the heaviest, and oils produced by the Edleanu process of extraction with liquid sulphur dioxide, with or without supplementary acid treatment, and having

viscosity-gravity constants of 0.85 to 0.87 and viscosity indices from about 50 to -10.

The typical San Joaquin Valley crude oils for the most part fall in the range of 12 to 28° API. A large proportion of the production is in the heavy or so-called unrefinable class, heavier than 20° API. These heavy crude oils are often of sufficiently high flash-point to permit their use directly as boiler fuel or as road oil or liquid asphalt. In other cases the removal of a few per cent. of light distillate is required to produce a marketable grade of fuel oil having, for example, a viscosity of 125 sec. Saybolt Furol at 122° F. The lighter grades of these crude oils have gasoline contents ranging up to about 20%. After removal of the gasoline, the residue may be used as fuel oil, upon further distillation to remove gas oil and lubricating distillate fractions, may be reduced to a steam-blown asphalt suitable for paving purposes. In the non-cracking distillation a yield of about 35% of 40 penetration asphalt (77° F., 100 g., 5 sec.) is typical for a 15° API. crude oil. The corresponding yields of other fractions are about 5% gasoline, 27% gas oil, and 33% viscous lubricating distillates. An additional 5% or more of lubricating distillate can be recovered by carrying the distillation to asphalt of zero penetration. By cracking operations of the viscosity reduction type, a higher yield of gas oil than by simple distillation may be obtained while still producing a residue of suitable viscosity for use as fuel oil. The gasoline obtained by the cracking of gas oil from this type of crude oil is similar to the straight-run gasoline in having an unusually high octane number.

The San Joaquin Valley heavy crude oils have sulphur contents in the intermediate range for California oils. Typical values for the different fractions are: straight-run gasoline 0.06% sulphur, gas oil 0.5%, medium lubricating distillate 0.9%, fuel oil 0.9%, and paving-grade asphalt 1.0%.

The fractions from the typical San Joaquin Valley heavy crude oils have relatively high contents of naphthenic acids and nitrogen bases in comparison with the lighter and more paraffinic crude oils of California.

In the period from 1901 to about 1921, the heavy oil from the San Joaquin Valley fields was the predominant type of California crude oil, but by 1923 the production from newly discovered light oilfields was large enough to overshadow the heavy-oil output of the San Joaquin Valley and bring about a substantial increase in the average API. gravity of California production. The first of these important light oilfields was the Ventura Avenue field in the Coastal Division, discovered in 1916. This was followed by a series of important light-oil discoveries in the Los Angeles Basin; namely, Santa Fe Springs and Richfield in 1919, Huntington Beach in 1920, Long Beach or Signal Hill in 1921, Dominguez in 1923, and Inglewood in 1924. Later important developments were the discoveries of the Elwood field in the Coastal Division in 1927, and particularly the Kettleman Hills field in the San Joaquin Valley in 1928.

Initial production at Kettleman Hills was of a very light crude oil of about 60° API. with a very high gasoline content and accompanied by a large production of natural gas, but by going lower into the formation the excessive gas-oil ratios were corrected, and a crude oil of about 38° API.

was produced. It is necessary to distinguish carefully between the heavy oils from the earlier and relatively shallow San Joaquin Valley fields and the lighter oils from Kettleman Hills and other more recent deep developments, such as North Belridge Deep Zone discovered in 1930. Because of the large actual and potential production at Kettleman Hills and the large production from the deep zones at Santa Fe Springs, Long Beach, and Elwood, these four oils may properly be taken as representative of California crude oils of the lighter or more paraffinic type. The differences in paraffinic characteristics between them are relatively small, and the Santa Fe Springs deep-zone crude oil of about 35° API. may be taken as typical. This oil on non-cracking distillation will give yields about as follows: gasoline 35%; gas oil 30%; lubricating distillate 20%; asphalt, of zero penetration and 200° F. softening-point, 15%. If desired, the heavier ends of the gasoline and the light ends of the gas oil can be combined to give a yield of about 15% of kerosine. The 425° F. F.B.P. straight-run gasoline, without addition of natural gasoline, has a typical octane number of 58, and the gas oil has a pour-point of about 30° F. If instead of distillation to asphalt, the distillation is stopped at a fuel-oil residue of 100 sec. Saybolt Furol at 122° F., the yield of gas oil will be about 25% and of fuel oil about 40%. This fuel oil will have an upper pour-point of about 75° F. The lubricating distillate from typical Santa Fe Springs crude oil has a viscosity-gravity constant of about 0.865 and, on dewaxing, a viscosity-gravity constant of about 0.870. The average wax content of the lubricating distillate is about 10%. Typical yields in moderately selective solvent extraction of the dewaxed lubricating distillate are: 38% of highly aromatic fractions of about 0.95 viscosity-gravity constant, 14% of naphthenic fractions of about 0.86 viscosity-gravity constant, and 48% of paraffinic-type lubricating oil of 0.807 viscosity-gravity constant and about 90 viscosity index.

The more highly paraffinic character of this crude oil is shown not only in the lower octane number of the gasoline, but also by the composition of the naphtha of 200 to 300° F. boiling-range. From aniline-point data it is estimated that the naphtha contains about 10% aromatic, 40% naphthenic, and 50% paraffinic hydrocarbons.

The light crude oils of the Santa Fe Springs type are further characterized by a generally lower sulphur content than the heavier San Joaquin Valley crude oils. Typical values for sulphur contents of the various fractions are: gasoline 0.04%, gas oil 0.40%, lubricating distillate 0.65%, fuel oil 0.75%, and asphalt 0.9%. Because of the bearing of sulphur content on the refining processes required and the suitability of the products for various uses, it may be of interest to mention some of the high sulphur crude oils of California. The most important high sulphur fields at present are Santa Maria, discovered in 1901, and Playa Del Rey or Venice, discovered in 1929. Probably the crude oil highest in sulphur content is that from the Cat Canyon section of the Santa Maria field. This section, which was discovered in 1908, yields a very heavy oil of about 12° API., with a sulphur content of about 4%. The typical Santa Maria and Playa Del Rey crude oils yield straight-run gasoline of about 0.5% sulphur content and fuel oils of about 4% and 3.5% sulphur contents, respectively. Only a very small proportion of the sulphur in these gasolines is present as mercaptans, and certain Playa Del Rey gasolines may even be found negative to the doctor test. The lubricating distillates from both of these crude oils are intermediate in paraffinity between the heavy San Joaquin

Valley and the light Santa Fe Springs and Kettleman Hills types.

Detailed information concerning the characteristics of the crude oils produced from different zones in the various fields is not available. An attempt has been made, however, as far as the data permit, to present values for a crude oil of typical gravity and for crude oils representing approximately the lightest and heaviest oils produced in each field. As a general rule the heavier crude oils are derived from the upper and geologically more recent zones, while the deeper zones yield oils of higher API. gravity and greater paraffinity. Thus, for example, in the Santa Fe Springs field, crude oil of markedly different properties is obtained from the different zones. The crude oil from the Foix zone (3,450-3,525 ft.) yields gasoline and gas oil of predominantly naphthenic character and essentially similar to fractions from San Joaquin Valley heavy crude oil. The oils from the Bell zone (3,560-3,700 ft.) are intermediate in characteristics, while the oils from the deeper Meyer, Nordstrom, Buckbee, O'Connell, and Clark-Hathaway zones (4,070-8,000 ft.) are typical Los Angeles Basin light crude oils.

To show the relative importance of the various oilfields of California, data are presented in Table I for the average production of these fields in 1933, the total production to the end of that year, and the estimated future production. In this table is also given the approximate range of gravity for the crude oils from each field.

In Table II, data are presented on the content of gasoline, gas oil, and fuel oil in the more important of these crude oils, based on analyses carried out in the laboratories of the Union Oil Company of California. The yields shown are considered indicative of those obtainable by straight-run distillation under conditions of moderately good fractionation. In producing the maximum yield of 425° F. F.B.P. gasoline, no substantial production of kerosine distillate of suitably low viscosity is obtainable from these California crude oils; but, if desired, kerosine distillate can be produced as an intermediate fraction with a reduction in yield of both gasoline and gas oil. An indication of the paraffinity of the crude oils is given by the viscosity-gravity constants of the gas oils. The viscosity-gravity constants of the lubricating distillates may be expected to be somewhat higher. The differences are usually in the range of 0.005 to 0.020.

In Table III, data are presented for certain of the crude oils which have been analysed for content of lubricating oil and asphalt in the laboratories of the Union Oil Company of California. In this analysis the sample is topped and the residue steam distilled in approximately 2% cuts. The viscosity, gravity, and pour-point of the cuts are determined, and the yields of lubricating distillate of various viscosity ranges estimated.

In Table IV supplementary data from the published reports of the United States Bureau of Mines are presented for crude oils not included in the other tables. In both Tables III and IV, the viscosity-gravity constant of the lubricating distillate has been included.

The data given in the tables serve to show the wide variety of crude oils produced in California. It will be seen, for example, that the gravities range from 62.1° API. for one Kettleman Hills sample to 6.8° API. for crude oil from Casmla, and the viscosity-gravity constants shown range from 0.836 to 0.939. With such a wide range of characteristics both in content of various fractions and in the properties of these fractions, considerable choice is possible in the selection of crude oils for various uses.

TABLE I
Production Data for California Oilfields

Division, District, and Field	Discovery* Date	Gravity Range ° API, at 60° F.	Analytical Data or shown in Table No.	Proved* Acreage	Producing Wells Dec. 1933	Average* Well depth ft.	Average* Production 1933 bbl. per day	Total Production* to 1 Jan. 1934 million barrels	Estimated* Future Production million barrels
SAN JOAQUIN VALLEY DIVISION:									
Collings	1896			14,669	879	..	11,915	327.2	60.8
Oil City	1896	37	IV
East	1900	16-35	II, IV	..	257	2,088	5,974
West	1901	13-17	II, III	..	1,580	622	1,841
Elk Hills	1919	9,850	217	3,105	12,268	128.6	201.4
Eastern	1920	25-35	IV
Central	1919	15-27	III
Fruitvale	1928	20-23	II	1,220	67	3,950	4,536	5.8	25.2
Kern River	1899	10,023	1,098	..	8,612	293.0	57.0
Edison	1928	14-30	II	3,980	0
Kern Front (Poso Creek)	1913	14	III, IV	..	285	2,180	6,462
Kern River	1899	813	838	2,250
Kettleman Middle Dome	1932	31-8	..	1,280	61	815	416	0.2	39.8
Kettleman North Dome	1928	33-63	II, IV	17,610	61	8,150	58,869	69.3	1,430.7
Lost Hills-Bridges	1911	4,775	4	..	8,766	71.1	..
Bridges	1911	117	..	7,838
North	1912
Shallow	1912	20-30	IV	1,760
Deep	1930	28-46	II, IV	5,833
South	1911	16-26	II, III	873
East Hills	1910	14-35	II, IV	..	194	1,185	928
McKittrick	1898	11-19	III, IV	1,710	192	1,185	1,702	82.7	12.3
Midway-Mariocopa	1894	48,600	2,351	2,050	47,978	11.8	202.8
Buena Vista Hills	1910	24-28
Hovey Hills	1921	14	II
Mariocopa Flat	1928	12-31	II, IV
Midway	1901	12-28	II, III, IV
Sunset	1894	19-28	II, III, IV
Mount Poso	1926	14-18	II, III	1,360	115	1,889	8,164	14.8	52.2
Mountain View	1930	11-34	..	1,200	6	5,836	626	0.2	34.8
Round Mountain	1927	1,001	39	..	2,998	3.8	36.2
Coltes Canyon	1927	14-17	III	25	1,650	2,889
Round Mountain	1927	14-23	II, III	..	14	1,924	509
Wheeler Ridge	1922	21-28	..	320	34	2,717	463	2.9	2.1
Other fields	72
San Joaquin Valley Division	1894	113,618	5,375	..	167,435	1,746.8	2379.2
COASTAL DIVISION									
Capitan	1929	20-29	..	120	6	1,556	80	0.1	11.9
Elwood	1927	36-42	II, IV	400	58	3,482	13,462	45.8	44.2
Rincon	1927	31-31	..	350	5	3,358	1,860
San Miguelito	1931	23-29	..	200	2	7,650	1,068	0.7	24.3
Santa Barbara	1929	18-22	..	80	14	2,124	640	0.5	..
Santa Maria	1901	10,687	189	2,941	3,777	189.6	50.4
Arroyo Grande	1917	10-15	IV
Casmalia	1917	7-14
Lat Canyon	1908	10-16	III, IV
Gato Ridge	1931	11-13
Huana	1929
Lompoc	1903	18-22	II
Orcutt	1901	17-29	II, III, IV
Santa Maria Valley	1934	14-18
Summerland	1894	13-18	IV ..	120	30	830	83	3.1	0.4
Ventura Avenue	1916	26-48	IV ..	1,760	180	6,409	34,413	142.4	147.6
Ventura-Newhall	1875	4,685	404	1,413	3,241	51.1	13.9
Conejo	1898	13-17	IV
Ojai	1885	14-28	IV
Newhall	1875	20-40	II, III
Piru	1882	12
Santa Paula	1887	17-28	II, IV
Sequo	1887	20-33	II
Simi	1910	16-33	II, IV
South Mountain	1916	25-30	II, IV
Watsonville	1878	44	..	100	7	1,268	50	0.8	0.7
Coastal Division	1875	18,472	1,005	..	58,274	379.4	302.1
LOS ANGELES BASIN DIVISION:									
Brea-Olinda (Fullerton)	1880	1,410	293	2,666	8,050	146.8	53.2
Brea Canyon	1899	17-29	II, III	..	73	3,463	6,038
Olinda	1897	13-20	220	2,383	2,012
Puente	1880	0	1,355
Coyote	1909	1,825	161	1,893	10,094	135.4	64.6
East	1911	15-26	II, III	..	81	3,432	1,530
West	1909	15-26	II, III	..	80	4,212	8,544
Dominguez	1923	26-40	..	665	80	4,531	18,538	63.2	61.8
Huntington Beach	1920	15-33	II, III	1,845	524	4,067	35,546	202.6	62.4
Inglewood	1924	20-40	IV ..	865	224	5,482	11,109	88.7	96.3
Lawndale	1928	20-25	..	13	7	5,841	214
Long Beach	1921	18-31	II, III	1,305	1,045	2,416	66,835	502.2	177.8
Los Angeles-Salt Lake	1892	15	IV	171	990	6,239	64.3	..
Montebello	1917	14-31	II, III	1,078	186	2,593	2,990	9.1	11.9
Newport	1923	9-13	III, IV	52	0	311	10,970	0.1	0.1
Playa del Rey (Venice)	1929	26-26	II, IV	320	189	5,191	2,425	24.5	23.5
Potrero (Cyprus)	1928	30-47	..	113	11	5,692	380	1.8	1.2
Richfield	1918	1,278	254	4,095	6,619	71.8	18.2
Yorba	1918	15
Richfield	1919	15-27	II, III
Rosecrans	1924	30-44	..	310	79	4,495	2,927	..	6.7
Santa Fe Springs	1919	04-42	II, III, IV	1,198	574	4,944	49,944	370.9	72.1
Seal Beach (Alamitos Heights)	1926	20-25	IV ..	440	132	5,513	10,886	65.3	34.7
Torrance	1922	3,835	500	3,693	6,389	75.2	14.8
Torrance	1922	18-26	II, III
Hermosa	1930	14-18
Whittier	1898	18-30	IV ..	575	162	2,991	1,101	15.9	4.1
Other fields	45	..	200
Los Angeles Basin Division	1880	18,057	4,607	..	245,531	1,951.0	708.0
CALIFORNIA	150,147	10,987	..	471,260	4,077.2	3,389.3

* Petroleum World Annual Statistical Review, pp. 96-103 (1934).

† Report of Oil Units, California Crude Oil Production and Condemned Volume, Appendix Tables II and XII (1933).

‡ Based on data from Colom, R. E., Petroleum World Annual Statistical Review, p. 30 (1934).

Analytical Examination of California Crude Oils for

Division and District	Field	Saybolt Viscosity				Gasoline Nominal 425° F. F.B.P.							
		Grav. API. at 60° F.	Unsat. at 100° F. Sec.	Furcal at 122° F. Sec.	Sulphur % by wt.	Yield % by vol.	Grav. API. at 60° F.	Engler Distillation, °F.					
								I.B.P.	10%	50%	90%	F.B.P.	A.B.P.
SAN JOAQUIN VALLEY DIVISION:													
Cosiing	East	27.2	63	..	0-49	2-61	49-6	138	212	301	388	420	296
	West	16.7	953	..	0-81	4-4	39-6	242	323	367	403	422	359
Fruitvale	Fruitvale	13.5	..	158	0-79	3-9	41-0	153	310	381	414	428	358
	Kern River	22.1	225	..	0-67	10-4	41-6	204	280	350	404	435	342
Kettleman North Dome	Edson	21.3	288	..	0-60	1-23	45-8	171	266	330	387	420	322
		17.0	0-70	4-6	40-6	245	333	375	409	428	367
Kettleman North Dome		14.7	..	138	0-68	2-5	41-6	164	271	367	404	444	344
		50.2	32	..	0-14	73-9	59-6	105	163	240	358	423	251
Lost Hills - Belridge		38.2	37	..	0-34	45-5	56-2	104	150	264	390	430	270
		33-6	48	..	0-49	37-7	54-2	110	180	276	385	428	279
Lost Hills - Belridge	Belridge North Deep	45.0	32	..	0-08	65-5	52-9	118	192	284	400	436	286
		37.8	35	..	0-20	45-2	50-6	125	210	298	387	418	294
Midway-Maricopa	Belridge South	16.1	..	103	1-00	6-5	39-9	254	323	371	405	424	360
	Buena Vista Hills	25.1	74	..	0-58	29-8	47-1	176	230	294	389	416	300
Hovey Hills		13-6	..	150	1-30	6-8	40-9	230	308	360	406	432	354
	Maricopa Flat	31.1	51	..	0-62	35-0	54-4	109	174	271	383	428	273
Midway		18.3	602	..	1-04	11-6	42-7	210	268	330	387	423	327
		28-0	55	..	0-57	36-5	48-4	168	218	290	380	417	284
Sunset		20.0	247	..	0-76	15-3	42-8	190	266	333	403	420	330
		14.9	..	105	1-05	6-3	40-9	170	303	360	404	424	348
Mount Poso		21-6	..	90	0-61	33-0	48-3	146	214	295	389	423	296
		24-6	108	..	0-87	2-7	47-7	106	237	299	389	424	378
Mount Poso		16.3	..	74	0-50	2-2	38-2	208	340	396	422	434	286
		17-0	..	90	0-70	2-2	38-5	170	267	352	414	433	375
Mountain View		33-8	43	..	0-43	39-8	46-6	115	170	266	382	422	270
		26.7	74	..	0-51	25-4	49-2	130	218	310	403	433	305
Round Mountain		22-0	146	..	0-40	10-1	41-0	269	317	389	427	410	277
		20-5	207	..	0-54	7-5	41-4	225	311	354	392	420	348
COASTAL DIVISION:													
Elwood	Elwood	41.8	0-10	58-6	48-0	160	236	330	408	444	326
		36-0	0-42	44-4	51-2	163	224	297	387	434	296
Santa Maria	Lompoc	20-4	..	54	4-20	25-2	53-1	116	200	306	406	430	300
		18-8	622	..	3-78	34-3	46-3	137	239	317	395	425	321
Orcutt		23-8	76	..	1-85	32-6	52-5	127	198	289	390	423	289
		23-8	209	..	2-49	23-7	52-4	120	198	304	392	426	296
Ventura-Newhall	Newhall	19-9	1212	..	3-85	31-4	53-6	124	181	292	400	432	286
		22-4	65	..	0-27	31-7	53-1	125	207	294	384	422	291
Santa Paula		27-1	146	..	0-65	35-9	51-1	138	205	290	382	419	290
		22-0	220	..	0-28	32-3	47-7	158	231	312	389	422	308
Sespe		25-5	265	..	3-27	23-1	53-2	113	192	292	395	428	290
		17-2	..	53	1-43	17-4	45-9	147	249	330	404	430	321
Simi		32-7	56	..	0-34	33-0	53-4	140	207	295	390	424	294
		20-7	394	..	0-69	19-3	49-8	139	216	307	393	432	303
South Mountain		28-6	128	..	0-99	29-4	51-7	130	240	305	400	432	305
		21-1	321	..	2-00	20-3	48-2	156	235	320	394	430	313
	28-1	74	..	1-80	30-3	55-8	114	180	278	376	418	278	
LOS ANGELES BASIN DIVISION:													
Brea-Olinda	Brea Canyon	28-9	65	..	0-62	31-9	51-5	119	190	278	385	415	280
		17-1	..	36	1-57	19-3	47-2	125	260	323	393	423	321
Coyote	Olinda	20-4	..	207	1-73	12-0	43-8	206	272	327	386	428	326
	East	25-4	177	..	1-52	23-9	49-8	116	195	281	381	422	282
Huntinguez	West	24-0	201	..	1-64	18-5	52-7	144	222	318	383	423	319
		17-4	..	206	1-71	7-1	43-8	142	280	336	388	415	325
Huntinguez Beach	Dominguez	33-9	48	..	0-81	40-7	53-3	120	188	272	373	427	275
		26-7	103	..	0-90	33-4	50-4	136	222	300	380	416	293
Long Beach	Huntinguez Beach	22-8	239	..	1-36	24-3	48-8	139	220	294	386	420	294
		19-3	461	..	2-50	15-8	46-6	200	248	308	384	423	311
Montebello	Long Beach	20-4	39	..	0-88	35-1	54-6	100	172	270	378	420	271
		26-4	101	..	1-13	26-4	48-7	114	192	284	382	420	307
Playa del Rey	Montebello	23-3	251	..	1-54	20-2	50-4	132	216	304	386	424	300
		28-6	59	..	0-46	26-4	45-4	180	238	312	392	426	311
Richfield	Montebello	22-8	176	..	0-80	19-3	41-3	214	312	390	386	424	344
		17-2	81	..	1-19	3-2	40-4	161	292	366	403	420	348
Rosecrans	Playa del Rey	26-3	81	..	2-30	30-8	56-2	106	166	263	375	420	266
		24-4	119	..	2-62	20-1	52-1	122	289	389	423	426	284
Santa Fe Springs	Richfield	21-4	292	..	2-88	22-8	47-0	165	251	326	390	428	318
		23-8	284	..	1-19	21-9	49-8	164	230	302	376	418	300
Torrance	Richfield	19-8	0-60	24-3	48-7	142	232	312	392	420	307
		15-6	..	104	1-02	6-0	42-9	189	288	348	390	424	338
Torrance	Rosecrans	40-8	0-39	61-1	53-5	136	198	273	376	416	279
		35-5	40	..	0-56	45-0	51-3	142	232	300	380	416	292
Torrance	Santa Fe Springs	30-3	52	..	0-51	29-8	48-8	180	242	305	380	416	306
		28-0	41	..	0-39	43-8	44-7	106	178	274	378	420	275
Torrance	Santa Fe Springs	32-3	45	..	0-30	33-3	49-4	140	212	312	392	420	304
		28-0	73	..	0-57	24-8	46-3	188	250	315	384	418	313
Torrance	Hermosa	16-9	..	91	2-74	7-3	43-4	172	272	348	396	424	334
		25-9	120	..	1-35	22-3	48-5	172	240	307	380	424	307
	20-9	423	..	2-08	15-1	47-5	145	237	322	390	421	312	

* Analytical data from laboratories of Union Oil Company of California.

† A. S. I. M. Method D. 357-34 °F.

‡ Moore, C. C., Jr., and Kaye, G. R., *Oil and Gas J.* 33, 110-11 (1934).

Gasoline and Gas Oil Contents and Characteristics*

Sulphur by wt.	Octane Number	Yield % by vol.	Gas Oil Nominal 700° F. F.B.P.										Residuum			
			Grav. API. at 60° F.	F.B.P. ° F.	A.B.P. ° F.	Viscosity Say. Univ. at 100° F. Sec.	Sulphur by wt.	Pour-point ° F.	Aniline P. ° F.	Vis. % const.	Yield % by vol.	Grav. API. at 122° F.	Sulphur at 210° F.	Sulphur by wt.	Pour-point ° F.	
0-01	60-0	30-5	29-6	724	566	45	0-40	35	146	0-859	23-4	6-4	212	0-68	80	
0-10	58-0	34-5	24-5	699	525	48	0-50	0	126	0-858	25-4	10-9	61	0-90	60	
0-16	63-0	38-1	23-7	710	590	55	0-51	0	126	0-889	58-0	8-1	125	0-95	20	
0-07	69-0	42-8	28-6	692	586	44	0-50	25	142	0-866	46-8	13-9	25	0-89	50	
0-02	65-5	40-2	27-0	706	577	46	0-48	0	138	0-874	47-5	11-5	82	0-80	30	
0-04	..	29-9	26-2	690	576	41	0-46	0	135	0-885	65-5	12-0	45	0-82	15	
0-10	57-0	31-3	24-5	691	579	53	0-47	0	132	0-885	66-2	10-3	74	0-80	0	
0-01	57-0	30-0	26-1	
0-03	55-5	27-8	34-3	726	560	39	0-21	10	159	0-841	26-7	17-0	..	0-67	95	
0-01	50-0	34-8	32-8	699	573	42	0-51	30	154	0-844	27-5	13-2	34	0-90	60	
..	..	23-1	11-4	
0-02	53-0	44-5	34-3	692	558	37	0-18	15	158	0-841	10-3	14-6	377	26	0-61	90
0-20	64-5	38-5	23-5	702	575	50	0-64	0	115	0-840	55-0	7-8	268	1-25	15	
0-06	68-0	32-3	28-0	693	560	44	0-49	0	127	0-879	37-9	11-9	55	1-09	10	
0-28	..	36-5	22-0	734	601	70	1-05	0	113	0-896	56-7	6-6	822	1-49	15	
0-06	60-0	31-7	30-4	695	583	44	0-74	35	147	0-855	33-3	11-9	..	4-92	65	
0-10	67-0	34-9	25-8	685	576	45	0-86	0	122	0-862	53-5	11-4	930	2-13	20	
0-13	61-5	34-5	30-1	698	547	39	0-55	0	129	0-865	29-0	11-4	245	0-78	20	
0-04	62-5	36-9	25-4	693	582	45	0-49	0	120	0-885	47-8	11-1	..	10-07	15	
0-20	66-0	37-6	23-1	696	584	46	0-76	0	115	0-896	56-1	8-7	178	2-34	30	
0-04	65-0	32-8	27-9	691	567	43	0-61	0	131	0-872	34-2	11-8	..	58	0-96	15
0-05	64-5	35-2	26-5	692	567	45	0-53	0	129	0-878	37-7	10-3	..	82	1-12	15
..	..	3-3	94-5	
..	..	0-5	97-3	
0-01	61-0	30-3	31-5	704	575	41	0-46	25	151	0-853	29-9	12-0	..	38	0-83	90
0-02	60-0	38-6	..	705	580	43	0-54	0	153	0-864	36-0	11-2	..	57	0-80	80
0-05	68-0	49-9	25-9	704	583	46	0-29	0	133	0-881	39-9	14-0	406	0-76	15	
0-06	70-0	47-3	26-8	693	571	44	0-40	0	131	0-879	45-2	12-5	..	32	0-75	20
..	..	32-5	8-9	
..	..	24-9	30-7	
0-49	48-0	27-8	28-3	698	576	43	2-88	20	131	0-969	47-0	6-5	..	390	5-54	10
0-43	60-0	26-6	24-9	696	575	44	2-58	0	110	0-889	49-1	6-5	..	504	5-29	<0
0-20	51-0	31-3	27-1	701	577	45	1-21	0	151	0-850	36-4	9-7	930	5-70	20	
0-33	31-5	36-3	20-3	730	577	45	2-16	25	140	0-862	42-2	10-7	300	2-67	10	
0-67	51-5	26-3	28-7	725	587	44	3-06	30	140	0-866	52-3	5-8	964	9-8	4-92	45
0-11	46-0	35-1	30-8	705	583	46	0-19	35	164	0-846	33-2	11-5	..	98	0-52	65
0-06	62-0	34-8	25-9	706	578	46	0-55	0	127	0-881	29-3	11-3	..	111	1-08	15
0-07	63-0	34-9	25-5	694	574	45	0-84	0	117	0-884	38-5	8-6	..	147	1-23	15
0-70	48-0	32-9	30-7	691	567	41	2-44	25	126	0-858	44-0	9-6	..	216	3-69	30
0-21	63-0	29-8	23-5	702	583	47	1-34	0	106	0-895	52-3	7-3	..	229	1-60	20
0-03	48-5	31-8	34-3	710	564	40	0-29	25	161	0-839	35-2	14-8	326	0-48	63	
0-05	58-5	35-6	26-5	690	564	43	0-57	0	126	0-880	45-1	8-2	..	218	0-89	5
0-08	50-0	33-6	30-9	704	587	44	0-87	30	153	0-852	37-0	11-5	..	151	1-61	60
0-15	55-0	31-3	27-1	696	575	42	1-41	0	120	0-877	48-4	7-8	..	295	2-50	10
0-18	53-0	33-8	31-6	695	570	42	1-54	25	147	0-852	35-9	11-0	..	55	2-54	55
0-06	63-0	30-4	30-8	716	579	42	0-55	25	150	0-855	37-7	10-9	..	83	1-00	65
0-15	64-0	33-4	29-4	696	572	43	1-42	15	136	0-863	47-6	11-0	..	69	2-05	55
0-21	64-5	30-2	26-6	692	575	44	1-50	0	122	0-874	57-8	8-7	..	305	1-96	15
0-13	63-5	30-8	28-5	695	573	43	1-23	20	143	0-868	46-3	10-2	..	39	1-67	60
0-17	61-0	32-7	30-1	705	568	42	1-30	15	138	0-859	49-1	11-7	..	84	2-17	60
0-29	64-0	38-5	30-2	692	562	40	1-56	0	134	0-863	54-4	10-7	..	92	1-81	45
0-09	56-0	32-8	32-9	702	564	41	0-71	25	154	0-845	30-5	13-1	367	27	1-42	65
0-07	56-0	33-1	32-7	696	571	41	0-88	25	153	0-846	33-5	14-0	..	91	1-53	65
0-17	61-0	31-4	29-9	695	577	44	1-28	20	144	0-858	39-8	10-6	..	91	1-71	60
0-20	62-5	30-8	29-8	696	579	43	1-21	20	143	0-860	44-9	9-5	..	170	1-76	40
0-23	68-0	29-0	29-5	692	580	43	2-17	0	133	0-861	55-2	9-2	..	105	2-96	30
0-14	60-0	29-1	31-0	718	580	45	0-69	25	156	0-849	38-7	11-2	..	186	3-70	60
0-07	57-5	31-7	30-1	700	581	43	0-99	5	148	0-858	41-4	10-2	..	120	1-67	50
0-11	59-5	30-9	30-3	695	576	43	1-14	0	145	0-856	48-9	11-3	..	108	1-98	50
0-05	65-0	37-1	30-6	727	585	46	0-46	30	166	0-855	35-5	11-5	213	73	0-84	75
0-08	65-0	43-6	28-8	693	572	42	0-46	0	136	0-867	46-1	14-4	354	..	1-16	60
0-25	64-0	40-6	25-2	709	597	53	0-73	0	134	0-861	56-2	10-8	..	67	1-40	10
0-47	61-0	31-5	31-9	730	593	45	2-09	0	133	0-870	37-7	10-0	..	438	2-70	45
0-54	56-0	33-6	30-1	700	566	41	2-42	20	130	0-881	40-0	8-5	..	109	3-40	40
0-76	49-5	31-0	28-7	692	581	42	2-49	30	132	0-868	46-2	8-8	..	84	3-38	50
0-13	58-5	36-6	31-0	692	574	42	0-97	25	145	0-876	54-5	11-2	..	111	1-59	55
0-38	58-0	31-1	28-9	692	580	43	2-16	10	129	0-866	46-5	9-5	..	62	3-27	40
0-19	66-5	34-4	27-0	696	584	48	0-65	35	136	0-872	59-9	7-8	..	490	1-23	10
0-05	55-0	38-1	30-6	727	583	46	0-46	20	160	0-838	36-5	15-7	..	190	0-92	15
0-08	53-0	30-8	33-8	695	566	40	0-45	15	148	0-842	24-2	12-8	..	49	0-88	80
0-09	51-5	35-6	32-9	694	567	40	0-40	25	154	0-847	34-6	14-7	..	34	0-91	95
0-06	56-5	30-9	31-9	695	566	42	0-50	10	156	0-850	37-3	13-2	..	186	3-70	45
0-04	50-0	44-1	31-3	730	590	41	0-31	35	158	0-854	22-0	14-4	309	0-67	75	
0-02	63-0	38-6	31-1	690	566	40	0-41	15	147	0-857	36-6	14-8	..	40	0-97	75
0-78	65-5	34-6	31-0	703	585	45	2-13	0	140	0-876	48-4	10-0	..	190	0-92	15
0-09	52-5	28-1	30-7	690	568	40	0-91	15	140	0-860	46-6	13-1	..	34	0-91	75
0-20	53-0	33-4	29-6	691	573	42	1-41	0	139	0-862	51-5	10-5	..	66	2-58	20

* After blending with 25-35° F. pour-point gas oil of 42 Saybolt Universal seconds viscosity at 100° F. to produce a fuel oil of approximately 85 sec. Saybolt Furol viscosity at 122° F.

TABLE III

Analytical Examination of California Crude Oils for Lubricating Oil Content and Characteristics*

Division and District	Field	Gravity ° API, 60° F.	Viscosity Saybolt Furot at 122° F. Sec.	Analytical Steam Distillation Yield, % by Volume					Characteristics of Heavy Lubricating Distillate			
				Light Oils	Light Lubricating Distillate	Medium Lubricating Distillate	Heavy Lubricating Distillate	Extra Heavy Lubricating Distillate	Asphalt 40 pen. at 77° F.	Pour point ° F.	Viscosity- gravity Constant**	
SAN JOAQUIN VALLEY DIVISION:												
Coalinga	West	16.5	39	36.8	8.1	12.2	7.8	8.1	26.5	25	0-912	
Elk Hills	Central	17.1	..	58.0	6.0	0.0	8.0	6.0	22.0	10	0-889	
Kern River	Kern River	20.1	..	37.8	6.0	10.0	8.0	6.2	42.3	15	0-900	
Lost Hills-Beiridge	Beiridge South	14.7	..	45.5	6.0	8.0	6.6	0.0	41.6	75	0-905	
McKittrick	McKittrick	15.2	..	28.0	6.0	14.0	8.0	8.2	35.8	20	0-917	
Midway-Maricopa	Midway	27.1	..	54.0	8.0	6.0	6.0	10.0	20.0	25	0-891	
		18.2	..	35.4	10.0	10.0	8.0	12.5	24.1	10	0-900	
	Sunset	12.7	..	18.0	6.0	8.0	10.2	0.0	27.8	-10	0-923	
		25.7	..	46.1	8.0	6.0	6.0	2.7	31.2	80+	0-879	
		18.6	..	34.1	6.0	6.0	10.0	6.9	37.0	0	0-888	
		11.6	..	18.4	8.0	8.0	6.0	1.5	20.0	20	0-924	
Mount Poso	Mount Poso	18.0	69	21.0	15.3	10.3	10.1	13.5	29.8	20	0-906	
Round Mountain	Coffee Canyon	16.0	90	20.7	10.8	10.8	5.4	16.0	36.3	0	0-885	
	Round Mountain	18.0	..	26.5	11.7	13.8	10.0	17.9	20.1	15	0-905	
		19.3	21	40.9	12.0	10.0	8.0	10.8	18.3	45	0-894	
		15.2	..	30.8	10.0	8.0	10.2	12.0	29.0	10	0-908	
COASTAL DIVISION:												
Santa Maria	Cat Canyon	15.0	..	25.0	4.4	4.4	3.9	0.0	62.3	60	0-896	
	Orcutt	21.7	..	36.6	4.0	4.0	6.0	0.0	49.4	65	0-893	
LOS ANGELES BASIN DIVISION:												
Brea-Olinda	Brea Canyon	21.4	..	42.9	8.0	6.0	10.0	1.8	31.3	65	0-887	
	Olinda	13.8	..	34.2	6.0	6.0	10.0	1.9	41.9	40	0-891	
Coyote	East	24.0	..	49.8	6.0	6.0	4.0	1.1	33.1	80+	0-893	
	West	17.8	..	27.7	6.3	10.5	8.4	0.5	46.6	80+	0-889	
Huntington Beach	Huntington Beach	28.9	..	51.5	8.0	6.0	8.0	0.7	25.8	80+	0-875	
		22.9	..	39.1	6.9	6.9	9.2	0.6	37.3	80+	0-877	
		18.9	..	30.0	6.0	6.0	8.9	0.0	49.1	75	0-891	
Long Beach	Long Beach	30.8	..	52.1	6.0	6.0	6.0	2.1	27.8	80+	0-868	
		23.6	..	35.3	6.0	8.0	6.0	2.3	42.4	80+	0-885	
		18.7	..	28.7	6.0	8.0	10.0	2.3	45.0	80+	0-885	
Montebello	Montebello	29.7	..	58.9	8.0	6.0	8.0	1.8	17.3	80+	0-863	
		23.0	..	45.6	8.0	8.0	5.9	0.0	22.5	80+	0-887	
		15.9	..	23.0	6.0	8.0	10.0	9.7	43.3	10	0-886	
Newport	Newport	9.0	..	7.8	6.0	1.9	0.0	0.0	84.3	..	0-903	
Richfield	Richfield	25.0	..	40.2	6.0	6.0	7.8	0.0	40.0	80+	0-886	
		16.7	..	29.9	6.0	10.0	14.0	2.7	37.4	80+	0-883	
Rosecrans	Rosecrans	35.9	..	64.1	2.0	4.0	6.0	0.3	23.6	80+	0-857	
Santa Fe Springs	Santa Fe Springs	41.7	..	83.4	4.0	4.0	4.0	2.2	2.4	80+	0-950	
		33.6	..	65.7	6.0	6.0	6.0	4.5	11.8	75	0-861	
		26.2	..	54.9	8.0	8.0	10.0	2.6	16.5	80+	0-859	
		23.1	..	37.3	6.0	6.0	8.0	3.0	39.7	80+	0-881	
Torrance	Torrance	20.4	..	27.9	6.0	8.0	6.0	2.8	49.3	60	0-884	

* Analytical data from laboratories of Union Oil Company of California.

† Distillate fractions having a viscosity less than 60 sec. Saybolt Universal at 100° F.

‡ Distillate fractions having a viscosity range between 60 and 135 sec. Saybolt Universal at 100° F.

§ Distillate fractions having a viscosity range between 140 sec. Saybolt Universal at 100° F. and 51 sec. Saybolt Universal at 210° F.

|| Distillate fractions having a viscosity range between 52 and 80 sec. Saybolt Universal at 210° F.

¶ Distillate fractions of more than 80 Saybolt Universal sec. viscosity at 210° F., cut to leave a residuum of 40 penetration at 77° F. asphalt.

** Houghton, W. F., and Robb, J. A., *Ind. Eng. Chem. Anal. Ed.* 3, 144-5 (1931).

TABLE IV
Analytical Examination of California Crude Oils*

Division and District	Field	Gravity API, at 60° F.	Viscosity Saybolt Universal at 100° F., Sec.	Sulphur % by Weight	Analytical Distillation Yield, % by Volume							Viscosity- Gravity Constant of Lubricating Distillate††
					Gasoline†	Kero- sine†	Gas Oil†	Non-viscous† Lubricating Distillate	Medium† Lubricating Distillate	Viscous** Lubricating Distillate	Residuum	
SAN JOAQUIN VALLEY DIVISION:												
Coalinga	Oil City	37.2	31	0-10	53-0	0-0	36-8	10-2	0-910††
	East	20-5	178	0-51	6-8	0-0	26-8	11-4	7-3	7-9	19-8	0-903
Elk Hills	Eastern	26-6	68	0-61	24-0	0-0	25-0	7-1	5-7	6-9	31-3	0-891
	Kern River	17-8	690	0-04	0-0	0-0	27-2	7-8	5-9	12-5	46-6	0-899
Kern River	Kern Front	14-2	5,470	0-94	0-0	0-0	12-2	6-5	5-0	15-8	60-5	0-899
	Kern River	13-3	>6,000	1-14	0-0	0-0	16-0	9-9	4-1	13-9	56-1	0-911
Kettleman	Kettleman North	62-1	32	0-10	89-7	7-7	1-6	1-0	0-845††
North Dome	Dome	28-4	52	0-79	33-4	0-0	22-0	6-1	3-8	7-3	27-4	0-889
	Belridge North	30-2	44	0-69	34-5	0-0	24-7	6-3	4-4	6-1	24-0	0-880
Lost Hills-Belridge	Shallow	29-5	53	0-66	31-5	0-0	20-4	7-5	4-6	6-1	29-9	0-874
	Belridge North	16-5	525	0-85	5-1	0-0	19-0	8-8	5-5	12-4	49-2	0-920
McKittrick	Deep	18-6	330	0-91	11-1	0-0	22-3	7-1	5-9	14-4	39-2	0-910
	McKittrick	15-1	1,600	1-02	2-1	0-0	19-9	6-9	6-6	17-2	47-3	0-910
Midway-Maricopa	Maricopa Flat	26-6	79	0-68	24-1	0-0	21-5	7-1	5-2	8-9	33-2	0-870
	Midway	12-5	>6,000	1-29	0-0	0-0	16-6	5-3	5-0	18-3	54-8	0-912
Sunset	Midway	19-7	265	0-92	9-6	0-0	23-7	7-2	4-7	14-4	40-4	0-902
	Sunset	11-9	>6,000	1-53	0-0	0-0	10-2	7-7	5-4	19-9	56-8	0-910
	Sunset	29-7	162	0-73	17-0	0-0	26-9	7-5	6-3	8-5	33-8	0-898
		12-7	>6,000	1-16	0-0	0-0	19-3	5-2	5-5	20-9	49-1	0-907
COASTAL DIVISION:												
Elwood	Elwood	38-0	37	0-18	40-1	7-0	23-1	7-7	4-4	1-2	16-5	0-856
	Atroyo Grande	14-8	3,840	1-30	5-3	0-0	17-3	6-2	4-2	11-9	55-1	0-898
Santa Maria	Carmalita	6-8	1,870§	2-84	0-0	0-0	26-8	2-0	12-7	7-6	50-9	0-939
	Cat Canyon	15-9	3,800	4-13	9-8	0-0	25-5	5-6	5-6	7-8	45-7	0-897
Summerland	Orcutt	21-0	252	2-83	21-8	0-0	21-2	6-6	4-5	5-7	40-2	0-888
	Summerland	13-6	2,940	0-54	0-0	0-0	14-8	6-6	5-5	13-1	60-0	0-927
Ventura Avenue	Ventura Avenue	46-7	32	0-47	64-4	15-9	8-1	11-6	0-836††
	Ventura Avenue	30-6	67	1-20	27-0	4-3	16-7	8-2	5-4	..	35-9	0-874
Ventura-Newhall	Conejo	14-4	3,990	0-52	0-0	0-0	11-0	8-4	7-6	20-7	52-3	0-892
	Ojai	17-1	890	1-63	13-0	0-0	18-6	6-5	4-6	10-9	46-4	0-912
Watsonville	Santa Paula	22-6	114	0-55	13-1	0-0	29-5	7-4	3-6	12-4	34-0	0-896
	Simi	32-3	47	0-68	32-9	5-2	18-9	7-4	4-6	5-4	23-6	0-874
Watsonville	South Mountain	28-2	86	1-73	25-5	4-5	16-9	8-7	7-0	2-1	35-3	0-869
	Watsonville	44-3	32	0-19	60-4	6-1	14-6	4-9	3-0	3-9	7-1	0-868
LOS ANGELES BASIN DIVISION:												
Inglewood	Inglewood	20-7	240	2-12	17-0	0-0	21-9	6-9	4-8	9-1	40-3	0-903
	Los Angeles-Salt Lake	14-8	2,550	2-73	8-3	0-0	12-8	6-0	7-1	13-5	52-3	0-910
Newport	Newport	12-3	>6,000	1-99	0-0	0-0	9-5	5-3	4-0	12-0	69-2	0-910
	Plays del Rey	24-7	115	2-60	23-6	3-6	16-4	7-6	4-7	5-5	38-6	0-890
Santa Fe Springs	Santa Fe Springs	34-2	41	0-26	32-1	6-5	21-3	10-6	5-5	2-3	21-7	0-857
	Santa Fe Springs	34-2	42	0-45	35-4	5-1	19-0	9-9	3-6	4-0	23-0	0-859
Seal Beach	Seal Beach	27-9	60	0-54	18-8	0-0	30-8	10-2	4-8	5-8	29-6	0-866
	Whittier	24-2	159	1-23	16-0	4-6	17-4	10-0	5-9	2-7	43-4	0-874
Whittier	Whittier	23-0	104	0-56	18-8	0-0	26-4	6-5	4-7	10-3	33-3	0-900

Analytical data from U. S. Bureau of Mines Reports of Investigations No. 2595, 2608, 2846, and 3074.

† Fractions distilling at atmospheric pressure below 392° F. and lighter in gravity than 40-0° API.

‡ Fractions distilling at atmospheric pressure above 392° F. but below 527° F. and lighter in gravity than 40-0° API.

§ Fractions heavier than 40-0° API, distilling at atmospheric pressure below 527° F. plus all vacuum distillate fractions having a viscosity less than 50 sec. Saybolt Universal at 100° F.

|| Distillate with a viscosity range between 50 and 100 sec. Saybolt Universal at 100° F.

¶ Distillate with a viscosity range between 100 and 200 sec. Saybolt Universal at 100° F.

** Distillate of more than 200 sec. Saybolt Universal viscosity at 100° F. distilling below 572° F. at 40 mm. pressure.

†† Calculated from viscosity at 100° F. of distillate fraction nearest 200 sec. Saybolt Universal viscosity at 100° F., using formula given by Moore, C. C., Jr., and Kaye, G. R., *Oil and Gas J.* 33, 110-11 (1934).

‡‡ Determined on gas oil fraction.

§§ Saybolt Universal viscosity at 210° F.

GULF COAST

By A. J. KRAEMER, B.Sc., A.S.T.M.

Senior Refinery Engineer, U.S. Bureau of Mines

Introduction

THE Gulf Coast of Texas and Louisiana came into prominence as an oil-producing region following the discovery of 'gusher' production by Captain Lucas near Beaumont in the Spindletop field, Jefferson County, marking the beginning of important oil operations in Texas in 1901. During that same year oil was discovered in the Jennings Salt-dome, Acadia Parish, Louisiana. In recent years many producing oilfields and recognized although untested domes have been discovered largely by means of geophysical methods. The great thickness of the sedimentary rocks, the complicated structural conditions on and around the flanks of the salt cores, and the prolific production that has been obtained from some of the old fields combine to raise to high peaks the speculative interest in the future potential possibilities of this extensive area, and particularly to create an interest regarding the quality of the oil that may be anticipated in the different possible producing horizons of the many fields.

Tabulated data are given by B. C. Craft [1, 1937] and by W. V. Vietti and E. P. Hayes [12, 1937] in *Petroleum Development and Technology* 1937, for 46 fields in southern Louisiana and 156 fields in the Texas Gulf Coast district; in addition to other data, these tabulations give production during 1935 and 1936 and the total production for each field through 1936. The compilations show that 267,363,000 barrels of petroleum had been produced from the Louisiana Gulf Coast fields to the end of 1936, and 1,096,175,000 barrels from fields of the Texas Gulf Coast district, or a total production for the entire Gulf Coast district from 1901 through 1936 of 1,363,538,000 barrels. Production in 1935 and 1936 as stated by Craft and by Vietti and Hayes, with percentage of increase, was as follows:

	1935 Barrels	1936 Barrels	Increase %
Louisiana Gulf Coast	40,874,084	52,968,632	29.6
Texas Gulf Coast	69,597,811	91,224,844	31.1
Total	110,471,895	144,193,476	30.5

The most prolific fields in the Gulf Coast district to the end of 1936 were Spindletop, with a production of 123 million barrels, and Humble, with more than 121 million barrels. Jennings, with a production of 52 million barrels of oil to the end of 1936, and Vinton with 42 million barrels were the most prolific of the Louisiana Gulf Coast fields. The largest producing field during 1936 was Conroe, which produced nearly 15 million barrels of oil.

Characteristics of Gulf Coast Petroleum. Gulf Coast crude oils usually are considered to be naphthene-base oils, and are often referred to as asphalt-base oils. Data presented in this article indicate that both of these opinions are inaccurate as to many of the oils. Although most of the oils are classed as naphthene base, intermediate characteristics are ascribed to many of them, and a few have paraffinic characteristics, aside from the presence of paraffin wax. The low carbon residue of residuum of many of the oils

indicates that they contain little asphalt. This is indicated also by the colour, which is green or brown rather than black, and by the low sulphur content, which appears to be incompatible with the presence of more than small proportions of asphalt.

The large number of oilfields, coupled with the fact that many of them have from 2 to 8 producing horizons, complicates discussion of Gulf Coast crude oils in a short paper. Practical experience in processing these oils has shown that because of the differences in physical and chemical properties the oil from each field and each stratum presents a separate problem in commercial utilization.

Analysis of Typical Gulf Coast Crude Oils

The United States Bureau of Mines has developed a method of laboratory analysis of crude petroleum which provides a basis for comparison of essential properties. The bureau has analysed more than 130 samples of oils from Gulf Coast fields and has published some of these analyses in full in Bulletin 291 [9, 1928] and in Reports of Investigations 3253 [6, 1934] and 2808 [7, 1927] and others in summary form in Report of Investigations 3252 [13, 1934]. Apparatus and procedure for the analysis are described in Bulletin 207 [2, 1922]. Interpretation of results is discussed in Report of Investigations 2806 [8, 1927] and in Bulletin 291 [9, 1928].

Bureau of Mines Analysis.

The Bureau of Mines apparatus and method of analysis may be described briefly as follows:

A charge of 300 ml. of petroleum is measured or weighed into a 500 ml. Hempel flask similar to the one illustrated in A.S.T.M. method D 285, except that the end of the side outlet is bent vertically downward to accommodate a vertical condenser. No. 18 jack-chain is placed in the neck of the distilling flask as in the A.S.T.M. method. Thermometers certified by the National Bureau of Standards are used, but no corrections for emergent stem, scale error, or barometric pressure are used. All temperatures mentioned in connexion with distillations by the Bureau of Mines method are on this basis. Fractions are taken at each 25° C. interval of the distillation thermometer reading until a temperature of 275° C. is attained. At this point distillation is interrupted and the jack-chain is replaced by 2 or 3 conical 'spray catchers' of wire gauze. Distillation is then continued at an absolute pressure of 40 mm. of mercury until a thermometer reading of 300° C. is reached, at which point distillation is stopped. Fractions are taken at 25° C. intervals, beginning with the fraction obtained at a thermometer reading of 200° C.

Volume and gravity are recorded for the fractions obtained at atmospheric pressure, and volume, gravity, Saybolt Universal viscosity at 100° F., and cloud-point are recorded for the fractions obtained at 40 mm. pressure. Volume, gravity, and Conradson carbon residue are determined for the residuum. Summaries of the analyses, including the more important items, are given in Table I,

accompanying which are notes explaining the methods of deriving the data in the table.

'Base' of a Crude Oil.

Since Bulletin 291 was published, the Bureau has learned (as a result of analysing several hundred additional samples of oil) that the system of classifying crude oils according to 'base' described in that bulletin does not take full account of fundamental differences in oils.

The method used by the United States Bureau of Mines at present is as follows:

1. Note the API. gravity of 'key fraction No. 1', the fraction distilling between 250° and 275° C. (482° and 527° F.) at atmospheric pressure.

2. Note the API. gravity of 'key fraction No. 2', the fraction distilling between 275° and 300° C. (527° and 572° F.) at 40 mm. absolute pressure.

For purposes of classification the gravity of key fraction No. 1 is taken as representing the lighter (lower boiling) fractions of the oil while the gravity of key fraction No. 2 represents the heavier (higher boiling) distillates.

If the gravity of key fraction No. 1 is 40.0° API. or lighter, the lower boiling fractions of the oil are paraffinic in character. If it is 33.0° API. or heavier they are naphthenic, and if it is between 33.0° and 40.0° (33.1 to 39.9° API. inclusive) the lower boiling fractions are intermediate.

Similarly, if the gravity of key fraction No. 2 is 30.0° API. or lighter, the higher boiling fractions of the oil are paraffinic in character. They are naphthenic if key fraction No. 2 is 20.0° API. or heavier and intermediate if the key fraction is between 20.0 and 30.0 (20.1 to 29.9° API. inclusive). Thus it can be seen that there are nine possible classes of crude oils, as follows:

- (1) Paraffin base: Distillates paraffinic throughout.
- (2) Paraffin-intermediate base: Light fractions paraffinic, heavy fractions intermediat.
- (3) Intermediate-paraffin base: Light fractions intermediate, heavy fractions paraffinic.
- (4) Intermediate base: Distillates intermediate throughout.
- (5) Intermediate-naphthene base: Light fractions intermediate, heavy fractions naphthenic.
- (6) Naphthene-intermediate base: Light fractions naphthenic, heavy fractions intermediate.
- (7) Naphthene base: Distillates naphthenic throughout.
- (8) Paraffin-naphthene base: Light fractions paraffinic, heavy fractions naphthenic.
- (9) Naphthene-paraffin base: Light fractions naphthenic, heavy fractions paraffinic.

In two of the above classes (the intermediate-paraffin and the naphthene-intermediate) the change in gravity throughout the distillation range is unusually small. In two other classes (the paraffin-intermediate and intermediate-naphthene) the change in gravity throughout the distillation range is unusually large. In the paraffin-naphthene class the change of gravity would be exceedingly great and in the naphthene-paraffin class exceedingly small. In fact no crude oil has yet been found among the many hundred analysed by the Bureau of Mines which would fall in either of these two classes. For practical purposes, therefore, the classification indicated by the first seven classes would seem adequate.

No mention has yet been made of the presence or absence of wax as affecting the base of a crude oil. Although the presence of wax probably was the original reason for

using the term 'paraffin base', there is no evidence to show that wax is a necessary component of any type of crude oil. In general it can be said that oils whose heavy fractions are paraffinic or intermediate in gravity will be found to contain wax. However, samples are analysed occasionally, at least of intermediate oils, which apparently are wax-free. Some samples of intermediate-naphthene, naphthene-intermediate and naphthene base oils are free from wax while others are wax-bearing. In the intermediate class wax-free oils are unusual. In the naphthene and naphthene-intermediate classes wax-free oils are predominant, while in the intermediate-naphthene class both types of oil are commonly found. To determine the presence or absence of wax, note the 'cloud-point' of 'key fraction No. 2'. If this cloud-point is reported as being below 5° F., it indicates that wax is absent. If, however, the cloud-point is above 5° F., it indicates the presence of wax.

'Grade A' and 'Grade B' Oils.

Originally, Gulf Coast crude oils were divided into two classes, called 'green oil' and 'black oil'. However, for many years Gulf Coast crude oils have been classified commercially as 'Grade A' or 'Grade B'. Posted prices of Gulf Coast crude oils formerly were based upon their classification into these two grades; that is, a flat price for 'Grade A' crude oils and a flat price for 'Grade B' oils was posted by each purchaser. Determination of the classification of crude oil into 'Grade A' or 'Grade B' was made by each company, and apparently the basis for classification was not definitely known outside the particular company making the classification. Available information indicates that to be classified as 'Grade A' a Gulf Coast crude oil must not contain more than a specified maximum quantity of sulphur (usually about 0.30-0.60%) and the lubricating distillates of specified viscosities must meet certain requirements as to yield and characteristics. Required characteristics of lubricating distillates include minimum limitation upon API. gravity (maximum specific gravity) and maximum pour-point (usually about zero Fahrenheit), as well as absence of paraffin wax.

A typical method of determining the suitability of a Gulf Coast crude oil for manufacture of low cold-test lubricants is that used by the Texas Company. A distillate of high viscosity is acid treated and then decolorized with finely-ground clay until the desired colour is obtained. The decolorized oil, freed from clay and water, is placed in a cooling chamber at a temperature of about 30° F. (-1° C.) for 3 or 4 days. If under this treatment the product remains perfectly clear, it is considered satisfactory for manufacture of lubricants free from wax.

Tabulated Analyses of Gulf Coast Petroleum.

Table I contains tabulated summaries of analyses of 132 samples of crude oils. The analyses were made at the petroleum experiment station of the United States Bureau of Mines at Bartlesville, Okla. The table is made up of 31 columns and the data applying to each analysis appear on one line. Analyses are arranged in the table in alphabetical order of the names of fields. Samples from oilfields in Duval, Starr, and Webb counties of Texas are included in Table I because these oils are not discussed in other chapters of this treatise. These counties usually are not included in the Gulf Coast district but are considered to be a part of a separate producing area designated as the south-west Texas district.

Table II contains tabulated summaries of analyses of

54 additional samples of crude oils from Texas Gulf Coast fields. The analyses were made at the petroleum experiment station of the United States Bureau of Mines at Bartlesville, Oklahoma, in the same manner as the analyses represented in Table I.

The same analyses as given in these two tables have been used by D. C. Barton (*Problems of Petroleum Geology* 1934, pp. 109-55; *Bull. Amer. Assoc. Petr. Geol.*, 21, (7) pp. 914-46) in his study of the properties of Gulf Coast petroleum in relation to their geologic source.

Refining Values of Gulf Coast Petroleum

Gulf Coast crude oils differ rather widely in those characteristics that are most frequently used as a measure or indication of comparative value. In the Humble field, for example, three distinct types of crude oil varying from Grade 'A' to low Grade 'B' oils are obtained from six different producing horizons. The gravities of Gulf Coast crude oils cover a wide range; some are heavier than 20° API, and others are lighter than 40° API. (sp. gr. 0.934 to 0.825); the viscosity of most of them at 100° F. is less than 100 sec. Saybolt Universal, and the pour-point is below 5° F. Although sulphur content of the crude oils in Table I ranges from less than 0.10 to 2.40%, approximately three-quarters of the samples had sulphur content between 0.15 and 0.45%.

The straight-run gasoline fraction of some Gulf Coast crude oils has a high octane rating, whereas the same fraction of other Gulf Coast oils has a relatively low octane rating. Kerosine can be made commercially from some Gulf Coast oils but cannot be made from others. It is surprising to note that residual cylinder stock is made commercially from some Gulf Coast crude oils. Therefore it is difficult to make even general statements concerning the properties of these oils, and examples given in this article should be considered as illustrative rather than typical or general.

The arrangement of the data in Table I to accord with the alphabetical order of the fields has been made to facilitate comparison of properties of oils from different producing horizons in the same field. The data can, of course, be arranged in other ways, for example, according to geological age of the producing formations, according to the base of the oils, and on the basis of content of total gasoline and naphtha. These and other groupings serve to emphasize various, more or less general relationships between the oils.

The wax-free oils of naphthene-intermediate base and intermediate base are an interesting group. These oils are

similar in their boiling-point-gravity-viscosity relationships to certain crude oils from the Baku and Ural-Emba districts of the U.S.S.R. (Russia). Their lubricant fractions may be characterized as naturally-occurring dewaxed intermediate-base oils. Wax-bearing intermediate-base crude oils usually show little or no 'viscous lubricating distillate' by the Bureau of Mines analysis because of the effect of the wax in reducing the viscosity at 100° F. In contrast to such wax-bearing oils, some wax-free intermediate-base oils show more than 10% of 'viscous lubricating distillate' by the Bureau of Mines method of interpretation.

Gulf Coast distillates exhibit wide variations in boiling-point-gravity-viscosity relationships. These variations are shown most strikingly by the gravity ranges of 'non-viscous' and 'medium' lubricating distillates listed in Table I. Although all the fractions listed in column 20 of Table I have a viscosity range from 50 to 100 sec. Saybolt Universal at 100° F. (see notes, Table I), the gravity of the fractions varies from a range of 23.5 to 19.8° API, for a sample from the Vinton field of Louisiana to a range of 37.2 to 30.8° API, for a sample from the Slick field of Texas. Similarly, fractions listed in column 22 have a viscosity range from 100 to 200 sec. Saybolt Universal at 100° F.; nevertheless their gravity varies from a range of 19.8 to 18.2° API, for the Vinton sample to a range of 30.8 to 27.1° API, for the sample from the Slick field. Variation in these characteristics in oils from different producing formations in the same field are illustrated by the data in columns 20 and 22 of Table I on samples from the Lockport field of Louisiana.

Gasoline

Straight-run Gasoline. Table I shows that many Gulf Coast oils have less than 10% of distillate suitable for gasoline stock, although several prolific producing formations yield oils containing 30% or more of gasoline distillate. Many of the crude oils that yield fractions within the gasoline range of boiling-points are deficient in the more volatile constituents of gasoline. Therefore straight-run gasoline from Gulf Coast crude oil usually must be blended with natural gasoline or with volatile material from other sources to provide a motor fuel that will meet market requirements. However, straight-run gasoline stock from Gulf Coast crude oils usually has a low sulphur content and this fraction from some Gulf Coast oils has a high octane rating.

An idea of the amount and characteristics of the straight-run gasoline portion of some Gulf Coast crude oils can be obtained from Table III. Data in the table are taken from

TABLE III
Properties of Gasoline Stocks from Gulf Coast Crude Oils

Field	Parish or County	State	Properties of the crude oil		% of crude		Gasoline stock				Corrosion, Cu. strip	Doctor test	Colour Saybolt	
			API.	% S.	I	II†	*API.	% S.	Octane number, A.S.T.M.	I.B.P. °F.				F.B.P. °F.
High Island	Galveston	Tex.	28.7	0.24	15.2	15.3	52.6	0.01	63	140	385	positive	negative	25
Angellia	San Patricio	"	33.9	0.18	31.0	29.3	49.7	0.04	68	167	383	20
Spindletop	Jefferson	"	27.1	0.23	8.8	11.1	49.0	0.06	69	167	382	negative	..	20
Barber's Hill	Chambers	"	26.8	0.28	8.3	7.7	49.5	0.04	66	189	362	positive	..	21
Vanderbilt	Jackson	"	32.5	0.23	24.4	21.0	51.8	0.03	65	180	360	22
Sulphur	Calcasieu	La.	24.5	0.35	7.0	7.9	48.5	0.015	70	186	364	negative	..	27

* This column gives the percentage by volume of distillate below 200° C. (392° F.), excluding fractions heavier than 40° API. (sp. gr. 0.825) calculated from the Atlantic Refining Company's laboratory report. This is 'Total gasoline and naphtha' by the Bureau of Mines method of interpretation.

† This column gives the percentage by volume of gasoline stock as stated in the oil company's laboratory report, based on the '50% point' of the distillate. Data in the table relate to this fraction.

routine laboratory evaluations made by the Atlantic Refining Company, Philadelphia, Pennsylvania, U.S.A. Some of the samples are from single wells and others are composites of deliveries over a period of time.

Laboratory examination of crude petroleum in the refinery in which these samples were analysed is made by a procedure similar to the Bureau of Mines method, using a larger charge. In the distillation at atmospheric pressure, the first fraction is taken at the lowest integral multiple of 25° C. which the vapour indicates on the thermometer and at each 25° C. interval until a thermometer reading of 250° C. is reached. Therefore, results are comparable with those obtained with the Bureau of Mines apparatus, although identical results would not be expected because of the probability of differences in degree of fractionation. The column headed 'I' in Table III shows the percentage of distillate by volume calculated from the Atlantic Refining Company's distillation report of fractions obtained below a distillation thermometer reading of 200° C. (392° F.), discarding fractions with gravity heavier than 40° API (sp. gr. 0.825). This is 'total gasoline and naphtha' according to the Bureau of Mines method of calculation.

The Atlantic Refining Company calculates the straight-run gasoline content of these crude oils to be equal to the volume of distillate of which approximately 53% distills below 284° F. by A.S.T.M. method D. 86. 'Gasoline stock' content as stated in the oil company's laboratory report is given in the column headed 'II'. Although the basis of calculation is different from that used by the Bureau of Mines in estimating 'total gasoline and naphtha' content, the data in columns headed 'I' and 'II' of Table III show that approximately the same gasoline content is indicated by both methods.

These data indicate that the figures in columns 13 and 14 of Table I approximate the content of straight-run gasoline stock in the crude oils, in so far as distillation range is concerned. However, 'total gasoline and naphtha' fractions from some of these crude oils may have such a low octane rating that all or a portion of the fraction may be more satisfactory for manufacture of kerosene than as gasoline.

Yields of Gasoline by Cracking. Not only do the Gulf Coast petroleum yields straight-run gasoline stock of good quality with high octane rating and low sulphur content, as shown in the preceding section, but they also are good material for the manufacture of gasoline by cracking.

The Universal Oil Products Company, Chicago, U.S.A., has supplied unpublished data from their files, showing results of cracking Gulf Coast oils by the Dubbs process in the laboratory pilot plant. Table IV is compiled from the laboratory reports of that company.

Summary of Gasoline Yields. These data give an approximation of the yields and characteristics of straight-run gasoline and of cracked gasoline from light and heavy Gulf Coast crude oil and gas oil. The data probably are not sufficiently comprehensive to give a complete picture of the possibilities of Gulf Coast petroleum as a source of gasoline, but they serve to show that large yields of good quality gasoline can be manufactured.

Kerosene

The question whether or not kerosene can be made commercially from Gulf Coast crude oils seems to resolve into whether distillates with the necessary characteristics are present in the crude oil in sufficient quantity, and if part of the distillate is more desirable as kerosene than as gasoline. During the years when gasoline in the United States was

made to a final boiling-point of approximately 437° F. (225° C.), little if any kerosene could be made from the remaining distillate from Gulf Coast crude oils. This probably is the basis for the statement sometimes made that

TABLE IV

Results of Cracking Gulf Coast Oils by the Dubbs Cracking Process in a Laboratory Pilot Plant

Kind of oil	Heavy Refugio crude oil	White Castle crude oil	Black Bayou crude oil	Gulf Coast gas oil
Crude oil				
API gravity	23.2	24.0	23.4	..
Sulphur, %	0.25	0.21	..
Gasoline, %	nil	4.6	9.0	..
Charging stock				
API gravity	23.2	24.0	21.2	28.5
Per cent. of crude oil	100	100	90.7	..
Cracking conditions				
Pressure, lb. per sq. in.	350	250	350	400
Temperature, ° F.	950	950	950	950
Charging rate, gal. per hr.	1.25	1.12	0.99	0.84
Finished gasoline, including straight-run				
Per cent. of crude oil	53.0	55.4	54.5	61.0
API gravity	49.8	51.0	49.8	52.8
Sulphur, %	0.04	0.03	0.05
I.B.P.-F.B.P., ° F.	97-404	111-395	122-396	97-401
Octane number (research method)				
Residuum	91	85	88	90
Per cent. of crude oil	31.7	31.6	30.6	18.3
API gravity	1.7	5.3	1.3	1.008*
Vis. S.F. at 122° F.	64	178	183	218
Gas, cu. ft. per bbl. charging stock	735	540	732	796
Gas, coke, and loss				
Per cent. of charging stock	15.3	10.6	13.4	20.7

* Specific gravity.

kerosene is not manufactured from Gulf Coast crude oils. However, with the present emphasis on low final boiling-point and high octane rating, which reduced the final boiling-point of gasoline to 400-410° F., a larger quantity of material became available for manufacture of kerosene. The statement may be made as a generality that Gulf Coast distillates with sufficiently high flash-point, that have a viscosity between 375 and 400 on the Saybolt Thermoviscometer scale, and have a gravity of 42° API or lighter, will be satisfactory for manufacture of kerosene with a light acid treatment (4-8 lb. of 66°Be. sulphuric acid per barrel) and sweetening. Such a product will have excellent burning quality.

Columns 15 and 16 of Table I indicate the probability that many Gulf Coast crude oils contain a substantial quantity of material that will fulfil these requirements and therefore are suitable for manufacture of kerosene of good quality. Probably larger portions of some crude oils than are indicated in column 15 are suitable for manufacture of kerosene of good quality, particularly from crude oils whose lighter fractions are unsatisfactory for manufacture of gasoline because of low octane rating or because greater volatility is desired.

Gas Oil

Light Gas Oil. In the Bureau of Mines approximate summary of distillation of crude petroleum, all distillate heavier than 40° API gravity (sp. gr. 0.825) and with viscosity less than 50 sec. Saybolt Universal at 100° F. is classed as gas oil. This classification is made for all crude

oils irrespective of the fact that some portion of this fraction may be suitable for manufacture of heavy naphtha or kerosine. Although an arbitrary classification of this kind is open to objection, it affords a means of comparing crude oils on the basis of significant properties and gives information regarding boiling-point-gravity-viscosity relationships that is useful in evaluating the oils.

For example, it is obvious that the gas-oil fraction from a crude oil that has an 'intermediate' key fraction No. 1 will have a lower initial boiling-point than a gas-oil fraction from a crude oil that has a paraffinic 'key fraction No. 1'. If the key fraction No. 1 is naphthenic the initial boiling-point of the gas-oil fraction may be still lower, because of the relatively low boiling-points of naphthenic fractions with gravity heavier than 40-0° API. Similarly, gas-oil fractions from crude oils that have a paraffinic 'key fraction No. 2' usually will have higher final boiling-points than gas-oil fractions from wax-free crude oils that have an intermediate or naphthenic 'key fraction No. 2', because of the effect of wax in lowering the viscosity in relation to boiling-point, thus increasing the yield of gas oil at the heavy end. However, the range of variation in final boiling-points of gas-oil fractions is not as great as the range of variation in initial boiling-points.

Estimation of gas-oil content according to the Bureau of Mines method is particularly apt when applied to Gulf Coast crude oils, as it segregates a fraction that has useful properties. This is illustrated by the data in columns 17 and 18 of Table I. In addition to the properties outlined above, naphthenic gas oils from Gulf Coast crude oils have pour-points below zero Fahrenheit and most of them contain less than 0.1% sulphur. They appear to be good material for manufacture of light domestic heating oils. Most of these gas-oil fractions appear to be excellent cracking stock for the manufacture of gasoline although some of them, because of their extremely naphthenic constitution may be rather refractory. The paraffinic gas oils are much lighter in gravity than the naphthenic gas oils, and contain only small amounts of sulphur. They apparently would be excellent Diesel-engine fuels, as their gravity-boiling-point relationships indicate that they would have good ignition quality. They appear to be excellent cracking stock for the manufacture of gasoline and also for making artificial gas.

Heavy Gas Oil. In addition to the light gas oil discussed in the preceding paragraphs, Gulf Coast crude oils may yield variable quantities of heavier gas oil depending upon the characteristics of the crude oil and upon operating conditions in the refinery. These heavier gas oils may be unsatisfactory for manufacture of lubricants either because of low flash-point or high pour-point. Most of them are suitable for cracking stock, although some heavy gas oils are so naphthenic that they may be refractory under cracking conditions. They appear to meet the requirements for heavy distillate fuel oil. These heavy gas oils, containing no constituents with viscosity less than 50 sec. Saybolt Universal at 100° F. in most instances contain less than 0.5% sulphur, and the sulphur content of many of them is less than 0.4%.

Lubricants

Distillate Lubricants. The value of Gulf Coast crude oils as raw material for manufacture of lubricants has been affected materially by changes during recent years in refinery practice and in market requirements. Until comparatively recently, wax-free petroleum was the only source of viscous lubricants with low pour-points. Among wax-free oils,

those from the Gulf Coast had the advantage of low sulphur and asphalt content. However, with the development about 1927 of commercial processes for more complete dewaxing of lubricating oils, crude oils containing substantial quantities of paraffin wax became available for manufacture of low pour-point lubricants. Recent improvements in equipment for continuous distillation and fractionation under vacuum have aided refiners of Gulf Coast oils by reducing costs and enabling them to produce lubricating distillates that contain still less asphaltic material and are less decomposed at distillation temperatures than was the case with older equipment. These distillates can be manufactured into finished lubricating oils with less treatment and smaller treating losses than formerly.

Heat Engineering, vol. 5, no. 3, March 1930, published by Foster Wheeler Corporation, New York, gives a brief description, with photographs and a flow diagram, of a 5,000-barrel rated capacity atmospheric and vacuum distillation unit operating on Coastal crude oil. Yields and characteristics of products obtained during operation of the unit are given as follows:

Kerosine:		Yield 7-2%
Gravity, API	36°	
F.B.P.	446° F.	
Gas Oil:		Yield 23-6%
Gravity, API	29-2°	
I.B.P.	448° F.	
F.B.P.	596° F.	
Lubricating distillate 'A'		Yield 16-5%
Gravity, API	26-4°	
Vis., S.U. at 100° F	58	
Flash	285° F.	
Fire	310° F.	
V-G.C.	0-870	
Lubricating distillate 'D'		Yield 10-5%
Gravity, API	23-4°	
Vis., S.U. at 100° F	90	
Flash	325° F.	
Fire	370° F.	
V-G.C.	0-880	
Lubricating distillate 'B'		Yield 23-7%
Gravity, API	19-7°	
Pour-point	5° F.	
Vis., S.U. at 210° F	68	
Flash	405° F.	
Fire	495° F.	
V-G.C.	0-877	
Lubricating distillate 'C'		Yield 6-7%
Gravity, API	18-9°	
Pour-point	35° F.	
Vis., S.U. at 210° F	176	
Flash	525° F.	
Fire	610° F.	
V-G.C.	0-866	
Tar		Yield 11-8%
Melting-point	100° F.	
Flash	620° F.	
Fire	720° F.	

The 'viscosity-gravity constant' has been proposed by Hill and Coats [5, 1928] to indicate the degree of the paraffinic or naphthenic character of viscous fractions of petroleum. Viscosity-gravity constants (V-G.C.) according to the formulas of Hill and Coats have been calculated from the gravities and viscosities of the distillates. The variation in the viscosity-gravity constant of successive fractions is not unusual for Gulf Coast crude oils.

These data indicate in a general way the quantities and some of the characteristics of distillates that may be obtained from wax-free Gulf Coast crude oils that do not contain a gasoline fraction.

Laboratory Determinations. The data in columns 19 to 28 of Table I indicate the percentage yields and gravity ranges of lubricating distillates obtained by the Bureau of Mines method in laboratory distillations of Gulf Coast crude oils to a vapour temperature of 300° C. (572° F.) at an absolute pressure of 40 mm. of mercury, and the percentage, gravity, and Conradson carbon residue of the residuum remaining in the distilling flask. These data indicate the differences in gravity ranges for the same viscosity ranges and further emphasize the wide variations in physical properties encountered among the oils produced in this district.

Table V, compiled from the Atlantic Refining Company's reports of laboratory crude-oil distillations mentioned previously gives more complete data on lubricating distillates of the crude oils. Differences in viscosity-gravity constants (V-G.C.) shown in the table for the untreated and treated viscosity distillates are examples of the small change in this value that accompanies loss in volume of 10 to 15% of lubricating distillates as a result of conventional treatment with sulphuric acid.

TABLE V

Laboratory Determinations of Lubricating Distillate Content

	% of crude	Gravity, °API	Visc. S.U. at 100° F.	V-G.C.	Open cup		Pour-point, °F.
					Flash °F.	Fire °F.	
Spindletop, Texas:							
Non-viscous distillate	5.4	25.5	52	0.879	270	305	-40
Medium distillate	16.1	23.3	115	0.877	325	375	-15
Viscous distillate	12.5	20.7	609	0.874	415	470	20
Same, treated with H ₂ SO ₄	11.2	21.3	525	0.871	415	475	20
Barber's Hill, Texas:							
Non-viscous distillate	8.7	27.0	52	0.869	285	320	-60
Viscous distillate	31.7	21.9	615	0.864	440	490	-15
Same, treated with H ₂ SO ₄	27.2	22.3	590	0.861	430	485	-15
Sulphur, Louisiana:							
Non-viscous distillate	7.2	26.5	53	0.872	285	310	-60
Medium distillate	14.4	23.6	115	0.874	350	380	-35
Viscous distillate	28.6	20.8	594	0.874	415	470	-10
Same, treated with H ₂ SO ₄	24.3	21.4	530	0.870	410	470	-5

TABLE VI

Laboratory Determinations of Black Oil Content

Kind of oil	Spindletop		Barber's Hill		Heavy Refugio
	Per cent. of crude	Gravity, °API	Per cent. of crude	Gravity, °API	Per cent. of crude
Per cent. of crude	12.4	17.8	33.1	24.1	22.4
Gravity, °API	17.8	15.2	19.1	17.9	13.5
Vis. S.U. at 210° F.	277	152	291	163	163
Vis. Engler at 100° C.	7-43
Flash, P-M., °F.	460	450	510	415	415
Flash, open cup, °F.	535	475	535	490	490
Fire, open cup, °F.	610	540	615	500	500
Pour-point, °F.	45	30	35	30	30
Holdes hard asphalt, %	0.064	..	0.11	0.06	0.06

Black Oil Stocks. Possible yields and characteristics of black oils from Gulf Coast crude oils are shown in Table VI compiled from the Atlantic Refining Company's reports of laboratory examination of the crude oils.

Solvent Refining. Refining of lubricating oils by means of selective solvents is a recent development in petroleum technology that appears likely to have far-reaching influence on yields and characteristics of products, and also on comparative value of crude oils. Various solvent-refining processes are described in other portions of this treatise and they are not discussed in detail in this article.

The various processes may be summarized by the statement that the reason for using selective solvents in refining petroleum lubricating stocks is to separate the desirable components from the undesirable components. The process does not create, but merely segregates whatever might be in the stock. Therefore the economics depend upon the amount of material in the stock to be processed and the efficiency with which the solvent removes the undesirable material.

The selectivity of different solvents varies, some having the ability to remove more of the undesirable component than others. As the extraction process is based fundamentally upon the relative solubilities of the desirable and undesirable constituents, the effects of temperature and amount of solvent used are the controlling factors. The optimum conditions can be determined for each stock by laboratory work, and in general can be ascertained by establishing a typical phase diagram for a three-component system.

Table VII illustrates the variation in yield of desirable product that can be obtained from various crude sources, using nitrobenzene as a selective solvent. These yields represent lubricating oil of substantially the same quality as measured by the Viscosity-Gravity Constant (V-G.C.) of Hill and Coats [5, 1928] and will have viscosity indexes of approximately 100.

TABLE VII

Yields of Desirable Product by Nitrobenzene Extraction

Crude source of lubricating stock	V-G.C. of stock	Yields of 0-810 V-G.C. material, per cent.
Winkler	0.880	27
Spindletop	0.875	31
Barber's Hill	0.870	34
West Texas	0.860	43
Seminole	0.842	58
Pennsylvania	0.814	92

Authority: T. G. Delbridge, Atlantic Refining Co., in a communication to the author.

The value of selective solvents in increasing the viscosity index and otherwise improving the quality of lubricating oils from Gulf Coast crude oils is shown by the following data.

R. K. Stratford, O. S. Pokorny, and J. L. Huggett [10, 1933] give the following example of 'before and after' treatment of a Gulf Coast distillate extracted with phenol:

TABLE VIII

Results of Extraction of a Gulf Coast Distillate with Phenol

	Before	After
Vis. S.U. at 210° F.	64	60
Gravity, °API	20	25.8
Viscosity index	22	74
Viscosity-Gravity constant	0.877*	0.829*
Conradson carbon residue	0.125	0.029
Pour-point, solid at, °F.	-10/-15	0/-5
Colour, Tag-Robinson	blue, opaque	9½
Yield, per cent.	..	64.7

* Viscosity-gravity constants have been calculated according to the formula of Hill and Coats [5, 1928] from the gravities and viscosities.

S. W. Ferris, W. A. Myers, and A. G. Peterkin [3, 1933] give the following data on the use of nitrobenzene as a selective solvent for lubricant portions of Gulf Coast crude oils:

engineers of the United States Bureau of Mines from oil fields of the Gulf Coast district in the States of Louisiana and Texas, and analysed at the Petroleum Experiment

TABLE IX
Results of Extraction of Gulf Coast Lubricating Stocks with Nitrobenzene

Description	Treatment			Properties				
	% nitrobenzene	Temperature, °F.	Nitroaffin yield*	Stock	Viscosity at 100° F.	Viscosity at 210° F.	Gravity, °API.	Viscosity-Gravity Constant
Barber's Hill distillate	Stock	..	136	20.2	0.859
	130	50, 59, 68	54.0	Nitroaffin	..	98	26.1	0.819
	130	59, 68, 77	46.0	96	27.0	0.813
Barber's Hill distillate	Stock	..	73	21.1	0.864
	125	50	49.9	Nitroaffin	..	59	27.9	0.818
	Stock	..	419	16.3	0.874
Barber's Hill residuum	Nitroaffin	..	186	24.6	0.818
	150	59, 77, 95	40.0	Stock	..	612	20.6	0.874
	Nitroaffin	..	319	30.3	0.810
Coastal distillate	315	31.5	0.801
	100	50	27.9	Stock	..	454	16.0	0.876
	150	50	21.6	Nitroaffin	..	196	24.4	0.819
Barber's Hill residuum	Stock	..	305	17.5	0.869
	150	50, 86, 113	38.3	Nitroaffin	..	149	25.5	0.816
	141	26.3	0.810
Barber's Hill distillate	Stock	..	420	16.5	0.872
	120	68, 77, 86	42.0	Nitroaffin	..	151	26.3	0.809
	150	68, 77, 86	41.5	434	22.4	0.865
Barber's Hill distillate	Stock	..	257	29.6	0.818
	160	77, 95, 122	31.3	Nitroaffin
	150	41, 59, 77	43.7

* Per cent. of stock by volume. This column shows the yield of desirable material with the properties shown in the table under 'Properties.'

Discussion of manufacturing costs and other items involved in the economics of solvent extraction is beyond the scope of this article, which deals with the properties of Gulf Coast oils and their products. Whether or not production of lubricating oils with high viscosity-index from Gulf Coast crude oils is economically feasible probably will not be determined until solvent refining processes have had a longer history. The tendency at present seems to be to use as a starting material for solvent extraction oils with as good characteristics as possible, and to improve those characteristics. Attention has been directed in this article to the fact that the viscous portions of some Gulf Coast crude oils have desirable viscosity-gravity relationships together with low pour-point. Such oils appear to be well suited to refining by solvent extraction.

As has been pointed out by R. E. Wilson and P. C. Keith, Jr. [14, 1934].

'Yield is of secondary importance. In general more crude is run than is processed to lubricating oils and therefore the lubricating oil yield from the solvent processes is important only in so far as it affects plant cost and operating cost. Raw material is essentially worth only fuel oil or cracking stock prices.'

In this connexion, the United States Bureau of Mines reports that yield of lubricants in 1934 in the refineries in the Texas Gulf Coast district was 3.1% of crude oil run to stills. This figure is not an accurate representation of the yield of lubricants from Gulf Coast crude oils, as these refineries processed oils from other fields of Texas and from other States, as well as imported petroleum. However, it is evident that a great deal more lubricating oil could have been made from the crude oil run to stills in this district than was actually the case.

Summary and Conclusions

This article presents summarized results in tabular form of analyses of samples of crude petroleum obtained by

Station of the Bureau of Mines at Bartlesville, Oklahoma. Laboratory reports of analyses of crude oils supplied through the courtesy of the Atlantic Refining Company, Philadelphia, and unpublished reports supplied by the Universal Oil Products Company, Chicago, on cracking tests in a laboratory pilot plant have been used to derive information to supplement data obtainable from the bureau's analyses. Data from the literature on characteristics of Gulf Coast crude oils are used to show yields and properties of products that may be obtained by continuous distillation under reduced pressure and by extraction of lubricant fractions with selective solvents. Possible yields and characteristics of kerosine, gas oil, and black oil are indicated.

Gulf Coast crude oils usually are considered to be naphthene-base oils, and are often referred to as asphalt-base oils. Data presented in this article indicate that both of these opinions are inaccurate as to many of the oils. Although most of the oils are classed as naphthene base, intermediate characteristics are ascribed to many of them, and a few have paraffinic characteristics, aside from the presence of paraffin wax. The low carbon residue of residuum of many of the oils indicates that they contain little asphalt. This is indicated also by the colour, which is green or brown rather than black, and by the low sulphur content, which appears to be incompatible with presence of more than small proportions of asphalt.

Data in this article show that it is difficult to make statements applicable to all the oils produced in the Gulf Coast district, regarding the properties of the oils. Certain crude oils are decidedly paraffinic in the lighter portions while being naphthenic in the heavier part, and others are naphthenic in the lower-boiling portion and decidedly paraffinic in the heavier portion. Practical experience in processing the oils has shown that because of the differences in physical and chemical properties the oil from each field and each stratum is a separate problem in commercial utilization.

Subject to the limitations just mentioned the data indicate that the straight-run gasoline stock obtainable from Gulf Coast crude oils has good octane rating and low sulphur content. Large yields of gasoline of good quality also can be obtained by cracking the crude oil or fractions thereof.

The analyses indicate the possibility of obtaining large yields of kerosine with desirable characteristics from some Gulf Coast oils with comparatively little treatment.

The straight-run gas oil fractions from various Gulf Coast crude oils range in properties from those typical of highly naphthenic types to typical intermediate oils. However, almost all of them contain only small amounts of sulphur, which is unusual for naphthenic gas oils. Apparently the gas-oil fraction from some Gulf Coast crude oils would be good Diesel-engine fuel, whereas the gas oil distilled from other Gulf Coast oils, in some

instances from the same field, appears to be unsatisfactory as Diesel-engine fuel because of the naphthenic characteristics, which indicate poor ignition quality. Straight-run gas oils from Gulf Coast crude oils apparently would be good fuel for domestic heating because of low pour-point and low carbon-residue content.

Almost all Gulf Coast straight-run gas oil is satisfactory for cracking to make gasoline, although some gas oils are so naphthenic that they probably are refractory.

Lubricants from Gulf Coast crude oils usually are distillates, although residual cylinder stocks are made from some Gulf Coast crude oils and residues from other oils are satisfactory for use as black oils. Distilled lubricants can be refined either by conventional processes, using sulphuric acid and caustic soda, or by the new methods employing selective solvents, or by a combination of the processes.

REFERENCES

1. CRAFT, B. C. *Trans. Amer. Inst. Min. Met. Eng.* 123, 389 (1937).
2. DEAN, E. W., and others. *U.S. Bur. Mines Bull.* 207 (1922).
3. FERRIS, S. W., MEYERS, W. A., and PETERKIN, A. G. *Refiner*, 12, 435 (1933).
4. FOSTER-WHEELER CORP. *Heat Engineering*, 5, no. 3 (1930).
5. HILL, J. B., and COATS, H. B. *Ind. Eng. Chem.* 20, 641 (1928).
6. KRAEMER, A. J., and GARTON, E. L. *U.S. Bur. Mines Rept. Investigations* 3253 (1934).
7. KRAEMER, A. J., and GRANDONE, PETER. *U.S. Bur. Mines Rept. Investigations* 2808 (1927).
8. SMITH, N. A. C. *U.S. Bur. Mines Rept. Investigations* 2806 (1927).
9. SMITH, N. A. C., and LANE, E. C. *U.S. Bur. Mines Bull.* 291 (1928).
10. STRATFORD, R. K., POKORNY, O. S., and HUGGETT, J. L. *Refiner*, 12, 458 (1933).
11. TAYLOR, SAM S., and SMITH, H. M. *U.S. Bur. Mines Rept. Investigations* 3238 (1934).
12. VIETH, W. V., and Hayes, E. P. *Trans. Amer. Inst. Min. Met. Eng.* 123 472 (1937).
13. WADE, GUSTAV. *U.S. Bur. Mines Rept. Investigations* 3252 (1934).
14. WILSON, R. E., and KEITH, P. C. Jr. *Oil and Gas J.* 33, (9), 14 (1934).

CANADA

By G. EGLOFF, M.A., Ph.D.
Universal Oil Products Company

THERE are seven productive crude oilfields in Canada, Calgary, Petrolia, Oil Springs, Bothwell, Mosa, Fort Norman, and Stony Creek. The depth of the oil-bearing strata is from 365 ft. to 2,765 ft.; API gravities of the crude range from 33.2 to 54.2 with gasoline and naphtha contents from 19.4% to 90.1%, and sulphur content varying from 1.05 to 0.11%. There are 35 refineries in Canada with a daily capacity of 178,375 bbl. and cracking installations of 66,700 daily. The analysis of the crude is shown in Tables I-IV.

TABLE I

Canadian (Fort Norman Field, Mackenzie River, Northwest Territories) Crude Oils

Gravity, °API	35.8
Sp. gr. at 60° F.	0.846
Sulphur, %	0.33
Pour-point, ° F.	below 5
Water, %	nil
Viscosity (Saybolt-Universal), sec. at 70° F.	48
Viscosity (Saybolt-Universal), sec. at 100° F.	41
Colour	dark green

Hempel Distillation (air)

Temperature, ° F.	% cut	Sum %	Sp. gr. cut	°API cut	Viscosity	Cloud test, °F.
Up to 122	0.6	0.6	0.672	79.1
122-167	2.2	2.8
167-212	5.1	7.9	0.709	68.1
212-257	7.1	15.0	0.735	61.0
257-302	6.9	21.9	0.756	55.7
302-347	6.0	27.9	0.776	50.9
347-392	5.5	33.4	0.795	46.5
392-437	5.8	39.2	0.810	43.2
437-482	5.8	45.0	0.825	40.0
482-527	6.0	51.0	0.838	37.4

Hempel Distillation (vacuum)

Temperature, ° F.	% cut	Sp. gr.	°API	Viscosity	Cloud test, °F.
Up to 392	5.2	0.859	33.2	43	below 5
392-437	5.8	0.870	31.1	49	30
437-482	5.1	0.881	29.1	67	50
482-527	4.9	0.889	27.7	109	66
527-572	5.9	0.907	24.5	230	82

Carbon residue of residuum, 2.8%.

	%	Sp. gr.	°API	Viscosity
Light gasoline (up to 212° F.)	7.9	0.696	71.8	..
Total gasoline and naphtha	33.4	0.747	57.9	..
Kerosine distillate	11.6	0.817	41.7	..
Gas oil	14.5	0.851	34.8	..
Non-viscous lubricating distillate	9.0	0.870-0.887	31.1-28.0	50-100
Medium lubricating distillate	5.2	0.887-0.903	28.0-25.2	100-200
Viscous lubricating distillate	4.2	0.903-0.917	25.2-22.8	above 200
Residuum	21.3	0.964	15.3	..
Distillation loss	0.8

TABLE II

Canadian (Stony Creek Field, New Brunswick) Crude Oils

Gravity, °API	37.2
Sp. gr. at 60° F.	0.839
Sulphur, %	0.10
Pour-point, ° F.	20
Water, %	nil
Viscosity (Saybolt-Universal), sec. at 70° F.	120
Viscosity (Saybolt-Universal), sec. at 100° F.	90
Colour	green

Hempel Distillation (air)

Temperature, ° F.	% cut	Sum %	Sp. gr. cut	°API cut	Viscosity	Cloud test, °F.
Up to 122	1.8	1.8	0.660	82.9
122-167	1.3	3.1	0.675	78.1
167-212	2.3	5.4	0.704	69.5
212-257	3.3	8.7	0.728	62.9
257-302	3.5	12.2	0.748	57.7
302-347	3.5	15.7	0.762	54.2
347-392	3.1	18.8	0.778	50.4
392-437	3.6	22.4	0.790	47.6
437-482	4.0	26.4	0.802	44.9
482-527	4.5	30.9	0.812	42.8

Hempel Distillation (vacuum)

Temperature, ° F.	% cut	Sp. gr.	°API	Viscosity	Cloud test, °F.
Up to 392	2.4	0.820	41.1	38	32
392-437	5.1	0.834	40.2	43	54
437-482	5.4	0.831	38.8	50	71
482-527	4.5	0.841	36.8	64	90
527-572	6.8	0.853	34.4	92	96

Carbon residue of residuum, 3.2%.

	%	Sp. gr.	°API	Viscosity
Light gasoline (up to 212° F.)	5.4	0.683	75.7	..
Total gasoline and naphtha	18.8	0.734	61.3	..
Kerosine distillate	12.1	0.802	44.9	..
Gas oil	10.2	0.825	40.0	..
Non-viscous lubricating distillate	12.2	0.831-0.856	38.8-33.8	50-100
Medium lubricating distillate	1.7	0.856-0.860	33.8-33.0	100-200

TABLE III

Canadian (Calgary Field, Alberta) Crude Oils

Gravity, °API	54.2
Sp. gr. at 60° F.	0.762
Sulphur, %	0.13
Pour-point, ° F.	below 5
Water, %	nil
Viscosity (Saybolt-Universal), sec. at 70° F.	30
Viscosity (Saybolt-Universal), sec. at 100° F.	29
Colour, N.P.A.	No. 2

TABLE III (cont.)

Hempel Distillation (air)

Temperature, ° F.	% cut	Sum %	Sp. gr. cut	°API. cut	Viscosity	Cloud test, °F.
Up to 122	1.2	1.2	0.693	72.7
122-167	3.1	4.3
167-212	8.1	12.4	0.717	65.9
212-257	25.4	37.8	0.742	59.2
257-302	26.3	64.1	0.762	54.2
302-347	18.5	82.6	0.776	50.9
347-392	7.5	90.1	0.791	47.4
392-437	4.0	94.1	0.804	44.5

	%	Sp. gr.	°API.
Light gasoline (up to 212° F.)	12.4	0.709	68.1
Total gasoline and naphtha	90.1	0.754	56.2
Kerosine distillate	4.0	0.804	44.5
Residuum	5.6	0.866	31.9
Distillation loss	0.3

TABLE IV

Canadian (Petrolia Field, Ontario) Crude Oils

Gravity, °API.	33.2
Sp. gr. at 60° F.	0.859
Sulphur, %	0.92
Pour-point, ° F.	below 5
Water, %	nil
Viscosity (Saybolt-Universal), sec. at 70° F.	100
Viscosity (Saybolt-Universal), sec. at 100° F.	68
Colour	dark green

TABLE IV (cont.)

Hempel Distillation (air)

Temperature, ° F.	% cut	Sum %	Sp. gr. cut	°API. cut	Viscosity	Cloud test, °F.
Up to 122
122-167	1.6	1.6	0.696	71.8
167-212	2.4	4.0	0.710	67.8
212-257	4.3	8.3	0.732	61.8
257-302	4.6	12.9	0.753	56.4
302-347	4.9	17.8	0.773	51.6
347-392	4.4	22.2	0.787	48.3
392-437	4.8	27.0	0.799	45.6
437-482	5.0	32.0	0.810	43.2
482-527	6.3	38.3	0.824	40.2

Hempel Distillation (vacuum)						
Temperature, ° F.	% cut	Sum %	Sp. gr. cut	°API. cut	Viscosity	Cloud test, °F.
Up to 392	3.3	3.3	0.842	36.6	41	24
392-437	5.9	9.2	0.852	34.6	47	42
437-482	5.6	14.8	0.859	33.2	57	60
482-527	5.0	19.8	0.866	31.9	76	76
527-572	6.8	26.6	0.885	28.4	116	82

Carbon residue of residuum, 6.4%.

	%	Sp. gr.	°API.	Viscosity
Light gasoline (up to 212° F.)	4.0	0.704	69.5	..
Total gasoline and naphtha	22.2	0.751	56.9	..
Kerosine distillate	16.1	0.812	42.8	..
Gas oil	7.5	0.846	35.8	..
Non-viscous lubricating distillate	13.4	0.854-0.877	34.2-29.9	50-100
Medium lubricating distillate	5.7	0.877-0.896	29.9-26.4	100-200
Residuum	34.9	0.929	20.8	..
Distillation loss	0.2

MEXICO

By J. McCONNELL SANDERS, F.I.C., F.C.S., M.Inst.P.T.

Chief Chemist and Technical Adviser, The Mexican Eagle Oil Company

Historical

THE early history of oil production in Mexico is very similar to that of other oil-producing countries, in that it undoubtedly commenced with the utilization, by the natives, of the natural seepages which abound in the oil regions for their arts, industries, and religious ceremonies. These seepages are still known by the native name of 'chapopoteras', and the product derived from them, whether a semi-liquid bitumen or a hard pitch-like material, is called 'chapopote'.

The derivation of this word is usually ascribed to the Aztec *tzauc* or *tzacutli* (cement) and *popochitli* (perfume) [2, 1906], and the material is presumed to have been used by the ancient inhabitants of the country as mortar for their buildings, as a waterproofing coating for pottery ware, as an illuminant for torches, and mixed with or instead of copal resin as an ingredient of ceremonial incense.

Previous to the year 1868 interest in this important product of the country was confined to its surface indications, and bituminous deposits were treated as minerals and exploited under the mining laws, some of the harder varieties being considered as coal. In 1869 the first drilling operations were carried out by the Gulf Exploration Company, which was formed in Mexico City to exploit the discovery of oil springs in the district of Cougas, now known as Furber. This discovery was made by Dr. Antrey in 1868, and a well was drilled to a depth of 125 ft. without result. A tunnel was driven into a hill near to one of the seepages, from which about 5 bbl. per day of oil were extracted. The operations of this pioneer oil company were abandoned, but about 10 years later the property was again worked by Dr. Antrey who had the oil transported by mules to the town of Papantla, where a small still was set up, and about 95 bbl. of oil a day refined for sale in the locality. This small installation operating in 1879 can claim to be the first Mexican refinery.

In 1882 a well was drilled at Guadalupe, near Mexico City, without result, and in the same year a company organized in Boston, U.S.A., drilled two shallow wells (375-400 ft.) in Cerro Capotal, about 2 miles south of the famous Potrero del Llano field. Only a few barrels of oil were obtained and the wells were abandoned.

In 1883 a well was drilled by Governor Sarlat in the State of Tabasco, close to San Fernando in the district of Macuspansa, but without commercial results. The property was eventually taken over by the Pearson interests in 1906.

Commercial production of oil in Mexico may be said to have commenced in 1901, when the Mexican Petroleum Company of California, organized by Messrs. Dohney and Canfield, commenced drilling in their properties at Ebano in the State of San Luis Potosi. Their first well, at a depth of about 425 ft., produced 18,000 bbl. in that year, and this was increased to about 40,000 bbl. in the next year.

These results were sufficiently encouraging to attract foreign capital for further exploitation, and the development of the country's oil resources advanced with rapid strides, stimulated by the helpful attitude of the then

Mexican Government under President Porfirio Diaz, who was wise enough to realize the advantages to his country of encouraging the influx of outside capital for the financial support of the new industry.

In the year 1904 the first producing well in the Furber field was brought in, and in the same year the Pearson interests brought in their first producer in the San Cristobal field on the Isthmus of Tehuantepec.

The same interests drilled their discovery well in the San Diego field in 1908, which year is remarkable for the loss by fire of what was probably the world's largest producing well—San Diego No. 3 or 'Dos Bocas'. This well became uncontrollable and caught fire, burning for nearly 2 months until extinguished by encroaching salt-water.

The year 1910 is remarkable for a number of important 'discoveries' in the Tanhujo, Potrero del Llano, Casiano, and Panuco fields. The famous gushers, Casiano No. 7 and Potrero del Llano No. 4, probably hold the world's record as producers.

In this year also oil was pumped from the Furber fields to the sea-loading lines at Tuxpan Bar, from whence it was transported by tanker to a refinery at Minatitlan.

The subsequent history of oil production in Mexico is remarkable for the phenomenal rise in productivity, which reached a maximum in 1921, when the total production was 193,397,537 bbl., elevating Mexico to second place in order of world production. From that year until 1932 there was a steady decline to 32,805,477 bbl., Mexico taking seventh place in world productivity.

Since then the productivity curve has taken an upward turn, and at the end of 1934 the total figure was 38,048,594 bbl.

At the present time Mexico has 31 producing fields, of which only 27 can be classed as major producers. The approximate location of these is shown on the accompanying map, each field being designated by a number within a circle. The names of the respective fields corresponding to the number is shown in Table I, which also summarizes other data of interest. The column headed 'Discovery date' refers to the year in which a well with commercial production was first brought in on the field referred to: it does not signify the year in which oil was first known to exist in that field.

It is usual to classify the Mexican oilfields under three main divisions, viz.

- (a) Tampico—Tuxpan Northern Section (Fields 1 to 8 on the map).
- (b) Tampico—Tuxpan Southern Section (Fields 9 to 24).
- (c) Southern or Isthmus Section (Fields 25 to 31).

The fields numbered 10 to 17 inclusive, which contained the most prolific wells during the period of maximum productivity, are often alluded to as constituting the 'Golden Lane'.

Included in the map, and indicated by letters within triangles, are some commercially unproductive fields or wells. These are interesting, either on account of the unusual character of the oil obtained from them, or

because of their association with the earlier history of the industry.

Further information relating to these fields is summarized in Table II.

Odour. Oils from the Tampico-Tuxpan Northern Section possess a disagreeable sulphurous odour, which is also characteristic of the majority of oils from the Southern Section, with the exception of those from Poza Rica, Meca-

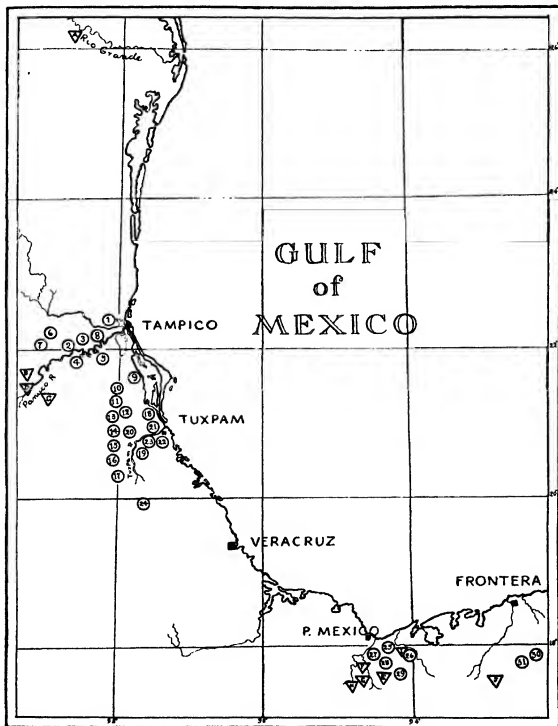

The oilfields of Mexico.

Physical Characters of Mexican Crude Oils

Colour. The majority are dark brown or black, with little or no fluorescence. Exceptional oils are those from the Isthmus fields, Tecuanapa, Sarlat, and Belem, which have an amber or dark red colour with a pronounced green bloom. The Filisola oil is reddish brown with a slight bronze sheen, while the fields of Huitzalté, San Pedro, and La Labor have yielded almost white oils with a strong blue-green fluorescence.

tepec, and Furbero, which are similar to the Isthmus oils from Tonalá, El Burro, Teapa, and El Plan, having pleasant and somewhat aromatic odours.

Specific Gravity. The range of specific gravities covered by the producing fields is summarized in Table III. Oils from the Northern Section (Map nos. 1-8) are characterized as 'heavy' with specific gravities usually greater than 0.950. The average specific gravity of oils from other fields tends to become progressively lower as one proceeds in a

NATURE OF CRUDE PETROLEUM

TABLE I

No.	Pool or field. Producing in 1934	Municipality	State	Discovery date	Producing formation	Total production, bbl.	Production 1934, bbl.	No. of producing wells, 1934	Average depth sub-sea, ft.	
1	Altamira	Chapopote	Tamaulipas	1926	CRETACEOUS LIMESTONE	2,691,639	197,705	9	1,885	
2	Cacalilao	Panuco	Veracruz	1924		232,904,712	4,126,670	166	1,662	
3	Corcovado	"	"	1925		14,873,045	962,185	54	1,939	
4	Panuco	"	"	1910		298,344,617	2,742,110	165	1,852	
5	Topila	Pueblo Viejo	"	1909		27,628,267	345,140	55	2,713	
6	Ebano	Tulillo	S. L. Potosi	1901		115,820,075	2,919,664	135	1,848	
7	Chapacao	"	"	"		"	"	"	"	
7	Limon	Valles	"	1922		4,471,584	277,895	38	2,191	
8	Caracol	Panuco	Veracruz	1912		9,139,927	323,444	39	..	
9	San Diego	Tamalin	"	1908		8,405,093	170,137	14	..	
10	Chiconcillo	Tepetate	"	1915		139,501,148	514,091	15	..	
11	N. Chinampa	Tantima	"	1913		194,471,042	1,341,556	36	1,644	
12	S. Chinampa	Amatlan	"	1913		90,473,627	1,582,923	43	..	
13	N. Amatlan	"	"	1920		13,998,406	144,473	9	1,755	
14	S. Amatlan	Tancoco	"	1920		277,125,074	3,646,073	43	1,300	
14	Zacamixtle	Tepetzintla	"	1916		"	"	"	"	
15	Totec	"	"	1916		"	"	"	"	
15	Cerro Azul	Temapache	"	1912		7,299,555	176,999	3	..	
16	Alazan	"	"	1910		103,025,144	723,911	11	1,719	
17	Potrero del	"	"	"		"	"	"	"	
17	Liano	"	"	1902		15,656,317	553,675	11	1,822	
18	Cerro Viejo	"	"	1914		77,956,408	3,069,417	27	..	
18	Tierra Blanca	Tuxpan	"	1914		"	"	"	"	
18	Chapopote	"	"	"		"	"	"	"	
19	Alamo	Temapache	"	1913		58,859,736	757,123	46	..	
19	San Isidro	"	"	"		"	"	"	"	
20	Tierra	"	"	1911		854,861	40,683	8	..	
21	Amarilla	"	"	"		"	"	"	"	
21	Tanhuijo	Tamiahua	"	1910		Oligocene	466,365	11,873	8	375
22	Coatzintla	Coatzintla	"	1930		Cretaceous Limestone	4,705,108	3,707,594	6	2,280
23	Mecatepec	"	"	1928	Upper Eocene	731,236	38,838	3	3,688	
24	Furbero	"	"	1907	Eocene	2,183,520	68,905	9	1,730	
25	El Burro	Puerto	"	1928	Middle Lower Miocene	35,433,643	3,530,202	122	2,379	
26	Tonala	Mexico	"	"	"	"	"	"		
26	El Plan	Minatitlan	"	1931	Upper Lower Miocene	8,407,023	4,193,889	24	2,462	
27	New Teapa	Puerto	"	1929	Lower Miocene	32,181	69	7	603	
28	Filisola	Mexico	"	1923	"	15,506,410	847,547	51	2,902	
29	Tecusanapa	Minatitlan	"	1911	"	71,053	127	3	341	
30	Sarlat	Macuspana	Tabasco	1891	Dolomite over salt	6,114	16	1	..	
31	Belem	"	"	1926	Upper Miocene	5,716	6	0	..	

TABLE II
Commercially Unproductive Fields

Map reference	Pool or field	Municipality	State	Discovery date	Producing formation	Depth sub-sea, ft.	Remarks
A	Camargo	Camargo	Tamaulipas	1927	Cretaceous Limestone	3,605*	Produced a very small quantity of light-coloured oil quite unlike other oils in the district.
B	Huitzalte	Valles	San Luis Potosi	1918	"	3,833	These 3 fields produced small quantities of very light-coloured oil with a blue-green fluorescence, rich in wax and unlike other oils from the neighbouring districts.
C	San Pedro	"	"	1912	"	3,656	
D	La Labor	"	"	1913	"	3,700	
E	Concepcion	Minatitlan	Vera Cruz	1909	Dolomite over salt	160	At one time commercially productive, yielding oil similar to Filisola.
F	Soledad	"	"	1910	"	555	Produced considerable amounts of oil at one time. The oil was light coloured and fluorescent, somewhat high in sulphur, low in sp. gr., contains wax and asphalt.
G	Capoacan	"	"	1905	"	376*	
H	San Cristobal	"	"	1905	"	314*	
I	Ixhuatlan	Ixhuatlan	"	1911	Hard blue marl and shale	888	Also a productive field at one time, the oil being similar to that from Tonala and Teapa.
J	Caimba	Pichucalco	Chiapas	1909	Soft grey shale	699-6	Not commercially productive field. Oil brown in colour, very little wax. Unlike oil from Sarlat and Belem fields.

* Total depth.

southward direction. In Table III are also included the expansion coefficients and viscosity ranges corresponding to the three main field divisions.

As regards viscosity, it is noteworthy that the heavier crudes, as well as fuel oils compounded from their asphaltic residual tars, exhibit a hysteresis phenomenon when stored undisturbed at low temperatures.

from the Furbero, Teapa, Tonalá, Concepcion, and Ixhuatlán fields, the reading obtained amounting to 0.2° as a maximum.

Oil from Sarlat is exceptional in showing dextro-rotatory activity amounting to 2.0° in the fractions boiling between 30 and 70° under high vacuum conditions.

The refractivity of the light fractions obtained from

TABLE III
Physical Characters, Producing Fields

Section and fields	Specific Gravity 60/60° F.			Expansion coefficient 60/60° F.			Viscosity Redwood no. 1 at 100° F., sec.		
	Max.	Min.	Mean	Max.	Min.	Mean	Max.	Min.	Mean
Tampico-Tuxpan									
<i>Norik Section</i>									
Map nos. 1-8	1.000	0.955	0.983	0.405 × 10 ⁻³	0.340 × 10 ⁻³	0.390 × 10 ⁻³	> 30,000	2,400	10,800
<i>South Section</i>									
Map nos. 9-21	0.972	0.916	0.933	0.428	0.395	0.415	1,650	323	691
" 22-4	0.933	0.854	0.889	0.455	0.415	0.435	143	93	110
<i>Isthmus</i>									
Map nos. 25-7									
Non-waxy crudes	0.918	0.865	0.901	0.445	0.428	0.430	203	92	119
Waxy crudes	0.883	0.854	0.870	0.455	0.435	0.445	132	55	93
Map no. 28	0.932	0.918	0.924	0.428	0.415	0.423	236	204	233
" 29	0.874	0.852	0.865	0.455	0.445	0.445	67	41	43
" 30-1	0.929	0.792	0.860	0.520	0.423	0.445	102	28	63

TABLE IV
Refractivity of Successive Fractions

Fraction ° C.	CORCOVADO Map no. 3			POTRERO Map no. 16			TONALÁ Map no. 25		
	D ₂₀	N ₂₀	R _g	D ₂₀	N ₂₀	R _g	D ₂₀	N ₂₀	R _g
100-120	0.729	1.4100	0.562	0.706	1.3980	0.563	0.720	1.4070	0.565
120-140	0.745	1.4220	0.566	0.727	1.4080	0.561	0.733	1.4140	0.565
140-160	0.765	1.4270	0.558	0.740	1.4170	0.563	0.748	1.4220	0.564
160-180	0.778	1.4375	0.562	0.762	1.4265	0.560	0.768	1.4315	0.562
180-200	0.796	1.4465	0.561	0.776	1.4340	0.560	0.784	1.4405	0.563
200-220	0.816	1.4560	0.559	0.796	1.4420	0.555	0.798	1.4480	0.561
220-240	0.838	1.4660	0.556	0.802	1.4470	0.557	0.813	1.4540	0.558
240-260	0.851	1.4780	0.556	0.818	1.4560	0.557	0.822	1.4600	0.559

Fraction ° C.	FILISOLA Map no. 28			TECUANAPA Map no. 29			SAN PEDRO Map ref. C		
	D ₂₀	N ₂₀	R _g	D ₂₀	N ₂₀	R _g	D ₂₀	N ₂₀	R _g
100-120	0.740	1.4155	0.561	0.709	1.4010	0.565	0.726	1.4083	0.562
120-140	0.754	1.4230	0.561	0.722	1.4115	0.569	0.736	1.4140	0.562
140-160	0.769	1.4320	0.561	0.744	1.4230	0.568	0.751	1.4220	0.561
160-180	0.791	1.4420	0.558	0.767	1.4320	0.563	0.762	1.4280	0.561
180-200	0.814	1.4510	0.554	0.787	1.4430	0.563	0.774	1.4325	0.559
200-220	0.820	1.4600	0.560	0.799	1.4500	0.563	0.783	1.4380	0.559
220-240	0.835	1.4635	0.555	0.813	1.4570	0.562	0.795	1.4430	0.560
240-260	0.844	1.4690	0.555	0.823	1.4640	0.563	0.806	1.4486	0.556

D₂₀ = Density at 20° C.

N₂₀ = Refractive index.

R_g = Specific refractivity.

This was first observed and studied by Glazebrook, Higgins, and Fannell [1, 1915-16] who postulated some kind of molecular association so as to form new molecules of higher molecular weight, to account for the increase in viscosity due to storage. From the fact that the initial viscosity can be partially restored by violent agitation, and entirely by heat treatment, just prior to the viscosity determination, it seems probable that the phenomenon is colloidal and thixotropic.

Optical Characters. Very slight laevo-rotatory activity has been observed in the light distillates, boiling below 260° C. in the case of a few Mexican crude oils, notably those

typical crudes, representative of various producing fields, is shown in Table IV.

Thermal Properties

Complete data relative to the specific heat and latent heat of vaporization for the various types of crude oil from producing fields is not available. A sample from the Tepe-tate-N. Chinampa field (Map no. 10), representing a typical light crude of mixed base, was found by the author to have a specific heat of 0.4572 between 20 and 30° C.

The calorific value of the dry crudes varies from 19,000 B.Th.U. per lb. for the light oils of the Isthmus type, to

18,250 B.Th.U. for the heavy asphaltic oils derived from the Northern Section of the Tampico-Tuxpan district, both these being gross values, uncorrected for sulphur.

The calorific values of successive fractions obtained during the distillation of a light crude on a continuous bench of 10 stills is shown in Table V, together with other relevant information.

TABLE V
Calorific value of Successive Fractions during Commercial Distillation of Light Crude Oil

	Sp. gr. 60/60° F.	Sulphur % wt.	Wax % wt.	Viscosity Red. no. 1, 100° F., sec.	Gross calorific value B.Th.U. per lb.
Original crude	0.930	3.27	4.10	780	18,750
Fraction					
1	0.704	0.49	21,184
2	0.707	0.23	21,141
3	0.721	0.21	20,817
4	0.723	0.31	20,718
5	0.746	0.28	20,558
6	0.774	0.46	..	26	20,191
7	0.796	0.66	..	28	20,121
8	0.821	0.72	0.12	30	19,950
9	0.833	1.10	0.70	33	19,836
10	0.847	1.34	1.10	35	19,606
11	0.857	1.57	1.50	39	19,514
12	0.872	1.97	3.60	43	19,483
Residue	1.005

Chemical Properties

Mexican crude oils are mainly of the mixed base type, although a certain distinction may be drawn between those from the Tampico-Tuxpan Northern Section and those from the south.

The former are predominantly asphaltic containing less than 1% of wax, while the southern oils may contain up to 5% of wax in addition to asphalt.

Oils from the Isthmus fields of Tonalá, El Burro, Teapa, and El Plan can also be divided into waxy and non-waxy types, although the latter term is purely a relative one, since

oils from all these fields contain wax. The so-called waxy crudes contain from 2 to 3.5% of wax on the average, although individual wells have been found to yield 4.5% and in one case up to 7.2%. The non-waxy oils contain less than 1%. The wax in these Isthmus crudes is frequently found to be of high melting-point and amorphous, similar in character to ceresin.

Filisola crude contains less than 1% of wax, and is more aromatic in character than the oil from the fields previously mentioned.

In the Tecuana field the oil is of a distinct type, low both in asphalt and wax. It approaches in character the Pennsylvania crude, and is the only Mexican crude so far discovered which lends itself to the production of residual cylinder stocks. Unfortunately, the field is almost exhausted.

The two Tabascan fields at Sarlat and Belem yield oils which are again of different type from the generality of Mexican crudes. They have low specific gravities and contain little sulphur, asphalt, or wax; the production from these two fields is very small.

The general analytical characteristics of typical oils from the producing fields are set out in Tables VI and VII. To facilitate comparison a uniform scheme of analysis has been adopted throughout.

Attention is directed to the column headed 'Sample and date', where the abbreviation 'C.' means that the analysis refers to the average results obtained with commercial quantities of oil during a considerable period, usually 12 months' consistent supply to a refinery or pipeline. The abbreviation 'O.F.' implies that the analysis refers to a sample or samples from the oilfield, either from a single well or a series of wells regarded as typical. The date refers to the period of observation and analysis.

All percentages are by weight and in the case of wax refer to material of the same melting-point, i.e. 125° F.

The column headed $\frac{V}{Ni}$ refers to the ratio of vanadium to nickel in the ash, it being a noteworthy characteristic of Mexican crudes that these two elements are constantly

TABLE VI
Analytical Characters, Tampico-Tuxpan, North and South Sections

(ENGLER DISTILLATION)

Crude	Map no.	Sample and date	Sp. gr.	Gravity *API.	S. %	C.R. %*	Asph. %	V.R.I. 100° F.†	Wax %	Ash %	V Ni	I.B.P. ° C.	To 150° C.		150 to 300° C.		300° C. to coke %		Coke %	Loss %
													Sp. gr.	300° C.	Sp. gr.	Sp. gr.				
Altamira	1	O.F. 1927	0.986	12.01	5.16	16.1	16.0	3,814	0.35	0.06	1.31	60	0.741	18.59	0.837	50.04	0.896	22.90	6.00	
Cacahuila	2	O.F. 1922	0.986	12.01	5.00	15.9	14.9	3,905	0.28	0.06	2.24	60	0.738	16.40	0.838	50.80	0.914	22.70	7.50	
Concovado	3	O.F. 1926	0.988	11.72	5.40	16.4	18.4	8,400	0.25	0.06	1.27	60	0.752	16.70	0.829	50.40	0.912	25.00	5.60	
Panuco	4	C. 1934	0.988	11.72	5.18	15.8	15.5	15,390	0.58	0.09	1.88	125	0.727	12.60	0.857	49.50	0.912	30.80	5.83	
Tequila	5	O.F. 1924	0.969	14.53	4.03	13.4	9.2	2,963	0.60	0.13	1.50	68	0.718	15.70	0.828	54.70	0.920	23.00	5.35	
Salinas	7	C. 1927	0.983	12.45	5.35	16.2	17.2	9,000	0.82	0.06	1.80	60	0.745	10.70	0.826	54.10	0.916	26.00	6.40	
San Diego	9	O.F. 1927	0.947	17.92	3.10	10.7	12.3	1,442	3.16	0.49	2.73	60	0.960	24.90	0.839	45.20	0.930	16.80	5.50	
Caizano	10	O.F. 1931	0.929	20.81	3.79	11.4	11.8	577	2.20	0.05	..	57	0.990	20.30	0.823	50.80	0.894	14.40	7.60	
Los Naranjos	11	C. 1934	0.927	21.14	3.67	11.7	11.5	517	3.87	0.05	2.88	78	0.920	0.713	18.30	0.794	56.30	0.880	18.50	2.70
Zacamatiste	13	C. 1931	0.931	20.49	3.76	11.3	12.1	634	2.26	0.06	..	60	0.920	0.713	21.80	0.823	50.60	0.960	14.20	5.60
Potrero	16	C. 1914	0.927	21.14	3.33	11.0	11.7	560	4.10	0.04	2.57	78	0.920	0.713	18.80	0.794	49.20	0.880	18.50	9.30
Carro Viejo	17	C. 1931	0.918	22.64	3.45	11.0	10.5	323	3.32	0.06	3.39	45	10.00	0.714	21.60	0.820	51.70	0.904	11.70	5.00
Alamo	19	C. 1923	0.921	22.14	3.10	6.6	10.1	391	1.70	0.07	..	80	5.46	0.720	23.58	0.821	52.75	0.875	22.50	5.71
Tierra Amarilla	20	O.F. 1928	0.922	21.97	3.69	11.2	11.3	660	2.65	0.04	2.16	55	8.00	0.714	20.40	0.820	52.10	0.904	12.20	3.70
Tanzhujo	21	O.F. 1928	0.962	15.59	4.19	12.7	8.5	1,650	0.77	0.07	2.36	50	7.80	0.730	21.60	0.860	50.90	0.942	14.00	6.30
Pozo Rica	22	C. 1934	0.873	30.58	1.81	5.2	2.4	57	3.88	0.04	1.41	66	11.00	0.705	23.50	0.820	52.40	0.890	6.30	4.80
Mocatepe	23	C. 1929	0.903	23.20	2.39	8.2	5.7	161	2.49	0.05	2.26	65	10.70	0.719	24.30	0.820	52.00	0.899	8.30	4.70
Furbero	24	C. 1928	0.893	26.95	2.18	7.8	4.3	112	2.30	0.03	2.03	64	13.00	0.726	24.10	0.823	49.50	0.900	8.90	4.60
San Pedro	C	O.F. 1927	0.783	49.22	0.11	0.04	..	57	25.70	0.723	61.30	0.820	51.20	0.875	0.20	1.90

* C.R. = Carbon residue (Conradson test).

† Asph. = Hard asphalt.

‡ V.R.I. 100 = Viscosity Redwood no. 1 at 100° F., sec.

present, with the exception of the Sariat and Belem oils which contain nickel but no vanadium.

In their ultimate composition, Mexican crudes are characterized by their high sulphur and low nitrogen content. Carbon varies between 79 and 84.2%, hydrogen between 9.5 and 11.2%, the average C : H ratio being 7.7.

The range of sulphur content is shown in Tables VI and VII for the oils at present produced, but higher percentages than those shown have been obtained in oils from individual wells, the maximum being 6.43%. Not only the amount, but also the nature of the sulphur compounds present in the crudes, introduces special problems in the refining of

products manufactured from them, especially in the case of the lighter distillates.

Refined Products

The quantity and quality of refined products obtainable from Mexican crude oils are naturally not subject to very close limitations, being dependent to a great extent on market requirements and the equipment available for meeting them.

Nevertheless, crudes from individual fields have been found in practice to lend themselves more readily to the manufacture of one class of products than to another,

TABLE VII
Analytical Characters, Isthmus Section

(ENGLER DISTILLATION)

Crude	Map no.	Sample and date	Sp. gr.	Gravity % API	S. %	C. %	Asph. %	V.R.I. 100° F.	Wax %	Ash %	V	I.B.P. ° C.	T _p 150° C. %	150° C.		300° C.		Sp. gr.	Coke %	Loss %
														Sp. gr.	%	Sp. gr.	%			
Tonala waxy	25	C. 1934	0.881	29.11	1.52	4.70	1.10	144°	2.20	0.03	0.95	86	11.20	0.726	27.20	0.824	52.00	0.899	5.0	4.6
Tonala non-waxy	25	C. 1934	0.892	27.13	1.64	4.76	1.20	196°	0.77	0.02	1.07	89	9.70	0.733	27.10	0.827	52.50	0.900	5.4	5.3
El Plan waxy	26	C. 1934	0.864	32.27	1.57	4.15	0.46	52°	2.80	0.04	0.86	71	17.70	0.711	28.20	0.818	48.20	0.902	3.5	2.4
El Plan non-waxy	26	C. 1934	0.916	22.98	2.10	6.20	1.24	186°	0.57	0.02	1.76	83	7.40	0.758	25.30	0.829	57.40	0.918	5.9	4.0
Teapa	27	C. 1929	0.822	40.64	1.28	1.95	0.17	35°	2.00	0.01	0.16	46	22.50	0.704	36.10	0.801	36.70	0.892	2.4	2.3
Filsola	28	C. 1934	0.924	21.64	3.57	6.37	0.66	233°	0.74	0.03	2.24	85	8.20	0.745	22.40	0.831	54.20	0.909	7.9	7.3
Tecuanapa	29	C. 1926	0.865	32.08	1.10	1.30	0.13	43°	1.20	0.005	2.03	87	10.40	0.724	30.30	0.807	51.40	0.889	5.1	2.8
Sariat	30	O.F. 1921	0.829	39.19	0.19	0.05	nil	28°	0.30	0.003	Ni only	83	21.50	0.775	62.20	0.831	15.60	0.893	0.4	0.3
Belem	31	O.F. 1929	0.792	47.16	0.04	0.06	nil	29°	2.00	0.003	Ni only	78	42.70	0.707	43.90	0.863	11.90	0.892	0.2	1.3

TABLE VIII
Typical Yields and Characters of Refined Products, Tampico-Tuxpan, North and South Fields

Crude and products	Yield % vol.	Sp. gr. 60/60° F.	I.B.P. ° C.	F.B.P. ° C.	Vol ^v %	Fl. pt. P.M. ° F.	S. % wt.	Octane C.F.R. resch.	Pour-point ° F.	V.R.I. 70° F. sec.	V.R.I. 100° F. sec.	V.R.I. 212° F. sec.	Pen. 25° C.	Duct. 25° C.	M. pt. ° F.
Panuco:															
Gasoline	3.0	0.744	69	184	18	..	0.06	56
Engine dist.	7.0	0.812	161	265	45	124	0.26
Gas oil	19.0	0.897	270	370	..	260	1.50	..	<10	55	40
Asphalt	68.0	1.043	100	>100	118
Losses	3.0
	100.0
Naranjos:															
Gasoline	11.9	0.736	48	207	21	..	0.11	43
Kerosine	12.0	0.795	170	274	36	132	0.15
Gas oil	20.0	0.850	294	375	..	208	1.00	..	<10	48	38
Spindle oil	3.5	0.915	365	20	205	99	38
Engine oil	2.5	0.932	414	30	723	251	46
Cylinder oil	4.2	0.941	475	35	..	686	61
Car oil	2.4	0.955	490	1,040	68
Wax	1.0
Asphalt	40.0	1.040
Losses	3.4	48	>100	134
	100.0
Poza Rica:															
Gasoline	15.2	0.711	40	160	45	..	0.05	52
Kerosine	9.6	0.801	175	250	28	145	0.12
White spirit	5.4	0.780	135	230	0.13
Gas oil	6.3	0.839	231	347	..	237	0.89	..	<10	..	33
Fuel oil	62.0	0.940	302	2.50	..	46	2,244	914
Losses	1.5
	100.0

Notes.—I.B.P. = Initial boiling-point. Vol^v = For gasolines, % boiling below 100° C. V.R.I. = Viscosity, Redwood no. 1. F.B.P. = Final boiling-point. Vol^v = For kerosines, % boiling below 200° C. M. pt. = Melting-point, Ring and Ball.

NATURE OF CRUDE PETROLEUM

TABLE IX

Typical Yields and Characters of Refined Products, Isthmus Fields

Crude and products	Yield % vol.	Sp. gr. 60/60° F.	I.B.P. ° C.	F.B.P. ° C.	Vol ^P %	Fl. pt. P.M. ° F.	S. % wt.	Octane no. C.F.R. resch.	Pour-point ° F.	V.R.I. 70° F. sec.	V.R.I. 100° F. sec.	V.R.I. 212° F. sec.	Pen. 25° C.	Duct. 25° C.	M. pt. ° F.
Tonala (N-W):															
Gasoline	9.8	0.731	49	208	26	..	0.05	57
Kerosine	8.7	0.817	167	274	38	128	0.12
Gas oil	17.0	0.864	200	0.70	..	<10	48	38
Spindle oil	14.6	0.901	305	163	83
Lt. engine oil	9.4	0.929	420	<10	..	388	50
Hy. engine oil	9.0	0.948	475	15	..	1,632	83
Cylinder oil	4.8	0.960	525	20	138
Asphalt	22.5	1.043	54	>100	124
Losses	4.2
	100.0
El Plan (W):															
Gasoline	22.0	0.722	45	180 ³	35	..	0.05	54
Lt. kerosine	15.0	0.802	172	266	40	130	0.16
Hy. kerosine	2.0	0.842	242	308	..	190	0.46
Gas oil	6.6	0.854	240	0.60	..	-11	42	36
Fuel oil	52.4	0.948	275	2.30	2,141
Losses	2.0
	100.0
Filsola:															
Gasoline	9.0	0.726	63	172	28	..	0.04	59
Kerosine	8.0	0.797	154	302	65	124	0.18
Gas oil	24.0	0.882	225	1.90	..	<10	50	40
Spindle oil	5.0	0.929	345	<10	229	107
Lt. engine oil	10.1	0.944	392	<10	714	255
Hy. engine oil	5.3	0.958	437	35	..	775	57
Cylinder oil	9.5	0.973	521	43	136
Asphalt	23.0	1.066	75	>100	116
Losses	6.1
	100.0

Notes.—N-W — Non-waxy crude. I.B.P. = Initial boiling-point. Vol^P = For gasoline, % boiling below 100°. V.R.I. = Viscosity Redwood no. 1. W = Waxy crude. F.B.P. = Final boiling-point. Vol^P = For kerosine, % boiling below 200°. M. pt. = Melting-point, Ring and Ball.

TABLE X

Aromatic Content of Light Fractions

Crude	Field map no.	Sp. gr. 60/60° F.	Boiling range ° C.	Aromatics % wt.	Naphthenes % wt.	Paraffins by difference
Altamira	1	0.762	40-200	14.4	37.2	48.4
"	"	0.815	163-294	28.3
San Marcos	9	0.746	58-185	14.7	41.0	44.3
"	"	0.848	172-291	40.4
Juan Casiano	10	0.723	53-182	8.7	33.8	57.5
"	"	0.800	178-267	22.0
Potrero	16	0.727	50-200	9.2	35.4	55.4
"	"	0.807	171-292	19.2
Zacamixtle	13	0.723	49-187	8.9	33.7	57.4
"	"	0.799	182-248	20.6
Mecatepec	23	0.727	51-200	8.1	36.8	55.1
"	"	0.804	181-279	19.5
Furbero	24	0.730	51-189	10.7	38.3	51.0
"	"	0.814	171-297	22.9
Teapa	27	0.720	50-201	6.0	32.0	62.0
"	"	0.789	182-268	11.8
Tecuanapa	29	0.736	50-158	5.4	50.0	44.6
"	"	0.803	158-274	19.5

owing either to the inherent qualities of their components or because they are more amenable to a certain type of refinery technique.

The heavy oils from the Tampico-Tuxpan Northern fields are eminently suitable for the manufacture of asphalt, their high sulphur content not being a detrimental feature in this respect, while their low wax content is also advantageous.

These heavy crudes can also be utilized for the manufacture of good quality lubricating oils, characterized by high specific gravity, and low pour-point.

Crude oils from all the fields numbered 9 to 21 are of mixed-base type and very similar in character from a refinery point of view.

A complete range of products, ranging from light spirits to asphalts and paraffin can be obtained from them, and they present no special problems for the refiner except those due to their high sulphur content, which in the case of the lighter products sometimes require special methods of treatment.

The three fields numbered 22 to 24 inclusive provide crude oils which are intermediate in character between those from the Golden Lane and the Isthmus regions. As with the latter, the yield of light fractions is greater and that of asphalt smaller than in the case of the northern crudes. Having a lower sulphur content, treatment of their light fractions to meet market requirements is relatively simple.

Limitation of space precludes any attempt to survey the whole range of capability in refining the various types of crude oil, but in Tables VIII and IX some typical examples are given showing the yields of products and their predominant analytical characters.

The aromatic content of the light fractions obtained from the crude oils is a matter of some interest, and in Table X are recorded the results of determinations made by conventional methods on the unrefined gasoline and kerosine fractions derived from various typical crudes.

Natural Asphalts and Seepages

The 'chappoteras' or seepages are prominent features of the oil-bearing regions of Mexico, some being still live seepages having the characteristic qualities of partially evaporated and oxidized crude oils, while others have reached the stage of complete solidification or bitumenization, and may be considered as true asphaltites.

The analytical characters of some typical examples of the latter class are as follows:

	I	II	III
Colour . . .	Black	Black	Black
Lustre . . .	Bright	Semi-lustrous	Semi-lustrous
Fracture . . .	Conchoidal	Conchoidal	Conchoidal
Streak . . .	Dark brown	Black	Black
Consistence . . .	Brittle	Brittle	Brittle
Fixed carbon . . .	21.8%	43.70%	43.5%
Sulphur . . .	10.75%	6.15%	6.20%
Soluble in CS ₂ . . .	99.94%	35.40%	29.40%
" ether . . .	44.10%
" C ₆ H ₆ . . .	99.90%	35.10%	34.20%
Wax . . .	0.43%
Ash . . .	0.30%	0.80%	0.72%
V ₂ O ₅ content of ash . . .	68.50%	31.30%	28.20%

No. I is a glance pitch, whilst II and III are Grahmites.

Natural Gas

The gas which accompanies the crude oil in the Tampico-Tuxpan region is characterized by its high content of hydrogen sulphide and carbon dioxide, and many fatalities are due to its poisonous character. Several wells in the Topila and Quebrache fields, while yielding no oil, have produced large quantities of almost pure carbon dioxide and have been exploited for the manufacture of dry ice. In the Poza Rica field the hydrogen sulphide content is very small, and on the Isthmus the oilfield gases are nearly free from this component.

The Tecuana oil is accompanied by gas which is remarkable for a small percentage of sulphur dioxide. The following analyses are typical:

	Topila	Potrero	Naranjos	Poza Rica	Filitola
Density (air=1) . . .	1.53	1.16	1.206	0.93	0.58
CO ₂ . . .	95.75%	14.00%	14.83%	16.30%	nil
H ₂ S . . .	trace	4.50	7.11	trace	nil
O . . .	0.25	..	0.71	0.10	0.6
N	8.49	..	1.4
CH ₄ . . .	2.02	36.00	..	64.50	..
C ₂ H ₆ . . .	0.05	20.00	60.61	5.40	..
C ₃ H ₈ . . .	0.13	12.00	..	7.80	98.0
C ₄ H ₁₀ . . .	0.21	7.00	2.91	3.60	..
Heavier hydrocarbons . . .	1.59	6.50	5.34	2.30	..
	100.00	100.00	100.00	100.00	100.00

REFERENCES

1. GLAZEBROOK R. T., HIGGINS, W. F., and PANNELL, J. R. *J.I.P.T.* 2, no. 5, 63 (1915-16).
2. ROBELO, C. G. *Diccionario de Aztequismos*. Cuernavaca, Mexico (1906).

VENEZUELA

By R. J. FORBES, M.N.R.I.E.

Chemical Engineer, Amsterdam Laboratory, Bataafsche Petroleum Maatschappij

THE petroleum industry did not start to exploit the Venezuelan oilfields on any large scale until about 20 years ago. Up to that time conditions had not been favourable to an unimpeded development of the industry. It is quite possible that here, as in Mexico, the natives for centuries made use of the local oil and bitumen seepages. But the period after the discovery of Venezuela in 1499 by Alonzo de Ojeda (who named the country 'little Venice' after seeing on Lake Maracaibo a village on piles) until the delivery of the country from Spanish rule by Simon Bolivar in 1811 was very turbulent and scarcely suited to promote industrial development of the country. Even after regaining their independence more than a century elapsed before there

wells are exploited by a small number of large subsidiary companies of the Standard Oil, the Royal Dutch Shell, &c. Only a small percentage of the crude produced is refined in the country itself by a large refinery of the Shell at San Lorenzo and two smaller ones at Maracaibo and Salinas; the larger part by far is exported and further refined at Curaçao, Aruba, or elsewhere. The importance of the various fields has considerably shifted during those years. Though at first Mene Grande took precedence, it was soon overshadowed by La Rosa, but both are now greatly exceeded by Lagunillas. According to Dewhurst [2, 1934], the subterranean resources, in so far as these may be estimated with any certainty, must come to some 2,000,000,000 tons, to which must be added the oil resources of East Venezuela, which, for lack of correct data, cannot yet be rated.

It is difficult to give a typical characteristic of the Venezuelan oils. Generally speaking, they belong to the heavy crudes with a low content of light fractions, they contain a good deal of sulphur, and are one of the principal sources of the present asphaltic bitumen production. A number of the most important crudes are, with their properties, given in Table I.

The Mene Grande pool yields two kinds of oil: a heavy and a light one. The productive formations are sands from the Maracaibo series of the Miocene (for the heavy crude) and the Eocene Misao-Trujillo sand (for the light crude) at a depth of 1,000 to 2,700 ft. Here too, therefore, the rule applies that the lightest crude is derived from the deeper strata. The pool was disclosed on 25 July 1914.

The two crudes are of the asphaltic type, or, as the Bureau of Mines puts it, of the naphthenic type with a high bitumen content. The light crude contains about 20% more light constituents and is further distinguished from the heavy by a higher paraffin-wax content. The composition of its light fractions is also different, being somewhat less aromatic. Otherwise the two crudes have the same asphalt content (calculated on the residue), which is a little lower than that of the well-known Mexican crudes. According to Kraemer's data [9, 1927] these crudes correspond with the heavy, high sulphur oils from Kern County, California, except for the fact that the sulphur content is lower.

A close resemblance to the Heavy Mene Grande crude is shown by the Lagunillas crude, which is also produced on the eastern side of the lake from sands of the Icoeta formation and the underlying El Mene formation, and from the La Rosa sands. The depth of the wells is between 2,300 and 5,000 ft.; the productive layers appear to have a monocline structure, by which this field, with La Rosa and Ambrosio, deviates from the other fields, which all have an anticlinal structure. The Lagunillas crude is poorer



The most important oilfields of Venezuela.

could here be any question of an important industry. And yet in 1875 Tejera, in his book *Venezuela Pintoresca*, drew attention to the fact that in the vicinity of Trujillo two oilwells were being successfully exploited and that in other states, too, similar wells were to be found. In 1878 the Government also realized the importance of the rich oil strata in Venezuela and passed the first of a series of parliamentary Acts to promote a policy of oil concessions. In 1912 this country commenced to attract the attention of the oil producers, and in 1914 Mene Grande began to be exploited seriously and the Maracaibo Valley thoroughly explored. The fact that the territory round the wide gulf (25,000 sq. miles) was so rich in oil, yielded golden profits to Venezuela when, in about 1924, owing to the general flooding of many Mexican fields that had produced large quantities of oil, there was a sudden new demand for oils of that type. This may be clearly seen from the production, which suddenly rose from 2,000 tons in 1916 and 58,213 tons in 1918 to 1,331,000 tons in 1924 [8, 1934].

The exploitation of these wells, which during the first years was practically restricted to the eastern side of the Gulf of Maracaibo, was gradually also extended to the western side and, of recent years, the petroleum industry has successfully taken in hand the exploitation of several fields in East Venezuela [5, 1934].

Now the annual production has risen to 20,252,000 tons (1930) and 17,493,000 tons in 1932, so that Venezuela produces about 10% of the total of, and is the largest producer but two in, the world [12, 1933]. Practically speaking, the

TABLE I
The Crude Oils of Venezuela

Crude	Mene Grande (Light)	Mene Grande (Heavy)	Lagunillas	La Rosa	El Mene (Western)	La Concepcion	Las Cruces (Torre)	La Paz
LOCATION	Northern part of district of Sucre, state of Zulia, east of Lake Maracaibo	North-eastern shore of Lake Maracaibo, district of Bolivar, state of Zulia	North-eastern shore of Lake Maracaibo, district of Bolivar, state of Zulia	North-eastern shore of Lake Maracaibo, district of Bolivar, state of Zulia	Western Buchivacoa concession, district of Buchivacoa, state of Falcon	District of Maracaibo, state of Zulia, west of Maracaibo	Coion District; south-west of Lake Maracaibo, state of Zulia	District of Maracaibo, state of Zulia
DISCOVERY DATE OF POOL	25 July 1914	14 May 1926	16 Dec. 1922	1920	1924	27 Aug. 1916	Dec. 1922	
PRODUCING FORMATIONS	Sands in the Maracaibo series of the Miocene produce the heavy oil; Misoa-Trujillo (Eocene) sand rock produces the light oil	La Rosa sands; Icoates formation; El Mene formation below the Icoates	La Rosa, Santa Barbara sands; Lower Miocene	Soft sandstone of Miocene age; El Mene sands	Concepcion series of Eocene; paraffin base crude	Mirador sands; third coal sands of the Eocene	Third coal series of the Eocene asphalt base	
Sp. gr. at 15/4° C.	0.900	0.950	0.950	0.910	0.840	0.850	0.870	0.890
Sulphur content	2.2%	2.45%	2.2%	1.8%	0.2%	0.7%	1.0%	2.2%
Paraffin-wax content	1.5%	0.45%	0.33%	0.7%	4.6%	3.7%	3.7%	0.5%
<i>Yields by volume:</i>								
Gasoline	14.0%	10.3%	5.7%	8.1%	40.0%	16.8%	13.5%	12.0%
Gas oil	34.5%	19.5%	14.7%	25.6%	29.0%	36.6%	30.1%	33.3%
Residue (incl. loss and water)	51.5%	70.2%	79.6%	66.3%	31.0%	46.6%	56.4%	54.7%
	100.0%	100.0%	100.0%	100.0%	100.0%	100.0%	100.0%	100.0%
<i>Gasoline:</i>								
Sp. gr. at 15/4° C.	0.725	0.752	0.758	0.725	0.764	0.752	0.720	0.720
Initial boiling-point, ° C.	47	57	60	53	58	58	48	53
Final boiling-point, ° C.	160	190	193	160	205	192	160	163
Distilling up to 100° C.	45%	21%	18%	43%	26%	22%	44%	47%
Sulphur content	<0.1%	<0.1%	<0.1%	<0.1%	<0.1%	<0.1%	<0.1%	<0.1%
<i>Gas oil:</i>								
Sp. gr. at 15/4° C.	0.835	0.854	0.860	0.837	0.874	0.835	0.819	0.840
Initial boiling-point, ° C.	172	206	208	170	221	209	171	178
Distilling up to 300° C.	85%	89%	84%	87%	78%	74%	86%	84%
Sulphur content	0.43%	0.71%	0.6%	0.45%	0.15%	0.27%	0.24%	0.84%
<i>Residue:</i>								
Sp. gr. at 15/4° C.	0.969	0.991	0.987	0.967	0.948	0.913	0.942	0.963
Viscosity, Red. no. 1, 100° F.	285 sec./140° F.	856 sec.	2,061 sec.	..
Viscosity, E/50° C.	87.2	274.7	303.0	85.7	16.2	63.9

in paraffin wax and contains a lower percentage of light fractions than the Heavy Mene Grande; the residue would also appear to be a little more aromatic. This pool, which now yields the lion's share of the Venezuelan production, was disclosed on 14 May 1926.

The second important producer is also situated on the east side. This is *La Rosa*, which produced earlier (since 16 Dec. 1922). The oil is won from Lower Miocene formations (*La Rosa* and *Santa Barbara* sands) at a depth of 1,380 to 2,600 ft. This crude greatly resembles *Light Mene Grande*, although it contains less light distillate. Here, too, the paraffin-wax content is so high that the oil is really neither asphaltic nor of the mixed-base type, but between the two; moreover, the asphalt content is a little lower than with the *Light Mene Grande*. Consequently, it is sometimes classified as a mixed-base crude [10, 1926; 9, 1927]. Kraemer, for one, compares it with the heavy mixed-base South Californian crudes, which are more volatile, however, while here the light fractions are specifically heavier, and the heavy fractions are specifically lighter.

This field projects right under the surface of the lake as the *Ambrosio* field, which yields an almost identical oil, with, however, a higher asphalt content, but an almost equal quantity of paraffin wax. It resembles the wax-bearing crudes from *Santa Maria* (South California), but

contains a little less sulphur, and the light fractions contain more aromatics.

A quite different oil is the crude from *El Mene*, also known as *Western* or *Buchivacoa*. This field, which is situated 33 miles to the east of the Lake of Maracaibo, was drilled as early as 1920, and produces from a soft sandstone of Miocene age, the so-called *El Mene Sand*, at a depth of 800 to 1,200 ft. It is a decidedly waxy crude with a very low sulphur content. The content of low-boiling constituents is higher in this than in any other Venezuelan crude. These fractions (especially the gasoline fraction) contain more aromatics than is usually found in these regions. Except for the paraffin-wax content, the lubricating-oil fractions greatly resemble those of some naphthenic Californian crudes. The residue is an excellent cracking stock. To the east of *El Mene* an entirely identical oil was struck in the *Hombre Pintado* territory at 490 to 1,660 ft. in 1927.

Another waxy crude is found in *La Concepcion*, on the west side of the lake near the town of Maracaibo. In 1924 this oil was drilled in the 1,500-2,000-ft. deep Eocene *Concepcion* series. By Kraemer this crude is (perhaps wrongly) considered to belong to the mixed-base crudes; the residue, however, is a pronounced wax residue. The lubricants made from this crude are very good. This oil bears a great resemblance to several Mid-Continent crudes (Texas, Oklahoma).

Close to La Concepcion is the La Paz pool, which was drilled in December 1922 at approximately the same depth in the middle of asphalt deposits, in the Third Coal Sands of the Eocene. The oil won here is again of a pronounced asphaltic type, strongly resembling the Light Mene Grande both in quantity and in composition of the fractions, except that the paraffin-wax content is considerably lower.

In the south-western angle of the Lake of Maracaibo there are some important fields, of which Las Cruces, also called Tarra, is perhaps the most important. The first production was obtained here as early as 27 August 1916, when oil was struck in the Mirador Sands and afterwards in the Third Coal Sands of the Eocene. The depth of these strata is from 2,300 to 4,250 ft. It is rather a heavy oil of the mixed-base type with a relatively high asphalt content; the residue contains a rather high proportion of aromatic constituents, unlike the light fractions, which have a decidedly low specific gravity.

The adjacent El Cubo field produces a crude with more

sulphur and less paraffin wax; it may be regarded as an asphaltic type.

The oilfields in east Venezuela were not opened up until recently and little has been published as yet concerning these fields and the oil found there. The crude from El Mene del Salto has a specific gravity of 0.850 and evidently resembles its namesake in the west in other respects too.

The oil from Quire-Quire seemed to have a very high sulphur content, unlike the other Venezuelan crudes, and in other respects, too, strongly resembles Panuco crude oil.

An asphaltic oil is also produced in the Guanaco field, which oil is partly employed to flux the Bermudez asphalt. The crude is very heavy (sp. gr. 0.980).

As regards the suitability of Venezuelan crudes as cracking stock, data have been published by Egloff [4, 1931, 1933].

For the sake of completeness, we must here also draw attention to some rather more theoretical investigations made of recent years into Venezuelan oil fractions, notably publications by Gullick [6, 1933] and by Lang [11, 1932].

REFERENCES

1. CIZANCOURT, H. DE. *Bull. Amer. Assoc. Petr. Geol.* 17, 211 (1933).
2. DEWHURST, T. *J.I.P.T.* 20, 281 (1934).
3. EASTBROOK, E. L., and HOLMES, J. A. *Petr. Times*, 23, 447 (1930).
4. EGLOFF, G., NELSON, E. F., and TRUESDELL, P. *Oil and Gas J.* 30, no. 10, 22 (1931); *Petr.* 2, 19, no. 14, 7-11 (1933).
5. FANNING, N. O. *World Petr.* 5, 52 (1934).
6. GULLICK, N. G. *J.I.P.T.* 17, 544-5 (1933).
7. HEDBERG, H. D. *Bull. Amer. Assoc. Petr. Geol.* 15, 229-46 (1931).
8. HULSMER, H. *Oil News*, 35, 168 (1934).
9. KRAEMER, A. J. *Oil and Gas J.* 26, no. 11, 99 (1927).
10. KRAEMER, A. J., and CALKIN, L. P. *Properties of Typical Crude Oils from the Producing Fields of the Western Hemisphere*. U.S. Bur. Mines Tech. Paper, no. 346, 9, 10, 13, 36 (Washington, 1926).
11. LANG, H. R., and JESSEL, R. *J.I.P.T.* 18, 851 (1932).
12. SELL, G. *J.I.P.T.* 19, 673 (1933).

TRINIDAD

By I. McCALLUM, B.Sc., A.M.Inst.P.T.

The Trinidad Petroleum Development Company Ltd.

The crude oil of Trinidad, although derived, with very little exception, from beds deposited in the same geological age, nevertheless shows a very appreciable range of characteristics. Formation pressures are variable, and in some cases very high, necessitating the use of artificially weighted drilling fluid with densities in excess of 2 g. per c.c. The gas produced with the oil can vary from 500 to 3,000 cu. ft. to the barrel. Generally speaking, the petroleum as a type falls between the intermediate and naphthene base classification as defined by Lane and Garton [1, 1936]. Wax-bearing crude is not common but is met with in the Lower Cruse beds and particularly in the Palo Seco district to the south.

A series of analyses representing typical crudes from the main producing areas is set forth in Table I. The distilla-

TABLE II

Company	Centres of operation
Apex (Trinidad) Oilfields Ltd. Trinidad Leaseholds Ltd.	Fyzabad. Forest Reserve, Guayaguayare, Barrackpore. Palo Seco, Los Bajos.
Trinidad Petroleum Development Co. Ltd. United British Oilfields of Trinidad Ltd. Kern Trinidad Oilfields Ltd. Trinidad Central Oilfields Ltd.	Parrylands, Lots 1 to 6, Point Fortin. Guapo, Boodoosingh. Cruse, Wilson Block, Tabaquite, Lizard Springs. San Franquique, Palo Seco.
Trinidad Oilfields Operating Co. Ltd. Siparia Trinidad Oilfields Ltd. Trinidad Consolidated Oilfields Ltd. Antilles Petroleum Co. Ltd. Petroleum Options (1925) Ltd.	Palo Seco. Fyzabad. Vessigny, Brighton. San Franquique.

TABLE I

Producing area	Major companies	Crude oil at 200° C.				Residue			Producing horizon
		Sp. gr.	Yield	Sp. gr.	Sulphur	Red. vis. at 100° F.	sec.	U. Cruse	
Forest Reserve-Fyzabad	T.L.L.	0.919	0.781	18.6	0.951	1.31	316	Forest	
	A.T.O.	0.917	0.788	20.2	0.951	1.04	284	L. Cruse	
Lot 1, Parrylands	U.B.O.T.	0.943	0.766	18.0	0.982	1.69	6,080	Lot 1	
		0.936	0.745	18.0	0.973	1.72	2,630	U. Cruse	
		0.873	0.750	26.3	0.918	1.94	261	L. Cruse	
Cruse	T.C.O.	0.895	0.757	24.0	0.936	1.65	300	Cruse	
		0.925	0.760	15.5	0.957	2.36	500	Cruse	
Guapo	K.T.O.	0.912	0.769	26.0	0.960	0.80	1,730	Lot 1	
		0.948	0.773	16.3	0.985	1.59	11,200	Cruse	
Palo Seco	T.P.D.	0.856	0.769	43.0	0.925	0.47	104	Forest	
		0.901	0.778	20.5	0.935	0.39	307	U. Cruse	
		0.881	0.771	19.0	0.909	0.32	140	L. Cruse	
Guayaguayare	T.L.I.	0.860	0.775	32.0	0.900	1.00	40	..	
Barrackpore	T.L.L.	0.935	0.785	12.0	0.957	0.70	400	Forest	
Tabaquite	T.C.O.	0.823	0.757	48.3	0.881	0.46	52	Nariva	
		0.801	0.747	47.3	0.855	0.39	45	..	

tion figures are based on the A.S.T.M. D285-33 crude-oil test. The companies are referred to by their initials only, which can be interpreted from Table II.

Table II sets forth a more detailed list of the companies in the order of their production capacities, together with their various holdings.

Forest Reserve-Fyzabad Area.

This area is the most prolific oil land in the island. Development commenced around the two major domes, on which the Forest Reserve and Bernstein pools have been proved. Drilling was continued down the north and south flanks, but most successfully to the south. Trinidad Leaseholds Ltd., the operating company, together with Apex (Trinidad) Oilfields Ltd., who have developed the eastern extension of the anticline, have in the past obtained the

bulk of their oil from the Forest and Upper Cruse sands. The exploitation, however, of the deeper Cruse sands is now yielding very satisfactory results. The crude from this area shows fairly consistent characteristics throughout. Variations, nevertheless, are found covering a specific-gravity range of 0.85 to 0.97. The Forest and Upper Cruse sands give intermediate-naphthene base crudes of similar chemical analysis. The gasoline distilled from this oil, although of low volatility, is of excellent quality and has an octane rating of 65 to 70. Petroleum from the Lower Cruse beds is usually lighter, and tends more to the intermediate base type. These deeper crudes are sometimes wax-bearing.

Lot 1, Parrylands-Cruse-Guapo Area.

This Anticline Area, a few miles north-west of the Forest Reserve field, is under exploitation by the United British Oilfields of Trinidad, the Kern Trinidad Oilfields Ltd., and Trinidad Leaseholds Ltd., who are operating the Cruse field on behalf of Trinidad Central Oilfields Ltd. The oil from this district is on the average heavier in gravity and more naphthenic in type than the Forest Reserve-Fyzabad production. Gasoline produced from Parrylands shows a rather more paraffinic nature than the average, and has a lower octane number. The highly naphthenic and viscous nature of the Kern production is particularly interesting. Intermediate fractions are practically non-existent in the crude, which, however, yields a good volatility gasoline (an unusual point considering the nature of the oil) and a very thick asphaltic residue.

Palo Seco Area.

Development in this district, carried out chiefly by the Trinidad Petroleum Development Co. Ltd., has taken place on a monocline structure, comparable with the north flank of the southern range. Drilling has successfully progressed northwards right to the synclinal axis. Early production from beds, correlated with the Forest sands of the Forest

Reserve field, yielded very light oil of specific gravity 0.82 to 0.86 with gasoline contents up to 50%. The bulk of present production is drawn from the underlying Cruse sands. The petroleum from the Lower Cruse is invariably wax-bearing, and, although generally of intermediate base, covers a range of density from 0.83 to 0.90. This crude becomes heavier and more naphthenic progressing eastward from the old centre of production. It yields a gasoline comparatively high in aromatic hydrocarbons, figures of 20 to 25% having been obtained.

Brighton-Vessigny Area.

Going northwards from Parrylands towards the Pitch Lake, the geological structure becomes more complex, and no pools of any great importance have been found. The oil produced is very viscous and has an average specific gravity of 0.96. The products distilled from the crudes of this district are generally not so sweet as the distillates from the more southerly fields, and they consequently require a greater degree of refining. At Point D'Or, to the east of the Pitch Lake, a light crude was struck showing a very high content of hydrogen sulphide. Owing to the poisonous nature of the gas the wells were considered too dangerous and were abandoned.

Guayaguayare Area.

Guayaguayare was one of the first districts to be tested in the island, but its remote position in the extreme south-east of Trinidad at the eastern limit of the southern range, has, in the past, proved a deterrent to any extensive exploitation. In addition, the area is large and the structure intricate, but there is every likelihood that the field will become one of greater importance. The oil is drawn from the Moruga and Forest sands, and possibly Cruse. It is light in specific gravity, of intermediate base, and in some cases wax-bearing.

Tabaquite Area.

The Tabaquite field, developed by the Trinidad Central Oilfields Ltd., has, in the past, been perhaps the best-known oil-producing area in the island, not so much for the size of its production as for the unique characteristics of the crude. Two types are found—the non-waxy, more from beds considered to be the Nariva sands of Miocene Age, and the deeper waxy crude, which is of doubtful origin, but may be Upper Eocene. The two crudes are very light in colour and specific gravity, and give a high yield of distillate products. Unfortunately the quantity produced is now small.

There are a number of other districts in the island which have been centres of exploitation in the past, and have, so far, failed to yield commercial production of more than a sporadic nature. Of these might be mentioned Los Bajos, Point Fortin, Barrackpore, Oropouche, and Cedros. Further exploration work continues in these areas, and doubtless there are other valuable fields yet undiscovered by the drill.

Practically the entire production of the island is processed at the two major refineries operated by the Trinidad Leaseholds Ltd. and the United British Oilfields of Trinidad Ltd., and situated at Pointe-a-Pierre and Point Fortin respectively. A wide range of products is manufactured. The local and intercolonial requirements represent a considerable market, but the bulk of the petroleum is shipped to the United Kingdom. As mentioned previously, the straight-run gasoline made is generally high in anti-knock value, is sweet, and requires very little refining. The raw kerosine distillate contains a high percentage of aromatic hydrocarbons and is treated by the Edeleanu process before marketing. Lubricating oils are not made to any great extent, but the crude should be capable of giving satisfactory yields of viscous naphthene base lubricants. In the past a considerable quantity of the crude was exported, but the refining capacity of the island has grown, and is now able to handle a throughput in excess of the normal production rate.

REFERENCE

1. LANE, E. C., and GARTON, E. L. 'Base' of a Crude Oil, U.S. Bureau of Mines, R.I. 3279.

ARGENTINE

By R. J. FORBES, M.N.R.I.E.

Chemical Engineer, Amsterdam Laboratory, Bataafsche Petroleum Maatschappij

THE petroleum industry in the Argentine has developed its present importance during the last 20 years only, although the presence of oil in that country had long been demonstrated. As far back as the seventeenth century Franciscan missionaries had already reported on oil seepages in the district of the present province of Salta.

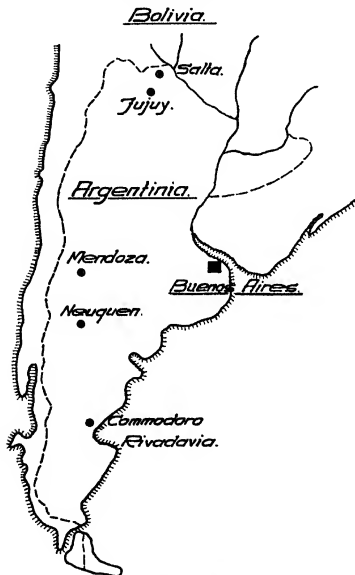

The oilfields of the Argentine.

Not until the end of last century, however, did a more accurate exploration of the oilfields start. Between 1880 and 1890 local production was developed in some of the pools. The great impetus to further exploration was, however, given by the discovery of the Comodoro Rivadavia field, when the Government drilled for water there and found traces of crude oil (1903). The first oil-well was finished in 1907; at present the Government (Y.P.F.) owns about 70% of the total production and 50% of that of Comodoro Rivadavia [5, 1932]. A more intense exploitation

followed in 1914 in the province of Mendoza (Cacheuta) and subsequently, in 1918, in Neuquen (Plaza Huincul) close by. Development of the deposits in Salta, though the first to be discovered, was not started until the year 1926. Of late years exploration parties have been investigating the value of the oil deposits said to exist in the extreme south, in Tierra del Fuego [5, 1932]. The oil production of the Argentine has rapidly risen from 6,850 tons in 1912 to 166,870 tons in 1917 and 1,884,000 tons in 1932, so that this country now occupies about the eleventh place in the world production. According to Dewhurst [1, 1934] the potential oil reserves, as far as they can be calculated with any certainty up to the present, amount to 100,000,000 bbl.

The fields in exploitation in the Argentine may be divided into three groups. Nearly all the crude oils are characterized by a low sulphur content and a paraffin-wax content varying up to a fairly high percentage. Practically all of them belong to the mixed-base type, containing besides a substantial amount of paraffin wax a fairly large quantity of asphaltic substances. This explains why, up to the present, no paraffin wax is produced in the Argentine; the residue as such is sold as a fuel, worked up into asphaltic bitumen in some cases, or cracked [6, 1931].

TABLE I

	Plaza Huincul (Neuquen) [6]	Mendoza [6]	Salta Jujuy [4]	Plaza Huincul (Neuquen) [2]
Sp. gr. at 15° C.	0.856	0.872	0.960	0.846
Pour-point, ° F.	5	55
Visc. Saybolt at 100° F.	55 sec.	71 sec.	..	21 sec.
Sulphur, % wt.	0.29	0.19	0.53	0.11
Conradson carbon, %	9.9	8.6
Paraffin wax, %	2.9
'Asphalt' (insol. in pentane, %)	9.11
% Tops	40.4	29.4
% Gas oil	16.6	15.8	17.0	..
% Lubricating oils	16.6	23.1	62.7	37.1
% Residue	26.4	31.7

A. When a closer study is made of the crude oils from the various pools, the youngest field seems to yield the most interesting. This pool lies in the provinces of Salta and Jujuy in the extreme north of the Argentine on the border of Bolivia and west of the Argentine Gran Chaco. The geology of this region is not yet presented in a satisfactory manner in any publication. Of the crudes found there, only rather vague data are known which were published by Longobardi [4, 1909, 1924] some time ago. It seems that a heavy non-waxy crude (with about 15% tops and a sulphur content of 0.53%) is to be found here side by side with a waxy crude, which is entirely free from asphaltic substances and shows a surprising resemblance to the typical Pennsylvanian waxy crude.

B. More data are known about the district in the provinces of Mendoza and Neuquen, stretched along the

chain of the Andes over 5 degrees of latitude from that of Buenos Aires. The oil mainly comes from shales of the Rhaetic Series.

Both fields give a crude of a pronounced mixed-base type with a fairly high content of paraffin hydrocarbons and also of paraffin wax (vide the pour-point). Both the high Conradson carbon test and the 'asphalt content' point to a high percentage of asphaltic substances, which presumably inhibit the winning of paraffin wax. The sulphur content is comparatively low.

These oils greatly resemble North Texas crudes, which,

however, generally contain more light fractions. According to Engler the Mendoza oil has an aromatic content of about 20%, in addition to a high percentage of naphthenes. Some typical analyses of the crudes from both pools are listed in Table I.

C. By far the most important fields are in the province of Chubut on the Gulf of St. George in the neighbourhood of *Comodoro Rivadavia*. The oil originates from the sandstone and clays of Upper Cretaceous formations. Although the crude oil is obtained from one formation, the crudes from different wells are not identical, as three types can be

TABLE II
Crude Oils of the Argentine

CRUDE:		Comodoro Rivadavia.			
LOCATION:		Territory of Chubut, near Gulf of St. George.			
DATE OF DISCOVERY OF POOL:		Oil found when drilling for water; discovery well completed in 1907.			
PRODUCING FORMATIONS:		Sandstone and clays of Upper Cretaceous. (Although the crude oil is obtained from one formation, not all the crude from the different wells is identical. Typical analyses of crudes are given below, together with the analysis of a crude blend as distilled in the refinery.)			
Type of crude oil	I	II	III	Blended	
Sp. gr. of crude at 15°/4° C.	0.868	0.910	0.922	Sp. gr. at 15°/4° C. 0.882	
Viscosity E/20° C.	7.0	E/50° C. -- 17.8	E/50° C. -- 24.0	Viscosity E/30° C. 7.2	
Pour-point	+9° C.	-2° C.	< -12° C.	Pour-point +6° C.	
				Sulphur content 0.13%	
Yields:				Yields:	
Gasoline, % by volume	15.1	9.7	4.1	Gasoline, % by volume 10.8	
Kerosine, " " "	13.3	4.8	3.2	Kerosine, " " " 12.5	
Gas oil, " " "	5.0	1.0	0.6	Light gas oil, % by volume 9.6	
Residue (incl. loss and water), % by vol.	66.6	84.5	92.1	Heavy " " " 4.8	
	100.0	100.0	100.0	Residue and loss " " " 62.3	
				100.0	
Gasoline:				Gasoline:	
Sp. gr. at 15°/4° C.	0.755	0.742	0.764	Sp. gr. at 15°/4° C. 0.745	
Initial boiling-point	57° C.	66° C.	70° C.	Initial boiling-point 64° C.	
Final boiling-point	200° C.	198° C.	200° C.	up to 100° C. 12%	
Sulphur content	0.06%	traces	0.01%	Final boiling-point 192° C.	
Aromatics	13.5% wt.	9.0% wt.	13.5% wt.	Sulphur content 0.02%	
Kerosine:				Kerosine:	
Sp. gr. at 15°/4° C.	0.816	0.818	0.840	Sp. gr. at 15°/4° C. 0.803	
Viscosity, 20° C.	1.81 cp.	1.80 cp.	1.96 cp.	Initial boiling-point 178° C.	
Aromatics	13.9% wt.	10.3% wt.	17.0% wt.	up to 200° C. 25%	
Sulphur content	0.07%	0.01%	0.03%	Final boiling-point 272° C.	
Initial boiling-point	202° C.	203° C.	204° C.	Flash-point 53° C.	
Final boiling-point	280° C.	278° C.	284° C.	Sulphur content 0.02%	
Gas oil:				Light gas oil:	
Sp. gr. at 15°/4° C.	0.839	0.852	0.870	Sp. gr. at 15°/4° C. 0.840	
				Initial boiling-point 244° C.	
				up to 300° C. 70%	
				Final boiling-point 357° C.	
				Flash-point 108° C.	
				Pour-point < -12° C.	
				Sulphur content 0.08%	
Residue:				Heavy gas oil:	
Sp. gr. at 15°/4° C.	0.906	0.940	0.931	Sp. gr. at 15°/4° C. 0.850	
Viscosity, E/50° C.	9.5	80.0	35.5	Initial boiling-point 276° C.	
Flash-point, P.M.	140° C.		130° C.	up to 300° C. 31%	
Pour-point	+21° C.	+18° C.	+2° C.	Flash-point 134° C.	
Sulphur content	0.44%	0.02%	0.06%	Pour-point +3° C.	
				Sulphur content 0.11%	
				Residue:	
				Sp. gr. at 15°/4° C. 0.927	
				Flash-point 188° C.	
				Visc. Red. no. 1 at 100° F. 350 sec.	
				Pour-point +24° C.	
				Sulphur content 0.15%	

distinguished. Analyses of these typical crudes are given in Table II, together with the analysis of a crude blend as distilled in the refinery of the Shell at Buenos Aires. Although this is not quite certain yet, the lightest type seems to occur in the deepest strata and the oil becomes heavier the higher the stratum. The analyses in Table II show, moreover, that the character of the oil changes as well.

Type I (Table II) has a low content of asphaltic substances in comparison with the others; the rather low specific gravity of the residue points to the presence of paraffin wax and of a high percentage of non-aromatics (naphthenes). The low-boiling fractions contain a moderate amount of aromatics; the crude as a whole is poor in sulphur. There is some resemblance between this oil and that of East Texas; it is a mixed-base crude. The blend distilled is mainly made up from this crude Type I, the

other types contributing less to the specific properties of the blend.

Type II occupies a medium position to some extent, forming a transition to Type III, which besides much less paraffin wax contains more asphaltic substances, although II seems to contain more high-boiling aromatics. Neither of these oils are of the genuine non-waxy crude type, however, which is usually the initial material for the manufacture of bitumen and is therefore often called 'asphaltic crude'. These two oils are more like the South Californian crudes, which, however, contain more light constituents and especially more sulphur.

The nature of all these Comodoro Rivadavia crudes is such as not to warrant a further working up of the residue into paraffin wax or asphaltic bitumen. The lighter fractions present no difficulty in the ordinary course of distilling and refining.

REFERENCES

1. DEWHURST, T. *J.I.P.T.* 20, 281 (1934).
2. HUNTER, C. M. *J.I.P.T.* 10, 829 (1924/5).
3. KRAEMER, A. J., and CALKIN, L. P. *Properties of Typical Crude Oils from the Producing Fields of the Western Hemisphere*. U.S. Bur. Mines Tech. Paper, no. 346, pp. 34-5 (Washington, 1926).
4. LONGOBARDI, E. *Algunas invest. sobre los petroléos argentinos* (Buenos Aires, 1909). *El Petroléo de El Quemado. Anal. Assoc. Quím. Argentina*, 11, 365-8 (1924).
5. MALAMPHY, M. C. *Oil Weekly*, 68, 12 (1932).
6. NELSON, E. F., and EGLOFF, G. *Oil and Gas J.* 30, no. 23, 22 (1931).
7. SELL, G. *J.I.P.T.* 19, 673 (1933).

COLOMBIA, PERU, AND ECUADOR

By G. EGLOFF, M.A., Ph.D.

Universal Oil Products Company

Colombia

THE Infantas oilfield in Colombia has been producing oil for 14 years, the La Cira for 6 years, and in 1933 the first crude oil in the Petrolia area was reached at a depth of 490 ft. The average depth of the Infantas and La Cira fields is 1,512 ft.

Tests of the crude samples from these fields show about 27° API. gravity for Infantas, 25° API. for La Cira, and 42° API. for the Petrolia crudes. The first commercial well in the Petrolia area produced at a depth of 668 to 708 ft. with a daily production of 2,500 bbl.

The total Colombian production during 1935 was 17,595,000 bbl.; one refinery in Colombia treats 6,000 bbl. of crude daily with no cracking installations.

TABLE I

Crude Analysis

Gravity, °API.	42
Viscosity at 100° F.	32
Pour-point, °F.	below 30
Colour	light green
Colour (N.P.A.)	6.5
Sulphur, %	0.16
Distillation:	
Gasoline, %	52
Distillate and gas oil, %	2
Fuel oil residuum, %	25

Pink and red neutrals are obtained from the heavier fractions.

Colombian Crude Oils

Refined oil:	Maximum refined	Minimum refined
Yield, %	21.5	5.6
Cut range, %	(10.0-31.5)	(16.4-22.0)
Gravity, °API.	37.2	38.1
Viscosity (R.O.), °F.	7	450
Ring no.	4	11
Sulphur, %	0.167	0.088
Copper no.	1	1
Flash-point (Abel), °F.	135	150+

TABLE I (cont.)

Refined oil:	Maximum refined	Minimum refined
Distillation:	°F.	°F.
Initial b.p.	348	405
% distilled over:		
10	382	420
20	398	423
30	421	425
40	439	427
50	456	429
60	474	431
70	492	433
80	512	438
90	535	446
End-point	562	471

Other products:	Gas oil	Lube oil	Bottoms	Narrow lube cut
Yield, %	26.6	15.0	42.0	2.6
Cut range, %	(16.4-43.0)	(43.0-58.0)	(58.0-100.0)	(55.4-58.0)
Gravity, °API.	31.8	23.2	13.0	21.1
Flash-point, °F.	390	540	390	390
V/100	40.7	413	..	835
V/210	46.1	1,668	64.4
Cloud, °F.	below -60
Pour-point, °F.	below -60	-35	75	-15
An. pt., °F.	149	171	..	183
Bomb sulphur, %	0.40
V.I.	26
Diesel index	47.4
Neut. no.	2.90	1.50

Peruvian Crude Oils

The Lobitos crude from Peru is non-waxy and is characterized by a high-gravity, high-gasoline content. The total gasoline content ranges from 34 to 42.3%, depending upon the sample. The sulphur content varies from 0.07% in one sample to 0.12% in another. There are two refineries in Peru having a total daily capacity of 17,000 bbl. with 6,800 bbl. daily cracking capacity.

TABLE II Peruvian Crude Oils

Fractions removed:	Lobitos crude			El Condor crude				
	None	392° F. gasoline	Topped crude	None	300° F. gasoline	350° F. gasoline	400° F. gasoline	Topped crude
<i>Hempel distillation</i>								
Yields, vol. % of crude	100.0	34.0	65.0	100.0	22.3	30.6	37.7	77.2-68.9-61.8
<i>Properties of fractions</i>								
Gravity, °API.	36.7	57.1	26.9	37.2	61.5	58.0	55.0	28.2
Sp. gr. at 60° F.
Colour, ° Saybolt	30
Copper dish gum, mg. per 100 c.c.	3
Doctor test	negative
Sulphur, %	0.07	0.02	0.10
Octane number (C.F.R. Motor Method)	60	66	62	57	..
Flash-point (Cleveland Open Cup), ° F.	190	210
Fire (Cleveland Open Cup), ° F.	220	235
Flash-point (Pensky-Martens), ° F.	180	200
Viscosity (Universal), sec. at 100° F.
Viscosity (Universal), sec. at 122° F.
Viscosity (Furol), sec. at 77° F.	10	..	17
Viscosity (Furol), sec. at 122° F.	15
B.S. & W., %	trace	..	trace	trace
Cold test, ° F.	10	..	below 0	below 0

TABLE II (cont.)

Fractions removed:	Lobitos crude			El Condor crude					
	None	392° F. gasoline	Topped crude	None	300° F. gasoline	350° F. gasoline	400° F. gasoline	Topped crude	
<i>Engler distillation</i>									
Initial b.p.	°F. 176	°F. 148	°F. 395	°F. 160	°F. 121	°F. 126	°F. 138	°F. 428	
% distilled over:									
5	238	177	424	212	170	176	188	462	
10	269	194	449	240	182	192	205	478	
20	330	214	482	294	196	210	225	510	
30	386	252	524	350	206	222	241	518	
50	535	255	629	494	220	248	270	644	
70	688	328	726	654	235	275	303	732	
90	..	389	261	313	352	..	
End point	300	350	401	..	
Total % over	99.0	98.0	99.0	98.5	98.0	99.0	99.0	98.0	
% bottoms	..	1.0	1.0	1.0	1.0	..	
% coke by weight	1.2	..	1.5	1.6	2.3	
% loss	..	1.0	1.0	
% at 400° F.	31.0	37.5	
% at 410° F.	33.0	..	3.0	
% at 437° F.	36.5	..	8.0	42.5	2.0	
% at 572° F.	56.0	..	40.0	60.0	35.0	

Ecuador

Crude oil from Ecuador has an API. gravity of 41. The crude produces 40.2 of 400° F. end-point gasoline having an octane rating of 54. The sulphur content is low, being about 0.05% in the sample whose analysis is given.

There are three refineries in Ecuador having a combined daily capacity of 850 bbl. of crude with no cracking installations.

Analysis of these crudes are given in Table III.

TABLE III
Ecuador Crudes

Source:	Santa Elena					Montevideo-Uruguay						
	Entire crude	301° F. gaso-line	350° F. gaso-line	400° F. gaso-line	Kero-sine	Bottoms		Entire crude	301° F. gaso-line	401° F. gaso-line	Kero-sine	Bottoms
		After 350° F.	After 400° F.	After 350° F.	After 400° F.							
Yields, vol. % of crude	100.0	23.2	32.5	40.2	15.0	67.2	44.7	100.0	22.5	39.9	15.8	76.8 and 44.3
Gravity, °API.	41.2	63.2	38.7	57.6	42.0	33.8	29.5	40.8	63.0	56.0	41.4	29.5
Sp. gr. at 60° F.	0.8193	0.726	0.744	0.749	0.816	0.8560	0.8789	0.8212	0.7275	0.7547	0.8184	0.8789
Colour, ° Saybolt	17
Doctor test	..	neg.	neg.	neg.	neg.
Sulphur, %	0.05	0.01	0.03
Octane number	..	65	58	54
Flash-pt., Pensky-Martens	165
B.S. & W., %
Cold test, °F.
Initial b.p., °F.	142	103	120	110	399	380	520	142	113	131	421	532
A.S.T.M. 100 c.c. distillation:												
% over, °F.												
5	198	128	154	148	408	410	540	215	148	172	430	560
10	238	140	173	172	413	424	552	249	164	192	433	565
20	290	167	200	204	420	464	578	303	185	223	438	585
30	346	184	220	227	424	494	603	363	201	243	445	613
50	478	207	250	262	436	580	666	482	223	277	453	669
70	615	230	278	302	452	684	740	617	241	313	467	709
90	714	260	314	346	479	760	..	740	270	363	495	721
End point	720	301	350	400	524	760	760+	752	301	401	525	751
% over	98.5	97.5	97.5	98.0	99.0	99.0	99.0	98.0	98.0	98.0	98.5	98.0
% bottoms	..	1.4	1.4	1.3	1.0	1.0	1.0	..	1.0	1.0	1.5	..
% coke and coke	1.4
% loss	1.0	2.1
% at 400° F.	38.5	2.0	..	37.0
% at 410° F.	38.5
% at 572° F.	64.0	64.0	13.0
% at 212° F.	..	56.0	26.0	25.2

JAPAN

By MASAKICHI MIZUTA, B.Sc.

Managing Director, Nippon Oil Company, Japan

The oil-producing districts of Japan extend over several locations in the shape of a very long belt from Formosa in the south to Hokkaido in the north. A wide variety of crudes are produced, as shown by the following tables, which give the salient physical and chemical properties of all the important crudes which are worked.

	Depth metres	Specific gravity at 15° C.	Acid value	Carbon residue %	Nitrogen %	Sulphur %	Paraffin %
FORMOSA FIELDS:							
Shukoko . . .	252 955	0.828 0.888	0 0.066	0.011 0.118	0.050 0.082	0.126 0.154	2.484 7.529
NISHIYAMA FIELD:							
Class No. 1 (Deep Bed)	873 1820 204	0.805 0.853 0.834	0.027 0.085 0.022	0.106 0.099 0.125	0.084 0.210 0.091	0.161 0.245 0.162	0.934 1.441 2.017
Class No. 2 (Intermediate)	996 173	0.864 0.889	0.182 0.046	0.117 0.074	0.117 0.218	1.100 1.125	
Class No. 3 (Shallow Bed)	10 896	0.810 0.805	1.318 1.548		0.254 0.268	0.454 0.375	
OMO FIELD:	475 919	0.874 0.897	2.021 0.389	1.654 3.214	0.194 0.234	0.158 0.535	0.375 0.504
HIGASHIYAMA FIELD:							
Uraue . . .	121 285	0.860 0.882	0.184 0.258	2.682 3.080	0.262 0.257	0.582 1.566	1.156 2.060
Hire . . .	231 204	0.838 0.864	0.158 0.174	2.715 2.787	0.239 0.289	0.579 0.691	1.081 1.661
Katsubo . .	224 351	0.869 0.876	0.253 0.286	2.743 2.914	0.282 0.284	0.691 0.609	0.661 0.216
Katsurazawa	140 424	0.873 0.898	0.232 0.139	2.841 3.613	0.284 0.355	0.609 0.919	0.216 1.366
Miyaji . . .	296 873	0.889 0.873	0.271 0.189	2.584 2.758	0.378 0.588	0.136 1.366	
NITTSU FIELD:							
Tenindoiri	..	0.934	0.473	2.516	..	0.442	0.257
Koya	0.896	0.130	0.884	..	0.353	0.465
Takiya	0.926	0.383	2.485	..	0.448	0.795
Shiodani	0.887	0.121	0.607	0.171	0.304	0.260
Sakazawa	0.923	0.538	1.261	..	0.380	0.888
Yamaoyawari	..	0.889	0.271	2.584	..	0.378	0.136
Kumazawa	0.938	0.738	4.837	..	0.540	0.693
Kanzu	0.945	0.601	3.523	0.328	0.515	0.473
Oguchi	0.925	0.334	1.046	..	0.360	0.433
Umayoe	0.917	0.637	3.850	..	0.540	0.716
Kodani	0.943	0.800	2.651	0.310	0.447	0.352
Asahi	0.948	0.918	3.260	..	0.464	0.716
Amagasaki	0.930	0.405	3.657	0.419	0.544	0.448
Yashiroda	0.947	0.764	6.654	..	0.741	0.510
Tsubakidani .	..	0.887	0.187	3.164	0.411	0.410	0.127
Higashitama .	..	0.972	0.444	7.178	0.414	0.703	1.152
Garamaki	0.940	0.188	2.717	..	0.458	0.431
..	..	0.942	0.445	4.572	..	0.515	0.674
..	..	0.890	0.245	3.643	0.351	0.516	0.323
..	..	0.937	0.469	4.707	..	0.567	0.959
..	..	0.859	0	1.051	0.394	0.323	0.190
..	..	0.957	1.130	7.208	0.418	1.035	2.361
..	..	0.953	1.255	4.803	..	0.752	0.278
..	..	0.976	0.522	6.973	..	0.897	0.970
..	..	0.956	0.565	7.624	..	0.562	0.288
..	..	0.878	0.129	4.174	..	0.488	0.466
..	..	0.939	0.500	7.280	..	0.935	0.675
..	..	0.851	0	1.952	0.204	0.317	0.247
..	..	0.923	0.277	2.329	..	0.359	1.686

	Depth metres	Specific gravity at 15° C.	Acid value	Carbon residue %	Nitrogen %	Sulphur %	Paraffin %
AKITA FIELD:							
Class 1 (Mean value)	..	0.866	0.189	2.743	0.282	0.599	1.310
Kaite . . .	221	0.845	0.076	2.974	0.284	0.544	1.375
Toyoiwa . . .	789 249	0.884 0.834	0.154 0.190	3.426 3.923	0.320 0.357	0.781 0.871	2.802 1.010
Katurane 1 .	57	0.855	0.339	1.996	0.325	0.713	1.488
Katurane 2 .	102 198	0.906 0.853	0.685 0.130	3.560 1.491	..	0.782 0.466	1.054 0.980
Katurane 3 .	285	0.832	0.148	1.408	0.168	0.553	0.757
Katurane 4 .	345 791	0.879 0.853	0.180 0.077	2.303 1.684	0.190 0.328	0.571 0.512	1.049 1.280
Uchimichikawa and Hanakawa	876	0.885	0.452	2.645	..	0.560	2.268
Type 2 (Mean value)	181	0.870	0.119	3.237	0.207	0.602	1.719
Class 2	..	0.858	0.090	2.835	0.197	0.536	1.534
Type 1	700	0.880	0.181	4.515	0.221	0.642	2.103
Asahikawa No. 1 .	125	0.886	0.248	4.827	0.461	0.627	0.536
Asahikawa No. 2 .	150	0.910	0.562	3.371	0.371	0.547	1.247
Asahikawa No. 3 .	240	0.904	0.609	3.670	0.502	0.511	0.854
Nigorikawa . .	336	0.912	0.352	4.209	0.381	0.703	0.509
Nishikawa . . .	134	0.910	0.276	4.815	0.415	0.586	0.310
Type 2	331	0.961	0.985	5.350	..	0.702	0.514
Kimshoji . . .	746	0.934	0.372	6.008	0.601	0.798	0.408
Michikawa . .	754	0.937	0.454	7.824	..	1.026	0.322
Kurokawa . . .	184	0.961	3.05	5.047	0.499	0.726	0.328
Toyokawa and Uryama	291	0.973	0.937	7.841	0.589	0.841	0.459
HOKKAIDO FIELD:	800	0.902	0.305	3.973	0.406	0.569	2.203
Furui . . .	69	0.842	0	0.490	0.062	0.184	0.132
Karunai . . .	784	0.944	0.209	1.421	0.078	0.258	0.986
Ishikari . . .	308	0.814	0.023	0.748	0.063	0.193	0.228
Ishikari . . .	418	0.887	0.248	0.971	0.217	0.481	0.681
Gonosawa . . .	19	0.766	0	0.262	0.066	0.157	0.502
Hachinosawa .	208	0.832	0.042	0.542	..	0.174	1.095
Shumetsu . . .	22	0.766	0.009	0.262	0.066	0.173	0.502
..	174	0.820	0.037	0.681	0.104	0.228	1.194
..	19	0.802	0	0.413	0.070	0.157	0.792
..	127	0.832	0.032	0.692	0.073	0.198	1.491

Summarizing briefly we find that:
Formosa crudes contain the highest contents of paraffin. They are almost identical in nature, and irrespective of their locality or depth, they all appear to be related to the same mother oil zone. They are very volatile and contain about 40% gasoline and 35% kerosene.
Nishiyama fields comprise one of the richest oil-bearing

strata in Japan. They can be classified into Shallow, Intermediate, and Deep Bed crudes, although they are essentially similar in character. As the depth decreases the paraffin content is smaller, and such shallow bed oils are considered fit for lubricating oils without processing. They contain about 30% each of gasoline, kerosine, and lubricating oil. Probably all these crudes are of the same origin and belong to one and the same oil-bed.

Omo and Higashiyama fields give rise to somewhat similar dark brownish-black crudes, with relatively high wax contents. They yield roughly 20% gasoline, 25% kerosine, and 30% or more of lubricating oil.

Niitsu crudes are found in great variety. They are much more viscous than other crudes and give practically no gasoline, but large kerosine and lubricating oil yields. The Garameki crude appears to differ from the remaining Niitsu crudes, and either its origin must differ or it has undergone separate metamorphosis.

Akita crudes may be classified into the light and heavy varieties. Those under class 1 are less asphaltic, more waxy, but give higher gasoline and kerosine yields than the class 2 variety, which give little or no benzene, but higher lubricating oil yields.

Hokkaido crudes are of good quality and are mostly obtained from Shallow Reservoir Rocks. They resemble fairly closely in nature and geological origin the Formosa crudes. They are generally poor in oxygen, nitrogen, and sulphur, consequently having low asphalt content. They appear to originate from four distinct oil zones.

A comprehensive study has been made of the yields of semi-finished products obtainable from each type of Japanese crude. Whereas the American Bureau of Mines standardizes the distillation up to 300° C. at 40 mm. pressure, it was found that exactly comparable results could be obtained with less fear of cracking by distillation

up to 270° C. at 10 mm. pressure. The following table shows the results of cutting various fractions from the distillate produced from each typical crude up to 270° C. at 10 mm. pressure:

	Distillate (% up to 270° C. at 10 mm. pressure)	Yields from distillate						
		Gasoline %	Kerosine %	Light oil %	Lab. oil total %	Light lub. oil %	Medium lub. oil %	Heavy lub. oil %
FORMOSAN FIELDS:								
Shukkoko crude	95.98 up to 245°	40.90	35.14	7.14	16.66	9.28	3.52	3.86
NIITSU FIELDS:								
Class 1 crude	91.15	36.22	30.71	7.54	24.86	9.39	7.29	8.18
Class 2 crude	91.48	25.27	37.28	9.40	27.58	11.22	8.31	8.05
Class 3 crude	87.13	15.87	29.27	14.42	39.80	14.89	12.68	12.23
OYO FIELDS:								
Omo crude	79.22	13.75	32.92	10.11	42.67	12.02	10.42	20.23
HIGASHIYAMA FIELDS:								
Higashiyama crude	78.18	23.51	25.50	8.06	42.63	10.76	10.35	21.52
NIITSU FIELDS:								
Class 1 crude	86.15	2.43	39.50	15.05	42.85	17.19	11.98	13.68
Class 2 crude	65.98	..	16.73	14.75	68.03	17.71	16.79	33.53
Class 3 crude	61.21	..	16.62	12.10	70.83	16.90	15.59	38.34
Class 4 crude	60.03	..	12.83	13.54	73.34	17.09	16.37	39.68
Class 5 crude	65.27	..	18.70	15.21	65.87	16.73	14.63	34.51
Garameki crude	85.03	26.50	27.40	10.35	35.50	10.60	10.18	14.72
AKITA FIELDS:								
<i>Class 1 crudes</i>								
Type 1	76.52	23.09	26.51	8.25	41.77	9.72	8.95	23.10
Type 2	77.66	22.23	24.70	9.65	43.08	10.49	10.59	22.00
<i>Class 2 crudes</i>								
Type 1	65.08	6.26	22.12	10.26	60.65	13.58	12.86	34.21
Type 2	57.19	0.70	18.93	10.40	69.54	13.01	14.15	42.38
HOKKAIDO FIELDS:								
Fureol crude	88.25	26.09	26.68	11.19	35.66	13.86	10.43	11.37
Karunai crude	89.33	40.35	22.75	7.25	29.45	9.91	9.07	10.47
Ishikari crude	95.76	57.24	23.33	4.83	14.35	6.27	4.09	3.99
Kiurui crude	82.09	0.38	28.68	18.81	51.76	19.36	14.86	17.54

DUTCH EAST INDIES

By R. J. FORBES, M.N.R.I.E.

Chemical Engineer, Amsterdam Laboratory, Bataafsche Petroleum Maatschappij

THE crude oils of the Dutch East Indies vary in character very widely, but it may be said with a certain degree of accuracy that they have the following properties which might be called typical:

1. Most of the oils are very light, 50% of the crude oil often consisting of the lowest boiling fractions (gasoline and kerosine), in some types (Sumatra) sometimes even more than 70%.
2. The relatively high specific gravity of the different oil fractions (see Table) directly points to a high content of aromatic hydrocarbons, which is often accompanied by a high percentage of naphthenes.
3. Generally speaking, the sulphur content may be termed very low.
4. Some crudes display a very high paraffin wax content, which makes them pre-eminently suitable for the manufacture of this valuable product. Naturally these oils have a high pour-point and other characteristics of waxy crudes.

Generally speaking, in drilling, the order of the type of crude oil met from the surface downwards is as follows:

First comes a heavy non-waxy crude (sometimes called 'asphaltic crude'), then a lighter oil of the same type, and, finally, in the deepest strata a waxy crude, which usually gets lighter as one drills to a greater depth.

This rule was first found by Jezler and confirmed later by several writers such as Dunstan [2, 1924-5], Kewley [4, 1920-1], and others. It stands to reason that in some places only one, or two, of these types of oil are found or exploited. Moreover, this only applies to the islands of Borneo, Java, and Sumatra, since, in the eastern islands of the Archipelago, in the Moluccas, quite different types of oil are found. Thus, for instance, the 'Ceram crude' is a heavy non-waxy oil with a considerable sulphur content; the lighter fractions, as far as they are present, have a pronounced naphthenic character, corroborated by their high specific gravity (see No. L, Table). It is, however, only produced in small quantities.

Of the East Indian oils the 'Borneo crudes' are the ones that have been most minutely examined and discussed in recent publications. A very clear survey of the data has been drawn up by Kewley [4, 1920-1].

In Balikpapan comparatively little of the heavy, viscous, 'non-waxy crude' is found; considerable quantities of the lighter, 'non-waxy crude' (see Table, col. H) are produced from deeper strata. This crude contains no paraffin wax. Even one of the first investigators, Steuart, suspected that the high specific gravity of the various fractions, if compared with the equivalent fractions from other oils, would point to a very high content of aromatic hydrocarbons, which must, according to him, greatly exceed the usual limit of about 15%. This was afterwards confirmed by later writers, as Jones [3] and Tausz [9], who were able to identify a large number of constituents of the lighter fractions. Benzene, toluene, and higher homologues, naphthalene derivatives, cyclic hydrocarbons, decalin and tetralin, &c., are found, so that eventually the conclusion was drawn that this crude must consist of approximately equal quantities

of aromatics, naphthenes, and paraffins. Tizard was able to support this assumption by the aid of his aniline point method; he found, for instance, that a crude of this type was composed of 26% of paraffins, 35% of naphthenes, and 39% of aromatics.

This high aromatic content was at first a drawback to the gasoline fraction produced in Borneo during the time that these products were still bought by specific gravity. When, however, a high H.U.C.R. came to be appreciated, these gasolines in particular were highly valued.

The fairly considerable 'toluene fraction' was used to a certain extent in Europe for the manufacture of T.N.T., in Germany, England, and in France (*Nature*, p. 832 (1921)).

The aromatic content was also a drawback to the kerosine fraction from Borneo crudes owing to the type of lamp in general use with the consumers. When the Eddeleanu process came to be applied in Borneo, this defect was easily remedied.

The Balikpapan 'waxy crude' (Table, K) contains an average of about 8% of paraffin wax; its chemical composition is about the same as that of the 'non-waxy crude' described above, the only difference being that its aromatic content is usually a little lower. Its high wax content makes the topped residue of this crude (usually called 'wax-residue') pre-eminently suitable for the manufacture of paraffin wax [4].

The Tarakan crude (Table, M) is of the heavy, 'non-waxy' type. Its high flash-point (100° C.), low viscosity and pour-point, and low coking value stamp this oil as an excellent liquid fuel. The crude is directly sold as such and so not first distilled. The chemical composition corresponds to the non-waxy Balikpapan crude, but its aromatic content is somewhat lower (about 32%) and the naphthene content just as much higher. In Tarakan a waxy crude [4, 1920-1] has also been found at a greater depth, which does not play a part in the production yet.

The Miri crudes are of a special character; Kewley has devoted several essays to them [2, 1924-5; 5, 1924-5]. The upper strata yield a reddish-brown 'non-waxy crude' (see Table, col. N), which is distinctly naphthenic and free from wax and asphalt. Its high specific gravity and refractive indices, together with the low viscosity, point to a low percentage of paraffinic hydrocarbons, while upon investigation of the lighter fractions it appeared that these only contained 5% of aromatics. Therefore we must infer from these observations that it is a crude consisting practically entirely of naphthenes. Olefines could not be found, but the high formolite figures point to the presence of unsaturated cyclic compounds [5, 1924-5].

The kerosine fraction as a rule burns less well than equivalent fractions from other oils: it has a pronounced tendency to smoke and burns with a reddish flame. The fuel is a fair Diesel oil, however, and may be worked up to good lubricants of the normal naphthenic type; these are easy to refine and their colour stability is good. Strange to say, the heaviest lubricating-oil fractions dissolve practically completely in absolute alcohol and they may readily be nitrated [2, 1924-5; 5, 1924-5].

In Miri, too, generally speaking, the content of lighter fractions in the crude increases with the depth of the oil-bearing stratum. Here, too, in the deepest strata, waxy crudes are found, which sometimes contain as much as 4% of paraffin wax. The *Seria Brunel* crude (Table, P) resembles that of Tarakan in many respects; it also contains much fewer light fractions than the Miri oils.

Of the *Java* crudes those from Wonokromo (Sourabaya) are generally of a heavy 'non-waxy' type; those from Tjepoe (Rembang) show several variations of a waxy crude. Although little has been published about the composition of the *Java* crudes, we know from a thesis by Dengler [1, 1893] that the non-waxy crude has a very high content of naphthenes, which Dengler, with the imperfect method of research of his times, estimated to be upwards of 50%, so that, according to him, this oil almost equals that of Baku. This type of oil (Table, G) is, after topping, a very good liquid fuel and was formerly successfully used for the manufacture of lubricants.

The crudes from *Rembang* are practically all of the waxy type, containing an average of as much as 8% of paraffin wax, and are therefore especially suited for the manufacture of this product. Here, too, naphthenes preponderate, while a moderate percentage of aromatics is also found. Olefines and homologous unsaturated compounds are not found in them [10, 1900], though in the lighter fractions (boiling at c. 190°C.) one does find substances that show laevo-optical

rotation. This has also been observed in other crudes giving rise to a controversy as to whether crude petroleum may be regarded as derived from substances containing cholesterol.

For refining purposes there are usually distinguished light (Table, E) and heavy (Table, F) waxy crude, which chiefly differ in their percentage of lighter fractions. The general high content of low-boiling constituents greatly simplifies the production and refining of the different commercial types of gasolines and kerosines.

This also applies to the *Sumatra* crudes which are almost exclusively of the waxy type; the heavy waxy crude remains of secondary importance, the lighter types being predominantly produced.

As a rule, the crudes from *Pangkalan Brandan* (Table, A) are lighter than those from *S. Sumatra* (Table, B, C), but their composition is practically identical, as they contain not only paraffin hydrocarbons and many low-boiling naphthenes, but also a fairly high percentage of aromatics (about 20%).

Hence nowadays the crude kerosine is often treated by the Edeleanu process. Ragusin [6, 1903] found in the gasoline fraction 5-6.5% of benzene and toluene, in higher fractions mesitylene, pseudo-cumene, and so on. The method by which the crude is refined is directly determined by the high content of low-boiling constituents; a further treatment of the residue is only required or desirable in special cases.

REFERENCES

1. DENGLER (and ENGLER). Dissertation, Karlsruhe (1893).
2. DUNSTAN, A. E. and KEWLEY, J. *J.I.P.T.* 10, 486 (1924-5).
3. JONES, H. O. and WOOTON H. A. *J.C.S.* 91, 1146. (1907).
4. KEWLEY, J. *J.I.P.T.* 7, 209 (1920-1).
5. — *J.I.P.T.* 10, 43 (1924-5).
6. RAGUSIN, A. V. *Oesterr. chem.-techn. Ztg.* no. 7 (1903).
7. — *Petroleum Review*, 460 (1902), and 3 (1903).
8. STEINKOPF, W. and BEIRSDORF, F. *J. prakt. Chem.* 101, 75 (1920).
9. TAUSZ, J. *Z. angew. Chem.* 32, 361. (1919).
10. ZALOZIECKI. *Naphtha*, 222 (1900).

BURMA

By W. J. WILSON, F.I.C., A.C.G.I., and G. R. NIXON, B.Sc., A.R.C.S.
Research Department, The Burmah Oil Company Ltd.

Occurrence

SEVERAL oilfields exist in Burma, those at present known and exploited being within a few miles of the Chindwin and Irrawaddy Rivers. On the latter river opposite Pagan there is a field at Yenangyat, farther down on the eastern side is the Singu field, still farther down and inland the Yenangyoung field, while on the opposite side, still lower down the river, are various small fields such as Yethaya and Palanyon. The most intensively developed and productive field so far is that of Yenangyoung, followed by Singu. The crude from these sources is of a mixed-base type rich in solid paraffins and light constituents. The following are characteristics of this general type of Burma crude.

Properties

Sp. gr. at 60° F.	0.835-0.842
Odour	Pleasant
Colour (solid)	Brownish green
" (liquid)	Brown by transmitted light; " green by reflected light
Setting-point	78-81° F.
Closed flash-point	Below 50° F.
Sulphur content	0.15%
Wax content	From 14.8% of m.p. 127° F. to 16.0% of m.p. 123° F.
Resins and asphalt	Below 3.0%
Naphthenic acids	Below 0.02%
Ash content	Below 0.0035%
Calorific value	10,900 cal. per g.: 19,630 B.Th.U. per lb.
Ultimate analysis:	
Carbon	86.45%
Hydrogen	13.25%
Nitrogen and sulphur	0.30%

Typical Sample

Vapour pressure (Reid method) at 100° F.	3.5-4.0 lb. per sq. in.
Kinematic viscosity at 80° F.	0.0388 c.g.s. units
" " 85° F.	0.0338 " "
" " 90° F.	0.0305 " "
" " 95° F.	0.0275 " "

Distillation Test: I.B.P. 64° C.

Below 100° C.	5.9%	5% distillate at 96° C.
100-150°	17.4%	112°
150-200°	10.5%	138°
200-225°	5.2%	180°
225-250°	6.6%	228°
250-285°	11.7%	263°
285-300°	5.0%	292°
Over 300°	37.5%	

Laboratory Distillation Analysis

This was carried out in a 10-gallon still fitted with a jacketed ring-packed column. The lighter fractions were distilled from the crude by fire only, then superheated steam introduced until approximately 60% of the crude has distilled over. The 40% residue distilled further under reduced pressure until a residue of approximately 4% was obtained. Table I (p. 892) shows some of the characteristics of fractions obtained by this method of analysis.

The setting-points recorded in the table were determined by the jar method for fractions setting below 100° F. and by the cooling-curve method for fractions setting above 100° F. The specific gravities of the fractions solid at 60° F. were taken when in the liquid condition and corrected to 60° F. by means of the N.P.A. tables. The fractions obtained in such an analysis as the above may be blended into gasoline, kerosine, gas oil, pressable wax distillate, slop wax distillate, and asphaltic residuum which may be refined to give products very similar to those obtained in actual practice.

Products

When average Burma crude is distilled in a modern distillation unit it gives fractions of which those shown in Table II (p. 893) are typical. Of these products the gasoline, whether at a minimum percentage, as shown, or at a maximum percentage, and the gas oils do not require any further treatment, being of pleasant odour and free from deleterious sulphur. The kerosine may be improved in burning quality by solvent extraction, and the residuum is suitable as a cracking stock. The pressable wax distillate may be readily separated into blue oil and paraffin scale by pressing. Owing to the high content of scale, filtration in a single stage of cooling is not practicable. The blue oil on distillation yields lubricating oils of various grades, while the paraffin scale on sweating yields waxes which require only a light finishing treatment by filtration through bauxite or other earth. The Tables III-VI (p. 893) show characteristics of some representative products.

SELECTED BIBLIOGRAPHY

The following abstracts cover the more important publications on the investigation of Burma crude and its products.

ALLIBONE, B. C. *Proc. World Petr. Cong.* 2, 725 (1933). Describes the colour reversion of kerosine fractions of Burma crude.

CARPENTER, J. A. *J.I.P.T.* 12, 518 (1926), and 14, 446 (1928). A comprehensive study of the composition of the fractions of Burma crude boiling up to 300° C., giving data on the aniline points, specific gravities, and refractive indices of the various classes of hydrocarbons isolated.

J.I.P.T. 12, 288 (1926). Describes the fractionation of wax from Burma crude by various methods, and gives data on the transition points, specific gravities, and expansion coefficients of these fractions.

ELOFF, G. *Oil and Gas J.* 29 (30), 46, 133 (1930). Describes the results obtained by cracking residuum from the distillation of Burma crude in a Dubbs unit and the refining of the pressure distillate so produced.

WILSON, W. J. *J.I.P.T.* 10, 227 (1924). Describes distillation analyses of Burma and Assam crudes, together with the system of fractional distillation and atmospheric condensation employed on the large scale and the type of sweating stove employed to process paraffin scale.

WILSON, W. J., and ALLIBONE, B. C. *J.I.P.T.* 11, 180 (1925). Describes experiments on the extraction of lubricating oils from Burma crude with acetone-sulphur dioxide.

TABLE I

Fraction	% by vol. of crude	Range of crude, % by vol.	Sp. gr. at 60° F.	Colour Lovibond 510Y/200R	Aniline point ° C.	Smoke- point	Setting- point ° F.	Absolute viscosity centipoises
1	7.87	0-7.87	0.702	..	50.2	0.360/20° C.
2	3.94	7.87-11.81	0.7585	..	39.6	0.539/20° C.
3	3.94	11.81-15.75	0.7635	..	41.1	0.569/20° C.
4	1.97	15.75-17.72	0.769	..	39.9	27	..	0.600/20° C.
5	1.91	17.72-19.63	0.776	..	40.2	24	..	0.632/20° C.
6	2.00	19.63-21.63	0.779	..	40.6	24	..	0.656/20° C.
7	2.00	21.63-23.63	0.782	..	42.0	23.5	..	0.696/20° C.
8	1.96	23.63-25.59	0.788	..	42.9	23	..	0.753/20° C.
9	2.00	25.59-27.59	0.792	..	43.0	22.5	..	0.802/20° C.
				(18 in.)				
10	1.91	27.59-29.50	0.795	..	46.8	22	..	0.918/20° C.
11	2.00	29.50-31.50	0.799	..	50.7	22	..	1.041/20° C.
12	1.95	31.50-33.45	0.808	2.3Y/0-2R	52.4	22	..	1.205/20° C.
13	1.97	33.45-35.42	0.814	2.5Y/0-3R	54.7	21.5	..	1.372/20° C.
14	1.96	35.42-37.38	0.819	2.7Y/0-3R	57.7	21	..	1.571/20° C.
15	1.96	37.38-39.34	0.825	3.9Y/0-7R	59.0	20	..	1.778/20° C.
16	2.04	39.34-41.38	0.831	3.9Y/0-6R	59.3	18.5	..	1.957/20° C.
17	1.90	41.38-43.28	0.837	5.5Y/1-2R	59.5	17	..	2.184/20° C.
18	2.08	43.28-45.36	0.843	8Y/1-6R	59.1	16	..	2.401/20° C.
19	1.96	45.36-47.32	0.848	13Y/3R	58.9	16	..	2.660/20° C.
20	2.05	47.32-49.37	0.854	45Y/4-5R	62.2	15	<0	3.496/20° C.
21	1.86	49.37-51.23	0.8545	45Y/4-5R	65.1	15	5	3.878/20° C.
22	1.98	51.23-53.21	0.8535	45Y/4-5R	67.4	15	10	4.244/20° C.
23	1.94	53.21-55.15	0.8545	50Y/4-5R	68.9	15	15	4.563/20° C.
24	1.84	55.15-56.99	0.8555	56Y/5R	69.1	15	19	4.849/20° C.
25	2.06	56.99-59.05	0.8535	56Y/6-4R	69.7	15	20	4.853/20° C.
				(2 in.)				
26	1.96	59.05-61.01	0.8645	15Y/1-4R	68.8	14	33	5.725/20° C.
27	1.94	61.01-62.95	0.868	20Y/1-4R	72.7	14	45	7.809/20° C.
28	1.98	62.95-64.93	0.8675	30Y/1-4R	75.3	14	51	9.147/20° C.
29	2.00	64.93-66.93	0.868	30Y/1-4R	78.4	14	59	10.470/20° C.
30	2.06	66.93-68.99	0.870	50Y/5R	80.2	14	65	12.210/20° C.
				(‡ in.)				
31	2.21	68.99-71.20	0.872	6Y/0-5R	82.6	13.5	72	5.293/50° C.
32	1.97	71.20-73.17	0.875	10Y/0-9R	83.2	13	78.5	6.019/50° C.
33	2.00	73.17-75.17	0.876	14Y/1R	85.8	..	84	6.714/50° C.
34	2.03	75.17-77.20	0.8775	17Y/1R	88.2	..	90	7.780/50° C.
35	1.99	77.20-79.19	0.879	27Y/1-2R	90.2	..	96	8.849/50° C.
36	2.04	79.19-81.23	0.8795	40Y/2-5R	93.0	..	102.7	10.560/50° C.
				(‡ in.)				
37	2.02	81.23-83.25	0.8805	25Y/1-2R	95.1	..	107.5	12.570/50° C.
38	2.07	83.25-85.32	0.8825	30Y/1-5R	97.4	..	112.8	10.720/60° C.
39	1.99	85.32-87.31	0.8855	45Y/2-7R	99.2	..	118.2	12.690/60° C.
40	2.05	87.31-89.36	0.889	45Y/2-2R	100.4	..	122.5	15.64/60° C.
41	2.08	89.36-91.44	0.8975	50Y/4-5R	100.7	..	126.3	21.35/60° C.
				(‡ in.)				
42	2.12	91.44-93.56	0.9115	47Y/4-2R	100.3	..	129.6	34.30/60° C.
43	0.81	93.56-94.37	0.924	50Y/12R	98.5	..	132.1	52.95/60° C.
Residue	4.03	94.37-98.40	0.973	138	..
Loss	1.60	98.40-100.0	(R.-B.)	..

TABLE II

	Gasoline	Kerosine	Gas oil A	Gas oil B	Pressable wax dist.	Residuum
Per cent. by volume	18.4	32.4	12.3	3.3	27.2	6.4
Sp. gr. at 60° F.	0.7355	0.818	0.8565	0.869	0.883	0.965
Colour, Lovibond	< 1Y (18 in.)	< 1Y (18 in.)	0.6Y (1 in.)	0.7Y (1 in.)	9Y (1 in.)	..
I.B.P., ° C.	47	146	261
F.B.P., ° C.	147	267
Flash-point, ° F.	..	92	245	245	355	480
Cloud-point ° F.	34	32
Setting-point, ° F.	105	125

TABLE III

	Gasoline		Kerosine
	Aviation (blended)	Motor (blended)	
Sp. gr. at 60° F.	0.7545	0.7275	0.8085
Colour, Lovibond	< 0.5Y (18 in.)	< 0.5Y (18 in.)	< 0.5Y (18 in.)
Sulphur content	0.02%	0.03%	0.03%
Aromatic content, % by weight	31	12	17
Vapour pressure at 100° F. (Reid)	5.7	7.8	..
Octane no. (C.F.R.)	77.5	69	..
Closed flash-point	85° F.
Abs. viscosity/25° C.	1.22 c.p.
Cloud-point	< 12° F.
Smoke-point	20.5
I.B.P.	49° C.	44° C.	139° C.
10% distillate at.	67°	64.5°	155.5°
20% "	75.5°	73.5°	165.5°
30% "	83.5°	81.5°	178°
40% "	91°	87.5°	190°
50% "	98°	92°	204.5°
60% "	108°	99°	220°
70% "	118.5°	105°	236.5°
80% "	131°	115°	251.5°
90% "	143.5°	135°	268.5°
F.B.P.	161°	188°	291°
Total distillate	98%	97.5%	98.5%

TABLE IV

	Jute batching oil	Diesel oil	
		A grade	B grade
Sp. gr. at 60° F.	0.9155	0.865	0.883
Colour, Lovibond	9Y/1R (1 in.)	0.6Y (1 in.)	32Y/4.5R (1 in.)
Closed flash-point, ° F.	325	255	285
Setting-point, ° F.	40	30	35
Redwood viscosity at 100° F., sec.	98	38	46.5
I.B.P.	300° C.	262° C.	270° C.
10% distillate at.	329°	279°	297°
20% "	343°	284°	305°
30% "	354°	288.5°	311°
40% "	363°	292°	317°
50% "	373°	296°	323°
60% "	382°	299.5°	330°
70% "	390°	304°	338°
80% "	398°	310.5°	348°
90% "	..	322°	366°
F.B.P.	..	351°	..
Total distillate	..	98.5%	..

TABLE V

Paraffin wax grades	140-5	135-40	130-5	125-30	Match wax
Setting-point, ° F.	140.25	136.0	131.5	127.0	110.0
Colour, Lovibond (18 in.)	0.5Y	0.5Y	0.5Y	0.5Y	4.0Y

TABLE VI

Product	Spindle oil	Lubricating oils		
		Light motor oil	Medium motor oil	Heavy motor oil
Sp. gr. at 60° F.	0.919	0.907	0.919	0.920
Colour, Lovibond (1 in.)	9Y/1R	26Y/3R	24Y/3R	30Y/4R
Closed flash-point, ° F.	320	385	425	455
Open flash-point, ° F.	350	405	455	475
Setting-point, ° F.	20	20	24	21
Conradson coke value	0.02	0.33	0.18	0.37
Acidity value, mg. KOH	0.007	0.03	0.03	0.016
Saponification value, mg. KOH	0.19	0.17	0.23	0.19
Redwood no. 1 viscosity at 70° F., sec.	279	1,015	1,826	..
100° F. "	117	353	554	843
140° F. "	57.5	123	164	234
180° F. "	43.5	65.5	77.5	99
200° F. "	39	54	61	73

IRAN

By F. B. THOLE, D.Sc., M. Inst. P.T.

Anglo Iranian Oil Company, Ltd.

The principal oilfields of Iran may be divided geographically into three groups:

- The Masjid-i-Suleiman and Haft Kel fields north of Ahwaz.
- The Naft-i-Shah field near Khaniquin.
- The Bahrain field on Bahrain Island in the Persian Gulf.

There are in addition a large number of oil seepages as well as accumulations of unknown magnitude.

The general chemical nature of the oil does not vary greatly throughout the country. The oils from Masjid-i-Suleiman and Haft Kel are almost identical, and that from Naft-i-Shah differs but little from these. These fields are controlled by the Anglo-Iranian Oil Company, and the data given below are taken from this company's records.

The Bahrain field is controlled by the Standard Oil Company of California, and the nature of this crude is dealt with elsewhere.

The Iranian oils from the Masjid-i-Suleiman, Haft Kel, and Naft-i-Shah areas are mixed-base oils predominantly paraffinic. They contain some asphalt and sulphur and are associated in the field with large volumes of gas held in solution under high pressures which range from 1,500 lb. downwards. When the crude oil issuing from the wellhead at high pressure is released into the gas separators, a large proportion of this gas rapidly separates from the oil. This gas contains a considerable proportion of hydrogen sulphide, the remainder consisting entirely of paraffin hydrocarbons; the composition of the gas will naturally depend to a considerable extent on the temperature and pressure at which the gas separators are operated, as well as on whether single-stage or multi-stage reduction of pressure is employed. If single-flash separation is employed, the number of volumes of gas per volume of oil obtainable are as follows, the temperature of separation being indicated in brackets:

Masjid-i-Suleiman	42 vols. (68° F.)
Haft Kel	91 " (76° F.)
Naft-i-Shah	179 " (80° F.)

An analysis of the first of these gases indicates the following composition:

H ₂ S	10.4% by vol.
CH ₄	45.3% "
C ₂ H ₆	13.5% "
C ₃ H ₈	15.3% "
C ₄ H ₁₀	10.8% "
C ₅ H ₁₂ and heavier	4.7% "

Olefines, nitrogen, and carbon dioxide are absent. Helium is present in very small amount— 2.5×10^{-8} litres per litre of gas, or about 5 times the concentration in atmospheric air.

The separated crude oil still retains some of these gases in solution, so that further quantities are released on distillation of the oil. The butane and pentanes in these gases are, of course, recoverable as natural gasoline by conventional processes of compression and stabilization.

The following analytical data refer to Iranian crude oil

from Masjid-i-Suleiman and Haft Kel (col. 1) and Naft-i-Shah (col. 2).

	M.-i-S. and H. K.	N.-i-S.
Specific gravity	0.836	0.810
Water	nil	nil
Sulphur	1.0%	0.76%
Viscosity, 60° F., centistokes	5.0	5.0
Distillation from 100-ml. flask:		
to 50° C.	1%	2.5%
" 75° C.	4%	3.5%
" 100° C.	9%	8%
" 125° C.	16%	15.5%
" 150° C.	22%	24.0%
" 175° C.	27.5%	32.5%
" 200° C.	33.5%	38.5%
" 225° C.	39.7%	44%
" 250° C.	44.5%	51%
" 275° C.	50.8%	55.5%
" 300° C.	56%	61.5%

It will be seen from these figures that approximately 30% of gasoline and 15% of kerosine may be obtained from these oils by direct distillation. By continuing the distillation under reduced pressure further products representing gas oil (about 15%), lubricating oil base and wax (about 35%), and residual asphaltic bitumen (about 5%) are obtained. The actual proportions are, of course, variable over wide limits according to the various specifications which the products may be designed to meet.

The gasoline contains about 10% of aromatic hydrocarbons (2% benzene, 3% toluene, and 5% xylene and higher aromatics) and the kerosine about 17% of such hydrocarbons. These may be extracted by appropriate selective solvents such as liquid SO₂ or completely removed by sulphonation.

The gasoline and kerosine also contain small amounts of alkyl mercaptans and alkyl sulphides, the presence of which necessitates refining treatment before these products can be marketed.

Oxygen and nitrogen compounds are entirely absent from these distillates.

The essentially paraffinic nature of Iranian crude oil is illustrated by the low octane value of the gasoline (about 52) and the high cetane value of the gas oil. Careful fractional distillation of the gasoline gives a curve showing maxima corresponding with all the normal paraffin hydrocarbons together with minor peaks corresponding with some of the isomeric paraffins and with the aromatic hydrocarbons present.

The lubricating oil portion of the distillate, which lies in the 60-95% fraction of the crude oil, is semi-solid with paraffin wax. After removal of the latter by conventional processes a lubricating oil base is obtained which by re-distillation may be divided into products ranging from light spindle oil to heavy cylinder stock. Light refining treatment with acid and clay gives oils of good colour and stability and with a viscosity index of the order of 60-70. Heavier acid treatment or the application of selective solvent refining processes increases this viscosity index of the products to the order of 90, 100, or even over 100 according to the degree of treatment given.

BAHREIN ISLANDS

By G. EGLOFF, M.A., Ph.D.

Universal Oil Products Company

The crude oil produced on the Bahrain Islands is a mixed base oil, produced at depths ranging from 1,850 to 2,500 ft. The crude contains about 30% of 400° F. end-point gasoline of 42 octane rating.

A refinery with a daily crude charging capacity of 25,000 bbl. a day is now being built. It will include a Dubbs unit to crack 10,500 bbl. a day of topped crude and a 6,000-bbl. a day reforming unit. See below.

Fractions removed:	None	Hempel distillation						Topped crude (after removal of 299° F. gasoline)	Topped crude (after removal of 350° F. gasoline)	Topped crude (after removal of 401° F. gasoline)	Reduced crude (after removal of gasoline and kerosine)
		242° F. gasoline	299° F. gasoline	350° F. gasoline	400° F. gasoline	240-360° F. naphtha	360-525° F. kerosine				
Yields, vol. % of crude	100.0	9.7	16.5	22.7	29.6	13.5	17.4	83.3	77.1	70.2	59.1
<i>Properties of fractions</i>											
Gravity, °API.	31.9	81.7	74.5	68.0	62.7	58.4	44.5	25.7	24.1	22.0	18.9
Sp. gr. at 60° F.	0.8660	0.6637	0.6869	0.7093	0.7286	0.7451	0.8040	0.9001	0.9094	0.9218	0.9408
Sulphur, %	2.0	0.015	0.02	0.02	0.03	0.03	2.74	3.22
Octane number (C.F.R. Motor Method)	..	64	55	48	42	36
Flash-point (Cleveland Open Cup), °F.	230	275
Flash-point (Pensky-Martens), °F.	226	568
Viscosity (Universal), sec. at 100° F.
Viscosity (Universal), sec. at 122° F.
Viscosity (Furcl), sec. at 77° F.
Viscosity (Furcl), sec. at 122° F.	19	315
B.S. & W., %	0.2	0.1	0.1
Cold test, °F.	below 0	15	20
<i>Engler distillation</i>											
Initial b.p.	° F.	° F.	° F.	° F.	° F.	° F.	° F.	° F.	° F.	° F.	° F.
% distilled over	131	80	89	96	105	193	359	321	379	443	538
5	204	92	114	126	137	224	374	360	419	482	566
10	252	102	126	142	158	233	382	388	440	508	591
20	338	116	145	169	191	245	392	456	502	558	633
30	429	128	162	192	220	255	401	534	572	611	660
50	618	151	192	232	271	275	421	658	676	682	689
70	712	178	220	267	313	296	446	691	706	705	712
80	747	216	257	308	362	329	486	730	735
90	780	242	299	350	401	361	525	730	735	735	735
End point	748	242	299	350	401	361	525	730	735	735	735
Total % over	94.0	96.0	97.0	97.5	98.0	99.0	99.0	93.5	93.0	92.5	91.5
% bottoms	..	1.0	1.0	1.0	1.0	1.0	1.0
% coke by weight	..	5.1	6.4	6.9	7.4	8.5
% loss	3.0	2.0	1.5	1.0
% at 400° F.	..	27.5	29.0	12.0	2.5
% at 572° F.	..	45.5	35.5	30.0	23.0	6.0

IRAQ

By M. S. MAINLAND, B.Sc., A.I.C., A.M.I.Chem.E.

Acting Production Superintendent, Iraq Petroleum Company, Ltd.

PRODUCTION of oil on a commercial scale in Iraq was initiated on 14 October, 1927, when, after an intensive exploration and drilling campaign, the Iraq Petroleum Company brought in No. 1 Well Baba Gurgur of the now famous Kirkuk field. This crude oil became available on the world market in 1934, upon completion of the Iraq pipeline to the Mediterranean seaboard. Production is drawn exclusively from the Kirkuk field, which furnishes a uniform crude from over an extensive area. Control of the field by a single operating company allows its efficient exploitation as a unit, the production methods used ensuring maximum conservation of the energy of the reservoir. This latter consists of a highly porous limestone which permits great freedom of oil movement and provides wells capable of very large rates of flow. All wells flow under natural reservoir pressure, and no free gas is anywhere produced in the formation.

In appearance Kirkuk crude oil is reddish-brown, without bloom, transparent only in thin section. Chemically it is a mixed-base crude containing both paraffinic and naphthenic hydrocarbons, with the former predominating; the oil is very poor in aromatics. As produced it contains no free water or sediment; dissolved water does not exceed 0.004% while chloride content is less than 0.001% by weight. The following table gives the characteristics of the crude as determined by I.P.T. standard methods.

Specific gravity 60°/60° F.	0.844
B.S. and W.	negligible
Flash-point	below 0° F.
Fire-point	below 0° F.
Hard asphalt	0.9% weight
Viscosity Redwood No. 1:	
at 40° F.	59 sec.
at 70° F.	44.5 sec.
at 100° F.	38.5 "
Sulphur content	2.01% weight
Wax content	1.95% "
Pour-point	Below 0° F.
Standard distillation:	
Initial boiling-point	46° C.
Distilling to 50° C.	trace
" 75° C.	2% volume
" 100° C.	8% "
" 125° C.	14.5% "
" 150° C.	22.5% "
" 175° C.	29% "
" 200° C.	34.5% "
" 225° C.	39.5% "
" 250° C.	45% "
" 275° C.	50% "
" 300° C.	57% "
Specific gravity 60°/60° F.:	
of distillate	0.771
of residue	0.946
Residue	42.5% volume
Loss	0.5%

These figures show that the crude is of low specific gravity and low viscosity, and is mobile down to very low temperatures. It is a sour crude, as indicated by the high sulphur content, and the products it yields on distillation, owing to their corrosive nature, require intensive refining to meet market specifications. Despite the presence of free

hydrogen sulphide, in the absence of water, the crude only acquires actively corrosive properties from exposure to, and absorption of, air. The crude contains a high-melting wax fraction (165-170° F. melting-range), which is in saturated solution at a temperature of about 95° F. Below this temperature, this wax commences to crystallize out of solution and tends to deposit upon standing in tankage as a thick sludge, carrying down with it varying amounts of asphaltic and resinous compounds. Settlement of sludge in tank-ships in course of conveyance from pipeline terminal stations to refineries has occasioned some difficulty: with exposure of crude in ship's tanks to low sea temperatures, sludge is thrown down which is too thick to pump ashore, and subsequent tank cleaning is arduous.

From the refiner's viewpoint, the chemical composition of Iraq crude oil offers a very wide range of commercial products, from the low-boiling hydrocarbons to paraffin wax and asphalts. Owing to the sourness of the crude, however, the products require a severe refining treatment to become commercially acceptable.

The characteristics of products typical of those obtained at a refinery operating on Iraq crude are shown hereunder. In this case, treatment in a light topping and stabilizing unit is followed by atmospheric distillation giving gasoline and different grades as overhead, with kerosine, gas-oil, and wax distillate side-streams.

Typical examples are as follows:

From the primary topping and stabilizing unit,

	Very light stabilized gasoline
% by weight on crude	8
Specific gravity 60°/60° F.	0.677
Initial boiling-point	21° C.
10% distilling at	40° C.
20% "	50° C.
50% "	80° C.
90% "	165° C.
Final boiling-point	183° C.

From atmospheric distillation alternative processes will give

Alternative Products	1			2	
	Light gasoline	Kerosine	Gas oil	Heavy gasoline	Gas oil
% by weight on crude	18.5	19.5	17.5	27	28
Specific gravity	0.740	0.806	0.845	J-755	0.842
60°/60° F.	57° C.	187° C.	200° C.	50° C.	217° C.
Initial boiling-point	92	205	270	95	252
10% distilling at	133	225	303	152	287
50% "	165	253	342	203	333
90% "	175	273	360	215	360
Final boiling-point					

All gasoline distillates contain sulphur in elemental form, as well as hydrogen sulphide and mercaptans. Consequently soda washing followed by doctor treatment is the usual practice for sweetening; the sulphur content of gasolines may first be reduced by acid treatment.

Straight-run gasolines are all very low in aromatic content and possess an octane rating of less than 50; for commercial purposes this property of the straight-run products

is improved by reforming, blending with cracked spirit, or by the addition of tetra ethyl lead.

A satisfactory kerosine is obtained from the raw kerosine by solvent refining with liquid-sulphur dioxide in an Edeleanu plant.

Gas oil from Iraq crude constitutes an excellent Diesel fuel; it possesses very satisfactory viscosity and pour-point characteristics.

Satisfactory lubricating oil is obtainable only by suitable solvent extraction processes.

Wax distillate yields commercial grades of paraffin wax by the usual methods, together with a filtrate oil suitable for Diesel fuel or as a flux in making road oils.

A 33% residue is left which may be subjected to vacuum distillation to give residual asphalts. The heavy distillate

from this operation is employed as cracking stock, as well as other lighter distillates, according to market demands. Reduced crude, or fuel oil residuum, may also be used as cracking stock, yielding approximately 40% of gasoline having an octane rating of 65 to 70.

An alternative treatment of the crude yields a residual fuel oil of the following characteristics.

Per cent. by volume on crude	71.2
Specific gravity at 60°/60° F.	0.899
Viscosity Redwood No. 1:	
at 60° F.	252 sec.
at 100° F.	90 "
Sulphur content	2.44% weight
Hard asphalt	2.9% "
Cold test	below 0° F.
Calorific value	19,200 B.Th.U. per lb.

EGYPT

By R. J. FORBES, M.N.R.I.E.

Chemical Engineer, Amsterdam Laboratory, Bataafsche Petroleum Maatschappij

In many handbooks it is stated that the oil and natural asphalt occurring in Egypt were already used by the ancient Egyptians. Nothing is less true. The only thing we know for certain is that in the last period of ancient Egyptian history asphalt was used for the first time for mummification, not as a mortar. Neither was crude oil used for illumination. The use of bitumen developed in the Hellenistic era; it was imported from the Dead Sea. The Romans knew various seepages on the coast of the Red Sea (thus, they called Gebel Zeit Mons Petrolius), but their exploitation was never taken in hand [4, 1936]. These outcrops were discovered once more in the latter half of the last century. In 1884 the first well was drilled at Gernsah; in 1914 the exploitation of Hurghada was started; while in 1921 Abu Durba was discovered. This field was, however, already exhausted in 1929, and Gernsah, too, has not produced more than 3,000 tons since that year, so that the entire present production may be said to be supplied by Hurghada. The total production was at its zenith in 1929 with 318,000 tons, but it has since dropped to 256,000 tons in 1932, so that Egypt now produces less than 0.1% of the world production. This amount does not enable Egypt to produce all the petroleum products necessary for her own consumption, so that most special products, such as lubricating oils, paraffin wax, &c., have to be imported. According to Dewhurst [2, 1934] the oil reserve, as far as can be deduced from the present geological evidence, is no more than 10,000,000 bbl. The oil produced in the three fields differs considerably in nature, as will appear from Table I.

TABLE I

	Abu Durba [5]	Gernsah [5]	Hurghada [5]
Sp. gr./15° C.	0.945-0.960	0.827	0.907-0.925
Visc. Red. no. 1/100° F.	c. 3,000 sec.		c. 400 sec.
Sulphur, % wt.	2.35%	0.65%	2.2-5%
Asphalt, % insol. in pentane	10.5%	0.63%	10-11%
Paraffin wax, %	4.94%	7-8%
% gasoline	20%	27%	8.0%
% kerosine		32.4%	15.0%

The now exhausted field of *Abu Durba* is about 100 miles south of Suez on the west coast of the Sinai Peninsula. The oil produced there from limestone and shale formations has, owing to its high bitumen content and the absence of paraffin wax, all the characteristics of a pronounced asphaltic crude.

Across the Red Sea, on a peninsula 150 miles from Suez, is *Gernsah*. This pool has, so far, yielded about 210,000 tons in all of a typical waxy crude, with a fairly high content of low-boiling constituents. The producing formation is probably a Middle Miocene limestone, at a depth of 1,290 ft. During distillation a fairly large amount of dissolved hydrogen sulphide gas is liberated, though the refining of the lighter fractions does not seem to present any special difficulties. The lower boiling constituents contain about 25% of aromatics, the remainder, and also the residue,

largely consist of naphthenes, according to Engler, so that this oil shows a great resemblance to the waxy crude from Baku. The lubricating-oil product from this crude is on a par with the Pennsylvanian and Russian.

The most important field, of *Hurghada*, is also on the west coast of the Red Sea, 180 miles south of Suez. The first well was completed in 1914, and the yield of this pool was soon sufficient to compensate for the sinking production of the other fields. The producing formations are Cretaceous sands and shales at a depth of 1,600-2,000 ft. This oil forms the bulk of the intake by the refinery of the Anglo-Egyptian Oilfields Ltd. at Suez, which is, in fact, the only important producer in Egypt.

TABLE II

Crude Oil from Egypt (Hurghada)

Sp. gr. at 15°/4° C.	0.900
Sulphur content	2.8%
Pour-point	< 0° C.
Viscosity E°/40° C.	4.0
<i>Yields:</i>	
Gasoline, % age by weight	12.5%
Kerosene, " " "	7.5%
Gas-oil, " " "	16.0%
Residue (including loss)	64.0%
	100.0%
<i>Gasoline:</i>	
Sp. gr. at 15°/4° C.	0.722
Sulphur content	0.08%
Initial boiling-point	35° C.
10%	64° C.
50%	110° C.
90%	155° C.
Final boiling-point	178° C.
<i>Kerosene:</i>	
Sp. gr. at 15°/4° C.	0.808
Sulphur content	0.15%
Initial boiling-point	170° C.
10%	190° C.
50%	220° C.
90%	250° C.
Final boiling-point	275° C.
<i>Gas-oil:</i>	
Sp. gr. at 15°/4° C.	0.850
Viscosity Red. no. 1/100° F.	35 sec.
Sulphur content	1.3%
Pour-point	25° F.
<i>Residue:</i>	
Sp. gr. at 15°/4° C.	0.960
Viscosity Red. no. 1/100° F.	170 sec.
Pour-point	90° F.
Carbon residue (Conradson)	7.5%

From the figures in Table II it follows that this crude is a typical mixed base crude with a high paraffin wax and bitumen content. It must therefore be considered impossible to win wax from it by the present methods, although Guthrie [5, 1923] proved experimentally that by light cracking a 6% scale can be separated from this oil. For

the present the refining merely consists in topping and, occasionally, in the preparation of special asphaltic bitumens, much residue being cracked as well [3, 1931; 6, 1927-8]. Unlike the Gemsah crude, this oil contains no

appreciable quantities of hydrogen sulphide, and the light fractions are also easy to refine and contain little sulphur. The crude often contains up to 30% of emulsified calcareous salt-water.

REFERENCES

1. BOLANI, E. *Erdol u. Teer*, no. 13, 158 (1934)
2. DEWHURST, T. *J.I.P.T.* 20, 281 (1934).
3. EGLOFF, E., NELSON, E. F., and TRUESDELL, P. *Oil and Gas J.* 30, (12) 22 (1931).
4. FORBES, R. J. *Bitumen and Petroleum in Antiquity* (Brill, Leiden, 1936).
5. GUTHRIE, W. A. *J.I.P.T.* 9, 212-34 (1923).
6. MCCONNELL-SANDERS, J. *J.I.P.T.* 12, 672 (1927-8).
7. MISRAHI, N. *Mon. Pétr. Roum.* 35, 427-31 (1934).
8. SELL, G. *J.I.P.T.* 19, 673 (1933).

U.S.S.R.

By A. VELIKOVSKY

Chief of the Oil Research Laboratory of the State Oil Research Institute

THE U.S.S.R. takes second place in the world in the production of oil, following the U.S.A.

At the present time the oil regions from which most of the oil is obtained are situated in the Caucasus. In it are the following regions: Baku (Apsheon) in the South Caucasus, Daghestan, Grozny, and Maikop (Kuban-Black Sea) in the North Caucasus. Moreover, oil is found in considerable quantities in Georgia, near Tiflis, and a whole series of other districts of the Caucasus, as is shown on the

Besides this, oil has been discovered in a large number of points in the U.S.S.R., as is shown on the accompanying map (Fig. 1).

Apsheon Region

The Apsheon region is the most prolific oil area in the U.S.S.R. It is situated on the Apsheon Peninsula on the mainland nearby, by the Caspian Sea, and on the island of Artem.

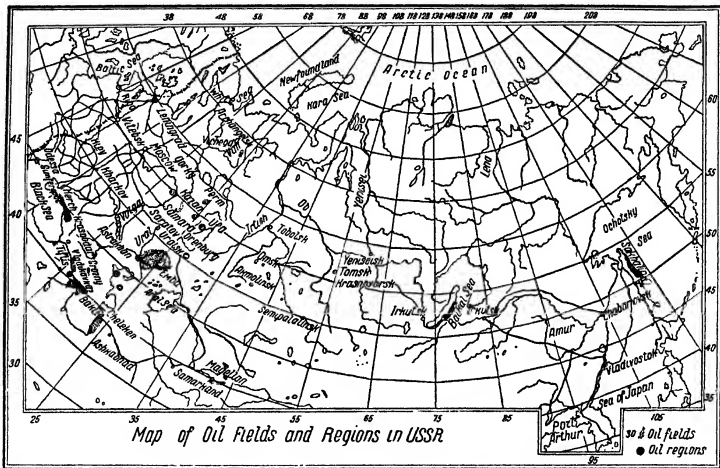

FIG. 1.

accompanying map. There is also oil in the Crimea, near Kerch. This field is considered as part of the Maikop (Kuban-Black Sea) region, situated in the Caucasus on the other side of the Straits of Kerch.

The Emba region is situated near the north-eastern part of the Caspian Sea, and covers an area of about 38,000 square miles. Farther north, near Ufa, is located the Sterlitamak field, while still farther north, near Perm, is the Chusovski field, and finally in the basin of the Pechora River is situated the Uchta field. There are two oil regions in Central Asia: the Turkmenian, situated along the southern part of the eastern shore of the Caspian Sea, and the Fergana, near the City of Kokand. Finally, a number of oilfields are found on the island of Sakhalin, mostly along the eastern shore.

The most important fields in this region are, counting from east to west: Artem, Kali, Surakhany, Balakhany-Romany-Sabunchi, Binagady, Bibi-Eibat, Lok-Batan, and Puta.

Despite the fact that the Apsheon oils are obtained from a comparatively small area, they differ markedly in quality. Among the oils of these regions are oils having both a pronounced asphaltic and paraffinic base. In the same field, oils change markedly with the depth of the bed.

Oils of the following fields are especially distinguished by their pronounced asphaltic base: the island of Artem, Binagady, part of Balakhany, and the deep strata of the Bibi-Eibat and Lok-Batan fields. The upper strata oils of

the Surakhani and Kara-Chukhur fields are distinguished by their paraffin base. In the deeper strata of these fields, there exists heavier oil.

The other oils, as for example, Balakhany from the top strata, Bibi-Eibat from the top strata, Lok-Batan from the top strata, and Kala are an average between the two mentioned types and may be considered as paraffin-base oils.

Despite the large differences between oils from the various fields in the Apshehon region, there are some properties common to all. Thus, all the oils of this region contain a comparatively small quantity of sulphur, usually not exceeding 0.3%, and only in Artem oil does it reach 0.5%.

All oils contain a comparatively small quantity of the fraction boiling to 100° C., and for this reason from all Apshehon oils there is usually taken gasoline for automobile and aviation engines having an end point of 130-170° C. and heavy naphtha—not including the light gasoline fractions—for tractor engines. Frequently all of the heavy naphtha is left in the kerosine.

The chemical composition of the light fractions which, without relationship to the other properties of the oil, are very close for all Apshehon oils, is the most remarkable general property of the oils of this region.

The characteristic chemical composition of gasoline fractions of a series of oils from the Apshehon Peninsula, calculated according to the data of A. N. Sakhanen and R. A. Virobyanz, is given in Table I.

TABLE I

Gasoline obtained from	Distillation range from initial point to	Hydrocarbons		
		Aromatics %	Naphthenes %	Paraffins %
Surakhany paraffinic	200° C.	8.6	64.4	27.0
Balakhany light	200° C.	6.4	68.6	25.0
Bibi-Eibat light	200° C.	8.0	61.0	29.0
Binagady	200° C.	12.5	64.4	23.1

From this data it is seen that the gasoline fractions from crude oils of widely differing properties possess approximately the same composition—a relatively low content of aromatic hydrocarbons (6.4-12.5%), considerable paraffins (23-29%), and a high percentage of naphthenes (63-8%).

Gasolines, distilled to a lower end point, contain considerably less aromatic hydrocarbons, as may be seen from the following data of M. Wolf, Table II.

TABLE II

Gasoline obtained from following oils	Distillation range from initial point to, ° C.	Hydrocarbons		
		Aromatics %	Naphthenes %	Paraffins %
Surakhany paraffinic	125	0.7	71.0	28.0
"	150	1.4	70.0	28.0
Bibi-Eibat light	125	2.2	55.0	43.0
"	150	2.7	56.0	41.0
Bibi-Eibat heavy	125	0.4	52.0	48.0
"	150	0.8	55.0	44.0
Binagady	125	2.3	51.0	46.0
"	150	3.2	53.0	43.0

It might be assumed, at first glance, that straight-run gasoline from Apshehon region oils would have a very low octane number on account of their relatively low content of aromatics and large amount of paraffins. Actually, however, they have a very high octane number, even including

gasoline from Surakhany oil which in its higher fractions has a pronounced paraffinic base. The octane numbers for gasolines from three Apshehon oils are given in Table III. All octane numbers in this and following tables were determined by the C.F.R. motor method.

TABLE III

No.	From which oil	Specific gravity at 15° C.	Distillation according to American standard, ° C.				End point	Octane number
			Initial boiling-point	10%	50%	90%		
1	Surakhany	0.747	72	85	97	116	138	80
2	"	0.793	119	202	60
3	Bibi-Eibat	0.748	70	90	108	127	145	71
4	"	0.759	73	99	121	145	163	69
5	"	0.764	75	103	128	151	164	68
6	Balakhany	0.744	71	83	93	107	136	82
7	"	0.757	83	96	109	131	154	78
8	"	0.772	91	107	125	161	175	72
9	"	0.781	93	120	143	179	191	68

From this data it follows that gasolines from all of the investigated Baku oils possess a considerably higher octane number than many straight-run spirits. This may be explained by the fact that most of the paraffin hydrocarbons in the gasoline fractions from Baku oils have an *iso*-structure, as may be seen from the following data of the detailed chemical composition of a gasoline from a mixture of Baku oils, calculated on the fraction to 150° C., as shown in Table IV.

TABLE IV

No.	Name of the hydrocarbon	Percentage composition, calculated on the fraction to 150° C.
1	<i>iso</i> -Pentane	0.5
2	<i>n</i> -Pentane	1-6
3	Cyclo-pentane	0.2
4	<i>iso</i> -Hexane	1-0
5	<i>n</i> -Hexane	3-0
6	Methyl cyclo-pentane	2-6
7	Cyclo-hexane	7-0
8	Benzene	0-2
9	<i>iso</i> -Heptane	6-1
10	<i>n</i> -Heptane	3-0
11	Hepta-naphthenes	19-3
12	Toluene	1-0
13	<i>iso</i> -Octane	9-6
14	Octo-naphthenes	15-5
15	<i>n</i> -Octane	5-6
16	Xylenes	2-1
17	Nono-naphthenes	13-3
18	<i>iso</i> -Nonane	4-4
19	<i>n</i> -Nonane	3-0

As a rule, Baku paraffin base gasolines show higher octane numbers than asphaltic base gasolines. Thus, a Binagady asphaltic base gasoline, 30% of which distills below 100° C., has an octane number of 65; while a Surakhany paraffin base gasoline of similar boiling range has an octane number of 72. On the other hand, the figures quoted show that the difference in the octane numbers of the various Baku gasolines is not great, and that all of them must be considered as possessing high octane values.

As opposed to gasolines, Baku asphaltic base kerosines show considerably higher octane numbers than similar fractions of paraffin base oils. This is explained by the fact that Baku asphaltic base kerosines contain a high percentage of aromatic hydrocarbons and are low in aliphatics, while paraffin base kerosines show the opposite

relationship between aromatic and aliphatic hydrocarbons (compare the chemical structure of Surakhany and Binagady kerosines in Table V).

The kerosine fractions of Apsheon oils, distilling in the range 200–300° C., are considerably richer in aromatic hydrocarbons than the gasolines, as may be seen from the following figures.

TABLE V

Kerosine obtained from following oils	Boiling range, °C.	Hydrocarbons			
		Aromatic %	Naphthenes %	Paraffins %	Unsaturated %
Surakhany paraffinic	200-300	17	41	42	..
Balakhany light	"	17	68	15	..
Bibi-Eibat heavy	"	24	48	28	..
Binagady	"	32	60	7	1

The octane numbers of kerosines from several Baku crudes are given in Table VI.

TABLE VI

Crude	Distillation range			Octane number
	Initial boiling-point, °C.	% at 200° C.	End point, °C.	
Heavy Balakhany	166	12	293	45.5
Binagady	136	10	300	46.0
Light Bibi-Eibat	172	10	293	36.0
Surakhany paraffin base	178	10	293	29.0
Kara-Chukhur	176	6	296	14.5

Baku asphaltic base kerosines are good tractor fuels. Paraffin base kerosines are good illuminants, as they are high in aliphatic hydrocarbons.

Apsheon residues after the removal of benzene and kerosine fractions show a considerable difference among themselves. For example, the specific gravity of the residue after distilling off fractions to 300° C. fluctuates from

in aromatic hydrocarbon content. They also vary in regard to the number of rings in the naphthenic hydrocarbons, which for the fraction 500–550° ranges from 1 to 3 (according to Vlугter). Unfortunately, there is no data for the chemical composition of the lubricating oil fractions from the heavier Apsheon oils. However, it may be pointed out

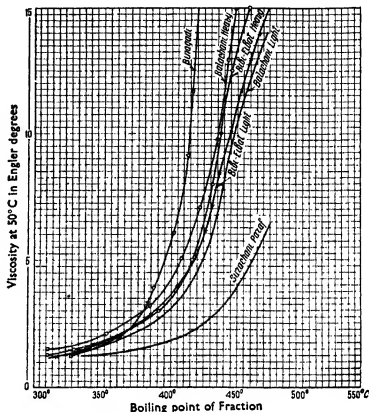

FIG. 2.

that the oil fractions of Balakhany heavy crude contain more than 40% aromatic hydrocarbons. The properties of lubricating-oil fractions from various Apsheon oils (including

TABLE VII

Oil	Viscosity		Specific gravity at 15° C.		n _D ²⁰		Maximum, aniline point, °C.		Hydrocarbon content				
	Boiling range °C.	Before removal of aromatics, Engler at 50°	After removal of aromatics, Engler at 50°	Before separating aromatic hydrocarbons	After separating aromatic hydrocarbons	Before separating aromatic hydrocarbons	After separating aromatic hydrocarbons	Before separating aromatic hydrocarbons	After separating aromatic hydrocarbons	Aromatics %	Naphthenes %	Paraffins %	Average series
		Before separating aromatic hydrocarbons	After separating aromatic hydrocarbons	Before separating aromatic hydrocarbons	After separating aromatic hydrocarbons	Before separating aromatic hydrocarbons	After separating aromatic hydrocarbons						
		Before separating aromatic hydrocarbons	After separating aromatic hydrocarbons	Before separating aromatic hydrocarbons	After separating aromatic hydrocarbons	Before separating aromatic hydrocarbons	After separating aromatic hydrocarbons						
Surakhany paraffinic	350-400	1.30	1.28	0.850	0.833	1.4709	1.4603	85.8	91.0	16	63	21	C ₁₅ H ₃₂
"	500-550	5.00	4.10	0.890	0.877	1.4778	1.4722	106.6	109.0	10	78	12*	C ₁₈ H ₃₆₋₄₁
Balakhany light	350-400	1.36	1.36	0.881	0.854	1.4852	1.4699	76.2	87.8	22	76	..	C ₁₅ H ₃₀₋₃₃
"	500-550	13.0	6.5	0.920	0.895	1.5074	1.4889	99.6	109.6	22	76	..	C ₁₈ H ₃₄
Bibi-Eibat light	300-400	1.32	1.32	0.888	0.857	1.4930	1.4701	72.0	85.5	27	72	..	C ₁₅ H ₃₀₋₃₂
"	500-550	11.32	5.04	0.928	0.892	1.5137	1.4879	94.6	106.0	26	73	..	C ₁₈ H ₃₄₋₃₈

* Melting-point 59.5° C.

0.874 to 0.952; the viscosity from 3.5 Engler at 50° C. to 2.3 Engler at 100° C.; the content of 'resinous substances' from 10 to 44%; and pour-point from less than -20° C. to +33° C.

Table VII gives data for the chemical composition of oil fractions from some Apsheon oils, distilled in a vacuum in the ranges 350–400° C. and 500–550° C., recalculated temperatures made according to Ramsay and Young.

From this data it is seen that the oils vary considerably

the viscosity index) differ considerably in accordance with differences in the chemical composition.

The viscosity index (Dean and Davis) of the residues of oil from Surakhany oils is 82, from a Balakhany heavy it is -20.

In Fig. 2 is shown the relation between the viscosity of narrow fractions and their boiling temperature—this data being taken from the book of V. L. Gurvitch, B. B. Kammer, and M. E. Lutzenko, *Distillation Curves of Oils*. From

this curve it is seen that at the same boiling temperature, as, for example, 425° C., the fraction from Surakhany paraffin oil has a viscosity of 2.25° E_{100} , but the fraction from Binagady oil a viscosity of 15° E_{100} .

Due to their low paraffin content most Apsheiron lubricating oils have a low pour-point. However, oils from Kara-Chukhur, Surakhany, Zyk, and some Romany oils, have a high pour-point.

Special oils, as transformer, turbine, and medicinal oils are produced from a number of Baku petroleum. Especially suited for the production of these oils is Balachany light and some Romany oils, from which, on a line with Dossor-Makat oils of the Emba Region, are produced widely known special oils.

In the lubricating-oil fractions of Surakhany oil, as well as in the light fractions, the paraffin hydrocarbons have an *iso*-structure, that is, they contain ceresines—and for this reason it is impossible to obtain paraffin wax by means of pressing and sweating from these oils and also from Kara-Chukhur oils.

Due to the content of 'resinous substances' in Binagady and Artem oils and the high specific gravity of the oil fractions, high-quality residual bitumens are obtained from these oils which have a good relation of ductility and penetration and a high specific gravity.

Highway bitumens are obtained from other Baku oils as Balakhany heavy and Bibi-Eibat, but they are, however, inferior to the above in quality.

It stands to reason that from Surakhany paraffinic oils, residual bitumens cannot be obtained, due to their small content of tarry matter and to the low specific gravity of oil fraction.

The residue of Surakhany paraffin oil, consisting of 22% of the oil, usually goes into the manufacture of bright stock. The quality of the initial raw material and the finished product may be seen in Table VIII.

TABLE VIII

Name of product	Specific gravity	Viscosity E_{100}	Pour-point, °C.	Colour N.P.A.	Flash-point, °C.	
					Martin Pinsky	Cleveland
Cylinder stock	0.918	4.5	-1.38
Bright stock	0.908	3.66	-14	6	250	270

The yield of petrolatum (melting-point 60° C.) is approximately half as much as the yield of bright stock. Petrolatum is the raw material for obtaining vaseline and ceresine.

Kara-Chukhur and Zyk oil can also be used for the production of bright stock, but the yield of petrolatum in this case will be greater.

Naphthenic acids have recently received broad application in the U.S.S.R., Germany, and a number of other countries, due to their good cleaning and antiseptic properties. Their content in the most important Baku oils is given in Table IX.

TABLE IX

Oil	Content of naphthenic acids, %	Acid number of naphthenic acids
Surakhany paraffinic.	0.18-0.37	148-60
Balakhany light	1.09-1.20	182-6
Balakhany heavy	1.65-1.96	146-39
Bibi-Eibat light	0.66-0.86	162-74
Bibi-Eibat heavy	1.12-1.24	149-67
Binagady.	1.61	155
Artem	1.90	160

Thus, from these oils, we note that only Surakhany oil (having a paraffin base) is poor in naphthenic acid content. The other Apsheiron oils which are rich in paraffins, as Kara-Chukhur and Kala oils, are also low in naphthenic acid content.

It is interesting to trace how the properties of the oils of the Baku region change with the depth of the strata. It appears that in this respect it is not possible to make general conclusions for all regions. Still, it may be considered that, as deeper strata are gradually being exploited in the Apsheiron region, many of them yield oils with an increasing asphaltic content. Kerosine fractions from deeper oils in the same field have higher octane numbers; lubricating-oil fractions have higher specific gravities.

Thus, for example, in the higher strata of the Suzakhany field there occur oils which contain no asphalt whatever. They are light yellow, have a specific gravity of 0.720, and distil completely below 275° C. At a depth of 700-900 m. oils containing 7-8% of resinous substances are found. Oils obtained from a depth of 1,450 m. already contain 12% of resinous substances. Finally, oils from layers below 1,800 m. contain 30% of resinous substances. Depending on the depth of the original stratum, the octane number of Surakhany kerosine with the same boiling range (10% below 200° C., F.B.P. 300° C.) varies from 14 to 40. The specific gravity of a lubricating fraction of $E_{100} = 7^\circ$ obtained from a depth of 700 m. is 0.900, while that from a depth of more than 1,800 m. is 0.930.

Similar variations in the quality of oils in dependence on their depth (of course different for different oils) occur in a number of other Apsheiron fields (Kara-Chukhur, Binagady, &c.).

As for the influence of layer depths on the gasoline content of oils, a regular relationship is difficult to establish. In some fields, such as Kala, Surakhany, Balakhany, oils obtained from deeper layers contain less light fractions; of other fields the reverse is true; this is the case, e.g., with the Kara-Chukhur field. Thus the uppermost layers of the now thoroughly worked Surakhany field contain 70% of fractions distilling below 200° C. Oils from medium layers, about 700-800 m., contain 13-16%; finally, oils from the deepest strata contain only 8% of these fractions. The upper layers of the Kara-Chukhur field contain only 18% of these fractions, while the deepest layers contain 24%. Finally, the eighth stratum of the Bibi-Eibat field contains 22% of fractions boiling below 200° C., the fourteenth stratum contains 13.5%, i.e. considerably less; and the seventeenth stratum again shows an increase to 21%.

Thus in the production of oil from the deeper layers of the Baku fields, it will be seen that the lowering of the benzene fraction in the oils of one field is compensated for by an increase in another, and on the average it varies very little.

Naphtalan Field

The Naphtalan field is located 200 km. west of Baku.

In the total production of Soviet oil the Naphtalan oil plays a very small part—only a few tons are produced a day. Nevertheless, Naphtalan oil attracts very much attention.

This is explained by the fact that Naphtalan oil, in contrast to all other oils, is said to possess medicinal properties. There is a health resort right on the field where the treatment of many diseases is carried out by bathing in the oil. Among the diseases for which Naphtalan oil or its products are said to have curative properties are the

following: rheumatism, sciatica, eczema, rash and a number of other skin diseases, women's diseases, scald, erysipelas, &c. Naphtalan oil, or the products distilled from it, are made into special salves which have a wide distribution. Naphtalan oil is also used largely in veterinary science.

This oil has a high specific gravity (0.945), and viscosity (E_{25} 6.45, E_{100} 1.67), low pour-point (below -20° C.). In the content of 'resinous substances' (28%) and asphalts it does not exceed a number of other oils. The sulphur content is not extraordinarily high (0.465%).

In this oil there is no gasoline fraction and about 20% of kerosine. The kerosine fraction possesses much less curative properties than the heavier fractions.

There is a considerable amount of naphthenic acids in the oil (3%). Although in the literature there are references that naphthenic acids have curative properties—in view of the fact that naphthenic acids are entirely decomposed on distillation, and, moreover, that both the distillates and residues possess curative properties *not* less effective than the oil itself—it is not possible to attribute special medicinal properties to the naphthenic acids.

It is also not possible to attribute the special properties of the oil to its high radio-activity, as it is low.

The singular chemical composition of the oil fraction is given in Table X.

TABLE X

No.	Temperature range of cut, °C.	Hydrocarbon content		Molecular weight of naphthenic hydrocarbons	Average series	
		Aromatics %	Naphthenes %		Naphthenic hydrocarbons	Aromatic hydrocarbons
1	295-372	7	93	236.8	$C_{14}H_{28-29}$	$C_{16}H_{32-34}$
2	372-444	17	83	286.8	$C_{16}H_{32-33}$	$C_{18}H_{36-38}$
3	444-518	23	77	376.2	$C_{18}H_{36-37}$	$C_{20}H_{40-42}$

The naphthene hydrocarbons are very rich in cyclics. They contain on the average in the first fraction about 3 rings per molecule, in the second fraction 3 to 4, and in the third fraction 4 to 5, that is, considerably more than in other oils investigated in this connexion. The relation of the carbon and hydrogen in the naphthenes from all three fractions is fairly close to the formula of terpenes $C_{10}H_{16}$. This may explain the special properties of the Naphtalan oils.

The Georgian Region

The Georgian oil region is the second in Transcaucasia. This region at the present day is still not fully developed, but there are a large number of separate fields (about 40): the most important are Mirzaani and Shirki.

All of the Georgian region oils investigated up till now are distinguished by their high content of resinous substances, and therefore must be classed as asphaltic-base oils, although some of them are rich in paraffins.

The following products may be obtained from oils of both types:

	Type I	Type II
Gasoline (containing 30% of the fraction distilling to 100° C.)	%	%
Kerosine	6	17
Gas oil	11	20
Middle fraction	16	6
Asphaltic residue of high quality	13	33
	51	21

The oil fraction from type 2 oil is distinguished by its high pour-point. The unusually high yield of asphaltic residue from oil of the first type attracts attention.

In view of the greater importance of Mirzaani oils the following details are of interest.

These oils are distinguished by their high asphaltic content (42-5%) and at the same time by their low specific gravity (0.8680-0.8686). They contain only a small quantity of paraffins.

In conformity with the low specific gravity, the yield of gasoline is considerable (24%). The chemical composition of this is as follows: aromatics, 5%; naphthenes, 40%; and paraffins, 55%. Due to the large content of paraffin hydrocarbons, the octane number of the gasoline is not high (benzene equivalent 26). Kerosine with an initial boiling-point of 194° C. and end point 315° C. has a high specific gravity (0.850), and conforming to this fact it is rich in aromatic hydrocarbons (25%) and poor in paraffins (16%), with a naphthene content of 59%. In accordance with the high specific gravity, the high aromatic content, and small percentage of paraffins, the Mirzaani kerosine is more suitable as a tractor fuel than as an illuminant.

Oils from Mirzaani petroleum possess the properties of oils from asphaltic-base crudes (high specific gravity, low viscosity index, 10).

Due to the character of the Mirzaani residues (20%) after distillation, a high-quality bitumen for highways is obtained having good ductility and penetration characteristics.

From an examination of the properties of Georgian and Baku oils, their differences may be noted. In considering the properties of Apsheron oils it will be seen that in the case of a high content of resinous substances the percentage of gasoline is small. However, this is not the case with Georgian oils.

Furthermore, despite the small content of aromatics and, in separate cases, of paraffins, Apsheron gasolines have a high octane number, whereas Georgian gasolines have a lower value. This indicates a difference in structure of the hydrocarbons composing these oils. Thus Georgian oils do not have the distinctive properties of Apsheron oils. Consequently, there is no basis to claim that, from the point of view of the 'chemical contour' of oil regions, these regions are separate fields of one large region, as may be claimed for the Apsheron and Nebitdag fields. This latter field will be considered in more detail.

Grozny Region

The Grozny oil region is in north Caucasus near the city of Grozny. In this region there are two principal fields called the 'Old' and the 'New'.

Oils obtained from the 'New' field have a considerable paraffin content (4.5% by the Holdt method from preliminary distillation). Oils with a low paraffin content (0.35-0.7%) are obtained only from the top layers (1st and 2nd) in the western part of this field.

On the other hand, oils obtained from all layers in the 'Old' field have a low paraffin content. The content of paraffin in the oil, however, increases directly with increase in the depth of the strata (from 0.1 to 0.5%); and in the lower layers (12th and lower) of the western part of the field, oils are found with a high paraffin content (4.5%).

Despite the fact that a majority of Grozny oils contain considerable amounts of paraffin, they are distinguished by their high content of asphaltenes (1-2%) and 'resins'. Besides, there is a direct relation between the content of

'resinous substances' and asphaltene on the one hand and paraffins on the other. The higher the asphaltene content the lower the content of paraffins, and the same is true of the naphthenic acid content. They are almost absent in paraffin oils (0.02-0.03%) and are present up to 1.2% in paraffin-free oils. All Grozny oils contain only a very small percentage of sulphur (0.2%).

All of the Grozny oils without exception—including paraffinic, slightly paraffinic, and paraffin-free oils—are very rich in gasoline fractions. Besides, the poorer the oil is in paraffin and the richer it is in 'resinous substances', then the richer it will be in gasoline. The percentage composition of the gasoline fraction (to 200° C.) in various oils is as follows:

In paraffin oils	23-24%
In slightly paraffinic	25-27%
Paraffin-free	28-30%

The gasoline fractions from all Grozny oils contain relatively large quantities of aromatic hydrocarbons, as may be seen from the following figures given in Table XI.

TABLE XI

Oils from which the gasoline is obtained	Specific gravity	Percentage to 100° C.	End point, ° C.	Percentage hydrocarbon content		
				Aromatics	Naphthenes	Paraffins
1. Paraffinic	..	65	130	4	29	67
2. "	0.722	40	175	6	30	64
3. "	0.741	20	200	8	29	63
4. Slightly paraffinic	0.730	40	175	9	34	57
5. "	0.746	20	200	11	34	55
6. Paraffin-free from lower strata	0.730	40	175	8	36	56
7. "	0.746	20	200	11	37	52
8. Paraffin-free from upper strata	0.742	40	175	11	45	44
9. "	0.761	20	200	13	47	40

The data in this table shows that there is a somewhat larger percentage of aromatic hydrocarbons in Grozny gasoline than in that from Baku. At the same time, the Grozny gasolines have a considerable content of paraffins. The anti-knock properties of Grozny gasoline are much less than those of Baku oils, as will be evident from the data in Table XII.

TABLE XII

Oil from which gasoline is obtained	Specific gravity at 15° C.	Distillation according to American standards				End point, ° C.	Octane number
		Initial boiling point, ° C.	10%	50%	90%		
Paraffinic	0.691	30	50	80	105	132	62
"	0.707	38	58	93	122	150	58
"	0.737	45	73	129	179	193	44
Paraffin-free	0.723	40	149	58

The comparatively low octane number of Grozny gasoline in comparison with those of Baku is explained, not only by their high percentage of paraffins, but also by the fact that these paraffins have a normal structure. The composition of gasoline (to 150° C.) distilled from a mixture of Grozny oils is as follows:

TABLE XIII

No.	Name of hydrocarbon	Percentage composition calculated on fraction to 150° C.
1	iso-Pentane	2.1
2	n-Pentane	5.9
3	Cyclo-pentane	4.0
4	iso-Hexane	0.1
5	n-Hexane	7.6
6	Methyl cyclo-hexane	2.4
7	Cyclo-hexane	3.3
8	Benzene	0.3
9	iso-Heptane	4.4
10	n-Heptane	9.9
11	Hepta-naphthenes	10.1
12	Toluene	1.5
13	iso-Octane	9.0
14	Octo-naphthenes	6.8
15	n-Octane	8.9
16	Xylenes	3.2
17	Nono-naphthenes	5.8
18	iso-Nonane	8.6
19	n-Nonane	6.1

Hence the relation of the iso-paraffin hydrocarbons to the normal in Grozny gasoline (to 150° C.) is 0.67:1, while in Baku oils it equals 1.35:1.

The kerosine fractions from various Grozny oils differ markedly in their chemical composition, as may be seen from Table XIV.

TABLE XIV

Oil	Fraction, ° C.	Specific gravity	Hydrocarbon content		
			Aromatics %	Naphthenes %	Paraffins %
Paraffinic	200-300	0.819	17	22	61
Slightly paraffinic	"	0.824	20	29	51
Paraffin-free lower strata	"	0.846	25	39	36
Paraffin-free upper strata	"				
'Old' field	"	0.867	30	61	9

Therefore the kerosines from the paraffinic and slightly paraffinic oils are very rich in paraffin hydrocarbons, but those from paraffin-free oils of the upper strata of the 'Old' field, on the other hand, are very poor in them.

The content of aromatics in the kerosines from the paraffin-free oils is considerably greater than in those from the paraffinic oils.

Most Grozny kerosines have a low specific gravity, high content of paraffin hydrocarbons, and a very low octane number. The octane number of kerosine with I.B.P. of 202° C. and end point 312° C. is 8.

Due to its low octane number, Grozny kerosine is not considered as a tractor fuel. However, its chemical composition (nearly optimum aromatics content and high content of paraffins) indicates excellent properties as an illuminant. And, in fact, tests have shown that Grozny kerosine of normal fractional composition is a high-quality illuminant differing little in this respect from Pennsylvania kerosines. Even kerosine with an end point of 340° C. has quite good illuminating properties.

In short, Baku kerosine is a first-class tractor fuel, while Grozny kerosine is a high-quality illuminant.

The various lubricating oil fractions from Grozny differ sharply in their chemical composition. In Table XV data is given for the chemical compositions of the two oils which

TABLE XV

Oil	Viscosity E_{10}		d_{15}		n_{15}^{20}		Aniline point, °C.		Hydrocarbon content			Series after removing the aromatics	
	Temperature range, °C.	Before separation of aromatics	After separation of aromatics	Before separation of aromatics	After separation of aromatics	Before separation of aromatics	After separation of aromatics	Before separation of aromatics	After separation of aromatics	Aromatics %	Naphthenes %		Paraffins %
Paraffinic	350-400	1.29	1.27	0.866	0.825	1.4727	1.4581	87.4	93.6	14	52	34	C ₁₅ H ₃₂ 0.4
"	500-50	4.97	4.07	0.897	0.873	1.4895 (43')	1.4725	103.4	109.2	14	71	15	C ₁₅ H ₃₂ 1.2
Paraffin-free from top strata	350-400	1.45	1.38	0.900	0.864	1.4995	1.4707	74.8	84.4	38	62	..	C ₁₅ H ₃₂ 2
"	500-50	18.50	8.70	0.943	0.900	1.5212	1.4924	65.8	105.2	39	56	..	C ₁₅ H ₃₂ 3.3

differ most—that is, paraffinic oil and the paraffin-free oil from the top strata of the 'Old' field.

From Tables XIV and XV it is seen that the lubricating oil fractions, as well as the light fractions from Grozny oil, possess the distinguishing properties of products obtained from an oil with a paraffin base. They are characterized (at a given viscosity) by their low specific gravity and high flash-point. However, with increase in the boiling temperature, these distinguishing properties do not appear in the oil fractions as sharply as in the other paraffin-base oils. This may be seen from the high specific gravity of the heavy residue as shown in Table XXXIX at the end of the article.

The Grozny paraffinic oils contain a large amount of solid hydrocarbons. These hydrocarbons (in the fractions boiling to 550° C.), in distinction from those found in the Surakhany oil of the Baku region, are not ceresines but paraffins. For this reason paraffin wax is obtained from Grozny oil fractions up to and including machine oil, by means of pressing and sweating.

Since the higher fractions of Grozny oil contain ceresine, residual and distillate bright stocks may be obtained by centrifugal dewaxing in naphtha solution, or by treatment with liquid propane.

In consequence of the high 'resin' and asphaltene content in Grozny paraffin oil, a high-quality road bitumen is obtained in the residue of all these oils (about 12% calculated on the oil) after distillation in the vacuum-tube still of Foster-Wheeler or Alco type. The bitumen has, for example, the following properties:

Specific gravity 15° C.	1.02
Penetration at 25° C.	45
Ductility 25° C.	Higher than 100

The lubricating fractions from paraffin-free oils of the top layers of the 'New' field and lower layers of the 'Old' field do not in general possess a sufficiently low pour-point. The production of oils in Grozny at the present time is based on the paraffin-free oils of the 'Old' field. Usually, on distillation of such oil, the heaviest distillate obtained, for example, from the Foster-Wheeler vacuum unit has approximately the following properties: viscosity, E_{100} 6.2; specific gravity 0.950; flash-point (open cup) 260° C. The residue (12%) is a high-quality highway bitumen.

From all of the given material we may conclude that in direct proportion with depth of the oil layers in the 'Old' field, the oil contains more paraffin, less 'resinous substances', less naphthene acids; in the gasoline, and especially in the kerosene, less aromatics and more paraffin hydrocarbons; in the oil fractions, less aromatic hydrocarbons, while the naphthenes also contain less rings. The deepest layers of the 'Old' field contain almost the same type of

oil as the topmost strata of the 'New' field; and the deeper layers of the latter contain exclusively oils rich in paraffin. Thus the 'New' field, in the quality of its oils, is a continuation of the 'Old' field.

The following distinguishing properties characterize all the oils of this region: (1) high content of gasoline which has considerable amounts of aromatic hydrocarbons; (2) low sulphur content; (3) high content of tarry matter, providing the possibility of obtaining high-quality residual bitumens even from oils rich in paraffins.

Tersk Region

The Voznesensk and Malgobek fields are situated 100 km. east of Grozny. Geologists consider these fields as very promising.

Heavy oil, of specific gravity 0.920-0.937, is contained in the top layers of both these fields. As in the Grozny oils, considerable quantities of asphaltene (1-2½%) are present in them. The content of 'resinous substances' in these oils (35%) is more than in the Grozny paraffin-free oil, while the sulphur content does not exceed 0.5%. Furthermore, both oils have fairly large amounts of paraffin wax (more than 1%).

The chemical composition of heavy naphtha from Malgobek oil and of kerosene from both oils is given in Table XVI.

TABLE XVI

Product	From which oil	Temperature range, °C.	Specific gravity	Hydrocarbon content		
				Aromatics %	Naphthenes %	Paraffins %
Heavy naphtha	Malgobek	150-200	0.798	13	54	31
Kerosene	"	200-300	0.860	28	39	33
"	Voznesensk heavy	200-300	0.847	19	60	21

Despite its marked content of paraffin wax, the oil fractions from Malgobek oil are characterized by their low pour-point, with the exception of the very viscous oil fractions. This is explained by the fact that exceptionally high-boiling paraffins and ceresines are contained in the oil.

As a result of the general asphaltic character, the oil fractions are distinguished by high specific gravity, for example, with a viscosity 7.65° C. E_{10} = 0.932. For this reason it is possible to obtain from these oils a large yield of high-quality highway bitumen having a specific gravity greater than unity and a good relationship of penetration and ductility.

The octane numbers of the gasoline fractions from the light Voznesensk oil and from the heavy Voznesensk and heavy Malgobek oils are very high. The lubricating-oil fractions from the light oil have a high pour-point, but at the same time a considerably lower specific gravity than

from the heavy oil. Thus the fraction with a viscosity 6-9° E has a specific gravity 0.922 and pour-point 15° C.

In the Malgobek field, also, the oils from the deeper strata have a lighter character.

Daghestan District

The exploitation of the Daghestan district has begun only very recently. The district comprises three fields: Isberbash, Kaya-Kent, and Achi-Su. The crudes from these fields differ noticeably among themselves. Thus, while Kaya-Kent crudes are distinguished by a high asphalt content, the crudes from the other two fields are relatively poor in resinous substances (12-14%). All the crudes of the district are rich in paraffin, yet the paraffin content of Kaya-Kent oil (2.3, according to Golde) is considerably lower than that of Achi-Su (5.4) and Isberbash oils. The sulphur content of any crude of this district is below 0.3%. Crudes from Achi-Su and Isberbash contain a very high proportion of gasoline (about 30% of fractions boiling below 200° C.).

The octane numbers of gasolines from all Daghestan fields are approximately the same, namely about 60, for similar average boiling-points.

Kerosines derived from Kaya-Kent crude are distinguished by high octane numbers (40); those from the other two fields have considerable values. Lubricating-oil fractions from Kaya-Kent crudes have a high specific gravity. The residue, after distillation, makes a good road bitumen. Similar fractions derived from the other two fields show high pour-points. Since they are rather low in resinous substances and high in paraffins, they do not yield good bitumens.

The chemical composition of light Maikop gasoline may be seen from the following figures: aromatics, 16%; naphthenes, 40%; paraffins, 44%.

Thus Maikop gasoline contains a distinctly larger amount of aromatic hydrocarbons than Grozny benzine. However, the gasoline fraction of this oil, with approximately the same content of paraffin hydrocarbons as the Apsheon gasolines, has a lower octane number than the latter, as may be seen from the data in Table XVIII.

TABLE XVII

No.	Name of hydrocarbon	Percentage content calculated on fraction to 150° C.
1	<i>iso</i> -Pentane	2.2
2	<i>n</i> -Pentane	4.6
3	Cyclo-pentane	0.4
4	<i>iso</i> -Hexane	0.1
5	<i>n</i> -Hexane	8.6
6	Meta-cyclo-pentane	5.4
7	Cyclo-hexane	2.5
8	Benzene	2.1
9	<i>iso</i> -Heptane	2.8
10	<i>n</i> -Heptane	11.1
11	Hepta-naphthene	13.3
12	Toluene	4.7
13	<i>iso</i> -Octane	5.2
14	Octo-naphthene	6.9
15	<i>n</i> -Octane	7.9
16	Xylenes	6.5
17	Nono-naphthene	5.3
18	<i>iso</i> -Nonane	4.7
19	<i>n</i> -Nonane	3.5

The detailed chemical composition of gasoline from the oils under review is given in Table XVII.

TABLE XVIII

No.	Name of product	Specific gravity at 15° C.	I.B.P.	Distillation by American standards, °C.			Content of hydrocarbons			Octane number	
				10%	50%	90%	E.P.	Aromatics %	Naphthenes %		Paraffins %
1	Maikop	0.725	52	70	91	111	134	9	31	60	64
2	Maikop	0.735	57	77	104	134	153	12	29	59	60

Kuban-Black Sea Region

The Kuban-Black Sea region extends in a north-western direction from the meridian of Maikop along the northern slope of the principal Caucasian mountain range, along the shores of the Black Sea, and partly extends into the Crimean Peninsula.

In this region there are a large number of fields. In most cases heavy oils are found in the top strata of these fields, which very often contain neither gasoline nor heavy naphtha fractions, are very rich in 'resinous substances', and low in paraffin wax. However, the oils in the deeper layers usually contain a considerable amount of gasoline. The production from all these fields is small, with the exception of the Maikop-Shervan field, where light oil is obtained from the lower layers in such quantity that this region ranks third in the U.S.S.R. after Baku and Grozny.

This oil has a low specific gravity and low content of 'resinous substances' (12-14%). The amount of gasoline and heavy naphtha fractions (to 200° C.) in this oil is considerable, exceeding 30%. The fraction to 100° C. is also sufficient for the entire fraction to 200° C. to be used as a trade product, without the special addition of light fractions.

The relation of normal paraffin hydrocarbons to *iso*-paraffins in this oil is still lower than in Grozny gasoline and equals 0.47:1. This explains, to a large degree, at any rate, the lower octane number of Maikop gasoline compared to that from Apsheon oil.

The chemical composition of the kerosine fractions (200-300° C.) from a number of oils of the Kuban-Black Sea region is given in Table XIX.

TABLE XIX

Oil	Temperature range, °C.	Content of hydrocarbons		
		Aromatics %	Naphthenes %	Paraffins %
Light Maikop	200-300	29	36	35
Heavy Maikop	"	16	84	..
Kaluzhskiaia	"	12	88	..

As seen from this table, the chemical composition of the kerosine fractions from various Kuban-Black Sea oils differ quite markedly. The kerosine from light Maikop oil is very rich in aromatic hydrocarbons, which it is not possible to say of the kerosines from the other two oils.

Judging from their specific gravity (0.853) and index of

TABLE XX

Temperature range, °C.	Specific gravity of fraction		Aniline point, °C.		n _D ²⁰		Viscosity E ₂₀		Percentage content of hydrocarbons			
	Before separation of aromatics	After separation of aromatics	Before separation of aromatics	After separation of aromatics	Before separation of aromatics	After separation of aromatics	Before separation of aromatics	After separation of aromatics	Aromatics	Naphthenes	Paraffins	Unsaturated
350-400	0.916	0.890	63.2	76.1	1.5039	1.4863	1.67	1.62	23	74
500-535*	0.952	0.918	80.8	99.0	1.5275	1.5019	23.15	16.0	37	47

* Fraction not completely collected, due to beginning of decomposition.

refraction (n_D^{20} 1.4650), the naphthene hydrocarbons of Kaluzhskaia oil consist mostly of bicyclic compounds.

Inasmuch as the light Maikop oil varies sharply in this region, we shall go more into detail with the kerosine from this oil.

The octane number of kerosine with an I.B.P. of 212° C. and an end point of 320 C. is 31. Hence the Maikop kerosines occupy a middle position in this respect between Baku and Grozny. They are inferior to Grozny kerosine in illuminating properties, but all are of fairly good quality.

The lubricating-oil fractions of Maikop oil, as well as the lighter oils, are distinguished by the high content of aromatic hydrocarbons (30% in the light-oil fractions to 50% in the heavy). Some of the light Maikop crude oils contain paraffin hydrocarbons, and for this reason the heavier oil fractions have a high pour-point. The naphthenes in the light-oil fractions have an average of two rings, and in the heavier fractions (boiling range 500-550 C.) an average of three rings.

Along with the light Maikop oil there is obtained in the Kuban-Black Sea region a large number of other oils, having in most cases a pronounced asphaltic base. The chemical composition of two oil fractions from one of these oils (Kaluzhskaia) is given in Table XX.

The lubricating oil fractions from these oils have a low viscosity index, while a high-quality bitumen is obtained in the residue after distillation.

Emba Region

The Emba oil region extends from the lower course of the Ural River and north-eastern part of the Caspian Sea to the Temir River, that is, approximately 500 km. in a straight line. There is a large number of oilfields in this region, located in salt-domes. Three of these fields, Dossor, Makat, and Baichunas, have already been developed for a number of years. In recent years a number of other fields have been explored in detail. Several of them have been found to be quite prolific, and evidently in the near future they will become of prominent importance in the Emba region. These new fields include: South Iskine, situated near the old fields; Koschagil, located farther south of the Emba River near the Caspian Sea; Shubar-Kuduk, being in the south-eastern part of the region near the city of Temir.

The Emba oils have a number of properties, present exclusively in the oils of this region, and distinguishing them from the oils of all other regions.

The general characteristics of Emba oils are given in Table XXXVIII at the end of the article.

The oils of the Emba region are characterized by their low content of 'resin', asphaltenes, and sulphur. Only the Shubar-Kuduk oil is an exception. It contains a considerable amount of 'resin' and asphaltenes, and, moreover, a somewhat higher sulphur content to 0.5%. This oilfield is situated in the north-eastern part of the Emba region, and is possibly a transition to the fields along the northern Urals.

Oil from the fields being developed at the present time in the Emba region—Dossor, Makat, and Baichunas—contain practically no paraffin, and therefore many people consider the oils of the entire region as being poor in paraffin. However, recent researches show that the opposite statement is really true, that is, almost all the new oils investigated have a paraffin content greater than 1%. Emba oils in most cases have a low viscosity, with the exception of Makat, in which gasoline and heavy naphtha fractions are absent. In general, up to very recently it was considered that Emba oils altogether do not contain these fractions, or else in very small quantities. Moreover, the latest investigations show that oils from the newly opened fields located in various parts of this region contained marked and sometimes considerable quantities of gasoline and heavy naphtha fractions.

The content of the gasoline-heavy naphtha and kerosine fractions is given in Table XXXVIII at the end of the article.

The chemical composition of the gasoline and kerosine fractions of a number of Emba oils is given in Table XXI.

In reference to the chemical composition of the light fractions, the Emba oils have some general features which sharply distinguish them from the oils of other regions. Among these peculiarities must be mentioned the very small quantity of aromatic hydrocarbons. Both the gasoline and kerosine fractions contain markedly less aromatics than the same fractions of any other oil in the U.S.S.R. For example, in the kerosine fractions (that is, the fractions boiling in the ranges 200-300°C.) the amount of aromatic hydrocarbons for most of the investigated Emba oils does not exceed 8%—only in Dossor oil it reaches 11%—while in the fractions for all Grozny and Apsheiron oils the content of aromatics is higher than 16%. The relatively high content of unsaturated hydrocarbons is another general property of the chemical composition of the light fractions of Emba oils, and it is possible that they are formed on distillation. For example, the unsaturateds amount to 5% in the kerosine fractions of Makat and Shubar-Kuduk oils, while in the same fractions of the oils from other regions it seldom reaches 1%.

TABLE XXI

Oil	Product	Percentage of hydrocarbons			
		Aromatics	Naphthenes	Paraffins	Unsaturateds
Dossor	Gasoline	6.40	61.31	33.99	7.6
	Kerosine	11.20	63.80	25.00	6.6
Makat	Gasoline
	Kerosine	7.30	75.30	12.60	4.80
Shubar-Kuduk	Gasoline	3.49	44.54	51.12	0.83
	Kerosine	7.89	57.39	29.52	5.18
Sagis	Gasoline	5.00	46.50	53.15	1.35
	Kerosine	4.90	59.20	30.40	..
Tamdikul	Gasoline	2.60	59.90	34.10	3.40
	Kerosine	6.00	27.00	7.30	3.00
Koschagil	Gasoline	6.30	66.70	22.80	4.4
	Kerosine	7.60	60.80	21.2	10.4

Gasolines and kerosines from the majority of Emba oils contain a considerable percentage of naphthenic hydrocarbons; and have high octane numbers. Thus a heavy gasoline from Dossor oil has an octane number of 71.5, a gasoline from Koschagil oil an octane number of 78.5, while a kerosine from Makat oil (208–283° C.) has an octane number of 57.

The lubricating-oil fractions also contain a relatively small quantity of aromatic hydrocarbons, as may be seen from the chemical composition, for example, of Dossor Koschagil oils, given in Table XXII.

similar to those obtained from Dossor oil, do not need to be deparaffinized as they already have a pour-point of –15° C. Oil obtained from Dossor crude has a low specific gravity and good viscosity index. Hence, Dossor oil may be classed as a paraffin-base oil, although it contains very insignificant quantities of paraffin.

The oil fractions from South Iskine crude oil have an especially low specific gravity. See Table XXXVIII at the end of the article.

From an examination of this table, we see that the solar oil distillate from South Iskine crude contains, for example,

TABLE XXII

Temperature range, °C.	Percentage content based on crude oil	Specific gravity 15° C.		Aniline point of fraction, °C.		Coefficient of refraction		Viscosity E_{100}	Hydrocarbon content in fractions				Series of the naphthene hydrocarbons
		Before separation of aromatics	After separation of aromatics	Before separation of aromatics	After separation of aromatics	Before separation of aromatics	After separation of aromatics		Aromatics %	Naphthenes %	Paraffins %	Unsaturated %	
350–400	9.7	0.881	0.865	79.6	87.6	1.4850	1.4749	1.40	16	83	$C_{10}H_{18-17}$
500–550	7.4	0.897	0.877	106.8	113.4	1.4952	1.4796	6.41	10	82	..	3	$C_{10}H_{18-21}$
350–400	7.0	0.886	0.853*	82.4	87.6*	1.4809	1.4720*	1.38	11	82	2	5	$C_{10}H_{18-19}$
500–550	10.8	0.896	0.881*	103.4	09.0*	1.4942	1.4830*	6.24	14	64	11	11	$C_{10}H_{18-22}$

After deparaffinization and removal of aromatics.

A characteristic feature of this crude oil, as well as other oils in the Emba region, is that the naphthenes in the lighter oil fractions have a comparatively high specific gravity and coefficient of refraction, as, for example, in the fraction 350–400° C., the naphthenes have a specific gravity of 0.865, which is approximately the same as that of the corresponding fractions from heavy Grozny paraffin-free oils of the top strata (0.864). But in proportion with an increase in the boiling range of the fraction, the specific gravity and coefficient of refraction of the naphthene hydrocarbons from Emba oils changes only slightly; and as a result the naphthene hydrocarbons from heavier fractions are close in their properties to those of the corresponding fractions of Surakhany oil. This takes place because the naphthene hydrocarbons of all fractions, as, for example, of Dossor oil, contain, without relation to the boiling temperature, on an average two rings with an increased length of the side chains.

The general chemical composition of the oil fractions keeps its character essentially in the other oils of the Emba region, except that in some of them paraffin hydrocarbons are present.

As a consequence of the low content of resinous substances in the crude oil, and the character of the hydrocarbons, residual oils of the bright stock type may be obtained from several Emba oils. A number of them,

the same flash-point as the light cylinder oil from Okha crude of the third layer; the specific gravity of the residual aviation oil from South Iskine crude (0.878) is considerably lighter than the gas oil from a number of Baku oils.

The viscosity index of the residual oil from this crude even before treating is very high:

TABLE XXIII

E_{100}	E_{100}	Viscosity index
29-12	4.51	119
25-19	3.75	110

Thus the residual oils from South Iskine oil have a considerably better viscosity index than Pennsylvania oils.

Sterlitamak, Chusov, and Uchta Regions

Along the central and southern part of the Ural Mountains and in its immediate vicinity are situated three oil-fields: (1) Sterlitamak, near Shimbavoo on the Belaya River; (2) Chusov, near Chusov River, a little farther east of Perm; and (3) Uchta, half-way between the source and the mouth of the Uchta and Sed Rivers, which are tributaries of the Pechora River (Table XXIV).

The distance between the Sterlitamak and Uchta fields exceeds 1,000 km.

Although the Sterlitamak field began to be commercially developed only this year (1934), the drilling of a number

TABLE XXIV

Oil	No. of well	Specific gravity	Viscosity		Pour-point, °C.	Flash-point, °C.	% Excise resin	% Asphaltenes	% Coke	% Sulphur	% Paraffin (by Holdel) with destruction	Acidity in mg of KOH
			E_{100}	E_{50}								
Uchta	B/RTN	0.871	4.28	2.12	–20 flows	+16.5	47.0	2.72	6.19	1.12	2.08	0.63
Chusov	20	0.954	3.42	1.74	–20 flows	–7.0	54.5	5.20	9.30	5.40	1.20	..
Sterlitamak	702	0.872	2.33	1.54	–20 flows	–15.0	29.4	..	4.70	2.50	1.41	0.093

of wells has proved that it has a very great industrial significance and is one of the most prolific in the U.S.S.R.

Oils of all these fields are distinguished by their very high percentage of sulphur and by the high content of resinous substances. At the same time, these oils contain a marked quantity of paraffin wax. These properties sharply distinguish the oils of these new fields from the oils of the Caucasus and South Emba, since the latter contain only a few tenths per cent. of sulphur.

Moreover, those oils from the Caucasus which contain considerable amounts of paraffin usually have much less 'resin'.

On the other hand, the Uchta, Sterlitamak, and Chusov oils differ sharply in their specific gravities, as may be explained to a large degree by the variation in the chemical composition of the light fractions. The content of the gasoline fraction in the oils of these fields is approximately the same (from 21 to 26%), but the chemical composition differs considerably (see Table XXV).

TABLE XXV

Gasoline	Percentage of hydrocarbons			
	Aromatic	Naphthenes	Paraffins	Unsaturateds
Uchta	3.51	28.7	65.7	about 2
Chusov	46.41	23.9	29.7	..
Sterlitamak	16.01	24.0	60.0	..

While the Chusov oil has a very high content of aromatic hydrocarbons, in this respect containing at least twice as many as any other oil in the Soviet Union, Uchta oil is very low in aromatics (3.5%), and Sterlitamak oil occupies a place midway between these two oils (16%).

Due to the large content of paraffin hydrocarbons, the octane number of gasolines from Sterlitamak oil is not high, as is evident from the data in Table XXVI.

TABLE XXVI

Specific gravity	Percentage to 100° C.	End point, °C.	Octane number
0.717	60	135	55
0.759	20	200	49

Hence it is necessary to re-form the gasoline from this oil. The chemical composition of the kerosine fractions of Sterlitamak and Chusov oil is given in Table XXVII.

TABLE XXVII

Kerosine from	Temperature range, °C.	Percentage of hydrocarbons		
		Aromatics	Naphthenes	Paraffins
Sterlitamak oil	200-300	30.0	30.0	39
Chusov oil	200-300	54	18	28

According to its properties, Sterlitamak kerosine is more suitable as tractor fuel than as an illuminant. However, in view of its high content of paraffin hydrocarbons, if a large part of the aromatics were removed (as, for example, by the Edlecanu process), then Sterlitamak kerosine would make a good illuminating oil.

The distribution of sulphur in the various sulphur compounds of the gasoline and kerosine fractions of Sterlitamak oil is given in Table XXVIII. The analysis was made according to the method of Faragher, Morrel, and Monroe.

TABLE XXVIII

No.	Name of sulphur compounds	Sterlitamak oil	
		From I.B.P. to 200° C. %	200-300° C. %
1	Hydrogen sulphide	0.35	0.048
2	Elemental sulphur	0.047	0.062
3	Mercaptans	0.25	0.184
4	Disulphides	0.021	0.16
5	Sulphides	0.17	0.26
6	Thiophenes	none	none
7	Remaining sulphur	0.085	0.018
	Total sulphur	0.93	2.2

The large amount of 'remaining sulphur' in the kerosine fractions indicates the presence of considerable thiophanes. The quality of the residues from all three oils, after distilling off the gasoline and kerosine fractions to 300° C., is very similar. They all have high specific gravities. Thus the specific gravity of the residue of Chusov oil, as well as the residues from a number of Uchta oils, is more than 1.0, a value considerably higher than that of similar residues from all other oils. The residue from Sterlitamak oil has the high specific gravity of 0.960.

The residues ('mazouts') of all three oils are high in 'resinous substances', paraffin wax and sulphur, and are low in naphthenic acids.

The high specific gravity of the residues is explained by the high content of aromatic hydrocarbons, as may be seen from their chemical composition, which is given for two fractions in Table XXIX.

The hydrocarbons remaining after the separation of the aromatics possess for both oils a low specific gravity and a high aniline point, which are approximately the same as those of the corresponding fractions from oils with a paraffin base as Surakhyan, Dossor, and Grozny paraffinic. This may well be seen from the following figures in Table XXX for the fraction 450-500° C. from which the aromatic fractions have been removed.

TABLE XXIX

Oil	Temperature range, °C.	Viscosity E_{10}		Specific gravity		Refractive Index		Aniline point, °C.		Content of hydrocarbons			
		Before separation of aromatics	After separation of aromatics	Before separation of aromatics	After separation of aromatics	Before separation of aromatics	After separation of aromatics	Before separation of aromatics	After separation of aromatics	Aromatics %	Naphthenes %	Paraffins %	Unsaturateds %
		Sterlitamak	300-400	1.31	1.26	0.8837	0.8291	1.4957	1.4647	71.8	98.3	39	30
"	300-50	0.98	3.04	0.9340	0.8661	1.5125	1.4691	83.0	109.2	62	30	10	8
Chusov	347-97	1.37	..	0.962	0.828	1.5362	1.4610	46.6	93.2	70	19	11	..
"	497-517	18.3	..	1.020	0.891	1.5672	1.4777	60.2	104.4	72	24	4	..

TABLE XXX

From which oil the aromatic fractions are	Fraction, °C.	Specific gravity	Aniline point, °C.
Emba	450-500	0.873	97.6
Surakhany	"	0.865	103.2
Chusov	"	0.872	102.8
Sterlitamak	"	0.870	104.2

Consequently, it is necessary to assume that the naphthenic hydrocarbons from Chusov and Sterlitamak oils possess on an average not more than two rings. This is unusual for oils with a pronounced asphaltic base, and evidently is a special characteristic of the oils under consideration.

Due to the high content of aromatic hydrocarbons, the lubricating oils have a poor viscosity index. However, in view of the special chemical composition of the oils of the northern Urals, lubricating oils with a good viscosity index could be obtained by removing a large part of the aromatics (by special solvents) and the paraffin wax (to lower the pour-points).

All these oils, Sterlitamak, Chusov, and Uchta, have a high content of "resinous substances" and aromatics in their heavier fractions, and therefore high-quality residual road bitumens are obtained in yields of 20-30%, calculated on the oil. The specific gravity, for example, of the bitumen from Chusov oil is 1.08.

Thus, despite the fact that the distance between the Sterlitamak and Uchta fields is more than 1,000 km., the similarity of these oils (without depending on whether they are found in sands or limestone) allows us to assume that they all belong to one great oil region, and that in this region most still be found a whole series of oilfields with oils of approximately the same quality. And, in fact, oil has recently been discovered near Stavropol on the Volga possessing all of the basic properties of the oils under review. This broadens the region 400 km. to the west. Finally, in the immediate vicinity of Perm, oil has more recently been found also having similar properties. All this together shows that near the central and northern Urals there is a vast oil region. At the present time measures are being taken for its rapid exploration and development.

Turkmenian Region

The Turkmenian region is situated along the southern part of the eastern shore of the Caspian Sea and on Cheleken Island.

At the beginning of this century paraffinic oil was obtained on Cheleken Island, but now, however, the top strata are already exhausted. Geological data indicated that deeper layers of paraffin-free oil are to be found on this island of oil collected in the craters of mud volcanoes.

On the continent there are a number of oilfields. Sharply distinguished from the rest by its prolificness is Nebitdag, which at the present time is being developed and where a number of powerful gushers have recently been struck.

The oils of this field in most of its oil-bearing strata are distinguished by their very small content of both sulphur and paraffin wax. In its sulphur content the oil of this field recalls the Baku oils.

In the oil there is contained a notable quantity of the fraction to 200° C. (15%), although there is a relatively small quantity to 100° C. This also is similar to the Apsheon oils.

The chemical composition of Nebitdag crude is very similar to that of Bibi-Eibat light crude. Accordingly, the octane numbers of gasolines and kerosines, as well as

the properties of lubricating oils from Nebitdag closely approximate the corresponding data of fractions from Bibi-Eibat light crude. Similarly, to these oils also a road bitumen is obtained from Nebitdag oil, which, however, is only of average quality.

All the properties of Nebitdag oil are similar to those of Apsheon oils, which indicates that Nebitdag and Apsheon oils apparently belong to one oil region, and hence we may assume that under the Caspian Sea, on a line between Apsheon and Nebitdag, are located oil-bearing formations. This assumption is supported by geological data.

As is known, a large area of the Caspian Sea, near Baku, has been filled in, and at the present time large quantities of oil are obtained there.

Fergana Region

In the Fergana region three oilfields are being developed at the present time: Chimion, Kim (Santo), and Shorsu.

The quality of the crude oil of this region is given at the end of the article (Table XXXVIII).

The oils of all fields have a comparatively low specific gravity, low viscosity, high "resin" content, high content of paraffins; Shorsu oils are distinguished, moreover, by their high sulphur content.

Oils of the Fergana fields contain a large amount of gasoline fractions, boiling to 200° C. (from 15 to 25%), and approximately the same quantity of kerosine and light gas-oil fractions (15-18%).

Comparative data for the content of various groups of hydrocarbons in the gasoline and kerosine fractions of Chimion, Kim, and Shorsu oils are given in Table XXXI.

TABLE XXXI

Oils	Products	Percentage of hydrocarbons				
		Aromatics	Naphthenes	Paraffins	Unsaturates	
Chimion	Gasoline	12.2	42.3	45.49	0.05	
	Kerosine	16.5	37.6	45.1	0.8	
Kim	Gasoline	12.1	38.7	49.1	..	
	Kerosine	13.0	48.0	38.0	..	
Shorsu	Gasoline	11.6	29.7	58.5	..	
	Kerosine	22.3	43.6	34.1	..	

The chemical composition of gasoline and kerosine fractions of Kim and Chimion regions are similar to each other. The chemical composition of these fractions of Shorsu crude differs somewhat, but both have the same character as the oils of the other two fields. According to their chemical classification, they all are mixed paraffin-naphthenic-aromatic-base oils. In the relationship of the various fractions, these occupy a place between the Baku and Grozny crude oils, in regard to their quality as automobile and tractor fuels.

The distribution of sulphur in the various sulphur compounds, present in these fractions from Shorsu oil, may be seen from the following figures:

TABLE XXXII

	From initial to 200° C.	From 200° C. to 300° C.
Hydrogen sulphide	0.072	0.055
Elementary sulphur	0.052	0.035
Mercaptans	0.020	0.040
Disulphides	0.036	0.016
Sulphides	0.058	0.037
Thiophenes	traces	traces
Remaining sulphur	0.113	0.444
Total sulphur by Lamp method	0.351	0.627

The oil fractions from Fergana crude are characterized by a high pour-point. Despite the fact that the specific gravity of the viscous oil distillates is higher than, for example, those of Grozny paraffinic crude, they are distinguished by an unusually high flash-point. For example, the oil fractions from Shorsu crude with a viscosity of 5-7° E_{60} have a specific gravity of 0.923 and a flash-point of 242° C., that is, they have a higher flash-point than any other Soviet oil, with the exception of South Iskine, where the distillate of this viscosity has a specific gravity of 0.875.

Despite the high content of sulphur in Shorsu crude, the sulphur content in the oil distillates from this oil does not exceed 0.8%.

Due to the considerable amount of 'resinous substances' in several of the oils of this region, as, for example, Kim, it is possible to obtain a satisfactory grade of residual highway bitumen.

Sakhalin Region

In the northern part of Sakhalin, belonging to the U.S.S.R., there is a whole series of oilfields, almost all of which are situated along the eastern shore of the island. The most important fields are Okha, Nutov, Ekhabi, Chakri, Langri, and Katangli. However, at the present time only the Okha field, located on the northern border of the oil-bearing strip, is being developed.

In this field a large number of layers have been opened. Almost all of the properties of the Ocha crude change with increase in the depth of the bed. Thus the specific gravity decreases markedly with depth, as well as the viscosity, flash-point, and organic acids of the crude. On the other hand, the paraffin content increases markedly with depth of the strata. The sulphur content is approximately the same in oils of the 3rd and 8th layers, but is considerably lower in oils of the 11th and 12th layers.

The change of all the properties is connected both with the considerably large quantity of light fractions in the deeper beds and with the chemical composition of all fractions.

While the crude in the 3rd layer has 6% to 200° C., that of the 11th and 12th layers has 23% to 200° C. The chemical composition of fractions (boiling at 200°) from crude of the 11th and 12th strata is seen from the following table.

TABLE XXXIII

No. of the stratum	Temperature range	Percentage content of hydrocarbons			
		Aromatics	Naphthenes	Paraffins	Unsaturateds
7	Initial to 200° C.	5-1	75-4	19-7	0-0
11-12	"	11-7	60-88	27-0	0-41

Hence the naphthene hydrocarbons prevail in Okha crude. The same fractions for oils of the deeper strata

possess a lower specific gravity and lower coefficient of refraction; at the same time it has at first glance the following paradoxical relationship: gasoline fractions, distilled from various oils, in the same boiling range, contain less aromatic hydrocarbons, the heavier the crude from which it is obtained and the higher the specific gravity of the fraction. This may be confirmed in Table XXXIV.

TABLE XXXIV

Number of stratum	Temperature range, ° C.	Specific gravity	Content of aromatic hydrocarbons %
3	150-200	0.830	5.6
7	"	0.812	7.2
11-12	"	0.810	10.8

The octane number of the gasoline fraction from the oil of the 11th and 12th strata, having an end point of 155° C. and containing 20% to 100° C., is 66.

The octane number of the kerosine fraction from the crude of the 7th layer (which is of average quality) is unusually high, 55. This is explained by the fact that the kerosine contains a very large amount of naphthene hydrocarbons having two rings.

The chemical composition of the kerosine fraction (200-300° C.) is given in Table XXXV.

TABLE XXXV

No. of the stratum	Temperature range, ° C.	Percentage content of hydrocarbons			
		Aromatics	Naphthenes	Paraffins	Unsaturateds
3	200-300	18.8	78.7	..	2.5
7	"	16.7	82.3
11-12	"	25.0	60.2	14.8	..

Although the kerosine fractions from the oil of deeper strata contain more aromatic hydrocarbons than those fractions from oil of the upper strata, they are considerably better illuminants than the latter, due to the total character of the remaining part of the kerosine minus the aromatics. Thus the specific gravity of the aromatic-free fraction 200-250° C. is 0.8583 when obtained from the 3rd layer, 0.8458 from the 7th layer, and 0.8257 from the 11th-12th layers.

The oils from crude of the lower strata are much less asphaltic in character, but they contain a large quantity of paraffin and therefore the oils have a higher pour-point.

A considerable quantity of residual highway bitumen is obtained after distillation (for the 3rd layer, 25%), which in its relationship of ductility and penetration is much better than any other bitumen in the U.S.S.R. Thus with a penetration of 5 (by Richardson) at 25° C. the ductility is higher than 120. The yield of highway bitumen is less for oils from the deeper strata, and from the 11th-12th layers it is 18%.

SELECTED BIBLIOGRAPHY

Aznert Central Chemical Laboratory. Research of Apsheron Crude Oils. Special edition of *Journal Neft. Khoz.*, 1926.
 BESTUSHEFF, M. N., and MALASHKIN, P. A. Maikop Crude Oil. *Neft. Khoz.* no. 6, 1930.
 BUCH, D. Research of Crude Oils from the Islands of Artem. *Neft. Khoz.* no. 3, 1930.
 BUTORN, N., LISTZIN, P., and VORONOFF, A. Malgobek Crude Oil from well No. 8 and Heavy Oils of the Terak Region. *Groznynskiy Neftyanik*, nos. 3-4, 1933.
 EMMUEL, V., and NOSOFSKAYA, G. Research of Georgian Crude Oils. *Neft. Khoz.* no. 8, 1929.
 GOLDBERG, D. O. The Content of Naphthenic Acids in Apsheron Crude Oils. *Neft. Khoz.* no. 3, 1934.

GRAMENTITSKY, M. D. Crude Oils of the Emba Region. *Neft. Khoz.* no. 4, 1929.
 GURVITCH, V. L., KAMINER, B. B., and LUTZENKO, M. I. *Distillation Curves of Crude Oils*, Baku, 1933. O.N.T.I. Azneftizdat, Baku, 1933.
Handbook of the Oil Industry. Central Direction of Printing, Supreme Economic Council, 1925.
 KAZARNOVSKAYA, M. A., and COCHINA, A. S. The Sulphur Content of Shorsu Crude Oils.*
 NEMETSKIN, S. S. Research of Ural (Perm) Crude Oils. *Neft. Khoz.* no. 7, 1929.
 PAVLOVA, C. N., and HOPMAN, P. S. Ukhta Crude Oil.*
 — Research of the Crude Oils from the Shorsu Fields.*
 PAVLOVA, S. N. Research of Crude Oils from the Kim Fields.*

PLOTKO, A. *Resources of the Gasoline, Kerosine and Gas Oil Fractions in the Baku Crude Oils.* O.N.T.I. Azneftizdat, Baku, 1932.
 — Research of Georgian Oils. *Neft. Khoz.* no. 10, 1931.
 PLOTKO, A. M. Kola Crude Oil. *Neft. Khoz.* no. 9, 1933.
 — Lok-Batan Crude Oil. *Neft. Khoz.* no. 9, 1933.
Proceedings of the Grozneft Central Laboratory, 1927. Summary of the Research on Grozny Crude Oils.
 ROBINSON, E. A. Chemical Composition of Okhinsky Crude Oil.*
 — The Chemical Composition of Sterlitamak Crude Oil. *Neft. Khoz.* no. 6, 1934.*
 SOKHANOFF, A. N., and SELSKY, L. A. On the question of the Content of Gasoline in Grozny Crude Oils. *Neft. Khoz.* no. 1, 1929.
 SOKHANOFF, A. N., and SHERDEVA, N. A. Chemical Characteristics of Paraffins and Ceresines—Surakhani Paraffins and Ceresines.†
 SOKHANOFF, A. N., and VASILYEV, N. A. Chemical Characteristics of Grozny Paraffins and Ceresines.†
 — Vosnesensk Crude Oil. *Neft. Khoz.* no. 3, 1927.
 SOKHANOFF, A. N., and VIROYANZ, R. A. Methods for Determining the Chemical Composition of Kerosine and Oil Fractions.†
 — Chemical Composition and Classification of Oils.†
 VELIKOVSKY, A. S., and PAVLOVA, S. N. Research of Sterlitamak Crude Oil. *Neft. Khoz.* no. 10, 1932.

VELIKOVSKY, A. S., and PAVLOVA, S. N. Crude Oils of the Sterlitamak Field and the Chemical Contour of the Region. *Neft. Khoz.* no. 6, 1934.
 — Turkmenian Crude Oils.*
 — Research of the Okha Crude Oils.*
 VIROYANZ, R. A., GOVAKOFF, V. P., and GABRIYELYANZ, S. M. *Detailed Research of the Anti-Knock Properties and Chemical Composition of Straight Run Gasoline.* O.N.T.I. Azneftizdat, Baku, 1933.
 WOLF, M. The Quality of Baku Gasolines and Heavy Naphthas and the Question of their Mixtures. *Neft. Khoz.* no. 6, 1932.
 WOLF, M., and SHEVLAKOFF. Chemical Composition of Baku Gasoline. *Neft. Khoz.* nos. 9-10, 1931.
 ZELANSKY, V. E. *The Detonation of Motor-fuel and Methods for its Measurement.* O.N.T.I. Azneftizdat, Baku, 1933.
 * These articles are to be found in *Oils, Bitumens and Gases from Oil Fields in USSR outside the Caucasus*, edited by Velikovsky and S. N. Pavlova. O.N.T.I. Mining, Geological, and Petroleum Publishing House, Moscow, 1934.
 † To be found in *Proceedings of the Grozny Petroleum Research Institute: Chemical Composition of Petroleum and Petroleum Products, State, Scientific.* Technical Publishing House, Moscow, 1931.

TABLE XXXVI
 Properties of Crude Oils of Grozny Region

No.	Name of crude oil	Grozny paraffin	Grozny paraffin-free	Malgobek	Voznesensk		
					Light	Heavy	Malgob
Crude oil	1 Research carried out by	Grozny	Grozny	Grozny	Grozny	Grozny	Grozny
	2 Density API, at 60° F.	37-4-34.9	35-6-29.3	21.2	25.7-24.9	22.3-19.5	38.9
	3 Specific gravity at 15° C.	0.838-0.850	0.847-0.880	0.927	0.900-0.905	0.920-0.937	0.830
	4 Temperature of loss of fluidity, °C.	Lower than 20° C.	Lower than 20° C.	Lower than 18° C.	20 ° C	20 ° C	Lower than 20° C
	5 Engler viscosity at 10° C.	48.4	12.0-16.8	64-154	1-32
	6 Engler viscosity at 50° C.	5.1	2.23-2.82	5.22-8.05	..
	7 Sulphur % bomb	0.20	0.20	0.46	..	0.48	..
	8 Paraffin content, %; Hoide method with destruction	3.46-4.77	0.1-0.74	1.67	2.03	1.15-1.19	0.5
	9 Content of resinous substances, %	12-15	15-20	36	33	36	11
	10 Content of asphaltuene, %	0.92	1	39
	11 Acidity, %; SO ₂	0.028-0.044	0.088-0.11
Distillation with water refraction: Benzene: Initial point to 200° C.	1 Yield	22.7	28.3	4.8	6.6	..	38
	2 Specific gravity	0.740	0.749	0.806	0.785	..	0.753
	3 Initial boiling-point, °C.	61	54	134	47
	4 10%	87	87	140	81
	5 50%	128	133	168	112
	6 90%	194	179	198	175
	7 End point	201	203	215	204
	8 Sulphur content	0.01	0.015
Distillation with rectification Light Kerosine gas oil 270-300° C. 200-70° C.	1 Yield, %	13	12	11.07	12.21	6	16
	2 Specific gravity	0.813	0.830-0.860	0.864	..	0.850	0.837
	3 Sulphur content, %	0.02	0.04
Distillation with rectification Light Mazout above 270-300° C.	1 Yield, %	7	7	5.3	5.0
	2 Specific gravity	0.833	0.850-0.880	0.876
Distillation with rectification Mazout above 300° C.	1 Yield %	57-60	53-67	78	80.9	..	45.7
	2 Specific gravity	0.910	0.920	0.952	0.926	..	0.920
	3 Engler viscosity at 50° C.	6	8.0	27.9	6.13	..	4.8
	4 Flash-point	170	170	190	145
	5 Content of resinous substances, %	36	40	24	24
	6 Pour-point	+34	+28	+3	Lower than -17	..	-20

(1) Grozny Petroleum Research Institute.
 (2) Mazout above 270° C.

TABLE XXXVIII

Properties of Crude Oil from the Apsheron (Baku) Region

No.	Name of crude oil	Bakshahy			Sarakhany			Kapa-Chaur			Bibi-Ebhat			Loh-Boran			Atrom
		Light	Heavy	Remany	Upper layers	Lower layers	Kala	AZNI	Light	Heavy	Remany	Light	Heavy	Light	Heavy	AZNI	
1	Research carried out by	AZNI	AZNI	AZNI	AZNI	AZNI	AZNI	AZNI	AZNI	AZNI	AZNI	AZNI	AZNI	AZNI	AZNI	AZNI	
2	Density at 60° F.	12.2718	0.24-20.0	31.8-21.6	31.6-30.0	31.6-30.0	30.82-29.1	31.6-29.7	31.6-29.7	26.5-27.1	24.6-25.1	24.6-25.1	24.6-25.1	24.6-25.1	24.6-25.1	24.6-25.1	
3	Temperature of onset of fluidity, °C.	Lower than 20° C.	Lower than 20° C.	Lower than 20° C.	Lower than 20° C.	Lower than 20° C.	Lower than 20° C.	Lower than 20° C.	Lower than 20° C.	Lower than 20° C.	Lower than 20° C.	Lower than 20° C.	Lower than 20° C.	Lower than 20° C.	Lower than 20° C.	Lower than 20° C.	
4	Flash-point, °C.	132.0	132.0	132.0	132.0	132.0	132.0	132.0	132.0	132.0	132.0	132.0	132.0	132.0	132.0	132.0	
5	Endic viscosity at 107° C.	1.5-2.0	1.5-2.0	1.5-2.0	1.5-2.0	1.5-2.0	1.5-2.0	1.5-2.0	1.5-2.0	1.5-2.0	1.5-2.0	1.5-2.0	1.5-2.0	1.5-2.0	1.5-2.0	1.5-2.0	
6	Endic viscosity at 50° C.	1.5-2.0	1.5-2.0	1.5-2.0	1.5-2.0	1.5-2.0	1.5-2.0	1.5-2.0	1.5-2.0	1.5-2.0	1.5-2.0	1.5-2.0	1.5-2.0	1.5-2.0	1.5-2.0	1.5-2.0	
7	Stability constant, (1000)	0.0-0.12	0.0-0.12	0.0-0.12	0.0-0.12	0.0-0.12	0.0-0.12	0.0-0.12	0.0-0.12	0.0-0.12	0.0-0.12	0.0-0.12	0.0-0.12	0.0-0.12	0.0-0.12	0.0-0.12	
8	Water content, % (standard method)	12.8-18	22-30	10-15	5-8	28	14.0-17.5	5-7	3.6-5.6	0.0-0.16	0.16-0.18	0.16-0.18	0.16-0.18	0.16-0.18	0.16-0.18	0.16-0.18	
9	Content of substances with destruction	0.4-1.8	0.4-1.8	0.4-1.8	0.4-1.8	0.4-1.8	0.4-1.8	0.4-1.8	0.4-1.8	0.4-1.8	0.4-1.8	0.4-1.8	0.4-1.8	0.4-1.8	0.4-1.8	0.4-1.8	
10	Condition carbon content, %	0.04-0.18	0.10-0.16	0.06-0.19	0.02-0.06	0.13	0.04-0.07	0.09	1.3-1.7	1.7-2.2	1.7-2.2	1.7-2.2	1.7-2.2	1.7-2.2	1.7-2.2	1.7-2.2	
11	Viscosity (η _{sp} /c), 20°	0.552	0.805	0.756	0.760	0.9	0.807	0.762	0.838	0.725	0.748	0.755	0.755	0.755	0.755	0.755	
12	Specific gravity	0.819	0.885	0.884	0.884	0.889	0.889	0.889	0.889	0.889	0.889	0.889	0.889	0.889	0.889	0.889	
13	Specific gravity	0.819	0.885	0.884	0.884	0.889	0.889	0.889	0.889	0.889	0.889	0.889	0.889	0.889	0.889	0.889	
14	Specific gravity	0.819	0.885	0.884	0.884	0.889	0.889	0.889	0.889	0.889	0.889	0.889	0.889	0.889	0.889	0.889	
15	Specific gravity	0.819	0.885	0.884	0.884	0.889	0.889	0.889	0.889	0.889	0.889	0.889	0.889	0.889	0.889	0.889	
16	Specific gravity	0.819	0.885	0.884	0.884	0.889	0.889	0.889	0.889	0.889	0.889	0.889	0.889	0.889	0.889	0.889	
17	Specific gravity	0.819	0.885	0.884	0.884	0.889	0.889	0.889	0.889	0.889	0.889	0.889	0.889	0.889	0.889	0.889	
18	Specific gravity	0.819	0.885	0.884	0.884	0.889	0.889	0.889	0.889	0.889	0.889	0.889	0.889	0.889	0.889	0.889	
19	Specific gravity	0.819	0.885	0.884	0.884	0.889	0.889	0.889	0.889	0.889	0.889	0.889	0.889	0.889	0.889	0.889	
20	Specific gravity	0.819	0.885	0.884	0.884	0.889	0.889	0.889	0.889	0.889	0.889	0.889	0.889	0.889	0.889	0.889	
21	Yield, %	60	74.9	96.5	57.8	60.7	68.5	51.5	56.2	60.8	60.8	60.8	60.8	60.8	60.8	60.8	
22	Specific gravity	0.914	0.991	0.908	0.919	0.888	0.940	0.925	0.890	0.917	0.919	0.919	0.919	0.919	0.919	0.919	
23	Flash-point, °C.	152	166	159	165	152	160	160	166	161	166	166	166	166	166	166	
24	Content of carbon substances, %	Lower than 20°	Lower than 20°	Lower than 20°	Lower than 20°	Lower than 20°	Lower than 20°	Lower than 20°	Lower than 20°	Lower than 20°	Lower than 20°	Lower than 20°	Lower than 20°	Lower than 20°	Lower than 20°	Lower than 20°	
25	Water content, %	4.6	7.1	5.4	5.4	5.4	5.4	5.4	5.4	5.4	5.4	5.4	5.4	5.4	5.4	5.4	
26	Specific gravity	0.794	0.750	0.756	0.753	0.753	0.753	0.753	0.753	0.753	0.753	0.753	0.753	0.753	0.753	0.753	
27	Flash-point, °C.	104	104	104	104	104	104	104	104	104	104	104	104	104	104	104	
28	Flash-point, °C.	125	125	125	125	125	125	125	125	125	125	125	125	125	125	125	
29	Flash-point, °C.	133	133	133	133	133	133	133	133	133	133	133	133	133	133	133	
30	Flash-point, °C.	144	144	144	144	144	144	144	144	144	144	144	144	144	144	144	
31	Flash-point, °C.	160	160	160	160	160	160	160	160	160	160	160	160	160	160	160	
32	Flash-point, °C.	172	172	172	172	172	172	172	172	172	172	172	172	172	172	172	
33	Flash-point, °C.	198	198	198	198	198	198	198	198	198	198	198	198	198	198	198	
34	Flash-point, °C.	203	203	203	203	203	203	203	203	203	203	203	203	203	203	203	
35	Flash-point, °C.	223	223	223	223	223	223	223	223	223	223	223	223	223	223	223	
36	Flash-point, °C.	278	278	278	278	278	278	278	278	278	278	278	278	278	278	278	
37	Flash-point, °C.	281	281	281	281	281	281	281	281	281	281	281	281	281	281	281	
38	Flash-point, °C.	4.91	3.8	6.1	6.2	6.2	6.2	6.2	6.2	6.2	6.2	6.2	6.2	6.2	6.2	6.2	
39	Specific gravity	0.867	0.889	0.852	0.847	0.847	0.847	0.847	0.847	0.847	0.847	0.847	0.847	0.847	0.847	0.847	
40	Residue	65.3	76.6	59.6	60.8	59.6	60.8	60.8	57.4	60	60	60	60	60	60	60	

* (1) Azerbaidjan Petroleum Research Institute

(2) Determined by the increase of the layer of sulphuric acid on shakins 50 c.c. of the material to be tested, diluted with 100 c.c. of benzene with 100 c.c. of sulphuric acid.

(3) The flash point is the maximum temperature of Amberon crude oil raised from 0.016 to 0.022°.

(4) Sulphur content of benzene distillate from Apsheron crude oil, each sample from 0.03 to 0.06%.

TABLE XXXVIII

Properties of Crude Oil outside of the Caucasus

No.	Name of crude oil	Distiller		Melat	South Bakine	Aeschazi		Stephanamak		Chasov	Ukhta	Nebhidag	Shoran	Ktin	3rd layer	OKha	
		2nd layer	3rd layer			GINI	GINI	GINI	GINI							GINI	GINI
1	Research carried out by Laboratory of the Constaninovsky works																
2	Specific gravity at 15° C.	0.878-0.897	0.868-0.829	31.3-25.5	43.6	31.6-22.3	31.0-29.3	16.8	0.951	0.871-0.880	0.871	0.888	0.873	0.857	33.6	22.5	0.919
3	Specific gravity at 20° C.	0.870-0.887	0.860-0.829	31.3-25.5	0.808	0.857-0.864	0.871-0.880	0.951	0.951	0.871	0.871	0.888	0.873	0.857	33.6	20.3	0.919
4	Flashpoint, °C. of base	40° C.	40° C.	40° C.	105° C.	45° C.	40° C.	40° C.	40° C.	40° C.	40° C.	40° C.	40° C.	40° C.	40° C.	40° C.	40° C.
5	Flashpoint, °C. of base	40° C.	40° C.	40° C.	126° C.	40° C.	40° C.	40° C.	40° C.	40° C.	40° C.	40° C.	40° C.	40° C.	40° C.	40° C.	40° C.
6	Enthalpy viscosity at 10° C.	1.97-2.18	1.40-1.44	2.96-2.75	1.26	1.67-1.55	1.31-1.65	5.09	5.09	1.12	1.12	1.14	1.12	1.12	3.25	24.25	15.49
7	Enthalpy viscosity at 20° C.	0.11-0.20	0.11-0.17	0.20-0.30	0.8	1.49-1.55	1.2-2.95	5.40	5.40	1.12	1.12	0.24	1.32-2.01	0.30	0.31	0.46	1.96
8	Paraffin content, %	0.12-0.13	0.11-0.26	0.40-0.64	1.75	0.73-1.18	1.31-1.53	1.20	1.20	2.08	2.08	0.53	3.0	2.5	0.03	0.69	1.13
9	Content of resinous substances	5.0-8.7	1.0-4.5	12-24	1.0	8-9	30.0-54.5	4.7	9.3	6.19	4.7	3.2	30.48	21-32	34	35	20
10	Content of carbonaceous substances	0.47-0.69	0.26-0.42	0.8-1.14	4.7	9.3	6.19	4.7	3.2	3.87	3.69	3.63	4.21	27	..
11	Acidity, %	0.88-2.18	0.02-0.157	0.02-0.057	0.021	0.0074	0.77-0.71	5.6	0.6045	0.32	0.32	0.010	0.0035	0.064	0.019	0.068	..
12	Acidity, %	0.25-0.75	0.4-0.25	0.04-0.26	34.8	17	24.4	24.4	21.5	15.5	18.1	24.4	6.4	6.4	10.0	25.4	..
1	Yield, %	0.750-0.770	0.750-0.770	0.750-0.770	0.043	0.780	0.759	0.792	0.11	0.774	0.744	0.759	0.795	0.785	0.774	0.774	..
2	Specific gravity	0.831-0.856	0.817-0.819	0.860-0.865	..	0.015	1.84	0.834	0.838	0.810
3	Sulphur content, %	10.8-23.9	27.9-31.0	2.4-11.8	19.0	16.8	13.6	4.3	14.0	16.5	10.8	14.0	16.6	16.5	20.6
4	Specific gravity	0.831-0.856	0.817-0.819	0.860-0.865	..	0.015	1.84	0.834	0.838	0.810
5	Sulphur content, %	13.1-21.5	16.7-19.6	7.4-15.4	..	0.860	6	..	6	40	4	66	7.5
6	Specific gravity	0.835-0.882	0.860-0.866	0.874-0.878	0.845	0.838
7	Specific gravity	0.835-0.882	0.860-0.866	0.874-0.878	0.845	0.838
1	Yield, %	66-75	55-60	78-89	46	57.0	53-56	..	59	64	67	55	70.0	..	70.0	0.962	56.0
2	Specific gravity	0.900-0.907	0.875-0.893	0.900-0.902	..	0.906	0.900	..	0.947	0.879	0.920	0.920	0.929	..	0.929	0.962	0.943
3	Flashpoint, °C.	3.88-4.52	3.05-3.48	5.38-9.17	..	9.44	18.0	..	15.2	21.2	11.3	15.9	22.9	..	22.9	16.9	16.9
4	Content of resinous substances	16	69	..	182	44.5	51	46.5	54.6	..	54.6
5	Content of carbonaceous substances
6	Flashpoint, °C.	Lower than 20° C.	Lower than 20° C.	-10	+3	..	+11	-12	+6	+12.5	-18	..	-18	..	8

TABLE XXXIX
Content of Lubricating-oil Fractions in Crude Oil

Region	No.	Name of crude oil	Fraction with a viscosity of 70 E _u 50/100 sec. Saybolt at 100° C.		Fraction with a viscosity of 30 E _u 100/200 sec. Saybolt at 100° C.		Fraction—higher viscosity 1,400 sec. Saybolt at 100° C.		Residue		Engler viscosity at 100° C.	Melting-point (Kramer Summary) C.	Flash, Point
			% yield on crude oil	Sp. gr. at 15° C.	% yield on crude oil	Sp. gr. at 15° C.	% yield on crude oil	Sp. gr. at 15° C.	% yield on crude oil	Sp. gr. at 15° C.			
Grozny	1	Smekhany paraffinic	17.5	0.847-0.877	8	0.877-0.895	10	0.895-0.914	15	0.913	335
	2	Lubricating oil—first quality	17	0.865-0.893	7	0.897-0.910	11	0.916-0.914	13	0.912	326
	3	Bakhsany heavy	11-6	0.885-0.917	10	0.917-0.932	40	0.932-0.954	15	0.997
	4	Bibi-Eibat light	12	0.875-0.905	5	0.905-0.915	23	0.915-0.939	15	0.975
	5	Bibi-Eibat heavy	14	0.885-0.915	6	0.915-0.925	8	0.925-0.940	30
	6	Bibi-Eibat	14	0.885-0.915	5	0.915-0.925	2	0.925-0.959	20.7	0.997
	7	Artemov	14	0.900-0.925	14	0.905-0.927	15	0.925-0.959	30.7	0.997
	8	Lok-Bisan light	14	0.880-0.901	5	0.901-0.917	12	0.917-0.940	14	0.990
	9	Lok-Bisan heavy	10	0.894-0.906	11	0.906-0.924	23	0.924-0.950	24.5	0.983
Grozny	10	Grozny paraffinic	16	0.838-0.872	11	0.872-0.890	12	0.890-0.912	30	0.936	6.2
	11	" paraffinic free	7	0.890-0.910	4	0.910-0.920	19	0.920-0.950	23	0.980	50
Makop	12	Makop	9	0.881-0.910	5	0.910-0.922	13	0.922-0.942	14
	13	Dzonor-Makot	20	0.875-0.890	14	0.890-0.895	12	0.895-0.903	30	0.913	3.8
Emba	14	S. Iakine	29	0.831-0.857	4	0.857-0.871	13	0.892	3.2	..	246
	15	Seritamak	11	0.872-0.910	7	0.910-0.928	17	0.928-0.958	23	1.01	281
Turknooian	16	Nebidag	12	0.860-0.890	6	0.890-0.905	23	0.905-0.930	23	0.986	3.0	18	..
	17	Shorna	16	0.867-0.893	7	0.893-0.904	5	0.904-0.962	39
Fergana	18	Kain	14	0.865-0.887	7	0.887-0.905	15	0.905-0.935	19
	19	Okha Layer 3	15	0.900-0.938	8	0.938-0.950	22	0.950-0.970	25	1.02
Sakhalin	20	Layer 1	12	0.888-0.914	15	0.914-0.922	22	0.922-0.968	21	1.02
	21	" Layer 11-12	20	0.865-0.905	4	0.905-0.915	15	0.915-0.950	15	1.02

TABLE XI
Quality of Lubricating-oil Fractions in Crude Oils of U.S.S.R.

Region	No.	Name of crude oil	Fractions with viscosity 17 E ₁₀			Fractions with viscosity 3.2 E ₁₀			Fractions with viscosity 7 E ₁₀			Fractions with viscosity 12 E ₁₀			Residue				
			Sp. gr.	Flash-point, °C.	Four-point, °C.	Sp. gr.	Flash-point, °C.	Four-point, °C.	Sp. gr.	Flash-point, °C.	Four-point, °C.	Sp. gr.	Flash-point, °C.	Four-point, °C.	Sp. gr.	Flash-point, °C.	Viscosity, E ₁₀₀	Flash-point, °C.	
Azerbaijan	1	Strakhtany paraffinic	0.850	150	Lower than -20	0.868	180	-6	0.890	210	-22	0.904	245	30	0.925
	2	Lubricating oil—first quality	0.871	140	..	0.884	170	Lower than -20	0.899	200	Lower than -20	0.912	215	-15	0.917	235	-3
	3	Balakhan heavy	0.900	130	..	0.915	160	..	0.903	190	..	0.940	210	Lower than -20	0.945	225	Lower than -20
	4	Bibi-Eibat light	0.890	160	..	0.900	175	..	0.910	205	..	0.925	225	..	0.935	236
	5	Bibi-Eibat heavy	0.898	150	..	0.908	168	..	0.925	198	..	0.935	220	..	0.945	230
	6	Buagady	0.900	138	..	0.918	160	..	0.937	185	..	0.942	208	..	0.946	220
	7	Arim	0.880	0.895	185	..	0.925	195	..	0.933	215	..	0.935	220
	8	Armas light	0.880	0.897	170	..	0.912	195	..	0.925	215	..	0.930	225
	9	Lok-Butan heavy	0.907	160	..	0.922	190	..	0.931	205	..	0.937	220
Gromy	10	Gromy paraffinic	0.850	158	-1	0.867	186	+23	0.890	220	-36	0.907	250	+43
	11	Gromy paraffinic-free	0.887	138	..	0.906	164	..	0.920	190	..	0.930	220	..	0.936	240
Malkop	12	Malkop	0.900	142	..	0.908	164	..	0.920	198	..	0.930	218
	13	Dosor-Makat	0.878	148	..	0.887	160	..	0.890	198	..	0.903	210
Emba	14	S. Iskine	0.855	178	..	0.863	200	..	0.871	220	..	0.875	245
	15	Surtizannak	0.890	138	-3	0.900	158	-5	0.926	196	-20	0.940	225	-28	0.950	..	-30
Turkmenian	16	Nebhidag	0.870	120	..	0.885	148	..	0.904	181	..	0.916	212	-20	0.920	221	-17
	17	Shorusu	0.880	150	-5	0.890	180	+10	0.903	220	+27	0.915	255	-30
	18	Kim	0.866	120	-3	0.878	178	+15	0.900	220	+23	0.915	248	+23	0.930	260
Sakhalin	19	Okhs 3 Layer	0.910	140	Lower than -20	0.930	160	Lower than -20	0.945	178	..	0.955	192	-20	0.958	200	-10
	20	" 7 Layer	0.895	150	..	0.907	168	-10	0.930	190	-1	0.910	208	+6	0.965	215	-10
	21	" 11-15 Layers	0.885	150	-9	0.900	170	+10	0.910	194	+20	0.934	228	+28	0.940	224	-30

ROUMANIA

By R. J. FORBES, M.N.R.I.E.

Chemical Engineer, Amsterdam Laboratory, Bataafsche Petroleum Maatschappij

THE history of the oil industry of Roumania goes back for many centuries. For many hundreds of years oil seepages were locally known and exploited. This is clearly evidenced in old travellers' tales such as those of Brandinus (1646), Reicevich (1750), and Demidoff (1837), to mention only the most important in various periods. The way the oil was drawn from these wells was as primitive as possible. There were usually shafts dug by hand and lined with boards. The oil thus obtained was used as fuel, for lighting the dwellings of the boyars, and frequently also as cart-grease. The birth of the modern oil industry there may be

spur of the Carpathians. Along the extreme southern edge of the Carpathians in west Roumania no traces of oil have been found as yet, while the area within the 'hoof' of the Carpathians, Transylvania, according to many prospectors' reports, only has rich gasfields. The geology of the oilfields was a short time ago excellently described by Macoveci [5, 1930], while a special treatise on the Roumanian petroleum industry was published by Pizanty [6, 1933]. Salt-domes play a dominant part in the structure of the Roumanian oilfields; their study is complicated by the fact that the crudes from the two flanks of an anticline may differ considerably. It is almost impossible to give sharp general characteristics of the Roumanian crudes, as against other crudes, as their properties vary so widely, and practically all known varieties and compositions of petroleum occur side by side. Nevertheless there are a few characteristics that have exerted a certain influence on the development of Roumanian refining methods:

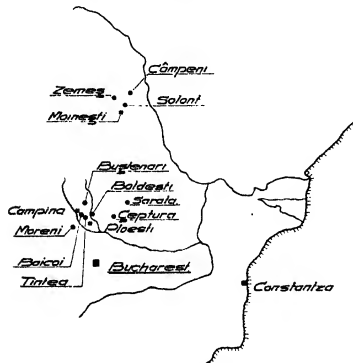

The oilfields of Roumania.

said to date some years before that in America. It may be reckoned to commence with the building of the first refinery in Ploesti in 1856. As early as in 1857 we find the first mention of the total oil production, viz. 257 tons, an amount that must certainly have been affected by the introduction of oil-lamps for illuminating the streets of Bukarest in the same year. This production must have been collected by means of the simple hand-made shafts, as drilling was first applied in 1864. The industry then grew apace and soon occupied the most important position in Europe, next to Russia. If the production in 1897 amounted to as much as over 100,000 tons, in 1907 it was already 1,150,000 tons, in 1931 6,658,000 tons. At the present day Roumania occupies the fourth place in the world production with 7,376,000 tons (1933), while it produces 3.7% of the annual total world production [7, 1933; 9]; the resources now known to geologists are estimated by Dewhurst at 500,000,000 bbl. [3, 1934].

The Roumanian fields must be regarded as a continuation of the Galician oilfields, situated as they are on the eastern

(1) Generally speaking, the crudes from the different fields belong to the types poor in sulphur. From the numerous data in the handbooks it may be implied that this content seldom amounts to more than 0.4% calculated on the crude oil.

(2) Another characteristic is their high content of light volatile aromatic hydrocarbons. Though this need not be looked upon as a drawback for the gasoline fractions, yet for the kerosine fraction, in which this percentage varies between 15 and 25, even cases of 35% are known, it constitutes an objectionable feature which these kerosines share with those from Borneo. It is therefore logical that in order to make them suitable for the market, where they must compete with the American and Russian kerosines, special refining methods were developed. Edeleanu succeeded in finding an efficacious and economical solution of the problem by extracting the fractions with liquid sulphur dioxide, a method that was also applied with success in Borneo and is nowadays even used in refining lubricating oils and gasolines.

(3) The Roumanian crudes have not only a high naphthene content, but also a considerable percentage of naphthenic acids, which is high particularly in the case of the geologically younger crudes. In these crudes, acid values of the magnitude of 5 sometimes occur. It goes without saying that these compounds are very undesirable in most petroleum products. In the kerosine the percentage is generally negligible, and refining need not be adapted in any special way. But the lubricating-oil fractions contain such large quantities that it is necessary to eliminate them, not only for the sake of refining the oil, but also to avoid considerable corrosion of the apparatus. Usually this is effected by distilling the crude oil or a lubricating-oil cut 'over lye', i.e. feeding a certain amount of lye together with the intake to the heater or still, thus fixing the acids as naphthenates. This again entails fresh difficulties, as it gives the residue a high ash content, which may be a drawback in its application as fuel or bitumen.

(4) Finally, it must be observed that the Roumanian waxy crudes frequently contain a very high content of paraffin wax,

which usually varies from 4.5 to 6.5%, sometimes even reaching 10%. In some cases, as in a seepage near Predeal, the crude oil is so rich in paraffin wax that it resembles crude vaseline. Generally, these high percentages of paraffin wax occur together with a high content of light fractions containing a high percentage of aromatics, also in oils with a low specific gravity.

In view of the brevity of this survey it is impossible to deal fully with all the Roumanian crudes here. In any case this could not be done completely as the oilfields are exploited by so many different companies that few reliable complete statistics are published. Of recent years some excellent publications have appeared by Macovei [5, 1930] and Dainaila [2, 1928], from which are derived the data for Table I. In this table are given the yields of the different fractions produced from the crudes of the various oilfields, while a few analyses of the light fractions of those oils, derived from Dainaila's figures, are also inserted. The crudes are roughly divided into asphaltic, mixed base, and waxy crudes; for want of more accurate data on the residues (after topping) this division must of necessity be only approximate. Anyhow, it may be seen that the properties of the oils of each field are liable to fluctuate considerably. Even in one field different crudes are obtained from two wells of the same depth.

In 1927, it appears that of a total production of 3,370,000 tons, Moreni alone supplied 1,416,000 tons, then comes Gura Ocnitu with 609,000, Ochiuri with 399,000, and Buştenari (Gropa) with 217,000 tons. Although this quantity has gone down a little in the last few years, one may safely assume that Moreni alone still supplies a third of the total production of the Roumanian oilfields. An extensive study on the crudes of this field has been published by Casimir [1, 1930]. The general composition as regards the fractions is shown in Table II by the side of the figures referring to the total Roumanian production.

For some crudes from the Moreni-Bana territory the Dacian crudes are free from paraffin wax, the oils from the Meotic formations of Moreni containing from 3 to 7.5% of paraffin wax. It is also clearly evident that there are striking differences between the crudes of the north and south flank of the anticline.

Casimir's investigation showed:

(1) That the content of organic acids (naphthenic acids) decreases as the stratum of oil is deeper. Only the waxy crudes from north Moreni make an exception (acid value 1.3).

(2) Both the asphalt and the sulphur content decrease as the oil is deeper, but the Meotic waxy crudes contain very little sulphur.

(3) The nitrogen content goes down in the same way, and is again for the waxy crudes lower than for the asphaltic type.

(4) All the oils are poor in olefines; determinations by Tausz's method pointed to a content that fluctuated between 0 and 1%.

(5) Although there would appear to be some relation between geological age and the aromatic content of the gasoline fraction, yet this figure is fairly constant, being 8.5-10.1%.

(6) The lightest fractions show little difference apart from a content of 33% of naphthenes in fractions of the Dacian crudes to 27% in those of the Meotic crudes.

(7) The distillates from the topped crude are distinguished by a very high acid value, higher than in oils from other fields. The lightest lubricating-oil fractions have an acid value of 7; this figure is 5 for the crude motor oils, 2.5 for the heavy lubricants, and 0.4 for the cylinder oil distillates. Owing to the formation of naphthenic soaps, the wet method of refining would lead to bad losses, while dry refining would also present difficulties. For this reason the lubricating-oil cut is neutralized with lye or lime before redistillation. That the distillates obtained after this treatment meet all the demands made of a good lubricant is amply proved by Table IV, which gives the base material and the lubricants obtained therefrom.

Finally, in Table III some data are given on crudes from fields that have been developed in recent years, which will be dealt with in brief.

From the Moreni field referred to above, analyses of two crudes have been inserted here, of which III represents a real non-waxy, asphaltic crude, and IV a typical waxy crude. The non-waxy crude is derived from a Dacian sand formation, while the waxy crude is produced by a Meotic sand.

A light waxy crude from Rasvad (VI) very much resembles the waxy crude from Moreni, apart from a higher percentage of light fractions and a lower aromatic content of these fractions.

On the other hand, the non-waxy crude from Piscuri (V) is exactly the same as that from Moreni (III), but it has more light fractions and a slightly higher asphalt content. These oils are derived from the same strata as the corresponding Moreni crudes.

The Boldesti crude (I) is produced by Meotic formations of the Pliocene Age. It greatly resembles the waxy Moreni crude, but contains somewhat more paraffin wax.

The Ceptura (II) crude also comes from Meotic sands of the Pliocene Age and is also a waxy crude, which, just as the former, has a lower aromatic content of the light fractions than the corresponding waxy Moreni crude, but otherwise resembles it in every respect. The pools in Boldesti and Piscuri were discovered in 1929, those in Rasvad in 1933.

TABLE II
The Crude Oils of Moreni (Roumania)

	Non-waxy crudes, S. flank			Non-waxy crudes, N. flank	Waxy crudes, S. flank	Waxy crudes, N. flank		Average Rumanian production
	Heavy		Light			Heavy	Light	
Sp. gr. at 15° C.	> 0.880	0.850-0.880	< 0.850	> 0.820	0.825-0.836	> 0.835	< 0.825	..
Gasoline, %	6-12	16-20	23	38-40	22	15	22	18-23
Kerosine + gas oil, %	19-25	25-28	25-28	..	37	42	45	20-82* 12-01†
Residue	62-71	52-57	48	22-32	40	40	30	46-48

White spirit plus kerosine.

† Diesel fuel, lubricating-oils + paraffin wax.

TABLE III
Roumania

Crude	Bolesti	Ceptura	Moreni	Bana	Piscuri	Rasvad
	I	II	III	IV	V	VI
Sp. gr. at 15°/4° C.	0.847	0.858	0.900	0.850	0.880	0.848
Yields:						
Gasoline, % by wt.	21.6	20.1	22.7	23.0	28.5	26.1
Kerosine, " "	9.6	10.7	8.4	10.0	13.7	10.8
Gas oil, " "	16.6	18.8	4.3	15.9	4.6	16.8
Residue (including loss)	52.2	50.4	64.6	51.1	53.2	46.3
	100.0%	100.0%	100.0%	100.0%	100.0%	100.0%
Gasoline:						
Sp. gr. at 15°/4° C.	0.738	0.739	0.762	0.757	0.760	0.740
Sulphur content	0.02%	0.02%	0.01%	0.01%	0.02%	0.01%
Initial boiling-point, °C	43	45	48	57	46	49
Final " "	172	173	176	193	175	175
Distilling up to 100° C.	29.5%	28.0%	21.0%	19.0%	26.0%	29.0%
Kerosine:						
Sp. gr. at 15°/4° C.	0.802	0.804	0.847	0.808	0.848	0.806
Sulphur content	0.21%	0.19%	0.22%	0.18%	0.23%	0.20%
Initial boiling-point, °C	158	161	158	165	163	165
Distilling up to 200° C.	41%	40%	41%	40%	42%	40%
" " 280° C.	93%	93%	93%	93%	93%	93%
Gas oil:						
Sp. gr. at 15°/4° C.	0.831	0.835	0.873	0.835	0.889	0.834
Sulphur content	0.24%	0.25%	0.22%	0.20%	0.26%	0.21%
Initial boiling-point, °C	207	217	218	220	214	220
Distilling up to 300° C.	73%	71%	80%	71%	87%	74%
Pour-point, °C.	+2	+5	..	+2	..	-1
Residue:						
Sp. gr. at 15°/4° C.	0.916	0.910	0.968	0.915	0.962	0.912
Sulphur content
Viscosity, °E/50° C.	13.4	8.8	23.0	12.2	24.3	8.8
Pour-point, °C.	+41	+41	-16	+38	-12	+35

TABLE IV

Products obtained from Distillation of Moreni Asphaltic Crude Residue

Residue	Gas oil	Light Lub. Oil Dist.	Cyl. Oil Dist.
Sp. gr. at 15°/4° C.	0.970	0.918	0.950
Flash-point Marc.	168° C.	2.0	4.5
Visc. °E/50° C.	67	99° C.	183° C.
Pour-point	-7° C.	-30° C.	-28° C.
Yields			
Gas oil, % by wt.	12.3	0.937	0.960
Spindle Oil	4.9	6.5	17.5
Light Lub. Oil Dist.	11.6	152° C.	218° C.
Medium Lub. Oil Dist.	13.3	< -30° C.	15° C.
Cylinder Oil Dist.	11.3		
Asphalt (incl. loss)	46.6		

REFERENCES

- CASIMIR, E. E., CREANGA, C., and DIMITRIU, M. *Petr. Z.*, **26**, 617-22 (1930).
- DINAILEA, N., and STOENESCU, V. *Petr. Z.*, **24**, 1303-9 (1928).
- DRYHURST, T. *J.I.P.T.* **20**, 281 (1934).
- ELIAS, G. *J.I.P.T.* **20**, 509-99 (1934).
- MACOVEI, G. Rumänien, die Erdöl-, Gas- und Asphaltlagerstätten. In *Engler-Höfer*, **2**, pt. 2, 2nd ed. (1930).
- PIZANY, M. *Le Pétrole en Roumanie*. Bukarest, 1933, 384 pp.
- SELL, G. *J.I.P.T.* **19**, 673 (1933).
- SEVERIN, E. *Petr. Z.*, **24**, no. 28, 13-16 (1933).
- STEFANESCU, N. N. *Oil Weekly*, **73**, no. 9, 165, 14/5.
- WOODROW, W. A. *J.I.P.T.* **13**, 398 (1927-8).

POLAND

By Chem. Eng. J. EHRlich and Dr. A. SZAYNA
The Technical University, Lwow, Poland

DURING the years 1929-32 a series of analyses were carried out on crude oils obtained from every region of Poland.

All work was carried out with an arranged system and using standardized analytical methods, in order that the chemical and physical properties of these oils might be comparable.

In the first part of this work analyses of the following oils will be found.

A. Paraffin Wax-free Oils

No.	Place of origin	Mark	Name of well	Firm
1	Potok	Potok	No. 144	'Malopolska'
2	Grabownica-Humnisko	Grabownica	" 5	'Soc. Petr. de Grabown'
3	Krościenko-Nizne	Krościenko (Paraffin-free)	" 43	'Malopolska'
4	Węglówka	Węglówka	" 114	"
B. Oils containing Paraffin Wax				
5	Boryslaw	Boryslaw	Konrad IV	'Malopolska'
6	Bitków	Bitków	No. 45	"
7	Schodnica	Schodnica	'Ferdynand'	'Gazy Ziemi'

In the second part of this work analyses of the following special oils are given.

A. Paraffin Wax-free Oils

No.	Place of origin	Mark	Name of well	Firm
1	Mokre	Mokre	'Stefan'	H. Stiefl
2	Harkłowa	Harkłowa-Ropita	'Ropita'	'Ropita' Petrol. Comp.
3	Biecz	Biecz-Jedność	'Jedność'	'Jedność' Petr. Gesel.
4	"	Biecz-Romania	'Romania'	'Horta'
5	Korczyzna	Biecz-Zalawie	'Stanislaw'	Wl. Długosz
6	Kosmacz	Kosmacz	Kosmaczka Ropa and Premier	Kosmaczka Storch and Comp.
7	Rudawka-Rymanowska	Rymanów	Opek 1	L. Hirschfeld
8	Majdan	Majdan-Rostulna	'Anna'	W. Zackerberg
9	Potok	Potok	'Józef'	'Józef' Petr. Comp.

B. Oils containing Paraffin Wax

10	Grabownica-Humnisko	Grabownica (containing paraffin)	..	Soc. de Petr. de Grabownica
11	Kryg	Kryg (black)	..	'Kryg' Petr. Comp.
12	"	Kryg (green)	..	"
13	Libusza	Libusza	'Adam'	'Libusza' Petr. Comp.
14	Lipinki	Lipinki	'Jakób, Elzbieta Nagroda, Jutrzenka, Henryk'	'Faworyt' Petr. Comp.
15	Schodnica	Schodnica-Pilon	'Pilon'	'Pilon'

No.	Place of origin	Mark	Name of well	Firm
16	Wójtowa	Wójtowa	Ropita	'Ropita' Petr. Comp.
17	Stara Wieś	Stara Wieś	Starow-sianka	I. T. Buchwald
18	Słoboda-Rungur	Słoboda-Rungur
19	Bitków	Bitków (Stella-Zofia)	'Stella, Zofia'	Oil Comp.

Analytical Methods

The water and solids in the oils were determined by centrifuging, and the specific gravity at 15° C. was determined with a pycnometer. The freezing-point was determined in a 25-mm. diameter tube, and for viscosity readings an Engler viscometer was used.

The flash-points of the benzene residue and petroleum were determined in a Pensky Marten apparatus; the open flash being determined for oils by Marcusson's method.

The softening-point of asphalt was determined according to the method of Krämer-Sarnow, and hard asphalt was determined, normal gasoline being used. The paraffin wax content was determined by Engler-Holde's method.

For the Refractive Index, the Abbé refractometer was used, and the acidity or acid number of the oil was determined by Holde's method.

The usual apparatus was employed for the Engler distillation, and the ultimate analysis for carbon and hydrogen determination was carried out by Liebig's method.

A bomb calorimeter was used to determine the sulphur content.

The chemical analysis of the petroleum spirit was made by an absorption method, the unsaturated hydrocarbons being removed with 86% sulphuric acid, and the aromatic hydrocarbons with 100% sulphuric acid. On the petroleum spirit thus freed from unsaturated and aromatic hydrocarbons, an aniline-point determination was made, and hence the percentage of naphthenic and paraffinic hydrocarbons found.

The laboratory distillation of oil with super-heated steam and under atmospheric pressure was carried out in an iron distillation vessel of 10 litres capacity. Crude spirit distilled up to 220° C., without using steam, but later by using steam oil distillates were obtained. In order to avoid cracking of the heavy oil the quantity of steam was increased until the condensed water amounted to 50% of the oil distillate and a petroleum fraction up to the specific gravity of 0.850 was collected. The distillation was continued until a red resinous substance passed over; the heat under the distilling vessel being then cut off and steam blown through for 10 min. In this way fractions were obtained which did not always correspond to refinery products, but nevertheless the method enabled a comparison to be made of the properties of various oils.

Fractionation of the crude spirit was carried out, using a five-bulb Ganz-Glinski column, a single fraction to 180° C. being collected.

Experimental

In the following tables the physical and chemical properties of all the oils analysed are given.

Oils from Potok

Depth of well	803.19 yds.
Geological formation	Eocene
Content of water and suspended solid material (of the oil separated from emulsifying water)	0.0%

Properties of Dry Oil

Density (15° C.)	0.8220
Freezing-point	-18° C.
Viscosity, E ₂₀	1.15
Hard asphalt	0.017%
Paraffin wax content	0.23%
Sulphur content	0.09%
Acidity (calculated as acid no.)	1.081
" " as SO ₂ %	0.077%
" " as oleic acid	0.519%

First Engler Distillation (100 c.c. of oil)

I.B.P.	38°/47° C.
% distilled to 150° C.	36.5
Density (15° C.), fraction to 150° C.	0.734
% distilled 150-300° C.	34.6
Density (15° C.), fraction 150-300° C.	0.816
Residue above 300° C.	27.3 g.
Density (15° C.) of residue	0.9392
Freezing-point of residue above 300° C.	18° C.

Second Engler Distillation (100 c.c. of oil)

I.B.P.	35°/46° C.
To 80° C. % distilled	4.0
" 100 " "	12.0
" 120 " "	22.4
" 150 " "	36.4
" 180 " "	45.3
" 200 " "	49.8
" 220 " "	54.9
Density (15° C.), fraction to 220° C.	0.7544
Residue above 220° C.	40.4 g.

Properties of Residue above 220° C.

Density (15° C.)	0.9106
C	86.32%
H	12.24%
S	0.24%

Distillation in a 10-litre Vessel using Superheated Steam

Yield on crude (% by weight):	%
Crude spirit to 220° C.	0.7582
Kerosine (heavy)	0.8486
Oil	0.8640 E ₂₀ : 1.42
" "	0.8755 E ₂₀ : 1.79
" "	0.8976 E ₂₀ : 3.71
" "	0.9260 E ₂₀ : 4.48
" "	0.9461 E ₂₀ : 27.17
Asphalt, softening-point 29.5° C.	8.07
Loss	0.48

Yield and Properties of Fractionated Spirit

Boiling range	D ₁₅	% by wt. of petroleum	Refractive index at 20° C.	Flash-point
1. Up to 100° C.	0.7091	13.47	1.3962	..
2. 100-120° C.	0.7419	11.57	1.4135	..
3. 120-135° C.	0.7573	5.84	1.4219	..
4. 135-150° C.	0.7657	5.45	1.4269	..
5. 150-165° C.	0.7743	4.08	1.4318	..
6. 165-180° C.	0.7801	3.81	1.4369	..
Residue above 180° C.	0.8269	10.16	1.4594	69° C.
Distillation loss	..	0.17

Total Spirit Distilled up to 180° C.

% wt. calculated on petroleum	44.22
Density (15° C.)	0.7442
% olefines	0
% aromatic hydrocarbons	10
Aniline point (after absorption of olefines and aromatic hydrocarbons)	60.9° C.
From the aniline point calculated on the primary spirit:	
% naphthene hydrocarbons	27
% paraffin	63

Properties of Petroleum, Oil, and Residues

Product	D ₁₅	% by wt. of petroleum	Viscosity	Freezing-point	Flash-point	Remarks
1 Gasoline residue	0.8269	10.16	M.P. 69° C.	n _D ²⁰ = 1.4594
2 Heavy kerosene	0.8486	6.69	77° C.	fluid
3 Oil	0.8640	5.37	E ₂₀ : 1.42	-18° C.	110° C.	..
4. "	0.8755	3.74	E ₂₀ : 1.79	..	131° C.	..
5. "	0.8976	7.14	E ₂₀ : 3.71	..	152° C.	..
6. "	0.9260	7.92	E ₂₀ : 4.48	..	203° C.	..
7. "	0.9461	6.04	E ₂₀ : 27.17	-4° C.	211° C.	..
8. Asphalt Softening-point	..	8.07
..	29.5° C.

Yield

Product	D ₁₅	% of petroleum
Gasoline to 100° C.	0.7091	13.47
" 100-120° C.	0.7419	11.57
" 120-135° C.	0.7573	5.84
" 135-150° C.	0.7657	5.45
" 150-165° C.	0.7743	4.08
" 165-180° C.	0.7801	3.81
Total gasoline to 180° C.	..	44.22
" kerosene	..	16.85
Gas oil	0.8640 E ₂₀ : 1.42	5.37
" "	0.8755 E ₂₀ : 1.79	3.74
Spindle oil	0.8976 E ₂₀ : 3.71	7.14
Machine oil	0.9260 E ₂₀ : 4.48	7.92
" "	0.9461 E ₂₀ : 27.17	6.04
Asphalt, softening-point	29.5°	8.07
Loss	..	0.65

Oil from Grabownica

Depth of well	617 yds.
Geological formation	Chalk.
Production per day	939 gal.
Content of water and impurities in the oil separated from emulsifying water	0.0%

Properties of Water-free Oil

Density (15° C.)	0.8224
Freezing-point	-20° C.
Viscosity, E ₂₀	1.20
Hard asphalt	0.00%
Paraffin wax content	0.24%
Sulphur content	0.08%
Acidity (calculated as acid no.)	0.947
" " as SO ₂ %	0.068%
" " as oleic acid	0.473%

First Engler Distillation (100 c.c. of oil)

I.B.P.	40°/54° C.
% distilled to 150° C.	28.8
" 150-300° C.	37.1
Residue above 300° C.	30.15 g.
Density (15° C.), fraction to 150° C.	0.732
" " " 150-300° C.	0.8134
" " " residue above 300° C.	0.9176 g.
Freezing-point of residue above 300° C.	-20° C.

Second Engler Distillation (100 c.c. of oil)		
I.B.P.		41°/53° C.
To 80° C. % distilled		2.4 c.c.
" 100 "		8.2 "
" 120 "		16.8 "
" 150 "		28.4 "
" 180 "		38.1 "
" 200 "		43.7 "
" 220 "		48.8 "
Density (15° C.), fraction to 220° C.		0.7558
Residue above 220° C.		44.3 g.

Properties of Residue above 220° C.	
Density (15° C.)	0.8903
Hard asphalt	0.00%
C	86.87%
H	12.66%
S	0.12%

Distillation in a 10-litre Vessel using Superheated Steam		
Yield on crude (% by weight):		
Crude spirit to 220° C.	0.7580	48.49
Kerosine	0.8341	4.86
heavy	0.8477	4.87
Gas oil	0.8615 E ₁₈	5.60
" "	0.8742 E ₁₈	5.11
Spindle oil—distillate	0.8890 E ₁₈	3.53
Machine oil—distillate light	0.9045 E ₁₈	10.62
" "	0.9205 E ₁₈	6.94
Motor oil	0.9310 E ₁₈	18.97
Residue	0.9578 E ₁₀₀	11.69
Distillation loss		0.74

Yield and Properties of Fractionated Spirit

Boiling range	D ₁₅	% calculated on oil	Refractive index at 20° C. n _D	Flash-point
1. Up to 100° C.	0.7038	10.26	1.3940	..
2. 100–110° C.	0.7362	4.29	1.4104	..
3. 110–120° C.	0.7461	3.66	1.4156	..
4. 120–135° C.	0.7555	5.19	1.4207	..
5. 135–150° C.	0.7640	5.19	1.4257	..
6. 150–165° C.	0.7730	3.64	1.4307	..
7. 165–180° C.	0.7810	4.23	1.4350	..
Spirit residue above 180° C.	0.8165	11.73	1.4523	62° C.
Fractionating loss		0.30

Total Spirit Distilled to 180° C.

% wt. calculated on oil	36.46
Density (15° C.)	0.7432
Content unsaturated hydrocarbons	0%
aromatic	7.5%
Aniline point (after absorption of olefines and unsaturated hydrocarbons)	61.2° C.
From aniline point calculated on primary spirit:	
% naphthenic hydrocarbons	27
% paraffin hydrocarbons	65.5

Properties of Kerosine, Oil, and Residue

Product	D ₁₅	% by wt. on oil	Viscosity	Freezing-point	Flash-point	Remarks
1. Spirit residue	0.8165	11.73	62° C.	..
2. Kerosine	0.8341	4.86	69° C.	..
3. " heavy	0.8477	4.87	86° C.	..
4. Gas oil	0.8615	5.60	E ₁₈ : 1.45	-18° C.	112° C.	..
5. " "	0.8742	5.11	E ₁₈ : 1.97	-18° C.	132° C.	..
6. Spindle oil—distillate	0.8890	4.90	E ₁₈ : 3.53	..	159° C.	..
7. " "	0.9045	6.93	E ₁₈ : 10.62	..	185° C.	..
8. Machine oil—distillate	0.9205	5.67	E ₁₈ : 6.94	..	219° C.	..
9. Motor oil	0.9310	4.29	E ₁₈ : 18.97	-15° C.	248° C.	..
10. Residue	0.9578	8.58	E ₁₀₀ : 11.69	+12° C.	318° C.	..
Hard asphalt						0.00%

		Yield	
Product	D ₁₅	% on crude oil	
Gasoline to 100° C.	0.7038	10.26	
" 100–110° C.	0.7362	4.29	
" 110–120° C.	0.7461	3.66	
" 120–135° C.	0.7555	5.19	
" 135–150° C.	0.7640	5.19	
" 150–165° C.	0.7730	3.64	
" 165–180° C.	0.7810	4.23	
Total gasoline to 180° C.	0.7432	36.46	
Gasoline residues	0.8165	11.73	
Kerosine	0.8341	4.86	
Heavy kerosine	0.8477	4.87	
Total kerosine	..	21.46	
Gas oil	0.8615 E ₁₈	1.45	5.60
" "	0.8742 E ₁₈	1.97	5.11
" "	0.8890 E ₁₈	3.53	4.90
" "	0.9045 E ₁₈	10.62	6.93
Machine oil	0.9205 E ₁₈	6.94	5.67
Automobile oil	0.9310 E ₁₈	18.97	4.29
Residue	0.9578 E ₁₀₀	11.69	8.58
Loss			1.04

Oil from Krościenko Niżne

Depth of well	566.5 yds.
Geologic formation	Eocene
Production per day	750 gal.
Content of water and suspended solid material in the crude separated from emulsifying water	0.0%

Properties of Dry Oil

Density (15° C.)	0.8828
Freezing-point	-18° C. fluid
Viscosity, E ₁₈	2.08
Hard asphalt	0.033%
Paraffin wax content	0.35%
Sulphur content	0.09%
Acidity (calculated as acid no.)	2.91
" " as SO ₂ %	0.208%
" " as oleic acid	1.455%

First Engler Distillation (100 c.c. of oil)

I.B.P.	49°/73° C.
" distilled to 150° C.	11.5
Density (15° C.), fraction to 150° C.	0.7571
% distilled 150–300° C.	34.5
Density (15° C.), fraction 150–300° C.	0.8390
Residue above 300° C.	50.1 g.
Density (15° C.) of residue above 300° C.	0.9430
Freezing-point of residue above 300° C.	18° C.

Second Engler Distillation (100 c.c. of oil)

I.B.P.	52°/73° C.
To 80° C. % distilled	0.1
" 100 "	2.1
" 120 "	5.4
" 150 "	17.4
" 180 "	17.6
" 200 "	21.2
" 220 "	26.2
Density (15° C.), fraction to 220° C.	0.7880
Residue above 220° C.	66.8 g.

Distillation in a 10-litre Vessel using Superheated Steam

Yield on crude (% by weight):		%
Crude spirit to 210° C.	0.7866	23.70
Heavy kerosine	0.8522	11.07
Oil	0.8728	8.22
" "	0.8851	5.97
" "	0.8968	5.36
" "	0.9099	5.59
" "	0.9203	5.55
" "	0.9351	8.79
" "	0.9467	6.16
Residue		19.24
Softening-point of residue		8° C.
Loss		0.35%

Properties of Residue above 220° C.

Density (15° C.)	0.9238
C	87.02%
H	12.10%
S	0.19%

Yield and Properties of Fractionated Gasoline

Boiling range	D ₁₅	% by wt. on crude	Refractive index at 20° C.
1. Up to 100° C.	0.7361	4.32	1.4108
2. 100-110° C.	0.7693	1.15	1.4285
3. 110-120° C.	0.7750	1.63	1.4323
4. 120-135° C.	0.7821	3.80	1.4367
5. 135-150° C.	0.7889	2.63	1.4406
6. 150-165° C.	0.7929	1.45	1.4425
7. 165-180° C.	0.7974	1.54	1.4443
Residue above 180° C.	0.8328	6.98	1.4628
Distillation loss	..	0.20	..

Total Spirit Distilled up to 180° C.

% wt. calculated on crude petroleum	16.52
Density (15° C.)	0.7715
% olefines	1
% aromatic hydrocarbons	21
Aniline point (after absorption of olefines and aromatic hydrocarbons)	56° C.
From aniline point calculated on the primary spirit:	
% naphthene hydrocarbons	36.5
% paraffin hydrocarbons	42.0

Properties of Kerosine, Oils, and Residue

Product	D ₁₅	% by wt. on crude	Viscosity	Freezing-point	Flash-point	Remarks
1. Kerosine	0.8522	11.07	M P 69° C.	..
2. Oil	0.8728	8.22	E ₂₀ : 1.40	-18° C.	107° C.	..
3. "	0.8851	5.97	E ₂₀ : 1.77	..	129° C.	..
4. "	0.8968	5.36	E ₂₀ : 2.64	..	151° C.	..
5. "	0.9099	5.59	E ₂₀ : 5.69	..	170° C.	..
6. "	0.9203	5.55	E ₂₀ : 15.96 and E ₃₀ : 3.24	..	188° C.	..
7. "	0.9315	8.79	E ₂₀ : 7.94	..	211° C.	..
8. "	0.9467	6.16	E ₂₀ : 21.98	-12° C.	247° C.	..
9 Asphalt residue	..	19.24
Softening-point	8° C.

Yield

Product	D ₁₅	% on crude petroleum
Gasoline to 100° C.	0.7361	4.32
" 100-110° C.	0.7693	1.15
" 110-120° C.	0.7750	1.63
" 120-135° C.	0.7821	3.80
" 135-150° C.	0.7889	2.63
" 150-165° C.	0.7929	1.45
" 165-180° C.	0.7974	1.54
Total gasoline to 180°	..	16.52
Kerosine (gasoline residues)	0.8328	6.98
Heavy kerosine	0.8522	11.07
Total kerosine	..	18.05
Oil	0.8728 E ₂₀ : 1.40	8.22
"	0.8851 E ₂₀ : 1.77	5.97
"	0.8968 E ₂₀ : 2.64	5.36
"	0.9099 E ₂₀ : 5.69	5.59
"	0.9203 E ₂₀ : 3.24	5.55
"	0.9315 E ₂₀ : 7.94	8.79
"	0.9467 E ₂₀ : 21.98	6.16
Residue	..	19.24
Loss	..	0.55

Oil from Weglówka

Depth of Well	492 yds.
Geological formation	Sandstone
Production per day	328.7 gal.
Content of water and suspended solid material in the crude separated from emulsifying water	0.0%

Properties of Dry Oil

Density (15° C.)	0.8670
Freezing-point	-18° C. fluid
Viscosity, F ₂₀	1.61
Hard asphalt	0.070%
Paraffin wax content	0.44%
Sulphur	0.13%
Acidity (calculated as acid no.)	1.099
" " as SO ₃ %	0.078%
" " as oleic acid	0.549%

First Engler Distillation (100 c.c. of oil)

I.B.P.	39°/51° C.
" distilled to 150° C.	24.7
Density (15° C.), fraction to 150° C.	0.7294
" of 150-300° C., fraction	29.2
Density (15° C.), fraction 150-300° C.	0.8328
Residue above 300° C.	43.8
Density (15° C.), residue above 300° C.	0.9664
Freezing-point of residue above 300° C.	11° C.

Second Engler Distillation (100 c.c. of oil)

I.B.P.	37°/49° C.
To 80° C. % distilled	3.7
" 100 " "	8.4
" 120 " "	15.1
" 150 " "	25.0
" 180 " "	31.7
" 200 " "	35.7
" 220 " "	40.4
Density (15° C.), fraction to 220° C.	0.7572
Residue over 220° C.	55.3 g.

Properties of Residue above 220° C.

Density (15° C.)	0.9416
C	87.05%
H	11.34%
S	0.29%

Distillation in a 10-litre Vessel using Superheated Steam

Yield of residue (% by weight):	
Crude spirit to 220° C.	36.11
Oil	6.31
"	5.21
"	4.68
"	4.36
"	5.43
"	7.52
"	6.28
"	8.28
Asphalt	15.46
Softening-point of asphalt	38.5° C.
Loss	0.36

Yield and Properties of Fractionated Spirit

Boiling-range	D ₁₅	% by wt. on crude petroleum	Refractive index at 20° C.	Flash-point
1. Up to 100° C.	0.6897	8.26	1.3862	..
2. 100-120° C.	0.7437	7.49	1.4121	..
3. 120-135° C.	0.7595	4.34	1.4205	..
4. 135-150° C.	0.7702	4.05	1.4267	..
5. 150-165° C.	0.7841	2.30	1.4339	..
6. 165-180° C.	0.8011	2.33	1.4432	..
Spirit residue above 180	0.8409	7.13	..	61° C.
Distillation loss	..	0.21

NATURE OF CRUDE PETROLEUM

Total Spirit Distilled up to 180° C.

% by wt. calculated on petroleum	28.77
Density (15° C.)	0.7409
% olefines	0
% aromatic hydrocarbons	3
Aniline point (after absorption of olefines and aromatic hydrocarbons)	56.7° C.
From aniline point calculated on primary spirit:	
% paraffin hydrocarbons	54
% naphthene hydrocarbons	43

First Engler Distillation (100 c.c. of oil)

I.B.P.	35°/41° C.
% distilled to 150° C.	27.8
Density (15° C.), fraction to 150° C.	0.7257
% distilled 150-300° C.	32.9
Density (15° C.), fraction 150-300° C.	0.8225
Residue above 300° C.	33.9 g.
Density (15° C.) of residue above 300° C.	0.925
Freezing-point of residue above 300° C.	+8.5° C.

Properties of Kerosine, Oil, and Residues

Product	D ₁₅	% by wt. on crude petroleum	Viscosity	Freezing-point	Flash-point	Remarks
1. Spirit	0.8409	7.13			M.P.	
residue.					61° C.	
2. Oil	0.8573	6.31	E ₁₀₀ : 1.19	-18° C.	Marcus	
3. "	0.8777	5.21	E ₁₀₀ : 1.36	"	76° C.	
4. "	0.8934	4.68	E ₁₀₀ : 1.72	"	116° C.	
5. "	0.9112	4.36	E ₁₀₀ : 2.98	"	140° C.	
6. "	0.9260	5.43	E ₁₀₀ : 9.77	"	168° C.	
7. "			E ₁₀₀ : 2.40	"		
8. "	0.9404	7.52	E ₁₀₀ : 7.01	195° C.		
9. "	0.9512	6.28	E ₁₀₀ : 25.94	-13° C.	221° C.	
9. "	0.9620	8.28	E ₁₀₀ : 73.30	+0° C.	248° C.	
10. Asphalt		15.46	E ₁₀₀ : 4.06			
Softening-point						38.5° C.

Second Engler Distillation (100 c.c. of oil)

I.B.P.	35°/41° C.
To 80° C. % distilled	6.3
" 100 " "	12.2
" 120 " "	19.2
" 150 " "	27.4
" 180 " "	34.3
" 200 " "	38.6
" 220 " "	43.7
Density (15° C.) fraction, to 220° C.	0.7488
Residue over 220° C.	48.7 g.

Properties of Residue above 220° C.

Density (15° C.)	0.900
C	86.58%
H	12.19%
S	0.21%

Distillation in a 10-litre Vessel using Superheated Steam

Yield on crude (% by weight):	%
Crude spirit to 210° C. 0.7499	41.13
Crude kerosine 0.8381	9.85
Oil	6.80
" 0.8370 E ₁₀₀ : 1.36	6.80
" 0.8755 E ₁₀₀ : 1.84	7.57
" 0.8906 E ₁₀₀ : 3.05	4.96
" 0.9080 E ₁₀₀ : 8.60	4.79
Wax distillate 0.9218 E ₁₀₀ : 6.25	13.46
Wax residue, softening-point +17° C.	10.47
Loss	0.97

Yield and Properties of Fractionated Spirit

Boiling range	D ₁₅	% by wt. on crude petroleum	Refractive index at 20° C.
1. Up to 100° C.	0.6914	11.87	1.3872
2. 100-120° C.	0.7443	6.00	1.4152
3. 120-135° C.	0.7603	4.53	1.4230
4. 135-150° C.	0.7701	4.40	1.4284
5. 150-165° C.	0.7810	2.98	1.4348
6. 165-180° C.	0.7927	2.82	1.4408
Residue above 180° C.	0.8237	7.92	1.4584
Distillation loss		0.51	

Yield

Product	D ₁₅	% on crude petroleum
Gasoline to 100° C.	0.6897	8.26
" 100-120° C.	0.7437	7.49
" 120-135° C.	0.7595	4.34
" 135-150° C.	0.7702	4.05
" 150-165° C.	0.7841	2.30
" 165-180° C.	0.8011	2.33
Total gasoline to 180° C.		28.77
Kerosine (gasoline residues)	0.8409	7.13
Oil	0.8573 E ₁₀₀ : 1.19	6.31
"	0.8777 E ₁₀₀ : 1.36	5.21
"	0.8934 E ₁₀₀ : 1.72	4.68
"	0.9112 E ₁₀₀ : 2.98	4.36
"	0.9260 E ₁₀₀ : 9.77	5.43
"	E ₁₀₀ : 2.40	
"	0.9404 E ₁₀₀ : 7.01	7.52
"	0.9512 E ₁₀₀ : 25.94	6.28
"	0.9620 E ₁₀₀ : 4.06	8.28
Asphalt, softening-point	38.5° C.	15.46
Loss		0.57

Oil from Schodnica (Schacht 'Ferdynand')

Depth of well	486.7 yds.
Geological formation	Jamnen sandstone
Production per day	556.6 gal.
Content of water and suspended matter in the crude separated from emulsifying water	0.4%

Properties of Water-free Oil

Density (15° C.)	0.8287
Freezing-point	-20° C. fluid
Viscosity, E ₁₀₀	1.22
Hard asphalt	0.034%
Paraffin wax content	49.5%
Sulphur content	0.16%
Acidity (calculated as acid no.)	0.493
" " as SO ₃ %	0.035%
" " as oleic acid	0.246%

Total Spirit Distilled up to 180° C.

% by weight	32.70
Density (15° C.)	0.7410
% olefines	0
% aromatic hydrocarbons	6.5
Aniline point (after absorption of olefines and aromatic hydrocarbons)	57.9° C.
From aniline point calculated on the primary spirit:	
% naphthene hydrocarbons	33.5%
% paraffin hydrocarbons	60%

Properties of Heavy Wax Distillate

% by weight on crude	13.46
Density (15° C.)	0.9218
Pour-point	+31° C.
Viscosity, E ₁₀₀	6.25° C.
Flash-point	228° C.
Wax content	11.23%
Melting-point of paraffin wax	52.5° C.

Properties of Kerosine, Oil, and Residue

Product	D ₁₅	% by wt. on crude	Viscosity	Melting-point	Flash-point
1. Spirit residues	0-8237	7-92
2. Kerosine	0-8381	9-85	M.P. 72° C., Marcus
3. Oil	0-8570	6-80	E ₁₀ : 1-36	-18° C.	110° C.
4. "	0-8755	7-57	E ₁₀ : 1-84	-2-5° C.	141° C.
5. "	0-8906	4-96	E ₁₀ : 3-05	+9-5° C.	161° C.
6. "	0-9080	4-79	E ₁₀ : 8-60	+12-5° C.	181° C.
7. "	0-9218	13-46	E ₁₀ : 2-12
Residue	..	10-47	E ₁₀ : 6-25	+31° C.	228° C.

Yield

Product	D ₁₅	% by wt. on crude
Gasoline to 100° C.	0-6914	11-87
" 100-120° C.	0-7443	6-00
" 120-135° C.	0-7603	4-63
" 135-150° C.	0-7701	4-40
" 150-165° C.	0-7810	2-98
" 165-180° C.	0-7927	2-82
Total gasoline to 180° C.	0-7410	32-70
Kerosine (gasoline residues)	0-8237	7-92
Crude kerosine	0-8381	9-85
Gas oil	0-8570	6-80
"	0-8755	7-57
Wax distillate	0-8906	4-96
"	0-9080	4-79
"	0-9218	13-46
Asphalt residue, softening-point	17° C.	10-47
Loss	..	1-48

Oil from Bitk6w

Depth of well	782 yds.
Geological formation	Menilit
Production per month	14,180 gal.
Water content and impurities in the crude which was separated from emulsifying water	0%

Properties of Water-free Oil

Density (15° C.)	0-8082
Freezing-point	18° C. fluid
Viscosity, E ₁₀	1-15
Hard asphalt	0%
Wax content	3-40%
Melting-point of paraffin wax	47° C.
Sulphur content	0-28%
Acidity (calculated as acid no.)	0-110
" as SO ₂ %	0-008%
" as oleic acid	0-057%

First Engler Distillation (100 c.c. of oil)

I.B.P.	42°/65° C.
% distilled to 150° C.	18-8
Density (15° C.) fraction to 150° C.	0-727
% distilled 150-300° C.	52-1
Density (15° C.), fraction 150-300° C.	0-798
Residue above 300° C.	25-65 g.
Density (15° C.) of residue above 300° C.	0-8852
Four-point of residue above 300° C.	11-5° C.

Second Engler Distillation (100 c.c. of oil)

I.B.P.	51°/61° C.
To 100° C. % distilled	3-8
" 120 " "	8-8
" 150 " "	18-9
" 180 " "	28-7
" 200 " "	36-1
" 220 " "	42-9
Density (15° C.) fraction to 220° C.	0-7554
Residue above 220° C.	47-4 g.

Properties of Residue above 220° C.

Density (15° C.)	0-8520
Asphalt	0-02%
C	85-61%
H	13-25%
S	0-48%

Distillation on a 10-litre Vessel using Superheated Steam

Yield on crude (% by weight):	
Crude spirit	0-7612
Crude kerosine	0-8194
Wax distillate	0-8636
Asphalt, softening-point	22-5° C.
Distillation loss	1-21

Yield and Properties of Fractionated Spirit

Fraction	D ₁₅	% by wt. on crude oil	Refractive index at 20° C.
1. Up to 100° C.	0-6953	6-23	1-3880
2. 100-120° C.	0-7362	6-60	1-4095
3. 120-140° C.	0-7525	5-62	1-4176
4. 140-160° C.	0-7636	5-99	1-4247
5. 160-180° C.	0-7746	6-66	1-4309
6. 180-195° C.	0-7849	2-40	1-4365
Spirit residue above 195° C.	0-8076	12-75	..
Loss	..	0-12	..
Total fractionated spirit to 195° C.	..	33-50	..

Total Spirit Distilled up to 180° C.

% by weight calculated on crude oil	31-95
Density (15° C.)	0-7434
% olefines	0
% aromatic hydrocarbons	7-5
Aniline point after absorption of olefines and aromatics	64-6° C.
From the aniline point calculated on the primary spirit:	..
% naphthene hydrocarbons	16-5
% paraffin hydrocarbons	76

The Refining of Kerosine

Spirit residue and kerosine fraction after redistillation and refining	34-03%
Density (15° C.) after refining	0-8133
Refractive index after refining	1-4508
Flash-point	80° C.
Colour (Stammer in mm.)	200
Waxy oil residue after redistillation	1-00%
Refining loss calculated on kerosine fraction	1%
" " " on total crude oil	0-35%

Properties of Wax Distillate

% by weight of crude (+ residues from redistillation of kerosine)	24-25
Density (15° C.)	0-8636
Pour-point	+22-5° C.
Viscosity, E ₁₀	1-56
Flash-point	154° C.
Wax content	11-82%
Melting-point of paraffin wax	49-5° C.

Yield

Product	D ₁₅	% by wt. on crude
Gasoline to 100° C.	0-6953	6-23
" 100-120° C.	0-7362	6-60
" 120-135° C.	0-7525	5-62
" 135-150° C.	0-7636	5-99
" 150-165° C.	0-7746	6-66
" 165-180° C.	0-7849	2-40
Total gasoline to 195° C.	..	33-50
Kerosine (gasoline residues)	0-8076	12-75
Crude kerosine	0-8194	22-63
Total kerosine—refined and redistilled	0-8133	34-03
Wax distillate (redistilled)	..	23-25
Kerosine residue together with wax distillate	..	24-25
Asphalt, softening-point	22-5° C.	6-54
Loss	..	1-68

Biecz, Bitków are rich in petroleum spirit. The spirit obtained from the oils from Biecz, Wójtowa, and Krościenko contains a large percentage of aromatic hydrocarbons, whilst in contrast to this the spirit obtained from the Węglówka, Grabownica, Libusza, Starowińska, Urycz oils is deficient in aromatic hydrocarbons.

In conclusion it can be stated that the Polish oils are of differing chemical structure, it being found that oils of a decided naphthenic character are those from Węglówka

Jaszczew, Grabownica, Potok, Schodnica, whilst those from Biecz, Wójtowa, Krościenko, are rich in aromatic hydrocarbons. Other oils both naphthenic and aromatic in character are those from Harkłowa, Równe, Urycz.

Oils both aromatic and paraffinic in character and containing a proportion of naphthenic hydrocarbons are those from Boryslaw. Oils from Pasieczna and Bitków contain a large proportion of paraffin hydrocarbons and scarcely any aromatic or naphthenic hydrocarbons.

TABLE I
The Physical and Chemical Properties of Crude Oils

	Crude oil				Fractionated gasoline													
	D ₁₅	% S	Acid no.	% Hard asphalt	Fraction 150-300° C.				Residue above 220° C.			% by wt. of crude	to 180° C.					
					D ₁₅	D ₁₆	% C	% H	D ₁₅	D ₁₆	% C		% H	% aromatic hydrocarbons	% naphthenic hydrocarbons	% paraffinic hydrocarbons	Aniline point, °C.	% of paraffin wax
Potok	0.822	0.09	1.081	0.017	0.816	0.9106	86.32	12.24	0.24	44.22	0.744	10.0	27.0	63.0	60.9	0.23
Grabownica	0.822	0.08	0.947	..	0.813	0.890	86.87	12.66	0.12	36.46	0.741	7.5	27.0	65.5	61.2	0.24
Harkłowa	0.885	0.15	0.632	0.024	0.828	0.937	86.94	12.10	0.27	18.07	0.749	6.5	36.0	57.5	58.5	0.50
Krościenko	0.883	0.09	2.910	0.033	0.839	0.924	87.02	12.10	0.19	16.52	0.772	21.0	36.5	42.0	56.0	0.35
Węglówka	0.867	0.13	1.099	0.070	0.833	0.942	87.05	11.34	0.28	28.77	0.741	3.0	43.0	54.0	56.7	0.44
Równe Rogi	0.852	0.10	1.097	0.206	0.823	0.923	87.02	11.85	0.19	33.43	0.749	12.0	29.5	58.5	59.9	0.30
Urycz	0.875	0.20	1.837	0.240	0.837	0.928	87.21	11.50	0.28	24.67	0.750	7.0	30.0	62.0	60.3	0.15
Działina	0.839	..	1.331	0.180	0.828	0.907	86.52	12.28	0.26	31.28	0.754	10.0	28.5	61.5	60.5	0.23
Schodnica	0.840	0.10	0.606	0.013	0.807	0.896	86.43	12.41	0.19	29.34	0.759	11.5	19.0	68.5	63.5	0.37
Ferdynand	0.829	0.16	0.493	0.034	0.823	0.900	86.58	12.19	0.21	32.70	0.741	6.5	33.5	60.0	57.9	2.73	49.5	49.5
Wankowa	0.848	0.29	0.120	0.020	0.814	0.897	86.73	12.27	0.43	25.90	0.746	12.0	26.0	61.5	61.1	3.35	49.0	49.0
Ryżne	0.841	0.29	0.133	0.170	0.805	0.879	86.10	12.84	0.41	22.58	0.756	6.5	22.5	70.0	62.7	4.52	49.0	49.0
Bitków 45	0.868	0.28	0.110	..	0.798	0.862	85.41	13.31	0.51	25.41	0.743	7.5	16.5	76.0	64.6	3.40	47.0	47.0
Bitków 113	0.8275	0.37	0.120	..	0.802	0.862	85.41	13.31	0.51	25.41	0.743	8.5	19.0	72.5	63.7	3.65	51.0	51.0
Chrobry 3	0.811	0.13	0.062	..	0.802	0.839	85.63	13.28	0.25	32.45	0.767	14.0	13.0	73.0	65.4	2.34	44.0	44.0
Chrobry 4	0.838	0.48	0.134	..	0.801	0.880	85.46	12.82	0.76	25.90	0.745	8.0	21.0	70.5	63.2	4.91	31.5	31.5
Bosai	0.850	0.24	0.050	0.270	0.813	0.892	86.21	12.45	0.34	20.63	0.741	12.5	25.5	61.0	61.2	8.20	48.5	48.5
Konrad	0.850	0.24	0.050	0.270	0.813	0.892	86.24	12.57	0.37	19.20	0.745	12.0	24.0	61.0	61.1	8.90	48.5	48.5
Herzfeld	0.852	0.26	0.109	0.300	0.813	0.897	86.33	12.68	0.34	20.68	0.747	13.0	24.0	62.0	61.6	9.60	48.0	48.0
Joffe V	0.8605	0.27	0.200	0.180	0.810	0.8945	86.43	12.44	0.35	17.27	0.757	14.0	24.0	61.0	61.5	9.30	48.5	48.5
Petaín	0.869	0.23	0.163	0.120	0.811	0.893	86.39	12.46	0.35	16.54	0.759	14.5	21.0	63.5	62.5	7.70	48.5	48.5

TABLE II
The Chemical and Physical Properties of Oil

	Crude oil				Fraction 200-300° C.				Fractionated gasoline to 180° C.						Melting-point of wax °C.
	D ₁₅	% S	Acid no.	% asphalt	D ₁₅	D ₁₆	% C	% H	% of crude	to 180° C.			% of paraffin wax		
										D ₁₅	D ₁₆	% aromatic hydrocarbons			
Mokre Stefan	0.803	0.16	0.116	..	0.854	0.941	86.99	11.76	51.73	0.742	11.0	0	120
Harkłowa Ropita.	0.896	0.22	0.767	0.053	0.849	0.951	13.41	0.758	9.5	0	540
Biecz-Jednost	0.832	0.12	..	0.020	0.859	46.90	0.774	27.0	0	125
Biecz-Romania	0.838	0.09	0.853	0.929	41.43	0.777	27.0	0	038
Biecz-Zalawie	0.819	0.14	0.866	0.004	0.851	0.934	86.59	11.72	55.16	0.768	26.0	0	021
Kosmacz	0.870	0.13	3.436	0.035	0.844	0.940	23.28	0.747	7.0	0	500
Rudawka Ryman-	0.834	0.13	0.140	0.001	0.844	0.928	38.64	0.756	12.0	0	300
Rosulna-Majdan	0.853	0.22	0.298	0.340	0.839	0.948	33.21	0.755	15.0	0
Potok (Józef)	0.835	0.15	0.167	..	0.837	0.940	40.28	0.753	11.0	0	290
Grabownica	0.839	0.15	0.080	0.012	0.817	0.916	86.55	13.15	22.15	0.758	10.0	5.00	5.00	50.0	50.0
Kryg (Black)	0.848	0.17	0.0826	2.000	0.832	0.927	87.01	12.30	28.29	0.747	11.5	5.310	48.0	48.0	48.0
Kryg (Green)	0.833	0.16	0.056	..	0.824	0.891	86.46	12.90	27.87	0.750	11.0	8.400	50.5	50.5	50.5
Libusza	0.870	0.30	0.1078	1.910	0.833	0.942	19.82	0.757	6.5	3.370	48.0	48.0	48.0
Lipinki	0.849	0.13	0.1652	1.440	0.829	0.928	25.81	0.744	11.0	5.460	48.0	48.0	48.0
Schodnica (Pilon)	0.837	0.17	0.0826	0.140	0.829	0.909	30.80	0.766	15.5	4.200	46.5	46.5	46.5
Wójtowa	0.827	0.16	0.056	0.083	0.826	0.908	39.71	0.774	24.0	2.700	49.0	49.0	49.0
Starowińska	0.7995	0.17	0.0728	..	0.823	0.882	86.07	12.99	38.12	0.733	6.0	4.400
Sloboda Rungurska	0.845	0.22	0.1792	0.380	0.818	0.917	23.35	0.741	11.0	3.550	48.5	48.5	48.5
Bitków (Stella-Zofja)	0.790	0.13	0.0742	0.010	0.812	51.08	0.751	11.0	2.140	43.0	43.0	43.0

EUROPE AND THE EAST

By G. EGLOFF, M.A., Ph.D.

Universal Oil Products Company

Germany

Two producing areas in Germany, one at Nienhagen and the other at Edessa, yield 10% of 400° F. end-point gasoline and 27% of 410° F. end-point gasoline. There are thirty refineries in Germany operating on crude oil; the combined daily capacity is 48,000 bbl., with three cracking a total of 6,000 bbl. per day. The analyses of the crudes are shown in Table I.

TABLE I
German Crude Oil Analyses

	Nienhagen	Edessa
Gravity, ° A.P.L.	26.6	34.5
Sulphur, %	0.5	0.3
Viscosity, Furoi, at 77° F. (sec.)	12	15
Cold test, ° F.	1.2	0.4
B.S. & W., %	1.0	1.0
Water, %	4.6	3.0
Coke, % by weight	230	140
Initial b.p., ° F.		

TABLE I (cont.)

	Nienhagen	Edessa
A.S.T.M. 100 c.c. distillation:		
% over, ° F.:		
5	300	190
10	384	248
20	497	346
30	588	440
40	640	528
50	662	607
60	674	674
70	680	698
80	688	712
90	698	724
95	718	728
End point	718	740
% over at 400° F.	10.0	..
% over at 410° F.	11.0	27.0
% over at 437° F.	13.0	29.5
% over at 572° F.	27.0	45.0

Austrian Crude Oils

Austria produces a small volume of crude oil. The refinery capacity is 8,150 bbl. per day with no cracking installations. The oil is a mixed paraffin and asphalt base. The light oil derived from three crudes ranges from 11.5 to 29.5%. The analysis of the crude is shown in Table II.

TABLE II
Austrian Crude Oil

	Göding	Baumgarten	Urmansau
Colour:			
By reflected light	dark brown-blue green fl.	dark brown-blue green fl.	dark brown-blue green fl.
By transmitted light	dark brown	dark brown	dark brown
Sp. gr. at 68° F.	0.9398	0.8950	0.8964
Sp. gr. at 59° F.	0.9428	0.8985	0.8997
Flash-point (Pensky-Martens), ° F.	231.8	185.0	118.4
Burning-point, ° F.	323.6	267.8	..
Melting-point (20 mm. tube), ° F.	-4	28.4	-4
Viscosity at 68° F.	496.8 hr. = 65.67 E.G.	66.2 hr. = 8.74 E.G.	42.9 hr. = 5.72 E.G.
Viscosity at 122° F.	67.8 hr. = 8.95 E.G.	17.8 hr. = 2.63 E.G.	14.3 hr. = 2.25 E.G.
Viscosity at 212° F.	10.5 hr. = 1.88 E.G.	5.2 hr. = 1.41 E.G.	..
Acid number	1.01	0.06	0.39
Refractive index n_D^{20} at 68° F.	1.4974	1.4845	1.4780
Optical activity	0	0	0
% ash-filtered crude	0.36	0.11	0.005
% hard asphalt	under 0.01	..	0.05
% paraffin	0.20	2.82	1.26
% sulphur	0.36	0.35	0.69
Asphalt number, % by vol.	48	45	28
Higher heat content, calories	10,476	10,583	10,662
Lower heat content, calories	9,844	9,929	9,994
% hydrogen in crude	11.74	12.06	12.37
% coke	3.48	3.17	3.29
Gasoline, %	4.0
Kerosene, %	11.5	22.0	29.5
Gas oil, %	21.5	18.5	24.0
Residue, %	67.0	59.5	45.5
Engler distillation:			
Initial b.p., ° F.	442.4	336.2	266.0
Boiling-points, ° F., %:			
284	0.2
302	1.0

TABLE II (cont.)

	Göting	Baumgarten	Urmansau
Boiling-points, °F., %:			
320	2.0
338	3.5
356	..	0.5	5.0
374	..	1.0	6.5
392	..	2.0	8.0
410	..	3.0	10.0
428	..	4.0	12.0
446	..	5.0	13.0
464	1.0	7.0	14.5
482	2.0	9.0	16.5
500	3.5	11.0	19.5
518	5.0	12.5	22.0
536	7.0	16.0	25.0
554	9.0	19.0	28.5
572	11.5	22.0	30.5
590	14.5	25.0	33.0
608	17.5	28.5	36.5
626	20.0	32.5	41.5
644	24.0	36.0	46.0
662	33.0	40.5	54.5
Residue, %	67.0	59.5	45.5
Melting-point of residue (20 mm. tube), ° F.	23.9	35.6	35.6
Paraffin content of residue, %	0.3	4.6	2.8

Czechoslovakian Crude Oils

Czechoslovakian oilfields yield two types of oil, namely, a naphthenic crude from the Miocene stratum in the Egbbell field and in the Hodonin area, and a paraffinic crude in

small quantities from the Bohuslavice, Turzovka, and Mikovd regions. There are eleven refineries having a total daily capacity of 10,225 bbl. with one refinery having a cracking capacity of 1,100 bbl. The analysis of the crude is shown in Table III.

TABLE III
Czechoslovakian Crude Oils

Source	Egbbell	Hodonin	Bohuslavice	Turzovka	Mikovd
Geol. origin	Miocene Sarmatic Str.	Miocene Medit. Str.	Eocene	Eocene	Eocene
Depth, ft.	493	1,033	295	647	185
Colour:					
In reflected light	brown-green	red-brown	green	green	black
In transmitted light	red-brown	red-brown	red like refined spindle oil	red	black
Transparency mm. (depth at which a newspaper can be read)	2	25	85	9	opaque
Gravity, ° API.	19.8	18.7	49.1	36.7	46.3
Refractive index at 20° C.	1.4979	1.4970	1.4428	1.4665	1.4661
Viscosity, Engler:					
At 20° C.	15.70	10.5	1.01	1.51	1.14
At 50° C.	3.43
At 100° C.	1.45
Flash-point:					
Open cup, ° F.	235	237	below 32	135	below 32
Pensky, ° F.	235
Fire-point, ° F.	302	302	below 32	171	below 32
Solid-point, ° F.	0 (liq.)	0 (liq.)	+5 (sol.)	56 (sol.)	0 (liq.)
Org. acids (mg. KOH 1 g. oil)	1.43	1.42	neutral	0.06	0.14
Hanna iodine number	11	13	13.5	11	8.5
Asphalt insoluble in alcohol and ether, %	0.27	0	0	0.05	1.13
Sulphur, %	0.25	0.20	0.26	0.24	..
Paraffin, %	0	0	2.3	7.9	3.6
Distillation, % by weight:					
Initial b.p., ° F.	419	410	135	280	131
To 266° F.	37 (0.7235)	..	30.5 (0.717)
266-302° F.	10 (0.760)	1 (0.779)	7.5 (0.755)
302-482° F.	3.5 (0.878)	3	29 (0.800)	29 (0.795)	23 (0.789)
482-572° F.	28.5 (0.896)	28.0	9.5 (0.849)	22 (0.836)	11 (0.828)
Residue, %	67.5 (0.953)	67.0	14 (0.887)	47 (0.868)	27 (0.888)
Proportions of residue	liq. at 5° F.	liq. at 5° F.	fire above 81° F.	fire above 79° F.	fire above 76° F.
	no paraffin	..	paraffin	paraffin	paraffin
	soft asphalt	..	16.1 %	16.7 %	1.3 %
			soft asphalt 0.03 %	soft asphalt 0.55 %	soft asphalt 3.85 %

NATURE OF CRUDE PETROLEUM

TABLE IV. Italian Crude Oils

	No. 1				No. 2						
	Crude	Spirit	200-270° C. kerosine	270-350° C. cracking stock	Residue		Crude	374° F. E.P. gasoline	Kerosine	Topped crude	Reduced crude
Yields, vol. % of crude	100.0	trace	8.0	42.0	50.0		100.0	20.4	10.6	79.1	68.6
Gravity, ° API	13.9	A	B	19.9	61.8	37.0	11.6	..
Sp. gr. at 60° F.	0.885	0.926	0.975	0.998	0.9346	0.7320	0.8398	0.9888	..
Colour, ° Saybolt	23
Cu. dish gum, mg. per 100 c.c.	7
Doctor test	neg.
Sulphur, %	2.27	3.84	0.20	1.15	4.15	..
Octane number	57
Flash, C.O.C., ° F.	250	355	475	116	225	..
Fire, C.O.C., ° F.	285	270	..
Flash, Pensky-Martens, ° F.	220	..	103	155	205	..
Vis. at 122° F., sec.	3,000
Vis., Furol, at 77° F., sec.	62
Vis., Furol, at 122° F., sec.	174	..
B.S. & W., °	0.1	0.1	0.3	..
Four-point, ° F.	35	55-60
Cold test, ° F.	below 0	below 0	10	..
100 c.c. A.S.T.M. distillation:											
Initial b.p., ° F.	414	..	90	118	108	..	122	102	346	440	..
5% ..	478	210	143	378	506	..
10% ..	515	..	200	253	226	..	272	163	388	534	..
20% ..	579	..	210	270	244	..	385	190	401	602	..
30% ..	618	..	219	282	255	..	521	646	..
40% ..	644
50% ..	676	..	234	307	280	..	670	251	431	692	..
60% ..	696
70% ..	716	..	254	330	306	..	689	715	..
80% ..	736
90% ..	754	..	293	372	329	494
End point, ° F.	760	..	337	398	374	535
% over	94.5	..	99.0	99.0	88.0	98.5	99.0	87.5	..
% bottoms	1.0	1.0	20.0	1.0	1.0
% coke by weight	6.1	11.1	..	12.4
% loss	0.5
% at 400° F.	21.5
% at 437° F.	2.0	24.0
% at 572° F.	18.5	34.0	..	15.5

Engler Distillation (light oil)

Temperature, ° F.	%	Colour	d_{15}	Engler viscosity at 95° F.	Flash-point, ° F.	Burning-point, ° F.
Crude oil	0.997	0.68	134.6	192.2
Below 302	2.8	orange	0.919
302-572	54.0	light brown	0.956	0.27	140.0	177.8
572-644	30.0	dark brown	0.990	1.15	224.6	365.0
Residue and losses, %	13.2
Melting-point of pitch (Kraemer-Sarnow), ° F.	150.8
Asphalt, %	2.88
Sulphur, %	1.23
Paraffin (Butanone Method), %	1.20

Engler Distillation (heavy oil)

Temperature, ° F.	%	Colour	d_{15}	Engler viscosity at 95° F.	Flash-point, ° F.	Burning-point, ° F.
Crude oil	1.049	0.7	152.6	204.8
Below 302	2.5	yellow	0.916
302-572	58.0	light brown	0.980	0.33	143.6	190.4
572-653	25.5	dark brown	1.056	1.7	191.3	363.2
Residue and losses, %	14.0
Melting-point of pitch (Kraemer-Sarnow), ° F.	156.2
Asphalt, %	2.79
Sulphur, %	1.28
Paraffin, %	1.40

Note. All fractions had a slight green fluorescence in both cases.

Italy

Two fields in Italy, the Valezza and Salsomaggiore, produce crudes of high gasoline-kerosine content, the former yielding 70% gasoline-kerosine, and the latter yielding 60%. Sicilian and Fiume crudes are very heavy, having API. gravities of 13.9 and 19.9 respectively.

There are nine refineries in Italy having a daily capacity of 34,000 bbl. and cracking capacities of 10,900 bbl. The annual production of crude is 500,000 bbl. against an annual consumption of 18,000,000 bbl. (*World Petroleum*, p. 353, Oct. 1934).

Crude Oils from Syria, Albania, Greece, and Turkey

The following analyses are given for the four countries, Syria, Albania, Greece, and Turkey.

TABLE V

Syrian (Bituminous Limestone) Crude Oils

On the addition of water the sample separated into two layers of light and heavy oil.

TABLE VI

Albanian Crude Oils

	Samples		
	No. 1	No. 2	No. 3
d_{15}^4	0.918	0.936	0.970
Flash-point, ° F.	N. temp.	N. temp.	89.6
Burning-point, ° F.	64.4	78.8	111.2
Heat content, cal./g.	10,286	10,246	9,987
Optical rotation	+1.5636	+1.2643	+0.6146

Engler Distillation

	136.4	116.6	138.2
Initial b.p., ° F.			
% distilled over at:			
212° F.	5.9	6.8	2.1
257° F.	9.9	10.2	4.1
302° F.	18.8	15.0	7.1
347° F.	19.8	19.1	10.8
392° F.	22.0	25.7	14.2
437° F.	27.3	27.2	16.0
482° F.	30.7	29.9	19.4
527° F.	33.0	33.5	22.4
572° F.	38.2	36.6	26.7
Asphalt, %	20.69	10.55	11.22
Hard asphalt	0.66	1.74	3.68
Soft asphalt	20.03	8.81	7.54
Paraffin, %	0.26	0.31	0.32
Sulphur, %	2.21	3.57	4.13

TABLE VII

Greece (Isle of Xanthé) Crude Oils

Fractions removed	none
-------------------	------

Hempel Distillation

Yields, vol. % of crude	100.0
-------------------------	-------

Properties of Fractions

Gravity, ° API	9.3	
Sp. gr. at 60° F.	1.0049	
Sulphur, %	5.48	
Flash-point (Cleveland Open Cup), ° F.	265	on a dehydrated sample
Fire-point (Cleveland Open Cup), ° F.	295	
Flash-point (Pensky-Martens), ° F.	185	
Viscosity (Universal), sec. at 100° F.	..	
Viscosity (Universal), sec. at 122° F.	..	
Viscosity (Furol), sec. at 77° F.	..	
Viscosity (Furol), sec. at 122° F.	189	
B.S. & W., %	4.4	
Cold test, ° F.	+25	

Engler Distillation

	414
Initial b.p., ° F.	
% distilled over, ° F.:	
5	509
10	563
20	637
30	673
50	717
70	734
90	736
End point	

Engler Distillation

Total % over	86.5
% bottoms	..
% coke by weight	13.7
% loss	..
% water	4.3 (A.S.T.M.)
% at 400° F.	..
% at 410° F.	..
% at 437° F.	1.0
% at 572° F.	11.0

Remarks: No Hempel Break-up of this crude was given.

TABLE VIII

Turkey (Pulk River Valley) Crude Oils

Sp. gr. at 60° F.	0.8412
Colour	bright yellow with blue shimmer

Engler Distillation

Temperature, ° F.	%	Sp. gr.	Flash-point, ° F.
142-302	3.5	0.700	149
302-572	58.8	0.8240	..
Residuum	37.5	0.8810	..

Oil from First Boring

Sp. gr. at 59° F.	0.820
Flash-point, ° F. (Engler)	113
Paraffins, %	1 to 2

Spanish (Morocco) Crude Oils

The Moroccan field is similar to the Roumanian field. The specific gravity at 15° C. is 0.859. The oil is green-brown in colour. It yields 21% gasoline and is produced at a depth of 427 ft. The one refinery in Spain has a daily capacity of 1,500 bbl. and no cracking installation. The analysis of the crude is shown in Table IX.

TABLE IX

Spanish (Morocco) Crude Oils

Water, %	4.78	
Sp. gr. at 59° F.	0.859	
Flash-point (Open Flame), ° F.	43.6	
Cold-point, ° F.	158-159.8	
Calorific value, cal. per g.	10,712 (19,282 B.Th.U. per lb.)	
Ash, %	0.0026	
Viscosity (Engler), °	2.00 (68 sec. Saybolt)	
Acid content, calculated to oleic acid, 0.211% distillation.		
154-302° F.	21.00% gasoline	Sp. gr. 0.761
302-372° F.	47.60% kerosine	0.860
Over 372° F.	27.30% oil	0.871
Coke	2.30%	..
Gas and loss	1.80%	..

China Crude Oils

Oil has been known in China since ancient times when it was used as a medicine for curing skin diseases. Commercial development of the oil deposits was attempted in 1901 at Yenchang which has been the only field developed. Other deposits are known since seepages are abundant. Analyses of different crudes show gasoline contents from 0.54 to 70.5% of the crudes. There are no refineries in China.

NATURE OF CRUDE PETROLEUM

TABLE X

Chemical Analysis of China Crude Oil

Location	Colour	Sp. gr.	Gasoline		Kerosine		Fuel oil		Fraction above 572° F.	
			%	Sp. gr.	%	Sp. gr.	%	Sp. gr.	%	Sp. gr.
Szefu Well, Tseliuching, Szechuan	dark green (R)	0-8394	17-68	0-7575	26-00	0-8041	9-00	0-8317	49-00	0-8861
Tungshun Well, Tseliuching, Szechuan	green (R)	0-8660	6-41	0-7996	49-82	0-8180	17-00	0-8006	25-23	0-8530
Tungchang Well, Tseliuching, Szechuan	dark green (R)	0-8585	3-75	0-7830	22-25	0-8144	10-50	0-8351	64-20	0-9054
Tis Fu Well, Tseliuching, Szechuan	dark green (R)	0-8748	5-00	0-7920	29-33	0-8148	64-95	0-8983
Hunglung, Kungching, Szechuan	reddish (T)	0-8310	0-54	..	33-23	0-8084	68-40	0-8360
Hunglung, Kungching, Szechuan	reddish (T)	0-8372	0-54	..	35-10	0-8130	66-50	0-8340
Luchuan Tsechung, Szechuan	brownish (R)	0-8393	16-02	0-7558	29-68	0-8238	55-00	0-8689
Luchuan Tsechung, Szechuan	light brown (T)	0-7750	70-50	0-7553	14-50	0-7972	13-50	0-8564
Hoerkan Loshan, Szechuan	dark brown (R)	0-8340	20-00	0-7543	40-66	0-8051	40-00	0-8780
Yenpo, Pahsien, Szechuan	black (R)	0-9134	13-68	0-8420	85-60	0-9135
Tsaichinpao, Yumen, Kansu	black (R)	0-8961	16-55	0-7976	38-40	0-8440	44-80	0-9378
Yenchang, Shensi	black (R)	0-8840	10-70	0-7892	22-65	0-8360	66-60	0-9056
Yenchang, Shensi, Well No. 101	dark green	0-841	11-6	0-681	16-6	0-787
Yungping, Shensi, Well No. 201	dark green	0-851	12-2	0-701	16-7	0-793

(R) Reflected light.

(T) Transmitted light.

SECTION 19

CHEMISTRY OF PETROLEUM

The Chemistry of Hydrocarbons	J. F. THORPE and E. H. FARMER
The Chemical Character of Petroleum and Petroleum Products	B. T. BROOKS
The Chemical Composition of Cracked Gasolines	J. C. MORRELL and G. EGLOFF
OXIDATION AND OXY-COMPOUNDS	
Naphthenic Acids, Oxy-Compounds, &c.	J. VON BRAUN
Gum in Gasoline	W. A. GRUSE
Industrial Oxidation of Petroleum Hydrocarbons	A. W. BURWELL
SULPHUR COMPOUNDS	
The Sulphur Compounds in Petroleum	E. EMMET REID
The Sulphur Compounds of Bituminous Oils	F. CHALLENGER
NITROGEN COMPOUNDS	
The Nitrogen Bases of Petroleum Distillates	J. R. BAILEY
INORGANIC CONSTITUENTS OF PETROLEUM	
Inorganic Constituents of Petroleum	W. H. THOMAS
COLLOIDICS	
Colloid and Capillary Chemistry of Petroleum	H. FREUNDLICH

THE CHEMISTRY OF HYDROCARBONS

By Professor J. F. THORPE, C.B.E., D.Sc., F.R.S., and E. H. FARMER D.Sc.

Imperial College of Science and Technology

I. SATURATED HYDROCARBONS

Paraffins, C_nH_{2n+2}

Occurrence. The paraffins occur extensively in natural gas, petroleum, mineral oils, and mineral waxes from many different sources. The natural gas which issues from the ground in various parts of the earth's surface contains large quantities of methane (50–96%) and ethane (0–20%) and small quantities of propane and higher hydrocarbons. The gasoline and kerosine fractions of most American petroleum consist chiefly of paraffins, but the higher lubricating fractions, after cooling to bring about the deposition of paraffin wax, consist almost entirely of other types of hydrocarbons. The volatile fractions of European and Asiatic petroleum consist in part of paraffins, whilst the tars from the distillation of bituminous shales and lignite, and also low-temperature coal-tars, contain varying proportions of paraffins. The paraffin waxes (m.p. 48–70°) and vaselines (m.p. 30–40°) from American petroleum consist mainly of paraffins containing from 23 to 28 carbon atoms in the molecule; in addition, ozokerite (ceresine), a mineral wax from Galicia and Roumania, and mineral waxes from Tschleken (Caspian Sea) and Baku appear also to consist essentially of higher paraffins.

Isomerism. The paraffins form a homologous series, but isomerism can arise by branching of the carbon chain. Thus hexane, the sixth member of the series, can exist not only in the *normal* or straight-chained form,



but in four additional branched-chain or *iso*-forms, which contain respectively the carbon skeletons

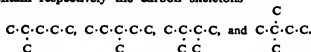

In the higher members of the series the number of possible isomerides becomes very large.

Isolation. The separation of individual hydrocarbons from the volatile fractions of American petroleum by fractional distillation is, except for the earlier members of the paraffin series, a matter of extreme difficulty and usually impossible of accomplishment. This is a consequence of the fact that the hydrocarbons from butane upwards can exist in isomeric forms. Frequently different isomerides, and sometimes different hydrocarbons, have almost identical boiling-points or a group of isomerides may boil within a range of a few degrees; in other cases isomeric substances may differ considerably in boiling-point, and indeed a series of isomerides may have boiling-points extending over a range of 20° or more. In most cases, therefore, where pure hydrocarbon individuals are required they are synthesized by chemical methods.

Methods of Preparation.

The paraffins may be obtained by the following methods: (1) **Hydrogenation of Unsaturated Hydrocarbons.** Olefines, polyolefines, acetylenes, and other unsaturated hydrocarbons of the open-chain series are reduced to the

corresponding paraffins when shaken with excess of hydrogen in the presence of a suitable catalyst.

Usually reduction may be effected in the presence of finely divided platinum or palladium at the ordinary temperature and pressure; with other catalysts such as nickel, higher temperatures and pressures may be required.

(2) **Reduction of Alcohols and Ketones.** Alcohols and ketones may be reduced directly to paraffins by heating with hydriodic acid and red phosphorus, but better results are usually obtained by indirect methods.

Alcohols may be converted into unsaturated hydrocarbons by the action of suitable dehydrating agents (sulphuric acid, phosphoric oxide, anhydrous oxalic acid, small amounts of iodine, hydrobromic acid, &c.), and thence into the corresponding paraffins by catalytic hydrogenation. Alternatively, they may be converted first into bromides or iodides, and thence into the corresponding paraffins by reduction with 'nascent' hydrogen. The required alcohols may be synthesized in wide variety from aldehydes, ketones, acid chlorides, oxides, &c., by the Grignard Reaction:

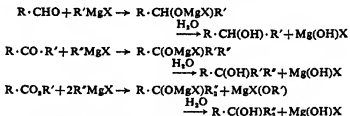

Ketones may be converted first into ketone-chlorides by the action of phosphorus pentachloride and thence into paraffins by reduction with hydriodic acid and red phosphorus.

(3) **Reductive Fission (Hydrogenolysis) of Alcohols.** When heated with nickel at 250° under 100–200 atm. pressure saturated alcohols undergo reductive fission (usually at the terminal carbon atoms of the molecules) to give paraffins:

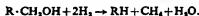

Thus *n*-dodecyl, *n*-tetradecyl, and *n*-octadecyl alcohols yield *n*-undecane, *n*-tridecane, and *n*-heptadecane respectively.

(4) **By the Wurtz Reaction.** Alkyl halides (especially alkyl halides of high molecular weight) are converted into paraffins by the action of sodium, copper powder, or finely divided silver:

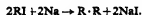

If mixtures of alkyl halides are employed, mixtures of hydrocarbons are obtained:

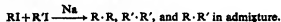

A better result is frequently obtained (especially in the case of the higher alkyl halides) by using magnesium in place of the above-mentioned metals. Magnesium alkyl halides are first formed, and these can react with further quantities of alkyl halide to give hydrocarbon. By this method hydrocarbons containing an odd number of carbon atoms can be conveniently synthesized.

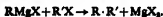

In an analogous manner paraffins may be obtained by the interaction of zinc alkyls and alkyl halides:

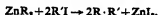

(5) **Decomposition of Organometallic Compounds.** Zinc alkyls, mercury alkyls, and magnesium alkyl halides yield paraffins on decomposition with water:

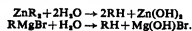

(6) **By Distillation of the Salts of Fatty Acids with Alkali.** When the salts of the lower fatty acids are mixed with soda-lime or caustic alkali and subjected to dry distillation, paraffins are formed:



Under these conditions the higher fatty acids usually give ketones instead of hydrocarbons, but if sodium methoxide is used in place of soda-lime or caustic alkali, good yields of hydrocarbons are obtained.

Physical Properties of the Paraffin Hydrocarbons.

The lowest members of the series up to and including butane and tetramethylmethane are gases at the ordinary temperature; the middle members are colourless, volatile liquids with a characteristic odour; the higher members, from hexadecane, $C_{16}H_{34}$, onwards, are crystalline solids. The earlier members, up to nonadecane, are distillable without serious decomposition at the atmospheric pressure; many of the higher members are distillable at reduced pressure. The increment in boiling-point to be observed in ascending the series is about 30° for the earlier members, but this value subsequently diminishes.

The melting-points, boiling-points, and specific gravities of the lower members of the series, including the isomeric forms of the hydrocarbons from butane to heptane and the known isomeric forms of octane and nonane, are given in the table below. Generally speaking, branching of the chain and the accumulation of methyl groups in the molecule lowers the boiling-point.

The Lower Paraffins

Formula	Hydrocarbon	Structure	M.p.	B.p. (760 mm.)	d
CH_4	Methane	CH_4	-182.5°	-164°	..
C_2H_6	Ethane	$CH_3 \cdot CH_3$	-183.6°	-84.1°	..
C_3H_8	Propane	$CH_3 \cdot CH_2 \cdot CH_3$..	-45°	0.5369°
C_4H_{10}	Butanes:				
	n-Butane	$Me \cdot [CH_2]_2 \cdot Me$	-139.0°	0.6°	0.60°
	isoButane	$CHMe_2$	-145°	-10.2°	..
C_5H_{12}	Pentanes:				
	n-Pentane	$Me \cdot [CH_2]_3 \cdot Me$	-129.73°	36.06°	0.6263 ⁹⁰ °
	isoPentane	$CHMe_2 \cdot CH_2 \cdot Me$	-160.5°	27.95°	..
	Tetramethylmethane	CMe_4	-20°	9.5°	..
C_6H_{14}	Hexanes:				
	n-Hexane	$Me \cdot [CH_2]_4 \cdot Me$	-95.34°	68.70°	0.6594 ⁹⁰ °
	2-Methylpentane	$CHMe_2 \cdot [CH_2]_2 \cdot Me$..	62°	0.6583 ⁹¹ °
	3-Methylpentane	$CHMeEt_2$..	64°	..
	2:2-Dimethylbutane	$CMe_2 \cdot CH_2 \cdot Me$..	49.6°	..
	2:3-Dimethylbutane	$CHMe_2 \cdot CHMe_2$..	49.5-50.5°	0.6512 ⁹² °
C_7H_{16}	Heptanes:				
	n-Heptane	$Me \cdot [CH_2]_5 \cdot Me$	-90.62°	98.38°	0.6838 ⁹⁰ °
	2-Methylhexane	$CHMe_2 \cdot Bu^a$	-119.1°	90.0°	0.7067 ⁹² °
	3-Methylhexane	$CHMeEtPr^a$..	91.8°	0.6865 ⁹² °
	2:2-Dimethylpentane	$CMe_2 \cdot Pr^a$	-125.0°	78.9°	0.6910 ⁹² °
	2:3-Dimethylpentane	$CHMe_2 \cdot CHMeEt$..	(80-1°)	(0.6778 ⁹² °)
	2:4-Dimethylpentane	$CHMe_2 \cdot CHMeEt$..	89.7°	..
	3:3-Dimethylpentane	$CHMe_2 \cdot CH_2 \cdot CHMe_2$	-120.6°	80.8°	0.7002 ⁹² °
	3:4-Dimethylpentane	$CHMe_2 \cdot Et_2$	-134.9°	86-86.5°	0.6952 ⁹² °
	3-Ethylpentane	$CHEt_2$	-118.8°	93.3°	..
	2:2:3-Trimethylbutane	$CHMe_2 \cdot CMe_2$	-25.4°	80.9°	0.6945 ⁹² °
C_8H_{18}	Octanes:				
	n-Octane	$Me \cdot [CH_2]_6 \cdot Me$	-56.82°	125.59°	0.7028 ⁹⁰ °
	2-Methylheptane	$CHMe_2 \cdot [CH_2]_4 \cdot Me$..	116.0° (761 mm.)	0.7035 ⁹¹ °
	3-Methylheptane	$CHMeEt \cdot [CH_2]_3 \cdot Me$..	117.6°	0.7167 ⁹¹ °
	4-Methylheptane	$CHMePr_2^a$..	118.0°	0.7217 ⁹¹ °
	2:2-Dimethylhexane	$CMe_2 \cdot Bu^a$..	106.7°	0.6967 ⁹² °
	2:3-Dimethylhexane	$CHMe_2 \cdot CHMePr^a$..	113.9° (758 mm.)	0.7246 ⁹¹ °
	2:4-Dimethylhexane	$CHMe_2 \cdot CH_2 \cdot CHMeEt$..	110.0° (763 mm.)	0.7083 ⁹¹ °
	2:5-Dimethylhexane	$CHMe_2 \cdot [CH_2]_3 \cdot CHMe_2$..	108.25°	0.6991 ⁹¹ °
	3:3-Dimethylhexane	$CMe_2 \cdot EtPr^a$..	(109.2°)	(0.6952 ⁹² °)
	3:4-Dimethylhexane	$CHMeEt \cdot CHMeEt$..	111-12°	0.7116 ⁹¹ °
	3-Ethylhexane	$CHEt_2 \cdot Pr^a$..	116.5° (759 mm.)	0.7270 ⁹¹ °
	2:2:3-Trimethylpentane	$CMe_2 \cdot CHMeEt$..	118.9° (766 mm.)	0.7175 ⁹¹ °
	2:2:4-Trimethylpentane	$CMe_2 \cdot CH_2 \cdot CHMe_2$	-107.8°	110.2°	0.7173 ⁹¹ °
	2:3:3-Trimethylpentane	$CHMe_2 \cdot CH_2 \cdot CHMe_2$..	99.3°	0.6918 ⁹² °
	2:3:4-Trimethylpentane	$CHMe_2 \cdot CMe_2 \cdot Et$..	113.6°	0.7258 ⁹² °
	2:3:4-Trimethylpentane	$CHMe_2 \cdot CHMe \cdot CHMe_2$..	112.8°	0.7197 ⁹² °
	2-Methyl-3-ethylpentane	$CHMe_2 \cdot CHEt_2$..	114°	0.7084 ⁹¹ °
	2:2:3:3-Tetramethylbutane	CMe_4	104°	106.7°	..

The Lower Paraffins (cont.)

Formula	Hydrocarbon	Structure	M.p.	B.p. (760mm.)	d	
C ₉ H ₂₀	Nonanes:					
		n-Nonane	Me-[CH ₂] ₇ -Me	-53-70*	150-72*	0-7178 ⁹⁰
		3-Methyloctane	CHMeEt-[CH ₂] ₅ -Me	..	143-4*	0-719 ⁹⁰
		4-Methyloctane	CHMePr-Bu*	..	141-8* (771 mm.)	0-7320 ⁹⁰
		2:4-Dimethylheptane	CHMe ₂ -CH ₂ -CHMePr*	..	132-9* (752 mm.)	0-7206 ⁹⁰
		2:5-Dimethylheptane	CHMe ₂ -[CH ₂] ₂ -CHMeEt	..	135-6-135-9*	0-7190 ⁹⁰
		2:6-Dimethylheptane	CHMe ₂ -[CH ₂] ₃ -CHMe ₂	..	132-0*	0-707 ⁹⁰
		3:3-Dimethylheptane	CMe ₂ EtBu*	..	137-8*	0-7304 ⁹⁰
		4-Ethylheptane	CHEtPr*	..	139-0*	0-737 ⁹⁰
		2:2:5-Trimethylhexane	CMe ₂ CH ₂ -CHMe ₂	..	{ 126-0*	{ 0-707 ⁹⁰
		3:3-Diethylpentane	CEt ₂	..	{ (121-3*)	{ (0-7091 ⁹⁰)
				139-2*	0-7522 ⁹⁰	

* Extrapolated values.

In the following table the melting-points, boiling-points, and specific gravities of a number of the middle and higher hydrocarbons of the normal series are recorded.

The Normal Paraffins

Formula	Hydrocarbon	M.p.	B.p.	Sp. gr.
C ₁₀ H ₂₂	Decane	-29-68°	174-02° (760 mm.)	0-7301 ⁹⁰
C ₁₁ H ₂₄	Undecane	-25-61°	195-84° "	0-7411 ⁹⁰
C ₁₂ H ₂₆	Dodecane	-9-61°	216-23° "	0-7511 ⁹⁰
C ₁₃ H ₂₈	Tridecane	-6-2°	234° "	0-7571 ⁹⁰
C ₁₄ H ₃₀	Tetradecane	+5-5°	252-5° "	0-7645 ⁹⁰
C ₁₅ H ₃₂	Pentadecane	10°	270° "	0-7689 ⁹⁰
C ₁₆ H ₃₄	Hexadecane	19°	287-5° "	0-7707 ⁹⁰
C ₁₇ H ₃₆	Heptadecane	22-5°	303° "	0-7766 ⁹⁰
C ₁₈ H ₃₈	Octadecane	28°	317° "	0-7768 ⁹⁰
C ₁₉ H ₄₀	Nonadecane	32°	330° "	0-7774 ⁹⁰
C ₂₀ H ₄₂	Eicosane	36-4°	205° (15 mm.)	0-7779 ⁹⁰
C ₂₁ H ₄₄	Heneicosane	40-4°	215° "	0-7783 ⁹⁰
C ₂₂ H ₄₆	Docosane	47°	224° "	0-7782 ⁹⁰
C ₂₃ H ₄₈	Tricosane	47-7°	234° "	0-7785 ⁹⁰
C ₂₄ H ₅₀	Tetracosane	54°	243° "	0-7786 ⁹⁰
C ₂₅ H ₅₂	Pentacosane	53-3°	282° (40 mm.)	0-7911 ⁹⁰
C ₂₆ H ₅₄	Hexacosane	56-9°	199° (0-4 mm.)	..
C ₂₇ H ₅₆	Heptacosane	59-5°	270° (1-5 mm.)	0-7796 ⁹⁰
C ₂₈ H ₅₈	Octacosane	64-5°	{ 316-18° (40 mm.)	..
			{ 224° (1-1 mm.)	..
C ₂₉ H ₆₀	Nonacosane	63-6-64-1°
C ₃₀ H ₆₂	triacontane	69-70°	235° (1 mm.)	..
C ₃₁ H ₆₄	hentriacontane	68-1°	302° (1-5 mm.)	0-7808 ⁹⁰
C ₃₂ H ₆₆	dotriacontane	74-5°	245° (1-5 mm.)	0-7754 ⁹⁰
C ₃₃ H ₆₈	tritriacontane	71-1°
C ₃₄ H ₇₀	tetracontane	76-76-5°	255° (1 mm.)	..
C ₃₅ H ₇₂	pentatriacontane	73°	331° (1-5 mm.)	..
C ₃₆ H ₇₄	hexatriacontane	78-5°	265° (1 mm.)	..
C ₃₇ H ₇₆	tetracontane	80-5-81°
C ₃₈ H ₇₈	pentacantane	91-9-92-3°
C ₃₉ H ₈₀	hexacantane	101-2°
C ₄₀ H ₈₂	heptacantane	105-10-5°

Chemical Properties of the Paraffin Hydrocarbons.

The paraffins are characterized by a comparatively high degree of stability towards chemical reagents. Nevertheless, the members of this group, especially tertiary hydrocarbons, CHRR'R', and the higher members contained in paraffin wax, are not entirely immune from attack. The chief modes of reaction are the following:

Oxidation. (a) *At atmospheric pressure.* The simpler hydrocarbons when submitted to the action of air or oxygen at temperatures in the neighbourhood of 300° undergo oxidation with the formation of peroxidic derivatives. Tertiary hydrocarbons such as 2-ethylbutane,

CHMeEt₂, are prone to attack by dilute permanganate, but normal hydrocarbons, on the other hand, are very resistant towards this reagent; usually the only recognizable products obtainable by means of permanganate are simple substances such as carbon dioxide and formic acid.

Normal hydrocarbons, and the tetra-alkylmethanes CMe₂Et₂ and CEt₄, have been successfully oxidized with air in the presence of various catalysts such as copper, vanadium pentoxide, and cerium dioxide, but only carbon monoxide, carbon dioxide, water, traces of aldehydes of low molecular weight, and unsaturated hydrocarbons have been obtained thereby. The oxidation of 3-ethylpentane, CH₂Et₂, and of other tertiary hydrocarbons, can be effected by

boiling with benzoyl peroxide: in this way benzoyl esters (which yield tertiary alcohols on saponification) and large proportions of secondary products are formed. Tertiary hydrocarbons can also be oxidized by means of concentrated nitric acid, but treatment of hydrocarbons with dilute nitric acid gives nitro-derivatives as well as oxidation products.

The higher hydrocarbons (including the naphthenes) contained in paraffin wax, and hydrocarbon oils are oxidized by air at temperatures of about 160°, with production of fatty acids, hydroxy-acids, peracids, and non-acidic products. In the absence of catalysts (save for a little previously oxidized material) high yields of fatty acids are reported to be obtainable. Increased pressure accelerates the oxidation, but the use of oxygen in place of air is liable to lead to explosions owing to the formation of peroxides.

The non-acidic products from long-chain paraffins have been found to contain long-chain secondary alcohols and ketones, which, according to Burwell [13, 1934], bear the oxygen atom primarily at the second carbon atom of the chain, but to a lesser extent on the third atom, and so on towards the centre of the molecule. Oxidative fission of the molecule may subsequently occur at the oxygenated atoms, thus yielding carboxylic acids, or fission may occur together with further oxidation at the 2-, 3-, &c., positions of the chain, the products then being hydroxy- or ketonic-acids.

Passage of the vapour of paraffin wax (m.p. 49°) admixed with air over reduced nickel has been observed to give mixtures of aldehydes, probably of the C₈ to C₁₁ series. The electrochemical oxidation of paraffin wax (m.p. 38–53°) has yielded mainly fatty acids together with carbon dioxide and unsaponifiable matter, but little in the way of hydroxy-acids and volatile products of low molecular weight.

(b) *At high pressure.* Submission of methane under atmospheric pressure to the action of oxygen or air at temperatures sufficiently high to promote reaction at a reasonable rate (400–700°) yields only traces of formaldehyde, methyl alcohol, and formic acid. The yield of methyl alcohol improves somewhat with increased pressure (e.g. 135 atm.), but the rate of increase of total carbon-conversion into useful products falls off as the pressure rises. Methyl alcohol is the main oxidation product of ethane at suitably elevated temperatures (e.g. 350°) and high pressures (130–200 atm.), but numerous products, principally Me·CHO, COMe₂, Me·CO₂H, MeOH, EtOH, PrOH, BuOH, are obtained by oxidation of propane under analogous conditions [100, 1934]. Butane and pentane also give a considerable number of oxidation products of low molecular weight when heated with air at increased pressure, but heptane undergoes reaction (in the liquid phase) at a much lower temperature than do its lower homologues, and the nature of the products indicates that less severe degradation occurs. In general, when oxidation is performed at relatively high temperatures, side reactions such as dehydrogenation, cracking, and polymerization occur which complicate and conceal the nature of the initial oxidation reactions.

Nitration. Concentrated or fuming nitric acid, or nitric acid-sulphuric acid mixtures, yield for the most part oxidation products with paraffin hydrocarbons. The best results are obtained by heating the latter with dilute nitric acid (e.g. acid of sp. gr. 1.025–1.075). Tertiary hydrocarbons are thus readily nitrated at the tertiary carbon atoms, secondary hydrocarbons with less readiness, and normal

hydrocarbons and tetra-alkylmethanes only with difficulty. In compounds of the last type, however, the presence of the grouping CR₃ appears to promote substitution at an adjacent secondary carbon atom. Aryl paraffins (as also arylcyclohexanes) often undergo substitution in the saturated chain or ring in preference to the aromatic nucleus.

Sulphonation. On warming with fuming sulphuric acid many open-chain paraffins and cyclohexanes undergo extensive sulphonation; oxidation, however, is often the more important reaction. Hydrocarbons containing a tertiary carbon atom are much more prone to sulphonation than are normal paraffins.

Halogenation. Although the paraffins, especially the normal paraffins, display some degree of resistance to halogenation, the direct substitution of a part or the whole of the hydrogen by chlorine can usually be effected under suitable conditions.

The chlorination of methane is promoted by actinic light, by heat, and by catalysts. Chlorination in the dark at 300–400° C. yields methyl chloride together with carbon tetrachloride, or at 400° C. in presence of pumice impregnated with cuprous chloride, mainly carbon tetrachloride (78% yield); chlorination at elevated temperatures in presence of various activated charcoals and carbons also gives mixtures of methyl chloride and carbon tetrachloride, but in the presence of coke impregnated with iron or nickel chloroform is extensively formed.

Ethane is more readily chlorinated than methane, and under suitable conditions may yield ethyl chloride, ethylidene chloride, and ethylene dichloride. Propane and the succeeding homologues of the normal series may also be directly chlorinated at ordinary or at somewhat more elevated temperatures, *n*-pentane giving mixtures of the 1- and 2-monochloro-derivatives, and *n*-hexane mixtures of the 1-, 2-, and 3-monochloro-derivatives. *Isobutane* is readily chlorinated at the ordinary temperature; *isopentane* (2-methylbutane) yields with moist chlorine mixtures consisting mainly of the two primary monochlorides and with dry chlorine mixtures of all the four possible monochlorides. The higher boiling petroleum fractions may readily be chlorinated in diffused daylight, and the paraffin waxes likewise undergo substitution. Bromine reacts with the paraffins very much less readily than does chlorine.

Reaction with Sulphur. The higher paraffins, paraffin oils, and paraffin waxes yield hydrogen sulphide copiously on heating with sulphur at temperatures between 200 and 400° C., but only traces of sulphur derivatives appear to be formed. The reaction, however, does not appear to afford a convenient means for the regulated dehydrogenation of hydrocarbons: aromatic derivatives have been found in the products from cyclohexanes, but the dehydrogenated products from open-chain hydrocarbons can themselves react very readily with sulphur to yield carbonized materials.

Reaction with Aluminium Chloride. *n*-Hexane and *n*-heptane undergo a variety of transformations when warmed with freshly sublimed or moist aluminium chloride. Amongst other compounds *isoparaffins*, *cycloparaffins*, and *olefines* are formed.

Friedel-Crafts' Reaction. In the presence of anhydrous aluminium chloride the paraffins react with acetyl chloride to yield ketones, and with carbon monoxide (at increased pressures) to yield ketones or mixtures of ketones and acids. The following reactions are typical:

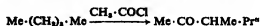

a 'primary', 'secondary', and 'tertiary' hydrogen atom, the following 4 cycles:

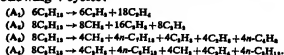

According to this result 1 molecule of *n*-octane yields by the different cycles either 4 or 2.5 molecules of product, the mean by all the different methods being 3.2.

On the same basis it is possible to calculate the products of the decomposition of any hydrocarbon without ambiguity, and this has been done for a number of compounds with results that agree well with experimental observations.

II. ETHYLENIC HYDROCARBONS

Mono-olefines or Ethylenes, C_nH_{2n}

The hydrocarbons of this group form a homologous series, the members of which contain 2 atoms of hydrogen less than the corresponding paraffins. Each member of the group contains a centre of unsaturation in the molecule which is structurally represented by a double linkage or double bond between a pair of adjacent carbon atoms. In hydrocarbons containing more than 3 carbon atoms usually more than one position can be occupied by the double bond, so that pairs or groups of isomerides arise, the individuals of which differ from one another solely in the position of the double bond. Another source of isomerism, viz. that due to modification of the carbon skeleton by branching of the chain, applies to olefines equally with the paraffins.

Occurrence. The olefines occur extensively in thermally decomposed or 'cracked' mineral oils, but the isolation of pure individuals from the mixtures of hydrocarbons so obtained is not as a rule possible.

Methods of Preparation.

(1) The dehydration of monohydric alcohols, $C_nH_{2n+1}OH$. This is effected by treatment at a suitable temperature with dehydrating agents such as sulphuric acid, phosphoric anhydride, anhydrous oxalic acid, and boron trioxide, or by slow distillation with small amounts of catalysts such as hydrogen bromide, iodine, and aniline hydrochloride; also by passage of their vapours over contact reagents such as kaolin, alumina, or silica gel heated to a suitable temperature.

Secondary, and particularly tertiary, alcohols undergo dehydration with great readiness. The higher alcohols which are not volatile without decomposition usually undergo dehydration on heating; thus cetyl alcohol, $C_{16}H_{34}O$, yields cetene, $C_{16}H_{32}$, on distillation.

Certain olefines can be conveniently prepared from the corresponding alcohols by heating the esters which they form with xanthic acids; the higher olefines can be analogously prepared from the corresponding alcohols by distilling the esters which they form with the fatty acids.



Methyl xanthate of methyl
tert.-butyl carbonyl

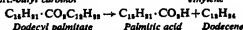

Dodecyl palmate *Palmitic acid* *Dodecene*

The xanthic ester synthesis is particularly valuable in the preparation of *tert.*-alkyl derivatives of ethylene which are otherwise difficult to prepare free from structural isomerides: owing to the relatively low temperature of decomposition of the xanthic esters the method may be relied on to leave the *tert.*-butyl groups untransformed.

(2) The elimination of hydrogen halide from mono-halogen derivatives of paraffins. This is carried out by heating with alcoholic sodium or potassium hydroxide or with quinoline; sodium phenates have also been used with success for the same purpose. In some cases the elimination of hydrogen halide can be effected by passing the vapours of the halogen compounds over heated contact materials such as barium chloride or finely divided metals (Ni, Co, Fe, Cd, Ba, Pb).

Secondary, and especially tertiary, halogen compounds lose hydrogen halide very readily. The decomposition is usually most facile with iodides: tertiary iodides give olefines even when treated with ammonia.

(3) Dehalogenation of dihalogeno-compounds by metals. Compounds in which the halogen atoms are attached to adjacent carbon atoms, e.g. the halogen addition products of olefines, are converted by powdered metals (especially by zinc dust in alcohol) into olefines. In the case of ethylene or ethylene halides sodium may be used.

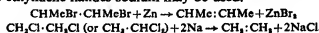

(4) Distillation of quaternary ammonium hydroxides or of the corresponding ammonium salts.

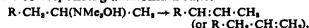

(5) Action of magnesium alkyl halides or zinc alkyls on alkyl halides.

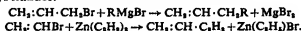

(6) The action of zinc on 2-bromo-ethers.

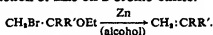

This reaction has been successfully employed in synthesizing 10 of the 13 possible structurally isomeric hexenes, 18 of the 27 possible heptenes, and many other hydrocarbons. The following series of reactions is employed in synthesizing the 2-bromo-ethers:

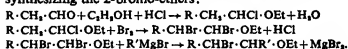

(7) The coupling of alkyl halides and halogeno-olefines by the Wurtz reaction. This reaction has been used in the synthesis of the higher olefines.



(8) Polymerization of lower olefines. The olefines yield dimeric, trimeric, tetrameric, &c., polymerides containing one double bond on treatment with suitable reagents (see p. 956).

(9) The interaction of olefines with tertiary alcohols or alkyl iodides in presence of zinc chloride or sulphuric acid. In this way *isobutene* and *tert.* butyl alcohol yield *di-isobutene*.

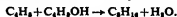

Course followed in Elimination Reactions.

(1) **Alternative Directions of Elimination.** In general, secondary or tertiary alcohols may suffer loss of water in more than one direction. Similar alternative courses of elimination apply also in the case of *sec.*- and *tert.*-alkyl halides and of analogous alkylamino-paraffins.

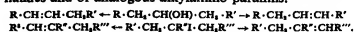

Owing to this dual potentiality (three-fold for *tert.* alcohols or halides) olefines higher in the series than propylene are commonly obtained in non-homogeneous condition. The

in the table, high-boiling and low-boiling forms, presumably representing geometrical isomerides, have been isolated.

In general, Δ^1 -olefines boil lower than Δ^2 -olefines, and branching of the chain in an alkyl group directly attached to one of the unsaturated carbon atoms of an olefine tends to lower the boiling-point. On the other hand, accumulation of methyl groups on the unsaturated carbon atoms of an olefine tends to raise the boiling-point. It would appear from present observations that the more deeply the point of unsaturation is buried within the molecular structure the higher the boiling-point; and the more it is exposed, the lower the boiling-point.

For the most part the densities and refractive indices follow the boiling-point, rising or falling with it as it changes from example to example.

Reactions.

Additive Reactions. Owing to their unsaturation the olefines show a marked capacity to add reagents at the

double bond: they can thus unite directly with two univalent atoms or groups whereby the double bond becomes single. The following are the most important types of reaction:

(1) They combine with hydrogen in the presence of catalysts (notably the metals palladium, platinum, and nickel, but also compounds of molybdenum, chromium, copper, &c.) to yield paraffins with the same number of carbon atoms.

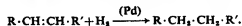

In many cases, especially in the presence of palladium or platinum, reaction takes place readily at the ordinary temperature and pressure; in other cases, owing either to the constitution of the hydrocarbon or the inferior activity of the catalyst, higher temperatures and pressures are required. The presence of traces of certain substances (e.g. sulphur compounds and halogen compounds) which 'poison' the catalyst may inhibit addition.

Olefines (C_nH_{2n})

	Hydrocarbon	Formula	B.p. (°C./760 mm.)	d ₄ ²⁰
C ₂ H ₄	Ethylene	CH ₂ :CH ₂	-105	..
	Propene, propylene	CH ₂ :CHMe	-48.2 (749 mm.)	..
	Δ^1 -Butene, α -butylene	CH ₂ :CHEt	-5	..
C ₄ H ₈	Δ^1 -Butene, β -butylene	CHMe:CHMe	+0.5 (<i>cis</i>)	..
	<i>iso</i> Butene, <i>isobutylene</i>		+2.5 (<i>trans</i>)	..
	Δ^1 -Pentene	CH ₂ :CMe ₂	6.3	..
C ₅ H ₁₀	Δ^1 -Pentene	CH ₂ :CHPr ^a	30.2	0.6420
	Δ^2 -Pentene	CHMe:CHEt	36.40	0.6503
	2-Methyl- Δ^1 -butene	CH ₂ :CMeEt	31-2	0.6668 ^b
C ₆ H ₁₂	3-Methyl- Δ^1 -butene	CH ₂ :CHPr ^{β}	20-10	0.6320 ^b
	2-Methyl- Δ^2 -butene	CHMe:CMe ₂	38.42	0.6671 ^b
	Δ^1 -Hexene	CH ₂ :CHBu ^a	63.4-63.7	0.6732
C ₇ H ₁₄	2-Methyl- Δ^1 -pentene	CH ₂ :CMePr ^a	61.5-62.0	0.6817
	3-Methyl- Δ^1 -pentene	CH ₂ :CH-CMeEt	53.6-54.0	0.6700
	4-Methyl- Δ^1 -pentene	CH ₂ :CH-CH ₂ Pr ^{β}	53.6-53.9	0.6646
C ₈ H ₁₆	Δ^1 -Hexene	CHMe:CHPr ^a	67.9-68.1	0.6813
	2-Methyl- Δ^2 -pentene	CMe ₂ :CHEt	67.2-67.5	0.6904
	3-Methyl- Δ^2 -pentene	CHMe:CMeEt	65.7-66.2 (<i>cis</i>)	0.6940
C ₉ H ₁₈	4-Methyl- Δ^2 -pentene		67.6-68.2 (<i>trans</i>)	0.6956
	Δ^1 -Hexene	CHMe ₂ :CH:CHMe	54.2-55.2 (<i>cis</i>)	0.6702
	2,3-Dimethyl- Δ^1 -butene		57.7-58.5 (<i>trans</i>)	0.6709
C ₁₀ H ₁₈	Δ^1 -Heptene	CHEt:CHEt	66.6-67.0	0.6816
	2,3-Dimethyl- Δ^1 -butene	CH ₂ :CMe-CMe ₂	56.0	0.6803
	3,3-Dimethyl- Δ^1 -butene	CMe ₂ :CH:CH ₂	41.2	0.6510
C ₁₁ H ₂₀	2-Ethyl- Δ^1 -butene	CH ₂ :CEt ₂	66.2-66.7	0.6914
	2,3-Dimethyl- Δ^2 -butene	CMe ₂ :CMe ₂	73.4	0.7077
	Δ^1 -Heptene	CH ₂ :CH-CH ₂ -CH ₂ Pr ^a	94.9	0.6993
C ₁₂ H ₂₂	2-Methyl- Δ^1 -hexene	CH ₂ :CMeBu ^a	91.1-91.5	0.7000
	3-Methyl- Δ^1 -hexene	CH ₂ :CH-CHMePr ^a	83.8-84.0	0.6953
	4-Methyl- Δ^1 -hexene		84.0-84.1	0.6945
C ₁₃ H ₂₄	5-Methyl- Δ^1 -hexene	CH ₂ :CH-CH ₂ -CHMeEt	87.2-87.5	0.6959
	Δ^1 -Heptene	CH ₂ :CH-CH ₂ -CH ₂ Pr ^{β}	84.7	0.6936
	2-Methyl- Δ^2 -hexene	CHMe:CHBu ^a	98.1-98.4	0.7034
C ₁₄ H ₂₆	2-Methyl- Δ^2 -hexene	CMe ₂ :CHPr ^a	94.4-94.6	0.7089
	3-Methyl- Δ^2 -hexene	CHMe:CMePr ^a	93.1-93.3	0.7120
	4-Methyl- Δ^2 -hexene	CHMe:CH-CHMeEt	85.1-85.6 (<i>cis</i>)	0.6981
C ₁₅ H ₂₈	5-Methyl- Δ^2 -hexene		87.1-87.6 (<i>trans</i>)	0.7007
	Δ^1 -Heptene	CHMe:CH-CH ₂ Pr ^a	85.6-86.1 (<i>cis</i>)	0.7020
	2-Methyl- Δ^3 -hexene		91.1-91.6 (<i>trans</i>)	0.6990
C ₁₆ H ₃₀	2-Methyl- Δ^3 -hexene	CHEt:CHPr ^a	95.8-96.1	0.7043
	2,3-Dimethyl- Δ^1 -pentene	CHEt:CHPr ^{β}	86.4-86.9	0.6942
	2,4-Dimethyl- Δ^1 -pentene	CH ₂ :CMe-CHMeEt	84.1-84.3	0.7054
C ₁₇ H ₃₂	3,3-Dimethyl- Δ^1 -pentene	CH ₂ :CMe-CH ₂ Pr ^{β}	80.9-81.3	0.6937
	2-Ethyl- Δ^1 -pentene	CH ₂ :CH-CMe ₂ Et	76.9	0.6961
	3,4-Dimethyl- Δ^1 -pentene	CH ₂ :CEtPr ^a	93.9-94.3	0.7079
C ₁₈ H ₃₄	4,4-Dimethyl- Δ^1 -pentene	CHMe:CMePr ^{β}	86.2-86.4	0.7126
	3-Ethyl- Δ^1 -pentene	CHMe:CH-CMe ₂	76.0-76.1	0.6881
	3-Methyl- Δ^2 -heptene	CHMe:CEt ₂	94.8-94.9	0.7172
C ₁₉ H ₃₆	Δ^1 -Octene	CH ₂ :CEtPr ^a	88.7-89.1	0.7186
	4,4-Dimethyl- Δ^2 -hexene	CH ₂ :CH-[CH ₂] ₂ -Bu ^a	121.5-122.5	0.7158
	5,5-Dimethyl- Δ^2 -hexene	CHMe:CH-CMe ₂ Et	105.4-106.0	0.7202
C ₂₀ H ₃₈	Δ^1 -Nonene	CHEt:CH-CMe ₂	100.1	0.7048
		CH ₂ :CH-[CH ₂] ₃ -Bu ^a	145.0-145.6	0.7315

(2) With halogens (e.g. Cl_2 , Br_2 , I_2 , ICl) they combine to yield dihalides.

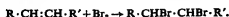

(3) They yield chlorohydrins with aqueous solutions of chlorine or hypochlorous acid, and bromohydrins with aqueous solutions of bromine or of hypobromous acid. They also form addition products of analogous type with alkyl hypochlorites and react additively with chlorine monoxide. In general, mixtures of isomeric addition products are formed (see p. 945).

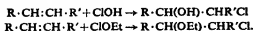

(4) They add the halogen acids, particularly hydrogen bromide and hydrogen iodide, to give alkyl halides. In many cases mixtures of alkyl halides are formed (see p. 945).

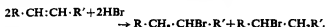

(5) With nitrosyl chloride they form nitroso-chlorides.

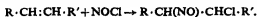

(6) They unite with N_2O_3 and N_2O_4 to form pseudo-nitrosites, $\text{R}\cdot\text{CH}(\text{NO}_2)\cdot\text{CH}(\text{NO})\cdot\text{R}'$, and dinitro-compounds, $\text{R}\cdot\text{CH}(\text{NO}_2)\cdot\text{CH}(\text{NO}_2)\cdot\text{R}'$.

(7) They are oxidized by dilute permanganate to 1:2-glycols, $\text{R}\cdot\text{CH}(\text{OH})\cdot\text{CH}(\text{OH})\cdot\text{R}'$. Peroacetic acid and perbenzoic acid give olefine oxides which in contact with acetic acid become more or less completely transformed into the monoacetate of the diol. Lead tetra-acetate yields glycols or the corresponding diacetates, whilst the complex formed by mixing iodine with silver benzoate effects oxidation to 1:2-glycol dibenzoates.

(8) Oxygen is absorbed by olefines with widely varying degrees of facility to yield monomeric or polymeric peroxides containing the grouping $\cdot\text{O}\cdot\text{O}\cdot$. Thus cyclohexene yields a monomeric peroxide, whereas diphenylethylene yields a highly polymerized peroxide. Many of the peroxides are explosive, but usually only small proportions of peroxide are formed even after prolonged contact of the hydrocarbon with oxygen. The presence of peroxides may be instrumental in promoting the oxidation of olefines by oxygen to ketones or aldehydes.

According to Staudinger [82, 1925] the oxidation of olefines by oxygen proceeds thus:

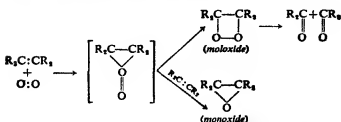

(9) Ozone adds to the double bond of olefines to form monomeric or polymeric ozonides, many of which are highly explosive.

Staudinger [82, 1925] considers that the first step is the formation of a 'molozonide' which undergoes one of the changes: (i) polymerization to give an ozonide of high molecular weight, such as is obtained from cyclopentene, (ii) isomerization to yield an *isozonide*, to which class stable, distillable ozonides such as ethylene ozonide prob-

ably belong, or (iii) thermal fission to give a ketone and ketone peroxide or acid.

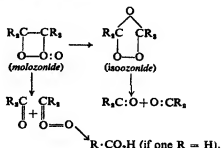

(10) In the presence of suitable catalysts (e.g. Ni on kieselguhr or phosphoric acid on charcoal) the lower olefines unite with hydrogen sulphide at 200–300° to give mercaptans. Certain aryl and acetylenyl olefines, such as styrene and divinylacetylene, unite with thiophenol or its homologues to give sulphides.

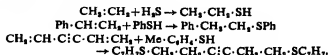

(11) Certain olefines yield polymeric addition products with maleic anhydride and with sulphur dioxide (the latter in presence of traces of peroxide). Thus styrene and indene yield polymolecular maleic anhydride derivatives, and cyclohexene a polymolecular sulphone.

The cyclic hydrocarbon sabinene forms a sulphonic acid derivative when SO_3 is passed into its cooled alcoholic solution.

(12) Many olefines are absorbed by strong sulphuric acid to yield alkyl hydrogen sulphates which decompose into the olefine and sulphuric acid on heating or into the corresponding secondary alcohols on boiling with water.

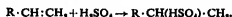

Ethylene combines with sulphur trioxide to yield carbyl sulphate.

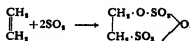

(13) At high temperatures (290–300°) they can combine with the fatty acids to give esters.

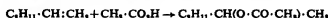

Propane combines with acetic, mono-, di-, and trichloroacetic acids and benzoic acid at 70° in the presence of a little boron trifluoride.

(14) The olefines combine with many different metallic salts to form metal salt-olefine complexes, e.g. C_2H_4 , ZnCl_2 and $\text{K}(\text{PtCl}_6)$, C_2H_4 . With mercuric salts compounds of the type $\text{R}\cdot\text{CH}(\text{OH})\cdot\text{CH}_2\cdot\text{HgX}$ are formed, which yield alcohols on hydrolysis. The ready formation of such mercury compounds affords a means of hydrating olefines.

(15) By the action of heat, light, electric discharge, and of numerous chemical reagents they are converted into polymeric (see pp. 955 and 956).

(16) At high temperatures, especially in presence of certain contact reagents, the olefines undergo isomerization, either by shift of the double bond or by migration of an alkyl group (see p. 942).

(17) Certain polyaryl-olefines (e.g. tetraphenylethylene and *o*-diphenylethylene) add the alkali metals, thereby

yielding monomolecular or polymolecular metallic derivatives.

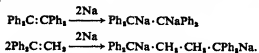

(18) Styrene and other olefines unite with aromatic bases (aniline and toluidine) when heated in the presence of the hydrohalide of the base giving products of two types:

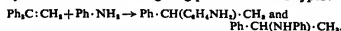

In the formation of the first of these the addendum may be considered to be $\text{H}-\text{C}_6\text{H}_4 \cdot \text{NH}_2$, and in that of the second $\text{H}-\text{NH} \cdot \text{C}_6\text{H}_5$. An analogous reaction is the union of styrene with benzenoid hydrocarbons in the presence of concentrated sulphuric acid to give saturated hydrocarbons.



(19) In the presence of anhydrous aluminium chloride the olefines unite with aromatic hydrocarbons to give alkylbenzenes and with acid chlorides to give unsaturated ketones.

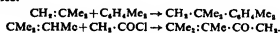

Direction of Addition.

In general, unsymmetrical addenda such as HBr, HI, ICl, ClOH, HOH, and NOCl can add to the ethylenic linkage in two ways as is here shown for HBr:

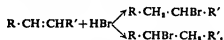

The components of the addendum thus become added in opposite directions and a mixture of isomeric addition products results. Clearly such isomeric products can only arise if the olefine is unsymmetrical in nature; but even for unsymmetrical olefines one of the directions of addition may be favoured at the expense of the other, with the result that the product consists wholly or preponderantly of one substance.

The direction of addition is largely dependent on the structure of the olefine, and in hydrocarbons of the types $\text{CRR}':\text{CH}_2$, $\text{CHR}:\text{CH}_2$, $\text{CRR}':\text{CHR}'$ (R, R', R' = alkyl groups) the negative part of the addendum, i.e. $\cdot\text{Br}$, $\cdot\text{Cl}$, $\cdot\text{OH}$, &c., tends to add most extensively, although not necessarily exclusively, at the most substituted carbon atom; moreover, in the case of a symmetrically di-substituted olefine, $\text{CHR}:\text{CHR}'$, the substituents of which, R and R', are different alkyl groups (this applies more particularly when R and R' are simple alkyl groups, e.g. Me, Et, Pr, and Bu), the negative part of the addendum tends to add most extensively at the carbon atom bearing the larger alkyl group. Addition, therefore, leads most frequently to the production of secondary or tertiary halides, alcohols, esters, &c., the direction of addition necessary to produce primary derivatives from unsymmetrical olefines of the types $\text{CHR}:\text{CH}_2$ and $\text{CRR}':\text{CH}_2$ being the less favoured one.

Orienting Mechanism. In accordance with current electronic theories of chemical behaviour it is customary to assume that all reactions of unsaturated substances are preceded by a degree of electromeric polarization. Thus considering the ethylenic system $\text{>C}=\text{C}<$, and replacing each of the valencies in the customary manner by a pair of

electrons, it is clear that displacement of a pair of the electrons composing the double bond (i.e. displacement of a pair of the electrons which are shared by both of the carbon atoms) towards the nucleus of one or other of the carbon atoms will lead to the production of a structure which may be regarded as an electronic isomeride (electro-meride) of the original compound.

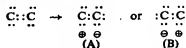

Provided the displaced electron pair becomes wholly appropriated by the nucleus of one or other of the ethylenic carbon atoms, the atom so augmented necessarily acquires an integral negative charge and the depleted carbon atom an integral positive charge. The change is represented by

the symbol $\overset{\ominus}{\text{C}}-\overset{\oplus}{\text{C}}$ which implies that to some extent the electrons are breaking away from one carbon atom and remaining attached to the other. If the change does not proceed to completion (i.e. does not result in complete appropriation of the electron pair by the nucleus of one of

the carbon atoms), the polarized form $\overset{\delta-}{\text{C}}-\overset{\delta+}{\text{C}}$ may be considered to arise in which the charges generated are only fractional ones: ordinarily these electromeric changes are supposed to have a very restricted amplitude except in the course of reactions. The negatively charged carbon atom is then in a very unstable and reactive condition, and will seek to restore itself either by reversing the original electromeric change or by external reaction; in the latter case two electrons will be given to an outside molecule or ion, usually for the purpose of forming an ordinary valency link (covalency) with that molecule or ion. The existence of this "donating" tendency on the part of the negatively polarized carbon atom will determine the course of additive reaction, for towards the electron-donating atom of the ethylenic pair, the electron-seeking centres (or electron-seeking ions) of polarized reagent molecules will be attracted and reaction will ensue:

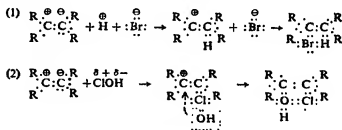

Additive reaction thus arises in virtue of the electron-conferring tendency located at the negatively polarized carbon atom of the ethylenic system and the electron-seeking tendency of reagent molecules: consequently the orienting influence exercised by the groups substituting the ethylenic carbon atoms (i.e. the groups R, R', R', and R'' in an olefine $\text{CRR}':\text{CR}''\text{R}'''$) depends on the influence of these groups in promoting or depressing the fundamental electromeric polarizations (A) and (B) above.

Groups such as alkyl and aryl attached to the ethylenic carbons appear to be capable of rendering one direction of polarization more facile and probable than the other. The mechanism by which the influence of these groups is given effect appears to depend on the unequal sharing (early postulated by G. N. Lewis) of the bonding pair of electrons in unsymmetrical saturated systems such as

Cl—C, CH₃—C, C—O, C—N: the bonding pair is drawn away from one atom of the system towards the other, thus creating a species of electronic strain which not only makes one of the atoms of each system more negative than the other, but is capable of being transmitted in a kind of 'inductive' relay from atom to atom along a chain (e.g. in Cl ← C ← C ← C) until it becomes damped out. In unsubstituted ethylene, owing to its symmetry, polarization must be assumed to occur with equal facility in either direction; but when a hydrogen atom of ethylene is replaced by a methyl group the symmetry is disturbed. In comparing the systems (C) and (D)



since methyl appears generally to have a smaller electron affinity than a hydrogen atom there is an inductive displacement in the direction Me → C = CH₂ and the electrons are all moved to the right hand relatively to the position they would occupy in ethylene or Δ¹-butene, as may be represented by (E). This means that when electromeric displacement occurs, the electromeric change

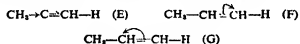

(F) is more likely to be produced than (G).

As regards the relative efficiencies of different groups in initiating those inductive displacements of electrons which by promoting electromeric changes in attached ethylenic systems determine the direction of addition, it appears that the electron-repelling tendency of the lower alkyl groups runs in the order: Pr > Et > Me > H. Aryl groups are generally effective in promoting strong electron displacements in the direction ArCH=CH₂, but such aromatic substituents appear to be capable of a dual role, and in certain special cases the reverse polarization would seem to be possible.

The foregoing generalizations may be regarded as describing the normal additive tendency. It has long been known, however, that the direction of addition of HBr to olefinic substances is often extremely variable, being 'sensitive' apparently to experimental conditions. It has recently been found by Kharasch and his collaborators [45, 1933] that traces of peroxide in the reaction mixture (and many 'pure' olefinic substances normally contain traces of peroxide unless they are specially freed therefrom) can cause inversion of the direction of addition, even to the extent of 100%. Such inversion has been observed only in the case of hydrogen bromide additions, and the effect is much more marked with some olefines than with others; that is to say, some olefines are not very sensitive to peroxide catalysis and need considerable amounts of the catalyst to affect appreciably the direction of addition.

With regard to the influence of the external conditions of reaction—the solvent, temperature, and light—Kharasch claims that these affect only those reactions which are peroxide-catalysed, and have no effect on reactions which are little sensitive to peroxides [44, 1934]. According to this view it is of the utmost importance in considering the effect of external conditions on the course of additive reaction to know beforehand whether or not the unsaturated material is sensitive to peroxides. Peroxides, however, have no effect on the final addition products when once formed, and must owe their effect to their influence on one or both of the reactants before addition has occurred.

Hydration of Olefines by means of Acids.

Sulphuric Acid. The direct addition of water to olefines cannot readily be effected merely by submission of the reactants to heat or pressure, with or without traces of catalysts. Recourse is therefore had to the action of acids. Sulphuric acid, in more or less aqueous condition, can bring about three distinct types of reaction with olefines, viz. (1) hydration, (2) ester formation, and (3) polymerization, all of which may occur side by side. The course of reaction is further complicated by reversibility, which in the case of hydration is of particular importance; in general, however, reaction is influenced by the character of the olefine, the temperature of the reaction, and the concentration and quantity of the acid. At higher temperatures and with stronger acids polymerization may become the chief reaction.

Since the hydration of olefines by means of somewhat diluted sulphuric acid is carried out on a large scale industrially, the direction of addition and the influence of catalysts thereon is of importance. Propene and Δ¹-pentene form esters with 85–92% sulphuric acid, which on subsequent hydrolysis give little in the way of primary alcohols. Δ²-Pentene, on the other hand, gives a mixture of 2- and 3-pentanol [11, 1934]. The direction of addition in these and in other examples is normal and in the case of Δ¹-pentene examination shows that peroxidic substances do not reverse the direction of addition.

Other Acids. Hydration of *isobutene* and of certain pentenes and hexenes by aqueous solutions of formic, acetic, and oxalic acids was first observed by Miklaschewsky [68, 1891]. Later Michael and Brunel [64, 1912] found that in presence of hydrobromic acid of less than 5 N. strength trimethylethylene was converted into the corresponding alcohol only. Trimethylethylene is hydrated by aqueous nitric acid to *tert.*-amyl alcohol; it is also hydrated at measurable rates in dilute aqueous solution by weak as well as strong acids, and at concentrations of 0.1 M. a catalytic influence decreasing in the following sequence has been observed: H₂S₂O₈ > H₂SO₄ > HCl > HBr > HNO₃ > *p*-CH₃·C₆H₄·SO₃H > C₆H₅(NO₂)₂OH > (CO₂H)₂ > C₆H₅(CO₂H)₂ [61, 1934]. The hydration of *isobutene* is also catalysed by dilute nitric acid and the rate at a given acid concentration is increased on the addition of potassium nitrate; it is reported, however, that the specific rate of hydration in 0.2 N. nitric acid is substantially unchanged by certain metallic ions (Cu, Ni, Pb, Hg, &c.) which have been considered to be good hydration catalysts for olefines [60, 1932–4]. The normal butenes are not hydrated at 25° in N. nitric acid, and at elevated temperatures polymerization is a complicating factor.

Pyrolysis.

Most of the primary products of pyrolysis of olefines are susceptible of further change at the temperature of pyrolysis. The nature of the ultimate products is therefore partly determined by secondary effects, which become of increased importance as the higher degrees of decomposition (promoted by higher temperatures or longer contact times) are reached. In general, products of three different degrees of volatility are formed, viz.:

- (1) Products of lower boiling-point than the original hydrocarbon.
- (2) Products of approximately the same boiling-point as the original hydrocarbon, including especially isomeric compounds and dehydrogenation products.

(3) Higher boiling products, especially polymerides and aromatic hydrocarbons.

Products of the third of these types do not arise (except by purely secondary reactions) during the pyrolysis of paraffins: hence the complexity of pyrolysis products from olefines tends to be much greater than of those from paraffins.

Of the five lowest members of the olefine series ethylene is by far the most stable; then follow propene and *isobutene*, and subsequently Δ^1 - and Δ^1 -butene in order of decreasing stability. According to Wheeler and Wood [89, 1930] the principal primary reactions which ethylene, propene, and the two *n*-butenes undergo are polymerization and degradation. These reactions occur side by side and yield 2-carbon or 4-carbon olefines (or both):

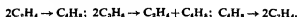

Rapidly, however, they are succeeded by processes of dehydrogenation, and, in the presence of the hydrogen so liberated, hydrogenolytic scission of the carbon chain takes place with formation of methane and the next lower olefine, e.g.

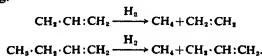

The following decomposition products have been obtained from the five lowest olefines [39, 1934], and it is to be noted (a) that acetylene is not an important product except from ethylene, (b) that allenic products have not been found, and (c) that hydrogen is less important as a reaction product with the higher olefines.

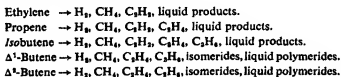

The course of pyrolysis is rendered more complex and difficult to follow by the occurrence of isomerization and skeletal rearrangements. Δ^1 -Butene, for example, becomes partially converted into Δ^2 -butene and vice versa, the two *n*-pentenes (Δ^1 - and Δ^2 -) yield one or more of the isomeric amylenes (chiefly *isopropylethylene*), and other higher olefines behave in analogous ways. Dehydrogenation to yield dienes such as butadiene also occurs.

Polymerization may become an important feature of the pyrolytic process, the lower gaseous olefines yielding volatile liquid products and the higher ones higher-boiling liquids or tars. Aromatic hydrocarbons are important products in the case of pyrolysis conducted at high temperatures, but may be entirely absent where lower temperatures are employed.

Presumably the mechanism of degradation follows a course similar to that which applies to saturated hydrocarbons (see p. 940), but additional complexities occur in the case of olefines, since both C—C and C=C bonds have to be taken into consideration; and although it may be assumed on the basis of customary values for the relative strengths of C—C and C=C bonds that the latter is the stronger (although weaker than the C—H bond), yet the strengths of different single carbon to carbon bonds might reasonably be expected to vary somewhat according as the latter are adjacent to or remote from a double bond.

III. DIOLEFINIC AND POLYOLEFINIC HYDROCARBONS

This group comprises (1) Conjugated Hydrocarbons, in which the unsaturated and saturated centres of the molecules alternate; (2) Allenic Hydrocarbons, in which the unsaturated centres occupy contiguous positions; and (3) Non-conjugated Hydrocarbons, in which the double linkages are separated by more than one single linkage.

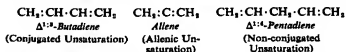

Occurrence. Certain of the hydrocarbons of this group occur naturally: *ocimene*,

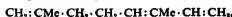

can be extracted from the leaves of *Ocimum basilicum*, *myrcene*,



from oil of bay, *squalene*,



from the livers of elasmobranch fish, and numerous long-chain, highly unsaturated (conjugated) hydrocarbons are comprised in the carotene group of plant pigments.

Butadiene occurs in appreciable amounts in the lower fractions of cracked petroleum, and *cyclopentadiene* is an important constituent of the forerun of the benzene derived from coal tar. For the most part, however, the hydrocarbons of the group are obtained by synthetic means.

1. Conjugated Dienes and Polyenes

Preparation.

The conjugated diolefines are obtained by numerous elimination reactions in which the elements of water, hydrogen halide, alkylamines, &c., or 2 atoms of halogen are removed from suitable glycols, unsaturated alcohols, dihalogeno-paraffins, halogeno-olefines, alkylamino-olefines, di-alkylamino-paraffins, &c. In the case of amines and alkylamines the amino-groups are first converted into the quaternary ammonium condition (hydroxide or salt) by exhaustive methylation and then eliminated as trialkylamines by distillation of the ammonium compound. These methods are typified by the following reactions in which the nature of the eliminating agency (frequently heat, facilitated in its action by the presence of a catalyst or a contact reagent) is indicated:

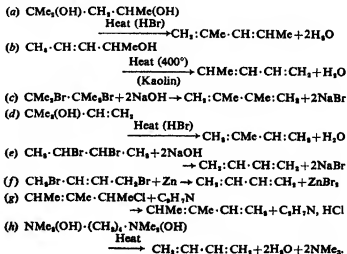

Unsaturated alcohols suitable for direct dehydration to hydrocarbons can be synthesized in great variety, and usually very conveniently, by the Grignard method.

In certain cases, as occurs with saturated alcohols, elimination can take more than one course, and in such cases mixtures of hydrocarbons will be produced: for example, a small proportion of the diene $\text{CMe}_2\text{:CH:CH:CH}_2$ is produced side by side with the major product $\text{CH}_2\text{:CMe:CH:CHMe}$ in the reaction (a) [28]; also all of the three possible ways of elimination are realized to some extent in the dehydration of dimethyl-propenyl-carbinol [28], represented in (i),

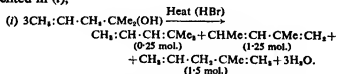

Dienes are formed in numerous pyrolytic decompositions of hydrocarbons, alcohols, and similar substances, and various processes have been devised for the preparation of dienes in this way. Piperylene is obtained by passing a mixture of acetaldehyde and isopropyl alcohol over heated alumina, butadiene by thermal decomposition of butyl alcohol, and isoprene by thermal decomposition of isomyl alcohol, limonene, or rubber; but in nearly all such processes the yields of diene are small.

Physical Properties. With the exception of butadiene, which is gaseous at the ordinary temperature, the well-known aliphatic and alicyclic dienes and polyenes are volatile liquids of low density, which show in general a more

or less marked tendency to polymerize; certain substituted dienes and polyenes, more particularly the aryl-substituted compounds, are crystalline solids. The molecular refraction of the open-chain dienes and polyenes (except in the case of poly-halogeno-compounds) shows marked exaltation, but the dielectric constants of the members of this group differ little from those of the corresponding paraffins and ethylenes.

Many of the compounds of this group can display geometrical isomerism, and a number of isomerides of this type have been obtained; in the case of liquid hydrocarbons, however, geometrical isomerides are difficult to separate,

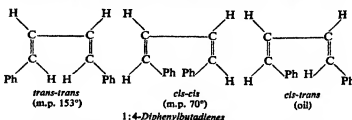

but the range of boiling-point of synthetic specimens frequently indicates that such isomerides are present. In certain cases, however, as seen above, the non-homogeneity of synthetic specimens derived by elimination reactions is due to the presence of structural isomerides.

The following tables give the chief physical constants of many of the known conjugated dienes and polyenes, together with the melting-points of the maleic anhydride and α -naphthaquinone derivatives of the former, so far as they

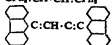

Conjugated Dienes (Open-chain)

Hydrocarbon	Formula	B.p. (m.p.)*	d_4^{20}	n_D^{20}	MR _D	Maleic anhydride compound m.p.	α -Naphthaquinone compound m.p.
Butadiene (Erythrene, Divinyl)	$\text{CH}_2\text{:CH:CH:CH}_2$	-5-4°/713 mm.	103-4°	102-3°
1-Methyl-butadiene (Piperylene)	CHMe:CH:CH:CH_2	42.4-62°/766 mm.	0.6803	1.4309	25.89	62°	..
2-Methyl- " (Isoprene)	$\text{CH}_2\text{:CMe:CH:CH}_2$	33.9-35.3°/750 mm.	0.6806	1.4207	25.34	63-4°	..
2-Chloro- " (Chloroprene)	$\text{CH}_2\text{:CCl:CH:CH}_2$	39-4°/760 mm.	0.9563	1.4583	25.27
2-Bromo- " (Bromoprene)	$\text{CH}_2\text{:CBr:CH:CH}_2$	42-3°/165 mm.	1.397	1.4988	27.94	186.5-187†	138*
2-Iodo- " (Iodoprene)	$\text{CH}_2\text{:CI:CH:CH}_2$	111-13°/760 mm.	..	1.561
2-n-Butyl- " (Butoprene)	$\text{CH}_2\text{:CnBu:CH:CH}_2$	121-3°/760 mm. ‡	63-4°
2-tert-Butyl- " (tert-Butoprene)	$\text{CH}_2\text{:C(CMe}_2\text{):CH:CH}_2$	104-6†	123.5-124°	89.5-90°
2-n-Heptyl- " (Heptoprene)	$\text{CH}_2\text{:C(C}_7\text{H}_{15}\text{):CH:CH}_2$	52-4°/15 mm.	0.7796	1.4511	52.52	..	81*
1-Phenyl- "	CPh:CH:CH:CH_2	90°/15 mm.	0.9286	1.6089 ^{§§}	..	120°	..
2-Phenyl- "	$\text{CH}_2\text{:CPh:CH:CH}_2$	60-1°/17 mm.	0.9226	1.5489	44.93	105-105.5°	146-7°
1,1-Dimethyl-butadiene	$\text{CMe}_2\text{:CH:CH:CH}_2$	76.2-76.6°/758 mm.	0.7183	1.4525	30.86
1,2-Dimethyl- "	CHMe:CH:CH:CH_2	76.0-79.4°/773 mm.	0.7279	1.4511	30.37	67°	..
1,3-Dimethyl- "	CHMe:CH:CMe:CH_2	75.6-75°/763 mm.	0.7196	1.4467	30.46	56†	..
1,4-Dimethyl- "	CHMe:CH:CH:CHMe	79.4-81.6°/765 mm.	0.7152	1.4493	30.8	95-5°	..
2,3-Dimethyl- "	$\text{CH}_2\text{:CMe:CMe:CH}_2$	68.8°/750 mm.	0.7262	1.4394	29.75	78-9°	..
1-Methyl-2-chloro-butadiene	CHMe:CCl:CH:CH_2	99.5-101.5°/759 mm.	0.9576	1.4785	30.32	..	181*
1-Ethyl-2-chloro- "	CHEt:CCl:CH:CH_2	68.2-69.0°/117 mm.	0.9390	1.4770	35.05	..	151-2°
1-n-Butyl-2-chloro- "	CHnBu:CCl:CH:CH_2	64-5°/18 mm.	0.9166	1.4794	43.77	..	120-30*
1-n-Heptyl-2-chloro- "	$\text{CH(C}_7\text{H}_{15}\text{):CCl:CH:CH}_2$	74-6°/1 mm.	0.9141	1.4785	57.79	..	112.5-113.5°
2,3-Dichloro- "	$\text{CH}_2\text{:CCl:CCl:CH}_2$	98°/760 mm.	1.1829	1.4890	30.21
2,3-Di-tert-butyl- "	$\text{CH}_2\text{:C(CMe}_2\text{):C(CMe}_2\text{):CH}_2$	168-70° (37°)	0.7754 ^{§§}	1.4365	56.03	128-9°	..
1-Phenyl-3-methyl- "	CPh:CH:CMe:CH_2	116°/16 mm.	0.9469 [§]	1.5766 ^{§§}
1-Phenyl-4-methyl- "	CPh:CH:CH:CMe	116°/16 mm.	0.9325 ^{§§}	1.6111 ^{§§}	..	158-9°	..
1,4-Diphenyl- "	CPh:CH:CH:CPh	116°/16 mm. (152°) (70°); oil (49°) (79°)	81-86§	207*
2,3-Diphenyl- "	$\text{CH}_2\text{:CPh:CPh:CH}_2$
1,4-Dibenzyl- "	$\text{Ph:CH:CH:CH:CH}_2\text{:CH:CH}_2\text{:Ph}$
1,1:3-Trimethyl- "	$\text{CMe}_2\text{:CH:CMe:CH}_2$	92°/749 mm.
1,1:4-Trimethyl- "	$\text{CMe}_2\text{:CH:CH:CMe}$	97-9°
1,2:3-Trichloro- "	CHCl:CCl:CCl:CH_2	33-47°/7 mm.	1.4060	1.5262	34.39
1,2:3:4-Tetramethyl- "	CHMe:CMe:CMe:CHMe	132-4°	0.7832 ^{§§}	1.4630 ^{§§}
1,4-Dimethyl-2:3-diethyl-butadiene	CHMe:CEt:CEt:CHMe	155-55°
1:2:3:4-Tetra-phenyl- "	CPh:CPH:CPH:CPh	(183-4°)	90-1°	91-2*
1:3:4:4-Tetra-phenyl- "	$\text{CPh}_3\text{:CH:CH:CPh}_2$	(202°)
1,4-Di-biphenylene-	 C:CH:C:C	Sublimes 360°

* Where the hydrocarbon is a solid the m.p. is given in brackets.
 ‡ Somewhat impure.
 § MR_D (in chloroform).

† Hydrated anhydride.

Conjugated Trienes and Polyenes

Hydrocarbon	Formula	M.p. (d.p.)
$\Delta^{1,3,5}$ -Hexatriene	$\text{CH}_2=\text{CH}=\text{CH}=\text{CH}=\text{CH}_2$	(80°)
1:6-Diphenyl-hexatriene	$\text{Ph}-(\text{CH}=\text{CH})_2-\text{Ph}$	200°
1:6-Dibenzyl-hexatriene	$\text{Ph}-\text{CH}_2-(\text{CH}=\text{CH})_2-\text{CH}_2-\text{Ph}$	68°
1-Biphenylene-6-phenyl-hexatriene	 $\text{CH}=\text{CH}-(\text{CH}=\text{CH})_2-\text{Ph}$	155-5°
1:4-Di-biphenylene-hexatriene	 $\text{C}=\text{CH}=\text{CH}=\text{CH}=\text{C}$	Sublimes 360°
1:8-Diphenyl-octatetraene	$\text{Ph}-(\text{CH}=\text{CH})_2-\text{Ph}$	232°
1:8-Dibenzyl-octatetraene	$\text{Ph}-\text{CH}_2-(\text{CH}=\text{CH})_2-\text{CH}_2-\text{Ph}$	109-10°
1-Biphenylene-8-phenyl-octatetraene	 $\text{C}=\text{CH}-(\text{CH}=\text{CH})_2-\text{Ph}$	166°
1:10-Diphenyldodecapentaene	$\text{Ph}-(\text{CH}=\text{CH})_2-\text{Ph}$	253°
1:12-Diphenyldodecahexaene	$\text{Ph}-(\text{CH}=\text{CH})_2-\text{Ph}$	267°
1:14-Diphenyltetradecaheptaene	$\text{Ph}-(\text{CH}=\text{CH})_2-\text{Ph}$	279°
1:16-Diphenylhexadecaoctaene	$\text{Ph}-(\text{CH}=\text{CH})_2-\text{Ph}$	285°

are known. The formation of these latter derivatives furnishes the best-known means for the characterization of the hydrocarbons of this group.

Addition Reactions.

The conjugated dienes and polyenes yield addition products with three types of addenda, viz. (1) with symmetrical molecules such as bromine, (2) with unsymmetrical molecules such as hydrogen bromide, and (3) with non-dividing molecules such as maleic anhydride. With addenda of the first two types, 2 molecules of the reagent can be added in turn, but sometimes the second molecule reacts only slowly or incompletely. The ease of addition depends largely on the nature of the substituent groups in the conjugated system.

1. **Symmetrical Addenda.** (1) *The Halogens.* Addition of the halogens (Cl_2 , Br_2 , and sometimes I_2) can in general occur either at the 1:2- or at the 1:4-positions, and in some cases a mixture of 1:2- and 1:4-dihalides is produced.

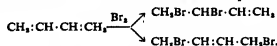

The mode of addition varies from one hydrocarbon to another, the positions taken up by the halogen atoms being to a large degree dependent on the constitution of the conjugated body. The composition of the halogenation product can, however, vary in well-observed examples to an important extent with changes in the experimental conditions of reaction (nature of solvent, concentration, temperature, and presence or absence of catalysts), possibly owing in some degree to isomerization of less stable dihalides into more stable forms. The presence of traces of peroxide in *cyclopentadiene* has been observed to inhibit to a serious extent the addition of bromine [80, 1934].

Since in certain additions to conjugated dienes and polyenes both 1:2- and terminal forms are produced side by side, these products being often to a greater or smaller extent interconvertible by spontaneous change, heat, or by catalyst action, it has been supposed that addition leads in the first place to the production of ions (cations) formed by the addition of one atom of halogen to the conjugated molecule:

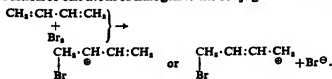

II

These ions, which correspond to the 1:2- and the terminal products of the completed reaction, are tautomericly related to one another and tend to undergo interconversion with the ultimate establishment of a condition of equilibrium before they finally add the second atom (ion). The general course of reaction has been formulated as follows [17, 1928-9], the position of equilibrium being determined largely by the substituents present in the diene:

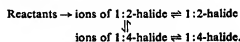

There is now no question that in some cases the 1:2- and in others the terminal dihalide may appear as a primary product of addition; moreover, one or other of these forms may constitute the *sole* primary product of reaction. There is also no question that in some cases (but by no means in all) one dihalide or the other is capable after formation of undergoing more or less complete conversion into its isomeric—readily by spontaneous change or catalyst action, or with greater difficulty on heating. This type of isomerization is known as 1:3- or *xy*-change, or, on the assumption that the underlying mechanism is an ionic one, as anionotropic change, the migrating atom or group being negatively charged. The conclusion, however, that the isomeric products of reaction necessarily or even usually are present together immediately addition is ended in a condition of stable equilibrium, as is implied in the above scheme, is contrary to observation.

(2) *Hydrogen.* In the presence of metallic catalysts such as finely divided platinum, palladium, or activated nickel, hydrogen adds to the conjugated diolefines to give di- and tetra-hydrogenation products. Addition may proceed selectively as between the unsaturated centres of the molecule or it may proceed terminally; but usually, not only are step-wise hydrogenations of these kinds effected, but some measure of addition at both double bonds simultaneously occurs unpreventably, giving saturated hydrocarbons. Thus an unsymmetrical diene of the type $\text{CRR}^1:\text{CR}^2:\text{CR}^3$ may in general be expected to yield 4 products on dihydrogenation, viz. the 1:2-, 3:4-, and 1:4-dihydro-compounds and some proportion of the corresponding 1:2:3:4-tetrahydro-compound. The proportions in which the 4 types of product are formed have been observed to vary considerably with changes in the nature and degree of substitution in the diene chain; probably also they depend on

I

Partial Hydrogenation Products of Dienes [58] (1 Mol. of Hydrogen)

Butadiene* CH ₂ :CH:CH:CH ₂	Piperylene* CHMe:CH:CH:CH ₂	Isoprene CH ₃ :CMe:CH:CH ₂	2:3-Dimethylbutadiene CH ₃ :CMe:CMe:CH ₂
Butadiene . . . 34	Piperylene . . . 32	Isoprene . . . 30	2:3-Dimethylbutadiene . . . 28
Butane . . . 34	Pentane . . . 32	isoPentane . . . 30	2:3-Dimethylbutane . . . 28
Δ ¹ -Butene . . . 23	Propylethylene . . . 10	isoPropylethylene . . . 12	as-Methylisopropylethylene . . . 27.4
Δ ² -Butene . . . 9	s-Methylethylethylene . . . 26	as-Methylethylethylene . . . 13	Tetramethylethylene . . . 16.6
		Trimethylethylene . . . 15	

* Approximate proportions.

the degree of activity of the catalyst, as has been noted in the case of butadiene- α -carboxylic acids.

II. Unsymmetrical Addenda. (1) *Hydrogen Halides*. Hydrogen chloride, hydrogen bromide, and hydrogen iodide add to dienes in such a way that the first step appears to involve the attachment of the hydrogen atom (proton) to one of the terminal atoms of the system. Thus in the case of an unsymmetrical diene the formation of different proportions of 4 isomeric hydrohalides may in general be anticipated:

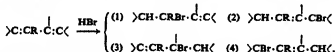

Usually a second molecule of hydrogen halide may be added, the orientation being then determined by the factors which govern mono-olefinic additions.

(2) *Hypohalous Acid*. Hypochlorous and hypobromous acids yield mono- and di-halogenohydrins with conjugated dienes, the addendum dividing in the manner Cl \cdot ...OH or Br \cdot ...OH. Monohalogenohydrins of both the types I and II are known to be formed from unsymmetrical dienes; but the formation of

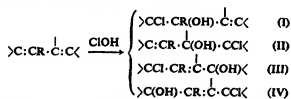

terminal compounds of the types (III) and (IV), or indeed of others of the theoretically possible forms, has not been established.

(3) *Water*. Dienes are not readily hydrated by direct treatment with water. Mixtures of acetic acid and sulphuric acid, however, react with dienes and give, in the case of isoprene, the acetic esters and the ethers of a variety of open-chain and cyclic alcohols which appear to be formed mainly from the hydration products of the dimeric and trimeric forms of the hydrocarbon [88, 1932]. 2:3-Dimethylbutadiene behaves towards the acetic acid-sulphuric acid mixture analogously [28].

(4) *Nitrogen Trioxide, Nitrogen Peroxide, Nitrosyl Chloride, and Sulphur Chloride*. The conjugated dienes, like the mono-olefines, yield addition compounds with the oxides of nitrogen and nitrosyl chloride. Thus 1:4-diphenylbutadiene yields a terminal addition product, Ph-CH(NO₂)-CH:CH-CH(NO₂)-Ph, with nitro-

gen peroxide. Additive products are also obtained with sulphur dichloride.

III. Non-dividing Addenda. (1) *Maleic Anhydride, Benzoquinone, α -Naphthoquinone, Acrolehyde, Acrylic Esters, &c.* These and other substances containing the group -CH:CH:CO- react readily with dienes, trienes, and polyenes at room temperature or 100° yielding addition products which are invariably derivatives of cyclohexene [23, 1928-9]. The simplest case is that of the addition of maleic anhydride to a diene, in which by the addition of the ethylenic system of the latter at the terminals of the former a cyclohexene ring is formed:

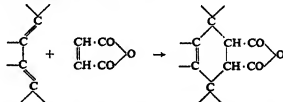

The anhydro-cyclohexenes so obtained and the dicarboxylic acids formed therefrom on hydration are crystalline substances which are especially suitable for the characterization of the hydrocarbons; moreover, with certain of the simpler dienes the yield of addition product is quantitative and the addition affords a means of ascertaining the degree of structural homogeneity (not homogeneity of geometrical form) inherent in hydrocarbon specimens. For the characterization of conjugated hydrocarbons the addition products obtained with α -naphthoquinone are also serviceable.

Trienes react in similar fashion to dienes to give vinyl- or ethylenic-cyclohexene derivatives [29, 1929] and polyenes to give addition products at both ends of the hydrocarbon system [50, 1930]:

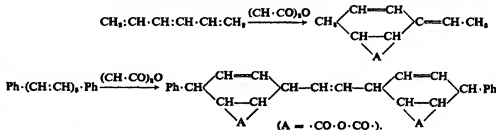

Benzoquinone unites with 1 or with 2 molecules of a diene to yield tetrahydronaphthoquinones or octahydroanthraquinones:

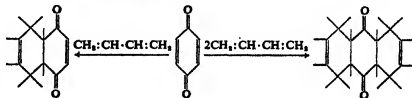

and in the case of cyclic dienes bridged derivatives of tetrahydronaphthaquinone or octahydroanthraquinone are formed:

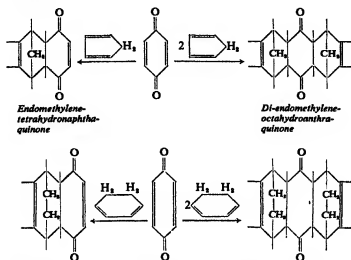

Many of the hydronaphthaquinones and hydroanthraquinones produced in these additions can be smoothly oxidized (dehydrogenated) to the corresponding naphthaquinones and anthraquinones.

(2) *Sulphur Dioxide*. The dienes unite with sulphur dioxide to yield cyclic sulphones [26, 1907, 1930-1, 1934]. Thus isoprene yields isoprene sulphone (2-methyl- Δ^2 -butene-1:4-sulphone):

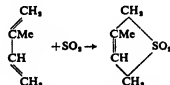

Isoprene sulphone and those of its analogues which are substituted at the 2-carbon atom undergo isomerization when submitted in alkaline solution to ultra-violet light; sulphones, however, which are substituted at both the 2- and 3-carbon atoms do not undergo isomerization. The isomeric sulphones are regarded as differing from one another in spatial configuration (*cis*- and *trans*-forms).

Substituted butadiene	M.p. of sulphone (° C.)	Substituted butadiene	M.p. of sulphone (° C.)
2-Methyl-	63-63.5	2-Phenyl-	132.5-133.5
2:3-Dimethyl-	135	2:3-Di- <i>tert</i> -butyl-	69-70
1:2:3:4-Tetramethyl-	58-9	2:3-Diphenyl-	183-4
1:4-Dimethyl-2:3-diethyl-	45	2-Chloro-3-methyl-	120-120.5
2- <i>tert</i> -Butyl-	82-3		

(3) *Selenium Dioxide*. Cyclic selenones analogous to the cyclic sulphones are formed easily at the ordinary temperature by direct addition of selenium dioxide in chloroform to various dienes [5, 1934]. Thus isoprene yields a selenone of m.p. 67°, whilst 2:3-dimethylbutadiene (66°), 2-*tert*-

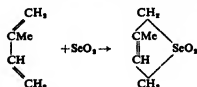

butylbutadiene (81-2°), 2-phenylbutadiene (90°), 2:3-diethylbutadiene (132°), 2:3-diphenylbutadiene (89-90°),

2-chloro-3-methylbutadiene (110° c.) yield selenones which melt at the temperatures given in the brackets.

(4) *Oxygen and Ozone*. Most of the diene and polyene hydrocarbons absorb oxygen to yield peroxides. In the distillation of hydrocarbons which have been exposed to the air the peroxide content may give rise to violent explosions towards the end of the operation. Bodendorf [10, 1933] reports that conjugated cyclic dienes are oxidized by oxygen without a catalyst much more rapidly than are mono-olefinic compounds, and the products are multi-molecular peroxides of the type (I) derived from $\Delta^{1,2}$ -cyclohexadiene.

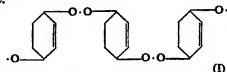

Ozonides are likewise formed by the addition of ozone at one or more of the unsaturated centres of the hydrocarbons. The structures of the individual peroxidic and ozonide groups resemble those of the mono-olefines. Both peroxides and ozonides appear to act as effective catalysts for the polymerization of dienes and polyenes.

Dienes and Polyenes (Non-conjugated)

The best-known substances in this group are the symmetrical diolefines obtained by the action of sodium on halogeno-olefines of the type $\text{R} \cdot \text{CH} : \text{CH} \cdot \text{CH}_2\text{I}$ or $\text{R}' \cdot \text{CH} : \text{CR}' \cdot \text{CH}_2\text{I}$ ($\text{R} = \text{H}$ or alkyl).



Unsymmetrical diolefines are obtained by elimination and dehalogenation reactions similar to those employed in the preparation of the conjugated dienes.

The non-conjugated dienes resemble the mono-olefines in their general physical and chemical properties: their molecular refraction, however, shows no exaltation, and they can unite with 1 or with 2 molecules of halogens, hypochlorous acid, and other additive reagents. They readily undergo catalytic hydrogenation, frequently in a well-defined step-wise manner, and are converted by sulphuric acid into oxides. The dienes and polyenes are susceptible to atmospheric oxidation and many polymerize spontaneously.

Non-conjugated Dienes

	B.p. (° C.)
Diallyl ($\Delta^{1,2}$ -Hexadiene)	59.3
Dicrotyl ($\Delta^{2,3}$ -Octadiene)	117-19
Di-isocrotyl (2:5-Dimethyl- $\Delta^{1,2}$ -hexadiene)	113-14

Allenes, $\text{R}_2\text{C} : \text{C} : \text{R}_2$

The allenes are diolefinic hydrocarbons in which the double bonds are adjacent to one another. They have been obtained by the isomerization of certain of the alkyl-acetylenes on heating, but they are prepared by the following methods:

- (1) by the action of potash or alcoholic potash at 130° on bromo-paraffins of the types $\text{CR}_2 : \text{CBrR}$ and $\text{CR}_2 : \text{CBr} \cdot \text{CR}$ ($\text{R} = \text{alkyl}$), or on dibromo-paraffins of the type $\text{CR}_2 \cdot \text{CBr} \cdot \text{CHRBr}$;
- (2) by the action of phosphorus pentachloride on ketones of the type $\text{CHR}_2 \cdot \text{CO} \cdot \text{CHR}_2$ ($\text{R} = \text{alkyl}$) followed by elimination of hydrogen chloride from the product by means of alcoholic potash at 130°;

(3) by the action of zinc dust and alcohol on dibromo- or dichloro-olefines of the type CHR:CBR-CHBr.

When heated with sodium or potassium they are reported to give metallic derivatives of isomeric acetylenes, or when heated with the same metals in the presence of carbon dioxide, the corresponding acetylene-carboxylic acids.

Except for allene, which is a gas, the members of the group are colourless liquids of garlic-like odour.

Allenic Hydrocarbons

Hydrocarbon	Formula	B.p. (°C.)
Allene	CH ₂ :C:CH ₂	-32
Methylallene	CHMe:C:CH ₂	18-19
Ethylallene	CHEt:C:CH ₂	45
<i>n</i> -Dimethylallene	CHMe ₂ :C:CHMe	49-51
<i>n</i> -Propylallene	CHPr ⁿ :C:CH ₂	39.5-40.5
<i>iso</i> Propylallene	CHPr ⁱ :C:CH ₂	78
Trimethylallene	CMe ₃ :C:CHMe	70
1-Methyl-1-ethylallene	CMeEt:C:CH ₂	71.5-72.5
<i>n</i> -Butylallene	CHBu ⁿ :C:CH ₂	70-1
<i>iso</i> Butylallene	CHBu ⁱ :C:CH ₂	106
<i>tert</i> -Butylallene	CHBu ^t :C:CH ₂	96
<i>ns</i> -Diethylallene	CMe ₂ :CH:C:CH ₂	80-3
Tetramethylallene	CEt ₄ :C:CH ₂	97
	CMe ₂ :C:CMe ₂	86-5

Reactions.

The allenes can add 1 or 2 molecules of halogen, halogen acid, or hypochlorous acid, but undergo catalytic hydrogenation somewhat less readily than do other olefines. With an unsymmetrical addendum, such as hypochlorous acid or hydrogen bromide (1 mol.), all four of the possible ways of addition to the two double bonds of the allene system appear to occur to some extent. For the most part, however, so far as present results show, additive attack begins at the central carbon atom of the system, giving in the case of unsymmetrical allenes chiefly products of the type CRR'(OH).CCL:CH₂ with hypochlorous acid and CRR':CH.CH₂Br with hydrogen bromide. It is to be observed, however, that the systems R₂C.CCL:CH₂ and R₂C.CH:CH₂, representing probably the first stage of addition of ClOH and HBr respectively to the allene (cf. p. 949), are potentially tautomeric, possessing the structure necessary to the occurrence of α -change (R₂C.CCL:CH₂ \rightleftharpoons R₂C:CCl.CH₂), so that distinction between the primarily and secondarily formed mono-addition products of allenic hydrocarbons presents the same difficulty that occurs with the mono-addition products of conjugated dienes and polyolefines. The mono-addition products of the allenes are mono-olefinic substances and behave as such to additive reagents.

The allenes polymerize on heating, giving dimerides and higher polymerides (see p. 966).

Olefin-allenes and Allenic Trienes.

Derivatives of vinylallene and a chloro-vinyl-butatriene (3-chloro- $\Delta^{1:2:4:5}$ -hexatetraene) have been derived from divinylacetylene [18, 1933].

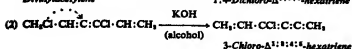
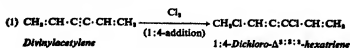

IV. ACETYLENIC HYDROCARBONS

Acetylenes, C_nH_{2n-2}

In this group are included acetylene, CH:CH, and its mono- and di-substitution products, CH:CR and CR:CR', all of which contain a pair of carbon atoms joined by a triple linkage.

Preparation. The acetylenes are prepared by the removal of hydrogen halide from olefin dihalides, R-CHX-CHX'R', monohalogeno-olefines, R-CX:CH-R', or ketone chlorides, R-CH₂.CCl₂.R' (X = Cl, Br, I), by the action of alcoholic potash, or often conveniently with sodamide.

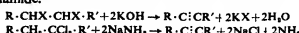

Acetylene, the parent compound of the group, is prepared on a large scale industrially by the action of water on calcium carbide.

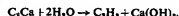

Homologous acetylenes can be prepared by the action of alkyl halides or esters of *p*-toluenesulphonic acid on sodium acetylide, or by the action of calcium carbide on the vapours of alcohols at temperatures above 100°.

Properties. Acetylene is a gas which when pure possesses an agreeable odour. It liquefies at +1° under a pressure of 48 atm. and passes into the solid form when the liquid vaporizes rapidly: solid acetylene sublimates at -82°. Acetylene is liable to explode if compressed in cylinders, but it can be safely stored dissolved in acetone in which it is readily soluble. The aliphatic acetylenes are for the most part liquids of characteristic odour, but the lower members are gaseous at room temperature. The lower arylacetylenes and cyclohexylacetylenes are also volatile liquids.

Acetylenic Hydrocarbons

Substituted acetylene	Formula	B.p. (°C.)	M.p. of mercury derivative (CR'.C ₂ H ₂ (°C.))
Methyl	CMe:CH	-23.3	203-4
Dimethyl	CMe:CMe	28	..
Ethyl	CEt:CH	8-6	162-3
<i>n</i> -Propyl	CPr ⁿ :CH	48-9	118.4-118.8
<i>iso</i> Propyl	CPr ⁱ :CH	28-9	..
Methyl-ethyl	CMe:CEt	55.5-56	..
<i>n</i> -Butyl	CBu ⁿ :CH	70.5-72	96.2-96.4
Methyl- <i>n</i> -propyl	CMe:CPr ⁿ	83-4	..
<i>n</i> -Amyl	C ₅ H ₁₁ :C:CH	99	61
Methyl- <i>n</i> -butyl	CMe:CBu ⁿ	111-13	..
Ethyl- <i>n</i> -propyl	CEt:CPr ⁿ	105-6	..
<i>n</i> -Hexyl	C ₆ H ₁₃ :C:CH	131-2	80.4-80.7
Methyl- <i>n</i> -amyl	CMe:C ₅ H ₁₁	133-4	..
Ethyl- <i>n</i> -butyl	CEt:CBu ⁿ	131-2	..
<i>n</i> -Heptyl	C ₇ H ₁₅ :C:CH	160	67.6-68.5
Methyl- <i>n</i> -hexyl	CMe:C ₆ H ₁₃	161	..
Ethyl- <i>n</i> -amyl	CEt:C ₅ H ₁₁	155-7	..
<i>n</i> -Octyl	C ₈ H ₁₇ :C:CH	80-2 (27 mm.)	83-4
Ethyl- <i>n</i> -hexyl	CEt:C ₆ H ₁₃	175-6	..
<i>n</i> -Propyl- <i>n</i> -amyl	CPr ⁿ :C ₅ H ₁₁	74-5 (19 mm.)	..
<i>n</i> -Nonyl	C ₉ H ₁₉ :C:CH	210-15	79-79.3
Methyl- <i>n</i> -amyl	CMe:C ₅ H ₁₁	195-6	..
<i>n</i> -Decyl	C ₁₀ H ₁₉ :C:CH	95-7 (15 mm.)	84.3-85.1
Di- <i>n</i> -amyl	C ₅ H ₁₁ :C:C ₅ H ₁₁	103-4 (14 mm.)	..
Phenyl	CPh:CH	140.5-141	124.5-125
Phenyl-methyl	CPh:CMe	185	..
Phenyl-ethyl	CPh:CEt	201-3	..
Di-phenyl	CPh:CPh	m.p.	..
Benzyl	Ph.CH ₂ :C:CH	69.5-70 (18 mm.)	106.5-107.5

Substitution Reactions.

(1) Acetylene contains 2 hydrogen atoms which are replaceable by metals; the monoalkyl-acetylenes contain only 1 such replaceable atom.

Isomerization.

Acetylenes are reported to undergo isomerization by migration of the triple bond when heated with sodamide, soda lime, sodium, or even alcoholic potash. Rearrangements of the types (1) and (2) and the reverse reactions also are stated to occur, but the evidence is somewhat contradictory [30, 1888].



Probably some of the alleged changes are isomerizations of acetylenes into allenes, since methylacetylene is known to change easily into allene at 550°, and *tert.*-butyl-benzohydrilacetylene passes into 1-*tert.*-butyl-3:3-diphenylallene on distillation.

Diacetylenes and Triacetylenes

The members of this group contain two acetylenic linkages which may be conjugated or non-conjugated.

Conjugated Diacetylenes.

Preparation. The simplest compound of the series, diacetylene, is prepared either by the action of alcoholic potash on butadiene tetrabromide, or by heating the precipitate formed on adding warm ammoniacal cuprous chloride to ammonium diacetylenedicarboxylate with potassium cyanide. Various symmetrical dialkylacetylenes have been obtained by the action of iodine (2 atoms) on acetylenic Grignard reagents of the type $\text{CR}:\text{CMgX}$ (2 mols.):



Properties. The aliphatic diacetylenes are mobile liquids of characteristic odour. Diacetylene itself contains 2 hydrogen atoms replaceable by metals, and therefore can yield metallic derivatives; the dialkyl-diacetylenes, on the other hand, cannot yield metallic derivatives. All members of the group display well-marked additive properties, and owing to the conjugated arrangement of the triple bonds terminal addition can occur: thus *s*-diphenyldiacetylene on hydrogenation undergoes 1:4, 1:2:3:4, and 1:1:4:4-addition simultaneously.



Conjugated Diacetylenes, R:C:C:C:C:R

Hydrocarbon	M.p. (° C.)	B.p. (° C.)
Diacetylene	-36	9.5
Dimethyl-diacetylene	-64	130
Di- <i>n</i> -propyl-	..	88 (12 mm.)
Di- <i>n</i> -butyl-	..	103 (8 mm.)
Di- <i>n</i> -amyl-	..	118-19 (4 mm.)
Diphenyl-	86.5-87	..
Dibenzyl-	101	..
Di-2-phenylethyl	118	..

Non-conjugated Diacetylenes.

Fairly numerous representatives of this group have been obtained. These are typified by dipropargyl,



(m.p. -8°, b.p. 85°), a mobile liquid of penetrating odour, and are prepared by heating the corresponding diolefin tetrahalides with aqueous or alcoholic potash. Dipropargyl is of interest as being an isomeride of benzene.

Those non-conjugated diacetylenes in which the acetylenic linkages are terminally situated contain hydrogen atoms which are replaceable by metals. Other diacetylenes yield no metallic derivatives. All the diacetylenes display additive properties characteristic of the simple acetylenes.

Triacetylenes.

Several members of the triacetylene group have been reported, e.g. 1-phenyltriacetylene, $\text{CPh}:\text{C}:\text{C}:\text{C}:\text{CH}$, a liquid of b.p. 52° (18 mm.), and 1-iodotriacetylene, $\text{CI}:\text{C}:\text{C}:\text{C}:\text{CH}$, a solid of m.p. 52°.

Olefine-acetylenes

Many hydrocarbons are known which contain both olefinic and acetylenic linkages, arranged either in conjugated or in non-conjugated fashion. The most important compounds of the group are vinylacetylene, $\text{CH}_2:\text{CH}:\text{C}:\text{CH}$, and divinylacetylene, $\text{CH}_2:\text{CH}:\text{C}:\text{C}:\text{CH}:\text{CH}_2$, produced by the polymerization of acetylene at low temperatures in the presence of ammonium and cuprous chlorides (see p. 965). A tetrameride of acetylene, probably possessing the constitution $\text{CH}_2:\text{CH}:\text{C}:\text{C}:\text{CH}:\text{CH}:\text{CH}:\text{CH}_2$, is formed at the same time.

Hydrocarbons of the type $\text{CH}_2:\text{CH}:\text{C}:\text{CR}$ are obtained by the action of alkyl halides on sodium vinylacetylide, and hydrocarbons of the type $\text{CHR}:\text{CR}':\text{C}:\text{CH}$ by the action of alkenyl halides on metallic acetylides.

Olefine-acetylenes

$\text{CH}_2:\text{CH}:\text{C}:\text{CR}$	B.p. (° C.)	d_4^{20}	n_D^{20}
R = H	Liquid*	0.705 ¹⁵ ₄	..
R = Me	59.2 (760 mm.)	0.7401	1.4496
R = Et	84.5-85.3 (758 mm.)	0.7492	1.4522
R = Bu ⁿ	62-3 (61 mm.)	0.7830	1.4592
R = C ₁₀ H ₁₉	74.5 (9 mm.)	0.7962	1.4606
R = C ₁₈ H ₃₅	m.p. 134.5
R = CHEt:CP ⁿ	57-8 (6 mm.)	0.8047	1.4949
$\text{R}:\text{C}:\text{CH}$	B.p. (° C.)	d	n_D^{20}
R = CH ₂ :CMe	32-5	0.6801 ¹⁵ ₄	..
R = CHMe:CMe	67-9	..	1.4332
R = 	148-51	..	1.4922
$\text{R}:\text{C}:\text{C}:\text{R}$	B.p. (° C.)	d	n_D
R = CH ₂ :CH	83.5 (760 mm.)*	0.7851 ²⁰ ₄	1.504 ²⁰ ₄
R = CH ₂ :CMe	123-4	0.7898 ¹⁵ ₄	1.4859 ¹⁵ ₄
R = CHMe:CMe	170	0.8071 ²² ₄	1.4977 ²² ₄
R = CHEt:CP ⁿ	125-7 (18 mm.)	0.8131 ¹⁵ ₄	1.4899 ¹⁵ ₄
R = CHBu ⁿ :CMe	95.8 (0.5 mm.)	0.8241 ²⁰ ₄	1.4866 ²⁰ ₄

* Explosive.

Reactions.

Additive Reactions. The addition products of vinylacetylene with hydrogen chloride and hydrogen bromide are of considerable interest. With hydrogen chloride an allenic compound is first formed by terminal addition, but this in the presence of cuprous chloride undergoes isomerization (1:3-change) so readily to 2-chlorobutadiene that the latter substance always constitutes part of the reaction product.



Certain salts reinforce the catalytic action of hydrogen chloride, and when cuprous chloride is present none of the

allene derivative survives. 2-Chlorobutadiene formed in this way polymerizes readily, and is used under the name of 'chloroprene' for the synthesis of the artificial rubber known as Duprene or Neoprene.

Hydrogen bromide reacts with vinylacetylene in closely analogous fashion to give first bromomethyl-allene and then 2-bromobutadiene ('bromoprene'). In the case of other alkenyl-acetylenes which have been examined, the hydrogen component of the addendum attaches itself to the terminal acetylenic carbon atom, whilst the halide component becomes linked at the fourth or the second atom. Organic acids (formic, acetic, chloroacetic, and butyric) add to vinylacetylene to give esters.

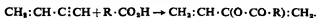

Divinylacetylene reacts with chlorine to form a liquid dichloride, a liquid tetrachloride and a crystalline hexachloride. These three products are formed in succession by 1:4-addition and have the formulae

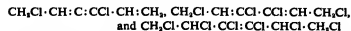

respectively. With thiocresol it yields an addition product, the direction of addition being similar to that shown in the reaction between styrene and thiophenol.

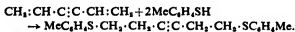

Substitution Reactions. Owing to the presence of a reactive (acetylenic) hydrogen atom vinylacetylene is a prolific source of new and interesting compounds.

(1) With bromine, iodine, or chlorine it yields monohalogen derivatives of the type $\text{CH}_2:\text{CH}:\text{C}:\text{CX}$ ($\text{X} = \text{halogen}$).

(2) With sodium or sodamide it yields sodium vinylacetylide, which, if generated in the presence of a ketone, gives rise to vinyl ethynyl carbinols of the general formula $\text{CH}_2:\text{CH}:\text{C}:\text{C}:\text{RR}'\text{OH}$. The sodium vinylacetylides react energetically with alkylhalides to give alkyl derivatives of the general formula $\text{CH}_2:\text{CH}:\text{C}:\text{C}:\text{R}$.

(3) With potassium mercuri-iodide or with mercuric acetate it gives di-vinylethynyl mercury, $\text{Hg}(\text{C}:\text{C}:\text{CH}:\text{CH}_2)_2$.

(4) With alcohols in the presence of sodium alkoxide at 100° it gives ethers of the type $\text{CH}_2:\text{C}:\text{C}:\text{CH}_2 \cdot \text{OR}$. Here addition doubtless proceeds terminally, and is followed, in the presence of the catalyst, by an allene \rightarrow acetylene rearrangement.

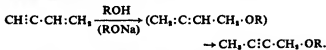

(5) With ethylmagnesium bromide it reacts to give vinyl-ethynyl bromide, $\text{CH}_2:\text{CH}:\text{C}:\text{C}:\text{MgBr}$, which reacts with a variety of reagents in the normal manner.

(6) Both vinylacetylene and diacetylene polymerize readily (see p. 965).

V. POLYMERIZATION

The Nature of Polymerization.

The term polymerization, used in a strict sense, applies only to those processes of molecular aggregation in which the final or polymerized product can be represented as built up of the simple or monomeric molecules only: thus $(M)_x$ is the polymeride of an unsaturated molecule M , where x is a definite, although possibly large and inaccurately determinable number. The tendency of un-

saturated molecules to attain a higher degree of saturation is, however, not confined to those of the same species, and heteropolymerization processes which involve two or more different compounds have been observed. Polymerization in the broader sense is thus a variety of addition reaction in which all the reactant molecules are unsaturated. The term has, however, been used recently in respect of condensation reactions in which molecular complexity is increased by the linking up of molecules with rejection of water, alcohol, or some such substance. Such processes, however, have little in common with true polymerization.

Polymerizing Agents. Many olefines polymerize spontaneously on standing; others polymerize appreciably only when subjected to the action of heat, pressure, ultra-violet light, silent electric discharge, or combinations of these, or when brought together under suitable conditions in the presence of chemical promoting-agents, many of which act catalytically. The list of chemical reagents and contact materials is very large and includes such substances and materials as sulphuric acid, phosphoric acid, iodine, the chlorides of metals and of non-metals (especially aluminium, stannic, boron, and antimony chlorides), silica gel, silicates, alumina, charcoal, alkali metals, other finely divided metals, oxides of metals, organic and inorganic peroxides, organo-metallic compounds, and ozonides. These substances facilitate reaction at, or the 'opening-up' of, double bonds.

Polymerizability. The ease of polymerization of an olefine or diolefine appears to be determined largely by its constitution; for example, unsubstituted substitution by pairs of alkyl groups or by aryl radicals at the ethylenic carbon atoms of an olefinic system appears to enhance the polymerizing capacity, and likewise, substitution at one or both of the inner carbon atoms of a conjugated butadiene appears also to promote polymerizability. The experimental conditions, however, influence polymerization, and in many cases effectively control the course of reaction. Of the external factors which affect polymerization, the temperature and the concentration of the catalyst employed appear to be the most important; increase in pressure accelerates polymerization, but high pressures (above 2,000 atm.) are usually necessary to achieve any considerable effect. The action of different catalysts varies considerably: some (e.g. peroxidic substances) appear to be generally efficacious in promoting polymerization, and others specific in their action. Certain other substances (e.g. sulphur, antimony, phenols, and copper compounds) are of definitely inhibitory (anticatalytic) character.

The Hypothesis of Step-by-step Addition.

Recent evidence goes to show that the polymeric process involves the establishment of normal chemical valencies between the reacting molecules: that is to say, it is not dependent on molecular associations of more or less indefinite character in which the component units are held together by residual affinity. In the simplest case of olefinic polymerization, that of ethylene, the constitution of the dimeric and trimeric [67, 1929], which are obtained by the action of an electric discharge on the gas, is such that aggregation may be represented as proceeding by successive additions, thus:

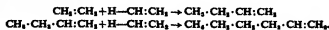

Here the addendum molecule at each additive stage functions as a molecule HX whose components can add at the

ends of the double bond of the other reactant molecule just as do the components of HCl, HBr, &c., in ordinary olefinic additions. If this process is envisaged as extending uniformly and indefinitely, then the product formed at any stage of the aggregation must clearly be a mono-olefine, since at each additive stage the double bond of the addendee molecule disappears, leaving only the unsaturated linkage contained in the addendum. This step-by-step additive mechanism which satisfactorily accounts for the production of the lower polymerides of ethylene has been considered to represent the essential mechanism of olefinic polymerization.

There is abundant evidence to show that at any rate the lower polymeric stages of a considerable number of different olefines all contain only one double bond in the molecule. This is well attested by figures for halogen addition and hydrogenation. In passing, however, from the lower to the higher polymerides, the determination of the degree of unsaturation by halogenation and hydrogenation becomes increasingly difficult and uncertain, and halogenation in particular may be complicated by the occurrence of a considerable measure of substitution side by side with addition. There is not lacking evidence that this method of aggregation by successive discrete additions does not apply generally in the production of polymerides, especially of those of very high molecular weight; this evidence will be referred to later, but for the present it is necessary to examine further the theoretical consequences of the step-by-step addition hypothesis and the correspondence of these with ascertained facts.

Homogeneous and Heterogeneous Modes of Aggregation. Polymerization which is dependent on the capacity of hydrogen to separate from the addendum molecule (at an early or late stage) in the successive addition processes can be expected to proceed in one or more of the following ways:

- (1) In a perfectly regular manner by the addition of a monomeric molecule to another monomeric molecule and then successively to the dimeric, trimeric, tetrameric, &c., which are in turn produced, so that the addendum is always a monomeric molecule.
- (2) In a non-uniform manner proceeding not only by addition of monomer to monomer, dimer, trimer, &c., but also by additions in which any two molecular species which have been produced can participate.
- (3) By additions in which any particular reactant molecule may act either as the addendum or the addendee molecule.
- (4) By additions in which hydrogen (or possibly even radicals in place of hydrogen) may separate from either of the ethylenic carbons of the addendum molecule.

Many polymerides such as polystyrene undoubtedly possess an essentially regular constitution and are built up by a mechanism which links the constituent units together end to end. If these polymerides are formed by step-wise addition, they will have the general framework

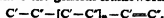

that is to say, they will be definitely mono-olefinic; but such chain-structures could arise only so long as the addendum is always a monomeric molecule, and so long as the hydrogen atom always separates from the same ethylenic carbon atom of the addendum. In any given polymerization product formed in this restricted way the only hetero-

geneity of composition will be that due to variation in the value of n . As soon, however, as variation of the addition process in one of the ways indicated in (2), (3), and (4) above becomes possible, then the number of isomerides theoretically possible, even in the lower stages of aggregation, becomes very large and the chain in becoming lengthened becomes also branched.

Structure of Dimerides and Trimerides. Recent work has shown that the dimerides of a number of simple olefines are analogous in constitution to that of ethylene, and their formation can be represented as due to the addition of one molecule (with separation of hydrogen) to the double bond of the other. In this group belong *isobutene* [63, 1930-1], *o*-diphenylethylene [8, 1930], α -methylstyrene [7, 1931], and indene [95, 1928, 1931, 1932].

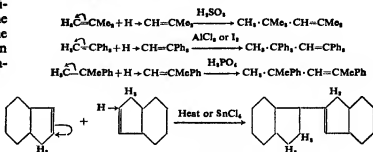

In formulating the probable course of any such addition it is necessary to take into account the direction of dominant polarization at the double bond of the addendee molecule and the position from which hydrogen is most likely to separate, having regard to the constitution and polarizability of the addendum molecule. According to current conceptions the direction of polarization will be determined principally by the nature of the groups substituting the ethylenic skeleton (see p. 945). Hence in an unsymmetrically substituted molecule such as that of *isobutene* or *o*-diphenylethylene the dominant polarization which governs the direction of addition to the addendee molecule may not promote the separation of hydrogen from the addendum molecule, and presumably the occurrence of polymerization at all depends on the facility with which the reverse polarization ($H \rightarrow CH=CM_2$) can also take place. For a monosubstituted olefine, however, the formation of 4 different dimerides might be anticipated in accordance with the general possibility of opposite polarizations occurring in each of the reacting molecules; usually only one or two of these would be likely to arise in significant quantity.

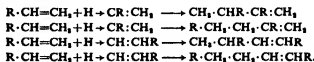

Actually, in the case of *isobutene* a second dimeride, $CH_3 \cdot CMe_2 \cdot CH_2 \cdot CMe_2 \cdot CH_3$, accompanies the first in the ratio of 4:1, and differs from it only in the position of the double bond. The formation of this compound might perhaps be tentatively regarded as due to secondary change promoted by the experimental conditions of polymerization, but it might, on the other hand, be a necessary consequence of the additive mechanism governing dimerization. Secondary changes do occur, as is seen in the example of *o*-diphenylethylene and α -methylstyrene, where ring-closure occurs avoidably or unavoidably according to the polymerizing agent used; in these cases, however, the secondary change is of an obvious and predictable nature.

These authors prefer to regard the amylene molecule $\text{CMe}_2\text{:CHMe}$ as capable of activation in the manner $\text{CH}_3^+\text{CMe:CHMe}$, the positive and negative signs being used merely to indicate the relative electrochemical character, that is to say, the relative affinities of the adjacent carbon atoms for the bonding pair of electrons, and not to indicate the occurrence of ionization. They justify the hypothesis of the incipient separation of methyl rather than of hydrogen, on the grounds of the greater strength of the C—H bond than of the C—C bond. They do not preclude, however, polarization with incipient separation of H as shown in (f) below. The formation of the two observed diamylenes thus follows by addition of the polarized addendum to the olefines derivable by dehydration of the carbinol:

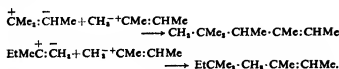

Similarly, the formation of *diisobutylene* is formulated in the manner:

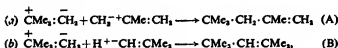

and of *trisisobutene* (the formation of which involves that particular dimeride which constitutes 80% of *diisobutene*) in the manner:

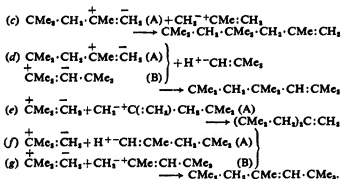

The determination of the factors which govern the ease and degree of polymerization of olefines in the presence of sulphuric acid is complicated by the occurrence of two additive reactions which commonly compete with polymerization. These involve the formation of alcohols and of mono- and di-alkyl esters of sulphuric acid, and both reactions appear to be independent of one another and of the polymerization process. So far as observations show, the relative importance of the three types of addition in a given case is determined by the constitution and molecular weight of the olefine, by the concentration of the acid, and the duration of reaction [12, 1918]. Relatively small amounts of sulphuric acid are effective in promoting polymerization.

As regards the effect of constitution, substituted ethylenes and the higher olefines in general undergo polymerization more readily than ethylene itself, but there is great diversity in the ease of reaction of differently substituted compounds [71, 1927]. In the amylene series, for example, trimethylethylene (IV) and *as*-methyl ethylene (III) at room temperature dissolve in an equimolecular quantity of 61%

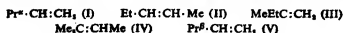

sulphuric acid in approximately one-twentieth of the time required for the solution of Δ^1 - or Δ^2 -pentene (I, II). This strength of acid does not affect *isopropylethylene* (V), nor does it bring about polymerization of the two straight-chained amylene; but it slowly converts the two more reactive amylene into dimerides. Such reactions as these, however, are very susceptible to changes of temperature. It is a striking fact that the two amylene (III and IV) in which one of the ethylenic carbon atoms is dialkylated react much more rapidly with sulphuric acid than do their isomerides (I) and (II), and that the influence of the propyl group differs markedly from the *isopropyl* group. *Isopropyl ethylene* appears to be affected only by acid of such superior strength that polymerization takes place at once with the formation of higher polymerides than the dimeride and to the exclusion of alcohol formation. The work of Brooks and Humphrey [54, 1913] indicates that with rise of molecular weight the tendency of olefines is towards polymerization rather than alcohol- or ester-formation.

Polymerization by Heat.

The effect of heat on olefines depends on the temperature employed, the constitution of the hydrocarbon, and on the experimental conditions of reaction. Investigation of the heats of reaction of various polymerization processes which olefines undergo reveals the latter to be exothermic; accordingly, low temperatures may be expected to favour polymerization, and the higher temperatures depolymerization. Since, however, reaction velocity is usually lower at the lower temperatures, catalysts may be needed for the promotion of low-temperature polymerization. From a calculation of the free energies Francis and Kleinschmidt [31, 1928] have concluded that olefines tend to polymerize below about 425°, whilst above this temperature pyrolytic degradation or 'cracking' (see p. 946) takes place. In the case of gaseous olefines increased pressure favours polymerization: ethylene and propene both undergo an 80–87% conversion into non-aromatic liquids by heating at 380° to 400° for 2½ to 3 hours under maximum pressures of 67–94 atm. [24, 1932].

Hypotheses of Macropolymerization.

Many olefinic substances resemble formaldehyde in forming polymerides of very high molecular weight. Amongst these may be mentioned styrene (vinyl naphthalene) a number of vinyl ethers and esters, and various of their substitution products. Styrene, PhCH:CH_2 , forms a series of polymerides, the higher ones of which attain a molecular weight of over 100,000 (i.e. 1,000 monomeric units). There are other olefinic substances, however, such as indene and allyl chloride, which give polymerides intermediate in average molecular magnitude between the polystyrenes and the earliest polymeric stages: the polyindenes range from M_2 to M_{14} (M = the monomeric unit), and the polyallyl chlorides from M_2 to M_{14} .

Staudinger's Hypothesis. According to Staudinger [84, 1928–9] the polymerization of styrene proceeds with the formation of long thread-like molecules (macromolecules) built up according to the following general plan:

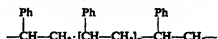

By employing a variety of experimental conditions, polymerides of all grades of molecular magnitude have been obtained, the different individual polymerides consisting of

'polymer-homologues' which may be fractionated into groups of approximately the same molecular size by use of suitable solvents. The polystyrenes of molecular weight 100,000 are still readily soluble: their molecules, some of which consist of chains which are 1,000 times longer than broad, are colloidal in one dimension only, and their stability decreases as the length becomes extreme. On heating they undergo 'cracking' with formation of lower homologues.

Staudinger's unbranched formula for the polystyrenes differs essentially from that which would apply if the polymeric molecules were built up by a process of step-wise addition, i.e. via the dimeric, trimeric, tetrameric, &c. The double bonds of the monomeric units presumably 'open out', and the units themselves become linked head to tail to form the macromolecules depicted in Staudinger's formula. There can be no element of unsaturation in the chains except that represented by the free valencies at the ends, supposing these survive. It seems probable that in most of the polymeric molecules the free valencies rearrange (with inter- or intra-molecular hydrogen migration) to form a double bond, but Staudinger in his earlier papers suggested that the polymerides of low molecular weight are ring structures formed by interaction of the terminal free valencies, and that the higher members also probably exist in the form of long narrow rings whose sides are close together and parallel:

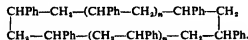

Forms such as these latter would possess wholly saturated chains.

The Constitution of the Polyindenes: Growth and Degradation of Chains. The polymerization of indene by heat or by the action of catalysts such as stannic chloride or antimony pentachloride results in the formation of an unbroken series of compounds representing indene in different stages of molecular complexity. In Staudinger's view the polyindenes are built up in the same way as the polystyrenes, and probably pairs of the polymeric chains become linked up at one or both ends to form either doubled chains (with free ends) or rings [83, 1929]. From an examination of the polyindenes, however, Whitby and Katz [94, 1931] conclude that the polyindenes are open-chain compounds formed by step-wise addition with hydrogen separation, the substances having the general formula:

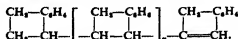

The conclusion rests largely on the fact that samples of polyindene ranging in molecular weight from 414 (trimeric) to 3,320 (29 units) were found to be alike in their capacity to absorb 2 atoms of bromine per molecule. The following important points concerning the behaviour of polymerized indene have been established:

- (1) Polyindene subjected to slow pyrolytic distillation at temperatures rising to 400° under 2 mm. pressure gives yields as high as 80% of a distillate containing indene, di-indene, and tri-indene. The residue, undistillable at 400°, contains polyindenes of greater molecular weight than the trimeride, but not so high as the original material. Both the distillable and the residual (undistillable) low polymerides are definitely derived by the cracking of high polymerides.

- (2) Cracking takes place the more readily the higher the molecular weight of the sample taken.
- (3) Thermo-polymerized indene, although apparently more markedly heterogeneous than polyindene of approximately the same mean molecular weight prepared by means of stannic chloride, behaves on pyrolysis very similarly to the latter.
- (4) Di-indene at ordinary pressure yields on distillation 74% of indene.
- (5) Di-indene can be polymerized by the same agencies which effect the polymerization of indene (e.g. sulphuric acid, antimony pentachloride, or heat) although with less readiness.
- (6) A mixture of mono- and di-indene yields tri-indene when heated.
- (7) In the thermo-polymerization of mono- and of di-indene the molecular weight of the polymeric product rises as the percentage of material which has undergone polymerization increases; also the molecular weight attained when polymerization is complete, or nearly so, is lower the higher the temperature applied.

The results of Whitby and Katz indicate that polymeric chains when once formed can grow larger. They also indicate that the cracking of the high polymerides does not proceed by a regular division and subdivision of the long-chain molecules, but involves at an early stage the scission of monomeric indene from the ends of the molecules; subsequently, as the temperature is raised, the scission of di-indene occurs, and still later the scission of the chain at several points simultaneously sets in, as is indicated in the following scheme in which M represents a monomeric unit:

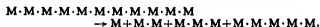

According to Houtz and Adkins [38, 1933] two distinct processes are involved in the formation of polymerides of the long-chain type: the one is the initiation of reaction or the starting of chains, the other is the increase in the length of chain. That many substances can catalyse the initiation of chains is a matter of common observation, but there is little available information as to the efficacy or otherwise of catalysts in promoting the lengthening of chains. Experiments, however, on the polymerization of styrene by ozonides show that if only a little catalyst is present the chains become very long, even at a temperature as high as 100° C.; but if many chains have been begun in the presence of an active catalyst, then all the available styrene is used up before any of the chains become very long. The polymerization of styrene therefore is not a process that must of necessity proceed to completion without interruption: on the contrary, the lengthening of the carbon chain may be stopped by precipitating and drying the polystyrene and afterwards continued when styrene is made available.

In connexion with the mechanism of chain-growth, observations of Lebedev and Kobliansky [56, 1930] on the thermal polymerization of *isobutene* are of interest. These authors state that when *isobutene* is heated in a glass tube at 200° it yields only *trisobutene*, but if polymerized by contact with active silicate (floridin) it yields polymerides ranging from di- to hepta-merides together with higher polymerides which suffer depolymerization on attempted distillation. Although prolongation of the period of contact of hydrocarbon and catalyst leads to an increase in the proportion of the more highly polymerized forms, not all the individual polymerides seem to suffer further

polymerization. The changes which take place are considered to be the following:

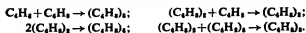

All these polymerizations can be reversed by heating the substances at 200° C. in contact with the catalyst, but in all cases some monomeric isobutene is formed, and dimeric isobutene is the most stable variety. Thus Lebedev and Kobiliansky hold the view that dimeric and trimeric isobutene (for example) can unite to give a higher polymeride with general properties akin to those of polystyrene and polyindene without first being degraded to the monomeric form.

Mechanism of Chain-polymerization. The processes resulting in the formation of long-chain polymerides of the type of styrene display the essential characteristics of a chain-reaction mechanism. It is necessary to postulate that activated molecules (arising owing to thermal motion, catalytic action, or to the absorption of light) appear in the polymerizing substance, and these combine with the monomeric form to give double molecules which become activated at the expense of the energy liberated during this combination process, thereby forming, for instance, a free valency at the end. The active chain interacts with another monomeric molecule with the formation of a triple molecule, the activation of the latter being again due to the energy liberated during this interaction. This additive process goes on until, for one reason or another, the active end of the polymeride becomes deactivated. Usually, therefore, the length of the polymeride, i.e. the number of molecules in it, will correspond to the length of the reaction chain. The polymerization may be greatly accelerated by traces of certain foreign substances (e.g. peroxides), or may be brought to a standstill by others [81].

From a theoretical consideration of the velocities of reaction in polymerizations which proceed by step-wise additions Chalmers [16, 1934] has calculated, on the fundamental assumption that the rates of the consecutive reactions are not greater than that of the dimerization, that the chief polymerides produced will be the lower ones and that the proportions of these will rapidly fall off with increasing complexity, so that less than 0.5% will exceed decameric magnitude. True macropolymerizations do not give results in agreement with this conclusion: indeed, styrene, vinyl acetate, the acrylic esters, &c., give polymeric mixtures of which the complexity is so much higher than the limit fixed by the step-wise theory that this latter can no longer be entertained. A few polymerizations, such as those of olefines by sulphuric acid, doubtless take place by an abbreviated series of step-wise reactions, and these confirm the above deduction since, besides a predominant quantity of dimeride and trimeride, only inconsiderable amounts of tetrameride and higher polymerides are formed.

The small proportions of the earlier members in the various polymeric products from substances such as styrene shows that the velocity of addition of monomeride to the transitory dimeride, trimeride, &c., must be very much greater than that of the initiative coupling of monomeric molecules. This absence of appreciable proportions of the lower polymerides has been observed at the beginning of and during macropolymerizations in such cases as have been investigated. Chalmers considers that macropolymerization proceeds as a chain-reaction, and suggests that in those reactions in which the average order of polymerization n remains unaltered throughout their course (i.e. each

successive chain initiated rapidly attains the order of complexity n) the following mechanism probably holds:

(I) $M \rightarrow M$ (activated)—comparatively slow.

(II) M (activated) + $(n-1)M \rightarrow M_n$ —practically instantaneous.

Only a reaction scheme in which the carbon atoms bound by the double bond alone take part can be brought into accord with the almost instantaneous velocity of concatenation, and Chalmers is inclined to accept Staudinger's early proposal that each of the polymers has free terminal bonds (or trivalent carbons) so that no wandering of hydrogen is involved. Accordingly, for a simple olefine, we have:

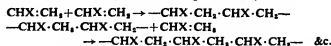

In catalytic processes it is suggested that the activated ('trigger') molecule is formed by the union of the catalyst with only one unsaturated atom of the monomeride, giving a half-addition product with a free bond.

Diolefines

The two most important groups of diene hydrocarbons, viz. the conjugated butadienes and the alkenes, are alike in the tendency of their members to undergo polymerization. The butadienoid hydrocarbons polymerize with especial facility and, owing to their tendency to give rubber-like polymerides of high molecular weight, their behaviour has been investigated by many workers.

Dimerides of Conjugated Diolefines.

Straight-chained Dimerides. Two naturally occurring dimerides of conjugated diolefines are known. These are ocimene [27, 1900, 1907, 1908, 1916, 1926], obtained from the leaves of a variety of *Ocimum basilicum*, and myrcene, contained in oil of bay [74, 1895, 1924]:

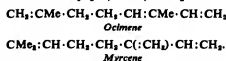

No single straight-chained dimeride of a butadiene is at present known to be formed artificially, although formerly a hydrocarbon, β -myrcene (supposedly



[72, 1914-15], was reputed to be present in the heat-degradation product of natural rubber.

Cyclic Dimerides. The common mode of artificial dimeride-formation superficially resembles that of the formation of addition products between conjugated butadienes and maleic anhydride (p. 950). All the dimerides whose constitutions have been determined, with the exception of that from α -phenylbutadiene [6, 1935], are held to be derivatives of cyclohexene, and this applies whether the hydrocarbons are open-chain or cyclic butadienes. If the reaction were to proceed always by the addition of an ethylenic unit of one molecule to the terminals of a second molecule of the diene, thus:

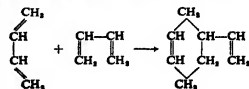

it follows that a hydrocarbon $CRR^1:CR^2:CR^3R^4$, in which $R, R^1, R^2, \&c.$, represent hydrogen, alkyl, aryl, &c., could yield from 1 to 4 isomeric substituted cyclohexenes (e.g. *cis*-dimethylbutadiene might be expected to yield some or all of the four forms shown below.)

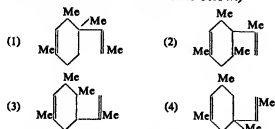

But in the dimerization process both reacting molecules are 'anionoid' (electron-donating, cf. p. 945) in character, whereas in the Diels-Alder reaction one is 'kationoid' (electron-accepting) and one 'anionoid'. Consequently the course of reaction in dimerization processes is with little doubt quite distinct from that in the Diels-Alder addition, and probably involves first the formation of an open-chain dimeric form (kation) which subsequently cyclizes to give one or more (usually cyclohexenic) dimers.

Dimerides of the dienes listed in the following table are known, but although in these examples the general struc-

ture of the compounds has been established, only in one or two cases has the constitution of the isomeric forms been fully verified.

Dimerides of Cyclic Dienes. The dimerization of cyclopentadiene proceeds spontaneously to give a product strictly analogous to the foregoing forms, that is to say, to give a derivative of cyclohexene [1, 1931].

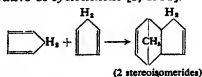

Dimerization of cyclohexadiene also follows a similar course when the hydrocarbon is heated [2, 1932-3]:

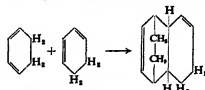

Trimerides and Tetramerides of Cyclic Dienes. In only one example, that of cyclopentadiene, has the constitution of a trimeric form been directly determined. Tricyclopentadiene is formed by the addition of monomeric struc-

Hydrocarbon	Formula	Dimerides reported	Number possible	Reference
Butadiene	$CH_2:CH:CH:CH_2$		1	1, 2
Piperylene	$CHMe:CH:CH:CH_2$		4	3
Isoprene	$CH_2:CMe:CH:CH_2$		4	2, 4
2:3-Dimethyl-butadiene	$CH_2:CMe:CMe:CH_2$		1	5, 6
1:2-Dimethyl-butadiene	$CHMe:CMe:CH:CH_2$	Two 	4	6
1-Phenyl-butadiene	$CHPh:CH:CH:CH_2$		4	2
1:1:4:4-Tetramethyl-butadiene	$CMc_2:CH:CH:CMc_2$		1	2
1:1:2:3:4-Tetramethyl-butadiene	$CHMe:CMe:CMe:CHMe$		1	7

1. Lebedev, S. V., *J. Russ. Phys. Chem. Soc.* **42**, 949 (1910); **43**, 1124 (1911); **45**, 1296 (1913).

2. Lebedev, S. V., and Ivanov, V. N., *ibid.* **46**, 997 (1916).

3. Lebedev, S. V., and Mereshkovskii, B. K., *ibid.* **45**, 1249 (1913).

4. Wallach, O., *Annalen*, **227**, 277 (1885); Lebedev, S. V., *J. Russ. Phys. Chem. Soc.* **42**, 949 (1910); **45**, 1249, 1296 (1913); *J.S.C.I.* **33**, 1224 (1914); Wagner-Jauregg, *Annalen*, **488**, 176 (1931).

5. Lebedev, S. V., *J. Russ. Phys. Chem. Soc.* **42**, 949 (1910); *Zentr.* **1**, 1002 (1918).

6. Whitby, G. S., and Galloway, W., *Canadian J. Res.* **6**, 280 (1932).

7. Van Romburgh, *Proc. K. Akad. Wetensch. Amsterdam*, **34**, 224 (1931).

cyclopentadiene to *dicyclopentadiene* at the double bond in the bridged *cyclohexene* ring of the latter [3, 1932].

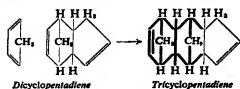

Two forms of the trimeride are obtained, and since the spatial configuration of that portion of the carbon skeleton represented by thick lines in the formula has been shown to be exactly the same for each form, the isomerism is to be attributed to the alternative spatial arrangements that can be assumed by the *cyclopentene* ring with respect to the plane of the adjoining ring. It is probable, indeed, that the two forms of the trimeride arise by addition to the two known forms of the dimeride respectively.

With regard to the constitution of tetramerides, indications are afforded by the course followed in the formation of 'mixed' addition products, e.g. (A) and (B), that the more reactive bond in any cyclic butadiene dimeride or

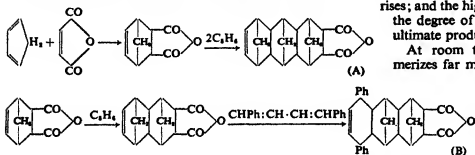

trimeride is commonly the one in the bridged *cyclohexene* ring, consequently the higher polymerides are probably formed by the successive addition of monomeric molecules to the *cyclohexenic* double bond.

Course of Butadiene Polymerization.

The open-chain conjugated dienes yield in general two types of polymerized products, viz. (1) oily cyclic dimerides as noted above, and (2) caoutchouc-like polymerides which are heterogeneous in molecular magnitude and probably also not strictly uniform in their manner of building up. The cyclic dimerides, although frequently further polymerizable, are not further polymerizable to caoutchoucs and are not intermediates in the passage of dienes into caoutchoucs; moreover, their formation has, so far as is known, no special significance in relation to the mechanism of the high-polymerization process by which caoutchoucs are formed. Thus polymerization amongst conjugated dienes is not of homogeneous character, and can proceed by more than one route.

A few trimerides of open-chain dienes have, however, been obtained. Wagner-Jauregg [88, 1932] has found that isoprene yields by the action of acetic acid containing a little concentrated sulphuric acid a small proportion of a monocyclic C_{12} -hydrocarbon containing three double bonds, and also a mixture of sesquiterpene alcohols and alcohols containing the di-isoprene skeleton; the C_{12} -hydrocarbon is convertible by formic acid into a dicyclic sesquiterpene of the caryophyllene group. It has also been observed that the polymeride obtained by the action of stannic chloride on isoprene yields 1:2:5-trimethyl-naph-

thalene on dehydrogenation with selenium. Furthermore, 2:3-dimethylbutadiene yields a trimeride (in addition to higher products) when treated with acetic acid-sulphuric acid [28]. This latter trimeride, formed in 33% yield, is of sesquiterpene type, and probably contains a hydronaphthalene skeleton. It is not yet clear how these trimerides are built up, but it is certain that they are not intermediates in the production of such long-chain polymerides as rubber, or apparently of any other high polymerides.

Polymerization by Heat. Experiments by Whitby and Crozier [91, 1932] on the polymerizing effect of heat upon isoprene and 3:4-dimethylbutadiene at temperatures between 10° and 145° show that the molecular weight of the rubber produced increases as the percentage of the diene which has undergone polymerization rises. Further, the higher the temperature applied to produce polymerization, the lower is the molecular weight of the rubber produced after similar amounts have been formed; also, as polymerization at a given temperature progresses, the viscosity of sols of the product rises. Thus it appears that as polymerization by heat progresses at a given temperature, the degree of polymerization (20-molecular, 25-molecular, &c.) rises; and the higher the temperature applied, the lower is the degree of polymerization which is attainable in the ultimate product.

At room temperature 3:4-dimethylbutadiene polymerizes far more readily than isoprene, but the rate of polymerization of isoprene when heated is greater than that of dimethylbutadiene. Again, heat-polymerization leads to the formation of a much larger proportion of oily products in the case of isoprene than in that of dimethylbutadiene. Increase of the temperature

applied raises the proportion of oil to caoutchouc in both cases.

The polymeric products in dimethylbutadiene-caoutchouc, like those contained in polyolefines, consist of a mixture of polymerides of different degrees of molecular complexity. Whitby and Crozier find that dimethylbutadiene-caoutchouc contains one double bond for each unit of the diene which has gone to form the polymeride. Solutions of the caoutchoucs obtained by the heat-polymerization of both isoprene and dimethylbutadiene suffer decrease of viscosity on keeping, owing to oxidation. This tendency can be checked by the addition of an antioxidant, such as dimethylaniline.

Polymerization by Metal Halides. The chlorides of antimony, tin, and aluminium, and to a lesser degree the halides of iron, thorium, and boron, and other halogen compounds, effect the polymerization of isoprene and dimethylbutadiene in the cold. The polymerides in all observed cases are white or pale-coloured substances, inelastic and quite unlike rubber; they resemble the products obtained by the action of halides on natural rubber.

Influence of Constitution on Polymerizing Capacity.

Although, as mentioned above, in the examples of isoprene and 3:4-dimethylbutadiene, the conditions of reaction can materially affect the relative ease of polymerization of different conjugated dienes, yet the most notable influence on polymerization is that of the substituent groups in the butadiene system. This influence is apparent from the unequal tendencies of differently substituted dienes to polymerize when kept at room temperature out of contact with air [92, 1927, 1932].

Lebedev [57, 1913] found that piperylene polymerizes less readily than isoprene, their respective degrees of polymerization when heated at 150° for 15 hours being 30 and 79%. Whitby and Gallay [93, 1932] report that the presence of an unsubstituted terminal methylene group is favourable to the occurrence of polymerization; also, in general, increase in the number of substituent groups reduces the ease of polymerization, especially to products of high molecular weight. The quantitative results of these latter authors for the heat-polymerizability of five open-chain dimethylbutadienes and two trimethylbutadienes are given in the table below.

Polymerization of Dimethyl- $\Delta^{1,3}$ -butadienes by Heat

	Hydrocarbon (position of methyl groups)				
	2:3	1:2	1:1*	1:3	1:4
(A) 30 days at 100°					
Dimeride formed (%)	54	53	43	32	20
Higher polymeride (%)	46	38	14	19	32 (sic)
Total polymerization (%)	100	91	57	51	33
Mol. wt. of higher polymeride	1,377	919	432	1,334	795
(B) 30 days at 150°					
Dimeride formed (%)	63	73	59	59	51
Higher polymeride (%)	37	27	24	19	17
Total polymerization (%)	100	100	83	78	68
Mol. wt. of higher polymeride	1,184	674	304	1,002	602

* The preparation obtained in the way described by Whitby and Gallay would not contain more than a small proportion of the 1:1-compound [28].

Polymerization of Trimethyl- $\Delta^{1,3}$ -butadienes by Heat

	Hydrocarbon (position of methyl groups)			
	1:1:3		1:1:4	
	13.5 days at 85°	30 days at 85° or 38 days at 140°	13.5 days at 85°	38 days at 140°
Dimeride formed (%)	1	35	0	20
Higher polymeride (%)	9	28	trace	4
Total polymerization (%)	10	63	..	24
Mol. wt. of higher polymeride	..	374

The differences in the relative polymerizing capacities of individual hydrocarbons as indicated by the results of Whitby and Gallay, and of other workers, might be expected from considerations of the dependence of polarizability on structure. Unsubstituted butadiene contains two mono-substituted (i.e. vinyl-substituted) and therefore 'unbalanced' ethylenic units, $\text{CH}_2\text{:CHR}$ ($\text{R} = \text{vinyl}$), each with an inherently strong tendency to polarization. If a methyl group be now introduced into the diene as a substituent, three types of ethylenic unit are produced, viz. (1) $\text{CH}_2\text{:CMeR}$, (2) CHMe:CHR , and (3) $\text{CH}_2\text{:CH-R}$ ($\text{R}' = \text{propenyl}$, i.e. CHMe:CH- or $\text{CH}_2\text{:CMe-}$), of which the most unbalanced, and presumably the most likely to undergo effective polarization, is (1), and the least unbalanced and least effectively polarized is (2). 2:3-Dimethylbutadiene thus contains a pair of unbalanced and highly polymerizable units which might be expected to bring about a strong tendency to polymerize, but as these units would normally polarize in opposite directions, they might well promote 1:2-attachment of the diene molecules as represented in (A) rather than 1:4-attachment as shown in (B).

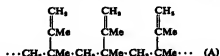

Of the other dimethylbutadienes, composed of combinations of unbalanced (mono- or tri-substituted) and balanced (di-substituted) olefinic units, the 1:4-compound would be expected to show the least tendency towards polymerization and the 1:2- and (veritable) 1:1-compounds the greatest; furthermore, the tendency towards terminal polymerization might perhaps be expected to be stronger in the 1:1- and 1:3-compounds than in the 1:2- or 1:4-compounds.

Long-chain Polymerization.

Certain of the butadienoid hydrocarbons (e.g. 3:4-dimethylbutadiene) show a strong tendency to yield more or less rubber-like masses of high molecular weight either on standing or on treatment with sodium or other catalysts. The production of 'sodium rubber' from isoprene and of 'methyl rubber' from 3:4-dimethylbutadiene is well known. A considerable amount of light is thrown on the course of such polymerizations by observations of Carothers and his collaborators with chloroprene and bromoprene [15, 1931, 1933].

Chloroprene Polymerides. Polymerization of chloroprene leads to the formation of several distinctive types of polymeride as shown in the scheme:



Granular (ω) Polymeride Non-plastic (μ) Polymeride

The influence of various conditions in determining the incidence of these types is indicated in the following table.

Influence of Conditions on the Polymerization of Chloroprene

Condition	Monoprene to β -polymeride	Monoprene to α -polymeride	α -Polyrene to μ -polymeride	Monoprene to ω -polymeride
Temperature	+++	++	+	Autocatalytic, initiated by strong
Pressure	+	+	+	ultra-violet light and by metal surfaces.
Light	0	++	0 (?)	
Oxygen	0	+++	++ (?)	
Autoxidants	0	---	±	

+ Accelerates; 0 no effect; - inhibits.

The β -polymeride, a terpene-like material, is an undesirable by-product in rubber synthesis. Its formation becomes appreciable only at temperatures higher than are necessary to bring about a rapid formation of α -polyrene. In this connexion it is to be noted that butadiene, isoprene, and dimethylbutadiene polymerize comparatively very slowly: to get the transformation to proceed at a reasonable rate, elevated temperatures are generally used, and this results in the formation of relatively large amounts of this β -type of polymeride.

The α -polymeride, corresponding to unvulcanized rubber, is an intermediate step in the formation of the μ -product, which corresponds to vulcanized rubber. For its formation the temperature must not be too high, since elevated temperatures accelerate the transformation of α -polymeride to μ -polymeride more than it accelerates the formation of α -polymeride from monomeride. In addition, the reaction must not be too slow, since most inhibiting influences have a greater decelerating effect on the formation of the α - than on the μ -product; also very slow reaction frequently leads to the formation of the ω -polymeride. Light and pressure both appear to have a greater accelerating effect on the formation of the α -polyrene than on the transformation of this into the μ -polyrene.

The ω -polychloroprene, useless as an artificial rubber, is made up of discrete rubber-like particles which are non-plastic and not even swelled by rubber solvents. When a speck of the ω -polymer appears or is introduced in a specimen of incompletely polymerized chloroprene, the entire specimen is soon more or less completely converted into the ω -polymeride. The formation of nuclei of the ω -polymer is favoured by strong ultra-violet light and by metal surfaces (e.g. sodium, potassium, mercury, iron, copper, and aluminium). The opportunities for the formation of such nuclei are also increased by a long reaction time under any particular set of conditions. It is regarded by Carothers as probable that the cauliflower-like masses which have often been obtained from isoprene, butadiene, and dimethylbutadiene correspond to the μ -type of polymeride, and possibly this is the form in which the polymerides of these dienes are usually obtained. The comparatively slow rate of polymerization of these dienes is especially favourable to the formation of the ω -polymeride; moreover, most of the agencies that are available to hasten the slow polymerization of isoprene and butadiene are such as have been found in the case of chloroprene to affect more strongly the conversion of the α - into the μ -polymeride than the formation of the α -polymeride. The isolation of a true α -polymeride from the isoprene and butadiene products may accordingly present special difficulties, although it is on record [20, 1930] that when isoprene is subject to a pressure of 12,000 atm. until 30% of the hydrocarbon has polymerized, the polymeride is at least 90% soluble in ether, but if the reaction is allowed to proceed until 80% of isoprene has polymerized, the polymeride is completely insoluble. Bromoprene behaves analogously to chloroprene, and the difference in the course of polymerization between these halogeno-dienes, on the one hand, and the diene hydrocarbons, on the other, appears to be a difference of degree rather than of kind.

Polymerides of Isoprene and other Dienes. According to Stauffer, the polymerization of isoprene to caoutchouc involves the successive 1:4-addition of isoprene molecules to form long chains:

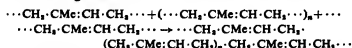

Such a reaction can be conceived as proceeding by a chain mechanism. Whitby [90, 1929, 1932], however, represents the process as proceeding in step-wise fashion by the addition of monomeric isoprene to dimeride, trimeride, &c., with hydrogen separation:

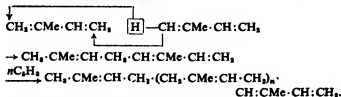

Additions of this latter kind presumably might proceed by 1:2- as well as by 1:4-attachments of molecules; moreover, in the case of an unsymmetrical diene such as isoprene, the particular hydrogen atom which separates from the addendum (whether 1- or 4-) and the point and direction of addition are not matters of indifference in regard to the constitution of the product. Nevertheless, the molecules of natural rubber, sodium rubber (isoprene polymerized by sodium) [65, 1932], and methyl rubber (2:3-dimethylbutadiene polymerized by heat) [34, 1911, 1913] all consist

entirely or in the main of terminally and regularly combined monomeric units. Midgley, however, concludes from the nature of the pyrolysis products and oxidation products of sodium rubber that the double bonds do not occur regularly in the carbon chain as shown below, but that some modification of the skeleton, e.g. by cyclization, probably occurs.

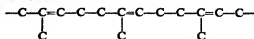

Ziegler has examined the polymerization of conjugated dienes by alkali metals and alkali metal alkyls [105, 1928, 1929, 1934]. In the case of metallic alkyls he explains the process on the assumption that the compound first formed by reaction with the hydrocarbon is an addition product: thus butadiene yields with a metallic alkyl, RK, a compound $\text{CH}_2\text{R} \cdot \text{CHK} \cdot \text{CH} \cdot \text{CH}_2$ (1:2-addition) or $\text{CH}_2\text{R} \cdot \text{CH} \cdot \text{CH} \cdot \text{CH}_2\text{K}$ (1:4-addition). This compound can react with another molecule of hydrocarbon to yield a second addition product, e.g.

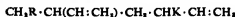

if the addition is of 1:2-type, which also is a metallic compound. The process may then proceed in the same way until stopped by external agency, by process of change in other directions, or by the increasing size of the molecule inducing extreme sluggishness of reaction. The final product has then the constitution (A) or (B):

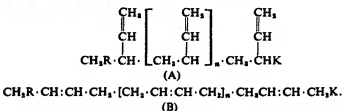

In such a polymerization process the course of reaction will depend on the ratio of the velocity of the first stage of addition to that of the succeeding stages: only if the primary reaction is rapid in relation to the others, or its velocity is of about the same order of magnitude as those of the others, are relatively simple products obtained. In practice butadiene is polymerized by potassium phenylisopropyl up to the decameric stage and by metallic lithium to a resin of high molecular weight; piperylene is polymerized by lithium up to the pentameric stage, and 2:3-dimethylbutadiene by the same metal mainly to the dimeric stage.

Certain highly polymerizable unsaturated compounds such as styrene and butadiene are polymerized by metallic alkyls, which are normally somewhat sluggish in reacting additively with unsaturated hydrocarbons. The reaction then proceeds without the occurrence of any visible interaction between the first metallo-organic product and the hydrocarbon. Here it is supposed that the additive reaction which first occurs takes place only slowly, but the product is much more reactive towards the unsaturated hydrocarbon than is the simple metallic alkyl first taken: consequently the polymerization goes with great speed from the first addition product onwards, as soon as a little of the latter is once formed. Only to an extremely slight extent does the original metallic alkyl serve to build up the high-molecular polymerization product, so that the alkali metal compound has the appearance of acting catalytically and remains substantially unchanged. No evidence has been obtained indicating the formation of radical-like intermediates.

Pressure Polymerization. Isoprene polymerizes when compressed at high pressures (3,000 to 12,000 atm.) at the ordinary temperature. Peroxide catalysis appears to be essential for the process, but only minute traces of the active oxygenated compound are required to initiate it. Conant and Petersen [19, 1932] suggest that the mechanism is a series of chain reactions in the liquid hydrocarbon, initiated by the spontaneous decomposition from time to time of the peroxide. The accelerating effect of great pressures is then due to the orientation of the isoprene molecules into a more compact bundle in which longer reaction chains can be propagated by the spontaneous decomposition of a single peroxide molecule. Presumably as the volume of liquid diminishes by compression a definite orientation of molecules ensues, probably similar to that which exists in the polymeride itself. As each molecule becomes in turn activated by the energy derived from the peroxide, it unites with its neighbour, the product becoming active by virtue of the exothermic nature of the polymerization process. The accelerating effect of temperature is regarded as being due to the more frequent initiation of peroxide decompositions and hence of reaction chains. The efficiency of a given peroxide catalyst probably depends on its instability, and that of a negative catalyst on its power to break reaction chains.

Acetylene and Conjugated Olefine-acetylenes

The case of acetylene-polymerization is somewhat more complicated than that of olefine-polymerization owing to the fact that whereas by addition to olefinic linkages saturated bonds are formed which no longer possess any additive capacity, by addition to acetylenic linkages ethylenic bonds are formed which may reasonably be expected to participate in further additions. As early as the dimeric stage, therefore, mixed olefine acetylene systems must inevitably arise unless (1) aromatic substances can be formed by the simultaneous interaction of three acetylenic molecules (as has frequently been assumed in the representation of the formation of benzene from acetylene at a red heat), (2) homogeneous polymerization of acetylenes can occur with the formation of chains of composition $\cdots(\text{C}:\text{CH}:\text{C})_n\cdots$ (analogous to the saturated chains produced by the macropolymerization of styrene according to Staudinger's formulation), or (3) acetylenes can unite directly to yield derivatives of *cyclobutadiene*. Since none of these possibilities corresponds to any of the courses of acetylene-polymerization which have been determined up to the present, it is convenient to consider acetylenes and olefine-acetylenes in the same section. In connexion with both of these molecular types it is to be borne in mind that differences in additivity are likely to exist between acetylenic units of the type $\text{C}:\text{CH}$ which retain an active or replaceable hydrogen atom, and those which do not, and further with respect to olefine-acetylenes that the course of reaction is likely to depend largely on the relative tendencies to additive reaction of acetylenic and olefinic centres.

Acetylenes. Unsubstituted acetylene polymerizes at low temperatures in the presence of ammonium and cuprous chlorides to give a dimeride (vinylacetylene), a trimeride (divinylacetylene), and a tetrameride (probably



[69, 1931]. With regard to the polymerization mechanism, the dimeride can definitely yield the tetrameride by self-addition under the conditions of reaction and appears to yield the trimeride by union with acetylene [69, 1931]. This

type of polymerization is restricted to compounds containing the group $\text{C}:\text{CH}$; consequently the trimeride and tetrameride are the ultimate products of reaction. The process may be represented as proceeding additively by the separation of hydrogen, the reaction (1) occurring in preference to (2):

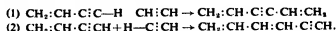

The polymerization of acetylene or alkylacetylenes by the end-to-end attachment of molecules would lead to the production of homogeneously conjugated chains, e.g. $\cdots\text{CH}:\text{CH}:(\text{CH}:\text{CH})_n:\text{CH}:\text{CH}\cdots$, which in view of the relative instability of known conjugated polyenes would hardly be expected to constitute the end products of reaction. Neither this type of reaction product nor any derived (cyclized or further polymerized) modification has been recognized.

The conversion of simple acetylenic compounds into benzenoid compounds by heat and by sulphuric acid has long been known to occur, but presumably the process begins by the formation of an open-chain dimeride and proceeds by one of the following routes:

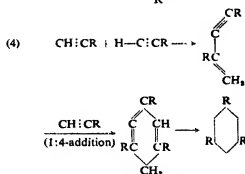
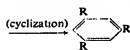
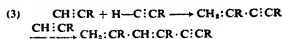

Mignonac and Ditz [66, 1934] report that acetylene, heated at 750° in a silica tube, gives not only much benzene, but a dimeride, C_6H_8 , which readily undergoes further polymerization on heating. Small quantities of benzenoid compounds have been obtained by the action of ultra-violet light on acetylene [43, 1931, 1933-4].

Olefine-acetylenes. It has been noted above that the catalytic polymerization of vinylacetylene (in presence of cuprous chloride) gives a dimeride which is probably $\Delta^{1:5:7}$ -octatriene-3-yne. The thermal polymerization of vinylacetylene, however, gives products whose structures are very difficult to determine. Some evidence has been obtained, nevertheless, which indicates that the products consist of *cyclobutane* and *cyclobutene* derivatives such as I, II, and III.

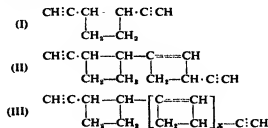

This, however, is not the only course of reaction: it is a striking fact that thermal polymerization of vinylacetylene in the presence of certain acidic materials (e.g. acids, acid anhydrides, and phenols) leads to the formation of styrene; some resinous products are also formed, but under suitable conditions half the polymeride consists of the dimeride, styrene. Thus vinylacetylene can undergo at least three distinct types of polymerization [25, 1934]:

Type	Catalyst	Structure	B.p. (30 mm.)	d_4^{20}	n_D^{20}
A	CuCl	$\text{CH}_2=\text{CH}-\text{C}(\text{C}(\text{CH}_3)=\text{CH})-\text{CH}=\text{CH}_2$	50°	0.830	1.576
B	None	$\text{CH}_2=\text{C}(\text{CH}_3)-\text{CH}=\text{C}(\text{CH}_3)-\text{CH}=\text{CH}_2$	50-3°	0.873	1.508
C	Acids	PhCH_2CH_2 	54°	0.907	1.545

The higher polymerides which accompany the respective dimerides or which are formed by direct polymerization of the latter also show pronounced differences. The higher polymerides of type A do not contain acetylenic hydrogen; on exposure to air they become insoluble, and when heated do not undergo depolymerization but decompose violently. The polymerides of type B contain acetylenic hydrogen; they become insoluble on exposure to air, and decompose explosively when heated above 110°. The higher polymerides of type C (polystyrene), as is well known, do not contain acetylenic hydrogen; they do not become insoluble on exposure to the air, and can be cracked by heat to yield styrene (see p. 959).

The mixed polymeride obtained by heating vinylacetylene in absence of a catalyst is a soft, light-coloured resin from which only small amounts of the dimeride can be separated by distillation. To this latter the structure I, analogous to those of the thermal polymerides of divinylacetylene (see below), is assigned. The higher polymerides decompose on attempted distillation, but from the nature of their hydrogenation products it is clear that a trimeride, two tetramerides, and a pentameride, in addition to 72% of higher polymeride, were formed. These probably are chain polymerides having the general structure III (p. 965).

Numerous acidic substances serve as catalysts for styrene production. By heating vinylacetylene for 6 hours at 105° in presence of 1-10% of catalyst, usually about 10-15% is converted into styrene; resinous by-products, however, are also obtained.

The manner of polymerization of divinylacetylene, a substance in which no acetylenic hydrogen remains, is of interest, since in many purely additive reactions an olefinic bond appears to be more readily reactive than an acetylenic bond. Divinylacetylene, when allowed to stand in air, is transformed to a soft, oxygen-containing jelly which is dangerously explosive [21, 1934]. The action of heat in the absence of air yields a quite different type of polymeride, viz. a yellow oil which dries to hard films. This oil is a mixture of polymerides from which *trans*-1:2-divinylethynyl-cyclobutane has been isolated, so that dimerization apparently proceeds in a manner analogous to the dimerization of cinnamic acid whereby threulic acid is formed.

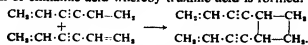

Addition, therefore, occurs at an olefinic bond and proceeds without hydrogen separation. A trimeride produced alongside the dimeride has probably the constitution:

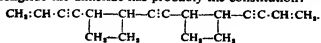

The 1-alkyl-2-vinylacetylenes, $\text{CH}_2=\text{CH}:\text{C}:\text{CR}$, are colourless liquids which slowly polymerize, yielding viscous, yellow syrups [41, 1933]. The 1-bromo-, 1-iodo-, and 1-chloro- β -vinylacetylenes are unstable liquids which polymerize on standing to black solid polymerides. The latter are explosive when heated or submitted to mechanical shock [42, 1933].

Allenes

Allene. The investigation of the polymerization of allenic hydrocarbons is chiefly due to Lebedev [55, 1913]. Allene itself, on heating in glass vessels for 3 days at 140°, is half-polymerized, yielding products ranging from the dimeride to the hexameride together with 25% of higher polymeric material. In all allenic dimerizations the two reacting molecules are considered by Lebedev to become linked at the central and at one of the extreme carbon atoms to give derivatives of cyclobutane. This may be regarded as the normal allenic mode of polymerization, and in the case of allene 1:2-dimethylene-cyclobutane (I) is formed.

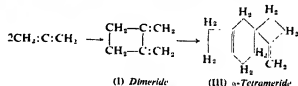

This dimeride, however, is itself a conjugated diene, and on heating undergoes both dimerization and high polymerization in the manner normal to this class of substance. Thus the α -form of tetrameric allene (III) is reported to be produced by the cyclohexene-forming type of dimerization which applies to the open-chain butadienes, and the high polymeride (IV) by the continued terminal linking of dimeride units in the manner usually considered to be characteristic of rubber formation from isoprene. To the trimeride, tetrameride (β -form), pentameride, and hexameride formed respectively by addition of monomeride to dimeride, to trimeride, &c., in the normal allene manner, the formulae (V), (VI), (VII), and (VIII) are assigned. All

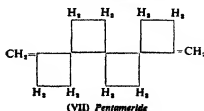
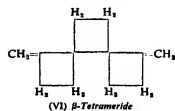
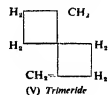
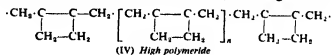

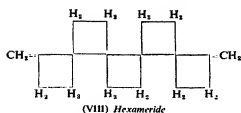

the lower polymerides are volatile liquids of boiling-point ranging from 63° (dimeride) to 170°/10 mm. (hexameride).

The mono-, di-, and tri-alkyl-allenes also polymerize, but in the case of all unsymmetrically substituted allenes the number of possible products is increased owing to isomerism. Thus *unsym.*-dimethylallene, $\text{CH}_2\text{:C:CMe}_2$, is reported to yield 3 dimerides, (IX), (X), and (XI), on heating [53, 1911], but none of the three theoretically possible ones of type (XII).

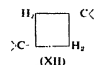
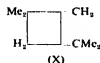

Amongst trimerides the form (XIII) is stated to be formed [54, 1913].

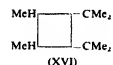
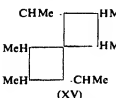
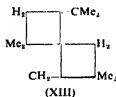

From *sym.*-dimethylallene the dimeride (XIV) and a small amount of trimeride (XV) are reported to be formed on heating, and from trimethylallene a mixture of isomeric dimerides (including XVI), trimerides, and higher polymerides. Triphenylallene yields a dimeride which Ziegler and his collaborators [106, 1924] identified as a tetraphenyltruxane, formed by further cyclization of an initially formed cyclobutane derivative (XVII or XVIII); this formulation, however, is not supported by Strauss and Ehrenstein [86, 1925], who attribute quite another constitution.

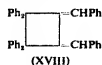
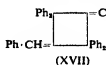

Cyclanes (Cycloparaffins, Naphthenes), C_nH_{2n}

The cyclanes are hydrocarbons in which the carbon chain forms a ring. Substituted cyclanes arise by replacement of the hydrogen atoms of the ring-methylene groups by other groups, the nomenclature adopted for the description of

such compounds depending on numbering the carbon atoms of the ring.

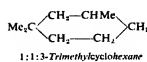
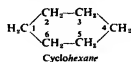

Occurrence.

Many petroleum, especially Russian petroleum, contain large proportions of saturated components possessing the general formula C_nH_{2n} , and apparently belonging to the cycloparaffin series. These substances, for the same reasons that apply in the case of the open-chain hydrocarbons of petroleum, are exceedingly difficult to isolate in homogeneous condition by fractionation processes, and as yet little information is available concerning the varieties and relative proportions of the individual hydrocarbons contained in the crude oils.

Markownikoff first recognized the presence of cyclohexane and of its monomethyl- and dimethyl-derivatives in the light naphtha of Russian petroleum, and suggested the term 'naphthenes' to describe the members of this group. Various other members of the cyclohexane group have been reported as identifiable in petroleum from different sources, but cyclopentane and its monoalkyl- and dialkyl-derivatives have also been identified in the lower fractions of Borneo, Russian, and other petroleum.

Certain crude petroleum also contain small quantities of cyclic carboxylic acids known as naphthenic acids which appear as sodium salts in the alkaline liquors employed in the refining of the crude oils. From an examination of various samples of naphthenic acids Zelinski in 1924 concluded that the great majority of these substances contained in petroleum are not derivatives of cyclohexane, but probably largely of cyclopentane. The isolation of an individual naphthenic acid from petroleum was first carried out by von Braun in 1933, who showed the compound to be 3:3:4-trimethylcyclopentylacetic acid,

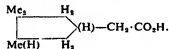

From the point of view, therefore, of petroleum chemistry the cyclanes containing 5- and 6-membered rings are of considerable importance, but those containing 3-, 4-, 7-, and higher membered rings are, so far as present information extends, only of theoretical interest.

Cyclohexane and Cyclopentane Series

Preparation.

Cyclohexanes. The cyclohexanes are for the most part prepared either by direct catalytic hydrogenation of the corresponding benzenoid compounds, or by catalytic hydrogenation of suitable cyclic olefines and diolefines, including hydrocarbons of the terpene group (see p. 971).

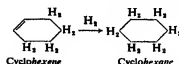
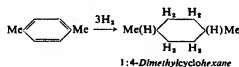

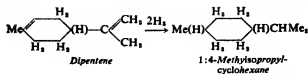

The cyclic alcohols obtained by the catalytic hydrogenation of phenol and its homologues in presence of nickel at temperatures in the neighbourhood of 180° (method of Sabatier and Senderens), or by the reduction of cyclic ketones, represent a fruitful source of materials for the preparation of cyclanes. These alcohols may either be dehydrated to yield the corresponding olefines (see p. 970) and thence converted into cyclanes by catalytic hydrogenation, or they may be first converted into the corresponding halogen compounds by the action of hydrogen halides or phosphorus halides and thence by direct reduction (or by elimination of hydrogen halide followed by catalytic hydrogenation) into the corresponding cyclic hydrocarbons. In the reduction of halogeno-cyclohexanes to cyclohexanes, reducing agents of the type of hydriodic acid and red phosphorus, zinc (or palladized zinc, or zinc-copper couple) and hydrochloric acid, and zinc dust and alcohol are employed.

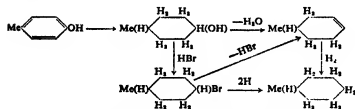

For the preparation of the more highly substituted cyclanes the Grignard reaction can be used. Thus by the interaction of magnesium alkyl halides (or zinc alkyls) with the ketones which are derivable in great variety by direct synthesis, by oxidation of cyclic alcohols, or by catalytic reduction of unsaturated ketones of the terpene series, alkylcyclohexanols are obtained: these are readily convertible into the corresponding hydrocarbons.

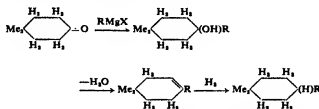

Alternative methods which may be utilized for the production of cyclohexanes in small quantities are those of Clemmensen, of Wolf, and of Kishner, whereby cyclic ketones are either reduced directly to the corresponding saturated hydrocarbons by boiling with amalgamated zinc and concentrated hydrochloric acid (Clemmensen), or are indirectly converted into these by heating their hydrazones or semicarbazones with sodium ethoxide (Wolf), or their hydrazones with potassium hydroxide (Kishner).

Cyclopentanes. The hydrocarbons of the cyclopentane group are almost invariably prepared from cyclopentanone and its homologues. Cyclopentanone is readily obtained by the dry distillation of calcium adipate or of a mixture of adipic acid and baryta, and this yields cyclopentanol on reduction with sodium amalgam or with similar reducing agents. Likewise alkylcyclopentanones may be derived by the distillation of the calcium salts of the alkyladipic acids,

and subsequently converted by reduction into the corresponding cyclic alcohols.

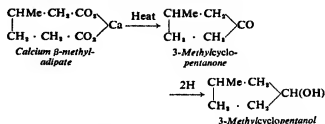

Cyclopentanones substituted in the 2-position may be obtained in two ways: (1) by direct alkylation of cyclopentanone or its homologues, using sodamide with an alkyl halide as alkylating agent, and (2) by alkylation of the cyclic sodio-keto-esters obtained by the action of metallic sodium on adipic esters (Dieckmann reaction), with subsequent hydrolysis and decarboxylation of the alkylated esters. The alkylcyclopentanones pass into alkylcyclopentanols on reduction.

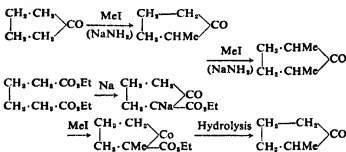

By dehydration of the cyclic alcohols cyclopentenes are obtained which pass into cyclopentanes on hydrogenation: the same result may be obtained by conversion of the cyclic alcohols first into the corresponding halides and thence by reduction into the hydrocarbons as in the case of the cyclohexanes.

For the preparation of small quantities of hydrocarbons directly from the cyclic ketones the methods of Clemmensen, of Wolf, and of Kishner may be employed as mentioned in connexion with the cyclohexanes.

Ring Transformations. Cyclic substances, especially those not purely of hydrocarbon type, are prone to undergo change of ring structure. Changes such as the conversion of cyclohexanes or alkylcyclobutanes into cyclopentanes occur with some readiness, especially in the case of reactions which are carried out at fairly high temperatures. A number of instances have been reported in which benzenoid hydrocarbons yield cyclopentane derivatives on hydrogenation at high temperature and pressure; moreover, reduction operations involving the use of hydriodic acid at temperatures between 200° and 250° appear frequently to be accompanied by change of cyclohexane into cyclopentane rings, and in the case of dimethyl-cyclobutyl-carbinol of a cyclobutane ring into a cyclopentane ring. One of the smoothest examples of ring transformation is that of 1-methyl-1- α -hydroxyethylcyclopentane to 1:2-dimethyl- Δ^1 -cyclohexene by the action of zinc chloride; and other

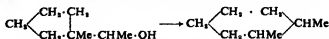

changes which do not require high temperatures are those of cyclobutyl-carbinol into cyclopentane by the reducing action of the zinc-palladium couple, and cyclohexane into methylcyclopentane by the action of aluminium chloride.

Properties.

The cyclohexanes and cyclopentanes are volatile liquids of petroleum-like smell which closely resemble the paraffins in general properties. They are attacked more or less readily by bromine, in sunlight or on heating, with the formation of substitution products, but reaction occurs with considerably greater ease when chlorine is employed in place of bromine: reaction then proceeds at room temperature in diffused light with formation of higher chlorides. By the action of bromine together with aluminium bromide on cyclohexanes, bromo-derivatives of benzenoid hydrocarbons have been obtained, and in certain cases direct dehydrogenation of cyclohexanes to benzenoid hydrocarbons has been achieved by passing the vapour of the hydrocarbons over heated finely divided nickel.

The cyclohexanes and cyclopentanes cannot be satisfactorily sulphonated with sulphuric acid, but they are usually susceptible of nitration, especially those hydrocarbons which contain tertiary hydrogen atoms. With nitric acid, however, nitration or oxidation may occur according to the conditions of reaction, and for the purpose of effecting nitration heating with diluted nitric acid at 115–20° is usually more satisfactory than treatment with the usual nitrating mixtures of concentrated nitric and sulphuric acids.

–34° c.). On heating at 400–500°, or at lower temperatures in presence of suitable contact substances, it passes into propylene. It is stable towards hot permanganate, but the ring is opened by fuming hydrobromic or hydriodic acids with formation of propyl bromide or iodide. Towards chlorine in the dark it is stable, but in sunlight explosion occurs; with moist chlorine chlorocyclopropane can be obtained. Although dry cyclopropane reacts only slowly in the dark with dry bromine, yet in sunlight it reacts rapidly with dry or moist bromine with formation of trimethylene dibromide. Bromination of cyclopropane in the presence of hydrogen bromide yields a mixture of 1:3- and 1:2-dibromopropane with some propyl bromide.

Methylcyclopropane (b.p. 4.5°) is obtained by debromination of 1:3-dibromobutane with zinc dust and alcohol. It is absorbed by concentrated sulphuric acid giving a mixture of polymerides; with 50% (by vol.) sulphuric acid, however, it yields *sec*-butyl alcohol.

1:1-Dimethylcyclopropane (b.p. 21°) is obtained by debromination of 1:3-dibromo-2:2-dimethylpropane with zinc dust and alcohol, and 1:1:2- and 1:2:3-trimethylcyclopropane are formed by analogous methods.

Cyclobutanes. Cyclobutane, $\begin{array}{c} \text{CH}_2 \cdot \text{CH}_2 \\ | \quad | \\ \text{CH}_2 \cdot \text{CH}_2 \end{array}$, is obtained by

Hydrocarbons of the Cyclopentane and Cyclohexane Series

	B.p.	d_4^{20}	n_D^{20}		B.p.	d_4^{20}	n_D^{20}
Cyclopentane	50–50.7°	0.7506 ²⁰	..	Cyclohexane	80–80.2°	0.7869 ¹¹	1.4291 ¹¹

Substituted Cyclopentanes

Substituent group	B.p.	d_4^{20}	n_D^{20}	Substituent group	B.p.	d_4^{20}	n_D^{20}
Methyl	70–72.2°	0.7474 ²⁰	1.4088 ²¹	1:1:2-Trimethyl	113–113.5°	0.7729 ¹⁸	1.4238 ¹⁸
1:1-Dimethyl	87.5°	0.7552 ²⁰	1.4139 ²⁰	1:1:3- "	115–16°	0.7703 ²⁰	1.4223 ²⁰
1:2- "	92.7–9.3°	0.7534 ²⁰	1.4126 ²⁰	1:2:3- "	114–15°	0.7688 ¹⁹	1.4230 ²⁰
1:3- "	90.5–91°	0.7497 ¹⁸	1.4110 ¹⁸	1:2:4- "	112–13°	0.7564 ²⁰	1.4156 ²⁰

Substituted Cyclohexanes

Substituent group	B.p.	d_4^{20}	n_D^{20}	Substituent group	B.p.	d_4^{20}	n_D^{20}
Methyl	103°	0.7695 ²⁰	1.4230 ²⁰	1:2:4-Trimethyl	140–1°	0.7799 ¹⁸	1.4311 ¹⁸
Ethyl	132–5°	0.7772 ²⁰	..	1:3:5- "	137.5°	0.7777 ¹⁹	1.4321 ¹⁹
<i>n</i> -Propyl	183–4°	0.8175 ¹⁸	1.4502 ¹⁸	1:2-Methylethyl	150–2°	0.7844 ²⁰	1.4323 ²⁰
1:1-Dimethyl	125°	(0.7851 ¹⁷) (0.7792 ²⁰)	1.4310 ¹⁷	1:3- "	148–9°	0.7896 ¹⁷	1.4353 ¹⁷
1:2- "	(128.6–129°) (122.5–123.5°)	0.7809 ¹⁷	1.4307 ¹⁸	1:3-Methyl- <i>n</i> -propyl	(160–70°) (164–5°)	0.7895 ²¹	..
1:3- "	119.5°	0.7867 ²⁰	1.4234 ²⁰	1:2-Methylisopropyl	171°	0.8135 ²¹	1.4472 ²¹
1:4- "	119.5–120°	0.7690 ²⁰	1.4244 ²⁰	1:3- "	167–8°	0.8023 ¹⁴	..
1:1:3-Trimethyl	138.5–139°	0.7664 ²⁰	1.4327 ¹⁷	1:4- "	171°	0.7974 ²⁰	1.4376 ²¹
1:2:3- "	141°	0.7898 ²⁰	1.4346 ²⁰	1:2:4:5-Tetramethyl	(169–70°) (160.5–161.5°)	(0.811 ²⁰) (0.7910 ¹⁸)	(1.4451 ²⁰) (1.4371 ¹⁸)

Cyclopropane and Cyclobutane Series

The hydrocarbons of these series are of little practical importance. Relatively to the cyclohexanes and cyclopentanes they are difficult to synthesize and possess an inferior degree of stability. None of the members of either series has been recognized in petroleum.

Cyclopropanes. Cyclopropane, $\begin{array}{c} \text{CH}_2 \\ | \quad | \\ \text{CH}_2 \end{array} \text{CH}_2$, is prepared

by the debromination of trimethylene dibromide by means of zinc dust and alcohol. It is a gas which liquefies at a carbon dioxide-ether freezing mixture (m.p. –126.6°; b.p.

the hydrogenation of cyclobutene (p. 970) in presence of nickel at 100°. It is a gas which liquefies at –15° (b.p. 11–12°; d_4^{20} 0.718) and is converted into butane on treatment with hydrogen at 200° in the presence of nickel. The ring system is stable towards cold concentrated halogen acids.

Methylcyclobutane (b.p. 39–42°) is obtained by the dehalogenation of 1:4-dibromohexane with sodium in toluene.

Cycloheptane and Higher Series

The saturated monocyclic hydrocarbons containing 7 or more carbon atoms in the ring are of considerable theoretical interest, but are not known to occur naturally. The synthesis of many cyclanes from C₇H₁₄ to C₂₀H₄₀ has been

effected by the reduction of the ketones or diketones formed by distillation of the salts (yttrium, thorium, cerium, zirconium) of open-chain dibasic acids [79, 1926, 1928].

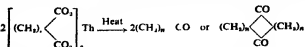

Cycloheptadecane and methylcyclopentadecane can be obtained by the reduction of civetone from civet and muscone from musk respectively.

The known higher cyclanes are crystalline solids which can be distilled (the higher ones at greatly reduced pressure) without decomposition.

The known cyclenes belong to many different series, containing from 4 to 17 carbon atoms in the ring. The cyclic alcohols from which the hydrocarbons are prepared are almost invariably obtained by reduction of the corresponding ketones, but in the *cyclohexane* series the alcohols may frequently be obtained directly by the catalytic hydrogenation of the corresponding phenols. In the case of certain dialkylcyclohexenes (menthenes), cyclenes may be obtained by the partial hydrogenation of diolefinic terpenes (menthadienes).

The cyclenes are volatile liquids of petroleum-like odour. In their physical properties, and in all their most important chemical properties, they closely resemble the correspond-

Higher Cyclane Hydrocarbons

		B.p.	M.p.			B.p.	M.p.
C ₇ H ₁₄	Cyclo-heptane	118°	13°	C ₁₁ H ₂₂	Cyclo-heptadecane	..	64-5°
C ₈ H ₁₆	" octane	149.6-150.6°	14.2-14.4°	C ₁₂ H ₂₄	" octadecane	..	72°
C ₉ H ₁₈	" nonane	170-2°	..	C ₁₃ H ₂₆	" docosane	212° (16 mm.)	45-6°
C ₁₀ H ₂₀	" dodecane	118° (18 mm.)	60-1°	C ₁₄ H ₂₈	" tetracosane	..	46-7°
C ₁₁ H ₂₂	" tridecane	112-13° (9 mm.)	17-18°	C ₁₅ H ₃₀	" hexacosane	218-19° (0.5 mm.)	41-2°
C ₁₂ H ₂₄	" tetradecane	143° (16 mm.)	52-3°	C ₁₆ H ₃₂	" octacosane	213-14° (0.25 mm.)	47-8°
C ₁₃ H ₂₆	" pentadecane	..	60-1°	C ₁₇ H ₃₄	" nonacosane	215° (1.1 mm.)	46-7°
C ₁₄ H ₂₈	" hexadecane	170-1° (20 mm.)	56-7°	C ₁₈ H ₃₆	" triacosane	..	55-6°

Cyclenes (Cyclic Olefines), C_nH_{2n-2}

The members of this group do not occur naturally, but are obtained synthetically in great variety by the action of dehydrating agents or dehydrating catalysts on cyclic alcohols or by the removal of hydrogen halide from the monohalogeno-derivatives of cyclanes (obtained by the action of hydrogen halides or phosphorus halides on the alcohols) by means of caustic alkalis or organic bases.

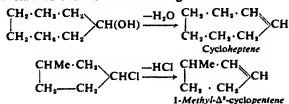

ing open-chain olefines. Allied to the cyclenes and resembling them in methods of formation and in chemical behaviour are the alkylidene-cyclohexanes (methylene-cyclohexane, ethylidene-cyclohexane, isopropylidene-cyclohexane, &c.) of the general formula (CH₂)_n-C=CRR'.

A hydrocarbon which appears to be *cyclobutene* has been obtained by the distillation of trimethyl-cyclobutylammonium iodide: it is a gas (b.p. 1.5-2°; *d*₄⁰ 0.733) which reduces permanganate in the cold, reacts readily with halogens, and passes on hydrogenation in presence of nickel at 100° into *cyclobutane*. Very numerous members of the *cyclopentene* and *cyclohexene* groups are known, but comparatively few hydrocarbons of the higher groups. The chief physical constants of the principal cyclenes are given in the subjoined table.

Cyclene Hydrocarbons

	B.p.	<i>d</i>	<i>n</i> _D		B.p.	<i>d</i>	<i>n</i> _D
Cyclobutene	1.5-2°	0.733 ₄ ⁰	..	1:3-Dimethyl-Δ ¹ -cyclohexene	124-6°	0.7998 ₂₂ ⁰	1.4466 ₂₁ ⁰
Cyclopentene	44.1-44.6°	0.7743 ₁₈ ⁰	1.4218 ₁₈ ⁰	1:3-Dimethyl-Δ ¹ -cyclohexene	126-7°	0.8074 ₁₈ ⁰	1.4508 ₁₇ ⁰
1-Methyl-Δ ¹ -cyclopentene	72°	0.7758 ₂₂ ⁰	..	1-Propyl-Δ ¹ -cyclohexene	154°	0.8381 ₁₈ ⁰	1.4579 ₁₉ ⁰
1-Methyl-Δ ² -cyclopentene	69°	0.7663 ₂₂ ⁰	1.4222 ₁₈ ⁰	1-Isopropyl-Δ ¹ -cyclohexene	156.5°	0.8220 ₁₉ ⁰	1.4615 ₁₉ ⁰
1:2-Dimethyl-Δ ¹ -cyclopentene	103-103.5°	0.7923 ₂₂ ⁰	1.4479 ₁₈ ⁰	1-Methyl-4-ethyl-Δ ¹ -cyclohexene	149°	0.8169 ₂₁ ⁰	1.4531 ₁₉ ⁰
1:1-Dimethyl-Δ ¹ -cyclopentene	78-78.5°	0.7580 ₂₂ ⁰	1.4190 ₂₀ ⁰	1:1:3-Trimethyl-Δ ¹ -cyclohexene	139-41°	0.7981 ₁₈ ⁰	1.4461 ₂₁ ⁰
1-Ethyl-Δ ¹ -cyclopentene	107-10°	0.7975 ₂₂ ⁰	1.4426 ₂₀ ⁰	1:2:3-Trimethyl-Δ ¹ -cyclohexene	149.6-150°	0.8347 ₁₇ ⁰	1.4631 ₁₇ ⁰
1:1:2-Trimethyl-Δ ¹ -cyclopentene	108.5-109°	0.7824 ₂₂ ⁰	1.4324 ₂₀ ⁰	1:3:5-Trimethyl-Δ ¹ -cyclohexene	142.5-143.5°	0.7965 ₂₁ ⁰	1.4447 ₂₁ ⁰
1:2:3-Trimethyl-Δ ¹ -cyclopentene	121.6°	0.8039 ₁₈ ⁰	1.4464 ₁₆ ⁰	1:2:4-Trimethyl-Δ ¹ -cyclohexene	144-6°	0.8078 ₁₈ ⁰	1.4501 ₁₉ ⁰
1:1:2:3-Tetramethyl-Δ ¹ -cyclopentene	134-5°	0.8035 ₁₈ ⁰	1.4441 ₂₀ ⁰	1-Methyl-4-isopropyl-Δ ¹ -cyclohexene	172-174.5°	0.8230 ₁₉ ⁰	1.4598 ⁰
1-Methyl-3-isopropyl-Δ ¹ -cyclopentene	138-9°	0.791 ₂₀ ⁰	1.4380 ₂₂ ⁰	1-Methyl-4-isopropyl-Δ ¹ -cyclohexene	168-9°	0.8130 ₂₀ ⁰	1.4523 ₂₀ ⁰
1:1-Diethyl-Δ ¹ -cyclopentene	144-6°	0.8083 ₂₂ ⁰	1.4469 ₂₀ ⁰	1:1:2:3-Tetramethyl-Δ ¹ -cyclohexene	169-72°	0.8217 ₁₄ ⁰	1.4601 ₁₄ ⁰
Cyclohexene	83-83.5°	0.8102 ₂₂ ⁰	1.4451 ₂₂ ⁰	1:2:4:5-Tetramethyl-Δ ¹ -cyclohexene	165-7°	0.8199 ₁₈ ⁰	1.4591 ₁₈ ⁰
1-Methyl-Δ ¹ -cyclohexene	108°	0.8099 ₂₂ ⁰	1.4496 ₂₀ ⁰	Cycloheptene	113-115°	0.8228 ₂₂ ⁰	1.4552 ₂₀ ⁰
1-Methyl-Δ ² -cyclohexene	104-6°	0.7986 ₂₂ ⁰	1.4431 ₁₈ ⁰	1-Methyl-Δ ¹ -cycloheptene	137.5-138.5°	0.824 ₁₉ ⁰	1.4581 ₁₉ ⁰
1:2-Dimethyl-Δ ¹ -cyclohexene	135.5-136.5°	0.8226 ₂₂ ⁰	1.4580 ₂₁ ⁰	Cyclooctene	145°	0.855 ₂₀ ⁰	1.474 ₂₀ ⁰
1:4-Dimethyl-Δ ¹ -cyclohexene	124-6°	0.7985 ₂₂ ⁰	1.444 ₂₀ ⁰	Cyclooctadecene	m.p. 36-7°
1-Ethyl-Δ ¹ -cyclohexene	135-6°	0.8238 ₁₈ ⁰	1.4567 ₁₆ ⁰	Cycloheptadecene	m.p. 47°
1:1-Dimethyl-Δ ¹ -cyclohexene	119.5-121.2°	0.8056 ₁₈ ⁰	1.4455 ₁₈ ⁰				

Cyclic and Semicyclic Dienes and Polyenes

With the exception of *cyclopentadiene* which occurs to a considerable extent in the fore-run of benzene from coal tar, and a number of monocyclic terpenes contained in various essential (vegetable) oils, the members of this group are prepared by synthetic means. For the most part they are obtained by the removal of hydrogen halide from dihalogeno-cyclanes, dihalogeno-cyclenes, or cyclic dihalogeno-dienes, either by the action of alkali or, more usually, by the exhaustive methylation method of Hofmann.

The conjugated cyclic dienes are remarkable in that they show no appreciable exaltation of the molecular refraction, the conjugated cyclic trienes only slight exaltation, and *cyclo-octatetraene* none at all [4, 1912].

Cyclopentadiene is of interest in that it contains a methylene group which by virtue of its position between doubly bound carbon atoms acquires a high degree of reactivity: the hydrogen atoms of this methylene group are replaceable by alkali metals and also readily react with the oxygen of ketones with formation of condensation products of the type $\text{C}=\text{C}$, known as fulvenes. With acetone, acetophenone, and benzophenone the following deeply coloured triene hydrocarbons are formed:

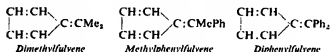

Both *cyclopentadiene* and the fulvenes are prone to undergo polymerization and atmospheric oxidation: *cyclopentadiene* passes rapidly into a mixture of polymerides, which consists largely of the dimeric hydrocarbon (p. 961).

Cyclohexadiene can exist in a conjugated ($\Delta^{1,3}$) and in a non-conjugated ($\Delta^{1,2}$) form. The former can be obtained in pure condition by the action of alcoholic sodium ethoxide on *cyclohexene dibromide* [37, 1925], and the latter, together with some proportion of its isomeride, by the action of alkali on 1:4-dibromocyclohexane, or by decomposition of the phosphate of 1:4-diaminocyclohexane.

Cycloheptatriene and *cyclooctatetraene*. $\Delta^{1,3,5}$ -*cycloheptatriene* (tropilidene), a liquid which readily resinifies in air, is obtained from *cycloheptene dibromide* by the Hofmann method, *cycloheptadiene* being obtained immediately. $\Delta^{1,3,5,7}$ -*Cyclooctatetraene* is prepared by the same method from N-methylgranatanin (I), the *cyclooctadiene* (V) which is first formed being converted successively into *cyclooctatriene* and *cyclooctatetraene*.

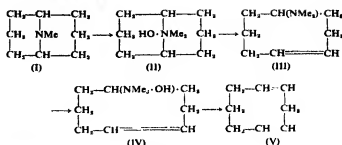

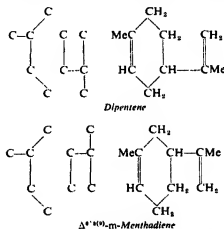

Monocyclic Terpenes, $\text{C}_{10}\text{H}_{16}$.

These diolefinic substances which are found in the essential oils of plants each contain the cyclized carbon skeleton of two isoprene units. When isoprene polymerizes to the dimeric stage, one of the monomeric molecules becomes added to the other in a way superficially analogous to that pursued in the addition of maleic anhydride to diene hydrocarbons (p. 950): the product is dipentene, the optically active forms of which (*d*- and *l*-limonene) are widely distributed in nature. But since the molecule of isoprene is unsymmetrical, the formation of dipentene represents only one of four ways in which the two monomeric molecules



could unite to give a substituted *cyclohexene* ring. A second of these ways is exemplified in the formation of 1-methyl-3-isopropenyl- Δ^1 -*cyclohexene* ($\Delta^{8,10}$ -*m*-menthadiene) which itself (or an isomeride thereof from which it is formed by facile double-bond displacement) occurs as *sylvestrene* in Swedish pine-needle oil. Modifications of dipentene in which both of the double bonds are in the ring occur naturally as α - and γ -terpinene and α -phellandrene, and

Conjugated Cyclic Dienes and Trienes

	Formula	B.p. ($^{\circ}\text{C}$)	d	n_D
<i>Cyclopentadiene</i>		40.2-41.6	0.8228 $^{\circ}$	1.4463 $^{16, 22}$
<i>Cyclohexadiene</i> (Dihydrobenzene)		78.3-78.8	0.8404 $^{20, 21}$	1.4756 20
<i>Cycloheptadiene</i>		120-1	0.8809 $^{\circ}$	1.4960 $^{17, 19}$
<i>Cycloheptatriene</i>		116	0.8876 $^{18, 19}$	1.5213 $^{18, 19}$
<i>Cyclooctatetraene</i>		36.2-36.4 (14 mm.)	0.925 20	1.5394 20

Monocyclic Terpenes

	Formula	B.p. (° C.)	<i>d</i>	<i>n_D</i>
α -Terpinene		180-2	0.8484 ¹⁶ *	1.4813 ¹⁶ *
γ -Terpinene		183	0.853 ¹⁶ *	1.4754 ¹⁶ *
α -Phellandrene*		175-6	0.8410 ²⁰ *	1.4732 ²⁰ *
<i>d</i> -Limonene*		176-176.4	0.8511 ²⁰ *	1.4743 ¹⁹ *
Terpinolene		183-5	0.854 ²⁰ *	1.484
β -Terpinene		173-4	0.838 ²⁰ *	1.4754 ²⁰ *
β -Phellandrene*		171-2	0.8520 ²⁰ *	1.4788 ²⁰ *
1- $\Delta^{1,101}$ -Menthadene*		172.5-173.5	0.8370 ²⁰ *	1.4704 ²⁰ *
<i>d</i> -Sylvestrene*		175-8	0.8485 ¹⁸ *	1.4572

* Optically active.

modifications in which the double bonds are otherwise displaced occur as β -phellandrene and β -terpinene. Other isomerides of dipentene, including *o*-, *m*-, and *p*-menthadienes, have been obtained synthetically.

In general chemical behaviour the monocyclic terpenes closely resemble the corresponding conjugated or non-conjugated diolefines, but in certain cases isomerization entailing double-bond displacement may occur with more than the usual facility.

Di- and Poly-cyclic Hydrocarbons (Saturated)

Dicyclic and polycyclic hydrocarbons are of many types, most of which can be regarded as built up by the fusion of separate rings in such a way that each ring has 1, 2, 3, or 4 carbon atoms in common with its neighbour. Systems



Fig. 1.



Fig. 2.

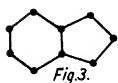

Fig. 3.



Fig. 4.



Fig. 5.



Fig. 6.



Fig. 7.



Fig. 8.

in which the fused rings have 1 carbon atom in common (e.g. the system shown in Fig. 1) are of *spirane* type; those in which the rings share 2 carbon atoms can be regarded

as composed of a single ring bridged by a valency bond (e.g. the ring-system in Fig. 2 is that of bicyclopentane, and the system in Fig. 3 that of a bicyclononane); and systems in which the rings share 3 or 4 carbon atoms (Figs. 4 and 5) are best viewed as composed of a single ring which is traversed by a bridge containing 1 or more carbon atoms. In bicyclic systems of the last type, however, it is immaterial which of the carbon-systems connecting the points of junction of the individual rings is regarded as the bridge, since all these connecting chains are equally free to distribute themselves in space: thus the systems represented in Figs. 7 and 8 are identical with that represented in Fig. 6.



Fig. 9.



Fig. 10.

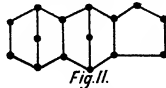

Fig. 11.

Numerous tricyclic and polycyclic hydrocarbons are known, and in many of these (e.g. the hydrocarbons whose carbon-skeletons are represented in Figs. 9-11, and the reduced polynuclear aromatic hydrocarbons in general) the fundamental ring-systems may attain a considerable degree of complexity.

The members of many of the important groups of dicyclic and polycyclic hydrocarbons are unsaturated compounds, and although fully saturated derivatives of these are often obtainable by the process of hydrogenation, the reduced compounds may be of slight importance. In the following account of the principal di- and poly-cyclic hydrocarbons reference is made only to those groups, whether saturated or unsaturated, which are themselves of some interest or importance.

Spirane Dicyclic Hydrocarbons.

Only two members of this group are known. *SpirocycloDecane* (cyclopentanespirocyclohexane) has been

obtained from the pinacol of cyclopentanone [104, 1929] and *spirocyclo*Undecane from *cyclohexanespirocyclohexane*-3:5-dione [70, 1926]. The former of these is reported to react

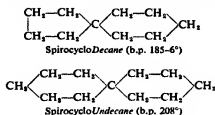

slowly with dilute permanganate, to give a tetrabromide with bromine, and to undergo isomerization in the presence of platinumized charcoal and hydrogen at 190°.

Dicyclohexanes.

The formation of bridged *cyclohexanes* has been reported by Zelinski and his collaborators and by Uspenski. The hydrocarbon is in each case obtained by debrominating a suitable dibromocycloane (the *cis*-isomeride appears to give the best results) with zinc dust and alcohol. Thus 3:5-dibromo-1:1-dimethylcyclohexane yields the dimethyl bicyclohexane (I) together with some proportion of an isomeric dimethylcyclohexene [101, 1913, 1920], and 1-bromo-2-bromomethylcyclopentane yields the dicyclohexane (II)

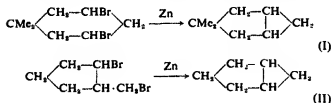

[103, 1924]; in a similar way 3:5-dibromo-1-phenylcyclohexane gives the corresponding phenyldicyclohexane III, and *cis*-1:4-dibromocyclohexane the dicyclohexane IV

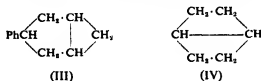

[87, 1920]. Another method of obtaining a bridged *cyclohexane* was discovered by Kishner [47, 1912], who obtained by the action of hydrazine on camphorophore a pyrazolone base, which yielded 2:6:6-trimethyldicyclohexane (V) on heating with caustic potash. One well-known member of

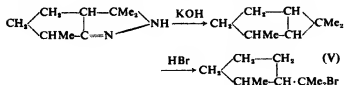

the group, however, is directly obtainable from naturally occurring products; thus thujane (VI) is easily obtained by the catalytic hydrogenation of any of the bicyclic terpenes α -thujene, β -thujene, and sabinene (p. 975).

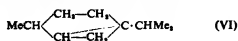

The *dicyclohexanes* are paraffin-like substances, stable towards cold permanganate, but attacked by concentrated hydrobromic acid with rupture of the cyclopropane ring. For the most part they are stable towards, or only slowly attacked by, bromine, but thujane is reported to give an unstable dibromide (presumably a *cyclohexane* derivative) with this reagent [46, 1910-11], and also to undergo transformation into the monocyclic hydrocarbon (VII) on dis-

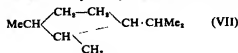

tillation over palladinized charcoal at 160-162° C. in a current of hydrogen [102, 1927].

Dicycloheptanes.

Various hydrocarbons having the formula $\text{C}_{10}\text{H}_{18}$ are known which are theoretically derivable, and in most cases actually derivable, by catalytic reduction (i.e. hydrogenation of the double bond) of the bicyclic terpenes. These substances are all dialkyl- or trialkyl-dicycloheptanes in which the basic ring structure is one of those represented in Figs. 1, II, and III below, and all save camphane are

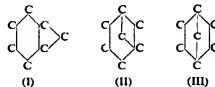

structurally capable of displaying optical isomerism. Another hydrocarbon, camphenilene, of composition C_9H_{16} , belongs to the same group.

The *dicycloheptanes* are colourless oils or solids, many of them possessing a pronounced odour.

Carane, b.p. 169.5°, is an optically active oil obtainable by dihydrogenation of d - Δ^2 -carene, and by heating pulegone hydrazone with sodium ethoxide or potassium hydroxide. It suffers fission of the cyclopropane ring by the action of hydrogen bromide, yielding a monocyclic hydrobromide (probably 8-bromo-*m*-menthane), and also by the action of bromine, yielding a dibromide (probably 4:8-dibrom-*m*-menthane).

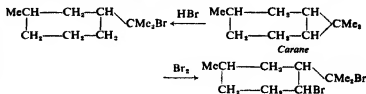

Pinene is an oil, obtained by the dihydrogenation of α - or β -pinene in the presence of platinum or nickel catalysts. Since the addition of hydrogen at the double bond of either form of pinene can take place in two ways, different stereoisomerides (*cis*- and *trans*-) may appear

in each case. Thus 1- α -pinene with a nickel catalyst at 220-230° C. yields *trans*-1-pinane (b.p. 162-4°) and with platinum black at the ordinary temperature *cis*-1-pinane (b.p. 164-8-165.8°); likewise d - α -pinene with platinum black yields *cis*- d -pinane (b.p. 163-4°). Pinane is remarkably stable both to oxidizing agents and to mineral acids and is only very slightly attacked by hydrogen bromide at 230° C.

Camphane, m.p. 153–4°, b.p. 160–1°, is the parent hydrocarbon of the camphor group, but it cannot be prepared by direct reduction of camphor. It is obtained in pure condition by the reduction of bornyl chloride, *isobornyl* chloride, or bornylene dichloride by sodium and alcohol, but owing to the symmetry of the molecule is optically inactive. It is a very volatile solid which shows great resistance to oxidizing agents and is not attacked by fuming sulphuric acid at 180°. With dilute nitric acid at 145–50° it yields two isomeric mononitro-derivatives.

Isocamphane is obtained by dihydrogenation of camphene at the ordinary temperature in presence of platinum black, or at 170–90° in presence of nickel. In this way *dl*- (m.p. 65–6°, b.p. 164.5°), *d*- (m.p. 62–3°, b.p. 166–166.5°), and *l*- (m.p. 63–64.5°, b.p. 164°) forms have been obtained. It yields a mononitro-derivative, m.p. 48–9°, on nitration.

Fenchane is an oil, b.p. 149°, obtained by the reduction of α -fenchene dibromide with sodium and alcohol, or by the action of sodium ethoxide or potassium hydroxide on *d*-fenchonehydrazide. With dilute nitric acid it yields a mixture of two *sec*-nitrofenchenes, but to some extent undergoes oxidation to *isofenchocamphoric* acid.

Isobornylane is obtained by the catalytic hydrogenation of α -fenchene or fenchone using the Sabatier-Senderens method, or by the dihydrogenation of *cyclofenchene* in presence of platinum black at 155–60°. It is an oil, b.p. 163.5–164.5°, which has not been obtained in pure *d*- and *l*-forms. With dilute nitric acid at 135–40° it gives two mononitro-derivatives (one *sec*.) together with *cis*-apocamphoric acid.

Camphenilane, m.p. 15–16°, b.p. 142.5°, is prepared by the action of potassium hydroxide on camphenilone hydrazone. It is extremely stable towards nitric acid, but at 140–5° yields with this reagent a mixture of nitro-derivatives and oxidation products.

Tricycloheptanes.

Three saturated tricyclic hydrocarbons belonging to the terpene series are known, viz. *cyclofenchene*, *tricyclene*, and *apocyclene*.

Cyclofenchene or β -pinolene is a slightly laevo-rotatory liquid (b.p. 143–143.5°) obtained to some extent during the dehydration of fenchyl alcohol. It is conveniently prepared by treating *d*-fenchone hydrazone with mercuric oxide in the presence of alkali. By treatment with hydrogen at 155–66° in presence of platinum black it yields *isobornylane*, and when passed over platinum black at 300° in a current of carbon dioxide it undergoes ring fission with formation of a mixture of α - and β -fenchenes. With bromine it gives α -fenchene dibromide, m.p. 86–7°, and with hydrogen chloride a rather unstable hydrochloride, m.p. 26–9°. On hydration it forms *isofenchyl* alcohol.

Tricyclene is a volatile solid (m.p. 67.5–68°, b.p. 153°) present in the camphene prepared by the dehydration of *isoborneol*. It may be prepared by the action of zinc dust on pinene dibromide or, better, by treatment of camphor hydrazone with mercuric oxide in presence of alkali. It is not attacked by permanganate, even on long boiling, but yields camphene hydrochloride with hydrogen chloride, and a mixture of borneol and *isoborneol* on hydration. On hydrogenation in presence of nickel at 180–200° it passes into *isocamphane*, the reaction evidently proceeding through camphene, since the latter is the product if tricyclene is passed over the same catalyst in a current of nitrogen.

Apocyclene is a solid hydrocarbon (m.p. 42.5–43°, b.p. 138–9°) obtained as a by-product in the preparation of *apobornylene* (q.v.). It is extremely resistant towards oxidizing agents.

Reduced Polynuclear Aromatic Hydrocarbons.

Many of the well-known polynuclear aromatic hydrocarbons have been converted into the corresponding fully saturated polycyclic compounds by the action of hydrogen in presence of nickel (at suitable temperatures and pressures), or by the action of energetic reducing agents. Amongst the saturated polycyclic hydrocarbons so obtained are the following:

		B.p. (° C.)	M.p. (° C.)
Decalindronaphthalene (Decalin)		185 (<i>trans</i>) 193 (<i>cis</i>)	
Tetradecahydroanthracene		270	93 61.5
Tetradecahydrophenanthrene		270.5	–3
Octadecahydrochrysene		253	115
Tetradecahydroretene		300–15	..
Dodecahydrofluorene		256–8	..

Polynaphthenes.

The high-boiling fractions of petroleum are complex mixtures consisting largely of hydrocarbons ranging from $C_{10}H_{16}$ to probably $C_{30}H_{48}$. The nature of these compounds is unknown, but doubtless they are of polycyclic nature. In the case of petroleum naphtha from Hodouin and Gbely (Czechoslovakia) it is reported that a hydrocarbon, adamantane, $C_{10}H_{16}$ (m.p. 68°), is contained in the fraction of b.p. 190 – 5° [51, 1933]. This substance is extremely stable towards oxidizing agents and has a terpenelike odour.

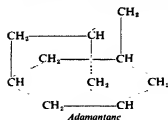
**Di- and Poly-cyclic Hydrocarbons (Unsaturated)**

The di- and poly-cyclic hydrocarbons of the unsaturated series include (1) the sesquiterpenes, (2) many partially reduced polynuclear aromatic hydrocarbons, and (3) the polymerides and addition products of cyclic dienes.

Dicyclic Terpenes.

The dicyclic terpenes occur extensively in the essential oils of plants, mostly *Coniferae*, but particularly in Swedish and Finnish oil of turpentine and in pine-needle oils. Certain members of the group are, however, obtained by chemical means from their derivatives. The following hydrocarbons are known:

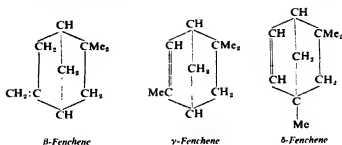
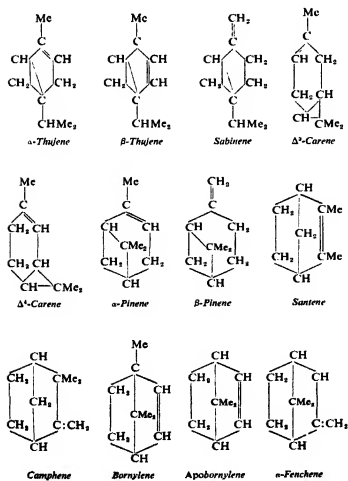

α -Thujene (b.p. 152 – 152.5°) forms the chief constituent of the oil from the gum-oleo-resin of *Boswellia serrata* Roxb., but is also obtainable (together with β -thujene) by distillation of the methyl xanthate of thujyl alcohol. It is optically active, but the *d*-form racemizes slowly on keeping. On hydrogenation in presence of platinum black it yields *d*-thujane, but when hydrogenated in presence of nickel at 180° fission of the cyclopropane ring occurs, with formation of 1:2-dimethyl-3-isopropyl-cyclopentane. The cyclopropane ring is also ruptured by hydrogen chloride and by hydrogen bromide with formation of the corresponding terpinene dihalides; further, with dilute sulphuric acid the hydrocarbon yields a mixture of 1:4-terpin and terpinen-4-ol.

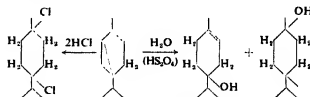

β -Thujene (b.p. 147°), obtained together with its α -isomeride by heating the methyl xanthate of thujyl alcohol, gives thujane on catalytic hydrogenation. It is remarkably resistant to oxidation by potassium permanganate, but the cyclopropane ring suffers fission on treatment with dilute sulphuric acid or with halogen acids.

Sabinene (b.p. 163 – 5°), obtained in the *dextro*-form from oil of savin (*Juniperis sabina* L.) and in the *laevo*-form from several sources, yields thujane on hydrogenation in presence of platinum black, but 1:2-dimethyl-3-isopropyl- Δ^2 -cyclopentene on hydrogenation in presence of colloidal palladium. It forms a liquid dibromide with bromine.

Δ^4 -Carene (b.p. 170°), from oil of turpentine, oxidizes with great ease and resinifies on exposure to air. It yields carane on hydrogenation in presence of platinum black and undergoes ring fission with formation of sylvestrene and dipentene dihydrochlorides on treatment with hydrogen chloride.

Δ^2 -Carene (b.p. 165 – 7°), from oil of turpentine, oxidizes more slowly than its Δ^4 -isomeride, but undergoes fission of the cyclopropane ring with hydrogen bromide.

α -Pinene (b.p. 156°), present in most essential oils from *Coniferae*, is known in *d*-, *l*-, and *dl*-forms. It oxidizes in air, a peroxide being first formed. When passed through a hot tube it yields some isoprene, when vaporized over metals (Cu, Ni, Co, and Fe) it yields aromatic hydrocarbons, and when heated it undergoes isomerization to dipentene.

β -Pinene (b.p. 162 – 3°) usually accompanies α -pinene in essential oils and, like its isomeride, yields pinane on hydrogenation.

Camphene, the only naturally occurring dicyclic terpene which is crystalline (m.p. 51 – 2° , b.p. 158 – 5 – 159 – 5°), occurs

in *d*-, *l*-, and *dl*-forms which are fairly widely distributed. It can be prepared from turpentine by treatment with hydrogen chloride and removal of hydrogen chloride from the bornyl chloride so formed; it can also be obtained by removal of hydrogen chloride from *isobornyl* chloride and by dehydration of borneol or *isoborneol*.

Camphene shows a marked tendency to undergo intramolecular change. It does not react smoothly with chlorine or bromine, and with hydrogen chloride gives *isobornyl* chloride, thus undergoing the Wagner-Meerwein rearrangement—an isomerization essentially of the type

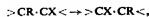

where X is an anionic group (e.g. Cl or OH) and R, in which the isomerization occurs, is a kationic hydrocarbon radical (e.g. the cyclyl radicals shown in skeleton below).

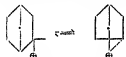

With a mixture of sulphuric and acetic acid it is hydrated, yielding *isobornyl* acetate.

Bornylene does not occur in nature, but is obtained by distillation of the methyl bornylxanthate (not by direct dehydration of borneol, which gives camphene) or by distillation of bornyltrimethylammonium hydroxide. It is a volatile, optically active solid (m.p. 113°, b.p. 146°) which gives a crystalline nitrosite (m.p. 163°) and passes on catalytic hydrogenation in presence of nickel at 170–90° into camphene.

Apobornylene is a solid (m.p. 35.5–36°, b.p. 136–7°) with an odour resembling that of camphene. It is formed by the distillation of methyl camphenylxanthate.

Santene is an oil (b.p. 140–1°) of somewhat unpleasant odour which occurs in East Indian sandalwood and in pine-needle oils. It resinifies rather readily in the air and gives both a crystalline nitroso-chloride (m.p. 109–10°) and a nitrosite (m.p. 123–6°).

The Sesquiterpenes.

The hydrocarbons of the sesquiterpene series are compounds of composition $C_{15}H_{24}$, which occur in essential oils. As with the terpenes their carbon skeletons can be regarded as built up of isoprene units (3 units in this case) which may be arranged in several ways. So far as has been shown at present, all sesquiterpenes contain the carbon skeleton of a naphthalene ring or of a potential naphthalene ring, and various members of the group have been found to yield either cadalene (1:6-dimethyl-4-*isopropyl*naphthalene) or eudalene (1-methyl-7-*isopropyl*naphthalene), containing a methyl group less than cadalene, on dehydrogenation with sulphur.

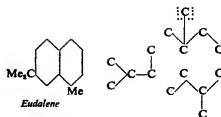
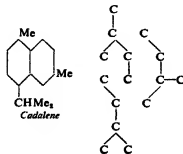

The sesquiterpenes, therefore, differ from one another in the arrangement of the three isoprene units, the degree of cyclization (mono- or di-cyclic), and the disposition of the double bonds. Up to the present the formulae of bisabolene and zingiberene (monocyclic), cadinene and selinene (dicyclic), and copaene and α -santalene (tricyclic) have been established, but extensive researches have also been carried out on the constitutions of the caryophyllenes and of β -santalene.

Monocyclic Hydrocarbons. Bisabolene is a colourless oil (b.p. 133–4°/12 mm.) found in oil of bergamot, and zingiberene an oil (b.p. 134°/14 mm.) which forms the main constituent of ginger oil.

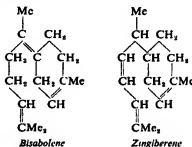

Dicyclic Hydrocarbons. Cadinene, forming the main constituent of oil of cubeb, and selinene, found in celery oil, are colourless oils boiling at 134–6°/11 mm. and at 136–9°/17 mm. respectively. Cadinene is almost certainly to be represented by formula I or II below, and probably is a mixture of both the hydrocarbons to which these formulae apply. The caryophyllenes are oils which form the main hydrocarbon constituent of oil of cloves.

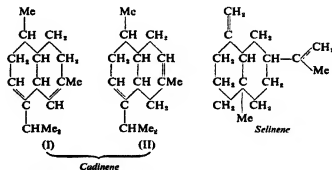

Tricyclic Hydrocarbons. Copaene is a colourless oil (b.p. 119–20°/10 mm.) found in African oil of copaiba, and the two santalenes (α - and β -) are oils which, together with santene (see above) and nortricycloekasantalene, $C_{17}H_{26}$, form the hydrocarbon constituent of East Indian sandalwood oil. The constitution of α -santalene (b.p. 118°/7 mm.) is now known, but that of β -santalene (b.p. 125–6°/7 mm.) has not yet been fully established; there is some probability, however, that β -santalene is to be represented by the formula (III) below.

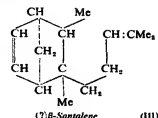
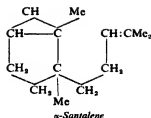
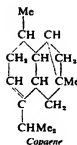

Partially Reduced Polynuclear Aromatic Hydrocarbons.

Numerous partial-reduction products have been obtained from polynuclear aromatic hydrocarbons by the action of energetic reducing agents (hydriodic acid and red phosphorus or sodium and alcohol), or by catalytic hydrogenation in the presence of nickel or nickel oxide at suitable temperatures and pressures. In many cases the constitutions of the hydrides have not been exactly determined, and in not a few cases isomeric hydrides arise or can be obtained from the reduction products by displacement of double bonds. These substances are attacked with widely varying degrees of ease by chlorine, bromine, nitric acid, sulphuric acid, and chromic acid. A list of the more important compounds is given below.

Parent hydrocarbon	Hydro-derivative	M. p. ($^{\circ}$ C.)	B. p. ($^{\circ}$ C.)
Naphthalene	Δ^1 -Dihydro-	15	212
"	Δ^2 -Dihydro-	-7	..
"	1:2:3:4-Tetrahydro-	-30 to -27	206-8
Anthracene	9:10-Dihydro-	107-9	..
"	1:2:3:4-Tetrahydro-	103-5	..
"	<i>p</i> -Octahydro-	73-4	..
"	Decahydro-	30-5	147-52 (10 mm.)
Phenanthrene	2:7:9:10-Tetrahydro-	0	300-4
Reiene	Tetrahydro-	..	128 (50 mm.)
"	Dodecahydro-	..	336
Chrysene	Hexadecahydro-	..	360
Acenaphthene	3:4:5:11-Tetrahydro-	..	254

Complex Polymerides.

Various complex cyclic structures are obtained by the polymerization of diene and polyene hydrocarbons as instanced by the polymerides of *cyclopentadiene* and *cyclohexadiene* (p. 961). Substances of sesquiterpene or more highly cyclized type are formed by the addition of diolefines to terpenes.

Aromatic Hydrocarbons

Many different types of compound are included under the general designation *aromatic hydrocarbons*, but the members of all the different classes are alike in containing at least one benzene nucleus (see below) in the molecule. All aromatic hydrocarbons, therefore, may be regarded as derivatives of benzene, the differences between the various

groups into which these substances are broadly classified depending on differences in the number, nature, and method of attachment of the individual rings present. Certain of the hydrocarbons considered below are only partially aromatic in character. Many of the more complex polynuclear hydrocarbons have little practical importance and are omitted from this description. The following classification is employed:

<p><i>Mononuclear hydrocarbons</i></p> <p>Benzene group</p> <p><i>Binuclear hydrocarbons</i></p> <p>Diphenyl group</p> <p>Diphenylmethane group</p> <p>Naphthalene group</p> <p>Indene group</p>	<p><i>Tri- and poly-nuclear hydrocarbons</i></p> <p>Anthracene group</p> <p>Phenanthrene group</p> <p>Fluorene group</p> <p>Triphenylmethane group</p> <p>Higher polynuclear hydrocarbons</p>
--	---

Benzene Group

The parent compound of this group is benzene, C_6H_6 , which from the time of Kekulé (1865) has been recognized as composed structurally of 6 carbon atoms linked together in a ring, each carbon having attached to it a hydrogen atom. During the history of organic chemistry there have been innumerable speculations as to the exact manner in which the fourth valence of carbon is disposed in the 6-carbon ring or nucleus (I): these cannot be considered

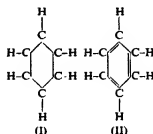

here, and it is sufficient for the present purpose to adopt Kekulé's representation of benzene which above all others agrees most consistently with the chemical behaviour of benzenoid substances. According to Kekulé's hypothesis benzene is to be regarded as a *cyclohexatriene* in which the double bonds alternate with single bonds, that is to say, it is the conjugated or $\Delta^{1,3,5}$ -form of *cyclohexatriene* (II); moreover, according to the hypothesis the homologues and other derivatives of benzene are theoretically derivable by substitution of the hydrogen atoms of the nucleus by alkyl or other groups.

Since, however, pairs of isomeric mono-substituted and di-substituted benzenes of the types (A) and (B) (R and R' are substituents) have never been observed to occur among benzenoid compounds, or have indeed been obtained by direct attempts at synthesis,

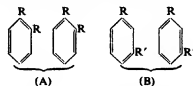

the existence of a dynamic form of isomerism between the two Kekulé 'individuals' or 'phases' is to be assumed.



Although this type of isomerism which postulates a Venetian shutter-like interchange of the isomeric forms was originally regarded as a property peculiar to the benzene ring, it is to-day regarded merely as a special case of tautomerism. There is, however, recent direct chemical evidence

of the simultaneous occurrence of both individuals in *o*-xylene, which on ozonolysis yields all of the fragments to be expected according to the dynamic hypothesis, viz. pyruvic aldehyde, glyoxal, and diacetyl [59, 1932].

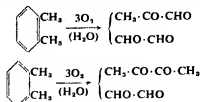

Isomerism. If one of the hydrogen atoms of benzene is replaced by another element or group, the resulting mono-substitution product exists in only one form; thus there is one chlorobenzene, $\text{C}_6\text{H}_5\text{Cl}$, one methylbenzene, $\text{C}_6\text{H}_5 \cdot \text{CH}_3$, &c. Since, according to Kekulé's hypothesis, all the hydrogen atoms in benzene are equivalent, it is immaterial which position in the benzene nucleus is assigned to the single substituent.

If, however, two hydrogen atoms of benzene are replaced by two monovalent elements or radicals, the relative positions of the substituents are of considerable importance in determining the properties of the compound. All the di-substitution products of benzene exist in three isomeric forms, the position of the second substituent with reference to the first being described either by quoting the numbers of the carbon atoms to which the substituents are attached (the nuclear carbon atoms are numbered in rotation as shown in the formulae below) or by employing the prefixes *ortho*-, *meta*-, and *para*- (contracted to *o*-, *m*-, and *p*-) to describe the 1:2-, 1:3-, and 1:4-disubstituted compounds respectively.

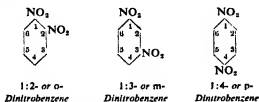

When the hydrogen atoms of benzene are replaced by three monovalent elements or groups the number of isomeric trisubstitution products depends on whether the substituents are the same or different. If the substituents are the same, there are three isomerides distinguished as 1:2:3 (*vicinal*), 1:2:4 (*unsymmetrical*), and 1:3:5 (*symmetrical*); if, on the other hand, the substituents are not all alike, then either six or twelve isomerides are possible according to whether two of the substituents are identical and one is different, or all of the substituents are different. Similar considerations apply to the number of tetra-, penta-, and hexa-substituted benzenes which are theoretically possible when the substituents are either all identical or are partly or wholly different.

Occurrence. Benzene and its methyl homologues occur extensively in the tar obtained by dry distillation of coal at temperatures above $1,000^\circ\text{C}$. The *light oil* fraction of the tar (b.p. 80 – 170°) consists principally of benzene, toluene, and xylene, together with smaller proportions of pseudocumene and mesitylene, the individual hydrocarbons being separated by a procedure involving repeated fractional distillation of the oil, and washing of the earlier distillates successively with concentrated sulphuric acid and with caustic soda to remove basic and phenolic substances. Although coal tar forms the principal source of benzenoid

hydrocarbons, yet benzene and various of its homologues are to be found among the pyrolysis products of petroleum hydrocarbons and can in certain cases be obtained by thermal and by sulphuric acid treatment of acetylenes.

Benzene and other hydrocarbons of the 'aromatic' series are also present in many crude petroleum (see article by B. T. Brooks in this section). Borneo (Koeter) petrol containing the exceptionally high proportion of 40%. The 'petrol' fraction of petroleum from Russia, Iran, and Burma contain between 10 and 20% of aromatic hydrocarbons boiling within the range 80 – 200°C ., while naphthalene and its homologues have been isolated from petroleum distillates of higher boiling-point.

Preparation. Benzene is formed when acetylene is heated at a dull red heat,



and can be prepared by heating benzoic acid or sodium benzoate with soda-lime.



The homologues of benzene can be obtained in the following ways:

(1) By dry distillation of aromatic carboxylic acids with alkali—a method analogous to that for the preparation of benzene from sodium benzoate and caustic soda.



(2) By the action of sodium upon a mixture of a brominated benzene hydrocarbon and an alkyl iodide or bromide. This method, due to Flitig, is an extension of the Wurtz method for the preparation of paraffins by the action of sodium on alkyl halides.

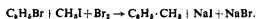

(3) By the action of organomagnesium derivatives (or zinc alkyls) on alkyl halides or alkyl sulphates.

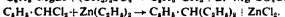
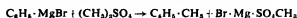

(4) By hydrogenation of styrene and its homologues (p. 980).

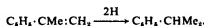

(5) By the action of alkyl halides on aromatic hydrocarbons in presence of anhydrous aluminium chloride (method of Friedel and Crafts).

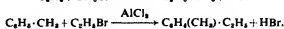
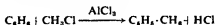

There is no difficulty in replacing all the hydrogen atoms of benzene by alkyl groups, but difficulty is often experienced in stopping the reaction at the required point and also in separating the mixture of isomerides formed. Zinc chloride, and especially ferric chloride, can act in a manner similar to that of aluminium chloride.

Synthetic processes of the above type can frequently be reversed in presence of aluminium chloride. Thus, under suitable conditions, it is possible to detach the side chains from one molecule of hydrocarbon and introduce them into another molecule of the same hydrocarbon; but certain positions of the alkyl groups appear to be favoured both in the degradative and synthetic processes. In the presence of aluminium chloride the alkyl radicals of butyl- and amyl-benzenes may undergo rearrangement (cf. p. 942).

(6) By the action of olefins on benzene or its homologues in the presence of aluminium chloride:

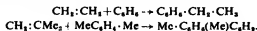

The reaction may be regarded as an addition of the aromatic hydrocarbon at the double bond of the olefine, and in the case of benzene may be continued until hexaethylbenzene is produced.

(7) By the replacement of the inorganic residues in certain of the substitution products of benzene and its homologues by hydrogen. Thus sulphonic acids give the corresponding hydrocarbons when treated with superheated steam in presence of sulphuric acid, concentrated hydrochloric acid, or phosphoric acid, at 180°.

Phenols and aromatic ketones give benzenoid hydrocarbons when heated with zinc dust; the ketones, moreover, are often smoothly converted into hydrocarbons when their vapours are passed over finely divided nickel at 190–5°.

The (solid) diazonium salts derived from benzenoid hydrocarbons yield the free hydrocarbons when they are heated with absolute alcohol. A more convenient and satisfactory method for attaining the same result consists in the conversion of the diazonium salts, first into hydrazines by the reducing action of stannous chloride and concentrated hydrochloric acid, and then into the corre-

sponding hydrocarbons by heating the hydrazines with a solution of copper sulphate or ferric chloride:

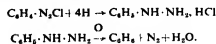

Physical Properties. The hydrocarbons of the benzene group are colourless liquids with an odour resembling that of benzene. The boiling-points rise by increments of about 24–30° when a methyl group is introduced into the aromatic nucleus, and by increments of about 24° when the same group is introduced into a side chain. The molecular refraction of benzene and its homologues shows no exaltation in spite of the presence in the molecule of three conjugated double bonds. A list of the principal hydrocarbons of the benzene group is given in the table.

Reactions.

Additive. As might be expected of substances possessing a cyclohexatriene constitution the benzenoid hydrocarbons display additive properties. This type of reactivity is, however, not well developed.

(1) In sunlight benzene adds 6 atoms of chlorine or bromine, forming benzene hexachloride and benzene hexabromide (hexachlorocyclohexane and hexabromocyclohexane) respectively.

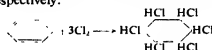

(2) Under the action of ozone, benzene and its homologues give explosive trioxides, which are decomposed by water with formation of aliphatic aldehydes.

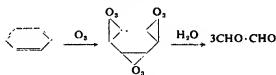

(3) When heated with hydrogen in presence of finely divided nickel the benzenoid hydrocarbons give cyclanes (cyclohexanes). Such hydrogenations are usually carried out at considerably increased pressures; e.g. at 200° and 76 atm. pressure benzene is reduced to cyclohexane. Good results, however, are obtained in the reduction of benzene, toluene, ethyl benzene, *m*-xylene, and many other hydrocarbons by employing a platinum oxide-platinum black catalyst in a glacial acetic acid medium at 2–3 atm. pressure.

Reduction of benzenoid hydrocarbons may usually be effected by heating with hydrogen iodide and red phosphorus in a sealed tube, but by this method the cyclohexanes which would normally be produced frequently undergo transformation into cyclopentanes.

(4) Benzene and toluene when heated at 130–5° with ethyl diazoacetate in a sealed tube yield ethyl norcaradiene-carboxylate and ethyl methylnorcaradiene-carboxylate respectively.

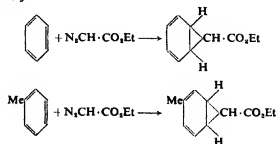

Benzenoid Hydrocarbons

	M.p. (°C)	B.p. (760 mm.) (°C)	d_4^{20}
Monosubstituted benzenes:			
Benzene	5.4	80.18	0.8799
Toluene	-92.4	110.8	0.8656
Ethylbenzene	-92.8	136.18	0.8673
<i>n</i> -Propylbenzene	158	0.8617
<i>iso</i> Propylbenzene (Cumene)	153	0.8620
<i>n</i> -Butylbenzene	180	0.8612
<i>iso</i> Butylbenzene	167	0.8596
<i>sec.</i> -Butylbenzene	174	0.8625
<i>tert.</i> - "	168	0.8671
Disubstituted benzenes:			
<i>o</i> -Xylene	-29	144.6	0.8812
<i>m</i> - "	-54	139	0.8655
<i>p</i> - "	15	138	0.8611
<i>o</i> -Methylethylbenzene	164.8–165	0.8841 ^{16, 27}
<i>m</i> - "	161.5–162.5	0.8690 ^{17, 28}
<i>p</i> - "	162.5	0.8601 ^{17, 28}
1:2-Methylisopropylbenzene	175	0.8740 ²⁹
1:3- "	175	0.8590 ²⁹
1:4- "	-75	177.3	0.8568
(Cumene)			
Tri- and poly-substituted benzenes:			
1:2:3-Trimethylbenzene	175.3	0.8949
1:2:4- "	-60.5	169.3	0.8764
(Pseudo-cumene)			
1:3:5-Trimethylbenzene	-53.5	164.8	0.8634
(Mesitylene)			
1:2:3:4-Tetramethylbenzene	-4	203–4	0.9044 ^{10, 30}
1:2:3:5- "	195–7	0.8961 ^{10, 30}
(Isodurene)			
1:2:4:5-Tetramethylbenzene	79	191–2	0.8380 ^{31, 32}
(Durene)			
Pentamethylbenzene	53	231	0.8472 ^{10, 32}
Hexamethyl- "	164	264	0.8985 ^{10, 32}
Pentamethyl- "	277	0.8985 ^{10, 32}
Hexamethyl- "	129	298	0.8305 ^{130, 40}

Substitution. The hydrogen atoms of the nucleus are replaced by other atoms and groups with such readiness that substitution reactions are especially characteristic of aromatic hydrocarbons. The following are the most important processes:

(1) At ordinary temperatures, in absence of direct sunlight, benzene and its homologues give substitution products such as chlorobenzene, C_6H_5Cl , bromobenzene, C_6H_5Br , and dichlorobenzene, $C_6H_4Cl_2$, with chlorine and bromine. This reaction proceeds only slowly, but is greatly hastened by the presence of a halogen carrier such as iodine, iron, aluminium, &c.

The homologues of benzene are capable of undergoing two kinds of substitution reaction. Although at ordinary temperatures in absence of direct sunlight they are converted into substitution products by displacement of hydrogen of the nucleus, the reaction being assisted by the presence of a halogen carrier, yet when they are treated with chlorine and bromine at their boiling-points, or in direct sunlight, they give derivatives by substitution of the hydrogen of the side chain. Thus when chlorine is passed into boiling toluene, benzyl chloride, $C_6H_5 \cdot CH_2Cl$, benzylidene chloride, $C_6H_5 \cdot CHCl_2$, and benzoic chloride, $C_6H_5 \cdot CCl_2$, are formed.

(2) With concentrated nitric acid (sp. gr. 1.3-1.5), or often more readily with mixtures of concentrated sulphuric and nitric acids, the benzenoid hydrocarbons undergo nitration, that is to say, the nuclear hydrogen atoms of the hydrocarbons (1 or more) are replaced by the nitro-group, $\cdot NO_2$.

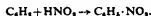

When a large excess of the reagent is used, and especially when heat is applied, the aromatic compound is usually converted into dinitro- or trinitro-derivatives. In nearly all cases where the benzene nucleus after nitration contains two or more substituent groups, mixtures of isomeric products are formed. Thus benzene yields a mixture of *o*-, *m*-, and *p*-dinitrobenzene, the principal product being the *m*-compound. Similarly, toluene gives a mixture consisting almost exclusively of *o*- and *p*-toluenes.

(3) Benzenoid hydrocarbons gradually dissolve when heated with concentrated sulphuric acid with formation of sulphonic acids; in this way benzene gives benzenesulphonic acid and toluene a mixture of *o*- and *p*-toluenesulphonic acids.

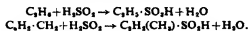

When fuming sulphuric acid is used in place of ordinary concentrated sulphuric acid at suitable temperatures, mixtures of isomeric di- and tri-sulphonic derivatives may be obtained.

Oxidation. Although benzene shows very great stability towards oxidizing agents in spite of its double-bonded structure, and only suffers oxidation under very drastic conditions, yet alkylbenzenes readily undergo oxidation at the side chains on heating with dilute nitric acid, chromic acid mixture, potassium permanganate, or potassium ferricyanide. The side chains, whether consisting of methyl, ethyl, or higher alkyl groups, invariably become oxidized to carboxyl groups, and consequently when more than one side chain is attached to the nucleus, di- or poly-carboxylic acids are formed.

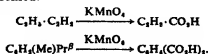

Benzene Hydrocarbons with Unsaturated

Side Chains

(1) Arylolefines (Olefine Benzenes).

The monoalkylbenzenes may be regarded as arylparaffins, since the side chains attached to the nucleus are saturated. Many hydrocarbons are known in which an olefinic group is attached to the nucleus, and these can be regarded either as olefino- or alkylene-benzenes, or as arylolefines. Typical of the members of this group are styrene (phenylethylene, or vinylbenzene), α -methylstyrene (2-phenylpropene), and β -methylstyrene (1-methylpropane).

	Formula	B.p. ($^{\circ}C$)
Styrene	Ph \cdot CH:CH ₂	146
α -Methylstyrene	Ph \cdot CMe:CH ₂	162
β -Methylstyrene	Ph \cdot CH:CHMe	192
1-Phenyl-1-methylbutene	Ph \cdot CMe:CHEt	199
1-Phenyl-2-isopropylethylene	Ph \cdot CH:CH \cdot CHMe ₂	207
1-Phenyl-1-methylhexene	Ph \cdot CMe:CH \cdot Bu ^a	210

(20 mm.)

Preparation. Since arylolefines are obtainable by many of the general methods for the preparation of olefines their preparation need not be further described. Styrene occurs to the extent of 1-5% in storax and is present in the crude xylene from coal tar. It is formed by polymerization of acetylenes (p. 965) and occurs amongst the pyrolysis products of the lower paraffin hydrocarbons [14, 1934], where its presence appears to result from the addition of ethylene to the benzene formed during pyrolysis, followed by dehydrogenation [9, 1934]:

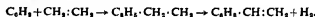

Properties. The arylolefines display the characteristic additive properties, including polymerization (p. 956), of aliphatic olefines, but in some cases secondary reactions resulting in substitution of the aromatic nucleus occur.

(2) Arylacetylenes (Acetylene Benzenes).

The simplest and best-known hydrocarbon of this group is phenylacetylene, PhC:CH, b.p. 139 $^{\circ}$, which is obtained (1) by heating phenylpropionic acid with water at 120 $^{\circ}$, or alternatively by distilling its barium, aniline or copper salt, with steam, and (2) by the action of alcoholic caustic potash on α -bromostyrene or acetophenone chloride at 130 $^{\circ}$.

Phenylmethylacetylene, Ph \cdot CMe (b.p. 185 $^{\circ}$), phenylethylacetylene, PhC:CEt (b.p. 201 $^{\circ}$), and other acetylenes containing both alkyl and aryl groups are obtainable by the general methods described above for the preparation of acetylenes (p. 952). Their chemical properties depend chiefly on the reactivity of the acetylenic group and differ little from those of the purely aliphatic acetylenes.

Diphenyl Group

The members of this group are aryl-substituted benzenes, of which the simplest is diphenyl or phenylbenzene.

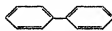

(I)

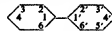

(II)

Diphenyl, $C_6H_5 \cdot C_6H_5$, is a hydrocarbon of m.p. 71 $^{\circ}$ and b.p. 254 $^{\circ}$, which is present in slight amount in coal tar, but is readily obtainable by synthetic methods. It is formed when benzene vapour is passed through red-hot tubes, but

is conveniently prepared by heating iodobenzene with copper powder (method of Ullmann).

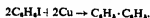

This synthetic method can be satisfactorily applied to the preparation of numerous symmetrical diphenyl derivatives; unsymmetrical diphenyl derivatives, on the other hand, must be prepared in other ways, e.g. by the action of alkyl chlorides or olefins on diphenyl in presence of aluminium chloride.

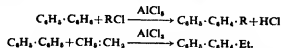

The structure of diphenyl is represented by formula (I), the different nuclear positions being distinguished by numbers as in formula (II).

Diphenyl shows a restricted tendency to additive reactions. On reduction with sodium and amyl alcohol it gives a tetrahydridiphenyl, $C_{12}H_{14}$ (b.p. 245°), which readily forms a dibromide, and on catalytic hydrogenation under pressure in presence of nickel it yields perhydridiphenyl, $C_{12}H_{18}$ (b.p. 235°). With ozone it forms a tetra-ozonide.

Diphenyl also yields substitution products. Each mono-substitution product can exist theoretically in three isomeric forms. Chlorine, bromine, the nitro-group, and the sulphonic group tend to enter most readily at the *p*-positions, with reference to the point of union of the two nuclei, but to some extent *o*-derivatives are also formed. Thus mono- and di-substitutions yield respectively *o*- and *p*-, and *o,p*- and *p,p*'-forms. Diphenyl can be oxidized by chromic acid in glacial acetic acid to benzoic acid.

As noted above, perhydridiphenyl can be obtained by the complete reduction of diphenyl; in addition it can be synthesized by the action of sodium on iodocyclohexane (method of Fittig). Phenylcyclohexane, $Ph-C_6H_{11}$, a semi-aromatic derivative of diphenyl, has not been obtained by reduction of diphenyl, but can be prepared by the action of chlorocyclohexane on benzene in presence of aluminium chloride.

Diphenylmethane Group

Diphenylmethane, benzylbenzene, $C_6H_5-CH_2-C_6H_5$, is a crystalline hydrocarbon of m.p. 26° and b.p. 262°, having the odour of oranges. It is formed by the action of benzyl chloride, or of methylene dichloride, on benzene in presence of aluminium chloride,

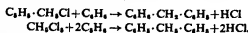

and also by the condensation of benzene with benzyl alcohol in presence of concentrated sulphuric acid.

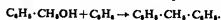

Both of these methods can be used for the preparation of nuclear-substituted diphenylmethanes if substituted benzenes are taken in place of benzene; other members of the group can be obtained by the reduction of suitable aromatic ketones with zinc dust, e.g. *p*-phenyl tolyl ketone gives with zinc dust *p*-phenyltolylmethane.

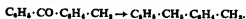

Homologues of diphenylmethane substituted in the methylene group are obtained by condensing aliphatic aldehydes or ketones with benzene,

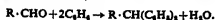

Diphenylmethane yields substitution products, but these are of little importance, since homogeneous substituted diphenylmethanes can usually be obtained directly by synthesis. The benzyl group attached to each nucleus exercises a strong *o,p*-directing influence so that on nitration diphenylmethane yields a mixture of *p,p'*- and *o,p*-dinitro-derivatives.

Naphthalene Group

Naphthalene, $C_{10}H_8$.



Occurrence. Naphthalene occurs in the 'middle oil' or 'carbolic oil' fraction of coal tar (b.p. 170–240°), and crystallizes out when the oil is cooled. The crystals are pressed, washed with caustic soda, and warmed with a small quantity of concentrated sulphuric acid; by this means the impurities are sulphonated and rendered soluble, the residual naphthalene being finally purified by distillation or sublimation.

Naphthalene is also found among the pyrolysis products of natural gas and in certain crude petroleum (p. 978).

Properties. Naphthalene crystallizes in large shining plates (m.p. 79°, b.p. 218°) which have a characteristic smell and are very volatile. Owing to its volatility naphthalene occurs extensively in crude coal gas and often to some extent in purified coal gas. It forms with picric acid a crystalline picrate, $C_{10}H_8 \cdot C_6H_3(NO_2)_3OH$, of m.p. 149°, when the two substances are dissolved together in alcohol; this substance has been used for the quantitative estimation of the hydrocarbon. Naphthalene is used extensively in the dyestuffs industry for the preparation of naphthols, naphthylamine, phthalic acid, and other *ye* intermediates.

Constitution. To naphthalene is ascribed a symmetrical formula composed of two benzene rings fused at the ortho-positions. The 8 hydrogen atoms of naphthalene are not all equivalent as regards their position in the molecule; to distinguish between the different hydrogen positions the carbon atoms of the ring are numbered or lettered in the way shown above.

Synthesis. Although naphthalene can be synthesized in numerous ways, these are only of theoretical interest, since the naphthalene of commerce is derived entirely from coal tar. The synthetic method of Baeyer and Perkin may, however, be mentioned as affording a formal proof of the fundamental ring structure of naphthalene. According to this, *o*-xylylene dibromide reacts with ethyl disodio-ethane-tetracarboxylate to give ethyl tetrahydronaphthalene tetracarboxylate,

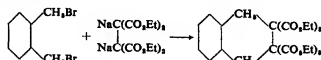

which on hydrolysis and elimination of carbon dioxide yields tetrahydronaphthalenedicarboxylic acid; from the latter naphthalene is obtained on distillation of its silver salt.

Properties. Naphthalene is a typically aromatic substance and closely resembles benzene in its properties, especially in its ability to give substitution products with the halogens, nitric acid and sulphuric acid. Nevertheless, the unsaturation of naphthalene is more clearly displayed

in its chemical properties than is that of benzene and its homologues, and naphthalene may be regarded as less saturated and more closely allied to olefinic hydrocarbons than benzene. This unsaturated character is revealed in the additive properties.

Substitution Reactions. (1) Naphthalene at its boiling-point reacts with chlorine and bromine to give α -chloronaphthalene (b.p. 263°) and α -bromonaphthalene (b.p. 279°) respectively. β -Halogeno-compounds can only be obtained indirectly.

(2) With concentrated nitric acid it gives nitro-derivatives, one, two, or more of the nuclear hydrogen atoms being replaced according to the temperature of reaction and the concentration of the acid. In this way α -nitronaphthalene (m.p. 61°, b.p. 304°), 1:5-dinitronaphthalene (m.p. 216°), and 1:8-dinitronaphthalene (m.p. 170°) are obtained.

(3) Naphthalene readily reacts with sulphuric acid to give the commercially important naphthalenesulphonic acids. When heated with anhydrous sulphuric acid at 80° it gives a mixture of α - and β -compounds, but when the reaction is carried out at 200° only the β -acid is formed, because at this temperature the α -acid undergoes isomerization to the β -acid. The two naphthalenesulphonic acids are hygroscopic, crystalline substances which resemble in their general character the benzenesulphonic acids. On heating naphthalene with anhydrous sulphuric acid at a high temperature disulphonic acids are formed.

Additive Reactions. (1) Naphthalene when treated with potassium chlorate and hydrochloric acid gives naphthalene dichloride, a yellow oil which begins to decompose into α -chloronaphthalene and hydrochloric acid at about 50°.

(2) With ozone it forms an explosive diazonide in which both the ozone molecules become attached to the same nucleus.

(3) On reduction with sodium and alcohol it gives Δ^1 -dihydronaphthalene, which reverts on heating (by dehydrogenation) to naphthalene, and isomerizes to Δ^1 -dihydronaphthalene on heating with sodium ethoxide at 140°.

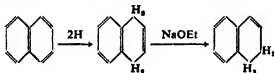

(4) On catalytic hydrogenation in presence of nickel at 15 atm. pressure it gives a 1:2:3:4-tetrahydro-derivative (tetralin, b.p. 206–8°), and on further hydrogenation at 12–15 atm. with a fresh nickel catalyst it gives a decahydro-compound (decalin, b.p. 189–91°). These hydrogenation products are extensively used as solvents, but, in addition, tetralin forms a useful source of β -substituted naphthalenes, since not only are the hydrogen atoms in the β -positions of its aromatic nucleus exclusively or extensively displaced by substituents, but the semi-aromatic products so formed readily undergo dehydrogenation to give the corresponding naphthalene derivatives.

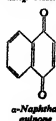

Oxidation. When naphthalene is boiled with a solution of chromic acid in glacial acetic acid, α -naphthaquinone is formed. This substance of pungent odour forms deep yellow needle-shaped crystals, m.p. 125°, which sublime readily and are distillable in steam.

Acenaphthene, a derivative of naphthalene, is found in coal tar. It is a crystalline solid, m.p. 95°, b.p. 277°, which may be prepared synthetically by treating α -bromoethyl-naphthalene, $C_{10}H_7 \cdot CH_2 \cdot CH_2Br$, with alcoholic potash.



Indene Group



Indene:

Occurrence. Indene occurs in that fraction of coal tar which boils between 176° and 182°. It can be isolated either by formation of its sodium derivative, which separates as a glassy mass when the crude hydrocarbon is heated with sodium at 140–50°, or by formation of its picrate. Appreciable amounts of indene also occur among the substances which are deposited during the purification of illuminating gas.

Preparation. Indene and its derivatives can be prepared synthetically by a number of methods of which only one need be mentioned here. *o*-Xylylene dibromide unites with disodium malonate to form hydriindenedicarboxylic ester, which on hydrolysis and elimination of carbon dioxide yields hydriindenecarboxylic acid.

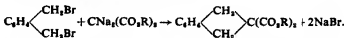

The latter on distillation of its barium salt yields indene.

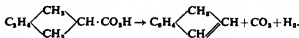

Properties. Indene resembles cyclopentadiene in that both of the hydrogen atoms of the methylene group are highly reactive. It forms, as noted above, a sodium derivative, $C_6H_4 \begin{array}{l} \text{CHNa} \\ \diagdown \\ \text{C} \\ \diagup \\ \text{CH} \end{array}$, when heated with sodium, and

gives alkyl derivatives when heated with alkyl halides in presence of alkali. In addition it unites with aldehydes such as benzaldehyde and cinnamic aldehyde to form condensation products.

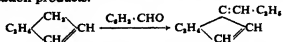

Indene forms additive products with hydrogen halides and with bromine. Thus with hydrogen bromide and with hydrogen iodide at 0° α -halogenohydrindenes are formed, but these compounds decompose on distillation, giving back indene (or polymerized indene) and hydrogen halide; also by the action of bromine indene dibromide is formed, but this decomposes on distillation to give γ -bromoindene. There is therefore a strong tendency on the part of substituted hydriindenes to revert to the more stable indene structure. On reduction with sodium and alcohol, or better, by catalytic hydrogenation, indene yields hydriindene.

Indene undergoes oxidation on exposure to the air and polymerizes readily (p. 959). It is oxidized by potassium dichromate and sulphuric acid to homophthalic acid and by nitric acid to phthalic acid.

The constitution of indene is highly mobile owing to the great ease with which the double bond of the five-membered ring shifts from the $\alpha\beta$ - to the $\beta\gamma$ -position.

Anthracene Group

Anthracene, $C_{14}H_{10}$.

Anthracene, a hydrocarbon which is extensively used in the preparation of dyestuffs, is prepared exclusively from the anthracene fraction of coal tar (b.p. 270° and upwards). It forms colourless lustrous plates, m.p. 216°, b.p. 351°, and yields with picric acid a ruby-red crystalline picrate, m.p. 138°. It displays characteristic aromatic properties and has been represented by various formulae, including (I), (II), and (III), which agree in the nature of the fundamental carbon skeleton, but differ in the detailed disposition of the double bonds. For most purposes, however, the constitution of anthracene is sufficiently represented by formula (IV), but since the 10 hydrogen atoms of the anthracene molecule are not all equivalent, it is necessary to distinguish between their positions by numbering or lettering the carbon atoms as shown in formula (IV).



Properties. On reduction with sodium and alcohol anthracene yields 9:10- (or *meso*-) dihydroanthracene, but on energetic reduction with phosphorus and hydriodic acid it gives both hexahydroanthracene, $C_{14}H_{16}$, and perhydroanthracene, $C_{14}H_{18}$. When reduced catalytically in presence of metallic catalysts, anthracene gives mixtures of 9:10-dihydro-, 1:2:3:4-tetrahydro-, and 1:2:3:4:5:6:7:8-octahydro-anthracene [32, 1932]. With chlorine in the cold anthracene yields anthracene dichloride, an additive compound, but at 100° substitution takes place with formation of monochloroanthracene and dichloroanthracene.

Anthracene unites additively with maleic anhydride to form the compound (V).

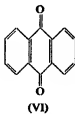
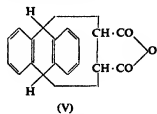

One of the most important derivatives of anthracene is anthraquinone (VI) which forms an intermediate in the preparation of numerous dyestuffs: this substance is obtained industrially by the oxidation of anthracene with sodium dichromate and sulphuric acid. Anthracene can also be oxidized to anthraquinone by means of nitric acid, but when the hydrocarbon is treated with a solution of nitric acid in glacial acetic acid containing acetic anhydride, substitution of the anthracene molecule takes place and 9-nitroanthracene is formed. Anthracenesulphonic acids are obtainable by direct sulphonation of the hydrocarbon.

Very numerous alkyl and aryl derivatives of anthracene are known.

Phenanthrene Group

Phenanthrene, $C_{14}H_{10}$. This hydrocarbon occurs in the anthracene oil of coal tar. It is a solid of no considerable industrial importance which crystallizes in white shining plates of m.p. 99° and b.p. 340°. It is isomeric with anthracene, and to it has been assigned the formula (I).

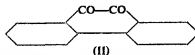
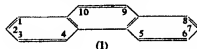

It yields both addition products and substitution products, the 9:10-positions being especially liable to attack by additive reagents. On oxidation with chromic acid in glacial acetic acid it yields phenanthraquinone (II), a substance which crystallizes in orange needles, m.p. 208°. Various alkyl- and aryl-derivatives of phenanthrene are known.

Retene, a dialkyl-derivative of phenanthrene possessing the formula (III), is formed by the dry distillation of the wood of conifers and therefore occurs in pine tar.

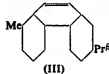

Fluorene Group

Fluorene, diphenylenemethane, $C_{15}H_{10}$, is a hydrocarbon of m.p. 113° and b.p. 295°, which is present in the fraction of coal tar boiling at 270–300°. It is formed when diphenylenemethane is passed through a red-hot tube.

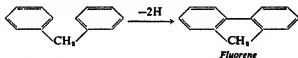

Fluorene is chiefly interesting in that like *cyclopentadiene* and *indene* its molecule contains a reactive methylene group. Owing to the situation of this group between two doubly bound carbon atoms, the hydrogen atoms are replaceable by metals and readily participate in condensation reactions. Thus fluorene forms a solid potassium

derivative, $\begin{matrix} C_6H_5 \\ | \\ C_6H_4 \\ | \\ C_6H_5 \end{matrix} CH_2$, with caustic potash (a fact which is taken advantage of in the isolation of the hydrocarbon from coal tar), and condenses with oxalic ester and with aldehydes; the products in the latter case being of the type $(C_6H_5)_2C:CHR$. Fluorene gives with picric acid a red picrate, m.p. 81°.

On oxidation with sodium dichromate in glacial acetic acid fluorene yields diphenylene ketone or fluorenone, $(C_6H_5)_2CO$, a yellow crystalline substance of m.p. 84° and b.p. 341°. The reverse process can be carried out by heating fluorenone with zinc dust or with hydriodic acid and red phosphorus at 160°.

Compounds analogous to fluorene are *retene-fluorene* (I), *chrysenefluorene* (II), *isophthalofluorene* (III), and *picefluoorene* (IV) (related to retene, chrysenes, 1:2-benzanthracene, and picecene respectively, q.v.).

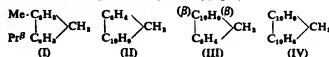

These compounds yield the corresponding ketones on oxidation and are regenerated from the ketones by reduction of the latter with zinc dust or hydriodic acid and phosphorus.

Triphenylmethane

Triphenylmethane, $(C_6H_5)_3CH$, is the parent hydrocarbon of an important series of dyestuffs. It is obtained in the following ways:

(1) By the action of benzylidene chloride on benzene or of chloroform on benzene in presence of aluminium chloride.

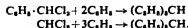

(2) By the decomposition of the magnesium compound of triphenylchloromethane with water. Triphenylchloromethane is readily obtained by the action of carbon tetrachloride on benzene in presence of aluminium chloride.

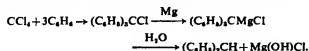

(3) By the action of phosphoric oxide or zinc chloride on benzhydryl and benzene, or upon benzaldehyde and benzene.

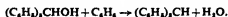

Triphenylmethane forms white crystals of m.p. 92° and b.p. 358°. It can readily be oxidized to triphenyl carbinol, and under the strong reducing action of hydriodic acid and red phosphorus breaks down into benzene and toluene.

Higher Polynuclear Hydrocarbons

In addition to the members of the foregoing groups numerous hydrocarbons containing from 4 to 9 condensed rings are known, including 2:3- and 1:2-benzanthracene (I) and (II), pyrene (III), chrysenes (IV), triphenylene (V), perylene (VI), 2:3:6:7-dibenzanthracene (VII), 2':3'-naphtha-2:3-phenanthrene (VIII), fluoranthene (IX), piceene (X), and coronene (XI). Of these perylene is of considerable

practical interest since it forms the basis of an important group of colouring matters.

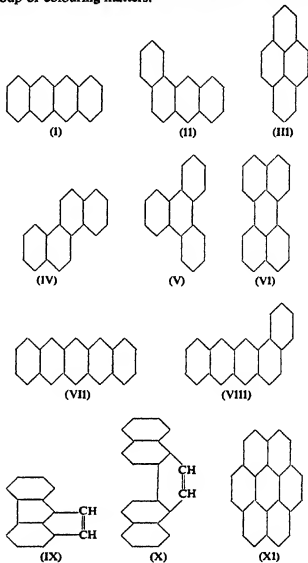

REFERENCES

- ALDER, K., STEIN, G., and FINZENHAGEN, H. *Ann.* **485**, 223 (1931).
- ALDER, K., STEIN, G., *et al.* *Ann.* **496**, 197 (1932); **504**, 216 (1933).
- _____, *Ann.* **496**, 204 (1932).
- AUWERS, K. *Ber.* **45**, 3078 (1912); *Ann.* **387**, 204 (1912). HARRIES, C. *Ibid.* 809.
- WILLTÄTTER, R., and HATT, H. *Ibid.* 1467.
- WILLTÄTTER, R., and WASER, E. *Ibid.* **44**, 3428 (1911).
- BACKER, H. J., and STRATING, J. *Rec. trav. chim.* **53**, 1113 (1934).
- BERGMANN, E. *J.C.S.* 1359 (1935).
- BERGMANN, E., TAUBADEL, H., and WEISS, H. *Ber.* **64**, 1493 (1931).
- BERGMANN, E., and WEISS, H. *Ann.*, **480**, 49, 59 (1930). SCHOEFFLE, C. S., and RYAN, J. D. *J.A.C.S.* **52**, 4021 (1930).
- BIRCH, C. F., and HAGUE, E. N. *Ind. Eng. Chem.* **26**, 1008 (1934).
- BODENDORF, K. *Arch. Pharm.* **271**, 1 (1933).
- BROOKS, B. T. *J.A.C.S.* **56**, 1998 (1934).
- BROOKS, B. T., and HUMPHREY, I. *J.A.C.S.* **40**, 825 (1918).
- BURWELL, A. W. *Ind. Eng. Chem.* **26**, 204 (1934).
- CF. RICE, F. O. *Ibid.* 260.
- CADMAN, W. H. *Ind. Eng. Chem.* **26**, 315 (1934).
- CAROTHERS, W. H., WILLIAMS, I., COLLINS, A. M., and KIRBY, J. E. *J.A.C.S.* **53**, 4203 (1931).
- CAROTHERS, W. H., KIRBY, J. E., and COLLINS, A. M. *Ibid.* **55**, 789 (1933).
- CHALLMERS, W. *J.A.C.S.* **56**, 912 (1934).
- Chemical Society Annual Reports*, **25**, 132 (1928); **26**, 121 (1929).
- COFFMAN, D. D., and CAROTHERS, W. H. *J.A.C.S.* **55**, 2040 (1933).
- COFFMAN, D. D., NIEUWLAND, J. A., and CAROTHERS, W. H. *Ibid.* 2048.
- CONANT, J. B., and PETERSEN, W. R. *J.A.C.S.* **54**, 628 (1932).
- CONANT, J. B., and TONGBERG, C. O. *J.A.C.S.* **52**, 1667 (1930).
- CUPPERY, M. E., and CAROTHERS, W. H. *J.A.C.S.* **56**, 1167 (1934).
- DEGROZ, A. *Bull. Soc. chim.* (3), **11**, 391 (1894); *Ann. Chim. Phys.* (vi), **2**, 209 (1895).
- DIELS, O., and ALDER, K. *Ann.* **460**, 98 (1928); **470**, 62 (1929); *Ber.* **62**, 2081 (1929).
- DUNSTAN, A. G. *Chem. and Ind.* **51**, 822 (1932).
- DYKSTRA, H. B. *J.A.C.S.* **56**, 1625 (1934).
- EIGENBERGER, E. *J. pr. Chem.* **127** (ii), 307 (1930); **129** (ii), 312 (1931); **131**, 289 (1931).
- BACKER, H. J., and STRATING, J. *Rec. trav. chim.* **53**, 543 (1934).
- ENKELAAR, C. J. *Rec. trav. chim.* **26**, 157 (1907); **27**, 422 (1908); **36**, 215 (1916); **45**, 337 (1926).
- VAN ROMBURGH. *Proc. C. Acad. Wet. Amsterdam*, **3**, 454 (1900).
- FARMER, E. H., and BACON. Unpublished work.
- FARMER, E. H., and WARREN, F. L. *J.C.S.* 897 (1929).
- FAVORSKI, A. *J. pr. Chem.* **37**, 382 (1888).
- FRANCIS, A. W. *Ind. Eng. Chem.* **20**, 277 (1928).
- FRIES, K., and SCHILLING, K. *Ber.* **65**, 1494 (1932).
- HAGUE, E. N., and WHEELER, R. V. *J.C.S.* 378 (1929).
- DUNSTAN, A. E., HAGUE, E. N., and WHEELER, R. V. *Ind. Eng. Chem.* **26**, 307 (1934).
- CF. FREY, K. *Ibid.* 198.
- HARRIES. *Ann.* **383**, 157 (1911); **395**, 211 (1913).

35. HENNING, G. F., KILLIAN, D. B., VAUGHN, T. H. and NIEUWLAND, J. A. *J.A.C.S.* **56**, 1130, 1384 (1934).
36. HENNING, G. F. and NIEUWLAND, J. A. *J.A.C.S.* **56**, 1802 (1934).
37. HOFMANN, F. and DAMA, P. *Schleischen Kohlenforsch. Kaiser Wilhelm Ges.* **2**, 97 (1925).
38. HOUTZ, R. C. and ADKINS, H. *J.A.C.S.* **55**, 1616 (1933).
39. HURD, C. D. *Ind. Eng. Chem.* **26**, 50 (1934).
40. IPATIEFF, V. N., PINES, H., and SCHAAD, R. E. *J.A.C.S.* **56**, 2696 (1934).
41. JACOBSON, R. A. and CAROTHERS, W. H. *J.A.C.S.* **55**, 1622 (1933).
42. ——— *J.A.C.S.* **55**, 4667 (1933).
43. KATO. *Bull. Inst. Phys. Chem. Res. (Tokyo)*, **10**, 343 (1931).
44. KEMULA, W., and MRAZEK, S. *Z. physik. Chem.* **23**, 358 (1933).
45. LIVINGSTON, R., and SCHLETT, G. H. *J. Phys. Chem.* **38**, 377 (1934).
46. LIND, S. C., and LIVINGSTON, R. *J.A.C.S.* **56**, 1550 (1934).
47. CI. TRUCL, F. *Coll. Czech. Chem. Comm.* **6**, 162 (1934).
48. KHARASCH, M. S., and HINCKLEY, J. A. *J.A.C.S.* **56**, 1212 (1934); **45**, KHARASCH, M. S., et al. *J.A.C.S.* **55**, 2468, 2521, 2531 (1933).
49. KISHNER, J. *Russ. Phys. Chem. Soc.* **42**, 1198 (1910); **43**, 1157 (1911).
47. ——— *J. Russ. Phys. Chem. Soc.* **44**, 849 (1912).
48. KLINE, G. M., and DRAKE, N. L. *Bur. Stand. J. Res.* **13**, 705 (1934).
49. KOMAREWSKY, V., JOHNSTONE, W., and YODER, P. *J.A.C.S.* **56**, 2705 (1934).
50. KUHN, R. and WAGNER-JAUREGG, T. *Ber.* **63b**, 2662 (1930).
51. LANDA, S., and MACHACEK, V. *Coll. Czech. Chem. Comm.* **5**, 1 (1933).
52. LAUGHLIN, K. C., NASH, C. W., and WHITMORE, E. C. *J.A.C.S.* **56**, 1395 (1934).
53. LEBEDEV, S. V. *J. Russ. Phys. Chem. Soc.* **43**, 820 (1911).
54. ——— *J. Russ. Phys. Chem. Soc.* **45**, 1249 (1913).
55. ——— *J. Russ. Phys. Chem. Soc.* **45**, 1357 (1913); *J.S.C.I.* **33**, 1224 (1914).
56. LEBEDEV, S. V., and KOBLJANSKY, G. G. *Ber.* **63b**, 103, 1432 (1930).
57. LEBEDEV, S. V., and MERESHKOVSKI, B. K. *J. Russ. Phys. Chem. Soc.* **45**, 1249 (1913).
58. LEBEDEV, S. V., and YAKUBCHIK, A. D. *J.C.S.* **832**, 2192 (1928).
59. LEVINE, A. A., and COLE, A. G. *J.A.C.S.* **54**, 338 (1932).
60. LUCAS, H. J., and EBERZ, W. F. *J.A.C.S.* **56**, 460, 1230 (1934).
61. MAREK, L. F., and FLEGG, R. K. *Ind. Eng. Chem.* **24**, 1428 (1932).
62. LUCAS, H. J., and YUN-PU LIU. *J.A.C.S.* **56**, 2138 (1934).
63. MCCUBBIN, R. J. *J.A.C.S.* **53**, 356 (1931).
44. ——— *Ind. Eng. Chem.* **26**, 94 (1934).
- See also CONANT, J. B., and WHELAND, G. W. *J.A.C.S.* **55**, 2499 (1933).
63. MCCUBBIN, R. J., and ADKINS, H. *J.A.C.S.* **52**, 2547 (1930).
64. MCCUBBIN, R. J., *ibid.* **53**, 356 (1931).
65. MICHAEL, A., and BRUNEL, R. F. *Amer. Chem. J.* **48**, 270 (1912).
65. MIDGLEY, T., HENNE, A. L., and SHEPARD, A. F. *J.A.C.S.* **54**, 381 (1932).
66. MIGNONAC, G., and DITZ, E. *Compt. rend.* **199**, 367 (1934).
67. MIGNONAC, G., and SAINT-AUNAY, R. V. *Compt. rend.* **189**, 106 (1929).
68. MIKLASCHEWSKY, S. *Ber.* **24**, Ref. 269 (1891).
69. NIEUWLAND, J. A., CALCOTT, W. S., DOWNING, F. B., and CARTER, A. S. *J.A.C.S.* **53**, 4197 (1931).
70. NORRIS, J. F. *J.C.S.* **245** (1926).
71. NORRIS, J. F., and JOUBERT, J. M. *J.A.C.S.* **49**, 873 (1927).
72. OSTROMBLESKI, I. *J. Russ. Phys. Chem. Soc.* **47**, 1911, 1928 (1915); *F.P.* **475**, 565 (1914).
73. PLATONOV, M. S., PLAKIDINA, V. A., and BELTISTOV, K. K. *J. Gen. Chem. Russ.* **4**, 421 (1934).
74. POWER, F. B., and KLEBER, C. *Pharm. Rundschau*, **13**, 60 (1895).
75. RUCZICKA, L., and STOLL, M. *Helv. Chim. Acta*, **7**, 272 (1924).
75. REICHERT, J. A., and NIEUWLAND, J. A. *J.A.C.S.* **45**, 2555 (1923); **50**, 2564 (1928).
76. RICE, F. O. *Ind. Eng. Chem.* **26**, 259 (1934).
77. ——— *J.A.C.S.* **53**, 1959 (1931); **54**, 3529 (1932); **55**, 3035 (1933); *Ind. Eng. Chem.* **26**, 259 (1934).
78. RICE, F. O., and DOOLEY, M. N. *J.A.C.S.* **55**, 4245 (1933).
79. CY. FREY, K. *Ind. Eng. Chem.* **26**, 198 (1934).
78. RUNGE, F., and MUELLER-CUNRADI, M. *Chem. Abs.* **27**, 4253 (1933).
- GILLET. *Bull. soc. chim. Belg.* **29**, 192 (1920).
- HURD, C. D. *Ind. Eng. Chem.* **26**, 51 (1934).
- HURD, C. D., and GOLDSBY, *J.A.C.S.* **56**, 1812 (1934).
79. RUCZICKA, L., et al. *Helv. Chim. Acta*, **9**, 249, 339 (1926); **11**, 496 et seq. (1928).
80. SCHULTZ, G. R. *J.A.C.S.* **56**, 1552 (1934).
81. SEMENOFF, A. *Chemical Kinetics and Chain Reactions*. Oxford Univ. Press.
82. STAUDINGER, H. *Ber.* **58**, 1088 (1925).
83. STAUDINGER, H., ASHDOWN, A. A., BRUSON, H. A., and WEHRLI, S. *Helv. Chim. Acta*, **8**, 934 (1929).
84. STAUDINGER, H., BRUNNER, M., FREY, K., GARBSCH, P., SIGNER, R., and WEHRLI, S. *Ber.* **62b**, 241 (1929).
85. STAUDINGER, H., ASANO, M., BONDY, H. F., and SIGNER, R. *Ibid.* **61b**, 2575 (1928).
- STAUDINGER, H., and BONDY, H. F. *Ann.* **468**, 1 (1929).
85. STORCH, H. H. *Ind. Eng. Chem.* **26**, 60 (1934).
86. STRAUS, F. and EHRENSTEIN, M. *Ann.* **442**, 93 (1925).
87. USPENSKI, A. E. *J. Russ. Phys. Chem. Soc.* **51**, 245 (1920).
88. WAGNER-JAUREGG, T. *Ann.* **496**, 52 (1932).
89. WHEELER, R. W., and WOOD, W. L. *J.C.S.* **1819** (1930).
90. WHITBY, G. S. *Trans. Inst. Rubber Ind.* **5**, 184 (1929).
91. WHITBY, G. S., and GALLAY, W. *Canad. J. Res.* **6**, 284 (1932).
91. WHITBY, C. S., and CROZIER, R. N. *Canad. J. Res.* **6**, 203 (1932).
92. ——— *Canad. J. Res.* **6**, 203 (1932).
- BRUSON, A., SERRELL, L. B., and CALVERT, W. C. *Ind. Eng. Chem.* **19**, 1033 (1927).
93. WHITBY, G. S., and GALLAY, W. *Canad. J. Res.* **6**, 280 (1932).
94. WHITBY, G. S., and KATZ, M. *Canad. J. Res.* **34**, 344 (1931).
95. ——— *J.A.C.S.* **50**, 1160 (1928); *Canad. J. Res.* **4**, 344 (1931).
- BERGMANN, E., and TAUBADEL, H. *Ber.* **65b**, 463 (1932).
96. WHITMORE, F. C. *J.A.C.S.* **54**, 3274 (1932).
97. ——— *J.A.C.S.* **54**, 3278 (1932) (cf. footnote).
98. ——— *Ind. Eng. Chem.* **26**, 94 (1934).
99. WHITMORE, F. C., and LAUGHLIN, K. C. *J.A.C.S.* **54**, 4011 (1932).
- WHITMORE, F. C., and EVERS, W. L. *Ibid.* **55**, 812 (1933).
- WHITMORE, F. C., and CHURCH, J. M. *Ibid.* **1119**.
100. WIEZEVICH, P. J., and FROLICH, P. K. *Ind. Eng. Chem.* **26**, 267 (1934).
101. ZELINSKI, N. D., and USPENSKI, A. E. *Ber.* **46**, 1466 (1913).
- USPENSKI, A. E. *J. Russ. Phys. Chem. Soc.* **51**, 257 (1920).
102. ZELINSKI, N. D., and KASANSKY, B. *Ber.* **60**, 1098 (1927).
103. ZELINSKI, N. D., and OUCHAKOFF, M. *Bull. soc. chim. (iv)*, **35**, 484 (1924).
104. ZELINSKI, N. D., and SCHUIKIN, N. *Ber.* **62**, 2180 (1929).
105. ZIEGLER, K., and BAIH, K. *Ber.* **61**, 253 (1928).
- ZIEGLER, K., and KLEINER, H. *Ann.* **473**, 57 (1929).
- ZIEGLER, K., JAKOB, L., WOLLTHAN, H., and WENZ, H. *Ann.* **511**, 45, 64 (1934).
106. ZIEGLER, K., GRABBE, H., and ULRICH, F. *Ber.* **57b**, 1983 (1924).

THE CHEMICAL CHARACTER OF PETROLEUMS AND PETROLEUM PRODUCTS

By BENJAMIN T. BROOKS, Ph.D., M. Inst. P.T.
Consulting Chemical Engineer, New York

The chemistry of the hydrocarbons, the composition of cracked gasolines, naphthenic acids, nitrogen compounds, and sulphur derivatives, have all been discussed in other special articles.

The majority of petroleum has never been examined chemically. Careful chemical investigations, however, have been carried out on a few petroleum. The statement commonly made in many of the older textbooks of organic chemistry, that Russian petroleum consists of naphthenes or 'hydroaromatic' hydrocarbons and 'American' or Pennsylvania petroleum consists of paraffins, is grossly inaccurate. The reader is referred to the several articles on the characteristics of Mid-Continent, Gulf Coast, and California petroleum, as well as those of other countries, to see how widely petroleum of the principal producing countries vary.

Very few examinations of gasolines for the relative percentages of paraffins, naphthenes, and benzenes have been made. Some attempts have been made to determine the anti-knock value of gasolines from such analytical data, but the analyses are much more laborious and the interpretations of the results much more uncertain than direct determinations of anti-knock value in standard types of testing engines. A number of analyses, by hydrocarbon types, of a number of straight-run gasolines from American crude oils have been published by Egloff, Bollman, and Levinson [27, 1931]. The analytical methods used were not described, but the results indicate qualitatively the wide variation in composition. Figures are also given for per cent. unsaturates, but in view of the omission of experimental methods and definitely proven absence of olefines in such careful work as that of the Bureau of Standards on Ponca Oklahoma distillates and the negative results obtained by Tausz [73, 1919] by the alcoholic mercuric acetate method on vacuum distillates of Java, Baku, and Roumanian oils, olefinic unsaturates are certainly not to be considered as normal constituents of straight-run gasolines. (In a refinery product there is always the possibility of gasoline recovered from coking stills or other cracking operations being included.)

TABLE I
Hydrocarbon Types in some American Straight-run Gasolines

Source	Naphthenes	Aromatics	Paraffins
Pennsylvania	13.0	6.9	77.9
"	1.2	4.2	92.3
"	23.4	0.0	75.3
"	11.7	4.9	80.5
Oklahoma, Cushing	23.7	4.9	69.8
"	17.9	3.6	74.8
" Seminole	23.0	4.5	69.1
Kentucky	23.1	2.8	68.3
California	34.9	2.8	57.2
"	41.2	0.8	55.7
Kansas	20.3	0.4	76.6
Texas, Refugio	23.1	8.7	66.0
" Van Zandt	0.0	2.9	95.4
Michigan, Mt. Pleasant	7.4	4.5	85.2

It is very questionable whether the intensive investigation of the identity and chemical constitution of the individual hydrocarbons in petroleum distillates is worth the effort of necessarily well-trained organic chemists, beyond the point where individual hydrocarbons can be separated readily in quantity. In many cases the productive life in many fields would virtually be over and the particular crude oil would perhaps no longer be available by the time a careful chemical investigation could be completed. Many of the chemical investigations reported in the literature are entirely without accurate information as to the source of the crude oil. It is not uncommon that a single small field may produce three or four quite different oils from different depths and different geological horizons. Thus, to say that certain constituents were found in a 'Texas' or 'California' oil is of little value.

Chemical investigation of the lighter petroleum distillates, including gasolines and kerosines, may be grouped about as follows:

(1) The isolation and identification of certain constituent hydrocarbons.

(2) The study and utilization of substantially pure hydrocarbons separated from straight-run or cracked products. So far this has been mainly limited to the butanes and pentanes of straight-run products, and ethylene and propylene among the cracked products. Improvements in the art of fractional distillation indicate that the normal paraffins up to nonane, and possibly decane, can be isolated in a fair state of purity, industrially, if desired.

(3) The separation of groups, types, or close fractions of hydrocarbons and their study and industrial utilization. Thus aromatics can be extracted and purified, as a group, by liquid sulphur dioxide; paraffin waxes are readily separated as a group and are industrially utilized to manufacture chemical products in cases where chemical *individuals* are not required. The C_4 fraction of highly cracked hydrocarbon mixtures cannot practically be separated by distillation alone. Such a fraction contains the following constituents:

TABLE II
Hydrocarbons in C_4 Fraction of Cracked Products

Hydrocarbon	Boiling-point, °C.
Isobutane	-12.2
Isobutene	-6.8
n-Butene-1	-5.0
Butadiene	-2.6
n-Butane	-0.3
Butene-2, trans.	+0.96
Butene-2, cis.	+3.73

However, by chemical means, from a close-cut C_4 fraction the isobutene can be selectively removed to form *tert*.-butyl alcohol, regenerated to pure isobutene or polymerized to di-isobutene or to the rubber-like polymer 'Vistanex'. The butadiene can be selectively removed by cuprous chloride and regenerated as such, or selectively reacted with maleic anhydride by the Diels-Alder reaction, and all three n-

butenes may be hydrated to form solely butanol-2, leaving only the saturated butanes.

In general, the hydrocarbons in petroleum are grouped as paraffins, naphthenes, and aromatic or benzenoid hydrocarbons. The paraffins are usually found in the largest proportions in the lower boiling or light gasoline fractions, the per cent. of paraffins decreasing in the higher boiling fractions. Benzenes have been found in all petroleum which have been carefully examined, though the per cent. of benzene, toluene, and xylenes in the light fractions of highly paraffinic crudes is very small. The higher-boiling alkylated benzenes are generally more abundant than benzene and toluene, and Birch and Norris [6, 1926] state that mesitylene and pseudocumene usually occur in the largest proportions, as compared with other benzenoid hydrocarbons. Kewley [40, 1921] states that the Miri Borneo oil yields benzene containing 80% naphthenes, 15% paraffins, and 5% aromatics, and that the Koeti Borneo oil yields a benzene containing 40% aromatics. The latter oil was used in England during the World War to produce toluene on a large scale by fractional distillation.

In 1929 Sachanen and Wirabianz [66, 1929] summarized their studies on the types of hydrocarbons found in several petroleum, as shown in the following tables. The methods for determining these groups are not accurate, but their results will serve, at least, qualitatively to indicate the composition of a few petroleum.

TABLE III

Average Composition of Typical Petroleum

Type of crude	Wax %	Asphalt %	Composition of 250-300° C. fraction		
			Paraffins	Naphthenes	Benzenes
Light paraffinic	1.5-10	0-6	46-61	22-32	12-25
Paraffin-naphthene	1-6	0-6	42-53	38-9	16-20
Naphthenic	traces	0-6	15-26	61-76	8-13
Benzenoid	0-0.5	0-20	0-8	57-78	20-35

The composition of the light fractions distilling from 60° to 300° C. of five petroleum is given in Table IV.

TABLE IV

Hydrocarbon Group Composition of 60-300° C. Fractions

Fraction b.p. ° C.	Bibi-Eibat		Mexico, Texas		Tonkana, Okla.		Davenport, Okla.		Huntington Beach, Cal.						
	Benzenes	Paraffins	Benzenes	Paraffins	Benzenes	Paraffins	Benzenes	Paraffins	Benzenes	Paraffins					
60-95	3	40	57	29	17	54	6	26	68	5	21	74	4	31	65
95-122	3	52	45	21	22	57	8	34	58	7	28	65	6	48	46
123-50	7	66	27	19	23	58	12	43	45	12	33	55	11	33	55
150-200	12	69	19	16	21	63	20	41	39	16	29	55	17	61	22
200-50	22	51	27	12	20	68	22	34	44	17	31	52	23	45	30
300-300	30	41	29	12	29	59	25	29	46	17	32	51	29	40	31

The large number of hydrocarbons present in petroleum and the difficulty of separating individual hydrocarbons of more than six carbon atoms from the complex mixtures, has been one of the factors which has inhibited the utilization of petroleum hydrocarbons as raw materials for chemical synthesis.

Composition of Low-boiling Petroleum Distillates.

The composition of the natural gasoline recovered from gas associated with the light paraffinic Pennsylvania oil has

been found by Anderson and Erskine [1, 1934] to be approximately as follows:

TABLE V
Pennsylvania Natural Gasoline

Hydrocarbon	% by volume
Propane and butanes	20
Isopentane	13
Normal pentane	17
Isohexane	9
Normal hexane	15
Isoheptane	8
Normal heptane	12
Octane	4
Residue	2

Erskine [29, 1926] later reported small proportions of benzene, toluene, and meta-xylene in Pennsylvania natural gasoline. Natural gasoline varies in character according to the nature of the petroleum with which the gas is associated. A natural gasoline separated from the gas in the Grozny field apparently contains a substantial proportion of cyclohexane [37, 1933], and Coates [20, 1922] reported a hydrocarbon of naphthenic character, distilling at 215-17° C., in the natural gasoline recovered in the Terrebonne Louisiana field.

In view of the fact that the propane, butanes, *n*-pentane, and isopentane can readily be separated on a large scale by efficient fractionation, all of these hydrocarbons can be considered to be available in very large quantities for chemical synthesis. Although relatively small quantities of *n*-pentane and isobutane are utilized for chemical synthesis, the quantities of propane and butane which are available are so great that their utilization mainly for the production of so-called polymer gasoline is the only use so far developed which is commensurate with the large supply.

The difficulty of isolating pure hydrocarbons of more than six carbon atoms from petroleum is well indicated by the work of Brown and Carr [10, 1926], and the investigations of C. W. Washburne and his associates in the United States Bureau of Standards on the composition of lighter distillates of a typical Mid-Continent petroleum. Brown and Carr fractionated 135 gallons of gasoline derived from the highly paraffinic Cabin Creek, W. Va., petroleum.

TABLE VI

Hydrocarbons Isolated from 135 Gallons of Cabin Creek Gasoline

Hydrocarbon	Quantity separated, c.c.	B.p., ° C.
Isopentane	200	30.5-30.6
<i>n</i> -Pentane	250	36.2-36.3
Isohexane	300	61.1-61.2
<i>n</i> -Hexane	1,000	68.9-69.0
<i>n</i> -Heptane	2,000	98.6-98.7
Iso-octane	2,500	117.9-118.1
Octane	1,100	124.3-124.5
<i>n</i> -Nonane	600	150.2-150.9

The work of the Bureau of Standards group on the composition of the lighter distillates from the South Ponca, Oklahoma, field, is evidently the most painstaking investigation of the kind ever undertaken. The work was done by C. W. Washburne, R. T. Leslie, J. D. White, F. W. Rose, S. T. Schickantz, J. H. Bruun, M. M. Hicks-Bruun, and B. J. Mair, and the investigation extended over a period of years. In much of the older work in which the isolation of various hydrocarbons was claimed few physical

properties or criteria of purity were given. Washburne [77, 1930] recommends the determination of no less than four physical properties, refractive index, density, boiling-point, freezing-point, and the behaviour to halogens for identification of the hydrocarbons isolated.

In addition to fractional distillation these workers employed crystallization from liquid methane and equilibrium melting and centrifuging at low temperatures in many instances. Extraction by liquid sulphur dioxide at -35° to -50° C. and purification of the extract by petroleum ether at -40° C., as shown by Tausz and Stüber [74, 1919], was also used in the separation and purification of some of the benzenoid hydrocarbons. Bruun and Hicks-Bruun [11, 1931] state that the possibility of isolating pure hydrocarbons from petroleum, by fractional distillation alone, seems to depend entirely upon the nature of the crude oil used. If the oil contains cyclic hydrocarbons which form constant boiling mixtures with the paraffins, a complete separation cannot be obtained in this way. For example, methyl cyclopentane or benzene, if present, form constant boiling mixtures with the hexanes. Since cyclic hydrocarbons as a rule have higher densities and higher refractive indices than the aliphatic hydrocarbons, the presence of these ring compounds probably accounts for the fact that these physical constants are usually higher for the paraffins reported as isolated from petroleum than for the corresponding synthetic hydrocarbons. The application of physical constants to the determination of the composition of gasoline is discussed by Marder [55, 1935] and by Ward, Kurtz, and Fulweiler (this work).

Hexanes. All five isomeric hexanes have been reported as isolated from petroleum, but Bruun and Hicks-Bruun [13, 1931] conclude that the only hexane previously isolated in a demonstrably pure condition was normal hexane, separated by Young [82, 1898].

Cyclohexane. Shortly after cyclohexane had been synthesized by von Baeyer, Markownikoff [57, 1895] showed that fractions boiling close to 80° C., of Caucasian petroleum, consisted mainly of this hydrocarbon. It has also been isolated by Chavanne [17, 1922] and by Fortey [32, 1898]. Benzene was removed by nitration, and by systematic equilibrium melting of the fraction boiling at about 80° C., Bruun and Hicks-Bruun [11, 1931] obtained cyclohexane in a purity of about 99.96%.

Methyl Cyclopentane. This hydrocarbon is very difficult to separate from *n*-hexane, the two boiling at 72° C. and 69° C. respectively. The nitro derivative was reported by Markownikoff [58, 1899]. Chavanne [16, 1911] studied a Borneo petroleum and obtained evidence of the presence of methylcyclopentane by fractional distillation and plotting the densities and aniline points. Bruun and Hicks-Bruun [12, 1931] nitrated the fraction boiling at $68-78^{\circ}$ C. and by further fractionation and equilibrium melting in the presence of methanol isolated the hydrocarbon itself in a purity of 98.7%.

***n*-Decane.** The presence of *n*-decane in Appalachian petroleum was indicated by the early work of Mabery and Dunn [49, 1896] and others. The purification of normal paraffins by digesting with chlorosulphuric acid, originally suggested by Aschan [2, 1898] and recommended by Shepard and Henne [67, 1930], was used by Bruun and Hicks-Bruun [14, 1932].

Benzenoid Hydrocarbons.

There are many isolated examples of the identification of benzene and certain alkylated benzenes in petroleum.

But none of the earlier investigations were as comprehensive as the study of the Ponca, Oklahoma, oil carried out at the Bureau of Standards. Benzene and some of its derivatives have frequently been reported as having been identified. Jones and Wootton [38, 1907] examined the oil from the Koetei district of Borneo and reported the presence of *alpha*- and *beta*-methyl-naphthalenes, separated as picrates from the fraction boiling at $180-210^{\circ}$ C.

The very high proportions of benzenoid hydrocarbons reported as present in certain crude oils is undoubtedly due in many cases to very inaccurate methods of determination or to unwarranted conclusions from experimental results. Thus Edeleanu and Gané [26, 1910] reported that on treating with nitric-sulphuric acid mixture, Pennsylvania gas oil yielded 41%, and a Java gas oil 110% nitro products. Markownikoff [56, 1886] sulphonated the light distillate, including kerosine, of Balachany (Baku) oil, crystallized the calcium sulphonates, and regenerated the hydrocarbons from sulphonic acids by super-heated steam. No attempt was made, however, to determine the per cent. of aromatic hydrocarbons in the original distillate or fractions. Several alkylated naphthalenes were noted which were not identified. Coscig [21, 1935] separated *beta*-methyl-naphthalene as the picrate from the fraction boiling at $110-12^{\circ}$ C. (20 mm.) from Roumanian oil and estimated the fraction to contain 8 per cent. of this hydrocarbon.

Xylenes. The presence of xylenes in gasoline was first shown by de la Rue and Müller [23, 1856], and Mabery established the presence of *meta*- and *para*-xylenes in Ohio, Canadian, and California petroleum by making the nitro derivatives of the fractions boiling at $137-40^{\circ}$ C. The presence of *ortho*-xylene has been shown by oxidizing the xylene fraction to the three phthalic acids. White and Rose [78, 1932] isolated the three xylenes, from Ponca, Oklahoma, crude, by fractional distillation, extraction of the xylene fraction by liquid sulphur dioxide, and finally by fractional crystallization.

Ethyl Benzene. This hydrocarbon was separated from a gasoline fraction for the first time by White and Rose [79, 1933] in their study of Ponca, Oklahoma, oil.

Trimethyl Benzenes. Engler [28, 1885] separated the trinitro derivatives of mesitylene (1,3,5-trimethyl benzene) and pseudo-cumene (1,2,4-trimethyl benzene), and thus showed their presence in a wide variety of petroleum. Markownikoff [56, 1886] established the presence of pseudo-cumene in a Caucasian petroleum by purifying the sulphonic acid and converting it into the acid chloride and the amide. The presence of hemimellitene (1,2,3-trimethyl benzene) in gasoline was first shown by Mair and Schick-tanz [51, 1933] in their study of Ponca, Oklahoma, oil, by extracting the fractions with liquid sulphur oxide. The relative proportions of these three trimethyl benzenes in the crude oil was estimated to be as follows: pseudo-cumene 0.2%, mesitylene 0.02%, and hemimellitene 0.06%.

TABLE VII
Group Composition of the Fraction 55-145° C. of
Ponca, Oklahoma, Oil

Type	Number of hydrocarbons	Estimated %	Known hydrocarbons in this range
Paraffins . . .	23	60	41
Naphthenes . . .	18	30	37
Benzenes . . .	6	10	6
Bicyclic hydrocarbons	4

TABLE VIII

Hydrocarbons Isolated from Ponca, Oklahoma, Oil

Formula	Hydrocarbon	Estimated % in 15-145° C. fraction	Purity of best sample, mole %
CH ₄	Methane	not determined	..
C ₂ H ₆	Ethane	" "	..
C ₃ H ₈	Propane	" "	..
C ₄ H ₁₀	Butanes	" "	..
C ₅ H ₁₂	Pentanes	" "	..
C ₆ H ₁₄	2,3-Dimethyl butane	0.3	95
"	2-Methyl pentane	0.6	95
"	3-Methyl pentane	1.3	95
"	n-Hexane	3.6	98.3
C ₇ H ₁₆	2,2-Dimethyl pentane	0.2	94
"	2-Methyl hexane	1.8	99.9
"	3-Methyl hexane	1.4	..
"	n-Heptane	6.0	99.9
C ₈ H ₁₈	2,2,3,3-Tetramethyl butane	0.3	..
"	2,5-Dimethyl hexane	0.2	..
"	2,4-Dimethyl hexane	0.2	..
"	2,2,3-Trimethyl pentane	0.2	..
"	3,4-Dimethyl hexane	0.3	..
"	2-Methyl heptane	1.1	97
"	3-Methyl heptane	0.9	..
"	4-Methyl heptane	0.9	..
"	n-Octane	7.0	99.1
C ₉ H ₂₀	2,2,5-Trimethyl hexane	1.2	..
"	2,4-Dimethyl heptane	0.4	..
"	2,5-Dimethyl heptane	0.5	..
"	4-Methyl octane	0.9	..
"	2-Methyl octane	1.5	..
"	3-Methyl octane	1.5	..
C ₁₀ H ₂₂	n-Decane	4.2	99.9
C ₁₀ H ₂₂	Cyclopentane
C ₈ H ₁₆	Methyl cyclopentane	1.45	98.9
C ₈ H ₁₆	Cyclohexane	2.20	99.9
C ₈ H ₁₆	1,1-Dimethyl cyclopentane	0.30	95
"	1,2-Dimethyl cyclopentane	1.45	..
"	1,3-Dimethyl cyclopentane	1.45	98
"	Methyl cyclohexane	2.20	99.9
"	Ethyl cyclopentane	0.30	..
C ₇ H ₁₄	Cycloheptane	0.90	..
C ₈ H ₁₆	1,2,4-Trimethyl cyclopentane	0.70	..
"	1,3-Dimethyl cyclohexane	1.10	95
"	1,4-Dimethyl cyclohexane	0.70	..
"	1,2-Dimethyl cyclohexane	0.40	..
"	1-Methyl-2-Ethyl cyclopentane	0.50	..
"	n-Propyl cyclopentane	0.70	..
"	Ethyl cyclohexane	0.70	95
C ₁₁ H ₂₂	Nonanaphthene	0.65	99
"	1,3,5-Trimethyl cyclohexane	0.70	..
"	1,2,4-Trimethyl cyclohexane	0.70	..
	<i>Benzenes</i>		
C ₆ H ₆	Benzene	0.60	99.8
C ₇ H ₈	Toluene	2.20	..
C ₈ H ₁₀	Ethyl benzene	0.20	94
"	o-Xylene	0.95	99
"	m-Xylene	0.95	99.9
"	p-Xylene	0.30	99.9
	% in 145-30° C. fraction		
C ₈ H ₁₆	Mesitylene (1,3,5-Trimethyl benzene)	0.30	99.9
"	Pseudocumene (1,2,4-Trimethyl benzene)	3.0	99.9
"	Hemimellitene (1,2,3-Trimethyl benzene)	0.9	99.9

Mair and White [53, 1935] recommended the selective extraction of benzenes with silica gel, from petroleum distillates in which the aromatic hydrocarbons are present in proportions of less than 15%.

A summary of the hydrocarbons isolated or detected in

the lighter fractions of Ponca, Oklahoma, oil, a fairly typical Mid-Continent crude, is given in Tables VII-VIII.

The normal paraffins from hexane to dodecane, inclusive, were isolated in a very high degree of purity by Shepard, Henne, and Midgley [68, 1931], but the origin of the gasoline used was not stated. For the physical constants of the normal paraffins the values of the synthetic hydrocarbons as determined by Mair [50, 1932] are recommended.

The close fractional distillation of straight-run gasoline has been studied by Fenske, Quiggle, and Tonberg [30,

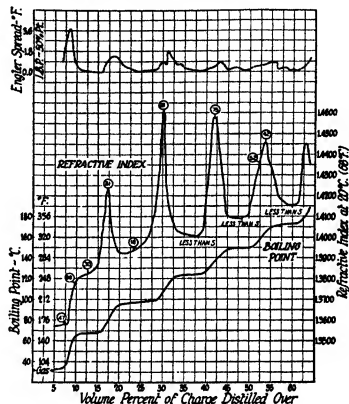

Fractionation of a Michigan Straight-run Gasoline
The numbers in circles are octane numbers obtained according to procedure 345.

1932] in highly efficient columns. Their results show the possibility of segregating close cuts consisting mainly of normal paraffins and thus greatly increasing the anti-knock value of the remainder. They were able to isolate in a relatively high state of purity 2-methyl pentane, n-heptane, methyl cyclohexane, and normal octane from a straight-run Pennsylvania gasoline. They were able to separate n-heptane and methyl cyclohexane, boiling 2.4° C. apart, and found no evidence of a constant boiling mixture of the two, as claimed by Young [83, 1922]. A comparison of Pennsylvania and Michigan straight-run gasolines showed a much greater proportion of normal paraffins in the latter.

TABLE IX
Comparison of Pennsylvania and Michigan Gasolines

Identifying constituents	Boiling range ° F.	Boiling spread ° F.	% of charge	
			Penn.	Mich.
Isomeric hexanes	143.2-149.9	6.7	3.35	0.82
n-Hexane	149.9-160.0	10.1	2.7	6.78
Isomeric heptanes	190.6-199.2	8.6	4.07	1.23
n-Heptane	199.2-213.4	14.2	9.41	10.05
Isomeric octanes	234.0-250.8	16.8	7.50	1.88
n-Octane	250.8-259.2	8.4	5.46	7.72

Kerosines.

Highly paraffinic crude petroleum has long been favoured for the manufacture of the kerosines of good burning qualities. The well-known Edeleanu method of extracting aromatic hydrocarbons by liquid sulphur dioxide, which was the first solvent extraction refining process to be operated industrially, was first applied to the refining of kerosine from Roumanian oil.

The kerosine fraction of Persian petroleum was investigated by Birch and Norris [6, 1926]. Oil recovered from the acid sludge was further purified by extraction with liquid sulphur dioxide and the extracted hydrocarbons fractionally distilled. The presence of toluene, *m*-xylene, *p*-xylene, *p*-ethyl toluene, mesitylene, pseudo-cumene, hemimellitene, a diethyl benzene, and ethyl xylene and naphthalene were identified. By direct extraction of the kerosine by liquid sulphur dioxide Birch and Norris were able to show the presence of naphthalene, *beta*-methyl naphthalene, dimethyl and trimethyl naphthalenes (the last two in the form of their picrates). Birch and Norris made use of bromine derivatives in identifying many of the benzene derivatives found, as, for example, tetrabromo-*p*-xylene, these being well-crystalline derivatives.

The light distillates of Borneo petroleum have been described by Kewley [39, 1921], who shows that in the Koetei field three distinct types of crude oil have been found, i.e. heavy asphaltic oil in the upper strata, light asphaltic oil at greater depth, and paraffinic oils containing wax at still greater depths. A similar relation has been shown to exist in the case of petroleum produced in the Gulf Coast fields in the United States, the lightest, most paraffinic oils being produced at the greatest depths. The relatively high content of aromatic hydrocarbons in the light distillates of the Koetei oils has long been known, having been investigated by Jones and Wootton [38, 1907], Tausz and Stüber [74, 1919], and by Chavanne and Simon [18, 1919]. Based on the work of the latter, Tizard and Marshall [75, 1921] developed a method for the estimation of aromatic hydrocarbons, in the light fractions, which is dependent upon the solubilities of paraffins, naphthenes, and aromatics in aniline, a method now widely employed. By this method Tizard and Marshall found the benzene fraction of Koetei oils to contain 26% paraffins, 35% naphthenes, and 39% aromatic hydrocarbons, the benzene being made from both the light asphaltic and wax-bearing crude oils. According to Kewley this benzene contains about 7% benzene, 14% toluene, 15% xylenes, and 4% higher boiling aromatics. The kerosine fraction is refined by liquid sulphur dioxide to remove the benzene and naphthalene derivatives.

Gas Oils.

Gas oil is one of the least accurately defined of all petroleum products. The term has generally been used for the intermediate fraction between kerosine and light spindle oils of viscosity about 100 Saybolt at 70° F. The term is still widely applied to cracking stocks which may include both lighter cuts (kerosine) and heavier oils (light lubricating oils).

The chemical character of gas oils is very little known. Investigations of such oils have usually been limited to determining their gas-making value or their value for cracking to motor fuel. (For the manufacture of gas from oil see 'Oil Gas', by L. J. Willien.)

On account of the poor yield of gas obtained from Borneo gas oil Ross and Leather [63, 1906] investigated it

and succeeded in identifying decahydronaphthalene. The high content of benzenes in the lighter distillates of certain Borneo oils has since been well established. In cracking for gasoline the recycled stock is more stable and yields less gasoline than the original uncracked oil. Its general behaviour in this respect resembles the highly aromatic Borneo gas oil, but recycled cracking stocks do not appear to have been investigated with respect to the character of the hydrocarbon components.

A study of fractions boiling in the range 250–300° C., in the distilling range of kerosine, is reported by Sachanen and Wirabianz [66, 1929]. The methods of analysis mainly relied upon in this work were sulphonation of the benzenoid hydrocarbons and determination of the aniline point of the residual oils. Much work has been done on the assay of gas oils to determine the relative proportions of aromatics, naphthenes, and paraffins present [76, 1934].

Lubricating Oils.

The chemical constitution of the hydrocarbons in lubricating oils has for long attracted the interest of organic chemists. It was early recognized that all of the paraffins C_nH_{2n-2} distilling in the range of lubricating oils are removable as wax leaving viscous oils substantially free from paraffins, although some confusion still exists due to calling lubricating oils from light wax-bearing crudes, such as that of Pennsylvania, 'paraffinic oils'. The early work of Mabery [45, 1897; 47, 1923; 48, 1926] clearly established that the readily distillable fractions of Mecca, Ohio, crude oil are more deficient in hydrogen than corresponds to the naphthene or C_nH_{2n} series. The fractions corresponding in molecular weight and boiling-point to hydrocarbons C_{14} to C_{25} show analyses corresponding to the empirical formula C_nH_{2n-4} . Higher boiling fractions, separated by solvents from the residuum, showed analyses indicating empirical formulae ranging from C_nH_{2n-4} to C_nH_{2n-30} . Similar heavy oils separated from oil from the Cabin Creek field showed analyses ranging from C_nH_{2n-8} to C_nH_{2n-11} ; heavy oil fractions from a Texas naphthenic oil showed analyses of C_nH_{2n-11} to C_nH_{2n-30} , and heavy viscous fractions from Baku petroleum showed compositions corresponding to C_nH_{2n-3} to C_nH_{2n-39} . Iodine numbers showed the absence of olefinic unsaturation. Mid-Continent oils freed from wax showed generally similar viscous fractions.

The hydrogen deficiency noted by Mabery is suggestive of the presence of alkyl derivatives of condensed ring or benzenoid hydrocarbons. Brooks and Humphrey [8, 1916] obtained evidence of the presence of benzene homologues in the high-boiling portions of Jennings and Oklahoma petroleum by identifying benzene, toluene, and xylenes in the light oils made by cracking; Jennings and Oklahoma reduced oils at 420° C., or at lower temperatures than those at which aromatics have been observed to be formed from aliphatic oils, and also by cracking by means of anhydrous aluminium chloride. Sachanen and Wirabianz [66, 1929] concluded from a study of the critical solution temperatures with aniline that the aromatic content of the fraction boiling at 450–500° C., of various crudes, varies from about 10 to 40%. This appears in accord with the fact that the losses on treating lubricating distillates with concentrated sulphuric acid and oleum in the manufacture of pharmaceutical white oils are commonly as much as 40%, although it seems evident that the reactions involved are not limited to sulphonation.

Considerable interest in the chemical structure of lubricating oils has been aroused by the development of solvent

extraction processes for resolving lubricating oils into oils of widely different viscosity-temperature characteristics. The less soluble components are less deficient in hydrogen, as noted by Mabery. It is evident that the viscosity characteristics of these high-molecular-weight oils is intimately related to their constitution. It is well known that the non-cyclic or C_nH_{2n-4} hydrocarbons, typified by the waxes, have relatively low viscosities and reduce the viscosity of oils in which they are dissolved, as shown by Bjerregard [7, 1922] and by Dean and Cooke [22, 1922]. The so-called paraffin oils or pharmaceutical white oils were regarded by Mabery as having very long side-chains attached to the naphthenic ring. These oils are much less viscous than the fraction from which they are made. It has long been known that too drastic refining by sulphuric acid greatly reduces the viscosity of the oil, as shown by Dunstan and Thole [25, 1917]. Wilson and Allibone [81, 1924] treated a lubricating oil from Burma crude with acetone-sulphur dioxide solution and found the following characteristics of the dissolved and undissolved oils:

	Insoluble	Soluble
Sp. gr. at 15°	0.890	1.020
Average formula	$C_{21}H_{40}$	$C_{21}H_{38}$
Series formula	C_nH_{2n-4}	C_nH_{2n-10}
Visc. at 60° C.	4.5	about 33
Visc. at 92.5° C./200° F.	1.93	1.9

Hydrogenated aromatic hydrocarbons or polycyclic naphthenes, without aliphatic side-chains, have low viscosities, as shown by Spilker [70, 1926] for hydrogenated anthracene (3 rings; chrysene, 4 rings) and pyrene. Bestuschew [5, 1931] believed that the lighter fractions contained alkyl derivatives of benzene and cyclohexane, naphthalene and decalynaphthalene, and the more viscous oil derivatives of anthracene and other polycyclic hydrocarbons and corresponding hydrogenated hydrocarbons. No very satisfactory evidence of these conclusions was advanced.

Hugel [36, 1932] noted that hydrogenated coal tars have considerably higher viscosities than the original tars and that hydrogenated dibenzyl naphthalene has a greater viscosity than the unhydrogenated product. He also noted that the temperature-viscosity curves of aromatic and hydro-aromatic derivatives decreased sharply with increasing temperature. From a study of a number of synthetic hydrocarbons Hugel drew the following conclusions:

1. Ring formation has a great effect in increasing the viscosity.
2. The branching chains in acyclic hydrocarbons has little or no effect on viscosity.
3. Unsaturation (olefinic) has very little effect on viscosity in acyclic hydrocarbons, although it may be a factor in cyclic compounds.
4. In general, a cyclic nucleus in a molecule is necessary if such factors as branching of the chain or unsaturation are to have any effect on viscosity, and in acyclic compounds viscosity is materially increased only by increasing the molecular weight.
5. Of two oils with the same viscosity at a given temperature, for example 50° C., the oil with the lower molecular weight is characterized by greater viscosity change with changes of temperature.

Unsaturated hydrocarbons, that is, having olefinic unsaturation, are undoubtedly present in lubricating oils although probably in minor proportions. Dunstan and Thole [25, 1917] state that a lubricating oil should contain

a certain proportion of unsaturated hydrocarbons and as large a proportion as is compatible with difficulties arising from oxidation and resinification. Brooks and Humphrey [9, 1918] noted that viscous polymers made by the action of sulphuric acid on various olefines are relatively inert to concentrated sulphuric acid even though still unsaturated. Sachanen and Wirabianz [66, 1929] estimate the proportion of unsaturated hydrocarbons in lubricating oils at 3-10%. Iodine numbers must be corrected for substitution and, unless supported by other evidence, should be accepted with caution.

Since the isolation of pure individual hydrocarbons from lubricating oils is almost impossible, Mikeška [59, 1936] has prepared a large number of synthetic hydrocarbons of different types and studied their viscosity characteristics, refractive indices and dispersions, aniline points, and Conradson carbon values. The facts brought out in this study, while giving no direct evidence as to the hydrocarbon constituents of lubricating oils, do establish many relationships which heretofore have been speculative or controversial. Mikeška states:

'The opinion held by many that aromatic derivatives on the one hand and olefinic on the other tend towards higher viscosities than the corresponding naphthenic and saturated compounds is rendered clearly untenable in view of the results . . . which show that (for at least the substances studied) naphthenics have higher viscosities than the corresponding derivatives with a double bond in the side chain. They also show that neither the saturation of a double bond nor the saturation of an aromatic ring has any marked effect on the viscosity index.

'The effect of the branching of the side chain is indeterminate. In some cases the viscosity is slightly increased; in other cases it is decreased to some extent, though the effect is never very great.

'The high viscosity indices of Pennsylvania and other paraffinic oils, which are assumed to have long side chains and are known to have a high ratio of paraffinic to cyclic atoms in their molecular composition, led to an early conviction that the length of the side chains is the controlling factor affecting the viscosity index of an oil. This was partially substantiated by Sullivan and Voorhees [72, 1931], who showed that the viscosity index of synthetic oils obtained by polymerization of olefins is dependent on the length of the olefinic molecule and that the longer the paraffinic chain of the original olefin, the higher the viscosity index of the resulting oil. These views were fully substantiated by the properties of the synthetic hydrocarbons prepared in this work. For instance, the viscosity index of octadecyl naphthalene is 150, whereas the viscosity indices of the three tri-*n*-hexylnaphthalenes are only about 100. Similarly, the viscosity index of docosamyl naphthalene, which has a chain of 22 carbon atoms, is 144, whereas the viscosity index of 1,1-naphthyl-*n*-butyl-octadecane with a chain of 18 carbon atoms is only 122, although they have the same number of paraffinic carbon atoms attached to the naphthalene ring.'

Dover and Helmers [24, 1935] synthesized tetra-*trans*-octadiene, $C_{24}H_{40}$, by the electrolysis of potassium oleate solution. The viscosity and other physical properties of this hydrocarbon were determined but no particular conclusions were drawn. It is of interest that this synthetic hydrocarbon, containing two double bonds, was easily hydrogenated and gave iodine numbers in fair agreement with the value required by two double bonds. This

supports the opinion, generally held, that the hydrogen deficiency indicated by the empirical formulae of lubricating oil fractions is not to be interpreted as signifying olefinic unsaturation.

A great deal of work has been done on the correlation of physical properties, including particularly viscosity and viscosity index, density, refractive index, with empirical composition. From data on the refractive indices and molecular weights of hydrocarbons of different types Kyropoulos [43, 1929] plotted separate curves for this correlation. He concluded that Pennsylvania and similar paraffinic oils are composed largely of isoparaffins. McCluer and Fenske [58 (a) 1932] desired to obtain an index involving viscosity and specific gravity, which would yield values numerically equal to the viscosity index. Accordingly, they devised the 'gravity index', obtained from the relation between the viscosity-gravity constant and the viscosity index, and showed that for various mineral lubricating oils their gravity indices had values practically equal to the viscosity indices. But they found also that this identity between gravity index and viscosity index no longer existed in the case of synthetic lubricating oils made by polymerization of olefine hydrocarbons. This circumstance points to some constitutional difference between these synthetic oils and the natural ones.

Rossini [64, 1935] has reported the results of the fractional distillation of the heavy viscous portions of a typical Mid-Continent petroleum. A so-called molecular still in which the pressure external to the distilling zone was maintained at 10^{-4} mm. of mercury was used. Rossini states that 'the information which has accumulated from the work of all the investigators in the field indicates that the hydrocarbon constituents of the better or more highly refined lubricating oils may include: (1) Naphthenes having one or two rings per molecule and long branched side chains, and possibly (2) branched-chain paraffins'.

Waxes, Paraffin Wax, Ceresin, Petrolatum, Rod Wax, and Ozokerites.

The reported wax contents of crude oils are usually inaccurate and may vary rather widely according to the method of determination used. The purpose of such determinations is to estimate the per cent. of crystalline wax of commercial quality which can be separated from the distillates by methods similar to those employed in the manufacture of commercial paraffin wax. This figure ordinarily does not include the finely crystalline so-called amorphous wax or ceresins, or the low-melting waxes, which are ordinarily removed in the sweating process. The average wax-bearing crude petroleum rarely contains more than 2 to 3% of ordinary crystalline wax. The low-melting paraffins not ordinarily recovered in filter pressing may average another 3 to 4%.

In many fields the wax content is greatest in oils occurring at greatest depths, as has been observed in Java [39, 1921], Baku [80, 1906], Galicia [69, 1912], and in the Gulf Coast fields of the United States [3, 1934]. However, some exceptions in which the opposite relationships exist have been noted.

According to Mabery [46, 1902] ordinary commercial paraffin wax appears to consist of the normal paraffins, mainly of the hydrocarbons $C_{23}H_{46}$ to $C_{29}H_{58}$. Later work by Carpenter [15, 1926] states that a typical Burma petroleum contains hydrocarbons from $C_{18}H_{38}$ to $C_{24}H_{50}$. Higher melting wax is obtained by exhaustive sweating of

the wax obtained from shale oil and by refining crude rod wax, deposited on the rods and casing of wells in many fields. The separation of such relatively high-melting wax is explained by the fact that the higher melting wax is less soluble than the lower melting paraffins. Paraffins melting as high as 76° C. and consisting mainly of the paraffin $C_{28}H_{58}$ have been reported from rod wax. Krafft [42, 1907] reported separation of paraffins melting from 85° to 93° C. from a hard wax separated from a Saxon lignite.

It has been shown by recent studies of the lighter fractions of a typical wax-bearing Mid-Continent oil (Ponca, Oklahoma) that large proportions of branched-chain paraffins accompany the normal paraffins. It has often been assumed that commercial paraffin waxes consisted essentially of normal paraffins. Recent investigations, however, show that, in general, petroleum contains substantial proportions of crystalline branched-chain paraffins. The subject has been a highly controversial one. The crystallizing behaviour of petroleum waxes and the effect of substances interfering with crystal growth has also been repeatedly investigated (see article by F. W. Padgett on 'The Crystallization of Paraffin Wax').

The paraffin wax separated from Scotch shale oil has been thoroughly investigated and conclusively shown to consist largely and probably entirely of normal paraffins. It should be pointed out, however, that this wax does not exist as such in the shale prior to destructive distillation, but is formed by decomposition of the complex organic material, the so-called kerogen, in the shale. It is therefore unwarranted to infer on the basis of these findings that paraffin waxes from petroleum are similarly constituted.

Paraffin wax from Scotch shale oil was investigated by Francis and his co-workers [33, 1922, 1926]. They separated the wax, by repeated fractional distillations in a high vacuum, into substantially pure substances which agreed very closely, in physical properties, with a series of synthetic normal paraffins. A study of the X-ray spectra of the hydrocarbons separated by Francis was made by Piper and his associates [61, 1925], who concluded that they were substantially pure individual normal paraffins. Further evidence as to the constitution of these waxes was furnished by Francis, Piper, and Malkin [34, 1930] by a study of the fatty acids formed from them by air oxidation. In a further study Piper and others showed that these normal paraffins exhibit two transition temperatures at which a change in crystalline form occurs, one very near the melting-point and one about five degrees below the melting-point. They also noted that the melting-points of mixtures of pure normal paraffins are not depressed, but fall on a straight line connecting the melting-points of pure individuals. This explains why the melting-point of commercial paraffin waxes cannot be much raised by separation or further purification.

Nametkin and Nifontava [60 (a), 1934] investigated a close-cut paraffin-wax fraction from Grozny oil solidifying at 52.8° C., molecular weight 338, and a commercial paraffin wax of American origin, solidifying at 50.1° C. and average molecular weight 322. By nitrating with dilute nitric acid the presence of a tertiary nitro derivative was shown. Both waxes were estimated to contain 25 to 30% of iso-paraffins.

It thus appears to be definitely established that the paraffin waxes from Scotch shale oil are normal paraffins. It seems to be equally well determined that waxes from petroleum, particularly those which have not been

subjected to much cracking, contain branched-chain hydrocarbons. Zaloziecki [55, 1888] believed that the iso-paraffins of high molecular weight yield well-crystalline normal paraffins on pyrolysis. In his opinion this partly accounts for the better crystallization of wax in distillates that are partly cracked. Waxes of high molecular weight, occurring in petroleum, and which separate first from crude oils as rod wax, are largely iso-paraffins. Thus Marcusson [54, 1914, 1915, 1917] showed that refined wax prepared from the crude wax separating in the wells of the Boryslaw field was practically identical in physical properties with two refined ozokerites or ceresins. Ceresins and well-crystalline paraffins of substantially the same melting-point have quite different molecular weights and differ considerably in other physical properties and chemical behaviour, as shown by the two examples described by Marcusson. The crystalline paraffin wax was a refined commercial wax made from a distillate, and the ceresin was refined from a Galician ozokerite.

	Paraffin wax	Ceresin
Melting-point in capillary	56.5-60.5°	57.5-60.1°
Solidification point	59.2	59.0
Sp. gr. at 15° C.	0.885	0.971
Sp. gr. at 60° C.	0.781	0.798
Viscosity ° Engler, at 70°	1.51	1.85
Average molecular weight	330	420
Behaviour with 33% oleum	brown discoloration	vigorous reaction
Behaviour with chloro-sulphonic acid	"	"

The identification of normal paraffins from petroleum waxes has been facilitated by the fact that a large number of synthetic normal paraffins are known. The recent synthesis of a number of branched-chain paraffins of large molecular weight by Suida and Planckh [71, 1933] is also very helpful. Solution of such a ceresin in lubricating oil and cooling yields a typical vaseline; ordinary wax crystallizes out in the normal way.

Sachanen [65, 1931] suggests that solid hydrocarbons derived from petroleum which can be removed in filter presses and sweated be called paraffin wax and that the solid hydrocarbons which do not possess these characteristics, regardless of their method of preparation, be called ceresins.

Although it is generally accepted that distillation of ceresins or oils containing them, if accompanied by cracking, yields well-crystalline wax, Sachanen showed that a ceresin of melting-point 74° C. and a molecular weight of 570 could be distilled in a very high vacuum at temperatures of 300° to 350° C. without appreciably changing its physical properties. According to Sachanen, all of the crystalline paraffin obtained in refinery practice consists of hydrocarbons of lower boiling-point than ceresins. He also believes that nearly all of the crystalline wax exists as such in the crude oils and is distilled substantially without decomposition with oil fractions of corresponding boiling-points. Untreated crude oils may contain paraffin wax and ceresin in varying proportions. Thus among the Russian crudes, the Grozny oil yields a relatively large amount of crystalline wax, which begins to come over with the light gas-oil fractions. Pennsylvania and most Mid-Continent oils apparently are of this type. Surakhany petroleum contains a large proportion of ceresins, found mainly in the very high-boiling fractions. The properties of ceresin fractions separated from petrolatum from heavy residuum of Surakhany petroleum are given in the following table:

TABLE X
Properties of Petroleum Ceresins
From Heavy Residuum

Melting-point, ° C.	85	80.5	71	63.5	57.5
Sp. gr. at 20° C.	0.940	0.932	0.932	0.928	0.925
Sp. gr. at 100° C.	0.785	0.785	0.782	0.787	0.785
Absolute visc. at 100° C.	0.101	0.0823	0.0786	0.794	0.0729
Nitrobenzene pt., ° C.	89.1	84.8	83.5	82.7	79.3
Refr. index, 99.5° C.	1.4368	1.4354	1.4369	1.4370	1.4375
Average mol. wt.	741	671	637	608	592
Formula	C ₁₅ H ₃₄	C ₁₄ H ₃₀	C ₁₃ H ₂₈	C ₁₂ H ₂₆	C ₁₁ H ₂₄

From Long Residuum

Melting-point, ° C.	74	65.5	61.5	56
Sp. gr. at 20° C.	0.931	0.932	0.929	0.925
Sp. gr. at 100° C.	0.787	0.784	0.788	0.786
Absolute visc. at 100° C.	0.0835	0.0793	0.0852	0.0642
Nitrobenzene pt., ° C.	81.8	80.5	82.2	75.1
Refr. index, 99.5° C.	1.4359	1.4412	1.4423	1.4359
Average mol. wt.	569	546	603	525

All of the ceresins described by Sachanen were high in boiling-point and associated with residual oils. The work of Ferris, Henderson, and Cowles [31, 1936] indicates that waxes of a wide range of melting-points, and distinguished from ordinary crystalline wax by higher boiling-points, a much finer crystal texture, toughness, a higher refractive index, and higher molecular weights, can be made by appropriate methods. The waxes described by them were made from slack wax and petrolatum stock by dissolving in ethylene dichloride and chilling. The properties of the waxes made in this way indicate that they are mainly branched-chain paraffins. This is consistent with the presence of branched-chain paraffins in the light distillates and in the heavy residual oils. Their work suggests that the lower boiling iso-paraffins, or soft ceresins, are ordinarily lost in the slack wax.

Some of the waxes made by Ferris, Henderson, and Cowles [31, 1929, 1933] have been examined by Clark and Smith [19, 1931]. By the X-ray diffraction method they obtained patterns consistent with normal paraffins for the high-melting waxes, but concluded that the low-melting material contained a large proportion of iso-paraffins. Low-melting waxes separated by recrystallization of wax from Boryslaw oil have been examined by Müller and Pilat [60, 1935], who believed them to contain cyclic nuclei, one fraction having the empirical formula C_nH_{2n-3-2}. Mair and Schickantz [52, 1936] have found that, like the low-melting waxes studied by Müller and Pilat, the low-melting waxes isolated by Ferris, Henderson, and Cowles show less hydrogen than is required for the paraffin or iso-paraffin series, and that certain fractions show 70-5% of the series C_nH_{2n}, or correspondingly smaller percentages of C_nH_{2n-3-2}.

A comprehensive study of paraffin waxes derived from Burma, Assam, Dutch East Indies, and American oils has been published by Carpenter [15, 1926]. Certain irregularities in the physical properties of the fractions obtained led Carpenter to suggest the presence of isomers of the normal paraffins. The highest melting-point wax obtained from clear Burma crude had a melting-point of 71.7° C., but he notes that waxes have been obtained from storage tanks, for Burma oil, melting as high as 84° to 85° C. A rod wax from Burma, purified through bauxite or Fuller's earth, is described as melting at 88° to 91° C., slightly yellow in colour, tough, and very finely crystalline.

Recrystallization from solvents gave a material melting at 96-5° C. Carpenter states that this high-melting wax is equivalent to 5 to 10 times its weight of stearin in imparting hardness, opacity, and freedom from mottling when mixed with ordinary waxes. Carpenter noted that in commercial waxes a transition point between two crystalline forms is evident 'some 10° to 15° C.' below the melting-point of wax. Piper (l.c.) noted transition points about 5° C. below the melting-point, but stated that very small traces of impurities lower the transition points markedly.

Reistle and Blade [62, 1932] have described rod waxes from the Bradford, Pennsylvania, the Panhandle, Texas, and Salt Creek, Wyoming, fields. They note a 'gummy' material in these waxes which is much less soluble than the crystalline waxes and which interferes with the crystal growth of the normal waxes, a well-known effect of ceresin waxes.

The range of composition and properties obtained by Sachanen from a typical crystalline wax from Grozny petroleum are given in the following table:

TABLE XI

Properties of Paraffin Fractions from Grozny Petroleum

Melting-pt., ° C.	32.8	40	47	54.3	60.3	66.3
Sp. gr. at 20° C.	0.872	0.879	0.906	0.914	0.919	0.923
Sp. gr. at 100° C.	0.736	0.740	0.747	0.752	0.759	0.763
Absolute vis. at 100° C.	0.0123	0.0145	0.0174	0.0203	0.0259	0.0322
Nitrobenzene pt., ° C.	44	47.6	52.4	56.2	61	65.2
Refractive index, 99.5° C.	1.4118	1.4153	1.4178	1.4218	1.4243	1.4266
Average s.p., ° C.	395	399	440	475	498	528
Average mol. wt.	284	310	334	395	427	468
Formula	C ₂₄ H ₅₀	C ₂₆ H ₅₄	C ₂₈ H ₅₈	C ₃₀ H ₆₂	C ₃₂ H ₆₆	C ₃₄ H ₇₀

Crystalline normal paraffin waxes of considerably higher melting-point than ordinary commercial wax from petroleum have recently been introduced. The new waxes are a product separated from the hydrocarbon mixture made by the hydrogenation of carbon monoxide according to the method of Fischer and Tropsch. Paraffins melting as high as 117° C. and molecular weights corresponding to C₁₁₆H₂₄₂ have been reported from this source [41, 1935].

Petrolatums.

The term petrolatum is used in the petroleum industry for the unctuous, salve-like residuum of clean paraffin-base oils such as light Pennsylvania petroleum, from which it was first manufactured; the term is also employed for the product, of similar properties, obtained by the centrifugal dewaxing of bright stocks and heavy, viscous distillates, particularly those stocked in vacuum. It is known as a commercial product under a wide variety of names and in varying degrees of purity. The most familiar names of the commercial products are vaseline, petroleum jelly, soft paraffin, paraffinum, cosmoline, graisse minérale (Fr.),

weichparaffin or paraffinsalbe (Ger.), vaselina (It.), &c. When highly refined and decolorized it is known as white petroleum jelly or petrolatum album.

In the United States much more crude petrolatum is produced than can be marketed for the customary uses, and most of it is disposed of by blending with cracking stocks.

The present discussion is limited to the chemical composition of petrolatums. In general, petrolatums are mixtures of solid paraffin hydrocarbons and viscous hydrocarbon oil. Petrolatums recovered by centrifugal dewaxing are stiffer and contain less oil than those obtained in other ways. In Europe some artificial petrolatums are manufactured by melting ceresins, rod wax, and the like with viscous, highly refined white oils. The latter sometimes develop granular character owing to the separation of crystal paraffin. Both natural and artificial petrolatums show a micro-crystalline character under the microscope in polarized light, as was shown by Gurwitsch [35, 1924]. The content of solid paraffins naturally varies with the method of production. Gurwitsch found 12.6% solid wax in a Russian natural vaseline and 9.6% in an American commercial vaseline. Others have reported 14 to 19% wax in Tschelken (Russian) petroleum, 12% in vaseline marketed by Chesebrough Co., and 15% in 'Wilbourine'.

The character of the oil in petrolatums is that of heavy lubricating oil and of course varies with the different crudes, the method of manufacture, and the degree of refining. For commercial and pharmaceutical uses petrolatum should be practically tasteless and odourless, light yellow or colourless, and only slightly fluorescent. The oil content should be sufficient to melt the mixture at about 36° to 40° C. Some descriptions have erroneously reported the oil as consisting of olefines. However, the temperatures reached in steam-reducing or ordinary vacuum distillation certainly result in some cracking, with the result that unrefined petrolatums may be expected to show a little olefinic unsaturation, which may be eliminated through refining. Susceptibility to oxidation by air is generally considered objectionable, particularly if discoloration or rancid odours develop. Reports of rendering pharmaceutical petrolatums bactericidal by exposure to light or ultra-violet light, in air, may possibly be explained by the formation of peroxides, in which case the complete elimination of olefinic unsaturation may not be desirable. Gurwitsch found an American commercial petrolatum to have an iodine number of 3.5, but believed this figure to represent only easily substituted hydrogen rather than olefinic unsaturation.

Gurwitsch, who demonstrated the presence of micro-crystalline wax in petrolatums, believes that no true colloidal jelly exists in such material. Zalozecki [84, 1888] believed that both crystalline and amorphous colloidal jelly are present in such mixtures. This question must be regarded as still not proven.

REFERENCES

- ANDERSON, R. P., and ERSKINE, A. M. *Ind. Eng. Chem.* 16, 263 (1924).
- ASCHAN, O. *Ber.* 31, 1801 (1898).
- BARTON, D. C. *Problems of Petroleum Geology*, Amer. Assoc. Petr. Geol., Tulsa, Okla. (1934).
- BELSTEIN, F., and WIEGAND, E. *Ber.* 16, 1547 (1883).
- BESTUSCHEW, M. *Erdöl u. Teer*, 7, 192 (1931).
- BERCH, S., and NORRIS, S. G. P. *J.C.S.*, 2545 (1926).
- BERREGARD, A. *Ind. Eng. Chem.* 14, 215 (1922).
- BROOKS, B. T., and HUMPHREY, I. W. *J.A.C.S.* 38, 393 (1916).
- . *J.A.C.S.* 40, 397 (1918).
- BROWN, G. G., and CARR, H. *Ind. Eng. Chem.* 18, 718 (1926).
- BRUUN, J. H., and HICKS-BRUUN, M. M. *Bur. Stand. J. Res.* 7, 607 (1931).
- . *Bur. Stand. J. Res.* 7, 799 (1931).
- . *Bur. Standards Research Papers* Nos. 239 and 311.
- . *Bur. Standards Research Paper* No. 438.
- CARPENTER, J. A. *J.I.P.T.* 12, 288 (1926).
- CHAVANNÉ, G. *Bull. Soc. Chim. Belg.* 31, 300 (1911).
- . *Bull. Soc. Chim. Belg.* 31, 361 (1922).
- CHAVANNÉ, G., and SIMON, L. J. *Comp. rend.* 169, 285 (1919).
- CLARK, G. A., and SMITH, H. A. *Ind. Eng. Chem.* 23, 697 (1931).

20. COATS, C. E., and TIMS, B. Y. *Ind. Eng. Chem.* **14**, 219 (1922).
21. COSCING, T. *Petr. Z.* **31**, 161 (5 Oct. 1935).
22. DEAN, E., and COOKE, M. B. *Ind. Eng. Chem.* **14**, 419 (1922).
23. DE LA RUE, W., and MÜLLER, H. *Proc. Roy. Soc.* **8**, 221 (1856).
24. DOVER, M. V., and HELMERS, C. J. *Ind. Eng. Chem.* **27**, 455 (1935).
25. DUNSTAN, A. E., and THOLE, F. B. *J.I.P.T.* **4**, 204 (1917).
26. EDELEANU, L., and GANÉ, Y. *Rev. Gen. Petrol.* **5**, 393 (1910).
27. EGOLOFF, G., BOLLMANN, H. T., and LEVINSON, B. L. *J. Phys. Chem.* **35**, 3492 (1931).
28. ENGLER, C. *Ber.* **18**, 2234 (1885).
29. ERSKINE, A. M. *Ind. Eng. Chem.* **18**, 722 (1926).
30. FENSKÉ, M. R., QUIGGLE, D., and TONGBERG, C. O. *Ind. Eng. Chem.* **24**, 408, 542, 814 (1932); **25**, 201 (1933).
31. FERRIS, S. W., HENDERSON, L. M., and COWLES, H. C. U.S. 1,937,518 (1933); *Ind. Eng. Chem.* **21**, 1090 (1929).
32. FORTEY, E. C. *J.C.S.* **73**, 932 (1898); **75**, 873 (1899).
33. FRANCIS, F., and co-workers. *J.C.S.* **121**, 2804 (1922); **129**, 1420 (1926).
34. FRANCIS, F., PIPER, S. H., and MALKIN, T. *Proc. Roy. Soc.* **128**, 229 (1930).
35. GURWITSCH, L. *Wissenschaftliche Grundlagen der Erdoelverarbeitung*, 2nd ed. (Springer, Berlin, 1924, p. 294).
36. HUGEL, G. *Chim. et Ind.*, **26**, 1282 (1932).
37. ISAEV, S., EGOROV, A. G., and GRIGORIEV, A. *Brit. Chem. Abs.*, **B**, 134 (1933).
38. JONES, H. O., and WOOTTON, H. A. *J.C.S.*, **91**, 1146 (1907).
39. KEWLEY, J. *J.I.P.T.* **7**, 209 (1921).
40. ——— *J.I.P.T.* **7**, 219 (1921).
41. KOCH, H., and IBING, G. *Brenn.-Chem.* **16**, 141 (1935).
42. KRÄFT, F. *Ber.* **40**, 4779 (1907).
43. KYROPOULOS, S. *Z. physik. chem.* **144** A, 22 (1929).
44. LESLIE, R. T., and WHITE, J. D. *Bur. Stand. J. Res.* **15**, 211 (1935).
45. MABERY, C. F. *Amer. Chem. J.* **19**, 419 (1897).
46. ——— *Proc. Amer. Acad.* **37**, 565 (1902).
47. ——— *Ind. Eng. Chem.* **15**, 1233 (1923).
48. ——— *J.A.C.S.* **48**, 2663 (1926); **49**, 1116 (1927).
49. MABERY, C. F., and DUNN, O. C. *Amer. Chem. J.* **18**, 230 (1896).
50. MAIR, B. J. *Bur. Stand. J. Res.* **9**, 47 (1932).
51. MAIR, B. J., and SCHICKTANZ, S. T. *Bur. Stand. J. Res.* **11**, 665 (1933).
52. ——— *Ind. Eng. Chem.* **28**, 1056 (1936).
53. MAIR, B. J., and WHITE, J. D. *Bur. Stand. J. Res.* **15**, 51 (1935).
54. MARCUSON, J. *Chem. Ztg.* **38**, 73 (1914); **39**, 613 (1915); *Mitt. kgl. Materialprüfungsamt*, **33**, 415 (1917).
55. MÄRDER, M. *Erdöl u. Teer*, **11**, 41 (1935).
56. MARKOWNIKOFF, W. *Ann.* **234**, 97 (1886).
57. ——— *Ber.* **28**, 577 (1895); **30**, 974 (1897).
58. ——— *Ann.* **307**, 343 (1899).
- 58a. McCLUER, W. B., and FENSKÉ, M. R. *Ind. Eng. Chem.* **24**, 1371 (1932).
59. MIRESKA, L. A. *Ind. Eng. Chem.* **28**, 970 (1936).
60. MÜLLER, J., and PILAT, S. *J.I.P.T.* **21**, 887 (1935).
- 60a. NAMETKIN, S. S., and NIFONTOVA, S. S. *Chem. Abs.* **28**, 3569 (1934).
61. PIPER, S. H., BROWN, D., and DYMENT, S. *J.C.S.* **127**, 2194 (1925).
62. REITHE, C. E., and BLADE, O. C. *U.S. Bur. Mines, Bull.* **384**, 125 (1932).
63. ROSS, R., and LEATHER, J. P. *Analyst*, **31**, 284 (1906).
64. ROSSINI, F. *Oil and Gas J.* **34**, no. 6, 41, 43, 45 (1935).
65. SACHANEN, A. N. *Nat. Petr. News*, May 1931.
66. SACHANEN, A. N., and WIRABIANZ, R. A. *Petr. Z.* **25**, 867 (1929); *Erdöl u. Teer*, **9**, 187 (1933).
67. SHEPARD, A. F., and HENNE, A. L. *Ind. Eng. Chem.* **22**, 356 (1930).
68. SHEPARD, A. F., HENNE, A. L., and MIDGELY, T. *J.A.C.S.* **53**, 1948 (1931).
69. SIEGFRIED, J. *Petr. Z.* **7**, 130 (1912).
70. SPILKER, A. J. *Z. angew. Chem.* **39**, 1138 (1926).
71. SUIDA, H., and PLANCKH, R. *Ber.* **66**, 1445 (1933).
72. SULLIVAN, F. W., JR., VOORHEES, V., NEELY, A. W., and SHANKLAND, R. V. *Ind. Eng. Chem.* **23**, 609 (1931).
73. TAUSZ, J. *Z. angew. chem.* **32**, 233 (1919).
74. TAUSZ, J., and STRÜBER, A. *Z. angew. chem.* **32** (1), 175, 361 (1919).
75. TIZARD, H. T., and MARSHALL, A. G. *J.S.C.I.* **40**, 20 T (1921).
76. VAN DIJK, J. A. *Chem. Abs.* **28**, 885 (1934).
77. WHITBURN, C. W. *Ind. Eng. Chem.* **22**, 985 (1930).
78. WHITE, J. D., and ROSE, F. W. *Bur. Stand. J. Res.* **9**, 711 (1932).
79. ——— *Bur. Stand. J. Res.* **10**, 639 (1933).
80. WIELZINSKI, M. *Chem. Ztg.* **30**, 106 (1906).
81. WILSON, W. J., and ALLIBONE, B. C. *J.I.P.T.* **11**, 186 (1924).
82. YOUNG, S. *J.C.S.* **73**, 1910 (1898).
83. ——— *Distillation Principles and Processes*, 52 (Macmillan, 1922).
84. ZALOZIECKI, R. *Z. angew. Chem.* **2**, 261, 318 (1888).

THE CHEMICAL COMPOSITION OF CRACKED GASOLINES

By JACQUE C. MORRELL, B.S., M.A., Ph.D. and GUSTAV EGLOFF, A.B., M.A., Ph.D.

Universal Oil Products Company

THE chemical composition of cracked gasoline is influenced by the type of crude oil and the fractions therefrom subjected to cracking and by the conditions of treatment, namely, the temperature, pressure, and reaction time.

Hydrocarbons in Cracked Distillates

Practically all of the work on the chemical composition of cracked gasolines has been directed to the determination of hydrocarbon groups rather than individual compounds. The determination of these groups depends entirely upon the analytical method employed, and a critical review of the various methods is therefore presented together with results which have been obtained by the application of these various methods in the analysis of cracked distillates.

Sulphur, Oxygen, and Nitrogen Compounds

In addition to hydrocarbons of the various groups, petroleum contains compounds of sulphur, oxygen, and nitrogen, and these are also found in the distillates resulting from the cracking of petroleum and its fractions.

Sulphur Compounds

Some work has been done on the pyrolysis of sulphur compounds, the distribution of sulphur in the various products of cracking, and the determination of sulphur compounds in cracked distillates.

Faragher, Morrell, and Comay [18, 1928] investigated the thermal decomposition of organic sulphur compounds, with the following conclusions: The thermal decomposition of mercaptans produces hydrogen sulphide and elementary sulphur. Hydrogen sulphide, mercaptans, and thiophene-like products are produced when sulphides are thermally decomposed. The disulphides produce hydrogen sulphide, elementary sulphur, sulphides, and thiophene-like derivatives. Thiophenes undergo no decomposition even at a temperature of 1600° F.

Egloff and Morrell [15, 1923] showed the distribution of sulphur in the cracking of a Mexican gas oil to be as follows:

TABLE I

	% Sulphur by weight	% Sulphur of total
Charging stock	2.19	100
Pressure distillate	1.40	23.05
Residuum	3.84	62.08
Coke	5.22	2.01
Gas	8.5	12.9

Faragher, Morrell, and Monroe [19, 1927] developed a systematic procedure for the quantitative determination of sulphur and sulphur derivatives in petroleum distillates as hydrogen sulphide, elementary sulphur, mercaptans, sulphides, disulphides, and different so-called 'residual' sulphur compounds comprising thiophenes and other types of sulphur compounds. Several untreated gasolines were analysed by this method, with the following results:

TABLE II
Analysis of Untreated Gasolines

Sulphur	Cracked gasoline		Straight-run gasoline Panhandle crude %
	Calif. (Mid- way) crude %	Smackover crude %	
Elementary	none	none	0.05
Mercaptan (titration)	0.02	0.02	0.04
Disulphide	0.11	0.03	none
Sulphide	0.02	none	none
Residual	0.95	0.15	none
Hydrogen sulphide	present	present	present

Morrell and Egloff [40, 1927] determined the sulphur content of about 30 different heavy oils from various fields, comprising crude oils, topped crudes, fuel oils, and distillate fractions comprising cracking stocks, to correlate the sulphur content in the charging stock with the percentage of sulphur in the cracked distillate and in the treated gasoline.

In a later paper [41, 1933] these same authors showed the distribution of sulphur in cracked distillates, both untreated and treated, and the effect of sulphuric acid concentration and temperature of treatment upon the removal of sulphur from the distillate.

Phenols.

The presence of phenols in cracked distillates has been noted by Brooks and Parker [9, 1924] and also by Catlin [10, 1926]. Catlin extracted cresylic acid from petroleum distillates and showed that ortho-, meta-, and para-cresols are present and may be recovered from the caustic-soda extract of cracked distillates by acidification. The presence of methylphenylcarbinol was also indicated.

Morrell and Egloff [42, 1928] show that lower boiling phenols are produced by the cracking of higher boiling phenols in addition to neutral oils and water. These lower boiling phenols will therefore be present in the gasoline fraction resulting from the cracking of the higher boiling phenols in charging stocks containing them.

Nitrogen Compounds

Very little of a definite nature is known about the nitrogen compounds in cracked gasoline.

Morrell and Egloff (2nd International Conference on Bituminous Coal, *Proc.* 2, 580, 613 (1928)) indicate that the nitrogen bases present in higher boiling hydrocarbons such as coal tars when cracked would produce lower boiling nitrogen bases which will be found in the gasoline fraction. This, no doubt, also applies to corresponding petroleum fractions.

Analytical Methods

The four groups of hydrocarbons of principal interest in connexion with the analysis of cracked distillates are the unsaturated, aromatic, naphthene, and paraffin hydrocarbons.

Determination of Olefines.

One of the most common methods used to determine olefines is halogenation. Modifications of the procedures used for fatty oils have been employed, but while they are indicative of olefine content, they have not proved quantitatively successful. The main difficulty is that substitution takes place concurrently with addition at the double bond, and even attempts to take into consideration the extent of substitution have not proved satisfactory.

Certain reagents have been employed in which apparently no substitution occurs, but with these reagents addition was found to be incomplete [23, 1895; 55, 1895]. The presence of diolefines complicates the problem, as many of them react with halogens as if they contained only one double bond. Furthermore, the results depend upon the ratio of the amounts of oil and the reagents used, and a constant result can be obtained only when this ratio is kept constant [43, 1925].

Good results may be obtained by the use of a bromide-bromate mixture [22, 1926; 43, 1925], since under these conditions very little bromine is present at any time and substitution is largely prevented.

Morrell and Levine [44, 1930] proposed a rapid procedure employing bromine titration for the determination of olefines in cracked hydrocarbon distillates. The errors involved in this determination were overcome, in part, by calculating the olefine concentration of an unknown oil from the ratio of its bromine titre to that of a standard solution containing a known concentration of known olefines.

At best, however, the results obtained by halogenation represent the 'concentration' of double bonds rather than of olefinic hydrocarbons. In such cases the olefine content may be calculated by determining the average molecular weight of the oil, and by assuming that the average molecular weight of the olefines is the same as that of the oil as a whole.

Other methods have been employed for the determination of olefines; as for example, the formolite method [46, 1904], which depends upon the formation of a resin when an oil containing olefines is refluxed with formaldehyde and a strong acid. This method is open to the objection that the resin formed does not correspond to all the olefines present and, furthermore, the reagent reacts with aromatic hydrocarbons.

Mercuric salts, particularly the acetates, react with olefines [65, 1921], and several methods of analysis have been devised for the determination of olefines based upon this reaction [36, 1923; 60, 1919-20]. A large excess of mercuric acetate [52, 1927] must be used to cause all of the olefines to react and refluxing is necessary [5, 1927]. Some of the unchanged oil is retained mechanically by the flocculent precipitate that forms.

Advantage has been taken of the heat of reaction of the olefines with sulphuric acid to determine the relationship between the percentage of olefines present and the quantity of heat evolved [11, 1926; 27, 1913; 32, 1892]. This is not an accurate method for the determination of olefines in cracked gasoline. Furthermore, strong sulphuric acid reacts with aromatic hydrocarbons and to some extent with naphthenes and paraffins. It also causes alkylation, polymerization, and various other reactions which will be referred to below. The problem is further complicated, since each olefine has its own heat of reaction with sulphuric acid.

Various solvents have been employed to separate olefine

and aromatic hydrocarbons from other hydrocarbons, and some difficulties are encountered in the application of these methods of analysis. The separation of the olefines and the aromatic hydrocarbons is usually incomplete, and the paraffin and naphthene hydrocarbons are dissolved to some extent. Some of the solvents which have been used are *liquid sulphur dioxide* [3, 1916-17; 13, 1914; 17, 1913; 35, 1918; 36, 1923]; a solution of *sulphur dioxide in acetone* and other ketones [28, 1922; 49, 1922; 50, 1913; 62, 1920]; *sulphoacetic acid* [30, 1925-7]; *dimethyl sulphate* [26, 1907, 1925; 63, 1906]; *selenium oxychloride* [31, 1921]; *methanol* [58, 1923; 13, 1914]; *acetic anhydride* [59, 1918]; *aniline* [5, 1927; 25, 1927; 28, 1922]; *nitrobenzene* [5, 1927]; *dimethylamine* [5, 1927; 25, 1927]; *ethyl tartrate*, *ethyl oxalate*, *acetoacetic ester*, *levulinic acid*, *phenylhydrazine*, and *furfural* [25, 1927]. In some cases fairly sharp separation may be made if the correct quantity of reagent is used and the percentage of olefine and aromatic hydrocarbons lies within certain limits.

Perbenzoic acid has been found to react with olefines and diolefines and other unsaturated compounds at low temperatures, and this reaction has been used as the basis of a method for the quantitative estimation of olefines [45, 1927; 37, 1921].

Sulphuric acid is perhaps the most widely used reagent for the determination of hydrocarbon groups. It reacts with olefines to give five principal types of products, namely, sulphuric esters, polymers, oxidation products [8, 1918; 9, 1924], and saturated hydrocarbons by reduction [32, 1892; 47, 1927; 51, 1895]. Alkylation also occurs to a considerable extent when aromatic hydrocarbons are present. The extent to which each of these reactions takes place is a function of the molecular weight and structure of the olefine and the concentration of the acid. Polymerization increases with increase in molecular weight, and up to a certain point increases with the concentration of the acid, the maximum polymerization taking place in the presence of approximately 91% acid [29, 1925]. The separation of olefines and aromatic hydrocarbons is complicated further because these hydrocarbons condense with the formation of alkyl derivatives of the aromatic hydrocarbons [4, 1926; 57, 1926]. However, approximate separations may be made by various concentrations of acid. Acid having the strength of 80% has been most generally proposed because it has very little action on the aromatic hydrocarbons. However, all of the olefines are not removed. Sulphuric acid stronger than 80% has been proposed but is open to the objection of reaction with aromatic hydrocarbons.

Determination of Aromatic and Naphthene Hydrocarbons.

Aromatic hydrocarbons may be determined by physical as well as by chemical methods. The physical measurements employed are density, refractive index, and critical solution temperatures in various organic liquids. In general, the aromatic hydrocarbons have a much higher density and refractive index than the other hydrocarbons. Also, they show an increase in the total volume when mixed with paraffin hydrocarbons, although this increase varies for the specific aromatic and paraffin hydrocarbons.

Various organic liquids have been found with which paraffin and naphthene hydrocarbons are not miscible at room temperature but in which the aromatic hydrocarbons dissolve readily. When aromatic hydrocarbons are dissolved in a mixture of paraffin and naphthenes the

temperature at which complete miscibility with the solvent occurs is lowered. The higher the concentration of the aromatic hydrocarbons the greater is the lowering of the solution temperature. The solvent most widely used for this test is aniline. Another solvent used is nitrobenzene. This method also furnishes a basis for the determination of naphthene hydrocarbons.

The chemical methods employed for the determination of aromatic hydrocarbons make use chiefly of sulphonation and nitration. Sulphuric acid of 98% strength has been used widely for sulphonation. Nitration is also a commonly used method for the determination of aromatic hydrocarbons wherein fuming nitric acid is employed and the nitrated products dissolved in a known volume of sulphuric acid. One of the best methods consists in the use of a nitration mixture of nitric and sulphuric acid so chosen that the nitro compounds concentrate in a separate layer, the volume of which is proportional to the concentration of aromatic hydrocarbons in the oil.

Widely Used Methods for Hydrocarbon Group Analysis of Gasolines.

None of the methods of analysis which have been developed are beyond criticism. All of them have limitations. Those most widely used are described below.

Egloff and Morrell [14, 1926] developed a method of determining the unsaturated, aromatic, naphthene, and paraffin hydrocarbons in cracked gasolines, and related the percentage composition of the four hydrocarbon groups to the anti-knock properties of motor fuels.

Unsaturated hydrocarbons were determined by distilling the motor fuel up to 210° C. and treating the distillate with two volumes of 80% sulphuric acid, which was stated to be without substantial effect on pure aromatic hydrocarbons. Correction was made for the polymers boiling above 210° C.

The overhead fraction to 210° C. obtained by redistillation of the 210° fraction on which the olefines were determined was treated with 2½ volumes of a nitration mixture consisting of 25% nitric acid, 58% sulphuric acid, and 17% of water (which was found to be the optimum mixture) to determine aromatics. This forms a 3-liquid layer system with unreacted oil at the top, nitro derivatives in the centre, and acid sludge on the bottom. The percentage of aromatic hydrocarbons was calculated from the volume of the middle layer.

To determine naphthenes the residual oil from the nitration treatment was examined for aniline point, assuming that paraffin hydrocarbons are completely miscible at 70° C. and that the aniline point is lowered 0.3° C. for each 1% of naphthenes present. The paraffins were estimated by difference.

Table III shows analyses of cracked gasolines from various stocks using this method:

TABLE III

Hydrocarbons	Braman, Tonkawa, Kansas topped crude	Kentucky fuel oil	Smack- over heavy crude	North Texas fuel oil	Last Soldier Wyoming crude
Unsaturated . . .	16.1	14.4	14.7	16.0	11.7
Aromatic . . .	17.8	22.5	27.5	18.6	19.0
Naphthene . . .	12.8	10.0	21.2	11.7	15.4
Paraffin . . .	53.3	53.1	36.6	53.7	57.9
Aromatic equivalent .	24.2	27.9	36.7	24.7	21.2
Highest useful com- pression ratio . . .	5.6	5.7	5.9	5.6	5.5

Garner [24, 1928] removes olefines and aromatic hydrocarbons simultaneously from cracked gasoline by the addition of fuming nitric acid, and the aniline point of the remaining oil is used for the estimation of the percentage of paraffin and naphthene hydrocarbons. The iodine number of the original gasoline is also determined, using the Hanus solution. Several analyses made according to this method were reported by Garner. He concluded that cracking of the gasoline increases the percentage of naphthenes.

Faragher, Morrell, and Levine [20, 1930] developed the following analytical procedure for the determination of olefine and aromatic hydrocarbons: (a) determination of the total olefine-aromatic content by treatment of the hydrocarbon distillate with 91% sulphuric acid, distillation to remove polymers, and final treatment with 98% sulphuric acid, and (b) removal of olefines with sulphur monochloride, distillation to remove the olefine-free oil, and determination of aromatic hydrocarbons in the olefine-free oil by nitration, determination of naphthenes by the aniline-point method and paraffins by difference.

Analyses of cracked distillate from representative oils showing the olefine and aromatic content are given in Table IV.

TABLE IV

Oil	Olefines	Aromatics
Smackover . . .	31.1	14.4
Venezuela . . .	20.6	17.8
Mexican (Panuco) . . .	27.8	15.1
Panhandle . . .	32.8	10.5
West Texas (Pecos) . . .	30.8	13.1
California . . .	21.4	14.1
Oklahoma (Seminole) . . .	29.1	9.0
Pennsylvania (1) . . .	25.5	9.9
Pennsylvania (2) . . .	34.6	7.1

Morrell and Levine [44, 1932] proposed an approximate method for the determination of olefine and aromatic hydrocarbons which is accurate to within 1 to 3% and which is considerably shorter than methods heretofore proposed. The sum of the olefines and aromatics is determined by treatment with 91 and 98% sulphuric acid, and the olefine concentrations may then be calculated from the weight of residue remaining after the distillation of the oil obtained upon treatment with 91% sulphuric acid by the use of empirical formulae.

The Kattwinkel method is also widely used for the determination of aromatics and olefines in oils [30, 1927]. The general principle of the method is that concentrated sulphuric acid containing small percentages of boric acid has no reaction on aromatics in mixtures containing them, but reacts with and removes olefines, while similarly sulphuric acid containing small percentages of phosphorus pentoxide reacts with both aromatics and olefines to effect their removal. The reagent for determining both aromatics and olefines is made by adding 30 g. of phosphoric pentoxide to 100 g. of sulphuric acid, the phosphorus pentoxide being added gradually with stirring and cooling. The reagent for olefines alone is made by adding 5 g. of boric acid to 100 c.c. of concentrated sulphuric acid, heating if necessary to effect solution. Aromatics and olefines are determined together by using 30 c.c. of the first reagent and 10 c.c. of the oil in a nitration tube, shaking for 5 minutes with cooling, and noting the percentage decrease in volume of the oil layer. Olefine hydrocarbons are determined by using the same proportions of the second reagent.

Influence of Cracking Conditions and Charging Stock on Composition of Cracked Gasoline

The chemical composition of cracked gasoline is influenced not only by the type of oil undergoing treatment but also by the conditions of cracking, namely, the temperature, pressure, and time. Practically no work has been done on the composition of cracked distillates from the viewpoint of the individual hydrocarbons contained therein.

Andreyev [1, 1929] has reported analyses of cracked gasolines produced from Russian gas oil at temperatures of from 500 to 600° C. and at low pressures.

The yields of products obtained were: benzene, 49%; liquid residue, 56%; gas and loss, 17%. The benzene had the following composition: aromatic hydrocarbons, 32%; unsaturated hydrocarbons, 40%; naphthene hydrocarbons, 12%; paraffin hydrocarbons, 16%.

A special benzene produced at 600° C. at low pressure and having an octane number of 110 showed the following hydrocarbon group composition: aromatics, 73%; unsaturateds, 20%; naphthenes, 5%; and paraffins, 2%.

The method of analysis employed for the hydrocarbon groups is not stated.

Sachanov and Tilicheev [53, 1928] cracked a paraffin containing distillate from Russian crude oil. The conditions of cracking in one set of experiments were 10 atm. pressure and a temperature of 425° C. The cracking time varied from 34 to 94 minutes. The specific gravity for fractions boiling above 300° C. increased regularly as the time factor was increased. In another set of tests a study was made of the composition of the gasoline and illuminating oils obtained in the cracking of paraffin-base distillates. Under the conditions of cracking employed the products from paraffin-base stocks consisted entirely of paraffins and olefines; naphthenes and aromatic hydrocarbons being practically absent.

According to these workers, the naphthenes in the cracked gasolines from charging oils of different composition vary within a small percentage range (4-7%), but these small variations are frequently significant in indicating the character of the oil cracked. The statement is made that most of the naphthenes in cracked distillate are formed from higher molecular weight naphthenes in the charging oils.

Sachanov and Tilicheev determined the chemical composition of cracked gasolines by first subjecting them to repeated fractional distillation to separate them into the following fractions: below 60° C., 60-95° C., 95-122° C., 122-150° C., and 150-200° C. Aromatic and unsaturated hydrocarbons were determined by the Kattwinkel method. The relative proportions of naphthenes and paraffins were determined by the aniline point after removal of aromatics and olefines. Both laboratory and plant samples of cracked gasolines were employed. The table summarizes the most important data:

Table V shows that the aromatic content increases from zero in the lower boiling fraction to percentages varying from 8 to 24 in the higher boiling fractions. The naphthenes increase from zero to 32%, the unsaturateds decrease from about 50% to 30%, and the paraffin content either remains constant or decreases slightly with rise in boiling point.

The authors state that the proportions of aromatics in a cracked gasoline are undoubtedly dependent on the proportion of aromatics in the stock cracked.

TABLE V

Content of Aromatics, Unsaturateds, Naphthenes, and Paraffins in Various Cuts of Cracked Gasolines

No.	Origin of the cracked gasoline	Boiling range of cuts ° C.	Content of various classes of hydrocarbons			
			Aromatic	Unsaturated	Naphthenic	Paraffinic
			% by weight			
1	Cracked gasoline from Grozny paraffin-base gas oil from the Vickers cracking unit	below 60	0	53	0	47
		60-90	1	33	14	52
		95-122	5	29	18	48
		122-50	8	29	16	47
		150-200	12	25	22	41
2	Cracked gasoline by heavy cracking to cokes of Grozny paraffin-base fuel oil. Laboratory experiments	92-122	4	36	14	46
		122-50	10	29	16	45
		150-200	24	15	15	46
3	Cracked gasoline from Surakhany fuel oil from the Vickers cracking unit in Baku	below 60	0	45	0	55
		60-95	1	36	10	53
		95-122	1	40	16	43
		122-50	5	37	18	40
		150-200	8	37	17	38
4	Cracked gasoline from heavy cracking down to coke of Surakhany fuel oil. Laboratory experiments	below 60	0	46	0	54
		60-95	0	36	13	51
		95-122	4	35	19	42
		122-50	9	31	24	36
		150-200	12	30	22	36

Sachanov and Tilicheev [53, 1929] sum up their work on the effect of pressure on cracking as follows:

1. Pressure *per se* has no influence on the yield of low-boiling hydrocarbons.
2. The yield of gasoline by cracking fuel oil at 10 atm. is somewhat higher than the yield at pressure from 20 to 80 atm.
3. The yield of gasoline from cracking heavy gas oil is slightly lower at 40 to 100 atm. than at 10 atm.
4. The yield of cracked gasoline when cracking paraffin wax at from 10 to 100 atm. remains practically constant.
5. The iodine numbers decrease rapidly with increase in pressure.
6. The percentage of naphthenes increases with increase in pressure from 10 to 40 atm.

Tilicheev and Masina [61, 1933] determined the total aromatic and unsaturated hydrocarbons in cracked gasoline by sulphonation. Aromatics were determined separately by difference after the removal of the unsaturated hydrocarbons. They determined the content of aromatic hydrocarbons in cracked gasoline from a commercial cracking unit and found that this did not change with temperature, provided the gasoline yield was unchanged. For example, when one type of cracking unit was operated at 490° C. and another cracking unit was operated at 405° C., the gasoline from each contained from 5% to 6% aromatics. The content of unsaturated hydrocarbons increased and that of naphthene hydrocarbons decreased with rise of temperature. According to these authors, the greater the extent of cracking the higher the content of aromatic and naphthene hydrocarbons in the cracked gasoline. However, the average composition of the total cracked gasoline from primary cracking and recycling operations is practically constant. The higher boiling cracked gasoline fractions are high in aromatics, particularly when made by repeated recycling.

Sager [54, 1933] cracked a Russian paraffin-base oil from the Grozny district, sp. gr. 0.889. The pressure at the entrance to the heating element was 300 lb., that of the reaction chamber was 200 lb., the flash chamber 15 lb.,

and the dephlegmator 190 lb. The transfer temperature was 914° F. The yields of products were: pressure distillate, 38%; residuum, 50%; gas, 12%. The chemical analysis of the distillate was: olefines, 7.2%; aromatics, 36.1%; naphthenes, 16.0%; and paraffins, 40.7%. Variations in the percentage of hydrocarbon groups over a range of temperatures of 475–95° C. and pressures over a range of 10–14 atm. were relatively small.

In another series of tests by Sager with the same charging stock the following results were obtained. The conditions of operation were: transfer temperatures, 914° F.; pressure entering furnace, 540 lb.; pressure in reaction chamber, 200 lb.; pressure in fractionating column, 30 lb. The yields of products by weight were: pressure distillate, 42%; residuum, 41%; gas, 17%. Analysis of the gasoline produced showed: olefines, 18.2%; aromatics, 48.8%; naphthenes, 13.5%; and paraffins, 19.5%. Chemical analyses in both cases were made according to the method of Egloff and Morrell.

A series of tests was made by Egloff and Morrell relating the type of charging stock to the chemical composition of cracked gasoline as determined by their method [14, 1926]. These tests were made in a laboratory pressure still consisting of a cylindrical shell set in a furnace and connected with vapour line, condenser, and receiver, and also provided with valves, pressure gauges, and temperature-measuring instruments. With this type of apparatus the permissible temperature range did not vary very widely over the pressure range employed, the average temperature being about 850° F., with pressures varying from 150 to 250 lb. It is believed that analyses of the gasolines produced from the various charging stocks are typical of the type of oil cracked, and that the range of temperatures and pressures had less influence in this series of tests than the type of oil charged. The results are shown in Table VI.

TABLE VI
Chemical Analyses of Cracked Gasolines
(Per cent.)

Gasoline source	Naphthenes	Aromatics	Unsaturates	Paraffins
Arkansas (Smackover)	21.2	27.5	14.7	36.6
California	16.7	22.0	23.0	38.3
Kansas	12.8	17.8	16.1	53.3
Kentucky	10.0	22.5	14.4	53.1
Michigan (Mt. Pleasant)	3.1	33.5	25.9	37.5
Oklahoma (Cushing)	18.0	19.8	10.9	51.3
Pennsylvania	10.2	23.5	9.7	56.6
Texas (Cole Bruni)	27.3	26.9	19.9	25.9
Texas (Mirando)	34.0	23.4	17.1	25.5
Texas (North)	11.7	18.6	16.0	53.7
Texas (Refugio)	25.0	32.8	30.0	12.2
Texas (Spindletop)	32.6	17.3	14.7	35.4
Texas (West)	16.8	38.5	27.1	17.6
Texas (West)	38.6	24.7	17.6	19.1
Wyoming (Lost Soldier)	14.5	15.9	11.7	57.9
Argentina	9.9	25.0	16.6	48.5
Canada (Wainwright)	13.2	24.7	18.6	43.5
Germany (Wietzer)	12.5	25.8	10.7	51.0
Mexico (Ebano)	15.9	22.6	13.8	47.7
Roumania	11.6	23.9	13.9	50.6
Venezuela (Mene Grande)	13.2	24.0	20.3	42.5

A comparison was also made by Morrell and Egloff (unpublished results) of the distillation curves of straight-run and reformed straight-run gasoline and cracked gasoline from the cracking of topped crude from Mt. Pleasant, Michigan, crude oil. The processing of these materials, together with the distillation analyses of the gasoline pro-

ducts resulting therefrom, are shown in Table VII. The Podbielniak distillation curves of the three gasolines are also shown together with the estimated constituents of the gasolines.

TABLE VII

	Straight-run gasoline	Reformed straight-run	Cracked topped crude
Conditions:			
Pressure, lb. per sq. in.:			
Chamber	..	1,000	250
Fractionating column	..	50	40
Temperature, ° F.:			
Transfer	..	940	940
Charge, gal. per hr.	..	2.00	0.76
Yield, %	32.25	81.6	67.5
Residuum, %	..	14.9	26.5
Topped crude, %	..	65.75	..
Loss, %	2.00	3.5	6.0
Gravity, ° API.	61.7	63.0	59.4
100 c.c. A.S.T.M. Distillation			
I.B.P., ° F.	152	105	102
5%	179	136	133
10%	190	154	154
20%	214	182	188
30%	236	206	218
40%	258	228	241
50%	278	252	274
60%	296	273	298
70%	310	300	320
80%	336	331	345
90%	360	368	371
E.P., ° F.	389	396	394
% Over	97.0	94.0	95.0
% Bottoms	1.5	1.0	1.0
% Loss	1.5	5.0	4.0
200 c.c. Podbielniak Distillation			
Propane, %	0.1	1.8	none
Butane, %	1.9	7.7	8.6
Higher hydrocarbons, %	98.0	90.5	91.4

(See Individual Distillation Curves.)

Composition of Vapour-phase Cracked Distillates

Birch and Scott [2, 1932] identified several diolefines in the lower fractions of a vapour-phase cracked gasoline.

Conjugated hydrocarbons were estimated quantitatively according to the method of Diels and Adler [12, 1928–9; 21, 1929] by the preparation of acid anhydrides formed by the addition of maleic anhydride. The products are characterized by definite crystalline form and by their melting-points.

According to Birch and Scott the quantitative estimation of diolefines in cracked distillates by this method appears also to be readily applicable to the cyclic diolefinic hydrocarbons, which react with maleic anhydride instantly with evolution of heat. The addition with the straight-chain diolefines is a slower process. Butadiene, isoprene, and piperylene all react slowly in the cold, but some polymerization of the two latter compounds appears to take place, as small amounts of rubber-like polymer are always formed. The same phenomenon has been observed with several of the dimethylbutadienes. Some of these give good yields of the addition products, while others produce large amounts of polymers.

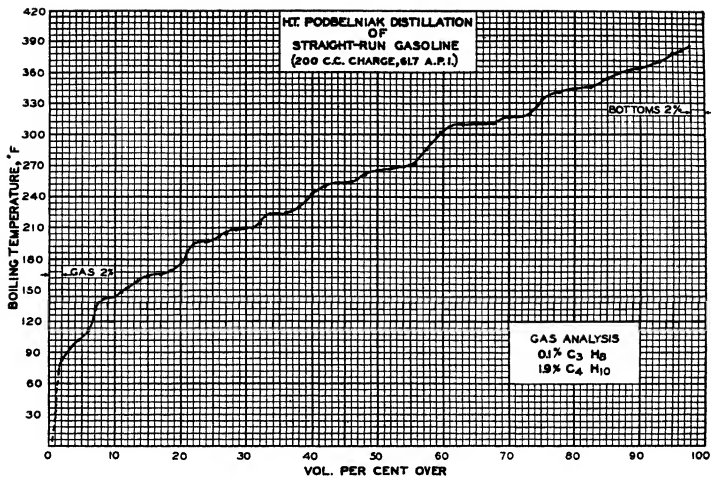

FIG. 1.

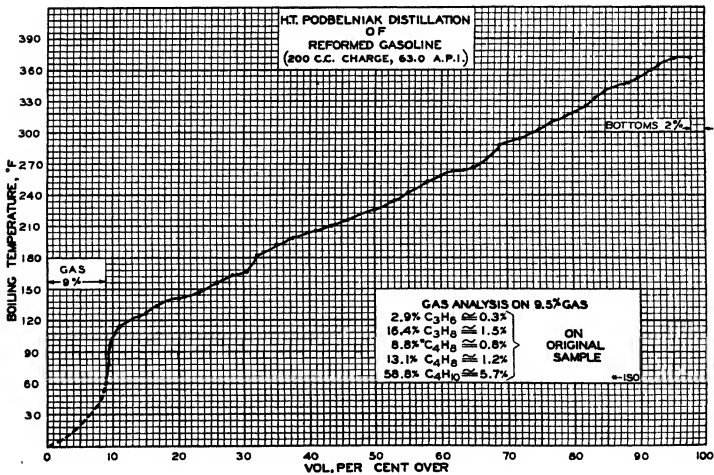

FIG. 2.

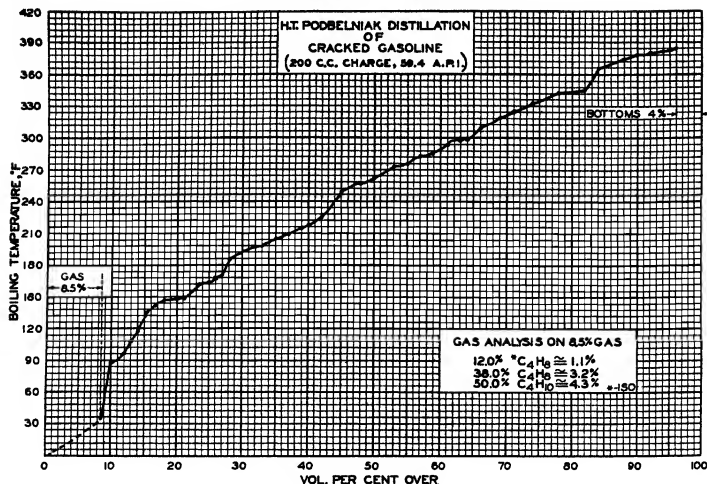

FIG. 3.

The examination of the lower fractions of comparatively close boiling range, derived from the compression gasoline from a high temperature cracking unit, and the corresponding gasoline itself, showed that butadiene, piperylene, isoprene, and cyclopentadiene were all present and these were easily separated. Preliminary attempts to isolate the corresponding derivatives from the dimethylbutadiene fraction were unsuccessful.

The composition of a butene-butane fraction and a pentene-pentane fraction has been reported by Brooks [7, 1935].

Payne and Lowy [48, 1932] made analyses of highly cracked gasoline before and after heat treatment, with the following results:

TABLE VIII

	Original vapour-phase distillate to 201.5° C. %	Heat-treated vapour-phase distillate to 201.5° C. %
Olefines . . .	35.0	24.5
Aromatics . . .	17.0	15.5
Naphthenes . . .	25.9	34.2
Paraffins . . .	22.1	25.8

From a list of the known hydrocarbons which may be contained in the highly cracked gasoline distillate, and from the boiling-points, specific gravities, and refractive indices as obtained from the literature, together with the information obtained experimentally on the 10° F. fractions from the heat-treated and original vapour-phase distillates, they

draw several conclusions as to the composition of the cracked distillates.

Typical analyses of various vapour-phase cracked gasolines are presented in Table IX.

TABLE IX

% unsaturates . . .	42.4	43.1	38.0	64.5	75.7
% aromatics . . .	57.6	38.6	46.3	28.1	20.8
% naphthenes	4.8	7.2	3.8	3.5
% paraffins	13.5	8.5	3.6	..
Total . . .	100.0	100.0	100.0	100.0	100.0

Additional analyses of three typical vapour-phase cracked gasolines are shown in Table X.

TABLE X

	Gasoline A	Gasoline B	Gasoline C
% unsaturated naphthenes and aromatics . . .	45.40	36.60	41.40
% saturated naphthenes . . .	3.06	2.96	2.30
% olefines . . .	38.20	48.60	58.40
% paraffins . . .	13.34	11.84	7.90

Private communication, Dr. Cary Wagner.

An investigation was made several years ago by Morrell and Egloff (unpublished results) to determine the relationship between the conditions of cracking several distillate stocks, the temperatures of cracking (including those where the oil undergoing treatment was substantially in vapour phase), and the composition with respect to hydrocarbon

groups of the resulting distillate products. The time of contact and rate of feed were noted, and coke and gas formation was determined.

The apparatus employed in these experiments consisted of a vaporizer, a reaction tube and/or chamber, a condenser, and a gas meter. Several sizes of reaction chambers were used to change the reaction time while maintaining a constant rate of feed.

Four different types of charging stocks were studied, namely, naphtha, 55.2° API. gravity; kerosine distillate; virgin gas oil; and pressure distillate bottoms. These were each cracked at temperatures of 900, 1,000, 1,100, 1,200, and 1,300° F., maintaining the rate of feed and the reaction time constant for various types of stock. The conclusions from the results of these operations are as follows:

1. The 55.2° API. gravity naphtha produced 72.8% of gasoline at 900° F. and 20.9% of gasoline at 1,200° F. There was present in the original naphtha, which boiled below 410° F., 3.9% of unsaturated hydrocarbons, 0.1% aromatic hydrocarbons, and 96% of naphthene and paraffin hydrocarbons combined. The gasoline produced therefrom at the optimum temperature of 1,000° F. contained 20.1% of unsaturated, 13.6% of aromatics, and 66.3% of paraffinic and naphthenic hydrocarbons. At 1,200° F., producing only 20.9% of gasoline because of large gas formation, the gasoline consisted of only two groups of hydrocarbons, namely, 36.0% of unsaturated and 64% of aromatic hydrocarbons. The paraffins and naphthenes were completely transformed into the unsaturated and aromatic hydrocarbons.

2. The maximum yield of gasoline per pass for the 36.7° API. gravity kerosine distillate was 31.5% at 1,000° F. The yields at 900° F. and at 1,200° F. were substantially the same, namely, 17.5-17.8%. The loss steadily increased as the temperature increased to a total of 59.4% at 1,200° F. At 1,000° F. the loss was 28%. The kerosine distillate contained originally 83.7% of paraffin and naphthene hydrocarbons and 16.3% of unsaturated and aromatic hydrocarbons. The gasoline produced by cracking at 1,000° F. contained 23% of paraffin and naphthene hydrocarbons, 52.0% of unsaturated, and 25% of aromatics. The coke production from the kerosine distillate was negligible at 1,000° F. Increasing the reaction temperature 200° F. raised the yield of coke over 10 times and increased the yield of gas about 8 times.

3. The 31.7° API. virgin gas oil also gave a maximum yield of gasoline of 28.0% at 1,000° F., and lower yields at both 900 and 1,300° F. The loss at 1,000° F. was 27.2%. The maximum loss was 68% at 1,300° F. At 1,000° F. and above, the gasoline was composed of two groups of hydrocarbons only, namely, unsaturated and aromatic hydrocarbons. The original gas oil contained 73.6% of naphthenes and paraffins, but the gasoline contained none of these hydrocarbons, thus showing complete conversion to unsaturated and aromatic hydrocarbons. The yield of coke at 1,000° F. was only 1.5 lb., and the yield of gas was 795 cu. ft. per barrel of gas oil. The coke and gas yields were both increased considerably by a rise of 100° F. in the reaction temperature.

4. The 37.8° API. gravity pressure distillate bottoms, which are typical of a once-thermolized stock, behaved like a virgin gas oil under the conditions of treatment. The maximum yield of gasoline of 29.3% was obtained at 1,000° F. The yields at 900 and 1,300° F. were substantially the same as obtained for the gas oil. The losses were about 35% less for the bottoms at 1,000° F., but approximately

the same as for the gas oil at the higher temperatures. The original bottoms contained 72% of paraffins and naphthenes and 24.6% of aromatic hydrocarbons, while the gasoline produced therefrom at 1,000° F. contained 60% of unsaturated, 26.6% of aromatics, and only 14.3% of naphthenes and paraffins. The pressure distillate bottoms produced coke and gas of the order of those produced by the kerosine distillate.

5. In general an increase in the reaction temperature on all charging stocks, irrespective of their source or gravity, causes an increase in the aromatic and unsaturated hydrocarbon content of the gasoline, and an increase in coke and gas production.

In general, with the stocks treated using times of contact from 138 secs. to 10 sec., the yield of gasoline gradually decreased from a maximum of 28% to a minimum of 16% at 1,000° F. The gas also decreased from 27.2% to 16.8% as the time of contact decreased. The amount of paraffin and naphthene hydrocarbons increased as the rate of feed of the oil increased. The coke and gas production decreased as the rate of feed or time of contact increased.

At 1,400° F. there was very little change in the yield of gasoline, and it averaged about 16.5% for the stocks treated. The loss was very high, varying from 72% to 58% as the time of contact changed from 120 to about 10 sec.

6. Tests were made to ascertain how much the yield of gasoline could be increased by recycling operations. The original gas oil was cracked, then stripped of its gasoline, and the bottoms recycled. These operations were repeated until the accumulated loss was equal to the loss obtainable by a single throughput of the oil at a slow rate of feed and long time of contact. This mode of operation increased the yield of gasoline 27%, decreased the yield of coke 32%, decreased the yield of gas 6.3%, and produced a composite gasoline with over 75% of unsaturates and about 20% of aromatic hydrocarbons. The gasoline from the single-step operation contained about 64% of unsaturated and 36% of aromatic hydrocarbons. Maximum gasoline yield is obtainable by recycling operations, but a limit of about 5 passes of oil exists according to these experiments.

Table XI on next page shows the results obtained in this series of tests.

Chemical Changes of Cracked Gasoline in Storage Peroxides, Aldehydes, Acids, and Gums

One of the important problems in the storage and sale of cracked gasolines is the maintenance of its desirable properties and the prevention of deterioration, particularly in respect to colour and gum formation and anti-knock properties. This deterioration generally is associated with oxidation phenomena occurring in storage, and a large amount of study has been devoted to it. In 1852 Schönbein (*Verh. d. Naturf. Ges., Basel*, 1, 501) recognized that turpentine, on exposure to oxygen, formed some compound of strong oxidizing power. In succeeding years other unsaturated substances were found to react with oxygen and form peroxides.

Smith and Cook [56, 1922] obtained evidence of aldehydes in aged cracked gasolines and considered them primarily responsible for the formation of gum. Brooks [6, 1926] stated that peroxides, aldehydes, alcohols, and ketones 'could easily be detected in samples of cracked gasoline which have become slightly oxidized'. He reported the identification of formaldehyde, acetaldehyde, propionaldehyde, and butyraldehyde in old gasoline; the

TABLE XI
 Effect of Type of Charging Stock

Run number	61	57	58	85	63	62	64	84	52	53	54	55	67	65	66	68
Condition of test	3-sec. time element				3-sec. time element				3-sec. time element				3-sec. time element			
Type of charging stock	Naphtha distillate				Kerosine distillate				Virgin gas oil				Press. dist. botts.			
A.P.I. gr.	552				367				317				378			
Average reaction temperature, ° F.	900	1,000	1,100	1,200	900	1,000	1,100	1,200	900	1,000	1,100	1,300	900	1,000	1,100	1,300
Charging rate, c.c. per hr.	222	222	222	222	222	222	222	222	222	222	222	222	222	222	222	222
Time of contact, sec.	68	63	59	56	160	148	138	129	149	138	129	114	160	148	138	129
Total charge, c.c.	500	1,200	1,100	1,200	1,000	1,100	1,100	1,000	1,000	1,100	1,100	1,200	1,000	1,100	1,100	1,100
Total recovery, %	98.0	78.0	41.1	32.8	94.5	72.0	46.5	40.6	92.3	72.8	46.5	32.0	98.5	80.9	50.1	32.6
Total loss, %	2.0	22.0	58.9	67.2	5.5	28.0	53.5	59.4	7.7	27.2	53.5	68.0	1.5	19.1	49.9	67.4
% Composite gasoline	72.8	69.7	32.2	20.9	17.8	31.5	23.0	17.5	14.5	28.0	23.6	15.2	14.5	29.3	23.7	15.1
A.P.I. gr.	54.5	55.5	44.7	41.2	51.8	52.3	44.2	36.7	55.4	52.9	42.9	31.9	48.5	50.0	44.6	32.0
% Unsaturation	7.8	20.1	34.7	36.1	44.1	52.0	54.6	42.4	53.9	63.6	48.0	17.2	44.6	59.1	56.2	19.4
% Aromatics	9.4	13.6	36.5	63.9	25.7	25.0	45.4	57.6	32.2	36.4	52.0	82.8	23.8	26.6	43.8	80.6
Naphthenes	5.8	..	4.4	6.0	11.9
% Paraffins	82.8	69.3	23.0	..	25.8	17.0	2.0	27.4	8.6
Coke, lb. per bbl.	none	0.32	0.38	2.4	none	0.29	1.5	3.6	1.4	1.5	3.2	10.0	none	0.44	1.2	8.6
Gas, cu. ft. per bbl.	none	631	1,800	2,320	98	280	1,727	2,170	134	795	1,800	2,800	none	388	1,463	2,492

aldehydes formed, he believed, by the splitting of the peroxides, and opposed the conclusion of Smith and Cook that aldehydes are intermediate in gum formation, as he found that addition of aldehydes to gasoline being evaporated did not increase the amount of gum formed. Brooks considered that the first step in gum formation is the formation of peroxides. The gum resulting after a long period of storage contained resinous acidic substances. He also demonstrated the marked influence of diolefines on gum formation as shown in the table.

 TABLE XII
 Influence of Easily Oxidized Hydrocarbons on Gum Formation

Expt.	Gasoline	Mg. per 100 c.c.
1	Straight-run gasoline + 2% limonene	46
2	Refined cracked gasoline + 2% limonene	634
3	Refined cracked gasoline alone	7
4	Straight-run gasoline + 5% isoprene and exposed to light 48 hours	52
5	Refined cracked gasoline + 5% isoprene and exposed to light 48 hours	521

Wagner and Hyman [64, 1929] also reported aldehydes, acids, and peroxides in old gasoline, and while they confirmed the findings of Brooks that addition of simple aliphatic aldehydes to gasoline did not increase its tendency to form gum, they found that crotonaldehyde did accelerate gumming. They also reported the odour of acrolein in gasoline oxidized under pressure.

Mardles and Moss [34, 1929] stated that 'the process of gumming appears to be initiated by the primary formation of organic peroxides . . . and the products of oxidation other than peroxides, namely, aldehydes, ketones, acids, &c., were found to have no accelerating effect on the gum rate'.

These earlier studies were largely qualitative in nature. Morrell, Dryer, Lowry, and Egloff [39, 1934] studied the rates of formation of peroxides and gum quantitatively in a number of samples of gasoline by bomb oxidation and in storage.

One of the conclusions which can be drawn from their work is that peroxides are the first products which are detectable when cracked gasoline deteriorates. They form at different rates in different gasolines, and in any one gasoline they build up with time at an increasing rate. As their concentration increases, other changes occur such as darkening in colour, gum formation, loss in anti-knock value, and in susceptibility to inhibitors. Peroxides decrease the effectiveness of inhibitors, but unless present in high concentration do not prevent their action entirely.

The same authors (loc. cit.) studied peroxidation of gasoline in relation to its composition by removing certain groups of hydrocarbons by a study of peroxidation of pure hydrocarbons. The properties of the gasolines were determined after removal of conjugated diolefines and again after elimination of all olefine hydrocarbons. The oxidizability of the pure hydrocarbons was studied by testing the hydrocarbons singly, blended with one another, and blended with gasoline.

A Pennsylvania and a California gasoline, both untreated and treated, were analysed employing the method of Faragher, Morrell, and Levine. The bromine numbers were determined according to the modification of the Francis method by adding the bromate solution at 0° as fast as taken up rather than all at one time. The analyses of the cracked gasolines are shown in Table XIII.

TABLE XIII

	Pennsylvania		California	
	Untreated	Treated	Untreated	Treated
Unsaturation, %	36.89	24.50	38.94	29.77
Aromatics, %	19.81	16.90	13.06	17.83
Bromine number	64	43	61	54
Induction period, min.	65	120	445	no break in 40 hr.

No relationship is apparent between the total unsaturated content of these gasolines and their tendency to oxidize as measured by induction period and formation of peroxides. The remarkable stability of the treated California gasoline, in spite of its high content of olefines, indicates that a large

proportion of unsaturated hydrocarbons need not make a gasoline unstable. The properties of gasoline are apparently more dependent on the type of unsaturates present than on their amount.

Morrell, Dryer, Lowry, and Egloff made a further study of the formation of peroxides, aldehydes, acids, and gums in typical cracked gasoline, particularly as to their distribution between the volatile portion of deteriorated gasoline, the gum dissolved in it, and the insoluble gum precipitated after severe oxidation. The elementary composition of the gum itself was also determined.

Their study shows that gum formed by evaporation of oxidized gasoline is high in peroxides, aldehydes, and acids. Gum precipitated from gasoline during oxidation is quite different in composition from the dissolved gum, a pronounced characteristic being its higher content of acidic substances.

If the total amounts of these oxidation products in fractions of oxidized gasoline are compared, the peroxides are usually found to be largely in the residue, the aldehydes fairly evenly distributed in all three cuts, and acids present in particularly large amount in the light fraction.

Study of gasoline being evaporated in gum tests, showed that peroxide, aldehyde, and acid are formed much faster in a copper than in a glass dish. Evaporation to dryness in the copper dish reduced or completely decomposed peroxides, leaving in the gum high concentrations of aldehyde and acid.

Colour in Cracked Gasolines

Brooks and Parker [9, 1924] conclude that the yellow colouring matter in freshly distilled cracked distillates is due to the presence of hydrocarbons containing conjugated unsaturated groups. This is indicated, according to them, by the ease of polymerizing these highly unsaturated yellow constituents by dilute acid, by heat alone, by fuller's earth, metallic sodium, &c., and by their rapid oxidation to form large proportions of gum. The colouring matter is not due to the presence of impurities containing oxygen and sulphur. The fulvenes are cited as examples of hydrocarbons containing conjugated double bonds which are definitely coloured and are various shades of yellow, orange, and red. As experimental proof that the yellow colours may be due to hydrocarbons only, they cracked a pure paraffin, protecting the distillate from oxidizing influences, and the distillate was found to be of a bright yellow colour.

Brooks states that the most common cause of the discoloration of gasoline is a trace of acidity, usually the result of air oxidation. Sulphur dioxide and sulphuric acid from its oxidation is the most common cause of this acidity. Oxidation of mercaptans to alkyl disulphides and finally to sulphonic acids may also cause discoloration. Gasolines which have not been acid-treated may develop acidity and discoloration. According to Brooks, one function of steam in redistilling acid-treated cracked gasolines is to take up the sulphur dioxide formed during distillation. Alkalis or oil-soluble bases prevent discoloration. Free sulphur may cause discoloration even in the absence of air.

Egloff, Morrell, Benedict, and Wirth [16, 1933] made a study of the effect of mercaptans, alkyl disulphides, and sulphur on the colour stability of gasolines when exposed to an arc light. They consider colour stability as divided into two factors: (1) actual formation of colour, and (2) development of a milky cloud or haze. The colour

stabilities of the gasolines were determined by exposing them to light from a carbon arc lamp under controlled conditions. The authors drew the following general conclusions from this work:

1. Mercaptans had no effect on the colour stabilities of Mid-Continent gasolines, and slightly decreased the stabilities of Pennsylvania cracked and blended gasolines. They caused colour and haze formation in the Pennsylvania straight-run gasoline.

2. Alkyl disulphides (a) occurring naturally, (b) added as pure compounds, or (c) formed during sodium plumbite sweetening, caused colour and/or haze formation in all gasolines upon light exposure.

3. Sulphur, added alone or in excess during plumbite sweetening, caused marked colour and haze formation in the gasolines exposed to light.

4. The presence of both sulphur and disulphides in all the gasolines except Pennsylvania cracked gasoline had more deleterious effects upon colour stability than when they were present separately.

5. Contacting sulphur and mercaptan-free gasolines with plumbite solution did not affect their colour stabilities.

6. The haze formed upon exposure of the gasolines to light could be removed by passing through filter-paper. Colour improvements resulted in all cases. The straight-run gasolines showed very marked improvement, returning to almost the original colour upon removal of haze by filtration, showing that the apparent colour of the unfiltered gasoline was mainly due to suspended particles. Filtration of cracked gasolines resulted in clarification with but slight improvement in colour, showing that the colour produced upon exposure was largely due to soluble coloured compounds.

Morrell, Benedict, and Egloff [38, 1935] made a further investigation on the photochemical formation of colour, haze, gum, and reaction products in gasolines in the presence of oxygen, nitrogen, and hydrogen, and the factors involved in the same. The source of light was a carbon arc lamp used in the earlier work. Their general conclusions from this work are as follows:

1. Refined Mid-Continent straight-run gasoline exposed to the carbon arc light in the presence of air or oxygen developed colour, gum, peroxides, acids, and aldehydes. The same effects were observed with cracked gasoline and blends. The straight-run and blended gasolines developed haze but the cracked gasoline did not.

2. The formation of gum, peroxides, acids, aldehydes, and haze did not occur in either the straight-run or cracked gasoline in the dark, even in the presence of oxygen, sulphur, or both, and at the same temperature as the samples exposed to the arc light. The reactions are therefore photochemical.

3. With oxygen and exposure to light the cracked and blended gasolines formed more gum than the straight-run gasoline.

4. Elementary sulphur increased the formation of colour, haze, and gum upon exposure of the gasolines to light in the presence of air or oxygen. Cracked and blended gasolines formed more gum with sulphur present than the straight-run gasoline.

5. With nitrogen, carbon dioxide, or hydrogen, colour and gum formed in the presence of sulphur. Hydrogen sulphide was evolved in all cases.

6. Haze particles contained sulphur dioxide and trioxide and/or corresponding acids and organic material. Most of the acid formed in the gasoline was found in the haze

particles which could be removed by filtration through filter-paper.

7. Removal of haze by filtration improved the colour but did not affect the gum content of the gasoline.

8. Exposure to light and air of straight-run gasoline from which sulphur and disulphides had been removed resulted in no haze formation and only a slight drop in colour.

An extension of this work on gasolines was made on the photochemical formation of colour, haze, and reaction products in pure hydrocarbons. The hydrocarbons used were: *n*-heptane; 2,2,4-trimethylpentane; 2-octylene; diisobutylene; cyclohexane; cyclohexene; toluene, cyclopentadiene; pinene; and limonene.

It was concluded from this work that chemical and physical properties of hydrocarbons as indicated by the bromine number and refractive index were practically unchanged by exposure to light either in the presence or absence of sulphur or *n*-propyldisulphide. The hydrocarbons could be recovered in as pure state as from the original distillation. The reactions resulting in the formation of colour, haze, peroxides, &c., under conditions of ordinary air exposure affect only a small proportion of the hydrocarbons.

The pure hydrocarbons formed no colour or haze upon exposure to light, with the exception of benzene which became coloured in oxygen, nitrogen, or hydrogen. Peroxides, aldehydes, and acids formed upon exposure of the hydrocarbons to light and oxygen. The olefine, cycloolefine, diolefine, and terpene hydrocarbons oxidized more readily than the paraffin, cycloparaffin, or aromatic hydrocarbons.

In general pure hydrocarbons or gasolines from which sulphur and disulphides had been removed were colour-

stable in light. The response to sulphur of paraffin, cycloparaffin, and aromatic hydrocarbons was similar to straight-run gasoline except that the straight-run gasoline had higher peroxide numbers in oxygen and formed mercaptans in nitrogen or hydrogen. The response of unsaturated hydrocarbons to sulphur was like that of cracked gasoline. The behaviour of hydrocarbons containing *n*-propyldisulphide was similar to gasolines. The disulphide had less deleterious effect on the colour stability of unsaturated hydrocarbons and cracked gasoline than it did on the stability of saturated or aromatic hydrocarbons or straight-run gasoline.

From the foregoing it is evident that while considerable work has been done on the composition of cracked distillates in respect to the hydrocarbon groups contained therein, namely, the paraffins, naphthenes, olefines, and aromatics, our knowledge of the individual compounds in cracked distillates is meagre. One may conclude from the group hydrocarbon analyses that the composition of cracked distillates varies as a function of cracking conditions, viz. temperature, pressure, and time, to which the stock undergoing treatment has been subjected, and also the type of oil undergoing treatment. An investigation to determine the individual components of cracked gasolines would have to include a large number of distillates based upon the source of the charging stock as well as the conditions of treatment. The methods applied to the analysis of the lower boiling fractions of crude oils, such as the various modifications of fractionation, would hardly suffice for their determination in cracked gasolines, but would have to be supplemented by chemical methods for the separation and identification of the individual hydrocarbons by the preparation of chemical derivatives. Without question, this field is a fertile and fascinating one.

REFERENCES

- ANDREYEV, P. N. *Petr. Times*, 32, 700 (1934).
- BIRCH, S., and SCOTT, W. D. *J. Ind. and Eng. Chem.* 24, 49 (1932).
- BOWREY, S. E. *J.I.P.T.* 3, 287 (1916-17).
- BRAME, J. S. S. *J.I.P.T.* 12, 221 (1926).
- BRAME, J. S. S., and HUNTER, T. G. *J.I.P.T.* 13, 794 (1927).
- BROOKS, B. T. *Ind. Eng. Chem.* 18, 1198 (1926).
- *Ind. Eng. Chem.* 27, 278 (1935).
- BROOKS, B. T., and HUMPHREY, I. W. *J.A.C.S.* 40, 822 (1918).
- BROOKS, B. T., and PARKER, H. O. *Ind. Eng. Chem.* 16, 587 (1924).
- CATLIN, L. J. *Refiner* 5, no. 4, 25 (1926).
- CONRADSON, P. H. *Oil and Gas J.* 28, no. 28, 111 (1926).
- DEELS, C., and ADLER, K. *Ann.* 460, 98 (1928); 470, 101 (1929); 476, 102 (1929).
- EDELEAULT, L. *Chem. Ztg.* 38, 391 (1914); *Petr. Z.* 9, 862 (1914).
- EGLOFF, G., and MORRELL, J. C. *Ind. Eng. Chem.* 18, 354 (1926).
- *Chem. Met. Eng.* 28, 633 (1923).
- EGLOFF, G., and MORRELL, J. C., BENEDICT, and WIRTH. *Ind. Eng. Chem.* 27, 323 (1935).
- ENGLER, C., and UEBELHORDE, L. *Z. angew. Chem.* 26 (1), 177 (1913).
- FARAGHER, W. F., MORRELL, J. C., and COMAY, S. *Ind. Eng. Chem.* 20, 5, 27 (1928).
- FARAGHER, W. F., MORRELL, J. C., and MONROE, G. S. *Ind. Eng. Chem.* 19, 1281 (1927).
- FARAGHER, W. F., MORRELL, J. C., and LEVINE, I. M. *Ind. Eng. Chem., Anal. Ed.* 2, 18 (1930).
- FARMER, E. H., and WARREN, F. L. *J.C.S.* 897 (1929).
- FRANCIS, A. W. *Ind. Eng. Chem.* 18, 821 (1926).
- GANTTNER, F. *Z. anal. Chem.* 32, 178 (1895).
- GARNER, F. H. *J.I.P.T.* 14, 695 (1928).
- GOHRE, A. *Petr. Z.* 23, 73 (1927).
- GRÄFE, R. *Chem. Abs.* 1, 1909 (1907); *Petr. Z.* 21, 147 (1925).
- GRIMALDI, C., and PRUSSIA, L. *Chem. Ztg.* 37, 657 (1913).
- HOLDS, D. *Petr. Z.* 18, 853 (1922).
- HOUGHTON, C. M., and BOWMAN, S. *J.I.P.T.* 11, 583 (1925).
- KATTWINKEL, R. *Chem. Ztg.* 49, 57 (1925); *Brenn. Chem.* 8, 353 (1927).
- LENSHER, V. U.S.P. 1,385,081 (1921); 1,473,350 (1923).
- MAQUENNE, L. *Comp. rend.* 114, 918 (1892).
- MARDEN, J. W., and DOVER, M. V. *Ind. Eng. Chem.* 9, 858 (1917).
- MARPLES, E. W. J., and MOSS, H. *J.I.P.T.* 15, 657 (1929).
- MOORE, R. J., MORRELL, J. C., and EGLOFF, G. *Chem. Met. Eng.* 18, 396 (1918).
- MORRAN, J. J., and SOULE, R. P. *Ind. Eng. Chem.* 15, 693 (1923).
- MORGULIS, S., and LEVINE, V. E. *J.C.S.* 120 (1), 17 (1921).
- MORRELL, J. C., BENEDICT, E., and EGLOFF, G. Paper before the American Chemical Society meeting in New York, 1935.
- MORRELL, J., DRYER, C. G., LOWRY, C. D., and EGLOFF, G. *Ind. Eng. Chem.* 26, 497 (1934).
- MORRELL, J. C., and EGLOFF, G. *Oil and Gas J.* 25, 150, 154, 157 (1927).
- *World Petr. Congr.* London, 1933.
- 2nd Int. Conf. on Coal. Proc. 2, 580, 613 (1928).
- *Ind. Eng. Chem.* 17, 1259 (1925).
- MORRELL, J. C., and LEVINE, I. M. *Ind. Eng. Chem., Anal.* 2, 18 (1930); 4, 321 (1932).
- NANETSKIN, S. S., and ABRAKUMOVSKY, L. *J. prakt. Chem.* 115, 56 (1927).
- NAFTUKOV, A. M. *J.S.C.I.* 23, 1082 (1904).
- ORMANDY, W. A., and CRAVEN, E. C. *J.I.P.T.* 13, 311, 846 (1927).
- PAYNE, C. A., and LOWY, A. *Ind. Eng. Chem.* 24, 432 (1932).
- PLAUBON, H. U.S.P. 1,436,289 (21 Nov. 1922).
- REB, H. B.P. 113,098 (30 Jan. 1918).

OXIDATION AND OXY-COMPOUNDS

NAPHTHENIC ACIDS, OXY-COMPOUNDS, ETC.

By Professor JULIUS VON BRAUN, Ph.D.

University of Frankfurt

THE oxy-compounds present in petroleum are remarkable for two reasons: (1) the percentage present is very small; (2) they are difficult to obtain in the pure state. Due to the difficulty in obtaining the pure compounds from mixtures of closely related substances, their constitution is not definitely known. This is as true for the two classes of compounds which are so far relatively the best known, namely, the phenols and the carboxylic acids, as it is for the remaining constituents of petroleum containing oxygen and which therefore can be briefly touched upon.

If the following interesting facts are disregarded, then only two important points remain to be recorded. The biological action, just as that of lignite and coal, shows the probable presence of follicle hormone (Aschheim and Hohlweg [5, 1933]). Robinson [61, 1889] has apparently succeeded in detecting the presence of acetaldehyde in Pennsylvanian oil, and Marcusson [44, 1922] that of alcohols and aldehydes or ketones in some cylinder oils. The two remaining points are: firstly, that oxygen and sulphur are contained in the asphaltic material (Marcusson [43, 1915-17]), concerning whose nature practically nothing is known. Secondly, that the occasional presence of substances of an ester character and high molecular weight has been found in American, Russian, and German varieties of petroleum, in accordance with observations of their behaviour on saponification (Kraemer [39, 1907]). The substances themselves have not yet been isolated.

References to the occasional occurrence of phenols in crude and in distilled petroleum are found in the literature of the past few years, but here it is a question rather of qualitative observations, which did not lead to the obtaining of individual compounds in the pure state. Only in the last few years have the investigations of Story and Snow [71, 1928], of Tanaki and Kobayashi [73, 1927], and Holzmann and v. Pilat [32, 1930] thrown more light upon the situation. According to these, mixtures of phenols can be isolated from the alkaline petroleum extracts which contain principally naphthenic acids (see below). The extracts are acidified to liberate the dissolved matter, the acids are neutralized with sodium carbonate, and the phenols freed from hydrocarbon impurities by solution in alkali and repeated extraction with ether or petroleum ether. By careful distillation and conversion into characteristic derivatives (e.g. into urethanes, or reaction products with chloracetic acid), the presence of the three cresols in American, Japanese, and Polish petroleum was ascertained. In Japanese and Polish petroleum xylenols were found, together with di- and tri-ethyl phenol in the Japanese oil. β -Naphthol was also present in the Polish oil. The presence of the simplest phenol was never found in these oils. Finally, it was shown that the amount of phenolic matter isolated from the undistilled crude oil was much less than that obtained from distilled oil, and especially less than that obtained from cracked petroleum. It may probably be assumed that a thermal alteration in the direction of the phenols takes place, the bodies undergoing these changes

being substances of high molecular weight; their nature being as yet unknown. The author also made some quite similar observations recently, ascertaining the presence of phenols in oils of other origin as well (e.g. from Roumania, Germany and Venezuela).

The principal interest in the realm of the oxy-compounds contained in petroleum is concentrated on the typical acid compounds, which outweigh the others in quantity, and have occupied the attention of a number of investigators for 60 years. Following the discoveries of Eichler [23], Hell and Meidinger [31], in 1874, of substances of typical acid character in Russian and Roumanian oils respectively, and after Hell and Meidinger had ascertained the formula $C_nH_{2n-2}O_2$ for them, some investigators (Zaloziecki, Charitschkov) temporarily suggested the following complicated formula of the lactone alcohols:

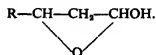

The fundamental investigations of Markovnikov and Ogloblin [46, 1883] showed, however, that these acids actually contained carboxylic groups and were therefore acids in the real sense of the word.

They appeared as derivatives of the monocyclic hydrocarbons, which are isomeric with the olefines, and since the name 'Naphthenes' had been coined for these, the acids were given the name 'Naphthenic acids'. After it was shown in the course of time that the acids which could be isolated from petroleum did not all correspond to the formula $C_nH_{2n-2}O_2$, and particularly after aliphatic acids richer in hydrogen, $C_nH_{2n}O_2$, had been proved to be present in petroleum, some uncertainty in the nomenclature arose. The author considers it to be more just not to limit the name 'Naphthenic acids' to cover only the monocyclic compounds, but to extend it to include the whole of the acids which can be isolated from petroleum. Thus their origin would be defined. In this way the name will comprehend the aliphatic acids $C_nH_{2n}O_2$, which are sometimes met with; the $C_nH_{2n-2}O_2$ type and the bicyclic acids $C_nH_{2n-4}O_2$. These latter, although poorer in hydrogen, constitute a large part of the natural material. With few exceptions we are at present unable to give each of the natural naphthenic acids a rational name depending on the constitution. We are not even able to obtain as homogeneous material single members from natural mixtures of naphthenic acids, as will be shown in detail later. The only thing that is certain is that definite naphthenic acids occur again and again in petroleum of different origin, so that their total number is perhaps not excessively great.

The extraction of the crude mixtures of naphthenic acids which are contained in a particular sample of petroleum is comparatively simple, for it depends on their solubility in alkali; it is more difficult to remove from such a mixture all impurities which are not naphthenic acids. The

production of crude naphthenic acids takes place in the course of refining the petroleum, using sulphuric acid and alkali. The crude oil or separate fractions of distilled oil are stirred in mixing-vessels with concentrated sulphuric acid (0.5-1% for benzine, 2-4% for kerosine, 5-10% for lubricating oil), the lower layer consisting of acid tar is drawn off, and the oily layer is stirred up with 2-5% caustic soda, it sometimes being necessary to heat the mixture. The stirring is partly mechanical and is partly accomplished by blowing a stream of air through the mixture. The acids together with some naphthene sulphonic acids formed by the sulphuric acid go into the alkaline layer. This is then separated off after standing for some time. Reference may be made here to a point which will be dealt with later. According to recent investigations, neither the treatment with sulphuric acid nor with alkali noticeably alters the chemical nature of the naphthenic acids originally contained in the petroleum, so that in this way a material is obtained which is identical with the natural product. This material in the alkaline extracts is still very impure, being particularly contaminated with hydrocarbons from the petroleum, which are emulsified by the naphthenic acid soaps. The higher the specific gravity of the oil and the more concentrated the lye, the greater will be the emulsion. Contamination with hydrocarbons to the extent of more than 70% has been observed. Usually, therefore, in order to prevent losses of the oil, the refining is carried out with dilute caustic soda, the lyes being allowed to stand for long periods in collecting reservoirs, so that at least part of the oil may settle. The greater part of such lyes are evaporated down, salted out with common salt, and worked up to soda soaps of the naphthenic acids. If these crude acids themselves are required, they are precipitated with dilute sulphuric acid.

The classical method for the production of naphthenic acids has been improved in recent years by some variations which may be briefly mentioned here. For the technical details reference may be made to the works of the following authors: Naphtali [49, 1927; 50, 1934], Gurwitsch and Moore [29, 1932], and Carleton Ellis [24, 1934].

(1) As the usual methods of refining petroleum are displaced by other methods such as selective solvents and adsorbent earths, so the formation of acid tar becomes less and less, the alkali treatment only remaining.

(2) Naphthenic soaps can be obtained by stirring the oil with sodium carbonate, adding alcohol, drawing off the alcoholic extract, and removing the alcohol from it by distillation.

(3) Further, the soap solutions which have been obtained by means of sodium carbonate or caustic soda may be freed from the greater part of the oil which they still contain by evaporation or vacuum distillation.

(4) Sulphur dioxide can be used in place of the sulphuric acid to liberate the naphthenic acids from their soaps, this making it possible to regenerate the alkali by treating the sodium sulphite formed with quicklime.

The technical naphthenic acids or their sodium derivatives obtained by one method or another are still far from being pure. Their complete purification presents a difficult problem, which has not been satisfactorily solved for the higher members of the series. On a technical scale a certain amount of purification can be achieved by first redistilling the product and then allowing it to stand for some time with fuming sulphuric acid. After the addition of water the dark colour becomes lighter and the odour, which is usually disagreeable, is partly removed. The same object is achieved by treatment with various oxidizing agents. To

remove traces of oil still remaining in the acids it has been proposed that the product could be stirred with bases such as aniline and *o*-toluidine, or with acetic acid and petroleum ether. In the former case the bases would mix only with the acids, so that an oily layer would separate out. In the case of acetic acid and petroleum ether, the former would dissolve the acids and the latter the hydrocarbons. A more scientific method is that of Spitz and Höning. The naphthenic acid mixture is esterified with methyl alcohol, the mixture of esters well washed with alkali and distilled. The distillate is then saponified with alkali and extracted repeatedly with petroleum ether, after the addition of a little alcohol. The process is then repeated. Even this effective mode of operation does not always bring about the removal of the last traces of oil impurities, and the author [6, 1931] was able to gain definite knowledge of the true composition of the naphthenic acids contained in the different oils by the following method. The naphthenic acids, like all organic acids, can be converted into the corresponding amines by the help of several well-known methods, such as those of A. W. Hofmann and T. Curtius. A new and better method is that of K. F. Schmidt [64, 1929, 1932], which consists in the action of azoic acid on carboxyl compounds in the presence of concentrated sulphuric acid. The reaction proceeds according to the following:

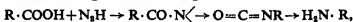

and enables the amine to be prepared very easily in a single operation, and with yields up to 90%. The amines formed from naphthenic acids have the remarkable property that they can be much more thoroughly freed from oil, since their capacity for emulsifying with the oil is much less than that of the acids themselves. By means of a few sparingly soluble salts, particularly the oxalates, a perfect purification is thus possible. In this manner it has been possible to show that in general the naphthenic acids contain three classes of acids which differ in the proportion of hydrogen which they contain: those with composition $\text{C}_n\text{H}_{2n-2}\text{O}_2$, those of the $\text{C}_n\text{H}_{2n-4}\text{O}_2$ type, and finally those with composition $\text{C}_n\text{H}_{2n-6}\text{O}_2$. The first (paraffin carboxylic acids) constitute the lower boiling portions and have 6 and 7 carbon atoms; the acids $\text{C}_n\text{H}_{2n-4}\text{O}_2$ which were at one time regarded as the real petroleum acids contain 8 to 12 carbon atoms. All those acids with higher molecular weights, with molecules going up to C_{22} or C_{23} (which may be generally the upper limit for the naphthenic acids), belong to the series $\text{C}_n\text{H}_{2n-6}\text{O}_2$. Until recently the author believed that the boundaries between these three classes were sharply defined and were the same for oils from all sources. The latter is probably the case, but recent exact experiments have shown that the boundaries overlap somewhat. Paraffin carboxylic acids occur as a rule in the material C_6 to C_{13} , and traces of acids of the formula $\text{C}_n\text{H}_{2n-4}\text{O}_2$ occur in the material with more than 12 carbon atoms. As far as we know at present, Polish petroleum which is rich in paraffins is the only one which occupies an exceptional position with regard to its composition: the acids $\text{C}_n\text{H}_{2n-4}\text{O}_2$ are missing (exceptionally petroleum of Krosno), whereas the paraffin carboxylic acids are more in evidence and can even be obtained from the higher boiling fractions. It should be noted that the presence of paraffin carboxylic acids of low molecular weight, with 7 carbon atoms (*iso*-amyloacetic acid and di-ethyl propionic acid), was ascertained by Tschitschibabin [76, 1932] in Baku oil. This was found by investigation of the cadmium salts of the Baku naphthenic acids. Alleman [2, 1928] believes he has detected acids

properties are much greater, hence they are used technically for soaps and washing materials. Their dark colour can be fairly completely removed by treatment with adsorbent earths. The ammonium, potassium, and lithium salts which are readily soluble in water and the magnesium calcium and barium salts which are more sparingly soluble are not of special interest. The solubility of the calcium salts in oil increases the viscosity, and such solutions are sometimes recommended as substitutes for lubricating oil. The aluminium and heavy metal salts are of interest on account of their remarkable behaviour: they are insoluble in water and alcohol and can therefore be obtained by precipitation with the salts of the metal concerned, from alkali-naphthenate solutions. They are, however, soluble in benzene, benzine, and similar organic solvents. On evaporation of the solvent, the salt remains in a plastic elastic mass, which with aluminium and lead salts is colourless. The colour with manganese salts is pink, with ferrous salts green, with ferric salts reddish brown, and with chromium salts violet and green. The copper salts which dissolve in benzine with a beautiful green colour are particularly characteristic and are important for the detection of the naphthenic acids (Charitschkoff reaction [14, 1897]). These salts serve various purposes: they are used for insulating materials, for adhesives, and for varnish substitute. On account of their antiseptic properties the copper salts are used for the impregnation of wood, &c. Solutions of cobalt, manganese, and lead salts in fatty acids serve as paint and varnish driers (Soligen). In conclusion it may be mentioned that the formation of the heavy metal salts also takes place by direct action of the naphthenic acids on the metals in the presence of air, although only to a small extent. Aluminium is not attacked at all.

The esterification of the carboxyl group takes place in a perfectly normal manner with the methods customary for the carboxylic acids, and goes as well with the simple alcohols as with those containing two or more hydroxyl groups (methyl-, ethyl-, amyl-, cyclohexyl-alcohol; phenol, glycol, glycerol, penta-erythritol, and cellulose). Of the simple alcohols the most important is methanol, because, as already mentioned, a high degree of purity of the crude naphthenic acids can be attained by way of the methyl esters. They boil 40–50° lower than the corresponding acids, and have an odour which is at first pleasant, but which becomes disagreeable. The glycerol esters are used in the manufacture of lacquer, and are also suitable for wetting agents. When used for this latter purpose a small difference in the composition of the naphthenic acids makes a noticeable difference in the strength of the wetting properties. By reduction with sodium and alcohol, or by catalytic reduction, the esters of the naphthenic acids $R \cdot CO_2R$ and the acids themselves can be reduced to the corresponding alcohols $R \cdot CH_2OH$. (For the technical details see the patents of the Deutsche Hydrierwerke A.G. [19, 1931, 1932].) Some of these can be distinguished by their agreeable odour, especially the series C_9 to C_{11} , and when esterified with acetic and propionic acids the esters formed possess a fragrant and pleasant smell [6, 1931]. The treatment of the alcohols of higher molecular weight with sulphuric acid or chlorosulphonic acid leads to the formation of sulphonic acids with detergent properties. The substitution of $-OH$ by chlorine or bromine yields chlorides or bromides which form a valuable material for further changes. Some of these reactions will be dealt with below, but it may be mentioned that suitable reduction of these halogen compounds (e.g. with

sodium and alcohol) leads to the formation of hydrocarbons; thus, Komppa [38, 1929] succeeded in preparing a hydrocarbon $C_{11}H_{22}$ from the naphthenic acid $C_{10}H_{18}COOH$ in Baku oil by way of the ester, the alcohol, $C_{10}H_{17}CH_2OH$, and the corresponding chloride $C_{10}H_{17}CH_2Cl$. This hydrocarbon was very similar in its properties to a hydrocarbon of the same composition which had been obtained from Baku oil. It would appear, therefore, that the acid $C_{11}H_{22}COOH$ is a simple oxidation product of this naphthene $C_{10}H_{18}CH_2$. The conversion of the naphthenic acids to the chlorides proceeds perfectly normally; the chlorides then give with ammonia or organic amines the corresponding amides. The unsubstituted amides $R \cdot CONH_2$ are solid and crystalline, but this property cannot be used in the separation of homogeneous products from mixtures of naphthenic acids by fractional crystallization (v. Braun [6, 1931]). The naphthenic acid amides can be converted in the usual way into the nitriles $R \cdot CN$ (Aschan [4, 1891]), and these can be reduced to the amines $R \cdot CH_2 \cdot NH_2$.

Much easier and quicker than the conversion into one of the amines $R \cdot CH_2 \cdot NH_2$ referred to above is the conversion of a naphthenic acid $R \cdot COOH$ into an amine $R \cdot NH_2$ by substitution of the carboxyl group by an amine group. It is true that the conversion can be carried out by the older methods of Hofmann and Curtius, already mentioned, but the method of K. F. Schmidt [64, 1929, 1932] has proved to be much more practical. This consists in slowly allowing a solution of azoic acid in benzene or chloroform to react with a solution of naphthenic acid in concentrated sulphuric acid, at about 40° C. When the evolution of nitrogen has ceased the product is poured on ice, the organic solvent distilled off, and the amine liberated with alkali. These amines, a large number of which have been prepared by the author, are characterized by all the properties of the non-aromatic amines. Many of them form crystalline salts and derivatives, and they show greater boiling-point intervals than the mixture of acids from which they originated. For instance, an acid mixture boiling between 148 and 155° C. under 12 mm. pressure yields an amine mixture boiling between 178 and 200° C. at ordinary pressure; this, of course, greatly facilitates the fractional separation of the components.

While the substitution of the carboxyl group by NH_2 is thus easy to accomplish, it is very difficult to replace it by hydrogen and so obtain the fundamental hydrocarbon corresponding to the acid. In agreement with the older experiments by Krämer and Böttcher [40, 1887] the author found that decarboxylation by heating with soda-lime or sodium methylate proceeded only with difficulty and was accompanied by secondary reactions. Ipatiev and Petrov [36, 1930] showed recently that by heating naphthenic acids with water under pressure in the presence of alumina an extensive disintegration of the molecule resulted. A further problem, which has not been solved, is the conversion of the naphthenic acids $R \cdot COOH$ into the ketones $R \cdot CO \cdot R$. This was last tried by Stadnikov and Donde [68, 1923] using Grün's method, but without success. Zelinsky and Rjachina [82, 1924] succeeded in obtaining the mixed ketones $R \cdot CO \cdot CH_3$, e.g. $C_9H_{16}CO \cdot CH_3$, $C_{10}H_{18}CO \cdot CH_3$, and $C_{11}H_{20}CO \cdot CH_3$, from some naphthenic acids and acetic acid.

In regard to the conversion of the hydrocarbon radical united with the carboxyl group, it may be mentioned that it offers considerable resistance to chemical change; only in the immediate neighbourhood of the carboxyl group

does any change take place more easily. The pure naphthenic acids are therefore very resistant to oxidizing and reducing agents; they do not absorb hydrogen and remain unchanged with sodium and alcohol as well as with acids and metals. They do not give Baeyer's permanganate test, but are slowly attacked to a slight extent on warming with potassium permanganate in alkaline solution, with the formation of manganese dioxide. There is no noticeable change on treatment with 3-5% ozone. All these facts indicate that the molecule contains no double bonds. With some higher boiling naphthenic acids, observers have found small iodine values (e.g. Schwarz and Marcusson [65, 1909] and Pyhäälä [58, 1913]), but since the material used was not pure, it was undoubtedly the impurities which caused this behaviour. The naphthenic acids are absolutely stable with regard to concentrated sulphuric acid and can be recovered without any appreciable change even after prolonged heating. The action of fuming sulphuric acid, on the other hand, leads to a large amount of sulphonation (Radcliffe), but an exact investigation into this reaction, and the characterization of the sulphur-carboxylic compounds thus produced, has not yet been forthcoming. Whether naphthenic acids are slightly sulphonated during the refining of petroleum with sulphuric acid is another point which has not yet been settled.

The treatment of the naphthenic acids with bromine and phosphorus by the method of Hell-Volhard-Zelinsky leads, according to the author [6, 1931], to a ready bromination in the α position to the carboxyl group, just as with the non-aromatic carboxylic acids. On pouring the primarily formed brominated acid bromides into alcohol, the esters of the α -brominated carboxylic acids are obtained. These can be distilled without decomposition, but, unfortunately, they do not allow of an easy splitting off of hydrogen bromide with the tertiary bases and the consequent formation of α - β unsaturated acids, as with many aliphatic acids (M. Merkel [47, 1915] and C. Dietsche [21, 1922]). The original saturated acids are formed together with α - β unsaturated acids in some obscure reaction. A second reaction of greater importance with regard to the investigations into the naphthenic acids is that between phosphorus pentachloride and the naphthenic acid amides; with substitution taking place on the nitrogen atom with an aromatic or aliphatic group ($R \cdot CO \cdot NH \cdot R'$ or $R \cdot CO \cdot NH \cdot R''$) [6, 1931]. As the author was able to show in 1927 (v. Braun, Jostes, and Münch [9]), the action of excess phosphorus pentachloride on such amides $R \cdot CO \cdot NH \cdot R'$ derived from a non-aromatic acid produces firstly the imide chloride $R \cdot CCl = NR$; the hydrogen adjacent to the group $CO \cdot NH \cdot R'$ is then substituted by chlorine. An acid $R' \cdot CH_2 \cdot COOH$ yields, therefore, first $R' \cdot CCl_2 \cdot CCl = NR$ and then after hydrolysis $R' \cdot CCl_2 \cdot CO \cdot NH \cdot R$; an acid $R' = CH \cdot COOH$ yields $R' = CCl(C) = NR$ and then $R' = CCl \cdot CO \cdot NHR$; and an acid $R' = C \cdot COOH$ gives only $R' = C(C) = NHR$ and then $R' = C \cdot CO \cdot NR$ without entry of chlorine into the molecule of the acid, since the hydrogen atoms not in the α position are not susceptible to substitution. By analysis of the resulting imides it is thus possible to decide whether the carboxyl group in a given acid is primary, secondary, or tertiary, i.e. whether the grouping $-CH_2 \cdot COOH$, $=CH \cdot COOH$, $\equiv C \cdot COOH$, or a mixture of these is present. This imide

chloride method has been found well suited to the naphthenic acids, even with the higher members, and has led to the conclusion that they chiefly contain the grouping $-CH_2 \cdot COOH$.

Due to the limitation of space, questions concerning the analytical investigation of the naphthenic acids and their soaps, particularly the technical products, which depend on their chemical and physical properties, cannot be dealt with fully. Reference should be made to the works of Naphthali and Gurwitsch [49, 1927; 50, 1934; 29, 1932], and also of Budowski [12, 1922]. The reader is reminded of the sensitive copper reaction of Charitschkov [14, 1897], and it may be mentioned that v. Pilat and Sereda [55, 1934] quite recently succeeded in finding a solution to the important problem of estimating naphthenic acids in the presence of naphthene sulphonic acids. The solution is based on the fact that the naphthene sulphonic acids, being the stronger acids, react with common salt to give the sodium salt, while the naphthenic acids do not react.

Concerning the physiological behaviour of the naphthenic acids, the most interesting fact is their odour. With the crude compounds this is very objectionable, particularly in the lower boiling fractions, but less so with those of higher boiling-point. This frequently represents an obstacle to the technical application of the acids. At present there is very little to state with any certainty regarding the cause of the odour, the following points being definite, however: (1) Naphthenic acids isolated from the crude oils not refined with sulphuric acid smell less strongly than those obtained from acid refined oil. (2) Naphthenic acids obtained by saponification of their carefully distilled esters have very little odour when fresh, but acquire the disagreeable smell after a little time. (3) The trimethyl-cyclopentyl-acetic acid obtained synthetically by the author from the $C_{10}H_{14}O_2$ naphthenic acid mixture by way of trimethyl-cyclopentanone, and which is contained in the isomeric $C_{10}H_{14}O_2$ acid mixture (see below), has certainly a fatty odour, but it is not that of the actual naphthenic acids. From these facts it may be concluded that the odour of the naphthenic acids is caused by a slight impurity, which perhaps does not necessarily belong to the class of sulphur compounds, as it is sometimes assumed. It may be readily formed from certain naphthenic acid molecules and be destroyed by chemical means, especially by the use of an oxidizing agent such as potassium permanganate (Breda [11, 1906]), by nitrous and hypochlorous acids (Erdölgesellschaft [25, 1916]), and by the salts of the per-acids (Vereinigte chem. Werke, [77] 1906). It can, moreover, also be removed by reduction (Pohl 56, 1922), and finally by heating the soap solutions under pressure (Stiepel 70, 1918), although the smell is not always completely removed.

Another point of physiological interest, apart from the odour, is the toxicity of the naphthenic acids. Kupzis [41, 1902] ascertained that the naphthenic acids are poisonous to fishes, frogs, and crabs, but less poisonous to dogs and human beings. Cats are affected to a somewhat greater extent. The acids possess powerful bactericidal properties; Spalwing [67, 1903] showed that the naphthenic acids of lower molecular weight were more effective than those of higher molecular weight. The metallic salts possess similar antiseptic properties.

The main question of interest to the chemist is that of the molecular structure of the naphthenic acids. Every detail cannot be explained, but the general outline can be indicated. In the development of the structure there are

two distinct periods: (1) to 1931, when the true composition was established; (2) from 1931 to the present time. In the first period the acids examined were principally those of medium molecular weight from Russian and Roumanian petroleum, and those of higher molecular weight from Polish, Galician, and Japanese oils. Since all these acids are saturated and correspond to the formula $C_nH_{2n-2}O_2$, the idea arose that the naphthenic acids were polymethylenes with a carboxyl group attached; that this polymethylene ring is a 5- and not a 6-atom ring, and that the carboxyl group is directly attached to it was inferred from some important investigations by Markovnikov, Aschan, Zelinsky and their co-workers. In 1899 Markovnikov [45] found that an acid $C_7H_{12}O_2$, isolated by Aschan in 1890 from Baku petroleum, could be converted to an *o*-methylcyclopentylamine (I), and that the acid was therefore *o*-methylcyclopentylcarboxylic acid (II):



After the isolation of a further number of acid mixtures $C_nH_{2n-2}O_2$, by a series of workers (Aschan [4, 1891], v. Pilat and v. Kozicki [53, 1915], Zelinsky [80, 1924; 81, 1924], Frangopol [22, 1910], Tanaka [72, 1923-5], and others), Zelinsky was able to show in an investigation in 1924 the following important facts. He found that when the methyl esters of a series of these acids (with 8, 9, and 10 carbon atoms) are reduced to alcohols, these then converted to the iodides and the iodide replaced by hydrogen (as in Kompas's experiments), the naphthenes which resulted could not be dehydrated to give aromatic compounds. Presumably, therefore, these acids contain a pentamethylene ring like the acids of Aschan and Markovnikov. To this knowledge was added the discovery of Tanaka and Kuwata [74, 1928] that small quantities of palmitic, stearic, and myristic and arachidic acids could be isolated from some of the higher acid fractions of oils from Japan, California, and Borneo, and the discovery of v. Pilat and Holzmann [52, 1931], who found arachidic acid in a spindle oil of Polish origin.

This simple conception of the constitution and structure of the naphthenic acids has undergone considerable expansion since 1931, due to the investigations of the author and his many co-workers [6, 1931]. Firstly, they were able to show, after converting the naphthenic acids into the more easily purified naphthene amines already mentioned at the beginning, that the lowest boiling naphthenic acids (with 6 or 7 carbon atoms) belong to the aliphatic series and have the constitution $C_nH_{2n}O_2$. This conclusion had been reached by Tachitschibabin [76, 1932]. Secondly, those with medium high boiling-points (with 8 to 12 carbon atoms) have the composition $C_nH_{2n-2}O_2$, and possess 1 carbon ring in their molecule; and finally, that the acids with more than 12 carbon atoms have the general formula $C_nH_{2n-2}O_2$ and accordingly must possess 2 carbon rings. These results were first obtained with acids from Nienhagen (Germany), Roumania, and California [6, 1931]. Later, according to some unpublished experiments they were found in acids from Wietze (Germany), Venezuela, Baku, and from a Japanese source (Akita crude oil), as well as from a petroleum poor in paraffins, from Krosno (Poland). Only when the acids are obtained from oils rich in paraffins are the bicyclic representatives missing. Paraffin carboxylic acids, however, appear as impurities in the whole range of monocyclic acids, even amongst the highest members. This fact, which was ascertained earlier with acids from Borys-

law in Poland [6, 1931], was verified with Polish acids from Urycz, according to some unpublished experiments. The Pennsylvanian acids, which are tempting from an investigator's point of view, have unfortunately not yet been obtainable in sufficient quantity for experimental purposes.

The second observation made by the author concerned the union of the carboxyl group to the molecule. This is not a secondary group, but, as mentioned previously, the imide chloride reaction showed it to be predominantly a primary group, i.e. most naphthenic acids contain the grouping $-CH_2COOH$ and only very few the grouping $=CH\cdot COOH$, or $C\cdot COOH$. The carboxyl group must therefore be attached chiefly to a side chain which in turn is attached to a carbon nucleus more or less heavily substituted with alkyl radicals. This knowledge opened up at once the prospect of applying new degrading reactions to determine the constitution of the naphthenic acids and for separating the isomers. With reference to this separation it should be mentioned at the start that in the author's experiments other derivatives of the naphthenic acids as well as the amides (e.g. the ureides) showed themselves to be unsuitable for working up pure individual members of mixtures, and that also the slightly differing solubilities of the acids in sulphur dioxide did not give a sufficient basis for the separation of the isomers (v. Braun and Wittmeyer [10, 1934]). Regarding the degradation, it was found possible to carry it out essentially by methods which allowed of the removal of (I) 4 carbon atoms, (II) 1 carbon atom, and (III) 2 carbon atoms, from the naphthenic acid molecule. These methods depend on the following:

(I) If an acid $R\cdot CH_2COOH$ in which there are at least two more $-CH_2$ groups behind the first one



be converted by way of the brominated acid $R\cdot CH_2\cdot CH_2\cdot CHBr\cdot COOH$

into the α - β unsaturated acid $R\cdot CH_2\cdot CH=CH\cdot COOH$, then this is converted with concentrated sulphuric acid by way of the β - γ unsaturated acid $R\cdot CH=CH\cdot CH_2\cdot COOH$ into the γ -lactone $R\cdot CH\cdot CH_2\cdot CH_2\cdot CO\cdot O$, which itself

yields succinic acid on oxidation. If succinic acid can be obtained in this way, therefore, it is an indication that the molecules with the grouping $-(CH_2)_nCOOH$ are present in the isomeric naphthenic acid mixture. This proof has actually been forthcoming for various naphthenic acids, but from a quantitative point of view not much information is given by this reaction, since the oxidation does not as a rule take place easily; the formation of the α - β unsaturated acid is, as mentioned before, incomplete, and we have no knowledge of the constitution of that part of the acid mixture which is not converted into γ -lactone.

(II) a. If an acid (A) $R\cdot CH_2\cdot COOH$ be degraded by way of the brominated acid chloride ($R\cdot CHBr\cdot COCl$) and azide ($R\cdot CHBr\cdot CON_3$) to the amine $R\cdot CHBr\cdot NH_2$ and this be hydrolysed, an aldehyde results ($R\cdot CHO$) which can be easily oxidized to the next lower acid

$R\cdot COOH$; and an acid (B) $RCH\cdot COOH$ yields, on the other hand, by way of $RCHBr\cdot CO$, a ketone $RCO\cdot O$ which has also 1 carbon atom less than the initial acid (v. Braun [7, 1934]). Mixtures of isomeric acids of types (A) and (B) can therefore be resolved into ketones, which can be further investigated by themselves and acids of lower molecular weight which can be submitted to a further degradation. The

method has not yet been applied in many cases, though it appears to be very valuable.

b. If the mixture of acids

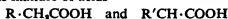

be converted by way of the esters and alcohols into a mixture of the bromides $R \cdot CH_2 \cdot CH_2 \cdot Br$ and $R'CH \cdot CH_2 \cdot Br$, and then by means of trimethylamine into a mixture of the quaternary bromides $R \cdot CH_2CH_2N(CH_3)_3Br$ and $R'CH \cdot CH_2 \cdot N(CH_3)_3Br$, the mixture of the corresponding bases can be converted by A. W. Hofmann's method (after the addition of alkali) into a mixture of the olefines $R \cdot CH=CH_2$ and $R'C=CH_2$. This can then be oxidized to an easily separable mixture of acids $R \cdot COOH$ and ketones $R' \cdot C=O$, just as under *Ila*. The method is rather inconvenient on account of the many single operations involved.

(III) The most convenient, and therefore the most often used method, is that which allows of the elimination of 2 carbon atoms at the same time. An isomeric acid mixture



and



after conversion with azoic acid into the corresponding amine mixture and exhaustive methylation with subsequent breaking down of the product by A. W. Hofmann's method, yields a mixture of isomeric olefines:

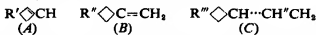

This can be converted by oxidation into an easily separable mixture of monocarboxylic acids $R \diamond CH \cdot CO_2H$, ketones $R \diamond C=O$, and dicarboxylic acids or keto-carboxylic acids (from *A*) with the same number of carbon atoms. The compounds from *A* play no important part, whereas those from *B* and *C* are very important. The former present the possibility of a separation into perfectly homogeneous individual substances through their crystalline derivatives, of which the semicarbazones have shown themselves to be the most suitable, while the latter, by repeating the various operations, can be further converted to a point where the ketones appear. Here also the carbon nucleus is gradually stripped. Of the more general results found so far in this way, the following may be emphasized.

1. It has not yet been possible to isolate in a pure state all the constituents of a ketone mixture obtained by the degradation; as a rule that is only successfully accomplished with one or two components. If, however, such a degradation product is successfully isolated from a naphthenic acid mixture of one particular origin, it can also be isolated from naphthenic acids of similar composition of any other origin whatever. Therefore, one and the same ketone $C_7H_{14}=C:O$ with a semicarbazone melting at $162^\circ C$. has been obtained from all naphthenic acid mixtures of the formula $C_{10}H_{18}O_2$, the same bicyclic ketone $C_{11}H_{16}O$ with semicarbazone of melting-point $169^\circ C$. has been obtained from all bicyclic acids with the formula $C_{13}H_{20}O_2$, and the same ketone $C_{12}H_{20}O$ has been obtained from all acids $C_{15}H_{24}O_2$. This shows that at least some constituents in all naphthenic acids of every source are the same.

2. It was repeatedly found that an acid which had lost 2 carbon atoms by a degradation according to method (III) gave on a second degradation the same ketone as could be obtained from an acid originally 2 carbon atoms poorer, or by a third degradation gave the same ketone as a natural acid 4 carbon atoms poorer would yield. This proves that such acids stand together in the relation $RCH \cdot CH_2COOH$, $RCH(CH_2)_n \cdot COOH$, $RCH(CH_2)_n \cdot COOH$, i.e. that in the

naphthenic acids the phenomenon of chain homology is apparent.

3. If the constitution of a ketone resulting from a degradation has been ascertained, and if the number of degrading reactions according to (III) is known which lead from an acid to a ketone, then the constitution of the acid is also known. This determination of the constitution has been carried only to a modest degree: with the simplest ketone $C_{11}H_{16}O$ it was only possible to ascertain [7, 1934] that it was not identical with dicyclopentylketone

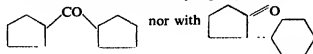

and was probably built similarly to camphor or fenchone; with the ketone $C_{13}H_{20}O$ obtained by a single degradation of the open Polish acid $C_{15}H_{26}O_2$, it was possible to show that it was certainly very similar to the undecylmethylketone $CH_2(CH_2)_{10}CO \cdot CH_3$ but was still slightly different. With the ketone $C_{10}H_{16}O$ from the Polish acid $C_{13}H_{24}O_2$, octylmethyl ketone however, it was possible to show that it was identical with $CH_2(CH_2)_7CO \cdot CH_3$ and that the acid therefore must correspond to the formula



(Friedmelt [26, 1933]). Further, it was possible to prove (v. Braun, Mannes, and Reuter [9a, 1933]) that the ketone $C_8H_{14}O$ with the semi-carbazone melting at $162^\circ C$. possesses the formula

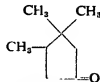

and therefore that all the acids $C_nH_{2n-2}O_2$ out of which it could be obtained by degrading one or more times by method (III), correspond to the formula

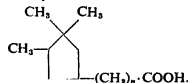

On the basis of this knowledge it was easy to build up the simplest of these acids

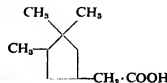

from the trimethylcyclo-pentanone with the help of the Reformatsky reaction, and so to obtain artificially, for the first time, a completely homogeneous naphthenic acid (v. Braun, Mannes, and Reuter [9a, 1933]). It will probably only be a question of procuring sufficient quantities of material and of applying sufficient perseverance in order to make clear the construction of numerous other naphthenic acids, and perhaps also to synthesize them with the help of their degradation products. Meanwhile, it is only possible to say about the constitution that we are evidently only concerned with compounds $R(CH_2)_n \cdot COOH$ (apart from small quantities of normal and branched chain fatty acids), where *R* is more or less highly alkylated 5-ring or a double carbon ring, and *n* = 0, 1, 2, 3, 4, 5, or sometimes even more. From the quantitative study of degradation by

method (III), it follows that compounds with $n = 1$ predominate and those with $n = 0$ are in a very small minority.

One practical application of the experiments and conversions carried out with the naphthenic acids is given in regard to the question of their origin. This question was long disputed: it was not really certain whether the acids pre-existed in the oil, or whether they were formed in one of the processes of refining, particularly during the treatment of the crude oil with concentrated sulphuric acid, when sulphur dioxide is evolved, or by oxidation during the treatment with alkali. Tanaka and Nagai [75, 1926] demonstrated not very long ago that the sulphuric acid wash did not produce any naphthenic acids, at least with Japanese oil. Nishiyama oil, both before and after treatment with sulphuric acid, gave both qualitatively and quantitatively the same naphthenic acids on extraction with alkali. The question of their formation during the alkali treatment could not be decided with complete certainty in laboratory experiments, because of the smallness of the amounts in which they are probably formed. Under these circumstances the following method was adopted by the author (v. Braun and Wittmeyer [10, 1934]). A Californian kerosine fraction was extracted with liquid sulphur dioxide, and the extract (E) containing the unstable, easily oxidizable hydrocarbons, as well as the residue (R) containing the more stably built and less easily oxidized hydrocarbons, were further extracted with alkali. The acids from (R) contained, besides lower boiling acids (110–90° C. at 14 mm.), some with higher boiling-point (to 225° C. at 14 mm.), while the acids from (E) contained only those boiling up to 190° C. at 14 mm. That was, however, the only difference, which is incidentally explained by the solubility relations of naphthenic acids in sulphur dioxide, mentioned previously. Otherwise the acids found in (E) and (R) showed on degradation no appreciable difference as regards quantity and quality. This makes the likelihood of their formation from constituents of the petroleum, which are, of course, different in (E) and (R), very improbable. A further point is whether the naphthenic acids isolated from distilled and undistilled crude oil are the same. This question has been closely examined with Roumanian material by the author [6, 1931], who found that in the acids from crude oil the lower boiling members of low molecular weight which are obtained on working up the distillates are missing, but that the remaining medium and higher acids can be obtained in both cases with equal properties. v. Pilat and Reyman [54, 1932] came to a similar result respecting the acids of medium molecular weight from distilled and undistilled Polish petroleum. They converted the acids from both sources, R·COOH by way of the esters, alcohols, and bromides (R·CH₂·Br), and malonic ester condensation products, R·CH₂·CH(COOC₂H₅)₂, into

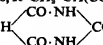
barbituric acids R·CH₂CH  COO, which they

found in both cases to be in very good conformity with each other. One may, therefore, probably assume that by the distillation of crude oil the greater part of the naphthenic acids remain unchanged. Probably only those of high molecular weight suffer a far-reaching disintegration into substances of very small molecules, in a similar manner to the phenols from petroleum, previously mentioned. The opinion expressed recently by Pyhäälä [60, 1933]—that the naphthenic acids are formed out of other oxy-compounds by thermal decomposition during the distillation of the crude oil—is probably erroneous.

It is of importance that the researches into the separation, degradation, and determination of the constitution of the naphthenic acids be continued, since they are of great value in the scientific investigation of petroleum. This will be particularly the case when once individual naphthenic acids R·COOH of well-recognized construction can be obtained successfully in quantity, and these converted either by decarboxylation, which has so far presented great difficulties, or, according to Komppa and Zelinsky, by way of the esters and alcohols R·CH₂OH, into the many hydrocarbons R·H· and R·CH₂ of mono- and bicyclic type which correspond to the acids. From this artificial material a great many observations of importance for the chemistry of petroleum will be obtainable. Further, progressive examination of the naphthenic acids will be of importance in regard to their technical application. Thus in the domain of perfumes it may be possible to find which particular structure among the acids of medium molecular weight gives the best smelling primary alcohol; in the domain of the wetting agents we may be able to recognize which structural conditions bring about the best wetting properties after esterification with glycerol; and in the realm of medicine we may be able to find those acids R·COOH which produce especially good sleep-inducing effects after conversion into barbituric acids of the type

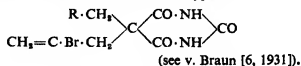

The technical applications of the naphthenic acids so far discovered rest purely on empiricism. They have been repeatedly mentioned in this article, and here only a brief summary of their further uses need be given. Free naphthenic acids are used in the same way as naphthene sulphonic acids, in order to destroy water-petroleum emulsions (Pyhäälä [59, 1930]); to retard the gelatinization of wood oil on heating (Vernisoli [78, 1912]); to dissolve and regenerate rubber (Cherchovsky [18, 1908], Kinney [37, 1931]); to reduce in many cases the viscosity of colloidal solutions (Petit [51, 1929]). Further, they are used as a constituent of insecticides (I.G. Farbenindustrie [33, 1927], Merrill [48, 1928]) and to produce oil- and grease-soluble colours by the action on basic dyes (Chem. Fabrik, Worms [16, 1926]). Esters of the naphthenic acids are used for the preparation of plastic masses or of lacquers (I.G. Farben. [35, 1929], Deutsche Hydrierwerke [20, 1931]), and the alcohols are used in the production of wetting agents and detergents. Much more important are the uses of the salts of the naphthenic acids, of which the sodium salts in particular serve as a cheap substitute for soap. They can also be used to increase the viscosity and lubricating power of oils (Standard Development Co. [69, 1925], Rüdiger [62, 1930], White and Knopf [79, 1931]), and have been found to be useful in stabilizing the emulsions of various water-insoluble substances (Simon and Dürckheim [66, 1918], Pree [57, 1931], Hack [30, 1929], Frizell, Stagner, and Union Oil Co. [27], Mackay [42, 1925], Sautermeister and Stauss [63, 1925]). Lithium salts are said to be readily absorbed and to have a good curative effect on gout (Chlorit Chem. Fabrik [18, 1925]), while the salts of zinc, cobalt, lead, chromium, iron, aluminium, bismuth, arsenic, antimony are prepared in various forms for the manufacture of stopping compounds, paints, insulating materials, artificial leather, and siccatives, or for the preservation of wood (see the detailed summary of the patents in the works

of Carleton Ellis [24, 1934], pp. 1088-91, and Naphtali, Naphtensäuren und Naphtensulphosäuren, Nachtrag, 1927-33, p. 35 [50]). Of the organic amines, mono-, di-, and tri-ethanol amines have been applied in combination with naphthenic acids for the production of salts with strong wetting and emulsifying properties (I.G. Farben. [34, 1929]).

In conclusion an important question may be put forward: whether it is possible to prepare, artificially, naphthenic acids from the naphthene hydrocarbons. It has occasionally been supposed that such a transformation has taken place in nature (e.g. under the action of steam), but it has by no means been proved. In laboratory experiments the oxidation of crude oil and of separate fractions of oil distillates has already been examined from very many directions; the method of oxidation most exactly investigated has been that by molecular atmospheric oxidation. The most detailed experiments are those by Charitschkov [15, 1908 and 1909], who examined the acid products thus produced, but it is not possible to draw perfectly clear conclusions from his results. There seems to be no doubt

that the oxidation takes place in part by the union of molecules with loss of hydrogen, and then by the entry of oxygen complicated acids are formed which are termed 'Polynaphthenic acids' or, since they readily change into asphaltic substances, 'Asphaltogenic acids'. Their nature and constitution are still unknown. Whether the small quantities of acids of low molecular weight which are formed at the same time correspond exactly to the naphthenic acids is not yet definite. An answer to these questions would be of the utmost interest. The investigation would most appropriately need to start from the simplest possible mixture of such hydrocarbons, prepared according to Komppa and Zelinsky, from the naphthenic acids by way of the corresponding alcohols, in order to see whether these hydrocarbons could be oxidized back again into the original acids.

The whole question of the probable origin of the naphthenic acids in the naphthenes presents, in any case, a particularly important chapter in the realm of petroleum constituents.

REFERENCES

- ALBRECHT, R. Dissertation Karlsruhe 1907. *Chem. Rev. Fett- u. Harz-Industrie*, 18, 153, 189 (1911).
- ALLEMAN, G. U.S.P. 1,694,461 (1928).
- ASCHAN, C. *Ber.* 23, 871 (1890).
- *Ber.* 24, 2714 (1891).
- ASCHHEIM, S., and HOHLWEG, W. *Deutsch. Med. Wschr.* 59, 12 (1933).
- V. BRAUN, J. *Lieb. Ann.* 490, 100 (1931).
- *Ber.* 67, 218 (1934).
- *Ber.* 66, 684 (1933).
- V. BRAUN, J., JOSTES, F., and MÜNCH, W. *Lieb. Ann.* 453, 113 (1927).
- V. BRAUN, J., MÄNNES, L., and REUTER, M. *Ber.* 66, 1499 (1933).
- V. BRAUN, J., and WITTMAYER, H. *Ber.* 67, 1739 (1934).
- BREDA, H. B.P. 19,477 (1906).
- BUDOWSKI, J. *Die Naphthenäuren*. Berlin, 1922.
- BUSHONG, F. W., and HUMPHREY, S. *Intern. Kongress f. angew. Chemie*, 6, 57 (1912).
- CHARITSCHKOV, K. *J. russ. phys. chem. Soc.* 29, 691 (1897); *Chem. Centralblatt*, 1898, 1, 1191.
- *J. russ. phys. chem. Soc.* 40, 1757 (1908); 41, 345 (1909).
- Chem. Fabriken Worms A.G. B.P. 151,657 (1920); G.P. 424,194 (1926).
- CHEHCHEWSKY, N. G.P. 218,225 (1908).
- Chlorit Chem. Fabrik A.G. G.P. 404,697 (1925).
- Deutsche Hydrierwerke A.G. B.P. 369,301 (1931); B.P. 396,311 (1932); G.P. 552,535 (1932).
- B.P. 390,534 (1931).
- DIETSCHKE, O. Dissertation, Tübingen, 1922.
- FRANGOPOL, D. Dissertation, München, 1910.
- EICHLER. *Bull. Soc. Nat. de Moscou*, 46, 274 (1874).
- ELLIS, CARLETON. *The Chemistry of Petroleum Derivatives*, New York, 1934.
- Erdölverwertungsgesellschaft. G.P. 305,771 (1916).
- FRIEHELM, E. Dissertation, Frankfurt a. M., 1933.
- FRIEDEL, R., STAGNER, R. A. Union Oil Company of California. U.S.P. 1,582,257, 1922.
- GOLDBERG, D., SCHIWARDOWA, E., and MARUMJAN, W. *Azerbaidzhanokole dafjanole Chosjajstwo*, 14, 72 (1934); *Chem. Zentr.* 2, 3465 (1934).
- GURWITSCH, L., and MOORE, H. *The Scientific Principles of Petroleum Technology*. London 1932.
- HACK, E. B. Austral. P. 21,709 (1930).
- HELL, C., and MEIDINGER, E. *Ber.* 7, 1216 (1874).
- HOLZMANN, E., and V. PILAT, S. *Brenn-Chem.*, 11, 409 (1930).
- I.G. Farbenindustrie A.G. G.P. 417,004 (1923); 433,683 (1927); 509,086 (1930); 526,179 (1927).
- B.P. 309,842 (1929).
- B.P. 351,945 (1929).
- IPATIEV, W., and PETROW, A. *Ber.* 63, 329 (1930).
- KINNEY, A. M. U.S.P. 1,815,778 (1931).
- KOMPPA, G. *Ber.* 62, 1562 (1929).
- KRÄMER, G. *Chem. Ztg.*, 675, 1907.
- KRÄMER, G., and BÖTTCHER, W. *Ber.* 20, 596 (1887).
- KUPZIS, J. *Chem. Centralblatt*, 1, 1170, 1902.
- MACKAY, H. A. B.P. 233,784 (1925).
- MARCUSSON, J. *Chem. Ztg.*, 581, 1915; *Mittell. aus d. Mat. Prüf. Amt*, 374, 1917; *Petr. Z.*, 12, 1149.
- *Mittell. aus d. Mat. Prüf. Amt*, 308, 1922.
- MAROVNIKOV, W. *Lieb. Ann.* 307, 335 (1899).
- MAROVNIKOV, W., and OULOBIN, W. *J. russ. phys. chem. Soc.* 13, 34 (1883).
- MERKEL, M. Dissertation, Tübingen, 1915.
- MERRILL, D. R. U.S.P. 1,695,197 (1928).
- NAPHTALI, M. *Chemie, Technologie und Analyse der Naphthenäuren*. Stuttgart, 1927.
- *Naphthenäuren und Naphtensulphosäuren*. Stuttgart, 1934.
- PETTI, F.P. 686,880 (1929).
- V. PILAT, S., and HOLZMANN, E. *Brenn-chem.*, 12, 41 (1931).
- V. PILAT, S., and V. KOZICKI, G. *Petr. Z.*, 11, 310 (1915).
- V. PILAT, S., and REYMAN, J. *Lieb. Ann.* 499, 76 (1932).
- V. PILAT, S., and SEREDA, J. *Fettschemische Umschau*, 1934, Heft 9.
- POHL, F. G.P. 408,663 (1922).
- FREE, E. G.P. 537,792 (1931).
- PYHÄLÄ, E. *Petr. Z.*, 9, 1373 (1913).
- *Erdöl u. Teer*, 6, 478 (1930).
- *Chem. Ztg.*, 57, 273 (1933).
- ROBINSON, J.S.C.I., 232, 1889.
- RÜDIGER, E. A. U.S.P. 1,750,134 (1930).
- SAUTERMESTER, C., and STAUS, K. G.P. 410,542 (1925).
- SCHMIDT, K. F., and KNOLL, A. G. F.P. 671,388 (1929); G.P. 500,434 (1932).
- SCHWARZ, F., and MARCUSSON, J. *Mittell. aus d. Mat. Prüf. Amt*, 27, 17 (1909).
- SIMON, J., and DÜRCKHEIM, G.P. 309,574 (1918).
- SPALWING, *Chem. Ztg. Rep.*, 196, 1903.
- STADNIKOV, G., and DONDE, *Trans. Karpov. Inst. Chem.*, 1925.
- Standard Development Company. U.S.P. 1,552,669 (1925).
- STIEPEL, C. G.P. 305,702 (1918).
- STORY, G. DE ROY, and SNOW, R. D. *Ind. Eng. Chem.* 20, 359 (1928).
- TANAKA, J. *J. Fac. Eng. Tokyo Imp. Univ.* 13, 41 (1923); 15, 271 (1924); 16, 1 (1924); 17, 171 (1925).
- TANAKA, J., and KOBAYASHI, R. *J. Fac. Eng. Tokyo Imp. Univ.* 17, 127 (1927).
- TANAKA, J., and KUWATA, T. *J. Fac. Eng. Tokyo Imp. Univ.* 17, 293 (1928).
- TANAKA, J., and NAGAI, S. *J. Fac. Eng. Tokyo Imp. Univ.* 16, 183 (1926).
- TECHTSCHIBARIN, A. E. *Chim. et Ind.* 27, 306 (1932); *Chem. Zentr.*, 1932, 1, 952.
- Vereinigte Chem. Werke. G.P. 200,684 (1906).
- VERINSOL. G.P. 253,845 (1912).
- WHITE and KNOPF. U.S.P. 1,789,614 (1931).
- ZELINSKY, N. *Ber.* 57, 42 (1924).
- ZELINSKY, N., and POKROVSKAJA, E. *Ber.* 57, 46 (1924).
- ZELINSKY, N., and RIACHINA, E. *Ber.* 57, 1932 (1924).

GUM IN GASOLINE

By W. A. GRUSE, Ph.D., A.P.I.

Senior Fellow, Mellon Institute of Industrial Research

Introduction

Description.

THE term 'gum' as used in connexion with motor fuel refers to resinous deposits found in the intake systems of gasoline engines or in the containers in which the gasoline is stored. The engine deposits are usually dark in colour, hard, and brittle, while deposits in storage containers are usually soft and sticky; occasionally they are liquid and light in colour. These soft or liquid deposits change on heating to yield the hard, dry products found in engines, so that the conditions of formation explain the differences.

Historical.

The presence of gum in gasoline was apparently first recognized in 1914. In a paper published in that year describing his vapour-phase cracking process, Hall [27, 1914] mentioned the fact that when the gasoline was allowed to stand, a resinous substance with a varnish-like odour separated out. He recognized the connexion of this phenomenon with oxidation, and attributed it correctly to the presence of oxidizable unsaturated hydrocarbons produced by the cracking. He did not, apparently, consider the occurrence of gum as an obstacle to the use of highly cracked gasolines. The Rittman [51, 1916] vapour-phase process was developed about the same time, but apparently no attention was given to the gum content of the product. It is possible that the Rittman material was appreciably more saturated than that made by Hall, since Rittman's pressure for gasoline making was 12 atm., while Hall used a low pressure for cracking; the 5 atm. employed for what we would now call polymerization was not applied until after the cracking stage, when the temperature had dropped a great deal.

The Hall and Rittman processes presumably attracted attention because of a war-time demand for aromatic hydrocarbons as well as for motor fuel. When this demand ceased, interest in high-temperature cracking processes fell away and did not revive for 7 or 8 years. In the meantime, tetraethyl lead was discovered and made available; gradually a demand for anti-knock gasoline made itself felt. Petroleum refiners discovered that by cracking at higher temperatures and by cracking naphthenic or already cracked stocks, gasolines of high anti-knock value could be made. But these gasolines were high in gum content and required rather heavy chemical treatment. This was about 1925. The gradual rise in cracking temperature finally led to a rediscovery of vapour-phase cracking, with the production of gasolines so high in gum that they could not be used satisfactorily in undiluted form, even after drastic refining. This was partly corrected by raising the pressure prevailing on the cracking systems.

While low-pressure vapour-phase cracking has been developed to only a limited extent, the recent trend has involved gradual increase of temperature without lowering the pressure, so that the gap between the two types of operation has been narrowed and almost closed. The gasolines so made are definitely subject to gum trouble, but satisfactory chemical means of preventing gum formation have been developed. This is discussed below.

In the meantime (1924), and independently, the formation of resin deposits in engines using motor benzol as fuel attracted attention in England, and investigations were undertaken which have been presented as a series of reports of the Joint Research Committee of the National Benzole Association and the University of Leeds [32, 1924-30]. In spite of some differences the phenomena involved are closely related to those occurring with gasoline, and it is interesting to note that the methods discovered for avoiding gum trouble in the two cases are essentially the same.

Practical Significance.

The significance of a high gum content in gasoline is very real and definite. Direct experiments have shown that a fuel high in gum cannot satisfactorily be used in a gasoline engine. At the same time the reduction of gum content in cracked gasoline requires expensive treating, volume loss, and sometimes loss in anti-knock value. The prevention of gum development is the most satisfactory remedy.

Gum Formation

Nature of Process.

So far as known there are no cases of appreciable gum formation in gasolines which have not been exposed to chemical, usually thermal, decomposition. Straight-run gasoline (that produced by normal non-destructive distillation of crude oil) is essentially gum free. Cracked gasolines show a gum content which varies more or less directly with the extent of the cracking, or, in general, with the temperature at which the cracking has occurred. Motor benzoils are made in a process which is essentially a high-temperature cracking and, as might be expected, show definite gumming phenomena. Since cracking of hydrocarbons and coal produces unsaturated compounds, and since these latter are readily oxidized, it is not difficult to find a connexion between gum formation and the oxidation of the unstable hydrocarbons in a cracked product. There had never been much doubt about this in the minds of investigators concerned with the problem (Hill and Dean, [29, 1920]), and it was brought out very clearly in the investigations by Smith and Cooke [57, 1922]. Prior to this, Brooks and Humphrey [7, 1918] had referred to diolefines as responsible for the resinification of highly cracked gasolines after standing several months. The copper-dish gum test has been applied to the gasolines collected in the U.S. Bureau of Mines Gasoline Survey of 1919 (Hill and Dean [15, 1919; 29, 1920]); it is interesting to note that at that early date 30% of the 850 samples collected in the United States showed over 30 mg. of deposit per 100 c.c. by this test. Smith and Cooke made exploratory experiments involving evaporation of cracked gasoline in presence of air and hydrogen, storage in presence and absence of air, the recognition of an 18% oxygen content in certain gums, and similar variations which made quite evident the role of oxidation in causing large gum deposits. They did not offer proof that oxidation is at the bottom of all gum deposition, but they suggested the oxidation of unsaturated hydrocarbons, produced by cracking, to aldehydes as the starting-point for gum formation. They

entertained the intriguing possibility that gum was material of the aldehyde-phenol condensation type, but dropped it after finding that the necessary phenol content was not on hand.

The general idea that formation of resins from unsaturated petroleum oils is analogous to the oxidation of turpentine was also expressed about this time by Brooks [5, 1922]. Experiments on the influence of the surrounding atmosphere on the proportion of gum formed from a gasoline were made by Cooke [13, 1925] who developed the first method of determining gum actually present in gasoline at the time of test, independent of any oxidation during the test. This was the Cooke steam-oven procedure in which gasoline was evaporated in an atmosphere of steam. More definite evidence was presented much later by Story, Provine, and Bennett [62, 1929] who found that the same gasoline gave different proportions of deposit as follows:

Atm.	Natural gas	Steam	Air	Oxygen
Gum, mg. per 100 c.c.	27	34	394	526

They showed the formation of typical gums by oxidation of cracked gasoline under controlled conditions, and Voorhees and Eisinger [65, 1929] did the same thing at about the same time.

Chemical Characteristics of Gum.

As stated above, gum is known in two connexions, very occasionally as a brownish-black, brittle, rather hard resin in the intake systems of gasoline engines using highly cracked gasoline, and more frequently as a deposit in storage vessels or testing equipment employed for cracked gasoline. The latter material varies from a mobile liquid to a hard solid and in colour from an extremely pale yellow to the same brown-to-black colour noted with engine deposits.

Storage practically always yields liquid to soft semi-solid deposits; colour and consistency commonly increase together. The liquid deposits are light coloured and the semi-solids are usually dark. Where much deposit is formed it is very likely to be liquid; the scantier deposits are more resinous. The hard formations are practically always associated with a heating step. Thus most gums found in testing are relatively soft before drying in a hot oven or by a hot air stream. The gum removed from engines is known only in its final hard, brittle, dark-coloured form, but it is a fair assumption that it comes down from the gasoline mixtures in a soft condition and changes to a progressively harder product as it is baked on the hot engine surfaces. We may then tabulate the kind of gum normally encountered, as follows:

- (a) From storage:
 1. Light coloured liquids (often viscous).
 2. Brown to dark semi-solid.
- (b) From testing equipment:
 1. Yellow-brown liquids from prolonged oxidation by air or oxygen at temperatures not much above 100° C.
 2. Brown to black, hard, normally brittle solids produced by tests which require a prolonged or high-temperature heating or drying step.
- (c) From engine parts:
 1. Hard, brittle, dark-coloured resins. They occur on intake valve parts and in intake manifold systems.

As a matter of observation, it seems that liquid deposits are associated with extensive oxidation under conditions which provide plenty of air or oxygen. Where air supply is restricted, the deposit is more nearly solid. The fact that heating and drying convert the soft materials into hard, dark solids has been amply confirmed, as has also the fact that this change is often accompanied by rather violent decomposition of unstable compounds in the deposits. Even vacuum distillation with only low temperature does not entirely prevent marked chemical change. The solid resin from a liquid deposit varies from 20 to 50 or 60% of the original.

The empirical composition of a liquid deposit produced by free-air oxidation of a cracked gasoline stored in glass and exposed to daylight, of a resin produced from this liquid by drying, and of a gum formed by evaporation in copper dishes on a steam bath are given by Story, Provine, and Bennett [62, 1929] as follows:

	Liquid gum	Dried liquid gum	Copper dish gum
Per cent.	100	54.4	100
Carbon	64.97	71.95	70.73
Hydrogen	8.56	7.99	6.95
Oxygen	26.08	19.48	19.51
Nitrogen	0.13
Sulphur	0.22	0.33	0.68
Ash	0.17	0.25	2.00*
Iodine no. (Hanus)	47	95	73
Sapon. equiv.	289	144	191
Neutralization equivalent	625	651	732
Mol. wt.	172	338	200
M.P., °C.	..	68-71	98-105
Consistency	dark-brown viscous liquid, sp. gr. 1.0932	brown resinous solid	dark-brown resinous solid

* Mostly dust.

Gum residues from cracked gasolines which had been oxidized under oxygen pressure have been analysed by Morrell, Dryer, Lowry, and Egloff [44, 1936] with the following results:

	Pennsylvania	West Texas	California
Carbon %	69.6	74.9	76.2
Hydrogen %	9.2	9.4	10.6
Sulphur %	0.42	0.44	2.91
Oxygen (by difference) %	20.8	15.3	10.3
Mol. wt.	342	236	210

It is difficult to get very far with figures like the above without taking into account the chemistry involved in the formation of the material. The data show that the oxygen content is high, saponifiable material relatively low, and the acidity quite high; the molecular weights are only moderate. It is not safe to draw any conclusions from the change in composition with drying, since both evaporation and chemical change are involved. Any sulphur compounds present in the gasoline are likely to be involved, but information is lacking.

Chemistry of Gum Formation

For pioneering on the chemistry of gum and gum formation we are indebted to significant observations and discussions by Brooks [6, 1926] and to an excellent investigation by Story, Provine, and Bennett [62, 1929]. Brooks points out that gum is obviously connected with the formation of oxidation products from unsaturated

hydrocarbons, and calls attention to the isolation of peroxides from simple olefines upon autoxidation by Engler and Weisberg [23, 1900], and from cyclic diolefines by Thiele [63, 1920] and by Stobbe [61, 1919]. Since cracked gasoline is high in olefinic compounds and the condition for natural gum formation is essentially one of autoxidation, it would seem that peroxide formation is perhaps the first step in gum production. When it is noted that fresh gums, naturally formed, decompose on heating in about the same way as do peroxides, the probability becomes greater. The content of acidic material increases with age, and the solubility in dilute alkali increases. A typical resin contained

30% water soluble,
30% neutral,
40% soluble in 3% alkali solution.

The neutral material consisted of aldehydes and ketones, and the water-soluble constituents might be either neutral or acidic, but of low molecular weight. The gasoline from which gum was separated contained aldehydes and ketones recoverable by bisulphite additions; formaldehyde was noted when an aged sample of cracked gasoline was distilled. Aldehydes are not, however, the first products of gasoline oxidation. Peroxides can be detected in cracked gasoline after half an hour of exposure to air and sunlight, and it is from these that the aldehydes are derived. There is fair evidence that gum is not derived from aldehydes by the ordinary condensation reactions. For one thing an alkaline medium is required, whereas the oxidation process for cracked gasoline normally produces an acid system. Furthermore, the gum itself is an acid product, soluble in dilute alkali, which is not true of ordinary aldehyde condensation resins. The decomposition of some peroxides by water is well established; water treatment is shown to reduce the amount of gum formed from an oxidized cracked gasoline. The oxidation of stable hydrocarbons is promoted by the presence of small proportions of readily oxidizable hydrocarbons, and direct experiment shows that small additions of limonene increase largely the amount of gum obtained from cracked gasoline; this phenomenon is apparently to be attributed to the catalytic influence of the peroxides of the unstable hydrocarbons. The conversion of peroxides into aldehydes and ketones is generally regarded as an ordinary one, but the mechanism by which it occurs is somewhat obscure. Brooks [6, 1926] has called attention to the Prileschaev reaction [7, 1918], which involves the oxidation of olefines by peroxides to yield alkylene oxides, which in presence of water and weak acid are converted to aldehydes and ketones.

The conclusions, from the study by Brooks, roughly summarized above, are that unstable cyclic olefines and diolefines oxidize very readily to form peroxides; that these catalyze the oxidation of other hydrocarbons such as simple olefines which by themselves resist such oxidation; that the peroxides decompose by a mechanism suggested, to yield aldehydes, ketones, and acids of low and high molecular weight; that the acids of high molecular weight resemble those formed by similar atmospheric oxidation of turpentine and constitute the non-volatile resinous material known as gum.

The work of Story, Provine, and Bennett [62, 1929] which came three years later leads to much the same conclusions, but brings out additional interesting points. It is directed largely to the gum which is produced under test conditions. The influence of the atmosphere prevailing during the test

was established (mentioned above). The type of dish employed for evaporation was examined, and the promoting action of copper dishes and of copper oxide placed in a glass dish was demonstrated; a small addition of copper oxide increased the gum deposit tenfold. It was shown that a slow evaporation yielded more gum than a rapid one, because more time was allowed for oxidation. Quantitative tests showed that peroxides and aldehydes were formed early during evaporation, and acids as end products. The increase of acid during evaporation was demonstrated, as was the absence of peroxide and acid during evaporation of refined gasoline (sulphuric acid treatment). Incidentally, practically no gum was recovered from this refined gasoline. The figures showed that acidity increased quite rapidly during the latter part of the evaporation of the cracked product, and the suggestion was offered that this occurred because the less volatile compounds began oxidizing at this stage, particularly in the presence of copper. As gum increased the amount of acidic material increased, in such a way as to indicate that the gum was mostly acidic, some of it as anhydrides or lactones. The gum formed in copper-dish evaporation was examined and found to be more than half water-insoluble acids, almost a third water-soluble acids, and only 13% unsaponifiable. The viscous, sticky liquid deposit collected (in the amount of about 15% as a maximum after 4 months) from cracked gasoline exposed to light and free access of air, was analysed similarly. The figures are given on p. 1017 of this article. This product gave no test for peroxides and only faint tests for aldehydes and ketones. These latter, however, appeared in the volatile material set free by saponification. Water-soluble and water-insoluble acids, in the amount of 33 and 38% respectively of the whole, were isolated, together with 6% of acids volatile with steam. The remainder, about one-fifth of the whole, was unsaponifiable, and was presumably mostly aldehydes and ketones. The gasoline from which the gum had separated was extracted with alkali and the dissolved materials precipitated in fractions by incremental neutralization. Typical solid acids, a phenolic fraction, and finally a liquid acid were obtained in succession. Acetic and acrylic acids were identified, and the remaining products seemed to be higher unsaturated acids.

The importance of peroxides in the oxidation process was indicated by observations that in gasoline exposed to sunlight and air the peroxide content rose with a period of sunshine and decreased during darkness or cloudy periods. Absorption of oxygen continued during such periods, but at the expense of the peroxide oxygen. An apparatus in which oxygen was metered into a volume of cracked gasoline at room temperature and exposed to daylight made possible the observation of an induction period, at the end of which gum began to separate and carbon dioxide to be given off. From this point on the direct connexion between oxygen absorbed, gum content, and acidity developed was very striking. The dependence of rapid peroxide development on sunlight rather than upon oxygen was shown by experiments on a gasoline in which

sunlight + oxygen
dark + oxygen and
sunlight without oxygen

were compared. In the first case and within 36 hours peroxide formation was large, and in the third case small; but in the second case it amounted only to traces.

At about the same time that Story, Provine, and Bennett

[62, 1929] published the above work, Voorhees and Eisinger [65, 1929] introduced the concepts of preformed gum and potential gum. The former is that existing in a gasoline at any one time in its history, and the latter is the amount of gum which may form during a long period of storage. The former corresponds more or less to the 'steam-oven' gum determined in the test devised by Cooke [13, 1925] and the latter they determined by an application of the fact developed independently by Story, Provine, and Bennett; a cracked gasoline was exposed to oxidation from a measured supply of oxygen supplied under slight pressure. The vessel containing the gasoline was shaken to produce agitation and was heated to steam-bath temperature; by these means the oxidation was accelerated. At the end of 5 hr. the oxidized gasoline was evaporated in an atmosphere of steam and the residual gum was determined by weighing. Voorhees and Eisinger [65, 1929] made highly significant engine tests on gum deposits, which are discussed below, and brought out the fact that it is the preformed or actual gum developed in a gasoline which governs the amount of deposit to be expected in an engine; the potential gum, which depends on the proportion of constituents oxidizable to gum, appears from this work to be of no significance in this regard.

In the following year a notable contribution to the subject was made by Hunn, Fischer, and Blackwood [31, 1930]. They confirmed the statement of Voorhees and Eisinger that dissolved or preformed gum is the determining factor in the production of engine trouble from gum deposits, potential gum having no significance in this connexion, and they introduced the accelerated oxidation test which involves heating a sample of gasoline under oxygen pressure at steam temperature, which is now known as the oxygen stability test. In this procedure a sample of gasoline is heated as just indicated, and the length of time elapsing before enough oxygen is absorbed to show a drop of pressure on the recording apparatus is taken as an indication of the length of time the gasoline might be expected to remain in storage before deterioration would begin; this is essentially a measurement of an induction period. Their work is discussed below.

The connexion between gum formation and peroxide content of cracked gasolines was further emphasized by Yule and Wilson [69, 1931]. They showed that by removing peroxides from an oxidized cracked gasoline (reduction with alcoholic ferrous chloride) the gum content as determined by a method roughly equivalent to the Cooke steam-oven test was reduced very strikingly. They confirmed the existence, for most gasolines, of an induction period for oxidation, during which no apparent change occurs. They showed that the induction period can be shortened very greatly by adding peroxides or by extracting the gasoline with caustic solution; the latter process apparently removes natural anti-oxidants, presumably phenols. Yule and Wilson showed some interesting data on the removal of peroxides (and gum) by various reagents, made possible by the developing of an improved test for peroxides, which, however, is still somewhat empirical. Water was shown to have little effect, and heating, particularly in presence of unsaturated hydrocarbons, a large effect in decomposing the types of hydrocarbon peroxides encountered in oxidized gasolines. However, a quick distillation may not decompose all the peroxides present, so that presumably under engine conditions only a part of the gum is formed which might be expected from the peroxide content. The general conclusion from this work

of Yule and Wilson is that in oxidized gasoline the reaction products of oxidation stay in the form of peroxides which do not change to gum until evaporation occurs.

In 1927 Wagner and Hyman [66, 1930] presented data showing the importance of oxidation in gum formation, the existence of an induction period, and the importance of some per-oxidized substances as promoters of gum formation. They differed from other investigators in proposing per-acids rather than peroxides as the promoters, and set up a reaction scheme employing the Prileschaev reaction [48, 1911] to which Brooks [6, 1926] had first called attention. This involved the oxidation by peroxides (in this case per-acids) of olefines, yielding products characterized as alkylene oxides. The matter is discussed below.

In a series of papers Morrell, Dryer, Lowry, and Egloff [43, 1934-5] have presented a considerable volume of data confirmatory of the main point made above and have thrown some interesting light on the whole matter. They note that peroxides can be observed in oxidized cracked gasoline long before any of the other oxidation products are apparent; as they increase largely with time, darkening and gum formation also occur. They note further that aldehydes appear later and increase more gradually than do peroxides. Acids appear later still and increase still more gradually. The increase of gum with time is closely connected with the increase of peroxides with time, and the authors suggest that aldehydes and acids are secondary products, the connexion between gum and peroxides being direct. The gum formed by evaporation from different cracked gasolines was found to show peroxide, aldehyde, and acid in decreasing amounts; the proportions of these in gum from the same gasoline did not change greatly with the extent of oxidation, although the amount of gum did increase. In other words, more extended oxidation simply gave more of the same kind of gum. Their indication that peroxides are the predominant constituents of evaporated gum differs from that of Story, Provine, and Bennett, who found acid in greatest amount in both evaporated and precipitated gum; but in an analysis of a precipitated gum from California gasoline they recognized an extremely high proportion of acid, thus agreeing with Story, Provine, and Bennett. A related paper by Morrell, Benedict, and Egloff [42a, 1936] contains interesting studies on the known influence of light in forming what is known as 'haze' in cracked gasoline. The importance of photochemically induced oxidation in causing this precipitation of insoluble material in fine particles was demonstrated. It did not occur with cracked gasoline, but did with the straight-run product and with blends of straight-run and cracked fuel. The haze was shown to be dependent on the presence in the fuel of sulphur or disulphides, and the occurrence of sulphuric acid in the haze was established. Haze formation is thus related to gum formation, but is not the same phenomenon.

Hydrocarbons responsible for Gum Formation.

On the subject of what particular hydrocarbons in cracked gasoline are responsible for gum formation, there is substantial agreement, but very little experimental evidence, that certain types of unsaturated hydrocarbons are very readily oxidized and that the oxidation products so formed catalyse the oxidation of more stable substances. In a paper presented in 1930, but not published until 1933, Flood, Hladkey, and Edgar [25] showed gum tests on solutions of various pure olefinic hydrocarbons in

highly refined stable gasolines; gum by evaporation, by pressure-bomb oxidation, and by ageing tests were determined. It was concluded that aliphatic and cyclic diolefines and mono- or di-olefines attached to a benzene ring are the compounds mainly responsible for gum formation in gasolines. They noted, however, that 1,5-hexadiene was more stable than other diolefines. This checks the observation of Kogerman [33, 1930] that 1,5-hexadiene did not absorb oxygen during three months at room temperature in an oxygen atmosphere, and that it is the conjugated diolefines which are highly oxidizable. Prior to the publication of the paper by Flood, Hladkey, and Edgar [25, 1933], Cassar [9, 1931] had shown that simple olefines after 4 hours' oxidation at 100° C. under oxygen pressure did not form gum, but that diolefines, unless entirely free of peroxides, did so.

The tests by Flood, Hladkey, and Edgar were at high temperature; oxidation at temperatures approximating those of normal storage were employed in a somewhat different attack on the problem by Martin, Gruse, and Lowy [40, 1933]. A highly unstable vapour-phase gasolene was fractionated carefully into 10° F. cuts. These were subjected to oxidation at 25 and 38° C. under 20 lb. pressure of oxygen for periods of 2 weeks and 1 week respectively, and the gum formed was determined by evaporation in steam. When the gum results were plotted against the boiling-points (see Fig. 2) three peaks in the gum curves were noted, one each corresponding roughly to the boiling-points of a group of conjugated diolefines and cyclic olefines. Typical hydrocarbons for each group are 2,4-cyclohexadiene, b.p. 78.5° C.; 1-methyl-1,3-cyclohexadiene, b.p. 110° C., and 1,3-dimethyl-1,5-cyclohexadiene, b.p. 130° C. Treatment of the gasoline fractions with maleic anhydride, by mild hydrogenation or with sulphuric acid, any one of which would remove diolefines, rendered the fractions stable at 38° C., but oxidation and gum formation proceeded again at 50° C. This would indicate that a cracked gasoline contains a small proportion, probably not more than a per cent. or so, of hydrocarbons, presumably conjugated diolefines, which oxidize readily at ordinary storage temperatures, forming gum. When these are removed the gasoline is stable under the mild conditions of the original test, but at a slightly higher temperature oxidizes again. The probable explanation is that another class of hydrocarbons, say, cyclic monolefines, are attacked under the slightly more severe condition. It is to be assumed that the oxidation is in no case limited to the initiating hydrocarbons, but that induced oxidation begins in compounds of intermediate stability. Cyclohexene did not oxidize in 50% concentration at 38° C., but in the presence of a small amount of oxidized gasoline gave low yield of gum. Di-isobutylene and octane-2 did not oxidize, however, at this temperature, even in presence of oxidized gasoline.

Unpublished portions of the above work from the author's laboratory have indicated that different cracked gasolines show the same gum peaks at the same places on the boiling-point curves, differing only in the amount of gum found; this latter increases with the temperature of the original cracking. In other words, a more highly cracked gasoline forms more gum, but this is presumably because it contains more of the same unstable hydrocarbons responsible for gum in a less cracked gasoline. The autoxidation, to gum-like substances, of conjugated diolefines and the comparative stability of the non-conjugated compounds of the same class, has been brought out clearly

by Kogerman [33, 1930]. In work referred to above it is interesting to note that 2,4-hexadiene and 2-methyl-2,4-pentadiene took up 2 mols of oxygen per pair of double bonds, while 2,3-dimethyl-1,3-butadiene absorbed only 1 atom of oxygen per molecule.

The compounds in the second rank of instability, those oxidized through the diolefinic or cyclo-olefinic peroxides, may well include substances like 1,2-dimethyl-cyclohexane and -cyclopentane, which have been shown by Chavanne [10, 1929, 1932] to be attacked slowly by gaseous oxygen. The autoxidation of cyclohexene to give liquid and resinous peroxides and peroxides of polymers, as brought out by Stephens [60, 1928, 1931] and by Zelinskii and Borissov [70, 1930] points to cyclohexene as oxidizable to resins, even if too stable to act as an initiator of oxidation at low temperatures.

All the above work leads more or less to the same conclusions. The suggestions of Wagner and Hyman [66, 1930] that per-acids rather than peroxides are the chief intermediate in gum formation would seem to be doubtful because of an experiment by Yule and Wilson [69, 1931]. They subjected two portions of a freshly cracked gasoline to storage and gum test in presence of an addition of gummy gasoline, one part of which had been washed with sodium carbonate solution and the other not so washed. No diminution of gum formation was caused by the alkali washing, as might have been expected if per-acids were the active agents. In this case, peroxides and not per-acids would be responsible for the gum.

Another minor difference lies in the statement by Morrell, Dryer, Lowry, and Egluff that residual gum on evaporation is low in acids, whereas Story, Provine, and Bennett concluded that gum, both precipitated and residual, is mostly acids. The explanation presumably lies in the fact that the latter authors determined acids by alcoholic saponification, and the former by titration in water. The more drastic treatment would locate acids not recognized by the milder process, and the conclusion of Story, Provine, and Bennett is presumably correct.

Theory of Gum Formation.

In the present confused state of the literature on hydrocarbon peroxides it does not seem wise to formulate specific reactions for the production of such compounds from gasoline. Their structure is not known, and even their existence has not been definitely proved. Such peroxides as have been isolated vary considerably in properties, and there is some possibility that the freshly formed peroxides active in the gum reaction may differ considerably from the compounds which have been or can be isolated. The physical chemistry of the subject is even less definite. As a working hypothesis we may assume that molecular oxygen reacts with conjugated diolefines, rapidly when they are activated by sunlight or heat, more slowly in the dark or ordinary temperature, to form compounds which respond to empirical tests for peroxides; they are apparently active oxidizing agents and catalysts for oxidation. In the absence of further activating energy these substances are reduced or converted, with oxidation of other, more stable constituents of the gasoline. If activating energy is supplied, the peroxide content is maintained, and oxidation of the other hydrocarbons continues actively through the peroxides. Presumably the compounds of different stability levels are attacked in turn—cyclic olefines, simple olefines, &c. The reaction may be an autocatalytic one; larger quantities of more active catalysts

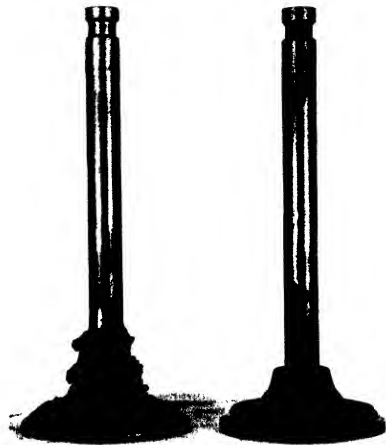

FIG. 1. Intake and exhaust valves from small experimental engine operated on poorly refined vapour-phase cracked gasoline of copper dish gum number about 900

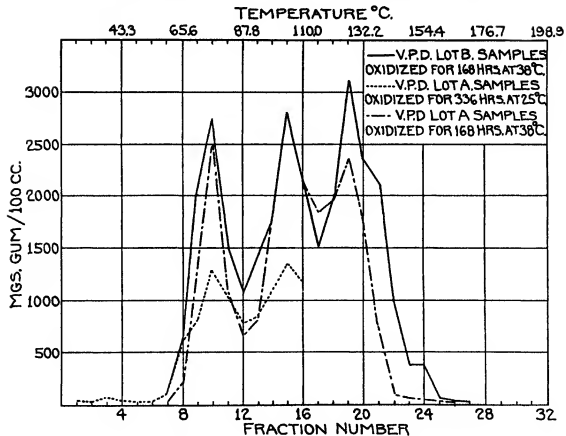

FIG. 2. Distribution as to boiling-point of the chief gum-forming constituents of a vapour-phase cracked gasoline

may be required as the attack ascends the levels of stability. Whether or not this is true, it is probable that at least part of the peroxide content disappears by direct reaction with unsaturated hydrocarbons.

The Prileschaeff reaction [48, 1912] involving production of alkylene oxides from olefines and peroxides, by direct transfer of active oxygen, is well known; the alkylene oxides in certain cases are hydrolysed to glycols, which can be dehydrated, with rearrangement to ketones. In some cases the alkylene oxides are so unstable that they decompose directly to aldehydes containing one less carbon than the original compound. It should be remembered that much of Prileschaeff's work was on hydrocarbon derivatives, alcohols, &c., rather than on hydrocarbons. Such compounds are undoubtedly produced during gasoline oxidation. Whatever mechanism be assumed, the production of aldehydes and ketones from peroxides of olefinic hydrocarbons is well known, and the conversion of these compounds to high molecular weight acids is readily understood. The fact noted by Story, Province, and Bennett that the lower molecular weight acids recovered are unsaturated suggests again the importance of diolefines in the general mechanism of oxidation. Where the supply of oxygen is not limited and the activating energy is supplied, oxidation advances so far that oxidation products separate out as an immiscible phase, made up of rather volatile aldehydes and ketones, low molecular weight acids, higher acids, unstable peroxides, and probably a little water. When this is heated, evaporation of volatile compounds occurs, together with decomposition and condensation of the unstable, non-volatile substances. The end product is a non-volatile resin, made up mostly of high molecular weight acids, perhaps resembling abietic acid. Where the concentration of oxidation products is not high no phase separates out, but essentially the same kind of non-volatile resin is recovered when the gasoline is evaporated.

Gum Formation in Motor Benzols.

The formation of gum in motor benzols was referred to in the early part of this discussion. The joint reports of the National Benzole Association and the University of Leeds have described the research work of Hoffert and Claxton, which established for coal-tar benzol fuels essentially the same mechanism for gum formation as has subsequently been shown for petroleum gasoline. Crude benzol mixtures are, theoretically at least, simpler in composition than cracked gasoline, and the oxidation with subsequent gumming can be attributed with greater probability to such compounds as cyclopentadiene or its dimer, styrene, and indene and coumarone, where the boiling-point of the benzol goes high enough to include such compounds. The presence and reactions of these compounds are known. Apparently conjugated and cyclic diolefines, such as cause trouble in gasoline, are not excluded by any existing experimental work. The likelihood is, however, that the thermal history of the coal-tar light oil is such that these highly unstable substances do not survive.

The Formation of Gum in Gas-distributing Systems.

The formation of gum in the systems distributing manufactured gas has been recognized within the past 10 years as a cause of much trouble. It was encountered with carburetted water gas somewhat earlier, and its causes and remedies are discussed in the publications of R. L. Brown [8, 1923, 1925]. The gum is attributed to the oxidation and

polymerization of indene and styrene and similar compounds produced in the cracking of the gas oil employed for the carburetting operation. Brown showed that where cracking of the gas oil was insufficient or incomplete, the proportion of these compounds rose to troublesome proportions. Since a cracking insufficient for water-gas carburetting is much too drastic for making gasoline, it may be seen that the two problems differ basically. Gum of the type just discussed is known to the gas industry as liquid-phase gum. The material known as vapour-phase gum is encountered in coal gas and coke-oven gas. It is usually dry and powdery, and is strongly acidic, whereas liquid-phase gum is nearly neutral. It has been studied by Wenzel [68, 1933] and by Fulweiler [26, 1932; 67, 1933-4]. It is attributed to the oxidation of unsaturated compounds by oxides of nitrogen in the gas; these latter, presumably, originate in reactions of the air in the iron-oxide purifying installations.

Testing for Gum Content

The testing of gasolines for gum content has undergone rapid development during recent years. The earliest test, and for many years the only one used, was the copper-dish evaporation test. This was developed, according to E. W. Dean [15, 1919], in the laboratory of the Atlantic Refining Co. for the examination of aviation gasoline. In 1920 Dean [16] described it as an unsatisfactory test because of the difficulty in reproducing results and the large influence of variation in details of manipulation. It was at that time employed as an indication of content of corrosive sulphur compounds.

The test as described in Technical Paper 323-B, Bureau of Mines, in 1927 involves evaporating 100 c.c. of gasoline in a hemispherical copper dish approximately 3½ in. in diameter, freshly polished, on an actively boiling steam bath. Steam must come in contact with the outer surface of the dish up to the line of the gasoline. The dish is left on the bath until all volatile material has disappeared. In many laboratories a step involving drying the dish in an air oven for 30 min. at 110° C. has been added, in an effort to eliminate the variable caused by incomplete evaporation and to remove water. Elementary sulphur or corrosive sulphur compounds colour the dish grey or black, and any weighable residue, expressed in milligrams per 100 c.c. of gasoline, is considered to be gum. Obviously any other non-volatile material dissolved in the gasoline, such as lubricating oil, will appear as gum in this test. It is unsatisfactory in several ways. The rate of evaporation affects the results considerably, since the longer any part of the gasoline remains in the dish, the more opportunity it has for oxidation. Even if the rate of heating and the control of air currents over the dish are reproduced, variations in the volatility of the gasoline will affect the results. Thus a highly cracked and very unstable gasoline, if it is very volatile, can give a lower gum figure than a better refined gasoline which evaporates more slowly. It will be seen that the test serves a double purpose, first, of determining any non-volatile gum present at the time of test, and second, of oxidizing at least part of the unstable hydrocarbons to gum during the test, by air oxidation catalysed by the copper surface. Since the two effects cannot be distinguished, the procedure serves as a qualifying test, but not as a rating test. A gasoline passing it is likely to be of good quality, but, except for wide variations, one cannot say how bad a gasoline is which does not pass the test.

Some figures as to the magnitude of the results are of

interest. In 1920 Dean set 30 mg. per 100 c.c. as a dividing line between gasolines of low gum content and those of high gum content. Over a period of 10 years American motor gasolines not containing lubricating oil have averaged from 10 to 35 mg. per 100 c.c.; aviation gasolines have been unofficially held to 3 mg. per 100 c.c. by many producers and purchasers; unrefined cracked gasolines will show from 300 mg. to as much as 1,000 mg. per 100 c.c. for the high-temperature vapour-phase type of cracking.

In 1922 Smith and Cooke [57], recognizing the faults of the copper-dish method, used glass dishes on a water bath, and in 1925 Cooke [13], introduced the steam-oven test in which the gasoline sample is evaporated in a porcelain dish placed in an oven through which steam is passing. This test, though never well standardized, has been widely used. A procedure devised by D. R. Stevens and employed in the author's laboratory involved the use of a 50-c.c. sample of gasoline in a 3½-in. porcelain evaporating dish. This was set in an insulated copper oven through which steam heated to 240° F. was passed at a rate just sufficient to show at the outlet of the oven. The evaporation period was 16 hr.; at the end of this time the dish was dried for 30 min. at 105° C. before weighing. This procedure gave reproducible results. The test serves to determine non-volatile gum in the gasoline at the time of test, and the results are much lower in magnitude than the copper-dish figures. Up to 10 or 12 mg. per 100 c.c. is perhaps a fair average for commercial gasolines, and 25 mg. per 100 c.c. is a fairly high figure.

The first definite tests proposed for separate determination of preformed or existing gum, and of potential gum to be expected after a long period of storage, were those of Voorhees and Eisinger [65, 1929]. The preformed gum was measured by a modification of the Cooke steam-oven test; 50-c.c. samples were evaporated in 200-c.c. Pyrex glass dishes in a current of steam at a temperature of 320–50° F. for 10 hrs. The residue represents the gum present at the time of test. For estimating potential gum 20-c.c. samples were heated in a steam bath in 500-c.c. flasks filled with oxygen, for 5 hrs. At the end of this time the sample was evaporated in a porcelain or glass dish in a steam oven. The rubber stoppers employed to close the flasks caused trouble, since the gasoline vapour attacked them, and particles of rubber dropped off, increasing the gum values irregularly. In the author's laboratory gingerale bottles closed with cork-gasketed bottle-caps served to avoid this difficulty. By this test stable gasolines showed values up to 50 mg. per 100 c.c., and highly cracked unrefined stocks yielded several thousand mg. per 100 c.c. Voorhees and Eisinger's oxygen absorption test, mentioned above, was described at this time, but was not employed for testing.

Testing for potential gum and for stability in storage was advanced substantially soon after this by Hunn, Fischer, and Blackwood [31, 1930] who described the oxygen-stability test in essentially its present form. A sample of 100 c.c. of the gasoline was heated to steam-bath temperature, under a pressure of oxygen 100 lb. when cold, in a glass bottle contained in a small steel bomb connected to a recording pressure gauge. The pressure rose on heating to about 130 lb. and stayed approximately constant during the induction period for the oxidation, after which it began to drop as oxygen was absorbed. For a gasoline stable enough for long storage (presumably 6 months to a year) they found an induction period of about 3½ hrs. Careful examination of the pressure curves shows that the pressure

rises very slightly before the 'break'. This is presumably due to the formation of volatile oxidation products in small amount and without corresponding absorption of oxygen. This phenomenon is shown in Fig. 4, on p. 1025.

For determining gum existing at the time of test they proposed an air-jet evaporation method, in which 100 c.c. of the gasoline in question, in a porcelain dish on a boiling-water bath, was evaporated by a standardized air stream playing on the centre of the gasoline surface. Evaporation required about 15 min. and subsequent drying at 105° C. to constant weight, 2 to 3 hrs. The results agreed closely with the Cooke steam-oven test. A similar test was described later by Littlejohn, Thomas, and Thompson [37, 1930]; by suitable dilution, the total amount of gum deposited was kept below 11 mg. and the drying was at 150° C.

An alternative stability test, involving the measurement of the volume of oxygen absorbed by a sample of gasoline shaken at steam-bath temperature and atmospheric pressure, was proposed by Voorhees, and is described by Rogers, Bussies, and Ward [53, 1933].

The oxygen-stability test and its validity for predicting the ageing properties of gasoline have been discussed and criticized by Aldrich and Robie [1, 1932], by Ramsay [49, 1932], and by Ramsay and Davis [50, 1933]. The former point out that the induction period varies inversely with the pressure, and directly with the temperature in such a way that tests at two temperatures are necessary before the time-stability curve can be extrapolated to predict stability in storage; Ramsay reached essentially the same conclusion. Ramsay and Davis criticized the apparatus, and showed that a true induction period could be determined if a correction for lag in heating was applied. As an alternative they proposed that the apparatus be standardized rigidly.

It would seem that the value of such refinements in the test is doubtful unless a standardized condition of storage can be set up. It is obvious that the rate of oxidation will vary with ratio of surface to volume, with the temperature, the material, and cleanliness of the storage tank and with other similar conditions.

For the determination of existing gum the condition is only slightly different. The determination can be made precisely reproducible, but since the ultimate significance of the test in its relation to engine deposits from the gasoline is uncertain, and since, further, engines and their service conditions vary widely, there is some question here also about the importance of high precision. Recent developments in this test have taken the direction of a standardization of the air-jet method. It was compared with the steam-bath evaporation method by Bridgeman and Aldrich [3, 1931] and the influence of temperature of evaporation was investigated by Bridgeman and Molitor [4, 1933]. From these studies it is concluded that volume evaporated and temperature of evaporation do not change the relative results as to gum content for a series of gasolines. In 1932 the American Society for Testing Materials had two modifications of the test under consideration. In the first, evaporation was on a steam bath, and in the second, on an ethylene-glycol bath at 180–90° C., flow rate and other details being essentially the same. Because of the economy in time realized, the latter has been preferred. It was first described by Mulligan, Lovell, and Boyd [47, 1932]. It is now a tentative standard method of the A.S.T.M. Serial Designation D 381–34 T. A 50-c.c. sample of the gasoline is evaporated from a 100-c.c.

beaker in an air stream of 1 litre per min. The air is heated to 305–20° F. (151.7–160° C.) by passing through a coil in a bath of ethylene glycol and the beaker is set in the same bath. The results are expressed in mg. per 100 c.c. Evaporation at this high temperature gives results appreciably lower than either the air-jet evaporation method at 100° C. or the steam-oven method of Cooke. Since all results are relative the difference is not significant.

Opinion is well crystallized as to the need for two tests, one determining dissolved gum actually present at the time of treating, and the other measuring the probable life of the gasoline in storage. The first is important for the use of the gasoline in engines and the other for the keeping of the product. Since engines vary and storage conditions vary, it does not seem that great precision in the tests or exact correlation between testing and service are required. Whatever is done will throw valuable light on the situation, but there will presumably exist a margin of uncertainty about the safe limits of both the amount of gum likely to cause trouble in any particular engine and the amount of oxidation likely to occur in any particular storage place.

Minor variations on the above tests and additional tests have been employed to some extent. The so-called oxygen-stability gum, for instance, is the amount of gum determined by evaporation in steam after the sample of gasoline has been oxidized for 4 hrs. in the oxygen-stability apparatus, irrespective of the induction period. It is useful chiefly for comparison purposes. Exposure of samples under definite conditions to 10 hrs. and to 20 hrs. of sunlight has been practised, and in the author's laboratory standardized exposure for 4 hrs. to light from a 110-volt quartz-mercury arc lamp has been found useful. In all these cases gum content is determined by evaporation in a steam oven after exposure, and, if desired, the induction period can be measured.

Gum Tolerance of Gasoline Engines

The amount of gum which can be tolerated in a gasoline engine without trouble from deposits is a matter of much uncertainty. There is some popular misunderstanding as to what causes valve trouble in engines. Valves stuck in their guides are not uncommon, but they are almost without exception exhaust valves; this difficulty is to be attributed to lubricating oil depositing on the valve guide and being decomposed by the hot exhaust gas to form a solid which builds up and binds the stem. It is difficult to imagine any appreciable amount of gum persisting through the flame area and dropping out on the exhaust-valve stem. As a matter of fact, it is general experience in experimental work on gum-bearing gasolines to find the deposits on the intake-valve stems and guides and in the intake system, and not on the exhaust valve. Clogged intake-valve systems are almost unknown in automotive practice at present, and this serves to indicate that the gasoline sold is sufficiently low in gum content to be well on the safe side. That gum trouble can be very real with gasolines of high gum content is indicated by photographs of engine parts published by Voorhees and Eisinger and by Hunn, Fischer, and Blackwood (loc. cit.). Fig. 1 shows the intake and exhaust valves of an experimental engine operated in the author's laboratory for 5 hrs. on a poorly refined vapour-phase cracked gasoline having a gum content, by copper-dish evaporation, of about 900. The engine stalled at this point. It will be noted that the exhaust valve is relatively clean.

The engine experiments of Voorhees and Eisinger involved laboratory tests with a small single-cylinder air-cooled unit (Delco) sold for power generation on farms. There was some variation in the speed, load, and length of test, so that conditions were not exactly reproducible; a 5-gal. lot of each fuel was consumed for a test. The significance of the copper-dish, oxygen-gum, and steam-oven gum tests were considered; the results pointed to the fact that the potential gum by oxidation and the copper-dish gum were not significant, but that the steam-oven value gave some indication of deposits to be anticipated. Two cars run on the road gave similar results. The data obtained suggested that gasoline containing more than 10 mg. per 100 c.c. of gum by the Cooke steam-oven test might produce a noticeable deposit under severe conditions. Water-cooled Delco engines were used by Hunn, Fischer, and Blackwood, the engine temperatures thus not going as high as with the air-cooled units. The conclusion as to significance of tests is of the same nature as that from the studies of Voorhees and Eisinger. The copper-dish test was found to be of no value in predicting deposits. The air-jet test at steam-bath temperatures was preferred over the Cooke steam-oven test. From 10 to 20% of the gum present by the air-jet test was recovered from the engines as deposited material. By a road test on a single automobile equipped with an overhead valve engine operated during three 5,000-mile periods it was noted that a gasoline containing 10 mg. per 100 c.c. of dissolved gum gave no trouble. One of 25 mg. gave noticeable loss of power after 3,000 miles, and a fuel of 50 mg. gum content showed loss of power and some valve sticking.

The idea that intake manifold temperature influenced the amount of deposit from a gum-bearing gasoline was suggested by one experiment of Voorhees and Eisinger. This was brought out independently and somewhat later by Marley and Gruse [39, 1932]. A single-cylinder water-cooled Delco and two full-sized single-cylinder water-cooled experimental engines, one L-head and the other valve-in-head, were employed; the fuels were gasolines ranging up to 35 mg. per 100 c.c. of preformed gum by the steam-oven test. Intake mixture temperatures were regulated over the range encountered in automobile practice, up to 90° C. (194° F.). Gum-depositing tendency was measured by scraping and weighing the deposits from intake manifold, intake valve, and valve chamber. It was found at low intake temperatures (40° C. = 104° F.) the gum content made very little difference, no appreciable deposits being obtained with gasolines varying from 3 to 35 mg. preformed gum. As temperature rose, the deposits increased with the temperature except for the 3-mg. fuel, which left a clean engine under all conditions. The air-fuel mixture ratio made no difference at low temperatures, but at high temperatures the richer mixtures left more gum. By observing carbon deposits (the deposit in the combustion chamber) it was found that at high temperatures, when gum dropped out in the intake system, the carbon deposit did not change with gum content of the fuel. At low intake temperatures some of the gum was carried on into the engine and increased the combustion-chamber deposit in proportion to its amount in the gasoline. This is illustrated in Fig. 3. No attempt was made in this work to set gum tolerances for commercial gasolines, but it was pointed out that the conditions were more severe than for road practice, and that trouble would not be encountered in automotive engines so soon as it occurred in these experiments. The present uncertainty about gum tolerance

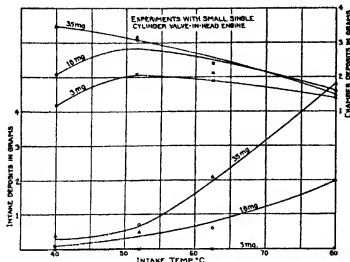

FIG. 3. Influence of gum content of gasoline and of intake temperature on amount and distribution of deposits in the engine.

is well presented in a good summary of the situation by Egloff, Morrell, Wirth, and Murphy [21, 1930]. They suggest that 10 mg. per 100 c.c. by the air-jet test and 25 mg. per 100 c.c. by the copper-dish test will characterize satisfactory fuels, but there is no present basis for saying how much more gum could be carried before trouble would be encountered.

Use of Oxidation Inhibitors

Introduction.

References to the action of specific compounds in slowing down or preventing the oxidation by air of oxidizable substances are scattered through the chemical literature for the past hundred years. An intelligent recognition of the existence of inhibitors of oxidation is more a matter of the past 20 years. In the rubber industry it was recognized about 1912 that certain accelerators of vulcanization added age-resistance to the rubber in which they were incorporated. Identification of age-resistors as independent of accelerators occurred about 1917 [14, 1934]. The publications of Moureu and Dufraisse [46] on anti-oxidants began in 1922, although their work started much earlier. In 1926 Smith and Wilson [58] published a study of the effect of inhibiting agents on the absorption of oxygen by unsaturated substances such as fats, fatty oils, rubber, &c. The application of these ideas to hydrocarbon motor fuels apparently occurred first in England and with motor benzols. These products when used without refining caused recognizable motor trouble because of resin deposits, and treating with sulphuric acid to avoid this caused much higher losses than in the case of the cracked gasolines made at that time—8 or 9% as against 2 or 3%. The influence of phenols in preventing the formation of resin in motor benzol was reported by the Benzole Research Committee in its Fourth Report [32, 1927]. Tricresol was observed to be effective in concentration as low as 0.04%. The use of ortho- and para-cresol is discussed by Hoffert and Claxton [30, 1933].

Anti-oxidants for Gasoline.

The first published account of the use of oxidation inhibitors for cracked gasoline is that by Egloff, Faragher, and Morrell [20, 1929]. They recognized that loss of anti-knock value, darkening of colour, and development of gum were all caused by oxidation, and found that these

effects could be delayed or prevented by adding anti-oxidants. Aniline, hydroquinone, naphthalene, and anthracene in the amount of 0.1% were found to prevent deterioration of anti-knock value during an accelerated oxidation test (5 hrs. at 212° F. in an atmosphere of oxygen), and the same substances, with the addition of dimethyl aniline and urea, were effective for delaying gum formation, either by the oxidation test or by exposure to sunlight for 24 hrs. The effects at these concentrations were very definite, copper-dish gum being reduced in some cases from 330 to as low as 10. The results for preservation of light colour, while equally definite, were less regular, in the sense that an inhibitor was sometimes effective for one gasoline, but not for another. Aniline was not active for this purpose, and a number of compounds, not effective in gum prevention, proved to have value for colour preservation. This test involved exposure to sunlight for 24 hrs.

This exploratory work was followed by more detailed studies from the same laboratory [22, 1932-3]. Instead of 0.1% of added substance, 0.01% was used; instead of an accelerated oxygen test involving heating for 5 hrs. in a glass bottle in a steam bath, the high-pressure oxygen test of Hunn, Fischer, and Blackwood, 4 hrs. in a steel bomb, was employed. A wide range of substances was tested and accelerated tests were checked against storage in glass bottles with access of air. A single example will show the degree of effectiveness of the compounds studied:

	Gum				Induction period, min.
	Colour, Saybolt	Copper dish	Air Jet	Octane no.	
Gasoline at beginning	19	85	4	77	15
After 6 months' storage + Alpha-naphthol, 0.01% at beginning	13	14	6	77	over 240
After 6 months	19	12	2	74	..

Nearly 200 compounds were tested. Substances showing pronounced inhibiting properties belonged in general to the classes of phenols and aromatic amines. However, the simple phenols and amines were found to be rather low in inhibiting value. Really effective compounds fell chiefly into the classes of substances containing one of the following structures:

- More than one hydroxyl or amine group;
- Aromatic hydroxyl+aromatic amine;
- Aromatic hydroxyl or amine and alkyl groups;
- Aromatic hydroxyl or amine and other modifying groups;
- Aromatic secondary amine.

The most effective phenols were catechol, pyrogallol, and alpha-naphthol; para-aminophenol fell in the same class. The best amines were para-phenylene diamine and para-diaminodiphenyl amine, but they were at best much less active than the phenols just listed. Thio-diphenyl amine was better than the simple amines, but less active than the phenols. The authors followed this study by a correlation of inhibiting value with critical oxidation potential, the latter being defined according to Fieser [24, 1930] as the potential at which the rate of oxidation of the reducing agent in an electrometric oxidation-reduction system becomes so small as to be just detectable. Where both values can be determined it has been found to be about 0.136 volt below the normal oxidation-reduction potential for the oxidation of one hydrogen atom and 0.068 volt below the normal value for oxidation of two hydrogen atoms in one compound. The figures for

critical oxidation potential used in the correlation were those determined by Fieser, except for a small number calculated according to rules devised by him. Inhibiting values in the oxygen-pressure apparatus produced by 0.0005 mol of the chemical in 100 g. of gasoline were compared with the oxidation values, and it was found that in general substances of little or no inhibiting value

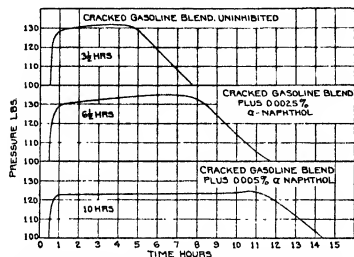

Fig. 4. Time-pressure curves on an oxygen stability apparatus for a cracked gasoline uninhibited, and inhibited with small proportions of α -naphthol.

possessed critical oxidation potentials of 1.064 volts and above; inhibitors of intermediate value fell in the class from 0.799 to 1.043 volts and the powerful inhibitors showed values between 0.609 and 0.797 volt. A considerable number of exceptions were encountered, but some of these could be explained on the basis of side reactions to which the compounds were liable. Later work showed an approximate relation between the critical oxidation potentials of the inhibitors employed and the stability in storage of the gasolines protected [19, 1935].

The value of substituted amino phenols, specifically, monobenzyl para-amino-phenol, and dibenzyl para-amino-phenol was brought out by Rogers and Voorhees [55, 1933]. For certain gasolines the monobenzyl compound is (in the same concentration) appreciably more effective in raising the induction period than are hydroquinone, catechol, and alpha-naphthol, and slightly more effective than pyrogallol. This is shown by data of Rogers and Voorhees.

Anti-oxidant	Induction period for 0.002% concentration (min.)
Hydroquinone	140
Catechol	150
Alpha-naphthol	190
Pyrogallol	310
Para-benzyl amino-phenol	345

The induction period is that determined by the shaking test of Voorhees [64, 1933] and not the pressure oxidation test of Hunn, Fischer, and Blackwood [31, 1930].

It is generally understood that the functioning of an inhibitor involves only the delaying of the oxidation. Once the induction period has been passed, the oxidation sets in and is assumed to follow the course which it would have taken earlier had the inhibitors not been present. Whether this is precisely true is not certain; the gum formation may

go at a different rate or to some extent in a different direction; but it is true practically. It may safely be assumed that once the period of protection is over, gum formation will proceed approximately as it does in the unprotected gasoline. The relatively close correspondence of pressure curves of a gasoline with and without an anti-oxidant (in this case alpha-naphthol) is shown in Fig. 4.

The prevention of darkening of colour of gasolines by addition of inhibitors is closely related to the prevention of oxidation. The preferred materials for this purpose are tributyl and triamyl amines, added in amounts of the order of 0.002%. The matter is discussed by Sorg [59, 1935]. An interesting modification of the use of anti-oxidants for gasolines involves the use of inhibitors which are dyes, and which will fade or change colour as they are depleted. Another variation involves the use of a dye which will change colour when oxidized, the oxidation being prevented by the inhibitor introduced to protect the gasoline. Such systems are described by Lowry, Egloff, Morrell, and Dryer [36, 1935].

Anti-oxidants for Lubricating Oils.

The inhibitors so far discussed have been considered in connexion with gasoline only. The application of anti-oxidants to lubricating oils has lagged considerably behind their use for motor fuels, because of a less urgent need. While oxidation is no doubt an important factor in the deterioration of lubricating oils, the latter are exposed to other adverse influences, catalytic, thermal, and mechanical, which make it difficult to determine just how important oxidation alone may be. There is a large literature on the oxidation of turbine lubricating oils and insulating oils. More recently attention has been given to the influence of oxidation in the deterioration of gasoline engine oils [17, 1933; 54, 1934]. The oxidation of pharmaceutical white oil was studied under various conditions by Haslam and Frolich [28, 1927] and by Mead [41, 1927]; the inhibiting influence of nitrobenzene, nitrotoluene, and sulphur was noted. The oxidation of lubricating oils may show itself in various ways depending on the oil itself, the nature of the oxidizing conditions, the extent of the oxidation, and the interest of the investigator. A medicinal oil may be ruined by the development of slight taste or odour; a turbine oil will tolerate only a small amount of acidic oxidation products, and a Diesel engine lubricating oil is still acceptable with a slight content of both acidic products and of insoluble sludge. There is no agreement as to the form of oxidation tests to be applied to lubricating oils nor as to the significance of any test in its relation to expected service.

In view of such uncertainty it can be said that the use of anti-oxidants in lubricating oils is essentially undeveloped. It is reported that steam-turbine oils containing 0.1% of beta-naphthol have been sold, and there are a few scattered references in the patent literature to the use of other anti-oxidants, phenyl-alpha-naphthylamine [12, 1929], maleic acid [11, 1904], diphenylamine, gallic acid, and dibutyl resorcinol [52, 1932], and lead tetraethyl [38, 1932]. The general subject is so complicated that any development that is likely to occur soon will probably follow the line of empirical effort to suppress some particular manifestation of oxidation, such as acidity in turbine oils, sludge deposition in insulating oils, or both sludge and acidity in gasoline engine oils.

Mechanism of Anti-oxidant Protection.

The mechanism by which anti-oxidants function is a matter of practical as well as theoretical interest; it has been the subject of much discussion. A chain reaction may be postulated, and this has been done by Backström [2, 1927]; and with the addition of a discussion of electric changes, by Milas [42, 1929]. The explanation of Moureu and Dufraisse [45, 1926] is perhaps more simple, and adequate for the present purpose. It is apparently generally true that an inhibitor of oxidation is itself easily oxidized; at the same time there are present in the unstable substance (gasoline in this case) molecules similarly sensitive. It is assumed that these hydrocarbon molecules form peroxides with the molecular oxygen present, this change occurring with an absorption of energy and thus between activated rather than average molecules. The hydrocarbon peroxides may oxidize the molecules of anti-oxidant or the anti-oxidant may be oxidized directly by the oxygen present, yielding in either case a peroxide of the anti-oxidant. This may be represented:

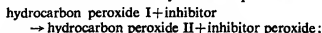
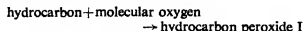

the two peroxides react to destroy each other and release molecular oxygen

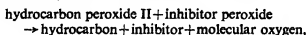

and this leaves the system in its original state. The alternative mentioned above, that the inhibitor peroxide might be formed directly from the inhibitor and molecular oxygen, does not change the final reaction or the final state.

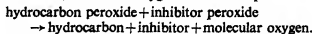
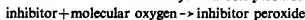
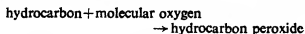

As above, the system returns to its original state. If it is assumed that the oxidation to gum must proceed through the peroxides, then the inhibitor blocks the path and one molecule can decompose many activated peroxide molecules just as one soldier in a defile can disarm a number of enemies who can come at him only one at a time. Ultimately the single defender is removed, and that is what finally happens to the inhibitor. The protection is not indefinite, and is measured by what has been termed the induction period. Presumably the anti-oxidant, which must be a highly reactive substance, readily undergoes side reactions leading to other products. Thus the inhibitor peroxide may be reduced directly by hydrocarbon molecules in such a way as not to regenerate the original inhibitor. In any case the anti-oxidant is gradually removed or destroyed and the oxidation proceeds more or less normally.

The Present Situation.

The anti-oxidants used commercially for gasoline at present are believed to be chiefly alpha-naphthol, monobenzyl para-amino-phenol, and a material which is probably a selected fraction of wood tar [35, 1932] containing, presumably, a mixture of creosole, catechol, ethyl guaiacol, mono-ethers of pyrogallol, and some xylenols. Pyrogallol and catechol have been considered to some extent. The selection of these and similar compounds depends on a variety of conditions. The effectiveness changes with the gasoline stock to be protected and with the conditions of storage; the solubility of the substance in water (always present in gasoline storage) and its partition coefficient between any particular gasoline and water will be important; and finally, the price per arbitrary unit of effective protection must be evaluated.

There are several ways of calculating the comparative anti-oxidant protection afforded by several given substances. A gum-inhibiting index has been proposed by Scheumann [56, 1933]; it is the average per cent. potential gum reduction divided by the average concentration of inhibitor in mg. per 100 c.c. The matter can also be approached by measuring the relative concentrations of various compounds required to give a definite induction period. Because of the variation in the response of the same gasoline to different inhibitors and of different gasolines to the same inhibitor, and further because of the difficulty in continuing to produce over a time period a cracked gasoline which is in every way uniform, cyclohexene has been proposed as a reproducible chemical reference hydrocarbon for evaluating anti-oxidants [18, 1935].

The use of oxidation inhibitors for gasoline has proved useful; for lubricating oils it can hardly be said to have begun. Much interest has been aroused in the subject, however, and when the oxidation of lubricating oils in various types of service is better understood, there is small doubt that useful application of this method of hindering deterioration will be possible.

The history of the gum problem is one of considerable interest. The development of gum in gasoline was a few years ago an important obstacle to any large extension of the use of cracking in supplying the increasing demand for motor fuel. It was at the same time the chief obstacle to any large increase in the temperature of cracking, aimed at the production of better anti-knock gasolines. Gum development practically never came to the attention of the gasoline-consuming public as a source of trouble in automobiles; at present, because of the introduction of anti-oxidants, it offers no threats. Future development may involve the production of more stable cracked gasoline, more permanent anti-oxidants, and more precise determination of the amount of gum which may be tolerated in the most susceptible motors; no matter what these may lead to, it is probable that the principle of inhibiting oxidation of motor fuel by anti-oxidant chemicals is well established.

REFERENCES

- ALDRICH, E. W., and ROBBE, N. P. *J.S.A.E.* **30**, 198 t (1932).
- BACKSTRÖM, H. L. J. *Trans. Faraday Soc.* **24**, 601 (1928); *J.A.C.S.* **49**, 1460 (1927).
- BRIDGEMAN, O. C., and ALDRICH, E. W. *J.S.A.E.* **28**, 191 (1931).
- BRIDGEMAN, O. C., and MOLLITOR, J. C. *J.S.A.E.* **33**, 283 t (1933).
- BROOKS, B. T. *The Chemistry of the Non-Benzenoid Hydrocarbons and Their Simple Derivatives*, 427 (1922).
- *Ind. Eng. Chem.* **18**, 1198 (1926).
- BROOKS, B. T., and HUMPHREY, I. *J.A.C.S.* **40**, 852 (1918).
- BROWN, R. L. *Ind. Eng. Chem.* **15**, 1147 (1923); **17**, 168 (1925); *Bur. Mines Repts. Investigations*, no. 2503 (July 1923).
- CASSAR, H. A. *Ind. Eng. Chem.* **23**, 1132 (1931).
- CHAVANNE, P. *A.P.I. Bull.* **10**, no. 55, 3 (1929); *Chim. Belg.* **41**, 209 (1932).
- CLARK, F. M. C. P. 338,840 (23 Jan. 1904).
- B.P. 351,171 (6 May 1929).
- COOKE, M. B. *Bur. Mines Repts. Investigations*, nos. 2394, 2686 (1925).
- CRAWFORD, R. A. *Ind. Eng. Chem.* **26**, 931 (1934).
- DEAN, E. W. *Bur. Mines Tech. Paper* 214 (1919).
- DEAN, E. W., and HILL, H. H. *Bur. Mines Bull.* 191 (1920).
- DIETRICH, M. A. A.S.T.M. Symposium on Motor Oils, New York (1933).
- DRYER, C. G., LOWRY, C. D., EGLOFF, G., and MORRELL, J. C. *Ind. Eng. Chem.* **27**, 315 (1935).
- DRYER, C. G., MORRELL, J. C., EGLOFF, G., and LOWRY, C. D. *Ind. Eng. Chem.* **27**, 15 (1935).
- EGLOFF, G., FARAGHER, W. F., and MORRELL, J. C. *Nat. Petr. News*, **21**, no. 49, 40 (1929).
- EGLOFF, G., MORRELL, J. C., WIRTH, C., and MURPHY, G. B. *Proc. World Petr. Cong.*, **2**, 85 (1933).
- EGLOFF, G., MORRELL, J. C., LOWRY, C. D., and DRYER, C. G. *Ind. Eng. Chem.* **24**, 1375 (1932); **25**, 315, 804 (1933).
- ENGLER, C., and WEISSBERG, J. *Ber.* **33**, 1094 (1900).
- FIESER, L. F. *J.A.C.S.* **52**, 5204 (1930).
- FLOOD, D. T., HLADKEY, J. W., and EDGAR, G. *Ind. Eng. Chem.* **25**, 1234 (1933).
- FULWEILER, W. H. *Amer. Gas Assoc. Proc.* **14**, 838 (1932); *Gas Age Record*, **70**, 453 (1932).
- HALL, W. A. *J.I.P.T.* **1**, 102 (1914-15).
- HABLAM, R. T., and FROELICH, P. K. *Ind. Eng. Chem.* **19**, 292 (1927).
- HILL, H. H., and DEAN, E. W. *Bur. Mines Bull.* 191 (1920).
- HOFFERT, W. H., and CLANTON, G. *J.S.C.I.* **52**, 25 t (1933).
- HUNN, E. B., FISCHER, H. G. M., and BLACKWOOD, A. J. *J.S.A.E.* **26**, 31 (1930).
- Joint Research Committee (National Benzole Association and the University of Leeds), London, 1924-30.
- KOGERMAN, P. N. *Trans. 2nd World Power Conference, Berlin*, **8**, 33 (1930).
- *Trans. 2nd World Power Conference, Berlin*, **8**, 35 (1930).
- LOWRY, C. D., JR., and DRYER, C. G. U.S.P. 1,889,835-6 (6 Dec. 1932).
- LOWRY, C. D., EGLOFF, G., MORRELL, J. C., and DRYER, C. G. *Ind. Eng. Chem.* **27**, 413 (1935).
- LITTLEJOHN, W., THOMAS, W. H., and THOMPSON, H. B. *J.I.P.T.* **16**, 684 (1930).
- MCCABE, W. L., and MEAD, B. U.S.P. 1,857,761 (10 May 1932).
- MARLEY, S. P., and GRUSE, W. A. *Ind. Eng. Chem.* **24**, 1298 (1932).
- MARTIN, S. M., JR., GRUSE, W. A., and LOWY, A. *Ind. Eng. Chem.* **25**, 381 (1933).
- MEAD, B. *Ind. Eng. Chem.* **19**, 1240 (1927).
- MILAS, N. A. *J. Phys. Chem.* **33**, 1204 (1929).
- MORRELL, J. C., BENEDICT, W. L., and EGLOFF, G. *Ind. Eng. Chem.* **28**, 448 (1936).
- MORRELL, J. C., DRYER, C. G., LOWRY, C. D., and EGLOFF, G. *Ind. Eng. Chem.* **26**, 497, 885 (1934); *Amer. Chem. Soc. Petr. Div.*, New York, April (1935), preprint; San Francisco, August (1935) preprint.
- MORRELL, J. C., DRYER, C. G., LOWRY, C. D., and EGLOFF, G. *Ind. Eng. Chem.* **28**, 465 (1936).
- MOUREU, C., and DUFRAISSE, C. *Chem. Rev.* **3**, 151 (1926).
- *Comp. rend.*, **174**, 258 (1922).
- MULLIGAN, M. J., LOVELL, W. G., and BOYD, T. A. *Ind. Eng. Chem., Anal. Ed.* **4**, 351 (1932).
- PRILESCHAEV, N. *J. Russ. Phys. Chem. Soc.* **63**, 609 (1911); **44**, 613 (1912).
- RAMSAY, J. W. *Ind. Eng. Chem.* **24**, 539 (1932).
- RAMSAY, J. W., and DAVIS, H. S. *Ind. Eng. Chem.* **25**, 934 (1933).
- RITTMAN, W. F. *Bur. Mines Bull.* 114 (1916).
- ROGERS, T. H. U.S.P. 1,774,845 (2 Sept. 1932).
- ROGERS, T. H., BUSSIES, J. L., and WARD, P. T. *Ind. Eng. Chem.* **25**, 397 (1933).
- ROGERS, T. H., and SHOEMAKER, B. H. *Ind. Eng. Chem., Anal. Ed.* **6**, 419 (1934).
- ROGERS, T. H., and VOORHEES, V. *Ind. Eng. Chem.* **25**, 520 (1933).
- SCHUEMANN, W. W. *Oil and Gas J.* **31**, no. 46, 22 (1933).
- SMITH, N. A. C., and COOKE, M. B. *Bur. Mines Repts. Investigations*, no. 2394 (1922).
- SMITH, O. M., and WILSON, R. E. *Ind. Eng. Chem.* **18**, 691 (1926).
- SORG, L. V. *Ind. Eng. Chem.* **27**, 156 (1935).
- STEPHENS, H. N. *J.A.C.S.* **50**, 568 (1928); *Ber.* **64** b, 637 (1931).
- STOBBE, H. *Ber.* **52**, 1436 (1919).
- STORY, L. G., PROVINE, R. W., and BENNETT, H. T. *Ind. Eng. Chem.* **21**, 1079 (1929).
- THIELE, F. C. *Ber.* **33**, 666 (1920).
- VOORHEES, V. (article by Rogers &c.) *Ind. Eng. Chem.* **25**, 397 (1933).
- VOORHEES, V., and EISINGER, J. O. *J.S.A.E.* **24** (1929).
- WAGNER, C. R., and HYMAN, J. A.P.I. *Proc. 10th Ann. Meeting*, **11**, sect. III, 118 (1930).
- WARD, A. L., JORDAN, C. W., and FULWEILER, W. H. *Ind. Eng. Chem.* **24**, 969, 1283 (1932); **25**, 1224 (1933); **26**, 947, 1028 (1934).
- WENZEL, R. N. *Gas Age Record*, **71**, 413 (1933).
- YULE, J. A. C., and WILSON, C. P., JR. *Ind. Eng. Chem.* **23**, 1254 (1931).
- ZELINSKII, N. D., and BORISSOV, P. P. *Ber.* **63** b, 2362 (1930).

INDUSTRIAL OXIDATION OF PETROLEUM HYDROCARBONS

By A. W. BURWELL, Ph.D., F.A.I.C.

Alox Corporation, New York

EVER since the true nature of petroleum has been recognized, attempts have been made to produce other than the known products—gases, fuels, illuminating oils, and lubricating oils, using either the whole crude or fractions thereof. Among the first attempts were those aimed at the production of fatty acids to replace those existing in and obtainable from vegetable and animal sources. In 1884 E. Schaal [17] in Germany made fatty acids from petroleum hydrocarbons, but not in commercial quantity. From this time until about 1922 nothing resembling commercial production of such bodies had been established. At that time, probably due to the high prices of fats then prevailing, a more intensive study was made, and patents began to appear making various claims for fats and waxes made from petroleum or other hydrocarbons.

The oxidation of petroleum may be grouped into three main classes:

1. Oxidation of gaseous hydrocarbons.
2. Oxidation of liquid hydrocarbons.
3. Oxidation of paraffin wax.

A considerable literature has been accumulated in all of these fields, and great discrimination must be used in determining that of practical importance from much which is extraneous. In this article only work which is of value practically will be considered. For a much more exhaustive discussion of the literature see *The Chemistry of Petroleum Derivatives* by Ellis [7, 1934].

Oxidation of Gaseous Hydrocarbons

Formaldehyde has been formed by the oxidation of natural gas, consisting mainly of methane, with air, steam being used as diluent, to prevent explosions or too greatly localized oxidation, and in the presence of a metallic catalyst [19, 1906]. A large number of metals and metallic oxides were satisfactory as catalytic agents.

Subsequently, hydrocarbons of both the methane and ethylene series were oxidized with air or oxygen at low temperatures, using metallic oxides as catalysts, to produce aldehydes and acids [16, 1908]. Much difficulty with the process is experienced, however, since explosion occurs directly the temperature of the catalyst reaches the point of incandescence. The resultant acids and aldehydes of the process usually contain one carbon atom less than the original hydrocarbon. So far, however, no commercial processes have been developed for the oxidation of gaseous hydrocarbons.

Oxidation of Liquid Hydrocarbons

The oxidation of liquid hydrocarbons may be carried out along four general lines:

- (a) Oxidation in the vapour phase.
- (b) Oxidation in the liquid phase during distillation.
- (c) Oxidation in the liquid phase at high temperatures and pressures.
- (d) Oxidation in the liquid phase at low temperatures and pressures.

Oxidation in the Vapour Phase.

This type of oxidation is very difficult to control, and the reaction is very sensitive to change in any one of the factors which govern it: pressure, temperature, time of contact, and proportion of constituents in the reaction zone.

When a mixture of hydrocarbon vapours and air is passed through a heated reaction zone containing catalysts, aldehydes and aldehyde acids are produced by J. H. James [5, 1929]. The temperature in the reaction zone varies between 230 and 500° C., depending upon the type of petroleum distillate undergoing oxidation, and upon the efficiency of the catalyst. Steam may be admitted in order to complete vaporization in the case of heavy distillates. Oxides of metals which are capable of exhibiting more than one valency state are used as catalysts, e.g. vanadium or molybdenum. In the process the oil and air are both led into a heating and mixing vessel. The heated mixture of hydrocarbon vapours and air is then passed through a screen of the catalyst, and from there to a condenser. The time of contact of the mixture with the catalyst is about $\frac{3}{10}$ sec. A plant for the oxidation of petroleum in the vapour stage is described by Bittler and James [2, 1928] and is operating commercially for the production of 'Aldehol', trade name for a mixture used as an alcohol denaturant.

Another method has been proposed for the oxidation of hydrocarbons in the vapour phase. The distillate is cracked, and the lighter products obtained are then oxidized [8, 1924, 1929]. By this method, not only are monobasic acids produced in addition to aldehydes and aldehyde acids, but also dibasic acids.

Oxidation in the Liquid Phase during Distillation.

No process has been devised up to the present time of commercial value. In one process the oil is heated in a still to a temperature slightly lower than its boiling-point, and air is introduced through a perforated pipe near the bottom of the still. After the commencement of the reaction the heat generated is sufficient to maintain the temperature and to cause distillation of the lighter portions [6, 1914]. The temperature is so regulated that hydrogen of the hydrocarbon combines with the oxygen introduced. Steam may be introduced with the air, reducing discoloration of the still residue to a great extent. A similar method has been patented by the Société Anonyme des Combustibles Industriels for the oxidation of hydrocarbons such as wood tar and schist oils [18, 1905].

Oxidation in the Liquid Phase at High Pressures and Temperatures.

A considerable amount of work has been done on the oxidation of petroleum at high temperatures and pressures, and results have been sufficiently encouraging to warrant further effort. In one method crude petroleum, or its distillates, is mixed with powdered coal, coke, or peat, and then heated and oxidized by passing air through the mass [14, 1925]. If, for example, gas oil be used, the oil is heated in a still to 260° C. at a pressure of 20 atm. Air is intro-

duced, and the temperature rises to 385–400° C., while the mass is distilling. The distillate obtained during oxidation separates upon standing into an upper, water-insoluble layer, an intermediate layer, and an aqueous solution of acids. Acids, phenols, and aldehydes are separated from the top layer, and the residue of the layer is washed, treated with sulphuric acid, and distilled to give a motor fuel. The bottom aqueous layer contains acids, aldehydes, alcohols, and ketones. On distillation it yields acetaldehyde and a liquid which may be used as a resin solvent or added to motor fuel to increase its anti-knock qualities. The residue is treated with sulphuric acid and steam distilled to yield gums.

Oxidation in the Liquid Phase at Low Pressures and Temperatures.

Most of the work done in the oxidation of high-boiling petroleum fractions has had the production of fatty acid as its goal. In order to obtain fats or acids of reasonably high molecular weight, simulating natural fats or their acids, it is necessary to use hydrocarbons of at least the lowest molecular weight from which the same molecular weight of fat could be produced. This carries the boiling-points of the hydrocarbons so high that in the vapour phase cracking or splitting of the hydrocarbon molecule would occur.

In the liquid phase, temperatures permitting of the slower oxidation of the hydrocarbon can be employed without chemical changes due to pyrolysis. Undesired decompositions do occur, but are in no wise due to the temperature employed. They occur in the course of the oxidation reactions with unaltered hydrocarbons. Almost no reactions with possibility of commercial outcome take place smoothly without the use of catalysts. Usually metals having multiple and changeable valencies are employed, either as oxides or as salts soluble in the hydrocarbon mixture. Oxides may be used alone, or extended over materials such as pumice in order to present large surfaces. Air is used for oxidation, except in the case of hydrocarbons containing less than 10 carbon atoms. Due to the difficulties of suppressing volatilization of these hydrocarbons, oxygen is used. However, with power at the low price to be obtained in many places adjacent to the sources of petroleum fractions, oxygen can be obtained at a sufficiently low cost.

Pure straight-chain hydrocarbons (paraffin wax) do not require a very high temperature, nor the presence of catalysts, to be oxidized by means of air, nor is any pressure above atmospheric required. However, probably the largest amounts of hydrocarbon to-day are being oxidized by means of air under pressure (15–20 atm.) and at temperatures seldom exceeding 160° C. [4, 1928, 1934].

The average molecular weight of the main body of the product may be controlled in a general way by choosing the fraction of crude. This is only true of low-temperature oxidation. Vapour-phase oxidation produces lower molecular weights than low-temperature liquid-phase oxidation from the same starting material.

Chemical Reactions during Oxidation

Briefly, reactions take place by the simple addition of oxygen to the molecule, and mainly at the beta-carbon atom. Other additions take place later at other locations in the chain or complex. Previous to work by Burwell [3, 1928], practically all the literature assumed that the

reaction leading to the formation of acid was caused by the oxidation of the CH₂ group. It may be observed that at higher temperatures, especially cracking temperatures, the oxidation is such as to attack preferentially the end carbon atom, forming primarily aldehydes [15, 1929, 1931].

From analysis of the final products it was reasoned that practically in no case was the end or methyl group attacked: that the general reaction involved primarily the beta—and secondarily the gamma—carbon atom, and so on towards the centre of the molecule. This would have been observed by the first workers if they had worked with quantities of material sufficient to have discovered the relatively small amounts of volatile acids which are always formed. The first experiments reported by Burwell involved the use of 200 lb. of hydrocarbon mixtures, and it was shortly discovered that commercial uses could be obtained for the products, and oxidation was started on not less than 1,000-lb. charges. It then became immediately apparent that the course of the reaction was as already indicated:

$$2\text{CH}_2\text{CH}_2(\text{CH}_2)_{11}\text{CH}_2\text{CH}_3 + \text{O}_2 \\ = \text{CH}_2\text{CHOHCH}_2(\text{CH}_2)_{10}\text{CH}_2\text{CH}_3 + \\ + \text{CH}_2\text{CH}_2\text{CHOHCH}_2(\text{CH}_2)_{11}\text{CH}_2\text{CH}_3.$$

With the addition of more oxygen these are oxidized to:

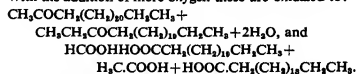

But in the meantime, oxygen has again attacked itself giving:

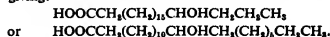

There seems to be no reason why more dibasic acids should not be formed, but only very small amounts have been found, nor do the amounts of formic and acetic acids permit of the formation of dibasic acids. The amounts of the lower molecular weight acids from C₆ up to C₁₀ are small (fractions of 1%), so that they cannot be considered in this connexion.

The acids corresponding to an empirical formula C₁₄H₂₈O₂ contain a hydroxyl group and carbonyl group in addition to the COOH group. The acids with formula C₁₂H₂₄O₂ contain a hydroxyl group; the acids with formula C₁₀H₂₀O₂ contain a carbonyl group; and the acids with formula C₈H₁₆O₂ contain no other oxygen than the carboxylic group. These formulae, it must be understood, do not refer to isolated acids, but to the mixture of acids resulting from the oxidation of the mass and separation.

When it is considered that from 10 to 15% of formic acid and acetic acid is formed, the formic always being in greater quantity than the acetic (equivalent weight considered), it becomes evident that the reaction producing formic acid is more general than that which produces acetic acid.

The main reaction is therefore for the oxygen first to enter the molecule at the beta-carbon in the chain in paraffin wax, assuming the latter to be a straight-chain material. In the course of time, and probably with the introduction of other oxygen atoms into the chain at other points, this particular carbon atom becomes involved in a loss of hydrogen, and becomes a ketone group. Then with sufficient oxygen in solution in the whole mass, under the influence of the general reaction, the chain splits at

the ketone group, with the formation of two acids. As is known, the ketone group almost always goes with the larger molecule, and we have thus formic acid and an acid of higher molecular weight which may be the rest of the hydrocarbon.

Reactions increasing Oxygen in Molecule

During the time that this reaction is taking place other atoms of oxygen are added to the molecules at other points, so that the mixture of acids which is finally recovered is found, from a careful checking of equivalent weights, to have an average equivalent weight of approximately 255 where the material is made from paraffin wax having an average of 24 carbon atoms. Such acids correspond to an average of 12 to 14 carbon atoms when this mixture of hydrocarbons is used.

The production of acids having somewhat more than the average molecular weight, if the chain had split in the centre, is undoubtedly due to the solution or volatilization of the readily water-soluble or volatile acids. This would naturally increase the apparent molecular weight of the mixture of acids remaining insoluble in water.

The main mass of acids derived from paraffin wax of 122 to 124° F. melting-point, averaging around 24 carbon atoms, which have been freed from the accompanying insoluble ketonic alcoholic bodies, will have a molecular weight of 255, as pointed out above. This when figured out for 14 carbon atoms is found to correspond closely, when we consider that we almost invariably have either a ketone group, a hydroxyl group, or both in addition. In such cases, the presence of the hydroxyl group is proved by acetylation, and the presence of the carbonyl group by acetylation, reduction of the mass, and reacetylation, the carbonyl group being reduced to the alcohol group by sodium amalgam in about a week, the reacetylation showing the formation of the additional hydroxyl group.

Care must be taken in making these acetylations to be sure that any lactones which might be formed by reason of the location of the hydroxyl group are held open by forming the esters of the acids which otherwise immediately form lactones upon liberation from their salts.

Products obtained from Low Temperature-Pressure Oxidation in the Liquid Phase

In the wash waters of the oxidation mass are also found lactic acid and several of its homologues, as well as succinic acid and one or two of the other dibasic acids in small quantities. These reactions are easy to construct from the above information.

The main amount of recovered material is about 100% of the original hydrocarbon used, whereas the total product, including water formed by oxidation of the hydrocarbons, would undoubtedly go well over 150%.

The following acids have been separated: formic, acetic, propionic, butyric, valeric, &c., up to and including C_{16} in lessening quantities: none of them is seriously decomposed by boiling at atmospheric pressure.

No attempt has been made to separate these acids more closely by fractionating their esters, but fractions having close to the molecular weight of the acids and boiling-points reasonably close to those given in the literature have been separated. Those derived from paraffin wax have the odour and the appearance of the straight-chain acids. They differ in some other respects because they are never single substances. Even up to C_{16} , as disclosed by their molecular weight, they do not solidify even at low tempera-

tures, the small amount of other impurity doubtless preventing such solidification; it is doubtful if they are more than 90% individuals, if that. Since the lighter distillates which distil up to cracking temperatures from Pennsylvania petroleum are mixtures of straight-chain and branched-chain hydrocarbons, acids made from such hydrocarbons have quite a different appearance, and usually a very strong and disagreeable odour: here again it is even more difficult to separate individuals.

Mixtures can be reproduced of approximately the same equivalent weight at the same temperatures of distillation, but here, too, impurities of other nature are formed and are hard to eliminate. Upon each redistillation more of the materials will break down, particularly at the higher temperatures, and unsaponifiable bodies are formed. Distillation with steam will sometimes give somewhat better odour, and almost invariably better colour, but fractionating in the presence of steam is not satisfactory, and it is more difficult to produce mixtures with any given equivalent properties.

As the loss in manufacture is rather high, the final yield of good coloured, reasonably pure acids, seldom exceeds 60 or 75% of the original hydrocarbon used. They are fairly easy of production, and many uses have been found for them. In particular, acids having boiling-points up to 300° C. have a peculiar property. They do not become much more viscous when cooled to -50° C., and in no case do they become solid. They produce rather attractive-looking, oil-soluble salts of the heavy metals, such as lead, manganese, cobalt, &c., and are used to some extent for making paint driers. As the equivalent weight can be controlled quite readily, it is possible to obtain as much as 40% of actual lead in solution in gasoline.

Ester Formation

The formation of esters is less marked during oxidation under pressure of paraffin wax than it is with most distillates similarly oxidized. In the case of distillates, the saponification to recover the acids must be made with excess alkali and long heating with agitation. Even then a good portion of the ester is not broken up. For instance, after the oxidation mass, which has been oxidized to a point where there is practically no original material left, has been decomposed, the recovery of actual acid with 25% alkali, in considerable excess, does not exceed 35% of the oxidized mass. If, however, this soap be separated, and the remaining part of apparently unsaponifiable matter be attacked with a 50% solution of caustic soda, and at higher temperatures (pressure), another 30% computed on the total mass can be recovered. This would indicate that there is present at least 60 to 75% of esters, as the molecule of alcohol is probably larger than the molecule of acid, on the average. Examination of the reactions will make this plain. This would mean that with 30% free acid it might be possible to have a mixture of esters of secondary alcohols. In all cases lactones are present, but for the purposes of this discussion lactones are considered as esters.

There is another possible reaction which should be given consideration. It has been claimed that some of the higher ketones break up as follows under the influence of strong alkali:

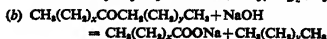

It is known that many esters of the higher alcohols break up upon distillation and form free acids and hydrocarbons [9, 1908; 13, 1923].

However, by returning all unsaponifiable matter which may contain small amounts of unattacked hydrocarbons, but mainly alcohols, ketones, alcohol-ketones, and lactones, it is found that this material, with additional quantities of hydrocarbon, makes an easily oxidized mass. This mass, in turn, is treated in the same way, the oxidation in each case being carried to that point at which initial quantities of the petroleum insoluble, oxidation-mass insoluble materials are formed.

It is these insoluble bodies, out of which it is not easy to recover good quantities of acceptable acids, which cause the greatest losses.

The actual high percentage recovery from oxidation masses is best made by saponifying with caustic soda, returning the unsaponifiable portions, together with new quantities of hydrocarbon, to the oxidizer, decomposing the soaps, and distilling the recovered acids. In this way a somewhat better grade of acid is produced, but the cost of the chemicals for the purpose enhances the cost of the acid to such a point that it is cheaper to lose more of the original mass of oxidized hydrocarbons.

Soaps from Acids produced by Oxidation

The acids produced by the low-temperature oxidation (with pressure) of petroleum hydrocarbons combine with alkalis to form soaps. However, the soaps so produced have the undesirable property of dissolving or emulsifying much of the intermediately oxidized material such as alcohols (poly and simple), ketones, and alcohol-ketones. The only convenient means of separation without decomposition is by the action of immiscible solvents. Even so, the cost is not too high, and from the purified acids valuable soaps can be made. These soaps are especially valuable in the textile industry, as they possess high solvent activity and low surface tension. Such soaps penetrate the yarns, dissolving fats and waxes, thus leaving the fibre in a high state of purity, permitting, for example, of very level dyeing in the piece, and in all cases better and more perfect work.

They have a more rapid and thorough effect than sulphonated castor-oil soaps, and better results than olive-oil soaps. They must, however, be very carefully made, and be free from odour and unsaponifiable residues. They can be made of almost any average molecular weight desired: with low molecular weight they have very superior wetting and penetrating properties.

Most of the soaps have a very disagreeable odour which can however, be modified considerably by steaming the aqueous solution, i.e. long boiling. Another more drastic method which appears to have much promise is to pass steam through masses of the dry soaps held at high temperature [11, 1934].

No satisfactory means has been found for deodorizing the products of vapour-phase oxidations.

Ozone oxidation is controlled by the location of the double bond, and does not produce the enormous number of oxidation products inherent in the two previously mentioned methods. Hence it probably does not give rise to odoriferous products to the same degree. Deodorization is therefore much more easily accomplished. In this connection it may be said that oxidation products made from straight-chain paraffin wax have less offensive odours and

are more easily deodorized or covered than products derived from fractions containing much branched-chain material.

Products Insoluble in Petroleum

The oxidation of petroleum hydrocarbons in the liquid phase under conditions of low temperature with pressure may ordinarily be carried to a point where fully 70% of the weight of the original mass may be extracted in the form of monocarboxylic acids. Many of the molecules will contain one or more hydroxyl groups, and fully half will contain a carbonyl group. The rest of the mass will consist of alcohols (mono and poly) with some ketones and some alcohol-ketones. The whole mass will be soluble in caustic soda (no unchanged hydrocarbons) and in unchanged petroleum fraction (lubrication oils, &c.) practically in all proportions.

However, when petroleum distillates from Pennsylvania crude are oxidized, and the amount of extractable acid has reached a quantity equivalent in weight to 35% of the total original hydrocarbon mixture, material begins to appear which is insoluble in the reaction mass. If at this point the mass is diluted with a large proportion of wholly unoxidized fraction, a considerable amount of precipitate will be formed which consists of a very dark, or black, viscous mass of material consisting almost wholly of acids. If the oxidation of the whole mass is continued from this point, the amount of this insoluble acid material increases, and the amount of petroleum-soluble acids contained in the mass remains nearly constant: the unchanged and only partially oxidized hydrocarbons (alcohols, ketones, and the like) constantly diminish. Therefore, in order to obtain, from a given amount of distillate fraction, the maximum amount of petroleum-soluble acids, it is necessary, either in continuous process or in batch procedure, to remove the partially oxidized mass from the oxidizer, and to remove therefrom the acids, returning the unsaponifiable with added quantities of hydrocarbon to the oxidation. In this way maximum quantities of hydrocarbon-soluble acids can be produced. Conversely, by continuing the oxidation the insoluble acid is formed. This may be removed, and the oxidation continued with fresh portions of the fraction, and the whole eventually converted to the insoluble acids. These acids, when sweetened and esterified (i.e. the methyl or ethyl esters), make excellent softeners for nitrocellulose for the production of artificial leather coatings. These coatings are very stable to air and light, and the proportion of nitrocellulose can be kept very low, with consequent saving in cost.

When these insoluble acids are heated at around 115° C. over long periods they polymerize with very little loss in volume, and eventually solidify on cooling. The product much resembles shellac; it has less physical strength, but it has a higher dielectric strength, and is soluble in many of the same solvents as shellac. Carefully made, it is completely insoluble in water and in oils, and soluble in aqueous alkalis, alcohol, and the usual solvents for shellac.

Other Methods of Oxidation

Many methods for the oxidation of petroleum or similar hydrocarbons have been suggested, most of which, because of high cost of operation or small yields, or both, have not proved to be feasible. However, some of these methods have given interesting results.

For example, ozone has been used for the preparation of acids or aldehydes and ketones [10, 1919] from unsaturated hydrocarbons resulting from the low-temperature

distillation of coal or lignite. Ozonides are formed which upon heating in the presence of water or steam split at the original double bond and are hydrolyzed, forming acids which are separated with hot concentrated caustic potash solution. On hydrolysis of these soaps, principally palmitic and stearic acids are produced. The yield of acids is rather less than 20% of the weight of the original hydrocarbons.

By this method Harries prepared large quantities of fatty ethyl esters which were used for edible purposes in Germany during the latter part of the World War.

The electro-chemical oxidation of oils and paraffin waxes has been reported by Atanasiu [1, 1929, 1931] using sulphuric acid (*d* 1.2) as electrolyte. The paraffins were comparatively easily oxidized, particularly in the presence of 5% potassium dichromate, or 4% ceric sulphate as cata-

lyst. The reaction is really chemical, since the catalyst is alternately reduced and electro-chemically reoxidized. The products obtained were acids, unsaponifiable matter, carbon monoxide, and water, the character of the acids obtained varying with the nature of the paraffin used.

Oxidation methods have been proposed using chemical agents and by photo-chemical means. Nothing of value has been developed along these lines, however, and it is questionable if such methods can be developed.

A great deal of work remains to be done in the field of oxidation of petroleum hydrocarbons, but most of it is to be done in developing means for the separation and purification of the products obtained from oxidizing, rather than in endeavouring to establish complex and frequently uncontrollable methods of oxidation.

REFERENCES

1. ATANASIU, A. *Ber.*, **64**, 252 (1931); *Bull. Chem. Soc. romana stiinta*, **31**, 75 (1929).
2. BITLER, W. P., and JAMES, J. H. *Chem. Met. Eng.* **35**, 156 (1928).
3. BURWELL, A. W. U.S.P. 1,690,768 (1928).
4. ——— U.S.P. 1,690,768-9 (1928); *Ind. Eng. Chem.* **26**, 204 (1934).
5. DANAILA, N., and ATANASIU, A. G.P. 539,472 (1929).
6. DURBS. U.S.P. 1,100,717 (23 June 1934).
7. ELLIS, C. *The Chemistry of Petroleum Derivatives*. The Chemical Catalog Co., 1934.
8. ——— U.S.P. 1,516,720 (25 Nov. 1924), 1,697,262-7 (1 Jan. 1929).
9. ——— U.S.P. 896,093 (1908).
10. HARRIES. G.P. 339,562 (1919).
11. IRTNER, M. H. U.S.P. 1,951,511 (20 March 1934).
12. JAMES, J. H. U.S.P. 1,697,653 (1 Jan. 1929), 1,716,272 (4 June 1929).
13. LEWKOWITZ, J. *Chemical Technology and Analysis of Oils, Fats and Waxes*, 6th ed., 3, 455 (Macmillan, 1923).
14. PENNINGMAN. B.P. 252,327 (1925); B.P. 255,020 (1925); B.P. 256,922 (1925); B.P. 257,886 (1925).
15. POPE, J. C., DYKSTRA, F. J., and EDGAR, G. *J.A.C.S.* **51**, 1875, 2203 (1929); **53**, 3752 (1931).
16. SABATIER, P., and MAILHE, A. *Compt. rend.* **147**, 16 (1908).
17. SCHAAL, E. G.P. 32,705 (25 Sept. 1884); U.S.P. 335,962 (1886).
18. Société Anonyme des Combustibles Industriels: B.P. 16,182 (1905); F.P. 349,214 (1905).
19. WALTER. *J.S.C.I.* **25**, 493, 1173 (1906).

SULPHUR COMPOUNDS

THE SULPHUR COMPOUNDS IN PETROLEUM

By E. EMMET REID, M.A., Ph.D., LL.D.

Professor of Chemistry, Johns Hopkins University

MANY suppositions have been made as to the origin of the sulphur compounds in petroleum. When the origin and history of petroleum deposits are settled we will be in a better position to make definite statements about the sulphur compounds. As petroleum differs radically in character, either their origins or their history must have been different. The same may be said of their sulphur compounds. These differ from each other in kind and widely in amount. Pennsylvania petroleum has only 0.08% sulphur while Mexican may run well over 5%. No narrow theory of formation could be expected to account for all of these variations. Some of the sulphur compounds doubtless come from the materials from which the petroleum was formed. In some cases the sulphur content may have been augmented by the action of sulphur, hydrogen sulphide, or pyrites on the original materials or on the hydrocarbons derived from them, either during the formation of the petroleum or subsequently. Perhaps Pennsylvania oil, and others like it, have been deprived of some of their sulphur compounds by migration through absorptive materials, suggested by Day [26, 1897].

Petroleum is usually assumed to be derived from organic materials either vegetable or animal [117, 1920; 132, 1927]. Both of these contain sulphur compounds. Sulphur is an essential constituent of proteins [81, 1917]. Egg albumin contains 1.62% of sulphur, and legumin from peas 0.38%. As proteins average about 16% of nitrogen to 1% of sulphur a larger proportion of nitrogen compounds might be expected if they were the only source of sulphur. Considerable quantities of organic bases do occur in some petroleum.

According to the inorganic theory, advocated by Sabatier [87, 1922], petroleum has been derived from acetylene and other hydrocarbons and hydrogen formed by the action of water on calcium, aluminium, and iron carbides and metals. In the presence of nickel and other catalysts the acetylene is supposed to have been more or less hydrogenated and polymerized. If hydrogen was in excess, the saturated hydrocarbons would result, otherwise there would be more or less aromatics. Sulphur, possibly from pyrites, may have taken part in these reactions. Steinkopf [107, 1922; 108, 1914] has obtained thiophen and its 2- and 3-methyl, its 2- and 3-ethyl derivatives by passing acetylene over hot pyrites. Miss Tomkinson [114, 1924] and Broun [11, 1933] obtained high yields of thiophen and its homologues by passing these gases over various catalysts.

Petroleum is frequently found saturated with hydrogen sulphide [3, 1925]; Persian natural gas contains 12-13% of it. Cadman [12, 1925] attributes this to the action of hydrocarbons on gypsum which he finds to be abundant in the rock layers above the gas reservoirs. He passed sulphur-free natural gas through heated anhydrite and got hydrogen sulphide and unsaturated hydrocarbons. Friedmann [42, 1930] is sure that 'the traditional view that the reduction of sulphates to sulphur by dead organic material can take place

is to be discarded', since the temperatures required are out of the question, while the bacteria that might accomplish this 'thrive best at temperatures of 25-30° C. such as are to be found in wells'. He states that anaerobes related to *Spirillum desulphuricans* are found in many borings, which substantiates the hypothesis of Kraemer and Spilker [60], put out in 1902, that the sulphur compounds of petroleum have been formed by bacterial activity.

Richardson and Wallace [85, 1902] observed the deposition of sulphur from a Beaumont crude that had been passed through kaolin. This oil evolved hydrogen sulphide on heating. Sulphur crystals were present in the adjacent limestone. Thiele [111, 1901] reports the presence of an immense sulphur deposit directly above the oil in the Beaumont field. He [112, 1902] analysed a deposit from a tank car of this oil and found it to contain 63.63% of amorphous sulphur and 6.81% of crystalline sulphur. Comment has been made on the simultaneous presence of the two forms of sulphur. The crystals may represent sulphur which had been in solution in the oil, while the amorphous may have come from the action of air on hydrogen sulphide.

It is known that sulphur reacts with hydrocarbons saturated, unsaturated, aromatic, or hydroaromatic [11, 1933; 43, 1925]. Victor Meyer [71, 1883] passed ethylene through hot sulphur and obtained hydrogen sulphide, carbon disulphide, and thiophen. Challenger and Harrison [18, 1925] found not only thiophen, but its more complicated derivatives when acetylene was passed through boiling sulphur. From sulphur heated in a sealed tube with ethyl-benzene the yield of 2,4-diphenyl-thiophen was excellent [44, 1929]. Similarly, Friedmann [39, 1916] obtained C_8H_8S and $C_8H_6S_2$ from *n*-octane. One of these was a thiophen derivative, while the other probably contained two thiophen rings fused together. Better yields were obtained from 2-octene [41, 1916]. From β -methyl-naphthalene [40, 1916] a crystalline compound, $C_{12}H_8S$, was obtained. Recently Shepard, Henne, and Midgley [100, 1934] passed butadiene, isoprene, and 2,3-dimethyl-butadiene through sulphur kept at 350° C. The yields were 6% thiophen, 31% of 3-methyl-thiophen, and 47% of 3,4-dimethyl-thiophen. Mailhe [69, 1934] found that by passing ethylene, propylene, butylene, or amylene with hydrogen sulphide over heated silica gel saturated, unsaturated, and aromatic hydrocarbons are formed, together with a whole series of sulphur compounds, carbon disulphide, mercaptans, alkyl sulphides, and thiophens.

Guislin [48, 1913] found the solubility of sulphur in light petroleum distillates to be 1.5% at 70° C. On cooling such a solution sulphur crystallizes out, but on distilling it hydrogen sulphide is evolved. He found little reaction between purified kerosine and sulphur when they were boiled together, but in a sealed tube at 200° C. there was considerable action. Naphthenic acids were found to be particularly reactive with sulphur, which led him to attribute

the action of sulphur on petroleum chiefly to the naphthenic acids present.

Rakusin [83, 1922] found sulphur to react with paraffin wax at 200° C. with evolution of much hydrogen sulphide. Siebeneck [101, 1922] experimented with the same materials over a wider temperature interval. The evolution of hydrogen sulphide began at 150° C., and partial carbonization took place on long heating at 230° C. Brooks and Humphrey [10, 1917] recommended this as a preparation method for hydrogen sulphide.

Richardson [84] studied asphalts in 1897 and concluded that sulphur has had an important part in their formation. He found that when Trinidad asphalt is heated carbon dioxide is eliminated and then hydrogen sulphide. Friedmann [37, 1916; 38, 1916] agreed with this conclusion and tested it by heating indene with sulphur; a material with all the characteristics of asphalt was obtained.

Little is known about the addition of hydrogen sulphide or sulphur to unsaturated hydrocarbons. Such additions do take place and mercaptans and sulphides are formed. We do know that sulphur is taken up by pinene, on moderate heating, without the evolution of hydrogen sulphide. Addition reactions, particularly with hydrogen sulphide, should go on at much lower temperatures than those mentioned above. It is generally believed that petroleum deposits have not been subjected to high heat either during or after their formation. Mabery [64, 1896] cites in support of this view the fact that oil-soaked tree-trunks have been excavated. It is well known that the sulphur compounds in petroleum are predominantly aliphatic, while coal tar and shale oil, both pyrogenetic products, contain the thiophenes. No relationship has been established between the shale oil and the sulphur compounds originally in the shale [52, 1926]. Shale oils are particularly high in sulphur [24, 1921; 70, 1910].

Alkyl sulphates have been found in gasoline [55, 1904], but these must have been introduced in the refining.

Derived Sulphur Compounds

Emphasis is put by von Braun [7, 1931] on the present-day recognition of the fact that the simple sulphur compounds, mercaptans, sulphides, thiophenes, thiophanes, and the like, 'do not preexist in the petroleum but are formed only in the heating and distillation of the petroleum, perhaps by the decomposition of complicated mother substances, perhaps by the interaction of sulphur or hydrogen sulphide and hydrocarbons. However interesting the study of these compounds may be it has little to do with the investigation of the original hydrocarbon constituents of petroleum; a direct, readily recognized connexion is lacking.' There is no relation of the sulphur in coal gas to that in the coal [25, 1923]. Siegfried [49, 1913; 102, 1911] cites a very heavy petroleum which when distilled at ordinary pressure gave 22.3% of distillate with 10-15% sulphur with the evolution of much hydrogen sulphide, but at 7 mm. pressure 35% of distillate with only 2.5% of sulphur. The latter distillation must have left most of the sulphur in non-volatile compounds in the residue.

Chemists are quite accustomed to seeing things come out of a kettle that are very different from the ingredients that were put in. It is frequently a chemist's business to see that this takes place. Shale oil is distilled from shale, though there is no more oil in oil shale than there is shale in shale oil. A Persian petroleum examined by Birch and Norris [3, 1925] contained much hydrogen sulphide which was readily dissipated by exposure to the air. When this was

gone the crude had a pleasant odour with no suggestion of mercaptans, but distillation gave 36% of this as a naphtha, from which caustic soda extracted ethyl, isopropyl, and isobutyl mercaptans.

In the distillates from petroleum, shale oil, and coal tar three great classes of hydrocarbons are found: aliphatic, aromatic, and hydroaromatic or naphthenes. In these distillates are found the corresponding three classes of organic sulphur compounds. The aliphatics are represented by mercaptans, sulphides, and disulphides, the aromatics by thiophen and its homologues, and the naphthenes by cyclic polymethylene sulphides. In a given distillate the nature of the sulphur compounds agrees in the main with that of the hydrocarbons. An extreme case is that of the light oil from coal tar which is almost exclusively aromatic and in which the only sulphur compounds (other than carbon disulphide) are the thiophenes. In shale oil [106, 1927; 126], though it contains a considerable proportion of aliphatic hydrocarbons, the same thiophenes are found. Coal tar and shale oil are alike in that they are both produced at high temperatures at which the thiophenes are about the only stable sulphur compounds. Charitschkoff [21, 1899] found thiophen along with benzene in Grosny petroleum.

A sulphur balance taken between a crude oil and the distillates plus the residue that are obtained from it always shows a loss of organic sulphur. More or less of the combined sulphur comes out as hydrogen sulphide. Sissingh [103, 1925] has made such calculations on Mabery's results and on distillations of his own. He finds a 9% loss in one case and a 14.9% in another. Cooney [23, 1928] finds that much of the sulphur in the oil is liberated as hydrogen sulphide.

Shatwell [99, 1925] cracked a shale-oil fraction, 10.08% sulphur, and thereby reduced its sulphur to 5.93%. Facts like these are of great importance to present-day refiners; cracking converts much of the sulphur to hydrogen sulphide and the lower mercaptans which are readily taken out of the naphthas.

Distribution of Sulphur Compounds

It is noteworthy that, when a sulphur-containing oil, whether it be a petroleum, a shale oil, or distillate from a tar of any kind, is fractionated, no matter how many or how close the cuts, every cut shows the presence of sulphur compounds [81, 1917]. In the case of a shale oil [19, 1926] or a tar oil [54, 1895] there is apt to be a higher sulphur content in the cuts which include the boiling-points of the thiophen homologues, but with petroleum the sulphur compounds are rather evenly distributed. The figures below illustrate this. Franks [36, 1921] gives sulphur analyses of the fractions of four petroleum of which 10% cuts were made.

Percentage of Sulphur in Fractions

No.	A	B	C	D
1	0.48	0.64	0.30	0.67
2	0.65	0.70	0.49	0.77
3	0.63	0.69	0.59	0.77
4	0.61	0.68	0.68	0.76
5	0.60	0.66	0.69	0.74
6	0.57	0.66	0.68	0.71
7	0.49	0.64	0.62	0.64
8	0.38	0.54	0.57	0.45
9	..	0.39	0.52	0.30
10
Original	0.64	0.77	0.61	0.75

It appears that the sulphur content remains nearly constant for the middle fractions and is a little lower in the first and last. A sulphur balance was struck and it was found that only 71% of the sulphur in the whole oil appeared in the fractions.

Perkin [81, 1917] distilled an American crude at atmospheric pressure and found:

Fraction	% S	Fraction	% S
90° C.	0.02	220-257° C.	0.41
110-150° C.	0.10	257-300° C.	0.37
152-220° C.	0.38	300-350° C.	0.37
		Residue	0.54

Ruhemann and Rosenthal [86, 1923] fractionated brown coal tar at 12 mm. All fractions contained sulphur, starting with 3.46% and diminishing with the higher.

Similar results were obtained by Fürth and Jaenicke [43, 1925] with brown coal tar oils:

Fraction	% S	Fraction	% S
160° C.	1.26	210-220° C.	0.90
160-170° C.	1.24	220-230° C.	0.96
170-180° C.	1.09	230-240° C.	0.97
180-190° C.	0.88	240-250° C.	1.58
190-200° C.	0.83	250-up° C.	1.71

Analogous figures for low and high sulphur crudes are given by Kauffman [57, 1928].

A Mexican crude with 3.77% sulphur was examined by Smith and Stark [104, 1924]. The gasoline fraction up to 190° C. was 12% and contained only 0.39% sulphur, but the gas evolved contained much hydrogen sulphide. The kerosine fraction 16.5% contained 1% sulphur. One portion of the remaining oil gave 14% of gas oil with 2.68% sulphur and a residue of 52.5% with 5.1% sulphur. The gas evolved contained 21% of hydrogen sulphide. Another portion underwent a coking distillation and yielded 44% of cracked distillate with 2.48% sulphur and 17.5% of coke with 6.23% sulphur. This illustrates two things which are common: the loss of a considerable part of the sulphur during distillation, and the accumulation of sulphur compounds in the higher fractions and residue. The gasoline fraction of this 'cracked distillate' showed 2% of sulphur, which contrasts with the 0.39% in the corresponding fraction from the whole oil. This indicates that the sulphur was originally in complex, non-volatile compounds.

Egloff and Morrell [33, 1923] ran a Mexican gas oil (2.19% sulphur) through a Dubbs cracking still at 800° F. (467° C.) and 120 lb. pressure, obtaining 50% of its volume as 'pressure distillate'. This accounted for 23% of the sulphur present, the residuum for 62% more, while 12.9% escaped as hydrogen sulphide. They say: 'On a basis of actual percentage of sulphur in the primary products of cracking hydrocarbon oils, the content of sulphur increases with the density of the liquid and solid products, but is higher in the gas than in any of the other products.' A shale oil distilled by Shatwell [99, 1925] gave opposite results. The crude had 6.81% sulphur and the fractions from it: 175° C. 10.08%, 175-300° C. 7.44%, and the residue 6.11%. Shale oils from various localities were fractionated by Helsing [53, 1921] into 25 cuts, 75 to 330° C. All contained sulphur which was higher in the higher cuts.

The persistence of sulphur compounds in all fractions is illustrated by the work of Weissgerber [61, 1901; 119, 1921] on coal tar. He found the following percentages of sulphur:

Sulphur in Coal-tar Fractions

Fraction	Boiling range	% sulphur
Light oil	80-200° C.	0.19
Carbolic oil	180-220° C.	0.58
Naphthalene oil	200-265° C.	1.02
Anthracene oil	260-340° C.	0.89
Crude naphthalene	..	0.69
Crude anthracene	..	0.17

He identified thionaphthen, the sulphur analogue of naphthalene, a thiophen ring fused to a benzene ring, in crude naphthalene. Two methyl derivatives of thionaphthen, melting at 52° C. and 36° C., were found along with the methyl-naphthalenes. In crude anthracene he found diphenylene sulphide, which is anthracene with its middle ring replaced by thiophen. This was also found by Kruber [62, 1920]. Long before it had been found in crude fluorene by Kraemer and Weissgerber [61, 1901].

These facts are readily understood when we consider the boiling-points of the members of the different series. The boiling-points of a number of hydrocarbons and mercaptans are given in the table below. It will be seen that a normal mercaptan boils at very nearly the same temperature as the normal hydrocarbon with three more carbon atoms. Thus *n*-amyl mercaptan boils at 126.5° C. and *n*-octane at 125.5° C. Our knowledge of the thiophen homologues is much less complete and the comparison is complicated by isomerism, but so far as our figures go there is a thiophen boiling near to each aromatic hydrocarbon from which it is extremely difficult to separate it by distillation. The data are given below.

Boiling-points of some Hydrocarbons and Mercaptans [34, 1932]

Hydrocarbons	Mercaptans
<i>n</i> -Butane 0-5° C.	Methyl 7.3° C.
<i>n</i> -Pentane 36.1° C.	Ethyl 34.7° C.
<i>i</i> -Hexane 60.2° C.	<i>i</i> -Propyl 58° C.
<i>n</i> -Hexane 68.8° C.	<i>n</i> -Propyl 68° C.
<i>n</i> -Heptane 98.4° C.	<i>n</i> -Butyl 98° C.
<i>n</i> -Octane 125.5° C.	<i>n</i> -Amyl 126.5° C.
<i>n</i> -Nonane 149.8° C.	<i>n</i> -Hexyl 151.5° C.
<i>n</i> -Decane 173.2° C.	<i>n</i> -Heptyl 176.2° C.
<i>n</i> -Undecane 195.8° C.	<i>n</i> -Octyl 199.2° C.
<i>n</i> -Dodecane 216.2° C.	<i>n</i> -Nonyl 220.4° C.

Boiling-points of some Benzene and Thiophen Derivatives [94, 1920]

Benzene 80.1° C.	Thiophen 84° C.
Toluene 110.6° C.	2-Methyl Thiophen 113° C.
Ethyl-benzene 136.1° C.	3-Ethyl Thiophen 135° C.
<i>m</i> -Xylene 139.3° C.	2,4-Dimethyl Thiophen 137° C.
<i>p</i> -Xylene 138.4° C.	2,5-Dimethyl Thiophen 135° C.
Propyl-benzene 159.4° C.	2-Propyl Thiophen 158° C.

Early Investigations

An early study of sulphur compounds was made in 1879 by R. Kayser [58, 1895] as quoted by Day. He fractionated Syrian asphalt oil, segregated and analysed a number of fractions which he took to be pure compounds. The boiling-points of these range from 96 to 265° C. He assigned them formulae to fit his analyses without paying any attention to molecular weights or boiling-points. Thus his lowest compound, boiling at 96° C., comes out as C₁₃H₁₆S. This looks like a higher homologue of Mabery's 'thiophanes' C₆H₁₂S, C₈H₁₆S, and C₁₀H₁₆S, but these boil at 184 and 207° C. respectively, while thiophane, C₄H₄S, the lowest

member of this group, boils at 119° C. The $C_{14}H_{28}S$ should boil at about 230° C. His 'compound' was evidently a mixture of hydrocarbons with sulphur compounds. The boiling-point 96° C. suggests *n*-heptane, b.p. 98.4° C., and *n*-butyl mercaptan, b.p. 98° C. His formulae for his higher 'compounds', such as $C_{10}H_{20}S$ for the 188° C. fraction, are even more out of line, as a hydrocarbon of this boiling-point could not possibly have more than 10 carbon atoms or 1 sulphur and 7 or 8 carbons in its molecule. While his formulae are fantastic his results do agree well with those of all subsequent investigations in that the sulphur compounds are distributed over the whole boiling range. Of his fractions from 158 to 265° C., the lowest sulphur content was 5.52% and the highest 6.27%. No one, even with modern precision stills, has been able to isolate the sulphur compounds by fractionation alone.

In 1900 Edeleanu and Filitti [32] wrote that 'sulphur is present in petroleum in small quantity but in what combinations is not known. The conclusions drawn up to the present are contradictory or not well founded.'

Sulphur and Hydrogen Sulphide

Both of these are frequently found in petroleum and are closely associated with the organic sulphur compounds either as precursors or as decomposition products. They both appear in petroleum distillates [2, 1927] as both may be decomposition products of organic sulphur compounds. Sulphur may be set free by the oxidation of hydrogen sulphide, and, as shown above, hydrogen sulphide may result from the action of sulphur on hydrocarbons. Richardson and Wallace [85, 1902] found that Beaumont (Texas) oil contained much hydrogen sulphide and deposited sulphur after aeration. Natural gas from some sources contains much hydrogen sulphide. Tervet [109, 1882] reports sulphur in shale naphtha and Kehlstadt [59, 1880] observed its appearance during the dry distillation of coal-tar oils. Dudenko [28, 1931] found it in cracked distillate. Dunstan and Brooks [30, 1922] report hydrogen sulphide in petroleum from Canada, Ohio, Texas, Galicia, and Persia. Sulphur in fuel oil is discussed by Dunlap [29, 1927], also by Gookhmann and Kammer [45, 1927].

Carbon Disulphide

Carbon disulphide has been reported in petroleum and its distillates from time to time, but little can be said about it. It is a well-known constituent of coal gas [46, 1883; 78, 1925]. We have an old statement by Hager in 1867 [51]: 'It is rare to find commercial petrols or benzinnes which do not contain a certain quantity of carbon disulphide—the product known as "essence de pétrole", boiling 50–80° C., from American petroleum is the one that contains the most, those boiling above 80° C. have little.' It is a curious fact that so little is known about its presence or absence. According to Wood, Sheely, and Trusty [131, 1926] it is not taken out by sulphuric acid or by any of the other refining agents.

Mercaptans

Although the presence of mercaptans in petroleum distillates has long been accepted and refining processes have been directed towards their elimination, Birch and Norris [3] in 1925 seem to have been the first to isolate and identify them. The 'spent soda' from the purification of the first 36% distilled from Persian petroleum was steam distilled. From 40 gal. of the spent soda 720 c.c. of sulphur oil was obtained. This was extracted with 50% caustic

potash solution from which the dissolved mercaptans were recovered by acidification. This mixture was steam distilled and 350 c.c. of mercaptan mixture was obtained. Fractionation proved this to be mainly isopropyl and isobutyl mercaptans with a small amount of ethyl and some of a higher mercaptan which they assumed to be isoamyl. The isopropyl and isobutyl mercaptans were positively identified by boiling-points, analyses, and the melting-points of solid derivatives.

The oil which was not dissolved by the caustic soda solution was fractionated and proved to contain large amounts of ethyl, isopropyl, and isobutyl disulphides. The appropriate fractions were reduced with zinc dust and acetic acid and the resulting mercaptans identified. They believed that the disulphides had been formed from the sodium mercaptides originally present in the caustic soda wash by oxidation, either by air or by sodium polysulphides. They seem to have proved this to be correct.

They give an interesting table showing the percentage of mercaptan extracted from 200 c.c. of a 0.05 molar solution of a mercaptan in light petroleum by 80 c.c. of 5% sodium hydroxide solution (about 125% excess).

Mercaptan	% extracted	Mercaptan	% extracted
Ethyl	97.1	<i>n</i> -Butyl	63.2
<i>n</i> -Propyl	88.8	<i>i</i> -Butyl	62.8
<i>i</i> -Propyl	87.2	<i>i</i> -Amyl	33.0

They speak of 'the obvious decrease in the acidity of the mercaptans with increasing molecular weight . . .'. It seems unlikely that there is any real difference in 'acidity' between the higher and lower mercaptans, but there are great differences in their solubilities in water and in their partition coefficients between water and a hydrocarbon.

Birch and Norris point out that the mercaptans were not present in the original Persian petroleum. When it came from the well it was accompanied by much gas, a large part of which was hydrogen sulphide, but after this escaped its odour was faint and somewhat sweet. They suggest that the mercaptans may have been formed by the addition of hydrogen sulphide to unsaturated hydrocarbons.

Very similar information is given by Wiewiecz, Turner, and Frolich [125, 1933], but from refinery practice where the mixture of mercaptans is recovered. They give the composition as 30% methyl mercaptan, 53% ethyl, and 17% of higher. As methyl mercaptan boils so low (7.3° C.) it is easily lost from the mixture.

Working under Project 28 of the American Petroleum Institute's research programme, L. M. Ellis, Jr., made the following partition measurements. (See Table on next page.) A hydrocarbon solution of the mercaptan was shaken with an equal volume of water or aqueous caustic soda at 25° C. It will be noticed that the percentage extracted decreases rapidly from methyl to nonyl. The secondary mercaptans, though more soluble in water than the normal, are harder to extract with alkali, indicating that they are less acidic. It is easier to extract a mercaptan from heptane than from benzene.

Dudenko [28, 1931] reports mercaptans in a cracked distillate. Nametkin and Sosnina [77, 1934] found them in the kerosine from Perm oil.

The presence of mercaptans was assumed in a hazy sort of way by Tervet [109, 1882], who was considering the appearance of sulphur in the distillation of shale naphtha which had been treated with sulphuric acid. He quotes an unnamed chemist as suggesting that the sulphur comes from 'a hydrocarbon disulphide, which undergoes decomposition

in the process of distillation'. Tervet then says: 'This view is perhaps supported by the observation of R. Otto [79, 1880] that aromatic mercaptans are converted into disulphides by the action of sulphuric acid; and this suggests the question—May not the sulphur compounds present in the crude naphtha be similarly affected by sulphuric acid?'

Percentage of Mercaptans in Aqueous Layer

Mercaptan	Benzene %	Benzene %	Heptane %
	Water	0.62 N. NaOH	0.62 N. NaOH
Methyl	5.67	97.9	99.6
Ethyl	2.14	94.5	98.1
<i>n</i> -Propyl	0.32	77.4	86.7
<i>n</i> -Butyl	0.08	47.2	64.8
<i>n</i> -Amyl	0.022	19.3	38.5
<i>n</i> -Hexyl	0.007	6.30	5.57
<i>n</i> -Heptyl	..	1.80	2.16
<i>n</i> -Octyl	..	0.50	0.76
<i>n</i> -Nonyl	..	0.21	0.27
Isopropyl	0.44	78.50	..
<i>s</i> -Butyl	0.11	45.34	..
<i>s</i> -Amyl	0.028	16.77	..
<i>s</i> -Hexyl	0.008	5.33	..
<i>s</i> -Heptyl	..	1.35	..
<i>s</i> -Octyl	..	0.35	..
<i>s</i> -Nonyl	..	0.16	..

Parrish and Rowe [80, 1926] found that 20% of the sulphur compounds in a low-temperature tar oil were mercaptans. Schütz [96, 1923; 97, 1923; 98, 1923] considers this tar to be similar to Baku petroleum. He found in it methyl mercaptan and methyl sulphide and their homologues. These were separated by fractionation and identified by their boiling-points and transformation of the sulphides into sulphones.

Hackford [50, 1926] isolated 'dimercaptans' from Mexican oil. When these were heated to 165°C. one-half of the sulphur was lost and the other half remained in the thiophen condition. It is hard to see that these could have been. A dimercaptan, HS(CH₂)₂SH, might split off hydrogen and hydrogen sulphide to give a thiophen, but this has not been proved.

Of all the sulphur compounds in petroleum distillates the mercaptans give the refiner the most trouble. They impart unpleasant odours to his products, and are generally blamed for corrosion. A naphtha containing mercaptans is said to be 'sour' and to be 'sweetened' when they are removed. In the old days of 'straight run' gasolines which contained only small amounts of unsaturates, agitation with concentrated sulphuric acid took out mercaptans along with the other sulphur compounds. At the present time, when sulphuric acid cannot be liberally used on account of the high losses involved [33, 1923] other means of refining have been adopted. These are directed to a removal of mercaptans. Cracking decomposes the sulphur compounds, as well as the higher hydrocarbons, converting them largely into hydrogen sulphide and mercaptans. The hydrogen sulphide is easily removed by agitation with caustic soda solution, and so are the lower mercaptans, as may be inferred from the table given above. Methyl mercaptan is even more readily removed than ethyl. As seen from the table, butyl and amyl mercaptans are only partially removed by a single washing and require repeated treatment. The higher mercaptans, hexyl to nonyl (b.p. 220-4°C.), are hardly extracted at all by caustic soda solution. The naphtha after the alkali wash is 'sweetened' by the 'Doctor' treatment described by Wendt and Diggs [124, 1924]. This does not diminish its sulphur content, but does eliminate the

disagreeable odour by converting the mercaptans into the much higher boiling and less obtrusive disulphides.

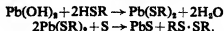

Pressure distillates may contain more than enough sulphur to complete the reaction. The hypochlorite treatment accomplishes the same end [115, 1924]. Refining has been effected in that sourness has been eliminated. Silica gel removes mercaptans [116, 1925]. Specifications call for less than 0.10% of sulphur in gasoline. This must include the sulphur in the disulphides in addition to that in sulphides, thiophanes, and thiophens. Starting with a high sulphur crude, the possibility of complying with the specifications depends on the completeness of the cracking of other sulphur compounds into the easily removable hydrogen sulphide and lower mercaptans. In some cases it is not practicable to bring the sulphur in a naphtha low enough. Then blending with a low sulphur naphtha may save the day. Alkyl disulphides and sulphides, thiophanes and thiophens are unreactive and unobtrusive and are considered unobjectionable within the narrow limits of 0.10% of total sulphur. Munsell [75, 1926] writes of a Texas Panhandle crude with over 2% of sulphur 'which in the process of refining is converted into free sulphur, hydrogen sulphide and other sulphur compounds'. Treatment with caustic soda solution followed by lead oxide cleans up the sulphur compounds.

Alkyl Disulphides

The presence of disulphides in transformer oils has been shown by Ferber [35, 1928]. By treating 6 kg. of an oil with sodium a solid mass was obtained which was separated and washed with petroleum ether. The dark-grey mass was exposed to the air for several weeks, mixed with petroleum ether, and acidified. The petroleum ether solution was separated, dried, evaporated, and the 28 g. residue heated in a distilling flask. Nothing came over below 259°C., and decomposition set in at 262°C. This oil contained 25.86% of sulphur. It was reduced in alcoholic solution and 18 g. of oil isolated which was almost entirely soluble in strong alkali and began to boil at 96°C. It was separated into three fractions:

- I. 127-130°C. at 722 mm., d. 0.859₁₅, n_D^{20} 1.459;
- II. 176-178°C. at 722 mm., d. 0.861₁₅, n_D^{20} 1.522;
- III. 201-204°C. at 722 mm., d. 0.862₂₀, n_D^{20} 1.469.

These constants and complete analyses identified these as *n*-amyl, *n*-heptyl, and *n*-octyl mercaptans, the correct boiling-points of which are 126.5, 176.2, and 199.1°C. [34, 1932]. The proof is certainly clear that these were not present in the transformer oil as mercaptans, but that these mercaptans came from disulphides which were present. Ferber does not raise the question as to whether they may not have been present originally as mercaptans and been oxidized to the disulphides during the refining operations.

Disulphides, which they attributed to the oxidation of mercaptans, were found by Birch and Norris [3, 1925]. As refining treatments and even oxidation by air, particularly in the presence of alkali, produce disulphides they are commonly present in gasolines, but there is no evidence to show that they are present in crude petroleum or in the primary products of distillation or of cracking.

Alkyl Sulphides

For a serious start on the isolation and identification of sulphur compounds we must go back to Mabery [63, 1895;

64, 1896; 65, 1900; 66, 1906], who studied the Lima oil from Ohio and a Canadian oil. In his first papers [67, 1891; 68, 1894] he gives his results with the Lima oil. He took 50 litres of the sludge acid 'that had recently been used in refining Lima burning oil' distilled and neutralized it cold with slaked lime. He steam distilled the resulting mixture and obtained 2,270 g. of oil containing 14.97% sulphur. This he fractionated at 150 mm. 22 times, the last distillation being at 100 mm. The following fractions were obtained:

Fraction, °C.	-76	80-90	98-101	135-145	148-155	185-200
% Sulphur	2.60	7.34	18.23	15.52	16.44	14.21

From the fraction, 95-100°C. at 100 mm. the sulphur compound was precipitated with mercuric chloride and liberated with hydrogen sulphide. It then boiled at 156-160°C. and had a sulphur content corresponding to 'ethyl-pentyl' sulphide. The sulphur compound similarly obtained from the 110-115°C. at 100 mm. fraction boiled at 170-6°C. and had the correct sulphur content for isobutyl sulphide (b.p. 172°C.). The sulphur compound from the 117-25°C. at 100 mm., distilled at 180-5°C., and corresponded in percentage of sulphur and boiling-point to *n*-butyl sulphide (b.p. 182°C.). Butyl-pentyl, pentyl, and hexyl sulphides were similarly identified.

This pioneer investigation is very important, but the identification of the higher sulphides by boiling-points and sulphur analyses only leaves much to be desired. A detailed identification was made on another oil from Findley, nearly all of which distilled below 150°C. This was agitated thoroughly, 5 litres at a time, with aqueous mercuric chloride. The precipitate was filtered off and subjected to heavy pressure in a screw press. The dried precipitate was decomposed by hydrogen sulphide in the presence of alcohol. The alcoholic filtrate was diluted with water and the oil separated, washed, and dried. The oil was then fractionated repeatedly. A small fraction collected below 50°C. gave a sulphur analysis corresponding to methyl sulphide. A fraction 89-92°C. had a sulphur content corresponding to ethyl sulphide 98% pure. A fraction 110-112°C. gave a nearly correct sulphur analysis for propyl ethyl sulphide and a platinum chloride addition product with the proper analysis for the same. Nothing could be obtained corresponding to isopropyl sulphide, but *n*-propyl sulphide was readily identified in the 127-132°C. fraction by analysis of the oil and of its platinum chloride compound.

Schütz [97, 1923] found sulphides in low-temperature tar. Tervit in 1882 [109] believed the sulphur compounds of shale naphtha to be chiefly sulphides, but did not identify them.

The work of Thiery [113, 1925] is practically a continuation of that of Mabery. He started with 22 litres of the sludge acid from the refining of Persian petroleum. By dilution with water and extraction he obtained 1,800 c.c. of oil which was fractionated, that boiling up to 100°C. 4 times at atmospheric pressure and the higher part 11 times at 125 mm. The final fractions are given in the next column. Before fractionation the oil was extracted with alkali.

The figures illustrate the statement, made above, that the sulphur compounds form a continuous series. Only four of these fractions were further investigated. Fraction 4 contained 61% chloroform which had been used in the extraction; the rest was methyl ethyl sulphide which was positively identified by the two derivatives $\text{Hg}_2\text{SC}_2\text{H}_5 \cdot \text{HgI}_2$, m.p. 59°C. and $(\text{CH}_3)_2(\text{C}_2\text{H}_5)\text{SI} \cdot \text{HgI}_2$, m.p. 86°C., the melting-point of both of which agree exactly with data

from the literature. Fraction 7 had the right boiling-point and nearly the correct composition for ethyl sulphide, but crystalline derivatives showed it to be something entirely different. Fraction 11 was proved to be tetramethylene sulphide and fraction 17 to be pentamethylene sulphide. These results fit in nicely with those of Mabery. Here we have both sulphides and thiophanes in the same oil, while Mabery found them in different.

No.	B.p. range °C.	Vol.	No.	B.p. range °C.	Vol.	No.	B.p. range °C.	Vol.
1	-50	0.5	11*	63-66	20	21	93-96	12
2	59-64	90	12	66-69	5	22	96-99	9
3	64-68	11	13	69-72	3	23	99-102	19
4*	68-70	23	14	72-75	5	24	102-105	28
5	70-80	10	15	75-78	10	25	105-108	16
6	80-89	8	16	78-81	7	26	108-111	14
7*	89-92	11	17*	81-84	75	27	111-114	35
8	92-100	7	18	84-87	10	28	114-117	20
9	-60	4	19	87-90	3	29	117-120	18
10	60-63	12	20	90-93	30	30	Residue	..

Kan [56, 1927] obtained $\text{C}_8\text{H}_{16}\text{S} \cdot \text{HgCl}_2$ and $\text{C}_{11}\text{H}_{20}\text{S} \cdot \text{KglCl}_3$ by treating fractions of a cracked distillate with alcoholic mercuric chloride, thus identifying methyl and ethyl sulphides. Similar derivatives were obtained from higher fractions.

Sulphides are oxidized to sulphones by hypochlorite [4, 1925].

Thiophanes

Mabery and Quayle [65, 1900; 66, 1906] examined a Canadian petroleum and isolated a number of high-boiling sulphur compounds. A barrel (225 litres) of the sulphur oil was distilled, 10 litres at a time in porcelain stills, up to 250°C. at 50 mm. and the fractions redistilled several times. Each fraction was agitated with alcoholic mercuric chloride. The precipitate was collected, washed thoroughly with petroleum ether and alcohol, and decomposed in alcohol suspension with hydrogen sulphide. The sulphur oil was thrown out by dilution and reprecipitated by mercuric chloride. The addition product was treated as above and the separated oil collected and fractionated. Thus they obtained a succession of 'thiophanes'. The properties of these were as follows:

From fraction	B.p. °C.	D. at 20° C.	Ref. Ind.	Composition	Name
71-3° C. at 50 mm.	158-160	0.8778	1.468	$\text{C}_8\text{H}_{16}\text{S}$	heptyl
79-81° C. "	167-169	0.8929	1.4860	$\text{C}_9\text{H}_{18}\text{S}$	octyl
91-99° C. "	183-185	0.8937	1.4766	$\text{C}_{10}\text{H}_{20}\text{S}$	iso-octyl
106-108° C. "	193-195	0.8997	1.4766	$\text{C}_{11}\text{H}_{22}\text{S}$	nonyl
114-115° C. "	207-209	0.9074	1.4766	$\text{C}_{12}\text{H}_{24}\text{S}$	decyl
135-145° C. "	228-230	0.9147	1.480	$\text{C}_{13}\text{H}_{26}\text{S}$	undecyl
160-170° C. "	266-268	0.9208	1.4892	$\text{C}_{14}\text{H}_{28}\text{S}$	quadecyl
170-180° C. "	283-285	0.9222	1.4903	$\text{C}_{15}\text{H}_{30}\text{S}$	pentadecyl
191-210° C. "	290-295	0.9235	1.4977	$\text{C}_{16}\text{H}_{32}\text{S}$	octadecyl

These were oxidized to sulphones which were all thick oils.

Challenger [16, 1929] found tetrahydrothiophen, or thiophane, $\text{C}_4\text{H}_8\text{S}$, in the aqueous mercuric acetate mother liquor after the separation of 2-methyl-thiophen from the 109-117°C. fraction of purified Kimmridge shale oil. The addition of sodium chloride solution to this mother liquor causes its separation as its mercuric chloride addition product. It was characterized by the methiodide and the mercuric iodide addition compound of the methiodide. Challenger thought that other compounds of this class were present, but did not identify them.

Thiophanes, or cyclic polymethylene sulphides, C_4H_8S (b.p. 118–119° C.), $C_6H_{10}S$ (b.p. 142° C.), and $C_8H_{14}S$ (b.p. 170° C.), together with a number of their methyl and dimethyl derivatives have been recently synthesized by Grischkevitch-Trochimovski [47, 1916].

Teutsch [110, 1934] has recently extracted two isomeric compounds, $C_8H_{14}S$, from the acid sludge from Panuco oil. One of these seems to be identical with one of Mabery's thiophanes. He also found $C_8H_{14}S$ and $C_6H_{10}S$. Mc-Kittrick [76, 1929] seems to have obtained the same $C_8H_{14}S$.

As described in the last section, Thierry [113, 1925] found tetrahydrothiophen, C_4H_8S , and pentamethylene sulphide, $C_5H_{10}S$, along with alkyl sulphides in the oil from the sludge acid from Persian petroleum. The one was identified by its methiodide and mercuric iodide and the other by its sulphone melting at 98° C.

Thiophens

The identification of thiophen and its homologues in benzene, toluene, &c., goes back to Victor Meyer. In more recent times thiophens have been found in many oils.

Ichthyol, a high sulphur oil distilled from fossilized fish remains and the basis of a pharmaceutical preparation, has been the most thoroughly investigated. Scheibler [88, 1915; 89, 1916; 90, 1919; 91, 1920] began with 500 g. of the crude oil from southern France and purified it by treatment with sodium or soda-lime, washing with acid, reaction with methyl magnesium chloride, and distillation over sodium which left 225 g. This was fractionated into 15 cuts, boiling at from 54 to 240° C. at 16 mm. All the fractions gave positive reactions with thiophen reagents. The lowest boiling had the highest sulphur content. Certain of these were refractionated and one was selected boiling at 170–80° C. at 360 mm. which is about the boiling-point of propyl-thiophen. As its sulphur content was about half that of pure propyl-thiophen it was assumed to be a 50:50 mixture of propyl-thiophen and hydrocarbons and was acetylated by acetyl chloride with aluminium chloride in petroleum ether. An acetyl derivative boiling at 118–127° C. at 14 mm. was obtained. By twice reacylating the low fractions, two more acetyl derivatives were separated, the one boiling at 120–135° C. at 14 mm. and the other at 120–140° C. at the same pressure [105, 1928]. From the first of these a semi-carbazone was isolated which gave analytical figures for a derivative of propyl-thiophen, or for a methyl-ethyl- or a trimethyl-thiophen. Bromination, iodination, &c., were carried out, but did not lead to identifications.

Scheibler and Rettig [93, 1926] fractionated oils from Achensee and Seefeld and identified 2-*n*-butyl, 3-*n*-propyl, and 2-isopropyl-thiophens by making the phenyl-hydrazones from the acetylated fractions. They found other alkyl thiophens, but could not prove their structures. As a basis for their identification they synthesized a number of alkyl-thiophens [92, 1926; 94, 1920].

In a study of low-temperature tar, Weissgerber [119, 1921; 120, 1924; 123, 1923] found tetramethyl-thiophen. This could not be identified directly as it cannot be mercurated or acetylated. Both of these reactions depend on the presence of a $-\text{CH}=\text{}$ group next to the sulphur atom. For the same reason it cannot be sulphonated, but is soluble in 90% or even 80% sulphuric acid from which it separates unchanged on dilution with water. The identification was made indirectly but quite satisfactorily by an ingenious procedure [121, 1928]. The oil that had been separated by repeated solution in sulphuric acid representing 0.76% of the original oil boiled at 190–200° C. and had

the high density of 0.950. It was passed through a tinned iron tube at 650–675° C. The product was fractionated and thiophen, α -methyl-thiophen, 2,3-dimethyl-thiophen, and a trimethyl-thiophen were identified. These demethylation products could not have come from anything other than the tetramethyl derivative.

Thionaphthen, the analogue of naphthalene, a fusion of a benzene and a thiophen ring, and diphenylene sulphide, the analogue of anthracene in which the middle ring is thiophen, were found in coal tar and lignite tar respectively by Boes [5, 1902]. Both of these were found in coal tar by Weissgerber and Kruber [119, 1921; 122, 1920]. Thionaphthen cannot be separated from naphthalene by distillation. It is more soluble and melts lower than naphthalene and is more readily sulphonated and mercurated. The crude naphthalene was partially sulphonated and the sulphonic acid decomposed by heating with dilute acid. This gave thionaphthen containing some naphthalene. This product was converted to the mercuric acetate compound from which pure thionaphthen was obtained. Thionaphthen has been identified in crude naphthalene by oxidation with hydrogen peroxide in acetic acid. This gives the sulphone. Weissgerber and Moehrl [123, 1923] found two isomeric methyl-thionaphthens in crude methyl-naphthalene.

In 1901 Kraemer and Weissgerber [61] found diphenylene sulphide in crude fluorene and later Kruber [62, 1920] identified it in crude phenanthrene by oxidation to the sulphone.

Dodonov and Soschestwenskaja [27, 1926] found thiophen and its homologues in Russian bituminous shale oils. Thiophen was identified as its tetrabrom and mercury acetate derivatives and 2-methyl- and 2,3-dimethyl-thiophens as their mercuric chloride derivatives and as the semi-carbazides of their acetyl derivatives.

Pfaff and Kreutzer [82, 1923] studied the lower fraction 60–100° C. from low-temperature tar which was carefully refractionated in a laboratory column. The toluene fraction 109–115° C. and the xylene fraction 135–141° C. had much higher densities than the others and were also comparatively high in sulphur. The toluene fraction, containing 4.4% of sulphur, was acetylated, using phosphoric anhydride as condensing agent. The acetylated product, 1-methyl-5-acetyl-thiophen boiled at 224–227° C., and was characterized by its phenylhydrazone, m.p. 127°, and oxime, m.p. 125°. Low-temperature tar has been investigated also by Morgan, Pratt, and Ross [72, 1929] and by Morgan and Soule [73, 1923].

Extensive and fruitful investigations have been carried on by Challenger, with the assistance of Jinks, Haslam, Bramhall, Walkden, and Wilkinson [13, 1926; 14, 1926; 15, 1926; 16, 1929; 17, 1929; 19, 1926; 20, 1925] on Kimeridge shale oil. Much hydrogen sulphide was evolved in distillation at atmospheric pressure, so the oil was steam distilled, 30% of it going over in this way. This oil was freed from amines, phenols, and traces of ketones by appropriate reagents. Up to 180° C. the purified oil was fractionated at atmospheric pressure and above that at 27 mm. The following fractions were studied (1) 75–93° C., (2) 109–117°, (3) 117–126°, (4) 134–138°, and (5) 158–167° at atmospheric pressure, and (6) 105–115° and (7) 115–140° at 27 mm. Thiophen was identified in fraction (1) by its mercuric-chloride m.p. 180–181° C. From fraction (2) 25% of 2-methyl-thiophen was separated by mercuration with mercuric acetate. It was set free by treatment of the mercury compound with acid and thoroughly identified by its

constants and derivatives. Similarly, 2-ethyl-thiophen and 2,3-dimethyl-thiophen were identified in fraction (4). Their mercuri-chlorides were separated by fractional crystallization and characterized by conversion into the corresponding thio-cyanates. Both of these thiophens were found by Steinkopf [107, 1922] in the tar from the reaction of acetylene with pyrites, and by Dodonov and Soschestwenskaja [27, 1926] in a shale oil.

From fraction (6) thiophanthen was separated as the picrate from which it was set free. It was steam distilled, mercurated, and recovered from the mercury compound, after which it was again distilled and identified as the sulphone, m.p. 143°C. The thiophanthen recovered accounted for but a small part of the 6% of sulphur in this fraction, but no amount of effort could get any light on the nature of the other sulphur compounds that must have been present in large amount.

From the naphtha obtained by cracking Midway (Cal.) crude, by a combination of extraction and fractionation, McKittrick [76, 1929] separated the mercuric chloride complexes of thiophen, its 2-methyl, 3-methyl, 2,3-dimethyl, 3,4-dimethyl, 2-ethyl, and perhaps 3-ethyl derivatives.

Stadnikow and Miss Weizmann [106, 1927] fractionated Russian shale oil and acetylated the fractions with acetyl chloride in the presence of stannic chloride, and prepared semi-carbazones and *p*-nitrophenylhydrazones from the acetyl derivatives. These derivatives indicated a dimethyl or an ethyl and a propyl derivative. Stadnikow and co-workers [105, 1928; 106, 1927] found stannic chloride useful in such acetylations.

Nomekin and Sosnina [77, 1934] have recently proved that the sulphur compounds in the kerosine fraction from Perm crude are chiefly thiophens. Teutsch [110, 1934] has recently identified thiophen and its 2-methyl derivative in fractions of Panuco oil.

Bibliography

The best summary of the work that has been done on the sulphur compounds in mineral oils with the most complete bibliography is found in Challenger's papers [13, 1926; 14, 1926; 16, 1929]. An excellent summary with many references was written by Waters [117, 1920]. A literature survey was made by Borgstrom and Reid [6, 1927].

REFERENCES

- AHRENS, FELIX. C. I. 510 (1906).
- BENNETT, H. T., STORY, LE R. G., and CLARK, I. A. *Oil and Gas J.* 25, no. 47, 138 (1927).
- BIRCHI, S. F., and NORRIS, W. S. G. P. *J.C.S.* 127, 898-907 (1925).
- . *J.C.S.* 127, 1934-44 (1925).
- BOES. *Apotheker Zeit.* 17, 638 (1902).
- BORGSTROM, P., and REID, E. EMMET. *Oil and Gas J.* 26, no. 4, 352-3 (1927).
- V. BRAUN, J. *Z. angew. Chem.* 44, 661-4 (1931).
- . *Petr. Z.* 27, 673-7 (1931).
- . *Petr. Z.* 28, no. 50, 1-6 (1932).
- BROOKS, B. T., and HUMPHREY, I. W. *Ind. Eng. Chem.* 9, 746-8 (1917).
- BROUN, A. S. *J. Ap. Chem.* (U.S.S.R.), 6, 262-5 (1933).
- CADMAN, W. H. *J.I.P.T.* 11, 487 (1925).
- CHALLENGER, F. *Ind. Chem.* 2, 445 (1926).
- . *J.I.P.T.* 12, 106-24 (1926).
- . *Brenn.-Chem.* 7, 373 (1926).
- . *Chem. and Ind.* 7, 622-6 (1929).
- . *Brenn.-Chem.* 10, 277-9 (1929).
- CHALLENGER, F., and HARRISON, J. B. *J.I.P.T.* 21, 135-54, 169-71 (1935).
- CHALLENGER, F., HASLAM, J., BRAMHALL, R. J., and WALKDEN. *J.I.P.T.* 12, 106-34 (1926).
- CHALLENGER, F., JINKS, J. R. A., and HASLAM, J. *J.C.S.* 127, 162-6 (1925).
- CHARITSCHOFF, K. W. *J.S.C.I.* 18, 907 (1899).
- COATES, C. E., and TMS, B. V. *Ind. Eng. Chem.* 14, 219 (1922).
- COONEY, HENRY. *Refiner.* 7, no. 9, 92, 96 (1928).
- COPPADORO, ANGELO. *Glor. chim. ind. applicata*, 3, 3-9 (1921).
- CRAVEN, J. B., and DUNKLEY, W. A. *Amer. Gas Assoc. Monthly*, 5, 251-4 (1923).
- DAY, D. T. *Amer. Phil. Soc.* 36, 115 (1897).
- DODONOV, J., and SOSCHSTWENSKAJA, E. *Ber.* 59, 2202-8 (1926).
- DUDENKO, A. *Nef. Khoz.* no. 6, 42-4 (1931).
- DUNLAP, H. L. *Chem. and Met. Eng.* 24, 298 (1927).
- DUNSTAN, A. E., and BROOKS, B. T. *Ind. Eng. Chem.* 14, 1112-15 (1922).
- DUNSTAN, A. E., THOLE, F. B., and REMFERY, F. G. P. *J.S.C.I.* 43, 179-88 (1924).
- EDELEANU, L., and FILITI, G. A. *Bull. soc. chim.* (3), 23, 384 (1900).
- EGLOFF, GUSTAV, and MORRELL, J. C. *Chem. and Met. Eng.* 28, 633-5 (1923).
- ELLES, F. M., JR., and REID, E. EMMET. *J.A.C.S.* 54, 1674 (1932).
- FERBER, ERWIN. *Z. angew. Chem.* 41, 680-2 (1928).
- FRANKS, A. J. *Chem. and Met. Eng.* 25, 49-53 (1921).
37. FRIEDMANN, W. *Ber.* 49, 50-3 (1916).
38. FRIEDMANN, W. *Ber.* 49, 683-91 (1916).
39. ——. *Ber.* 49, 1344-52 (1916).
40. ——. *Ber.* 49, 1352-5 (1916).
41. ——. *Ber.* 49, 1551-4 (1916).
42. *Erdöl u. Teer*, 6, 285-6, 301-3, 342-4, 359-63 (1930).
43. FÜRTH, A., and JARNICK, M. *Z. angew. Chem.* 38, 166-73 (1925).
44. GLASS, H. B., and REID, E. EMMET. *J.A.C.S.* 51, 3428-30 (1929).
45. GOOKHMANN, L., and KAMINER, V. *Nef. Khoz.* no. 5, 63-7 (1927).
46. GREVELLE, H. L. *J.S.C.I.* 2, 488-92 (1883).
47. GRISCHKEVITSCH-TROCHIMOVSKI, E. *J. Russ. Ph. Ch.* 48, 901, 928, 944, 951, 959 (1916).
48. GUSLIN, M. A. *Petr. Rev.* 28, 486 (1913).
49. GURWITSCH, L. *Z. angew. Chem.* 26, 377 (1913).
50. HACKFORD, J. C. *J.I.P.T.* 12, 136 (1926).
51. HAGER. *Bull. soc. chim.* (2), 7, 527 (1867).
52. HARDING, E. P., and THORNDARSON, WM. *Ind. Eng. Chem.* 18, 731-3 (1926).
53. HELLSING, GUSTAV. *Arkiv. Kemil, Mineral, Geol. Stockholm*, 7, no. 29, 23 (1921).
54. HEUSLER, FR. *Ber.* 28, 493-4 (1895).
55. HEUSLER, FR., and DENNSTEDT, M. *Z. angew. Chem.* 17, 264 (1904).
56. KAW, T. *J.S.C.I. Japan*, 30, 129 (1927).
57. KAUFFMAN, H. L. *Refiner.* 7, no. 8, 73-4 (1928).
58. KAYSER, R. *J. Franklin Inst.* 740, 221 (1895).
59. KEHLSTADT, A. *Ber.* 13, 1345-7 (1880).
60. KRAEMER, G., and SPILKER, A. *Ber.* 35, 1212-33 (1902).
61. KRAEMER, G., and WEISSGERBER, R. *Ber.* 34, 1665 (1901).
62. KRUBER, O. *Ber.* 53, 1566 (1920).
63. MABERY, C. F. *Amer. Chem. J.* 17, 713-48 (1895).
64. ——. *Amer. Chem. J.* 18, 43-79 (1896).
65. MABERY, C. F., and QUAYLE, W. O. *J.S.C.I.* 19, 505-8 (1900).
66. ——. *Amer. Chem. J.* 35, 404-32 (1906).
67. MABERY, C. F., and SMITH, A. W. *Amer. Chem. J.* 13, 232-43 (1891).
68. ——. *Amer. Chem. J.* 16, 83-93 (1894).
69. MAILHE, A. *Chimie et Industrie*, 31, 255-61 (1934).
70. MARINO-CUCCI, F., and TONOLLI, J. *Gaz.* 39, ii, 575 (1910).
71. MEYER, VICTOR, and SANDMEYER, T. *Ber.* 16, 2176 (1883).
72. MORGAN, G. T., PRATT, D. D., and ROSS, J. *J.S.C.I.* 48, 29-34 (1929).
73. MORGAN, G. T., and SOULE, R. P. *Ind. Eng. Chem.* 15, 587 and 696 (1923).
74. MORRELL, J. C., and EGLOFF, G. *Oil and Gas J.* 25, no. 43, 150, 154, and 137 (1928).
75. MUNNELL, ROY. *Refiner.* 5, 23-4 (1926).
76. MCKITTRICK, D. S. *Ind. Eng. Chem.* 21, 985-92 (1929).
77. NAMEKIN, S. S., and SOSNINA, A. S. *J. Ap. Chem.* (U.S.S.R.), 7, 123-6 (1934).

78. OFFE, G. *Gas- und Wasserfach*, **68**, 493-4 (1925).
79. OTTO, R. *Ber.* **13**, 1290-2 (1880).
80. FARRISH, E., and ROWE, F. M. *J.S.C.I.* **45**, 99T (1926).
81. PERKIN, F. M. *J.I.P.T.* **3**, 227-42 (1917).
82. PFAFF, J. K., and KREUTZER, A. *Z. angew. Chem.* **36**, 437 (1923).
83. RAKUSIN, M. A. *Petr. Z.* **18**, 581-2 (1922).
84. RICHARDSON, C. *J.S.C.I.* **17**, 13-32 (1897).
85. RICHARDSON, C., and WALLACE, E. C. *J.S.C.I.* **21**, 316-7 (1902).
86. RUHEMANN, S., and ROSENTHAL, E. *Z. angew. Chem.* **36**, 153-6 (1923).
87. SABATIER. *Catalysis in Organic Chemistry*, tr. by Reid, 334 (Van Nostrand, New York, 1922).
88. SCHEIBLER, H. *Ber.* **48**, 1815-26 (1915).
89. ——— *Ber.* **49**, 2595-600 (1916).
90. ——— *Ber.* **52**, 1903-10 (1919).
91. ——— *Pharm. Monatshefte*, **1**, 182 (1920).
92. SCHEIBLER, H., and RETTIG, F. *Ber.* **59**, 1194-7 (1926).
93. ——— *Ber.* **59**, 1198-1202 (1926).
94. SCHEIBLER, H., and SCHMIDT, M. *Ber.* **54**, 139-54 (1920).
95. SCHMIDT, H. *Petr. Z.* **23**, 646-8 (1927).
96. SCHÜTZ, F. *Ber.* **56**, 162-9 (1923).
97. ——— *Brenn.-Chem.* **4**, 84 (1923).
98. SCHÜTZ, F., BUSCHMANN, W., and WISSEBACH, H. *Ber.* **56**, 1967-75 (1923).
99. SHATWELL, H. G. *J.I.P.T.* **11**, 548-55 (1925).
100. SHEPARD, A. F., HENNE, A. L., and MIDGLEY, T., JR. *J.A.C.S.* **56**, 1355-6 (1934).
101. SIEBENECK, H. *Petr. Z.* **18**, 281-6 (1922).
102. SIEGFRIED, E. *Petr. Z.* **7**, 1320 (1911).
103. SISBINGH, D. W. *Brenn.-Chem.* **6**, 22-5 (1925).
104. SMITH, N. A. C., and STARK, D. D. Bureau Mines, Report of Investigation, no. 2582 (1924).
105. STADNIKOW, G., and RAKOWSKY, W. *Ber.* **61**, 268, 1389 and 2341 (1928).
106. STADNIKOW, G., and WEIZMANN, ANNA. *Brenn.-Chem.* **8**, 343-5 (1927).
107. STEINKOPF, W. *Ann.* **428**, 123 (1922).
108. STEINKOPF, W., and KIRCHHOFF, G. *Ann.* **403**, 1-11 (1914).
109. TERVET, R. *Chem. News*, **45**, 98 (1882).
110. TEUTSCH, I. *Petr. Z.* **30**, no. 20, 1-6 (1934).
111. THIELE, F. C. *Chem. Z.* **25**, 433 (1901).
112. ——— *Chem. Z.* **26**, 896-7 (1902).
113. THIERRY, E. H. *J.C.S.* **127**, 2756-9 (1925).
114. TOMKINSON, MARGARET G. *J.C.S.* **125**, 2264 (1924).
115. WATERMAN, H. J., and HIEMAL, J. H. *J.I.P.T.* **10**, 812-15 (1924).
116. WATERMAN, H. J., PERGUIN, J. N. J., BOGAERS, W. J. M., and GORIS, J. R. H. *Chem. Weekbl.* **22**, 378-80 (1925).
117. WATERS, C. E. Bureau Standards, Tech. Paper, 177 (1920).
118. ——— *Ind. Eng. Chem.* **14**, 725-7 (1922).
119. WEISSGERBER, R. *Brenn.-Chem.* **2**, 1-3 (1921).
120. ——— *Brenn.-Chem.* **5**, 208-14 (1924).
121. ——— *Ber.* **61**, 2111-19 (1928).
122. WEISSGERBER, R., and KRUBER, O. *Ber.* **83**, 1551 (1920).
123. WEISSGERBER, R., and MOEHRLE, E. *Brenn.-Chem.* **4**, 81-4 (1923).
124. WENDT, G. L., and DIGGS, S. H. *Ind. Eng. Chem.* **16**, 1113-15 (1924).
125. WIEZEWICH, P. J., TURNER, L. B., and FROLICH, PER K. *Ind. Eng. Chem.* **25**, 295 (1933).
126. WITTLICH, M. *Acta Comment. Univ. Dorpatensis*, **8**, A viii, 6, 1-12.
127. WOOD, A. E. *Oil and Gas J.* **25**, no. 40, 147, 158 (1927).
128. WOOD, A. E., GREENE, A. R., and PROVINE, R. W. *Ind. Eng. Chem.* **18**, 823-6 (1926).
129. WOOD, A. E., LAWY, A., and FORAGHER, W. F. *Ind. Eng. Chem.* **16**, 1116-20 (1924).
130. WOOD, A. E., SHELLEY, C., and TRUSTY, A. W. *Ind. Eng. Chem.* **17**, 798-802 (1925).
131. ——— *Ind. Eng. Chem.* **18**, 169-71 (1926).
132. ZELINSKY, N. D. *Ber.* **60**, 1793 (1927).

THE SULPHUR COMPOUNDS OF BITUMINOUS OILS

By FREDERICK CHALLENGER, Ph.D., D.Sc., F.I.C.

Professor of Organic Chemistry, University of Leeds

Shale Oil

THE technical literature contains many references to the difficulty experienced in removing the sulphur compounds which are present in the crude Kimmeridge shale oil of Dorset.

The considerable success which was achieved in the removal of sulphur compounds from American petroleum long before their constitution was established is, as is well known, due to two main reasons. First, to the saturated character of most of the hydrocarbons of which American petroleum is composed, and their consequent stability towards sulphuric acid. Second, to the relatively small content of sulphur compounds exhibited by most American oils and by petroleum in general. The sulphur compounds of these oils are soluble in concentrated sulphuric acid probably, as would appear from the work of Mabery [17, 1891; 18, 1894] and of Thierry [31, 1925], without chemical change, since on dilution of the 'acid sludge' they may be recovered.

In the case of shale oils the high percentage of unsaturated hydrocarbons greatly increases the loss during refining, since these compounds are readily soluble in sulphuric acid forming acid sulphuric esters, which are in many cases stable in presence of water and are subsequently lost. It has been shown by Heusler [14, 1895; 15, 1904] that neutral esters of sulphuric acid $\text{SO}_4(\text{OC}_n\text{H}_{2n+1})_2$ may also be formed and under certain conditions may remain in the oil, actually causing an increase in its sulphur content. The elimination of sulphur dioxide, which is occasionally observed on distillation of 'refined' oils, is probably due to the decomposition of these dialkyl sulphates.

Scheibler [26, 1915, 1916, 1919] showed that shale oils from the Tyrol and the south of France contained derivatives of thiophen. Unsaturated hydrocarbons of the indene type were removed by repeated treatment with sodium and sodamide, and traces of ketones were eliminated with magnesium methyl iodide. The resulting purified oil was rich in sulphur, and a suitable fraction on treatment with acetyl chloride and aluminium chloride gave a ketone containing sulphur. Analysis of the semicarbazone indicated the presence of a methyl ketone derived from a propyl-, a methylethyl-, or a trimethyl-thiophen. This established for the first time the presence of thiophen derivatives in shale oil. Later work by Scheibler and Rettig [24, 1926] has demonstrated the occurrence of 2-*n*-butylthiophen, 3-*n*-propylthiophen, and 2-isopropylthiophen in similar shale oils, the compounds being identified as the *p*-nitrophenylhydrazones of the methyl ketones. Pfaff and Kreuzer [22, 1923] detected 2-methylthiophen in lignite tar oil by a similar process. By using phosphorus pentoxide in place of aluminium chloride the Friedel and Crafts reaction was confined to the thiophen derivatives, aromatic hydrocarbons being unaffected. The tetrachlorides of tin and titanium may also replace aluminium chloride with similar results, as has been shown by Stadnikow and others [27, 28, 1927, 1928].

The results obtained in a study of the sulphur compounds of the Kimmeridge shale oil of Dorset may now be summarized (Challenger *et al.* [10, 1926]). The crude oil evolved much hydrogen sulphide during distillation at ordinary pressure. As this indicated possible decomposition, the main bulk was distilled with steam, when about 30% passed over, only small amounts of hydrogen sulphide being noticed. This was possibly in solution in the original oil. Amines, phenols, and traces of ketones were removed from the distillate by successive treatment with dilute hydrochloric acid (1:3), sodium hydroxide (10%), and saturated sodium hydrogen sulphite. This last treatment did not affect the sulphur content. The purified product thus obtained was dried and distilled at atmospheric pressure until the temperature reached 180° C., when the distillate was repeatedly fractionated at atmospheric pressure. The portion boiling above 180° C. was fractionated at 27 mm. No sign of decomposition was observed below 180° C., and even the fractions boiling considerably over 200° C. could be distilled a few times at atmospheric pressure without appreciable decomposition. This behaviour is in marked contrast to that observed when the crude oil, which contained a certain amount of mineral matter, was distilled.

The following fractions were investigated: (1) 75-93° C., (2) 109-117° C., (3) 117-126° C., (4) 134-138° C., (5) 158-167° C., (6) 105-115° C./27 mm., (7) 115-140° C./27mm. Thiophen was detected in fraction (1) and characterized as its mercuri-chloride. Fraction (2) contained about 25% of 2-methylthiophen. On shaking with aqueous mercuric acetate solution this was mercurated and precipitated as a white solid, whilst the unsaturated hydrocarbons were oxidized, giving insoluble mercurous acetate which constituted a large proportion of the deposit. On decomposing the precipitate with hydrochloric acid fairly pure 2-methylthiophen was obtained. This was freed from traces of hydrocarbons by formation of the chloro-mercury derivative, $\text{CH}_3\text{-C}_4\text{H}_4\text{S-HgCl}$ from which it was finally regenerated with acid and identified by its physical constants and by the melting-points of the tribromo-derivative and of the bromo-mercury compound.

By similar methods the presence of 2-ethylthiophen and 2:3-dimethylthiophen was established in fraction (4). The two chloro-mercury compounds were separated and identified as the corresponding thiocyanates. Both these thiophen homologues were detected by Steinkopf [29, 1922] in the tar obtained by the action of acetylene on pyrites. Fraction (5) yielded on similar treatment a chloro-mercury compound which appeared to be derived from a propyl-, a methylethyl-, or a trimethyl-derivative of thiophen. Interesting confirmation of these results was furnished by the somewhat later work of Dodonov and Sochetwenskaja [11, 1926], who detected thiophen, 2-methylthiophen, and 2:3-dimethylthiophen in a Russian shale oil by very similar methods. Traces of benzene and toluene were also present.

Tetrahydrothiophen (tetramethylene sulphide) and probably several similar derivatives are also present in

Kimmeridge shale oil. These compounds can be obtained as insoluble additive compounds with mercuric chloride on addition of common salt to the filtrate obtained after removal of the thiophen derivatives with mercuric acetate.

Tetrahydrothiophen was isolated in this manner from the fraction b.p. 109–117° C., and characterized as mercuric chloride, $C_4H_8S \cdot HgCl_2$, as methiodide $C_4H_8S \cdot CH_3 \cdot I$ and as the mercuric iodide compound of the methiodide. Its objectionable odour and conversion to a sulphone strikingly differentiates it from 2-methylthiophen, which has an odour resembling toluene and forms neither sulphone nor methiodide.

Fraction (6) was warmed with picric acid, giving several deposits of a yellow crystalline picrate which were united and distilled with sodium carbonate in steam, when a solid was obtained having the odour of naphthalene and containing combined sulphur. With aqueous methylalcoholic mercuric acetate (Weissgerber and Krüber [33, 1920]) an insoluble solid containing some mercurous acetate was obtained. Distillation with steam gave an oil which partially solidified at 0° C. and contained thionaphthen, since on oxidation with hydrogen peroxide in glacial acetic acid at 100° C. thionaphthen sulphone was obtained.

The crude thionaphthen was reconverted to the picrate. The product melted at 144° C., whereas thionaphthen picrate has m.p. 149° C. On repeated crystallization from alcohol the melting-point was finally constant at 142.5° C. According to Meyer and Meyer [20, 1918] the melting-point of an equimolecular mixture of the picrates of thionaphthen and of thiophthen is 140–141° C. Such a non-separable mixture was actually obtained by Meyer [20, 1918] from the products of the action of acetylene on hydrogen sulphide.

The peculiar green fluorescence obtained from the picrate or the crude thionaphthen with sulphuric acid suggests the presence of one or both of the isomeric thiophthenes, $C_6H_4S_2$ (Challenger and Harrison [9, 1935]). Moreover, during the fractionation of the picrate an odour was observed which resembled that of thiophthen, but was different from that of thionaphthen. The presence of thiophthen could not, however, be definitely established.

The amount of the fraction b.p. 105–115° C. which combined with picric acid was extremely small. The main bulk, which was inert to this reagent, was shaken with sodium hydroxide and distilled in steam. The sulphur content, about 6%, was found to be almost unaffected. Further research must decide the interesting question as to the mode of combination of the sulphur.

Isolation of Sulphur Compounds. Recent Modifications in Technique.

In Victor Meyer's early researches on thiophen and its homologues these compounds were isolated from crude benzene, toluene, and xylene by repeated fractional sulphonation (Meyer [21, 1888]). Later he developed synthetic methods for these compounds; their extraction from bituminous oils was greatly improved by the use of methods involving mercuration (Steinkopf [29, 1914, 1921, 1922]).

Leclère and Leclère [16, 1932] have examined a sulphurous shale oil from St. Champ. A suitable fraction dissolved in petrol was treated in the cold with 96.5% sulphuric acid for one hour, whereby preferential sulphonation of the thiophen homologues occurred in one operation. Decomposition of the sulphonic acids with boiling water gave a fraction b.p. 150–160° C. containing 25.6% of sulphur.

Propylthiophenes require 25.4%. The authors state, without giving any experimental details or other information, that the mixture contained 1-*n*-propylthiophen, 1-*iso*-propylthiophen, and 2-*iso*-propylthiophen. This method is stated to be much superior to that involving repeated sulphonation.

Ruhemann and Baumbach [23, 1932] have also employed sulphuric acid in the isolation of a thiophen homologue from a lignite oil fraction of b.p. 140–145° C., rich in unsaturated hydrocarbons. Under their conditions sulphonation either does not occur or plays only a small part, and a product $C_{14}H_{22}S$ b.p. 146–150° C. at 14 mm. was isolated. As a result of their experience of the action of sulphuric acid on the unsaturated hydrocarbons of lignite and coal oils (1931, see below) this compound was submitted to slow distillation over 'Frankonit', whereby 2:3-dimethylthiophen ($C_8H_{10}S$) and an unsaturated hydroaromatic compound $C_{14}H_{22}$ were obtained. The occurrence of this thiophen derivative in bituminous oils has already been mentioned. Ruhemann [23a, 1931] had previously shown that the polymers of unsaturated hydrocarbons could be depolymerized by heating with 'Floridin' (fuller's earth).

Two compounds $C_{14}H_{20}$ and $C_{14}H_{18}$ formed during the refining of a lignite oil with sulphuric acid yielded under these conditions the thiophen carboxylic $C_{12}H_{16}$ and a mixture of $C_{12}H_{20}$ and $C_{12}H_{18}$ respectively.

Petroleum

Mabery [17, 1891; 18, 1904, 1906] extracted various fractions of American petroleum with sulphuric acid, establishing the presence of methyl-, ethyl-, and butyl sulphides in the crude oil, the sulphides dissolving unchanged in the acid. From Canadian oil he obtained a large number of compounds of the formula $C_nH_{2n}S$, which he called 'thiophanes'. These resembled the alkyl sulphides in forming sulphones, methiodides, and additive products with mercuric chloride. Their densities, however, were much higher than those of the open-chain alkyl sulphides, they bore no resemblance whatever to the thiophen homologues, and Mabery regarded them as either 'hydrothiophenes with long side-chains, methylene sulphides with numerous or long side-chains, or simple ring methylene sulphides'. It was not proved, however, that the tetrahydrothiophen or thiophane ring was present in any of these compounds, which ranged in boiling-point from 125 to 295° C. The use of the term 'thiophane' was therefore hardly justified.

In view of the extent to which Mabery's work has been quoted, reference may here be made to a critical discussion of his results and the conclusions to be drawn from them (Challenger [7, 1926]).

The work of Thiery [31, 1925] has furnished results very similar to those of Mabery. By addition of water to a sulphuric acid sludge obtained during the refining of Persian petroleum he isolated methyl ethyl sulphide, tetrahydrothiophen, and pentamethylene sulphide. About the same time Birch and Norris [3, 1925] established the presence of ethyl-, isopropyl-, and isoamyl mercaptans in a low-boiling fraction of Persian petroleum. After extraction with sodium hydroxide their partial conversion to the corresponding disulphides was observed. The authors point out that the acidity of mercaptans diminishes rapidly with increase in molecular weight, and consequently the higher mercaptans are not completely removable by soda washing only.

The two last-mentioned compounds, and in addition

2-methyltetrahydrothiophen, have also been isolated by Teutsch [30, 1934] from crude Panuco oil along with two compounds $C_8H_{10}S$ and $C_8H_{12}S$. From the acid sludge obtained on refining Panuco oil two isomeric compounds $C_8H_{10}S$ were separated. These four sulphides were not identified, but it may be noted that they have the composition $C_8H_{10}S$ characteristic of Mabery's 'thiophanes'. The uniformity in type and often in constitution exhibited by the sulphur compounds from different oils is very striking.

Still another investigation along these lines must be recorded. McKittrick [19, 1929], working in the laboratories of the Standard Oil Company of California, has made a prolonged study of the sulphur compounds contained in a naphtha b.p. 30–250° C. obtained by the cracking of a fuel oil from 'California Midway Crude'. In this case a preliminary concentration of the sulphur compounds was effected by repeated extraction of the oil with liquid sulphur dioxide at –20 to –30° C. The united extracts were evaporated and submitted to a series of fractional extractions, first with aniline and then with ethylene glycol diacetate. Systematic fractional distillation of the product, followed by treatment with mercuric chloride and sodium acetate, led to the identification of thiophen, 2- and 3-methylthiophen, 2:3- and 3:4-dimethylthiophen, and 2- and 3-ethylthiophen. The 'acid sludge' obtained by refining a similar cracked naphtha with sulphuric acid was also examined. Dilution with water gave an oil in which the presence of sulphides apparently containing 8 and 11 carbon atoms respectively and analogous in properties with Mabery's 'thiophanes' was detected.

A considerable amount of work has been published during the last 10 years on the changes undergone by the chief classes of sulphur compounds in presence of the common refining agents, as applied more particularly to petroleum.

This work has been admirably summarized by Ellis [12, 1934], and its detailed consideration falls outside the scope of this section. In a few cases, however, the refining agent, especially sulphuric acid, may alter the nature of the sulphur compound without removing it or, as already mentioned (Heuster [14, 1895; 15, 1904]), may actually produce an organic sulphur derivative by its action on an olefine.

A further instance of this is afforded by the work of Birch and Norris [4, 1929], who have shown that, by the action of sulphuric acid on a naphtha containing mercaptans, small quantities of polysulphides may be formed which remain in the oil owing to their insolubility in the acid. The presence of these compounds may be recognized by the corrosive effect of the boiling naphtha on a bright copper strip, whereby copper sulphide is formed. In applying this test free sulphur is first removed by shaking with mercury at the ordinary temperature. The reaction presumably occurs by the partial oxidation of the mercaptans to disulphides by the sulphuric acid. This consequently undergoes some reduction to sulphur dioxide and hydrogen sulphide. Interaction of these gases in sulphuric acid solution gives sulphur which probably combines with some unchanged mercaptan (rather than with the disulphides) to form a polysulphide. It was not found possible to cause free sulphur to combine with a disulphide or sulphide to form a polysulphide, in presence of a hydrocarbon at room temperature.

This view is supported by the observation that a polysulphide is formed when *isobutyl*- or *isoamyl* mercaptan in petroleum solution is shaken at room temperature with

powdered sulphur, or when sulphur dioxide, followed by hydrogen sulphide, is led into the solution. The polysulphide thus produced can be identified by removing excess of sulphur and reducing with zinc dust and acid, thus giving rise to a mercaptan and hydrogen sulphide. This reaction is also given by the 'refined' specimens of naphtha which exhibit the corrosive action on copper.

Finally, diethyl trisulphide was prepared and was found to exhibit the characteristic corrosive action on copper.

Coal and Lignite Oils

Various derivatives containing condensed thiophen nuclei were isolated from these oils by Boes [5, 1902] and by Weissgerber and Krüber [33, 1920]. Boes obtained diphenylene sulphide and thionaphthen from coal tar and lignite tar respectively; both these compounds were obtained by Weissgerber from coal tar. The thionaphthen was freed from some of the naphthalene by preferential sulphonation and subsequent decomposition with acid, giving a mixture still containing naphthalene, from which it was separated as the mercuric acetate compound, thus giving pure thionaphthen on decomposition with acid. Mercuric acetate does not react with naphthalene under the conditions employed. The thionaphthen was also detected in presence of naphthalene by oxidation to the sulphone with hydrogen peroxide in glacial acetic acid, a method which also served for the recognition of diphenylene sulphide in crude phenanthrene.

Weissgerber and Moehrlé [34, 1921] state that two isomeric methylthionaphthenes have been isolated from the crude methylnaphthalenes of coal tar.

Weissgerber [32, 1928] also showed that low-temperature tar contains tetra-substituted derivatives of thiophen of boiling-point about 200° C. His results may briefly be summarized.

The fraction b.p. 187–201° C. was washed with 2% of sulphuric acid to remove coumarones and indenes, and extracted with sulphuric acid (90%) at 15–20° C. The acid, on dilution with water, gave an oil from which ketones and nitriles were next eliminated. Treatment with sulphuric acid then removed some insoluble hydrocarbons. The remainder of the oil could be reprecipitated from the acid by adding water, and represented 0.76% of the original oil. Its density was very high (0.95), its b.p. 190–200° C., its odour somewhat unpleasant, and the sulphur content in different fractions 16–19%. Alkyl sulphates and mercaptans were absent, and the usual tests for sulphides failed. The stability to sulphuric acid pointed to the presence of tetra-substituted thiophen derivatives; oxidizing agents gave sulphuric acid, and no chloro-mercury compound could be obtained, this being further evidence of the absence of nuclear hydrogen atoms.

Weissgerber showed that on passage with hydrogen through a heated tin-lined iron tube, 2:4-dimethylthiophen gave thiophen and methylthiophens. Application of this method of pyroanalysis to the assumed tetramethylthiophen at 650–675° C. gave a mixture in which thiophen, α -methylthiophen, and 2:3-dimethylthiophen were identified.

A compound giving a chloro-mercury derivative, which, from its analysis, appeared to be derived from trimethylthiophen, was also isolated. Tetramethylthiophen could not be obtained by synthesis, but dimethyldiethylthiophen was specially prepared for comparison. It boiled at 214–217° C., had density 0.9573, was soluble without change in

sulphuric acid, and gave sulphuric acid on oxidation. The identification of the stable sulphur compound as tetramethylthiophen appears therefore to be justified.

The Possible Importance of the Isomeric Thiophthenes in Shale Oil.

The occurrence of naphthalene, thiophen, and thionaphthen in coal tar and in Kimmeridge shale oil suggested that thiophthen (I) or (II) might also be an ingredient of bituminous oils. Attempts by Meyer and Meyer [20, 1918] to detect this substance in coal tar and in lignite tar were, however, unsuccessful. Some evidence of the occurrence of thiophthen in Kimmeridge shale oil has already been mentioned. On the other hand, the published information concerning thiophthen and its derivatives was at that time so scanty that success was hardly to be expected until these compounds had been further characterized.

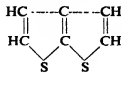
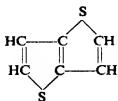

Thiophthen was first prepared by Biedermann and Jacobson [2, 1886], who heated citric or tricarballic acids with phosphorus trisulphide. A tar distilled which, on fractionation, yielded an oil, b.p. 220-230° C. This was purified through its picrate, which on decomposition with alkali gave an oil, b.p. 224-226° C., having the composition $C_8H_6S_2$ and remaining liquid at $-10^\circ C$. The yield before picrate formation was less than 1%.

Capelle [6, 1908] passed acetylene into the vapour of boiling sulphur and absorbed the distillate in carbon disulphide. Removal of the solvent, extraction with ether or alcohol, and fractionation in the presence of sodium hydroxide yielded an oil, b.p. 225° C., which gave a picrate, m.p. 134° C., stated to be identical with that obtained by Biedermann and Jacobson.

The writer and Dr. J. B. Harrison [9, 1935] have investigated both these methods for the preparation of the thiophthen, obtaining results which should facilitate the search for the isomeric thiophthenes in bituminous oils.

Acetylene was passed in a rapid stream into the vapour of boiling sulphur. The crude distillate, freed from carbon disulphide and thiophen, was distilled in steam and that portion of b.p. 115-120° C. at 20 mm. converted to the picrate of m.p. 139-141° C. and decomposed with sodium carbonate giving a colourless oil, b.p. 221-222° C. (102-104° C. at 15 mm.). Its analysis agreed with that of slightly impure thiophthen. On standing it gradually deposited a substance which, on crystallization from light petroleum, formed a snow-white solid m.p. 56° C. (I), had a composition and molecular weight corresponding to $C_8H_6S_2$ and gave a picrate $C_8H_6S_2 \cdot C_6H_5(NO_2)_2OH$ of constant m.p. 145° C. No mention of this solid thiophthen is made by the earlier workers who employed the acetylene method for the preparation of thiophthen. It may here be mentioned, however, that Anschütz and Rhodius [1, 1914] drew attention to the theoretical existence of two isomeric thiophthenes.

By a prolonged series of operations, involving formation of picrate, stypnate, and chloro-mercury derivative, it was shown that the liquid portion contained an isomeric

thiophthen of m.p. 6.25-6.5° C. It was not possible, in spite of the preparation of a large number of derivatives, to determine with certainty whether this low-melting thiophthen was identical with that of Biedermann and Jacobson which was also prepared for comparison, and when purified found to melt at 5.75-6° C. (II).

Ring Fission of Thionaphthen and Thiophthen.

Reference may here be made to two very interesting reactions of thionaphthen which appear to be applicable to its homologues.

According to Frické and Spilker [13, 1925] thionaphthen is reduced by sodium and alcohol to its dihydro-derivative and then to *o*-ethylthiophenol.

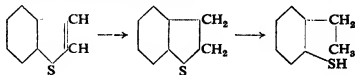

On removing unchanged oil and acidifying the alkaline residue, this mercaptan or one of its homologues should be liberated, and capable of easy identification.

The second method depends on the observation of Weissgerber and Seidler [35, 1927] that thionaphthen on heating with potassium hydroxide in an autoclave at 300° C. is converted to *o*-thiocresol, which can easily be obtained in quantity on acidifying the cold, fused mass.

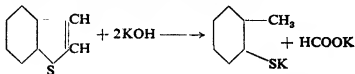

The writer and Harrison [9, 1935] have applied Frické and Spilker's method to the reduction of the solid isomer of thiophthen (see above) and find that a mercaptan is produced and the second thiophen nucleus ruptured. Analysis of the mercury derivative showed it to be derived from an ethylthienyl mercaptan. The reaction proceeds therefore in an exactly analogous manner to the reduction of thionaphthen.



The methods just indicated should prove extremely valuable in the examination of mineral oils containing sulphur, and Weissgerber suggests that the alkali fusion might be useful in desulphurization on the large scale.

No mercaptan could be obtained, however, on heating the fractions of Kimmeridge shale oil (Dorset) of b.p. 90-100° C. at 27 mm. and of b.p. 115-130° C. at 27 mm. with sodium and alcohol or with potassium hydroxide under these conditions, and it would appear that the sulphur compounds in these fractions of Kimmeridge shale oil are not in the main derived from thiophthen. Some unpublished observations of the writer and Wilkinson suggest that tetrasubstituted thiophthenes may be present, as has already been demonstrated by Weissgerber [32, 1928] in the case of low-temperature tar.

The elucidation of the nature of the sulphur compounds

in the higher-boiling fractions of bituminous oils remains a problem of some urgency, since, apart from thionaphthen, its methyl derivatives and diphenylene sulphide, no sulphur ingredient has been identified in these fractions.

This account of the sulphur compounds of bituminous oils is in part based upon various papers by the writer published in the journals of the Institution of Petroleum

Technologists (1926, 1935) and the Society of Chemical Industry (1929). These contain extensive bibliographies.

Useful summaries dealing with the various sulphur compounds in mineral and bituminous oils have recently been published by G. Free [12a, 1935, 1936]. Their utilization has been discussed by Wieszewich *et al.* [36, 1933] and by Schmeling [26a, 1936].

REFERENCES

1. ANSCHÜTZ, R., and RHODIUS, E. *Ber.* **47**, 2733 (1914).
2. BIEDERMANN, A., and JACOBSON, P. *Ber.* **19**, 2444 (1886).
3. BIRCH, S. F., and NORRIS, W. S. *J.C.S.* **127**, 898 (1925); **127**, 1934 (1925).
4. ——— *Ind. Eng. Chem.* **21**, 1087 (1929).
5. BOES, J. *Apotheker-Zig.* **17**, 565 (1902); **17**, 638 (1902).
6. CAPELLE, G. *Bull. Soc. Chim.* **3**, 151 (1908).
7. CHALLENGER, F. *J.I.P.T.* (Discussion), **12**, 137 (1926).
8. ——— *J.S.C.I.* **48** (*Chem. and Ind.*), 622 (1929).
9. CHALLENGER, F., and HARRISON, J. B. *J.I.P.T.* **21**, 135 (1935).
10. CHALLENGER, F., HASLAM, J., BRAMHALL, R. J., and WALKDEN, J. *I.P.T.* **12**, 106 (1926).
11. DODONOW, J., and SOCHETWENSKAJA, E. *Ber.* **59**, 2202 (1926).
12. ELLIS, C. *The Chemistry of Petroleum Derivatives*. The Chemical Catalog Co. 1934.
- 12a. FREE, G. *Chem. Zig.* **59**, 975 (1935); **60**, 547 (1936); *Oel u. Kohle*, **12**, 311 (1936); *Brenn.-Chem.* **17**, 45 (1936).
13. FRICKE, G., and SPILKER, R. *Ber.* **58**, 24 (1925); **58**, 1589 (1925).
14. HEUSLER, F. *Ber.* **28**, 491, 498 (1895).
15. HEUSLER, F., and DENNSTEDT, M. *Z. angew. Chem.* **17**, 264 (1904).
16. LECLÈRE and LECLÈRE. *Compt. rend.* **194**, 286 (1932).
17. MABERY, C. F. *Amer. Chem. J.* **13**, 233 (1891); **16**, 92 (1894).
18. ——— *J.A.C.S.* **28**, 419 (1906); **28**, 426 (1906).
19. MCKITTRICK, D. S. *Ind. Eng. Chem.* **21**, 585 (1929).
20. MEYER, R. J., and MEYER, W. *Ber.* **51**, 1575 (1918).
21. MEYER, V. *Die Thiophen Gruppe*. Vieweg and Sohn: Braunschweig (1888).
22. PFAFF, J. K., and KREUTZER, A. *Z. angew. Chem.* **36**, 437 (1923).
23. RUHEMANN, S., and BAUMBACH, H. *Braunkohle*, **31**, 549 (1932); **31**, 565 (1932).
- 23a. RUHEMANN, S. *Z. angew. Chem.* **44**, 75 (1931).
24. SCHEIBLER, H., and RETTIG, F. *Ber.* **59**, 1194, 1198 (1926).
25. ——— *Z. angew. Chem.* **39**, 1397 (1926).
26. SCHEIBLER, H. *Ber.* **48**, 1815 (1915); **49**, 2595 (1916); **52**, 1903 (1919).
- 26a. SCHMELING. *Oel u. Kohle*, **12**, 837 (1936).
27. STADNIKOW, G. L. *et al. Ber.* **61**, 268, 1389, 1996, 2341 (1928).
28. STADNIKOW, G. L., and WEIZMAN, A. E. *Brenn.-Chem.* **8**, 343 (1927).
29. STEINKOFF, W. *Annalen der Chemie*, **428**, 123 (1922); **403**, 1 (1914); **424**, 1 (1921); **430**, 41 (1922).
30. TEUTSCH, *Petr. Z.* **30**, (20), 1 (1934).
31. THIERRY, J. *J.C.S.* **127**, 2756 (1925).
32. WEISSGERBER, R. *Ber.* **61**, 2111 (1928).
33. WEISSGERBER, R., and KRÜBER, O. *Ber.* **53**, 1552 (1920); **53**, 1566 (1920).
34. WEISSGERBER, R., and MOEHLE. *Brenn.-Chem.* **2**, 1 (1921).
35. WEISSGERBER, R., and SEIDLER. *Ber.* **60**, 2089 (1927).
36. WIEZEWICH, P. J., *et al. Ind. Eng. Chem.* **25**, 295 (1933).

NITROGEN COMPOUNDS

THE NITROGEN BASES OF PETROLEUM DISTILLATES

By J. R. BAILEY, Ph.D.

Professor of Organic Chemistry, University of Texas

COAL-TAR distillates have long been known as sources of aromatic nitrogen bases. Most of these aromatic bases are familiar and rather easily separated. Petroleum distillates usually contain such very small proportions of nitrogen bases that they are commonly ignored in the refining of petroleum oils, and investigation of these organic bases has been relatively neglected. In the case of certain petroleum, however, the content of nitrogen bases in the distillates, while not large, is sufficiently great to have attracted investigation. Recent work has shown that these products represent a complex mixture of several types of cyclic nitrogen bases.

In Pennsylvania petroleum the nitrogen content is reported to be about 0.008% [3, 1891]. Of American petroleum certain of the California oils contain the highest nitrogen content, the maximum being 0.82% [2, 1928].

Nothing is known of the structure of the nitrogen compounds in crude, undistilled petroleum. The bases which have been studied are encountered in appreciable quantity in the distillates. Even in the distillates of the California oils, studied in the writer's laboratory, most of the nitrogen exists in compounds which are inert to dilute mineral acids [2, 1928; 2, 1930]. The bases are evidently decomposition products of more complex nitrogen compounds in the original crude oils.

Nitrogen bases derived from California oils were investigated by Mabery and Wesson [17, 1920] without any definite results. They believed that these bases consist principally of alkylated quinolines or iso-quinolines.

The bases investigated in the writer's laboratory were extracted from the kerosine distillate from the crude of the McKittrick field in the San Joaquin Valley. The kerosine distillate contained 0.64% nitrogen. The name kero bases indicates this origin. The volume-temperature results obtained on distilling these bases is given in Fig. 1.

An exhaustive examination of these bases was undertaken in the University of Texas Laboratory in 1926 as Research Project no. 20 of the American Petroleum Institute. This work has revealed that bases obtained from liquid sulphur dioxide extract of California kerosine consist in preponderant amount of non-aromatic types, not previously obtained from any other natural source and not made by synthesis. The presence of hydro-aromatic bases in coal-tar distillates has been suspected [6, 1930; 7, 1903]. The quinoline homologues 2,3-dimethyl, 2,4-dimethyl, and 2,8-dimethyl [4, 1933; 14, 1933]; also 2,3,8-trimethyl and 2,4,8-trimethyl quinolines have also been found in the kero-base mixture [11, 1930; 19, 1934]. Search for the coal-tar bases, quinoline, iso-quinoline, quinaldine, and lepidine, was successful.

Non-aromatic bases apparently occur in all petroleum distillates beginning with kerosine, below which, it may be expected, only pyridine and its homologues will be encountered.

Whether in all crudes there is only a negligible amount

of preformed organic bases and whether, in all fractions of distillates of crudes from different pools, the same base will be encountered remain to be determined. In any event, and in line with the effect of temperature on the structure of hydrocarbons produced in the distillation of coal, it is certain that the bases in cracked petroleum distillates are markedly different from those in straight-run distillates.

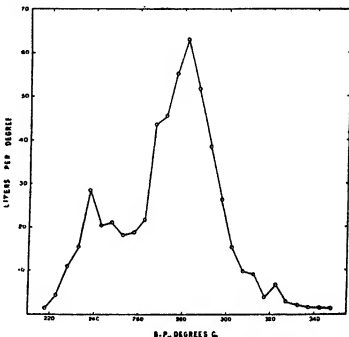

FIG. 1. Volume distribution of kero bases.

Mabery and Wesson carried out the first investigations of bases from California petroleum, which 'were separated from California distillates by Peckham and Solathe' [16, 1900; 17, 1920]. In view of the fact that no individual base was isolated, it is not surprising that the structural conclusions which were the outgrowth of their research are no longer tenable.

Exhaustive fractional distillation with the use of an efficient reflux column is a prerequisite in the isolation of petroleum bases, and, at times, when followed by fractional acid extraction, a separation of individual components has resulted [1, 1933; 14, 1933; 21, 1931].

So-called 'Cumulative Extraction' [19, 1933] has proved very efficient in segregation of either crude bases or distillation fractions into aromatic and non-aromatic types, and sometimes produces a partial separation of the latter into groups. This process depends on a wide difference in the distribution ratio of the hydrocarbons of the two main families of bases between water and chloroform or ethylene chloride, whereby the aromatics concentrate in the aqueous and the non-aromatics in the chloroform layer. A solution of the bases in dilute hydrochloric acid is extracted with the organic solvent, and then the aqueous layer

is washed with the solvent and the solvent layer with water until refractive index control on the regained bases indicates a satisfactory separation. The aromatic bases can be processed further through conversion to acid sulphates in alcohol or acetone solution. Cumulative extraction, as applied to the 275° C. fraction of kero bases, resulted in the isolation of the following components as picrates or hydrochlorides: 2,3,8-trimethylquinoline and 2,4,8-trimethyl quinoline, 2,3-dimethylquinoline, a $C_{14}H_{18}N$ non-aromatic base, and an unidentified product (m.p. of picrate 174° C.).

The 2,3-dimethylquinoline, along with 2,4-dimethylquinoline, had been previously separated from the 265–7° C. fraction by the use of sulphur dioxide [4, 1933]. With the exception of 2,3,8-trimethylquinoline, all aromatic bases referred to above were previously known to synthesis, but none had been obtained from a natural source.

In an indirect method of micro-distillation, termed 'Amplified Distillation', the bases are mixed with a relatively large volume of petroleum hydrocarbon oil [5, 1936]. The hydrocarbon mixture is prepared by blending equal volumes of 5° C. fractions in order to obtain an evenly boiling mixture, ranging from 30° C. below to 5° C. above that of the base fractions. The separate distillates are acid extracted and the regained bases processed in the usual way. Apart from offering the most practical method of micro-distillation, this method has the advantage over straight distillation of reduced cracking and enhanced efficiency. Obviously, the same principle can be applied in other directions.

The wide difference in the reaction velocity of alkyl halides with kero bases can be applied as a general method of resolution. It is well known that the destructive distillation of quaternary halides of aromatic bases can cause migration of N-alkyls to the ring nucleus [15, 1883; 15, 1884], a complication that has not been observed in the case of the same derivatives of non-aromatic kero bases. The process is of importance only in non-aromatic series.

The non-aromatic kero bases are apparently cyclic tertiary amines, and the isolation of individual products, even from exhaustively distilled fractions, presents a very difficult problem; for example, in the 275° C. fraction the non-aromatic bases, so far unaccounted for, constitute at least 60% of the total volume. The complexity of the mixtures causes a quite uniform solubility of like salts of the component bases in all solvents, with the result that a complete segregation through recrystallization is impractical.

After fractional separation of non-aromatic bases through their methiodides, even where these derivatives are not obtained in crystalline form, destructive distillation gives a satisfactory recovery of bases, and at times individual products are in such concentration that recrystallization of their picrates effects final purification.

Two non-aromatic kero bases have been reported. One [1, 1933] has the composition $C_{14}H_{18}N$, with m.p. 24–5° C.; b.p. 225–6° C. (750 mm.); *d* 20/4 0.8700; *n* 25/D 1.4833. The other [13, 1934; 21, 1933] has the composition $C_{14}H_{18}N$, with m.p. 23–24° C.; b.p. 278–2° C. (746 mm.); *d* 20/4 0.9391; *n* 20/D 1.5129. Both substances resist hydrogenation and dehydrogenation, and prolonged heating with alkaline solution of permanganate has no oxidizing effect. In dilute sulphuric acid solution they reduce permanganate readily.

Due to the small amount of the 13-carbon base originally available, proof of structure was impractical. However,

the following deductions seem warranted. The empirical formulae $C_{14}H_{18}N$ and $C_{14}H_{18}N$ show that the two compounds belong to different homologous series, $C_nH_{2n-2}N$, respectively. It is highly probable from their molecular weights and physical constants, along with other considerations, that the 13-carbon molecule contains a binuclear and the 16-carbon molecule a trinuclear ring system. In order to account for the saturated condition of both molecules a double bridging must be assumed in each. Naphthenic, or cyclopentane structure, as assumed in the following provisional structural interpretation of the two bases, seems probable:

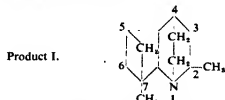

Octahydro-2,7-dimethyl-5,7-methano-1,4-ethanopyrindine.

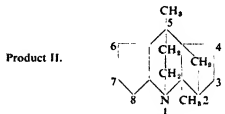

Decahydro-1a,5-dimethyl-2,4a-methano-1,5-ethanopyrindacine.

In explanation through steric hindrance of the non-formation of a methiodide by the $C_{14}H_{18}N$ base, its two methyls are assigned positions 2 and 7 in formula I. The assumption of a methylene instead of an ethylene bridge in the piperidine nuclei would require an addition methyl in each formula.

A naphthenic base, 5,6-dihydropyrindine,



has been discovered in shale oil [9, 1929] and synthesis has confirmed the structure originally proposed [22, 1931]. The conversion of product II on nitric acid oxidation to berberonic acid, pyridine-2,4,5-tricarboxylic acid, proves that the nitrogen is in a 6-membered ring [21, 1931].

Product II is an isolated example of a non-aromatic base with aromatic character, as is evidenced by two reactive methyls. It condenses with benzaldehyde to form a dibenzal derivative [1, 1933] and yields with phthalic anhydride a true phthalone. Doja [8, 1932] states: 'A methyl group in a quinoline is known to lose its power of condensation with ketones or aldehydes when the ring is partially or totally reduced.'

In parallel with a similar reactivity of the two alkyls in 2,4-dimethylquinoline, the reaction product of the pyridacine with formaldehyde is converted through nitric acid oxidation to a dicarboxylic acid, $C_{14}H_{18}N(COOH)_2$, which on decarboxylation yields a monocarboxylic acid, $C_{14}H_{18}NCOOH$ and finally $C_{14}H_{18}N$, base. Therefore, two carbons in the $C_{14}H_{18}N$ compound are in the form of methyls [13, 1934].

Formula I, although highly speculative, suggests that the *neo-carbon* system [cf. 23, 1933],

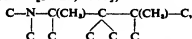

induces in the two methyls the same reactivity which characterizes the alkyls in the conjugate double-bond system,

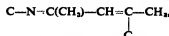

of 2,4-dimethylquinoline; at any rate, an unusual structural feature of the saturated base imparts aromatic character.

In an attempt to explain the origin of the non-aromatic bases in petroleum distillates, which in turn might have an important bearing on the origin of petroleum itself, a study of protein pyrolysis was instituted in the Texas Laboratory. If petroleum is of vegetable or animal origin, or both, then it is highly probable that not only protein, but in addition fats and carbohydrates were involved in a metamorphosis which resulted in the formation of complex non-basic nitrogen compounds, and the latter in petroleum refining undergo pyrolysis, giving a small yield of organic bases. It has been found that pure proteins on pyrolysis yield comparatively few bases [10, 1924; 20, 1919].

In order to determine whether a material containing protein, fats, and carbohydrates would, on admixture with nitrogen-free lubricating oil, yield aromatic, and more especially non-aromatic, bases, the Union Oil Company of California subjected to destructive distillation 23 tons of cotton-seed meal, with 4,000 gal. of hydrocarbon oil as a liquid medium. The complexity of the various fractions of organic bases obtained is comparable to that of kero-base fractions. The meal bases, however, differ from those formed in the distillation of coal, shale, bones, or petroleum in several respects: in storage they have a pronounced tendency to decompose or polymerize with excessive tar formation; they are in preponderant amount petroleum ether insoluble; diazines are present in relatively large quantities. In so far as their investigation has progressed, there is no reason to suspect among the meal bases non-aromatic types similar to non-aromatic kero bases. The only kero base thus far isolated is 2,3,8-trimethylquinoline. [18, 1936]. This investigation presents for future study a practically unexplored field in protein pyrolysis.

It is noteworthy that all the keroquinolines reported are methylated at position 2, the other positions of substitution being 3, 4, and 8. All of them form phthalones of the same shade of yellow as quinoline yellow, the valuable dye derived from coal-tar quinaldine, or 2-methylquinoline; accordingly, they may find industrial use as dye intermediates.

As concerns the non-aromatic kero bases, which are undoubtedly of various types and of great number, with most, if not all, of them unknown to synthesis, a comprehensive study of their structure and properties must precede an evaluation of commercial applications. There is a chance that pharmacological research may reveal here a source of new medicinals of therapeutical potency.

If structural elucidation of non-aromatic petroleum bases leads to a positive confirmation of the existence of naphthenic types, their molecular arrangement may be in some cases similar to that in naphthenes and naphthenic acids. Corresponding to many cyclic nitrogen compounds, known hydrocarbons can be derived by replacement of N or NH by CH or CH₂, respectively. It is not entirely improbable that the same analogy in some cases holds for petroleum bases and hydrocarbons of cyclopentane structure.

The isolation and proof of structure of individual hydrocarbons outside the aromatic series present experimental difficulties far greater than applies to nitrogen bases. The proposed bridged structure of the C₁₄H₂₁N and C₁₆H₂₃N compounds suggests that, were petroleum naphthenes encountered of the composition C₁₄H₂₁N and C₁₇H₂₅N, i.e. of the respective series C_nH_{2n-3} and C_nH_{2n-5}, complexes analogous to those in nitrogen compounds might be suspected.

APPENDIX*

Recently it has been found that the naphthenic base C₁₄H₂₁N, previously regarded as completely saturated, can be reduced over a catalyst of Rainey nickel at 250° C. and 200 atm. pressure to yield a compound corresponding to the formula C₁₄H₂₁N (1). The new product, which was identified as a secondary amine through preparation of the methyl, benzoyl, and nitroso derivatives, was dehydrogenated [9] with silver acetate according to the method of Tafel to yield the original base [13, 1892].

The identification through high-pressure hydrogenation of the pyridine nucleus as an integral complex in the C₁₄H₂₁N molecule led to a logical inference that this compound would, through pyrolysis, yield a pyridine homologue. In pursuance of this idea the C₁₄H₂₁N molecule was thermally decomposed over an alumina-silica catalyst to produce quantitatively 2,3,6-trimethylpyridine [9]. This experiment led to a like pyrolysis of a 270–80° C. fraction of residual bases from which had been separated the C₁₄H₂₁N compound, 2,3- and 2,4-dimethylquinoline, and 2,3,8- and 2,4,8-trimethylquinoline.

In view of the fact that all the above bases may be readily converted to phthalones, their removal by this method was attempted prior to pyrolysis of the residual bases. This led to the unexpected and important discovery that the residual bases themselves, for the most part, could be readily condensed with phthalic anhydride. From this observation it can be inferred that numerous bases, until now classified as *non-aromatic*, contain the complex,



The true nature of these residual bases which defied further separation by fractionation was elucidated in an experiment where 115 c.c. of the material in gaseous form was slowly passed over a long layer of catalyst at 600° C. The distillate, measuring 53 c.c., was fractionated by one ordinary distillation through a reflux column, followed by one amplified distillation, into the 13 fractions tabulated below [9].

Physical Constants of Pyrolysed Bases

Number of fraction	Volume c.c.	B.P. (°C.) 746 mm.	$\frac{25}{D}$
1	4.7	172	1.4962
2	4.3	186	1.5045
3	1.6	199	1.5232
4	2.2	218	1.5482
5	2.3	242	1.5558
6	4.2	253	1.5564
7	5.0	261	1.5538
8	6.1	265	1.5528
9	4.6	270	1.5550
10	4.5	277	1.5623
11	4.2	279	1.5630
12	1.2	281	1.5678
13	3.2	293	1.5844

* All following reference numbers are *References—Appendix numbers.

Here the original $n25/D$ 1.5123 was changed in the distilled pyrolysis fractions to $n25/D$ values, ranging from 1.4962 to 1.5844. The decided elevation of refractive indices, beyond fraction No. 2, clearly indicates that pyrolysis increased the unsaturation of certain bases through dehydrogenation. It may be inferred that pyridines ($n25/D$ around 1.5) and quinolines ($n25/D$ around 1.6) constitute, in the main, the pyrolysis distillate. The source of the quinolines was apparently Bz-dihydro, or more probably Bz-tetrahydroquinoline homologues derived from

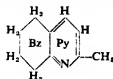

These preliminary pyrolysis experiments point the way to the identification of numerous petroleum bases, which have defied separation, as such, but which can now be converted to substances that lend themselves to purification through fractional recrystallization of a wide variety of salts.

At present, pyrolysis studies are in progress throughout the entire range of base fractions from straight-run distillates, and pyridine as well as quinoline homologues have been obtained from several fractions below the 270° C. range.

High-pressure reduction and pyrolysis establish conclusively that the $C_{14}H_{18}N$ molecule contains the complex,



to which must be united the remaining eight carbons at positions 4 or 5, or they may be partitioned to both of these positions. The possibility of open chain complexes, such as a pentyl and an alkyl, completing the $C_{14}H_{18}N$ molecule can be disregarded, because, it is certain that type of compound would readily reduce alkaline permanganate.

Equally untenable is a structure with a six-membered ring condensed at positions 4 and 5, with four additional carbons as alkyls on the Bz-nucleus, for example:

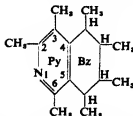

Here is revealed a Bz-tetrahydroquinoline homologue, on which pyrolysis could effect dehydrogenation, coupled, it might be, with partial dealkylation, but in any event the binuclear ring structure would remain intact.

There is left, as the most acceptable interpretation, a condensation of the pyridine nucleus with a five-membered ring, substituted by five carbons in the form of alkyls. Of the several possibilities from which to choose, the naphthenic structure,

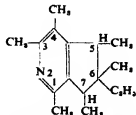

is proposed provisionally because the two hydrogens

located at positions 5 and 7 are in favourable location for migration to the pyridine ring, thereby facilitating intermolecular disruption to 2,3,6-trimethylpyridine. In this formula the methyls at positions 1 and 3 account for the parallel in chemical behaviour of this naphthenic base and 2,4-dimethylquinoline. However, in view of the well-known use of alkaline permanganate in structural proof of pyridine homologues, the anomalous property of resistance to alkaline permanganate oxidation [12, 1931] was not to be expected.

This stability and the failure to obtain evidence of unsaturation in the molecule, apart from two reactive methyls, led to a 'provisional' structural formula, admittedly 'highly speculative', and through which was advanced the fanciful assumption of a 'neo-carbon system' imparting 'aromatic character' to a completely saturated cyclic base.

Apparently, high-pressure reduction will prove a reliable method in determining the state of saturation of all petroleum bases. It now appears probable that the $C_{12}H_{14}N$ base [2, 1933] previously referred to, is not completely saturated, despite its resistance to alkaline permanganate oxidation. The tetrahydropyridine,

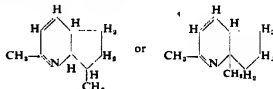

to which three carbons as alkyls must be added in order to complete the formula, $C_{12}H_{14}N$, will be subjected to high-pressure reduction in an effort to verify the provisional structural formula.

One of the formulae listed above may apply to a $C_{10}H_{14}N$ kero base [11] lately isolated in the Texas Laboratory. This new substance reacts very slowly with methyl iodide, even at water-bath temperature, and through this property may be easily isolated in pure form as the methiodide. It is resistant to pyrolysis, a property which may be due to its low state of alkylation as compared with that of the 13- and 16-carbon bases, considered above. In view of its ability to reduce alkaline permanganate this explanation appears all the more plausible.

From Fig. 1 it is observed that the peak volume of kero bases occurs in the 270–80° C. range; while Fig. 2 discloses, that although the major peak volume of gas-oil bases exists between 300–10° C., a secondary peak is found in the 270–80° C. range.

Basic nitrogenous material extracted from cracked gasoline produced in cracking gas oil from California petroleum has been found to contain nine basic products, including quinoline, quinaldine, and seven pyridine homologues [4, 1937]. Since there is every assurance that no base, present beyond negligible amount, was overlooked in this investigation, it may be concluded that only aromatic bases, such as pyridines and quinolines, will be encountered in cracked distillates. The pyridines in the cracked gasoline must have resulted from thermal degradation of more complex polynuclear types, while the quinoline and quinaldine were probably produced through dehydrogenation and dealkylation of dialkyl- and trialkyl-hydroquinoline homologues.

Depending on the reversible reactions,

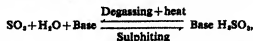

an economical method of extracting nitrogen bases from

hydrocarbon oil has been developed [10]. 'Sulphiting' is effected by agitation of petroleum distillates with water containing the desired amount of sulphur dioxide. In practice, 'sulphiting' is carried out on successive batches of oil, with the sulphurous acid solution intermittently recharged with sulphur dioxide. In this way a 'sulphite brine' of sufficient concentration to warrant 'degassing' finally results. A temperature of 70–100° C. is employed in dissociation of the acid sulphites. The liberated bases separate as a supernatant layer, and are drawn off, thus permitting the water layer to be re-used in further extractions. Where 'sulphiting' and 'degassing' are carried out interchangeably in two separate units it is evident that the sulphur dioxide liberated by 'degassing' in one unit may be used for 'sulphiting' in the other by simply allowing the gas to be absorbed in the water solution in the 'sulphiting' chamber.

In the pyridine series the base acid sulphites dissociate

which at an elevated temperature dissociates according to the equation:



The more common salt contains two moles of base hydrochloride in union with one mole of zinc chloride, a type of salt originally employed in purification of 2,8-dimethylquinoline through sublimation of its hydrochloride:

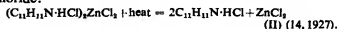

In the absence of hydrochloric acid, however, zinc chloride unites with nitrogen bases of the quinoline and pyridine series to form, in the main, salts of the type (Base)₂ZnCl₂, which dissociate on heating to yield the free base and zinc chloride.

In practice, zinc chloride or its aqueous solution is added to the base or mixture of bases and, after salt formation is

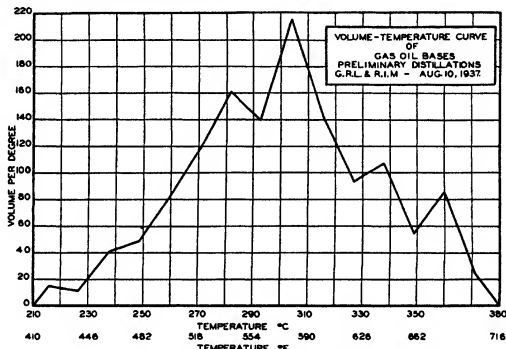

FIG. 2. Volume distribution of gas-oil base.

very slowly, even at a temperature of 100° C., and this stability of pyridine acid sulphites may be used to advantage in sharp segregation of pyridines from other petroleum bases. For example, in 'sulphiting' nitrogen bases from cracked gasoline, pyridines are allowed to accumulate in the 'sulphite brine' while other base types are removed through 'degassing'. Finally, the pyridine bases are liberated from their salts with caustic in the usual way. When it is considered that pyridine and its methyl derivatives are either miscible with water in all proportions or appreciably soluble in it, it is seen that the proposed method of base extraction is to be recommended where pyridines are concerned. 'Sulphiting and degassing', furthermore, is more efficient than cumulative extraction in concentrating pyridines, since the hydrochlorides of pyridine bases have practically the same solubility in water and chloroform.

Two reactions involving thermal dissociation of zinc chloride salts which, until lately, have been only of scientific interest, have been applied to purification of petroleum bases [9]. The process combines in a single operation the simultaneous removal of water, thio compounds, hydrocarbon oil, and other non-basic admixtures. Pyridine, for example, unites with zinc chloride to form a crystalline salt

complete, water and other volatile products are removed by distillation at a relatively low temperature. At a much higher temperature, around 320° C., the zinc chloride salts dissociate to yield a distillate of pure anhydrous bases, while the non-volatile zinc chloride remains behind ready for re-use.

This process is of special value in dehydrating pyridine which forms with water an azeotropic mixture boiling at 92–3° C. and having the composition, C₅H₇N·3H₂O.

Whereas dehydration of petroleum bases outside of the pyridine series is of no importance because of their difficult solubility in water, the removal of sulphur compounds (5, 1932; 7, 1932) and hydrocarbon oil—since they accompany all crude fractions of petroleum bases—is very desirable. Numerous experiments have confirmed the high efficiency of the zinc chloride process in this direction.

The latest publication from the Texas Laboratory deals with 'I. Germicidal Properties of Nitrogen Bases from Transformer Oil Extracts' [3, 1937].

A forthcoming publication [6] will deal with isolation and synthesis of a new kero base, 2,3-dimethyl, 8-ethylquinoline. This is the first kero quinoline encountered with an alkyl other than methyl, and it is probable no petroleum base contains an alkyl higher than ethyl.

REFERENCES

1. ARMENDT, B. F., and BAILEY, J. R. *J.A.C.S.* **55**, 4146 (1933).
2. BAILEY, J. R., and co-workers. *Ind. Eng. Chem.* **20**, 83 (1928); *J.A.C.S.* **52**, 1240 (1930).
3. BILLY, G. *J.S.C.I.* **10**, 120 (1891).
4. BIGGS, B. S., and BAILEY, J. R. *J.A.C.S.* **55**, 4141 (1933).
5. BRATTON, A. C., FELSING, W. A., and BAILEY, J. R. *Ind. Eng. Chem.* **28**, 424 (1936).
6. BRAUN, J. *Von. Ann.* **478**, 182 (1930).
7. DECKER, H., and DUNANT, G. *Ber.* **42**, 1178 (1903).
8. DOJA, M. O. *Chem. Reviews*, **11**, 278 (1932).
9. EGUCHI, T. *Chem. Zentr.* **100** (1), 331 (1929).
10. JOHNSON, T. B., and DASCHANSKY, P. G. *J. Biol. Chem.* **62**, 197 (1924).
11. KING, W. A., and BAILEY, J. R. *J.A.C.S.* **52**, 1245 (1930).
12. KOENIG, W., and MENDEL, A. *Ber.* **37**, 1322 (1904).
13. LACKEY, R. W., and BAILEY, J. R. *J.A.C.S.* **56**, 2742 (1934).
14. LAKE, G. R., and BAILEY, J. R. *J.A.C.S.* **55**, 4143 (1933).
15. LADENBURG, A. *Ber.* **16**, 2059 (1883); **17**, 772 (1884).
16. MABERY, C. F. *J.S.C.I.* **19**, 505 (1900).
17. MABERY, C. F., and WESSON, D. *J.A.C.S.* **42**, 1021 (1920).
18. PARKER, IVY, GUTZEIT, C. L., BRATTON, A. C., and BAILEY, J. R. *J.A.C.S.* **58**, 1097 (1936).
19. PERKIN, T. S., and BAILEY, J. R. *J.A.C.S.* **55**, 4136 (1933).
20. PICTET, A., and CRAMER, M. *Helv. Chim. Acta*, **2**, 188 (1919).
21. THOMPSON, W. C., and BAILEY, J. R. *J.A.C.S.* **53**, 1002 (1931).
22. THOMPSON, W. C. *J.A.C.S.* **53**, 3160 (1931).
23. WHITMORE, F. C., and FLEMING, G. H. *J.A.C.S.* **55**, 4161 (1933).

REFERENCES—APPENDIX

1. Acknowledgement is due to Dr. Homer Adkins for carrying out this reduction. His report of a consumption of 6 hydrogens per mole of base has been confirmed.
2. ARMENDT, B. F., and BAILEY, J. R. *J.A.C.S.* **55**, 4146 (1933).
3. AXE, W. N., HENSON, D. D., and SCHUHARDT, V. T. *Ind. and Eng. Chem.* **29**, 503 (1937).
4. BRATTON, A. C., and BAILEY, J. R. *J.A.C.S.* **59**, 175 (1937).
5. Hydrierwerke Aktien Gesellschaft. D.R. Patent 541,923 (16 Jan. 1932).
6. KEY, C. L., and BAILEY, J. R. Manuscript has been submitted for publication.
7. KNUBER and SCHMITT. D.R. Patent 551,606 (2 June 1932).
8. LANG, W. *Ber.* **21**, 1572 (1888).
9. MAHAN, R. I., and BAILEY, J. R. Publication at a later date.
10. MAHAN, R. I., BARNES, C. D., MEADOWS, J. L., and BAILEY, J. R. Publication at a later date.
11. ROBERTS, S. M., and BAILEY, J. R. Publication at a later date.
12. THOMPSON, W. C., and BAILEY, J. R. *J.A.C.S.* **53**, 1002 (1931).
13. TAFEL, J. *Ber.* **25**, 1619 (1892).
14. WYLER, M. *Ber.* **60**, 398 (1927).

INORGANIC CONSTITUENTS OF PETROLEUM

By W. H. THOMAS, A.R.S.M., M.Inst.P.T.

Chemist, Anglo-Iranian Oil Company, Ltd.

In general, the amount of inorganic matter present in petroleum is minute in comparison with that present in solid fuels, and therefore for the majority of uses it can be, and has been, ignored. For certain purposes, however, the ash and its components are important; in the glass-making industry, for example, the vanadium content of fuel oils should be low, owing to the serious defects which may accrue due to the occlusion of vanadium in the molten glass. In the main, therefore, petroleum ash is of interest either from the point of view of some particular element which may be obtained from it on a commercial scale or from its geological significance, which at present is more academic than practical.

Where the ash from a given oil is of value due to the presence of a particular component such as vanadium, the most convenient and satisfactory method for its production is from the flue dust of furnaces in which the oil is used as a fuel. For solid bituminous materials a modification of this type of procedure would be necessitated, as in the case of the vanadiferous asphalt of Peru which has been the subject of tests with a view to its industrial utilization. For general analytical purposes, however, the most suitable procedure is to reduce the oil to a heavy residue and to burn the latter in air from some suitable container such as a silica dish. The residue of coke is then reduced to ash by placing the dish in a muffle furnace, taking care that its temperature is not high enough to cause fusion of the ash on to the silica. A somewhat more precise method, which avoids the loss of particles of ash during burning, consists in distilling the oil to coke in a silica flask, followed by combustion of the coke in the flask in a steady stream of air or oxygen. The effluent gases are passed through a pair of wash bottles containing distilled water, thereby retaining ash particles which may have been removed by the flow of air or oxygen. The ash so retained may be recovered by filtration, or preferably by evaporation of the water. Another method for the determination of ash content [8] has been described, in which a known weight of oil is allowed to flow drop by drop on to the sides of a platinum dish heated to dull redness. The use of platinum vessels for the preparation of the ash is not to be recommended, owing to the undesirable reactions which may take place between the ash and the platinum at the temperature of combustion of the coke.

The actual yield of ash can rarely be related to the type of oil from which it is obtained, although, in general, oils of high gravity and viscosity have the higher ash contents. In many cases the ash contents of oil vary according to the degree of settling and the position in the container from which the sample is taken. Filtration of normal well-settled samples of oil prior to their reduction to ash, even in extreme cases, rarely removes more than half the inorganic matter present, the material removed usually consisting of silica, iron oxide, lime, &c., or in other words, that type of material which is acquired due to inclusion of wind-blown dust and tank and pipe scale in the oil subsequent to its production. This would suggest that the portion of the ash which is indigenous to the oil is either in colloidal suspension, possibly in the form of sulphides, or

exists partly in the form of liquid organic compounds. Fester [9, 1927] in reporting the work of the Bergin Gesellschaft states that on purifying Mexican crude oil by filtration through an absorbent, the sulphur was eliminated and all the vanadium absorbed. It was therefore deduced that the vanadium existed in the oil in the form of a colloidal suspension of the sulphide.

Ash Analyses

Crude	California	Wyoming	Mid-Continent	Texas	Pennsylvania	Kansas	Oklahoma
	[20]	[20]	[20]	[20]	[20]	[20]	[20]
	%	%	%	%	%	%	%
SiO ₂	38.8	40.3	31.7	1.6	0.8	10.0	..
Fe ₂ O ₃ , Al ₂ O ₃ and TiO ₂	17.3	51.4	31.8	8.9	97.5	19.1	..
CaO	8.7	3.5	12.6	5.3	0.7	4.8	..
MgO	1.8	1.2	4.2	2.5	0.2	1.3	..
MnO	0.3	0.2	0.4	0.3	0.2	trace	..
V ₂ O ₅	5.1	trace	trace	1.4	..	0.4	22.1
NiO	4.4	0.3	0.5	1.5	nil	0.6	5.9
Na ₂ O	9.5	2.6	6.9	30.8	0.1	23.6	..
K ₂ O	1.0	..	0.9	..
Li ₂ O	0.1	0.2
SO ₂	15.0	1.4	10.8	42.1	0.9	36.4	..
P ₂ O ₅	..	0.1
Cl	4.6	..	0.1	..

	Iranian crude oils			English	
	a	b	c	Flue dust	Hardstoft
	%	%	%	[22]	[22]
Ash	0.005	0.003	0.006	%	%
SiO ₂	52.8	18.1	12.1	2.2	13.4
Fe ₂ O ₃ , Al ₂ O ₃ and TiO ₂	13.1	37.1	18.1	27.0	62.9
CaO	6.1	8.7	12.7	2.3	12.8
MgO	9.1	3.8	0.2	1.2	5.6
MnO	trace	trace	trace	4.4	..
V ₂ O ₅	14.0	24.9	38.5	5.7	..
NiO	1.4	5.3	10.7	2.0	..
SO ₂	2.6	1.0	7.0	35.3	..
P ₂ O ₅	5.5	2.3

also traces of Ba, Sr, Sn, Mo, Cu, Mn

Owing to the diversity of elements which may be present, quantitative chemical analyses of samples of ash in many cases prove both difficult and tedious. Moreover, the amounts of certain constituents are too small to be easily detected by normal qualitative tests. The pressure of high percentages of a particular element, e.g. vanadium, frequently cause difficulties in the determination of other elements with which it is associated. A very convenient scheme of general analysis, however, is that published by the Fuel Research Board [4], although it was originally intended for the analysis of coal ash. For general investigation purposes, spectrographic analysis is perhaps the

most valuable and convenient tool for the research worker, for with suitable technique it will detect the most minute quantities of elements which would be entirely missed by chemical methods, and it is of course the presence of the more unusual elements which is of greatest interest with regard to the examination of petroleum ash. Although quantitative spectrographic analysis is less exact than chemical methods for the major constituents, it is possible to develop a quantitative technique for the minor constituents on a comparative basis which in many cases is more accurate than normal chemical methods and can easily be made the equal of micro-chemical procedures. The 'Ratio Quantitative System' described by Lewis [15, 1932] should be particularly applicable in this connexion.

Very few complete quantitative analyses of petroleum ashes have been published, but as will be seen from the data collected in the tables, most investigators have contented themselves merely with the identification of the elements present in the sample.

As an addendum to the above data, mention should be made of the statement of Dunstan [7, 1924] that the ash from Iranian crude oil exhibits a small degree of radioactivity, 15 g. of ash showing about two-thirds of the activity of 0.1 g. of uranium nitrate. Similarly, Bogoyavlenskii [1, 1929], dealing with the radioactivity of some ashes from well-waters associated with crude oils, has shown that radioactivity is approximately inversely proportional to the amount of ash in the well-waters.

Perhaps the most notable feature of the above analyses is the variety of elements which may be present in petroleum ash. If the ash had originated solely from the strata from which the oil is obtained, then the constituents would probably have been the same as those of the reservoir rock and in similar proportions thereto; for example, silica, oxides or complex silicates of iron, aluminium, and titanium, calcium and magnesium carbonates, and sulphates, &c. The relatively high concentrations of some of the more unusual elements shown in the above table indicate that this could not have been the case and that their concentration could only have been brought about by some agency connected with the actual formation of oil. It is now generally conceded that petroleum has originated either from animal or from vegetable remains, and hence it is logical to assume that these organisms during their life were largely the medium of concentration of the elements concerned. Hackford [13, 1922], for example, considers that these materials have been collected from sea-water by absorption into the bodies of marine algae which subsequently were transformed into petroleum. Further support to this view has been given by Vinogradov [24, 1934], who states that vanadium is known to occur in small quantities (10^{-3}) in various terrestrial and marine animals and plants. In two groups of marine animals, ascidians and holothurians, which absorb vanadium as a substitute for copper and phosphorus in their blood, it has been found in high concentrations. Since sea-water contains very small quantities of vanadium, it appears probable that the source of the vanadium found in ascidians is marine bottom muds which are often rich in that element. Moreover, these animals form highly specialized biocoenoses on the sea floor, and after their death they should enrich the bottom sediments with vanadium. It is suggested, therefore, that oils containing this element are connected in their origin with marine sediments formed under conditions favourable to organisms capable of concentrating vanadium.

Qualitative Examinations

Crude oils	Ash	Elements identified
Canadian [8]	..	Fe, Al, Ca, Mg, and traces of Au and Ag
Ohio [8]	0.11%	Fe, Al, Ca, Mg, and traces of Au, Ag, and Cu
Mexican [13]	0.72%	Si, Fe, Al, Ti, Mg, Na, V, N, Sn, Pb, Co, and Au
Jugy [3]	..	Fe, Ni
C. Rivadavia [3]	..	Fe, Al, Ni, and V
P. Huincol [3]	..	Fe, Al, Ni
Patagonian [8]	0.2%	P, Cu, N, K
Japanese [8]	0.16-0.55%	Si, Fe, Ca
Chidiersynde [8]	0.09%	Al, Cu, Pb, and traces of Ag and S
Baku [8]	0.09%	Si, Fe, Ca, Al, Cu, S, P, As, and traces of Ag, Au, Mn, and Pb
Egyptian [8]	0.12%	Fe, Ca, Ni, and V
Venezuelan	..	Fe, Ni, V (38-45%)
Iraq [12]	0.11%	Fe, Ni, V
Texas [20]	..	P, As, and S
" [12]	..	Si, Fe, Al, Ti, Ca, Mg, V, Ni, small amounts of Ba, Sr, Mn, Pb, Cu, and traces of Cr and Ag

Asphalts	Ash	Elements identified
Lobsann [8]	5.4%	Si, Fe, Cu, S, and traces of Mn
Patronite [14]	..	V
Andes [21]	..	V (43%)
Peru [14]	..	V
Nevada [2]	..	V (30%)
Manjak (Trinidad) [2]	..	V
Asphaltite (Utah) [14]	..	V and U
Grahamite (Oklahoma) [14]	..	V
Rafaelite (Acua Mahuida) [3]	..	Fe, Al, V, and Ni
<i>Shales</i>		
Scotch [10]	..	V
Joadja Creek [10]	..	V
Lignite (Travancore) [5]	..	V
Lignite (San Rafael) [2]	0.63%	Si, S, V (38%)
Somerset (England) [19]	..	Si, Fe, Al, Cu, Mg, and S
<i>Coals</i>		
San Rafael [2]	..	V (39%)
Peru [2]	..	V (38%)
Melargue [3]	..	Fe, V, Ni

Certain plants use vanadium as a substitute for phosphorus [16], and nickel has been detected in a very fertile soil at Pantchero near Belgrade, which seems to indicate that very minute quantities are actually beneficial to plants. Nickel, moreover, amongst other elements has been detected in the ash obtained from seaweed. It is significant, on the other hand, that although nickel and vanadium are widely disseminated throughout the earth's crust, there appears to be no relationship between commercial deposits of these metals and those of petroleum. Ramsay's [18, 1924] postulation regarding the presence of nickel in petroleum ash is very germane to this subject. He states that nearly every type of petroleum contains nickel in varying proportions, and he has put forward the suggestion that the nickel has acted as a catalyst in the hydrogenation of the original material in the formation of petroleum. Obviously, it cannot be stated specifically whether the nickel occurs in the

metallic state or not. Nickel is never found in the earth's crust in the metallic state, but always in combination with some other element such as arsenic or sulphur. It is difficult to understand, therefore, how hydrogenation can take place when it is realized that in catalytic hydrogenation, nickel in the metallic state is essential and, moreover, in a specially active, finely divided condition. Apart from this, the elements with which nickel is usually found in combination would effectively inhibit catalysis by reason of their poisoning action.

The presence of molybdenum in certain ashes is of considerable interest, especially if one considers its striking catalytic effect on hydrogenation reactions which, unlike that of nickel, is still operative even in the presence of sulphur compounds. Its derivation, however, is even more difficult to postulate, for it may be classed as one of the rarer elements in the earth's crust. It has been found to be present in a large variety of terrestrial plants [6, 1934], although even by use of spectrographic analysis it could not be detected in the soil in which the plants grew.

Continuing this review of the possible origin of the elements present in petroleum ashes, it should be noted that crustaceans are rich in zinc, and this element, together with copper, is found in the blood of molluscs. Certain protozoans segregate barium sulphate, and some radiolaria form their skeletons in part from strontium sulphate.

Generally speaking, the analyses show a notable absence of the volatile elements, but it cannot be assumed that they are absent, for the conditions of preparation of the ashes would normally cause their loss by volatilization. Longobardi [17, 1934] in fact considers that 'the fields to be explored in future investigations are those of the volatile elements, the radioactive compounds and the isotopes'.

With regard to the more common elements, in the absence of data on the effect of filtration of oils on ash content, it is almost impossible to say whether they are adventitious or indigenous to the oil. Iron may have originated from ferruginous rocks or from pipelines and tanks, and aluminium, titanium, and silica may have been derived from arenaceous and argillaceous strata or may equally well have been acquired in the form of wind-blown dust. Again, the presence of relatively high proportions of calcium and magnesium would suggest solvent action on calcareous and dolomitic rocks.

In some of the analyses the phosphate radical is by no means the least important constituent, and here again the phosphorus may either have been derived from rocks containing phosphatic compounds, or from infiltrated well-water. An example of the latter is the fact that ammonia, both free and albuminoid, and phosphates have been detected in some samples of well-waters. Whether these components have been derived from infiltrated surface water, or whether their presence indicates the pre-existence of abundant animal life from which the oil was formed, is a matter which only extensive research will decide. According to Engler [8] the presence of this element may be due to the reduction of the phosphorus content of animal detritus.

It is the presence of vanadium and nickel which has evoked the greatest amount of comment and conjecture, the former having been detected in petroleum for the first time by Longobardi and Comus [17, 1934]. It will be appreciated from a perusal of the ash analyses that vanadium is associated particularly with asphalt or asphalt-containing oil, non-asphaltic oils such as Hardstoft or Pennsylvanian apparently containing no vanadium. Thus, in those cases where asphaltic constituents have been concentrated by weathering or by inspissation of crude oil, the resulting natural asphalts are rich in vanadium. Shirey [20, 1931] dealing with the ashes obtained from American crude oils suggests that, although there is an insufficiency of data, it would appear that high contents of vanadium and nickel are generally associated with asphalt-base crudes. It is pointed out that there is a loose quantitative ratio between the vanadium and nickel contents of the ashes analysed. While nickel apparently occurs to some extent in the ash from all crudes, vanadium appears to associate itself more strictly with those of asphaltic nature and may appear only in minute traces or probably not at all in some of the paraffin-base crudes. Vernadsky [23, 1934] has stated that vanadium is found in three types of fields, in asphalts which are always genetically related to petroleum, the percentage of which is increased with its transformation into asphalt. In modification of Engler's [8] theory, Fester [9, 1927] suggests that vanadium might be regarded as an element indicative of petroleum and as a guide to the investigation of its origin. He has, moreover, prepared a genealogical table which traces the history of vanadium via solution from igneous rocks by water, thence by precipitation in contact with iron and nickel, finally being converted to the sulphide by bacteria present in mud and animal and vegetable remains which formed the 'mother-material' of petroleum, asphalts and shales. Longobardi [17, 1934] points out that if Fester's hypothesis be correct, then the precipitation of vanadium and nickel in the form of sulphides would take place under shallow water conditions, and the catalytic hydrogenation by means of nickel as postulated by Ramsay would have occurred earlier, this precluding the possibility of the catalytic poisoning effect of arsenic and sulphur.

The presence of vanadium in oil or asphalt is not limited to any particular country or oilfield, which again suggests that vanadium is connected in some way with the genesis of petroleum, and more detailed analyses, preferably carried out by spectrographic means, might even show that some other of the rarer elements were also persistently present in oils from varying sources. Such analyses, complete in detail, especially with regard to minor constituents, would have considerable geological significance when applied to problems concerning the origin and migration of petroleum and to the correlation of crude oils and seepages of different types existing in the same tectonic area or stratigraphic sequence. The above remarks will serve to indicate how little the conjectures given are substantiated by actual evidence, and what a large field for research is opened up by systematic investigation on this subject.

REFERENCES

- 1 BOGOVAYLENKIN *Neft Khoz* 17, 91 (1929)
- 2 CLARKE *Data of Geochemistry*
- 3 CORTI *Argent Bur Minn*, Publication 18 (1926)
- 4 Dept Scienc Ind Res Fuel Research Paper, 28
- 5 DEWHURST, T. *J I P T* 9, 243 (1923)
- 6 DINGWALL, KIBBIN, and BEANS *Canad J Res* 11, 32 (1934)
- 7 DUNNETAN, A. E. *J I P T* 10, 71 (1924)
- 8 ENGLER, C. *Das Erdöl*
- 9 FEYER, G., and BERTUZZI, F. *Bol Ac Nat de Ciencias de Córdoba*, 30, 120 (1927)
- 10 Geol Survey Memoirs *Oil Shales of the Lothians*
- 11 GERSHVICH *J Chem Ind (Russia)*, 6, 205 (1929)
- 12 GURWITZ, L., and MOORE, H. *Principles of Petroleum Technology*
- 13 Hackford, J. E. *J I P T* 8, 193 (1922)
- 14 Imp Min Res Bur Pamphlet on Vanadium
- 15 LEWIS, S. *J Chem and Ind* 51, 271 (1932)
- 16 LINDGREN *Econ Geol*
- 17 LONGOBARDI, E. *Argent Chem Soc* 117, 5 (1934)
- 18 RAMSAY, W. *J I P T* 10, 87 (1924)
- 19 SHATWELL, H. G., NASH, A. W., and GRAHAM, J. I. *J I P T* 10, 876 (1924)
- 20 SHIREY, W. B. *Ind Eng Chem* 23, 1151 (1931)
- 21 SUTHERLAND, D. A. *J I P T* 9, 237 (1923)
- 22 THOMAS, W. H. *J I P T* 10, 216 (1924)
- 23 VERNADSKY *Argent Chem Soc* 117, 5 (1934)
- 24 VINOGRADOV, A. *Nature*, 134, 855 (1934)

COLLOIDICS

COLLOID AND CAPILLARY CHEMISTRY OF PETROLEUM

By H. FREUNDLICH, Ph.D.

Honorary Research Associate, University College, London

Introduction

RECENT investigations seem to show definitely that petroleum has been produced from organic matter in the course of geological periods. It may be considered to be a product formed at fairly low temperatures (below 300° C), since it contains substances such as complicated porphyrin compounds which would have been destroyed at higher temperatures [76]. Pure petroleum is a solution containing a very great number of substances, practically all carbon compounds. In raw petroleum also inorganic substances may be found, emulsified droplets of aqueous solutions, &c. The bulk of the solution is made up of hydrocarbons. Samples of petroleum of different origin may be strongly different as to the nature of these hydrocarbons and of all other substances present, the Pennsylvanian oils are, for instance, specially rich in paraffin hydrocarbons, those of Baku in naphthenes. It is, therefore, necessary to be very careful when attempting to generalize the results gained with one kind of petroleum. Colloidal properties are not very pronounced in natural petroleum, though the presence of substances having particles of colloidal size must most likely always be taken into account. Artificial colloidal systems, using petroleum as the medium of dispersion or as disperse phase, are technically valuable. The capillary chemistry of petroleum, i.e. phenomena correlated with its surface tension and interfacial tension, with adsorption and surface reactions are likewise important.

I. Substances in Colloidal Dispersion contained in Petroleum

The question whether petroleum contains always or generally substances in colloidal dispersion cannot yet be answered with any degree of certainty. An investigation with the ultramicroscope does not give a definite answer [71]. Since there are substances present having marked fluorescence [8], a cone of light is visible as a rule. This fluorescence is also the cause why the diffracted light does not show the state of polarization characteristic in colloidal systems. More delicate experiments which would allow a distinction between the light caused by fluorescence and by diffraction do not seem to have been attempted. This has been done, for instance, in the case of linseed oil, by illuminating with red light [24]. The presence of distinctly visible submicrons in higher concentration has not been confirmed with certainty. They are said to be found in American oil, not in Russian (Holde [51]).

These fairly negative results do not prove much. It is nevertheless possible that particles of colloidal size are present in petroleum; they may be so small that they are not visible in the ultramicroscope, or, since visibility strongly depends upon the difference in the refractive index of the medium of dispersion and the disperse phase, this difference may be too low. The latter cause is perhaps more probable than the former.

There are a few other phenomena which seem to favour

the assumption of substances in colloidal dispersion. Colloidal solutions frequently show anomalies in their viscosity. These may be of very different kind; for example, it may be impossible to determine a normal viscosity coefficient owing to the fact that laws such as Poiseuille's law for the flow of liquid through a capillary do not hold. Or there may exist a normal coefficient of viscosity, but it is not constant and changes in course of time. Cases of anomalous viscosity are known for petroleum, for instance, for the viscosity of Mexican oil [16]. At low temperatures the viscosity of the oil increases markedly at 0° C; the change amounts to 20% of the original value in 6 days, whereas it decreases at higher temperatures, at 34° C it decreases by about 11% in the same time. An oil which has become very viscous by ageing may always be brought back to its original low viscosity by being heated for a sufficiently long time. Changes of this kind are frequently found in such colloidal solutions which have a tendency to form a gel at low temperatures, whereas they are transformed into a sol again at higher ones. But the fact that the addition of about 10% of an oil of low viscosity causes these anomalies to disappear makes this explanation not very probable.

Another anomaly of viscosity was described by Bulkey and Bitner [9] in the case of a paraffin-base oil after having been cooled below the pour-point, the rate of flow was not constant at steady pressure. It increased till a certain limiting value was reached, then it first changed reversibly with the change of pressure.

The following experiments are perhaps the most weighty in favouring the supposition that matter in colloidal dispersion is present [68]. Most oils contain substances, the so-called asphaltic matter, which may be precipitated simply by adding petroleum ether. It is improbable that this way of precipitation should cause any chemical change in the nature of the substance precipitated. Now this asphaltic matter has distinctly colloidal properties: treated with aromatic hydrocarbons, their halogen derivatives, CS₂, &c., it swells and then dissolves, forming lyophilic solutions. In aliphatic hydrocarbons it is insoluble. Asphaltic matter is considered to be a condensation product of the resinous matter found in petroleum. The resinous matter has a strong reddish-black colour and a fairly low molecular weight, it is in true solution. The asphaltic matter, when being precipitated from the oil by petroleum ether, adsorbs the resinous matter pronouncedly.

According to investigations by Sachanen and his collaborators [69] the paraffin waxes are generally in true solution, in agreement with results of L. Gurwitsch [31], they show a well-defined solubility in a great number of organic solvents only depending upon the temperature.

The problem of colloids in petroleum might be attacked with the following method, which has proved fertile when investigating the very similar question, whether linseed oil is colloidal or forms colloidal products when oxidized [55]. Solutions of petroleum in suitable organic liquids might

be filtered through ultra-filters, a method which perhaps would allow one to fractionate the substances according to their degree of dispersion

II. Capillary Chemistry of Petroleum

1. Phenomena concerning Liquid Surfaces and Interfaces.

Since petroleum is a solution containing a large number of substances, its surface tension may have fairly different values. It has not been investigated very systematically so far. According to measurements by C. K. Francis and H. T. Bennett [21], who used the method of an adhesion ring, developed by Lecomte du Nouy, the values for American oils of different origin are between 28.8 and 31.2 dyn/cm at 29.4° C. Winchester and Reber [21] found a linear decrease of the surface tension with temperatures between 80 and 300° C in the case of lubricating oils. Gurwitsch [30], using the method of drop number, found for a series of Russian oils values between 20.4 and 36.0 dyn/cm at 20° C.

The surface tension of petroleum diminishes in the usual way with increasing temperature. Francis and Bennett have determined it between 15.5 and 32.2° C, the decrease was not so strictly linear as is the rule in pure liquids. But on applying, nevertheless, the well-known equation

$$\sigma_s = \sigma_s [1 - \gamma(t_s - t_1)] \quad (1)$$

— σ_s and σ_s being the values of the surface tension at temperatures t_1 and t_s —a temperature coefficient $\gamma = 0.0039$ is found, a value which agrees fairly well with those of similar organic liquids (the value for benzene being, for instance, 0.0035).

The interfacial tension towards water (and aqueous solutions) shows a more characteristic behaviour than the surface tension. Gurwitsch [30] and Johansen [47] have determined it, measuring the drop number, in the cases of transparent oils the drops of water were formed in the oil, whereas in opaque oils drops of oil were pressed into the water. Pound [63] measured interfacial tensions, using the method of capillary rise. The following table, extracted from results of Johansen, records the values of interfacial tension σ_{PW} of 'pure' oils and of such containing foreign substances, for instance, lubricating oils with oleic acid or samples of petroleum which have been exposed to daylight for a certain time in presence of air, and which, therefore, are rich in oxidized products.

TABLE I
 $t = 25^\circ \text{C}$

Substance	Treatment	σ_{PW}
White medicinal oil		54.9
" "		18.5
Water-white kerosine	exposed to daylight 40 days	49.0
" "		34.9
Lubricating oil	exposed to daylight 45 days	53.4
" "	containing 1% oleic acid	30.1
" "	containing 10% oleic acid	17.2

Whereas 'pure' petroleum may be considered to consist mainly of hydrocarbons, whose molecules have no 'composite surface', the oxidation products such as naphthenic acids, etc., and substances such as oleic acid have 'composite surfaces', having distinct hydrophilic and hydrophobic regions; in the latter case, for instance, the hydrophilic carboxyl group has a strong affinity to water, the chain is

hydrophobic. Substances and molecules with a composite surface will always be referred to as active substances or molecules. Molecules of this type are often called 'polar', a term which may easily be misunderstood. For it is generally applied to characterize the dipole moment of a molecule, as it is derived from the dielectric constant. But this polarity must be sharply distinguished from the degree of compositeness of the molecular surface, as it shows up, for instance, in the capillary activity of the molecules. The dipole moments of different alcohols, for example, are practically the same from methanol to normal hexyl alcohol they vary irregularly between 1.62 and 1.66×10^{-18} c.g.s. units, yet the capillary activity of hexyl alcohol, according to Traube's rule, is 3^{1/2}-times greater than that of methanol. They are strongly adsorbed at interfaces towards water and aqueous solutions, and are oriented there, the hydrophilic group lying towards the water, the hydrophobic turning away from it. This phenomenon will be discussed more thoroughly later on.

Orientation is the reason why interfacial tension of oils is so much more sensitive towards foreign substances than surface tension, in the latter case the oil borders on a hydrophobic medium such as air (or any other gas), and there is no reason for any orientation. The difference in the behaviour of surface and interfacial tension is shown by the following experiments (Johansen) when lubricating oil which always contains active substances is filtered through flint (Fuller's earth), the active substances are strongly adsorbed, and both surface and interfacial tension increase on account of this purification, but the change is much greater in the case of the interfacial tension σ_{PW} (13.2 than in that of the surface tension σ_s (0.4) (cf. Table II, columns 3 and 4).

TABLE II

Substance	Treatment	σ_s	σ_{PW}	ν
Lubricating oil		31.3	29.4	73.9
" "	The same filtered through Fuller's earth	31.7	42.6	61.6
Kerosene naphthenic acids		31.8	1.88	102

The affinity of the active substance to the aqueous phase can be expressed quantitatively by calculating the so-called adhesion work per cm². This is the amount of free energy ν in excess, when, by forming 1 cm² of interface 1 cm² of the surface of each of the two liquids disappears [38].

$$\nu = \sigma_W + \sigma_P - \sigma_{PW} \quad (2)$$

Here σ_W is the surface tension of water, σ_P that of petroleum, σ_{PW} the interfacial tension. Taking σ_W at 25° C to 72 dyn/cm, values of ν are found as recorded in Table II, column 5: the adhesion work is larger in an oil with impurities of an active character; it decreases on filtering. In pure oil it is still smaller: assuming the σ_P of a white medicinal oil to be 31 dyn/cm—according to the values determined by Francis and Bennett, mentioned above—its adhesion work would amount to 48.1 dyn/cm.—using the value of σ_{PW} recorded in Table I.

The strong influence of active substances upon the interfacial tension is also the factor instrumental in the spreading of petroleum on water and aqueous solutions. If a drop of petroleum is brought upon a surface of water, it may remain there in the form of a lens. On the outside of its boundary there is the surface tension of the water σ_W ; inside the boundary $\sigma_P + \sigma_{PW}$ acting in an opposite direction.

If these forces are equal, there will be a state of equilibrium. If there is an excess of the one or the other,

$$F_s = \sigma_w - \sigma_p - \sigma_{pw}, \quad (3)$$

the oil will spread over the water, provided that F_s is positive; it will contract to a lens, whose shape only depends upon the forces of gravity, if F_s is negative. F_s is called the spreading coefficient [39]. Owing specially to the high value of σ_{pw} , pure petroleum, mainly consisting of hydrocarbons, has most likely often a negative value of F_s and thus contracts to a lens on the surface of water. This has been shown, for instance [50], for a paraffin oil (Squibbs petroleum), where at 20°C the following values were found: $\sigma_p = 31.1$, $\sigma_{pw} = 55.3$, and $F_s = -13.7$ dyn/cm, for tetradecane $C_{14}H_{30}$, the corresponding values were (at 25°C) $\sigma_p = 26.9$, $\sigma_{pw} = 51.3$, and $F_s = -6.2$ dyn/cm.

But if the oil contains active substances, one has to deal with a very different behaviour. Active substances, having composite surfaces, such as higher fatty acids spread on water and form those characteristic layers which have been investigated so thoroughly by Langmuir [48], Adam [1], Rideal [67], and others. These phenomena cannot be discussed here in detail, only a few main points may be mentioned. If the concentration of the active substance in the surface is very small, the latter may behave there like a gas in a two-dimensional space, following a law similar to the laws of Boyle and Gay-Lussac in gases or of van't Hoff in dilute solutions. If the concentration in the surface is higher, one may have the very well-defined condensed state of the layer: the active molecules stand parallel to each other, upright in regard to the surface, with their hydrophilic group towards the water, their hydrophobic group turned to the air. The orientation may be so regular that each molecule occupies the same space in the surface, whatever its chemical nature may be, provided, for instance, that the CH_3 group always forms the end group outside. A third state which is frequent and important is that of the so-called liquid expanded films, they have been explained by Langmuir [51] as duplex films, the upper and lower boundaries of the film behaving as surfaces with different properties.

As mentioned above, presumably all kinds of active molecules, and thus the oxidized compounds, present in petroleum, are oriented on suitable surfaces and interfaces. These active molecules therefore spread also on the interface water/oil and cause a lowering of its interfacial tension. How strong this decrease in interfacial tension may be is proved by the values of σ_{pw} and σ for kerosene naphthenic acids recorded in Table II, column 3 (Gurwitsch). If the interfacial tension of the layer composed of adsorbed active molecules is σ_{12} , that of the pure oil being σ_{pw} , the tension to spread at the interface is

$$F_{12} = \sigma_{pw} - \sigma_{12}, \quad (4)$$

As soon as this positive value of F_{12} becomes equal to the negative spreading coefficient F_s of the pure oil, the lens of oil is not stable any more, but spreads over the aqueous surface [50]. Already Miss Pockels [62] has shown that petroleum containing an active substance such as mastic spreads over water, whereas pure petroleum concentrates on the surface as a lens. This applies quite generally to all cases where petroleum contains active substances produced by oxidation or other chemical reactions.

The calming of waves by oil also depends upon the spreading power of the oil [1]. Pure oils are not very efficient. They may be improved by adding active sub-

stances such as stearic acid. This effect of an oil film is not simple, it appears to be caused chiefly by the damping of ripples, due to the resistance of separate film islands, when being contracted or expanded, and other factors absorbing energy.

The interfacial tension of pure petroleum decreases likewise with rising temperature. The function is again practically linear. In experiments by Johansen, mentioned above, the coefficient γ amounted to 0.0017.

2. Phenomena in Presence of Solid Surfaces and Interfaces.

(a) *Wetting and Lubrication.* It is impossible to describe the capillary chemistry of petroleum on solid surfaces with a similar degree of certainty as can be done for liquid surfaces. In the latter case the characteristic behaviour of the interfacial tension enables us to explain most of the phenomena observed. There is no general method known to determine the interfacial tension between a solid and a liquid—nor the surface tension between the solid and a gas—although it is necessary to assume that similar forces are active.

It is only possible to measure the so-called adhesion tension γ , i.e. the difference between the interfacial tension of a solid A and a liquid $A-\sigma_{sA}$ —and the same solid and a liquid B [σ] $-\sigma_{sB}$.

$$\gamma = \sigma_{sA} - \sigma_{sB} = \sigma_{sB} \cos \theta \quad (5)$$

The adhesion tension may be found by measuring the pressure necessary to prevent the displacement of the one liquid by the other from the surface of a solid powder or by determining the angle of contact θ at the interface of the two liquids on the solid surfaces and the interfacial tension σ_{sB} . Both methods have been used and the results agree satisfactorily.

Generally one has to be content with qualitative experiments. One may investigate the spreading of a liquid on a solid surface in a gaseous atmosphere, or when the surface is covered with another liquid [64]. The wettability found in this way may also be determined by shaking the finely powdered solid in the liquid in presence of the gas or of the second liquid, and testing whether it is wetted entirely by one or the other liquid or remains on the surface or the interface [44].

Contrary to the behaviour on water, pure petroleum, paraffin oils, &c., spread better on solid surfaces such as glass, metals, &c., than a petroleum containing 'active' substances or an active oil, such as olive oil [61]. There is probably an orientation of the active substance at the interface and on the border-line of the oil lens, but the rigidity of this oriented layer and of the surfaces coming into play most likely prevents that easy spreading found on the mobile liquid surfaces. In all experiments of this kind it is very uncertain whether a state of equilibrium has been reached or whether one is dealing with complications due to the fact that the rate of wetting is so very sensitive to the presence of impurities, &c.

The displacement of one liquid by another, used for measuring the adhesion tension, is of technical interest in so far as oil contained in oil-bearing sands is obtained by flooding the sand with water or aqueous solutions, this method being more efficient than other methods of operation. Water does not work as well as alkaline solutions, for instance, solutions of Na_2CO_3 , &c.

Bartell and Miller [4] doubt whether the superiority of alkaline solutions is only due to a higher adhesion tension

towards silica. These doubts are founded on the lack of correlation in the following quantitative experiments concerning the displacement of organic liquids from silica by water and aqueous solutions in the case of petroleum and aqueous solutions in the case of petroleum; on the other hand, the interfacial tension of the aqueous solution/petroleum is much smaller in the case of the alkaline solution, presumably owing to the formation of a very capillary active, soap-like substance, when the alkali reacts with substances contained in the oil. With benzene the adhesion tension is also larger in alkaline solutions, but the interfacial tension does not decrease, it is even a little larger than with pure water. The authors, therefore, consider a chemical reaction of the alkali and the silica to be a more probable cause of the specific action of the alkali [59]. This reasoning does not seem quite conclusive. Under technical conditions only the dynamic values of the interfacial tensions are effective, i.e. the dynamic values of σ_{12} and σ_{23} (cf. equation (5)) and a correlation with the static value of σ_{12} need not be surmised.

The spreading of oils on solid surfaces and the formation of oriented films are of paramount importance in lubrication. The viscosity of the lubricating liquid is only decisive as long as the bearing pressures are low and the speed high. With high pressures and low speeds it soon became evident that another property was essential, which was called oiliness. Vegetable and animal oils had a higher oiliness than pure mineral oils, oils of high oiliness had a smaller interfacial tension towards water and aqueous solutions than oil lacking this property [79]. It is obvious that active substances were instrumental in causing oiliness. Investigations by Rayleigh [65], Hardy [36], Woog [82], Trillat [77], Langmuir [52], and others make the following mechanism very probable. The active substance contained in the oil forms oriented layers on solid surfaces of glass, metals, &c. The molecules are oriented in such a manner that the hydrophilic group is turned towards the solid surface, the hydrophobic CH_2 group away from it, and the effect on lubrication is bound to the fact that smooth surfaces of CH_2 groups, having a small mutual affinity, easily glide upon each other. These layers are not monomolecular, but presumably polymolecular, quite a number of thin, crystalline sheets, each having a thickness of only one molecule, are lying like in a pack of cards parallel to each other and to the solid surface. This was proved by investigating lubricating layers of fatty acids, fats, and mixtures of vaseline and fatty acids with X-rays [77]. When the solid surface is prone to react with the active substances, for instance, in the case of metals and fatty acids, an investigation with X-rays shows that also the topmost layer of the metal is changed, oriented layers being produced there too. That solid surfaces are easily covered by several oriented layers was proved by Langmuir [52] in another way: he dipped a glass slide repeatedly in a suitable manner into water covered by a monomolecular layer of stearic acid, these layers on glass may have a different sense of orientation: in the odd ones a hydrophilic group is turned towards the glass, in the even ones an orientation in the opposite direction prevails as long as the surface is sufficiently wet.

As mentioned above, the natural tendency of oil to spread on surfaces of metals, &c., is not so great that it may be relied upon in forming these layers causing oiliness. To produce them an external mechanical force has to be exerted [7], the two solid surfaces being made to glide in opposite direction on each other. One is dealing with a

case of orientation of a substance on a solid surface similar to another well-known case, where dyestuff layers are oriented by polishing them on glass surfaces [83]. Therefore it takes some time till the lubricating action of oil becomes conspicuous, and it is evident that the way experts test the oiliness of an oil by rubbing it for some time between their fingers is also from the theoretical point of view the right thing to do. Langmuir [52] has shown that the lubricating film may be worn off rapidly when exposed to wear, and that with a monomolecular layer this occurs very much quicker than, for instance, with a film that is seven layers thick. Thus the thickness of a lubricating film is important, and also all factors which favour a rebuilding of the film when it has been worn off. Concerning the latter point, the presence of an oil with saturated molecules may be valuable, since it spreads more easily, as mentioned above, and therefore may transport active molecules dissolved in it always anew into the space to be lubricated.

(b) *Adsorption in Petroleum.* The adsorption of substances dissolved in petroleum on solid surfaces is another important process where capillary chemistry comes into play [32]. Cases of adsorption have been mentioned already: the adsorption of resinous matter on asphaltic matter, when the latter is precipitated within the oil, and the adsorption of active substances, such as naphthenic acids, &c., on fuller's earth. Adsorption is chiefly applied to purify natural oils by removing substances which are not welcome. Very different kinds of solid adsorbents are used, such as flonidin, silica gel, alumina, active charcoal, &c. Dyestuffs such as the resinous matter and sulphur compounds are the two classes of substances which may be removed from the raw oil by adsorption. One is dealing with so many substances of different kinds, and in part of unknown constitution, that it is impossible to give a concise account of these phenomena. It is, furthermore, doubtful whether one is really investigating true adsorption, the solutes being bound reversibly by the solid adsorbents, or whether a chemical reaction is favoured on the solid surface, and causes the formation of new insoluble substances. Reactions of this type occur very commonly in the chemistry of petroleum, they will be treated later on. The lack of reversibility may also be due to an adsorption of colloidal substances dispersed in the oil from the outset or formed by reactions on the surface.

Yet there are factors which seem to prove that adsorption is anyhow one stage in the process going on when solid powders interact with petroleum. For instance, the well-known ordinary adsorption isotherm is found to hold very frequently

$$a = \alpha c^{1/n} \quad (6)$$

a is the adsorbed amount per unit of solid powder, c the concentration of the solute in equilibrium with the adsorbed amount, α and $1/n$ are constants. This equation could be applied to the decolorization of oil by adsorbents such as bauxite, clay, charcoal, &c. [19]. The amount adsorbed a is derived from the change of colour due to adsorption, the concentration c from the colour of the oil after adsorption. In a logarithmic diagram equation (6) is represented by a straight line, since

$$\log a = \log \alpha + (1/n) \log c \quad (6a)$$

In this way the validity of equation (6) is tested. The coefficient $1/n$ is generally smaller than 1, as is the rule in ordinary adsorption. In some cases $1/n$ was found to be markedly higher than 1, which is unusual in true adsorption. It is not possible to draw any conclusion from

this observation, since the systems dealt with are too complicated.

A great number of adsorbents have been tried and are in practical use. The following extract from a table given by Dunstan [20] and referring to a 0.25% solution of a crude asphaltic oil in benzene records the number of c.c. decolorized by the same amount (1 g.) of solid powder

TABLE III

Adsorbent	c.c. of coloured solution decolorized
Alumina	60
Floridin	30
Bauxite	30
Ignited peat	15
Bone charcoal	14
Bog iron ore	12
Ferric oxide	10
Ball clay	8
China clay	2
Kieselguhr	2

These figures do not allow us to compare the true adsorptive power of these solid substances. One would have to know the specific surface of each powder to do this, and to use in such experiments not the same weight of adsorbent, but amounts having the same surface. It is not easy to determine the specific surfaces, and it does not seem to have been attempted in adsorption experiments of this kind. But it may be concluded from Table III that a hydrophobic adsorbent such as charcoal is not so strongly superior to all other adsorbents, as is the case in aqueous solutions. Hydrophilic adsorbents such as alumina, floridin, bauxite, &c., compete successfully with it. This is chiefly due to the fact that petroleum represents a very different type of medium, an extremely hydrophobic one. The adsorption in different media with different kinds of adsorbents may be understood qualitatively by taking into account the competition between the molecules of the solute and medium at the surface [27]. The molecules of a strongly adsorbable medium have a tendency to displace those of the solute, the adsorption of the solute will therefore be small in such a medium, whereas it will be strong in a medium whose molecules are poorly adsorbable. The adsorbability of the medium may be judged to a certain extent from its heat of wetting. Hydrocarbons have a much greater heat of wetting with charcoal than with floridin, whereas it is greater for floridin with water than with an

adsorbent more strongly by charcoal. The following example proving this behaviour may be mentioned: crystal violet dissolved in tetraline is adsorbed more strongly by silica gel than by charcoal, in aqueous solution the charcoal is a more powerful adsorbent. But much too little is known as to the difference of adsorbability between solute and medium to allow any quantitative prediction, or even to say how different solutes may be arranged as to their adsorbability on different kinds of adsorbents.

Adsorbents such as silica gel, floridin, &c., are furthermore specially suitable for adsorbing sulphur compounds. According to Wood, Sheely, and Trusty [80] they may be arranged in a series silica gel > floridin > alumina. Yet not all sulphur compounds found in the oil are strongly adsorbed. Markedly adsorbed are dimethyl sulphate, diphenyl sulphoxide, and *n*-butylsulphone, whereas free sulphur, hydrogen sulphide, and carbon disulphide are not adsorbed at all, other sulphur compounds are adsorbed to a certain extent.

Since one is always dealing with an adsorption in systems containing a great number of substances of very different kinds, the possibilities of a displacement of one substance by another on the surface are very manifold. It is therefore easily understood that the behaviour of different adsorbents is distinctly specific. This is not in contradiction to the assumption that these phenomena are due to adsorption also in pure solutions of one substance: the amount adsorbed does not only depend upon the size of the adsorbing surface, but also upon the value of the forces of attraction active on the surface.

Regarding the adsorption of other substances the following facts may be mentioned: unsaturated compounds are strongly adsorbed, thus the unsaturated ring hydrocarbons reacting with formaldehyde in the so-called formalite reaction are strongly adsorbed by floridin [43]. The adsorption of the resinous matter has been treated briefly already. An efficient method to remove it from the oil consists in shaking it with adsorbents such as charcoal or floridin, it may be extracted from the adsorbent not by benzene but by benzene or chloroform, solvents in which evidently the resinous matter is less adsorbable [45]. It is also adsorbed on paraffin [78]. The asphaltic matter is likewise pronouncedly adsorbable on floridin, bauxite, &c. High molecular paraffins appear to be more adsorbable than polynaphthalenes when a molten mixture is treated with floridin [33].

The adsorptive power of adsorbents may be changed by a suitable previous treatment, but since so little is known about the properties of a solid surface decisive for a strong adsorptive power, it is not easy to say anything definite about these results. As an example may be mentioned that, according to Dunstan [18], the adsorptive capacity of bauxite for sulphur compounds is lost if the bauxite is heated and cooled *in vacuo*. Freshly heated, it regains its adsorptive power.

In the case of bauxite, presumably also in that of other adsorbents, there is a parallelism between the adsorptive power and the heat of adsorption. Since the latter is easily determined by measuring the rise of temperature under suitable conditions when adsorbents and oil are mixed, this method is used for determining and comparing the adsorptive power of different samples of bauxite.

When applying adsorption technically the oil is filtered through the adsorbing mass.

Goppelsroeder's method of capillary analysis has also been applied to petroleum. The oil was allowed to rise in

TABLE IV

Liquid	Heat of wetting (g.-cal) for 1 g. adsorbent	
	Floridin	Charcoal
Water	30.1	18.5
Methanol	21.8	17.6
Amyl alcohol	10.9	10.6
Benzene	5.6	11.1
Hexane	3.9	8.9
Petroleum (b.p. 220-225° C.)	5.3	13.4
Benzene (b.p. 80-85° C.)	4.2	9.5

organic solvent. Owing to this fact, floridin will be, on the whole, a stronger adsorbent in petroleum (or any other hydrocarbon) than in water, whereas charcoal will prevail in water; in petroleum the solute is less hydrophobic than the hydrocarbons, and is therefore liable to be adsorbed more strongly by floridin, in water an organic solute is more hydrophobic than the medium and is therefore

a column of flonidin [12] The unsaturated hydrocarbons and sulphur compounds had a tendency to be kept back, and the oil which could be displaced from the flonidin by water had a smaller density when a portion was taken from the top than when it was taken from below These changes are chiefly due to adsorption, but not entirely capillary analysis is a complicated phenomenon which does not only depend upon an adsorption equilibrium, but also upon dynamical processes such as velocity of capillary rise, &c Processes similar to those active in capillary analysis may be instrumental in causing differences in the composition of oils, which have had to pass through layers of adsorbing materials in the earth

As mentioned above, chemical reactions on the surface of adsorbents are very frequent when oils are treated with substances such as flonidin, &c Some of the most remarkable cases of surface reactions have been found here (L. Gurwitch [28]) Flonidin catalyses the polymerization of the resinous matter into the asphaltic matter, whereas silica gel does not do so [70] It acts in a similar way upon hydrocarbons having double bonds (olefines, diolefines, &c) and therefore upon mineral oils or products of cracking containing such compounds [29] According to Lebedew and Filonenko [54], the hydrocarbons must have a special structure in order to be liable to react in this way as to ethylene compounds only those react with flonidin which are asymmetrically substituted in one or two places, compounds containing only one substitute or being substituted symmetrically in two or four places do not react In agreement with this rule isoprene is polymerized by flonidin The substances formed are true polymers [75] In the case of iso-butylene $\text{CH}_2=\text{C}(\text{CH}_3)_2$, for instance, a tri- and penta-iso-butylene are formed and a poly-iso-butylene with an average molecular weight of 1,460 containing about 26 single molecules The latter substance is highly viscous and amorphous, looking like an ointment A remarkable reaction of this type is found when flonidin acts upon α -pinene [34] a maximum effect is reached with a flonidin with about 8% of water, the temperature may rise from 18.5 to 161°C when the pinene is added Dipinene and polyterpenes are formed among the polymerization products The water structurally bound in the flonidin takes an active part in this reaction Iron oxides, silica gel, and active charcoal do not react in this way with pinene When considering these results, it seems a remarkable fact [17] that amylene is polymerized to di-amylene both by flonidin [26] and by sulphuric acid

The adsorption of vapours has likewise found technical application in the petroleum industry Gasoline has been recovered from natural gas by adsorption on activated charcoal [10] The natural gas is passed through the adsorbent till the latter has taken up about 15% of its weight The gasoline is then driven out by treating the charcoal with saturated steam

III. Colloid Systems with Petroleum as a Medium of Dispersion or as a Disperse Phase

The question whether natural petroleum as such is a colloidal system was discussed in section I In this section chiefly those systems will be treated where foreign substances represent the one phase, petroleum being the other one Systems of this kind may occur in Nature some kinds of petroleum contain an enormous quantity of aqueous solution, and it turns out to be an important technical problem to break these frequently most stable

emulsions The majority of systems which are going to be discussed are artificial products, suspensions of graphite or coal in petroleum, or systems where the disperse phase consists of the oil

1. Emulsions containing Petroleum.

Emulsions are disperse systems where both phases are liquid The droplets of the disperse phase may be of colloidal size (diameter below 0.5μ), but less stress is generally laid upon size than upon stability, and emulsions with droplets up to 10μ diameter may be quite stable The factors responsible for stabilizing emulsions are not fully known Easily understood is the stabilizing influence of fine, solid powders coating the droplets, these stable surface layers simply prevent the drops coalescing In a similar way the emulsifying action of colloids may be explained, they being absorbed at the interface and forming protective layers there But in order to act in this way the colloid films must coat the surface of the droplets outside, not inside In the case of an oil-water emulsion—drops of oil in an aqueous medium—hydrophilic colloids as alkali soaps, gelatin, &c, are strong emulsifying agents, being present in the aqueous phase and adsorbed on the outside of the oil droplets In the case of water-oil emulsions—drops of aqueous solution in an oily medium—colloids within the oil phase, such as soaps of divalent and heavy metals of fatty and naphthenic acids, &c, may act in the same way Many of these stabilizing molecules have a composite surface with hydrophilic and hydrophobic groups, and therefore orientation effects may also be instrumental in favouring the action of these emulsifiers The charge of the drops is most likely also of some importance In many cases more than one of these factors is a cause of the stability of the emulsion dealt with

The stability of an emulsion is destroyed if one succeeds in destroying the protective layers This may be done by displacing the substances accumulated at the interface by other capillary active molecules of low molecular weight, which therefore do not produce protective layers If hydrophobic colloids are the protective agents in water-oil emulsions, a sufficient amount of hydrophilic colloids may tend to reverse the emulsion to an oil-water emulsion, this process of reversal also always means a state of low stability A remarkably simple case of this kind may be found with soaps the alkali soaps are hydrophilic colloids and favour oil-water emulsions, Ca and Mg soaps are hydrophobic and favour water-oil emulsions, thus the reversal of a water-oil emulsion stabilized with one of the latter soaps may be called forth by treating it with an alkali solution

The natural petroleum emulsions mentioned above are water-oil emulsions, as was shown by Sherrick [73] They have a very small electrical conductivity, and they ought to have a fairly high one, if they were oil-water emulsions, because the aqueous phase consists of a rather concentrated solution of electrolytes (NaCl, &c), they further mix spontaneously with oil, not with water The amount of disperse aqueous phase may be fairly high, 25% and more The substances causing the high stability of these emulsions are probably in part organic colloids such as asphaltic matter, &c, but also fine earthy material is suspended in the oil and may form those coatings mentioned above

Very manifold methods have been both proposed and tried, and are in practical use for breaking these natural oil emulsions [74] A very simple way consists in heating the oil in open vessels by means of a steam coil and thus evaporating the water. More efficient is to heat up to 130°C.

under pressure Under these conditions the rigidity of the films round the droplets seems to be destroyed, owing perhaps to the fact that the adsorption is generally strongly decreased at higher temperatures, or that substances are formed which are less adsorbable, the droplets, therefore, coalesce more readily Electrical forces may be applied too, both direct and alternating current When using direct current the droplets are transported to one of the two electrodes, owing to the low conductivity of the oil the distance between the electrodes must be small (about 5 cm), the voltage high (250 volts) When alternating current—voltages up to 10,000 volts—is applied the droplets orient themselves, forming chains, and being thus arranged more closely unite more easily to larger drops It is not quite obvious how this behaviour is to be explained In both cases an action of cataphoresis might be taken into account likewise when using alternating current, for the latter is also able to move and orient suspended particles and thus to favour the coalescence of drops But petroleum being so good an insulator, it seems more probable to attribute these effects to electrostatic forces and consider them as somewhat analogous to the so-called Cottrell effect in fogs and smokes [11]

A separation by centrifuging is used frequently, the oil is slightly heated to lower its viscosity Capillary methods are also joined to centrifuging In agreement with the theoretical views discussed above, strongly capillary active substances may be used such as phenols, &c, which are adsorbed at the interface and displace the substances forming the films, or hydrophilic colloids, soaps of fatty and sulphonic acids, glue, &c, which tend to reverse the emulsion In the latter case it may be advisable to add substances which make it easier for these substances to pass through the oil Na-oleate is mixed with oleic acid, a preparation patented for this purpose (Tret-O-Lite) contains Na-oleate plus small amounts of phenol, paraffin wax, and Ca-resinate

An interesting method which has been proposed is based upon the fact that emulsions may be separated by filtering [40], the liquid, which is the medium of dispersion, being able to pass the filter, if it wets the filter material, the second liquid remains on the filter In the case of water-oil emulsions substances such as pyrites or vulcanized rubber may be taken as filtering materials, in the case of oil-water emulsions carbonate of lime has proved suitable This method is not used technically, because filters are too easily blocked

Emulsions causing disturbance may also be produced during the process of refining [31] When refining with sulphuric acid, the acid oil, containing sulphuric, naphthenic, sulphonic acids, phenols, &c, is neutralized with a solution of caustic soda These are the well-known ideal conditions for the formation of an emulsion [14] an oil treated with alkali and containing acids such as naphthenic and sulphonic acids, whose salts have a soap-like character, being strongly capillary active and excellent emulsifiers Griffin [14] showed that if kerosene was emulsified in water with Na-oleate, for instance, always a small amount of the fatty acid was dissolved in the hydrocarbon, the film of soap on the droplets was monomolecular The soap is produced at the interface just where it is needed for emulsification, it has not to diffuse to the interface from a certain distance. Emulsification is also pronouncedly favoured, if strong 'diffusion currents' spurt out of the oil into the aqueous phase and then fall apart into minute drops coated with thin films of soap. These soaps are hydrophilic colloids and therefore favour the formation of oil-water emulsions

They are produced, indeed, on neutralizing acid oils, though water-oil emulsions may sometimes originate too The tendency to form emulsions and their stability is markedly influenced by the concentration of the alkali and of the acids, further by the nature and structure of the soap films, &c Concentrated alkali, for instance, is disadvantageous, since the soap is salted out and does not dissolve One cannot make practical use of this fact in oil refining, for too much soap remains in the oil and causes emulsification when it is washed out with water [31] A strong dispersion is only observed at medium concentrations of alkali An addition of oleic or naphthenic acid to the oil has the surprising effect of also preventing emulsification This seems to be due, according to investigations with the microscope, to the formation of a thin, coherent film of soap, this layer prevents a quick interaction of the acid oil with the alkaline solution, the latter only diffusing slowly through the film and causing a kind of swelling and production of so-called myelin films, sausage-like excrescences, which are detached gradually It is obvious from this discussion that different kinds of oils and their distillation products may show great differences as to their tendency to form emulsions, and to the nature of those produced

An emulsion similar in a certain way to some natural oils containing water and earthy material, but carrying, so to say, the constitution indicated there to the very extreme, is the natural asphalt as it is found in the Pitch Lake of Trinidad (Clifford Richardson [66]) It is produced by the interaction of petroleum coming from oil-bearing sands with springs of water containing very fine clay, silica, and various salts (NaCl, Na₂SO₄, FeSO₄, &c) That both liquids are mixed so uniformly is most likely mainly due to the churning action of gases, they accompany the petroleum and evolve from the latter when it approaches the surface The clay-like substance is in part colloidal Since it contains iron, &c, it acts, presumably, as a catalyst, promoting the oxidation of the unsaturated hydrocarbons contained in the petroleum to asphaltic matter The concentration of these substances is so high that the mass, which is soft and liquid when freshly formed, turns hard and pitch-like in the course of time It is evidently a water-oil emulsion, the water (about 29%) being bound to the inorganic material (about 27%), probably the fine particles of clay plus asphaltic matter cover the droplets of the aqueous solution and thus cause a great stability of these emulsions Clifford Richardson was able to reproduce an asphalt of this kind artificially by mixing Bermudez asphalt, not containing mineral matter, with an aqueous suspension of colloidal clay According to Nellensteyn [57] it is not only clay, silica, &c, which is in colloidal dispersion the bitumen, i.e. the purely organic matter of the asphalt free of mineral constituents, contains very fine dispersed carbon Nellensteyn and Roodenburg [58] have determined the surface tension and its temperature coefficient for Trinidad asphalt and its bitumen Above a certain temperature—about 125° C for the asphalt, about 75° C for the bitumen—equation (1) is strictly applicable, γ is 0.0023 for the asphalt and 0.0021 for the bitumen

Asphalt and asphaltic bitumen have become most important because they are applied in a large scale for making dust-free pavements [25]. The asphaltic bitumen generally used is the pitch-like residue of petroleum distillation—coal tar and similar substances are also used for this purpose, but will not be treated here The sheet of organic matter on the roads may be produced in different ways, by spreading the liquid, by mixing it with the stony

aggregates, &c. Generally an oil-water emulsion of the asphaltic bitumen is used with a concentration of about 55 to 65%. Many different kinds of emulsifiers have been proposed and have found practical application colloids such as alkali soaps of fatty and naphthenic acids, resins, &c., then finely powdered substances such as clay and bentonite. The drops dispersed in these emulsions have mostly a diameter of about 2μ . On the whole it does not seem specially difficult to emulsify the asphaltic bitumen and similar substances, although characteristic differences are found between different materials. The main problem is to be sure that the emulsion has the right stability on the one hand, it must be stable enough to keep practically unchanged for a sufficiently long time (six months and more), on the other hand, it must be sufficiently labile, to break, when in contact with the road material, and to give a layer uniting the stony particles. The stability of the emulsions is strongly favoured by the fact that there is only a small difference in density between the medium of dispersion and the disperse phase, the specific density of most grades of asphaltic bitumen not deviating by more than 0.06 from unity. The tendency to sediment is therefore feeble. The tendency to break may nevertheless be sufficiently strong. This is mainly due to the fact that these emulsions are fairly concentrated from the outset. They become still more so when applied practically, the loss in water being chiefly due to evaporation, to a minor extent to a removal by porous stones. The concentration thus soon reaches a critical value where the particles easily coagulate under the influence of mechanical action, such as rolling, &c. That even fairly dilute colloidal solutions may be coagulated by stirring is well known [23]. It would need further investigation to decide whether the factors essential in the latter case (small electrical charge of the particles, aggregation at interfaces, &c.) also hold in the case of these asphalt emulsions.

The viscosity of these emulsions has been investigated thoroughly and was found to show interesting features. A formula

$$\eta_s = \frac{\eta_M}{1 - 2\eta_M/h\phi} \quad (7)$$

could be applied (Gabriel [25]), here η_s and η_M are the viscosities of the emulsion and the medium of dispersion, ϕ is the volume concentration of the disperse phase, and h a numerical factor. This equation is very similar to the one derived by Hatschek [42] for concentrated emulsions on purely theoretical reasoning, the only difference is that in Hatschek's equation $h = 1$. According to Gabriel it is probable that the complication entering by the factor h is in part due to the ability of the disperse asphaltic phase to swell by absorbing water.

The frequent use of emulsions for technical purposes is specially due to the following reason: the amount of substance necessary to produce a special technical effect may be much smaller than the amount of liquid necessary to allow an easy and copious initial distribution, if now the essential substance is emulsified in a cheap and volatile medium of dispersion, the latter may be used, so to say, only as a vehicle which may be removed as soon as its valuable content has been spread in the way desired. That is why emulsions are applied for making dust-free pavements, and for the same reason emulsions of petroleum are used on a large scale as insecticides [81]. A second point is in the latter case also of importance: undiluted 'free' petroleum may be deleterious to the plants sprayed and the medium of dispersion has a diluting effect. It is a well-

known but remarkable fact that mineral oils are very poisonous to insects and other lower animals and their eggs, and practically not noxious to men and the higher animals. Oil-water emulsions are used, since the water is meant to evaporate quickly and to leave a film of oil on the plants. Hydrophilic colloids such as the alkali soaps of fatty and sulphonic acids, resins, &c., are again the emulsifiers mostly added. In general, concentrated emulsions (containing about 80% of oil) are sold, and are diluted to the lower concentrations necessary on the field. Soaps are not welcome as emulsifiers when the water used for diluting is hard, then Ca or Mg soaps are formed, which produce curdy masses and favour the formation of water-oil emulsions. For hard water, therefore, other emulsifiers are applied such as gelatin, caseinates, bentonite, &c., or special mixtures of different kinds of emulsifying agents. Since very different kinds of oil fractions are employed as insecticides and the purposes aimed at are very manifold, it is easily understood that also the range of emulsifiers is very broad.

Lubricating greases are also oil-water emulsions [17], sodium soaps are the emulsifiers, and such a grease may consist, for example, of 80 parts of lubricating oil, 15 parts stearic acid, and 2 parts of caustic soda.

2. Suspensions in Petroleum.

The suspensions with mineral oil as the medium of dispersion contain mainly carbon in one form or another as disperse phase. Since the beginning of the century suspensions of graphite in oil have become more and more valuable for lubricating purposes. The first preparation of this kind was introduced as Oildag [2], similar suspensions (Kollag, &c.) were brought on the market later. Besides Oildag (Trade Mark) aqueous suspensions of graphite like Aquadag (Trade Mark) are used for technical purposes. The concentration of these graphite suspensions is generally about 10%. The particles have in their majority a diameter of 1 to 2μ and are distinctly plate-like. This becomes conspicuous when investigating the suspensions under the ultramicroscope, using a sufficiently wide cell, in order to allow the particles to move freely they show strong scintillations, owing to the fact that their visibility depends upon the direction in which they are illuminated [13]. On account of the orientation of these lamellar particles, the aqueous suspension, Aquadag, shows beautiful silky streaks when stirred.

The favourable influence of graphite upon lubrication seems to be due to several causes [83]. It is presumably adsorbed on metal surfaces, the small plates lying with their large surface parallel to the solid surface. The latter is thus much smoother and more uniform. The layer of graphite has a tendency to adsorb oil and to be wetted by it. Consequently it favours the stability and the renewal of that thin oriented layer of oil which is considered to be instrumental in lubrication. The following behaviour of the heat of wetting seems to prove this assertion: whereas this heat has different values for different oils in the case of a pure metal surface (copper), it is larger and shows much smaller differences on varying the oil when powdered carbon is used.

Suspensions of coal in mineral oil have been proposed as liquid fuel, and this 'colloidal fuel' seems to have been applied already to some extent, specially in the U.S.A. (L. W. Bates [86]). Coal is ground as finely as possible and is peptized with an agent which is known to produce suspensions in an oily medium: soaps of divalent and heavy metals, lime resins; bituminous coal may be peptized by

tar, naphthalene, &c The concentration is brought up to about 55%, a mixture mentioned may consist of 30% of coal, 10% coal-tar distillate, and 60% mineral oil. Several advantages are ascribed to this product: a greater combustion efficiency when compared with the pure mineral oil, the possibility of using all kinds of powdered coal, and a greater ease in quenching burning colloidal fuel, since its specific gravity is higher than that of water. Its flash-point is also raised.

A third, rather similar type of suspensions are the news-inks, as they are used for printing newspapers. Linseed oil and its derivatives, the main constituents of most other inks, are present only to a small proportion in news-inks, the bulk of the liquid phase consists of mineral oils. The black pigment is chiefly carbon black, i.e. finely dispersed carbon produced by combustion of oil, &c., with an inadequate amount of air. These particles are small, their average diameter is about 0.1μ [6]. The concentration of the carbon black in these inks amounts to 10% and more. News-inks are generally markedly thixotropic.

3. Some other Colloidal Systems containing Mineral Oil.

There are still several disperse systems with mineral oil which do not fit, as a matter of course, into the preceding paragraphs.

Vaseline is a system of this kind [31]. It is called natural vaseline when prepared as a purified residue of a crude oil, containing paraffin wax. Artificial vaseline is made by melting paraffin wax and mixing it with a purified, suitable mineral oil. On cooling, the paraffin crystallizes in fine needles, as is seen when investigating it with polarized light in a microscope. Some characteristic properties of vaseline are probably due to the presence of these fine paraffin needles which may in part be present in colloidal dispersion (perhaps not colloidal as to their length, but in thickness). Good vaseline must easily be drawn out into threads, a property frequently found in colloidal systems containing fibrillar particles [46]. The latter are oriented parallel to each other when the thread is drawn out. This is proved by the fact that such a thread is strongly double refracting when viewed between crossed nicols under an angle of 45° to the direction of polarization [22]. The amount of paraffin wax in vaseline is generally about 12 to 13%. The structure of vaseline is somewhat like that of a soft gel, or a 'gel solution' as it is called by Stauffer.

The tendency of paraffin wax to crystallize in the shape of fine needles is in part the cause why concentrated solutions of paraffin waxes readily gelatinize [60]. For instance, a 2% solution of paraffin in benzene may settle to a gel, and the same fact was observed in concentrated solutions of other solvents, *p*-xylene, chloroform, &c. This does not prove that the paraffin waxes in these solutions are amorphous or in colloidal dispersion. It was mentioned above that the solutions of paraffin wax in organic solvents are true solutions. But it is found very frequently that if a substance crystallizes out of a solution, forming a very large number of nuclei, the rate of crystallization, on the other hand, being slow, the enormous network of interlocking microcrystals transforms the whole mass to a jelly-like gel (solutions of an azothine in all sorts of solvents [37], of camphoryl-phenyl-thiosemicarbazol in alcoholic solution [41] &c.). These gels are generally not stable. The crystals grow in course of time and settle. The high stability of vaseline is probably due to the fact that the mineral oil present as medium of dispersion contains substances,

perhaps asphaltic matter, which prevent the further crystallization and increase of size of the paraffin crystals.

Gel-like formations of this kind have sometimes thixotropic properties, at least to a certain degree. S. E. Sheppard and Eberlin [72] describe a 'pressure-still tar' containing a fair amount of carbon particles which had set to a gel, but was liquefied on shaking. It does not seem to have shown that reversible behaviour so characteristic in truly thixotropic systems.

The so-called 'solidified petroleum' is a gel made up with suitable amounts of soaps [15]. Solutions of anhydrous Ca soaps in oil may gel on cooling. Preparations of this kind are also made by mixing petroleum with aqueous soap solutions in suitable concentrations.

Colloid systems of quite a different nature are fogs, consisting of small droplets of petroleum. Their behaviour on exploding when mixed with air has been compared with the behaviour of the vapour under similar conditions [35]. The following facts were ascertained: the lower limit of explosion was the same in the fogs as in the vapour, the combustion was less complete in the fog than in the vapour, and the rate of explosion was lower. These results are readily to be understood. At the lower limit of explosion the rate in which combustion is propagated is small, and the drops have time to evaporate, the combustion really proceeds in a gaseous mixture. When the content as to combustible substance is higher, combustion proceeds more rapidly. The drops have not more time to evaporate entirely, and thus the degree of combustion depends upon the ratio of combustible matter to air. Only when the latter is distinctly in excess, combustion is complete. The same factors are instrumental in causing the rate of explosion to be smaller in the case of fogs.

IV. Gelling Drilling Fluids as Thixotropic Systems

This section is not concerned with the capillary or colloidal chemistry of petroleum in any direct way, but deals with a colloidal phenomenon which has turned out to be most important when boring for mineral oil. Another case where capillary chemistry is important with regard to the recovery of petroleum was mentioned above when discussing the possible part played by adhesion tension in the displacement of oil from oil-bearing sands by aqueous solutions.

When using the rotary drilling method special care has to be taken as to the properties of the drilling fluid [53]. It is advantageous to have a fluid markedly heavier than water in order to seal off gases and to allow rock cuttings to accumulate on the surface. Therefore weighted drilling fluids are applied, i.e. aqueous, not very viscous suspensions of heavy powders such as baryte or haematite. Yet such concentrated suspensions are not very stable, the particles tend to settle quickly, forming hard clods and thus causing disturbances. The best way to keep them suspended, without increasing viscosity unduly, is to add a small amount (2 to 3%) of bentonite or similar clay-like substances which transform the whole liquid into a thixotropic system. As was briefly mentioned, thixotropy implies an isothermal reversible sol-gel transformation: the gel is transformed to a sol on shaking or stirring, and the latter sets again to a gel when left to itself. This phenomenon is even more frequent and important as the well-known non-isothermal sol-gel transformation, as is shown by a gelatin gel which is liquefied on heating and sets to a gel again when cooling down. Bentonite is outstanding in forming

- 66 RICHARDSON, CLIFFORD *J Phys Chem* 19, 241 (1915), *Ind Eng Chem* 8, 4 (1916), *Third Report on Colloid Chemistry*, 98 (London, 1920)
- 67 RIDAL *Introduction to Surface Chemistry* (Cambridge, 1926)
- 68 SACHANEN, A. *Petr Z* 21 1441 (1925), SACHANEN, A., and WASILEW, N, *ibid* 23, 1618 (1927)
- 69 SACHANEN, A. *Petr Z* 21, 735 (1925), SACHANEN, A., and BESTUSCHEW, M., *ibid* 22, 484 (1926)
- 70 SACHANEN, A., and WASILEW, N. *Loc cit* 68
- 71 SCHNEIDER, J., and JUST, J. *Z wiss Mikrosk* 22, 501 (1906), *Holzle, Kolloid-Z* 3, 270 (1908)
- 72 SHEPPARD, S. E., and EBERLIN *Ind Eng Chem* 16, 832 (1924)
- 73 SHERRICK *Ind Eng Chem* 12, 133 (1920)
- 74 — *Ind Eng Chem* 13, 1010 (1921), AYRES, *ibid* 13, 1011 (1921), BORN, S., *ibid* 13, 1013 (1921), MATTHEWS, R. R., and CROSBY, P. A., *ibid* 13, 1015 (1921)
- 75 STAEDINGER, H., and BRUNNER, M. *Helv Chim Acta* 13, 1375 (1930), LEBEDEV, S. V., and KOBILANSKY, G. G. *Ber* 63, 109 (1930), LEBEDEV, S. V., and ORLOV, J. *Gen Chem* (RUSSIAN), 5, 1559 (1935), LEBEDEV, S. V., and BORGMAN, *ibid* 5, 1585 (1935)
- 76 TREIRS, A. *Ann* 510, 42 (1934) Cf also BROOKS, B. T., *J I P T* 20, 177 (1934)
- 77 TRILLAT, J. J. *Compt rend* 181, 504 (1925), 182, 843 (1926), 187, 168 (1928), 188, 555 (1929), *Ann* (10), 6, 5 (1926), *Metallwirtsch* 101 (1928)
- 78 TSCHERNOBUKOW, N. I. *Neft slanc Choz* 8, 640 (1925)
- 79 WELLS, H. M., and SOUTHCOMBE, J. E. *J S C I* 39, 517 (1920)
- 80 WOOD, A. E., SHEELY, C., and TRUSTY, A. W. *Ind Eng Chem* 18, 169 (1926), WATERMAN, H. J., and COLLABORATORS, *Brenn-Chem* 6, 255 (1925), 8, 20 (1927), 9, 37, 397 (1928), WOODWARD, MISS, *Ind Eng Chem* 21, 693 (1929)
- 81 WOODMAN, R. M. *Technical Aspects of Emulsions*, 57 (London, 1935)
- 82 WOOD, P. *Compt rend* 180, 1824 (1925), *Kolloid-Z* 59, 1 (1932), and *loc cit* 61
- 83 ZOCHER, H. *Naturwiss* 13, 1015 (1925)

SECTION 20

PHYSICAL AND CHEMICAL PROPERTIES OF PETROLEUM AND ITS PRODUCTS: DETERMINATION, CORRELATION, AND COLLECTED DATA

VISCOSITY

The Viscosity Characteristics of Petroleum Products and their Determination	D P BARNARD
Viscosity of Gases	E S L BEALE
Viscosity-Temperature Characteristics of Petroleum Products	W R WIGGINS
Viscosity Index and Viscosity Gravity Constant	F DOCKSEY
Anomalous Viscosity	A S C LAWRENCE
The Measurement of plasticity	A de WAELE
The Flow Temperature Method of Determining the Action of Cold on Oils, Greases, and Lubricants, Derived from Petroleum	P WOOG
Viscosity and Pseudo-plasticity	H WEISS and M LOUIS

DENSITY AND REFRACTIVE INDEX

Density, Gravity, and Specific Gravity	D W GOULD
Specific Gravity Correction Factors for Petroleum Oils	E S L BEALE
Correction of the Density and Refractive Index of Hydrocarbons for Temperature	E S L BEALE and T K HANSON
Determination of Density and Refractive Index of Hydrocarbons and Petroleum Products	A L WARD, S S KURTZ JR., and W H FULWEILER
General Relationship of Density, Refractive Index, and Related Characteristics, with Structure of Hydrocarbons	A L WARD, S S KURTZ JR., and W H FULWEILER
Density and Refractive Index of Crude Petroleum, Gasoline, Kerosine, Gas Oil and Fuel Oils	A L WARD, S S KURTZ JR and W H FULWEILER
Density and Refractive Index of Paraffin Wax	A L WARD, S S. KURTZ JR., and W H FULWEILER
Refractive Index of Paraffin Wax	C R SCOTT HARLEY

SPECTROGRAPHIC AND X-RAY APPLICATION

The Application of the Infra-red Absorption Spectra to the Study of Petroleum Oils and Spirits	J LECOMTE
--	-----------

The Application of the X-ray Method to the Study of the Paraffin Hydrocarbons	F FRANCIS and S H PIPER
The Application of the Raman Effect to Petroleum Chemistry	J H HIBBEN
Analysis of Petroleum Spirits Using the Raman Spectrograph	A ANDANT
OPTICAL PROPERTIES	
Optical Activity and Its Significance	C E WOOD
The Application of Magnetic Optical Properties in the Analysis of Hydrocarbon Mixtures	M SCHERER
THERMAL, CRITICAL, AND P-V-T DATA AND THEIR MEASUREMENT	
Apparatus and Methods for Determining Thermal Properties of Petroleum Products	R S JESSUP
Heat of Combustion of Petroleum Oils	D W GOULD
Heats of Combustion of Hydrocarbon Gases	D W GOULD
Combustion Data for Gaseous Fuels	E S L BEALE and P DOCKSEY
Specific Heat and Heat Content of Petroleum Products	D W GOULD
Latent Heat Data for Hydrocarbons, Petroleum Products, and Miscellaneous Substances	E S L BEALE
Thermal Conductivity of Gases, Vapours, and Liquids	E S L BEALE
P-V-T Relationships of Hydrocarbons	P DOCKSEY
Determination of Critical Temperature and Pressure of Petroleum Fractions	L C ROESS
Conversion of Boiling-points of Petroleum Fractions	E S L BEALE
PHYSICAL PROPERTIES AND MOLECULAR STRUCTURE	
Methods of Determining Vapour Pressure, Critical Point, and Vapour Density	O MAASS and J H MENNIE
Determination of the Molecular Weights of Petroleum Fractions	C E HEADINGTON
The Properties of Pure Hydrocarbons	G L EATON
The Physical Constants and Molecular Structure of the Non-cyclic Hydrocarbons	C E BOORD
The Energy of Atomic Linkages in Hydrocarbons	J P WIBAUT
The Dielectric Constant of Petroleum and Petroleum Products	G. M. L. SOMMERMAN
Interfacial Tension	H. WEISS and E. VELLINGER
Interfacial Tension	A. S. C. LAWRENCE
The Application of Physical Methods to the Analysis of Hydrocarbon Mixtures	M. L. I. T. AUBERT
Correlation of the Physical Properties of Petroleum	K. M. WATSON

VISCOSITY

THE VISCOSITY CHARACTERISTICS OF PETROLEUM PRODUCTS AND THEIR DETERMINATION

By D. P. BARNARD, B.S., S M , Ch.E., Sc.D.

Assistant Director of Research, Standard Oil Company of Indiana

VISCOSITY or 'internal friction' is the most important single fluid characteristic governing the motion of liquid petroleum products. In this respect the movements of such materials differ notably from the large-scale motions of other fluids in which internal friction frequently is of secondary importance in comparison with kinetic effects. In the petroleum industry viscosity is of principal interest in the handling and use of lubricating products. It rarely is of much concern where the movements of 'light oil' products are concerned. The principal exception to this lies in the viscosity specifications of furnace oils, Diesel fuels, &c. In the heavier lubricating oils, those containing wax, and in the case of greases simple liquid viscosity effects are complicated by the influence of changes in rate of shear upon physical structure. It is not possible to present a thorough discussion of these most interesting (and important) properties in detail—to do so would require much more space than is available. The present article must be confined, therefore, to the presentation, in the most concise manner possible, of the information necessary to the selection of equipment suitable for general requirements. The investigator in specialized fields of viscosity research is referred to the most pertinent published articles available.

Viscosity may be defined as a measure of the internal resistance to motion of a fluid by reason of the forces of cohesion between molecules or molecular groupings. Its exact significance may be more clearly appreciated from the British Engineering Standards Association statement of Maxwell's definition of the 'coefficient of viscosity' [7, 1929]

'The coefficient of viscosity of a fluid is the numerical value of the tangential force on unit area of either of two parallel planes at unit distance apart when the space between is filled with the fluid in question and one of the planes moves with unit velocity in its own plane relatively to the other'

This coefficient is often referred to as the coefficient of 'absolute' viscosity (see below). On the c.g.s. system, which is that most usually employed, the unit of absolute viscosity is the 'poise' often subdivided into 'centipoises'.

The existence of such a coefficient was first determined empirically by Poiseuille [18, 1840] as the result of a series of researches in which the flow of water through fine capillary tubes was studied. His results may be summarized by the formula

$$Q = K \frac{PD^4}{l}$$

where Q = rate of flow,

P = pressure difference between ends of the tube,

D = diameter of the tube,

l = length of the tube.

The equation for viscous flow may also be deduced from purely theoretical considerations. The reader is referred

to Lamb's *Hydrodynamics* [16] or Barr's *Monograph on Viscometry* [4, 1931] for concise mathematical treatments of this subject [24].

Poiseuille's equation is most frequently written

$$\eta = \frac{\pi Pr^4}{8lV/t} = \frac{Pr}{4V/t} = \frac{F}{S}$$

where η = apparent coefficient of viscosity, poises,

P = pressure difference, dynes per cm²,

r = radius of capillary, cm,

l = length of capillary, cm,

V/t = rate of efflux, cm³ per sec,

F = shearing stress, dynes per cm²,

S = rate of shear, sec⁻¹

From Maxwell's definition it is obvious that the coefficient of viscosity of any true liquid must be a constant and quite independent of the rate of shear involved. Frequently, however, petroleum products do not obey this law explicitly and a variation in apparent viscosity with rate of shear will be noted. This is exemplified in Fig. 1,

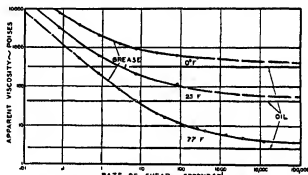

FIG 1 Showing effect of changes in rate of shear upon the apparent viscosity of a product having 'false' body (grease) as compared with a true liquid (oil). Data obtained with Arveson constant shear viscometer. Diagram reproduced by courtesy of *Industrial and Engineering Chemistry*, 26 (June 1934)

which shows the variation in the coefficient of apparent viscosity of a grease with rate of shear in comparison with the oil from which the grease was made. Similar effects are observed with wax-bearing products at temperatures low enough to cause phase separation. 'False' or 'shear' viscosity effects are quite complicated, and their treatment requires detailed and lengthy discussion. Further, their experimental investigation is so highly involved that only in a few laboratories is the necessary apparatus available. For a detailed discussion of this problem the reader is referred to the work of Arveson [3, 1932-4], and other articles in this work [23, 26, 27].

The Coefficient of Viscosity

If M , L , T denote the units of mass, length, and time, the dimensions of a stress are $ML^{-1}T^{-2}$, and that of a rate of shear is T^{-1} , so that the dimensions of η are $ML^{-1}T^{-1}$.

The stresses in different fluids, under similar circumstances of motion, will be proportional to the corresponding values of η , but if we wish to compare their effects in modifying the existing motion, we have to take account of the ratio of these stresses to the inertia of the fluid. From this point of view the determining quantity is the ratio η/ρ , it is therefore usual to denote this by a special symbol ν , called by Maxwell the coefficient of 'kinematic' viscosity. The dimensions of ν are L^2T^{-1} .

As mentioned above, units most usually employed for expressing the viscosity of fluids are those of the cgs system. The unit of kinematic viscosity on this system is the 'stokes', so called after Sir George Stokes. It has usually been found most convenient in work with petroleum products to employ the 'centistokes' which is one hundredth of one stokes.* This is usually abbreviated to cS and is defined by the equation

$$\nu_{cS} = \frac{\eta}{\rho} \times 100,$$

where η = coefficient of absolute viscosity, poises
 ρ = density of fluid (g/cm³)

When units other than the cgs system are employed the following conversion factors given in Table I may be useful.

TABLE I
Conversion Factors for Absolute Viscosity

	g cm sec	kg m hr	lb ft sec
1 poise = 1 g/cm sec = 1 dyne sec/cm ²	1	160	0.0672
1 kg/m sec = 1 kilo dyne hr/m ²	0.002778	1	0.0001867
1 lb/ft sec = 1 poundal sec/ft ²	14.88	5.357	1

Conversion Factors for Kinematic Viscosity

	cm ² sec	m ² hr	ft ² sec
1 cm ² sec = 1 stokes	1	0.36	0.0010764
1 m ² /hr	2.778	1	0.002990
1 ft ² /sec	929.0	334.45	1

Instruments for Measuring Viscosity

In practice viscosities are determined by means of instruments which have been carefully developed and standardized in order to ensure comparable results and a high degree of independence upon the personal element of manipulation. This along with the simplicity requirements of commercial and industrial usage, has served to restrict the useful range of any particular instrument. The most generally used instruments and their ranges over which they are employed are given in the following table.

TABLE II
Instruments for Viscosity Measurements

(A) COMMERCIAL VISCOMETERS

(a) Viscosity Range Limits

	1 to 475 centistokes	Useful range	9.0 to 225
(1) Saybolt Universal	55	5 000	125 600
(2) Saybolt Furol	1	1.55 600	9.0 1 400
(3) Redwood No 1	35	2 800	125 450
(4) Redwood No 2	1.50	3 000	6.0 225
(5) Engler			

(b) Temperature Range Limits

Instrument	Conventional use Temp °F	Lowest useful Temp °F	Highest useful Temp °F
(1) Saybolt Universal	100-130 210	32	210
(2) Saybolt Furol	122 210	77	210
(3) Redwood No 1	70-100-140-200-250	70	250
(4) Redwood No 2	72	32	210
(5) Engler	77 122 210	77	300

(B) LABORATORY INSTRUMENTS

(1) Capillary type

a Ubbelohde 1.0 to 20 000 centistokes with accuracy
 b Ostwald Capillaries are interchanged to give maximum flow
 time of 10 min. Reagents should check within 1 part
 c Vogel-Osag Reagents should check within 1 part

(2) Forced shear

1.0 to 20 000 000 centistokes
 Recommended two instruments
 (a) Suitable for liquids as low as 0.2 cp
 (b) above 2.0 cp

(C) SPECIAL PURPOSE INSTRUMENTS*

- (1) Stormer [4] Chiefly used in the study of consistency of plastic material
- (2) MacMichael Torson type used to cover a range of from about 60 to 2 000 000 centistokes with a precision of approximately 3%.
- (3) Falling spheres [4] Fair precision in higher viscosity ranges. Restricted use due to difficulty of obtaining very small solid spheres of accurate dimensions. Not ordinarily used below 1 000 centistokes. Time may vary from 1 hr to 1 day per determination.
- (4) Rolling spheres: The Höppler [12, 1933] instrument consists of a very accurately made Jena glass tube (16 mm ± 0.002 mm) and accurately ground spheres. The tube is inclined 10° from the vertical. The range of the instrument is wide and can be used at viscosities as low as 0.01 centistokes and on gases.

* All the instruments mentioned measure primarily the absolute viscosity and the results must be converted to kinematic units if required from a knowledge of the density of the fluid.

Although commercial viscometers are capable of working within the range noted it is frequently desirable to know viscosities well outside of these ranges. The range of interest, in, as a matter of fact, very much more extensive than that of the various commercial instruments combined. This is illustrated in Fig. 2 from which it is immediately evident that a very considerable gap must be filled by estimating from viscosities actually measured in the operating ranges of the instruments employed. The range of applicability of the most generally used commercial as well as the more widely employed special purpose instruments is shown in Fig. 3. Of these latter instruments the Ostwald type and the Arveson 'Constant Shear' appear to have the greatest usefulness. As is indicated, a very wide range of viscosities may be covered by the selection of several individual Ostwald instruments having slightly overlapping ranges. This instrument now enjoys a very wide use in the form of various modifications by Bingham, Ubbelohde, and others. The Arveson constant shear viscometer is the most versatile of all, but suffers from the disadvantage that it is exceedingly bulky, expensive, and is relatively slow of manipulation. Its use is justified only for investigations of false viscosity and viscosity determinations either in the range of very high values or where for reasons of exceptional precision requirements the maintaining of absolute control of the rate of shear is essential.

The wider commercial interest in viscosity characteristics plus a rapidly growing demand for improved reproducibility and precision has recently led to the active investigation of the so-called 'suspended level' [19, 1933] instrument. The Ubbelohde is representative of this class, while one of the most satisfactory has been developed by FitzSimons [9, 1935] and is illustrated in Fig. 4. It consists of two capillaries of different sizes, A , sealed into a vapour bath, E . Tube C is an air vent for producing the suspended level, and tube B is connected to the oil reservoir, D .

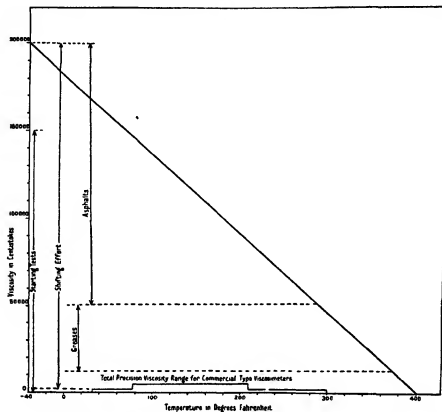

FIG 2 Diagrammatic representation of viscosity-temperature 'field of interest' contrasted with range actually covered by commercial viscometers

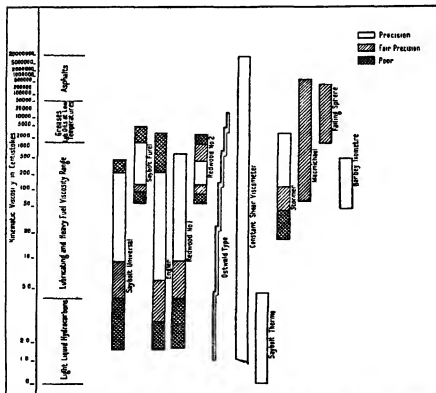

FIG 3 Diagrammatic representation of useful viscosity ranges of commercial instruments

Possible Sources of Error in Viscosity Measurements with Capillary Type Viscometers

The equation for all capillary type viscometers can be expressed by the relation

$$\nu = \frac{rgh^4}{8lv} - \frac{mv}{8\pi l^3}$$

where ν = kinematic viscosity in stokes,
 l = efflux time in seconds,
 g = gravity constant in cm per sec²,
 h = average effective head in cm,
 l = length of capillary in cm,
 v = volume in c.c.,
 m = coefficient in the Hagenbach correction term for kinetic energy
 r = radius of capillary in cm

It can readily be appreciated that as the calibration of a viscometer from its dimensions alone is virtually impossible, calibration is usually done by means of liquids of known viscosities. This leads to the possible introduction of errors from a large number of sources particularly in the case of oil viscometers which have been standardized with water, and where the reference oils employed may be subject to deterioration. Some other sources of error are

(1) **Surface Tension.** The shape taken by a liquid surface will be dependent upon its surface tension, which in a viscometer will vary the effective head of liquid. Errors as great as 2% are possible in some instances. In the case of petroleum oils, calibration with an oil will reduce surface-tension errors to a negligible value. In cases where it is necessary to use the instrument with widely different liquids, such as water and oil, the surface-tension effect may be reduced to a negligible amount by the use of very long capillary tubes.

(2) **Volume Change.** Most viscometers are very sensitive to the exact amount of oil charged. In the Ostwald type viscometers any filling error may be reduced by making the lower bulb of large size, or the use of a long capillary. The Ubbelohde type of instrument is free from any errors due to charging.

(3) **Drainage in Lower Bulb.** This source of error results from varying amounts of oil clinging to the walls and thereby altering the effective head. It is dependent on the viscosity of the oil and the rate at which the oil is drawn up into the upper bulb. This error is avoided in the Ubbelohde type of instrument.

(4) **Drainage in the Upper Bulb.** This source of error, unlike lower bulb drainage, affects the volume term in Poiseuille's equation rather than the height. Hence, in certain instances these two errors nearly offset each other. According to McCuer and Fenske [17, 1935], when dealing with dissimilar liquids the drainage should be determined by the use of an auxiliary bulb of the same size and shape as the upper bulb. This can be done by a procedure of weighing the auxiliary bulb both dry and after a determination.

In the case of similar liquids the possible error is negligible, as the volume remaining is nearly directly proportional to the viscosity and inversely proportional to the efflux time. In a given instrument the efflux time varies directly as the viscosity, hence the drainage is a constant which is taken care of if the instrument is calibrated with similar liquids.

(5) **Alignment.** The sensitivity of Ostwald type instruments to misalignment may be minimized by placing one bulb directly over the other [11, 1905], and in the case of the Ubbelohde instrument by placing the suspended level surface directly under the upper bulb.

(6) **Kinetic Energy.** There is always some uncertainty in

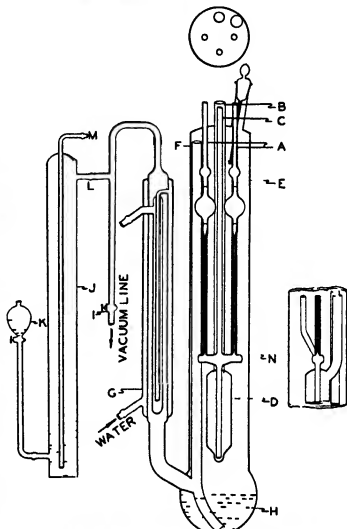

FIG. 4. Suspended level viscometer (modification of FitzSimons)

exact value of the coefficient m , which is dependent on the shape of the capillary openings. The kinetic energy correction can usually be kept small by the use of capillaries giving long efflux times, and it is in any case allowed for in the calibration of the instrument.

(7) **Gravity Correction.** This correction is ordinarily embodied in the calibration factor for a given instrument, but in the usual efflux type of viscometer the calibration factor depends essentially on the value of g in the locality in which the viscometer is used and variation from the standard value should be allowed for.

(8) **Timing Errors.** Starting and stopping errors of an average stop-watch may be as great as 0.4 sec., due to the fact that the actual movement of the watch is not continuous. In no case is one justified in reading a watch to a closer division of a second than the beat of the watch.

For precision timing, it is now possible to obtain watches in which the balance wheel beats as high as 50 times a second. In general, with a good $\frac{1}{4}$ -sec watch, timing errors become negligible for efflux times above 200 sec.

(9) Temperature The effect of temperature measurement errors depend on the temperature of test and the temperature-viscosity characteristics of the liquid. Temperature control to 0.02° F is generally necessary to keep viscosity value errors below 0.1%, but the effect of temperature error is very much greater in the case of high-viscosity oils.

Viscometer Conversion Tables

The conversion of instrument readings to actual viscosity units and interconversion between instruments has been made the subject of much study by individuals and by international standardizing bodies. The current adopted practices are summarized in Table III.

TABLE III
Instrument Conversion Equations

- (1) Saybolt Universal—A S T M equation [1]^a
 - (1a) $\eta = 0.002207 - 1.95/T$ for Saybolt time less than 100 sec
 - (1b) $\eta = 0.002207 - 1.35/T$ for Saybolt time greater than 100 sec
- (2) Saybolt Furol—Garner and Kelly equation [10]
 - (2a) $\eta = 0.02347 - 1.84/T$ from 25 to 40 sec.
 - (2b) $\eta = 0.02167 - 0.6/T$ above 40 sec
- (3) Redwood No 1—Garner and Kelly [10]
 - (3a) $\eta = 0.002607 - 1.79/T$ from 34 to 100 sec
 - (3b) $\eta = 0.002477 - 0.5/T$ above 100 sec
- (4) Redwood No 2—Garner and Kelly [10]
 - (4a) $\eta = 0.024587 - 1.0/T$ from 32.5 to 90 sec
 - (4b) $\eta = 0.024477$ above 90 sec
- (5) Engler [10]
 - (5a) $\eta = 0.08 \times E^* - 0.0664/E$ for F between 1.35 and 3.2
 - (5b) $\eta = 0.076 \times E - 0.04/E$ for E above 3.2

^a At the time of going to press the A S T M is publishing for information (see report of committee D 2, 1936 A S T M proceedings) a proposed new revision from kinematic viscosity to Saybolt viscosities as given in Table IV. The relationship differs somewhat from that given by the equation referred to above and is offered in lieu of the latter. It will be advisable to consult the latest A S T M treatment of this subject.

Dimensions of Saybolt Oil Tubes [5]

Dimensions	Saybolt Universal viscometer			Saybolt Furol viscometer		
	Min cm	Norm cm	Max cm	Min cm	Norm cm	Max cm
Inside diameter of outlet tube	0.1750	0.1765	0.1780	0.313	0.315	0.317
Outside diameter of outlet tube at lower end	0.28	0.30	0.32	0.40	0.41	0.46
Length of outlet tube*	1.215	1.225	1.235	1.215	1.225	1.235
Height of overflow rim above bottom of outlet tube*	12.40	12.50	12.60	12.40	12.50	12.60
Outside diameter of overflow rim at the top*	†	†	3.30	‡		3.30
Diameter of container*	2.955	2.975	2.995	2.955	2.975	2.995
Depth of cylindrical part of container	8.8			8.8		
Diameter of container between bottom of cylindrical part of container and top of outlet tube*	0.9			0.9		

* The dimension is identical in the Saybolt Universal and the Saybolt Furol instruments.
 † The section of overflow rim shall be bounded by straight lines except that a fillet is permissible at the junction with the bottom of the gallery.
 ‡ The minimum value shall preferably be not less than 3.2 cm.

Dimensions of Redwood Instruments [5]

Dimension	Redwood No 1		Redwood No 2	
	mm	Tolerance	mm	Tolerance
Internal diameter of oil cup	46.5	±0.5	46.5	±0.5
Vertical distance from rim to top of bore	96.0	±1.0	96.0	±1.0
Height of cylindrical portion of oil cup	86.0	±1.0	86.0	±1.0
Height of filling point above upper end of bore	82.5	±2.0	85.0	±2.0
Internal length of jet	10.0	±0.05	50.0	±0.2
Minimum internal diameter of jet	1.620		1.80	
External diameter of jet			10.0	
			approx	

Standard Dimensions of Engler Viscometer [5]

Specified distances	Normal dimensions	
	cm	Tolerance
Length of outlet tube	2.0	±0.01
Inside diameter of outlet tube at upper end	0.29	±0.002
Inside diameter of outlet tube at lower end	0.28	±0.002
Outside diam eter of outlet tube	0.45	±0.02
Length of outlet tube projecting below bottom of bath	0.30	±0.03
Inside diameter of container	10.6	±0.10
Depth of cylindrical part of container below the gauge points	2.5	±0.10
Height of the gauge points above lower end of out let tube	5.2	±0.05

For certain purposes it is more convenient to employ conversion charts, but where a high degree of accuracy is desired the values given in Table IV should be used. In preparing this table all values have been carried to one place beyond that justified by the precision of single observations on commercial instruments. The last figure should be disregarded except when group averages justify the implied precision. All intervals have been chosen to make possible reasonably accurate interpolation.

The National Bureau of Standards [20] has a series of oils available for use as viscosity standards. At 25° C the oils available at present cover the range of from 0.25 poise to 31 poises or from 0.28 stoke to 34 Stokes. The viscosities of these oils can be supplied at other temperatures when requested. Samples of these oils are also available for checking the accuracy of Saybolt viscometers. These oils are not to be considered as permanent viscosity standards, but as a means of effecting a comparison between the instruments of the National Bureau of Standards and instruments in laboratories elsewhere, which it is desired to calibrate. The charge for 1-quart samples of these oils with the viscosity given at one temperature is \$10, \$11, or \$7.50 per sample according to whether absolute, kinematic, or Saybolt viscosity is required.

A.P.I.—Committee on Viscosity Standards (1932) [2]

The American Petroleum Institute Committee on Viscosity Standards was created in 1922 for the purpose of co operating with the Bureau of Standards in establishing standard Saybolt tubes and procedure. In 1930 the committee prepared large samples of two oils, one known as Alpha oil, which is a secondary reference standard for viscosities at 100° F Universal, and a second, known as Beta oil, which serves the dual purpose of a 210° F Saybolt Universal and 122° F Saybolt Furol secondary standard Viscosity values as determined by the A P I Committee were

- Alpha oil at 100° F = 295.0 sec ± 0.3 %
- Beta oil at 210° F = 148.5 sec ± 0.3 %
- and the Saybolt Furol viscosity
- Beta oil at 122° F = 116.0 sec ± 0.3 %

TABLE IV
Viscometer Conversion Tables

Centistokes	Saybolt Universal seconds		Saybolt Furol	Redwood No 1 seconds			Redwood No 2	Engler degrees	Centistokes	Saybolt Universal seconds		Saybolt Furol	Redwood No 1 seconds			Redwood No 2	Engler degrees
	100°F	210°F		70°F	140°F	300°F				100°F	210°F		82.9	143.6	300.0		
*30	35.0	36.3							19.4	95.0	96.0		82.9	83.6	84.6	2.81	
32	36.5	36.9							19.6	95.9	96.9		83.6	84.3	85.3	2.83	
34	37.1	37.5							19.8	96.7	97.7		84.3	85.0	86.1	2.85	
*36	37.7	38.2							*120.0	97.6	98.6		85.0	85.7	86.8	2.88	
38	38.4	38.8							20.2	98.4	99.5		85.8	86.5	87.6	2.90	
40	39.0	39.4		35.3	35.9	36.3		1.32	20.4	99.2	100.3		86.5	87.2	88.4	2.92	
42	39.6	40.0		35.8	36.4	36.8		1.34	20.6	100.1	101.1		87.2	88.0	89.1	2.95	
44	40.2	40.7		36.3	36.9	37.3		1.35	20.8	100.9	102.0		87.9	88.7	89.9	2.97	
46	40.8	41.3		36.8	37.4	37.9		1.37	*121.0	101.8	102.9		88.7	89.5	90.7	2.99	
48	41.5	41.9		37.4	37.9	38.4		1.38	21.2	102.6	103.7		89.4	90.2	91.4	3.01	
*50	42.2	42.6		37.9	38.4	38.9		1.40	21.4	103.5	104.5		90.1	91.0	92.2	3.03	
52	42.8	43.2		38.4	38.9	39.4		1.42	21.6	104.3	105.4		90.9	91.7	93.0	3.05	
54	43.5	43.9		39.0	39.4	39.9		1.43	21.8	105.2	106.3		91.6	92.5	93.7	3.08	
56	44.1	44.5		39.5	40.0	40.4		1.45	*122.0	106.1	107.1		92.4	93.2	94.5	3.10	
58	44.7	45.2		40.0	40.5	41.1		1.46	22.2	106.9	107.9		93.1	94.0	95.3	3.12	
*60	45.4	45.8		40.5	41.1	41.5		1.48	22.4	107.8	108.8		93.9	94.8	96.0	3.14	
62	45.9	46.5		41.1	41.6	42.1		1.49	22.6	108.7	109.7		94.6	95.6	96.8	3.17	
64	46.6	47.1		41.6	42.2	42.6		1.51	22.8	109.5	110.5		95.4	96.3	97.6	3.19	
66	47.2	47.7		42.2	42.6	43.2		1.53	*123.0	110.4	111.4		96.1	97.1	98.3	3.21	
68	47.9	48.4		42.7	43.1	43.7		1.55	23.2	111.2	112.3		96.9	97.8	99.1	3.23	
*70	48.6	49.1		43.2	43.7	44.2		1.57	23.4	112.1	113.1		97.6	98.6	99.9	3.25	
72	49.2	49.7		43.8	44.2	44.7		1.59	23.6	113.0	114.0		98.4	99.4	100.7	3.27	
74	49.8	50.4		44.3	44.7	45.3		1.60	23.8	113.9	114.9		99.1	100.1	101.5	3.29	
76	50.5	51.1		44.9	45.3	45.8		1.62	*124.0	114.7	115.8		99.9	100.9	102.2	3.32	
78	51.1	51.7		45.5	45.8	46.4		1.64	24.2	115.6	116.6		100.7	101.7	103.0	3.34	
*80	51.9	52.4		46.0	46.3	46.9		1.65	24.4	116.5	117.5		101.4	102.4	103.7	3.37	
82	52.5	53.1		46.6	46.9	47.4		1.67	24.6	117.3	118.4		102.1	103.2	104.5	3.40	
84	53.2	53.8		47.1	47.4	48.0		1.69	24.8	118.2	119.3		102.9	103.9	105.3	3.42	
86	54.0	54.6		47.7	48.0	48.5		1.71	*125.0	119.1	120.2		103.7	104.7	106.1	3.45	
88	54.7	55.1		48.2	48.5	49.1		1.73	25.2	119.9	121.0		104.5	105.6	106.9	3.47	
*90	55.3	55.8		48.8	49.1	49.7		1.76	25.4	120.8	121.9		105.3	106.2	107.7	3.49	
92	56.0	56.5		49.4	49.6	50.2		1.78	25.7	121.7	122.8		106.1	107.1	108.5	3.52	
94	56.7	57.1		49.9	50.2	50.8		1.78	25.8	122.5	123.7		106.8	107.8	109.3	3.55	
96	57.4	57.8		50.5	50.8	51.4		1.80	126.0	123.4	124.5		107.5	108.6	110.0	3.57	
98	58.1	58.5		51.1	51.4	52.0		1.82	26.2	124.2	125.5		108.3	109.3	110.8	3.60	
*100	58.8	59.3		51.7	52.0	52.6		1.84	26.4	125.1	126.4		109.1	110.1	111.6	3.62	
102	59.5	60.0		52.3	52.6	53.2		1.86	26.6	126.0	127.2		109.9	110.9	112.4	3.65	
104	60.2	60.7		52.9	53.2	53.8		1.88	26.8	126.9	128.1		110.7	111.7	113.2	3.67	
106	60.9	61.4		53.5	53.8	54.5		1.90	*127.0	127.8	128.9		111.4	112.4	114.0	3.70	
108	61.6	62.1		54.1	54.4	55.0		1.92	27.2	128.6	129.9		112.2	113.3	114.8	3.72	
*110	62.3	62.8		54.7	55.0	55.6		1.93	27.4	129.5	130.8		113.0	114.1	115.6	3.75	
112	63.0	63.5		55.4	55.8	56.2		1.95	27.6	130.4	131.7		113.8	114.9	116.4	3.77	
114	63.7	64.3		56.0	56.2	56.9		1.97	27.8	131.3	132.6		114.6	115.7	117.2	3.79	
116	64.4	65.0		56.6	56.9	57.5		1.99	*128.0	132.2	133.5		115.3	116.5	118.0	3.82	
118	65.2	65.8		57.3	57.5	58.1		2.01	28.2	133.0	134.4		116.1	117.3	118.8	3.84	
*120	65.9	66.5		57.8	58.1	58.8		2.03	28.4	133.9	135.2		116.9	118.1	119.6	3.87	
122	66.6	67.2		58.6	58.8	59.4		2.05	28.6	134.8	136.1		117.7	118.8	120.4	3.90	
124	67.4	68.0		59.2	59.4	60.1		2.07	28.8	135.6	137.0		118.4	119.6	121.2	3.92	
126	68.1	68.8		59.8	60.0	60.7		2.09	*129.0	136.5	137.9		119.2	120.4	122.0	3.95	
128	68.9	69.5		60.5	60.7	61.3		2.11	29.2	137.4	138.7		120.0	121.2	122.8	3.97	
*130	69.7	70.3		61.1	61.3	61.9		2.13	29.4	138.3	139.7		120.8	122.0	123.6	4.00	
132	70.5	71.1		61.7	62.0	62.6		2.15	29.6	139.2	140.6		121.5	122.8	124.4	4.03	
134	71.1	71.7		62.3	62.6	63.2		2.17	29.8	140.1	141.5		122.3	123.6	125.2	4.05	
136	71.9	72.6		63.0	63.3	63.9		2.19	*130.0	141.0	142.4		123.1	124.4	126.0	4.08	
138	72.7	73.4		63.7	63.9	64.6		2.21	30.2	141.9	143.2		123.9	125.1	126.9	4.10	
*140	73.5	74.2		64.3	64.5	65.2		2.23	30.4	142.7	144.1		124.6	125.9	127.7	4.13	
142	74.2	74.9		65.0	65.2	65.9		2.25	30.6	143.6	145.0		125.4	126.7	128.5	4.15	
144	75.0	75.7		65.6	65.9	66.6		2.27	30.8	144.5	146.0		126.2	127.5	129.3	4.18	
146	75.7	76.5		66.3	66.6	67.3		2.30	*131.0	145.4	146.9		127.0	128.3	130.1	4.21	
148	76.5	77.2		66.9	67.3	68.0		2.32	31.2	146.3	147.8		127.8	129.1	130.9	4.23	
*150	77.3	78.0		67.7	68.0	68.7		2.34	31.4	147.2	148.8		128.6	129.9	131.7	4.26	
152	78.0	78.8		68.3	68.6	69.3		2.36	31.6	148.1	149.7		129.4	130.7	132.5	4.28	
154	78.8	79.6		69.0	69.3	70.0		2.38	31.8	149.0	150.6		130.2	131.5	133.3	4.31	
156	79.4	80.4		69.7	70.0	70.7		2.40	*132.0	149.9	151.5		131.0	132.3	134.1	4.34	
158	80.4	81.2		70.3	70.7	71.5		2.42	32.2	150.7	152.4		131.8	133.1	134.9	4.36	
160	81.2	82.0		71.0	71.4	72.2		2.44	32.4	151.6	153.3		132.6	133.9	135.7	4.39	
*162	82.0	82.8		71.7	72.1	72.9		2.46	32.6	152.5	154.2		133.4	134.7	136.5	4.41	
164	82.8	83.6		72.4	72.8	73.6		2.48	32.8	153.4	155.2		134.2	135.5	137.3	4.44	
166	83.6	84.5		73.1	73.5	74.3		2.50	*133.0	154.4	156.0		135.0	136.3	138.1	4.46	
168	84.4	85.3		73.8	74.2	75.0		2.53	33.2	155.2	157.0		135.7	137.1	138.9	4.49	
*170	85.2	86.1		74.4	74.9	75.8		2.55	33.4	156.1	157.9		136.5	137.9	139.7	4.51	
172	86.0	86.9		75.1	75.6	76.5		2.57	33.6	157.0	158.8		137.3	138.7	140.5	4.54	
174	86.8	87.7		75.8	76.3	77.2		2.59	33.8	157.9	159.7		138.1	139.5	141.4	4.56	
176	87.6	88.5		76.5	77.0	77.9		2.61	*134.0	158.9	160.5		138.9	140.2	142.2	4.59	
178	88.4	89.4		77.2	77.7	78.6		2.63	34.2	159.7	161.5		139.7	141.0	143.0	4.62	
*180	89.3	90.2		77.9	78.4	79.2		2.66	34.4	160.6	162.4		140.5	141.8	143.8	4.64	
182	90.0	91.0		78.6	79.2	80.1		2.68	34.6	161.5	163.3		141.3	142.6	144.6	4.67	
184	90.9	91.9		79.3	79.9	80.8		2.70	*135.0	162.4	164.2		142.1	143.4	145.4	4.69	
186	91.7	92.7		80.0	80.7	81.5		2.72	34.8	163.3	165.1		142.9	144.2	146.2	4.72	
188	92.5	93.5		80.7	81.4	82.3		2.74	35.2	164.2	166.0		143.7	145.0	147.0	4.75	
*190	94.0	95.2		81.4	82.1	83.1		2.77	35.4	165.1	167.0		144.5	145.8	147.8	4.77	
192	94.2	95.5		82.1	82.9	83.8		2.79	35.6	165.9	167.8		145.3	146.6	148.6	4.80	

* Values noted are quoted from A S T M Committee D 2 tables (1936) Others are

VISCOSITY CHARACTERISTICS OF PETROLEUM PRODUCTS AND THEIR DETERMINATION 1077

TABLE IV (cont)

Centistokes	Saybolt Universal seconds		Saybolt Furol	Redwood No 1 seconds			Red wood No 2	Engler degrees	Centistokes	Saybolt Universal seconds		Saybolt Furol	Redwood No 1 second			Red wood No 2	Engler degrees
	100 F	210 F		70 F	140 F	200 F				100 F	210 F		70 F	140 F	200 F		
35.8	166.8	168.7		146.1	147.4	149.4		4.82	63	290.6	293.8	30.8	255.5	257.5	262.5	8.29	
*36.0	167.7	169.6		146.2	147.5	149.5		4.85	64	295.2	298.5	31.2	258.5	260.5	265.5	8.43	
36.2	168.6	170.5		146.3	147.6	151.0		4.88	65	299.8	303.2	31.8	263.1	265.5	270.5	8.56	
36.4	169.5	171.4		148.4	149.8	151.8		4.90	66	304.4	307.8	32.0	267.5	270.0	275.0	8.69	
36.6	170.4	172.4		149.2	150.6	152.6		4.93	67	309.0	312.4	32.5	271.5	274.0	279.0	8.82	
36.8	171.3	173.3		150.1	151.4	153.4		4.98	68	313.6	317.0	33.0	275.5	278.0	283.0	8.96	
*37.0	172.3	174.2		150.9	152.2	154.2		4.98	69	318.2	321.5	33.3	279.5	282.0	287.5	9.08	
37.2	173.1	175.1		151.7	153.0	155.0		5.00	*70	322.7	326.0	33.7	284.0	286.0	291.5	9.21	
37.4	174.0	176.0		152.6	153.8	155.9		5.03	71	327.4	330.6	34.1	288.2	290.0	296	9.35	
37.6	175.0	177.0		153.4	154.6	156.7		5.05	72	332.0	335.4	34.5	292.2	294	300	9.48	
37.8	175.9	177.9		154.2	155.4	157.5		5.08	73	336.5	340.1	35.0	296.2	298	304	9.61	
38.0	176.8	178.8		155.0	156.2	158.3		5.10	74	341.1	344.8	35.4	300	302	308	9.74	
38.2	177.7	179.7		155.8	157.0	159.2		5.13	*75	345.6	349.3	35.8	304	306	311*	31.8	
38.4	178.6	180.6		156.6	157.8	160.0		5.16	76	350.7	354.0	36.2	308	311	317	32.2	
38.6	179.5	181.5		157.4	158.7	160.8		5.18	77	354.8	358.6	36.6	312	315	321	32.6	
38.8	180.4	182.4		158.2	159.5	161.6		5.21	78	359.4	363.2	37.1	316	319	325	33.0	
*39.0	181.3	183.3		159.0	160.3	162.5		5.23	79	364.0	367.8	37.5	320	323	329	33.4	
39.2	182.2	184.2		159.8	161.1	163.3		5.26	*80	368.5	372.5	37.9	324	327	333	33.8	
39.4	183.1	185.1		160.6	161.9	164.1		5.28	81	372.8	377.2	38.4	328	331	337	34.2	
39.6	184.0	186.0		161.4	162.7	164.9		5.31	82	377.4	381.8	38.8	332	335	341	34.6	
39.8	184.9	186.9		162.2	163.5	165.8		5.33	83	381.9	386.4	39.2	336	339	345	35.0	
*140.0	185.9	187.8		163.0	164.3	166.7		5.36	84	386.6	391.1	39.7	340	343	349	35.4	
40.2	186.8	188.7		163.8	165.1	167.5		5.39	85	391.5	395.8	40.1	344	347	353	35.8	
40.4	187.7	189.6		164.6	165.9	168.3		5.41	86	395.8	400.4	40.6	348	351	358	36.2	
40.6	188.7	190.6		165.4	166.7	169.1		5.44	87	400.4	405.0	41.0	352	355	362	36.6	
40.8	189.6	191.5		166.2	167.5	169.9		5.46	88	405.1	409.7	41.5	356	359	366	36.9	
*141.0	190.4	192.4		167.0	168.3	170.8		5.49	89	409.7	414.3	41.9	360	363	371	37.3	
41.2	191.3	193.3		167.8	169.1	171.6		5.52	*90	414.4	419.1	42.4	364	367	375	37.7	
41.4	192.3	194.3		168.6	169.9	172.5		5.54	91	419.0	423.7	42.8	368	371	379	38.1	
41.6	193.2	195.0		169.4	170.7	173.3		5.57	92	423.6	428.3	43.3	372	375	384	38.5	
41.8	194.1	196.0		170.2	171.5	174.2		5.60	93	428.2	433.0	43.7	376	379	388	38.9	
*142.0	195.0	197.0		171.0	172.3	175.0		5.62	94	432.8	437.6	44.2	380	383	392	39.3	
42.2	195.9	197.9		171.8	173.2	175.8		5.65	95	437.5	442.3	44.6	384	387	396	39.7	
42.4	196.8	198.8		172.6	174.0	176.7		5.67	96	442.0	447.0	45.1	388	391	400	40.1	
42.6	197.7	199.7		173.4	174.8	177.5		5.70	97	446.6	451.6	45.6	393	395	405	40.5	
42.8	198.6	200.7		174.2	175.6	178.3		5.72	98	451.2	456.4	46.0	397	399	409	40.9	
*143.0	199.5	201.6		175.1	176.4	179.2		5.73	99	455.8	461.0	46.5	401	404	413	41.3	
43.2	200.4	202.5		175.9	177.2	180.0		5.75	*100	460.4	465.6	47.0	405	408	417	41.7	
43.4	201.3	203.4		176.7	178.0	180.8		5.80	101			47.4	409	412	42.1		
43.6	202.2	204.4		177.5	178.8	181.7		5.82	102			47.8	413	416	42.5		
43.8	203.1	205.1		178.3	179.6	182.5		5.85	103			48.3	417	420	42.9		
44.0	204.0	206.2		179.1	180.4	183.3		5.88	104			48.8	421	424	43.3		
*144.0	204.9	207.1		179.9	181.3	184.2		5.90	105			49.2	425	429	43.7		
44.4	205.9	208.0		180.7	182.1	185.0		5.93	106			49.6	429	433	44.1		
44.6	206.8	209.0		181.5	182.9	185.7		5.96	107			50.1	433	437	44.5		
44.8	207.7	209.9		182.3	183.7	186.7		5.98	108			50.5	437	441	44.9		
*145.0	208.6	210.7		183.1	184.5	187.5		6.00	109			51.0	441	445	45.3		
45.2	209.5	211.7		183.9	185.3	188.3		6.02	*110			51.5	445	449	45.7		
45.4	210.4	212.6		184.8	186.1	189.2		6.03	111			51.9	449	453	46.1		
45.6	211.3	213.5		185.6	187.0	190.0		6.05	112			52.4	453	457	46.4		
45.8	212.2	214.4		186.4	187.7	190.8		6.06	113			52.8	457	461	46.8		
*146.0	213.1	215.4		187.2	188.5	191.7		6.08	114			53.3	461	466	47.2		
46.2	214.0	216.3		188.0	189.3	192.5		6.09	115			53.8	465	470	47.6		
46.4	214.9	217.2		188.8	190.2	193.4		6.11	116			54.2	470	474	48.0		
46.6	215.8	218.1		189.6	191.0	194.2		6.14	117			54.7	474	478	48.4		
46.8	216.7	219.0		190.4	191.8	195.0		6.17	118			55.1	478	482	48.8		
*147.0	217.6	219.9		191.2	192.6	195.7		6.19	119			55.6	482	486	49.2		
47.2	218.5	220.8		192.0	193.4	196.7		6.22	120			56.0	486	490	49.6		
47.4	219.4	221.7		192.8	194.2	197.5		6.24	121			56.5	490	494	50.0		
47.6	220.4	222.7		193.6	195.0	198.4		6.27	122			57.0	494	498	50.4		
47.8	221.3	223.6		194.4	195.8	199.6		6.29	123			57.4	498	502	50.8		
*148.0	222.2	224.5	24.8	195.2	196.6	200.0		6.32	124			57.9	502	506	51.2		
48.2	223.1	225.4	24.8	196.0	197.4	200.9		6.35	125			58.4	506	510	51.6		
48.4	224.0	226.3	24.8	196.8	198.3	201.7		6.37	126			58.8	510	514	52.0		
48.6	224.9	227.1	25.0	197.6	199.0	202.6		6.39	127			59.3	514	518	52.4		
48.8	225.8	228.2	25.1	198.4	199.9	203.4		6.43	128			59.7	518	523	52.8		
*149.0	226.7	229.1	25.2	199.2	200.7	204.2		6.45	129			60.2	522	527	53.3		
49.2	227.6	229.9	25.3	200.0	201.5	205.0		6.48	130			60.7	526	531	53.7		
49.4	228.5	231.0	25.3	200.8	202.3	205.8		6.51	131			61.1	530	535	54.1		
49.6	229.4	231.9	25.4	201.7	203.1	206.7		6.53	132			61.6	534	539	54.5		
49.8	230.3	232.8	25.5	202.5	203.9	207.5		6.56	133			62.1	538	543	54.9		
*150.0	231.2	233.8	25.5	203.3	204.7	208.3		6.58	134			62.5	542	547	55.3		
51.0	235.6	238.3	25.9	207.0	209.0	212.5		6.72	135			63.0	546	551	55.7		
*51.5	236.5	239.2	26.3	211.5	213.5	216.5		6.85	136			63.5	550	555	56.1		
52.0	244.8	247.5	26.7	215.0	217.0	221.0		6.98	137			63.9	554	559	56.5		
54	249.4	252.1	27.1	219.5	221.0	225.0		7.11	138			64.3	559	563	56.9		
*55	254.0	256.8	27.5	223.5	225.0	229.0		7.24	139			64.8	563	567	57.3		
56	258.6	261.4	27.9	228.0	229.0	233.0		7.40	140			65.2	567	571	57.7		
57	263.2	266.0	28.3	231.5	233.0	237.0		7.51	141			65.7	571	575	58.1		
58	267.8	270.7	28.7	235.5	237.0	241.5		7.64	142			66.2	575	579	58.5		
59	272.4	275.3	29.1	239.5	241.0	246.0		7.77	143			66.6	579	583	58.9		
*60	277.0	280.0	29.6	243.5	245.3	250.0		7.89	144			67.1	583	587	59.3		
61	281.4	284.6	30.0	247.5	249.0	254.0		8.03	145			67.5	587	591	59.7		
62	286.1	289.2	30.4	251.5	253.0	258.5		8.16	146			68.0	591	595	60.1		

* Values noted are quoted from A S T M Committee D 2 tables (1936) Others are interpolated
 † Values noted are quoted from

PHYSICAL AND CHEMICAL PROPERTIES

Cresc-stokes	Saybolt Universal seconds		Saybolt Furol	Redwood No 1 seconds			Redwood No. 2	Engler degrees	Cresc-stokes	Saybolt Universal seconds		Saybolt Furol	Redwood No 1 seconds			Redwood No. 2	Engler degree
	100°F	210°F		70°F	100°F	200°F				100°F	210°F		70°F	100°F	140°F		
147			68.4	935	599		60.5		440			203.9				179.8	
148			68.9	599	604		60.9		450			208.5				183.0	
149			69.3	603	608		61.3		460			213.7				188.0	
*150	690.6	698.4	69.8	607	612		61.7		470			218.8				192.1	
151			70.2	611	616		62.1		480			223.4				196.1	
152			70.7	615	620		62.5		490			227.0				200.2	
153			71.2	619	624		62.9		500			231.6				204.3	
154			71.6	623	628		63.3		510			236.2				208.4	
155			72.1	627	632		63.7		520			240.9				212.5	
156			72.6	632	637		64.1		530			245.5				216.5	
157			73.0	636	641		64.5		540			250.1				220.6	
158			73.5	640	645		64.9		550			254.8				224.7	
159			74.0	644	649		65.3		560			259.4				228.8	
160			74.5	648	653		65.7		570			264.0				232.9	
161			74.9	652	657		66.1		580			268.6				236.9	
162			75.4	656	661		66.5		590			273.3				241.0	
163			75.8	660	665		66.9		600			277.9				245.1	
164			76.3	664	669		67.3		610			282.5				249.2	
165			76.8	668	673		67.7		620			287.1				253.3	
166			77.2	672	677		68.1		630			291.7				257.4	
167			77.7	676	682		68.5		640			296.3				261.5	
168			78.1	680	686		68.9		650			301.0				265.6	
169			78.6	684	690		69.4		660			305.5				269.6	
170			79.1	688	694		69.8		670			310.1				273.7	
171			79.5	692	698		70.2		680			314.7				277.8	
172			80.0	696	702		70.6		690			319.3				281.9	
173			80.5	700	706		71.0		700			324.0				286.0	
174			80.9	704	710		71.4		710			328.6				290.0	
175			81.4	709	714		71.8		720			333.2				294.2	
176			81.8	713	719		72.3		730			337.8				298.3	
177			82.3	717	723		72.6		740			342.4				302.4	
178			82.3	721	727		73.0		750			347.0				306.5	
179			83.2	725	731		73.4		760			351.6				310.6	
180			83.7	729	735		73.8		770			356.2				314.7	
181			84.2	733	739		74.2		780			360.8				318.8	
182			84.6	737	743		74.6		790			365.4				322.9	
183			85.1	741	747		75.0		800			370.0				327.0	
184			85.5	745	751		75.4		810			374.7				331.1	
185			86.0	749	755		75.8		820			379.4				335.2	
186			86.5	753	760		76.2		830			384.1				339.3	
187			86.9	757	764		76.6		840			388.8				343.4	
188			87.4	761	768		77.0		850			393.5				347.5	
189			87.8	765	772		77.5		860			398.2				351.6	
190			88.3	769	776		77.9		870			402.9				355.7	
191			88.8	773	780		78.3		880			407.6				359.8	
192			89.2	777	784		78.7		890			412.3				363.9	
193			89.7	781	788		79.1		900			417.0				368.0	
194			90.1	785	792		79.5		910			421.6				372.0	
195			90.6	789	796		79.9		920			426.2				376.1	
196			91.1	794	800		80.3		930			430.8				380.2	
197			91.5	798	804		80.7		940			435.4				384.2	
198			92.0	802	808		81.1		950			440.0				388.3	
199			92.4	806	812		81.5		960			444.6				392.3	
*200	920.6	931.2	92.9	810	816		81.9		970			449.2				396.4	
1210			97.5	850	857		85.9		980			453.8				400.4	
2220			102.1	891	898		90.0		990			458.4				404.5	
2300			104.8	931	939		94.1		1,000			463.0				408.5	
2340			111.4	972	980		98.1		1,100			509.7				454.0	
2350			116.0	1,012	1,021		102.2		1,200			556.6				490.0	
2360			120.6	1,053			106.2		1,300			603.1				531.0	
2270			125.2	1,093			110.3		1,400			649.8				572.0	
2280			129.9	1,134			114.4		1,500			696.5				613.0	
2290			134.5	1,174			118.4		1,600			743.2				654.0	
1900			139.1	1,215			122.5		1,700			789.9					
1310			143.7	1,255			126.6		1,800			836.6					
1320			148.4	1,296			130.7		1,900			883.3					
1330			153.0	1,336			134.8		2,000			930.0					
1340			157.6	1,377			138.9		2,100			976.7					
1350			162.3	1,417			143.0		2,200			1,023.4					
1360			166.9				147.1		2,300			1,070.0					
370			171.5				151.2		2,400			1,116.8					
380			176.1				155.3		2,500			1,163.5					
390			180.6				159.4		2,600			1,210.0					
400			185.4				163.5		2,700			1,257.0					
410			190.0				167.5		2,800			1,304.0					
420			194.6				171.6		2,900			1,350.0					
430			199.2				175.7										

For Redwood times above 1,400 sec at 70° F., Redwood sec at 400 X C.

Use equation (4) for conversions above this point.

* Values noted are quoted from I P T Standardization Committee tables Others are interpolated

† Values noted are quoted from A S T M Committee D 2 tables (1936) Others are interpolated

The samples were prepared very carefully and are examined at periodic intervals for variation in physical and chemical properties which might indicate change in viscosity with time. The committee has made the oils available to the industry so as to promote standardization of viscosity measurements. They may be procured from the Chairman of the A P I Committee, Dr. T. G. Delbridge, 3144 Passyunk Avenue, Philadelphia, Pa. The charge is \$5 per quart.

Standards for Instrument Calibration, recommended by the A P I are as follows:

- (1) Water [10] Probably fundamentally the best. Accurate to 0.4%.
- (2) Bureau of Standard Oils—A series of oils calibrated on a Bingham viscometer covering a range of 28 to 3,400 centistokes at 100° F. [24]
- (3) American Petroleum Institute Alpha and Beta Oils

Other standards used, but not recommended:

- (1) Sucrose [14] Hygroscopic and liable to fermentation
- (2) Castor Oil [15] Gives variations as high as 2.5%

t° C	5	10	15	20	25	30	35	40
η (poises)	37.60	24.18	15.14	9.86	6.51	4.51	3.16	2.31

Variation of Viscosity with Temperature

A number of individual attempts have been made to produce a chart which accurately expresses the variation of viscosity with change in temperature. The one most widely used at the present time is that based on the original of MacCoull and known as the A S T M Tentative Standard

D 341-32 T, which was issued in 1932 by the American Society for Testing Materials. Large-scale reproductions of this chart are obtainable from the A S T M, but it is not reproduced here because it is useless on a small scale. It is based upon a modification of Vogel's equation, which may be expressed as follows:

$$\log \log(100\nu + 0.8) = a + b \log T,$$

where 100ν = kinematic viscosity in centistokes,

T = absolute temperature, degrees Rankine,

a and b are constants

In using this chart it is only necessary to plot viscosities at any two temperatures and draw a straight line through the points. The viscosity is taken at any desired temperature from the line and may be read either in Saybolt Universal or as Kinematic Viscosity in centistokes. The chart is not strictly accurate for viscosities below 60 sec Saybolt Universal. Obviously data cannot be extended by means of the chart through phase changes (wax, separation, evaporation, thermal decomposition, &c.) without exercising the necessary consideration. See article [23]. A similar chart due to FitzSimons in which the basic A S T M equation has been altered to read

$$\log \log(100\nu + 0.89) = a + b \log T$$

has been found to give excellent results when used to correlate viscosity-temperature data of light products, and is useful down to a viscosity of 0.16 centistokes.

The relationship between viscosity and temperature for hydrocarbons and petroleum products and its representation by the viscosity index and similar functions are discussed elsewhere in articles by Docksey [25] and Wiggins [28].

REFERENCES

- 1 A S T M D 341-32 T
- 2 A S T M Committee on Viscosity Standards (1932)
- 3 ARVSON, M. H. *Ind Eng Chem* 24, 71 (1932), 26, 628 (1934)
- 4 BARR. *A Monograph of Viscosity*, chap. 2 (1931)
- 5 ——. *A Monograph of Viscosity*, Appendix I
- 6 BINGHAM and WHITE. *Z. phys. Chem.* 80, 670 (1912)
- 7 B E S A no 188 (1929)
- 8 DORSEY. *International Critical Tables*, 5. Water at 10° C = 1.309 centipoise
- 9 FITZSIMONS, O. *Ind Eng Chem, Anal Ed* 7, 345 (1935)
- 10 GARNER, F. H. and KILLY, C. J. *Physics*, 4 (1933)
- 11 GRUNEBEN, E. *Wiss. Abhandl. physik. tech. Reichsanstalt*, 4, 166 (1905)
- 12 HÖPPLER, F. *Proc. World Petr. Congr.*, part II, 503 (1933)
- 13 *International Critical Tables*, 1, 33
- 14 *International Critical Tables*, 5, 23
- 15 KARHLMUND and RÄBER. *Abh. Kaiser Leop. Carol. deutsche Akad. Naturf.* 84, 203 (1905)
- 16 LAMB, H. *Hydrodynamics*, 5th ed., 532 et seq.
- 17 McCULLER, W. B., and FENSKE, M. R. *Ind Eng Chem* 27, 82 (1935)
- 18 POISSUILLF. *Compt. rend.* 11, 961, 1041, (1840)
- 19 UBBELOHDE. *J. I. P. T.* 19, 376 (1933)
- 20 U. S. BUREAU OF STANDARDS
- 21 WELLMINGANZ, E. A. *Physics* 6, 61 (1935)
- 22 WELLMINGANZ, E. A., McCULLER, W. B., FENSKE, M. R., and McGREW, R. V. *Ind Eng Chem, Anal Ed* 6, 231 (1934)

ARTICLES IN "SCIENCE OF PETROLEUM"

- 23 BEALE. The Flow of Waxy Oils and other Non-Newtonian Liquids
- 24 BEALE and DOCKSEY. The Laws of Fluid Flow in Pipes
- 25 DOCKSEY. Viscosity Index and Viscosity Gravity Constant
- 26 LAWRENCE. Anomalous Viscosity
- 27 DE WAELE. The Measurement of Plasticity
- 28 WIGGINS. Viscosity-Temperature Characteristics of Petroleum Products

VISCOSITY OF GASES

By E. S. L. BEALE, M.A., F Inst.P.

Consultant in Engineering Physics, London

DATA on the viscosity of gases is required in the calculation of the pressure drop in pipes, &c., primarily in the estimation of the Reynolds number. The Reynolds number is also required in connexion with the measurement of flow by orifice meter. This property also enters into heat-transfer equations both directly and also very often indirectly, since it is often the means of calculating the thermal conductivity of a gas in the absence of accurate experimental data.

The unit of absolute viscosity on the c g s system is the Poise, subdivided into Centipoise, Millipoise, &c., and these are the units usually employed. In order to convert absolute viscosity in c g s units into absolute viscosity in F P S units, multiply by 0.0672.

The absolute viscosity of a gas is the property which is always measured experimentally. The viscosity data taken from the *International Critical Tables* and extrapolated by Sutherland's formula, namely, $\eta = \frac{KT^1}{T+C}$ [4, 1893], is shown plotted against temperature at atmospheric pressure on Fig 1. Tabulated data from the same source, together

called the Stokes, subdivided into Centistokes, &c. To convert c g s units of kinematic viscosity to F P S units multiply by 0.0010764.

TABLE I
Absolute Viscosity in Micropoise

Temp °C	10 ⁶ × absolute viscosity in c g s units (poise)										
	Ar	N ₂	O ₂	CO	CO ₂	H ₂	CH ₄	C ₂ H ₆	C ₃ H ₈	C ₄ H ₁₀	Steam
K 10 °C	124	110	131	102	240	72	198				226
	150	143	176	135	158	66					106
0	170	168	196	162	139	86	102	87	96		88
100	218	213	232	205	186	107	131	114	127		110
200	270	252	300	241	228	125	163	140	156		167
300	295	287	343	274	267	141	187	164	182		203
400	329	319	382	304	302	155	212	188	206		238
500	359	348	418	311	315	168	233	210	228		272
600	388	375	452	317	366	180	256	230	249		305
700	415	401	484	311	395	192	275	249	268		336
800	440	425	514	404	423	203	295	267	287		367
900	464	448	542	425	449	213	312	283	304		397
1000	488	470	569	446	474	223	330	299	321		426

Since the absolute viscosity is approximately independent of pressure, the kinematic viscosity of a gas is inversely proportional to its absolute pressure. All kinematic viscosities in this article refer to atmospheric pressure, and therefore to obtain the value at any other pressure divide by the absolute pressure in atmospheres.

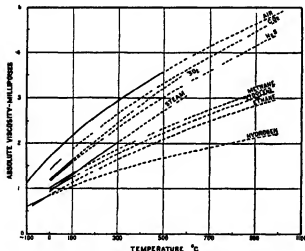

Fig 1 Absolute viscosity of gases at atmospheric pressure

with the constants in Sutherland's formula, is given in Table I taken from *Technical Data on Fuel* [3, 1935].

At pressures in the neighbourhood of atmospheric pressure the absolute viscosity of gases is independent of pressure, but at high pressures the viscosity increases with pressure. For example, the viscosity of nitrogen at 1,000 atm is about 2½ times that at atmospheric pressure [2, 1931].

The kinematic viscosity of gases is required for the calculation of the Reynolds number in pipe flow and heat-transfer calculations and is derived from the absolute viscosity data by dividing by the density. The units of density must, of course, conform to the units used for the absolute viscosity, i.e. divide by grammes per cu cm for c g s units of viscosity, or by lb per cu ft in F P S. units. The unit of kinematic viscosity on the c g s system is

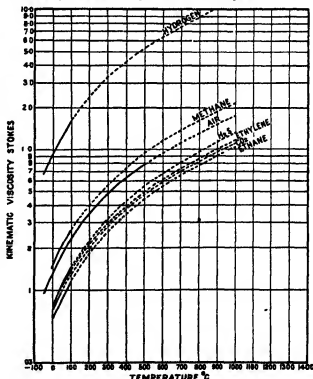

Fig 2 Kinematic viscosity of gases

Data corresponding to that given on Fig 1 and in Table I are shown on Fig 2 and in Table II (taken from *Technical Data on Fuel* [3, 1935]), all at atmospheric pressure.

The kinematic viscosity of SO₂ gas at atmospheric pressure is approximately 0.041 stokes at 0° C and 0.078 stokes at 100° C

It is frequently necessary to use a figure for the viscosity of hydrocarbon gases and vapours in heat-flow calculations

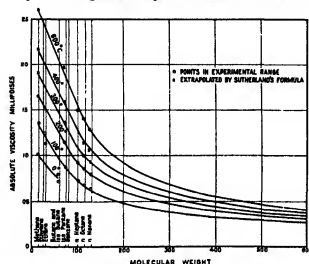

FIG 3 Absolute viscosity of hydrocarbon vapours at atmospheric pressure

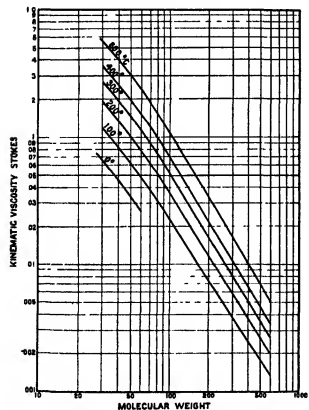

FIG 4 Kinematic viscosity of vapours molecular weight hydrocarbons (at atmospheric pressure)

in cases where no experimental data exist, and in such circumstances an approximate figure is of value, even though it may not be very accurate. The following figures have been drawn up to meet such a need.

Figs 3 and 4 for hydrocarbon vapours at atmospheric pressure were drawn from the results on hydrocarbons given in the *International Critical Tables* (up to benzene)

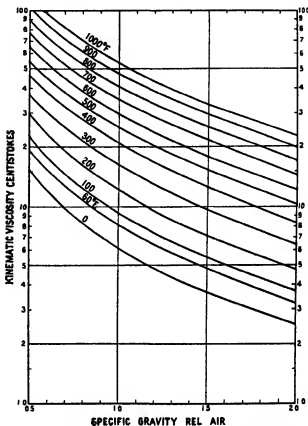

FIG 5 Kinematic viscosity at 1 atm Hydrocarbon gases

and by Melaven and Mack [1, 1932] for *n*-heptane, *n*-octane, and *n*-nonane. The results were extrapolated to 600° C by Sutherland's formula. The results were then plotted on log-log paper giving a graph showing absolute viscosity at constant temperature against molecular

TABLE II
Kinematic Viscosity in Stokes at 1 Atmosphere

Temp. °C	Air	N ₂	O ₂	CO	CO ₂	H ₂	CH ₄	C ₂ H ₆	C ₃ H ₈	Steam
0	0.131	0.134	0.137	0.129	0.071	0.955	0.143	0.065	0.077	0.109
100	0.231	0.233	0.241	0.224	0.129	1.626	0.254	0.116	0.139	0.221
200	0.346	0.349	0.364	0.334	0.202	2.41	0.395	0.181	0.216	0.360
300	0.480	0.483	0.504	0.460	0.286	3.30	0.569	0.256	0.306	0.531
400	0.628	0.631	0.660	0.601	0.380	4.24	0.731	0.345	0.406	0.730
500	0.787	0.789	0.830	0.751	0.484	5.29	0.921	0.443	0.517	0.959
600	0.960	0.962	1.012	0.916	0.596	6.41	1.14	0.548	0.657	1.21
700	1.146	1.146	1.210	1.088	0.718	7.62	1.37	0.660	0.786	1.49
800	1.341	1.337	1.416	1.270	0.846	8.87	1.62	0.779	0.902	1.80
900	1.550	1.545	1.632	1.465	0.985	10.19	1.88	0.908	1.043	2.12
1 000	1.761	1.754	1.859	1.664	1.139	11.55	2.17	1.04	1.198	2.46

weight. The constant temperature lines were found to be straight from *n*-pentane to *n*-nonane, and were extrapolated as straight lines to the higher molecular weights. These constant temperature lines were then redrawn on a uniform scale and are shown on Fig. 3. Fig. 4 gives the corresponding kinematic viscosities assuming the gas laws to

apply The same data are shown plotted against the specific gravity of the hydrocarbon gas relative to air in Fig 5 These lines for various temperatures were obtained by drawing smooth curves through points representing individual hydrocarbons and is useful for estimating the viscosity of refinery tail gases, natural gas, &c, from the

specific gravity if they are known to consist primarily of hydrocarbons

It should be noted that the viscosities of a mixture of gases cannot be calculated accurately from the percentage composition, particularly in the case of gases of widely differing types [5]

REFERENCES

- 1 MELAVEN and MACK *J A C S* 54, 888 (1932)
- 2 MICHELS, A, and GIBSON, R O *Proc Roy Soc, A*, 134, 288 (1931)
- 3 SPIERS, H M *Technical Data on Fuel*, 4th ed., 54, 55 (1935)
- 4 SUTHERLAND, W *Phil Mag* 8 35 105 (1893)
- 5 *International Critical Tables*, 5.

VISCOSITY-TEMPERATURE CHARACTERISTICS OF PETROLEUM PRODUCTS

By W. R. WIGGINS, Ph D

Department of Oil Engineering and Refining, University of Birmingham, England

The constitution of a hydrocarbon is reflected to a varying degree by its physical properties, density, boiling-point, viscosity, and temperature coefficient of viscosity are not entirely additive, but depend to a considerable extent on chemical structure. Aliphatic chains, branching, unsaturation, aromatic and naphthenic rings play characteristic roles in determining the physical properties of hydrocarbons. In addition to the chemical constitution, the physical constitution or state of aggregation of a fluid affects its viscosity-temperature relationship profoundly. The viscosity of a gas increases with temperature rise, but that of a liquid falls rapidly, the viscosity of a gas is also independent of density. Consideration of the internal energy of a fluid and the inter-molecular forces involved explains these apparent discrepancies. An analysis of the effect of the physical constitution of a fluid upon its viscosity is given by Lewis and Squires [18, 1934]. They state that the viscosity is a measure of molecular energy degradation and proceed to show that the viscosity of a liquid is far greater than that of a gas, because in the latter the energy degenerated by molecular attractions is negligible, while in the former it is preponderant. The viscosity of a liquid decreases with temperature rise, because expansion reduces the inter-molecular attractions and the friction losses induced by these collisions. The viscosity of a gas increases with rise of temperature because the velocity of the molecules is increased, resulting in more frequent collisions and increased energy dissipation.

The Influence of Chemical Constitution on the Viscosity-Temperature Relationships of Hydrocarbons.

Hugel [14, 1931] observed that, with oils having the same viscosity at a low temperature, the oil that showed the best viscosity-temperature stability (i.e. the oil with the highest viscosity at a higher temperature) was that having the greatest molecular weight, and he states that molecular volume is of greater importance than molecular weight. It seems probable, however, that molecular surface, free space, stereochemical structure, and molecular association are essential factors in determining the viscosity-temperature stability.

Paraffin Hydrocarbons. The viscosity-temperature curves for the normal paraffins are approximately parallel (Fig 1), the gradient, however, at any single temperature depending upon the molecular weight. Single branching, which lowers the viscosity slightly, does not affect noticeably the gradient of the viscosity-temperature curve, as shown by the curves for the isoparaffins which are closely parallel to those of the normal paraffins. The presence of two-branch chains in the molecule raises the viscosity, and at the same time causes an appreciable increase in the gradient of the curve (Fig 1). Disopropyl and 2,2-dimethylbutane show greater changes of viscosity for a given temperature change than *n*-hexane.

Three-branch chains in the molecule, as in 2,2,3-trimethylbutane, cause an even greater increase in viscosity and increase in the gradient of the viscosity-temperature curve.

When the logarithm of the viscosity is plotted against

temperature (in ordinary units), the curves obtained approximate to a straight-line relationship, the linear deviation being greater with the higher molecular weights. On Figs 1 and 2 are plotted the viscosity-temperature curves of various paraffins.

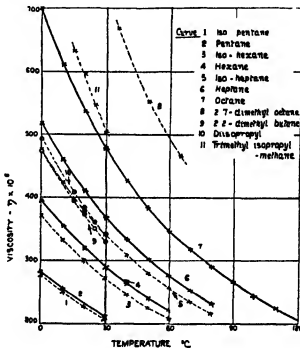

FIG 1

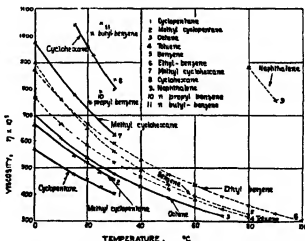

FIG 2

In general, it may be stated that viscosity-temperature stability increases with chain-length, and for isomers decreases with increased branching. This is supported by

the investigations of Sullivan, Voorhees, Neeley, and Shankland [30, 1931], on the polymerization of olefines, and by the work of Yamaguchi [37, 1934] on the temperature coefficient of viscosity and the association of high molecular weight liquids

Cyclic Hydrocarbons. The curve for benzene is steeper than the curves for the paraffin hydrocarbons. Higher homologues of the aromatic series show less steep viscosity gradients, those for toluene and ethylbenzene being approximately parallel to the curves for the normal paraffins

Cyclohexane also has a steep curve similar to that for

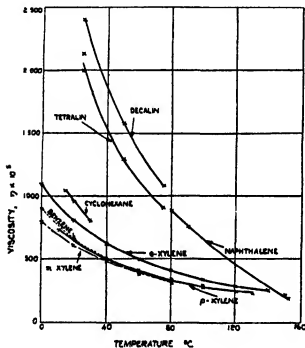

FIG 3

benzene, and it will be seen from Fig 2 that the curve for methylcyclohexane is approximately parallel to that for

toluene. Cyclopentane and methylcyclopentane have viscosity-temperature curves which are parallel to those of the normal paraffins. Naphthalene and its hydrogenated derivatives, tetrahydronaphthalene and decahydronaphthalene, exhibit a high rate of change of viscosity with temperature, much more so than benzene. This is illustrated by Fig 3

Influence of Unsaturation on Viscosity-Temperature Relationships.

In the case of aliphatic hydrocarbons, unsaturation does not affect the viscosity-temperature stability so far as is known. The unsaturated hydrocarbons 2-methyl- Δ^2 -butene, isoprene, and diallyl have viscosity-temperature curves similar to the corresponding paraffins, isopentane and hexane.

Again, with the cyclic hydrocarbons, unsaturation has little effect on the rates of change of viscosity with temperature, the curves for the aromatics resembling those of the naphthenes. With the polycyclic hydrocarbons, unsaturation modifies to a slight extent the viscosity-temperature stability. Tetrahydronaphthalene and decahydronaphthalene have slightly lower viscosity-temperature gradients than naphthalene as shown by Fig 4

Association and Viscosity-Temperature Stability.

The rate of change of viscosity with change of temperature is influenced greatly by association of the hydrocarbon. The degree of association in liquids decreases with increase of temperature, and therefore temperature change will be accompanied by a change in viscosity due to alteration of the association factor, as well as the normal viscosity change of the unassociated liquid

The lower hydrocarbons as a class have little tendency to association, but small differences in the degree of association have an important effect on the temperature coefficient of viscosity. Values of the association factor calculated by McLeod [22, 1925], Ramsay and Shields [26, 1893], Bingham [4, 1909], and Traube [32, 1897] are given in Table I

TABLE I

Hydrocarbon	Association factor			
	McLeod	Ramsay and Shields	Bingham	Traube
Octane	0.93	0.93		
Benzene	1.37	1.01	1.14	1.05
Toluene	1.08		1.06	
Ethylbenzene	0.91		1.02	
o-Xylene	1.02		1.06	
m-Xylene	0.92		1.00	

The difference in the slopes of the viscosity-temperature curves for benzene and toluene can be accounted for in part by the difference in the degree of association, benzene, being more highly associated than toluene, has an abnormally high viscosity and viscosity-temperature gradient

Although the simpler hydrocarbons as a rule undergo

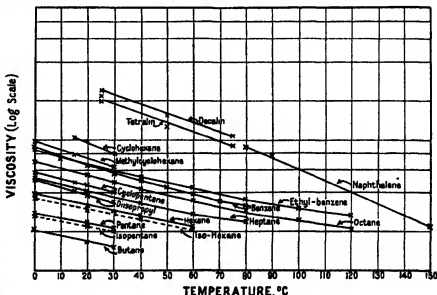

FIG 4.

association to a small extent, those of higher molecular weight may be highly associated (Staudinger [28, 1933], Yamaguchi [37, 1934]) The hydrocarbons present in lubricating-oil fractions form molecular aggregates approaching colloidal dimensions, so that a lubricating oil may be considered as a polyphase system in which hydrocarbon molecular aggregates are dispersed in a hydrocarbon medium of simpler molecular structure

The viscosity characteristics of the lower hydrocarbons have been shown in this discussion to be influenced by constitution, and it has been seen that with increasing molecular weight association tends to become an important factor affecting the physical properties A study of the lubricating-oil hydrocarbons with respect to viscosity and viscosity-temperature stability will therefore demand consideration of both constitution and association

High Molecular Weight Hydrocarbons.

The molecular constitution of the hydrocarbons present in lubricating-oil fractions may consist to a greater or less extent of paraffinic, naphthenic, aromatic, or polynuclear structures Examination of the viscosity-temperature curves of high molecular weight hydrocarbons of known structure will show to what extent the general rules relating viscosity and constitution of the simpler low molecular weight hydrocarbons are followed by the more complex compounds, and such comparison may throw light upon the constitution of the various classes of petroleum lubricating-oil hydrocarbons Hydrocarbons of high molecular weight have been synthesized by several investigators (Suida and Planckh [29, 1933], Landa and Coch [15, 1934], Lerer [17, 1933]) and the physical properties determined The viscosity-temperature data for these hydrocarbons are given in Table II, the corresponding curves being shown in Figs 5, 6, and 7 From this it is seen that the aliphatic hydrocarbons have lower viscosities than corresponding hydrocarbons with cyclic structure

No conclusions can be reached as to the effect of unsaturation and branching, because these synthetic aliphatic hydrocarbons have widely dissimilar structures and, with the examples given in the table, it is impossible to isolate the effects due to number, position, and length of branch

chains and position of the olefinic bond The long-chain structure of 16-n-butylheptacosane is accompanied by a viscosity-temperature curve which is less steep than the curves for the comparable hydrocarbons dimethyldihydroxystadecane and tricaprylene which have more highly branched structures

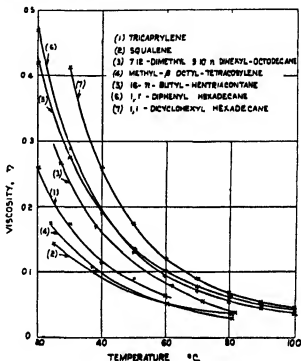

FIG 5

The introduction of simple benzene and naphthene rings into the molecule raises the viscosity to a moderate extent, but is accompanied by only a very slight increase in the gradient of the viscosity-temperature curve This is illustrated by the curves for 1,1-diphenylhexadecane, 1,1-dicyclohexylhexadecane, 1-phenyl-2-benzylheptadecane, and

TABLE II

Hydrocarbon	Structure	Formula	Viscosity in centipoise at										
			20° C	30° C	40° C	50° C	60° C	70° C	80° C	90° C	100° C		
Tricaprylene	Aliphatic	C ₂₆ H ₅₄	29.5	17.4	11.5	9.0	6.4						
Squalene	"	C ₃₀ H ₅₈		12.4	9.1	6.8	5.2	4.2	3.7				
7,12-Dimethyl-9,10-n-dihydroxystadecane	"	C ₂₈ H ₅₆		23.3	16.0	11.4	8.1	5.8	4.1				
Methyloctyltriacetylene	"	C ₂₈ H ₅₄			13.8	9.7	7.0	5.1	3.8	3.0			
16-n-Butylheptacosane	"	C ₃₆ H ₇₄	42.0	27.5	19.0	13.5	10.0	7.7	6.1	4.9	4.1		
Dimethyltetrahexyldocosane	"	C ₃₄ H ₇₀		123.0	66.0	40.0	26.0	18.0	13.0				
1,1-Diphenylhexadecane	Alkylated aromatic	C ₃₄ H ₅₂	47.1	28.9	18.9	13.0	9.4	7.0	5.5	4.5	3.7		
1,1-Dicyclohexylhexadecane	Alkylated naphthenic	C ₃₄ H ₅₄	70.7	41.4	25.8	17.4	12.3	8.9	6.9	5.5	4.4		
1-Cyclohexyl-2-hydroxybenzylheptadecane	"	C ₃₀ H ₅₄	62.9	37.8	24.3	16.0	11.6	8.4	6.5	5.0	4.3		
1-Phenyl-2-benzylheptadecane	Alkylated aromatic	C ₃₀ H ₅₀	81.5	48.4	28.1	18.4	12.7	9.0	7.0	5.0	4.4		
Dimethylisobutyldihydro-naphthalene	Alkylated polynuclear aromatic	C ₂₈ H ₅₀	59.9	31.2	20.1	12.8	8.0	5.5					
Tetrahydroisobutyl-naphthalene	"	C ₂₈ H ₅₀	40.3	22.0	14.0	9.0	6.0	4.4					
Disubstitutednaphthalene	"	C ₂₈ H ₅₀	47.6	24.0	14.0	9.0	6.0	4.4					
Dihydrodisubstitutedanthracene	"	C ₂₈ H ₅₀	137.0	70.0	28.0	17.0	11.0	7.3					
Dihydrodisubstitutedanthracene	"	C ₂₈ H ₅₀	5,086.0	420.0	184.0	80.0	40.0	25.0					
Dihydrodisubstitutedanthracene	"	C ₂₈ H ₅₀	520.0	232.0	112.0	57.0							

1-cyclohexyl-2-hexahydrobenzylheptadecane These four hydrocarbons may be considered as *n*-hexadecane structures to which have been attached in the 1,1- position phenyl, cyclohexyl, benzyl, and hexahydrobenzyl groupings

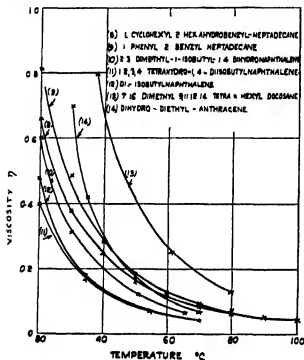

FIG 6

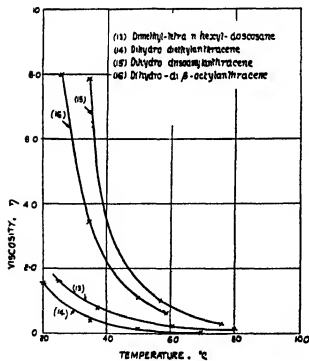

FIG 7

respectively. The curve for the phenyl-substituted compound is closely parallel to that of the cyclohexyl derivative, and the benzyl and hexahydrobenzyl derivatives also have similar viscosity-temperature curves. Hydrogenation

of the cyclic component does not alter the viscosity in the same direction for the phenyl and benzyl derivatives. The aromatic and naphthenic derivatives have similar viscosities and viscosity-temperature stabilities.

The introduction of polycyclic structure into the hydrocarbon molecule results in a marked decrease of the viscosity-temperature stability. Naphthalene derivatives have moderate viscosities at normal temperature and steep viscosity-temperature curves. Alkylated anthracenes have much higher viscosities at ordinary temperature and still lower viscosity-temperature stabilities. In Fig 7 the steep gradients of the curves for the anthracene derivatives (curves 15 and 16) are in contrast to the flat curve of the aliphatic hydrocarbon, dimethyltetrahexyldocosane (curve 13). Dihydrodiethylanthracene has a flat curve in Fig 7, this, however, is due to its low viscosity, and when compared in Fig 6 with hydrocarbons of similar viscosity the anthracene derivative is seen to have a relatively poor viscosity-temperature stability. Mikeska [23, 1936] in a report on the synthesis and physical properties of fifty-two high molecular weight hydrocarbons gives the following conclusions:

1 Reduction of the aromatic to the corresponding hydro-aromatic rings increases the viscosity but does not affect the viscosity index appreciably.

2 The viscosity index of a given aromatic or naphthenic hydrocarbon increases as the ratio of paraffinic to naphthenic or hydro-aromatic carbon atoms is increased, provided the number of chains remains unchanged, i.e. provided the total length of the molecule is increased. The nature of the cyclic nucleus determines the extent of the effect which a side chain of a given length may exert on the viscosity index of a given hydrocarbon.

3 A long paraffinic side chain is more effective in increasing the viscosity index of a given hydrocarbon than a corresponding number of carbon atoms divided among two or more side chains.

4 For the same number of carbon atoms, straight chains are more effective in increasing viscosity index than branched chains.

5 Olefinic bonds in the side chain decrease the viscosity, but have small and irregular effects upon the viscosity index.

6 The position of a cyclic nucleus within the molecule apparently has only a slight effect upon the viscosity and viscosity index.

In summarizing, it may be stated that the straight-chain aliphatic hydrocarbons have low viscosities in relation to the number of carbon atoms in the molecule, and very good viscosity-temperature stabilities. Hydrocarbons containing simple cyclic groups have higher viscosities and good viscosity-temperature stabilities, but the introduction of polycyclic structure into the molecule increases the viscosity to a marked extent and depresses the viscosity-temperature stability.

Evaluation of the Viscosity-Temperature Relationship for Hydrocarbons

The relationship between viscosity and temperature is most simply illustrated by graphical means through the viscosity-temperature curve on appropriate coordinates. It has already been pointed out that this method does not afford a satisfactory comparison for hydrocarbons of widely differing viscosity, and, in addition, it does not give any numerical evaluation of the change in viscosity with temperature.

The change in viscosity for any given increment of temperature, in the case of any hydrocarbon, is primarily dependent on the viscosity. As the temperature increases, with corresponding decrease in viscosity, the same increments of temperature are accompanied by progressively smaller changes of viscosity. Viscous hydrocarbons, as a consequence, show relatively large viscosity changes when compared with less viscous hydrocarbons over the same temperature range. Therefore the function $d\eta/dt$ denoting change in viscosity with temperature, for any hydrocarbon, varies continuously according to the viscosity and temperature, and it is not possible satisfactorily to compare viscosity-temperature coefficients unless the viscosity and temperature are also taken into consideration.

If the viscosity of a hydrocarbon or of a petroleum fraction in absolute, kinematic, or commercial units is plotted directly against temperature, the curve obtained is approximately hyperbolic, and is quite unsuitable for extrapolation. In consequence many types of empirical formulae have been derived to fit the known viscosity-temperature data.

The first formula connecting viscosity and temperature was given by Poiseuille [24, 1846], who found that the viscosity η_1 of water at temperature t' could be expressed in terms of the viscosity η_0 at 0° by the empirical formula

$$\eta_1 = \eta_0(1 + at + bt^2)$$

Slotte [27, 1892] proposed several formulae including

$$\eta = \frac{C}{(a+t)^n} \quad \text{or} \quad \eta_1 = \eta_0(1+bt)^n,$$

where a , c , b , and n are constants.

In a classical research upon the temperature-viscosity curves of about 70 pure liquids, including many hydrocarbons, Thorpe and Rodger [31, 1894] found that the above equation of Slotte represented fairly accurately the experimental viscosity-temperature data. Slotte's formula has been modified by Batschinski [2, 1901] and later by Dorsey [9, 1915]. If the equation is written in the form

$$\eta_1 = \frac{C}{(t-a)^n}$$

and n is equal to 3 and a is -273 the formula becomes Batschinski's, whereas if n is equal to unity and a is the apparent temperature of solidification the equation becomes that of Dorsey. Bingham [5, 1906] introduced the term fluidity or reciprocal of viscosity and suggested the expressions

$$\phi = \frac{c}{\phi_0 - at - b}$$

(ϕ is fluidity or $1/\eta$) and

$$t = A\phi - \frac{B}{\phi} + C$$

These equations are equivalent when

$$A = 1/a, B = c/a, C = -b/a$$

These formulae correlate a large amount of viscosity-temperature data in a satisfactory manner, but do not represent a simpler connexion between fluidity and temperature than those suggested for viscosity and temperature.

A relationship between the viscosities of pairs of chemically unrelated liquids at different temperatures was observed by Porter [25, 1912], who showed that when the absolute temperatures of pairs of liquids at equal viscosities are compared, the ratios of the two temperatures of equal viscosity plotted against either of the corresponding

absolute temperatures approximated to a straight line. This relation is satisfied by any formula of the type

$$\eta = \phi(b + c/T),$$

where ϕ is a universal function and b and c are specific to each substance.

For petroleum fractions approaching the lubricating-oil range Eckart [10, 1914] found that the relation between viscosity and temperature when plotted on logarithmic scales gave close approximation to a straight line, he proposed a formula which is essentially a special case of the general relation due to Slotte. This modification takes the form

$$\log \eta - a \log t + k_1,$$

$$\log \nu - b \log t + k_2,$$

where η is the absolute viscosity in poises, ν the kinematic viscosity in centistokes, t the temperature in degrees Fahrenheit, and a , b , k_1 , and k_2 are constants.

Following upon Eckart's work the American Society for Testing Materials have proposed a chart based on the fact that a linear graph results from plotting the logarithm of the absolute temperature against the loglog of the kinematic viscosity plus a constant. This empirical relationship, which has proved extremely useful, may be written

$$\log \log (\text{centistokes} + 0.8) - A \log T + B$$

Two viscosities at specified temperatures will evaluate the constants A and B , but for interpolation and extrapolation it is convenient to use the special A S T M charts published for this purpose. If the empirical relationship is expressed without logarithms it becomes

$$(\nu + 0.8) = e^{BT^A}$$

A similar exponential function for the correlation of viscosity and temperature was proposed by Crague [7, 1933], who claimed that the viscosity of a liquid relative to temperature could be represented by

$$\eta = Ae^{\nu/t} \quad \text{and} \quad \nu = Ae^{\mu/t},$$

where η and ν denote the absolute and kinematic viscosities respectively in C G S units, A and B are constants having values of 5×10^{-4} and $1,000 \log_e 20$ respectively. L is a function of absolute viscosity which is linearly related to temperature and may be expressed as

$$L = L_0 \{1 + a(t - t_0)\},$$

where L_0 is the value of L at the reference temperature t_0 . If the viscosity is recorded in centistokes L' is substituted for L . A series of tables facilitates conversion of viscosities in absolute, kinematic, and commercial units to the corresponding functions L or L' .

A relationship resembling that upon which the A S T M chart is based was developed by Walther [34, 1931], this may be written in the alternative forms

$$(\nu + 0.8)^{T^m} = k',$$

$$T^m \log(\nu + 0.8) = k'',$$

$$m \log T + \log \log(\nu + 0.8) = k'''$$

Consideration of liquid viscosity from the point of view of the kinetic theory of gases is criticized by Andrade [1, 1934], who states that the problem should be approached from the point of view of the solid state, the density of which is not markedly different from that of the liquid state of the same substance. In his theory of the viscosity of liquids he derives from theoretical considerations the formula

$$\eta \nu^{1/3} = Ae^{c/T}$$

where η is the viscosity of the liquid, v its specific volume, T the absolute temperature, and A and c are constants. This equation showed excellent agreement with the experimental data of Thorpe and Rodger. Various expressions for the viscosity-temperature relation have been proposed by other workers, including Graetz [11, 1877] and Vogel [33, 1921]. These are generally variants of the fundamental form

$$\frac{d\eta}{dt} = \frac{-k(\eta-a)}{(t-t_0)^n},$$

where a , k , and n are constants.

Viscosity-Temperature Relationship for Lubricating Oils.

Lubricating oils for use in internal-combustion engines must be sufficiently mobile at low temperatures to enable easy starting from cold and satisfactory lubrication during the warming-up period of engine operation, in addition the lubricant must retain sufficient viscosity at the highest engine operating temperatures to carry the loads imposed and eliminate undue wear of the bearing surfaces. Therefore the temperature coefficient of viscosity is a most important characteristic of lubricating oil. Various methods have been developed for the comparison of the viscosity-temperature changes of oils, the most important of these are outlined below.

(1) **Charts.** Within a limited range of temperature and viscosity, the relation between temperature and viscosity may be expressed by straight lines on a double logarithmic diagram. Charts based on this were developed by MacCoubil [21, 1921] and Herschel [12, 1922], but the most widely used at the present time is that issued by the American Society for Testing Materials in 1932 (see p 1087) and known as the A S T M Tentative Standard D 341-32 τ Oils may be compared directly on this chart by plotting the viscosities at any two temperatures and drawing a straight line through the points.

(2) **Bell and Sharp System** [3, 1933]. This is based on the A S T M chart and classifies oils according to the slope of the straight viscosity-temperature line. Two linear scales of arbitrary units are imposed on the chart, one vertically and the other horizontally, the value of the slope is then expressed as the tangent of the angle which the viscosity-temperature line makes with the horizontal, and is recorded in arbitrary units. To obviate the necessity of using charts with superimposed scales tables are given which enable the value of the slope to be calculated.

(3) **Viscosity Gradient.** This was proposed by Clayden [6, 1933] in an endeavour to place the measurement of viscosity-temperature change on a fundamental basis. The viscosities of the given oil at 100° F and 210° F are plotted on the A S T M chart and a line parallel to this is drawn passing through the point 10,000 centistokes on the 32° F ordinate, for ordinary oils this second line will cut the 212° F ordinate between 9 and 40 centistokes, and this value is termed the viscosity gradient. The geometrical construction involved suffers from the disadvantage that the viscosity scale, being logarithmic, gives adequately large differences of viscosity gradient at the lower end of the scale, but at the upper end the differences are small. To overcome this the length of the line between 0° F and 210° F is taken as a measure of the viscosity gradient and a table gives the relation between length of line and viscosity gradient.

(4) **Viscosity Pole Height.** The viscosity-temperature relation is expressed by Walther [35, 1933] in the straight line form

$$W_T = W_T - m(\log T_1 - \log T),$$

where m is a constant, T and T_1 absolute temperatures, and $W = \log(v+0.8)$ v being viscosity in centistokes. These straight lines, when plotted on logarithmic charts of the A S T M type, for oils of the same chemical character or similar origin intersect at a point. This point of intersection is termed the viscosity pole and its corresponding value W in Walther's formula which is called the viscosity pole height (V P) is characteristic for oils of the same chemical type. The viscosity pole height can be calculated by substitution of viscosity-temperature values of at least two oils of the same type in Walther's equation. Where data for only a single oil are available the V P can be ascertained by the fact that the viscosity poles for oils of different chemical types lie on a straight line for which the equation

$$\log T = 2.410 - 0.194W$$

has been found.

For ordinary mineral lubricating oils the viscosity pole height ranges between 1 and 6, being low for oils with low temperature coefficient of viscosity.

The viscosity pole height can be calculated as follows assuming the viscosities of the oil at two temperatures, e.g. 100° F and 200° F, are known. W_{100} and W_{200} are obtained by substitution in $W_T = \log(v+0.8)$ m in Walther's straight line equation is obtained from

$$m = \frac{W_{200} - W_{100}}{(\log 366.3 - \log 310.8)}$$

The basic equation can be expressed in the form

$$\log T = \frac{W_T - b}{m},$$

and the constant b can be obtained by substituting the known values of T , W_T , and m . The viscosity pole lies on the line

$$\log T = 2.410 - 0.194W$$

Combining the last two equations, W , the pole height, is found by substitution of known values of b and m in

$$W = \frac{2.410m + b}{1 + 0.194m}$$

This expression is only suited for lubricating oils, i.e. oils with a viscosity of at least 5 centistokes at 200° F. An advantage of this form of expressing the temperature coefficient of viscosity is that it can be calculated from viscosities at any two temperatures without involving graphical extrapolation.

(5) **Zero Viscosity Factor.** This expression was proposed by McCleuer and Fenske [19, 1934] for the comparison of oils at two widely divergent temperatures, corresponding approximately to winter starting and normal operation. For reference purposes a single type of oil, of extreme paraffin base character, is used. The viscosities at 100° F and 210° F of any of the reference series are connected by the equation

$$\log V_{100} = 1.502 \log V_{210} + 0.4400$$

The given oil is compared with a reference oil of the same viscosity at 210° F, and the ratio of the viscosity of the given oil at 0° F to the viscosity of the reference oil at the same temperature is termed the zero viscosity factor. The viscosities at 0° F are obtained either by extrapolation on the A S T M chart or by substitution of known values in the basic equation

$$\log \log(v+0.8) = A \log T + B,$$

Calculations may be avoided by use of a nomograph, by means of which the zero viscosity factor of oils may be determined from the viscosities at 100° F and 210° F.

(6) and (7) **Viscosity Index and Viscosity Gravity Constant.** These two systems for the classification of oils are discussed in a separate article by P. Docksy.

(8) **Viscosity Index Zones.** The viscosity temperature relations of a series of cuts of Pennsylvanian and Gulf Coast crudes, resembling the *H* and *L* series of Dean and Davis [8, 1929] used in the Viscosity Index System, were determined by Larson and Schwaderer [16, 1932]. These values were plotted on the Sinclair Viscosity Temperature Chart (later superseded by the A S T M chart), taking one specific viscosity at 210° F, the angle formed between the lines for the basic oils on the chart was divided into eight zones of equal size. This procedure was followed for all necessary viscosities at 210° F and the zones replotted on a viscosity index zone chart with Saybolt viscosities at 100° F as ordinates and Saybolt viscosities at 210° F as abscissae. The viscosity index zone is obtained from the chart by finding the intersection of the ordinate and abscissa corresponding to the viscosities at 100° F and 210° F. This point of intersection will lie in one of the zones, and a classification of the oil is thus effected.

(9) **Gravity Index.** The methods of evaluating the temperature coefficient of viscosity so far described rely on the availability of the viscosities of the given oil at two temperatures. In many cases published data only give the viscosity at one temperature, together with the specific gravity, and it was for cases of this type that McCluer and Fenske [20, 1932] devised the 'gravity index'. The viscosity gravity constant introduced by Hill and Coats [13, 1928] classifies oils according to their Saybolt viscosity at 100° F or 210° F and specific gravity at 60° F; paraffinic oils have a viscosity constant of about 0.8, while for naphthenic oils the value is about 0.9. Paraffinic oils have high viscosity indices and naphthenic oils low, and it would be natural to expect some relation between viscosity gravity constant and viscosity index. From data obtained on a hundred oils McCluer and Fenske have shown that such a relation does exist, for viscosity gravity constant plotted against the corresponding viscosity index gives a fairly smooth curve. From the specific gravity at 60° F and the Saybolt viscosity at 100° F or 210° F the viscosity gravity constant can be obtained, and reference to the curve gives the corresponding value of the viscosity index. The viscosity index obtained in this way is termed the Gravity Index.

(10) **Modified Fractional Viscosity Temperature Coefficient.** Practically all the systems for expressing the rate of change of viscosity with temperature are based either on an arbitrarily chosen series of oils or upon some empirical relation. The function

$$\frac{\Delta\eta}{\Delta t} \frac{1}{\eta \log \eta}$$

(η = absolute viscosity in centipoises) calculated for various high molecular weight hydrocarbons at different temperatures has been shown by Wiggins [36, 1936] to be approximately constant and characteristic of the chemical type of the hydrocarbon. In this expression $\Delta\eta$ represents a small change of viscosity corresponding to a small but finite temperature interval Δt independent of t .

This function, which is independent of any reference series,

is termed the modified fractional viscosity temperature coefficient. The corresponding function

$$\frac{\Delta v}{\Delta t} \frac{1}{v \log v}$$

using kinematic units, calculated for Pennsylvanian and Gulf Coast oils, is a characteristic of the oils but is only approximately constant, decreasing slightly with increase in temperature. A further expression has been developed

$$\frac{\Delta \left(\frac{\Delta V}{V \Delta t} \right)^{100^\circ F}}{\Delta t \log \frac{V_{210^\circ F}}{V_{100^\circ F}}}$$

which is a characteristic of the chemical type of the oil, Pennsylvanian oils having values of 4 to 4.5, while naphthenic oils have higher values of 6 to 8. This function enables comparison to be made without reference to any standard series of oils or to any other empirical equation.

Improvement of Viscosity-Temperature Characteristics of Lubricating Oils.

The temperature coefficient of viscosity as evaluated for lubricating oils by the viscosity index is in most cases approximately additive, so that in order to improve an oil with low viscosity index, blending with an appreciably large amount of high viscosity index oil is necessary.

The addition of certain high molecular weight hydrocarbon materials to mineral oils results in the formation of solutions with relatively high viscosity which have the essential viscosity characteristics of colloidal suspensions or emulsions; these are discussed by Lewis and Squires (loc cit.). The viscosity of a dilute suspension of rigid, spherical particles, uniform in size, is given by the Einstein equation

$$\eta = \eta_0 \frac{1 + 0.5v}{(1 - v)^2}$$

which for low values of v simplifies to

$$\eta = \eta_0(1 + 2.5v)$$

in which η_0 is the viscosity of the liquid in which the particles are suspended, η the viscosity of the suspension, and v the volume fraction of the suspended particles. Temperature change does not affect the volume fraction of the suspended particles appreciably, and it can be shown that the fractional change in viscosity with temperature of such a suspension corresponds to that of the solvent. Thus these non-homogeneous liquids have temperature coefficients of viscosity which are low in comparison with their viscosities.

Many of these high molecular weight colloidal materials give solutions or suspensions with viscosities higher than those indicated by the Einstein equation. This is attributed either to solvation or to the Staudinger flow interference effect of rod-like particles. With this flow interference effect, the viscosity of the suspension is a function of the concentration of solute and its molecular weight, the molecular weight does not change appreciably with temperature, and the temperature coefficient of viscosity of the suspension is practically the same as that of the solvent. Thus it appears possible to prepare 'non-homogeneous' oils with relatively low temperature coefficients of viscosity or high viscosity indices. The main difficulties are the tendencies of these suspensions to gel at low temperatures and for their viscosity to fall with continued mechanical shear.

REFERENCES

- 1 ANDRADE, E N DA C *Phil Mag* 17, 496, 698 (1934)
- 2 BAYCZYNSKI, A *Beibl* 25, 231 789 (1901)
- 3 BELL, T G, and SHARP, L H *Oil and Gas J* 32 (13), 13 (1933)
- 4 BINOHAM, E C Z *Physik Chem* 66, 1 (1909), *Amer Chem J* 43, 302 (1910)
- 5 ——— *Amer Chem J* 35, 195 (1906), *ibid* 40, 277 (1908), *ibid* 43, 287 (1910)
- 6 CLAYDEN, A L *Nat Petr News*, 25 (42), 27 (1933)
- 7 CRAGOE, C S *Proc World Petr Cong* 2, 529 (1933)
- 8 DEAN, E W, and DAVIS, G H B *Chem Met Eng* 36, 618 (1929)
- 9 DONSEY, N E *Trans Amer Soc Mech Eng* 37, 190 (1915)
- 10 ECKHART, W R *J Amer Soc Mech Eng* 263 (1914)
- 11 GRAETZ, L *Wied Ann* 2, 387 (1877), *ibid* 34, 25 (1888)
- 12 HERSCHEL, W H *Ind Eng Chem* 14, 715 (1922), *Oil and Gas J* 25 (28) 146 (1926)
- 13 HILL, J B, and COATS, H B *Ind Eng Chem* 20, 641 (1928)
- 14 HUGEL, M G *Congres du Grissac*, Strasbourg, 1931
- 15 LANDA, S, and CTCH, J *Collection Czechoslov Camm* 6, 423 (1934)
- 16 LARSON, C M, and SCHWADERER, W C *Nat Petr News*, 24 (2), 25 (1932)
- 17 LERER, M *Ann Comb Liq* 8, 687 (1933)
- 18 LEWIS W K, and SQUIRES, L *Proc A P I* 15 (iii), 69 (1934)
- 19 McCLUER W B, and FENSKER, M R *Ind Eng Chem, Anal Ed* 6, 389 (1934)
- 20 McCLUER, W B, and FENSKER, M R *Ind Eng Chem* 24, 371 (1932)
- 21 MACCOULL, N *Lubrication*, 5 June 1921 (Published by Texas Oil Co)
- 22 McLEOD, D B *Trans Faraday Soc* 21, 151 (1925)
- 23 MIKESKA, L A *Ind Eng Chem* 28 (8), 970 (1936)
- 24 PONSUILLLE, J L M *Mém Savants Evangers*, 9, 433 (1846)
- 25 PORTER, A W *Phil Mag* (6), 23, 458 (1912)
- 26 RAMSAY, W, and SHIELDS, J *Trans Chem Soc* 63, 1089 (1893)
- 27 SLOTT, K F *Beibl* 16, 182 (1892)
- 28 STAUDNER, H *Trans Faraday Soc* 29, 18 (1933)
- 29 SUEDA, H, and PLANCKI, R *Ber* 66 n, 1453 (1933)
- 30 SULLIVAN, F W, VOORHEES, V, NEELEY, A W, and SHANKLAND, R V *Nat Petr News*, 23 (22), 47 (1931)
- 31 THORPE, T E, and RODGER, J W *Phil Trans*, A 185, 397 (1894)
- 32 TRAUBE, J *Ber* 30, 273 (1897)
- 33 VOGEL, H *Physik Z* 22, 645 (1921), *Z angew Chem* 35, 561 (1922)
- 34 WALTHER, C *Erdöl u Teer*, 7, 382 (1931), *Kohlenwasserstoffe Halde*, 10 (Berlin, 1933)
- 35 ——— *Proc World Petr Cong* 2, 419 (1933)
- 36 WIGGINS, W R *J I P T* 22, 305 (1936)
- 37 YAMAGUCHI, B *Ind Eng Chem* 23, 604 (1931), Report of the Aeronautical Research Inst, Tokyo Imperial University, no 102, 8 (6) Feb 1934

VISCOSITY INDEX AND VISCOSITY GRAVITY CONSTANT

By P. DOCKSEY, B.A.

Anglo-Iranian Oil Company Ltd

1. VISCOSITY INDEX

Introduction

Viscosity Index, or as the phrase is commonly abbreviated, VI, is a function designed to express the variation of viscosity with temperature. While a measure of the rate of change is of value for its own sake, it is of great use also as a measure of 'paraffinity' or 'naphthenicity', since it is found that those oils which are commonly termed paraffinic in quality have lower rates of change of viscosity with temperature than those termed naphthenic. VI is used to a very great extent as an index of paraffinity when following the course of a refining treatment, and indeed in this field lies its greatest use.

There are obviously several ways of expressing the viscosity-temperature relationship of an oil, and these are briefly dealt with in this article. The desirable properties of such a function are that it should be of simple derivation (that is, not dependent on complex mathematical formulae, unless these can be shown to have a sound physical basis), it should be practical and capable of readily allowing one to visualize the qualities of an oil, and that it should provide a scale which is even, and does not, when applied to practical problems, appear to be unduly open at one end and closed at the other. Of the various methods proposed, one, that proposed by Dean and Davis, has become generally accepted to the exclusion of the others, and it may be said to fulfil the first two requirements well. Whether or not this method, or any of the others proposed, exactly fulfils the third requirement is a more open question, but the great extent to which VI, as proposed by Dean and Davis, has been applied to many practical problems is a guarantee that their VI scale fulfils it to a satisfactory degree.

The A.S.T.M. Viscosity Formula

Before proceeding to a further consideration one fact must be brought forward, since in one way or another it underlies all the methods proposed. It is that the viscosity-temperature relation of hydrocarbon oils has been found to be capable of being expressed by the formula

$$\log(\nu+0.8) = a \log T + b,$$

where ν = kinematic viscosity, centistokes,
 T = temperature °Abs,
 a, b = constants for any one oil

This formula, which is purely empirical, is the basis of the well-known A.S.T.M. Viscosity-Temperature chart (D 341-32r), on which viscosity-temperature lines of oils may be plotted in straight lines. This method of plotting has been widely tested, and is successful over a wide temperature range as long as the oils remain true Newtonian liquids. At low temperatures near the set-point, curvature of the lines occurs due to the appearance of wax. Some of the difficulties associated with this region are discussed later, but for the main part it may be taken that the above equation may be applied.

The fact that the viscosity-temperature line can be made straight by means of this formula suggests the possibility of measuring the viscosity-temperature characteristic by means of the slopes of the straight lines. As pointed out by Clayden [2, 1933], the actual measurement of the slope of the lines as drawn on the A.S.T.M. chart is ambiguous and unsatisfactory, and he outlines a method by which this difficulty may be overcome. The result, however, is to produce a system which is very artificial. Bell and Sharp [1, 1933] and Nevitt [9, 1933] also propose the use of the slope on the A.S.T.M. chart as a measure of viscosity index.

A second method is to determine the constants a and b in the formula given above by inserting experimental values of the viscosity at two temperatures and solving. The procedure is laborious, but could be made workable by drawing, as a preliminary, graphs giving the relation between a and b and the viscosities at two temperatures. One merit would be that the values of a and b could be calculated, if desired, from viscosities measured at any two temperatures. A difficulty arises in interpreting the results. This is due fundamentally to the fact that the A.S.T.M. formula has no strict physical basis, so that the constants a and b have no meaning in themselves. The values of a and b can only be interpreted practically by comparison with other oils, and this immediately brings up the desirability of the use of reference oils, that is, oils whose physical characteristics are familiar and which will be accepted as standards with which other oils can be compared.

A further method [10, 1933] has been proposed which is based directly on the use of the A.S.T.M. chart. It is found that if the viscosity-temperature lines of oils of various viscosities, all obtained from one base stock, are drawn on the A.S.T.M. chart and extrapolated, they all pass through a single point. The position of this point can then be used as a measure of the type of crude from which the oil is obtained. Points can be located corresponding to various types of crude and combined into a scale. This method, sometimes known as the 'viscosity pole height', has been utilized in Germany. It is in many ways attractive, but suffers from being somewhat complicated.

Definition of an Oil by Values of Viscosity at Two Temperatures

As long as viscosity-temperature lines remain straight when plotted on the A.S.T.M. chart we may define the viscosity-temperature characteristics of an oil completely from a knowledge of the viscosity at two temperatures. This fact is of great importance since it underlies the method of Dean and Davis [2, 1929], and indeed any method in which two viscosities are taken as being sufficient to define an oil.

If this were not so it would be possible to obtain two oils one of which had a higher viscosity than the other at low and high temperatures, while at some intermediate temperature it had a lower viscosity. Such a state of affairs would be most confusing, and it is fortunate that it only occurs at temperatures approaching the set-point where oils are no longer true Newtonian liquids.

Reference Oils

It would obviously be advantageous in visualizing the characteristics of an oil to compare it with reference oils, and thus forms the basis of the method of Dean and Davis [2, 1929]. In view of what has been said in the last paragraph, it is legitimate to define the various reference oils

TABLE I

Cuts from Pennsylvania crude		Cuts from Gulf Coast crude	
Saybolt sec at 100° F	Saybolt sec at 210° F	Saybolt sec at 100° F	Saybolt sec at 210° F
242.5	49.0	180.0	42.0
313.0	53.3	280.0	46.0
414.0	59.5	420.0	50.0
545.0	67.0	570.0	55.0
727.5	76.5	750.0	59.0
971.5	89.0	930.0	63.0
1,292.0	105.0	1,210.0	71.0

by the viscosities at two temperatures, and those chosen were 100 and 210° F, which are in common use for tests in the U. S. A. It is desirable to choose reference oils which represent the extremes of natural oils, and hence Dean and Davis made a series of cuts from oils of Pennsylvanian

TABLE II
To be used in Computing Dean and Davis *V* I Values
from Viscosities at 100 and 210° F

<i>V</i> ₁ at 210° F	<i>V</i> ₂ at 100° F Series	<i>V</i> ₁ at 210° F L-H	<i>V</i> ₂ at 100° F Series	<i>V</i> ₁ at 210° F L-H	<i>V</i> ₂ at 100° F Series	<i>V</i> ₁ at 210° F	<i>V</i> ₂ at 100° F Series	<i>V</i> ₁ at 210° F L-H	<i>V</i> ₂ at 100° F Series
*40	138	31	81	1,674	864	121	3,902	2,259	
*41	161	41	82	1,721	892	122	3,966	2,301	
*42	185	52	83	1,769	920	123	4,031	2,343	
*43	210	63	84	1,817	949	124	4,097	2,387	
*44	237	76	85	1,865	977	125	4,163	2,430	
*45	265	89	86	1,914	1,007	126	4,229	2,473	
*46	293	102	87	1,964	1,037	127	4,296	2,517	
*47	322	116	88	2,014	1,067	128	4,363	2,561	
*48	353	131	89	2,064	1,098	129	4,430	2,605	
*49	386	147	90	2,115	1,129	130	4,498	2,650	
*50	422	165	91	2,166	1,160	131	4,567	2,696	
*51	456	184	92	2,217	1,191	132	4,636	2,742	
*52	491	203	93	2,270	1,224	133	4,705	2,787	
*53	525	220	94	2,322	1,256	134	4,775	2,834	
*54	561	239	95	2,375	1,288	135	4,845	2,880	
*55	596	259	96	2,428	1,321	136	4,915	2,927	
*56	632	276	97	2,481	1,353	137	4,986	2,974	
*57	669	295	98	2,536	1,388	138	5,058	3,022	
*58	706	315	99	2,591	1,423	139	5,130	3,070	
*59	743	335	100	2,646	1,457	140	5,202	3,118	
60	781	355	101	2,701	1,491	141	5,275	3,167	
61	819	376	102	2,757	1,526	142	5,348	3,216	
62	857	396	103	2,814	1,562	143	5,422	3,266	
63	897	419	104	2,870	1,597	144	5,496	3,316	
64	936	440	105	2,928	1,634	145	5,570	3,365	
65	976	462	106	2,985	1,670	146	5,645	3,416	
66	1,016	484	107	3,043	1,706	147	5,721	3,467	
67	1,057	507	108	3,102	1,744	148	5,796	3,518	
68	1,098	530	109	3,161	1,782	149	5,873	3,570	
69	1,140	554	110	3,220	1,819	150	5,949	3,621	
70	1,182	578	111	3,280	1,858	151	6,026	3,673	
71	1,225	602	112	3,340	1,896	152	6,104	3,726	
72	1,268	627	113	3,400	1,934	153	6,182	3,779	
73	1,311	651	114	3,462	1,974	154	6,260	3,832	
74	1,355	677	115	3,524	2,014	155	6,339	3,886	
75	1,399	702	116	3,585	2,055	156	6,418	3,940	
76	1,444	728	117	3,648	2,096	157	6,498	3,995	
77	1,489	755	118	3,711	2,138	158	6,578	4,049	
78	1,534	781	119	3,774	2,176	159	6,659	4,105	
79	1,580	808	120	3,838	2,218	160	6,740	4,160	
80	1,627	836							

* All values corresponding to these viscosities were calculated from data obtained with a modified Ostwald viscometer

stock (low rate of change of viscosity with temperature) and Gulf Coast stock (high rate of change). The viscosities of the various cuts are given in Table I.

These viscosities were measured on the Saybolt instrument, and for those oils having a viscosity of less than 50 sec Saybolt at 210° F the method of measurement is not sufficiently accurate. At a later date [1, 1932] these oils were remeasured, using an Ostwald viscometer, the figures obtained being converted to Saybolt seconds by the accepted conversion formula. Using these latest figures, a table was constructed showing the values of the viscosities at 100 and 210° F for both series of oils. (See Table II.) Larson and Schwarlder [8, 1932] state that they have checked Dean and Davis's figures for the two series of oils and are in agreement with them.

Dean and Davis System

V I as defined by Dean and Davis is a function of the ratio of the viscosity at 100° F to that at 210° F for the two reference oils and the unknown oil whose *V* I is to be measured.

Suppose that the oil whose viscosity-temperature curve is under consideration has a viscosity of *U* Saybolt sec at 100° F and *V* Saybolt sec at 210° F so that the ratio of the viscosities at these two temperatures is *U/V*. The smaller the ratio *U/V* the better is the oil from the point of view of viscosity-temperature change. Now it is known that the viscosity-temperature curves of oils from Pennsylvanian crude are remarkably good, while those of oils obtained from Gulf Coast crudes are among the worst obtainable for petroleum oils. A very good measure of the goodness or badness of the viscosity-temperature curve of

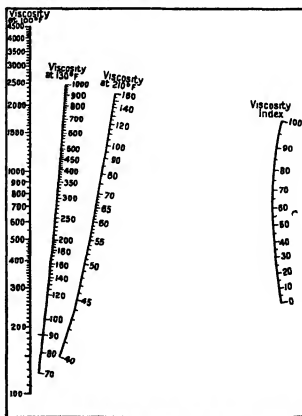

FIG. 1 (Reproduced by permission from 'Inst Petroleum Technology', March 1934)

the oil in question may therefore be obtained by comparing the ratio of the viscosities U/V with ratios of the viscosities of appropriate cuts from Gulf Coast and Pennsylvanian crudes. The question arises as to what may be considered appropriate cuts. If the unknown oil is of high viscosity, it would obviously be wrong to compare it with reference

The three ratios are combined into a function called the 'Viscosity Index' by the following relation

$$VI = \frac{L/V - U/V}{L/V - H/V} \times 100 = \frac{L - U}{L - H} \times 100$$

It will be obvious that Gulf Coast oils will have a viscosity

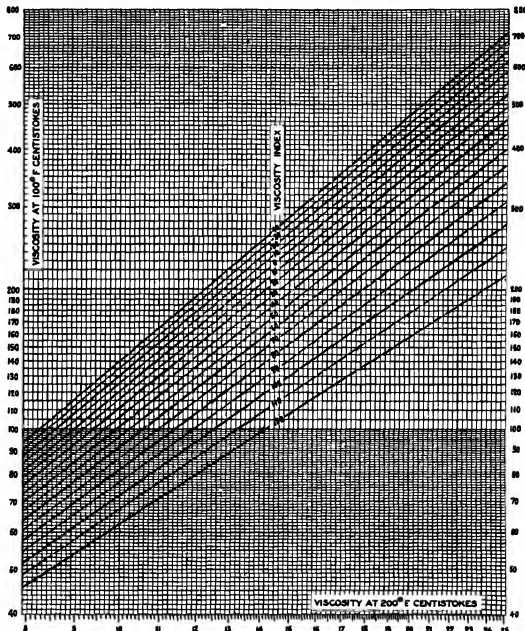

FIG 2 (Reproduced by permission from 'J Inst Petroleum Technology', March 1934)

oil of low viscosity, and the appropriate reference oils may be fixed by saying either that they shall have a viscosity of U Saybolt sec at 100° F or V Saybolt sec at 210° F. Dean and Davis chose the latter, and we are now able to compare the unknown oil with

- (1) A Pennsylvanian oil of viscosity H sec at 100° F and V sec at 210° F, i.e. a ratio H/V
- (2) A Gulf Coast oil of viscosity L sec at 100° F and V sec at 210° F, i.e. a ratio L/V

index of 0 and Pennsylvanian oils a viscosity index of 100 (This can be obtained by putting $U = L$ and $U = H$ in the above expression.) The range is not limited from 0 to 100. If the value of U is greater than L , the VI will be negative, and if less than H , values of over 100 may be obtained.

The figures for H and L may be obtained from Table II, which is based on curves drawn from the experimental figures for the reference oils already given.

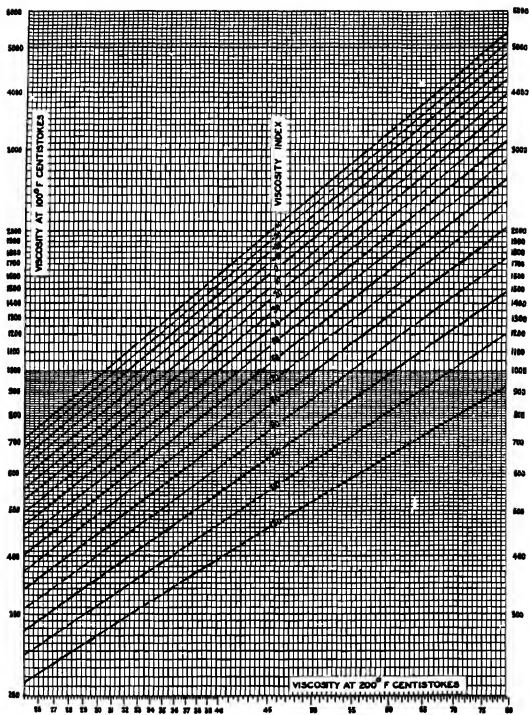

FIG 3

The V.I., therefore, can be determined by inserting values of U (obtained by experiment), H , and L in the formula. Alternatively it is possible to obtain the V.I. from a nomogram or chart, and that published by Dean and Davis

viscosity determinations are 100 and 200° F. in England and 50–100° C on the Continent. The charts [3, 1934] given on Figs. 2–5 allow the V.I. to be determined when the viscosities are measured at these temperatures. They have

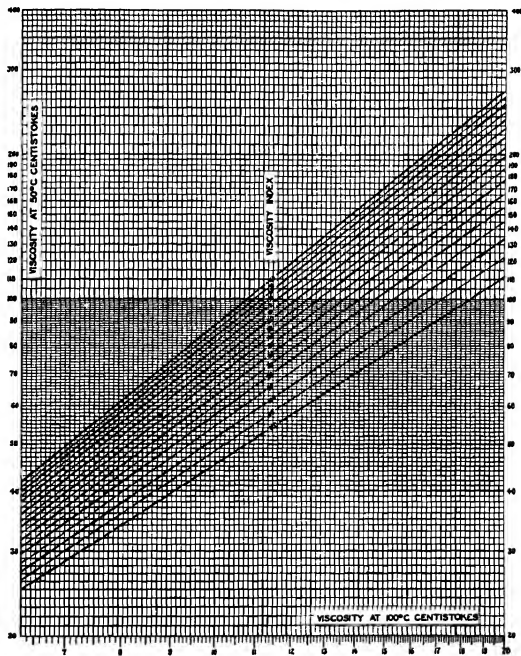

FIG 4

[2, 1929] is shown in Fig 1. This nomogram also allows the V.I. to be obtained from viscosity measurements at 130 and 210° F.

Charts for use at 100 and 200° F. or 50 and 100° C.

In England and on the Continent it is becoming customary to measure viscosities in kinematic units (stokes or centistokes). The temperatures normally employed for

been drawn to give agreement with the Dean and Davis system, and for this reason the charts for low-viscosity oils have not been taken below 8 centistokes at 200° F. For V.I.s outside the range of these charts (–40 to 120) the figures for the H and L oils should be taken from the lines marked 100 and 0, and inserted in the formula given above.

The figures given by Dean and Davis do not include oils of high viscosity, and these charts have been extrapolated for this purpose.

V.I. According to Hersh, Fisher, and Fenske

The use of Saybolt viscosities makes the Dean and Davis system inconvenient and inaccurate when low-viscosity oils are considered, and the use of kinematic viscosity would overcome this objection. Hersh, Fisher, and Fenske [4, 1935] accept the principle of the Dean and Davis system

viscosity at 100° F. and at 210° F for the Pennsylvanian reference oils

$$v_{210} = 2.808 \left[v_{100} - \frac{0.500}{v_{100}^{1.16}} \right]^{1.16} \quad (1)$$

where v_{100} = viscosity at 100° F in centistokes,
 v_{210} = " " 210° F " " "

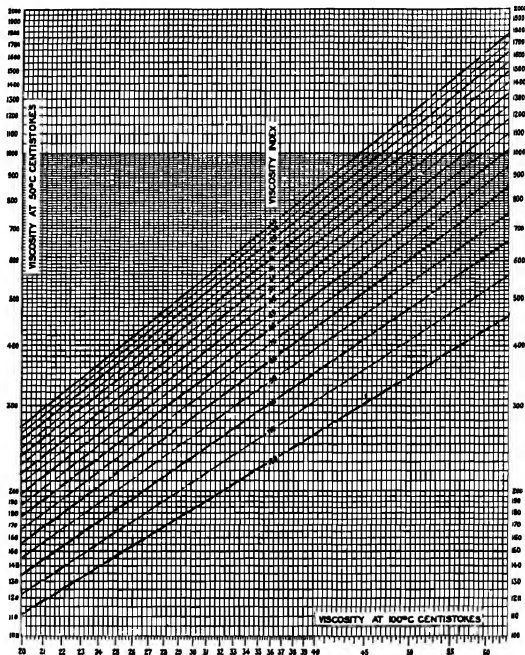

FIG 5

as to interpolating between the viscosities of two standard reference oils, but use viscosities in centistokes at 100 and 210° F. The relation between viscosity at 100° F. and viscosity at 210° F. has been greatly extended by a further series of experiments, and the following equation based on Dean, Davis, and Lapeyrou's experiments, Hersh, Fisher, and Fenske's experiments, and on data from the Standard Oil Development Company expresses the relation between

This equation covers a range of 4 to 7,000 centistokes at 100° F.

A similar equation for naphthenic oils (VI = 0) based on the data of Davis, Lapeyrou, and Dean, and data from the Standard Oil Development Company, is

$$v_{210} = 2.450 \left[v_{100} - \frac{0.213}{v_{100}^{1.16}} \right]^{1.16} \quad (2)$$

The VI can then be obtained by inserting values in the following equation

$$VI = \frac{L-U}{L-H} \times 100,$$

where L = viscosity of naphthenic oil at 100° F centistokes (from eq (2)),

H = viscosity of paraffinic oil at 100° F centistokes (from eq (1)),

U = viscosity of unknown oil at 100° F centistokes

Values of VI determined by this system will agree fairly well with those taken from Dean and Davis' chart for high-viscosity oils, but serious divergence will occur at low viscosities owing to the fact that Saybolt seconds are not directly proportional to kinematic viscosity

Larson and Schwarzerer System

Larson and Schwarzerer [8, 1932, 9, 1933] accept the relation between the viscosities at 100 and 210° F for the reference oils, and have verified them by further experiment. Instead of the arithmetical interpolation between the two reference oils as proposed by Dean and Davis, Larson and Schwarzerer carry out interpolation by drawing uniform angular zones between the lines for the high and low VI oils on the ASTM chart. Originally eight zones were chosen as being sufficient to cover the range between the H and L oils, but subsequently a scale of 100 divisions between these two oils was proposed, thus giving as finely a divided scale as Dean and Davis. This system does not offer any advantage over that of Dean and Davis, and the derivation of VI is not so direct. It does not appear to have been used to any extent in published work.

Discussion

The VI system, according to Dean and Davis, has become widely accepted. As already pointed out, it is subject to criticism on the score of inaccuracy at the low-viscosity end, this being wholly due to the unsuitability of the Saybolt instrument for measuring such viscosities accurately. This difficulty would be overcome by adopting Hersh, Fisher, and Fenske's equations for the two standard reference oils, and determining viscosities in an Ostwald viscometer in kinematic units. The whole definition of VI is a matter of convention, at present the Dean and Davis system, based upon viscosities in Saybolt seconds measured at 100 and 210° F, is most commonly used. It is to be hoped that in the future it will be possible to alter the convention to the use of kinematic viscosity, but it will still be necessary to base the system on two arbitrarily selected temperatures, those already used (100 and 210° F) being a probable choice. But until some such convention is adopted and generally recognized, confusion can only be avoided by keeping to one system, whatever its shortcomings may be. If this is not done, different observers will report different viscosity indices for the same oil or hydrocarbon, depending on the VI system which they choose to adopt. Watson [11, 1934] has shown that it is possible to devise a nomographic chart which would be of almost universal application in the determination of VI if a sound basic convention could be established.

2. VISCOSITY GRAVITY CONSTANT

It is well known that for oils of the same viscosity, those which are usually called paraffinic have low specific gravities compared with those called naphthenic. It ap-

pears possible that a means of correlating viscosity and specific gravity might be found which would allow a numerical index of paraffinity to be obtained which would allow the terms paraffinic and naphthenic to be interpreted in a more precise manner.

Measurements of viscosity and specific gravity were reported by Hill and Ferns [6, 1925] for five series of lubricating-oil cuts made from five different crudes, three of Gulf Coast origin, one Mid-Continent, and one Pennsylvanian. The viscosity range at 100° F was 40-2,000 sec. Saybolt on the Gulf Coast oils, 40-1,000 sec. Saybolt on the Mid-Continent, and 40-850 sec. Saybolt on the Pennsylvanian.

Hill and Coats [5, 1928] used these figures to derive an expression giving the relation between viscosity and specific

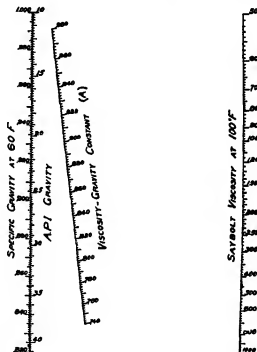

FIG 6

gravity for these oils. They found that the experimental data for each series of oils could be expressed by an equation

$$G = A + b \log(V + c),$$

where G = specific gravity at 60° F,

V = viscosity at 100° F Saybolt sec.,

A, b, c = constants for any one series of oils

Comparing the constants A, b , and c for each of the five series of oils, they found c to be -38 in all cases, and that the relation between A and b was

$$b = \frac{1.0752 - A}{10}.$$

Putting these values in the equation, we obtain

$$G = A + \frac{1.0752 - A}{10} \log(V - 38)$$

The oils in each of the five series will have the same value of A , which may therefore be taken as a measure of the quality of the oils in the series. A is called the viscosity

gravity constant (v.g.c.), and, rearranging the equation, we have

$$A = v g c = \frac{10G - 1.0752 \log(V - 38)}{10 - \log(V - 38)}$$

Values of A range from 0.807 for Pennsylvanian oils to 0.902 for Gulf Coast. It will be noted that in deriving the function the assumption has been made that all the oils derived from any one of the five crudes are equally paraffinic. This is not necessarily true for other crudes, and to this extent the v.g.c. scale is arbitrary, since, had it been founded on experimental results obtained from other crudes than those actually used, the equation for A might have differed from that given above.

The nomogram shown in Fig. 6 allows values of A to be obtained from the viscosity at 100° F [7, 1931]. Hill and Coats state that accurate values of the v.g.c. are not to be expected when the viscosity is below 47 sec Saybolt at 100° F.

In addition to the correlation between specific gravity and viscosity at 100° F, Hill and Coats correlated viscosities at 210° F and specific gravity for the same five sets of oils. One of the sets of oils (from Gulf Coast crude) was so much at variance with the others that it had to be discarded for the purpose of the correlation. The final equation obtained is

$$G = 0.24 + 0.755A + 0.022 \log(V'' - 35.5),$$

where V'' = viscosity at 210° F, Saybolt sec.

Values of A determined from this equation only agree approximately with those for the same oils from the equation using viscosity at 100° F. It is best to use this equation for viscosity at 210° F only for those cases where it is impossible to determine the viscosity at 100° F, satisfactorily.

A valuable property of v.g.c., and one which is much used in solvent refining, is that it is additive. Moore and Kaye [10, 1934] find that this does not hold for v.g.c.'s determined by Hill and Coats' formula at viscosities above 1,000 sec at 100° F. There is also the further difficulty that the original formula cannot be applied to oils of low viscosity. Moore and Kaye, who were particularly interested in the v.g.c. of Diesel oils, give the following formula in which the viscosity is expressed in centistokes, which they state agrees exactly with that of Hill and Coats over the viscosity range 50-1,000 sec Saybolt at 100° F, and which can be used satisfactorily at viscosities both above and below this range.

$$G = 1.082A - 0.0887 + (0.776 - 0.72A) \log_{10}(10\nu - 4),$$

$$\text{or } A = \frac{G + 0.0887 - 0.776 \log_{10}(10\nu - 4)}{1.082 - 0.72 \log_{10}(10\nu - 4)},$$

where ν = viscosity at 100° F centistokes

REFERENCES

1. DAVIS, G. H. B., LAPEYROUSE, M., and DEAN, E. W. *Oil and Gas J.* 30 (46), 92 (1932).
2. DEAN, E. W., and DAVIS, G. H. B. *Chem. Met. Eng.* 36, 618 (1929).
3. DOCKERTY, F., HANDS, C. H., and HAYWARD, W. A. *J.I.P.T.* 20, 248 (1934).
4. HERRH, R. E., FISHER, E. K., and FENSKE, M. R. *Ind. Eng. Chem.* 27, 1441 (1935).
5. HILL, J. B., and COATS, H. B. *Ind. Eng. Chem.* 20, 641 (1928).
6. HILL, J. B., and FERRIS, S. W. *Ind. Eng. Chem.* 17, 1250 (1925).
7. HOUGHTON, W. F., and ROWS, J. A. *Ind. Eng. Chem. Anal.* 3, 144 (1931).
8. LARSON, C. M., and SCHWARDENER, W. C. *Nat. Petr. News*, 24, no. 2, 26 (1932).
9. ———. *Nat. Petr. News*, 25, no. 19, 25 (1933).
10. MOORE and KAYE. A.P.I. 15th Ann. Meeting, Nov. 1934, Sec. 3, p. 7.
11. WATSON, K. M. *Oil and Gas J.* 33 (11), 33 (1934).

ANOMALOUS VISCOSITY

By A. S. C. LAWRENCE, Ph.D.
Laboratory of Colloid Science, Cambridge

The name *anomalous viscosity* is applied conveniently to the behaviour of certain systems—mostly colloidal—which do not obey the Poiseuille equation for flow through a tube. For normal liquids the volume efflux is given by the equation

$$V = \frac{\pi r^4 p l}{8 \eta}$$

where r is the radius of the tube, l its length, p the pressure head, t the time, and η the viscosity. Numerous cases are now known where the 'viscosity' calculated by the Poiseuille equation varies with the rate of shear, becoming very large with small values of p . Since viscosity is defined as the constant ratio of shearing stress to rate of shear, it follows that in the strict physical sense these variable values are not viscosities at all and that the name *anomalous viscosity* is a mutual contradiction. No better name, however, has been proposed, so it will be used in this paper together with the term *apparent viscosity* for the values obtained by misapplication of the Poiseuille equation to systems for which it does not hold. The German name of *structure viscosity* is equally offensive to the physical purist. It has the further drawback that the word 'structure' usually refers to a structure with some degree of regularity whereas the structure in these liquids is wholly disorganized and a result of mechanical interference rather than of regularly repeated attractive forces.

Poiseuille [13, 1846] deduced his equation from experimental observations on the flow of liquids through tubes. Fourteen years later Hagenbach and Ruckebacher [6, 1860] showed that the equation is a consequence of the parabolic velocity distribution across the tube postulated in 1713 by Newton. The velocity is zero at the wall and increases as the square of the distance from it. Where, therefore, the volume efflux does not bear a linear relation to the pressure head, the flow is not Newtonian—the velocity distribution is not parabolic. The flow is anomalous, not the viscosity.

The parabolic velocity distribution always holds in *laminar* or *Newtonian* flow. No case of wall slip has ever been detected. The constancy of the ratio of shearing stress to rate of shear has been established over a very wide range, for water an alteration of rate of shear by 10,000 times produces no change of η . For normal liquids there are only two types of flow, *laminar* and *turbulent*. Osborne Reynolds showed that if the rate of flow is large, steady laminar flow is disturbed and turbulence follows. He found that the onset of turbulence is approximately proportional to the pressure head according to the relation

$$R_e = \frac{v D \rho}{\eta}$$

where R_e is a dimensionless number usually named the Reynolds number, v is the mean velocity, D the diameter of the tube, ρ the density, and η the viscosity coefficient. R_e is from 1,400 to 2,000 for capillary tubes. Anomalous systems which have been examined at high rates of shear have low Reynolds' numbers [7, 1925, 1932].

The volume-efflux method can, as already pointed out, be used for detection of anomaly. The apparent viscosity

calculated by misapplication of the Poiseuille equation gives values which, as the pressure head employed decreases, increase often to very large values. The method, however, is not a good one owing to the practical difficulty of constructing a flow viscometer in which the pressure head can be varied at will and, at the same time, kept constant through an experiment. Bingham and Ostwald have described such viscometers [1, 12, 1930-5]. The ordinary Ostwald viscometer is unsuitable for detection of anomaly as the pressure head is not controllable nor does it remain constant during an experiment. The standard commercial viscometers are the worst type of all, except the MacMichael which is of the coaxial type (see later). In them the length of the capillary hole through which the liquid flows is not sufficient to ensure laminar flow and the pressure head is not under control. The result is that enormous numbers of measurements of viscosity, particularly of oils, have been made which are worthless, results obtained by use of different standard viscometers are not even strictly comparable. This situation is particularly unsatisfactory since it is in the cases in which viscosity is the most useful criterion of a product that anomaly is most likely to occur.

The best instrument for detection of anomaly is the coaxial cylinder viscometer usually called the Couette viscometer, after its designer. With this instrument the rate of shear is varied over any range desired by altering the angular velocity of the moving cylinder. This instrument has been used by a number of workers for detection of anomalous viscosity, in particular Hatschek whose book [17, 1928] should be consulted. For normal liquids, the viscosity is given by the equation

$$\eta = \frac{c \theta}{4 \pi l \omega} \left(\frac{1}{R_1^2} - \frac{1}{R_2^2} \right),$$

where c is a constant for the torsion wire, θ the deflection of the hanging cylinder, l its length, R_1 and R_2 the radii of the cylinders, and ω the angular velocity. It is clear that for two Newtonian liquids the deflections are directly proportional to the viscosity.

If anomaly exists, then results are of the form shown in Fig. 1

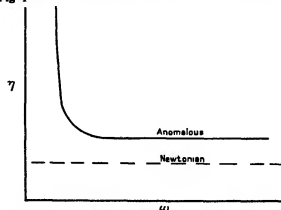

FIG. 1. Detection of anomalous viscosity by coaxial cylinder viscometer.

Rigidities may also be measured by this apparatus. When the torsion head is turned through an angle, the cylinder will follow if the liquid is Newtonian. If, however, rigidity is present it will turn through a smaller angle α only. The modulus of rigidity N is then given by the equation.

$$N = \frac{c}{4\pi} \left(\frac{1}{R_1^2} - \frac{1}{R_2^2} \right) \frac{\delta}{\alpha}$$

where δ is the difference between the two angles and c a constant for the torsion wire.

Maxwell pointed out that if a strain S is caused in an elastic body, a stress F results. Now if the body is viscous, then the stress will disappear at a rate which depends upon the value of F and on the properties of the body. Assuming that the rate of disappearance is proportional to the stress, we get

$$\frac{dF}{dt} = E \left(\frac{dS}{dt} - \frac{F}{\eta} \right)$$

In liquids η is small when very large we have the case of a solid.

Hatschek has observed the modulus of rigidity of some colloidal anomalous sols. The values are given in the following table.

TABLE I

	Modulus of rigidity, $\text{mg}/\text{sq cm}$	Apparent viscosity, centipoises
0.2% gelatin (24 hrs old)	0.87	
0.3% benzopurpurin	0.75	
1.0% "	11.1	297,300
0.2% ammonium oleate	2.29	52,200

The second column gives the apparent viscosity at a very low rate of shear, one revolution in about 180 hrs. It should be noted that "aging" occurs over long periods in all anomalous systems.

If the flow is anomalous then the velocity distribution is not parabolic. It has been suggested that a modified Poiseuille equation might be derived with an exponent for the velocity distribution less than 2. Then, from volume efflux measurements, its value could be deduced. However, this procedure was not successful. Measurements of the actual velocity distribution have been made now by several methods. That of the author is the most direct and involves least disturbance of the flow [14, 1935].

Liquid from two reservoirs flows through a tube, via a specially designed two-way cock, one supply being coloured so that its contour may be photographed as it advances in the colourless liquid and the velocity distribution across the tube found. Pchot and Dupin and Kroepelin measured velocity by putting in small particles. Richardson by an anemometer. The results can be shown best by plotting the velocity against the square of distance from the wall of the tube. Then for Newtonian flow a straight line is obtained, velocity being zero at the wall. With anomalous flow, marked deviations occur, see Fig. 2. The viscosity coefficient is the reciprocal of the slope (after allowing for the value of the pressure). The curves of Fig. 2 can be analysed by taking the slope at a number of points and thus calculating "viscosities" across the tube. Results calculated in this way from a number of experiments are shown

in Fig. 3. This figure shows the extreme complexity of anomalous flow.

This is probably the best approach to a purely physical treatment of anomalous flow but, for the chemist and colloid chemist, much more tangible results have been

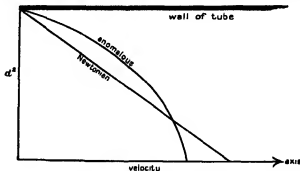

FIG. 2 Velocity distribution in flow through a tube of circular cross-section

reached by other methods. We can divide anomalous systems into the three classes

- one phase,
- colloidal solutions,
- two-phase systems

But this classification is not very helpful since the three classes are continuous and several of the anomalous systems—perhaps all—are anomalous just because they

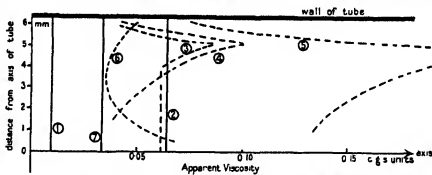

FIG. 3 Apparent viscosity distribution across tube of circular cross-section. Calculated from determinations of velocity distribution

are "border-line" cases. There seems to be one clear-cut single-phase case of peculiar viscosity, that of plastic sulphur. When sulphur is heated there is a sudden increase of viscosity at 168° C. [12, 1930-5]. Liquid crystals, perhaps, fall into this class, although they are certainly not homogeneous to all physical tests [2, 1933].

Anomaly occurs at critical separation of liquids. This is akin to the opalescence at the critical point of gases. Colloidal solutions are half-way between one- and two-phase systems. They are not homogeneous to many physical tests but they do not present an interface, solvent solute. Finally, we have those systems in which the disperse phase is quite coarse such as suspensions of clay and paints.

It is much more profitable to separate colloidal systems according to particle or molecular shape, into the two classes

- those in which the molecule, i.e. the kinetic unit in colloidal solution (it may be a giant polymermolecule

or an assemblage of molecules held together by van der Waals forces) is spherical or nearly so, and (b) those in which the micelle is a long thread, needle, or elongated plate. We will refer to these generally as 'anisodimensional'.

It is frequently suggested that homogeneity, in the sense of uniform distribution of the disperse phase, is an intrinsic property and, hence, a criterion of colloidal solution. This is quite untrue and gives a wrong perspective to the whole subject of colloids. Whether or not sedimentation occurs depends upon difference of density and extent of small external disturbing forces. Given a density difference and absence of disturbance, sedimentation occurs. The difference between a suspension and a true colloidal system lies in the presence or absence of free interfacial energy. The mechanism of the reduction of interfacial free surface energy is quite different in the two types of colloid, lyophilic and lyophobic, but that has nothing to do with the general principle. If the interfacial free energy is very small, then the system is a stable colloidal one, irrespective of whether the micelles of the disperse phase happen to be sitting at the bottom of their bottle or travelling about in the dispersion medium. The difference between true solutions and colloidal systems is that, in the latter, the particles are large compared with the size of ordinary molecules. In the early days of colloid chemistry, by a quite fortuitous chance, all the colloidal systems known had particle size very much larger than the biggest molecules. That gap has now been filled and there is continuous gradation from molecular solution to colloidal, nor is there an exact mass specification above which all is colloidal and below, all molecular. Different tests show the appearance of colloidal properties at different sizes. The ultracentrifuge can at the highest speeds cause sedimentation in molecular solutions. Optical, viscosity, and other tests of the colloidal state of dispersion are secondary properties in the sense that they require the participation of some other property of the micelle before any information can be obtained. For the property of anomalous viscosity the shape factor is the chief one to be considered after particle mass. The physical state of the individual micelles influences the nature of the anomaly, but this factor has hardly been considered yet.

The micelle is a discrete particle to be considered objectively—large enough to exhibit all the properties of matter in bulk and large enough no longer to behave with the freedom of the kinetic units in true solutions. All types of anomalous viscosity are a direct consequence of mutual mechanical interference of micelles. Adhesion of micelles may occur when they touch so that they are locked into a rigid body, but this effect is secondary to the interference which is due to shape and size only.

The first attempt to deal with the viscosity of colloidal systems was the Einstein equation for systems containing spherical particles separated by large distances (i.e. low concentrations) $\eta_s = \eta_m(1 + 2.5\phi)$, where η_s and η_m are the viscosity of sol and dispersion medium, and ϕ is specific volume of solute.

This equation, however, does not help with anomalous viscosity since the anomaly is due to interference of micelles. It will be observed that according to this equation, the viscosity is independent of the degree of dispersion. Attempts were made to apply this equation to hydrophilic systems which did not conform to its postulates with the idea of calculating effective micellar dimensions which would include a solvation layer around them. The

whole problem of the viscosity of lyophilic systems remained obscure until two points were recognized that many of the values described as 'viscosities' were not true viscosities and the work of Staudinger gave us a true picture of the constitution of these systems, and of the importance of the anisodimensional micelle. We are still without a complete theoretical treatment of anomalous flow [8], but this difficulty can be evaded in many cases by use of Staudinger's methods (see below).

Before discussing Staudinger's work, Bingham's conception of plasticity must be considered. He was concerned mainly with pastes in which the particles are isodimensional. His systems fall outside the Einstein equation only by reason of their high concentration of disperse phase. They include clay pastes, mud-pies, paints, and similar systems. Colloidal solutions lie outside this ideal. For example, sols of TiO_2 have been prepared containing 64% of TiO_2 , but, as the micelles are not anisodimensional, the viscosity is normal. The micellar weight is about 10^6 . Sulphur sols containing micelles of the same size also behave as Newtonian liquids.

Bingham uses the reciprocal of the viscosity coefficient in place of the more usual viscosity. For normally flowing liquids he has established useful relations, including a method for detection of association. His work in the field of anomalous flow has been mainly upon thick pastes, that is, systems in which the disperse phase is composed of isodimensional particles and whose concentration is great. Fig. 4 shows the basic idea. The curve *AB* represents the relation between flow and pressure head applied. The point *B* is therefore the yield point of the system. In practice, however, such a straight-line relation is rarely, if ever, found. Deviations occur both at high and low pressures. It is extremely difficult to be certain whether

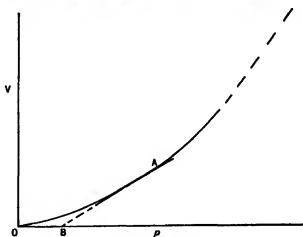

FIG. 4. Plastic flow.

or not there is a very small yield point, but it is clear that in most systems the curve bends round and passes either through the origin or very close to it. At higher pressures the curvature continues to increase. It thus appears that the procedure of drawing a straight line through a few points will give a fictitious yield point and that, if the upper part of the curve is complete, any number of yield points can be obtained by drawing tangents to the curve at different points. Actually this procedure may be useful since it gives an indication of the 'body' of a paste at the desired shearing pressure.

The flow of clay pastes can be divided into stages

First, flow occurs as a plug lubricated by the film of liquid at the wall. Volume efflux is proportional to pressure at this stage. With increase of pressure, volume efflux rises more rapidly owing to shearing of the plug progressively from the outside. When the pressure is sufficiently large shearing occurs right across the tube. This analysis illustrates well the fundamental difficulty in the study of anomalous flow, that there is always a shearing gradient so that in some parts of the tube flow is anomalous and in others Newtonian. The rate of shear is greatest at the wall and smallest at the axis. This fact accounts for the general absence of adhesion to the walls.

Freundlich [3, 1935] has shown that as soon as the particles in pastes become non-spherical, peculiarities appear.

Briefly, Staudinger's ideas are that long chain molecules are particularly active in increasing viscosity, that they are a cause of high viscosity in solution, owing to their filling by rotation normal to long dimension effective volumes much larger than their actual volume and, therefore, larger than that of a particle which is spherical or nearly so. The specific increase of viscosity caused by these anisodimensional particles (molecules or micelles) is a linear function of the particle length, but results are obviously only strictly comparable among systems of similar cross-dimensional structure, e.g. homologous series or polymer-molecule series. By measuring viscosities of solutions of the lower members of any series whose molecular weight is known, that of higher unknown ones may be calculated. The assumption is made that the main motion of the particles is the rotation normal to long dimension which introduces an error of unknown magnitude since the random translational motions will be much more important in the lower fiducial substance than in the really large ones whose molecular weights are unknown but of the order of 10^6 or 10^8 .

A further error is introduced by the fact that a very long molecule tends to assume a spiral form as a result of energy considerations. The shape will still be anisodimensional but a numerical correction will be required. It may be noted that this spiral form can be used to explain the elasticity which is found in sols such as ammonium oleate.

Staudinger's full picture of solutions of anisodimensional particles is summarized in Fig 5. As concentration increases there will be reached a point, P , where the total effective volume of the particles is equal to the total volume of the solution, $v = n(l/2)^3\theta$, n particles of length l and thickness θ being dispersed in a volume v . Further increase of concentration must mean restriction of their movements, more interference and therefore an increased dv/dc . Flow is still Newtonian. This transition point is quite sharp and can be used as an alternative to the first method for determination of particle size. When concentration is still further increased the interference of the particles will be progressively greater until the solution has an effective sponge structure throughout. The viscosity will have become anomalous before this, but there can be no definite point at which anomaly appears since the persistence or absence of anomaly will depend upon the deforming force applied. Ultimately, however, the solution will form a gel, that is when the structure has attained the quite arbitrary shear strength required to support its own weight against the deforming force of gravity.

It should be noted that gelation may occur without preliminary anomalous viscosity. Hatschek quotes, lithium

urate and the author's observations on sodium benzoate in a mixture of alcohol and water shows it to be of this type. In these cases the habit of the crystals is very fine needles. Gelation is here no more than a peculiar type of crystallization. Such gels will never be stable as crystal growth occurs and syneresis follows. In this class are also camphorylphenyl-thio semicarbazide and Hardy's 5-dimethyl-amino-anilo-3,4-diphenyl-cyclopentene-1,2-dione in organic solvents, and the precipitate type of gel formed by metathesis, such as manganese arsenate [9, 1935]. During coagulation changes there is always a powerful tendency to formation of chains of particles.

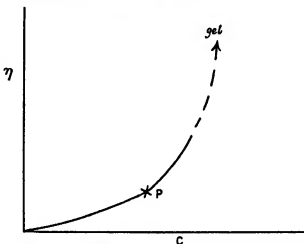

FIG 5 Relation between viscosity and concentration for solutions of macromolecules or micelles. The broken line represents anomalous viscosity.

The peculiar value of Staudinger's work in unravelling the problem of anomalous viscosity is that any system showing anomalous flow can be diluted until flow is Newtonian and the curve of Fig 5 mapped out and valuable data obtained.

The nature of the anomaly observed in any particular system will depend upon the physical properties of the particles. We have a whole range from very soft, such as ammonium oleate, to fully crystalline hard rods, such as V_6O_8 . The results are what might be anticipated by analogy with gross systems familiar to every one. Even in a mass of tree trunks floating down a wide river there are the beginnings of interference and structure. As the particles become finer we have wools of various physical properties from glass wool to the finer more flexible animal and vegetable wools. Many organic substances crystallize in very fine needles intertwined in such fashion that they hold large volumes of water mechanically. Benzo-purpurin is a good example. Some are so fine that it is difficult to decide whether they are gels or not. In true gels the state of dispersion is very high. In general they are optically empty when first formed. But gelation is essentially a particle growth phenomenon. In many cases it seems that a crystallization either of molecules or of micelles takes place to form larger particles which, although still very small, thus gain the necessary rigidity. Anomaly occurs in emulsions but is due to distortion of the droplets of the disperse phase. The anomaly is independent of its bulk viscosity [15, 1930]. The droplets are deformed into filaments and the free interfacial energy increased. The phenomenon is therefore primarily one of surface tension.

When the concentration of the disperse phase is increased still further, a system is finally reached in which a solid body is obtained, which, however, may retain the characteristic shape of the micelles and in consequence still shows anomaly. Even where there is no definite continuity or where the shape of the micelles in the anomalous sol is not clear, the solid will probably not be fully crystalline. Of the first type the soaps are characteristic and of the second, gelatin. Pitch is intermediate between the two in that it is probably a solution but without a definite shape to the particles of the disperse phase. Vaseline is a three-component system. It flows under sufficient pressure but it has a yield point sufficient for small masses to retain their shape under gravity. If examined in polarized light with crossed nicols, numerous little crystalline plates are clearly visible. But if the cover-glass is moved about it becomes evident that these tiny crystalline plates are not the cause of the anomaly and that they are only 'passengers' held in some colloidal structure. The correctness of this view is proved by the work of Gurwitsch [5, 1932] who found that he could filter off the crystals and that the filtrate showed all the original anomaly of flow. Attempts have been made to find a relation between viscosity coefficient and temperature. If, however, we examine a homologous series in corresponding states, e.g. the saturated hydrocarbons at their boiling-points, it is found that the viscosity is independent of chain length. In other words, such a relation gives the distance from the critical point, a property that can be calculated more accurately by other methods. The temperature coefficient is, however, of considerable practical importance so that the factors underlying it need attention. Silverman has started from the idea of loose aggregates in liquids, and from the temperature coefficient calculated the energy of dissociation of the groups. This idea is of great interest since it brings normal liquids into continuity with anomalous liquids. The sole difference is in the binding of the aggregates. The temperature coefficient should therefore be useful for indicating the nature of association in liquids of unknown constitution such as lubricating oils. There are several possibilities. Loose aggregates as in normal liquids giving a normal temperature coefficient. Polymer-molecules which are not altered in size by temperature changes and therefore have a low temperature coefficient. Micelles in which the molecules are held together by van der Waals forces have a very large temperature coefficient over a certain range. However, polymer-molecules may themselves form larger groups which will break down with a high temperature coefficient. Insufficient attention has been given to the nature of the temperature variation of anomaly as a method for correlating physical change in the micelle with bulk anomaly of flow. In the case of soap-oil systems, the rigidity is parallel to phase changes in the soap.

For successful lubrication, two qualities seem to be required, *oiliness* and *body*. *Oiliness* is a consequence of the shape of long-chain hydrocarbons. Adhesion to the surface to be lubricated is essential, and we know from Hardy's work that this is due to the presence of molecules with terminal polar groups such as the fatty acids. It is now well established that there is no orientated layer growing out for any distance from the primary adsorbed layer in normal liquids, although in colloidal solutions wall adhesion has been found occasionally.

Body is the hypothetical quality which distinguishes a lubricant which remains good at high temperatures from

those which deteriorate. It is not directly connected with viscosity. Is it anomalous viscosity? Or rather, is it due to the same cause as anomalous viscosity? It is claimed that greases retain their 'body' at high temperatures. Greases are good examples of anomalous viscosity. They are said to be colloidal systems, water-in-oil emulsions. However, the writer's work (in press) suggests that this is not correct but that the water is present as water of hydration and affects only the habit of the soap as it crystallizes out from the oil. In the presence of a little water, the soap separates in anisodimensional fibrils. The system is crystalloid and the gelation a morphological phenomenon, not a colloidal one at all. The water has a second function, that of lowering the dispersion temperature. Soap in oil is not dispersed since the oil can penetrate only between the hydrocarbon chains of the soap molecules to a limited extent (Fig. 6). A little swelling occurs but the oil cannot rupture the adhesion of the polar groups. The mixture needs to be heated to the temperature at which thermal disruption occurs, that is, the melting-point. If, now, a little water is present this adhesion is lowered and, consequently, the melting-point and the dispersion temperature in oil. The phenomenon is seen in solutions of barium oleate in toluene. It is quite insoluble if the toluene is dry, but addition of a small amount of water at once makes it soluble and the barium oleate can be crystallized. If more water is added, huge solubilities can be obtained but the resulting mixtures are not emulsions.



Fig. 6

In connexion with lubrication, there is one more type of anomalous flow which should be considered. *Smectic* liquid crystals are solid in two dimensions and liquid in the third. They therefore have a layer structure in which each layer is a solid which can slide over its neighbours as a liquid. In mass any such system is made up of a large number of groups of such sheets, each group with its own orientation. In flow, they gradually take up a common orientation, and when that is reached the viscosity is at a minimum and that of a liquid. Whether analogous systems exist in lubricating oils is not known, but it is suggestive that there is some connexion between wax content and polymer content.

In addition to mechanical anisotropy, a number of colloidal systems show 'streaming double refraction'. At rest these are isotropic, like ordinary liquids and solutions, but when flowed through a tube, or in a Couette apparatus, they become birefringent. The analogous case in solids—mainly colloidal substances—of strain birefringence has been studied extensively. Two cases have to be considered. True strain birefringence—that is, change of optical density due to the straining of the bonds in the solid, and, secondly, orientation birefringence, that is, the taking up of a common orientation by a number of units in the substance as a result of the deformation caused by strain. In liquids we are mainly concerned with the latter, since the yield point of anomalous liquids is too small for the first

type to appear. There are, however, two causes of orientation birefringence. First, exemplified by aged sols of vanadium pentoxide, in which flow causes orientation of the micelles, which are long needle-shaped crystals. The streaming birefringence is then the sum of the intrinsic birefringences of the crystals. This has been confirmed by Freundlich [4, 1935].

In general the observed cases are much less simple than this one. Birefringence may also be caused by common orientation of rod-shaped particles small compared with the wave-length of light. This is known as Wiener's birefringence. The result is similar to the first type in that the liquid behaves as a positive uniaxial crystal.

of isocline of 90° . Young V_2O_5 sols have an angle of isocline of 45° , aged ones 90° .

In conclusion, it is clear that anomalous viscosity is not an absolute method for determining particle size. Nevertheless, where anomaly does occur, it is a proof of combined large size and anisodimensional form. We also know that of the lyophobic colloids a very large number are of the type in which the micelle is a polymermolecule and that these polymermolecules frequently have an elongated form. Attention needs to be given to the influence of the rigidity of the particle upon the mechanical properties of its sols. We know that the linear polymer in which there is free rotation at the bonds will assume a coiled form. Sulphur

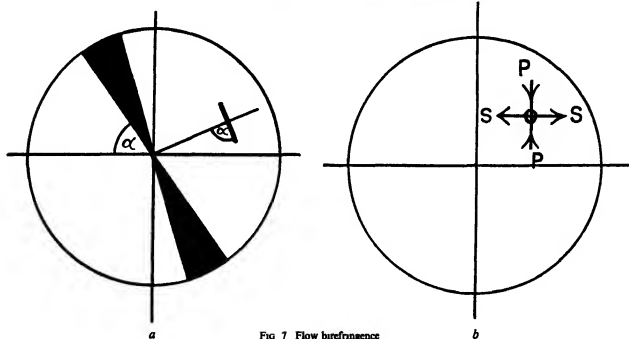

FIG 7 Flow birefringence

A simple method of studying streaming double refraction is by examination of the liquid in a coaxial cylinder apparatus in converging polarized light. When one cylinder is rotated the brush characteristic of uniaxial crystals appears. Stokes has shown that if now we consider an element of the solution at O (Fig 7b) then the shearing forces acting on it may be represented as a pressure PP and a tension SS . The consequent elastic deformation will cause birefringence. It is obvious that the resultant double refraction will have its optic axis along SS since both forces taken separately would produce this result.

The position of the brush with respect to the planes of polarization will depend upon the position of this optic axis. The name 'angle of isocline', α , is given to the larger of the two angles between the brushes and the planes of polarization. This is also equal to the smaller of the two angles which the optic axis of an orientated particle makes with a radius drawn through it (Fig 7a). Complete orientation of the particles along the stream-lines will produce angles of isocline of 90° . Possible angles of isocline obviously vary from 90° to 45° . It must be emphasized, however, that this method gives the orientation of the optic axes of the particles which is not necessarily the geometric axis. In V_2O_5 the two are nearly coincident so that complete orientation of the needles along the stream-lines means also orientation of the optic axes and an angle

is an example [11, 1935] and some workers have claimed that rubber is also. In rigid colloidal systems, it is possible that in many cases there is not free rotation, that some degree of crystallization of the primary micelles occurs to form a unit of structure. This seems to occur in such sols as gelatin where no anomaly occurs at temperatures above $42^\circ C$. The sodium soaps (unpublished work of the author) owe their gel-forming properties to the morphological peculiarities of the $COONa(H_2O)_n$ crystals.

Finally, the picture drawn of anomalous viscosity and gel structure makes it clear why marked 'ageing' effects are so frequently found—when sought—and suggests that such effects in many cases will continue for very long periods at a slow rate, since the rate of attainment of a final state is retarded by the very factor—interference of micelles—which is responsible for the anomalies observed.

When anomalous viscosity was first observed, it was recognized that there was a connexion between the phenomenon and particle shape. There is, however, no reason for rigidity in cases where no adhesion of particles exists. A completely lyophobic particle, however large, may pass Staudinger's critical concentration, but specific adhesion is necessary for gelation. Obviously, if this exists, gelation will occur at a concentration very much smaller for anisodimensional particles than for spherical ones. To bring these forces into operation requires supersaturation of the

solution either by altering the electrical properties of the surface of the micelle in the case of lyophobic systems or by cooling or salting out a lyophilic one. Examples of the first class are gelation of alumina sol by addition of ions or destruction of adhesion of zinc oxide paste in paraffin by addition of an oil containing a polar group. In the second class it is obvious that the substance should not have a well-developed crystal habit, examples are gelatin, agar, the soaps.

It is easy to see that a random arrangement of threads can bind itself into a sponge-like structure, especially if the binding forces come into operation suddenly. The threads may be micelles or large molecules. A large molecule of the irregular shape shown will 'crystallize' in the necessary structure and not in a regular crystal habit. It is therefore to be expected that gelling substances will in the solid state lack full crystalline form, e.g. gelatin. There is the distinction between micellar and molecular colloids that the former can undergo rearrangement into another crystalline form which is not necessarily a thread-like one and gelation may be lost on further cooling. The soaps show this phenomenon in both aqueous and oil solution. Potash soaps incorporated in oil have, at room temperature, no rigidity; they are pastes of small crystals. On heating to about 130°C they swell and gelate. On further heating they become isotropic solutions at 230°C. The special lubricating value under heavy load of oils containing soap is therefore restricted to a limited temperature range. It follows also that the consistency of the mixture

at room temperature is not a direct guide to its 'body' at higher temperatures, except in so far as the crystals deposited from a gel will be smaller than those from a solution.

Thixotropic gels are a special case in which adhesion of the particles of the gel structure is so weak that shaking breaks it down to a sol which, on standing for some time, resets. Thixotropy seems to be due to the anisodimensional form of the particles. A plastic paste of spherical particles has a yield point but no relaxation time. A thixotropic system requires time for the particles to recover a random orientation. Under Brownian motion, the particles will be moved preferentially at right angles to their smaller dimensions. Long thin plates should therefore show thixotropy better than rods. It may be noted that Bentonite is a substance of this habit.

In conclusion, it may be noted that the nature of anomalous viscosity—greatest anomaly for smallest rates of shear—is explained by the smallness of the adhesive forces acting at occasional points of contact. If no adhesion occurs but the particles are very large, we should expect large but not anomalous viscosity. Maximum viscous anomaly is shown by the most completely random distribution orientation by flow is accompanied by progressive disappearance of the viscous anomaly. When rod-shaped particles are all orientated along the stream lines, the streaming birefringence of the liquid is at its maximum, but interference with normal hydrodynamical flow is at its minimum.

REFERENCES

- BINGHAM, I. F. *Fluidity and Plasticity*
- Faraday Soc. Report*, 1933
- FREUNDLICH, H. *Trans. Faraday Soc.* 1935
- *Science Progress*, Oct. 1935
- GURWITSCH, L. *Scientific Principles of Petrol Techn.* 2nd English ed., trans. Moore, H., 552 (1932)
- HAGENBACH, E. *Pogg. Ann.* 109, 385 (1860)
- HATSCHKE, E. *Koll. Z.* 39, 300 (1926); ANDRADE, E. N. da C. *Koll. Z.* 28, 261 (1926); OSTWALD, W. *Koll. Z.* 60, 159 (1932)
- KUHN, W. *Original papers*
- LAWRENCE, A. S. C. *Proc. Roy. Soc. A*, 148, 59 (1935)
- MANNING, A. B. *Proc. World Petr. Cong.* 1933, reprint 199
- MARK. *Faraday Soc. Report on Polymers*, Oct. 1935
- OSTWALD, W. *Koll. Z.* 1930-5
- POBBEILLE. *Mémoires Savants Etrangers*, 9, 433 (1846)
- Proc. Roy. Soc. A*, 148, 59 (1935)
- SHREVE, J. O. *Trans. Faraday Soc.* 26, 26 (1930)
- STAUDINGER. *Trans. Faraday Soc.*, and numerous original papers in *Ber. und Helv. Chim. Acta*

SELECTED BIBLIOGRAPHY

- HATSCHKE, E. *Viscosity of Liquids* (1928)
 BARR, G. *A Monograph on Viscometry*
 FREUNDLICH, H. *Thixotropy* (1936)

THE MEASUREMENT OF PLASTICITY

By A. de WAELE, F.I.C., F.Inst.P.
Director of Research, D Gestetner Ltd, London

It is somewhat surprising that although no very general agreement seems to have been arrived at to interpret scientifically the designation 'plasticity', its conception as a certain state of matter is familiar to all. The writer proposes to employ the term plasticity to cover those properties of certain materials, intermediate in their shear behaviour between solids and liquids, which in a more complex form correspond to viscosity in true fluids.

Whilst it is beyond the scope of this article to deal with the subject of plasticity in the comprehensive manner which its importance warrants, a brief outline of the characteristic properties of plastic bodies will be necessary.

The 'consistency' of a true fluid is completely defined by its viscosity, or the shear stress necessary to set up unit velocity gradient when applied to parallel planes unit distance apart. This consistency or viscosity is a constant of the material up to fairly high limits of velocity gradient, so that the constant may be determined over wide limits of the variables. The consistency or apparent viscosity of plastic substances (e.g. pastes, greases, &c) shows, however, the paradox of diminishing with the stress applied, and therefore involves a sufficient number of determinations of rates of shear, under varying shearing stresses, to establish the manner in which these two variables are connected. This is made apparent in Fig 1, where the stress/volume

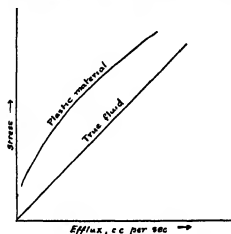

FIG 1 Variability of consistency with rate of shear of a plastic substance

velocity of efflux graphs of a fluid and a typical plastic are compared, the data having been obtained from an efflux viscometer in which varying pressure could be applied. The extrapolated (dotted) line from the curved line indicates immediately a characteristic difference between the two systems to be anticipated from their known properties. Thus whilst the straight line representative of the fluid extrapolates to the common origin, indicating some degree of flow, however small, for all applied stresses, the point of origin of the curve of the plastic substance indicates the existence of a rigidity, yield value, or 'stayeredness' (to employ an Americanism) typical of a solid substance.

The curve of the plastic substance, moreover, shows a diminishing graphical curvature as the stress and corresponding shear are increased, without, however, in the example shown, reaching absolute linearity. Assuming that such linearity is eventually reached, it would appear that a practical evaluation of the consistency of plastic bodies might be obtained by recording the extrapolated intercept and the limiting viscosity at high stresses, thus again indicating such bodies to be hybrid solid-liquid complexes, tending in their properties towards the one or the other state according to the magnitude of the disturbance set up within them.

To a first approximation, and bearing in mind certain necessary precautions to be taken in interpretation of the experimental data, the characteristics of plastic bodies may be taken as definable by viscosity and the rigidity interpreted as this intercept. To those who are interested in the more exact study of plastic flow, attention is directed to the references at the end of this article, but it is necessary to remark at this point that our knowledge of the subject is confined to the effects of tangential stresses only, such as are applied in all forms of viscometer, whether of efflux or rotating type, and that little that is definite is known as to the mechanism when other than strictly tangential stresses are applied, e.g. the falling sphere instrument.

Whilst it would at first sight appear that any form of apparatus capable of equating stress and resulting disturbance would serve to evaluate the component constants of plasticity, the following factors must be considered as necessary to obtain correct and reproducible data:

- 1 The disturbance set up must consist in tangential flow of layers of the material past one another (orderly or stream-line flow)
- 2 The relationship between such tangential shear and the stress applied varying with the rate of shear (Fig 1), and the existence of an inertia, rigidity, or yield value being characteristic of the plastic state, the relationship between stress and shear must be explored over a sufficiently wide range to include the destined conditions of application
- 3 Apart from the necessity of adequate arrangements for measuring or recording the independent and dependent variables, instrumental defects, such as kinetic energy effects, accumulation of heat resulting in the energy of shear, &c, must be eliminated as far as possible

The types of instrument that have been proposed or have been in common use for the investigation of the behaviour of plastics under shear comprise:

- 1 The various forms of penetrometer
- 2 Rotating cylinder instruments.
- 3 Parallel plate viscometers
- 4 The falling sphere instrument
- 5 Capillary efflux instruments.
- 1 Penetrometers. These instruments, which have long been familiar to grease technologists, either measure as a single characteristic of the plastic substance the rate of

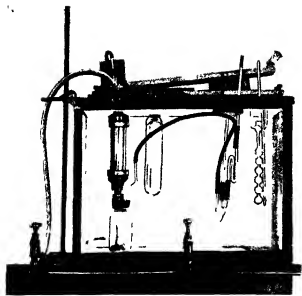

FIG. 3 Lay-out of thermostat

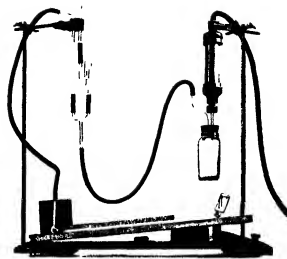

FIG. 4



FIG. 5

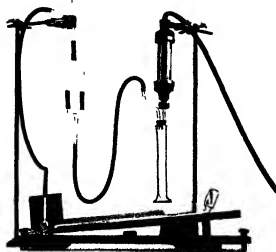

FIG. 6 Apparatus for standardizing flow meter

penetration of a cylinder or cone, or record the eventual depth of penetration under a given load. It is obvious that whilst the first method would fail to distinguish between a viscous (true) fluid devoid of rigidity and a plastic body, the second would but register rigidity. The above forms of instrument may therefore be considered to serve only as rough sorting tests.

2 Rotary Cylinder Instruments. In these the plastic material is contained between two concentric cylinders, one serving as a rotor and the other as a stator. In one form (McMichael, Couette) the outer cylinder is driven at a determined rate and the resulting torque due to consistency is measured by the deflexion of the inner stator suspended on a torsion wire. In the Stormer and in the newer Kampf instruments the inner cylinder is rotated by a falling weight attached to a string passing over a pulley, and the velocity of rotation is measured. The difficulties in maintaining a constant volume of sheared material immediately between stator and rotor during operation, and in securing a complete shear in the couple, together with the impossibility of dissipating the heat of shear, have precluded the use of these instruments for any but materials of very low degrees of plasticity (rigidity). What promises to be a great advance in construction on the instruments just described is the coneylindrical viscometer of Mercier [70, 1932], described by Mooney and Ewart [29, 1934]. In this instrument, which operates on the same principle as the Stormer viscometer, the 'end effect' causing non-laminar flow at the bottom edges of the couple, and the correction of which has only been possible in the Couette instrument when used with liquids, is eliminated by an ingenious design of the bottom of the inner cylinder.

The recent Kampf viscometer [25, 1930, 28, 1932] is also a rotating cylinder instrument of the Stormer type constructed to minimize considerably the friction of the latter apparatus.

3 Parallel Plate Viscometers. Although the parallel plate viscometer has been one of the earliest instruments described to measure the plastic properties of very stiff materials, its adoption for the evaluation of the softer plastics does not seem to have been general. Its main use in its various forms would appear to be for measurement of the plastic properties of rubber. The reader's attention is directed to Houwink's recent book on resins (including thermoplastics) [24], wherein the instrument is described and its application given in detail.

4 The Falling Sphere Instrument. This apparatus is mainly applicable to fluids and pseudo-plastic substances or non-Newtonian fluids, i.e. materials outwardly manifesting the physical properties of fluids in possessing no rigidity, but showing dependence of viscosity on the rate of shear. It merely consists of a small sphere (e.g. steel ball from a bearing), the rate of fall of which is observed through a column of the material. Little is known of the hydrodynamics of the method, the basis of which is due to Stokes, who showed that the viscous force opposing the motion of a sphere freely falling in a large volume of liquid is equal to $6\pi\eta rV$, where r = radius, η = absolute viscosity, V = velocity. Nevertheless, by the use of a number of balls of similar material but of varying radii, any variation of viscosity with rate of shear may be determined [85, 1931].

5. Capillary Efflux Instruments. In the simplest form of efflux viscometer as represented by a vertically disposed pipette or a Redwood viscometer, viscosity is measured by determining the time of flow necessary to deliver a given volume. It is clear that here the hydrostatic pressure

setting up the shear stress in the capillary orifice varies from a maximum at the commencement of the measurement to a minimum as the container empties. Apart from the obvious fact that the construction of such apparatus does not permit of use with a material other than a freely flowing liquid, the fact that in the case of plastics there is an apparent variation of viscosity with rate of shear makes it desirable that an instrument be adopted which permits of an accurate application of a constant pressure and corresponding recording of the rate of efflux, as distinct from the average value accruing from this simple efflux instrument. It should, however, be remembered that in any efflux type of instrument the shear stress applied to the fluid varies from a maximum at the walls of the capillary to zero at the centre.

Consequently, plastometers have been constructed which permit of the measurement of the rate of shear at any given pressure in excess of that needed to overcome the rigidity characteristic of the minimum critical shearing stress or rigidity of the material. Furthermore, the difficulty of observing the rate of efflux by drop in level in the container in the case of semi-rigid bodies is overcome by actually measuring the velocity of efflux from the capillary.

The first attempt to construct an efflux instrument capable of serving as a variable pressure capillary viscometer adapted for semi-solid bodies is to be attributed to Bingham and Green [5, 1919], who must be regarded as the pioneers of plastometric evaluation. The apparatus of Bingham and Green forms the basis of the one used by the present writer, who introduced a few simple modifications destined to permit of the instrument being used for routine use in a works laboratory.

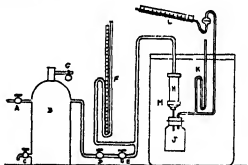

FIG 2 Diagram of plastometer

A description of the plastometer constructed and used by the author will make the application of these principles clear. Fig 2 shows a conventional diagram of the apparatus. In Fig 3 is shown the actual lay-out of the thermostat, Fig 4 the container, capillary, receiver, and air-leak.

- A = Main compressed air inlet valve from rotary compressor or oxygen cylinder
- B = Compressed air stabilizer
- C = Drain cock
- D = Compressed air control valve for regulating shearing pressure
- E = Compressed air relief valve for regulating shearing pressure
- F = Mercury manometer, preferably dual form, reading to 300 cm
- G = Safety valve
- H = Container for plastic material
- J = Receiver bottle.

- KL* = Flowmeter, comprising
K = Capillary air-leak,
L = Paraffin manometer
M = Thermostat vessel

Notes on the Apparatus

The equations connecting shearing stresses applied and resulting velocity gradient are based on assumptions that certain theoretical conditions shall be conformed to

1. Capillary Dimensions.

a The pressure applied is to be entirely lost in overcoming the shear which is calculated from the dimensions of the capillary. Thus, the extruded material continues in stream-line flow for an indeterminate distance from the end of the capillary depending on its dimensions, and in order that this extra flow may be restricted to within 1%, the ratio of length to radius should be at least 100.

b The available energy at the exit end of the capillary should be nil, i.e., the kinetic energy should be zero. Since the total pressure $P = P_s + P_k$ where P_s is the pressure used in shearing and P_k is that part used in producing kinetic energy, the latter should be minimum. In order that P_s/P_k should be less than 0.01, Q^2/P must not exceed the value of

$$\frac{\pi^3 R^4}{100 \rho^2}$$

where Q is reckoned in c.c. per second, P the pressure in cm of Hg, R the radius of the capillary in cm. Thus with capillaries of radii 0.1, 0.15, and 0.2 cm the limit for values of Q^2/P (c.c. per sec and cm Hg) should not exceed the respective values of 0.132, 0.666, and 2.11.

c *Turbulence*. The Reynolds number giving the critical value above which turbulence enters, is given as

$$\frac{vR\rho}{\eta} \approx 1,000,$$

where v = maximum velocity in tube of flow. As no data is available as to commencement of turbulence in other than Newtonian (true) fluids, and it has been suggested that turbulence in disperse systems commences at lower values than 1,000, velocities of efflux should be preferably kept as low as possible by maintaining the radius of the capillary as small as is compatible with experimental expediency.

d Under ordinary conditions of plastometric practice, wherein P is limited to not over 300 cm Hg and L/R of the capillary to about 100, no sensible rise of temperature of the contents of the capillary during shear is developed, and errors due to this source need therefore not be anticipated.

2. Manometers.

a The dimensions of the bulb and inclined tube in the flowmeter manometer should be such that a negligible difference in pressure results from the travel of the liquid up 20 cm. of the tube. The internal diameter of the latter should permit of an easy read hemispherical meniscus being formed by the liquid (paraffin oil), e.g. 2 mm. The scale is conveniently made movable in order to adjust the zero point.

b. The high-pressure manometer is preferably of the dial type, as pressures corresponding to 300 cm Hg do not permit of the installation of a hydrostatic manometer. In order to be able to carry out determinations at pressures

below the graduations of the dial manometer, additional mercury and water manometers reading to 100 cm should be fitted in parallel.

3 The dimensions of the glass air-leak determine (together with the inclination of the recording flowmeter) the sensitiveness of the instrument. Suitable dimensions used in the writer's apparatus are radius 0.045 cm, length 33 cm.

4 *Thermostat*. A large accumulator jar filled with water provides a simple thermostat bath. An adequate stirrer and constant temperature regulation to $\pm 0.2^\circ \text{C}$ are necessary. The regulation of the temperature is provided by a carbon filament lamp in connexion with one of the numerous enclosed mercury make-and-break devices now on the market.

5 Special attention should be paid to the tightness of joints. Flexible connexions should be made with rubber canvas-inserted tubing attached by means of 'Jubilee' clips. In practice the plastic material is contained in a lead colour-tube *A* (Fig. 5) by carefully filling in small quantities at a time and tapping down on to a rubber mat to expel entrapped air. The colour-tube then engages with the lower part of the container, by its threaded nozzle, and the whole container is assembled with its capillary by means of coarse threads and suitable rubber washers. The apparatus is then fitted up as in Fig. 3.

Compressed air is then admitted into the container to obtain such pressure as will record a maximum reading of 20 cm on the flowmeter manometer. The pressure is adjusted to a suitable value by the judicious use of valves *D* and *E* (Fig. 2).

A steady flowmeter reading having been obtained, further readings are taken at successively lower pressures by releasing air from the container by means of the relief valve *E*. A series of readings are thus taken until flowmeter readings become too low to be observed, and the results in terms of cm flowmeter are plotted against cm Hg pressure. The zero of the mercury manometer (*F*, Fig. 2) is adjusted to an amount corresponding to the mean hydrostatic head of the plastic material from the top level in the container to the lower end of the capillary.

The flowmeter is standardized by the obvious method shown in Fig. 6, wherein castor oil is extruded at three or four different pressures into the graduated measuring cylinder set in place of the usual receiver bottle when c.c. per second are then correlated against cm flowmeter. The results when plotted should naturally present a straight line extrapolating to the common origin of the axes.

The plastometer may equally be used for recording very low rates of shear indeed by plugging the air-leak and noting the velocity of rise in the liquid in the flowmeter, standardization being effected as in the manner previously described for the flowmeter with the open air-leak.

An attempt at a simplified form of capillary plastometer devised by Bingham and Murray [7, 1923] has been used by several investigators as involving a less expensive and cumbersome apparatus than the one described. It essentially has for its basis the recording of the rate of travel of an advancing meniscus of plastic material along an empty capillary tube, the shearing pressure being maintained constant. Owing to the increasing stress consequent on the increasing length of material in the capillary tube at any given moment, shearing stress diminishes accordingly. One is thus enabled, by noting the velocity of travel at different intervals of time, to formulate a series of read-

ings of velocity of shear against stress Unfortunately the instrument does not lend itself to the measurement of flow at the very high rates of shear demanded by the attainment of a high degree of deflocculation within the capillary, and some investigators using this apparatus have in consequence been misled into interpretation of the data to false values which were strongly influenced by the restrictions imposed by the apparatus used

A novel form of capillary plastometer employing very high rates of shear indeed has been described by M. H. Arveson [44, 1932] In this apparatus the rate of shear is made the independent variable, and the resulting stress is recorded as a pressure The apparatus employed is somewhat costly, but permits of exploration of a range of stresses that has not been attained hitherto in any other apparatus (It is unfortunate that the data appended by the author in his publication appear to be subject to errors resulting from the development of heat of shear, which has been calculated by the writer to lead to a rise of temperature of up to 70° C in the capillary for the higher readings)

Professor Bingham of Lafayette University may be considered to have undertaken a large part of the work in summarizing and contributing to the theory of plastic flow and the interpretation of data from the capillary plastometer, his earlier investigations culminating in the publication of his book *Fluidity and Plasticity* in 1922

A number of subsequent publications on the application of the plastometer to investigations on plastic bodies, however, appear to show that the simple interpretation of the data as set out by Bingham and his co-workers was not adequate Whilst the latter claimed that the capillary stress-shear plot of a plastic body could be represented by a hyperbola with its vertex at the origin, the asymptote on extrapolation being representative of the rigidity or yield value, and the slope of the asymptote as the mobility, failure to obtain linear asymptotes and the non-agreement of the data when reduced to absolute units led other investigators to employ empirical formulae to characterize the flow The principal among these were the logarithmic types of formulae proposed by de Waele [38, 1923], Herschel [61, 1926], and Ostwald [71a, 1925], for which the original papers must be consulted The mere empiricism of the formulae, however, necessitates the adoption of certain assumptions concerning the conformation of the formulae to the actual results obtained, and moreover leaves them open to criticism on the score of non-conformity to dimensional units It is somewhat remarkable, however, that useful deductions as to the structure of heterogeneous systems have nevertheless been possible on such a basis, and from the point of view of convenience have much to recommend them [16, 1920, 35, 1930, 42, 1931, 50, 1923, 56, 1923, 61, 1926, 85, 1931, 87, 1926, 89, 1929]

The writer's empirical equation led to the formulation of the velocity gradient at the wall obtaining in capillary shear as

$$\frac{P}{Q} \frac{dQ}{dP} \left(+3 \right) \frac{Q}{\pi R^3} \quad [85, 1931, 86, 1929]$$

in place of $4Q/\pi R^3$ obtaining in the flow of fluids in Poiseuille's equation, wherein Q is the volume velocity of efflux in c c per second, P is the shearing pressure gradient, and R is the radius of the capillary.

Interpretation of Results

The data available with the plastometer as described comprise a series of relationships between pressures in cm

of Hg and efflux velocities in flowmeter units easily convertible into c c per second In the determination of the viscosity of fluids, the Poiseuille equation of capillary flow is based on an assumption of a complete dependence of velocity gradient on shearing stress and on a constancy of viscosity with either of these variables The experimental evidence having shown conclusively that Poiseuille's law is not obeyed for most heterogeneous systems, and particularly those having a high concentration of disperse phase, a number of formulae, many empirical, have been proposed to fit the facts At first sight the original formula proposed by Bingham [6, 1922] and mathematically developed by Buckingham would seem to be recommendable on the score of simplicity and close approximation In this formula the kinetic behaviour of plastic bodies in capillary shear is assumed to be defined by a mobility μ and a shear strength or 'yield value' f

$$\frac{1}{\mu} \frac{S-f}{Q}$$

where S = shear stress applied, Q = volume efflux velocity, and f = shear strength or yield value having the dimensions of a stress The equation is based on the attainment of an asymptotic value of the mobility μ at a sufficiently high rate of shear proportional to Q , but later experimenters were led to seek other formulae, as further experiments at progressively increasing rates of shear often showed the slope to increase correspondingly Foremost amongst the empirical formulae proposed were those of de Waele, Herschel, and later, Ostwald the so-called logarithmic formula

$$\mu \propto \frac{Q^\phi}{P} \quad (\text{de Waele and Ostwald}),$$

wherein ϕ is a non-dimensional constant characteristic of the material and less than unity excepting for true fluids

Whilst the above formula is only applicable to plastic materials above certain rates of shear or to non-Newtonian fluids devoid of rigidity, the equations of Herschel and that of de Waele appearing in his later publications were

$$\mu \propto \frac{Q}{(S-K)^N} \quad (\text{Herschel})$$

$$\text{and} \quad \mu \propto \frac{Q^N}{S-K} \quad (\text{de Waele})$$

The exponent N in the Herschel equation was over unity for other than true fluids, and the rigidity term K was assumed to be constant with the rate of shear In de Waele's equation, however, K was claimed to vary with the rate of shear from zero at complete deflocculation (high rate of shear) to a maximum at a lower rate of shear when the shear in the capillary was inadequate to secure any deflocculation and the material extruded as a solid plug The value of K at zero stress was then calculated from the experimental data

Without entering into a discussion as to certain objections applying to these formulae, it may be noted that Rabinowitch [76, 1929] derived a general equation of flow which did not involve assumptions either as to experimental results or as to the invariability of viscosity with rate of shear A publication by Mooney [71, 1931] gives the mathematical treatment for the derivation of the Poiseuille equation which essentially differs from that of Poiseuille in the velocity gradient term

$$\frac{4Q}{\pi R^3} \quad (\text{Poiseuille}) \quad (1)$$

$$3 \left(Q + \frac{P}{3} \frac{dQ}{dP} \right) / \pi R^3 \quad (\text{Weissenberg}) \quad (2)$$

This latter expression, it may be noted, is identical with the velocity gradient term used by de Waele and applied to the shear of non-Newtonian fluids [85, 1931]

$$\left(\frac{1}{\psi} + 3\right) Q / \pi R^3,$$

$$\text{where } 1/\psi = d \log Q / d \log P = \frac{dQ/P}{dP/Q}$$

The complete equations of flow as applied to capillary shear therefore are as follows

$$\text{Viscosity (of fluids)} = \frac{1}{\text{fluidity}} = \frac{\text{stress}}{\text{velocity gradient}} \quad (3)$$

$$\text{Mobility} = \frac{d(\text{velocity gradient})}{d(\text{stress})} = \frac{d\sigma'}{dS} \quad (4)$$

$$\text{Maximum stress at wall } S = \frac{PR}{2L} \quad (5)$$

where P = pressure in dynes/cm²,

R = radius of capillary,

L = length of capillary,

Q = c.c. per sec extruded

Hence

$$\text{Mobility} \quad \mu = \frac{8L}{\pi R^4} \left(\frac{dQ}{dP} + \frac{P}{4} \frac{d^2Q}{dP^2} \right) \quad (6)$$

$$\text{and Fluidity} \quad \psi = \frac{6L \left(Q + \frac{P}{3} \frac{dQ}{dP} \right)}{P \pi R^4} \quad (7)$$

It is to be noted that equations (1) and (2) become identical when applied to true fluids or when $dQ/dP = Q/P$ and that the reciprocals of equations (6) and (7) similarly conform to Poiseuille's equation

$$\eta = \frac{P \pi R^4}{8 Q L} \quad (8)$$

when $dQ/dP = Q/P$

It will be noted that the essential characteristic of the treatment just referred to lies in the fact that on account of the variation of velocity gradient and stress not necessarily being related by a simple coefficient as in Poiseuille's fluid flow, stress-rate of efflux relationships are not always identical with stress/velocity gradients results. In other words, earlier interpretations depending on the use of the expression

$$\frac{\text{volume rate of efflux}}{\text{stress}}$$

for the evaluation of $1/\eta$, μ , or ψ , are not to be taken at their alleged value when applied to materials other than true fluids

Fortunately, the interpretation of results from plasto-meter data is far simpler than the foregoing equations would suggest when a graphical method is adopted for calculation of the velocity gradients from the experimentally determined volume-efflux velocities

Briefly, the method consists in plotting graphically the results of the plasmetric values in the convenient units, H (cm of Hg) and F (flowmeter units) as coordinates.

A derived plot of certain selected values of H against V' (arbitrary units proportional to velocity gradients) is then made, permitting the obtaining of a slope m proportional to mobility, and intercept H' proportional to stress intercept. The application of instrument factors to these two values then gives in a simple manner the dimensional mobility and rigidity sought

Whilst a detailed explanation of the mathematical treatment is omitted, the steps necessary will be grasped readily by following the graphical operations

A plot is first made of the plasmetric data connecting H (cm Hg) and F (flowmeter units) (Fig 7, line AB).

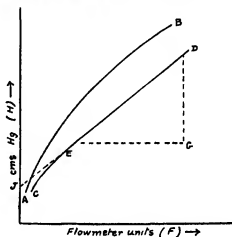

FIG 7

At points corresponding to values of H conveniently divisible by 3, tangents to the line are laid out by means of a celluloid ruler. Values of F corresponding to $H + \frac{1}{3}H$ are then sought along the tangent line and are plotted against values of H . By this means a secondary or derived curve CD is obtained. It will be observed that this line CD is somewhat less curved than AB and an upper portion ED may be found to be linear. The values of F on the line ED being related to the true velocity gradient by a simple multiplying factor and the corresponding values of H being similarly connected to stresses, the slope EG/DG gives a value m proportional to the true mobility. Similarly, the intercept J is proportional to the virtual rigidity

From the algebraic treatment above it will be obvious that the magnitudes of the flowmeter units on the CD line shown above have the values corresponding to

$$V' = F + \frac{H}{3} \frac{dF}{dH}$$

and therefore the value m of the slope derived above from the upper linear portion of the line

$$\begin{aligned} \frac{dV'}{dH} = m &= \frac{d \left(F + \frac{H}{3} \frac{dF}{dH} \right)}{dH} \\ &= \frac{4}{3} \frac{dF}{dH} + \frac{H}{3} \left(\frac{d^2F}{dH^2} \right) \end{aligned}$$

Multiplying m by the apparatus factor $6Lk/\pi R^4 g_p$,

where L = length of capillary,

k = factor for converting flowmeter units

F into c.c. per sec,

R = radius of capillary,

$g = 981$,

$\rho = 13.6$,

the mobility μ ,

$$\mu = m \frac{6Lk}{\pi R^4 g_p} = \frac{8Lk}{\pi R^4 g_p} \left(\frac{dF}{dH} + \frac{H}{4} \frac{d^2F}{dH^2} \right) \quad (9)$$

identical with that in equation (6) is obtained.

The graphical rigidity f obtained as an extrapolated

value of the pressure in cm Hg (H' or the point J in Fig 7) is then converted to absolute units (dynes per cm²)

$$f = \frac{H'gpR}{2L} \quad (10)$$

A detailed consideration of data from the plastometric examination of a typical plastic body will be useful in illustrating practical interpretation

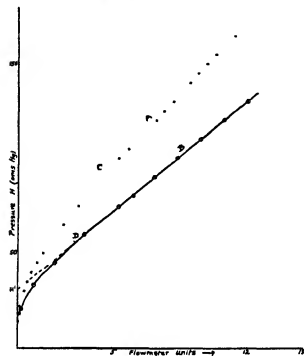

FIG 8

In Fig 8 the plastometric results accruing from the shear of a 5% by volume paste of American carbon black in castor oil are shown. Curve A shows plottings of pressures (cm Hg) as ordinates, and flowmeter units as abscissae. Curve B shows the derived plot of the same pressures against values of V' . It will be seen that whilst line A shows linearity only from the highest point recorded down to the point C , the derived pressure/velocity gradient line B is linear down to the point D . From this upper linear portion of curve B the slope m and the intercept H' can be determined, the corresponding dimensional mobility μ and rigidity f being then directly obtained by use of the apparatus factors (equations 9 and 10 respectively).

Several interesting points arise out of consideration of Fig. 8 which have a general application to all results of capillary shear of plastic or non-Newtonian bodies. Values at such low rates of shear as were not directly measurable with the flowmeter device comprising the open air-leak were obtained by plugging the latter and converting the observed rate of flowmeter units at each given pressure to open air-leak flowmeter units. The direct H/F results and

the derived H/V' line are shown in Fig 9. From this latter figure it is evident that whilst a continuous curvature appears to persist down to pressures of about 18 cm Hg, a change of curvature then sets in down to the lowest recorded figure of 6 cm Hg. Although no evidence is available in the diagram to show the actual path of H/V' line below such pressure, it is quite obvious from the nature of the material examined (which was definitely semi-solid and hence did not flow at very low stresses) that the H/F line must cut the stress axis at some value characteristic of its yield point. Thus the curvature of both lines must change in direction at still lower values in order to extrapolate to the H axis.

This change of flow régime at low rates of shear or the unexpected slow flow of semi-rigid materials in all forms of apparatus is to be considered as an instrumental phenomenon having for its basis a slippage consequent on a thin layer of free continuous phase separated by syneresis and virtually acting as a lubricant at the walls of the capillary (at the particular radius of flow where the stress is greatest). However, the phenomenon must not be regarded as an intrinsic characteristic of plastic flow, but merely as a secondary manifestation due to instrumental inability to submit plastic material for an infinitesimally short time only to shear under conditions in which the capillary effect of a foreign body (capillary wall) is absent. This disturbing factor and its resulting effect are referred to at this juncture in order to call attention to the unjustifiable interpretation of data from very low shear capillary instruments (Bingham-Murray plastometer, &c).

In Fig 10 are shown the results obtained by plotting the first derivative of the data from Fig. 8, viz

$$\frac{dV'}{dH} / H \text{ or } m/H$$

and showing the variation of mobility with stress.

The figure, which has been derived from the principal points, shows the fundamental characteristics of suspensoid plastics

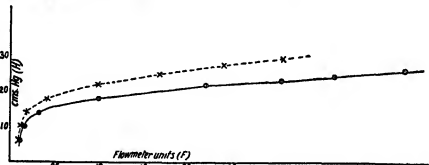

FIG 9 Experimental and derived data from shear of a plastic material at very low rates of shear

- (1) Zero mobility up to a certain critical stress
 - (2) Increasing mobility with increasing stress up to a certain critical value of stress
 - (3) Constant mobility beyond the upper critical stress
- Fig. 11 is a distribution curve connecting du/dH with stress. It is merely of interest as showing that the intercept H' in Fig 8 (carbon black in castor oil) closely marks a mean value of the stresses over which mobility is changing with increasing stress, and indicates how it may thus be taken as a characteristic of the material.

Similar types of these representative curves are shown by

all suspensoid plastics, i.e. systems comprising a non-deformable disperse phase

An important class of systems typified by emulsoids wherein the disperse phase can be assumed to possess

solids, highly dispersed oil-water emulsions, concentrated liquid soap sols, &c. At all but very high concentrations non-Newtonian fluids do not exhibit tangle rigidity, but appear to flow freely

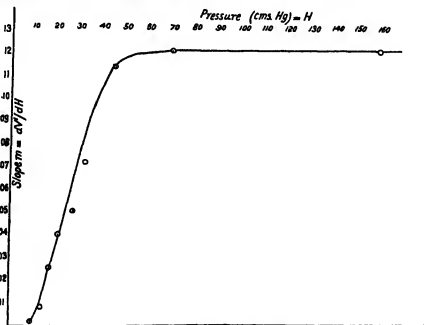

FIG 10 Variation of μ with stress of a plastic material

elastic deformability, and which will simply be referred to as non-Newtonian fluids, merit special consideration

Apart from the manifestation of high consistencies at relatively low concentrations, these outwardly resemble true (Newtonian) fluids, and have indeed often been assumed

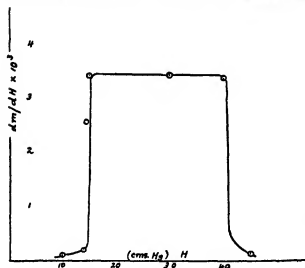

FIG 11 Change of $\frac{d\mu}{dH}$ with stress in plastic material or $\frac{d(\text{mobility})}{d(\text{stress})}$ at different stresses

to be such. Their claim to consideration as plastic bodies in the general sense, however, is justified by their variability of apparent viscosity with rate of shear. Typical examples of such systems are furnished by cellulose ester sols, rubber

In Fig 12 are shown the primary H/F and derived H/V' curves for a 5% sol of cellulose nitrate in butyl tartrate. It will be seen that the H/V' line, whilst linear at upper values of stress, exhibits a continuous curvature downwards and has its apparent origin at the common origin of the coordinates. This latter behaviour, it will be noted, is in accordance with the complete absence of rigidity and is a characteristic of true fluids. On the other hand, the linearity at upper values of the coordinates would, by the criterion adopted in the case of suspensoid plastics, indicate a positive rigidity. In Fig 13 is shown a plot of dV'/dH line against H or m/H , such curve determining the rate of change of μ with stress.

The curve shows similarity with the corresponding curve of a plastic suspensoid in that a constant mobility is shown above a certain critical value of H , but differs in the important respect that it extrapolates to a positive value of μ at zero stress. It is to be noted that such systems sometimes may exhibit a second range of constant mobility at the very low values of stress obtained with falling sphere viscometer.

Figs 14 and 15 give an example of the applications of the plastometer to practical work in showing the effect of the progressive addition of water to an ordinary calcium oleate—mineral oil grease. It is interesting to note that

- (1) The initial addition (2%) actually results in a loss of consistency (increase in mobility and loss of rigidity)
- (2) Rigidity ceases to increase with increasing addition of water at a point where difficulty is experienced in retaining it as a stable disperseate

The usefulness of the plastometer in other problems will readily occur to the technologist, e.g. shortening the time/stability testing of suspensions and emulsions, com-

paring the polarity of lubricating media, &c, but a more complete discussion as to the relationship between the plastometric constants and such obviously connected factors as interfacial tension, wetting power, &c, would be outside

delay of gelation of the former by disturbance constitutes the main difficulty in a reproducible determination of the setting time of gelatin sols, whilst the thixotropic properties of petroleum jelly make the question of its plastometric

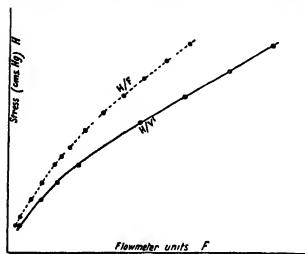

FIG 12 Experimental and derived curves of the shear of non-Newtonian fluid (cellulose nitrate sol)

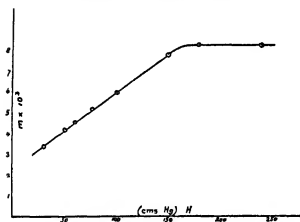

FIG 13 Variation of mobility with stress on shear of non-Newtonian fluid (cellulose nitrate sol)

the scope of this article. It is felt, however, that this short introduction to the subject will serve to arouse interest in a means of investigation and evaluation that has hitherto not been sufficiently cultivated.

No detailed reference has been made to the useful results which have often been obtained by interpretation of stress/shear data on the basis of empirical and semi-empirical formulae, as it is felt that the simplicity of a treatment involving no assumptions will form its own recommendation.

Thixotropy

Our present knowledge of thixotropy appears to be mainly qualitative in nature, as the published work on this phenomenon is confined to the measurement of the change of consistency (or its reciprocal fluidity) with rate and duration of shear. Thus, thixotropy, simply expressed, merely implies a reversible deflocculation. Perhaps the most familiar instances of thixotropic materials are gelling gelatin sol and also petroleum jelly. The regression or

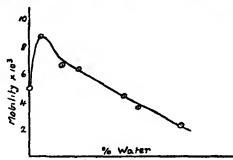

FIG 14 Change in mobility engendered by increasing addition of water to lime-soap grease.

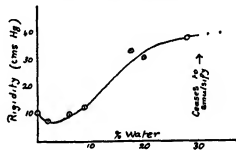

FIG 15 Change in rigidity engendered by increasing addition of water to lime-soap grease

evaluation a matter of difficulty. In Fig 16 are shown the results obtained from the plastometric examination of a thixotropic material in a Stormer viscometer, the ordinates being load in grammes and the abscissae the corresponding

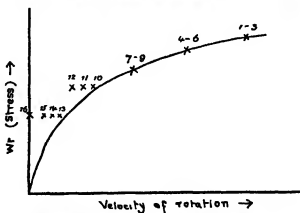

FIG 16 Shear of petroleum jelly in rotary (Stormer) viscometer

velocities of rotation. The numbers appended against the experimentally obtained points represent the series numbers of the tests. Thus, whilst 1-3, 4-6, and 7-9 showed reproducible readings, tests 10-16 showed increases in apparent consistency as the tests proceeded until test number 16 corresponded to the application of a load (shearing stress) which failed to induce any shear of the material, whilst the earlier tests 13-15 at the same stress resulted in positive but varying speed of rotation.

The results indicate that the stresses corresponding to tests 1-9 resulted in rates of shear so far in excess of the time effect of reflocculation that virtual equilibrium of these two processes was attained, whilst with the other

of time since previous shear of the material, and the abscissae give the difference between the 'kick' or ballistic deflection of the needle indicator and that in the steady state for a given rate of shear. It is evident that the differences are

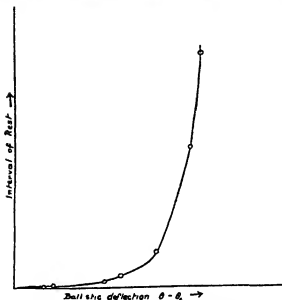

FIG 17 Thixotropic effects shown by soft printing ink in McMichael (rotary) viscometer

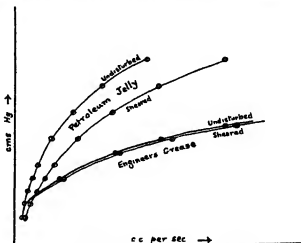

FIG 18 Thixotropic and non-thixotropic plastics

proportional to the thixotropic increases of consistency with flocculation. On the other hand, investigation of thixotropy with a capillary plastometer indicates the change on shear to be purely an increase in the mobility

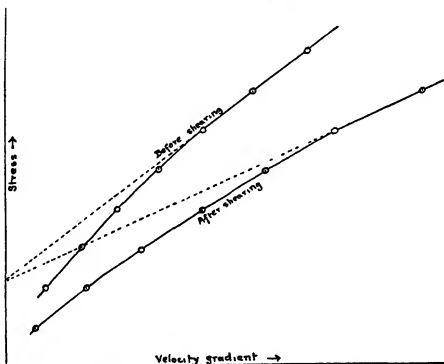

FIG 19 Thixotropy of carbon black in blown rape oil

tests the rate of reflocculation was greater than the rate of deflocculation due to shear.

In Fig 17 are shown the results from a series of experiments from the examination of a soft printing ink in a McMichael viscometer. The ordinates represent intervals

of the material. Fig. 18 shows a comparison between the stress/volume velocities of undisturbed and recently sheared vaseline and calcium grease respectively as obtained with a capillary plastometer, indicating the thixotropy of the former and virtual non-thixotropy of the latter. Fig. 19

shows the H/V' data for an unsheared and a recently sheared paste of carbon black in blown rape oil, and shows clearly the similarity of the rigidities but increase in mobility due to shear.

The importance of considering possible thixotropic effects

lines clearly show the increase of mobility with time of shear (L/R) but equality of intercepts (rigidities) Fig. 21 shows the plot of a similar series of tests with three capillaries of differing radii and lengths, but equal ratios of length to radius. In these tests, the times of shear during

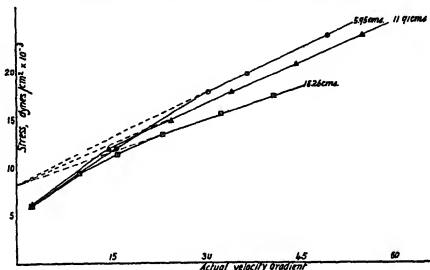

FIG 20 Special thixotropic behaviour of petroleum jelly in capillary of shear

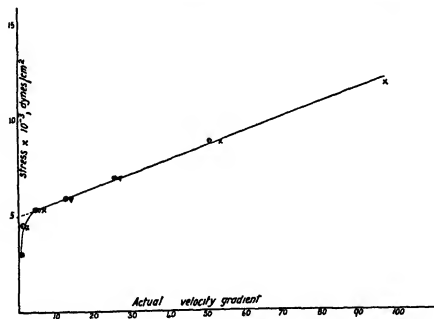

FIG 21 Absence of thixotropic manifestation of petroleum jelly when using capillaries of similar R/L ratios

in plastometric measurement is shown in Fig. 20. The results show the plotting of stresses against velocity gradients (in absolute units) accruing from the shear of a sample of petroleum jelly with three capillaries of equal radii but varying lengths. Under these conditions the material would, during the tests, be maintained under shear for times proportional to the lengths of the capillaries, hence deflocculation should be similarly in this order. The

which the material was subjected to shear were therefore similar, and the identity of the slopes and intercepts in the three cases furnishes a conclusion in accordance with the reasoning.

It is thus evident that with strongly thixotropic materials, the conditions of shear, i.e. ratio of R/L of capillary, need specifying when plastometric 'constants' are sought.

REFERENCES

- APPARATUS AND GENERAL
- 1 BAILEY, C. H. *J Rheology*, **1**, 429-32 (1930) Measurement of relative plasticity
 - 2 BECK, W. *Farben-Zig* **34**, 2515-18 (1929) Torsion viscometer for paints
 - 3 BISHRI, J. *Kautschuk*, **8**, 2-5 (1932) Plasticity measurements in the rubber industry
 - 4 BINGHAM, E. C. *B S Scientific Paper*, no. 278 (1916) Laws of plastic flow
 - 5 BINGHAM, E. C., and GREEN, H. *A S T M* **19**, 1-25 (1919) Paint, a plastic material, the measurement of its mobility and yield value
 - 6 BINGHAM, E. C., McGraw-Hill Book Co. (1922) *Fluidity and Plasticity*
 - 7 BINGHAM, E. C., and MURRAY, H. *Proc A S T M* **23**, 655-68 (1923) Combined viscometer and plastometer
 - 8 BINGHAM, E. C., and ROBERTSON, J. W. *Kolloid-Z* **47**, 1-5 (1929) Simultaneous measurement of plasticity and elasticity
 - 9 BINGHAM, E. C., and STEPHENS, R. A. *Physics*, **5**, 217-20 (1934) Consistency of very stiff materials
 - 10 BUCKINGHAM, E. *Proc A S T M* **21**, 1154 (1921) Plastic flow through capillary tubes
 - 11 BULKLEY, R., and BITNER, F. G. *J Rheology*, **1**, 269-82 (1930) A new consistometer
 - 12 *Eng. Stand. Tech. News Bull.* **142**, 17 (1929) Consistency measurement for calcined gypsum
 - 13 DAVIS, D. S. *Paper Trade J.* **88**, 42-3 (1929) Consistency tester (for paper stock)
 - 14 GIBSON, W. H., and JACOBS, L. M. *J C S* **117**, 473 (1920) Falling sphere viscometer
 - 15 GRAEFE, E. *Petr Z* **24**, 1599-1603 (1928) Penetrometers for asphalt
 - 16 GREEN, H. *A S T M* **20**, 1-32 (1920) Paint, a plastic material, the measurement of its mobility and yield value
 - 17 GREGORY, RASWILEY, and LAMPERT *J Rheology*, **1**, 30-45 (1929) Modified plastometer for industrial use
 - 18 HERSCHEL, W. H. *Ind Eng Chem* **12**, 282 (1920) McMichael viscometer
 - 19 *J Optical Soc America*, **7**, 335 (1923) Improved McMichael viscometer
 - 20 *Ind Eng Chem* **19**, 134-9 (1927) Burette consistometer
 - 21 *J Rheology*, **1**, 68-75 (1929) Multiple bulb consistometer
 - 22 HIND, S. R. *Trans Ceram Soc* **29**, 177-207 (1930) Measurement of the plasticity of clay
 - 23 HORLETRA, J. *Physics*, **4**, 285-8 (1933) The balance-plastometer
 - 24 HOUWINK, R. *Akademische Verlagsgesellschaft*, Leipzig, **2** Physical properties and structure of resins
 - 25 KAMPT, A. *Kolloid-Z* **51**, 165-7 (1930) A new viscometer
 - 26 KARRER, E., DAVIES, J. M., and DIETRICH, E. O. *Ind Eng Chem, Anal Ed* **2**, 96-9 (1930) Simplified Goodrich plastometer
 - 27 LOEBERMAN, M. M. *Ind Eng Chem, Anal Ed* **2**, 25 (1930) Rapid determination of relative viscosities of opaque fluids
 - 28 McMILLEN, E. L. *J Rheology*, **3**, 75-94 (1932) Measurement of thixotropy (Kampf viscometer)
 - 29 MOONEY, M., and EWART, R. H. *Physics*, **5**, 350-4 (1934) The conical viscometer
 - 30 PECK, JR., R. L. *J Rheology*, **3**, 345-72 (1932) Parallel plate plastometry
 - 31 PICKARD, H. *Chem and Ind* **50**, 1000 (1931) Viscosity of tar, pitch
 - 32 RIGO, G., and CARPENTER, L. *Ind Eng Chem* **4**, 901 (1912) The Stortmer viscometer
 - 33 SCHENCK, O. *Kolloid-Z* **51**, 167-71 (1930) Calibration and testing of Kampf's viscometer
 - 34 SCOTT, J. R. *Trans Inst Rubber Industry*, **7**, 169-86 (1931) The parallel plate plastometer
 - 35 SCOTT-BLAIR, G. W. *J Rheology*, **1**, 127-38 (1930) Rheology of soil pastes
 - 36 SCOTT-BLAIR, G. W., and SCHOFIELD, R. K. *J Rheology*, **3**, 318-25 (1932) The psychometer for testing materials (clay, flour)
 - 37 SWARD, G. C., and STEWART, J. R. *Amer Paint and Varnish Mfrs Assoc Circular* **394**, 317-22 (1931) The mobilometer
 - 38 DE WALLE, A. *J Oil and Colour Chem Assoc* **6**, 33-69 (1923) Viscosity and plastometry
 - 39 *Kolloid-Z* **36**, 332 (1925) Variation of viscosity with rate of shear of dispersive systems
 - 40 WILLIAMS, I. *Ind Eng Chem* **16**, 362-4 (1924) Plasticity of 32-50 (1925)
 - 41 WOLZ, A. *J Sci Instruments*, **9**, 22-4 (1932) Asphalt penetrometer
 - 42 WOLFF, H. *Kolloid-Z* **55**, 81-5 (1931) Viscosity and elastic flow of paint materials ("Turboviscometer")
- APPLICATIONS
- 43 AMERRE, H. A., and LOOMIS, A. G. *Physics*, **4**, 265-73 (1933) Thixotropic gels
 - 44 ARVENSON, M. H. *Ind Eng Chem* **24**, 71-5 (1932) Flow of petroleum lubricating greases
 - 45 BARTLETT, F. E., and HERBERGER, A. *J Rheology*, **2**, 177-208 (1931) Plasticity and degree of wetting
 - 46 BINGHAM, E. C. *J Rheology*, **2**, 10-107 (1931) Rheology name index
 - 47 *J Rheology*, **2**, 424-45 (1931) Rheology subject index
 - 48 *J Franklin Inst*, January (1932) Plasticity and elasticity
 - 49 BINGHAM, E. C., BRUCE, H. D., and WOLKACH, JR., M. O. *Ind Eng Chem* **13**, 1014 (1922) The Plastometer
 - 50 BINGHAM, E. C., and JACQUES, A. G. *Ind Eng Chem* **15**, 1033-56 (1923) Plasticity of paint
 - 51 BINGHAM, E. C., and LOWE, B. *Colloid Symposium Annual*, **7**, 205-12 The nature of flow
 - 52 BINGHAM, E. C., and REINER, M. *Physica*, **4**, 88-96 (1933) Rheology of cement
 - 53 *B S Technologic Paper*, no. 234 (1923) Plasticities of clay
 - 54 KALLEN, J. H., and JOHNSON, N. *Physics*, **4**, 225-35 (1933) Plasticity of rubber
 - 55 DOGADKIN, B., and PEWNER, D. *Kolloid-Z* **53**, 239-45 (1930) Structure viscosity in rubber solutions
 - 56 FARROW, F. D., and LOWE, G. M. *J Textil Inst* **14**, T 414 (1923) Flow of starch paste through capillary tubes
 - 57 FRANCIS, A. W. *Physics*, **4**, 403-6 (1933) Corrections in falling sphere viscometry
 - 58 GREEN, H., and HASLAM, G. S. *Ind Eng Chem* **17**, 726 (1925) The Micropistolometer
 - 59 HASLAM, W. B. *Kolloid-Z* **51**, 6-9 (1930) Static viscosity and adsorption
 - 60 HATSCHKE, E., and JANE, R. S. *Kolloid-Z* **40**, 53-8 (1926) Viscosity of suspensions and its dependence on the shear gradient
 - 61 HAUSER, E. A. *J Rheology*, **2**, 4-9 (1931) Thixotropy
 - 62 HERSCHEL, W. H., and BULKLEY, R. *Kolloid-Z* **39**, 291 (1926) Consistency of rubber solutions
 - 63 HIRSCHL, W. H., and BROUQT, C. *Ind Eng Chem* **13**, 703 (1921) The consistency of starch pastes
 - 64 HERSCHEL, W. H., and DEAN, E. W. *Bureau of Mines* no. 2201, January (1921) McMichael viscometer for testing petroleum products
 - 65 IRVING, DR., and DIETRICH, W. F. *J Amer Ceram Soc* **12**, 14-29 (1929) Plasticity of clays
 - 66 KARRER, E. *J Rheology*, **1**, 290-7 (1930) Classification of plastic and definition of certain properties
 - 67 *Ind Eng Chem* **21**, 770 (1929) Meaning and measurement of plasticity
 - 68 KRAEMER, E. O., and WILLIAMSON, R. V. *J Rheology*, **1**, 76-90 (1929) Internal friction and "viscous" colloids
 - 69 LOOMIS, A., AMERRE, H. A., and KENNEDY, H. T. *Physics*, **5**, 207-16 (1934) Rheology of petroleum products
 - 70 McMILLEN, E. M. *J Rheology*, **3**, 163-78 (1932) Thixotropy
 - 71 MITCER, P. *J Rheology*, **3**, 391-414 (1932) Viscous friction and lubrication
 - 72 MOONEY, M. *J Rheology*, **2**, 210-22 (1931) Explicit formulae for slip and fluidity
 - 73 OSTWALD, W. *Kolloid-Z* **36**, 99 (1925) Velocity function in the viscosity of dispersive systems
 - 74 PETERS, H. A. *J Chem Weekblad*, **26**, 18-24 (1929) Plasticity of clay
 - 75 PITTMAN, C. V., and TRAXLER, R. N. *Physics*, **5**, 221-4 (1934) Rheology of asphalt
 - 76 POHRT, E. G., and MOSKOWITZ, N. *Ind Eng Chem* **14**, 49 (1922) The plasticity of corn starches
 - 77 PORTER, P. K., and GRUBB, W. A. *Ind Eng Chem* **17**, 953 (1925) Cup grease consistency
 - 78 RABINOWITZ, R. Z. *Phys Chem* **148**, 1-25 (1929) Viscosity and elasticity of sols
 - 79 REYNOLDS, M. *J Rheology*, **1**, 250-60 (1930) General law of the flow of matter
 - 80 SCOTT-BLAIR, G. W. *Physics*, **4**, 113-18 (1933) Yield value
 - 81 *J Rheology*, **1**, 127-39 (1930) Rheology of soil pastes
 - 82 SCOTT-BLAIR, G. W., and CROWTHER, E. M. *J Phys Chem* **33**, 32-50 (1929) Flow of clay pastes through narrow tubes
 - 83 SHARZER, W. L. *Ceramic Age*, **18**, 68-70 (1932) Consistency of slips and glazes.

- 82 SHEVETZOV, B. S. *Trans. State Expt. Inst. Silicates (Moscow)*, **21**, 15-20 (1927) Plasticity of clay
- 83 SIMPES, J. O. *Trans. Faraday Soc.* **27**, 161-76 (1931) Viscosity of emulsions
- 84 TERAGASHI, C. *J. Rheology*, **2**, 253-60 (1931) Static rigidity of plastic clays
- 85 DE WAELE, A. *J. Rheology*, **2**, 141-59 (1931) Thixotropy of pseudo-plastic systems
- 86 DE WAELE, A. *J. Rheology*, **1**, 139-47 (1929) Plastic and pseudo-plastic flow
- 87 ——— *J. A. C. S.* **48**, 2760-75 (1926) Interfacial forces in dispersed systems
- 88 ——— *Kolloid-Z.* **38**, 27-32 (1926) Notes on plasticity
- 89 DE WAELE, A., and LEWIS, G. L. *Kolloid-Z.* **48**, 126-41 (1929) Plastometry and the structure of interfaces

THE FLOW-TEMPERATURE METHOD OF DETERMINING THE ACTION OF COLD ON OILS, GREASES, AND LUBRICANTS, DERIVED FROM PETROLEUM

By Dr. P. WOOG
University of Strasbourg

General Theoretical Considerations

The effects which low temperatures have on oils, lubricants, fuels, &c., are important and should be known in order to evaluate the quality of the products and to choose for known reasons those products which are suitable for a particular application. Numerous methods have been formulated to this end, and from the standpoint of technique that which appears to be of greatest value is the determination of the viscosity temperature curve. This method is, however, laborious for high-viscosity oils, and also it is known that the duration of the cooling affects the results. Moreover, the researches of Louis, Joldachescu, and Thiebault [3, 1935, 4, 1932], and of Erk [2, 1932] have shown that there is reason to consider the effect of plasticity which manifests itself at the limit of the viscosity range, thus rendering a viscosity curve traced by gradually lowering the temperature, not superposable with a curve obtained by gradually increasing the temperature. The limit thus imposed on the measurement of viscosity does not permit determinations to be made which give all the required information further, a large number of experiments are necessary in order to study the behaviour of oils at low temperatures, since in every case this zone is such that the measurement of viscosity is not accurate, that is, in the region of the freezing-point. For this purpose freezing-point methods are used, such as the 'pour-point' determination.

Again, however, serious difficulties are encountered, since oils, lubricants, &c., are not generally individual chemical substances possessing a constant solidification or fusion temperature, they are mixtures of various components in solution, the change of state of which is progressively effected. Further, the observed fusion or solidification point is generally rendered uncertain, due to the fact that the substances constituting the compound are between the liquid and the solid state, that is, they are in the intermediary condition, viz. viscous, very viscous, buttery, pasty, &c., which changes are not easily distinguished.

If it be said that crystallization takes place with the majority of the products formed in the paraffinic series, then this cannot be said for the naphthene or aromatic base products, for these latter, solidification is generally vitreous in nature, with no apparent crystallization.

In the experiments on the freezing-point the phenomenon of superfusion, or slow crystallization, is found to have a troublesome effect on its measurement. Attempts at decongelation or thawing would seem to be more precise and to give an exact value for the fusion-point. These methods have been studied for several years [6, 1929], and owing to the determination of the flow temperature described later, and which is in principle a convenient yet simple and precise point, several important phenomena have been evident which have caused considerable errors

these are a question of molecular changes effecting the freezing-point.

Using a mixture for example [7, 1931, 8, 1932] of 60% paraffin oil and 40% animal oil, e.g. mutton-fat oil, it was found to freeze at -75°C , using a freezing mixture of solid carbon dioxide in acetone. After remaining for 5 minutes in this bath some of it was then rapidly transferred to an acetone bath maintained at -30°C and some to another at -40°C . The temperature of each was then gradually allowed to rise, and the temperature at which the liquid flowed was noted.

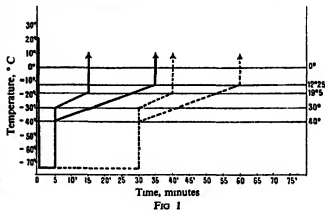

FIG 1

Under these conditions a noticeable variation was found in the flow temperature, i.e. in the bath at -30°C the flow temperature was found to be lower than the temperature obtained when the oil was placed in the bath at -40°C . These temperatures were -19.5°C and -12.5°C respectively, shown by Fig. 1.

By prolonging the freezing time at -75°C for 30 minutes the results obtained were the same (see Fig. 1). If, however, the time at -75°C was prolonged to 1 hour, then the differences obtained were not so regular.

After freezing at -75°C and then allowing the oil to warm up in this bath, the flow temperature was found to be -11.5°C . Successive determinations gave the same result. It will be seen, therefore, that the flow temperature was much higher than when the experiment was carried out starting at -40°C .

Initial temp of reheating bath $^{\circ}\text{C}$	Duration of reheating	Flow temperature $^{\circ}\text{C}$
-30	10 min.	-19.5
-40	30 min	-12.5
-75	83 min	-11.5

Thus the flow temperatures are higher if the reheating is commenced in a bath at a lower temperature further, since the behaviour on reheating of these baths which

contain the same volume of liquid are sensibly the same, it would appear therefore that the duration of reheating has some influence.

If a sample be frozen by lowering the temperature extremely slowly, there is a tendency to suppress these anomalies, and in this case the highest flow temperature is obtained. There is evidence that a change in the crystalline structure of the oil causes these phenomena.

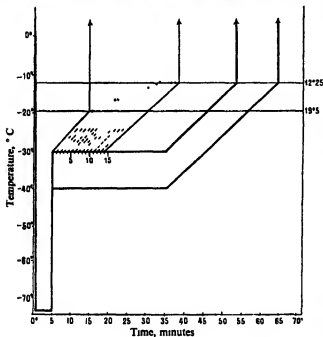

FIG 2

A summary of the thermal analyses does not show any appreciable irregularity in the reheating curve. Several experiments in which the oil frozen at -75°C was placed in a bath at -30°C and allowed to remain there for increasing periods of time, after which the oil was allowed to warm up in the usual way until the flow temperature was reached, have shown that this point has gradually risen. A curve of the flow temperatures of an oil which was maintained at -30°C for 12 minutes was found to correspond with a curve showing flow temperatures obtained after the oil was kept at a temperature of -40°C . Thus there is evidence of a transformation zone (Fig 2). Subsequent to these experiments the inverse procedure was adopted (see Fig 3). The oil frozen at -75°C was allowed to attain -30°C and then maintained at this temperature for 15 minutes until the transformation was effected. The sample was then replaced in the -75°C bath for 5 minutes, and then again placed in the -30°C bath. It was then allowed to warm up and the flow temperature was found to be -12.25°C . The experiment was then stopped and the temperature of the oil allowed to attain -11°C , at which it was maintained for 10 minutes.

An oil thus subjected to a temperature of -75°C for 5 minutes and then transferred to a bath at -30°C was found on reheating to have a flow temperature of -14°C . The oil was then allowed to reach a temperature of -10°C , and after being kept thus for 10 minutes it was then replaced in the -75°C bath for a further 5 minutes. On placing it once more in the -30°C bath, the flow temperature was found to have been lowered to -15°C . Again the oil was warmed to -8°C for 10 minutes,

replaced in the bath at -75°C for 5 minutes, and then placed in the -30°C bath and allowed to warm up. It was found by repeating this procedure that the initial flow temperature of -19.5°C was again reached.

These phenomena, which have been described in regard to a particular oil mixture, have been found to apply to other oil mixtures. The variations between the flow temperatures are found to be general. They are of varying importance, some differences being small, whilst others may be as much as 12 degrees. These variations do not occur when the pure mineral oils are used and not the mixtures. The following table gives the flow temperatures for three types of oil.

Oil	Temperature of reheating bath		
	-75°C	-40°C	-30°C
	Flow temperatures		
Naphthenic 4,866	-17.4°C	-21.3°C	-31.3°C
Asphaltic 3,617	-21.0°C	-24.2°C	-23.3°C
Paraffinic 1,203	-8.6°C	-12.8°C	-14.2°C

The following figures give the characteristics of the oils

Oil	4,866	3,617	1,203
Density $15^{1/4}\text{C}$	0.9095	0.9456	0.9042
Coefficient of kinematic viscosity at 35°C	1.296	3.40	0.69
" 50°C	0.505	1.13	0.33
" 100°C	0.0835	0.12	0.078

With these latter oils the phenomenon was directly observed, a tube containing several cubic centimetres of the oil was used and a thermometer placed in the centre. It was observed that on rapidly cooling to -75°C the highly refined oils on solidification were transparent or colourless, and that the surface of the oil was cone-shaped

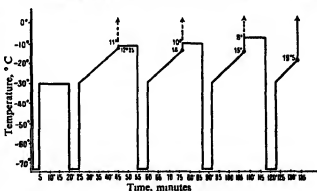

FIG 3

(Fig 4) On allowing the temperature to slowly increase the oil was found to become slightly turbid. This opalescence was more noticeable when the apparatus was suspended by the thermometer, so that the frozen oil was submitted to a tension equivalent to the weight of the apparatus. These phenomena were not observed with the mixtures of mineral oils and triglycerides, such mixtures on sudden freezing gave transparent vitreous masses which rapidly changed to a white porcelain colour.

It has been proved that the water content of the oil does not have any effect. The results obtained were exactly similar whether the oils were dehydrated under vacuum in the presence of phosphorus anhydride, or whether they were left in an atmosphere saturated with water vapour.

The different flow temperatures observed correspond

to the varying state of the oil, such states being known to exist as shown by the triglycerides, and are attributed to superfusion. In these other cases, however, the phenomenon is otherwise it consists of a false equilibrium or tempering of the oil, similar to the tempering of metals, followed by annealing. The rapid solidification of the oil does not allow sufficient time for the crystals to form the vitreous state thus obtained is unstable and does not show any change at very low temperatures, since by raising the temperature the formation of stable crystals increases.

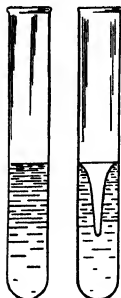

FIG 4

In proportion to the time which elapses between the commencement of crystallization and the point when the oil flows, different flow temperatures are obtained. The vitreous form, which has the lowest fusion temperature, gave higher flow temperatures as the crystallization of the oil increased. The flow temperatures were at a minimum in a bath at -30°C and at a maximum when the reheating took place from -75°C , the duration of the operation permitting. In this case the devitrification was more advanced. It should be understood that the crystallization does not produce a rigorously fixed point, the flow temperature being subject to some irregularities which can be kept at a minimum by

carrying out the operations in an exactly similar manner and by allowing the frozen oil to warm up from a bath at -75°C .

The action of cold on the liquids studied was always effected in the same manner, the essential conditions being the same in order to obtain legitimate comparisons. The products must be always in the same physical state, therefore it is necessary not to make even the slightest modification which could alter the physical state of the sample.

It would be possible to submit samples to some thermal treatment capable of restoring the original state of the true liquid, depriving it in particular of all crystalline form, or earlier thermal history. These experiments have shown that heating the sample to 100°C for 15 minutes was necessary and sufficient. This process is analogous to that obtaining in metallurgy and is capable of completely vitiating the results if not taken into consideration.

If a fuel oil, for example [9, 1934], be submitted to thermal treatment for 15 minutes at 100°C and then immediately frozen, i. e. the hot liquid is immediately placed in the apparatus at -75°C , then the flow temperature obtained has been found to agree very closely with the normal flow temperature. If, however, the experiment is repeated and the preheated oil placed first in the apparatus at plus 20°C and allowed to remain there for 1 hour before cooling to -75°C , then the flow temperature is identical with the figures already given. Again, by repeating this experiment but allowing the oil to cool to 0°C and then maintaining it there for 1 hour before cooling it to -75°C , a sharp lowering of the flow temperature is obtained. These results are the same whether the oil is maintained at 0°C for times varying from 1 hour to 8 hours.

This phenomenon is generally observed. It can be pro-

duced regularly and easily. The variation between the normal flow temperature and that obtained after remaining at 0°C can be small or large, a difference of 25.8°C having been recorded.

It is thought that the cause of these variations, which are only found to occur with paraffinic products, is due to their paraffinic nature. The preheating leads to a complete dissolution of the paraffins in the liquid, and when the sample is rapidly frozen the solution solidifies before any change takes place. Thus a solid solution is obtained which has a normal flow temperature. On allowing the oil to stand at 0°C the solubility coefficient of the paraffins is diminished and they more or less separate from the mixture. There is, therefore, the apparent segregation of a solid paraffin phase dispersed in the liquid, and when the sample is re-cooled preceding the flow temperature, then the inter-crystalline liquid solidifies and the flow temperature corresponds to that of the inter-crystalline liquid. The oil deprived of part of the paraffins which it initially dissolved can only give a flow temperature lower than that originally observed. The separated paraffins are very stable. They can exist in the crystalline solution, even if the sample be reheated to 35°C or for 30 minutes at 50°C . It has been found necessary to maintain the sample at 50°C for 1 hour or for 15 minutes at 100°C in order to 'sterilize' the liquid. For further information reference should be made to the work of M. Bourdill [1, 1933] on castor oil and the solid glycerides which form in this oil.

The temperature at which separation of the paraffins takes place is not constant, it varies with the composition of the liquids. If the oil is allowed to remain at 16°C instead of 0°C , then this would be sufficient to cause a lowering of the flow temperature. There would appear to be no means of establishing a simple relationship between the amount of separation as shown by the difference in the flow temperatures of the oils and their composition. The problem is, in fact, a complex one, asphaltic bodies in particular cause a large amount of trouble. It should be noted that the term 'paraffins' designates numerous bodies whose fusibilities differ, and that the hard paraffins behave very differently to the vaselines. The following table gives several examples.

Product	% paraffin content	Flow temperature		Difference A~B
		Normal A	Oil kept at 0°C B	
Oil 8,101	0	-28.9	-28.7	0.2
Oil 8,101 3% pure vaseline	0	-7.1	-18.1	11.0
Oil 8,101 3% paraffin m p				
60/62°C	3.0	+7.3	+1.4	5.9
Fuel 10,621	1.35	-23.5	-23.0	1.5
" 10,623	1.56	+0.2	-4.2	4.4
" 10,607	1.75	-21.0	-28.9	7.9
" 10,801	0.77	-12.8	-24.7	11.9
" 10,622	3.92	+9.5	-5.6	15.1
" 10,307	4.05	+7.0	-12.0	19.0
" 10,306	3.08	-0.25	-23.5	23.25
" 10,619	4.42	+3.8	-22.0	25.8

A Summary of the Effects produced by Cold. The Flow Temperature. A Precise Method for Determining the Flow Temperature

Fusion or melting is that phenomenon which consists of a body passing from the solid to the liquid state. In the following, reasons are given why this conception is not strictly valid, and it must be supposed in principle that the

melting-point of petroleum products free from pure physical characteristics are perhaps only defined and evaluated on the conventional basis. A knowledge of the phenomenon of tempering, annealing, and segregation of metals has led to the samples being tested under fixed conditions in order to obtain comparable results. Finally, it is important that the arrangement of the apparatus and sample should be such that the temperature read on the thermometer actually corresponds to the freezing-point of the sample. One condition necessary to effect this latter is that determinations should be carried out with small quantities of material in a thinned-walled apparatus. The method of solidification should be such that the apparatus is fully immersed in the freezing bath, the temperature of which and that of the oil should be identical.

The following is a definition of the flow temperature. It is that temperature at which a product, previously submitted to a prescribed thermal treatment and then frozen solid, begins to flow under standard conditions.

Method.

The sample used must always be submitted to a fixed thermal treatment previous to the test. A small receiver is then filled with the preheated liquid, into which a movable annular plunger is introduced, the apparatus is then placed in a freezing bath operated in such a way that the segregation phenomenon cannot be produced. It is necessary to freeze the sample rapidly, which causes a blockage of the plunger when this occurs, a constant tension is then exerted on the plunger and the temperature of the sample gradually allowed to increase. When the sample again becomes viscous the plunger is gradually liberated and is withdrawn from the receiver until finally the pouring temperature is reached. The freezing bath contains acetone saturated with carbon-dioxide snow, in which petroleum products are practically insoluble at these low temperatures.

Apparatus.

It consists (Fig 5) of an annular reservoir, *A*, 14 mm and 20 mm in diameter, with an internal diameter of 13.5 mm, in which the oil under test is placed. A disk, *B*, pierced with holes, on the end of a metal rod, *C*, holds the reservoir in place. This has an insulated end cap, *D*, and is enclosed in a glass tube, *E*, of 14.5 mm external diameter and 246 mm long, at its base is fixed a cylindrical brass piece 18 mm in diameter and 31.5 mm in height, which forms the plunger in *A*. Two openings, *G*, are made 13.5 mm from the base and 13.5 mm high by 5 mm wide. A diaphragm, *H*, acts as a guide for the vertical rod. At the top of the sleeve, *E*, a brass cap, *I*, 40 mm long, is placed and in the upper part of this a small hole is drilled, which acts as a further guide for the vertical rod. On the tip of the rod is a cap, *J*, from which a chain is attached to a spring plunger, *K*. A clamp, *L*, holds the rod rigidly in position while the apparatus is manipulated. A brass clamp holds the tube, *E*, firmly, thus leaving the reservoir, *A*, and the rod free to move. The movable rod and plunger is tared to 20 gm, and therefore it can easily fall if not prevented. The drop is limited by the tension of the chain. At the commencement of the experiment the reservoir, full of the frozen liquid, remains fixed to the brass piece, *F*, which was plunged into the oil before freezing. When the oil begins to flow, the movable part of the apparatus commences to slip and eventually falls to the limit of its travel.

The apparatus is placed in a double-walled vessel, con-

taining 130 cc of acetone, in which an alcohol thermometer is placed, together with a stirrer. The tip of the vertical rod, *D*, is made from non-conducting material in order to prevent the formation of frost which would impede the movement of the rod. This tip is graduated with an arbitrary scale, so that the movements of the rod can be approximately measured.

A small balancing arm, *N*, rests with its tip on the cap, *J*, this makes an electrical contact at the moment when the rod commences to move, and thus actuates a signalling device.

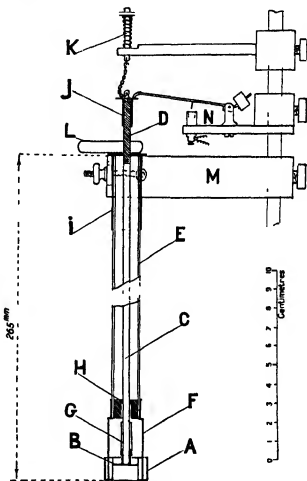

FIG 5

Experimental Procedure.

1 Preparation of the sample (oil, fuel, &c) The sample should be maintained in a water bath at 100° C for 15 minutes.

2 The hot liquid is placed in the annular reservoir, the vertical rod is then passed through the openings of the sleeve and its lower extremity immersed in the reservoir until its base just touches the bottom. The excess liquid is wiped from the sides of the reservoir and the chain attachment fixed in position. These operations should be carried out as quickly as possible so that the liquid does not have any appreciable time in which to freeze.

3 The liquid is frozen to -75° C by lowering the apparatus into the acetone bath containing a very slight excess of carbon-dioxide snow. The slow saturation with the snow should be maintained for 5 minutes. The flask containing

the acetone should always be filled to such a level that there is 130 c.c. present.

4. Without removing the reservoir from the freezing bath, the apparatus is fixed in the stand, the thermometer is placed in the bath to the same level as the annular reservoir and the chain is hooked to the spring plunger. The acetone is then stirred in such a manner that the sample in the reservoir is not disturbed.

5. At a given moment the annular reservoir, due to its weight, moves from the fixed sleeve, and its movements can be followed by the graduations on the rod. The temperature at which the reservoir completely separates from the brass sleeve is noted, this temperature being the flow temperature.

Observations.

1. If the flow temperature of the oil is lower than -40°C , then it must be allowed to remain in the acetone saturated with carbon-dioxide snow for 60 minutes instead of 5 minutes.

2. Agitation of the acetone bath is not absolutely essential, since the bubbles of gas evolved are sufficient to maintain it well mixed. The results obtained in this case are in very good agreement.

It will be seen that the determination of the flow temperature is a practical one, and quite automatic in operation, since after an experiment has been started the apparatus need not be watched until the electric alarm functions, thus showing that the flow temperature is near.

A recent modification has been made in this apparatus, in that the glass sleeve has been replaced by a metal tube in which numerous holes have been bored (see Fig 6). These holes diminish the thermal conductivity of the metal and permit an air current to circulate in such a manner that there is no frost formation. The apparatus thus modified is made entirely of metal, is robust and easily constructed.

Accuracy of the Results.

If the method of operation is carried out exactly, and the thermometers used are accurate, then concordant results can be obtained. Generally the figures obtained for successive experiments, on the same sample, do not vary more than a few tenths of a degree. It is seen, therefore, that the flow temperature is much more accurate than the 'pour-point', and that several pieces of apparatus can be used at the same time by the same operator. The flow temperature applies to all petroleum oils, such as crude petroleum, gas oils, fuels, and lubricating oils.

When products easily affected by the cold, and of which the flow temperature is greater than 0°C , are under test, then the warming of the acetone solution should be carried out much more slowly. In order to regulate the temperature in these cases the double-walled flask is placed on an electric heater, the current of which is regulated in such a way that the temperature of the bath increases about 1°C per minute.

The flow-temperature method can be applied to petrolatums and greases, but it is preferable to use the method of Pohl-Finker, with Ubbelohde's apparatus. The figures obtained in the two methods are analogous.

It should be noted that the figures obtained for the flow temperature are different to those obtained for the pour-point on the same product. The flow temperature is much lower than the pour-point, it should be possible to establish a relationship between the two temperatures, the differences obtained being more or less in accordance with

those given for paraffinic, naphthenic, and asphaltic products.

Finally, it should be pointed out that the manner in which the reservoir on the apparatus falls acts as an indicator, and that from the moment when the movable

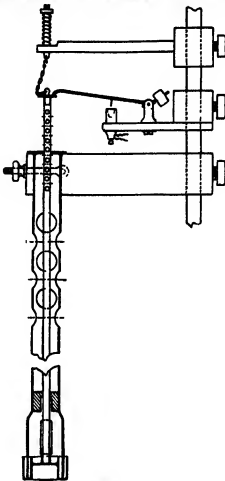

FIG 6

portion of the apparatus commences to slide, and the instant when it falls freely, i.e. the point at which the temperature is recorded, can be a short or a long time. In experiments in which paraffinic oils are used, the fall is always faster than when the naphthenic or asphaltic products are the liquids under test. Generally it can be said that with a rapid fall the product under test forms crystals. This theory is supported by the observations noted when various products were under test. Using the flow-temperature apparatus, varying the quantity of liquid used caused corresponding variations of the flow temperature. It will be seen from the curves, Fig 7, showing flow temperature plotted against quantity of oil used, that the paraffin-base oils have relatively flat curves and that complete fusion takes place within a range of a few tenths of a degree. On the other hand, the curves of asphaltic and naphthenic products are steep, since they only undergo a slow change of state, or rather their viscosity only diminishes progressively, and hence the time of fall of the brass plunger is prolonged.

The large number of determinations carried out in industry and in numerous laboratories have shown that there is a perfect regularity in the flow temperature, and that concordant readings can be obtained. It should,

however, be mentioned that irregularities do occur when exceptional types of mixtures of very different composition are used, for in these cases each particular component present exerts its own influence on the flow temperature. Thus the results obtained on various mixtures of castor

VARIATION OF THE FLOW TEMPERATURE WITH THE QUANTITY

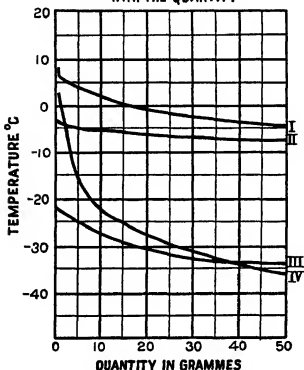

I } Paraffinic Oils
 II }
 III } Asphaltic Oils
 IV } Naphthenic Oils

FIG 7

oil were abnormal and variable, grouping themselves into two groups, namely, -30°C and -12°C , instead of attaining one fixed temperature. It is interesting to note that this exception is in agreement with the anomalous results obtained on similar oils, and shows the existence of vitreous and crystalline types.

The remarks made by Lord Rayleigh on the existence of a foreign substance in resin oil should be noted, as also should the work of W. Parsh and L. Cammen [5, 1932].

The fact that the flow-temperature method indicates the existence of the anomalies described shows the value of the method.

Determination of the Flow Temperature at Very Low Temperatures as in the case of Spirits

The principle of the flow-temperature method has been applied to spirits with the following modified apparatus (Fig. 8).

It consists of a thermo-couple, composed of a thick iron cylinder, *A*, in which is welded an iron rod, *B*, diametrically opposite to this a constantan rod, *C*, is brazed. Within the iron cylinder a solid block of aluminum is fixed, in the centre of which there is a small cavity, *D*,

7 mm in diameter and 50 mm in depth. The couple is connected to a galvanometer with iron wire from the iron rod, and with constantan wire from the constantan rod, this wire is broken and connected to an iron wire to form a cold junction, *E*. A cover of insulating material, *F*, separates the two rods *B* and *C*, and is fixed at a convenient height. In the centre of this cover a guide tube, *G*, is fixed, through which passes a 20-mm glass rod, *H*.

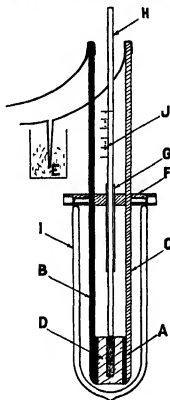

FIG 8

In order to carry out a determination, the rod, *H*, is removed and then the block is cooled to -185°C by plunging it into liquid air, contained in a Dewar flask, *I*, it is then removed and the liquid to be tested is placed in the cavity, the apparatus is again plunged into liquid air, removed, and more test liquid is added to the cavity to make up for the contraction due to cooling. This operation is carried out until the cavity is completely filled. The glass rod, *H*, is replaced in the guide, such that the tip just rests on the surface of the frozen liquid. The apparatus is then raised just above the surface of the liquid air so that it still remains inside the Dewar flask. The aluminum block is thus allowed to warm up slowly. A certain point is reached when the frozen liquid begins to soften, and can no longer bear the weight of the glass rod, which then begins to sink into the cavity. Its movement is noted by means of the scale, *J*, and the flow temperature is recorded by the galvanometer or pyrometer at the point when the glass rod, *H*, sinks to the bottom of the cavity.

The accuracy of the results obtained is satisfactory. Curves can be obtained which show the variation in the flow temperature of a spirit when increasing percentages of another spirit are added to it. The difference between the experimental and theoretical figures is of the order of 0.5 degree.

REFERENCES

- 1 BOURDOL. *Contribution to the Study of Viscosity and Freezing of Oils* (Paris, 1933)
- 2 ERK. *Z der Vereinig Deutscher Ingenieure*, 76, no 2, 33 (1932)
- 3 JOLDACHECU. Thesis Strasbourg (1935)
- 4 LOUIS, JOLDACHECU, and THEBAULT. Researches at L'École Nationale Supérieure du Pétrol. Published Dec 1932, Society of Rheology, Atlantic City
- 5 PARISH, W and CAMMEN, L. *J I P T* 8, 11 (1932)
- 6 WOOD, P. *Annales des Combustibles Liquides*, 3, 493 (1929)
- 7 WOOD, P., GANSTER, E., and COULON, F. *Compt rend* 193, 850 (1931)
- 8 ————. *Bull Soc Chim* 51, 127 (1932)
- 9 WOOD, P., GIVAUDON, J., and DAYAN, F. *Compt rend* 19 Feb 1934, p 744

VISCOSITY AND PSEUDO-PLASTICITY

By H. WEISS and M. LOUIS

A KNOWLEDGE of the viscosity of petroleum products is of use in connexion with their identification by physico-chemical tests, with the loss of head in forcing them through pipes and with the establishment of hydro-dynamical lubrication. Even in boundary lubrication there is often sufficient parallelism between oiliness and viscosity that the former may be inferred from the latter.

Measurements of viscosity are based on a more or less direct application of Newton's formula,

$$f = \eta S \frac{dv}{dx} \quad (1)$$

which gives the force f exerted on an element S of the area of a plane in the liquid when an infinite parallel plane at a distance x from this element moves with a uniform velocity v in its own plane. The constant η is the coefficient of viscosity for a normal liquid at nearly atmospheric pressure. η depends only on the temperature of the liquid, and not on the value of the gradient dv/dx .

The instruments recommended for the measurement of the coefficient η may consist of rotating concentric cylinders, of spheres falling freely in the liquid, or of tubes through which the liquid flows. All are equally good, according to the conditions of use, provided they are so designed that the liquid moves only in laminae or in parallel filaments. In fact the formulae on which the use of these instruments depends are all derived from the differential equation (1).

Except for some special cases, as in the viscometry of bitumens in the neighbourhood of their softening points, most of the practical instruments are based on flow in tubes.

Viscometers for Absolute Measurements.

In these instruments direct measurement of the dimensions of the components and precise determination of the experimental conditions allow the coefficient η to be calculated by a formula derived from equation (1), without having recourse to calibration by means of a standard liquid of known viscosity.

The authors use the Louis apparatus [1, 1930, 1931], which is of the capillary-tube type. The formula which applies is that of Poiseuille

$$\eta = \frac{\pi R^4 p t}{8 L V} \quad (2)$$

where π = ratio of circumference to diameter,

R = radius of the tube,

L = length of the tube,

p = pressure producing the flow,

V = volume of liquid discharged in time t .

In order that all these quantities may conveniently be measured the apparatus was designed as shown in Fig. 1. The essential part is a capillary tube, with a bore as uniform as possible, the ends being cut off squarely. Its diameter is determined from the weight of mercury that fills it, the length is measured by a cathetometer. The lower end of this tube dips into a reservoir filled with the liquid under test, the level of the liquid being maintained constant by an overflow. The upper end is joined to the bottom of a Mariotte bottle from which the liquid flows at constant

pressure. The quantity of liquid passing through the tube in time t is collected at the lower end and weighed on a balance. The volume V is then known from the density. The whole arrangement is immersed in a thermostat which must maintain the liquid and the capillary at a definite temperature, constant to at least 0.1°C .

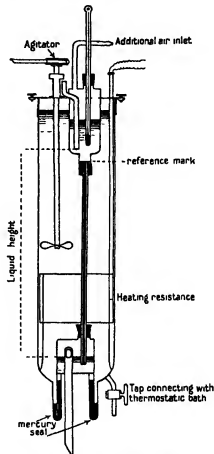

FIG. 1 Absolute viscometer

Equation (2) holds when the liquid issues from the bottom of the tube with negligible kinetic energy, i.e. when p represents the loss of head of the liquid during its passage through the tube. If this were not the case various corrections known by the names of Hagenbach and Couette would need to be applied. It is best to select R to suit η , so that these corrections really are negligible. With these precautions the viscosity of a liquid may be measured with an accuracy of the order of 1%.

Viscometers for Relative Measurements.

These are devised on the same principles as the absolute instruments except that they have been simplified by the omission of arrangements for the convenient measurement of the dimensions. The latter are embraced in one or more constants of the viscometer, determined, once for all,

by means of a liquid of known viscosity. The same precautions are necessary as in absolute measurements for the exact definition of temperature and for the measurements of time and of pressure. If it is desired to avoid kinetic-energy corrections, the rate of flow must be below a certain limit which will be indicated by experiment.

The Petroleum College at Strasbourg has designed and adopted in its measurements an arrangement called the U.F. which is a standardized form of pipette viscometer. The main part is a capillary, with a diameter uniform throughout its length, blown out into a bulb at the top. The bottom of this pipette dips into the liquid of which the viscosity is to be measured; a definite suction is applied to the top of the pipette and the time t taken for the liquid to fill the bulb is measured. The viscometer assembly is immersed in a thermostat bath. The formula employed is

$$\eta = K(H - hp), \quad (3)$$

where H is the suction, in cm., of water,

h is the opposing hydrostatic head, in cm., of the column of liquid raised,

ρ is the specific gravity of the liquid,

K is the constant of the viscometer.

The same instrument may be employed to measure the time t' required for the bulb, previously filled with liquid, to empty by gravity. The formula then becomes

$$\eta/\rho = K't', \quad (4)$$

where K' is a different constant.

The term η/ρ occurs whenever a liquid flows under gravity; it has been given the name *kinematic viscosity*. Some authors refer to it simply as viscosity, but this may lead to confusion with the coefficient η .

In our laboratories the aspiration method of use has been adopted in preference to the gravity flow method for several reasons:

- 1 With very dark liquids it is difficult to see exactly when the bulb has emptied.
- 2 Very viscous liquids leave on the walls of the bulb a film the thickness of which varies with the viscosity, so that the volume running out of the bulb is ill defined; the uncertainty is called the drainage error.
- 3 The aspiration arrangement permits H to be varied; this is extremely valuable in some classes of work.

Calibration of U.F. Instruments.

Calibration consists in the determination of the two constants K and h of formula (3). In the determination of h it is necessary to keep the liquid at a constant temperature throughout the operations so as to be sure that its viscosity remains constant; the actual value of the viscosity need not be known. The time taken for the bulb to empty by gravity is compared with the time required for the same bulb, previously wetted by the liquid, to fill when a certain known suction H is applied. If the two times are t_1 and t_2 , then h is given by the relation

$$H/(hp) - 1 = t_1/t_2$$

Details of the apparatus are so proportioned that the magnitude h is readily defined and reproducible. For the determination of K a standard liquid must be available, of accurately known viscosity. The time is measured that is required for the bulb to be filled with this liquid when a suction H of convenient value is applied. Hence K is deduced according to equation (3). The degree of accuracy is very nearly that with which the absolute viscosity of the standard liquid is known.

Standard Liquids.

The most delicate point in the calibration of relative instruments is the choice and preservation of the standard liquids. These liquids must have been previously studied by means of the absolute apparatus. In order that they may be used in the absolute and relative instruments in such conditions that the kinetic-energy correction is eliminated, there must be available a series of these liquids having viscosities distributed over the whole range of the viscosities employed in practice.

Certain laboratories have hoped to be able to recommend liquids such that a specification of their preparation may suffice to provide substances of known viscosity. Our experience has shown that, except as regards water, which has a very low viscosity, this hope is vain, it is not possible to dispense with a verification of these liquids by means of an absolute viscometer.

In setting up standard liquids of high viscosity two difficulties are encountered:

1 The viscosity of these liquids varies rapidly with temperature, the temperature must, therefore, be very steady and very well known in all measurements. As, however, convection currents are very feeble in viscous liquids and the thermal conductivities are very low, it is extremely difficult to ensure uniformity of temperature; it is this that limits the precision of the measurements.

2 The liquids undergo spontaneous changes at ordinary temperatures and their viscosity varies slowly with time; periodical verification is necessary. This is not to mention pseudo-plastic liquids (*vide infra*), which are utterly unsuitable as standards.

Empirical Apparatus.

The designers of the viscometers for commercial laboratories seem to have shrunk from the use of slow flow, either because it leads to too long experiments or because it requires the measurement of too small volumes. They were led, therefore, to employ short tubes of relatively large diameter in which the mean speed of a filament may even exceed the critical value v_c given by Reynolds' formula

$$v_c R \rho / \eta = 1,000$$

Not only is the kinetic-energy correction no longer negligible, but the flow ceases to be of a laminar nature; formulae deduced from equation (1) are then not applicable. Liquids of increasing viscosity have, it is true, increasing times of flow in such instruments, but there is no proportionality; there is not even, strictly, a universal conversion formula valid for a given type of apparatus.

For the use of such instruments in commerce there may be some case, but there is none in the research laboratory, where the measurement of volumes of a few cm³ is not difficult. In fact it is easier to keep these small quantities than volumes of the order of 100 cm³ at a uniform temperature. We are not interested in this side of the matter.

Pseudo-plasticity.

This term has been mentioned above, we now proceed to define it and to show that it can be revealed and studied only by means of arrangements in which H may be varied and a series of tubes of different diameter may be used.

Some authors refer to liquids showing this phenomenon as 'non-Newtonian'; such liquids do not obey equation (1), and the coefficient η is not a specific constant at a given temperature, but depends on the value of the gradient dv/dx . In the flow of the liquids through tubes, if we vary

the different factors on the right of equation (2), we shall not obtain the same value for η . These facts are well known in the study of colloids, they have been demonstrated in experiments on bitumens, they occur also in some cases among lubricating oils.

Numerous isolated observations have proved that the apparent viscosity of some oils varies with time. Erk and Vogel [2, 1931], on the other hand, have described how certain oils, below a certain temperature, show a viscosity that is not the same when it is observed on a rising as it is on a falling temperature. Lous and Jordachescu [3, 1933] have compared the two phenomena and have studied the question systematically, employing the U F apparatus described above.

An oil was introduced into the viscometer and the latter was kept inside a Dewar flask at intervals, a suitable suction H was applied and the time required to fill the bulb was measured. Most of the experiments were made at the convenient temperature of melting ice, 0°C , but for almost all motor engine oils the phenomenon occurs within a range of several degrees above the setting-point. As a rule the oil becomes turbid during the experiments, but it is not to suspended particles that the anomalies found are due, but to certain types of molecules in the liquid phase (*vide infra*).

Consider, for example, a Pennsylvanian oil described as Veedol V_4 . If this oil stands for a long time at room temperature and is then tested at 0°C , the time required for the bulb to fill increases steadily from the moment this temperature is reached up to a limiting value. The development lasts for some 20 days or so. If the oil has been kept for half an hour at -80°C before putting it into the Dewar flask at 0°C , the filling time is at first greater, but diminishes gradually down to the same limiting value as in the previous experiment. Thus the apparent viscosity, as deduced from formula (3), varies slowly until the liquid has attained to a state of equilibrium at the beginning of the former experiment it was 44.5 poises, while the stable value was 51.6 poises (Fig. 2).

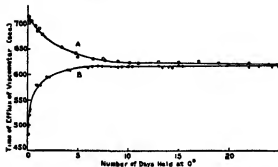

FIG. 2. Variation of viscosity with time. Curve A is for an oil which had been maintained at a temperature of -80°C before the test, curve B is for an oil which had been at room temperature.

The apparent viscosity of certain other oils, cooled quickly from 20 to 0°C , diminished with time, while the liquid became much more turbid than in the above experiments. Turbidity was therefore not the reason for the increase of viscosity of the Pennsylvanian oil in the cases now mentioned there appears to have been slow precipitation of a constituent which was responsible for high viscosity while it was in solution.

The Shape of the Rate of Flow-pressure Curve.

If at each stage of the development several experiments are made quickly with different values of H , it is found that the graph obtained on plotting rate of flow against pressure is not a straight line through the origin, as it is for a normal liquid, but a curve starting from the origin and becoming, sooner or later, indistinguishable from a straight line which when continued backwards cuts the pressure axis at a point P . Many writers have called P the yield value, thinking that they were dealing with true plasticity. As a matter of fact the liquid does flow even at very low values of suction H , we have here an apparent yield value and the phenomenon of pseudo-plasticity. In the last paragraph but one we spoke of apparent viscosity actually the coefficient η is no longer a specific constant for the oil, but it is proportional to the cotangent of the angle between the straight line MO , joining any point on the curve to the origin, and the axis of pressures. Near the origin it is equal to 189.6 poises, but is only 51.6 poises at $p = 210$ cm. During positive development, i.e. that with increase of apparent viscosity, the apparent yield value P increases continually until equilibrium is reached. The opposite occurs during negative development in this case the original pseudo-plasticity must have been due to the substance that separates out from the liquid phase on cooling (Fig. 3).

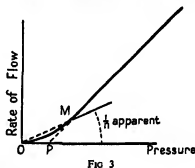

FIG. 3

Thixotropy.

Positive development must be considered as the progressive building-up of a structure in which the molecular orientations and forces are no longer isotropic. Now these structures are fragile and are partially broken down by mere agitation after a rate of flow under suction has been measured, simply forcing the liquid down again by vigorous pressure is enough to give a lower apparent viscosity immediately afterwards. With some oils the phenomenon is so marked as to make it difficult to carry out a good determination of the rate of flow. If they are left undisturbed these liquids start their development again in the same direction as before.

It is thixotropy that is responsible for the fact that when a series of tests is made on a pseudo-plastic oil in tubes of greater and greater diameter, the evidences of pseudo-plasticity become slighter and slighter and finally disappear when a certain diameter is exceeded, there is then no development with time and no apparent yield value P to be observed, so that the liquid seems to be a normal one. Experiments with a Persian oil at 0°C gave the following results:

Diameter of capillary, mm	1.4	1.79	4
Apparent yield value P cm of water	17	8	0 (apparent viscosity 64 poises)

Nevertheless, the phenomenon is still present, thixotropy masking the formation of structures that are too fragile

to withstand the conditions under which the observations are made. It must not be concluded that it will be desirable, for the sake of simplicity, to carry out flow measurements only with wide tubes in which the phenomena of pseudo-plasticity will not appear, nobody knows under what conditions there may be danger of their reappearance in practice. We must have methods for recognizing the property before thinking about how it may be neglected.

Thermal Treatment.

If the oil is subjected to various thermal treatments before it is brought to and maintained at the temperature of experiment, the development of structure and even the final state may be affected. We have seen the effect of a treatment of oil V_4 at -80°C heating it to 50, 60, or 100°C made the development take longer and the pressure P became greater when development was complete. It is thus inevitable that the laws of flow for such products can be little more than approximations.

Elasticity and Rigidity.

Experiments in which a cylinder suspended by a torsion wire is immersed in oil allow us to show the existence of rigidity in material of this kind. Oil V_4 at 0°C , at the end of its development, was found to have a small but definite modulus of elasticity, amounting to 0.251 C.G.S. units. This method is more sensitive than that in which a true yield value of pressure is measured, and it shows clearly that these oils have some properties intermediate between those of true liquids and of solids.

Nature of Pseudo-plastic Molecules.

Although these phenomena have been observed only at relatively high viscosities, a high viscosity is not of itself sufficient to cause them to appear. A 'voltolized' oil of 220 poises at 0°C , for example, showed no signs of pseudo-plasticity. Not only the size of the molecule but its archi-

ecture and environment play a part in these phenomena. It is not a question of paraffin wax separation: normal oils in which wax has been dissolved retain the flow properties of normal liquids even when they are examined at temperatures below those at which they show a marked turbidity owing to precipitation of wax crystals.

On the other hand, an addition of 1% of vaseline to normal oils gives them pseudo-plastic characteristics. Pure vaseline itself at 45°C , near its melting-point, exhibits all the phenomena we have described. If the oil V_4 above mentioned is extracted with ethyl acetate at 0°C , the residue, after the solvent has been driven off from it, shows much more plasticity at 0°C than the original oil: the plasticity is still, however, less than that of vaseline at 45°C . It seems that we have to do with 'lower vasesines', bodies intermediate between vaseline and our Pennsylvanian oil, but little is known of the internal structure of such molecules.

These anomalies of flow occur among substances which for some reason or other exhibit a tendency opposed to that which leads to crystallization. Their molecular state is intermediate between the theoretically perfect isotropy of normal liquids and the strongly marked orientation that is characteristic of crystalline substances.

Conclusions.

We hope that we have shown that

- 1 The phenomenon of pseudo-plasticity is of importance in the physico-chemical examination of the large molecules present in petroleum.
- 2 Capillary viscometers must be available in which the pressure gradient, capillary diameter, &c., may be varied over a wide range.
- 3 Absolute measurements are readily obtainable.
- 4 In the measurement of true viscosities it is essential to avoid conditions in which oils are pseudo-plastic.

REFERENCES

- 1 LOUIS *Congrès du Graissage* (1931)
Soc. Française de Phys. 64 S (1931)
Ann. Off. Nat. Comb. Liq. 949 (1930)

- 2 EAK and VOGEL *Lubrication Cong.*, Strasbourg, 1931
- 3 LOUIS and JORDACHESCU *Proc. World Petr. Cong.* 2, 524 (1933)

SELECTED BIBLIOGRAPHY

- JORDACHESCU Thèse, Université de Strasbourg, 1935
LOUIS *Congrès du Graissage* (1931) *Soc. Française de Physique*, 64 S (1931), *Ann. Off. Nat. Comb. Liq.* 949 (1930) Apparatus for measurement of absolute viscosities
— *Soc. Française de Physique*, 1405 (1932) Contribution to the practical determination of absolute viscosities
LOUIS and DE LA HITE *Congrès du Graissage*, Strasbourg (1931) Study of viscometry

- LOUIS and JORDACHESCU *Proc. World Petr. Cong.* 2, 524 (1933) Anomalous viscosities of oils at low temperature
LOUIS and PEYROT *Ann. Comb. Liq.* 1055 (1932) Contribution to the practical determination of absolute viscosities
LOUIS, THIBAUT, and JORDACHESCU *Physics*, 401 (1933)
WERN, H. *Proc. World Petr. Cong.* 3, 490 (1933) U.F. method of viscosity measurement
WEISS and LOUIS *J. Rheol.* 217 (1932) Approximate calibration of apparatus for measuring absolute viscosity

DENSITY AND REFRACTIVE INDEX DENSITY, GRAVITY, AND SPECIFIC GRAVITY

By D. W. GOULD

The indiscriminate use of the terms 'density', 'gravity', and 'specific gravity' is inconsistent with the advances made in petroleum technology. In order to dispel the present confusion it is necessary to clearly define these terms.

Density.

Density is the mass of unit volume of a substance under any specified conditions. In the case of liquids the temperature must be given and in the case of gases the pressure also. From the definition it is clear that the units in which the mass and the volume are measured must be stated. For instance, the density may be expressed in grams per millilitre on the c g s system, or in the case of gases more usually in grams per litre, or alternatively in pounds per cubic foot on the FPS system. Any other units are permissible provided they are clearly stated, such as pounds per imperial gallon, pounds per U S gallon, kilograms per litre, &c., but density is expressed in c g s units, i e in grams/ml, more frequently than in any other units.

Now the gram is defined as the mass of one millilitre of pure water at 4° C (the temperature of maximum density), so that the density of a substance in grams per millilitre is numerically equal to the ratio of its weight, under the specified conditions, to that of an equal volume of water at 4° C.

A temperature of 20° C is becoming recognized as an international temperature of reference for many purposes, and the density of liquids is very often given at this temperature. Owing to the numerical equality mentioned above it is quite usual to employ the symbol D_{20}^0 or $D_{20}^{20}/4^{\circ}C$ to mean the density of the substance at 20° C in grams per millilitre. This, strictly speaking, is treating density as if it were a specific gravity as described below, but as they are the same by definition in this case there is no ambiguity.

Specific Gravity.

Specific gravity is the ratio of the weight of a substance to the weight of an equal volume of water. Specific gravity is therefore a ratio and has no dimensions, but the temperature at which the specific gravity is measured must obviously be stated, and also the temperature of the water to which it is referred. The standard reference temperature for water is almost invariably 60° F in the petroleum industry, and the specific gravity of an oil at any temperature is usually referred to water at 60° F, but both temperatures should always be stated. The symbols sp gr $t^{\circ}/60^{\circ}F$ is used to mean the specific gravity of an oil at $t^{\circ}F$ referred to water at 60° F.

The density of water at 60° F (15.56° C.) in grams per millilitre is accepted as 0.99904, and therefore the specific gravity of an oil at $t^{\circ}F$, referred to water at 60° F multiplied by 0.99904 is numerically equal to the density of the oil at $t^{\circ}F$ in grams/ml or the specific gravity referred to water at 4° C., which is numerically the same.

If the specific gravity is referred to water at any other temperature, conversion to 60° F (or to 4° C) can readily be made from tables giving the density of water at various temperatures (see Article [4], Appendix D).

In this way specific gravities and densities can be interconverted by means of the accepted properties of water and conversion factors from one set of units to another, provided the oil is measured at the same temperature in each case. However, when the specific gravity of an oil is used as a means of identification, which is one of its chief uses, it is usually measured at 60° F and this is expressed symbolically thus, sp gr 60°/60° F. The temperature of 60° F is in such general use that in the petroleum industry the abbreviation sp gr is often used in place of the longer expression without much ambiguity, but it should always be remembered that the two temperatures should always be stated in case of doubt.

As mentioned above, density is usually given at 20° C, and in such a case it can only be converted to specific gravity at 60° F by a knowledge of the specific gravity correction, density correction, or volume correction for the oil in question over this range. An example of this is given below. When minute differences are of importance it should be noted whether the specific gravities and densities which have been measured, or are to be calculated, refer to weights in air or in *vacuo*. This is usually a matter of the way in which the hydrometer has been calibrated, and reference should be made to another article on this subject [3]. However, it may be said that hydrometers conforming to I P T and A P I specifications refer to weights in *vacuo*, and in that case there are no added complications in the conversions due to the buoyancy of the air displaced. This question, then, only affects the calculation of tonnages from the measured volume of oil with which we are not at present concerned.

In the case of gases, specific gravities are almost invariably given at 60° F and at one standard atmosphere with reference to dry air at the same temperature and pressure. As in the case of liquids, these conditions are often not specified, and the abbreviation sp gr rel air is used to denote this.

Gravity.

The term 'gravity' has come to connote the reading of an arbitrary scale on a hydrometer. The familiar measurements in terms of degrees Baumé, Twaddell, or A.P.I. are without significance as a direct estimation of the density of the material in question, and the perpetuation of the terms is without a single cogent reason.

The API gravity is, however, largely used in the United States and has now displaced the various hydrometer scales of a similar type. As normally used the API gravity refers to a determination of the gravity of the oil at 60° F, and the interconversion of degrees API and of specific gravity is made by the formulae

$$\text{Sp gr } 60^{\circ}/60^{\circ}F = \frac{141.5}{131.5 + \text{API degrees}}$$

$$\text{Degrees API} = \frac{141.5}{\text{Sp gr } 60^{\circ}/60^{\circ}F} - 131.5$$

Table I offers a ready means of conversion

TABLE I Specific Gravity corresponding to Degrees A

Degrees API	Tenths of Degrees									
	0	1	2	3	4	5	6	7	8	9
0	1.0760	1.0752	1.0744	1.0735	1.0727	1.0719	1.0711	1.0703	1.0695	1.0687
1	1.0679	1.0671	1.0663	1.0655	1.0647	1.0639	1.0631	1.0623	1.0615	1.0607
2	1.0599	1.0591	1.0583	1.0575	1.0567	1.0559	1.0551	1.0543	1.0535	1.0528
3	1.0520	1.0512	1.0504	1.0497	1.0489	1.0481	1.0473	1.0465	1.0458	1.0450
4	1.0443	1.0435	1.0427	1.0419	1.0412	1.0404	1.0396	1.0389	1.0381	1.0373
5	1.0366	1.0358	1.0351	1.0343	1.0336	1.0328	1.0320	1.0313	1.0305	1.0298
6	1.0291	1.0283	1.0275	1.0268	1.0261	1.0253	1.0246	1.0238	1.0231	1.0224
7	1.0217	1.0209	1.0201	1.0194	1.0187	1.0179	1.0172	1.0165	1.0157	1.0150
8	1.0143	1.0136	1.0128	1.0121	1.0114	1.0107	1.0099	1.0092	1.0085	1.0078
9	1.0071	1.0064	1.0056	1.0049	1.0042	1.0035	1.0028	1.0021	1.0014	1.0007
10	1.0000	0.9993	0.9986	0.9979	0.9972	0.9965	0.9958	0.9951	0.9944	0.9937
11	0.9930	0.9923	0.9916	0.9909	0.9902	0.9895	0.9888	0.9881	0.9874	0.9868
12	0.9861	0.9854	0.9847	0.9840	0.9833	0.9826	0.9820	0.9813	0.9806	0.9799
13	0.9792	0.9786	0.9779	0.9772	0.9765	0.9759	0.9752	0.9745	0.9738	0.9732
14	0.9723	0.9718	0.9712	0.9705	0.9698	0.9692	0.9685	0.9679	0.9672	0.9665
15	0.9659	0.9652	0.9646	0.9639	0.9632	0.9626	0.9619	0.9613	0.9606	0.9600
16	0.9593	0.9587	0.9580	0.9574	0.9567	0.9561	0.9554	0.9548	0.9542	0.9535
17	0.9529	0.9522	0.9516	0.9509	0.9503	0.9497	0.9490	0.9484	0.9478	0.9471
18	0.9465	0.9459	0.9452	0.9446	0.9440	0.9433	0.9427	0.9421	0.9415	0.9408
19	0.9402	0.9396	0.9390	0.9383	0.9377	0.9371	0.9365	0.9359	0.9352	0.9346
20	0.9340	0.9334	0.9328	0.9322	0.9315	0.9309	0.9303	0.9297	0.9291	0.9285
21	0.9279	0.9273	0.9267	0.9260	0.9254	0.9248	0.9242	0.9236	0.9230	0.9224
22	0.9218	0.9212	0.9206	0.9200	0.9194	0.9188	0.9182	0.9176	0.9170	0.9165
23	0.9159	0.9153	0.9147	0.9141	0.9135	0.9129	0.9123	0.9117	0.9111	0.9106
24	0.9100	0.9094	0.9088	0.9082	0.9076	0.9071	0.9065	0.9059	0.9053	0.9047
25	0.9042	0.9036	0.9030	0.9024	0.9018	0.9013	0.9007	0.9001	0.8996	0.8990
26	0.8984	0.8978	0.8973	0.8967	0.8961	0.8956	0.8950	0.8944	0.8939	0.8933
27	0.8927	0.8922	0.8916	0.8911	0.8905	0.8900	0.8894	0.8888	0.8883	0.8877
28	0.8871	0.8866	0.8860	0.8855	0.8849	0.8844	0.8838	0.8833	0.8827	0.8822
29	0.8817	0.8811	0.8805	0.8800	0.8794	0.8789	0.8783	0.8778	0.8772	0.8767
30	0.8762	0.8756	0.8751	0.8745	0.8740	0.8735	0.8729	0.8724	0.8718	0.8713
31	0.8708	0.8702	0.8697	0.8692	0.8686	0.8681	0.8676	0.8670	0.8665	0.8660
32	0.8654	0.8649	0.8644	0.8639	0.8633	0.8628	0.8623	0.8618	0.8612	0.8607
33	0.8602	0.8597	0.8591	0.8586	0.8581	0.8576	0.8571	0.8565	0.8560	0.8555
34	0.8550	0.8545	0.8540	0.8534	0.8529	0.8524	0.8519	0.8514	0.8509	0.8504
35	0.8498	0.8493	0.8488	0.8483	0.8478	0.8473	0.8468	0.8463	0.8458	0.8453
36	0.8448	0.8443	0.8438	0.8433	0.8428	0.8423	0.8418	0.8413	0.8408	0.8403
37	0.8398	0.8393	0.8388	0.8383	0.8378	0.8373	0.8368	0.8363	0.8358	0.8353
38	0.8348	0.8343	0.8338	0.8333	0.8328	0.8324	0.8319	0.8314	0.8309	0.8304
39	0.8299	0.8294	0.8289	0.8285	0.8280	0.8275	0.8270	0.8265	0.8260	0.8256
40	0.8251	0.8246	0.8241	0.8236	0.8232	0.8227	0.8222	0.8217	0.8212	0.8208
41	0.8203	0.8198	0.8193	0.8189	0.8184	0.8179	0.8174	0.8170	0.8165	0.8160
42	0.8156	0.8151	0.8146	0.8142	0.8137	0.8132	0.8128	0.8123	0.8118	0.8114
43	0.8109	0.8104	0.8100	0.8095	0.8090	0.8086	0.8081	0.8076	0.8072	0.8067
44	0.8063	0.8058	0.8053	0.8049	0.8044	0.8040	0.8035	0.8031	0.8026	0.8022
45	0.8017	0.8012	0.8008	0.8003	0.7999	0.7994	0.7990	0.7985	0.7981	0.7976
46	0.7972	0.7967	0.7963	0.7958	0.7954	0.7949	0.7945	0.7941	0.7936	0.7932
47	0.7927	0.7923	0.7918	0.7914	0.7909	0.7905	0.7901	0.7896	0.7892	0.7887
48	0.7883	0.7879	0.7874	0.7870	0.7865	0.7861	0.7857	0.7852	0.7848	0.7844
49	0.7839	0.7835	0.7831	0.7826	0.7822	0.7818	0.7813	0.7809	0.7805	0.7800
50	0.7796	0.7792	0.7788	0.7783	0.7779	0.7775	0.7770	0.7766	0.7762	0.7758
51	0.7753	0.7749	0.7745	0.7741	0.7736	0.7732	0.7728	0.7724	0.7720	0.7715
52	0.7711	0.7707	0.7703	0.7699	0.7694	0.7690	0.7686	0.7682	0.7678	0.7674
53	0.7669	0.7665	0.7661	0.7657	0.7653	0.7649	0.7645	0.7640	0.7636	0.7632
54	0.7628	0.7624	0.7620	0.7616	0.7612	0.7608	0.7603	0.7599	0.7595	0.7591
55	0.7587	0.7583	0.7579	0.7575	0.7571	0.7567	0.7563	0.7559	0.7555	0.7551
56	0.7547	0.7543	0.7539	0.7535	0.7531	0.7527	0.7523	0.7519	0.7515	0.7511
57	0.7507	0.7503	0.7499	0.7495	0.7491	0.7487	0.7483	0.7479	0.7475	0.7471
58	0.7467	0.7463	0.7459	0.7455	0.7451	0.7447	0.7443	0.7440	0.7436	0.7432
59	0.7428	0.7424	0.7420	0.7416	0.7412	0.7408	0.7405	0.7401	0.7397	0.7393
60	0.7389	0.7385	0.7381	0.7377	0.7374	0.7370	0.7366	0.7362	0.7358	0.7354
61	0.7351	0.7347	0.7343	0.7339	0.7335	0.7332	0.7328	0.7324	0.7320	0.7316
62	0.7313	0.7309	0.7305	0.7301	0.7298	0.7294	0.7290	0.7286	0.7283	0.7279
63	0.7275	0.7271	0.7268	0.7264	0.7260	0.7256	0.7253	0.7249	0.7245	0.7242
64	0.7238	0.7234	0.7230	0.7227	0.7223	0.7219	0.7216	0.7212	0.7208	0.7205

DENSITY, GRAVITY, AND SPECIFIC GRAVITY

1131

TABLE I (cont)

Degrees API	Tenths of Degrees									
	0	1	2	3	4	5	6	7	8	9
65	0.7201	0.7197	0.7194	0.7190	0.7186	0.7183	0.7179	0.7175	0.7172	0.7168
66	0.7165	0.7161	0.7157	0.7154	0.7150	0.7146	0.7143	0.7139	0.7136	0.7132
67	0.7128	0.7125	0.7121	0.7118	0.7114	0.7111	0.7107	0.7103	0.7100	0.7096
68	0.7093	0.7089	0.7086	0.7082	0.7079	0.7075	0.7071	0.7068	0.7064	0.7061
69	0.7057	0.7054	0.7050	0.7047	0.7043	0.7040	0.7036	0.7033	0.7029	0.7026
70	0.7022	0.7019	0.7015	0.7012	0.7008	0.7005	0.7001	0.6998	0.6995	0.6991
71	0.6988	0.6984	0.6981	0.6977	0.6974	0.6970	0.6967	0.6964	0.6960	0.6957
72	0.6953	0.6950	0.6946	0.6943	0.6940	0.6936	0.6933	0.6929	0.6926	0.6923
73	0.6919	0.6916	0.6912	0.6909	0.6906	0.6902	0.6899	0.6896	0.6892	0.6889
74	0.6886	0.6882	0.6879	0.6876	0.6872	0.6869	0.6866	0.6862	0.6859	0.6856
75	0.6852	0.6849	0.6846	0.6842	0.6839	0.6836	0.6832	0.6829	0.6826	0.6823
76	0.6819	0.6816	0.6813	0.6809	0.6806	0.6803	0.6800	0.6796	0.6793	0.6790
77	0.6787	0.6783	0.6780	0.6777	0.6774	0.6770	0.6767	0.6764	0.6761	0.6757
78	0.6754	0.6751	0.6748	0.6745	0.6741	0.6738	0.6735	0.6732	0.6728	0.6725
79	0.6722	0.6719	0.6716	0.6713	0.6709	0.6706	0.6703	0.6700	0.6697	0.6693
80	0.6690	0.6687	0.6684	0.6681	0.6678	0.6675	0.6671	0.6668	0.6665	0.6662
81	0.6659	0.6656	0.6653	0.6649	0.6646	0.6643	0.6640	0.6637	0.6634	0.6631
82	0.6628	0.6625	0.6621	0.6618	0.6615	0.6612	0.6609	0.6606	0.6603	0.6600
83	0.6597	0.6594	0.6591	0.6588	0.6584	0.6581	0.6578	0.6575	0.6572	0.6569
84	0.6566	0.6563	0.6560	0.6557	0.6554	0.6551	0.6548	0.6545	0.6542	0.6539
85	0.6536	0.6533	0.6530	0.6527	0.6524	0.6521	0.6518	0.6515	0.6512	0.6509
86	0.6506	0.6503	0.6500	0.6497	0.6494	0.6491	0.6488	0.6485	0.6482	0.6479
87	0.6476	0.6473	0.6470	0.6467	0.6464	0.6461	0.6458	0.6455	0.6452	0.6449
88	0.6446	0.6444	0.6441	0.6438	0.6435	0.6432	0.6429	0.6426	0.6423	0.6420
89	0.6417	0.6414	0.6411	0.6409	0.6406	0.6403	0.6400	0.6397	0.6394	0.6391
90	0.6388	0.6385	0.6382	0.6380	0.6377	0.6374	0.6371	0.6368	0.6365	0.6362
91	0.6360	0.6357	0.6354	0.6351	0.6348	0.6345	0.6342	0.6340	0.6337	0.6334
92	0.6331	0.6328	0.6325	0.6323	0.6320	0.6317	0.6314	0.6311	0.6309	0.6306
93	0.6303	0.6300	0.6297	0.6294	0.6292	0.6289	0.6286	0.6283	0.6281	0.6278
94	0.6275	0.6272	0.6269	0.6267	0.6264	0.6261	0.6258	0.6256	0.6253	0.6250
95	0.6247	0.6244	0.6242	0.6239	0.6236	0.6233	0.6231	0.6228	0.6225	0.6223
96	0.6220	0.6217	0.6214	0.6212	0.6209	0.6206	0.6203	0.6201	0.6198	0.6195
97	0.6193	0.6190	0.6187	0.6184	0.6182	0.6179	0.6176	0.6174	0.6171	0.6168
98	0.6166	0.6163	0.6160	0.6158	0.6155	0.6152	0.6150	0.6147	0.6144	0.6141
99	0.6159	0.6156	0.6154	0.6151	0.6148	0.6146	0.6143	0.6140	0.6138	0.6135
100	0.6112	0.6110	0.6107	0.6105	0.6102	0.6099	0.6096	0.6094	0.6091	0.6089
101	0.6086	0.6083	0.6081	0.6078	0.6076	0.6073	0.6070	0.6068	0.6065	0.6062
102	0.6060	0.6057	0.6055	0.6052	0.6050	0.6047	0.6044	0.6042	0.6039	0.6037
103	0.6024	0.6022	0.6020	0.6026	0.6024	0.6021	0.6019	0.6016	0.6014	0.6011
104	0.6009	0.6006	0.6003	0.6001	0.5998	0.5995	0.5993	0.5991	0.5988	0.5985
105	0.5983	0.5981	0.5978	0.5976	0.5973	0.5970	0.5968	0.5966	0.5963	0.5960
106	0.5958	0.5955	0.5953	0.5950	0.5948	0.5945	0.5943	0.5940	0.5938	0.5935
107	0.5933	0.5930	0.5928	0.5926	0.5923	0.5920	0.5918	0.5916	0.5913	0.5911
108	0.5908	0.5906	0.5903	0.5901	0.5898	0.5896	0.5893	0.5891	0.5889	0.5886
109	0.5884	0.5881	0.5879	0.5876	0.5874	0.5871	0.5869	0.5867	0.5864	0.5862
110	0.5859	0.5857	0.5854	0.5852	0.5849	0.5847	0.5845	0.5842	0.5840	0.5838
111	0.5835	0.5833	0.5830	0.5828	0.5825	0.5823	0.5821	0.5818	0.5816	0.5813
112	0.5811	0.5809	0.5806	0.5804	0.5802	0.5799	0.5797	0.5794	0.5792	0.5790
113	0.5787	0.5785	0.5783	0.5780	0.5778	0.5776	0.5773	0.5771	0.5768	0.5766
114	0.5764	0.5761	0.5759	0.5756	0.5754	0.5752	0.5750	0.5747	0.5745	0.5743
115	0.5740	0.5738	0.5736	0.5733	0.5731	0.5729	0.5726	0.5724	0.5722	0.5719
116	0.5717	0.5715	0.5713	0.5710	0.5708	0.5706	0.5703	0.5701	0.5699	0.5696
117	0.5694	0.5692	0.5690	0.5687	0.5685	0.5683	0.5681	0.5678	0.5676	0.5674
118	0.5671	0.5669	0.5667	0.5665	0.5662	0.5660	0.5658	0.5656	0.5653	0.5651
119	0.5649	0.5646	0.5644	0.5642	0.5640	0.5638	0.5635	0.5633	0.5631	0.5628
120	0.5626	0.5624	0.5622	0.5620	0.5617	0.5615	0.5613	0.5611	0.5608	0.5606
121	0.5604	0.5602	0.5599	0.5597	0.5595	0.5593	0.5591	0.5589	0.5586	0.5584
122	0.5582	0.5580	0.5578	0.5575	0.5573	0.5571	0.5569	0.5566	0.5564	0.5562
123	0.5560	0.5558	0.5555	0.5553	0.5551	0.5549	0.5547	0.5545	0.5543	0.5540
124	0.5538	0.5536	0.5534	0.5532	0.5530	0.5527	0.5525	0.5523	0.5521	0.5519
125	0.5517	0.5514	0.5512	0.5510	0.5508	0.5506	0.5504	0.5502	0.5499	0.5497
126	0.5495	0.5493	0.5491	0.5489	0.5487	0.5484	0.5482	0.5480	0.5478	0.5476
127	0.5474	0.5472	0.5470	0.5467	0.5465	0.5463	0.5461	0.5459	0.5457	0.5455
128	0.5453	0.5451	0.5448	0.5446	0.5444	0.5442	0.5440	0.5438	0.5436	0.5434
129	0.5432	0.5430	0.5428	0.5426	0.5423	0.5421	0.5419	0.5417	0.5415	0.5413

TABLE I (cont.)

Degrees API	Tenths of Degrees									
	0	1	2	3	4	5	6	7	8	9
130	0.5411	0.5409	0.5407	0.5405	0.5403	0.5401	0.5399	0.5397	0.5395	0.5392
131	0.5390	0.5388	0.5386	0.5384	0.5382	0.5380	0.5378	0.5376	0.5374	0.5372
132	0.5370	0.5368	0.5366	0.5364	0.5362	0.5360	0.5358	0.5355	0.5353	0.5351
133	0.5349	0.5347	0.5345	0.5343	0.5341	0.5339	0.5337	0.5335	0.5333	0.5331
134	0.5329	0.5327	0.5325	0.5323	0.5321	0.5319	0.5317	0.5315	0.5313	0.5311
135	0.5309	0.5307	0.5305	0.5303	0.5301	0.5299	0.5297	0.5295	0.5293	0.5291
136	0.5289	0.5287	0.5285	0.5283	0.5281	0.5279	0.5277	0.5275	0.5273	0.5271
137	0.5269	0.5268	0.5266	0.5264	0.5262	0.5260	0.5258	0.5256	0.5254	0.5252
138	0.5250	0.5248	0.5246	0.5244	0.5242	0.5240	0.5238	0.5236	0.5234	0.5232
139	0.5230	0.5228	0.5227	0.5225	0.5223	0.5221	0.5219	0.5217	0.5215	0.5213
140	0.5211	0.5209	0.5207	0.5205	0.5204	0.5202	0.5200	0.5198	0.5196	0.5194
141	0.5192	0.5190	0.5188	0.5186	0.5184	0.5183	0.5181	0.5179	0.5177	0.5175
142	0.5173	0.5171	0.5169	0.5168	0.5166	0.5164	0.5162	0.5160	0.5158	0.5156
143	0.5154	0.5152	0.5151	0.5149	0.5147	0.5145	0.5143	0.5141	0.5139	0.5137
144	0.5136	0.5134	0.5132	0.5130	0.5128	0.5126	0.5124	0.5123	0.5121	0.5119
145	0.5117	0.5115	0.5113	0.5111	0.5110	0.5108	0.5106	0.5104	0.5102	0.5100
146	0.5099	0.5097	0.5095	0.5093	0.5091	0.5089	0.5088	0.5086	0.5084	0.5082
147	0.5080	0.5078	0.5077	0.5075	0.5073	0.5071	0.5069	0.5067	0.5066	0.5064
148	0.5062	0.5060	0.5058	0.5057	0.5055	0.5053	0.5051	0.5049	0.5048	0.5046
149	0.5044	0.5042	0.5040	0.5039	0.5037	0.5035	0.5033	0.5031	0.5030	0.5028
150	0.5027									

Conversion Factors.

By means of the above formulae and Table I, API gravity, specific gravity, and density can be interconverted, but if the specific gravity or density is required at an oil temperature different from 60° F allowance must be made for the change in volume of the oil with change of temperature. For example, to convert sp gr at 60° F to density in grams/ml. at 20° C,

$$\text{Sp gr } 60^\circ/60^\circ \text{ F. (15.5}^\circ/15.5^\circ \text{ C)}$$

$$\rightarrow D 20^\circ/4^\circ \text{ C (68}^\circ/39.2^\circ \text{ F)}$$

Volume correction at 68° F.

$$\text{Sp gr } 60^\circ/60^\circ \text{ F} \times \frac{\text{Volume correction at } 60^\circ \text{ F}}{\text{Density of water at } 39.2^\circ \text{ F}} = \frac{\text{Density of oil at } 60^\circ \text{ F}}{\text{Density of water at } 60^\circ \text{ F}}$$

Example. The specific gravity of an oil is given as 0.800 (45° API). Referring to the Standard Abridged Volume Correction Table for Petroleum Oils [1], an oil of the above gravity will fall in Group II, a unit volume of the oil at 68° F. will occupy 0.9961 unit volume at 60° F. Reference to standard works shows that the density of water at 60° F. (15.5° C.) is 0.99904 as compared to 1.0000 at 39.2° F. (4° C.) Substituting these values, the density of oil with specific gravity 0.800 is derived

$$D 20^\circ/4^\circ \text{ C.} = \frac{0.800 \times \frac{0.9961}{1.0000}}{0.99904} = 0.797,$$

and conversely, if $D 20^\circ/4^\circ \text{ C} = 0.800$,

$$\text{Sp gr } 60^\circ/60^\circ \text{ F} = \frac{0.800 \times 1.000}{0.99904 \times 0.9961} = 0.804$$

Alternatively, the conversion can be made more directly and often with less error by using the simple specific gravity correction factors such as are given in article [2], which should be consulted. In the example given above, an oil of sp gr 60°/60° F = 0.800 has a sp gr correction factor of 0.00039 per ° F. The specific gravity correction over the range 60° F to 68° F. is therefore 0.00039 × (68 - 60) = 0.0031. This oil will therefore have a sp gr at 68° F. (20° C.) (still with reference to water at 60° F.) of 0.800 - 0.0031 = 0.7969. This is then converted into terms of density in grams/ml at 20° C as indicated above, by multiplying by 0.99904, thus

$$D 20^\circ/4^\circ \text{ C} = [0.800 - (0.00039 \times 8)] \times 0.99904 = 0.7961$$

REFERENCE

1 U S Bur Stds., Circular 154

ARTICLES

2. BNALE Specific Gravity Correction Factor.
3. STOTT Hydrometers

4. WARD, KURTZ, and FULWILER. Density and Refractive Indices

SPECIFIC GRAVITY CORRECTION FACTORS FOR PETROLEUM OILS

By E. S. L. BEALE, M.A., F.Inst.F.
Consultant in Engineering Physics, London

A FAIRLY extensive investigation into the thermal expansion of American petroleum oils was made by the U.S. Bureau of Standards from 1912 to 1915, and the results were published in their Technologic Paper, no 77 [3, 1916]. From these experimental results, which cover the range 0-50° C., an extensive set of tables were calculated for the reduction of volumes and specific gravity to 60° F. These tables are contained in the well-known Circular no 154, entitled *National Standard Petroleum Oil Tables* [4].

These tables have been in general use in the United States for many years and therefore have a strong claim to be the basis for general use, in spite of the fact that the average properties of petroleum oils as marketed to-day would be appreciably different to those of 1916, owing to the advent of cracking.

Table 3 in Circular no 154 is designed for reducing the specific gravity at any temperature observed with a glass hydrometer to 60° F and occupies over 100 pages of print. With this table the observed specific gravity can be reduced to 60° F without calculation, but it has been the established practice in many oil companies to make this reduction by means of a simple specific gravity correction factor which involves only a small amount of arithmetic, and thereby enables one to dispense with elaborate tables, and to use instead a short list of these correction factors. The formula is, of course,

$$S_{60} = G_t + a(t^{\circ} - 60^{\circ} F), \quad (1)$$

where G_t = the specific gravity at $t^{\circ} F$,
and a = the specific gravity correction factor per $^{\circ} F$

Now it should be noted that Circular no 154 is not based on a set of correction factors which remain constant for each oil over the normal temperature range, but on a formula of the type

$$S_{60} = G_t + a(t - 60) + b(t - 60)^2 \quad (2)$$

Clearly, therefore, the average correction factor over the temperature range 60° to $t^{\circ} F$ will vary somewhat with the value of t chosen in cases where b is not zero. In other words, the temperature-specific gravity plot will be somewhat curved. However, by careful choice of the correction factor with regard to the normal working temperature range for its application, the effect of this curvature can be made negligible.

Examination of Table 10 on page 18 of Technologic Paper no 77 shows that the oils with the greatest value of b (equation (2) above) occur at each end of the scale of specific gravities, oils whose gravity lies between 0.780 and 0.840 having a value of b equal to zero. Examples should therefore be chosen from oils of high and low gravities so as to include the worst cases of curvature. An oil having a specific gravity of 0.956 at 60° F may be taken as an example of high gravity oil. This corresponds to an oil of density 0.950 at 25° C., which is the heaviest oil given in Table 10 of Technologic Paper no 77. If a specific gravity correction factor for this oil is chosen so as to give a specific gravity at 120° F., which agrees exactly with the value in

Table 3, it is found to be 0.000345 per $^{\circ} F$. The use of this factor gives differences between the calculated and tabular values at other temperatures, as shown in the following table.

Temperature, $^{\circ} F$	Error in calculated value
30	-0.00035
60	0
90	+0.00015
120	0
150	-0.00005
180	-0.00004
195	-0.0006

This table shows that all errors are negligible and also, incidentally, that the errors are within the limits of accuracy with which Table 3 is calculated, as it is easily shown that with a constant value of b in equation (2) the error should increase more at the higher temperatures than is given in the above table of errors. By choosing a temperature as high as 120° F for zero error in calculating the average correction factor we get negligible error both at high temperatures and at low.

This procedure has therefore been adopted for all oils for which the values are given at 120° F in Table 3. Below 0.726, however, the highest temperature given in the table is 90° F, and the temperature range 60-90° F has therefore been chosen for oils below this gravity, as that over which the mean value of the specific-gravity correction factor is calculated.

An oil with a specific gravity of 0.620 at 60° F may be taken as the example of a light oil, as this is nearly the lightest oil given in Table 3. From the table the specific gravity at 90° F is 0.6035, which gives an average correction factor of 0.00055 per $^{\circ} F$. Calculating the specific gravity at various temperatures with this factor, and comparing the values with those from Table 3, we get the following differences, which are again found to be negligible.

Temperature, $^{\circ} F$	Error in calculated value
30	+0.00010
60	0
75	+0.00005
90	0

Construction of Table of Correction Factors

Having established that it is possible to use a fixed value for the specific-gravity correction factor for each oil which will represent Table 3 of Circular no 154 with the required accuracy, the correction factors calculated in this way from the specific gravities in Table 3 at the following pairs of temperatures are shown plotted in Fig 1 [2, 1937] against the specific gravity at 60° F.

Oils of sp gr 0.726 and heavier	60-120° F
Oils lighter than 0.726	60-90° F

For general use it is undesirable to have more than two

significant figures in the correction factor for simplicity in calculation, and, furthermore, a higher degree of accuracy than this is not justified by the data on which these figures are based. This does not imply that the experimental work is inaccurate, but that the variation between oils of different types is greater than error of approximating in this way

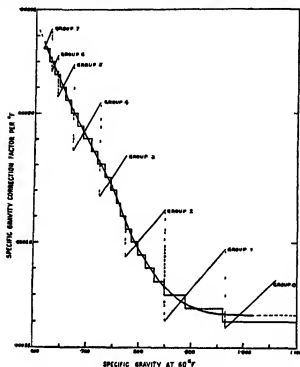

FIG 1 Variation of specific gravity correction factor with specific gravity

The correction factors in the following table [2, 1937] have therefore been given to two significant figures only, and the range of specific gravity over which each factor is applicable is given to three figures. The specific-gravity range for each step in the correction factor has been taken from a large-scale graph similar to Fig 1 so as to give the minimum deviation on each side of the smooth curve. In this way the departure from the smooth curve is never more than 0.000005, whereas, if the specific-gravity range were also approximated to two figures, the departure would be double or treble this amount in places.

The curve representing the Bureau of Standards figures is for use with a glass hydrometer. When calculating tonnage, the Bureau of Standards figures should really be corrected for use in steel tanks, but the difference between the correction factor in glass and in steel is not large (0.000003 to 0.000005 per °F), and it has been thought best to leave them unaltered.

The only influence this consideration has had in the preparation of the following table of correction factors is in deciding to approximate the value of 0.000345 for high-gravity oils to 0.00034 instead of 0.00035.

The A.S.T.M. Abridged Volume Correction Table

There is another method by which the necessary temperature correction can be applied without the use of the elaborate tables in Circular no 154, namely, by using the Abridged Volume Correction Table issued by the A S T M [1, 1934]. This table is based on exactly the same data as

Circular no 154, but in the process of abridgement very substantial errors are introduced, and it is desirable that these inaccuracies should be generally realized.

A Table of Specific-gravity Correction Factors for Petroleum Products

Specific gravity at 60° F	Correction factor per ° F
Over 615 to 625	0 00055
" 625 " 635	0 00054
" 635 " 645	0 00053
" 645 " 656	0 00052
" 656 " 667	0 00051
" 667 " 680	0 00050
" 680 " 692	0 00049
" 692 " 707	0 00048
" 707 " 720	0 00047
" 720 " 734	0 00046
" 734 " 746	0 00045
" 746 " 756	0 00044
" 756 " 765	0 00043
" 765 " 775	0 00042
" 775 " 786	0 00041
" 786 " 798	0 00040
" 798 " 814	0 00039
" 814 " 830	0 00038
" 830 " 850	0 00037
" 850 " 890	0 00036
" 890 " 960	0 00035
" 960 and over	0 00034

In order to reduce the size of the tables in Circular no 154, oils have been divided into eight groups according to specific gravity, and a given coefficient of expansion is used for each group. By limiting the number of groups to eight a considerable error is introduced due to attributing the same characteristics to the oils at the two ends of a relatively large group as to those at the middle.

This much is clear from general considerations, but unfortunately the fact that the coefficient of expansion is the basis for such a table and not the specific-gravity correction makes this effect very much more serious. This can best be seen by converting the coefficients of expansion used in this abridged table to specific-gravity correction factors and plotting the result against the true figures from Circular no 154 which is based on the same data.

This has been done in Fig 1. It will be seen that, whereas the true correction factor decreases with rising specific gravity, the assumed correction factors within each group increases with rising specific gravity. This results in a very substantial error in the assumed correction factor at the ends of the groups.

As an example, if the volume of an oil at the junction of Groups 1 and 2 is read from the abridged table for 149° F, which is the maximum temperature range given, we get

for Group 1	0 9651
for Group 2	0 9558,

which differ by nearly 0.010, or 1%.

It will be readily seen that, apart from the relatively large steps adopted for the table, the main cause of error is the discrepancy in slope between the true and assumed correction factors. It naturally follows, therefore, that if a constant value of the specific-gravity correction factor is used for each group giving horizontal steps on the diagram, this discrepancy is very greatly reduced, particularly for the higher gravity oils where the true curve is itself horizontal. Unfortunately, unless the coefficient of expansion is taken to be constant for each group, a short table of volume

corrections cannot be compiled, so that we can say that a short and accurate table of this type is impossible.

It appears, therefore, that the use of a standard table of specific gravity correction factors such as the one given above is to be recommended in preference to any abridged volume correction table.

Waxy Oils

There is one important fact in connexion with the use of specific-gravity correction factors or conversion tables of any kind which should be more generally appreciated, namely, that the correction factor of most waxy oils is far from being constant over the normal temperature range at which this is applied. This is due to the change in volume of the wax which crystallizes from solution as the oil is cooled, resulting in a very considerable increase in the apparent specific-gravity correction factor at low temperatures.

The values given in Circular no. 154, on which the above table of correction factors is based, refer to the change in specific gravity of the oil itself and agree well with the behaviour of waxy oils at the higher temperatures where all the wax is in solution.

A moderately waxy fuel oil of sp. gr. 0.925 may have a correction factor of 0.0034 per °F at temperatures above 130° F., whereas at 60° F. the correction factor for the same oil may be over 0.0045 per °F., as shown in Fig. 2 [2, 1937]. If the specific gravity of an oil of this type is

corrected from 130° to 60° F. by means of the normal factors suitable for non-waxy oils, the error will be in the region of 0.004 in specific gravity.

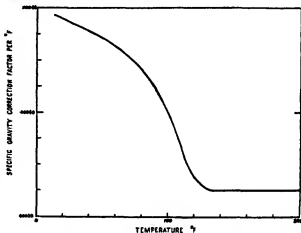

Fig. 2 Variation of specific gravity correction factor with temperature

It is clear, therefore, that for tonnage calculations the specific gravity of waxy oils should be measured close to the temperature at which it is required, so as to avoid the very substantial error involved in correcting over a wide temperature range.

REFERENCES

- 1 ASTM Revised ASTM Standard Abridged Correction Table for Petroleum Oils ASTM Designation D 206 (1934)
- 2 BEALE, E. S. L. *J.I.P.T.* 23, No. 161, 213-19 (Mar. 1937)
- 3 Bureau of Standards Technologic Paper no. 77 (Aug. 1916)
- 4 Circular no. 154 *National Standard Petroleum Oil Tables*

CORRECTION OF THE DENSITY AND REFRACTIVE INDEX OF HYDROCARBONS FOR TEMPERATURE

By E. S. L. BEALE, M.A., F.Inst.P., *Consultant in Engineering Physics*, and T. K. HANSON, B.A.

It is often necessary to convert the density of hydrocarbons, such as occur in petroleum, from the temperature of observation to the temperature at which the density is given in the literature so as to allow a comparison to be made. The same thing applies to the refractive index which is often used for identification purposes. Owing to the approximate constancy of the specific refraction of Gladstone and Dale, $(n-1)/d$, or, alternatively, one of the more

As the correction has only to be applied over quite a limited temperature range in the majority of cases, the error in the corrected density or refractive index will usually be within the limits of accuracy at the determination.

The data on which Fig. 1 is based comes primarily from the *International Critical Tables*, supplemented where necessary by data from *Tables Annuelles* and Landolt's *Tables*. The coefficient of expansion at 20° C has been

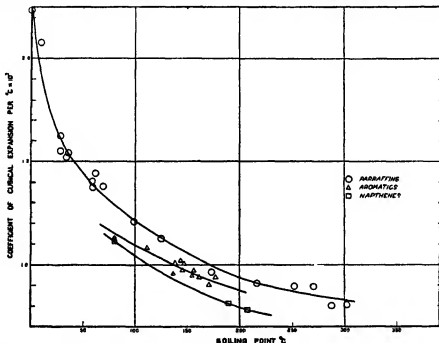

FIG. 1

complicated expressions for this property, such as that of Lorentz and Lorentz $\left(\frac{n^2-1}{n^2+2}\right) \frac{1}{d}$, or that of Eykman $\left(\frac{n^2-1}{n+0.4}\right) \frac{1}{d^2}$ if a satisfactory method of converting the density can be found, it can also quite simply be applied to correcting the refractive index with sufficient accuracy over small temperature ranges.

It is found that if the density correction factors for pure hydrocarbons are plotted, the variation between the different types is large and, owing to the limited number of points available, it is difficult to extrapolate most of the curves. On the other hand, if the cubical expansion is plotted against the boiling-point at atmospheric pressure, a more satisfactory set of curves is obtained which lie close together and may be extrapolated with some confidence. These are shown on Fig. 1, from which it will be seen that the difference between the aromatics and the paraffins is only about 10% and, therefore, the ambiguity in the case of hydrocarbons whose structure is intermediate between these extremes is not likely to be more than about 3 or 4%.

plotted, and therefore the density correction factor at 20° C is obtained as follows:

$$\text{Coeff of cu expansion at } 20^\circ \text{ C per } ^\circ \text{C.} \\ = \frac{\text{Density corr factor per } ^\circ \text{C}}{\text{Density at } 20^\circ \text{ C.}}$$

Over a short range of temperature the density correction factor may be taken as constant. It is also usually quite accurate enough when correcting the density from $t^\circ \text{ C.}$ to 20° C, for instance, to use the density at $t^\circ \text{ C.}$ in the above equation instead of the density at 20° C.

All the densities of the pure hydrocarbons given in the *Table of Physical Properties* [1] which were given in the literature at other temperatures were converted to 20° C. by the use of Fig. 1, and the refractive indices were corrected where necessary to 20° C. in a similar way, using Gladstone and Dale's formula for the specific refraction, as the temperature range was in all cases small enough for this simple expression to give the required accuracy.

REFERENCE

- 1 Article entitled "The Properties of Pure Hydrocarbons", by G. L. Eston

DETERMINATION OF DENSITY AND REFRACTIVE INDEX OF HYDROCARBONS AND PETROLEUM PRODUCTS

By A. L. WARD, *Manager, The Chemical Laboratories, The United Gas Improvement Company*
S. S. KURTZ, Jr., *Development Engineer, The Sun Oil Company,* and W. H. FULWEILER, *Consulting Chemical Engineer*

1. GENERAL DISCUSSION

Introduction.

Density and refractive index are two physical properties which can be readily determined to a relatively high degree of accuracy. Both properties are of great value in the examination of petroleum products, and are so intimately related to each other that they should be discussed together. In this way, proper emphasis may be placed on their mutual relations and on their use in the analysis and identification of hydrocarbons.

Density is defined as mass per unit volume and has the dimensions ML^{-3} . It is, therefore, dependent upon the units used. Grams per millilitre (1 gram per millilitre = 0.999973 g per c.c.), pounds per gallon, pounds per cubic foot (1 lb per cu ft = 0.016018 g per c.c.) are all units of density. In order to be precise, therefore, it is necessary to specify the units used. However, the usage of the term 'density' to mean grams per millilitre for liquids and grams per litre for gases has become so commonplace that these meanings may be assumed unless other units are specified. Since the litre is the accepted unit of volume on the metric system, volumes should always be expressed in millilitres (abbreviated to ml) in preference to cubic centimetres (c.c.).

Specific Gravity (also called specific density or relative density) is the ratio of the weight of a given volume of the material to the weight of an equal volume of a standard substance under specified conditions. In the case of gases, air is usually the standard substance. In the case of liquids and solids, water is the standard used. Specific gravity is a pure number and is independent of the units used.

The formula for specific gravity is $sp\ gr\ t/t' = w'/w$, where w' and w are the weights of equal volumes of the sample and of water at the temperature t' and t respectively. Specific gravity $60^\circ F/60^\circ F$ is frequently used in industrial work, but in scientific work specific gravity $20^\circ C/4^\circ C$ is very generally used, and this is numerically equal to true density in grams per millilitre.

The technical requirements of certain industries have resulted in the use of the adjectives 'absolute', 'true', 'apparent', 'bulk' as applied to specific gravity. These special terms are well covered in the definitions of the American Society for Testing Materials [7, 1927].

Gravity is specific gravity in some arbitrary scale.

For the petroleum industry in the United States the definition [5, 1933] of specific gravity is as follows:

'Specific Gravity. The Specific Gravity of a petroleum oil and of mixtures of petroleum products with other substances is the ratio of the weight of a given volume of the material at a temperature of $60^\circ F$ ($15.56^\circ C$) to the weight of an equal volume of distilled water at the same temperature, both weights being corrected for the buoyancy of the air.'

Gravity. The A.P.I. gravity scale is an arbitrary one which is related to the specific gravity of a petroleum oil in accordance with the formula:

$$\text{Degrees API} = \frac{141.5}{sp\ gr\ 60^\circ/60^\circ F} - 131.5$$

In Great Britain the use of specific gravity is the established custom. The correction for buoyancy of air is applied only when accuracy to the fourth decimal place is required [39, 1935].

Methods of Determining Density and Specific Gravity.

Density being weight per unit volume and specific gravity being the ratio of the weights of equal volumes, the methods used depend (1) upon the direct weighing of a known volume of the substance (pycnometer method), (2) upon the loss of weight of a plummet of known volume when immersed in the liquid (density balance), (3) upon the volume displaced by a float of known weight (hydrometer), (4) upon the submerged equilibrium, i.e. submerged floating, of a bulb of known density. In addition to the above general methods there are a number of special methods used for gases, liquefied gases, solid and semi-solid asphalts, &c.

There are three factors that must receive attention to ensure accuracy: (1) temperature control, (2) correction of weights for air buoyancy, (3) constancy of volume of the container.

(1) Inadequate or inaccurate temperature control is probably the largest single source of error. With petroleum products the coefficient of expansion varies with the specific gravity and the error introduced by the variation of one degree F and C is approximately as follows:

Specific gravity $60^\circ/60^\circ F$	0.60	0.70	0.80	0.90	1.0
Change for $1^\circ C$	0.0010	0.00087	0.00072	0.00067	0.00061
Change for $1^\circ F$	0.00057	0.00048	0.00040	0.00037	0.00034

This indicates the necessity for accurate thermometers and thermometry.

(2) For accurate scientific work all weights must be corrected for the buoyancy of air, and such corrections are also included in the definition of specific gravity used by the American Petroleum Industry. The following simple formula is adequate for making this correction.

$$m = s + (V_m - V_a)d$$

where

m = weight in vacuum in grams,

s = apparent weight in air against brass weights,

V_m = volume of the material weighed in ml,

V_a = volume of the brass weights (8.4 density),

d = density of air (0.0012 g per ml at $20^\circ C$, 760 mm Hg, and 50% relative humidity)

The effect of neglecting this correction is shown in the following table:

Density $20^\circ/4^\circ C$ ± per ml	0.5	0.6	0.7	0.8	0.9	1.0
Correction to be added to determination in air	0.06000	0.00048	0.00036	0.00024	0.00012	0.0000

(3) The change in volume of the container or plummet when the temperatures used differ from that at which the standard substance is weighed or the apparatus calibrated, will introduce a small correction. The cubical expansion of soft glass may be taken as 0.000024 and of Pyrex as 0.0000096 ml/ml/°C. A difference of 10°C will change the volume of 0.024% and 0.0096% respectively, resulting in a correction of 0.0002 and 0.0001 in the density of a substance having a density of 1.0.

In most technical work it is not necessary to apply either the correction for air density or for the expansion of glass, the apparent weight when weighed in air against brass weights of 8.4 density being used. Technical density measurements on liquids may be expected to be reproducible within ± 0.0005 , and to have an absolute accuracy within ± 0.001 . Greater accuracy than this requires extremely precise technique and careful application of necessary corrections.

1. Pycnometers.

All forms of volumetric containers which can be first filled with water and weighed and subsequently filled with the liquid under examination and again weighed may be included under this general head.

For work of medium accuracy an ordinary volumetric flask of 25 to 50 ml capacity may be used.

Usually the term 'pycnometer' is reserved for apparatus designed for determination of density only. Two types of pycnometers are in general use, the 'specific gravity bottle' type and the weighing-tube type, usually called the Ostwald or Sprengler pycnometer. The specific gravity bottle type of pycnometer is an attempt to improve on the volumetric flask by providing a stopper with a hole in it which is pushed into the liquid, forcing the excess out through the hole and around the ground glass joint. This method of obtaining a uniform volume is convenient, but not very accurate. For a fuller treatment of pycnometers, see Wade and Merriman [71, 1912].

The Ostwald or Sprengler pycnometer may be filled with great accuracy, and, with care in regard to experimental technique and corrections, is suitable for determining densities to 0.00001 g/ml. This type of pycnometer is first filled with slightly more than the desired volume of liquid, it is then suspended in a constant temperature bath so that the bulb is immersed and the arms are just above the surface of the bath liquid. After coming to temperature, filter-paper is applied to the pointed tip and liquid is sucked out until the meniscus in the other arm reaches the calibration line. It is then removed from the bath, dried, and weighed. Determinations in which the filling and adjustment to volume are both made at room temperature can be made rapidly.

This type of pycnometer usually is designed for 5 to 10 ml volume, but can be modified for the determination of density on samples at not over 0.3 ml. For work with volatile compounds the pycnometer arms are equipped with ground glass caps.

In order to eliminate corrections for buoyancy of air on the pycnometer, one may advantageously use a counterpoise equal in volume to the full pycnometer. For a discussion of this type of pycnometer see Richards and Chadwell [58, 1925], and Hartley and Barrett [28, 1911].

2. Density Balance or Westphal Balance.

An ordinary analytical balance may be adapted for the determination of density by the use of a plummet of known

volume. The plummet is hung from the balance arm by a fine wire, weighed in air, and then weighed while immersed in water. The loss in weight of the plummet divided by its volume gives the density. This is the basis of one of the A S T M methods for solid hydrocarbons [3, 1927]. In this modification a cube of the solid hydrocarbon becomes the plummet.

The Westphal balance is based on the same principle but is designed so that the density may be read directly as the sum of the weights hung on the balance arm.

The 'Chaunomatic' style Westphal balances are especially well suited for making reasonably accurate measurements with great rapidity.

This type of balance usually requires at least 25 ml of liquid. It is especially useful for rapid and reasonably accurate determination of the densities of cuts obtained from a laboratory fractionating column. Densities are indicated to the fourth decimal place, although the accuracy will not be better than ± 0.001 g/ml unless all precautions are observed in calibration and temperature control [67, 1916].

3. Hydrometers.

The hydrometer is the classical method for determining gravity in the petroleum industry. An hydrometer is a bulb of known weight having a long, narrow cylindrical stem. When placed in a cylinder of liquid the hydrometer sinks until the volume of liquid displaced is sufficient to equal the weight of the hydrometer. The stem of the hydrometer could be calibrated in terms of volume immersed, but it is more convenient to calibrate in terms of density, or some function of density.

The usual petroleum hydrometers are calibrated for a range of 10° API in 0.1° API intervals. One-tenth ° API is equivalent to 0.0004 sp gr 60/60 at 60° API, and to 0.0006 sp gr 60/60 at 20° API. For most petroleum products one may therefore use the approximate relation 0.1° API = 0.0005 sp gr 60/60. Since $\pm 0.1^\circ$ API is considered a reasonable tolerance on the corrected gravity, it is clear that commercial petroleum gravities are reproducible to about 1 in the third decimal place of the density.

The hydrometer just described requires approximately 250 ml of liquid for proper immersion. Use of a tube of smaller diameter than a 250 ml cylinder is undesirable because of the effect of surface-tension which introduces an appreciable error.

Hydrometers are not well adapted for accurate measurement on small samples, for the small hydrometers are not as accurate as the larger ones.

The I P T Standard Methods of Testing Petroleum and its Products [39, 1935] provide a very useful table giving recommended dimensions for various types of hydrometers.

The A S T M Standard Method of Test for Gravity of Petroleum and Petroleum Products [5, 1933] covers the use of the hydrometer and includes a very useful table giving specific gravities, pounds per gallon and gallons per pound corresponding to degrees API given in Appendix A.

The standard tables for the volume correction of petroleum products and both volume correction and specific gravity correction for creosote and coke-oven tar and admixtures are given in Appendices B and C.

Although hydrometers may be and sometimes are graduated to read specific gravity directly, in many cases arbitrary scales were established and the readings were known as degrees Baumé, Brx, Cartier, Twaddell, &c.

One of the more generally used scales, especially in the petroleum industry, was known as the Baumé scale. Originally used at a temperature of $10^{\circ} R = 12^{\circ} C = 54^{\circ} F$ for liquids lighter than water, the zero of the scale was set at the point given by a 10% solution of NaCl in water and the 10° point as that for pure water. The scale then extended to 50° in terms of this fundamental interval.

The readings of the different instruments may be reduced to specific gravity by means of a formula which includes a constant known as the modulus in the form

$$\text{Specific gravity} = \frac{\text{Modulus}}{\text{Modulus} - \text{reading for water}} + \text{Reading}$$

The various scales may then be compared by means of this constant

Unfortunately the makers of hydrometers did not all adopt the same value for the modulus, so that there was little uniformity in the resultant readings.

In an article [65, 1914] on the history of the modulus used in calibrating hydrometers for the petroleum industry, Mr C J Tagliabue refers to some 15 values found in the literature that vary from 131.07 to 146.0. Mr Tagliabue points out that the set of hydrometers that were adopted as standard by the United States Petroleum Association on 2 May 1864 were made by his predecessor, Mr J Arnaboldi, and were calibrated using as a modulus 141.5, and that the petroleum industry has used this figure ever since.

When the National Bureau of Standards began testing hydrometers in 1904 it adopted as a standard the figure 140. This gives a difference scale, as may be seen from the table below.

Modulus	140	0	10	20	30	40	50	60	70	80
Modulus	141.5	10	20	30	40	50	60	70	80	90
Modulus	80	90	100	110	120	130	140	150	160	170
Modulus	80.75	90.86	100.96	111.06	121.16	131.26	141.36	151.46	161.56	171.66

The difference between these two scales gave rise to considerable discussion over a number of years. In 1921, at the instance of the American Petroleum Institute, the Bureau of Standards agreed to accept the value of 141.5 for hydrometers to be used for petroleum, with the proviso that the readings were to be known as degrees API to prevent confusion with the scale based on 140.0. The API scale has been adopted as standard by all of the Government and other standardizing bodies in the United States.

4. Submerged Float Method.

This method depends upon the preparation of floats of accurately known weight and volume which are placed in the liquid under examination at known temperatures. Those floats that are more dense than the liquid, sink. Those lighter than the liquid, float. The float that has a density identical with the liquid will remain suspended at any point in the liquid.

This method, with refinements, is said to be accurate to ± 0.000005 g/ml [55, 1925] using a float of 2-3 ml volume.

This method has been used in a preliminary way for visual determination of the density of liquefied gas in small glass tubes and for the determination of densities at very high temperatures [24].

In addition to the specific references given, the following general works of Kohrausch [43, 1935], Ostwald-Luther-Drucker [55, 1925], and Farkas [23, 1935] should be consulted.

5. Special Methods of Determining Density Used for Liquefied Gases, Asphalts, &c.

(a) **Liquefied Gases** [54, 1933] The Natural Gas Association of America has proposed a method of determining the liquid density of the liquefied hydrocarbon gases which are so widely used commercially. The equipment needed is as follows:

- (1) A torsion balance capable of weighing 15 lb accurately to 0.001 lb
- (2) A bomb of steel 3 in in diameter and 12 in long having two liquid education-pipes and equipped with an accurate gauge registering up to 500 lb/sq in
- (3) A water-bath in which the bomb may be immersed

Three weights are obtained

- (1) Weight of evacuated bomb
- (2) Weight of bomb full of water exerting 100 lb/sq in pressure due to liquid expansions at $60^{\circ} F$
- (3) Weight of bomb full of liquefied gas exerting double the vapour pressure of product due to liquid expansion at $60^{\circ} F$

The weight of liquefied gas divided by the weight of water is the liquefied gas specific gravity. It is reported as sp gr $60^{\circ} F/60^{\circ} F$. Duplicate determinations should check within 0.0008.

The Natural Gas Association procedure specifies all details of manipulation exactly and should be consulted by any one intending to use this method.

A term frequently encountered in connexion with liquefied gas transportation is 'filling density', which is the maximum permissible value of the ratio

$$\frac{\text{(weight of gas charged in container)}}{\text{(weight of water which container will hold)}}$$

In general this is 10-25% less than the true density of the liquefied gas at $60^{\circ} F$. For detailed information on shipping containers, &c, consult Bureau of Explosives, 30 Vesey Street, New York City.

(b) **Road Oils, Road Tars, Asphalt, Cements, and Soft Tar Pitches** [2, 1927] The determination is made in a weighing-bottle of specified dimensions provided with an accurately fitting glass stopper with a hole of 1.5-1.7 mm bore in place of the usual capillary opening. The lower part of the stopper is made concave in order to allow air-bubbles to escape through the bore.

The following determinations are made for an oil or tar which flows readily

$$\begin{aligned} \text{Weight of bottle empty} &= a \\ \text{Weight of bottle filled with water at } 25^{\circ} C &= b \\ \text{Weight of bottle filled with sample at } 25^{\circ} C &= c \\ \text{From these weights, sp gr } 25^{\circ} C/25^{\circ} C &= \frac{c-a}{b-a} \end{aligned}$$

When a sample which will not flow readily is being tested, it may be brought to a fluid condition by gentle warming. The bottle is then about half-filled with the sample, and after cooling to room temperature is weighed. The weight is called c . The bottle is then completely filled with water. The weight of the bottle plus sample plus water at $25^{\circ} C$ is called d . Then

$$\text{sp gr } 25^{\circ} C/25^{\circ} C = \frac{c-a}{(b-a)-(d-c)}$$

When it is not desired to melt a sample that is solid at $25^{\circ} C$, fragments may be placed in the bottle and c deter-

mmed. After covering the sample with water, a funnel is inverted over the bottle and suction is applied for a few minutes to remove any air-bubbles adhering to the sample. The bottle is then completely filled, brought to temperature, and weighed.

An alternative method [3, 1927] for samples which are sufficiently solid to be handled in fragments is to mould the sample into a cube $\frac{1}{2}$ in on each edge, suspend the cube on a thread, and weigh first in air and then in water at 25°. The method is accurate to ± 0.005 .

Refractive Index.

1. **Definition and Symbols.** Refractive index is the ratio of the speed of light in space (vacuum) to its speed in a given substance. The usual symbol is n and is expressed as

$$n = \frac{\text{velocity in space}}{\text{velocity in substance}}$$

This is known as the absolute refractive index.

In technical work, however, air is used as the reference medium and the refractive index relative to air may be converted to absolute refractive index by multiplying by the absolute refractive index of air under the experimental conditions. The absolute index of dry air containing 0.03% CO₂ at 760 mm of Hg and at 0°, 15°, and 30° C are 1.000292, 1.000276, and 1.000263 respectively [38, 1930]. For very precise work (1×10^{-6}) the temperature, pressure, humidity, and composition of the air must therefore be given consideration. In any medium the refractive index varies with the wave-length of the light. This property, the measurement of which is the difference in indices for two wave-lengths, is known as dispersion. It is necessary, therefore, to specify the wave-length for which refractive index is determined, and for comparative purposes, to use standard wave-lengths.

In scientific work spectral lines are the usual source of illumination in the determination of refractive index. By using the symbol of the spectral line as a subscript to the symbol n , the wave-length used is specified. Thus n_D means refractive index determined for light of 4,861 Å units (see below).

The temperature at which the determination is made is written above the line symbol. Thus n_D^{20} means refractive index determined at 20° C for the sodium D line. The latter line was readily available to early experimenters and many refractive indices for this line have been determined. A very generally used instrument (the Abbé), although designed to be operated with white light, is calibrated to give readings in terms of the D line of sodium. In industry the expression $R.I.$ is commonly used to denote refractive index for the D line.

Table I gives the designation, source, and wave-length of the spectral lines commonly used for refractive index. It should be noted that usage in regard to the small identifying letters for the lines that are not in the Fraunhofer solar spectrum is not entirely uniform. To prevent ambiguity, therefore, it is preferable to specify the wave-length.

In the past the common source of the D line has been a flame in which a sodium salt was volatilized. The invention of the electrically operated sodium vapour lamp has provided a more convenient, powerful, and constant source of this line. The common source of the spectral lines of helium, hydrogen, and other gases is a closed Geissler tube containing the gas in question. As pointed out by Ward and Fulweiler [72, 1934], a very convenient source of the mercury lines is an open-arm Geissler tube connected to

both a vacuum pump and an automatic electrolytic hydrogen generator. Aluminum electrodes are used and a small amount of mercury is added to each bulb. When the tube is in use, the pump is operated continuously and just enough hydrogen is added to give the maximum illumination. The mercury g line (4,358 Å) so obtained is more brilliant than the hydrogen G' line (4,341 Å) as obtained with ordinary equipment.

TABLE I
Spectral Lines used for Determination of Refractive Index and of Refractive Dispersion

Description of line		Wave-length in Angstrom units	Colour
Identifying letter	Element by which emitted	($1 = 10^{-10}$ metre)	
r	helium	6,678	red
C or $H\alpha$	hydrogen	6,563	"
D_1	sodium	5,896	yellow
D_2	"	5,890	"
D	"	5,893	"
L	helium	5,876	"
e	mercury	5,461	green
v	helium	5,016	greenish-blue
F or $H\beta$	hydrogen	4,861	"
c	helium	4,713	"
i	"	4,471	blue
g	mercury	4,358	"
G' or $H\gamma$	hydrogen	4,340	"
h or $H\delta$	"	4,102	indigo

It is difficult to distinguish between the two sodium lines D_1 and D_2 . For that reason the average wave-length of 5,893 Å is distinguished as D . This is the wave-length for which refractive index data are ordinarily compiled. However, the difference of 6 Å between D_1 and D_2 is of significance for precise work. In the case of hexane and benzene, for example, it is equivalent to a variation in n of 0.00002 and 0.00005 respectively. In work of high precision use of the average D line may, therefore, result in an error of 0.000025 in the case of benzene, particularly since the intensity of the two lines in question is different.

To eliminate any ambiguity about the wave-lengths of sodium, many careful investigators refuse to use the D line. For example, Eykman [21, 1919] in his later work reported precise values for ten other wave-lengths but not for the D line. For the correlation of such index data with other data reported for the D line and also for other purposes, it is frequently necessary to extrapolate indices or to interpolate them between two wave-lengths. Several devices are available for this purpose, which is in reality the calculation of dispersion for the wave-lengths in question.

2. **Dispersion.** The property of dispersion, which was known even before Newton, is of importance not only from a practical point of view but because of its theoretical interest. The theoretical significance has received much attention because of its importance in the study of both the theories of light and the constitution of matter. The subject is beyond the scope of the present treatise, but the literature will be summarized very briefly for the benefit of those desiring to study the subject further.

Two of the earliest workers were Cauchy [12, 1836] and Sellmeier [62, 1871]. Both of these pioneers developed formulae that are still used to-day. Other early workers were Kettler [42, 1870], Helmholtz [30, 1875, 31, 1893], Kolacsek [44, 1887], Kundt [46, 1888], L. Lorenz [53, 1880], and H. A. Lorentz [52, 1880]. The theories of Lorenz and Lorentz resulted in a formula that is still used and will be

discussed in a later section on refractivity. Mention must also be made of the work of Drude [19, 1893] and Voigt [70, 1899]. A useful summary of the early work has been made by Wood [74, 1914].

With the development of the quantum theory interest in dispersion was greatly stimulated, and we find the names of Debye [15, 1915, 16, 1913], Sommerfeld [64, 1917], Ewald [20, 1916], Ladenburg [48, 1921], Bohr, Kramers, and Slater [9, 1924], and Kramers and Heisenberg [32, 1925].

useful work in the extension of dispersion measurements of hydrocarbons in the ultra-violet where the technique is so difficult, but more especially in the infra-red where with our present apparatus the technique is also relatively difficult. The resulting information will probably be of very considerable service as a means of identification.

3 Interpolation and Extrapolation of Refractive Indices for Different Wave-lengths. For practical purposes three formulae are used. As Vlugter, Waterman, and Van Westen [68, 1935] have recently pointed out, the approxi-

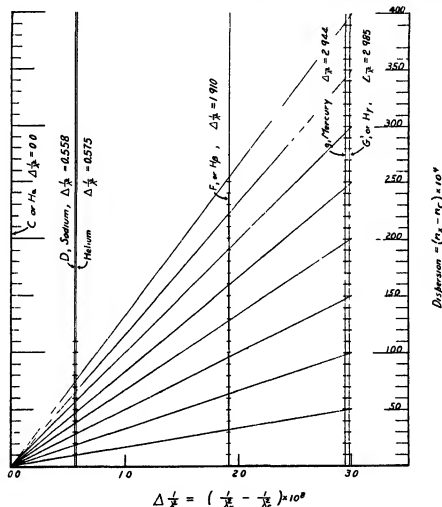

FIG. 1 Cauchy formula

With the development of wave mechanics came de Broglie [11, 1925], Schrodinger [61, 1926], Dirac [17, 1927], and Darwin [14, 1927].

With the further development of matrix mechanics, Heisenberg [32, 1925], Born, Heisenberg, and Jordan [10, 1926], and Dirac [17, 1927] studied dispersion. London [50, 1926] has discussed the relativistic aspects.

Summaries of the development of the various theories have been made by Jaffé [40, 1928], Wolf and Herzfeld [73, 1928], Lande [49, 1928], and Heitler [35, 1936]. Notwithstanding the very large amount of theoretical work that has been done on this subject, the lack of accurate data on the dispersion in the ultra-violet and infra-red regions has prevented a more extensive use of the theoretical formula. It is believed that there is a wide field for very

mate formula of Cauchy [12, 1836] $n = A + \frac{B}{\lambda^2} + \frac{C}{\lambda^4}$, &c., gives a linear relationship between n and $1/\lambda^2$. A convenient method of using this formula developed by the writers is to plot dispersion relative to the refractive index for the H_α line against $1/\lambda^2$. For hydrocarbons, the dispersion ($n_{H\alpha} - n_D$), which varies from about 0.005 to 0.035, a single master graph such as Fig. 1 may be used for all approximate interpolations or extrapolations.

Sellmeier's [62, 1871] equation may be used in the form

$$n^2 - 1 = \frac{a\lambda_0^2}{\lambda^2 - \lambda_0^2}$$

Here λ_0 = wave-length of the light used and λ_0 = wave-length of the characteristic absorption band. A recent

discussion of the use of this formula is given by Richtmeyer [59, 1928]

For more accurate interpolation in the visible spectra of colourless compounds, the empirical formula of Hartman [29, 1908, 35, 1936] is recommended. This is as follows

$$n - A - \frac{B}{(\lambda - C)^D}$$

where n is the refractive index for light of wave-length λ , and A , B , and C are constants. The value of D for optical glass is 1.2. For hydrocarbons it may be taken as 1. This formula appears to give more accurate results than the more complicated formulae developed later

Methods and Apparatus for Determining Refractive Index.

The modern apparatus has been developed to such a point that the refractive index of a liquid can probably be determined with greater rapidity, and to a higher degree of precision than can any other single physical constant. The optical considerations governing the determination of refractive index are discussed thoroughly by Houston [37, 1930].

There are two general methods of determination. In one, the angles of incidence and refraction of the substance contained in a hollow glass prism are measured on a spectrometer. This is known as the minimum deviation method. In the other method the angle of emergence of the totally reflected ray produced by illumination of the sample at grazing incidence is determined. This is known as the total reflection method.

1. Minimum Deviation Method. This is the classical method, and is still used for fundamental determinations. The prism containing the substance is adjusted so that the angle of incidence is equal to the angle of refraction. Under these conditions the entering rays suffer minimum change in direction of deviation, and the refractive index is then given by the formula

$$n = \frac{\sin \frac{1}{2}(D+P)}{\sin \frac{1}{2}P}$$

where D = angle of deviation, and
 P = prism angle

The temperature control is difficult, the adjustment and technique required are complicated, and the apparatus of the high degree of precision that is necessary is expensive. The angles should be capable of measurement to seconds of arc and the glass prism to contain the sample should have optically worked faces so that the cover-glasses which must be plane and parallel will adhere without the use of cement.

An error of 1 second of arc in measuring the prism angle or the deviation will cause an error of 0.000004 in n , so that the ordinary spectrometer reading to minutes of arc will give a precision of about 2 in the fourth place. With good apparatus and careful technique, a precision of 1 in the sixth place is readily attained, and 2 in the seventh place is possible.

A critical study of the factors affecting the accuracy of this method has been made by Tilton [66, 1935]. As will be noted from the data in Table II, a change of 1° C may change n by 0.0006. This means that for measurements that are accurate to the sixth decimal place, the temperature must be controlled within 0.001° C.

2. Total Reflection Methods. The instruments commonly

used in technical work depend upon the fact that when a layer of substance in contact with one face of a prism of higher refractive index than the substance is illuminated by light approximately parallel to the prism face, it meets the prism face at grazing incidence. The emergent beam is then bounded by a ray that actually grazes the prism surface and a ray that is totally reflected, thus setting up a dark border. The angle that this boundary ray makes with the emergent prism face is measured, and from this the refractive index may be calculated.

3. The Abbé Refractometer. One of the earliest and still more generally used types of apparatus utilizing this principle is that developed by Abbé [1, 1879]. A modern example of this type of apparatus is shown in Fig. 2, and a cross-section in elevation of an earlier model is shown in Fig. 3.

The instrument consists essentially of a prism, a scale (R) which is graduated in refractive indices, and a telescope (E) to observe the border-line of total reflection which is formed in the surface of the prism. The prism is of dense glass (such as flint) of high refractive index. The refractive index of the prism must exceed that of the sample to be measured.

The prism is enclosed in a metal case which contains a water-jacket to control the temperature. Hinged to this is a similar case containing an illuminating prism with ground surface. The two prisms are arranged so that when the case is closed the faces are approximately 0.15 mm apart. This space is filled with the liquid under examination. A mirror is provided to reflect light to the illuminating prism which has a ground face to scatter the light. Beams of light pass through the liquid and reach the second prism at all angles, including grazing incidence. The beam which meets the second prism at grazing incidence forms the border-line between the dark and light field.

As white light is used in this apparatus, the edge of the border-line formed by total reflection is tinted with prismatic colours due to the dispersion of the prism and sample. In order to eliminate the colour a device called a compensator (W) is used. This consists of two direct vision prisms (K) set for minimum deviation for the D line. They are arranged so that they can be rotated in opposite directions by means of bevel-gears. In this fashion the dispersion of the two prisms may be made to assume any value from 0 up to twice the dispersion given by a single prism. In this way, the dispersion caused by the flint prism is compensated by the variable dispersion of the compensator and the colour from the border-line is eliminated.

The eyepiece of the telescope contains a reticule with cross-hairs and the position of the prism is adjusted by means of the arm and slow-motion screw until the division of the field is at the intersection of the cross-hairs. The position of the scale is then read, usually by means of a low-powered microscope (M), in terms of refractive index for the D line.

The position of the compensator can be read on a scale and by the application of a suitable formula or by tables of the ($F-C$) dispersion of the sample can be obtained.

A discussion of the errors of the Abbé is given by Schonrock [60, 1922]. In the usual forms of the instrument the scale reads from 1.3 to 1.7 in refractive indices and is divided to three places of decimals, the fourth being estimated. The accuracy is about two units in the fourth place.

An instrument of higher precision has recently been put out by W. P. Valentine of Philadelphia. In this the scale is divided to four places and the fifth is estimated. Tests of this instrument by the National Bureau of Standards at

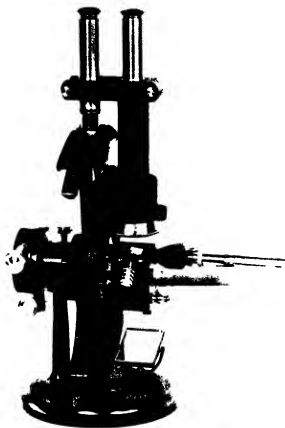

FIG. 2 Abbe refractometer

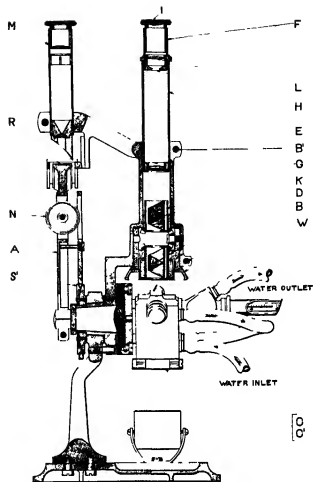

FIG. 3 Abbe refractometer cross section

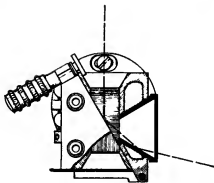

FIG. 4 Modified high-precision Abbe refractometer—prism assembly

Washington indicate that the accuracy of the instrument is limited by the precision with which the scale can be read, i. e. 2 to 3 units in the fifth place. To secure this degree of accuracy it is necessary that the temperature should be carefully controlled and the instrument be in accurate adjustment. The dispersion can be read to about 2 units in the fourth place.

With deeply coloured samples there may be insufficient light passing through the sample to permit accurate setting of the cross-hairs. To obviate this difficulty, a conical reflector is available on some instruments. This permits light to be reflected directly through the prism without passing through the sample. This is shown in Fig. 4. The reading is then made on a fine line that appears in the field at the boundary between the two portions that were formerly light and dark respectively. In Fig. 4 the bottom prism (through which light passes when measuring the n of transparent substances) has been partially cut away in order to show the water inlet and outlet.

4. The Dipping Refractometer. A modification of the Abbé instrument is known as the Dipping Refractometer. This finds considerable use where a large number of samples must be measured and where the range in refractive index is very narrow. The thin film of sample that is used in the usual type is replaced by dipping the whole prism into a small beaker containing the sample. The bottom of the beaker is of glass and illumination is furnished by a mirror placed below the beaker. The position of the border-line is read on a graduated scale in the eyepiece of the instrument and, by the application of appropriate factors, this reading may be converted into refractive index or any other scale as required.

The range of a single prism is rather narrow, being usually about 0.04, so that to cover any considerable range it is necessary to have a number of prisms. The Dipping refractometer is usually assumed to be of higher precision than the Abbé. This is true for the older Abbe instrument, but the more modern models are slightly more accurate than the Dipping refractometer.

5. Continuous Reading Refractometers. From an industrial point of view, it is interesting to note that refractometers have been developed recently which permit continuous observation of the refractive index of the liquid which flows through the instrument. One form of this type of apparatus is made by Zeiss of Jena. It depends upon the same optical principle as the Abbe crystal refractometer.

The apparatus in cross-section is shown in Fig. 5. Light from a lamp L (not shown) is reflected by the mirror R through the prism P at such an angle that some of the rays are totally reflected at the interface between the prism and the material in the vessel. The boundary-line between the light and dark portions of the field is observed in the eyepiece Ok which is provided with a graduated scale as in the Dipping refractometer.

Arrangements are made for cleaning the face of the prism in contact with the solution to be tested, and a mechanical device is used to compensate for the temperature of the solution.

The instrument is at present used principally in the manufacture of syrup and similar materials. Some type of continuous reading refractometer may ultimately have widespread use in the petroleum industry.

6. The Pulfrich Refractometer. This instrument depends on the same principle as the Abbé instrument. It is shown in Fig. 6. A beam of monochromatic light (from a vacuum-

tube which is supported in holder L) is directed horizontally by means of the condensing lens K through a thin layer of the substance that is held on the surface of the refracting

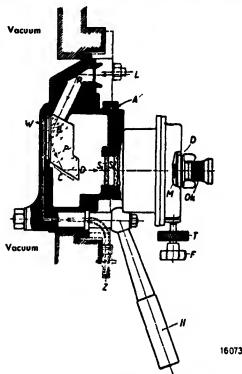

FIG. 5 A continuous reading refractometer

prism Pr by a glass cell. Suitable temperature-control arrangements are provided. The prism is water-jacketed and a cooling-jacket S , which is shown in detail in Fig. 7, is arranged to lower into the glass containing jacket until

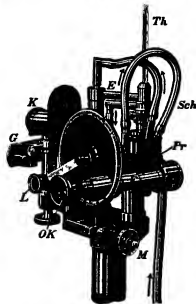

FIG. 6 The Pulfrich refractometer

it is in contact with the liquid under examination. The angular position of the emergent beam is read through a right-angle prism attached to the telescope F . The telescope

in turn is carried by the flat plate *T* which serves as the divided circle. The angle is read through a low-powered magnifier *L* with a vernier to 1 minute of arc

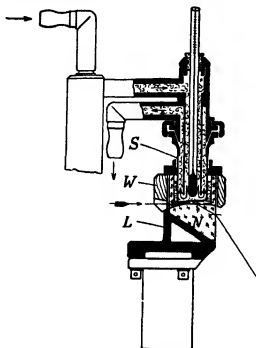

FIG 7 Cooling jacket for Pulfrich refractometer

The dispersion or the angular distance between the spectral lines can be read by means of the micrometer screw *M* to 6 seconds of arc, which is equivalent to 1 unit in the fifth place

The zero point of the scale is determined by means of a small reflecting prism placed in the eyepiece and arranged so that it covers a portion of the cross-hairs. When this is illuminated and the telescope is approximately in the zero position, a reflected image of the cross-hairs is seen in the field. When this is brought into coincidence with the cross-hairs it establishes the zero point of the scale

The small differential angles between the images of different spectral lines can be determined by means of a micrometer screw *G* that reads to 6 seconds of arc, thus permitting a higher degree of precision in the measurement of dispersion than in that of the index itself

In the Pulfrich instrument, the effective angle of the prism is 90° and the refractive index is equal to

$$n = \sqrt{(n_p^2 - \sin^2 r)}$$

when n_p = refractive index of the prism,
 r = angle of the refracted ray from the perpendicular to the refracting face

Tables are furnished by the makers to facilitate the calculations for different wave-lengths. Due to the use of a 90° prism as against a 60° prism in the Abbé type, the Pulfrich has an accuracy of about one point in the fourth place. This requires careful adjustment and temperature control

A critical study of the errors affecting the Pulfrich is made by J. Guild [27, 1917], and a discussion of the design is given by F. Simeon [63, 1917]. A general discussion of the instrument is given by Glazebrook [26, 1923]

7. **Refractive Index in the Ultra-violet.** Although little work has been done on the refractive index in the ultra-violet, partly because of the strong absorption in many compounds, it can be measured by the spectrometer method, using a fluorescent eyepiece and quartz optical parts. The refractive index can also be measured for lines in the ultra-violet by the use of a special form of quartz prism which carries the sample and is provided with a semi-circular block of quartz which forms a variable angle prism, the angle of which is capable of accurate measurement. The apparatus is placed before an ultra-violet spectrograph and the observations are made photographically. (See Henri [33, 1919] and Voellmy [69, 1927])

8. **Interference Refractometer.** Instruments utilizing the principles of interference have been developed for measuring very small differences in refractive index between two liquids. These instruments have a very high order of precision and accuracy, but the range is only about 0.008. Such apparatus finds considerable use, however, in certain physical chemical methods, principally in the examination of solutions. For a discussion of this type of instrument, see Kohlrausch [43, 1935, p. 393]. Some modifications of this apparatus have been recently made which somewhat extend this range

9. **Comparison of Refractometer Characteristics.** The fundamental requirements of precise refractometers are apparatus of accurate construction and known characteristics, precise angular measurement, and accurate thermometry. Speaking generally, the degree to which these fundamental requirements are met determines the usefulness of a particular instrument for a specific purpose

It is evident, however, that the different types of refractometers, although overlapping somewhat in their fields of usefulness, have rather definite characteristics that render them especially suitable for certain types of work

For the determination of fundamental constants, where accuracy in the sixth decimal place is important, the spectrometer or minimum deviation method is the only one capable of the required precision

For the usual technical work requiring the rapid determination of refractive index for a single wave-length (*D* line) the simplicity, accuracy, and rapidity of the modern Abbé type have resulted in its very general use

For work of the research type in which time is not so important and in which the accurate determination of refractive index for a wide and varied range of wave-lengths is required, the Pulfrich type is eminently suitable

10. **Calibration of Refractometers.** Refractometers may be calibrated by using pure compounds for which the refractive index is accurately known, or by the use of a glass plate of known refractive index. Water ($n_D^{20} = 1.33299$ relative to air 20° C, 760 mm., and 10% humidity) and benzene ($n_D^{20} = 1.50132$ relative to air under the same conditions) are examples of suitable liquids for such calibration. The Abbé refractometer has an adjusting screw so that the instrument can be adjusted to give the correct index reading

The above method is quite accurate if carefully used, but the glass-plate method is in general more rapid and reliable. In this method a glass plate is placed on the working face of the refractometer prism which has been moistened with monobromonaphthalene, a liquid which has a refractive index $n_D^{20} = 1.65820$, which is above that of the glass used

The test-plate is then illuminated through the polished end with a beam of light approximately at the grazing angle to the working face of the prism. The instrument should

then read the refractive index of the test-plate supplied by the manufacturer

11. **Correction of Refractometer for Temperature.** The effect of temperature on the refractive indices of hydrocarbons is discussed below. There is also an important temperature effect on the instrument itself because the refractive index of glass prisms changes with temperature as well as with wave-length just as does the refractive index of a hydrocarbon. For precise work, therefore, the observed reading with an Abbe or the calculated reading of a Pulfrich must be corrected for temperature if the instrument is used at a temperature different from that at which it was calibrated.

Pulfrich [57, 1892] made a careful study of the temperature effect on the refractive index of glass prisms. If δV is the change in the index of glass per degree Centigrade, a simplified correction to 20°C is given by $(N/n)\delta V(t-20^\circ)$. The value of δV should be given for each instrument by the makers. It is frequently given in the form of the tables for the different spectral lines for varying values of n in the form of $(N/n)\delta V$, so that it is only necessary to multiply the tabular correction by Δt . The correction is plus if $t > 20^\circ\text{C}$, and minus if $t < 20^\circ\text{C}$. The values of δV depend upon the particular glass used in the prism. When n_D for the prism is 1.75, the values are as follows:

Spectral line	C	D	F	G
δV	0.0000070	0.0000077	0.000105	0.000132
$(N/n)\delta V$	0.0000081	0.0000091	0.000124	0.000156

where $n = 1.5$

For a prism of $n_D = 1.65$, the values are about one-third of those given above. The prism in an Abbe frequently has a value of about 1.73 for N_D^{20} . The correction in this case is about 0.00007 per $^\circ\text{C}$.

In the petroleum industry refractometers are sometimes used alternately at widely different temperatures, for example, oils are determined at 20°C and waxes at 80°C . The temperature effect on the prism is about 0.0004. In cases where the value for δV is unknown, the correction may be made as follows:

(1) Select an oil or pure liquid for which the densities at 20°C and 80°C are known, (2) determine the refractive index at 20°C and calculate the refractive index at 80°C , using Eykman's equation or the approximate equation $n_D^{80} = n_D^{20} - 0.6(d_{80} - d_{20})$, (3) determine the refractive index at 80°C , (4) Determine n_D^{80} - Calculated n_D^{80} = Correction for n_D^{80} . This method of calibrating at 80°C will be sufficiently accurate for most purposes.

Standard Temperatures for Densities and Refractive Indices.

In the scientific literature a great deal of density data has been tabulated at 20°C (68°F), in fact, 20°C may be regarded as the internationally recognized standard temperature for recording, compiling, and comparing of physical property data on pure compounds. Unfortunately some scientific workers continue to report data at any temperature which may be convenient for them, be it 137°C or 151.68°C . The editors of scientific and technical journals should insist that densities be reported at a standard temperature such as 20°C , or better still, that densities at two or more temperatures be reported so that the data could be readily corrected to other temperatures as desired. Furthermore, it should always be clearly stated, as recommended by the A S T M, whether true densities or specific gravities are being reported and, in the latter case, the

temperature of the water used as the reference standard should be given [7, 1927]. In the case of precise data, it should be stated whether or not the densities have been corrected for the buoyancy of air.

Refractive index is so intimately related to density that it is always desirable to report both properties at the same temperature. Therefore, if densities are reported at 20°C , refractive indices should be reported at that temperature also. In hot, humid climates 20°C is sometimes below the dew-point of the atmosphere, causing moisture to deposit on the prism if it is exposed to the air. Difficulty from this condition can usually be avoided by applying the sample immediately after wiping the prism, but in some cases it may be necessary to make the experimental determination at 25° or 30°C and calculate to 20°C . Since 20°C is so generally used in scientific work as a standard temperature for densities, and since 20°C is also quite widely used for refractive index determinations, it is recommended that 20°C be used in reporting and comparing refractive index and density data.

Table IV provides coefficients for correcting densities and refractive indices of petroleum hydrocarbons for temperature in the range 10 - 30°C . Table VII provides corrections for petroleum hydrocarbons for converting from sp gr $60/60^\circ\text{F}$ to d_4^{20} .

In the petroleum industry 60°F (15.56°C) is a well-established reference temperature and is standard in the United States and England, but 20°C is used rather extensively in Europe, and 30°C is used by authors, such as Carpenter, who work in Burma and other hot regions. In this paper density in air at 20°C referred to water at 4°C has been tabulated for pure compounds and most of the petroleum fractions in order that comparison with pure compound data would be facilitated. In the case of crudes, and in certain other cases, all properly indicated, sp gr $60^\circ/60^\circ\text{F}$ has been tabulated.

Variation in Density and Refractive Index with Temperature.

It is well known that the volume of an oil increases with an increase in temperature and that, therefore, the density must decrease. Because hydrocarbon oils are sold on a volume basis, there are excellent tables for temperature-volume corrections not merely for petroleum hydrocarbons, but also for hydrocarbons from coal-tar and other sources. From these tables, some of which are reproduced in Appendix B, density changes may be calculated. Unfortunately, however, in the case of pure hydrocarbons, practically no generalizations have been attempted, although the larger handbooks contain temperature-correction formulae for a few individual hydrocarbons.

In the case of refractive index, the available information is even more meagre for pure hydrocarbons, and tables corresponding to those for temperature-volume corrections are non-existent. Finally, there has been practically no attempt to provide a simple correction between the change of density and index with change in temperature. The only published work that has been found is that of Herz [34, 1929], who compared 23 liquids, including a few hydrocarbons, and found the change in density to be from 2 to 96 times the change in index. It is true that the various equations for specific refraction provide correlations, but not in a form which is very convenient for use in correction of data.

The whole subject is of the utmost importance in attempting to make use of literature values, first because of

the failure of many authors to use a standard temperature for reporting densities, and secondly, because of the fact that even in cases in which a standard temperature is used for densities, refractive indices are frequently reported at different temperatures. For some unknown reason, it is a common practice to report densities at 20° C and indices at 25° C. Thus, temperature corrections become necessary not only to use individual data but to calculate refractivity, specific dispersion, and other expressions utilizing both density and refractive index.

In the following section the expressions vdC and vnC have been used to replace the more cumbersome $\Delta d/\Delta t^\circ C$ and $\Delta n/\Delta t^\circ C$, that is, the variation in density (or index) per degree Centigrade change in temperature. In the section on hydrocarbon mixtures, the corresponding vdF and vnF have been used to represent the variations per degree Fahrenheit. In all cases the sign of the variation is negative, that is, both density and index decrease with an increase in temperature.

Pure Hydrocarbons Values for Δd were calculated from all available literature data given for more than one temperature. The results were plotted and values obviously out of line were eliminated. It was found that for all series except the aromatics there was a linear relationship between density and change in density per degree change in temperature (vdC). The value Δd increases as d decreases. In general, this may be expressed by saying that $\Delta d/\Delta t$ increases as t approaches the boiling-point of the hydrocarbon. There is some evidence of small differences in Δd for different isomers, but the data do not permit any generalizations.

As stated above, published data for change in refractive index with temperature are extremely meagre in the case of pure hydrocarbons and practically non-existent in the case of hydrocarbon mixtures.

A study of what data were available resulted in a new generalization—strictly empirical—that the ratio vnC and vdC is practically constant and is approximately 0.6. This was checked by calculating the change in refractive index for the standard values for the change in density for hydrocarbon mixtures, using the refractivity equations of Eykman, and Lorentz-Lorenz, and the Waterman correction for the Lorentz-Lorenz formula (Waterman holds that the Lorentz-Lorenz formula increases 0.0005 for 20° C. This decreases the value for vnC by approximately 0.00005.) In these ways the following ratios were obtained:

Method	Ratio vnC/vdC
Lorentz-Lorenz formula	0.63-0.65
Waterman correction to Lorentz-Lorenz formula	0.57-0.59
Eykman formula	0.59-0.60
Empirical	0.56-0.63 (ave 0.59)

It seems well established, therefore, that the ratio vnC/vdC is so close to 0.6 that this value may be used in calculating change in refractive index with temperature from known values for change in density.

From the curves, the Δd values corresponding to even values for d were read off and are summarized in Table II. It will be observed that Δd is higher for saturated cyclics than for paraffins and that the introduction of one double bond increases Δd significantly.

In so far as data are available, the values for diolefines and unsaturated cyclics with two double bonds fall surprisingly close to the corresponding curves for mono-olefines and unsaturated cyclics. There are insufficient data

to permit the drawing of a safe generalization. However, if no value for Δd is known for a given diolefin, it is believed that the corresponding mono-olefine may be used with reasonable assurance.

TABLE II
Change in Density of Hydrocarbons $\times 10^6$ per Degree Centigrade for the Range 10-30° C

d 20°/10°	Paraffins, vdC	Olefin ¹ , vdC	Saturated cyclics, vdC	Unsaturated cyclics, vdC	Petro- leum, ² vdC
	0.60	105			
0.65	94	103			95
0.70	81	92	101 _{1/2}		87
0.75	72	81 _{1/2}	91	99	80
0.80	61	71	80 _{1/2}	88 _{1/2}	72
0.85	50	60	70	78 _{1/2}	69 _{1/2}
0.90		49 _{1/2}	60	68	67
0.95			49 _{1/2}	57 _{1/2}	64
1.00				47 _{1/2}	61

¹ Based on abridged petroleum tables [4, 1916]

The aromatics constitute a special class of compounds in so far as change in density and index with temperature is concerned.

The values for the aromatics are summarized in Table III. These data are largely taken from the work of Auwers. It is interesting to note that the ratio vnC/vdC is quite constant for the aromatics also. The average value is 0.59.

TABLE III

Change in Density and Refractive Index (D line) of Aromatics with Change in Temperature for the Range 10-30° C

Aromatic	($\times 10^6$)		vnC/vdC
	vdC	vnC	
Benzene	104	61	0.59
Toluene	93	56	0.60
Ethyl benzene	88	51	0.61
Xylenes	83	47	0.57
Trimethyl benzene	78	45	0.58
Propyl benzene	81	47	0.58
Methyl ethyl benzenes	80	46	0.59
Diethyl benzenes	78	45	0.58
Methyl propyl benzenes	79	46	0.58
Butyl benzenes	78	45	0.58
Amyl benzenes	75	45	0.60
Trethyl benzenes	75	45	0.60
Trimethyl diethyl benzenes	79	45	0.57
Tetra-ethyl benzenes	75	45	0.60

Petroleum Hydrocarbon Mixtures The data for A P I groups 0-VII, wax, and liquefied gases are summarized in Table IV. The changes in both density and index are given for changes of 1° F and 1° C. As stated above, the Δn values are calculated from the Eykman equation. The values for vdC given in Table II were obtained from column e . Referring to Table II it will be noted that groups V, VI, and VII are largely paraffinic hydrocarbons. Groups IV to II contain increasing quantities of cyclic hydrocarbons. The values for groups 0 and I lie well above the values for saturated cyclics, confirming the complex character of petroleum fractions having densities of 0.9 or greater.

Hydrocarbon Mixtures from Sources other than Petroleum (Tar Products). In general, tar products are largely—but not entirely—aromatic in nature. Accordingly, the rate of change of specific gravity with temperature is more irregular for different mixtures than has been observed for non-aromatic petroleum products. Although it is not pos-

DENSITY AND REFRACTIVE INDEX OF HYDROCARBONS AND PETROLEUM PRODUCTS 1147

able to correlate the rate of change in specific gravity with the actual specific gravity, the same general trend of increase in νdC with decrease in ν is observed. In Table V are given some representative values for νdC for a number of classes of tar products together with the observed specific gravity at 25°/25° C and 60°/60° F. The former temperatures are standard for tar products in commerce, and the latter have been used in this paper for hydrocarbon mixtures.

theoretical aspects of the subject are complex and beyond the scope of this work, and theoretical treatment is hampered by lack of accurate data for refractive indices at high temperatures. The work of Eykman [22, 1896] is invaluable since he does provide accurate data for a few hydrocarbons at a variety of temperatures and with a variety of wavelengths.

Since refractive index is connected with the frequency of vibration of electrons, it is probable that change of tem-

TABLE IV
Coefficients to be used in Correcting Densities and Refractive Indices of Petroleum Products

Group*	° API 60° F	Density 20° C g per ml		Decrease in density for each degree increase in temperature in range 10-30° C multiplied by 10 ⁴		Refractive index n _D ²⁰	Decrease in refractive index for each degree increase in temperature in range 10-30° C multiplied by 10 ⁴		Ratio n/n _D
		Representative	Range	νdC	νdF		Representative	νnC	
I	6	1.0298	0.962 and up	61	34	1.566	36	21	0.59
	22	0.918	0.847-0.961	66	37	1.509	39	21 _{1/2}	0.59
Wax†	43	0.807†		(67)†	(37)†	1.451	(40)†	(22)	0.60
	II	44	0.802	0.773-0.846	72	40	1.468	43	0.60
III	58	0.742	0.720-0.772	82	45	1.417	49	27	0.60
IV	72	0.691	0.668-0.719	88	49	1.390	53	29	0.60
V	86	0.646	0.637-0.667	94 _{1/2}	52 _{1/2}	1.367	57	31 _{1/2}	0.60 _{1/2}
VI	91	0.631	0.623-0.646	97	54	1.360	58	32 _{1/2}	0.60 _{1/2}
VII	97	0.614	0.606-0.622	100 _{1/2}	56	1.352	61	34	0.60 _{1/2}
Butanest	111	0.578		12 _{1/2}	6 _{1/2}				
Propanest	147	0.501		16 _{1/2}	8 _{1/2}				

* For groups 0 to VII see [4, 1916] [13, 1933], [41, 1930]

† Data on wax are for 120-32° F melting point paraffin. The density and refractive index values at 20° C are the hypothetical values which would exist if the wax did not crystallize on cooling. The actual density of this wax in the crystalline condition at 20° C is approximately 0.907. The temperature coefficients given are for the range 20-80° C.

‡ Data on liquefied gases under pressure

§ This representative density for group 0 is based on 1936 revision of A S T M designation D 206

|| $\nu dC = \Delta d / \Delta T \times 10^4$; $\nu dF = \Delta d / \Delta T \times 10^4$; $\nu nC = \Delta n / \Delta T \times 10^4$; $\nu nF = \Delta n / \Delta T \times 10^4$, for example, an oil having a density of 0.8020 at 20° C, will have a density of 0.8013 at 21° C.

Standard volume and specific gravity correction tables for coal-tar products art. published by the A S T M [6, 1933]

TABLE V
Change in Specific Gravity of Tar Products with
Temperature (Representative Values)

Crude tars	Sp gr		$\nu dC \times 10^4$	$\nu nF \times 10^4$
	25° C (25° C)	60° F (60° F)		
Horizontal oval-tar	1.242	1.243	65-8	36-8
Vertical coal tar	1.112	1.113	70-2	39-40
Coals-oven tar	1.184	1.185	68-70	38-9
Low-temperature tar	1.117	1.118	73-5	41-2
Light water gas tar	1.093	1.094	66-9	37-8
Heavy water gas tar	1.185	1.186	63-5	35-6
Tar distillates				
Light oil	0.898	0.901	97-9	54-5
Naphthalene oil	0.990	0.992	82-4	46-7
And oil	0.990	0.990	80-2	44-6
Light dead oil	1.011	1.013	77-9	43-4
Heavy dead oil	1.020	1.022	75-7	42-3
Creosote oil	1.060	1.062	74-6	41-2
Refined products				
Benzol (benzene)	0.8812	0.884	102-4	57-8
Toluol (toluene)	0.866	0.869	93-5	52-3
Xylol (xylene)	0.862	0.865	83-5	46-7
Solvent naphtha	0.864	0.867	85-7	47-8
Heavy naphtha	0.871	0.873	82-4	46-7

Theoretical Aspects of the Effect of Temperature on Refractive Index. For those interested in the history of the effect of temperature on refractive index the work of Gladstone and Dale [25, 1858], Puffrich [57, 1892], Fockels [56, 1902], Lorentz [51, 1909], Debye [16, 1913], and Buchowicz and Merwin [8, 1921] should be consulted. The

perature has two effects, (1) to change the number of absorbing electrons per milliliter by changing the density, and (2) to change the frequency of vibration of the absorbing electrons. This is discussed in a recent publication [47, 1936] and will be discussed more fully in a subsequent article.

Correction for the Density of Water. An accurate determination of either $sp\ gr\ t'/t$ or d'_t/d_t cannot be made directly unless correction is made for the change in volume of the glass as described under 'Methods of Determining Density or Specific Gravity'. Rather than risk any uncertainty in applying this correction, it is preferable to calibrate the pycnometer or other device at the temperature at which the sample is to be measured. In other words, the sample and water are measured at the same temperature. If the sample is to be referred to water at a different temperature, a correction for the difference in density of the water at the temperatures must be applied. Thus, where W' and W are the weights of an equal volume of sample and water at t' and D' and D are the densities of water at t' and t respectively,

$$sp\ gr\ t'/t = \frac{W'}{W} \times \frac{D}{D'}$$

and
$$d'_t/d_t = \frac{W'}{W} \times \frac{D'}{D}$$

The densities of water at temperatures from 0 to 30° C are given in Appendix D. From this table (or larger tables) the correction for the density of water may be readily made.

Example 1. The ratio of the weights of equal volumes of a sample and water at 25° C (or the specific gravity of a sample at 25°/25° C) is 0.8545. The specific gravity 25°/15 56° C = 0.8545 × 0.9970770 = 0.8528

This type of calculation is sometimes required for conversion of sp gr t'/t to sp gr $t/15.56^\circ\text{C}$, so that the specific gravity will be the same as would determined at $t^\circ\text{C}$ with an hydrometer calibrated to read relative to water at 15.56°C (60°F)

A more common type of calculation is to convert either sp gr t'/t to d_4^t , or sp gr t'/t to $d_4^{15.56}$. Table VI has been prepared as an aid in the correction of specific gravities at various temperatures to densities (i.e. specific gravities relative to water at 4°C) Table VI may be used for the approximate solution of example 1 by subtracting the difference in factors, i.e. $0.8545 - (0.0025 - 0.0008) = 0.8528$

TABLE VI
Conversion of Specific Gravity t'/t to d_4^t

Temp of water t		Sp gr t'/t	To convert sp gr t'/t to d_4^t subtract
$^\circ\text{C}$	$^\circ\text{F}$		
0	32	all	0.0001
10	50	> 0.91	0.0003
		< 0.91	0.0002
15.56	60	0.995	0.0010
"	"	0.99-0.995	0.0009
"	"	0.99-0.99	0.0008
"	"	0.98-0.99	0.0007
"	"	0.98-0.98	0.0006
20	68	0.99	0.0018
"	"	0.94-0.99	0.0017
"	"	0.89-0.94	0.0016
"	"	0.83-0.89	0.0015
"	"	0.77-0.83	0.0014
"	"	0.71-0.77	0.0013
"	"	0.66-0.71	0.0012
"	"	0.60-0.66	0.0011
"	"	0.54-0.60	0.0010
25	77	0.97	0.0029
"	"	0.94-0.97	0.0028
"	"	0.91-0.94	0.0027
"	"	0.87-0.91	0.0026
"	"	0.84-0.87	0.0025
"	"	0.80-0.84	0.0024
"	"	0.76-0.80	0.0023
"	"	0.73-0.76	0.0022
"	"	0.69-0.73	0.0021
"	"	0.66-0.69	0.0020
"	"	0.63-0.66	0.0019
"	"	0.60-0.63	0.0018
"	"	0.57-0.60	0.0017
30	86	0.97	0.0042

Example 2 The sp gr $20^\circ/20^\circ\text{C}$ of a sample is 0.7608 To convert to $20^\circ/4^\circ\text{C}$ subtract 0.0013, which gives 0.7595

When both the temperature of the hydrocarbon and the water are to be changed, the change in density of the hydro-

carbon as well as of water must be taken into account. The necessary values for the change in density of pure hydrocarbons are given in Table II. Similar values for petroleum hydrocarbon mixtures are given in Table IV, and on the basis of this data Table VII has been prepared for the special case of converting sp gr $60^\circ/60^\circ\text{F}$ to d_4^{60} for petroleum products

Example 3 The sp gr $25^\circ/25^\circ\text{C}$ of a pure paraffin hydrocarbon in the liquid state is 0.7261 To convert to d_4^{60} subtract 0.0021, which gives 0.7240 To correct from sp gr $25^\circ/4^\circ\text{C}$ to d_4^{60} add 5×0.00077 (see Table II) or 0.0039 The density at 20°C relative to water at 4°C is, therefore, 0.7279 g per ml

Example 4 The sp gr $15.56^\circ/15.56^\circ\text{C}$ of a kerosene is 0.8055 To correct to d_4^{60} subtract 0.0008, which gives 0.8047 To correct from d_4^{60} to d_4^{20} , subtract $4.5(4.44) \times 0.00072$ or 0.0032, which gives 0.8015

Example 5 A petroleum fraction has an API gravity of 46, and, therefore, as sp gr $60^\circ/60^\circ\text{F}$ of 0.7972 From Table VII the correction is 0.0040, and the density 20°C relative to water at 4°C is 0.7932

TABLE VII
Conversion of Specific Gravity $60^\circ/60^\circ\text{F}$ to d_4^{60} or d_4^{20} for Petroleum Hydrocarbon Mixtures

Specific gravity $60^\circ/60^\circ\text{F}$	Correction to be subtracted from specific gravity $60^\circ/60^\circ\text{F}$	
	To convert to d_4^{60}	To convert to d_4^{20}
1.10	0.00105	0.00350
1.00	0.00095	0.00370
0.90	0.00086	0.00380
0.85	0.00081	0.00390
0.80	0.00076	0.00400
0.78	0.00074	0.00410
0.76	0.00073	0.00420
0.74	0.00070	0.00430
0.72	0.00069	0.00445
0.70	0.00067	0.00455
0.68	0.00065	0.00470
0.66	0.00063	0.00480
0.64	0.00061	0.00490
0.62	0.00059	0.00500
0.60*	0.00057	0.00510
0.55*	0.00053	0.00540
0.50*	0.00048	0.00570
0.60†	0.00057	0.00550
0.55†	0.00053	0.00570
0.50†	0.00048	0.00780

* Obtained by extrapolation of data for petroleum products having specific gravities $60^\circ/60^\circ\text{F}$ between 0.80 and 0.60 at atmospheric pressure

† Obtained by drawing a straight-line curve through data for propane and butane in liquefied condition under pressure Use for liquefied gases only

REFERENCES

1. AASS, E. *Carl's Repertorium für Experimental Physik*, 15, 643 (1879).
2. A S T M Serial Designation D 70-27
3. — Serial Designation D 71-27
4. — Serial Designation D 206-93
5. — Serial Designation D 287-33
6. — Serial Designation D 347-33
7. — Serial Designation E 12-27
8. BRCHOWSKY, F. R., and MERWIN, H. E. *J Optical Soc Amer*, 5, 441 (1921)
9. BOHR, N., KRAMBA, H. H., and SLATER, J. C. *Z Phys*, 24, 69 (1924).
10. BORN, M., HEISENBERG, W., and JORDAN, P. *Z Phys*, 35, 357 (1926)
11. BROGLIE, L. DE. *Ann I Phys* (10), 3, 22 (1925)
12. CAUCHY, A. L. *Mémoires sur la Dispersion de la lumière*, p. 62 (A. G. Calus, Prague, 1836)
13. CRAIGOR, C. S. *Miscellaneous Public U.S. Bur of Stds no 97 1-48* (Govt Print Office, Washington, D. C., 1933)
14. DALRYMPLE, C. G. *Proc Roy Soc*, 116, 227 (1927)
15. DERBY, F. *München Ber* 1 (1915)
16. — *Ver d Deut Phys Ges*, 15, 771 (1913)
17. DERAC, F. A. M. *Proc Roy Soc*, A, 114, 243 (1927)
18. — *Proc Roy Soc*, A, 117, 610 (1928)

DENSITY AND REFRACTIVE INDEX OF HYDROCARBONS AND PETROLEUM PRODUCTS 1149

- 19 DRUDE, P *Wied Ann* 48, 536 (1893)
 20 EWALD, P P *Ann Phys* 49, 1-117 (1916)
 21 EYKMAN, J F *Recherches Refractometriques* (Naturkundige Verhandelingen-Hollandische Maatschappij Wetenschappen, Haarlem, 1919)
 22 — *Recueil des travaux chimiques des Pays-Bas*, 15, 56 (1895)
 23 FARKAS, A *Light and Heavy Hydrogen* (Cambridge University Press, England, 1935)
 24 FERRIS, S W, and ALEXANDER, J A Unpublished work
 25 GLADSTONE, F, and DALE, J *Phil Trans* 148, 887 (1858), 153, 317 (1864)
 26 GLAZEBROOK, R *Dictionary of Physics*, 4, 772 et seq (Macmillan Publishing Co., New York, 1923)
 27 GUILD, J *Proc Phys Soc* 30 B, 157 (1917)
 28 HARTLEY, H, and BARRETT, W H *J C S* 99, 1072 (1911)
 29 HARTMANN, J *Publ Astra Obs Patsum*, 12, Appendix no 42, 1 (1908)
 30 HELMHOLTZ, V H *Pogg Ann* 154, 582 (1875)
 31 — *Wied Ann* 48, 389 and 723 (1893)
 32 HEISENBERG, W *Z Phys* 33, 879 (1925)
 33 HENRI, V *Études de Photochimie Gauthier-Villars* (1919)
 34 HERTZ, W *Z Allgem Chem* 180, 159 (1929)
 35 HEYLER, W *Quantum Theory of Radiation* (Clarendon Press, Oxford, 1936)
 36 HOFFMAN, FR *Z Phys* 30, 238 (1929)
 37 HOUSOUN, R A *Treatise on Light* (Longmans, Green & Co., N Y, 1930)
 38 *International Critical Tables*, 7, 3 (McGraw-Hill Book Co., New York, 1930)
 39 I P T Serial Designation G 1 (1935)
 40 JAFFÉ, G *Handbuch Exp Phys* 19, 1 (Akademische Verlagsges m b H Leipzig, 1928)
 41 JESSUP, R S *US Bur Stand J Res* 5, 985 (1930)
 42 KETTLER, E *Pogg Ann* 140, 177 (1870)
 43 KOHLRAUSCH, F *Praktische Physik* (B G Teubner, Leipzig, 1935)
 44 KOLACZEK, F *Wied Ann* 32, 224-428 (1887)
 45 KRAMERS, H A, and HEISENBERG, W *Z Phys* 31, 681 (1925)
 46 KUNDT, A *Wied Ann* 34, 469 (1888)
 47 KURTZ, S S, JR, and WARD, A L *J Franklin Inst* 221 (1936)
 48 LADENBURG, R *Z Phys* 4, 451 (1921)
 49 LANDÉ, A *Handbuch d Physik*, 20, 406 (Geiger, H, and Scheel, K., Julius Springer, Berlin, 1928)
 50 LONDON, F *Z Phys* 39, 322 (1926)
 51 LORENZ, H A *Theory of Electrons* (Teubner, Leipzig, 1909)
 52 — *Verh A K Akad Amsterdam*, 18 (1879)
 53 LORENZ, L *Viedensk Selok Skoffer*, 5, 8205 (1869), *Wied Ann* 11, 70 (1880)
 54 Natural Gas Assoc of America, Tentative Methods (1933)
 55 OTTAWALD, W, LUTHFFER, R, DRUCKER, C *Physiko-Chemische Messungen*, 4th ed (Akademische Verlagsgesellschaft m b H Leipzig, 1925)
 56 POCKELS, F *Ann d Physik*, 745 (1902)
 57 PULFRICH, C *Wied Ann* 45, 609 (1892)
 58 RICHARDS, T W, and CHADWELL, H M *J A C S* 47, 2283 (1925)
 59 RICHTMEYER, F K *Introduction to Modern Physics* (McGraw-Hill Book Co., New York, 1928)
 60 SCHONROCK O *Z d ver Deut Zuck Ind* 64, tech part, 10 (1914), 71, tech part, 267 (1921), *Wiss Ab d Phys-Tech Reichs A* 5, 267 (1922)
 61 SCHRODINGER E *Ann d Physik* 79, 361-489, 734 (1926)
 62 SILLIMMER, W *Pogg Ann* 143, 272 (1871)
 63 SIMON, F *Proc Phys Soc* 30, 190 (1917)
 64 SOMMERFELD, A *Z Phys* 8, 841 (1907)
 65 TAGLIAPIRE Copyrighted circular published in 1914 (Permission to publish received)
 66 TILTON, L W *US Bur Stand J Res* 14, 393 (1935)
 67 *US Bur Slids Technical Paper* 77 (1916)
 68 VILGUTER, J C WATERMAN, H I, VAN WEIEN, H A *J I P T* 21, 661 701 (1935)
 69 VOELLMY H *Z Phys Chem* 127, 305 (1927)
 70 VOIGT, W *Wied Ann* 67, 345 (1899)
 71 WADE, J, and MERRIMAN, R W *J C S* 101, 2429 (1912)
 72 WARD, A L, and FULWEILER, W H *Ind Eng Chem, Anal Ed* 6, 396 (1934)
 73 WOLF, K L, and HERZFELD, K F *Handbuch der Physik*, 20, 480 (Geiger, H, and Scheele, K., Julius Springer, Berlin, 1928)
 74 WOOD, R W *Physical Optics*, 375 (Macmillan Publishing Co., New York, 1914)

APPENDIX A

TABLE SHOWING SPECIFIC GRAVITIES, POUNDS PER U.S. GALLON,
AND U.S. GALLONS PER POUND AT 60° F. CORRESPONDING TO
DEGREES API.

A.S.T.M. Serial Designation D. 287-36

The following table is primarily an abridgment of Table 5 of the 'National Standard Petroleum Oil Tables' as published in the U S Bureau of Standards Circular No 154, which contains similar data for each 0.1° API

from 10 to 100° API, inclusive. The data for gravities from 0 to 9° API, inclusive, have been added in order to extend the use of the API gravity scale to petroleum oils having a specific gravity slightly greater than unity

Table Showing Specific Gravities, Pounds per U S Gallon, and U S Gallons per Pound at 60° F.,
Corresponding to Degrees API

*API	Specific gravity at 60°/60° F.	Lb per gal at 60° F.	Gal per lb at 60° F.	*API	Specific gravity at 60°/60° F.	Lb per gal at 60° F.	Gal per lb at 60° F.	*API	Specific gravity at 60°/60° F.	Lb per gal at 60° F.	Gal per lb at 60° F.	*API	Specific gravity at 60°/60° F.	Lb per gal at 60° F.	Gal per lb at 60° F.
0	0.7660	8.962	0.1116	25	0.9042	7.520	0.1328	50	0.7796	6.490	0.1541	75	0.8852	5.703	0.1753
1	0.6799	8.895	0.1124	26	0.8984	7.481	0.1337	51	0.7753	6.455	0.1549	76	0.8819	5.676	0.1762
2	0.6599	8.828	0.1133	27	0.8927	7.434	0.1345	52	0.7711	6.420	0.1558	77	0.8787	5.649	0.1770
3	0.6520	8.762	0.1141	28	0.8871	7.387	0.1354	53	0.7669	6.385	0.1566	78	0.8754	5.622	0.1779
4	0.6443	8.696	0.1150	29	0.8816	7.341	0.1362	54	0.7628	6.350	0.1575	79	0.8722	5.595	0.1787
5	0.6366	8.634	0.1158	30	0.8762	7.296	0.1371	55	0.7587	6.316	0.1583	80	0.8690	5.568	0.1796
6	0.6291	8.571	0.1167	31	0.8708	7.251	0.1379	56	0.7547	6.283	0.1592	81	0.8659	5.542	0.1804
7	0.6217	8.509	0.1175	32	0.8654	7.206	0.1388	57	0.7507	6.249	0.1600	82	0.8628	5.516	0.1813
8	0.6143	8.448	0.1184	33	0.8602	7.163	0.1396	58	0.7467	6.216	0.1609	83	0.8597	5.491	0.1821
9	0.6071	8.388	0.1192	34	0.8550	7.119	0.1405	59	0.7428	6.184	0.1617	84	0.8566	5.465	0.1830
10	0.6000	8.328	0.1201	35	0.8498	7.076	0.1413	60	0.7389	6.151	0.1626	85	0.8536	5.440	0.1838
11	0.5920	8.270	0.1209	36	0.8448	7.034	0.1422	61	0.7351	6.119	0.1634	86	0.8506	5.415	0.1847
12	0.5861	8.212	0.1218	37	0.8398	6.993	0.1430	62	0.7313	6.087	0.1643	87	0.8476	5.390	0.1855
13	0.5792	8.155	0.1226	38	0.8348	6.951	0.1439	63	0.7275	6.055	0.1651	88	0.8446	5.365	0.1864
14	0.5725	8.099	0.1235	39	0.8299	6.910	0.1447	64	0.7238	6.023	0.1660	89	0.8417	5.341	0.1872
15	0.5659	8.044	0.1241	40	0.8251	6.870	0.1456	65	0.7201	5.994	0.1668	90	0.8388	5.316	0.1881
16	0.5593	7.989	0.1252	41	0.8203	6.830	0.1464	66	0.7165	5.964	0.1677	91	0.8360	5.291	0.1889
17	0.5529	7.935	0.1260	42	0.8155	6.790	0.1473	67	0.7128	5.934	0.1685	92	0.8331	5.269	0.1898
18	0.5465	7.882	0.1269	43	0.8109	6.752	0.1481	68	0.7093	5.904	0.1694	93	0.8303	5.246	0.1906
19	0.5402	7.830	0.1277	44	0.8063	6.713	0.1490	69	0.7057	5.874	0.1702	94	0.8275	5.222	0.1915
20	0.5340	7.778	0.1286	45	0.8017	6.675	0.1498	70	0.7022	5.845	0.1711	95	0.8247	5.199	0.1924
21	0.5279	7.727	0.1294	46	0.7972	6.637	0.1507	71	0.6988	5.817	0.1719	96	0.8220	5.176	0.1932
22	0.5218	7.676	0.1303	47	0.7927	6.600	0.1515	72	0.6953	5.788	0.1728	97	0.8193	5.154	0.1940
23	0.5159	7.627	0.1311	48	0.7883	6.563	0.1524	73	0.6919	5.759	0.1736	98	0.8166	5.131	0.1949
24	0.5100	7.578	0.1320	49	0.7839	6.526	0.1532	74	0.6886	5.731	0.1745	99	0.8139	5.109	0.1957
												100	0.8112	5.086	0.1966

* The data in this column are based upon apparent weights in air, the weight of 1 gallon of water at 60° F in air being assumed to be 8.32828 lb. Consequently, a correction for the buoyancy of air is required in computing these figures from the specific gravities in the second column.

APPENDIX B

STANDARD ABRIDGED VOLUME CORRECTION TABLE FOR PETROLEUM OILS¹

A.S.T.M. Serial Designation D. 206-36

This table is issued under the fixed designation D 206, the final number indicates the year of original adoption as standard or, in case of revision, the year of last revision

ADOPTED, 1925, REVISED, 1934, 1936

This table has been approved as
AMERICAN STANDARD
by the American Standards Association

This abridged table has been prepared by the U.S. Bureau of Standards to meet a demand from the oil industry for a short and convenient table for reducing oil volumes to the basis of 60° F., when extreme accuracy is not required. It is not intended to replace the Bureau of Standards Circular No. 154, but rather to supplement it, and especially to replace the various abridged tables heretofore employed in the oil industry².

The groups, coefficients of expansion, gravity (degrees API), and gravity ranges for the several subdivisions of the present abridged tables are shown in the opposite column.

The following tables show the volume occupied at 60° F. by a quantity of oil occupying unit volume at the indicated temperatures.

For purposes of brevity the columns showing observed temperatures in degrees Fahrenheit carry the heading *t*. The columns of multipliers which are actually

$$\left(\frac{\text{volume at } 60^\circ \text{ F.}}{\text{volume at } t} \right)$$

carry the heading *M*.

Example The values given in the table are in the form of multipliers, that is, the volume of oil at the indicated temperature and degrees API for each group, multiplied by the corresponding factor in the table, equals the volume at 60° F. For example, if the degrees API of an oil at 60° F. equals 58 (Group 3) and the volume at 88° F. equals 8,000 gal., then the volume at 60° F. equals $8,000 \times 0.9830$ or 7,864 gal.

Coefficients of Expansion, Gravity (Degrees API)

Group number	Coefficient of expansion per ° F. at 60° F.	Gravity, degrees API	Gravity range of group (degrees API at 60° F.)
0	0.00035	6	Up to 14.9
1	0.00040	22	15.0 to 34.9
2	0.00050	44	35.0 to 50.9
3	0.00060	58	51.0 to 61.9
4	0.00070	72	64.0 to 78.9
5	0.00080	86	79.0 to 88.9
6	0.00085	91	89.0 to 93.9
7	0.00090	97	94.0 to 100.0

All motor-fuel blends of gasoline and benzol shall be considered as falling in Group 3. In cases of uncertainty regarding the presence of benzol, a product having a gravity heavier (numerically less) than 51° API, and a 50% recovery point less than 293° F. (145° C.) shall be considered as falling in Group 3.

The multipliers in the Group 0 table in the 1934 standard were taken from the National Bureau of Standards Miscellaneous Publication No. 97. With the revision of Circular No. 154 (to be published as Circular No. 410) to include data on oils from 0 to 10° API, it has seemed desirable to employ the procedure followed in the other groups and choose the column of multipliers from the unabridged table which has a base coefficient of expansion nearest 0.00035, which in the case of Group 0 is the column corresponding to a gravity of 6° API.

¹ Under the standardization procedure of the Society, this table is under the jurisdiction of the A.S.T.M. Committee D-2 on Petroleum and Lubricants.

² This table comprises a revision of the Standard Abridged Volume Correction Table for Petroleum Oils (D 206-25), 1933 Book of A.S.T.M. Standards, Part II, p. 846, which table it supersedes.

³ This abridged table differs from that published in 1934 in three respects. The multipliers for Group 0 have been revised slightly, Group 1 has been extended from 249 to 499° F., and Groups 4, 5, and 6 have been extended from 99 to 124° F.

GROUP 0*

Legend t = observed temperature in degrees Fahrenheit, M = multiplier for reducing oil volumes to the basis of 60° F

t	M	t	M	t	M	t	M	t	M	t	M	t	M	t	M	t	M		
1	0.0211	50	1.0035	100	0.9862	150	0.9691	200	0.9523	250	0.9360	300	0.9201	350	0.9045	400	0.8893	450	0.8744
2	1.0208	51	1.0032	101	0.9858	151	0.9687	201	0.9520	251	0.9357	301	0.9198	351	0.9042	401	0.8890	451	0.8741
1	1.0204	52	1.0028	102	0.9855	152	0.9684	202	0.9517	252	0.9354	302	0.9195	352	0.9039	402	0.8887	452	0.8738
3	1.0201	53	1.0025	103	0.9852	153	0.9680	203	0.9513	253	0.9351	303	0.9191	353	0.9036	403	0.8884	453	0.8735
4	1.0197	54	1.0021	104	0.9848	154	0.9677	204	0.9510	254	0.9347	304	0.9188	354	0.9033	404	0.8881	454	0.8732
5	1.0194	55	1.0017	105	0.9844	155	0.9674	205	0.9507	255	0.9344	305	0.9185	355	0.9030	405	0.8878	455	0.8729
6	1.0190	56	1.0014	106	0.9841	156	0.9670	206	0.9504	256	0.9341	306	0.9182	356	0.9027	406	0.8875	456	0.8726
7	1.0186	57	1.0010	107	0.9837	157	0.9667	207	0.9500	257	0.9338	307	0.9179	357	0.9024	407	0.8872	457	0.8723
8	1.0183	58	1.0007	108	0.9834	158	0.9664	208	0.9497	258	0.9335	308	0.9176	358	0.9021	408	0.8869	458	0.8720
9	1.0179	59	1.0003	109	0.9831	159	0.9660	209	0.9494	259	0.9331	309	0.9173	359	0.9017	409	0.8866	459	0.8717
10	1.0176	60	1.0000	110	0.9827	160	0.9657	210	0.9490	260	0.9328	310	0.9169	360	0.9014	410	0.8863	460	0.8714
11	1.0172	61	0.9997	111	0.9823	161	0.9654	211	0.9487	261	0.9325	311	0.9166	361	0.9011	411	0.8860	461	0.8711
12	1.0168	62	0.9993	112	0.9820	162	0.9650	212	0.9484	262	0.9322	312	0.9163	362	0.9008	412	0.8857	462	0.8709
13	1.0165	63	0.9990	113	0.9816	163	0.9647	213	0.9481	263	0.9319	313	0.9160	363	0.9005	413	0.8854	463	0.8706
14	1.0161	64	0.9986	114	0.9813	164	0.9643	214	0.9477	264	0.9315	314	0.9157	364	0.9002	414	0.8851	464	0.8703
15	1.0158	65	0.9982	115	0.9809	165	0.9640	215	0.9474	265	0.9312	315	0.9154	365	0.8999	415	0.8848	465	0.8700
16	1.0154	66	0.9979	116	0.9806	166	0.9637	216	0.9471	266	0.9309	316	0.9151	366	0.8996	416	0.8845	466	0.8697
17	1.0151	67	0.9976	117	0.9802	167	0.9633	217	0.9468	267	0.9306	317	0.9148	367	0.8993	417	0.8842	467	0.8694
18	1.0147	68	0.9972	118	0.9799	168	0.9630	218	0.9464	268	0.9303	318	0.9145	368	0.8990	418	0.8839	468	0.8691
19	1.0144	69	0.9969	119	0.9795	169	0.9627	219	0.9461	269	0.9299	319	0.9141	369	0.8987	419	0.8836	469	0.8688
20	1.0141	70	0.9965	120	0.9792	170	0.9623	220	0.9458	270	0.9296	320	0.9138	370	0.8984	420	0.8833	470	0.8685
21	1.0137	71	0.9962	121	0.9789	171	0.9620	221	0.9454	271	0.9293	321	0.9135	371	0.8981	421	0.8830	471	0.8682
22	1.0134	72	0.9958	122	0.9785	172	0.9616	222	0.9451	272	0.9290	322	0.9132	372	0.8978	422	0.8827	472	0.8679
23	1.0130	73	0.9955	123	0.9782	173	0.9613	223	0.9448	273	0.9287	323	0.9129	373	0.8975	423	0.8824	473	0.8676
24	1.0126	74	0.9952	124	0.9779	174	0.9610	224	0.9445	274	0.9283	324	0.9126	374	0.8972	424	0.8821	474	0.8673
25	1.0123	75	0.9948	125	0.9775	175	0.9606	225	0.9441	275	0.9280	325	0.9123	375	0.8969	425	0.8818	475	0.8671
26	1.0119	76	0.9944	126	0.9772	176	0.9603	226	0.9438	276	0.9277	326	0.9119	376	0.8965	426	0.8815	476	0.8668
27	1.0116	77	0.9941	127	0.9768	177	0.9600	227	0.9435	277	0.9274	327	0.9116	377	0.8962	427	0.8812	477	0.8665
28	1.0112	78	0.9938	128	0.9765	178	0.9596	228	0.9432	278	0.9271	328	0.9113	378	0.8959	428	0.8809	478	0.8662
29	1.0109	79	0.9934	129	0.9762	179	0.9593	229	0.9428	279	0.9267	329	0.9110	379	0.8956	429	0.8806	479	0.8659
30	1.0106	80	0.9931	130	0.9758	180	0.9590	230	0.9425	280	0.9264	330	0.9107	380	0.8953	430	0.8803	480	0.8656
31	1.0102	81	0.9927	131	0.9755	181	0.9586	231	0.9422	281	0.9261	331	0.9104	381	0.8950	431	0.8800	481	0.8653
32	1.0098	82	0.9924	132	0.9751	182	0.9583	232	0.9419	282	0.9258	332	0.9101	382	0.8947	432	0.8797	482	0.8650
33	1.0095	83	0.9920	133	0.9748	183	0.9580	233	0.9415	283	0.9255	333	0.9098	383	0.8944	433	0.8794	483	0.8647
34	1.0092	84	0.9917	134	0.9745	184	0.9576	234	0.9412	284	0.9252	334	0.9095	384	0.8941	434	0.8791	484	0.8644
35	1.0088	85	0.9914	135	0.9741	185	0.9573	235	0.9409	285	0.9248	335	0.9092	385	0.8938	435	0.8788	485	0.8642
36	1.0084	86	0.9910	136	0.9738	186	0.9569	236	0.9406	286	0.9245	336	0.9088	386	0.8935	436	0.8785	486	0.8639
37	1.0081	87	0.9907	137	0.9736	187	0.9566	237	0.9402	287	0.9242	337	0.9085	387	0.8932	437	0.8782	487	0.8636
38	1.0077	88	0.9903	138	0.9731	188	0.9563	238	0.9399	288	0.9239	338	0.9082	388	0.8929	438	0.8779	488	0.8633
39	1.0074	89	0.9900	139	0.9728	189	0.9559	239	0.9396	289	0.9236	339	0.9079	389	0.8926	439	0.8776	489	0.8630
40	1.0070	90	0.9896	140	0.9724	190	0.9556	240	0.9392	290	0.9233	340	0.9076	390	0.8923	440	0.8773	490	0.8627
41	1.0067	91	0.9892	141	0.9721	191	0.9553	241	0.9389	291	0.9229	341	0.9073	391	0.8920	441	0.8770	491	0.8624
42	1.0063	92	0.9889	142	0.9718	192	0.9549	242	0.9386	292	0.9226	342	0.9070	392	0.8917	442	0.8767	492	0.8621
43	1.0059	93	0.9886	143	0.9714	193	0.9546	243	0.9383	293	0.9223	343	0.9067	393	0.8914	443	0.8764	493	0.8618
44	1.0056	94	0.9882	144	0.9711	194	0.9543	244	0.9380	294	0.9220	344	0.9064	394	0.8911	444	0.8762	494	0.8615
45	1.0052	95	0.9879	145	0.9707	195	0.9539	245	0.9376	295	0.9217	345	0.9061	395	0.8908	445	0.8759	495	0.8613
46	1.0049	96	0.9876	146	0.9704	196	0.9536	246	0.9373	296	0.9214	346	0.9057	396	0.8905	446	0.8756	496	0.8610
47	1.0045	97	0.9872	147	0.9701	197	0.9533	247	0.9370	297	0.9210	347	0.9054	397	0.8902	447	0.8753	497	0.8607
48	1.0042	98	0.9869	148	0.9699	198	0.9530	248	0.9367	298	0.9207	348	0.9051	398	0.8899	448	0.8750	498	0.8604
49	1.0039	99	0.9865	149	0.9694	199	0.9527	249	0.9364	299	0.9204	349	0.9048	399	0.8896	449	0.8747	499	0.8601

* These tables for Group 0 and Group 1 have been approved by the Society as volume correction tables for asphaltic products on the joint recommendation

DENSITY AND REFRACTIVE INDEX OF HYDROCARBONS AND PETROLEUM PRODUCTS 1153

GROUP 1*

Legend t = observed temperature in degrees Fahrenheit, M = multiplier for reducing of volumes to the basis of 60° F

t	M	t	M	t	M	t	M	t	M	t	M	t	M	t	M				
0	1.0242	50	1.0040	100	0.9841	150	0.9647	200	0.9457	250	0.9270	300	0.9088	350	0.8909	400	0.8734	450	0.8563
1	1.0238	51	1.0036	101	0.9837	151	0.9643	201	0.9453	251	0.9267	301	0.9084	351	0.8906	401	0.8731	451	0.8560
2	1.0234	52	1.0032	102	0.9833	152	0.9639	202	0.9449	252	0.9263	302	0.9080	352	0.8902	402	0.8727	452	0.8557
3	1.0230	53	1.0028	103	0.9830	153	0.9636	203	0.9446	253	0.9259	303	0.9077	353	0.8899	403	0.8724	453	0.8553
4	1.0226	54	1.0024	104	0.9826	154	0.9632	204	0.9442	254	0.9256	304	0.9073	354	0.8895	404	0.8720	454	0.8550
5	1.0222	55	1.0020	105	0.9822	155	0.9628	205	0.9438	255	0.9252	305	0.9070	355	0.8892	405	0.8717	455	0.8546
6	1.0218	56	1.0016	106	0.9818	156	0.9624	206	0.9434	256	0.9248	306	0.9066	356	0.8888	406	0.8714	456	0.8543
7	1.0214	57	1.0012	107	0.9814	157	0.9620	207	0.9430	257	0.9245	307	0.9063	357	0.8884	407	0.8710	457	0.8540
8	1.0210	58	1.0008	108	0.9811	158	0.9616	208	0.9427	258	0.9241	308	0.9059	358	0.8881	408	0.8707	458	0.8536
9	1.0206	59	1.0004	109	0.9807	159	0.9612	209	0.9423	259	0.9237	309	0.9055	359	0.8877	409	0.8703	459	0.8533
10	1.0202	60	1.0000	110	0.9803	160	0.9608	210	0.9419	260	0.9234	310	0.9052	360	0.8874	410	0.8700	460	0.8530
11	1.0198	61	0.9996	111	0.9799	161	0.9604	211	0.9415	261	0.9230	311	0.9048	361	0.8870	411	0.8696	461	0.8526
12	1.0194	62	0.9992	112	0.9795	162	0.9601	212	0.9412	262	0.9226	312	0.9045	362	0.8867	412	0.8693	462	0.8523
13	1.0189	63	0.9988	113	0.9791	163	0.9597	213	0.9408	263	0.9223	313	0.9041	363	0.8863	413	0.8689	463	0.8519
14	1.0185	64	0.9984	114	0.9787	164	0.9594	214	0.9405	264	0.9219	314	0.9037	364	0.8860	414	0.8686	464	0.8516
15	1.0181	65	0.9980	115	0.9783	165	0.9590	215	0.9401	265	0.9215	315	0.9034	365	0.8856	415	0.8683	465	0.8513
16	1.0177	66	0.9976	116	0.9779	166	0.9586	216	0.9397	266	0.9212	316	0.9030	366	0.8853	416	0.8679	466	0.8510
17	1.0173	67	0.9972	117	0.9775	167	0.9582	217	0.9393	267	0.9208	317	0.9027	367	0.8849	417	0.8676	467	0.8506
18	1.0169	68	0.9968	118	0.9771	168	0.9578	218	0.9390	268	0.9204	318	0.9023	368	0.8846	418	0.8672	468	0.8503
19	1.0165	69	0.9964	119	0.9767	169	0.9574	219	0.9386	269	0.9201	319	0.9020	369	0.8842	419	0.8669	469	0.8499
20	1.0161	70	0.9960	120	0.9763	170	0.9570	220	0.9382	270	0.9197	320	0.9016	370	0.8839	420	0.8665	470	0.8496
21	1.0157	71	0.9956	121	0.9759	171	0.9566	221	0.9378	271	0.9193	321	0.9012	371	0.8835	421	0.8662	471	0.8493
22	1.0153	72	0.9952	122	0.9755	172	0.9562	222	0.9374	272	0.9190	322	0.9009	372	0.8832	422	0.8659	472	0.8489
23	1.0149	73	0.9948	123	0.9752	173	0.9559	223	0.9371	273	0.9186	323	0.9005	373	0.8828	423	0.8655	473	0.8486
24	1.0144	74	0.9944	124	0.9748	174	0.9555	224	0.9367	274	0.9182	324	0.9002	374	0.8825	424	0.8652	474	0.8482
25	1.0140	75	0.9940	125	0.9744	175	0.9551	225	0.9363	275	0.9179	325	0.8998	375	0.8821	425	0.8648	475	0.8479
26	1.0136	76	0.9936	126	0.9740	176	0.9547	226	0.9359	276	0.9175	326	0.8994	376	0.8818	426	0.8645	476	0.8476
27	1.0132	77	0.9932	127	0.9736	177	0.9543	227	0.9356	277	0.9171	327	0.8991	377	0.8814	427	0.8641	477	0.8472
28	1.0128	78	0.9928	128	0.9732	178	0.9540	228	0.9352	278	0.9168	328	0.8987	378	0.8811	428	0.8638	478	0.8469
29	1.0124	79	0.9925	129	0.9728	179	0.9536	229	0.9349	279	0.9164	329	0.8984	379	0.8807	429	0.8635	479	0.8466
30	1.0120	80	0.9921	130	0.9724	180	0.9532	230	0.9345	280	0.9160	330	0.8980	380	0.8804	430	0.8631	480	0.8462
31	1.0116	81	0.9917	131	0.9720	181	0.9528	231	0.9341	281	0.9157	331	0.8977	381	0.8800	431	0.8628	481	0.8459
32	1.0112	82	0.9913	132	0.9716	182	0.9524	232	0.9337	282	0.9153	332	0.8973	382	0.8797	432	0.8624	482	0.8456
33	1.0108	83	0.9909	133	0.9713	183	0.9521	233	0.9334	283	0.9149	333	0.8969	383	0.8793	433	0.8621	483	0.8452
34	1.0104	84	0.9905	134	0.9709	184	0.9517	234	0.9330	284	0.9146	334	0.8966	384	0.8790	434	0.8618	484	0.8449
35	1.0100	85	0.9901	135	0.9705	185	0.9513	235	0.9326	285	0.9142	335	0.8962	385	0.8786	435	0.8614	485	0.8446
36	1.0096	86	0.9897	136	0.9701	186	0.9509	236	0.9322	286	0.9139	336	0.8959	386	0.8783	436	0.8611	486	0.8442
37	1.0092	87	0.9893	137	0.9697	187	0.9505	237	0.9318	287	0.9135	337	0.8955	387	0.8779	437	0.8607	487	0.8439
38	1.0088	88	0.9889	138	0.9694	188	0.9502	238	0.9315	288	0.9131	338	0.8952	388	0.8776	438	0.8604	488	0.8436
39	1.0084	89	0.9885	139	0.9690	189	0.9498	239	0.9311	289	0.9128	339	0.8948	389	0.8772	439	0.8601	489	0.8432
40	1.0080	90	0.9881	140	0.9686	190	0.9494	240	0.9307	290	0.9124	340	0.8945	390	0.8769	440	0.8597	490	0.8429
41	1.0076	91	0.9877	141	0.9682	191	0.9490	241	0.9303	291	0.9120	341	0.8941	391	0.8766	441	0.8594	491	0.8426
42	1.0072	92	0.9873	142	0.9678	192	0.9487	242	0.9300	292	0.9117	342	0.8938	392	0.8762	442	0.8590	492	0.8422
43	1.0068	93	0.9869	143	0.9675	193	0.9483	243	0.9296	293	0.9113	343	0.8934	393	0.8759	443	0.8587	493	0.8419
44	1.0064	94	0.9865	144	0.9671	194	0.9480	244	0.9293	294	0.9110	344	0.8930	394	0.8755	444	0.8584	494	0.8416
45	1.0060	95	0.9861	145	0.9667	195	0.9476	245	0.9289	295	0.9106	345	0.8927	395	0.8752	445	0.8580	495	0.8413
46	1.0056	96	0.9857	146	0.9663	196	0.9472	246	0.9285	296	0.9102	346	0.8923	396	0.8748	446	0.8577	496	0.8409
47	1.0052	97	0.9853	147	0.9659	197	0.9468	247	0.9281	297	0.9099	347	0.8920	397	0.8745	447	0.8573	497	0.8406
48	1.0048	98	0.9849	148	0.9655	198	0.9465	248	0.9278	298	0.9095	348	0.8916	398	0.8741	448	0.8570	498	0.8403
49	1.0044	99	0.9845	149	0.9651	199	0.9461	249	0.9274	299	0.9091	349	0.8913	399	0.8738	449	0.8567	499	0.8399

of ASTM Committee D-4 on Road and Paving Materials and Committee D-8 on Bituminous Waterproofing and Roofing Materials

GROUP 2

Legend t = observed temperature in degrees Fahrenheit, M = multiplier for reducing oil volumes to the basis of 60° F

t	M	t	M	t	M	t	M	t	M
0	1.0297	25	1.0174	50	1.0049	75	0.9925	100	0.9802
1	1.0292	26	1.0169	51	1.0044	76	0.9920	101	0.9797
2	1.0287	27	1.0164	52	1.0039	77	0.9915	102	0.9792
3	1.0283	28	1.0160	53	1.0035	78	0.9911	103	0.9788
4	1.0278	29	1.0154	54	1.0030	79	0.9906	104	0.9781
5	1.0273	30	1.0149	55	1.0025	80	0.9901	105	0.9776
6	1.0268	31	1.0144	56	1.0020	81	0.9896	106	0.9771
7	1.0263	32	1.0139	57	1.0015	82	0.9891	107	0.9766
8	1.0258	33	1.0134	58	1.0010	83	0.9886	108	0.9762
9	1.0253	34	1.0129	59	1.0005	84	0.9881	109	0.9757
10	1.0248	35	1.0124	60	1.0000	85	0.9876	110	0.9752
11	1.0243	36	1.0119	61	0.9995	86	0.9871	111	0.9747
12	1.0238	37	1.0114	62	0.9990	87	0.9866	112	0.9742
13	1.0233	38	1.0109	63	0.9985	88	0.9861	113	0.9737
14	1.0228	39	1.0104	64	0.9980	89	0.9856	114	0.9732
15	1.0223	40	1.0099	65	0.9975	90	0.9851	115	0.9727
16	1.0218	41	1.0094	66	0.9970	91	0.9846	116	0.9722
17	1.0213	42	1.0089	67	0.9965	92	0.9841	117	0.9717
18	1.0208	43	1.0084	68	0.9961	93	0.9836	118	0.9712
19	1.0203	44	1.0079	69	0.9956	94	0.9831	119	0.9707
20	1.0198	45	1.0074	70	0.9951	95	0.9826	120	0.9702
21	1.0193	46	1.0069	71	0.9946	96	0.9821	121	0.9697
22	1.0188	47	1.0064	72	0.9941	97	0.9816	122	0.9692
23	1.0184	48	1.0059	73	0.9936	98	0.9811	123	0.9687
24	1.0179	49	1.0054	74	0.9930	99	0.9806	124	0.9682

GROUP 3

Legend t = observed temperature in degrees Fahrenheit, M = multiplier for reducing oil volumes to the basis of 60° F

t	M	t	M	t	M	t	M	t	M
0	1.0361	25	1.0211	50	1.0060	75	0.9909	100	0.9757
1	1.0355	26	1.0205	51	1.0054	76	0.9903	101	0.9751
2	1.0349	27	1.0199	52	1.0048	77	0.9897	102	0.9745
3	1.0343	28	1.0193	53	1.0042	78	0.9891	103	0.9738
4	1.0337	29	1.0187	54	1.0036	79	0.9885	104	0.9732
5	1.0331	30	1.0181	55	1.0030	80	0.9879	105	0.9726
6	1.0325	31	1.0175	56	1.0024	81	0.9873	106	0.9720
7	1.0319	32	1.0169	57	1.0018	82	0.9867	107	0.9714
8	1.0313	33	1.0163	58	1.0012	83	0.9860	108	0.9708
9	1.0307	34	1.0157	59	1.0006	84	0.9854	109	0.9702
10	1.0301	35	1.0151	60	1.0000	85	0.9848	110	0.9696
11	1.0295	36	1.0145	61	0.9994	86	0.9842	111	0.9690
12	1.0289	37	1.0139	62	0.9988	87	0.9836	112	0.9684
13	1.0283	38	1.0133	63	0.9982	88	0.9830	113	0.9678
14	1.0277	39	1.0127	64	0.9976	89	0.9824	114	0.9672
15	1.0271	40	1.0121	65	0.9970	90	0.9818	115	0.9666
16	1.0265	41	1.0115	66	0.9964	91	0.9812	116	0.9660
17	1.0259	42	1.0109	67	0.9957	92	0.9806	117	0.9654
18	1.0253	43	1.0103	68	0.9951	93	0.9800	118	0.9647
19	1.0247	44	1.0097	69	0.9945	94	0.9794	119	0.9641
20	1.0241	45	1.0091	70	0.9939	95	0.9788	120	0.9635
21	1.0235	46	1.0085	71	0.9933	96	0.9782	121	0.9629
22	1.0229	47	1.0079	72	0.9927	97	0.9776	122	0.9623
23	1.0223	48	1.0073	73	0.9921	98	0.9770	123	0.9617
24	1.0217	49	1.0067	74	0.9915	99	0.9764	124	0.9611

GROUP 4

Legend t = observed temperature in degrees Fahrenheit, M = multiplier for reducing oil volumes to the basis of 60° F

t	M	t	M	t	M	t	M	t	M
0	1.0419	25	1.0246	50	1.0070	75	0.9894	100	0.9716
1	1.0412	26	1.0239	51	1.0063	76	0.9887	101	0.9709
2	1.0405	27	1.0232	52	1.0056	77	0.9880	102	0.9702
3	1.0398	28	1.0225	53	1.0049	78	0.9872	103	0.9695
4	1.0391	29	1.0218	54	1.0042	79	0.9865	104	0.9688
5	1.0384	30	1.0211	55	1.0035	80	0.9858	105	0.9681
6	1.0377	31	1.0204	56	1.0028	81	0.9851	106	0.9674
7	1.0370	32	1.0197	57	1.0021	82	0.9844	107	0.9666
8	1.0364	33	1.0190	58	1.0014	83	0.9837	108	0.9659
9	1.0357	34	1.0183	59	1.0007	84	0.9830	109	0.9652
10	1.0350	35	1.0176	60	1.0000	85	0.9823	110	0.9645
11	1.0343	36	1.0169	61	0.9993	86	0.9816	111	0.9638
12	1.0336	37	1.0162	62	0.9986	87	0.9809	112	0.9631
13	1.0329	38	1.0155	63	0.9979	88	0.9802	113	0.9624
14	1.0322	39	1.0148	64	0.9972	89	0.9795	114	0.9617
15	1.0315	40	1.0141	65	0.9965	90	0.9788	115	0.9609
16	1.0308	41	1.0134	66	0.9958	91	0.9780	116	0.9602
17	1.0301	42	1.0127	67	0.9951	92	0.9773	117	0.9595
18	1.0294	43	1.0120	68	0.9943	93	0.9766	118	0.9588
19	1.0287	44	1.0113	69	0.9936	94	0.9759	119	0.9581
20	1.0280	45	1.0106	70	0.9929	95	0.9752	120	0.9574
21	1.0273	46	1.0099	71	0.9922	96	0.9745	121	0.9567
22	1.0266	47	1.0092	72	0.9915	97	0.9738	122	0.9560
23	1.0260	48	1.0084	73	0.9908	98	0.9731	123	0.9552
24	1.0253	49	1.0077	74	0.9901	99	0.9724	124	0.9545

GROUP 5

Legend t = observed temperature in degrees Fahrenheit, M = multiplier for reducing oil volumes to the basis of 60° F

t	M	t	M	t	M	t	M	t	M
0	1.0476	25	1.0280	50	1.0080	75	0.9879	100	0.9676
1	1.0468	26	1.0272	51	1.0072	76	0.9871	101	0.9668
2	1.0460	27	1.0264	52	1.0064	77	0.9863	102	0.9660
3	1.0453	28	1.0256	53	1.0056	78	0.9854	103	0.9652
4	1.0445	29	1.0248	54	1.0048	79	0.9846	104	0.9643
5	1.0437	30	1.0240	55	1.0040	80	0.9838	105	0.9635
6	1.0429	31	1.0232	56	1.0032	81	0.9830	106	0.9627
7	1.0421	32	1.0224	57	1.0024	82	0.9822	107	0.9619
8	1.0414	33	1.0216	58	1.0016	83	0.9814	108	0.9611
9	1.0406	34	1.0208	59	1.0008	84	0.9806	109	0.9603
10	1.0398	35	1.0200	60	1.0000	85	0.9798	110	0.9595
11	1.0390	36	1.0192	61	0.9992	86	0.9790	111	0.9586
12	1.0382	37	1.0184	62	0.9984	87	0.9782	112	0.9578
13	1.0375	38	1.0176	63	0.9976	88	0.9773	113	0.9570
14	1.0367	39	1.0168	64	0.9968	89	0.9765	114	0.9562
15	1.0359	40	1.0160	65	0.9960	90	0.9757	115	0.9554
16	1.0351	41	1.0152	66	0.9952	91	0.9749	116	0.9546
17	1.0343	42	1.0144	67	0.9944	92	0.9741	117	0.9538
18	1.0335	43	1.0136	68	0.9935	93	0.9733	118	0.9529
19	1.0327	44	1.0128	69	0.9927	94	0.9725	119	0.9521
20	1.0319	45	1.0120	70	0.9919	95	0.9717	120	0.9513
21	1.0311	46	1.0112	71	0.9911	96	0.9709	121	0.9505
22	1.0303	47	1.0104	72	0.9903	97	0.9700	122	0.9497
23	1.0296	48	1.0096	73	0.9895	98	0.9692	123	0.9489
24	1.0288	49	1.0088	74	0.9887	99	0.9684	124	0.9480

DENSITY AND REFRACTIVE INDEX OF HYDROCARBONS AND PETROLEUM PRODUCTS 1155

GROUP 6

Legend t = observed temperature in degrees Fahrenheit,
 M = multiplier for reducing oil volumes to the basis of 60° F

t	M	t	M	t	M	t	M	t	M
0	1 0501	25	1 0294	50	1 0084	75	0 9873	100	0 9659
1	1 0493	26	1 0286	51	1 0076	76	0 9864	101	0 9650
2	1 0484	27	1 0277	52	1 0067	77	0 9856	102	0 9642
3	1 0476	28	1 0269	53	1 0059	78	0 9847	103	0 9633
4	1 0467	29	1 0260	54	1 0050	79	0 9839	104	0 9625
5	1 0459	30	1 0252	55	1 0042	80	0 9830	105	0 9616
6	1 0451	31	1 0244	56	1 0034	81	0 9821	106	0 9608
7	1 0443	32	1 0236	57	1 0025	82	0 9813	107	0 9599
8	1 0434	33	1 0227	58	1 0017	83	0 9804	108	0 9590
9	1 0426	34	1 0219	59	1 0008	84	0 9796	109	0 9582
10	1 0418	35	1 0211	60	1 0000	85	0 9787	110	0 9573
11	1 0410	36	1 0203	61	0 9992	86	0 9779	111	0 9565
12	1 0402	37	1 0194	62	0 9983	87	0 9770	112	0 9556
13	1 0393	38	1 0186	63	0 9975	88	0 9762	113	0 9548
14	1 0385	39	1 0177	64	0 9966	89	0 9753	114	0 9539
15	1 0377	40	1 0169	65	0 9958	90	0 9745	115	0 9530
16	1 0369	41	1 0160	66	0 9949	91	0 9736	116	0 9522
17	1 0360	42	1 0152	67	0 9941	92	0 9727	117	0 9513
18	1 0352	43	1 0143	68	0 9932	93	0 9719	118	0 9505
19	1 0343	44	1 0135	69	0 9924	94	0 9710	119	0 9496
20	1 0335	45	1 0126	70	0 9915	95	0 9702	120	0 9487
21	1 0327	46	1 0118	71	0 9907	96	0 9693	121	0 9479
22	1 0319	47	1 0110	72	0 9898	97	0 9685	122	0 9470
23	1 0310	48	1 0101	73	0 9890	98	0 9676	123	0 9462
24	1 0302	49	1 0093	74	0 9881	99	0 9668	124	0 9453

GROUP 7

Legend t = observed temperature in degrees Fahrenheit,
 M = multiplier for reducing oil volumes to the basis of 60° F

t	M	t	M	t	M	t	M
0	1 0511	25	1 0312	50	1 0090	75	0 9865
1	1 0522	26	1 0303	51	1 0081	76	0 9856
2	1 0513	27	1 0294	52	1 0072	77	0 9847
3	1 0505	28	1 0286	53	1 0063	78	0 9838
4	1 0496	29	1 0277	54	1 0054	79	0 9829
5	1 0487	30	1 0268	55	1 0045	80	0 9820
6	1 0478	31	1 0259	56	1 0036	81	0 9811
7	1 0470	32	1 0250	57	1 0027	82	0 9802
8	1 0461	33	1 0242	58	1 0018	83	0 9792
9	1 0453	34	1 0233	59	1 0009	84	0 9783
10	1 0444	35	1 0224	60	1 0000	85	0 9774
11	1 0435	36	1 0215	61	0 9991	86	0 9765
12	1 0426	37	1 0206	62	0 9982	87	0 9756
13	1 0418	38	1 0197	63	0 9973	88	0 9747
14	1 0409	39	1 0188	64	0 9964	89	0 9738
15	1 0400	40	1 0179	65	0 9955	90	0 9729
16	1 0391	41	1 0170	66	0 9946	91	0 9719
17	1 0382	42	1 0161	67	0 9937	92	0 9710
18	1 0374	43	1 0152	68	0 9928	93	0 9701
19	1 0365	44	1 0143	69	0 9919	94	0 9692
20	1 0356	45	1 0134	70	0 9910	95	0 9683
21	1 0347	46	1 0125	71	0 9901	96	0 9674
22	1 0338	47	1 0116	72	0 9892	97	0 9665
23	1 0330	48	1 0108	73	0 9883	98	0 9656
24	1 0321	49	1 0099	74	0 9874	99	0 9647

APPENDIX C

These tables should not be used for oils containing crystalline wax

REDUCTION OF OBSERVED DEGREES API TO DEGREES API AT 60° F.

(From Bureau of Standards Circular C. 410, 1936)

This table shows the degrees API at 60° F. of oils having, at the observed temperatures, the degrees API indicated. For example, if the observed degrees API at 78° F. is 20.0, the degrees API at 60° F. will be 19.0. Intermediate values can be conveniently interpolated. For example, if the observed degrees API at 78° F. is 20.4, the degrees API at

60° F. will be 19.4. The headings "Observed degrees API" and "Observed temperature" signify the indication of the hydrometer and the true temperature of the oil, that is, the observed readings corrected for meniscus errors. (This table is so computed as to take into account the thermal expansion of the glass of which the hydrometer is made.)

Observed temperature in ° F.	Observed degrees API										Observed temperature in ° F.	Observed degrees API									
	10	11	12	13	14	15	16	17	18	19		10	11	12	13	14	15	16	17	18	19
0	13.1	14.1	15.1	16.1	17.1	18.1	19.1	20.1	21.1	22.1	23.1	24.1	25.1	26.1	27.1	28.1	29.1	30.1	31.1	32.1	
1	13.0	14.0	15.0	16.0	17.0	18.0	19.0	20.0	21.0	22.0	23.0	24.0	25.0	26.0	27.0	28.0	29.0	30.0	31.0	32.0	
2	12.9	13.9	14.9	15.9	16.9	17.9	18.9	19.9	20.9	21.9	22.9	23.9	24.9	25.9	26.9	27.9	28.9	29.9	30.9	31.9	
3	12.9	13.9	14.9	15.9	16.9	17.9	18.9	19.9	20.9	21.9	22.9	23.9	24.9	25.9	26.9	27.9	28.9	29.9	30.9	31.9	
4	12.9	13.9	14.9	15.9	16.9	17.9	18.9	19.9	20.9	21.9	22.9	23.9	24.9	25.9	26.9	27.9	28.9	29.9	30.9	31.9	
5	12.8	13.8	14.8	15.8	16.8	17.8	18.8	19.8	20.8	21.8	22.8	23.8	24.8	25.8	26.8	27.8	28.8	29.8	30.8	31.8	
6	12.8	13.8	14.8	15.8	16.8	17.8	18.8	19.8	20.8	21.8	22.8	23.8	24.8	25.8	26.8	27.8	28.8	29.8	30.8	31.8	
7	12.7	13.7	14.7	15.7	16.7	17.7	18.7	19.7	20.7	21.7	22.7	23.7	24.7	25.7	26.7	27.7	28.7	29.7	30.7	31.7	
8	12.7	13.7	14.7	15.7	16.7	17.7	18.7	19.7	20.7	21.7	22.7	23.7	24.7	25.7	26.7	27.7	28.7	29.7	30.7	31.7	
9	12.6	13.6	14.6	15.6	16.6	17.6	18.6	19.6	20.6	21.6	22.6	23.6	24.6	25.6	26.6	27.6	28.6	29.6	30.6	31.6	
10	12.6	13.6	14.6	15.6	16.6	17.6	18.6	19.6	20.6	21.6	22.6	23.6	24.6	25.6	26.6	27.6	28.6	29.6	30.6	31.6	
11	12.5	13.5	14.5	15.5	16.5	17.5	18.5	19.5	20.5	21.5	22.5	23.5	24.5	25.5	26.5	27.5	28.5	29.5	30.5	31.5	
12	12.5	13.5	14.5	15.5	16.5	17.5	18.5	19.5	20.5	21.5	22.5	23.5	24.5	25.5	26.5	27.5	28.5	29.5	30.5	31.5	
13	12.4	13.4	14.4	15.4	16.4	17.4	18.4	19.4	20.4	21.4	22.4	23.4	24.4	25.4	26.4	27.4	28.4	29.4	30.4	31.4	
14	12.4	13.4	14.4	15.4	16.4	17.4	18.4	19.4	20.4	21.4	22.4	23.4	24.4	25.4	26.4	27.4	28.4	29.4	30.4	31.4	
15	12.3	13.3	14.3	15.3	16.3	17.3	18.3	19.3	20.3	21.3	22.3	23.3	24.3	25.3	26.3	27.3	28.3	29.3	30.3	31.3	
16	12.2	13.2	14.2	15.2	16.2	17.2	18.2	19.2	20.2	21.2	22.2	23.2	24.2	25.2	26.2	27.2	28.2	29.2	30.2	31.2	
17	12.2	13.2	14.2	15.2	16.2	17.2	18.2	19.2	20.2	21.2	22.2	23.2	24.2	25.2	26.2	27.2	28.2	29.2	30.2	31.2	
18	12.1	13.1	14.1	15.1	16.1	17.1	18.1	19.1	20.1	21.1	22.1	23.1	24.1	25.1	26.1	27.1	28.1	29.1	30.1	31.1	
19	12.1	13.1	14.1	15.1	16.1	17.1	18.1	19.1	20.1	21.1	22.1	23.1	24.1	25.1	26.1	27.1	28.1	29.1	30.1	31.1	
20	12.0	13.0	14.0	15.0	16.0	17.0	18.0	19.0	20.0	21.0	22.0	23.0	24.0	25.0	26.0	27.0	28.0	29.0	30.0	31.0	
21	12.0	13.0	14.0	15.0	16.0	17.0	18.0	19.0	20.0	21.0	22.0	23.0	24.0	25.0	26.0	27.0	28.0	29.0	30.0	31.0	
22	11.9	12.9	13.9	14.9	15.9	16.9	17.9	18.9	19.9	20.9	21.9	22.9	23.9	24.9	25.9	26.9	27.9	28.9	29.9	30.9	
23	11.8	12.8	13.8	14.8	15.8	16.8	17.8	18.8	19.8	20.8	21.8	22.8	23.8	24.8	25.8	26.8	27.8	28.8	29.8	30.8	
24	11.8	12.8	13.8	14.8	15.8	16.8	17.8	18.8	19.8	20.8	21.8	22.8	23.8	24.8	25.8	26.8	27.8	28.8	29.8	30.8	
25	11.7	12.7	13.7	14.7	15.7	16.7	17.7	18.7	19.7	20.7	21.7	22.7	23.7	24.7	25.7	26.7	27.7	28.7	29.7	30.7	
26	11.7	12.7	13.7	14.7	15.7	16.7	17.7	18.7	19.7	20.7	21.7	22.7	23.7	24.7	25.7	26.7	27.7	28.7	29.7	30.7	
27	11.6	12.6	13.6	14.6	15.6	16.6	17.6	18.6	19.6	20.6	21.6	22.6	23.6	24.6	25.6	26.6	27.6	28.6	29.6	30.6	
28	11.6	12.6	13.6	14.6	15.6	16.6	17.6	18.6	19.6	20.6	21.6	22.6	23.6	24.6	25.6	26.6	27.6	28.6	29.6	30.6	
29	11.5	12.5	13.5	14.5	15.5	16.5	17.5	18.5	19.5	20.5	21.5	22.5	23.5	24.5	25.5	26.5	27.5	28.5	29.5	30.5	
30	11.5	12.5	13.5	14.5	15.5	16.5	17.5	18.5	19.5	20.5	21.5	22.5	23.5	24.5	25.5	26.5	27.5	28.5	29.5	30.5	
31	11.4	12.4	13.4	14.4	15.4	16.4	17.4	18.4	19.4	20.4	21.4	22.4	23.4	24.4	25.4	26.4	27.4	28.4	29.4	30.4	
32	11.4	12.4	13.4	14.4	15.4	16.4	17.4	18.4	19.4	20.4	21.4	22.4	23.4	24.4	25.4	26.4	27.4	28.4	29.4	30.4	
33	11.3	12.3	13.3	14.3	15.3	16.3	17.3	18.3	19.3	20.3	21.3	22.3	23.3	24.3	25.3	26.3	27.3	28.3	29.3	30.3	
34	11.3	12.3	13.3	14.3	15.3	16.3	17.3	18.3	19.3	20.3	21.3	22.3	23.3	24.3	25.3	26.3	27.3	28.3	29.3	30.3	
35	11.2	12.2	13.2	14.2	15.2	16.2	17.2	18.2	19.2	20.2	21.2	22.2	23.2	24.2	25.2	26.2	27.2	28.2	29.2	30.2	
36	11.2	12.2	13.2	14.2	15.2	16.2	17.2	18.2	19.2	20.2	21.2	22.2	23.2	24.2	25.2	26.2	27.2	28.2	29.2	30.2	
37	11.1	12.1	13.1	14.1	15.1	16.1	17.1	18.1	19.1	20.1	21.1	22.1	23.1	24.1	25.1	26.1	27.1	28.1	29.1	30.1	
38	11.1	12.1	13.1	14.1	15.1	16.1	17.1	18.1	19.1	20.1	21.1	22.1	23.1	24.1	25.1	26.1	27.1	28.1	29.1	30.1	

DENSITY AND REFRACTIVE INDEX OF HYDROCARBONS AND PETROLEUM PRODUCTS

1157

40	110	120	130	140	150	160	170	180	190	200	140	62	72	81	91	100	109	119	128	138	147
41	110	120	130	140	150	160	170	180	190	200	141	62	71	80	90	100	109	118	127	137	147
42	110	120	130	140	150	160	170	180	190	200	142	61	71	80	90	100	109	118	127	137	147
43	110	120	130	140	150	160	170	180	190	200	143	61	70	79	89	99	108	117	126	136	146
44	108	118	128	138	148	158	168	178	188	199	144	60	70	79	89	98	107	117	126	136	145
45	107	118	128	138	148	158	168	178	188	199	145	60	69	79	88	97	106	115	125	135	145
46	107	117	127	137	148	158	168	178	188	198	146	59	69	78	88	97	106	115	125	135	144
47	106	116	126	136	146	156	166	176	186	197	147	59	69	78	87	96	105	115	125	135	144
48	106	116	126	136	146	156	166	176	186	196	148	58	68	77	87	96	105	115	125	135	144
49	105	115	125	135	145	155	165	175	185	196	149	58	67	77	86	95	105	115	125	135	144
50	105	115	125	135	145	155	165	175	185	196	150	58	67	77	86	95	105	115	125	135	144
51	105	115	125	135	145	155	165	175	185	195	151	57	67	76	86	95	104	114	124	134	144
52	105	115	125	135	145	155	165	175	185	195	152	57	66	76	85	94	104	114	124	134	144
53	105	114	124	134	144	154	164	174	184	194	153	57	66	75	85	94	104	114	124	134	144
54	105	113	123	133	143	153	163	173	183	193	154	56	65	75	84	94	104	114	124	134	144
55	105	113	123	133	143	153	163	173	183	193	155	56	65	74	84	94	104	114	124	134	144
56	102	112	122	132	142	152	162	172	182	192	156	55	64	74	83	93	103	113	123	133	143
57	102	112	122	132	142	152	162	172	182	192	157	54	64	73	83	93	103	113	123	133	143
58	102	111	121	131	141	151	161	171	181	191	158	54	63	73	82	92	102	112	122	132	142
59	100	110	120	130	140	150	160	170	180	190	159	54	63	73	82	91	101	111	121	131	141
60	110	120	130	140	150	160	170	180	190	200	160	53	63	72	81	91	100	109	118	128	137
61	109	119	129	139	149	159	169	179	189	199	161	53	62	72	81	90	100	109	118	127	136
62	109	118	128	138	148	158	168	178	188	198	162	52	62	71	80	90	100	109	118	127	136
63	108	118	128	138	148	158	168	178	188	198	163	52	61	71	80	90	100	109	118	127	136
64	108	118	128	138	148	158	168	178	188	198	164	52	61	70	80	90	100	109	117	126	135
65	107	117	127	137	147	157	167	177	187	197	165	51	61	70	79	89	99	108	117	126	135
66	107	117	127	137	147	157	167	177	187	197	166	51	60	69	79	88	97	106	115	125	134
67	106	116	126	136	146	156	166	176	186	196	167	50	60	69	78	87	96	105	115	124	133
68	106	116	126	136	146	156	166	176	186	196	168	50	59	68	77	86	95	104	114	123	132
69	106	115	125	135	145	155	165	175	185	195	169	50	59	68	77	86	95	104	114	123	132
70	105	115	125	135	145	155	165	175	185	195	170	49	59	68	77	86	95	105	114	123	132
71	105	114	124	134	144	154	164	174	184	194	171	49	58	67	77	86	95	104	113	122	131
72	105	114	124	134	144	154	164	174	184	194	172	49	58	67	76	85	94	103	112	121	130
73	104	114	124	134	144	154	164	174	184	194	173	48	57	67	76	85	94	103	112	121	130
74	103	113	123	133	143	153	163	173	183	193	174	48	57	66	76	85	94	103	112	121	130
75	103	112	122	132	142	152	162	172	182	192	175	47	56	66	75	84	93	102	112	121	130
76	102	112	122	132	142	152	162	172	182	192	176	47	56	65	75	84	93	102	111	120	129
77	102	111	121	131	141	151	161	171	181	191	177	46	55	65	74	83	92	101	110	119	128
78	101	111	121	131	141	151	161	171	181	191	178	46	55	64	74	83	92	101	110	119	128
79	101	110	120	130	140	150	160	170	180	190	179	46	55	64	73	82	92	101	110	119	128
80	110	120	130	140	150	160	170	180	190	200	180	45	54	64	73	82	91	100	109	118	127
81	109	119	129	139	149	159	169	179	189	199	181	45	54	63	73	82	91	100	109	118	127
82	109	118	128	138	148	158	168	178	188	198	182	45	54	63	72	81	90	99	108	117	126
83	108	118	128	138	148	158	168	178	188	198	183	44	53	62	72	81	90	99	108	117	126
84	108	118	128	138	148	158	168	178	188	198	184	43	53	62	71	80	89	98	107	116	125
85	108	117	127	137	147	157	167	177	187	197	185	43	52	61	71	80	89	98	107	116	125
86	107	117	127	137	147	157	167	177	187	197	186	43	52	61	70	79	88	97	106	115	124
87	107	116	126	136	146	156	166	176	186	196	187	42	51	60	70	79	88	97	106	115	124
88	106	116	126	136	146	156	166	176	186	196	188	42	51	60	69	78	87	96	105	114	123
89	106	115	125	135	145	155	165	175	185	195	189	41	50	60	69	78	87	96	105	114	123
90	105	115	125	135	145	155	165	175	185	195	190	41	50	59	69	78	87	96	105	114	123
91	105	114	124	134	144	154	164	174	184	194	191	41	50	59	68	77	86	95	104	113	122
92	105	114	124	134	144	154	164	174	184	194	192	40	49	58	67	76	85	94	103	112	121
93	105	113	123	133	143	153	163	173	183	193	193	40	49	58	67	76	85	94	103	112	121
94	103	113	123	133	143	153	163	173	183	193	194	39	49	58	67	76	85	94	103	112	121
95	103	112	122	132	142	152	162	172	182	192	195	39	48	57	66	75	84	93	102	111	120
96	102	112	122	132	142	152	162	172	182	192	196	39	48	57	66	75	84	93	102	111	120
97	102	111	121	131	141	151	161	171	181	191	197	39	48	57	66	75	84	93	102	111	120
98	101	111	121	131	141	151	161	171	181	191	198	39	48	57	66	75	84	93	102	111	120
99	101	110	120	130	140	150	160	170	180	190	199	39	48	57	66	75	84	93	102	111	120
200	101	110	120	130	140	150	160	170	180	190	200	39	48	57	66	75	84	93	102	111	120

For observation temperatures from 0 to 9°F see Appendix at the end of the last volume

PHYSICAL AND CHEMICAL PROPERTIES

APPENDIX C (cont)

Reduction of Observed Degrees API to Degrees API at 60° F. (cont)

Observed temperature in ° F.	Observed degrees API										Observed temperature in ° F.	Observed degrees API																										
	Corresponding degrees API at 60° F.					Corresponding degrees API at 60° F.						Corresponding degrees API at 60° F.					Corresponding degrees API at 60° F.																					
	20	21	22	23	24	25	26	27	28	29		20	21	22	23	24	25	26	27	28	29	20	21	22	23	24	25	26	27	28	29							
0	23.6	24.6	25.7	26.8	27.8	28.9	30.0	31.0	32.1	33.2	100	17.8	18.7	19.7	20.7	21.6	22.5	23.5	24.5	25.5	26.5	27.5	28.5	29.5	30.5	31.5	32.5	33.5	34.5	35.5	36.5	37.5	38.5	39.5	40.5			
1	23.5	24.5	25.6	26.7	27.7	28.8	29.9	31.0	32.0	33.1	101	17.7	18.6	19.6	20.6	21.5	22.4	23.4	24.4	25.4	26.4	27.4	28.4	29.4	30.4	31.4	32.4	33.4	34.4	35.4	36.4	37.4	38.4	39.4	40.4			
2	23.4	24.4	25.5	26.6	27.6	28.7	29.8	30.9	31.9	33.0	102	17.6	18.5	19.5	20.5	21.4	22.3	23.3	24.3	25.3	26.3	27.3	28.3	29.3	30.3	31.3	32.3	33.3	34.3	35.3	36.3	37.3	38.3	39.3	40.3			
3	23.3	24.3	25.4	26.5	27.5	28.6	29.7	30.8	31.8	32.9	103	17.5	18.4	19.4	20.4	21.3	22.2	23.2	24.2	25.2	26.2	27.2	28.2	29.2	30.2	31.2	32.2	33.2	34.2	35.2	36.2	37.2	38.2	39.2	40.2			
4	23.2	24.2	25.3	26.4	27.4	28.5	29.6	30.6	31.7	32.8	104	17.4	18.3	19.3	20.3	21.2	22.1	23.1	24.1	25.1	26.1	27.1	28.1	29.1	30.1	31.1	32.1	33.1	34.1	35.1	36.1	37.1	38.1	39.1	40.1			
5	23.1	24.1	25.2	26.3	27.3	28.4	29.5	30.5	31.6	32.7	105	17.3	18.2	19.2	20.2	21.1	22.0	23.0	24.0	25.0	26.0	27.0	28.0	29.0	30.0	31.0	32.0	33.0	34.0	35.0	36.0	37.0	38.0	39.0	40.0			
6	23.0	24.0	25.1	26.2	27.2	28.3	29.4	30.4	31.4	32.5	106	17.2	18.1	19.1	20.1	21.0	21.9	22.9	23.9	24.9	25.9	26.9	27.9	28.9	29.9	30.9	31.9	32.9	33.9	34.9	35.9	36.9	37.9	38.9	39.9	40.9		
7	22.9	23.9	25.0	26.1	27.1	28.2	29.3	30.3	31.3	32.4	107	17.1	18.0	19.0	20.0	20.9	21.8	22.8	23.8	24.8	25.8	26.8	27.8	28.8	29.8	30.8	31.8	32.8	33.8	34.8	35.8	36.8	37.8	38.8	39.8	40.8		
8	22.8	23.8	24.9	26.0	27.0	28.1	29.1	30.2	31.2	32.3	108	17.0	17.9	18.9	19.9	20.8	21.7	22.7	23.7	24.7	25.7	26.7	27.7	28.7	29.7	30.7	31.7	32.7	33.7	34.7	35.7	36.7	37.7	38.7	39.7	40.7		
9	22.7	23.7	24.8	25.9	26.9	28.0	29.0	30.0	31.1	32.1	109	16.9	17.8	18.8	19.8	20.7	21.6	22.6	23.6	24.6	25.6	26.6	27.6	28.6	29.6	30.6	31.6	32.6	33.6	34.6	35.6	36.6	37.6	38.6	39.6	40.6		
10	22.6	23.6	24.7	25.8	26.8	27.8	28.8	29.8	30.8	31.8	110	16.8	17.7	18.7	19.7	20.6	21.5	22.5	23.5	24.5	25.5	26.5	27.5	28.5	29.5	30.5	31.5	32.5	33.5	34.5	35.5	36.5	37.5	38.5	39.5	40.5		
11	22.5	23.5	24.6	25.7	26.7	27.7	28.7	29.7	30.7	31.7	111	16.7	17.6	18.6	19.6	20.5	21.4	22.4	23.4	24.4	25.4	26.4	27.4	28.4	29.4	30.4	31.4	32.4	33.4	34.4	35.4	36.4	37.4	38.4	39.4	40.4		
12	22.4	23.4	24.5	25.6	26.6	27.6	28.6	29.6	30.6	31.6	112	16.6	17.5	18.5	19.5	20.4	21.3	22.3	23.3	24.3	25.3	26.3	27.3	28.3	29.3	30.3	31.3	32.3	33.3	34.3	35.3	36.3	37.3	38.3	39.3	40.3		
13	22.3	23.3	24.4	25.5	26.5	27.5	28.5	29.5	30.5	31.5	113	16.5	17.4	18.4	19.4	20.3	21.2	22.2	23.2	24.2	25.2	26.2	27.2	28.2	29.2	30.2	31.2	32.2	33.2	34.2	35.2	36.2	37.2	38.2	39.2	40.2		
14	22.2	23.2	24.3	25.4	26.4	27.4	28.4	29.4	30.4	31.4	114	16.4	17.3	18.3	19.3	20.2	21.1	22.1	23.1	24.1	25.1	26.1	27.1	28.1	29.1	30.1	31.1	32.1	33.1	34.1	35.1	36.1	37.1	38.1	39.1	40.1		
15	22.1	23.1	24.2	25.3	26.3	27.3	28.3	29.3	30.3	31.3	115	16.3	17.2	18.2	19.2	20.1	21.0	22.0	23.0	24.0	25.0	26.0	27.0	28.0	29.0	30.0	31.0	32.0	33.0	34.0	35.0	36.0	37.0	38.0	39.0	40.0		
16	22.0	23.0	24.1	25.2	26.2	27.2	28.2	29.2	30.2	31.2	116	16.2	17.1	18.1	19.1	20.0	20.9	21.9	22.9	23.9	24.9	25.9	26.9	27.9	28.9	29.9	30.9	31.9	32.9	33.9	34.9	35.9	36.9	37.9	38.9	39.9	40.9	
17	21.9	22.9	24.0	25.1	26.1	27.1	28.1	29.1	30.1	31.1	117	16.1	17.0	18.0	19.0	19.9	20.8	21.8	22.8	23.8	24.8	25.8	26.8	27.8	28.8	29.8	30.8	31.8	32.8	33.8	34.8	35.8	36.8	37.8	38.8	39.8	40.8	
18	21.8	22.8	23.9	25.0	26.0	27.0	28.0	29.0	30.0	31.0	118	16.0	16.9	17.9	18.9	19.8	20.7	21.7	22.7	23.7	24.7	25.7	26.7	27.7	28.7	29.7	30.7	31.7	32.7	33.7	34.7	35.7	36.7	37.7	38.7	39.7	40.7	
19	21.7	22.7	23.8	24.9	25.9	26.9	27.9	28.9	29.9	30.9	119	15.9	16.8	17.8	18.8	19.7	20.6	21.5	22.5	23.5	24.5	25.5	26.5	27.5	28.5	29.5	30.5	31.5	32.5	33.5	34.5	35.5	36.5	37.5	38.5	39.5	40.5	
20	21.6	22.6	23.7	24.8	25.8	26.8	27.8	28.8	29.8	30.8	120	15.8	16.7	17.7	18.7	19.6	20.5	21.4	22.4	23.4	24.4	25.4	26.4	27.4	28.4	29.4	30.4	31.4	32.4	33.4	34.4	35.4	36.4	37.4	38.4	39.4	40.4	
21	21.5	22.5	23.6	24.7	25.7	26.7	27.7	28.7	29.7	30.7	121	15.7	16.6	17.6	18.6	19.5	20.4	21.3	22.3	23.3	24.3	25.3	26.3	27.3	28.3	29.3	30.3	31.3	32.3	33.3	34.3	35.3	36.3	37.3	38.3	39.3	40.3	
22	21.4	22.4	23.5	24.6	25.6	26.6	27.6	28.6	29.6	30.6	122	15.6	16.5	17.5	18.5	19.4	20.3	21.2	22.2	23.2	24.2	25.2	26.2	27.2	28.2	29.2	30.2	31.2	32.2	33.2	34.2	35.2	36.2	37.2	38.2	39.2	40.2	
23	21.3	22.3	23.4	24.5	25.5	26.5	27.5	28.5	29.5	30.5	123	15.5	16.4	17.4	18.4	19.3	20.2	21.1	22.1	23.1	24.1	25.1	26.1	27.1	28.1	29.1	30.1	31.1	32.1	33.1	34.1	35.1	36.1	37.1	38.1	39.1	40.1	
24	21.2	22.2	23.3	24.4	25.4	26.4	27.4	28.4	29.4	30.4	124	15.4	16.3	17.3	18.3	19.2	20.1	21.0	22.0	23.0	24.0	25.0	26.0	27.0	28.0	29.0	30.0	31.0	32.0	33.0	34.0	35.0	36.0	37.0	38.0	39.0	40.0	
25	21.1	22.1	23.2	24.3	25.3	26.3	27.3	28.3	29.3	30.3	125	15.3	16.2	17.2	18.2	19.1	20.0	20.9	21.9	22.9	23.9	24.9	25.9	26.9	27.9	28.9	29.9	30.9	31.9	32.9	33.9	34.9	35.9	36.9	37.9	38.9	39.9	40.9
26	21.0	22.0	23.1	24.2	25.2	26.2	27.2	28.2	29.2	30.2	126	15.2	16.1	17.1	18.1	19.0	19.9	20.8	21.8	22.8	23.8	24.8	25.8	26.8	27.8	28.8	29.8	30.8	31.8	32.8	33.8	34.8	35.8	36.8	37.8	38.8	39.8	40.8
27	20.9	21.9	23.0	24.1	25.1	26.1	27.1	28.1	29.1	30.1	127	15.1	16.0	17.0	18.0	18.9	19.8	20.7	21.7	22.7	23.7	24.7	25.7	26.7	27.7	28.7	29.7	30.7	31.7	32.7	33.7	34.7	35.7	36.7	37.7	38.7	39.7	40.7
28	20.8	21.8	22.9	24.0	25.0	26.0	27.0	28.0	29.0	30.0	128	15.0	15.9	16.9	17.9	18.8	19.7	20.6	21.5	22.5	23.5	24.5	25.5	26.5	27.5	28.5	29.5	30.5	31.5	32.5	33.5	34.5	35.5	36.5	37.5	38.5	39.5	40.5
29	20.7	21.7	22.8	23.9	24.9	25.9	26.9	27.9	28.9	29.9	129	14.9	15.8	16.8	17.8	18.7	19.6	20.5	21.4	22.4	23.4	24.4	25.4	26.4	27.4	28.4	29.4	30.4	31.4	32.4	33.4	34.4	35.4	36.4	37.4	38.4	39.4	40.4
30	20.6	21.6	22.7	23.8	24.8	25.8	26.8	27.8	28.8	29.8	130	14.8	15.7	16.7	17.7	18.6	19.5	20.4	21.3	22.3	23.3	24.3	25.3	26.3	27.3	28.3	29.3	30.3	31.3	32.3	33.3	34.3	35.3	36.3	37.3	38.3	39.3	40.3
31	20.5	21.5	22.6	23.7	24.7	25.7	26.7	27.7	28.7	29.7	131	14.7	15.6	16.6	17.6	18.5	19.4	20.3	21.2	22.2	23.2	24.2	25.2	26.2	27.2	28.2	29.2	30.2	31.2	32.2	33.2	34.2	35.2	36.2	37.2	38.2	39.2	40.2
32	20.4	21.4	22.5	23.6	24.6	25.6	26.6	27.6	28.6	29.6	132	14.6	15.5	16.5	17.5	18.4	19.3	20.2	21.1	22.1	23.1	24.1	25.1	26.1	27.1	28.1	29.1	30.1	31.1	32.1	33.1	34.1	35.1	36.1	37.1	38.1	39.1	40.1
33	20.3	21.3	22.4	23.5	24.5	25.5	26.5	27.5	28.5	29.5	133	14.5	15.4	16.4	17.4	18.3	19.2	20.1	21.0	22.0	23.0	24.0	25.0	26.0	27.0	28.0	29.0	30.0	31.0	32.0	33.0	34.0	35.0	36.0	37.0	38.0	39.0	40.0
34	20.2	21.2	22.3	23.4	24.4	25.4	26.4	27.4	28.4	29.4	134	14.4	15.3	16.3	17.3	18.2	19.1	20.0	20.9	21.9	22.9	23.9	24.9	25.														

DENSITY AND REFRACTIVE INDEX OF HYDROCARBONS AND PETROLEUM PRODUCTS 1159

45	209	219	228	219	249	259	289	309	349	359	389	399	445	154	163	173	182	191	200	310	319	329	331
46	208	218	228	218	248	258	279	299	289	269	279	299	346	146	155	165	174	183	192	201	210	220	222
47	207	217	227	217	247	257	277	297	287	267	277	297	345	145	154	164	173	182	191	200	209	219	221
48	206	216	226	216	246	256	276	296	286	266	276	296	344	144	153	163	172	181	190	200	209	219	221
49	205	215	225	215	245	255	275	295	285	265	275	295	343	143	152	162	171	180	189	200	209	219	221
50	204	214	224	214	244	254	274	294	284	264	274	294	342	142	151	161	170	179	188	200	209	219	221
51	203	213	223	213	243	253	273	293	283	263	273	293	341	141	150	160	169	178	187	200	209	219	221
52	202	212	222	212	242	252	272	292	282	262	272	292	340	140	149	159	168	177	186	200	209	219	221
53	201	211	221	211	241	251	271	291	281	261	271	291	339	139	148	158	167	176	185	200	209	219	221
54	200	210	220	210	240	250	270	290	280	260	270	290	338	138	147	157	166	175	184	200	209	219	221
55	199	209	219	209	239	249	269	289	279	259	269	289	337	137	146	156	165	174	183	200	209	219	221
56	198	208	218	208	238	248	268	288	278	258	268	288	336	136	145	155	164	173	182	200	209	219	221
57	197	207	217	207	237	247	267	287	277	257	267	287	335	135	144	154	163	172	181	200	209	219	221
58	196	206	216	206	236	246	266	286	276	256	266	286	334	134	143	153	162	171	180	200	209	219	221
59	195	205	215	205	235	245	265	285	275	255	265	285	333	133	142	152	161	170	179	200	209	219	221
60	194	204	214	204	234	244	264	284	274	254	264	284	332	132	141	151	160	169	178	200	209	219	221
61	193	203	213	203	233	243	263	283	273	253	263	283	331	131	140	150	159	168	177	200	209	219	221
62	192	202	212	202	232	242	262	282	272	252	262	282	330	130	139	149	158	167	176	200	209	219	221
63	191	201	211	201	231	241	261	281	271	251	261	281	329	129	138	148	157	166	175	200	209	219	221
64	190	200	210	200	230	240	260	280	270	250	260	280	328	128	137	147	156	165	174	200	209	219	221
65	189	199	209	199	229	239	259	279	269	249	259	279	327	127	136	146	155	164	173	200	209	219	221
66	188	198	208	198	228	238	258	278	268	248	258	278	326	126	135	145	154	163	172	200	209	219	221
67	187	197	207	197	227	237	257	277	267	247	257	277	325	125	134	144	153	162	171	200	209	219	221
68	186	196	206	196	226	236	256	276	266	246	256	276	324	124	133	143	152	161	170	200	209	219	221
69	185	195	205	195	225	235	255	275	265	245	255	275	323	123	132	142	151	160	169	200	209	219	221
70	184	194	204	194	224	234	254	274	264	244	254	274	322	122	131	141	150	159	168	200	209	219	221
71	183	193	203	193	223	233	253	273	263	243	253	273	321	121	130	140	149	158	167	200	209	219	221
72	182	192	202	192	222	232	252	272	262	242	252	272	320	120	129	139	148	157	166	200	209	219	221
73	181	191	201	191	221	231	251	271	261	241	251	271	319	119	128	138	147	156	165	200	209	219	221
74	180	190	200	190	220	230	250	270	260	240	250	270	318	118	127	137	146	155	164	200	209	219	221
75	179	189	199	189	219	229	249	269	259	239	249	269	317	117	126	136	145	154	163	200	209	219	221
76	178	188	198	188	218	228	248	268	258	238	248	268	316	116	125	135	144	153	162	200	209	219	221
77	177	187	197	187	217	227	247	267	257	237	247	267	315	115	124	134	143	152	161	200	209	219	221
78	176	186	196	186	216	226	246	266	256	236	246	266	314	114	123	133	142	151	160	200	209	219	221
79	175	185	195	185	215	225	245	265	255	235	245	265	313	113	122	132	141	150	159	200	209	219	221
80	174	184	194	184	214	224	244	264	254	234	244	264	312	112	121	131	140	149	158	200	209	219	221
81	173	183	193	183	213	223	243	263	253	233	243	263	311	111	120	130	139	148	157	200	209	219	221
82	172	182	192	182	212	222	242	262	252	232	242	262	310	110	119	129	138	147	156	200	209	219	221
83	171	181	191	181	211	221	241	261	251	231	241	261	309	109	118	128	137	146	155	200	209	219	221
84	170	180	190	180	210	220	240	260	250	230	240	260	308	108	117	127	136	145	154	200	209	219	221
85	169	179	189	179	209	219	239	259	249	229	239	259	307	107	116	126	135	144	153	200	209	219	221
86	168	178	188	178	208	218	238	258	248	228	238	258	306	106	115	125	134	143	152	200	209	219	221
87	167	177	187	177	207	217	237	257	247	227	237	257	305	105	114	124	133	142	151	200	209	219	221
88	166	176	186	176	206	216	236	256	246	226	236	256	304	104	113	123	132	141	150	200	209	219	221
89	165	175	185	175	205	215	235	255	245	225	235	255	303	103	112	122	131	140	149	200	209	219	221
90	164	174	184	174	204	214	234	254	244	224	234	254	302	102	111	121	130	139	148	200	209	219	221
91	163	173	183	173	203	213	233	253	243	223	233	253	301	101	110	120	129	138	147	200	209	219	221
92	162	172	182	172	202	212	232	252	242	222	232	252	300	100	109	119	128	137	146	200	209	219	221
93	161	171	181	171	201	211	231	251	241	221	231	251	299	99	108	118	127	136	145	200	209	219	221
94	160	170	180	170	200	210	230	250	240	220	230	250	298	98	107	117	126	135	144	200	209	219	221
95	159	169	179	169	199	209	229	249	239	219	229	249	297	97	106	116	125	134	143	200	209	219	221
96	158	168	178	168	198	208	228	248	238	218	228	248	296	96	105	115	124	133	142	200	209	219	221
97	157	167	177	167	197	207	227	247	237	217	227	247	295	95	104	114	123	132	141	200	209	219	221
98	156	166	176	166	196	206	226	246	236	216	226	246	294	94	103	113	122	131	140	200	209	219	221
99	155	165	175	165	195	205	225	245	235	215	225	245	293	93	102	112	121	130	139	200	209	219	221
100	154	164	174	164	194	204	224	244	234	214	224	244	292	92	101	111	120	129	138	200	209	219	221

APPENDIX C. (cont.)
 Reduction of Observed Degrees API to Degrees API at 60°F. (cont.)

Observed Temperature in °F.	Observed Degrees API										Observed Degrees API									
	30	31	32	33	34	35	36	37	38	39	30	31	32	33	34	35	36	37	38	39
0	34.2	35.3	36.4	37.4	38.4	39.4	40.7	41.8	42.9	44.0	100	97.4	94.8	92.2	89.6	87.0	84.4	81.8	79.2	76.6
1	34.0	35.1	36.2	37.2	38.3	39.3	40.6	41.7	42.8	43.9	101	98.4	95.8	93.2	90.6	88.0	85.4	82.8	80.2	77.6
2	34.0	35.1	36.2	37.2	38.3	39.4	40.5	41.6	42.7	43.8	102	99.4	96.8	94.2	91.6	89.0	86.4	83.8	81.2	78.6
3	33.9	34.9	36.0	37.1	38.2	39.2	40.3	41.4	42.5	43.6	103	100.4	97.8	95.2	92.6	90.0	87.4	84.8	82.2	79.6
4	33.8	34.8	35.9	37.0	38.1	39.1	40.2	41.3	42.4	43.5	104	101.4	98.8	96.2	93.6	91.0	88.4	85.8	83.2	80.6
5	33.7	34.8	35.9	37.0	38.1	39.1	40.2	41.2	42.3	43.3	105	102.4	99.8	97.2	94.6	92.0	89.4	86.8	84.2	81.6
6	33.7	34.7	35.8	36.8	37.9	39.0	40.1	41.1	42.2	43.3	106	103.4	100.8	98.2	95.6	93.0	90.4	87.8	85.2	82.6
7	33.6	34.7	35.8	36.8	37.8	38.9	40.0	41.1	42.1	43.2	107	104.4	101.8	99.2	96.6	94.0	91.4	88.8	86.2	83.6
8	33.5	34.6	35.7	36.7	37.8	38.9	40.0	41.0	42.1	43.1	108	105.4	102.8	100.2	97.6	95.0	92.4	89.8	87.2	84.6
9	33.4	34.5	35.6	36.6	37.7	38.8	39.8	40.9	42.0	43.1	109	106.4	103.8	101.2	98.6	96.0	93.4	90.8	88.2	85.6
10	33.4	34.5	35.6	36.6	37.7	38.8	39.8	40.9	42.0	43.1	110	107.4	104.8	102.2	99.6	97.0	94.4	91.8	89.2	86.6
11	33.3	34.4	35.4	36.5	37.5	38.6	39.7	40.7	41.8	42.9	111	108.4	105.8	103.2	100.6	98.0	95.4	92.8	90.2	87.6
12	33.3	34.4	35.4	36.4	37.5	38.5	39.6	40.6	41.7	42.8	112	109.4	106.8	104.2	101.6	99.0	96.4	93.8	91.2	88.6
13	33.2	34.3	35.3	36.4	37.4	38.5	39.5	40.6	41.6	42.7	113	110.4	107.8	105.2	102.6	100.0	97.4	94.8	92.2	89.6
14	33.1	34.2	35.3	36.3	37.4	38.5	39.5	40.6	41.6	42.7	114	111.4	108.8	106.2	103.6	101.0	98.4	95.8	93.2	90.6
15	33.1	34.1	35.2	36.2	37.3	38.4	39.4	40.5	41.6	42.6	115	112.4	109.8	107.2	104.6	102.0	99.4	96.8	94.2	91.6
16	33.0	34.1	35.1	36.2	37.2	38.3	39.3	40.4	41.5	42.5	116	113.4	110.8	108.2	105.6	103.0	100.4	97.8	95.2	92.6
17	32.9	34.0	35.0	36.1	37.1	38.2	39.2	40.3	41.4	42.4	117	114.4	111.8	109.2	106.6	104.0	101.4	98.8	96.2	93.6
18	32.9	33.9	35.0	36.0	37.1	38.2	39.2	40.3	41.3	42.4	118	115.4	112.8	110.2	107.6	105.0	102.4	99.8	97.2	94.6
19	32.8	33.8	34.9	36.0	37.0	38.1	39.1	40.2	41.2	42.3	119	116.4	113.8	111.2	108.6	106.0	103.4	100.8	98.2	95.6
20	32.7	33.8	34.8	35.9	36.9	38.0	39.0	40.1	41.2	42.2	120	117.4	114.8	112.2	109.6	107.0	104.4	101.8	99.2	96.6
21	32.6	33.7	34.7	35.8	36.8	37.9	39.0	40.0	41.1	42.1	121	118.4	115.8	113.2	110.6	108.0	105.4	102.8	100.2	97.6
22	32.5	33.6	34.6	35.7	36.7	37.8	38.9	39.9	41.0	42.1	122	119.4	116.8	114.2	111.6	109.0	106.4	103.8	101.2	98.6
23	32.4	33.5	34.5	35.6	36.6	37.7	38.7	39.8	40.8	41.9	123	120.4	117.8	115.2	112.6	110.0	107.4	104.8	102.2	99.6
24	32.4	33.5	34.5	35.6	36.6	37.7	38.7	39.8	40.8	41.9	124	121.4	118.8	116.2	113.6	111.0	108.4	105.8	103.2	100.6
25	32.4	33.4	34.5	35.5	36.5	37.6	38.6	39.6	40.7	41.7	125	122.4	119.8	117.2	114.6	112.0	109.4	106.8	104.2	101.6
26	32.3	33.4	34.4	35.4	36.5	37.5	38.5	39.5	40.6	41.6	126	123.4	120.8	118.2	115.6	113.0	110.4	107.8	105.2	102.6
27	32.2	33.3	34.3	35.3	36.4	37.4	38.5	39.5	40.6	41.6	127	124.4	121.8	119.2	116.6	114.0	111.4	108.8	106.2	103.6
28	32.1	33.2	34.2	35.2	36.3	37.3	38.4	39.4	40.5	41.5	128	125.4	122.8	120.2	117.6	115.0	112.4	109.8	107.2	104.6
29	32.1	33.1	34.2	35.2	36.3	37.3	38.4	39.4	40.4	41.5	129	126.4	123.8	121.2	118.6	116.0	113.4	110.8	108.2	105.6
30	32.0	33.0	34.1	35.1	36.1	37.2	38.2	39.2	40.3	41.3	130	127.4	124.8	122.2	119.6	117.0	114.4	111.8	109.2	106.6
31	31.9	32.9	34.0	35.0	36.0	37.1	38.1	39.1	40.1	41.1	131	128.4	125.8	123.2	120.6	118.0	115.4	112.8	110.2	107.6
32	31.9	32.9	34.0	35.0	36.0	37.1	38.1	39.1	40.1	41.1	132	129.4	126.8	124.2	121.6	119.0	116.4	113.8	111.2	108.6
33	31.8	32.8	33.9	34.9	35.9	37.0	38.0	39.0	40.0	41.0	133	130.4	127.8	125.2	122.6	120.0	117.4	114.8	112.2	109.6
34	31.7	32.8	33.8	34.8	35.8	36.9	37.9	38.9	39.9	40.9	134	131.4	128.8	126.2	123.6	121.0	118.4	115.8	113.2	110.6
35	31.7	32.7	33.7	34.8	35.8	36.8	37.9	38.9	39.9	40.9	135	132.4	129.8	127.2	124.6	122.0	119.4	116.8	114.2	111.6
36	31.7	32.7	33.7	34.8	35.8	36.8	37.9	38.9	39.9	40.9	136	133.4	130.8	128.2	125.6	123.0	120.4	117.8	115.2	112.6
37	31.6	32.6	33.6	34.7	35.7	36.7	37.8	38.8	39.9	40.9	137	134.4	131.8	129.2	126.6	124.0	121.4	118.8	116.2	113.6
38	31.5	32.5	33.5	34.6	35.6	36.6	37.6	38.6	39.6	40.6	138	135.4	132.8	130.2	127.6	125.0	122.4	119.8	117.2	114.6
39	31.4	32.4	33.4	34.5	35.5	36.5	37.5	38.5	39.5	40.5	139	136.4	133.8	131.2	128.6	126.0	123.4	120.8	118.2	115.6
40	31.3	32.3	33.4	34.4	35.4	36.4	37.4	38.4	39.4	40.4	140	137.4	134.8	132.2	129.6	127.0	124.4	121.8	119.2	116.6
41	31.3	32.3	33.3	34.3	35.3	36.3	37.3	38.3	39.3	40.3	141	138.4	135.8	133.2	130.6	128.0	125.4	122.8	120.2	117.6
42	31.2	32.2	33.2	34.2	35.2	36.2	37.2	38.2	39.2	40.2	142	139.4	136.8	134.2	131.6	129.0	126.4	123.8	121.2	118.6
43	31.1	32.1	33.1	34.1	35.1	36.1	37.1	38.1	39.1	40.1	143	140.4	137.8	135.2	132.6	130.0	127.4	124.8	122.2	119.6
44	31.0	32.0	33.0	34.0	35.0	36.0	37.0	38.0	39.0	40.0	144	141.4	138.8	136.2	133.6	131.0	128.4	125.8	123.2	120.6

PHYSICAL AND CHEMICAL PROPERTIES

APPENDIX C (cont)

Reduction of Observed Degrees APL to Degrees APL at 60°F. (cont.)

Observed Temperature in °F	Observed degrees APL										Corresponding degrees APL at 60°F									
	40	41	42	43	44	45	46	47	48	49	50	51	52	53	54	55	56	57	58	59
0	451	462	473	483	494	504	514	524	534	544	554	564	574	584	594	604	614	624	634	644
1	450	460	471	482	493	503	513	523	533	543	553	563	573	583	593	603	613	623	633	643
2	449	460	471	482	493	503	513	523	533	543	553	563	573	583	593	603	613	623	633	643
3	448	459	470	481	492	502	512	522	532	542	552	562	572	582	592	602	612	622	632	642
4	447	458	469	480	491	501	511	521	531	541	551	561	571	581	591	601	611	621	631	641
5	446	457	468	479	489	499	509	519	529	539	549	559	569	579	589	599	609	619	629	639
6	445	456	466	477	487	497	507	517	527	537	547	557	567	577	587	597	607	617	627	637
7	444	455	465	476	486	496	506	516	526	536	546	556	566	576	586	596	606	616	626	636
8	443	454	465	475	485	495	505	515	525	535	545	555	565	575	585	595	605	615	625	635
9	442	453	464	475	485	495	505	515	525	535	545	555	565	575	585	595	605	615	625	635
10	441	452	463	474	484	494	504	514	524	534	544	554	564	574	584	594	604	614	624	634
11	440	451	462	473	483	493	503	513	523	533	543	553	563	573	583	593	603	613	623	633
12	439	450	461	472	482	492	502	512	522	532	542	552	562	572	582	592	602	612	622	632
13	438	449	460	471	481	491	501	511	521	531	541	551	561	571	581	591	601	611	621	631
14	438	449	460	471	481	491	501	511	521	531	541	551	561	571	581	591	601	611	621	631
15	437	448	459	469	479	489	499	509	519	529	539	549	559	569	579	589	599	609	619	629
16	436	447	458	468	478	488	498	508	518	528	538	548	558	568	578	588	598	608	618	628
17	435	446	457	467	477	487	497	507	517	527	537	547	557	567	577	587	597	607	617	627
18	434	445	456	466	476	486	496	506	516	526	536	546	556	566	576	586	596	606	616	626
19	434	445	456	466	477	487	497	507	517	527	537	547	557	567	577	587	597	607	617	627
20	433	443	454	465	475	485	495	505	515	525	535	545	555	565	575	585	595	605	615	625
21	432	442	453	464	474	484	494	504	514	524	534	544	554	564	574	584	594	604	614	624
22	431	442	452	463	473	483	493	503	513	523	533	543	553	563	573	583	593	603	613	623
23	430	441	451	462	472	482	492	502	512	522	532	542	552	562	572	582	592	602	612	622
24	429	440	451	461	471	481	491	501	511	521	531	541	551	561	571	581	591	601	611	621
25	428	439	450	460	470	480	490	500	510	520	530	540	550	560	570	580	590	600	610	620
26	428	439	450	460	470	480	490	500	510	520	530	540	550	560	570	580	590	600	610	620
27	427	437	448	458	468	478	488	498	508	518	528	538	548	558	568	578	588	598	608	618
28	426	436	447	457	467	477	487	497	507	517	527	537	547	557	567	577	587	597	607	617
29	425	435	446	456	466	476	486	496	506	516	526	536	546	556	566	576	586	596	606	616
30	424	434	445	455	465	475	485	495	505	515	525	535	545	555	565	575	585	595	605	615
31	423	433	444	454	464	474	484	494	504	514	524	534	544	554	564	574	584	594	604	614
32	422	432	443	453	463	473	483	493	503	513	523	533	543	553	563	573	583	593	603	613
33	421	431	442	452	462	472	482	492	502	512	522	532	542	552	562	572	582	592	602	612
34	421	431	442	452	462	472	482	492	502	512	522	532	542	552	562	572	582	592	602	612
35	420	431	441	452	462	472	482	492	502	512	522	532	542	552	562	572	582	592	602	612
36	419	430	440	451	461	471	481	491	501	511	521	531	541	551	561	571	581	591	601	611
37	418	429	439	449	459	469	479	489	499	509	519	529	539	549	559	569	579	589	599	609
38	418	428	438	448	458	468	478	488	498	508	518	528	538	548	558	568	578	588	598	608
39	417	427	437	447	457	467	477	487	497	507	517	527	537	547	557	567	577	587	597	607
40	416	426	437	447	457	467	477	487	497	507	517	527	537	547	557	567	577	587	597	607
41	415	425	436	446	456	466	476	486	496	506	516	526	536	546	556	566	576	586	596	606
42	414	424	435	445	455	465	475	485	495	505	515	525	535	545	555	565	575	585	595	605
43	413	423	433	443	453	463	473	483	493	503	513	523	533	543	553	563	573	583	593	603
44	413	423	433	443	453	463	473	483	493	503	513	523	533	543	553	563	573	583	593	603
45	412	422	432	442	452	462	472	482	492	502	512	522	532	542	552	562	572	582	592	602
46	411	421	431	441	451	461	471	481	491	501	511	521	531	541	551	561	571	581	591	601
47	410	420	430	440	450	460	470	480	490	500	510	520	530	540	550	560	570	580	590	600
48	409	419	429	439	449	459	469	479	489	499	509	519	529	539	549	559	569	579	589	599
49	408	418	428	438	448	458	468	478	488	498	508	518	528	538	548	558	568	578	588	598

APPENDIX C (cont.)
Reduction of Observed Degrees API to Degrees API at 60° F. (cont.)

Observed temperature in °F	Observed degrees API										Observed degrees API										
	50	51	52	53	54	55	56	57	58	59	50	51	52	53	54	55	56	57	58	59	
0	54.3	57.5	58.6	59.7	60.8	61.9	63.1	64.2	65.3	66.4	65	40.4	50.4	51.4	52.4	53.4	54.4	55.4	56.4	57.4	58.4
1	56.2	57.4	58.5	59.6	60.7	61.8	62.9	64.0	65.2	66.3	66	40.4	50.4	51.4	52.4	53.4	54.4	55.4	56.4	57.4	58.4
2	56.0	57.1	58.2	59.3	60.4	61.5	62.6	63.7	64.8	65.9	67	40.3	50.3	51.3	52.3	53.3	54.3	55.3	56.3	57.3	58.3
3	56.0	57.1	58.2	59.3	60.4	61.5	62.6	63.7	64.8	65.9	68	40.1	50.1	51.1	52.1	53.1	54.1	55.0	56.0	57.0	58.0
4	55.7	56.9	58.1	59.2	60.3	61.4	62.5	63.6	64.8	65.9	69	40.0	50.0	51.0	52.0	53.0	54.0	54.9	55.9	56.9	57.9
5	55.6	56.8	57.9	59.0	60.1	61.2	62.3	63.4	64.5	65.6	70	40.0	50.0	51.0	52.0	53.0	54.0	54.9	55.9	56.9	57.9
6	55.5	56.6	57.7	58.8	59.9	61.0	62.2	63.3	64.4	65.5	71	40.0	50.0	51.0	52.0	53.0	54.0	54.9	55.9	56.9	57.9
7	55.3	56.4	57.5	58.6	59.7	60.8	61.9	63.0	64.1	65.2	72	40.0	50.0	51.0	52.0	53.0	54.0	54.9	55.9	56.9	57.9
8	55.3	56.4	57.5	58.6	59.7	60.8	61.9	63.0	64.1	65.2	74	40.0	50.0	51.0	52.0	53.0	54.0	54.9	55.9	56.9	57.9
9	55.2	56.3	57.4	58.5	59.6	60.7	61.8	62.9	64.0	65.1	75	40.0	50.0	51.0	52.0	53.0	54.0	54.9	55.9	56.9	57.9
10	55.1	56.2	57.3	58.4	59.5	60.6	61.7	62.8	63.9	65.0	76	40.0	50.0	51.0	52.0	53.0	54.0	54.9	55.9	56.9	57.9
11	55.0	56.1	57.2	58.3	59.4	60.5	61.6	62.7	63.8	64.9	77	40.0	50.0	51.0	52.0	53.0	54.0	54.9	55.9	56.9	57.9
12	55.0	56.1	57.2	58.3	59.4	60.5	61.6	62.7	63.8	64.9	78	40.0	50.0	51.0	52.0	53.0	54.0	54.9	55.9	56.9	57.9
13	54.9	56.0	57.1	58.2	59.3	60.4	61.5	62.6	63.7	64.8	79	40.0	50.0	51.0	52.0	53.0	54.0	54.9	55.9	56.9	57.9
14	54.8	55.9	57.0	58.1	59.2	60.3	61.4	62.5	63.6	64.7	80	40.0	50.0	51.0	52.0	53.0	54.0	54.9	55.9	56.9	57.9
15	54.8	55.9	57.0	58.1	59.2	60.3	61.4	62.5	63.6	64.7	81	40.0	50.0	51.0	52.0	53.0	54.0	54.9	55.9	56.9	57.9
16	54.7	55.8	56.9	58.0	59.1	60.2	61.3	62.4	63.5	64.6	82	40.0	50.0	51.0	52.0	53.0	54.0	54.9	55.9	56.9	57.9
17	54.7	55.8	56.9	58.0	59.1	60.2	61.3	62.4	63.5	64.6	83	40.0	50.0	51.0	52.0	53.0	54.0	54.9	55.9	56.9	57.9
18	54.6	55.7	56.8	57.9	59.0	60.1	61.2	62.3	63.4	64.5	84	40.0	50.0	51.0	52.0	53.0	54.0	54.9	55.9	56.9	57.9
19	54.6	55.7	56.8	57.9	59.0	60.1	61.2	62.3	63.4	64.5	85	40.0	50.0	51.0	52.0	53.0	54.0	54.9	55.9	56.9	57.9
20	54.5	55.6	56.7	57.8	58.9	60.0	61.1	62.2	63.3	64.4	86	40.0	50.0	51.0	52.0	53.0	54.0	54.9	55.9	56.9	57.9
21	54.5	55.6	56.7	57.8	58.9	60.0	61.1	62.2	63.3	64.4	87	40.0	50.0	51.0	52.0	53.0	54.0	54.9	55.9	56.9	57.9
22	54.5	55.6	56.7	57.8	58.9	60.0	61.1	62.2	63.3	64.4	88	40.0	50.0	51.0	52.0	53.0	54.0	54.9	55.9	56.9	57.9
23	54.5	55.6	56.7	57.8	58.9	60.0	61.1	62.2	63.3	64.4	89	40.0	50.0	51.0	52.0	53.0	54.0	54.9	55.9	56.9	57.9
24	54.5	55.6	56.7	57.8	58.9	60.0	61.1	62.2	63.3	64.4	90	40.0	50.0	51.0	52.0	53.0	54.0	54.9	55.9	56.9	57.9
25	54.5	55.6	56.7	57.8	58.9	60.0	61.1	62.2	63.3	64.4	91	40.0	50.0	51.0	52.0	53.0	54.0	54.9	55.9	56.9	57.9
26	54.5	55.6	56.7	57.8	58.9	60.0	61.1	62.2	63.3	64.4	92	40.0	50.0	51.0	52.0	53.0	54.0	54.9	55.9	56.9	57.9
27	54.5	55.6	56.7	57.8	58.9	60.0	61.1	62.2	63.3	64.4	93	40.0	50.0	51.0	52.0	53.0	54.0	54.9	55.9	56.9	57.9
28	54.5	55.6	56.7	57.8	58.9	60.0	61.1	62.2	63.3	64.4	94	40.0	50.0	51.0	52.0	53.0	54.0	54.9	55.9	56.9	57.9
29	54.5	55.6	56.7	57.8	58.9	60.0	61.1	62.2	63.3	64.4	95	40.0	50.0	51.0	52.0	53.0	54.0	54.9	55.9	56.9	57.9
30	54.5	55.6	56.7	57.8	58.9	60.0	61.1	62.2	63.3	64.4	96	40.0	50.0	51.0	52.0	53.0	54.0	54.9	55.9	56.9	57.9
31	54.5	55.6	56.7	57.8	58.9	60.0	61.1	62.2	63.3	64.4	97	40.0	50.0	51.0	52.0	53.0	54.0	54.9	55.9	56.9	57.9
32	54.5	55.6	56.7	57.8	58.9	60.0	61.1	62.2	63.3	64.4	98	40.0	50.0	51.0	52.0	53.0	54.0	54.9	55.9	56.9	57.9
33	54.5	55.6	56.7	57.8	58.9	60.0	61.1	62.2	63.3	64.4	99	40.0	50.0	51.0	52.0	53.0	54.0	54.9	55.9	56.9	57.9
34	54.5	55.6	56.7	57.8	58.9	60.0	61.1	62.2	63.3	64.4	100	40.0	50.0	51.0	52.0	53.0	54.0	54.9	55.9	56.9	57.9
35	54.5	55.6	56.7	57.8	58.9	60.0	61.1	62.2	63.3	64.4	100	40.0	50.0	51.0	52.0	53.0	54.0	54.9	55.9	56.9	57.9
36	54.5	55.6	56.7	57.8	58.9	60.0	61.1	62.2	63.3	64.4	100	40.0	50.0	51.0	52.0	53.0	54.0	54.9	55.9	56.9	57.9
37	54.5	55.6	56.7	57.8	58.9	60.0	61.1	62.2	63.3	64.4	100	40.0	50.0	51.0	52.0	53.0	54.0	54.9	55.9	56.9	57.9
38	54.5	55.6	56.7	57.8	58.9	60.0	61.1	62.2	63.3	64.4	100	40.0	50.0	51.0	52.0	53.0	54.0	54.9	55.9	56.9	57.9
39	54.5	55.6	56.7	57.8	58.9	60.0	61.1	62.2	63.3	64.4	100	40.0	50.0	51.0	52.0	53.0	54.0	54.9	55.9	56.9	57.9
40	54.5	55.6	56.7	57.8	58.9	60.0	61.1	62.2	63.3	64.4	100	40.0	50.0	51.0	52.0	53.0	54.0	54.9	55.9	56.9	57.9
41	54.5	55.6	56.7	57.8	58.9	60.0	61.1	62.2	63.3	64.4	100	40.0	50.0	51.0	52.0	53.0	54.0	54.9	55.9	56.9	57.9
42	54.5	55.6	56.7	57.8	58.9	60.0	61.1	62.2	63.3	64.4	100	40.0	50.0	51.0	52.0	53.0	54.0	54.9	55.9	56.9	57.9
43	54.5	55.6	56.7	57.8	58.9	60.0	61.1	62.2	63.3	64.4	100	40.0	50.0	51.0	52.0	53.0	54.0	54.9	55.9	56.9	57.9
44	54.5	55.6	56.7	57.8	58.9	60.0	61.1	62.2	63.3	64.4	100	40.0	50.0	51.0	52.0	53.0	54.0	54.9	55.9	56.9	57.9

APPENDIX C (cont)
Reduction of Observed Degrees API to Degrees API at 60° F. (cont.)

Observed Temperature in °F.	Observed degrees API										Observed Temperature in °F.	Corresponding degrees API at 60° F.									
	50	61	62	63	64	65	66	67	68	69		60	61	62	63	64	65	66	67	68	69
0	674	681	687	693	700	712	743	753	766	777	65	59	604	614	624	634	644	654	664	673	683
1	673	680	686	692	700	712	743	753	766	777	66	59	604	614	624	634	644	654	664	673	682
2	673	684	695	706	717	729	740	752	765	774	66	59	602	602	612	622	631	641	650	659	668
3	671	682	694	705	716	727	738	750	761	773	68	59	601	610	620	630	640	650	660	669	678
4	670	681	692	704	715	726	737	749	760	771	68	59	600	609	619	629	639	649	659	668	678
5	669	680	691	702	713	724	735	747	758	770	70	59	598	598	608	618	628	638	647	657	677
6	668	677	688	700	712	723	734	746	757	768	71	58	597	597	607	617	626	636	645	655	676
7	666	675	686	700	712	723	734	746	757	768	71	58	595	604	614	624	634	644	654	664	674
8	665	676	687	698	709	720	731	743	754	765	71	58	595	604	614	624	634	644	654	664	674
9	663	674	686	697	708	719	731	743	754	765	74	58	594	603	613	623	633	643	653	663	672
10	662	673	684	695	706	717	728	740	751	762	75	58	593	593	602	612	622	631	641	651	660
11	660	672	683	694	705	716	727	738	749	760	76	58	592	592	601	611	620	630	640	650	659
12	659	670	681	692	703	714	725	736	747	758	77	58	591	590	600	610	619	629	639	648	658
13	658	669	680	691	702	713	724	735	746	757	77	58	590	589	600	610	619	629	639	648	658
14	657	668	679	690	701	712	723	734	745	756	79	57	589	588	598	608	617	627	637	646	656
15	655	666	677	688	699	710	721	732	743	754	80	57	587	587	597	606	615	624	633	642	651
16	654	665	676	687	698	709	720	731	742	753	81	57	586	586	596	605	614	623	632	641	650
17	653	664	675	686	697	708	719	730	741	751	82	57	585	585	594	604	614	623	633	642	652
18	652	663	674	685	696	707	718	729	740	751	82	57	585	585	594	604	614	623	633	642	652
19	650	661	672	683	694	705	715	726	737	748	84	57	583	583	592	602	611	621	630	640	650
20	649	660	671	682	692	702	714	724	736	747	85	57	582	582	591	600	610	619	629	639	648
21	648	658	669	680	691	702	714	724	736	747	85	57	581	581	590	600	610	619	629	639	648
22	648	657	668	679	690	700	711	722	733	744	87	56	579	579	589	598	608	617	627	636	645
23	647	656	667	677	688	699	710	721	731	742	88	56	579	578	587	597	606	616	625	635	644
24	644	654	665	676	687	698	708	719	730	741	89	56	578	577	586	596	605	615	624	634	643
25	642	653	664	675	685	696	707	718	728	739	90	56	577	576	585	595	604	614	623	632	642
26	641	651	661	672	683	694	705	715	725	735	91	56	576	575	584	594	603	612	622	631	640
27	640	650	660	671	681	692	703	713	724	735	91	56	576	575	584	594	603	612	622	631	640
28	639	649	659	669	679	689	699	709	719	729	93	56	574	573	582	591	601	610	619	629	638
29	637	648	658	668	678	688	698	708	718	728	94	56	572	572	581	590	599	609	618	628	637
30	636	647	657	667	677	687	697	707	717	727	95	56	571	570	580	589	598	608	617	626	635
31	635	645	656	666	676	686	696	706	716	726	96	56	570	570	579	588	597	606	615	625	634
32	634	644	654	664	674	684	694	704	714	724	96	56	570	570	579	588	597	606	615	625	634
33	633	643	653	663	673	683	693	703	713	723	97	56	569	569	578	587	596	605	614	624	633
34	632	642	652	662	672	682	692	702	712	722	99	55	567	567	576	585	594	603	612	621	630
35	630	640	650	660	670	680	690	700	710	720	100	55	567	567	576	585	594	603	612	621	630
36	629	639	649	659	669	679	689	699	709	719	100	55	566	566	575	584	593	602	611	620	629
37	628	638	648	658	668	678	688	698	708	718	100	55	566	566	575	584	593	602	611	620	629
38	628	638	648	658	668	678	688	698	708	718	100	55	566	566	575	584	593	602	611	620	629
39	625	635	645	655	665	675	685	695	705	715	104	55	562	562	571	580	589	598	607	616	625
40	624	634	644	654	664	674	684	694	704	714	104	55	561	561	570	579	588	597	606	615	624
41	623	633	643	653	663	673	683	693	703	713	104	55	561	561	570	579	588	597	606	615	624
42	621	631	641	651	661	671	681	691	701	711	102	55	560	560	569	578	587	596	605	614	623
43	621	631	641	651	661	671	681	691	701	711	102	55	560	560	569	578	587	596	605	614	623
44	619	629	639	649	659	669	679	689	699	709	104	55	559	559	568	577	586	595	604	613	622
45	619	629	639	649	659	669	679	689	699	709	104	55	559	559	568	577	586	595	604	613	622
46	619	629	639	649	659	669	679	689	699	709	104	55	559	559	568	577	586	595	604	613	622
47	619	629	639	649	659	669	679	689	699	709	104	55	559	559	568	577	586	595	604	613	622
48	619	629	639	649	659	669	679	689	699	709	104	55	559	559	568	577	586	595	604	613	622
49	619	629	639	649	659	669	679	689	699	709	104	55	559	559	568	577	586	595	604	613	622
50	619	629	639	649	659	669	679	689	699	709	104	55	559	559	568	577	586	595	604	613	622
51	619	629	639	649	659	669	679	689	699	709	104	55	559	559	568	577	586	595	604	613	622
52	619	629	639	649	659	669	679	689	699	709	104	55	559	559	568	577	586	595	604	613	622
53	619	629	639	649	659	669	679	689	699	709	104	55	559	559	568	577	586	595	604	613	622
54	619	629	639	649	659	669	679	689	699	709	104	55	559	559	568	577	586	595	604	613	622
55	619	629	639	649	659	669	679	689	699	709	104	55	559	559	568	577	586	595	604	613	622
56	619	629	639	649	659	669	679	689	699	709	104	55	559	559	568	577	586	595	604	613	622
57	619	629	639	649	659	669	679	689	699	709	104	55	559	559	568	577	586	595	604	613	622
58	619	629	639	649	659	669	679	689	699	709	104	55	559	559	568	577	586	595	604	613	622
59	619	629	639	649	659	669	679	689	699	709	104	55	559	559	568	577	586	595	604	613	622
60	619	629	639	649	659	669	679	689	699	709	104	55	559	559	568	577	586	595	604	613	622

APPENDIX C (cont.)

Reduction of Observed Degrees API. to Degrees API. at 60° F. (cont.)

Observed temperature in ° F	Observed degrees API										Observed degrees API										
	Corresponding degrees API at 60° F										Corresponding degrees API at 60° F										
	70	71	72	73	74	75	76	77	78	79	70	71	72	73	74	75	76	77	78	79	
0	788	800	812	823	834	846	857	869	881	892	721	731	742	752	762	772	781	791	801	814	
1	778	798	810	821	834	844	856	867	879	890	46	719	729	740	750	760	771	781	791	802	812
2	768	787	800	811	823	834	844	856	867	878	47	718	728	737	747	757	767	777	787	797	811
3	764	783	805	816	827	839	850	862	873	885	48	715	725	736	746	756	766	777	787	797	807
4	762	781	803	814	825	836	847	858	869	880	49	715	725	735	745	755	765	775	785	795	806
5	761	780	802	813	824	835	847	858	869	881	50	714	724	734	745	755	765	775	784	794	804
6	760	779	800	811	822	834	845	857	868	880	51	714	723	733	743	753	763	774	784	794	804
7	759	778	800	811	822	834	845	857	868	880	52	714	723	733	743	753	763	773	783	793	803
8	758	777	800	811	822	834	845	857	868	880	53	714	723	733	743	753	763	773	783	793	803
9	757	777	800	811	822	834	845	857	868	880	54	714	723	733	743	753	763	773	783	793	803
10	757	777	800	811	822	834	845	857	868	880	55	714	723	733	743	753	763	773	783	793	803
11	757	777	800	811	822	834	845	857	868	880	56	714	723	733	743	753	763	773	783	793	803
12	757	777	800	811	822	834	845	857	868	880	57	714	723	733	743	753	763	773	783	793	803
13	757	777	800	811	822	834	845	857	868	880	58	714	723	733	743	753	763	773	783	793	803
14	757	777	800	811	822	834	845	857	868	880	59	714	723	733	743	753	763	773	783	793	803
15	756	776	798	809	820	831	842	853	864	875	60	710	710	720	730	740	750	760	770	780	790
16	755	775	797	808	819	830	841	852	863	874	61	698	708	718	728	738	748	758	768	778	788
17	754	774	796	807	818	829	840	851	862	873	62	698	708	718	727	737	747	757	767	777	787
18	753	773	795	806	817	828	839	850	861	872	63	698	708	718	727	737	747	757	767	777	787
19	752	772	794	805	816	827	838	849	860	871	64	695	705	715	726	736	746	756	766	776	786
20	751	771	793	804	815	826	837	848	859	870	65	693	703	713	723	733	743	753	763	773	783
21	750	770	792	803	814	825	836	847	858	869	66	692	702	712	722	732	742	752	762	772	782
22	749	769	791	802	813	824	835	846	857	868	67	692	702	712	722	732	742	752	762	772	782
23	748	768	790	801	812	823	834	845	856	867	68	692	702	712	722	732	742	752	762	772	782
24	747	767	789	800	811	822	833	844	855	866	69	688	698	708	718	728	738	748	758	768	778
25	746	766	788	799	810	821	832	843	854	865	70	686	696	706	716	726	736	746	756	766	776
26	745	765	787	798	809	820	831	842	853	864	71	685	695	705	715	725	735	745	755	765	775
27	744	764	786	797	808	819	830	841	852	863	72	684	694	704	714	724	734	744	754	764	774
28	743	763	785	796	807	818	829	840	851	862	73	684	694	704	714	724	734	744	754	764	774
29	742	762	784	795	806	817	828	839	850	861	74	681	691	701	711	721	731	741	751	761	771
30	741	761	783	794	805	816	827	838	849	860	75	681	691	701	711	721	731	741	751	761	771
31	741	761	783	794	805	816	827	838	849	860	76	681	691	701	711	721	731	741	751	761	771
32	741	761	783	794	805	816	827	838	849	860	77	677	687	697	707	717	727	737	747	757	767
33	741	761	783	794	805	816	827	838	849	860	78	677	687	697	707	717	727	737	747	757	767
34	741	761	783	794	805	816	827	838	849	860	79	676	686	696	706	716	726	736	746	756	766
35	741	761	783	794	805	816	827	838	849	860	80	676	686	696	706	716	726	736	746	756	766
36	741	761	783	794	805	816	827	838	849	860	81	676	686	696	706	716	726	736	746	756	766
37	741	761	783	794	805	816	827	838	849	860	82	676	686	696	706	716	726	736	746	756	766
38	741	761	783	794	805	816	827	838	849	860	83	676	686	696	706	716	726	736	746	756	766
39	741	761	783	794	805	816	827	838	849	860	84	676	686	696	706	716	726	736	746	756	766
40	741	761	783	794	805	816	827	838	849	860	85	667	677	687	697	707	717	727	737	747	757
41	741	761	783	794	805	816	827	838	849	860	86	666	676	686	696	706	716	726	736	746	756
42	741	761	783	794	805	816	827	838	849	860	87	666	676	686	696	706	716	726	736	746	756
43	741	761	783	794	805	816	827	838	849	860	88	663	673	683	693	703	713	723	733	743	753
44	741	761	783	794	805	816	827	838	849	860	89	663	673	683	693	703	713	723	733	743	753
45	741	761	783	794	805	816	827	838	849	860	90	661	671	681	691	701	711	721	731	741	751

APPENDIX C (cont)
Reduction of Observed Degrees API to Degrees API at 60° F. (cont)

Observed temperature in °F.	Observed degrees API										Observed degrees API at 60° F.									
	80	81	82	83	84	85	86	87	88	89	80	81	82	83	84	85	86	87	88	89
0	80.4	91.6	92.7	93.9	95.1	96.3	97.5	98.7	99.9	101.1	80.4	82.4	83.4	84.5	85.5	86.6	87.6	88.6	89.7	90.7
1	80.5	91.7	92.8	94.0	95.2	96.4	97.6	98.8	100.0	101.2	80.5	82.5	83.5	84.6	85.6	86.7	87.7	88.7	89.7	90.7
2	80.6	91.8	92.9	94.1	95.3	96.5	97.7	98.9	100.1	101.3	80.6	82.6	83.6	84.7	85.7	86.8	87.8	88.8	89.8	90.8
3	80.7	91.9	93.0	94.2	95.4	96.6	97.8	99.0	100.2	101.4	80.7	82.7	83.7	84.8	85.8	86.9	87.9	88.9	89.9	90.9
4	80.8	92.0	93.1	94.3	95.5	96.7	97.9	99.1	100.3	101.5	80.8	82.8	83.8	84.9	85.9	87.0	88.0	89.0	90.0	91.0
5	80.9	92.1	93.2	94.4	95.6	96.8	98.0	99.2	100.4	101.6	80.9	82.9	83.9	85.0	86.0	87.1	88.1	89.1	90.1	91.1
6	81.0	92.2	93.3	94.5	95.7	96.9	98.1	99.3	100.5	101.7	81.0	83.0	84.0	85.1	86.1	87.2	88.2	89.2	90.2	91.2
7	81.1	92.3	93.4	94.6	95.8	97.0	98.2	99.4	100.6	101.8	81.1	83.1	84.1	85.2	86.2	87.3	88.3	89.3	90.3	91.3
8	81.2	92.4	93.5	94.7	95.9	97.1	98.3	99.5	100.7	101.9	81.2	83.2	84.2	85.3	86.3	87.4	88.4	89.4	90.4	91.4
9	81.3	92.5	93.6	94.8	96.0	97.2	98.4	99.6	100.8	102.0	81.3	83.3	84.3	85.4	86.4	87.5	88.5	89.5	90.5	91.5
10	81.4	92.6	93.7	94.9	96.1	97.3	98.5	99.7	100.9	102.1	81.4	83.4	84.4	85.5	86.5	87.6	88.6	89.6	90.6	91.6
11	81.5	92.7	93.8	95.0	96.2	97.4	98.6	99.8	101.0	102.2	81.5	83.5	84.5	85.6	86.6	87.7	88.7	89.7	90.7	91.7
12	81.6	92.8	93.9	95.1	96.3	97.5	98.7	99.9	101.1	102.3	81.6	83.6	84.6	85.7	86.7	87.8	88.8	89.8	90.8	91.8
13	81.7	92.9	94.0	95.2	96.4	97.6	98.8	100.0	101.2	102.4	81.7	83.7	84.7	85.8	86.8	87.9	88.9	89.9	90.9	91.9
14	81.8	93.0	94.1	95.3	96.5	97.7	98.9	100.1	101.3	102.5	81.8	83.8	84.8	85.9	86.9	88.0	89.0	90.0	91.0	92.0
15	81.9	93.1	94.2	95.4	96.6	97.8	99.0	100.2	101.4	102.6	81.9	83.9	84.9	86.0	87.0	88.1	89.1	90.1	91.1	92.1
16	82.0	93.2	94.3	95.5	96.7	97.9	99.1	100.3	101.5	102.7	82.0	84.0	85.0	86.1	87.1	88.2	89.2	90.2	91.2	92.2
17	82.1	93.3	94.4	95.6	96.8	98.0	99.2	100.4	101.6	102.8	82.1	84.1	85.1	86.2	87.2	88.3	89.3	90.3	91.3	92.3
18	82.2	93.4	94.5	95.7	96.9	98.1	99.3	100.5	101.7	102.9	82.2	84.2	85.2	86.3	87.3	88.4	89.4	90.4	91.4	92.4
19	82.3	93.5	94.6	95.8	97.0	98.2	99.4	100.6	101.8	103.0	82.3	84.3	85.3	86.4	87.4	88.5	89.5	90.5	91.5	92.5
20	82.4	93.6	94.7	95.9	97.1	98.3	99.5	100.7	101.9	103.1	82.4	84.4	85.4	86.5	87.5	88.6	89.6	90.6	91.6	92.6
21	82.5	93.7	94.8	96.0	97.2	98.4	99.6	100.8	102.0	103.2	82.5	84.5	85.5	86.6	87.6	88.7	89.7	90.7	91.7	92.7
22	82.6	93.8	94.9	96.1	97.3	98.5	99.7	100.9	102.1	103.3	82.6	84.6	85.6	86.7	87.7	88.8	89.8	90.8	91.8	92.8
23	82.7	93.9	95.0	96.2	97.4	98.6	99.8	101.0	102.2	103.4	82.7	84.7	85.7	86.8	87.8	88.9	89.9	90.9	91.9	92.9
24	82.8	94.0	95.1	96.3	97.5	98.7	99.9	101.1	102.3	103.5	82.8	84.8	85.8	86.9	87.9	89.0	90.0	91.0	92.0	93.0
25	82.9	94.1	95.2	96.4	97.6	98.8	100.0	101.2	102.4	103.6	82.9	84.9	85.9	87.0	88.0	89.1	90.1	91.1	92.1	93.1
26	83.0	94.2	95.3	96.5	97.7	98.9	100.1	101.3	102.5	103.7	83.0	85.0	86.0	87.1	88.1	89.2	90.2	91.2	92.2	93.2
27	83.1	94.3	95.4	96.6	97.8	99.0	100.2	101.4	102.6	103.8	83.1	85.1	86.1	87.2	88.2	89.3	90.3	91.3	92.3	93.3
28	83.2	94.4	95.5	96.7	97.9	99.1	100.3	101.5	102.7	103.9	83.2	85.2	86.2	87.3	88.3	89.4	90.4	91.4	92.4	93.4
29	83.3	94.5	95.6	96.8	98.0	99.2	100.4	101.6	102.8	104.0	83.3	85.3	86.3	87.4	88.4	89.5	90.5	91.5	92.5	93.5
30	83.4	94.6	95.7	96.9	98.1	99.3	100.5	101.7	102.9	104.1	83.4	85.4	86.4	87.5	88.5	89.6	90.6	91.6	92.6	93.6
31	83.5	94.7	95.8	97.0	98.2	99.4	100.6	101.8	103.0	104.2	83.5	85.5	86.5	87.6	88.6	89.7	90.7	91.7	92.7	93.7
32	83.6	94.8	95.9	97.1	98.3	99.5	100.7	101.9	103.1	104.3	83.6	85.6	86.6	87.7	88.7	89.8	90.8	91.8	92.8	93.8
33	83.7	94.9	96.0	97.2	98.4	99.6	100.8	102.0	103.2	104.4	83.7	85.7	86.7	87.8	88.8	89.9	90.9	91.9	92.9	93.9
34	83.8	95.0	96.1	97.3	98.5	99.7	100.9	102.1	103.3	104.5	83.8	85.8	86.8	87.9	88.9	90.0	91.0	92.0	93.0	94.0
35	83.9	95.1	96.2	97.4	98.6	99.8	101.0	102.2	103.4	104.6	83.9	85.9	86.9	88.0	89.0	90.1	91.1	92.1	93.1	94.1
36	84.0	95.2	96.3	97.5	98.7	99.9	101.1	102.3	103.5	104.7	84.0	86.0	87.0	88.1	89.1	90.2	91.2	92.2	93.2	94.2
37	84.1	95.3	96.4	97.6	98.8	100.0	101.2	102.4	103.6	104.8	84.1	86.1	87.1	88.2	89.2	90.3	91.3	92.3	93.3	94.3
38	84.2	95.4	96.5	97.7	98.9	100.1	101.3	102.5	103.7	104.9	84.2	86.2	87.2	88.3	89.3	90.4	91.4	92.4	93.4	94.4
39	84.3	95.5	96.6	97.8	99.0	100.2	101.4	102.6	103.8	105.0	84.3	86.3	87.3	88.4	89.4	90.5	91.5	92.5	93.5	94.5
40	84.4	95.6	96.7	97.9	99.1	100.3	101.5	102.7	103.9	105.1	84.4	86.4	87.4	88.5	89.5	90.6	91.6	92.6	93.6	94.6
41	84.5	95.7	96.8	98.0	99.2	100.4	101.6	102.8	104.0	105.2	84.5	86.5	87.5	88.6	89.6	90.7	91.7	92.7	93.7	94.7
42	84.6	95.8	96.9	98.1	99.3	100.5	101.7	102.9	104.1	105.3	84.6	86.6	87.6	88.7	89.7	90.8	91.8	92.8	93.8	94.8
43	84.7	95.9	97.0	98.2	99.4	100.6	101.8	103.0	104.2	105.4	84.7	86.7	87.7	88.8	89.8	90.9	91.9	92.9	93.9	94.9
44	84.8	96.0	97.1	98.3	99.5	100.7	101.9	103.1	104.3	105.5	84.8	86.8	87.8	88.9	89.9	91.0	92.0	93.0	94.0	95.0

PHYSICAL AND CHEMICAL PROPERTIES

APPENDIX C (cont)
Reduction of Observed Degrees API, to Degrees API, at 60° F (cont)

Observed temperature in ° F	Observed degrees API										Observed degrees API										
	90	91	92	93	94	95	96	97	98	99	90	91	92	93	94	95	96	97	98	99	
0	102.1	103.5	104.7	105.9	107.1	108.3	109.5	110.7	111.9	113.1	45	52.8	53.9	54.9	55.9	57.0	58.0	59.1	100.1	101.2	102.2
1	102.9	104.0	104.5	105.7	106.8	107.9	109.0	110.1	111.2	112.3	46	52.6	53.5	54.5	55.5	56.6	57.6	58.6	99.9	101.0	102.0
2	101.9	103.0	104.2	105.4	106.6	107.8	109.0	110.2	111.4	112.6	47	52.4	53.3	54.3	55.3	56.4	57.4	58.5	99.5	100.5	101.5
3	101.4	102.6	103.8	105.0	106.2	107.4	108.6	109.8	111.0	112.2	48	52.2	53.1	54.1	55.1	56.2	57.2	58.2	99.3	100.3	101.3
4	101.4	102.6	103.8	105.0	106.2	107.4	108.6	109.8	111.0	112.2	49	52.0	52.9	53.9	54.9	56.0	57.0	58.0	99.0	100.1	101.1
5	101.0	102.1	103.3	104.5	105.7	106.9	108.1	109.3	110.5	111.8	50	51.9	52.9	53.9	54.9	56.0	57.0	58.0	98.8	99.9	100.9
6	100.7	101.9	103.1	104.2	105.4	106.6	107.8	109.0	110.1	111.3	51	51.7	52.7	53.7	54.8	55.8	56.8	57.8	98.6	99.7	100.7
7	100.7	101.9	103.1	104.2	105.4	106.6	107.8	109.0	110.1	111.3	52	51.5	52.5	53.5	54.5	55.6	56.6	57.6	98.4	99.5	100.5
8	100.5	101.4	102.6	103.8	104.9	106.1	107.3	108.4	109.6	110.8	53	51.3	52.3	53.4	54.4	55.4	56.4	57.4	98.2	99.3	100.3
9	100.5	101.4	102.6	103.8	104.9	106.1	107.3	108.4	109.6	110.8	54	51.1	52.1	53.2	54.2	55.2	56.2	57.2	98.0	99.1	100.1
10	100.0	101.2	102.4	103.6	104.7	105.9	107.0	108.2	109.4	110.5	55	50.9	51.9	53.0	54.0	55.0	56.0	57.0	97.8	98.8	99.8
11	99.7	100.9	102.0	103.2	104.3	105.4	106.5	107.6	108.7	109.8	56	50.7	51.7	52.8	53.8	54.8	55.8	56.8	97.6	98.6	99.6
12	99.4	100.5	101.7	102.8	104.0	105.2	106.3	107.5	108.6	109.8	57	50.5	51.5	52.6	53.6	54.6	55.6	56.6	97.4	98.4	99.4
13	99.4	100.5	101.7	102.8	104.0	105.2	106.3	107.5	108.6	109.8	58	50.3	51.3	52.4	53.4	54.4	55.4	56.4	97.2	98.2	99.2
14	99.2	100.3	101.5	102.6	103.7	104.9	106.1	107.2	108.4	109.6	59	50.2	51.2	52.2	53.2	54.2	55.2	56.2	97.0	98.0	99.0
15	99.0	100.1	101.3	102.4	103.5	104.7	105.8	107.0	108.1	109.3	60	50.0	51.0	52.0	53.0	54.0	55.0	56.0	96.8	97.8	98.8
16	98.7	99.9	101.0	102.2	103.3	104.5	105.6	106.8	107.9	109.0	61	49.8	50.8	51.8	52.8	53.8	54.8	55.8	96.6	97.6	98.6
17	98.7	99.9	101.0	102.2	103.3	104.5	105.6	106.8	107.9	109.0	62	49.7	50.6	51.6	52.6	53.6	54.6	55.6	96.5	97.5	98.5
18	98.3	99.4	100.6	101.7	102.8	104.0	105.2	106.3	107.4	108.5	63	49.5	50.5	51.5	52.5	53.5	54.5	55.5	96.4	97.4	98.4
19	98.1	99.2	100.4	101.5	102.6	103.7	104.8	105.9	107.0	108.1	64	49.3	50.3	51.3	52.3	53.3	54.3	55.3	96.2	97.2	98.2
20	97.9	99.0	100.1	101.2	102.3	103.5	104.6	105.7	106.8	107.9	65	49.1	50.1	51.1	52.1	53.1	54.1	55.1	96.0	97.0	98.0
21	97.7	98.8	99.9	101.0	102.1	103.3	104.4	105.5	106.6	107.8	66	48.9	49.9	50.9	51.9	52.9	53.9	54.9	95.8	96.8	97.8
22	97.5	98.6	99.7	100.8	101.9	103.1	104.2	105.3	106.4	107.5	67	48.7	49.7	50.7	51.7	52.7	53.7	54.7	95.6	96.6	97.6
23	97.2	98.3	99.4	100.5	101.6	102.8	103.9	105.0	106.1	107.2	68	48.6	49.6	50.6	51.6	52.6	53.6	54.6	95.5	96.5	97.5
24	97.0	98.1	99.3	100.4	101.5	102.6	103.7	104.8	105.9	107.0	69	48.4	49.4	50.5	51.5	52.5	53.5	54.5	95.4	96.4	97.4
25	96.8	97.9	99.1	100.2	101.3	102.4	103.5	104.6	105.7	106.8	70	48.2	49.2	50.2	51.2	52.2	53.2	54.2	95.2	96.2	97.2
26	96.6	97.7	98.9	99.9	101.0	102.2	103.3	104.4	105.5	106.6	71	48.1	49.1	50.1	51.1	52.1	53.1	54.1	95.0	96.0	97.0
27	96.4	97.5	98.6	99.7	100.8	101.9	103.0	104.1	105.2	106.3	72	47.9	48.9	49.9	50.9	51.9	52.9	53.9	94.8	95.8	96.8
28	96.2	97.3	98.4	99.5	100.6	101.7	102.8	103.9	105.0	106.1	73	47.7	48.7	49.7	50.7	51.7	52.7	53.7	94.6	95.6	96.6
29	96.0	97.1	98.2	99.3	100.4	101.5	102.6	103.7	104.8	105.9	74	47.5	48.5	49.5	50.5	51.5	52.5	53.5	94.4	95.4	96.4
30	95.8	96.9	98.0	99.1	100.2	101.3	102.4	103.5	104.6	105.6	75	47.3	48.3	49.3	50.3	51.3	52.3	53.3	94.2	95.2	96.2
31	95.6	96.7	97.8	98.9	100.0	101.1	102.2	103.3	104.4	105.5	76	47.2	48.2	49.2	50.2	51.2	52.2	53.2	94.0	95.0	96.0
32	95.4	96.5	97.6	98.6	99.7	100.8	101.9	103.0	104.1	105.2	77	47.0	48.0	49.0	50.0	51.0	52.0	53.0	93.8	94.8	95.8
33	95.2	96.3	97.4	98.4	99.5	100.6	101.7	102.8	103.9	105.0	78	46.8	47.8	48.8	49.8	50.8	51.8	52.8	93.6	94.6	95.6
34	95.0	96.1	97.2	98.2	99.3	100.4	101.5	102.5	103.6	104.7	79	46.6	47.6	48.6	49.6	50.6	51.6	52.6	93.4	94.4	95.4
35	94.8	95.9	97.0	98.0	99.1	100.2	101.3	102.3	103.4	104.5	80	46.5	47.5	48.5	49.5	50.5	51.5	52.5	93.2	94.2	95.2
36	94.6	95.7	96.8	97.8	98.9	100.0	101.0	102.1	103.2	104.3	81	46.3	47.3	48.3	49.3	50.3	51.3	52.3	93.0	94.0	95.0
37	94.4	95.5	96.6	97.6	98.6	99.7	100.8	101.9	103.0	104.1	82	46.1	47.1	48.1	49.1	50.1	51.1	52.1	92.8	93.8	94.8
38	94.2	95.3	96.4	97.4	98.5	99.6	100.6	101.7	102.8	103.9	83	46.0	47.0	48.0	49.0	50.0	51.0	52.0	92.6	93.6	94.6
39	94.0	95.1	96.1	97.2	98.2	99.3	100.4	101.4	102.5	103.6	84	45.8	46.8	47.8	48.8	49.8	50.8	51.8	92.4	93.4	94.4
40	93.8	94.9	95.9	97.0	98.0	99.1	100.2	101.2	102.3	103.4	85	45.6	46.6	47.6	48.6	49.6	50.6	51.6	92.2	93.2	94.2
41	93.6	94.7	95.7	96.8	97.8	98.9	100.0	101.0	102.1	103.2	86	45.5	46.5	47.5	48.5	49.5	50.5	51.5	92.0	93.0	94.0
42	93.4	94.5	95.5	96.6	97.6	98.6	99.7	100.8	101.8	102.9	87	45.3	46.3	47.3	48.3	49.3	50.3	51.3	91.8	92.8	93.8
43	93.2	94.3	95.3	96.4	97.4	98.4	99.5	100.5	101.6	102.7	88	45.1	46.1	47.1	48.1	49.1	50.1	51.1	91.6	92.6	93.6
44	93.0	94.1	95.1	96.2	97.2	98.2	99.3	100.3	101.4	102.5	89	44.9	45.9	46.9	47.9	48.9	49.9	50.9	91.4	92.4	93.4
90	44.8	45.7	46.6	47.5	48.5	49.4	50.3	51.2	52.2	53.1	90	44.8	45.7	46.6	47.5	48.5	49.4	50.3	91.2	92.2	93.1

APPENDIX D

DENSITY OF PURE WATER FREE FROM
AIR AT 760 mm.*(Smithsonian Physical Tables, 1934)*

<i>Temp., ° C</i>	<i>Density of water, g per ml</i>
0	0 999 8681
1	9267
2	9679
3	9922
4	1 000 0000
5	0 999 9919
6	9682
7	9296
8	8764
9	8091
10	7282
11	6331
12	5248
13	4040
14	2712
15	1266
15 56	0443
16	0 998 9705
17	8029
18	6244
19	4347
20	2343
21	0233
22	0 997 8019
23	5703
24	3286
25	0770
26	0 996 8158
27	5451
28	2652
29	0 995 9761
30	6780

GENERAL RELATIONSHIP OF DENSITY, REFRACTIVE INDEX, AND RELATED CHARACTERISTICS, WITH STRUCTURE OF HYDROCARBONS

By A. L. WARD, *Manager, The Chemical Laboratories, The United Gas Improvement Company, S. S. KURTZ, Jr., Development Engineer, The Sun Oil Company, and W. H. FULWEILER, Consulting Chemical Engineer*

1. Molecular Volume.

THE early work on the volume relationship of compounds was largely devoted to a study of the additive properties of the elements Kopp [17, 1889], Le Bas [19, 1915], and others studied molecular volume (molecular weight—density) of liquids taken at the boiling-point or at the melting-point, in an attempt to obtain additive volumes Richards [24, 1904] pointed out that so many variables affect the atomic volume that neither the boiling-point nor the melting-point can be depended on to make the molecular volume become a precisely additive quantity Richards began a new approach to the problem of atomic volume from the point of view of the compressibility of atoms [25, 1911] He stated 'Molecules with high cohesive affinity (those hard to volatilize) should be much compressed and possess small volume, whereas molecules with slight cohesive affinity should be more bulky'

Richards and his predecessors were hampered by a lack of accurate physical data on hydrocarbons Now that a relatively large amount of accurate data is available, it is hoped that the subject of molecular volumes will again receive the attention it deserves

Some of the generalizations regarding molecular volume are of current interest because they help to fix in mind the rough relationship between the densities of the hydrocarbon series The relations here discussed are based on densities at 20° C

The molecular volume is influenced by the degree of unsaturation, and the greater the unsaturation the smaller is the molecular volume The volume change, however, decreases with an increasing number of double linkages The contraction in molecular volume that accompanies ring formation is larger than that caused by unsaturation

Table I shows in a general way the relationship in molecular volume for the members of the different hydrocarbon series having six atoms Although these data were not determined at the boiling-point, the general trend of the effect is clearly shown

TABLE I
Molecular Volume of Hydrocarbons

Formula	Compound	Molecular volume at 20° C
C ₆ H ₁₄	Hexane (n-)	130.3
C ₆ H ₁₂	Hexylene (1)	124.8
C ₆ H ₁₀	Hexadiene (1, 5)	119.0
C ₆ H ₁₀	Hexadiene (1, 3)	115.6
C ₆ H ₈	Hexatriene (1, 3, 5)	108.6
C ₆ H ₁₀	Cyclohexane	107.8
C ₆ H ₈	Cyclohexene	101.3
C ₆ H ₆	Cyclohexadiene (1, 3)	95.2
C ₆ H ₆	Benzene	88.7

2. Density and Refractive Index of Hydrocarbons.

General. In addition to the work on molecular volume, a large amount of effort was spent on the effect of com-

position on specific refractivity Until recently, however, relatively little emphasis was placed on the fascinating study of the effect of structure on density and refractive index, and the relation of these properties to boiling-point, &c

Within the scope of the present section little more than a brief glimpse of the subject can be given

Figs 1 and 2 (published with permission of The Atlantic Refining Company) give a general idea of the relation between boiling-point and density If the corresponding diagrams are drawn for refractive index and boiling-point they are found to be entirely similar except that the curves for saturated cyclics are nearer to the curves for the paraffins in the refractive index diagram For a general picture Figs 1 and 2 may be used to obtain the density for a given type of compound of a given boiling-point, and then the corresponding representative refractive index may be obtained by means of the values for specific refraction or refractivity intercept given in Table VII

The curves in Fig 1 represent density boiling-point data for the following homologous series

- Curve I Normal paraffins C_n to C₁₁
- II High density paraffin isomers, especially 2,3 and 3,3-methyl and ethyl compounds
- III Normal olefines C_n to C₁₁
- IV Methyl and ethyl mono-alkyl derivatives of saturated cyclics, C₆ to C₉
- V Saturated cyclics, C₆ to C₉
- VI Cyclic mono-olefines, C₆ and C₇
- VII Cyclic diolefines, C₆ and C₇
- VIII Aromatic ring compounds benzene and naphthalene, the latter being in the hypothetical liquid state at 20° C

There is a rough parallelism between most of the curves of Fig 1 It is interesting to note that curve II diverges rapidly from curve I, which means that considerable error is involved in assuming that the curve for the normal paraffins may be used to represent all paraffins An approximate curve to represent paraffins in general could be drawn half-way between curves I and II

Fig 2 shows (1) the effect of alkyl substitution on the properties of compounds having a six-carbon atom ring, and (2) the grouping of paraffin isomers in general could be the cyclics

Note the following approximate mean boiling-points

6 carbon paraffins	60° C
6 carbon cyclics	80° C
7 carbon paraffins	90° C
7 carbon cyclics	105° C
8 carbon paraffins	115° C
8 carbon cyclics	130° C

This alternate grouping of cyclic and non-cyclic hydrocarbons is responsible for the alternation of high and low densities first observed by Mendeleeff [20, 1883], which has recently received much attention, for example, by Hill,

Henderson, and Ferris [14, 1927], and by Fenske [10, 1930]

The curves in Fig 2 have the following significance

- Curve I Cyclohexane and derivatives
 " II Cyclohexene and derivatives
 " III Cyclohexadiene and derivatives
 " IV Benzene and derivatives
 " E Connects 6 carbon atom compounds
 " F Connects 7 carbon atom compounds
 " G Connects 8 carbon atom compounds

- Group A Isomeric hexanes
 " B Nine isomeric heptanes and one octane (2,2,4-trimethyl pentane)
 " C Eleven isomeric octanes and one nonane (2,2,5-trimethyl hexane)
 " D Represents the known nonanes and decanes

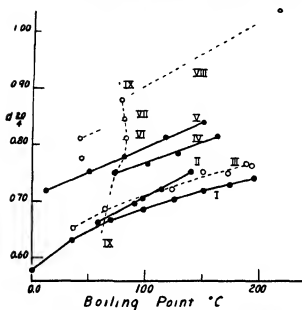

Fig 1 Density-boiling-point relation for homologous series

It is interesting to note that introduction of a methyl group in benzene and in cyclohexane increases the boiling-point and decreases the density. Beyond the monomethyl compound isomers of similar boiling-point and different densities are found so that the curve I divides into I a and I b, and curve IV divides into IV a and IV b. Most of the naphthenic isomers lie near curve I b, but most of the aromatic isomers lie near curve IV a.

Curves such as those shown in Figs 1 and 2 are helpful in fixing physical correlations in mind, but they must be used with caution in predicting the properties of compounds when only the structural formula is available. Many other interesting relations appear when the physical data for hydrocarbons are studied, paraffins and olefines are discussed in more detail elsewhere.

Specific and Molecular Refractivity.

In the preceding sections refractive index and density have been discussed first from the point of view of temperature change, and second from the point of view of molecular structure. These two lines of thought converge on the concept of specific and molecular refraction [7, 1912], since molecular refractions are supposed to be in-

dependent of temperature and directly related to composition.

The following formulae have been or are in extensive use

TABLE II
Refraction Formulae

Originator of formula	Specific refraction	Molecular refraction
Newton	$\frac{n^2-1}{d}$	
Berthelot		$\left(\frac{n^2-1}{d}\right)$ mol wt
Gladstone and Dale	$\frac{n-1}{d}$	$\left(\frac{n-1}{d}\right)$ mol wt
Lorentz and Lorenz	$\left(\frac{n^2-1}{n^2+2}\right) \frac{1}{d}$	$\left(\frac{n^2-1}{n^2+2}\right) \frac{\text{mol wt}}{d}$
Eykman	$\left(\frac{n^2-1}{n+0.4}\right) \frac{1}{d}$	$\left(\frac{n^2-1}{n+0.4}\right) \frac{\text{mol wt}}{d}$

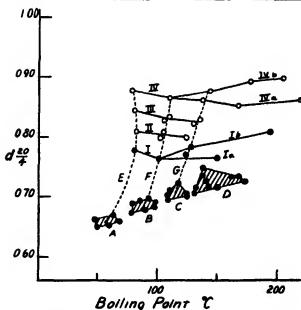

Fig 2 Density-boiling-point relation for 6-carbon cyclics and related compounds

The Lorentz and Lorenz equation has been widely used and has a theoretical derivation, but it is now becoming generally agreed that the empirical equation of Eykman [9, 1895] is more nearly independent of temperature than either the Lorentz-Lorenz or the Gladstone and Dale equation. The data of Table III illustrates this.

TABLE III
Data of Eykman Comparing Molecular Refraction Formulae [9, 1895]

Substance	Mol refraction at t_n						% change in mol ref		
	Temp °C	G & D	L & A	L	Eyk	G & D	L & A	Eyk	
Hexane	14	48.78	29.76	65.34					
	44-95	48.67	29.83	65.36		-0.23	+0.23	+0.03	
Paraffin, $C_{10}H_{22}$	38.3	157.43	94.48	208.95					
	136-0	156.50	95.00	208.62		-0.60	+0.54	-0.06	
Paraffin, $C_{12}H_{26}$	80.4	250.97	150.22	332.05					
	140-0	249.27	150.70	331.97		-0.32	+0.33	-0.02	
Cetene	20-2	125.61	75.24	166.57					
	140.5	124.70	75.80	166.51		-0.73	+0.75	-0.04	
Benzyl toluene	14.7	103.69	59.70	135.29					
	137.0	103.13	60.41	135.46		-0.55	+1.18	-0.12	

It is fair to say (1) that the Eykman formula is the more useful for expressing the relation between refractive index and density with changing temperature, (2) that the Lorentz-Lorenz is the more useful for bringing out the relation between optical and electrical properties, and that (3) the Gladstone and Dale equation is best (of these equations) for distinguishing between homologous series of hydrocarbons.

Having calculated molecular refraction it is natural to look for the existence of atomic refractions and to see if the molecular refraction is equal to the sum of the atomic refractions. An immense amount of effort has been expended on this problem, but the importance of structure is too great to permit highly accurate calculation of molecular refractions. Constants have long been used for structural features such as double bonds, ring-closure, conjugation of double bonds, etc., but it has generally been accepted that non-cyclic isomeric hydrocarbons should all have identical molecular refractions. The recent data of Smyth and Stoops [29, 1928] on the isomeric heptanes prepared by Edgar and Callingaert [5, 1929] show that in the case of these isomers there is a difference of about 1% between the maximum and minimum molecular refraction. These materials were prepared with great care and the data are very accurate, hence one must recognize the existence of appreciable constitution effects in these simple compounds. It should be noted at this point that Vlughter, Waterman, and Van Westen [30, 1935], and Ferns, Cowles, and Henderson [11, 1929, 12, 1931] have found good agreement between calculated and determined molecular refractions for a limited number of naphthenes and paraffins.

In the case of the classical work, a serious handicap was the lack of sufficient hydrocarbons of known structure and purity. The best of the older values for atomic refraction were given by Brühl. A more recent attempt to arrive at suitable constants was made by Eisenlohr [6, 1910]. These are usually given in recent text-books, although they are known to be in error. The values are now being recalculated by Huist [15, 1935] at Delft, and it is hoped that the new values will be more generally applicable.

The values (for the Lorentz-Lorenz formula, D line) for hydrocarbons now available are

TABLE IV
Atomic Refraction Values for Lorentz-Lorenz Formula

	Brühl	Eisenlohr	Huist
Carbon	2.501	2.418	2.590
Hydrogen	1.051	1.100	1.025
Double bond	1.707	1.733	
Triple bond	2.10	2.398	

Ring closure has a surprisingly small effect

Notwithstanding the fact that unimpeachable values have never been established, the work on molecular and atomic refraction has been of immense value historically in establishing the purity of individual hydrocarbons and in settling disputes about the structure of hydrocarbons, particularly among the terpenes. As our methods for the isolation of hydrocarbons are further refined and attempts are made to establish the structure of the complicated polycyclic hydrocarbons in the higher boiling fractions of petroleum, these constants will doubtless come into play again, as indicated by the work of Waterman [32, 1935].

Molecular Coefficient of Refraction.

One of the newer constants which have been proposed is the molecular coefficient of refraction, which is simply the refractive index multiplied by the molecular weight. Although Eisenlohr and Wohlsch [8, 1930] have made a strong plea for the use of this constant as reflecting constitutional influences to a greater extent than the refractivity expressions in which the division of the refractive index by the density tends to neutralize the effect of constitutional influences, others who have attempted to use it are not convinced that it offers any advantage over the classical expressions.

Specific Refractive Dispersion.

Dispersion, as stated above, is the difference in refractive index for light of two wave-lengths, specific dispersion is dispersion divided by density, both constants being determined at the same temperature. In order to express specific dispersion as a convenient whole number, it is multiplied by some power of 10. The most common formula for specific dispersion is

$$\frac{n_D - n_D'}{d} \times 10^4 \text{ or } \frac{\Delta n}{d} \times 10^4$$

Although dispersion never enjoyed the vogue which the various expressions for refractivity did in the classical work on the structure of organic compounds, and although it has never received the attention which such a useful tool in hydrocarbon analysis deserves, nevertheless various expressions for dispersion have been used by a number of investigators. Simple dispersion for several pairs of wave-lengths, the expression $\frac{n_D - n_D'}{n_D - 1} \times 10^4$ of Waterman and Perquin [34, 1927], and specific dispersion have all been used.

The formula $\frac{n_D - n_D'}{d} \times 10^4$ is in reality the difference in specific refraction for the two wave-lengths λ_1 and λ_2 according to the Gladstone-Dale formula, being a reduced form of the expression

$$\left(\frac{n_D - 1}{d} - \frac{n_D' - 1}{d} \right) \times 10^4$$

It should be noted, however, that the calculation of specific dispersion by the above formula does not require the calculation of specific refraction.

In one sense, it would be more logical for those who prefer the Lorentz-Lorenz formula for refractivity to use it also for dispersion. The equation for specific dispersion thus becomes

$$\left(\frac{n_D^2 - 1}{n_D^2 + 2d} - \frac{n_D'^2 - 1}{n_D'^2 + 2d} \right) \times 10^4$$

Using this equation, specific dispersion would no longer be defined as the difference in refractive indices divided by the density. This formula requires the calculation of specific refractivity. Numerically, specific dispersion by the Lorentz-Lorenz equation is equal to about one-half that by the Gladstone-Dale equation.

An enormous amount of effort was wasted and great confusion was introduced into the literature on refractivity by the conflict between the (German) school of thought which used the Lorentz-Lorenz equation and the (English) school which used the Gladstone-Dale equation.

Some investigators have started to use the Lorentz-Lorenz equation for specific dispersion. It will be regret-

table if the dispersion literature ever becomes as confused as did the refractivity literature. The simpler a tool, the more useful it is. The confusion and complication resulting from introducing an involved equation to replace a simple one can only be justified if the more complicated one can be demonstrated to represent the facts more truly. In the present instance no such demonstration has been offered.

Although any pair of spectrum lines may be used in any equation for dispersion or specific dispersion, the more widely separated the wave-lengths, the more clear cut become the differences between the different hydrocarbon series. The older work used the pair *F* and *C* because these lines were used to characterize optical glass. Dixmer [4, 1926] and Mutte [22, 1926] have used the pair *g* and *D*. Waterman and his co-workers [30, 1935, 33, 1932, 34, 1927], Darmois [2, 1921], and others have used the pair *G'* and *C*. It is much easier to obtain a brilliant *g* line than a *G'* line of sufficient intensity for accurate measurements. As a matter of fact, the *G'* line cannot be read at all with turbid or coloured oils. For that reason Ward and Fulweiler [31, 1934] used this pair in a recent attempt to popularize the use of specific dispersion in the analysis of hydrocarbon mixtures. The difference of 18 Å between the *g* and *G'* lines is so small that negligible errors are introduced in converting indices obtained by one line to the other, using the formula of Cauchy.

The values for specific dispersion for different hydrocarbon series have been summarized in Table V. Some values for the Lorentz-Lorenz equation have been included for comparison.

TABLE V
Specific Refractive Dispersion of Hydrocarbons

Authors	Ward and Fulweiler [31, 1934]		Darmois [2, 1921]		Vlugter, Waterman, and Van Westen [30, 1935]	
	Gladstone Dale <i>g-C</i>	Gladstone- Dale <i>G'-C</i>	Gladstone- Dale <i>G'-C</i>	Gladstone- Dale <i>G-C</i>	Lorentz- Lorenz <i>G-C</i>	
Spectrum lines						
Hydrocarbon series						
Paraffins	153	155	} 150-8	} 76-87		
Naphthenes (saturated monocyclic)	154	151				
Olefines (1 double bond)	187	194				
Unsaturated monocyclic (1 double bond)	186	191				
Diolefines	216	230				
Conjugated diolefines*	354					
Unsaturated cyclics (two* conjugated double bonds)	295					
Saturated cyclics with one* double bond in side chain	201					
Unsaturated cyclics with one* double bond in side chain	214					
Aromatics†	307-260	305			307-281	152-138
Aromatic olefin† (one double bond)	355					
Naphthalene	490		496	229		
Some naphthalene derivatives			436-46	201-19		
Diphenyl			447	206		
Some hydrocarbons with two phenyl nuclei			320-3	150-2		

* The number of hydrocarbons of these series for which data are available is too limited to permit the establishment of their dispersions with the accuracy characteristic of the other series.

† The values decrease with increasing molecular weight, that is, as the paraffinic character of the molecule increases.

Vlugter, Waterman, and Van Westen observe that for cyclic hydrocarbons the specific dispersion of only the saturated monocyclics is entirely independent of molecular weight. For paraffins it decreases slightly, and for poly-

cyclics it increases slightly with molecular weight. This is shown in their summation, in which *n* equals the number of carbon atoms.

TABLE VI
Effect of Molecular Weight on Dispersion (Lorentz-Lorenz Formula) of Saturated Hydrocarbons

	<i>n</i> = 20 (mol wt about 280)	<i>n</i> = 30 (mol wt about 420)	<i>n</i> = 40 (mol wt about 560)
Paraffins (C _n H _{2n+2})	82.1	81.6	81.3
Monocyclic naphthenes (C _n H _{2n})	80.6	80.6	80.6
Dicyclic naphthenes (C _n H _{2n-2})	79.1	79.6	79.9
Tetracyclic naphthenes (C _n H _{2n-6})	77.6	78.6	79.1
Pentacyclic naphthenes (C _n H _{2n-10})	76.1	77.6	78.3
Pentacyclic naphthenes (C _n H _{2n-10})	74.5	76.5	77.4

The uses to which specific dispersion have been put are varied. In general, it is most valuable when used in connexion with some other physical or chemical property. For example, paraffins and naphthenes cannot be distinguished because their values are the same. The aromatics are much higher, and specific dispersion may be used to determine aromatics (single ring) as Darmois used it on gasoline. On the other hand, the specific refractions of the aromatics and paraffins lie relatively close together, but the values for naphthenes are lower. The two sets of constants may, therefore, be used to characterize a mixture of the three series.

Waterman and his co-workers use dispersion to control the complete saturation of hydrocarbon oils.

Ward and Fulweiler used dispersion in checking the concentration and character of unsaturated hydrocarbons in aromatics and the presence of saturated hydrocarbons in the same mixture.

Refractivity Intercept.

A valuable new concept of refractivity has recently been introduced by Kurtz and Ward [18, 1936]. This constant for any homologous series is defined as the intercept of the refractive index-density curve with the refractive index ordinate if the abscissa scale begins with zero density. It is, therefore, the hypothetical refractive index at zero density. The equation is $R \text{ Int} = n - d/2$.

The following values have been established for nine series of hydrocarbons.

TABLE VII
Refractivity Intercepts for Hydrocarbons

Series	<i>R Int</i> at 20° C †
Paraffins	1.0461
Saturated monocyclic	1.0400
Saturated polycyclic*	1.0285
Monocyclics	1.0521
Diolefines	1.0592
Conjugated diolefines*	1.0877
Unsaturated cyclics, one double bond	1.0461
Unsaturated cyclics, two conjugated double bonds*	1.0643
Aromatics	1.0627

† Based on data for pure compounds compiled by Ward and Kurtz, to be published.

* The number of hydrocarbons of these series for which data are available is too limited to permit the establishment of the values for their intercepts with the accuracy characteristic of the other series.

The value of the refractivity intercept lies in the facts that for hydrocarbon isomers it is more constant than specific refraction, and that unlike specific dispersion it may

be obtained accurately using only white light and an Abbe refractometer and an hydrometer

In practical application its chief uses are (1) rapid checking of physical property data for supposedly pure compounds found in the literature, and (2) distinguishing between naphthenes, paraffins, and aromatics in hydrocarbon mixtures

Refractive Index and Dielectric Constant.

According to the electromagnetic theory of light the dielectric constant equals the square of the refractive index [13, 1929, 26, 1928] The refractive index and dielectric constant should strictly be obtained at the same frequency, but practically it is possible to use dielectric constants obtained with low-frequency waves and refractive indices obtained with sodium light and to obtain quite good agreement, as shown in Table VIII The dielectric constant obtained in this way is a minimum Natural polarity of the molecules or contamination with polar material will give a higher dielectric constant Assuming that there is no contamination, the difference between the dielectric constant and the square of the refractive index may be used to calculate the molecular moment [3, 1929]

The relation between refractive index and dielectric constant is occasionally useful in estimating the dielectric constant of an oil without actually determining it The

temperature coefficient of the dielectric constant may also be approximated by calculating the refractive index at several temperatures and squaring to obtain the dielectric constant

TABLE VIII
Calculation of Dielectric Constant from
Refractive Index

Compound	Source of data	T °C	Refractive index n_D	n_D^2	Dielectric constant	Difference calc and exper
n-heptane	[29, 1928]	20	1.38777	1.926	1.930*	+0.004
2-methyl hexane	"	"	1.38509	1.918	1.922	+0.004
3-methyl hexane	"	"	1.38873	1.929	1.930	+0.001
3-methyl pentane	"	"	1.39366	1.942	1.942	0.000
2,2-dimethyl pentane	"	"	1.38233	1.911	1.915	+0.004
2,4-dimethyl pentane	"	"	1.39201	1.938	1.942	+0.004
2,4-dimethyl pentane	"	"	1.38233	1.911	1.917	+0.006
3,3-dimethyl pentane	"	"	1.39114	1.935	1.940	+0.005
2,2,3-trimethyl pentane	"	"	1.38940	1.930	1.930	0.000
Oil from petroleum?	[23, 1931]	0	(1.5199)	2.31	2.342	+0.03
		25	1.5077	2.27	2.302	+0.03
		50	(1.4933)	2.23	2.262	+0.03

* Dielectric constant at 5×10^4 cycles (600 meters wave-length)

† n_D at 100° C = 0.9685 n_D at 30° C = 0.8654 vhc 100° C = 0.27

‡ Dielectric constant at zero frequency

REFERENCES

- CLARKE, L. *JACS* 31, 107 (1909), 33, 523 (1911), 34, 54, 60, 674, and 680 (1912)
- DARMOCH, E. *Compt rend* 171, 925 (1920), 172, 1102 (1921)
- DEBYE, P. *Polar Molecules*, 42 (Chemical Catalogue Co., New York, 1929)
- DIXMÉR, G. *Chimie et Industrie*, Special No., 338 (1926)
- EDGAR, G., and CALINGBERT, G. *JACS* 51, 1546 (1929)
- EISENLOHR, F. *Z Phys Chem* 75, 500 (1910)
- Spectrochemie Organischer Verbindungen (F Enke, Stuttgart, 1912)
- EISENLOHR, F., and WÜHLICH, E. *Ber* 53 a, 1746 and 2053 (1930)
- EYKMAN, J. F. *Recueil des travaux chimiques des Pays-Bas*, 15, 56 (1895)
- FONKE, M. R. *Ind Eng Chem* 22, 913 (1930)
- FERRIS, S. W., COWLES, H. C., JR., and HENDERSON, L. M. *Ind Eng Chem* 21, 1092 (1929)
- *Ind Eng Chem* 23, 682 (1931)
- GEMANT. *Liquid Dielectrics*, 93 (John Wiley & Sons, New York, 1929)
- HILL, J. B., HENDERSON, L. M., and FERRIS, S. W. *Ind Eng Chem* 19, 128 (1927)
- HULET, L. J. N. VAN DER. *Rec trav chim* 54, 518 (1935)
- KOHLRAUSCH, F. *Praktische Physik* (B G Teubner, Leipzig, 1935)
- KOPF, V. HERMANN. *Pogg Ann* 47, 113 (1889), 52, 262 (1844), *Ann* 41, 79 (1842), 96, 153 and 303 (1855), 290, 1 (1889)
- KURTZ, S. S., JR., and WARD, A. L. *J Franklin Inst* 221 (1936)
- LE BAÉ, G. *The Molecular Volumes of Liquid Chemical Compounds* (Longmans, Green & Co., London, 1915)
- MENDELÉEFF, D. I. (1883) quoted by Gutwisch, L. and Moore, H. *Scientific Principles of Petroleum Technology*, 7 (Chapman & Hall, London, 1926)
- MORGAN, G. T., CARTER, S. R., and DUCK, A. E. *JCS* 127, 1255 (1925)
- MUTTÉ, R. *Chimie et Industrie*, Special No., 338 (1926)
- RACH, H. H. *Phys Rev* 37, 430 (1931)
- RICHARDS, T. W. *Proc Amer Acad Arts and Sciences*, 39, 600 (1904)
- *Faraday Lect JCS* 199, 1201 (1911)
- RICHTMEYER, F. K. *Introduction to Modern Physics* (McGraw Hill Book Co., New York, 1928)
- SCHMITT, G. G., and BOARD, C. E. *JACS* 54, 751 (1932)
- SELLMEIER, W. *Pogg Ann* 143, 272 (1871)
- SMYTH, C. P., and STOOPS, W. N. *JACS* 56, 1885 (1934)
- VLUGTER, J. C., WATERMAN, H. I., VAN WESTEN, H. A. *J IPT* 21, 661, 701 (1935)
- WARD, A. L., and FULWELER, W. H. *Ind Eng Chem*, Anal Ed 6, 396 (1934)
- WATERMAN, H. I. *J IPT* 21, 701 (Aug 1935)
- WATERMAN, H. I., and his co-workers. *Kon Acad v Wetenschappen to Amsterdam* 35 (2), 1063 (1932), *J IPT* 19, 784 (1933), 20, 239 A (1934), *Proc World Petr Cong* 2, 322 (1933), *Rec trav. chim P B* 53, 699, 715, 821 (1934)
- WATERMAN, H. I., and PERQUIN, J. N. J. *J IPT* 13, 413 (1927)

DENSITY AND REFRACTIVE INDEX OF CRUDE PETROLEUM, GASOLINE, KEROSENE, GAS OIL, AND FUEL OILS

By A. L. WARD, Manager, The Chemical Laboratories, The United Gas Improvement Company, S. S. KURTZ, Jr., Development Engineer, The Sun Oil Company, W. H. FULWEILER, Consulting Chemical Engineer

Additivity of Physical Properties

The refractive index and density of binary mixtures of liquids which mix without change in volume are additive on a volume per cent basis. The careful work of MacFarlane and Wright [20, 1933] settles this point definitely.

Specific refraction, in which weight occurs in the denominator, is additive on a weight per cent basis. For mixtures of hydrocarbons not differing greatly in density the per cent by volume and the per cent by weight do not differ greatly, hence the difference between per cent by weight and per cent by volume is not important except in special cases.

In complex mixtures such as those encountered in petroleum fractionation one may safely assume that any change in volume which occurs on mixing is small (0.25% or less) [30, 1933] and that the refractive index or density of any blend may be computed if the refractive indices and densities of the materials to be mixed are known.

Composition of Petroleum as indicated by Work of Bureau of Standards

The physical properties of natural petroleum products may be used to obtain some idea of the composition of these complex mixtures. In order to be sure that the conclusions arrived at by such methods are correct, it is necessary that a few samples of petroleum shall have been separated into the actual pure compounds of which they are composed. This is a tremendous undertaking. C. F. Mabery devoted his life to this type of work and examined many samples with moderate but not complete thoroughness.

The American Petroleum Institute Research Project No. 6, carried out at the Bureau of Standards, is the most thorough programme of this sort ever undertaken [32, 1933].

The investigation was inaugurated by the late Dr. Washburn and has been continued under the direction of Dr. Rossini. In this work Mid-Continent crude from South Panca Field, Kay County, Oklahoma, was fractionated and the cuts were repeatedly refractionated. Thus far approximately 40 man years of work have been expended on the examination of the naphtha fraction boiling between 55 and 180° C. [19, 1935, 26, 1935]. This work is far from complete, but considerable information is available for the material boiling between 55 and 145° C. as indicated in Fig. 1 and Table I.

Fig. 1, which was compiled by Leslie and White and is republished through the courtesy of the National Bureau of Standards, gives the volume per cent of the 1° C. cuts and the corresponding refractive indices of these cuts. Some, but not all, of the pure compounds isolated from this naphtha are indicated on this graph by vertical lines. The percentage of the separated pure compound is indicated by the height of the line referred to the right-hand scale. All percentages are calculated on the basis that the initial volume of the 55-145° C. cut was 100%.

TABLE I

Summary of Isolated, Detected, and Suspected Hydrocarbons in the 55-145° C. Fraction of a Mid-Continent Petroleum

Type	Isolated		Detected or suspected		Total		Known* hydrocarbons reported boiling in range 55-145° C.
	No.	Estimated relative percentage	No.	Estimated relative percentage	No.	Estimated relative percentage	
Paraffins	9	40	14	20	23	60	41
Naphthenes†	7	15	11	15	18	30	37
Saturated Aromatics	6	10			6	10	4
Total	22	65	25	35	47	100	88

* Literature values

† Saturated monocyclics

Table I is especially significant since it presents the only really reliable estimate of the composition of a natural naphtha that has ever been published. Rossini and his associates present their data with many qualifications as to quantitative accuracy, but this work is nevertheless the best in the literature. The ratio 60% paraffin, 30% naphthene, and 10% aromatic in a Mid-Continent naphtha is well established.

This information somewhat simplifies the problem of evaluating the significance of the refractive index and density of 'straight-run' naphthas.

The Density of Crude Petroleum

Crude petroleum varies from material of the Mexican and Trinidad types which contain a large proportion of asphalt and have specific gravities in the vicinity of 1.0, to material of water-white colour and low density which can be used directly as a motor fuel. Crudes of the latter type are, however, sufficiently rare, so that they are not of commercial importance. In fact, most crudes are so dark that refractive indices cannot be taken by the ordinary methods, hence no refractive index data are tabulated in this section.

Since it is standard practice to record the API gravity or the specific gravity 60°/60° F. for crudes, tabulations in this section are based on specific gravity 60°/60° F. in order to permit comparison between data for crudes and different fractions.

The United States Bureau of [Mines 17, 1935, 28, 1928] has published an immense amount of data on the gravity of crude petroleum and its fractions, and on the basis of this work they recommend the classification of crudes into three major classes and four sub-classes. Table III gives density data for crudes representative of each of these classes. It is clear that gravity of the whole crude is not a very reliable guide to the type of crude. The Bureau of Mines system of classification is based upon distillation through a Hempel-type column to 275° F. at atmospheric pressure and from that point to 300° C. at 40 mm. Hg. pressure. Cuts are taken every 25° C. The cut from 250 to 275° C. at atmospheric pressure is called 'Key fraction

No 1', and the cut from 275 to 300° C at 40 mm is called 'Key fraction No 2'. Key fraction No 1 is taken as representative of the quality of the naphtha, Key fraction No 2 is taken as representative of the lubricating oil. These

for example, 'Intermediate Paraffin Base' means that the naphtha is of intermediate type and the viscous oils are of paraffinic type.

The wide variations in specific gravity of crudes, even

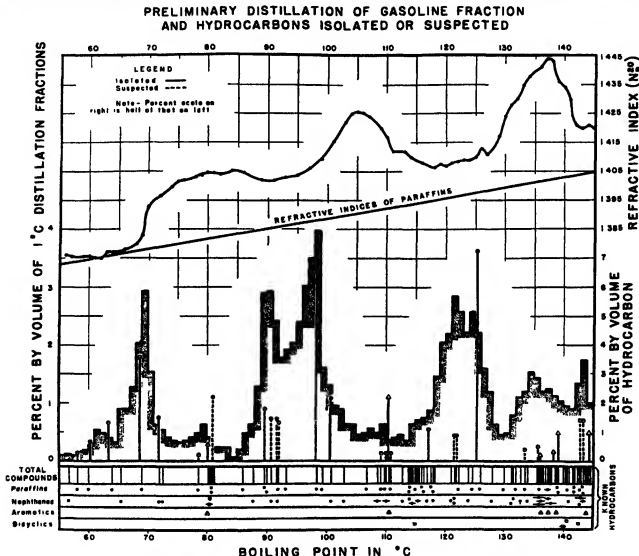

FIG 1 American Petroleum Institute project 6, preliminary distillation of gasoline fraction

fractions are classified on the basis of gravity as follows (Table II)

TABLE II
Key Fraction Classification for Determining the Base of Crudes

	Key fraction No 1		Key fraction No 2	
	Sp gr 60° F	*API	Sp gr 60° F	*API
Paraffin	0.8251 and less	40 and greater	0.8762 and less	30 and greater
Inter-mediate	0.8256-0.8597	33.1-39.9	0.8767-0.9334	20.1-29.9
Naphthene	0.8602 and greater	33.0 and less	0.9340 and greater	20.0 and less

In naming the four mixed-type classifications, the first part of the name indicates the No 1 key fraction; the second part of the name indicates the No 2 key fraction,

from one geographical area or field, are shown in Tables IV and V. Table IV gives maximum and minimum values for crudes from all parts of the world. Table V gives the range of gravities for which specific quotations are made on current American crudes. Crudes with gravities above and below the gravities indicated in Table V may be obtained from a particular field, but are not usual.

Inspection of Tables IV and V shows that the specific gravity of most crudes lies between 0.80 and 0.95 (54.4 and 17.4° API). Variation of the gravity of the crude from a given field is usually due to the difference in the percentage of gasoline and naphtha in the crude, as indicated in Fig 2. Curve I in this graph represents Pennsylvania crude, curves II and III various Oklahoma crudes, and curve IV Kern County, California, crude. The rough proportionality between specific gravity and per cent naphtha in any given field accounts for the importance attached to gravity in the market quotations on crudes.

DENSITY AND REFRACTIVE INDEX OF CRUDE PETROLEUM, GASOLINE, AND KEROSENE 1179

 TABLE III
 Gravity of Various Classes of Crudes [17, 1935]

Primary classification	Detailed classification	Representative crude	Sp. gr. 60°/60°F	*API at 60°F
Paraffin base	Paraffin base (Wax-bearing)	Lost Run Field, Richlie County, West Virginia	0.781	49.7
	Paraffin intermediate base (Wax-bearing)	Chandler Field, Lincoln County, Oklahoma	0.629	39.2
Intermediate base	Intermediate paraffin base (Wax-bearing)	Cotton Valley Field, Webster Parish, Louisiana	0.879	29.5
	Intermediate base	Seminole Field, Seminole County, Oklahoma	0.827	39.6
	Intermediate naphthene base (Wax-bearing)	North Sunshine Field, Park County, Wyoming	0.964	15.3
Naphthene base	Naphthene intermediate base (Wax-bearing)	Racon Bend Field, Austin County, Texas	0.679	29.5
	Naphthene base (Wax free)	Refugio Field, Refugio County, Texas	0.910	24.0

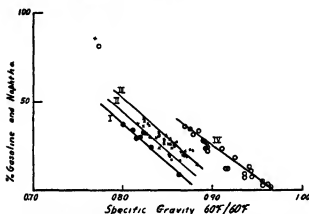

FIG 2 Relation between specific gravity and per cent of naphthene in crudes from a given field

 TABLE IV
 Gravity of Crude Petroleum—Maximum and Minimum Values [14, 1927]

Continent	Country or district	Gravity *API	Sp. gr. 60° F
Africa	Algeria	12.9-47.6	0.79-0.98
	Egypt	14.4-39.0	0.83-0.97
	Gold Coast	12.9-31.1	0.87-0.98
	Ivory Coast	15.9	0.96
	Sud. Brahum	7.2	1.02
	Tunis	14.4	0.97
Asia	Assam	12.9-32.9	0.86-0.98
	Burma	10.0-43.2	0.81-1.00
	Japan	12.9-43.4	0.80-0.98
	Borneo	14.4-33.0	0.86-0.97
	Java	14.4-43.2	0.81-0.97
	Roengkoet Iran	14.4	0.97
		2.0-49.7	0.78-1.06
Australia		14.4-37.0	0.84-0.97
New Zealand		14.4-37.0	0.84-0.97
Europe	Russia (Daghestan)	15.9-35.0	0.85-0.96
	„ (Caucasus)	86.2	0.65

TABLE IV (cont)

Continent	Country or district	Gravity *API	Sp. gr. 60° F
Europe	Galacia (Drohobycz)	15.9-37.0	0.84-0.96
	Germany	10.0-43.2	0.81-1.00
	Greece	12.9-31.1	0.85
	Hungary	12.9-45.4	0.80-0.98
	Italy	14.4-57.2	0.75-0.97
	Roumania	17.5-52.3	0.77-0.95
North America	Canada	14.4-57.2	0.75-0.97
	Cuba	15.9-62.3	0.73-0.96
	Haiti	15.9-22.3	0.82-0.96
	Mexico	2.0-47.6	0.79-1.06
	United States (Alaska)	11.4-47.6	0.79-0.99
	„ (California)	8.6-52.3	0.77-1.01
	„ (Louisiana)	14.4-45.4	0.80-0.97
	„ (Oklahoma)	29.3-47.6	0.79-0.88
	„ (Texas)	14.4-45.4	0.80-0.97
	„ (Utah)	17.5-39.0	0.83-0.95
	„ (Wyoming)	10.0-45.4	0.80-1.00
	„ (Pa)	27.5-70.6	0.70-0.89
South America	Argentina	10.0-25.7	0.90-1.00
	Barbados	14.4-29.3	0.88-0.97
	Colombia	14.4-33.0	0.86-0.97
	Ecuador	11.4-29.3	0.88-0.99
	Peru	17.4-41.1	0.82-0.95
	Trinidad	12.9-43.2	0.81-0.98

 TABLE V
 American Fields for which Crude Prices are quoted by Gravity [33, 1935]

State	Field	Range of gravity at 60° F for which quotations are made	
		*API	Sp. gr.
Oklahoma and Kansas		25.7-41.0	0.82-0.90
Texas	North Central, and East Central Gray, Carson, Hutchinson, and Moore Counties	29.3-41.0	0.82-0.88
	Conroe	35.0-41.0	0.82-0.85
		37.0-41.0	0.82-0.84
Texas and Louisiana	Gulf Coast, Texas, and Louisiana	20.6-41.0	0.82-0.93
Louisiana	Cotton Valley	25.7-41.0	0.82-0.90
Louisiana and Arkansas	Northern Louisiana and Arkansas	29.3-41.0	0.82-0.88
Wyoming	Salt Creek	29.3-41.0	0.82-0.88
California	Montebello	14.4-41.0	0.82-0.976
	Kettleman Hills	33.0-39.8	0.826-0.80
	Santa Fe Springs	21.0-39.0	0.830-0.928
	Elwood Terrace	33.0-38.0	0.815-0.800
	Coyote Hills	14.4-34.0	0.855-0.97
	Mountain View	19.0-34.0	0.835-0.94
	Midway-Sunset, Elk Hills, Buena Vista Hills	14.4-33.0	0.860-0.97
	Inglewood	14.4-32.1	0.865-0.97
	Albena, Rosecrans, Dominguez, Signal Hill, Seal Beach, Alamitos	23.0-32.1	0.865-0.916
	Hoghts, Huntington Beach, Lost Hills	14.4-31.0	0.871-0.97
	Ventura Avenue, Rincon	21.9-31.0	0.871-0.922
	Clinda-Brea Canyon	14.4-28.9	0.882-0.97
	Playa Del Rey	14.4-27.0	0.893-0.97
	Coolidge	14.4-25.9	0.899-0.97
Wheeler Ridge	19.8-25.9	0.899-0.935	
Whittier, La Habra	14.4-24.8	0.905-0.97	
Kern River, Newhall, McKintuck, Round Mountain	13.9-19.9	0.935-0.973	

The increase in density for the same percentage of naphthene as one progresses from Pennsylvania to Kern County, California, crudes reflects the increasing proportion

of cyclic compounds in the latter crudes. This is also shown by the carbon/hydrogen ratio which is about 6.0 for Pennsylvania crudes and 7.6 for Kern River crude.

The paraffinic or naphthenic viscosity of a crude may be estimated from the gravity and viscosity by means of the viscosity-gravity constant. Paraffinic crudes have a v/gc of approximately 0.80-0.81, Mid-Continent 0.825-0.845, and Gulf Coast 0.850-0.920. The formula for v/gc and a nomogram for calculating this constant are given in another article [34].

There is no definite relation between the density of a crude and the per cent sulphur, although the per cent sulphur is likely to be high in high-density crudes.

Density and Refractive Index of Petroleum Fractions

General Division of Crude into Fractions.

It is customary in refining petroleum to divide the crude into fractions approximately as follows:

Fixed gases	Ethane and lighter
Liquefied fuel gases	Propane and butane
Gasoline and naphtha	Pentane to material boiling at 200-220° C
Kerosene	Boiling range approximately 200-300° C
Gas oil	Cut heavier than kerosene and with viscosity less than 50 sec Saybolt at 100° F (0.073 Stokes)
Lubricating oil	50-4,000 sec Saybolt at 100° F, or 150 sec Saybolt at 210° F (0.073-8.67 Stokes at 100° F or 0.316 Stoke at 210° F)
	Fuel oil, tar, or asphalt in crudes containing these

In Table VI [14, 1927] data are given showing the approximate specific gravity range for some typical straight-run petroleum products. Since such a wide variety of crudes are to-day available, and since cracking and re-forming

have become important, density specifications no longer serve to specify a product as was the case in America when straight-run Pennsylvania products only were available. Table VI is therefore of more historic than practical value. Table VII presents recent data for the gravities of narrow cuts from three representative crudes, and of the major products which can be obtained from these crudes.

TABLE VI
Straight-run Petroleum Products
API gravity and approximate specific gravity range at 60° F

	Sp gr	*API
<i>Paraffin base crude</i>		
Light petroleum ether	0.626-0.633	92.0-94.5
Heavy " "	0.639-0.654	84.9-90.0
Natural gas gasoline	0.622-0.675	78.1-96.4
Gasoline	0.709-0.747	57.9-68.1
Kerosene	0.797-0.816	41.9-46.0
Mineral seal oil (300 burning oil)	0.811-0.825	40.0-43.0
Gas oil	0.816-0.875	36.0-41.9
Non-viscous neutrals	0.850-0.865	32.1-35.0
Viscous neutrals	0.865-0.882	28.9-32.1
Paraffin oils	0.875-0.904	25.1-30.2
Paraffin wax	0.871-0.947	17.9-31.0
Red oils	0.904-0.910	24.0-25.0
Filtered cylinder stock	0.887-0.896	26.4-28.0
Bright stock	0.893-0.916	23.0-27.0
Steam-refined oils	0.898-0.928	21.0-21.0
<i>Naphthene base crude</i>		
Natural gas gasoline	0.669-0.702	70.0-80.0
Light gasoline	0.702-0.720	65.0-70.1
Gasoline	0.731-0.763	54.0-62.1
Kerosene	0.816-0.825	40.0-41.9
Gas oil	0.855-0.875	32.0-34.0
Low pour test machine oil (low viscosity)	0.922-0.928	21.0-22.0
" " " (medium ")	0.928-0.934	20.0-21.0
" " " (high ")	0.934-0.940	19.0-20.0
Black oil	0.940-0.947	17.9-19.0
Flux	0.973-0.986	12.0-13.9

TABLE VII

Fractions from Three Representative Crudes [17, 1935]

Temp °C	Pressure*	Paraffin base crude, Lost Run Field, Ritchie County, W. Va			Intermediate base crude, Seminole Field, Seminole County, Okla			Naphthene base crude, Refugio Field, Refugio County, Texas		
		% cut	Sp gr 60°/60° F	*API 60° F	% cut	Sp gr 60°/60° F	*API 60° F	% cut	Sp gr 60°/60° F	*API 60° F
Up to 50	A	4.6	0.647	87.2	3.3	0.643	88.6			
50-75	A	4.5	0.656	84.2	3.4	0.669	80.1			
75-100	A	7.0	0.692	73.0	6.5	0.709	68.1			
100-25	A	9.1	0.724	63.9	7.7	0.736	60.8			
125-50	A	7.5	0.743	58.9	6.6	0.757	55.4			
150-75	A	7.0	0.758	55.2	5.8	0.777	50.6	1.1	0.803	44.7
175-200	A	5.5	0.770	52.3	5.3	0.794	46.7		0.825	38.0
200-25	A	5.3	0.780	49.9	4.9	0.810	43.2	8.3	0.855	34.0
225-50	A	5.6	0.791	47.4	5.2	0.826	39.8	13.3	0.872	30.8
250-75	A	6.8	0.803	44.7	5.8	0.840	37.0	19.6	0.888	27.9
Up to 200	40 mm	3.6	0.826	39.8	3.1	0.859	33.2	10.6	0.907	24.5
200-25	40 mm	5.1	0.832	38.6	3.3	0.865	32.1	10.3	0.915	23.1
225-50	40 mm	4.5	0.839	37.2	4.6	0.879	29.5	7.2	0.928	21.0
250-75	40 mm	3.9	0.845	36.0	4.1	0.893	27.0	5.8	0.942	18.7
275-300	40 mm	4.4	0.853	34.4	4.9	0.905	24.9	7.3	0.956	16.5
Gasoline and naphtha		45.2	0.718	65.6	38.6	0.715	61.0	1.1	0.803	44.7
Kerosene		17.7	0.792	47.2	4.9	0.810	43.2			
Gas oil		8.3	0.829	39.2	17.3	0.843	36.4	55.5	0.879	29.5
Light lub oil		9.8	0.835-0.851	38.0-34.8	9.4	0.866-0.895	31.9-26.6	14.2	0.901-0.929	23.8-20.8
Medium lub oil		3.4	0.851-0.857	34.8-33.6	6.3	0.895-0.911	26.6-23.8	4.7	0.929-0.939	20.8-19.2
Viscous lub oil								11.6	0.939-964	19.2-13.7
Residuum		14.7	0.888	27.9	22.1	0.958	16.2	12.7	0.981	12.7
Dist loss		0.9			1.4			0.2		

* Atmospheric pressure during distillations as follows: paraffin base 750 mm., intermediate base 737 mm., naphthene base 747 mm.

Liquefied Petroleum Gas.

The method used for determining the density of liquefied petroleum gases is given in the article on 'The Determination of Density and Refractive Index of Pure Hydrocarbons and Petroleum Products'

The commercial liquefied petroleum gases consist of propane, butane, and a mixture known as 'Propane-Butane' which contains about 30% of propane, so that the mixture will have a higher vapour pressure than liquefied butane. There is considerable variation in the composition of these commercial gases, since some contain appreciable quantities of olefines and some do not. Commercial 'Butane' may vary as much as 0.01 in specific gravity. Table VIII gives physical property data for liquefied petroleum gases which will be found reasonably representative. For a further discussion, see Finley [7, 1935].

TABLE VIII
Gravity of Commercial Liquefied Gases

	Propane	Butane
Sp gr 60°/60° F	0.509	0.576
* API 60° F	146.4	114.2

A practical relation for air-free petroleum gases is that there is a linear relation between heating value in B Th U per cu ft (60° F., 30 in Hg) and specific gravity of the gas. The equation B Th U / cu ft = 1.550(sp gr - 0.550) + 1,000 holds with reasonable accuracy for gases containing 10% or less hydrogen.

In connexion with shipping liquefied petroleum gases, the term 'filling density' is used to specify the ratio of the weight of petroleum gas that can safely be loaded in a container to the weight of water that the container will hold. The Bureau of Explosives, 30 Vesey Street, New York City, sets specifications for various types of containers, one such table being given herewith.

TABLE IX

Minimum specific gravity of liquid material at 60° F	Maximum filling density in per cent of the weight capacity of the container	Minimum specific gravity of liquid material at 60° F	Maximum filling density in per cent of the water-weight capacity of the container
0.271-0.289	26	0.504-0.510	42
0.290-0.306	27	0.511-0.519	43
0.307-0.322	28	0.520-0.527	44
0.323-0.338	29	0.528-0.536	45
0.339-0.354	30	0.537-0.544	46
0.355-0.371	31	0.545-0.552	47
0.372-0.398	32	0.553-0.560	48
0.399-0.425	33	0.561-0.568	49
0.426-0.440	34	0.569-0.576	50
0.441-0.452	35	0.577-0.584	51
0.453-0.462	36	0.585-0.592	52
0.463-0.472	37	0.593-0.600	53
0.473-0.480	38	0.601-0.608	54
0.481-0.488	39	0.609-0.617	55
0.489-0.495	40	0.618-0.626	56
0.496-0.503	41	0.627-0.634	57

Density and Refractive Index of Gasoline and Kerosine.

Table X presents data on the physical properties of naphthas, arranged so that the naphthas, or cuts of these naphthas, may be compared. Over-point to 200° C may be taken as gasoline, and 200-300° C as kerosine. Data for the 100-200° C cut have been given so that comparable data for a uniform boiling range would be available.

The consideration of narrow cuts is greatly complicated by the existence of constant-boiling mixtures which frequently result in the isolation of a hydrocarbon as a mixture boiling 5-10° C from the true boiling-point of the major component and requiring further treatment by other physical means for separation of the pure compound.

The most interesting thing about the fractionation of a naphtha into close cuts is that it is possible to concentrate the alternate non-cyclic and cyclic groups [35]. According to Gurwitsch [8, 1926], Mendeleeff was the first to notice this. In 1883 Mendeleeff published the following data for repeatedly distilled fractions of Baku naphtha.

Boiling limits, ° C	Sp gr	Comment of Editor Peak or valley caused by following groups
56-7	0.675	5 carbon cycles
61-3	0.672	6 " paraffins
79-81	0.7483	6 " cycles
89-91	0.7337	7 " paraffins
99-101	0.7609	7 " cycles
109-11	0.7539	8 " paraffins
119-21	0.7659	8 " cycles

This type of close fractionation has in recent years been much refined, for example, by Hill, Henderson, and Ferris [10, 1927], by Fenske [4, 1930], Fenske, Quiggle, and Tongberg [5, 1932], and by the group working at the Bureau of Standards [19, 1935]. The degree of concentration of cycles and paraffins in particular cuts depends upon the efficiency of fractionation. If density-boiling-point or refractive index-boiling-point curves are plotted, there are always peaks and valleys at about the points observed by Mendeleeff. This type of fractionation has been considered as a means of concentrating material of good antiknock quality [4, 1930, 9, 1932].

It is not possible to compare naphthas on the basis of the properties of these various cuts unless the naphthas in question have been fractionated under identical conditions. The following data indicate this.

Ref	Straight run naphtha from	Boiling-point of narrow cut representing peak in b p density curve	d ₄ ²⁰	n _D ²⁰	Degree of fractionation
[8, 1927]	California crude	79° C	0.738	1.4091	Good
[3, 1932]	Pennsylvania crude	79° C	0.740	1.4081	Excellent

In view of these difficulties in comparing narrow cuts from different naphthas it was decided to omit tabulation of such data in this article. The term 'narrow cut' in connexion with laboratory fractionation of gasoline may be taken to mean a cut (a) representing 2½% or less of the original naphtha, or (b) a cut having a distillation range of not over 5° C from over-point to dry-point with 10-90% within 2° C. Table X contains boiling-point, density, and refractive index data on relatively wide cuts.

The Gladstone and Dale specific refraction and the Refractivity Intercept [16, 1936] have been given in this table since these constants are helpful in evaluating the nature of a naphtha. Table XI gives average values for these constants for the various groups of hydrocarbons. It will be seen that saturated cyclic compounds have the lowest specific refraction and refractivity intercept. If a straight-run naphtha with high density is being examined, either of these constants may be used to determine whether the high density is caused by saturated cyclic or aromatic

PHYSICAL AND CHEMICAL PROPERTIES

TABLE X
Density and Refractive Index of Gasoline and Kerosine
Gasoline — over at 20° C, Kerosine — 200–300° C

Description and reference number		Boiling range, ° C	d_{4}^{20} at 60° F	d_{4}^{20} ° C	n_{D}^{20} ° C	$n - 1$ d	$n - d/2$
Naphtha from Venezuela gas oil by Gyro process	Cuts	75–100	60.3	0.7334	1.4177	0.570	1.051
	"	100–25	51.4	0.7693	1.4362	0.567	1.052
	"	125–50	47.6	0.7852	1.4433	0.564	1.050
	"	150–75	44.5	0.8001	1.4501	0.563	1.050
	"	175–200	39.5	0.8231	1.4621	0.561	1.051
Ref [6]	Average*	100–200	45.7	0.7947	1.4479	0.564	1.051
Iranian	Cuts	75–100	64.0	0.7191	1.404	0.562	1.045
	"	100–25	58.6	0.7401	1.415	0.561	1.045
	"	125–50	53.8	0.7595	1.426	0.561	1.046
	"	150–75	49.8	0.7764	1.436	0.562	1.048
	"	175–200	46.7	0.7898	1.444	0.560	1.049
Ref [18, 1930]	Average*	100–200	52.1	0.7664	1.430	0.561	1.047
*Pure paraffin naphtha obtained by cracking 141° F m p Burma wax and acid treating	Cuts	70–100	80.3	0.663	1.3793	0.572	1.047
	"	100–50	66.6	0.710	1.3982	0.561	1.043
	"	150–200	59.2	0.738	1.4134	0.560	1.044
	"	200–50	53.7	0.760	1.4250	0.559	1.045
	"	250–80	49.9	0.776	1.4336	0.560	1.046
Ref [22, 1928]†	Average*	100–200	62.9	0.724	1.4058	0.560	1.044
"	"	70–280	61.5	0.729	1.4099	0.562	1.045
Venezuelan	Cuts	75–100	64.4	0.7177	1.401	0.559	1.042
	"	100–25	58.9	0.7391	1.413	0.559	1.044
	"	125–50	53.5	0.7608	1.425	0.559	1.045
	"	150–75	48.8	0.7808	1.435	0.557	1.045
	"	175–200	43.4	0.8050	1.448	0.556	1.046
Ref [18, 1932]	Average*	100–200	50.9	0.7714	1.430	0.558	1.044
Pennsylvania Average of four samples from different wells	Cuts	Over 100	75.7	0.678	1.383	0.565	1.044
	"	100–50	59.7	0.736	1.410	0.556	1.042
	"	150–200	52.0	0.767	1.427	0.556	1.044
	"	200–50	46.9	0.789	1.439	0.556	1.045
	"	250–300	42.3	0.810	1.450	0.555	1.045
"	Average*	200–300	44.7	0.799	1.444	0.555	1.044
Ref [25, 1915]‡	"	100–200	56.2	0.751	1.418	0.556	1.043
	"	Over 200	62.1	0.727	1.407	0.559	1.044
	"	"	"	"	"	"	"
Oklahoma Average of five samples from different wells	Cuts	Over 100	73.3	0.686	1.387	0.564	1.044
	"	100–50	56.7	0.748	1.417	0.558	1.043
	"	150–200	48.7	0.781	1.433	0.554	1.043
	"	200–50	42.1	0.811	1.449	0.554	1.044
	"	250–300	38.2	0.830	1.460	0.554	1.045
"	Average*	200–300	40.2	0.820	1.454	0.554	1.044
Ref [25, 1915]	"	100–200	52.7	0.764	1.425	0.556	1.043
	"	Over 200	59.2	0.738	1.412	0.557	1.043
	"	"	"	"	"	"	"
Mexican One sample	Cuts	100–50	55.2	0.754	1.419	0.556	1.042
	"	150–200	45.8	0.794	1.439	0.553	1.042
	"	200–50	36.6	0.838	1.464	0.556	1.045
	"	250–300	31.0	0.867	1.481	0.555	1.048
	"	Average*	200–300	33.8	0.852	1.472	0.555
Ref [25, 1915]	"	100–200	50.3	0.774	1.429	0.555	1.042
	"	"	"	"	"	"	"
	"	"	"	"	"	"	"
California Ventura County, one sample	Cuts	Over 100	73.6	0.685	1.386	0.564	1.044
	"	100–50	55.7	0.752	1.418	0.556	1.042
	"	150–200	46.9	0.789	1.436	0.553	1.042
	"	200–50	40.0	0.821	1.455	0.554	1.045
	"	250–300	34.0	0.850	1.472	0.555	1.047
"	Average*	200–300	37.1	0.835	1.463	0.555	1.045
Ref [25, 1915]	"	100–200	51.3	0.770	1.427	0.555	1.042
	"	0–200	58.2	0.742	1.413	0.555	1.042
	"	"	"	"	"	"	"
Miri British Borneo	Cuts	75–100	55.2	0.7537	1.418	0.555	1.041
	"	100–25	53.1	0.7624	1.423	0.554	1.042
	"	125–50	48.8	0.7808	1.432	0.554	1.041
	"	150–75	44.1	0.8017	1.443	0.554	1.042
	"	175–200	39.3	0.8246	1.455	0.554	1.043
Ref [18, 1932]†	Average*	100–200	46.2	0.7924	1.438	0.553	1.042

* Averaged on basis of equal volumes for each cut given in original reference

† These references contain discussions of physical properties and much additional data

‡ Reference [25, 1915] contains molecular weight and surface tension on all cuts.

TABLE X (cont)

Description and reference number		Boiling range, °C	ΔAP at 60° F	$d_{4}^{20}, \text{g./cc.}$	$n_D^{20}, \text{c.}$	$n-1/d$	$n-d/2$
Russum	Cuts	Over 100	61.8	0.728	1.402	0.552	1.038
Two samples	"	100-50	52.7	0.764	1.422	0.552	1.040
"	"	150-200	44.5	0.800	1.440	0.550	1.040
"	"	200-50	38.0	0.831	1.457	0.550	1.041
"	"	250-300	32.8	0.857	1.473	0.552	1.045
	Average*	200-300	35.3	0.844	1.465	0.551	1.043
Ref [25, 1915]	"	100-200	48.5	0.782	1.431	0.551	1.040
"	"	Over 200	52.7	0.764	1.421	0.551	1.039
California Kern County, Bear Creek no 3	Cuts	150-200	40.0	0.821	1.448	0.546	1.037
"	"	200-50	33.2	0.855	1.465	0.544	1.037
"	"	250-300	27.5	0.886	1.484	0.546	1.041
	Average*	200-300	30.4	0.870	1.474	0.545	1.039
Badarpur	Cuts	150 $\frac{1}{2}$	44.4	0.8006	1.434	0.542	1.034
"	"	175 $\frac{1}{2}$	38.6	0.8280	1.447	0.540	1.033
"	"	200 $\frac{1}{2}$	32.9	0.8568	1.461	0.538	1.033
Ref [2, 1928]†	"	225 $\frac{1}{2}$	28.0	0.8832	1.477	0.540	1.035
Badarpur crude (Assam, India)	Cuts	150-200	44.3	0.805	1.4396	0.546	1.037
"	"	200-50	31.3	0.865	1.4663	0.539	1.034
"	"	250-80	26.9	0.889	1.4785	0.540	1.034
	Average*	150-280	34.7	0.847	1.4588	0.542	1.035

* Spot values from curves of properties vs boiling-point, see Table VI and Figs 4 and 5 in reference [2, 1928]

compounds. Inspection of Table X brings out the point that all the straight-run naphthas have specific refractions and refractivity intercepts equal to or lower than the value for paraffins. Therefore, the predominating type of high-density compound in naturally occurring naphthas must be saturated cyclic and not aromatic. The work of the Bureau of Standards on straight-run naphthas from Oklahoma crude [19, 1935] confirms this, since they found 60% paraffins, 30% saturated cyclics, and 10% aromatics.

TABLE XI

Average Constants Characteristic of Homologous Series

	Refractivity intercept* $= n-d/2$	G and D specific refractant† $= (n-1)/d$
Paraffins	1.046	0.565
Saturated monocyclics	1.040	0.548
" polycyclics	1.028	
Aromatics	1.063	0.573
" Mono-olefines	1.052	0.579
Unconjugated diolefines	1.059	
Conjugated "	1.088	0.621
Cyclic mono-olefines	1.046	0.553
" conjugated diolefines	1.064	0.569

* Based on pure compound tables of Ward and Kurtz (to be published)

† Based on a smaller tabulation of pure compounds data

References to naturally occurring aromatic naphthas which sometimes appear in the literature should be carefully checked, since they usually are based on insufficient or inaccurate data.

The refractivity intercept is given in addition to the Gladstone and Dale specific refraction because refractivity intercept is a convenient and useful constant for comparing homologous series of hydrocarbons. The Lorentz-Lorentz specific refraction is not so useful for this purpose unless the boiling-point and molecular weight are taken into account as well as the density and refractive index. Refractive dispersion and specific refractive dispersion [31, 1934] may also be used for comparison of homologous

series of hydrocarbons when such data are available. Specific dispersion is especially useful in identifying aromatic compounds.

If the refractive index and density data in Table X are plotted in the manner of Lang and Jessel [18, 1932], one obtains confirmation of their observations (1) that the cuts of each naphtha fall on a straight line, (2) that all the naphthas do not fall on the same straight line.

Each curve represents practically a constant refractivity intercept characteristic of the naphtha, as discussed elsewhere [16, 1936]. If narrow cuts are taken with good fractionation, these straight lines are broken up into curves having several maxima and minima because of concentration of a particular type of compound in a particular cut. For characterizing the naphtha in regard to general type, data on broad cuts (containing a representative mixture of compounds) are, therefore, more useful than data on very narrow cuts. Data on narrow cuts are only justified when a very complete analysis is to be made.

Refractive index and density are frequently of value in identifying the type of compounds in narrow cuts. The Bureau of Standards in its work [19, 1935] used refractive index in following the progress of its various laborious separations. Two actual examples of the use of these two constants in identifying the type of compound in a narrow cut are as follows.

Example 1. A California gasoline on fractionation yielded a narrow cut having the following properties: b_p 79.2° C, $d_4^{20} = 0.7378$, $n_D^{20} = 1.4091$. With the same conditions of fractionation a Pennsylvania gasoline gave a cut having (approximately) the following properties: b_p 80° C, $d_4^{20} = 0.700$, $n_D^{20} = 1.393$. It is clear that the California gasoline contains material of high density and refractive index, which may be either cyclohexane or benzene. The refractivity intercept of the California cut is 1.0401, the Gladstone and Dale specific refraction is 0.5545. Inspection of Table XI shows that this material is intermediate between naphthenes and paraffins, therefore its high specific gravity is due to saturated cyclic compounds.

Example 2. A sample of high-flash aviation fuel from

a hydrogenation plant yielded cuts of which the following is typical in regard to quality 50% b.p. = 185° C., $d_{4}^{20} = 0.8718$, $n_D^{20} = 1.5020$ Refractivity intercept = 1.066, the specific refraction of Gladstone and Dale = 0.5758 Inspection of Table XI shows that this sample contains aromatic material

Gas Oils and Fuel Oils.

Although neither gas nor fuel oils are to-day sold on a gravity specification, gravity is an important criterion of the quality of the oil Its interpretation, however, depends

A P I gravity for a given boiling range generally indicates a refractory oil, it generally indicates a low carburetting or enriching value The subject, already a complex one, has become more complicated in recent years with the introduction of the use of heavy fuel oils in the carburetion of blue gas

The significance of gravity in connexion with Diesel fuels is somewhat similar to its significance in the case of gas oils, the higher the A P I gravity (the lower the specific gravity) for any boiling range the more paraffinic the oil and the better the ignition in a Diesel engine

TABLE XII
Gas Oil Characteristics [3, 1936]

Table XII shows the characteristics of samples of gas oil from a number of different fields

Field	A	B	C	D	E	F	G	H	I	J	K
Grav API	36.0	34.2	33.3	30.4	40.3	32.7	28.8	29.1	20.8	24.6	26.1
Sp gr 60°/60° F	0.8448	0.8540	0.8586	0.8740	0.8236	0.8618	0.8827	0.8811	0.9291	0.9068	0.8976
n 60° F/D	1.4673	1.4700	1.4660	1.4727	1.4855	1.4790	1.4837	1.4892	1.500	1.497	1.493
% Coke	0.31	0.23	0.28	0.10	0.35	0.30	0.74	0.66	4.2	1.3	3.5
% Sulphur	0.18	0.35	0.38	0.24	0.20	2.51	3.18	2.12	1.01	0.45	0.55
Distillation											
Up to 400° F			8.7	4.0			1.8			1.5	5.2
400-450		11.5	28.0	15.3	1.4	0.5	6.7	1.5	3.0	4.6	2.4
500-550	2.8	27.8	32.5	21.7	10.6	41.5	13.0	5.0	8.1	12.9	4.4
550-600	31.3	28.0	17.0	24.5	38.2	28.5	20.0	30.0	9.6	14.0	6.0
600-650	58.6	20.5	8.5	17.3	28.0	15.5	18.2	28.0	11.5	14.2	8.4
650-700	6.0	10.8	3.0	10.3	14.5	7.5	25.0	22.2	20.8	19.4	15.0
Above 700			2.0	6.8	6.0	2.5	15.0	12.5	39.9	13.3	32.0
Sp gr frac 60°/60° F											
Up to 400° F				0.8114			0.8241				
400-450				0.8318			0.8328				
450-500		0.8276	0.8264	0.8441	0.8395	0.8474	0.8427	0.8469			
500-550	0.8156	0.8481	0.8418	0.8441	0.8583	0.8629	0.8636	0.8651			
550-600	0.8402	0.8577	0.8524	0.8583	0.8722	0.8718	0.8851	0.8814			
600-650	0.8532	0.8714	0.8774	0.8790	0.8722	0.8851	0.8970	0.8968			
650-700	0.8745	0.8836	0.8978	0.8869	0.8957	0.8961	0.9053	0.9145			
Above 700			0.9050	0.8969	0.9066						
Refractive index n											
60° F											
Up to 400° F				1.4488			1.4529			1.4645	1.4245
400-450				1.4622		1.4710	1.4616		1.4746	1.4742	1.4552
450-500		1.4596	1.4677	1.4610	1.4703	1.4764	1.4797	1.4750	1.4835	1.4813	1.4660
500-550	1.4663	1.4741	1.4679	1.4775	1.4774	1.4810	1.4809	1.4822	1.4919	1.4889	1.4725
550-600	1.4712	1.4804	1.4748	1.4828	1.4861	1.4864	1.4892	1.4886	1.4979	1.4940	1.4794
600-650	1.4845	1.4900	1.4828	1.4882	1.4920	1.4928	1.4978	1.4972	1.5041	1.4997	1.4885
650-700			1.4918	1.4857	1.5096	1.4958	1.5037	1.5090	1.5031	1.5036	1.4988
Above 700											

A Pennsylvania
B Mid-Continent
C Gulf Coast
D Texas
E Cracked Mid-Continent
F Light Mexican

G Heavy Mexican
H Cracked Mexican
I
J Heavy Gas Oils
K

entirely upon the use to which the oil is to be put Speaking generally, it may be stated that, other things being equal, the lower the A P I gravity (the higher the density) of an oil the greater the heating value in B Th U per gallon Therefore, if an oil is to be used for heating purposes, the higher the density (the lower the A P I gravity) the better, providing, of course, that the oil is suitable in viscosity and other properties for the burner in which it is to be used

On the other hand, if the oil is to be cracked, for example, if it is to be used for the carburetion of blue gas, the interpretation of gravity is directly opposite to that when the oil is to be used for heating purposes In the carburetion of blue gas the criterion is not the B Th U in the oil but the B Th.U in the oil gas made from it Since in general a low

Gas Oils.

The gravity and refractive index and certain other properties of eleven gas oils are given in Table XII Gas oil A is representative of Pennsylvania grade gas oil which was formerly almost standard in the industry, but which is now too valuable for other purposes to be used for gas enrichment Samples G, H, I, J, and K represent the heavy gas oils which are now coming into general use

The shift towards high-boiling low A P I gravity enrichment oils is entirely dictated by price, since as shown in Table XIII there is less enrichment value per gallon in the heavy oils than in the light oils Data such as that in Table XIII have frequently led to attempts to set up a

TABLE XVI
Motor Manufacturers' Recommendations for Viscosity and Gravity of Diesel Fuels

Motor speed, revolutions per minute	Number of specifications averaged	Viscosity (Saybolt Units at 100° F)		Gravity API at 60	
		Min	Max	Min	Max
		Above 1,000 (High-speed Diesel)	19	Average 36 Lower limit 30	78 40
500 to 1,000 (Medium-speed Diesel)	18	Upper " 40 Lower limit 30	200 45	31 16	45 34
Below 500 (Low-speed Diesel)	23	Average 41 Lower limit 30	75 55	26 14	38 19
		Upper " 75	200 210	31 30	45 45

reference compound, the work of Moore and Kaye requires some revision, but this will not affect the established relation between viscosity-gravity constant and Diesel ignition quality given in Table XVI.

The distillation range on these fuels is 450° to 700° F. These authors state, "In general the higher the A P I Gravity (ρ the lower the density) for a given distillation range, the better the ignition quality of a fuel."

It is probable that the viscosity-gravity constant will be very extensively used in classifying Diesel fuels because it may be easily derived from test data which are usually obtained, and because it seems to be reasonably reliable.

REFERENCES

- American Society for Testing Materials *Proceedings* (340), 1935, Report of Committee C, Section D-2
- CARPENTER, J A *J I P T* 14, 470 (1928)
- Data supplied by United Gas Improvement Company, Phila., Pa
- FENSKÉ, M R *Ind Eng Chem* 22, 913 (1930)
- FENSKÉ, M R, QUIGG, D, and TONARRO, C *Ind Eng Chem* 24, 542 (1932)
- FERRIS, S W Data courtesy of S W Ferris and Atlantic Refining Company
- FINLEY, G H *Handbook of Butane-Propane Gas* (2nd ed 1935, Western Business Papers, Inc., Los Angeles, Cal)
- GURWITZCH, L, and MOORE, H *The Scientific Principles of Petroleum Technology*, 7 (Chapman and Hall, London, 1926)
- HENDERSON, L M, and FERRIS, S W U S P 1,868,102 (19 July 1932) Assigned to Atlantic Refining Company
- HILL, J B, HENDERSON, L M, and FERRIS, S W *Ind Eng Chem* 19, 128 (1927)
- HOLMES, A *Ind Eng Chem* 24, 325 (1932)
- HOUGHTON, W F, and ROBB, J A *Ind Eng Chem, Anal Ed* 3, 144 (1931)
- HUNNER, W H, and MURPHY, G B *Nat Petr News*, 27, 240-33 (1935)
- International Critical Tables*, 2, 153 (1927)
- JACKSON, E A *Oil and Gas J* 33 (44) (1935)
- KURTZ, S S, Jr., and WARD, A L *J Franklin Inst* 221, 563 (1936)
- LANE, E C, and GARTON, E L *U S Bureau Mines Rept Invest*, 3279, p 935 (1935)
- LANG, H R, and JESSEL, R *J I P T* 16, 807 (1930), 17, 572 (1931), 18, 850 (1932)
- LESLIE, R T, and WHITE, J D *U S Bur Stds J Res* 15, 211 (1935)
- MACFARLANE, W, and WRIGHT, R *J C S* 114, Feb (1933)
- MINCHIN, S T *J I P T* 17, 104 (1931)
- MINCHIN, S T, and NIXON, G R *J I P T* 14, 477 (1928)
- MOORE, C C, Jr., and KAYE, G R *Proc A P I* 15, Sect III, p 7 (Nov 1934)
- POHLMAN, E F *Proc Amer Gas Assoc* 1193 (1930)
- RITTMAN, W F, and ECKLOFF, G *Ind Eng Chem* 7, 482 (1915)
- ROBBIN, F D A P I Meeting Div of Refining 47, (15 May 1935)
- SCHAFFHAUSER, S *Über die Bewertung von Karburisierölen*, Thesis Zurich Technischen Hochschule (1933)
- SMITH, N A C, and LANE, E C *U S Bur Mines Bull* 291 (U S Govt Printing Office, Washington, D C, 1928)
- TERZIAN, H G Paper delivered before Prod Conf Amer Gas Assoc (1936)
- THEILE, E W, and KAYE, W *Ind Eng Chem* 25, 894 (1933)
- WARD, A L, and FULWELER, W H *Ind Eng Chem, Anal Ed* 6, 396 (1934)
- WASHBURN, E W *Ind Eng Chem* 25, 891 (1933)
- Oil and Gas J* 19 Dec (1935)

ARTICLES

- DOCKREY, P Viscosity-Gravity Constant
- WARD, et al General Relationship of Density Refractive Index and Related Characteristics with Structure of Hydrocarbons

DENSITY AND REFRACTIVE INDEX OF PARAFFIN WAX

By A. L. WARD, Manager, The Chemical Laboratories, The United Gas Improvement Company, S. S. KURTZ, Jr., Development Engineer, The Sun Oil Company, W. H. FULWEILER, Consulting Chemical Engineer

'PARAFFIN WAX' is a term which lacks precise definition. The higher boiling cuts of petroleum contain many compounds capable of crystallization but of widely varying solubility in heavy oil and other solvents. In any dewaxing operation the more insoluble, and higher melting, waxes are removed. By repeating the dewaxing operation at a lower temperature more crystalline products can be obtained, but these products, though crystalline under the dewaxing conditions, may be liquid at room temperature. No satisfactory definition has been agreed upon for classifying these low-melting waxes.

Customary usage limits the term 'wax' to materials which are crystalline at room temperature, but this usage is not very satisfactory or precise. This lack of a good criterion by which borderline materials can be classified must be borne in mind in considering various methods of determining 'oil' and 'wax'. These borderline materials in general are responsible for the difference between analytical results obtained by (a) press methods, (b) solvent methods, and (c) density and refractive index methods.

(a) Wax Density, Temperature Corrections, and Accounting Practice.

The fact that wax crystallizes at ordinary temperatures makes it necessary to consider the density and coefficient of expansion of wax both in the liquid and solid state [10, 1936]. Table I gives a portion of the excellent data of Carpenter [1, 1926], and Table II gives unpublished data of Soeder and Geggus [7]. The data of Carpenter and Soeder are for air-free wax, while the data of Geggus were obtained with wax containing the usual amount of air. All these data when plotted show that in the liquid state the expansion of wax corresponds with that given in the National Standard Petroleum Tables for an oil of 43° API gravity at 60° F. For waxes in the liquid state the usual petroleum tables may be used. For most purposes the following coefficients calculated for 43° API oil for the temperature range 20 to 80° C will be found sufficiently accurate:

- Temp. correction for specific gravity $t/60$
 = $0.00037^{\circ} F$ or $0.00067^{\circ} C$
 " " API gravity
 = $0.085^{\circ} F$ or $0.153^{\circ} C$
 " " volume (ml/ml^o)
 = $0.00049^{\circ} F$ or $0.00089^{\circ} C$
 " " multiplier ($V 60^{\circ} F / V t^{\circ} F$)
 = $0.00047^{\circ} F$ or $0.00085^{\circ} C$

This Multiplier is defined in the A S T M Standard Volume Correction Table.

It should be noted that when using the abridged volume correction tables (A S T M Proceedings, D 206-34) wax will fall in Group II, whereas paraffin distillate will fall in Group I. In refinery inventory and accounting practice it is desirable to take hydrometer gravities on the liquid wax and correct to 60° F. In the usual manner, ignoring the fact that the wax crystallized, this system consistently used introduces no errors in material balances. For wax of 120 to 132° F (49 to 56° C) melting-point, the following factors

may be used for the hypothetical liquid wax at 60° F. 43° API, 6.75 lb per gal, 6.64 bbl per ton for 50-gal bbl and tons of 2,240 lb. Since barrels of wax can only be filled while the wax is in the liquid state, the liquid gravity

TABLE I
Coefficient of Expansion and Density of Wax
According to J. A. Carpenter [1, 1926]

Description	Range, °C	Condition	Avg coef expansion per °C over range	Cumulative % volume increase	Density, g per ml at upper temp limit
Refined fields wax m p + 90° C (Burma crude)	0-30	solid	0.0001	0.0	0.9112
	30-40	"	0.0003	0.3	0.9066
	40-50	"	0.0010	0.6	0.9060
	50-60	"	0.0013	1.6	0.8970
	60-70	"	0.0017	2.9	0.8856
	70-5	"	0.0021	4.6	0.8712
	75-30	"	0.0033	7.3	0.8621
	80-5	"	0.0055	10.0	0.8284
	85-30	"	0.0077	13.9	0.7999
	90-1	"	0.0149	17.4	0.7769
Recrystallized wax m p + 65° C (Burma crude)	0-30	solid	0.0010	0.0	0.9256
	30-50	"	0.0010	3.0	0.8986
	50-2	"	0.0039	5.3	0.8815
	52-5	"	0.0039	6.5	0.8790
	55-6	"	0.0090	7.4	0.8691
	56-4	"	0.0043	8.2	0.8618
	58-41	"	0.0048	9.1	0.8534
	61-3	"	0.0063	10.3	0.8484
	63-5	"	0.0097	12.3	0.8390
	65-6	melting liquid	0.0070	18.0	0.8242
An American refined wax m p + 56° C	0-20	solid	0.0010	0.0	0.9327
	20-30	"	0.0013	3.3	0.9145
	30-2	"	0.0013	3.6	0.9005
	32-5	"	0.0027	4.4	0.8932
	35-7	"	0.0029	5.0	0.8882
	37-40	"	0.0042	6.3	0.8775
	40-3	"	0.0022	7.4	0.8684
	45-30	"	0.0020	8.4	0.8606
	50-5	"	0.0074	12.1	0.8320
	55-7	melting liquid	0.0367	19.4	0.7810
Once recrystallized fraction m p + 44° C (Burma crude)	0-10	solid	0.0011	0.0	0.9258
	10-15	"	0.0014	1.1	0.9168
	15-16	"	0.0017	2.0	0.9087
	16-20	"	0.0051	4.0	0.8911
	20-2	"	0.0034	4.7	0.8852
	22-6	"	0.0018	5.4	0.8786
	25-30	"	0.0031	6.4	0.8695
	30-3	"	0.0016	7.1	0.8652
	33-5	"	0.0021	7.5	0.8622
	35-7	"	0.0045	8.4	0.8550
Oils	37-41	"	0.0023	9.8	0.8441
	41-4	"	0.0120	13.4	0.8174
	44-5	melting liquid	0.0519	18.5	0.7821
	45-50	"	0.0010	19.0	0.7790
	50-60	"	0.0010	20.0	0.7724
	60-70	"	0.0010	21.0	0.7652
	70-100	"	0.0010	24.0	0.7465

at the filling temperature must be used in calculating the actual weight of wax which can be shipped in a barrel.

The actual specific gravity 60/60° F of 120 to 132° F. m p wax is about 0.90 to 0.92, compared with 0.81 as the

PHYSICAL AND CHEMICAL PROPERTIES

specific gravity in the hypothetical liquid state at that temperature. Table III gives further data on wax densities.

The coefficient of expansion of solid wax is usually in the range 0.001 to 0.005 cc/cc/°C [7, 1926], and according to the data of Carpenter (q v) shows distinct maxima below the melting-point. Coefficient of expansion data of accuracy comparable to Carpenter's have not yet been obtained for waxes purified by prolonged [5, 1931] fractional crystallization, therefore it is possible that these maxima are the result of the presence of several types of

wax in Carpenter's samples, rather than of the presence of true transitions from one solid state to another solid state.

(b) **Refractive Index of Wax and Temperature Corrections.**

Refractive index data for wax in the solid state are not given in this section. Since waxes are high melting, their refractive indices are usually determined at elevated temperatures, such as 60°C (140°F) or 80°C (176°F), but Wilson and Wilkins [13, 1924] report refractive indices on

TABLE II
Density of Paraffin Wax
Atlantic Refining Company Data [12]

	Temperature		118-22° F m p		122-7° F m p		130-4° F m p	
	° F	° C	Density, lb per gal	Density, g per ml	Density, lb per gal	Density, g per ml	Density, lb per gal	Density, g per ml
Fully refined wax, not air free (Geggs)	60	15.56	7.47	0.896	7.49	0.899	7.52	0.902
	130	34.4	6.52	0.782	6.54	0.784	6.57	0.789
	150	65.6	6.46	0.775	6.47	0.777	6.48	0.778
	170	76.7	6.40	0.768	6.41	0.769	6.43	0.771
	200	93.3	6.33	0.760	6.35	0.762	6.35	0.761
Refined wax, air free, 120.5 m p and 127.5 m p respectively (Soeder)	60	15.56	7.56	0.907	7.54	0.905		
	78	25.5			7.51	0.906		
	82	28.2	7.36	0.883				
	90	32.2	7.28	0.873	7.37	0.885		
	100	38.2	7.24	0.869				
	105	40.6			7.25	0.869		
	110	43.3	7.15	0.857				
	114	45.6	7.08	0.849				
	120	48.9			7.08	0.849		
	122	50.0	6.53	0.783				
	125	51.6	6.52	0.782				
	130	54.4	6.51	0.781	6.52	0.783		
	132	55.6			6.51	0.781		
	134	56.6			6.51	0.781		
	140	60.0	6.48	0.777	6.49	0.778		
150	65.6	6.45	0.774	6.46	0.775			
160	71.0	6.42	0.770	6.43	0.771			
170	76.7	6.39	0.767					
180	82.2	6.37	0.764					

TABLE III
Density of Paraffin Wax
Data of Morris and Adkins and of Gurwitsch

Experimenters	Melting-point		Solid wax		Liquid wax	Hypothetical liquid calc from 130° F	
	° C	° F	d_{20}^{20}	d_{20}^{20}	d_{20}^{20}	d_{20}^{20}	d_{20}^{20}
Morris and Adkins American wax Ref [9, 1927]	39	103	0.876	0.8801	0.778	0.801	0.805
	43	109	0.880	0.8842	0.777	0.800	0.804
	46	115	0.892	0.8964	0.780	0.803	0.807
	48	118	0.901	0.9053	0.782	0.805	0.809
	51	123	0.903	0.9068	0.784	0.807	0.811
53	127	0.916	0.920				
Gurwitsch Galacian wax Ref [7, 1926]	56	133	0.911	0.915			
	61	142	0.921	0.925			
	67	153	0.926	0.930			
	72	162	0.934	0.938			
	76	169	0.938	0.942			
	82	180	0.942	0.946			

liquid wax at 25° C by determining the refractive index of a solution of wax in an oil of known refractive index. It is pointed out in the article on the 'Determination of Density and Refractive Index of Pure Hydrocarbons and Petroleum Products' that (1) the change in refractive index for hydrocarbons may be calculated from Eykman's formula if the change of density is known, and (2) that $\Delta n = K\Delta d$, where $K = 0.58$ to 0.60 . Calculating from Eykman's equation for the temperature range 20 to 80° C, it was found that the change should be 0.00040° C (or 0.00022° F), which checks reasonably well with the value of 0.00038° C (0.00021° F) obtained from Williams and Wilkins' graph for the range 110 to 210° F. For the purpose of comparing wax refractive indices with data for pure compounds at 20° C one can correct from 80 to 20° C, using 0.00040° C for the refractive index correction and 0.00067° C for the density correction. These corrections when used below the melting-point of the wax refer to the hypothetical super-cooled liquid state. Correction of data for plate-type waxes 5-A and 6-A of Ferris, Cowles, and Henderson [4, 1929, 5, 1931] to 20° C leads to refractivity intercepts of 1.0486 and 1.0491 respectively, which are reasonable values for paraffins of this molecular weight.

(c) Analysis of Oil-wax Mixtures.

The suggestion has frequently been made [2, 1927, 6, 1931, 11, 1930, 13, 1924] that the refractive index is suitable for the analysis of oil-wax mixtures. The use of the refractive index for analysis is apparently practical in refineries which are operating for long periods on one crude oil, so that the refractive indices of the finished wax and of the pressed distillate do remain relatively constant. Freund [6, 1931] has shown this constancy over several years' running of Boryslawer paraffin distillate to obtain wax of 51.5 to 53.5° C m.p., and states that the refractive index analysis has been found satisfactory for plant control. Table IV shows the data of several experimenters for the refractive index of pressed distillate and refined wax. Diggs and Buchler [2, 1927] in discussing plant control recommend redetermination of the refractive index of oil-free wax once a month. The oil-free wax may be prepared by crystallization from ethylene dichloride [13, 1924], even though this does involve the loss of low-melting waxes. It is claimed by Diggs and Buchler that their method is reproducible within a few tenths of a per cent., and that the absolute accuracy is within 1%. As discussed in the introduction, the question of the determination of oil in wax has been complicated by the lack of a sharp dividing line between oils and waxes and the lack of any satisfactory definitions which can be used to classify the borderline materials. The work of Ferris [5, 1931] and his collaborators has shown that there are plate, mal-crystal, and needle-type waxes of identical molecular weight, but of widely differing melting-point and solubility [4, 1929]. Many of the low-melting waxes remain in the pressed distillate because they are soluble at the temperature of pressing.

The present situation is that there are several rather arbitrary ways of determining oil in wax and that the refractive index method, if carefully used and interpreted, is probably as good as any of them. It is not to be expected

TABLE IV
Refractive Index of Pressed Distillate and Refined Wax

Ref	Temp ° C	Pressed dist n_D^{20}	Wax		Δn_D^{20}
			m.p. ° C	n_D^{20}	
[13, 1924]	25	1.4885	1.447*	0.0415	
[2, 1927]	60	1.4762	1.4342	0.0420	
[6, 1931]	56.3†	1.4842‡	51.5	1.4370	0.0472
"	"	1.4847‡	51.5	1.4372	0.0475

* Determined in oil solution

† Boiling acetone for temperature control

‡ Melting-point of filtrate oil -1 to +3° C

that the various methods will check each other, since there is no definite understanding of where oil stops and wax begins.

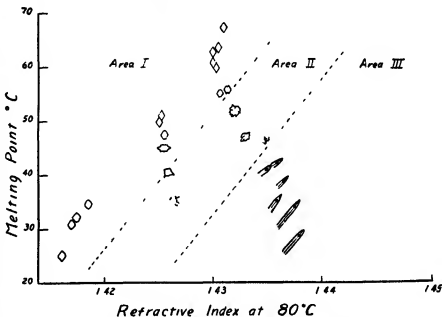

FIG. 1 Melting-point v refractive index at 80° C for wax.

(d) Classification of Special Waxes.

The work of Ferris, Cowles, and Henderson on the separation of relatively pure-type waxes by fractional distillation and systematic crystallization has shown that at least three definite types of wax may be separated from paraffin distillate of Mid-Continent crude. Data for these waxes are given in Table V. These are plate, mal-crystal, and needle waxes, which in the pure state crystallize only in the characteristic form, whether crystallized from their own melt or from any solvent, irrespective of viscosity, concentration, &c. Fig. 1 shows the melting-point plotted against refractive index at 80° C. Waxes falling in area I are plates, waxes falling in area II do not form clean-cut crystals of any type, waxes in area III form needle crystals. Refractive index and melting-point are, therefore, suitable properties for use in classifying highly purified paraffin waxes.

TABLE V
Properties of Highly Purified Wax Fractions

Ref	Sample no	m p ° C	Density d ₄ ²⁰	Ref index n _D ²⁰	Mol wt	Boiling- point, ° C 10 mm	Type
[5, 1931]	1	25.1	0.7466	1.4161	263	172	
	2	30.8	0.7450	1.4170	261	180	
	3	32.1	0.7464	1.4175	274	183	plate
	4	34.6	0.7475	1.4185	276	188.5	
	5 A	51.0	0.7606	1.4252	341	236	plate
	5 B	49.9	0.7606	1.4250	341	236	"
	5 C	47.3	0.7625	1.4255	333	234	"
	5 D	44.9	0.7612	1.4254	336	233.5	"
	5 E	40.2	0.7624	1.4258	334	235.5	mal-crystal
	5 F	35.1	0.7692	1.4273	344	236	"
	6 A	65.5	0.7717	1.4310	420.5	291	plate "
	6 B	63.6	0.7711	1.4305	409	282.5	"
	6 C	62.8	0.7703	1.4301	407	278.5	"
6 D	60.8	0.7706	1.4300	400	275	"	
6 T	55.8	0.7728	1.4313	402.5	275	"	
6 t	50.9		1.4332	409.5	276	mal-crystal	
6 G	46.3	0.7819	1.4349	407	283	"	
6 H	42.1	0.7841	1.4359	401	284	needle "	
6 I	38.8	0.7876	1.4365	410	287	"	
6 J	34.0	0.7889	1.4375	402	281.5	"	
[4, 1929]	A	59.9	0.770	1.4303	366	269.5	plate
	B	55.2	0.773	1.4306	367	269.5	"
	C	47.1	0.779	1.4330	379	272.5	mal-crystal
	D	40.5	0.783	1.4350	389	272	needle
	E	35.2	0.786	1.4359	385	272	"
	F	29.4	0.792	1.4380	377	273.5	"

TABLE VI
Data of Eykman [3, 1896] obtained on Pure Paraffins
of Kraft

Formula and mol wt	Temp ° C	Density d ₄ ²⁰ (vac)	Refractive indices (vac) at indicated temperatures			
			Hβ	D*	H _α	
C ₁₈ H ₃₈ 324	81.6	0.7577	1.42882	1.4237	1.42150	
	48.95	0.7788	1.44167	1.4363	1.4341	
C ₁₉ H ₄₀ 310	78.85	0.7560	1.42818	1.4230	1.42084	
	80.9	0.7548	1.42749	1.4224	1.42015	
	46.9	0.7769	1.44091	1.4355	1.43332	
C ₂₀ H ₄₂ 296	80.9	0.7522	1.42604	1.4210	1.41877	
	49.5	0.7729	1.43841	1.4331	1.43087	
C ₂₁ H ₄₄ 282	79.3	0.7499	1.42486	1.4197	1.41763	
	45.6	0.7721	1.43835	1.4330	1.43083	
C ₂₂ H ₄₆ 268	81.9	0.7451	1.42225	1.4171	1.41501	
	34.6	0.7766	1.44133	1.4360	1.43378	
C ₂₃ H ₄₈ 254	81.2	0.7409	1.42000	1.4149	1.41278	
	80.95	0.7411	1.42022	1.4152	1.41307	
	35.2	0.7720	1.43897	1.4337	1.43147	
C ₂₄ H ₅₀ 240	80.85	0.7379	1.41852	1.4134	1.41128	

* Interpolated by means of Cauchy formula from Eykman's data

The plate-type waxes are by all indications approximately straight-chain paraffin hydrocarbons. Data of Eykman [3, 1896] obtained on Kraft's normal paraffin hydrocarbons are presented in Table VI for the convenience of any one wishing to compare the properties of purified waxes with the properties of the normal straight-chain compounds.

(e) Miscellaneous Data.

Table VII gives refractive index and melting-point data for various American and foreign waxes.

TABLE VII
Refractive Index and Melting-point of Waxes and Wax
Fractions

Reference	m p ° C	Refractive Index n _D ²⁰	Wt % of original	t ° C	Comments	
[1, 1927]	56.0	1.4361	60		refined American wax	
	"	1.4359	"	"	"	
	"	1.4353	"	"	"	
	"	1.4359	"	"	"	
	"	1.4355	"	"	"	
	"	1.4352	"	"	"	
	"	1.4346	"	"	"	
	"	1.4343	"	"	"	
	"	1.4342	"	"	"	
	"	1.4348	"	"	"	
[13, 1924]	51.7	1.4481*	25		parowax	
	"	50.0	1.4485*	"	refined wax	
	"	50.0	1.4487*	"	"	
	"	51.7	1.4479*	"	"	
	"	51.7	1.4481*	"	"	
	"	54.4	1.4475*	"	"	
	"	54.4	1.4476*	"	"	
	"	48.3	1.4570*	"	scale wax	
	"	48.3	1.4568*	"	"	
	"	42.2	1.4240	80		"
[6, 1931]	47.3	1.4346	60		"	
	"	51.2	1.4361	"	"	
	"	45.3	1.4272	80	19.0	sweated fractions of Polish wax of 51-2° C m p
	"	48.0	1.4275	"	31.0	"
	"	49.8	1.4276	"	17.7	"
	"	51.6	1.4282	"	11.3	"
	"	54.9	1.4291	"	10.3	"
	"	59.0	1.4299	"	8.8	"
	"	47.7	1.4267	"	15.2	sweated fractions of Asiatic wax of 50° C m p
	"	48.3	1.4270	"	9.5	"
[8, 1930]	49.0	1.4274	"	8.5	"	
	"	49.6	1.4276	"	7.1	"
	"	50.6	1.4280	"	9.5	"
	"	51.2	1.4282	"	8.5	"
	"	52.0	1.4284	"	10.0	"
	"	52.8	1.4286	"	9.5	"
	"	54.0	1.4287	"	10.5	"
	"	54.6	1.4289	"	4.3	"
	"	55.8	1.4290	"	3.3	"
	"	58.0	1.4291	"	4.3	"

* Determined at 25° C in oil solution

REFERENCES

- CARPENTER, J. A. *JPT* 12, 303 (1926)
- DROG, S. H., and BUCHLER, C. C. *Ind Eng Chem* 19, 125 (1927)
- EYKMAN, J. F. *Recueil des travaux chimiques des Pays-Bas*, 15, 56 (1896/8)
- FERRI, S. W., COWLES, H. C., JR., and HENDERSON, L. M. *Ind Eng Chem* 21, 1092 (1929)
- , *Ind Eng Chem* 23, 682 (1931)
- FERUND, M. *Rev. Z.* 27, 409 (1931)
- GURWITZCH, L., and MOORE, H. *The Scientific Principles of Petroleum Technology*, 457 (Chapman & Hall, London, 1926).
- KATZ, E. *JPT* 16, 870 (1930)
- MORRIS, F. J., and ADKINS, L. R. *Ind Eng Chem*, 19, 301 (1927)
- PAGE, J. M., Jr. *Ind Eng Chem* 28, 856 (1936)
- PROTOWSKI, W. A., and WINKLER, J. *Erdöl u. Teer*, 6, 447, 463 (1930)
- SEIDER, G. N., and GROSS, W. J., Jr. Data published by courtesy of Atlantic Refining Co.
- WILSON, R. E., and WILKINS, R. E. *Ind Eng Chem* 16, 9 (1924)

REFRACTIVE INDEX OF PARAFFIN WAX

By C. R. SCOTT HARLEY

Published by permission of The *Burmah Oil Company, Ltd*

REFRACTIVE index, being a value which is determinable rapidly and with exactitude and by means of a very small quantity of material, has potential practical applications which have not yet been adequately explored. Some indications of its significance and utility are presented in this article.

While refractive index cannot afford a measure of the very small proportion of oil contained in a refined wax, by means of this value the proportion of oil and wax in a mixture such as 'Pressable Wax Distillate' can be determined with sufficient accuracy for all practical purposes. The method can be used to great advantage when applied, for example, to an investigation of the process of filter-pressing wax distillates [3, 1931, 8, 1930]. For such a purpose it is necessary to carry out a filtering operation under carefully controlled thermal conditions at a temperature corresponding to the refinery practice and to pursue the operation to give the densest possible cake. Providing there has been no leakage in the system, the filtrate should possess a setting-point several degrees lower than the temperature of filtration. This oil can be regarded as containing nil wax at the filtration temperature and can be used therefore as one of the components for the preparation of a refractive index/oil content curve. The other component should comprise the range of constituents which are precipitated at the filtration temperature and not any which would be separated at a lower temperature. To obtain such a material it is necessary to remove the remainder of the associated oil from the cake without precipitation of any of the wax which would normally remain dissolved in the oil at the temperature of separation. A convenient procedure has been determined as follows. It is necessary first to find the smallest proportion of the chosen solvent, such as methyl ethyl ketone, which will completely dissolve the whole of the scale (pressed cake) at an elevated temperature and which at the low temperature of filtration will constitute a mixture sufficiently fluid to pour. In a particular instance a mixture of 3 parts of solvent to 1 part of scale was found to be satisfactory. In order to find the temperature at which this mixture should be filtered, a sample of the filtrate is mixed with the solvent in the same proportion and its setting-point determined. This is regarded as a suitable temperature for filtering the scale solvent mixture. The filtration should be carried out twice or preferably three times in order to remove the last traces of oil. In a specific instance the filtrates were collected, the solvent removed by distillation, and the residual oil was found to possess a setting-point within 2° F. of the original filtrate. For removal of the last traces of solvent from the precipitated wax it was found necessary to apply vacuum during distillation with a stream of carbon dioxide. By recombining the oil-free wax and wax-free oil in known proportions and determining the refractive indices of these mixtures, it is possible to construct a curve from which the oil content of an unknown mixture of these components can be determined. It is, of course, essential to construct such a curve for each stage of filter-pressing. By such means it is possible to determine quite rapidly not only

the variations of oil content of the scale cakes, but also the overall efficiency of any particular set of conditions relating to filter-pressing. Furthermore, an accurate knowledge of the concentration of wax in the distillate throughout the temperature range concerned can be derived. A typical set of values is included in the following table.

TABLE I
Relationship between Refractive Index and Oil Content for three stages of pressing Wax Distillate

Per cent Oil Wax		First scale, representing wax precipitated between 108 and 78° F.	Second scale, representing wax precipitated between 78 and 56° F.	Third scale, representing wax precipitated between 56 and 39° F.
0	100	1.4378	1.4345	1.4329
10	90	1.4425	1.4403	1.4395
20	80	1.4473	1.4451	1.4462
30	70	1.4525	1.4520	1.4530
40	60	1.4578	1.4579	1.4591
50	50	1.4611	1.4641	1.4661
60	40	1.4684	1.4708	1.4733
70	30	1.4739	1.4775	1.4806
80	20	1.4796	1.4843	1.4880
90	10	1.4856	1.4912	1.4956
100	0	1.4916	1.4986	1.5042
Temperature coefficient	0.0004 per 1° C	0.0004 per 1° C	0.0004 per 1° C	0.0004 per 1° C
Refractive index coeff of wax	0.00054 per 1% wax	0.00064 per 1% wax	0.0007 per 1% wax	0.0007 per 1% wax
Setting-point of oil-free wax	138.8° F.	120.3° F.	107.7° F.	

The fact that the refractive index of a wax (excluding cereasins) is inappreciably changed by very small proportions of oil, well-refined commercial waxes usually containing insufficient oil to affect these values, permits the use of this physical constant and its relationship to melting-point or setting-point in comparing waxes derived from different sources and separated by different methods.

It has become possible to correlate some of the results of various workers in this field of petroleum science on the basis of refractive index and setting-point, and to secure a more comprehensive view of numerous investigations which have been carried out on synthetic, technical, and commercial waxes. At the same time, it would be more advantageous if these two constants were recorded more frequently when possible. Determination of molecular refraction or even specific refraction would probably be still better, but owing to the time required for the former and the difficulties involved in the latter determination, very little information is available.

Buchler and Graves [1, 1927] examined a series of paraffin waxes, petrolatum, slop wax, and rod wax from Salt Creek, Wyoming, and came to the conclusion that these consisted mainly of normal paraffin hydrocarbons. If the values of refractive index are plotted against melting-point, it will be seen that the curves so obtained are almost parallel and occasionally coincident with the curve,

illustrated in the graph, representing the homologous series C_nH_{2n+2} .

Restle and Blade [9, 1932] also examined rod wax from Salt Creek, amongst several others, and obtained a series of fractions having distinctly different physical constants such as $m p$ / refr index, which they attribute to the presence of iso-paraffins or branch-chain series.

Sachanen and others [10, 1931] record the refractive index/melting-point relationship of paraffins from Grozny crude, which exhibits an approximate parallelism with the curve for normal paraffins, although appreciably removed therefrom since the separated waxes did not represent single hydrocarbons. The positions of the ceresin fractions from Surakhany crude, however, show a very wide divergence from the values of normal paraffins and suggest a preponderance of other types of compounds.

In order to compare commercial waxes from different sources an attempt has been made to produce a series of curves based upon the relationship between the refractive index and the setting-point. The full-page graph on opposite page contains only a selection of curves derived from Tables II to V included below, in order to avoid confusion

only four values between C_{20} and C_{28} , the values published by Ivanovsky [4, 1935], which are derived from many sources, have been chosen. All the values have been converted to a standard temperature of 60° C for comparison with those of numerous commercial grades which have been determined at that temperature. The relationship is expressed by the formula $n_D^{60} = 0.00047 + 1.4128$, where $T =$ the melting-point of the wax.

It will be observed that the curves for the commercial grades are by no means parallel to the 'normal' curve. Commencing with setting-points around 42° C, they tend to approach the 'normal' curve in a zone of 60–65° C. It is suggested that these relative positions indicate in a very general way that the lower setting-point grades represent a wider cut than those which approach the 'normal'. The fact that they tend to converge towards one zone is probably explained by the process of manufacture in which a suitable distillate is fractionated for pressing.

Two other types of curves are included which exhibit the essential difference between products fractionated from pressed scale by sweating and those fractionated by distillation. The whole of the wax from a pressable wax

TABLE II

Values published by L. Ivanovsky [4, 1935]

Normal paraffins			Iso-paraffins			Polymethylene series			Naphthene series		
No C atoms	$m p$, °C	n_D^{60}	No C atoms	$m p$, °C	n_D^{60}	No C atoms	$m p$, °C	n_D^{60}	No C atoms	$m p$, °C	n_D^{60}
C_{18}	28	1.4236	C_{18}	18.3	1.4257	C_{18}	61	1.4600	C_{21}	25	1.4452
C_{18}	32	1.4259	C_{18}	—3	1.4281	C_{18}	57	1.4607			
C_{20}	36.7	1.4275	C_{20}	6.5	1.4303	C_{17}	65	1.4585			
C_{21}	40.5	1.4287	C_{20}	—80	1.4380	C_{18}	72	(1.4584)			
C_{21}	44.4	1.4305	C_{20}	32	1.4441	C_{21}	46	1.4559			
			C_{20}	34							
C_{21}	47.7	1.4319	C_{20}	18	1.4444	C_{20}	42	1.4562			
	(48)										
C_{24}	51.1	1.4323	C_{24}	23	1.4448	C_{21}	48	1.4567			
C_{24}	53.8	1.4341	C_{24}	49	1.4452	C_{20}	56	1.4601			
	(54)		C_{21}	50							
C_{28}	56.6	1.4355	C_{27}	39	1.4464	C_{20}	44	1.4884			
			C_{21}	40							
C_{27}	59.5	1.4366	C_{21}	65	1.4492	C_{21}	52	1.4573			
			C_{21}	64							
			C_{21}	65							
C_{28}	62	1.4375									
C_{28}	(63.4)	1.4384									
	64.1										
C_{31}	68	1.4400									
	(69)										
C_{31}	70	1.4408									
C_{31}	74.7	1.4434									
C_{31}	(75.8)	1.4432									
	76										
C_{37}	77.4	1.4444									
C_{31}	79.2	1.4442									
	(79.4)										

Note: Numerous other values have been recorded by Ivanovsky, but only the values which give both the $m p$ and refractive index have been extracted.

TABLE III

Values from International Critical Tables (1926)

	$m p$, °C	n_D^{60}
$n-C_{20}H_{42}$	38.0	1.4272
$n-C_{21}H_{44}$	40.4	1.4285
$n-C_{27}H_{56}$	47.7	1.4319
$n-C_{28}H_{58}$	75.0	1.4408

A curve representing normal paraffin hydrocarbons which have been synthesized by numerous investigators has been included. As the International Critical Tables (1926) provide

distillate was de-oiled by suitable solvents and then fractionated into the usual grades by sweating. The representative curve is displaced farther away from the normal, as would be expected by reason of the fractions representing wide cuts, and the slope is appreciably steeper than those representing the usual commercial grades. Distilled waxes are represented by the series 80A to 80R in which the first fraction is coincident with the 'normal' curve, and most of the remaining fractions lie in a region only slightly below this line. The residue possesses a distinctly higher refractive index and exhibits quite different properties. It is considered likely that such products contain increasing



FIG. 1 Approx ($\times 5$)



FIG. 4 $nC_{10}H_{16}$ ($\times 40$)

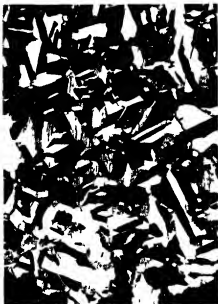

FIG. 2 ($\times 40$)



FIG. 3 ($\times 40$)

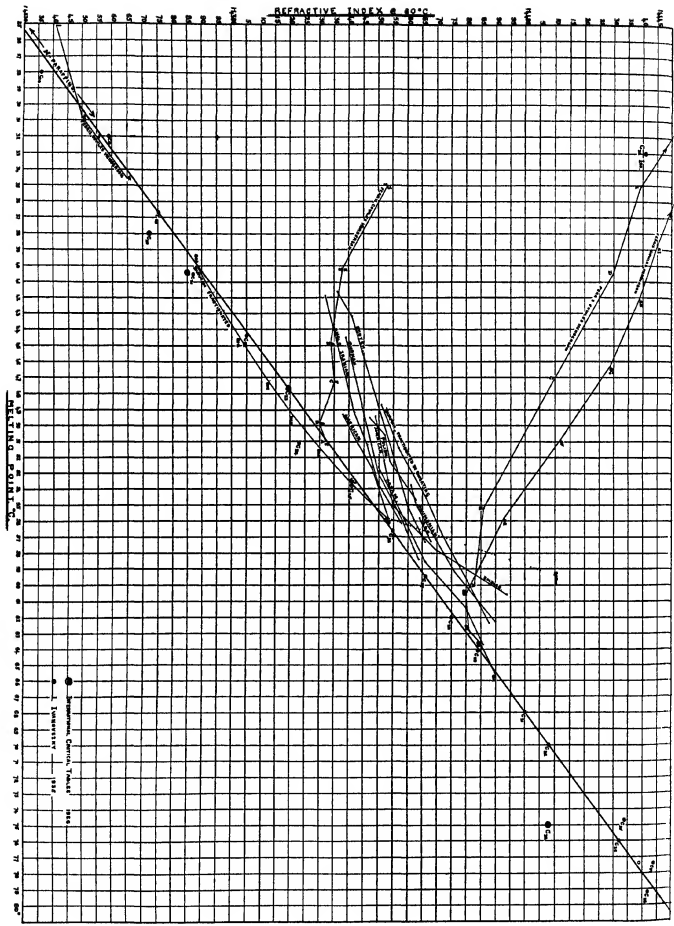

FIG. 5 $nC_{14}H_{26}$ ($\times 40$)



FIG. 6 $nC_{20}H_{42}$ ($\times 40$)

REFRACTIVE INDEX @ 40°C



proportions of iso-paraffins or cyclic or naphthenic hydrocarbons, and it is evident that separation by sweating is the least effective of all methods. Whilst these fractions are much narrower cuts and the general curve approaches the 'normal' more closely, it is not contended that such mixtures are necessarily composed of the normal paraffins only, although it is probable that these compounds preponderate

TABLE IV

Ferris, Cowles, and Henderson [2, 1931]			Page [7, 1936]		
Identifi- cation symbol	m p. ° C	n _D ²⁰	Identifi- cation symbol	m p. ° C	n _D ²⁰
1	25.1	1.4241	1	49.4	1.4349
2	30.8	1.4250	2	52.2	1.4352
3	32.1	1.4255	3	55.0	1.4355
4	34.6	1.4265	4	57.8	1.4370
5A	51.0	1.4332	5	60.6	1.4394
5B	49.9	1.4330			
5C	47.3	1.4335			
5D	44.9	1.4334			
5E	40.2	1.4338			
5F	35.1	1.4353			
6A	65.6	1.4390			
6B	63.6	1.4385			
6C	62.8	1.4381			
6D	60.6	1.4380			
6E	55.8	1.4393			
6F	50.9	1.4412			
6G	46.3	1.4429			
6H	42.1	1.4439			
6J	38.8	1.4445			
6I	34.0	1.4455			
A	59.9	1.4383			
B	55.2	1.4386			
C	47.1	1.4410			
D	40.5	1.4430			
E	35.2	1.4439			
F	29.4	1.4460			

The remaining curves are derived from the work of Ferris, Cowles, and Henderson [2, 1931], who separated a series of waxes by fractional crystallization. These curves are remarkable on account of the reverse relationship of decreasing refractive index with increase of melting-point. Quite apart from other physical considerations, this fact appears to indicate the existence of a different class of hydrocarbons, in substantial proportions, in materials which were hitherto regarded as mainly normal paraffins. It will be observed that these three curves are approximately parallel to each other, although the series 5A to 5F have very much lower indices for similar melting-points. A similar relationship has been observed also by Müller, Jacob, and Pilat [6, 1935], who separated wax from asphalt without any distillation. These values have not been plotted, as they do not fall within the range of coordinates used in the appended graph, but the authors conclude that these hydrocarbons possess a cyclic constitution.

From the evidence presented by these curves and tables it appears that the types of compounds which are separated by various means differ according to the particular method employed. It is impossible to illustrate the relative positions of numerous iso-paraffins and cyclic hydrocarbons which have been synthesized, as their refractive indices are very much higher than those already considered, but the values are shown in the tables. In this connexion it is impossible for saturated aliphatic hydrocarbons to possess refractive indices of such high values, which are found only with unsaturated cyclic hydrocarbons having a conjugate linkage or in compounds other than hydrocarbons.

Whilst the interpretation to be placed upon the relative position of a single specimen should be reached with caution, it is considered that a series of values is likely to indicate the predominating type of compounds present. It has been observed with the usual commercial grades that the narrower cut waxes generally approach the curve for

TABLE V

Values obtained from Commercial Paraffin Waxes and Experimental Products

Grade	m p. ° C	n _D ²⁰	Grade	m p. ° C	n _D ²⁰		
<i>Burma</i>	Match wax	44.5	1.4339	<i>Polish</i>	49.5	1.4347	
	125/30	53.0	1.4350		50/2	50.6	1.4352
	130/5	55.9	1.4358		52/4	52.3	1.4354
	135/40	58.4	1.4364		54/6	54.7	1.4363
<i>Assam</i>	125/30	52.6	1.4350	<i>American</i>	118/20	49.3	1.4338
	115/40	58.5	1.4366		122/5	50.8	1.4342
	140/5	61.3	1.4380		125/7	52.7	1.4348
	145/50	63.7	1.4386		130/5	56.0	1.4354
<i>Iranian</i>	106/8	41.9	1.4232	<i>American</i>	130/5	55.8	1.4364
	118/20	49.2	1.4342		135/40	57.3	1.4368
	124	51.2	1.4346				
	125/30	53.7	1.4350				
	130/5	56.2	1.4358				
<i>Scotch</i>	106/8	41.6	1.4336	<i>Burma Oil-free wax distillate</i>	115/20	48.7	1.4351
	110,15	43.2	1.4341		120/5	51.4	1.4357
	122/5	51.8	1.4355		125/30	54.4	1.4366
	130/5	55.1	1.4360		130/5	56.8	1.4372
	135/40	57.3	1.4366		135/40	59.5	1.4380
					140/5	62.3	1.4388
					Over 145	65.1	1.4396
<i>Roumanian</i>	122/5	53.7	1.4361	<i>Burma Fractd by distillation</i>	80A	39.9	1.4288
	125/30	55.0	1.4363		80B	44.6	1.4303
	130/5	55.7	1.4365		80C	47.2	1.4313
	135/40	59.1	1.4376		80D	49.4	1.4321
	140/5	62.2	1.4390		80E	51.4	1.4330
			80F		53.7	1.4341	
			80G		55.8	1.4353	
			80H		59.4	1.4410	
<i>Retzuan</i>	53.4	1.4330	<i>Iraq</i>	51.6	1.4347		
	54.7	1.4354		53.2	1.4352		
	55.2	1.4358		56.1	1.4362		
	55.8	1.4360		57.2	1.4363		
56.8	1.4363						
<i>Borneo</i>	53.4	1.4349	<i>South Manchurian</i>	53.3	1.4355		
	54.3	1.4351		54.6	1.4359		
	55.7	1.4357		57.5	1.4365		
	57.1	1.4367					
	63.0	1.4386					

Note: The terms 'setting-point' and 'melting-point' are used somewhat loosely, and in cases in which the method of determination is not known the former term has generally been employed.

'normal' paraffins. By fractional distillation of any such wax the values obtained from the distillates usually develop an approximate straight line which is parallel to the normal curve and becomes closer as the cut becomes narrower. If it is assumed that such a relationship indicates a preponderating quantity of normal paraffins being present, it



FIG. 7 $n\text{-C}_{20}\text{H}_{42}$ (40)

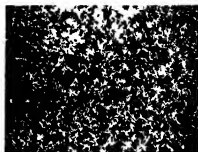

FIG. 8 $n\text{-C}_{11}\text{H}_{24}$ (40)



FIG. 9 $n\text{-C}_2\text{H}_4$ (40)



FIG. 10 $n\text{-C}_{11}\text{H}_{24}$ (40)

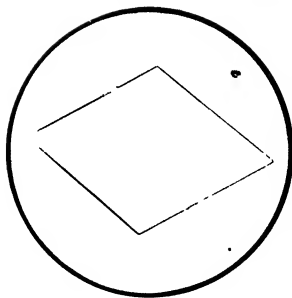

FIG. 11 (400)



FIG. 12 (170)

is difficult to understand why the selection of waxes used by Page [7, 1936] should be regarded as belonging to the series C_nH_{2n+2} .

Refractive Indices of Paraffin Wax in the Solid State.

A certain amount of work has been carried out on pure synthesized hydrocarbons and technical products in the solid state which reveals distinct possibilities of providing useful information when the correct interpretation has been established. In a recent paper by Page [7, 1936] a method has been described in which the liquid film of wax is allowed to solidify between the prisms of an Abbé refractometer, giving two dark fields which are claimed to represent the ordinary and extraordinary refractive indices. If paraffin wax is uniaxial, one value will be n_{ω} , but the other value cannot be n_x unless the optic axis of the crystal is normal to the rays which enter the upper prism at grazing incidence. Furthermore, some waxes possess at least two orientations, and three dividing lines can be seen corresponding to refractive indices (1) n_{ω} , (2) between n_{ω} and n_x depending upon orientation, (3) n_x .

Larsen and Berman [5, 1934] classify paraffin wax in the uniaxial group with the following values n_x 1.550, n_{ω} 1.502, Birefringence 0.048. It will be observed that in this case $n_x > n_{\omega}$, whereas Page's figures show $n_{\omega} > n_x$.

Restle and Blade [9, 1932] state that wax crystals are biaxial with 2E approximately 45°. This is confirmed by the photograph Fig. 1, which shows the biaxial interference figure of a paraffin crystal with 2E 43°.

If it be assumed that the crystals arrange themselves in all directions, then the two values should correspond to n_x and n_y . On the other hand, if there is any preferential orientation, which is distinctly possible, or a system possessing two types of crystalline structure, then it is probable that other dividing lines may be seen which may have values between the two extremes.

Two waxes which are also recorded on the graph have the properties given in (Table VI).

It is evident that further investigation into the validity of this method is required before any conclusions can be accepted.

These two waxes are rather remarkable and are best illustrated by photomicrographs. It will be observed that No. 80A (Fig. 2—Mag $\times 40$), which exhibits no transition point, possesses only one type of crystalline structure throughout. Numerous cleavage edges can be seen which, however, gradually disappear on standing for a long time. The boundary edges between crystal aggregates show very

small crystals which are gradually absorbed by the larger ones.

TABLE VI

	80A	80B	
Setting-point, °C	39.9	44.6	
Transition-point, °C	Absent	30.0	
n_D^{20}	1.4288	1.4303	
n_D^{25}	1.4385*	} n_D^{25} *	
	1.4705		1.4775
	1.5190		1.5285
n_D^{30} *	1.4843	} n_D^{30} *	
	1.5334		1.5465

* It is probable that this value represents some of the wax in the liquid phase.

No. 80B (Fig. 3—Mag $\times 40$) exhibits a transition-point at 14.6° C below the setting-point and shows two distinct types of crystals. The long lath-shaped crystals exhibit straight extinction, whereas the small plates, which constitute the ground mass, have oblique extinction and other contrasting properties. It was thought that the presence of two distinct types of crystals might indicate the existence of two series of hydrocarbons until a similar phenomenon was discovered in the structure of some of the pure normal paraffins, particularly in $C_{24}H_{50}$. Photomicrographs of the following seven normal aliphatic hydrocarbons illustrate the variation which exists in the general crystalline structure, and show the remarkable contrast in the two odd members of the series compared with the others. All are reproduced at Mag $\times 40$.

$n-C_{14}H_{30}$, Fig. 4; $n-C_{16}H_{34}$, Fig. 5; $n-C_{18}H_{38}$, Fig. 6 (by courtesy of Dr. Alex. Mueller, as used for X-ray work); $n-C_{20}H_{42}$, Fig. 7; $n-C_{22}H_{46}$, Fig. 8; $n-C_{24}H_{50}$, Fig. 9 (by courtesy of Prof. G. I. Finch, as used for electron diffraction work); $n-C_{26}H_{54}$, Fig. 10.

The last two photomicrographs depict other interesting features concerning the crystallization of wax. Fig. 11 ($\times 400$) represents two rhombic plates of paraffin, and illustrates the shape of the unit cell when it is free to form without disturbance. The crystals are practically isotropic and are photographed by the diffraction of the edges. The thickness of the smaller crystal (the upper) is of the order of 0.1μ . The angles are 67.9° and 112.1° approximately. Fig. 12 ($\times 170$) is a good example of a crystal aggregate showing the lamination of very thin plates parallel to the basal plane. It is interesting to observe the formation of these plates out of the semi-morphous wax adjoining and the development of two sets of rhombic plates from the acute angles mentioned above.

REFERENCES

1. BUCHLER, C. C., and GRAVER, G. D. *Ind. Eng. Chem.* 19, 718 (1927).
2. FERRIS, S. W., COWLES, H. C., JR., and HENDERSON, L. M. *Ind. Eng. Chem.* 23, 481-8 (1931).
3. FREUND, M. *Petr. Z.* 27, 409-10 (1931).
4. IVANOVSKY, LEO. *Ozokerit und verwandte Stoffe*, II Band, 2 Teil (1935).
5. LARSEN, ESPEER S., and BERMAN, H. *U.S. Geol. Survey Bull.* 848 (1934).
6. MULLER, JACOB, and PILAT, S. *J. I.P.T.* 21, 887-94 (1935).
7. PAGE, J. M., JR. *Ind. Eng. Chem.* 28, 856-9 (1936).
8. POTROWSKI, W. V., and WINKLER, J. *J. I.P.T.* 16, 448A (1930).
9. RESTLE, C. E., JR., and BLADE, O. C. *U.S. Bur. Mines Bull.* 348 (1932).
10. SACHANEN, A. N., ZHERDVA, L. G., and VASILYEV, A. N. *Nat. Petr. News*, 29 April 1931.

SPECTROGRAPHIC AND X-RAY APPLICATION

THE APPLICATION OF THE INFRA-RED ABSORPTION SPECTRA TO THE STUDY OF PETROLEUM OILS AND SPIRITS

By J. LECOMTE

Introduction

It is well known that the infra-red absorption spectra are of great use in the analysis of organic compounds. In this article it is proposed to give a résumé of the results obtained in France utilizing this method, with regard to petroleum oils and spirits. The portion of the infra-red spectra which is best used for these determinations is that between the visible end and a wave-length of 20μ , that is, wave-lengths between 6 and 20μ .

The following are the principal reasons for using this method

1 All the substances possess numerous absorption bands in the region given. The hypothesis of Abney and Festing (1881) should be recalled here, that different groupings are characterized by infra-red absorption bands, which are peculiar to certain organic groups present in the molecule.

2 Using wave-lengths between 6 and 20μ it is sufficient if only 0.01 to 0.1 mm thickness of material be present in the case of liquids, and a thickness of several microns with solids, in order to obtain detailed absorption spectra.

An analysis can thus be carried out with extremely small quantities of material present, and therefore this method is applicable to very rare substances, to analyse different fractions from a distillation or to the different products obtained in the course of a synthesis.

3. The infra-red radiation does not have any action on petroleum spirits or their constituents.

I. Experimental Technique

(a) **Spectrometer.** Two spectrometers have been used, the dispersive system being composed of a single 60° prism (or two 30° prisms), that is, the simplest conditions have been applied. A flint prism gave a wave-length of $8-14 \mu$, in a prism made of potassium bromide $13-20 \mu$, and of rock salt $8-14 \mu$. It should be noted that these prisms gave the best experimental conditions from the absorption point of view. The first spectrometer is the Wadsworth type (Fig 1)

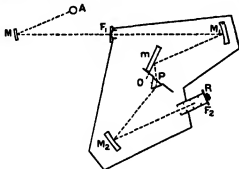

FIG 1.

The radiation from source A is concentrated on the slit F_1 by the concave mirror M_1 , it is then rendered parallel by the concave mirror M_2 , and is finally reflected by the

plane mirror m , from which it passes through the prism P and is concentrated by mirror M_2 on to the slit F_2 of the receiver R . In this arrangement every part is fixed with the exception of the prism P and the plane mirror m , which are placed on a rotating platform with an axis O . In this way, if the prism P be set for minimum deviation for a visible radiation, only those radiations strike the receiver during the rotation of the prism which have traversed the prism at its angle of minimum deviation. It is advantageous for the axis O to be the intersection of the plane of the mirror m and the plane of the bisector of the angle of refraction of the prism.

In the second spectrometer Fig 2 there are two 30°

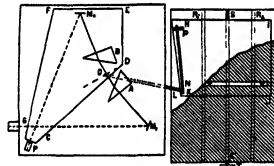

FIG 2

prisms, one of which, A , is fixed and the other, B , is mounted on a movable table $CDEFG$, revolving on its vertical axis O . The table carries the concave mirror M_2 and the thermo-electric couple P . Radiation entering via the slit at G is rendered parallel by the concave mirror M_1 , it then traverses the two prisms A and B and is concentrated by the mirror M_2 on the couple P .

(b) **Measurement of Infra-red Absorption Spectra.** A cell containing the liquid to be examined is placed in front of the slit, i.e. at F_1 (Fig 1). The cell consists of two thin glass plates separated by small paper packing pieces of 0.01-0.1 mm in thickness. In place of glass plates, flint prism plates are used for wave-lengths between the visible spectrum and 8μ , rock-salt plates up to 15μ , and potassium bromide plates up to and above 20μ . The spectrometer is illuminated with a Nernst lamp, with the image formed as in Fig 1. In order to measure the small temperature differences at different points in the spectrum a thermo-electric couple with a sensitive galvanometer was used. The galvanometer deflection is noted for each point on the spectrum, first when the substance under examination is placed in the path of the rays, and secondly with the light source alone. The two figures thus obtained give the 'Gross Transmission' for each wave-length. If it be desired to know not only the position of the absorption bands but their exact intensity, then corrections must be made for reflection and diffusion of the light rays.

(c) **Automatic Registering Apparatus.** Instead of making measurements by means of a visual arrangement, the

infra-red spectra can be registered automatically, which method of measurement is easier, more rapid, and precise. Two methods are given, by one of which spectra of wavelengths from 6 to 15 μ can be obtained within 20 min

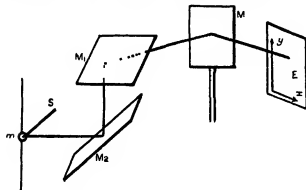

FIG 3

In the first case (Fig 3) a plane mirror M is fixed to and rotates with the platform of the spectrometer of Fig 1. The mirror M receives the image of the spot by light from the galvanometer and light source S , and this light is reflected on to sensitized photographic film E , fixed in a vertical position. The abscissae on the film represent the wave-lengths, and the ordinates representing the radiation intensities are obtained by transposing the horizontal movements of the light spot from the galvanometer's rotating mirror by interposing between this mirror and the mirror M a system of two fixed plane mirrors M_1 and M_2 , placed one above the other with the lower one inclined at an angle of about 45° to the horizontal mirror. This arrangement is satisfactory when the curve traced on E corresponds to an axis system XY with rectangular coordinates. The two mirrors inclined at the 45° angle can be replaced by two prisms.

With the second arrangement the galvanometer illuminated by an auxiliary light inscribes its light spot on the slit UV of the lid (Fig 2). The sensitized film is placed on the holder HJK , this latter has beneath it a threaded screw SS^1 , on the end of which is a pulley T connecting with an electric motor. This arrangement allows variable angles to be obtained with the cam NP and thus a rapid rotation of the axis O .

II. Experimental Results

1. Application to the Analysis of the Pure Components of Petroleum Oils and Spirits.

The infra-red absorption spectra method is applicable to all hydrocarbons without any exceptions from the saturated and unsaturated hydrocarbons to the anthracene group and hydrocarbon groups possessing large numbers of carbon atoms as netene and fluorene.

(a) **Determination of the Degree of Impurity of a Hydrocarbon.** Fig. 4 gives the curves of the purest hexane prepared (curve 1) and other hexanes containing traces of impurity (curve 2). In Fig 5 the curve of *o*-xylene is given, but actually this product contains traces of *m*- and *p*-xylenes, which are discerned from the absorption bands marked *m* and *p*. By this method 1% of impurity can be detected.

(b) **Distinction between Isomeric Hydrocarbons.** Aliphatic saturated straight-chain hydrocarbons are easily distinguished from those possessing branched chains. For example, Fig. 6 shows *n*-decane and di-isomyl. The

branched-chain isomer has not even the same infra-red absorption spectra, Fig 7 gives methyl-diethyl-methane

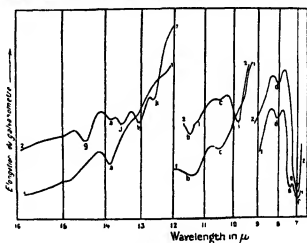

FIG 4

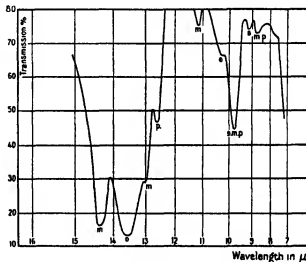

FIG 5

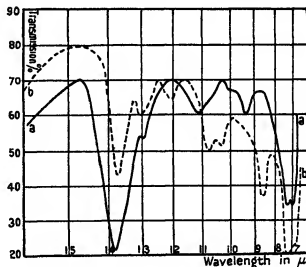

FIG 6

and trimethyl-ethyl-methane. For ethylene type hydrocarbons the infra-red absorption spectra show the

isomerism occurring at the double and the branching of the chain, e.g. Fig 8—dimethyl-1,2,5-hexene-2 and dimethyl-2,4-hexene-4. The method is applicable in the case of

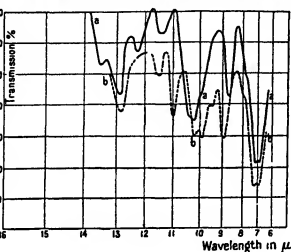

FIG 7

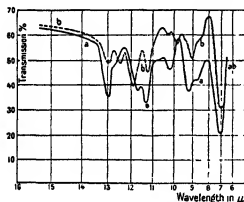

FIG 8

benzenoid hydrocarbons to distinguish between position isomers, e.g. *ortho*-, *meta*-, and *para*-xylenes (Figs 9 and 14), or where the isomers differ by the form of the substituted chain, e.g. propyl and isopropyl benzene. The absorption

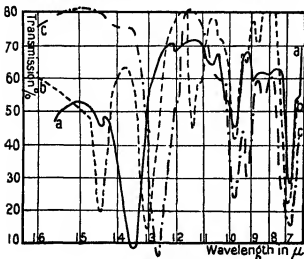

FIG 9

spectra of position isomers are different from these hydrocarbons substituted in the lateral chain, e.g. xylenes and ethyl benzene. With cyclohexane type hydrocarbons it is possible to distinguish stereo-isomers, e.g. *cis*- and *trans*-*ortho*-dimethyl cyclohexanes (Fig 10). Application of this method to much heavier hydrocarbons has led to equally

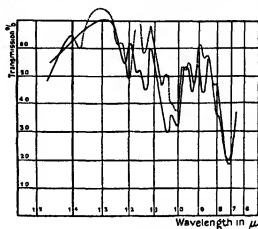

FIG 10

good results, e.g. dimethyl-naphthalenes 1,6 and 2,6 (Fig 11), or dibutyl anthracene 9-10 and di-isobutyl-9-10 anthracene (Fig 12). With the exception of aliphatic

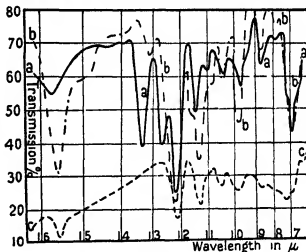

FIG 11

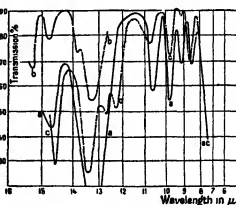

FIG 12

hydrocarbons, it is often advantageous in order to distinguish between the isomers to carry out determinations at wave-lengths from 14 to 20 μ .

(c) **Distinction between Homologues.** It is clearly seen from Fig 13 that the homologues of the saturated aliphatic

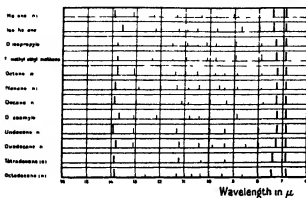

FIG 13

hydrocarbons give very different infra-red absorption spectra, even more noticeably than the benzene hydrocarbons substituted in the lateral chain (toluene-ethylbenzene, propyl benzene, &c)

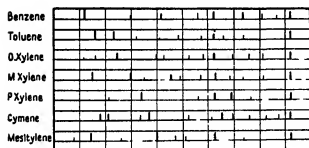

FIG 14

Large differences are also found between the infra-red absorption spectra of substances not strictly homologues, such as the products of hydrogenation of the naphthalene and anthracene nucleus, e.g. tetrahydro-, octahydro-, decahydro-, perhydro-anthracene (Fig 16). This observation is interesting in the case of oils. In order to distinguish between successive homologues it is often useful to determine not only the position of the absorption bands, but also their intensity and absolute value, taking as coordinate not only percentage change, but the molecular absorption coefficient.

(d) **Identification of Hydrocarbons.**

The large number of absorption bands of hydrocarbons existing between the wave-lengths of 6 and 20 μ show that pure hydrocarbons can be identified by this method, but in order to be certain, a large number of infra-red absorption spectra must

be known. Nevertheless, the analogy existing between the spectra of hydrocarbons derived from the same group permits the series to be determined to which the pure hydrocarbons belong. To this end the spectral zones of 6 to 7 μ and from 12 to 14 μ are particularly useful. For

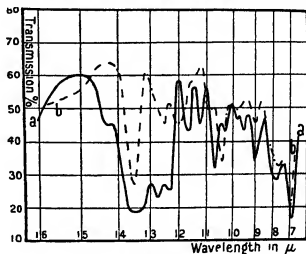

FIG 15

classification of isomers the 7 to 12 μ and 14 to 20 μ zones are the most useful (Fig 15).

Application to Hydrocarbon Mixtures and to Petrols.

As an example fractions obtained by distillation of tri-ethyl benzene have been taken. Five fractions were obtained under ideal experimental conditions between 214 and 219° C, that is, at the boiling-points given in the literature for the two isomers 1,2,4 and 1,3,5. (The third possible isomer 1,2,3 is probably not stable.) In Fig 17 the curve corresponding to the first fraction indicates that diethyl benzene is present. The curves relative to the other fractions, which are not all reproduced, indicate that no diethyl benzene is present (2nd fraction). Fractions 3 and 4 are identical and probably correspond to the 1,2,4 isomer in the pure state. With fraction 5 a trace of tetra-ethyl benzene (10.3 μ wave-length) and another constituent (9.95 μ wave-length) were found to exist.

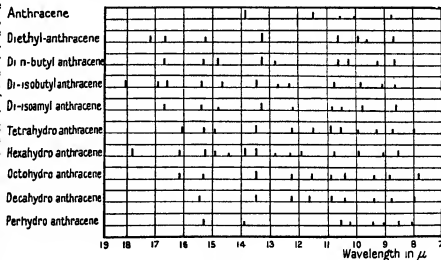

FIG 16

By a systematic study of binary mixtures of hydrocarbons (benzene-toluene, benzene-cyclohexane, &c) the quantitative proportion of each hydrocarbon in the mixture can be obtained. The limit of accuracy is 1%, but the error in the quantitative determination is somewhat greater.

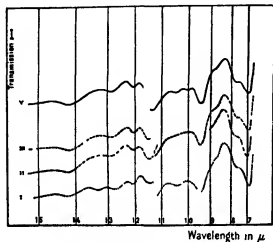

FIG 17

In the case of petrols the infra-red absorption spectra can be used to control their composition. In this case a direct comparison is made. The problem of determining the composition of a petrol, however, is extremely complicated due to the number of constituents that can be present, and it is not intended to give such an analysis in this article. In Figs 18, 19, and 20 are given examples of infra-red absorption spectra of fractions obtained from the distillation of a petrol. Different curves relating to the same petrol are obtained, with a rise in temperature. Certain absorption

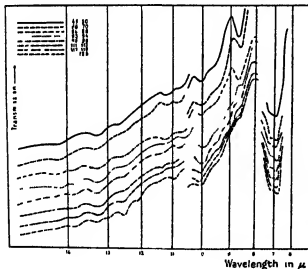

FIG 18

bands disappear and new ones replace them. It is impossible to know in all cases to which hydrocarbons the different bands correspond, but the method shows rapidly the presence or absence of a known constituent. On comparing the curves in Figs 18, 19, and 20 differences are observed showing that the infra-red absorption spectra of petrols produced from different sources vary.

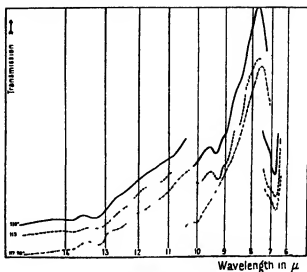

FIG 19

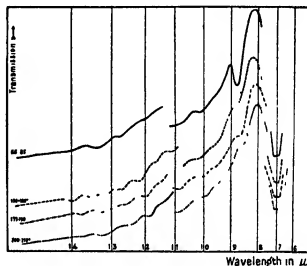

FIG 20

III. Application to Oils

It is a well-known fact that the analysis of oils by ordinary chemical means is almost an insoluble problem, numerous physical processes are inconvenient and change the state of the oil molecules or even cause chemical changes to occur. Infra-red absorption spectra methods, however, do not present these difficulties and are particularly valuable in the analysis of oils.

In the first instance various oil samples have been obtained by distillation in the cathode vacuum of two oils (Figs 21 and 22). For example, in the case of the first oil the samples 1, 3, 4 were taken between the following ranges: 100-9° C, 121-1° C, 121-5° C. The results of the infra-red absorption analysis are given in the following:

(1) For each oil the corresponding curves for each fraction are analogous, yet they also show differences. This signifies that the different fractions are composed of analogous hydrocarbons, but the proportion of each present varies with the curve considered. Hence different phases in the distillation of an oil can be shown by the infra-red absorption spectra.

(2) If the results obtained on each oil be carefully compared, a considerable difference is found to exist, hence further analysis is necessary in order to determine to what group the hydrocarbons in the two types belong

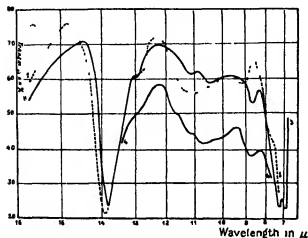

FIG 21

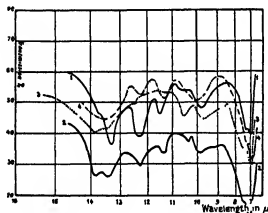

FIG 22

The presence in the spectra relative to the first oil (Fig 21) of an intense band at about 13.8μ and of a double band at 7μ equally intense with feeble maximum bands between them indicates the presence of a large percentage of cyclic hydrocarbons. This first oil contains but a small percentage of unsaturated hydrocarbons except for the bands between 10 and 11μ .

In the case of the second oil (Fig 22) on the contrary the proportion of cyclic hydrocarbons present is very small. It can be said that the substituted benzene hydro-

carbons with a lateral chain are practically absent, as are the benzene hydrocarbons substituted on the nucleus, since, if these latter were present, two intense bands would be found between 14 and 15μ , which is not the case. On the contrary it is certain from the existence of two bands 13.3 to 13.5μ and 12.3μ that hydroanthracenes are present (cf Table, Fig 16). In the case of the fractions 2,3,4 it is seen that between 13 and 14μ two bands exist and not a single band as in the case of the hydroanthracenes, and therefore it is concluded that other substances than these

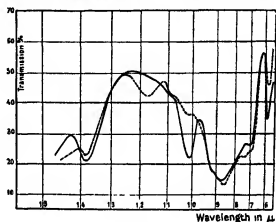

FIG 23

are present in the oil. It is thought that by comparing the spectra of different samples with those of the hydro-naphthalenes (cf Fig 15) that these hydrocarbons are the ones responsible and are therefore present.

In the second instance the absorption spectra of two vegetable oils have been examined namely, tung oil and soya-bean oil (Fig 23). The results obtained are very different from the preceding. The most characteristic feature is the appearance of an intense band at 5.9μ , which always accompanies the CO group in the aliphatic series, and a very complex band between 8 and 9μ . Tung oil possesses an intense band at 10μ which is not found with soya-bean oil and indicates the presence of ethylene linkages in the constituent molecules.

Conclusion

This brief paper gives the results obtained in France with the application of the infra-red absorption spectra in the study of petroleum spirits and oils. It is a method which is applicable in those large number of cases where physical and chemical methods of analysis are of no avail or are not sufficiently accurate.

SELECTED BIBLIOGRAPHY

ANDANT, A., LAMBERT, P., and LACOMTE, J. Application des spectres de diffusion (effet Raman) et d'absorption dans l'infrarouge à la distinction des cinq hexanes nombrés. *Compt rend* 196, 1316 (1934)

— Spectres de diffusion (effet Raman) et spectres d'absorption infra-rouges d'alcools saturés aliphatiques et de carbures éthyléniques. *Compt rend* 201, 391-3 (1935)

LAMBERT, P., and LACOMTE, J. Quelques applications des spectres d'absorption infra-rouges à l'étude des bulles et de leurs constituants. *Ann Combustibles liquides*, no 6, 1001-84 (1931)

— Spectres d'absorption infra-rouges de quelques carbures

anthracéniques. *Ann Combustibles liquides*, no 6, 979-93 (1934)

LAMBERT, P., and LACOMTE, J. Spectres d'absorption infra-rouges de quelques carbures anthracéniques II. *Ann Combustibles liquides* (1935)

— Contribution à l'étude des spectres d'absorption infra-rouges de carbures aliphatiques ou à noyaux. *Ann de Phys (Xème série)*, 18, 329-90 (1932)

— Spectres d'absorption infra-rouges de carbures benzéniques. *Compt rend* 194, 77-9 (1932)

— Spectres d'absorption infra-rouges de carbures à noyaux. *Compt rend* 194, 960-2 (1932)

- LECOMTE, J. *Contribution à l'étude l'absorption des rayons infra-rouges par les composés organiques* These, Paris, 1924
- Spectres d'absorption infra-rouges de dérivés cycliques *Compt rend* **183**, 27-9 (1926)
- Essai de coordination des bandes d'absorption infra-rouges de quelques carbures à noyau *Compt rend* **194**, 2037-9 (1932)
- Spectres dans l'infra-rouge *Traité de chimie organique* GRIGNARD, V., and BAUD, P. **2**, 143-293 (1935)
- LECOMTE, J., and LAMBERT, P. Quelques applications des spectres d'absorption infra-rouges à l'étude des constituants des essences (carbures à noyaux) *Publ. Sc. et techn. Ministère de l'air*, no 34 (1933)
- MILLER, O., and LECOMTE, J. Spectres d'absorption infra-rouges des ortho-diméthylcyclohexanes stéréoisomères *Compt rend* **198**, 812-14 (1934), *Bull. Soc. Chim. Belge*, **43**, 239-42 (1934)

THE APPLICATION OF THE X-RAY METHOD TO THE STUDY OF THE PARAFFIN HYDROCARBONS

By Professor F. FRANCIS and S. H. PIPER

University of Bristol

The study of the X-ray spacings of those members of the paraffin hydrocarbons which can be obtained in the crystalline condition can afford information on the arrangement in space of the molecules as well as their actual dimensions. The spatial arrangement of the molecules in the crystal will usually account for many of the properties of a substance and may suggest others, and clearly the size of the molecule can be used for purposes of identification. For work of this kind it is necessary in the first instance to investigate hydrocarbons which have been prepared in the highest possible state of purity.

Sources of the Hydrocarbons

One of the most satisfactory methods for preparing pure individual members of the higher normal paraffin hydrocarbons consists in the electrolysis of the alkali salts of the normal fatty acids. The degree of purity of such hydrocarbons clearly depends on that of the acids which are used. Stearic, palmitic, and behenic acids can be obtained in quantity, the last via the reduction of the ethyl ester of erucic acid, and with some little difficulty prepared in a high state of purity. The hydrocarbons synthesized from them, after further purification, probably do not contain more than 0.1% of impurities. Acids containing more than 22 carbon atoms can be obtained from behenic acid by well-known operations, and a recent method, by means of which acids containing more than 30 and 34 carbon atoms have been prepared, affords an entirely new process for their preparation [13, 1934, also 14, 1937].

Solid paraffin hydrocarbons occur widely distributed in the vegetable and animal kingdoms, but it is very doubtful whether pure individual members have ever been isolated from such sources, particularly when recent investigations employing X-ray methods have shown that hydrocarbons isolated from such materials are often mixtures of two or more individual members of the homologous series [11, 1931].

The chief commercial source of the solid paraffins is paraffin wax. The attempts which have been made to separate the components of paraffin wax are outlined below. There is no definite knowledge concerning the constituents of such naturally occurring solid hydrocarbons as ozokerite

Separation of the Components of Paraffin Wax

Kraft [6] investigated a Saxo-Thuringian wax, $m.p. 55-56^{\circ}C$, and believed that after five fractionations in a vacuum of the 'cathode rays' he had obtained eighteen hydrocarbons, and that the residue contained a further seventeen members, all of which were presumed to belong to the n -paraffin series.

Francis and his students [2, 1922] again investigated this problem, using a wax obtained by the distillation of Scotch shale fusing at $55-56^{\circ}C$. They subjected 950 g of this material to a systematic fractionation at low pressures which varied in different operations between 0.12 mm and 0.05 mm. The amount which distilled over at temperatures above

$240^{\circ}C$ at 0.05 mm did not amount to more than 2-3%. After seventeen fractionations they found that large amounts of material were obtained boiling over small ranges of temperature, and after twenty-one fractionations the operation was discontinued. The fractions isolated accounted for 88% of the original wax, and it was concluded that 80% of the wax was composed of seven hydrocarbons of constant boiling-point, and that the remaining 8% boiling between 220 and $240^{\circ}C$ probably contained not more than two others.

In a later communication the oxidation of these hydrocarbons was investigated at $100^{\circ}C$ with air [3, 1922], and from the velocity with which these processes proceeded, and from a study of the small amounts of hydrocarbons which in each case escaped this process, it was concluded that seven and possibly eight pure materials had been isolated from the paraffin wax that had been used.

The molecular weight of these hydrocarbons was determined by the ebullioscopic method which is not entirely reliable in such cases, but from such data it was concluded that the seven hydrocarbons were $C_{28}H_{58}$, $C_{34}H_{70}$, $C_{40}H_{82}$, $C_{46}H_{94}$, $C_{52}H_{106}$, $C_{58}H_{118}$, $C_{64}H_{130}$. Both the melting-points and the boiling-points under different pressures (Francis and Wood [5, 1926]) appeared to be identical with the corresponding data for the synthetic n -paraffins.

It was on these seven components that for the first time Piper, Brown, and Dymont [10, 1925] carried out a series of measurements of the X-ray crystal spacings. Although the identification of these individuals by this method was in general agreement with their carbon contents given above, later investigations with pure synthetic n -paraffins showed that all seven hydrocarbons contained impurities, probably in no case amounting to over 5%. The results, however, showed clearly that paraffin wax was composed of normal members of the paraffin series of hydrocarbons, and no indication was obtained of the presence of *iso* derivatives. Further support was given to this view by a close examination of the crystal spacings of a number of acids obtained by the oxidation of paraffin wax. In all cases these also belonged to the normal series of the fatty acids (Francis, Piper, and Malkin [4, 1930]).

The Application of X-ray Methods

Müller [7, 1928] made a thorough examination of a single crystal of nonacosane. The unit of pattern, or unit cell, from which the crystal is built consists of a very elongated rectangular prism of sides 7.45, 4.97, and 77.2 Ångström units ($1 \text{ Å unit} = 10^{-8} \text{ cm}$). The cell contains the substance of four molecules, whose relative dispositions are shown in Figs 1 and 2. The molecules themselves are flat zigzag chains, the length of the chains lying parallel to the long axis of the cell. The following important dimensions, whose significance can be seen in Figs 1, 2, and 3, were measured by Müller. The distance between the centres of two successive CH_2 groups on the same side of the chain axis (S in Fig 3) is 2.54 Å. units. The distance of nearest

approach between the centre of a CH_2 group in one chain and the corresponding group in its neighbouring molecule (D_1 in Fig 1) is 3.7 Å units. The cross-sectional area 'occupied' by one molecule is 18.5 sq Å units, and this molecular cross-section is found to be the same for crystals of any *n*-aliphatic compound. The distance of nearest approach between the axes of chains (D_2 in Fig 1) is found to be about 4.6 Å units in the solid state. The structure of the crystal is of an extremely open nature, the volume of the cell being about six times the volume of the atoms it contains.

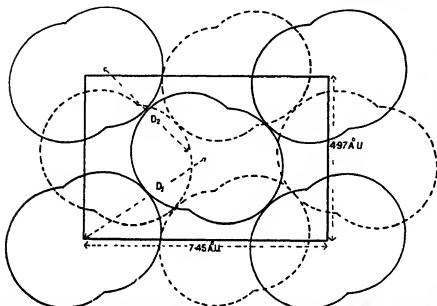

Fig 1 Packing of chains in planes perpendicular to their axes. Full figures are the cross-sections of molecules standing vertically up from the paper, broken figures are molecules pointing down.

Several important conclusions can immediately be drawn from a consideration of the structure. In the case of the higher members of the paraffins with an odd number of carbon atoms, it is found that the only variation in the crystal lattice dimensions occurs along the long (*c*) axis. The length of the *c* axis is in fact twice the length of the molecule plus twice the space between the ends of molecules. It is found that the length of the *c* axis (obtained from the 001 spacings of the crystal) increases linearly with the number of carbon atoms in the chain, so that the gap between the end groups of successive molecules measured in the *c* direction must be constant. The melting-points of the paraffins increase smoothly, but not uniformly, with chain length, and this increase in the force of cohesion must be attributed to the side-to-side attractions of the chains only. The end-to-end forces are comparatively small, and account for the flaky crystalline habit of the solid paraffins. The molecules stand perpendicular to the surfaces of the flakes like the pile on a carpet and, since the end-to-end attractions are small, slide easily over one another when pushed in a direction parallel to the flake surface. The molecules themselves are immensely strong, the expansion coefficient parallel to the chain axis being very small indeed (Müller [9, 1932]).

Variations in the Structure of the Unit Cell

The structure of the unit cell of all crystalline paraffins does not correspond to that of nonacosane, but depends on the length of the chain and the temperature, also, paraffins

containing odd and even numbers of carbon atoms differ in habit from one another. For instance, even-chain paraffins of from 24 to 36 carbon atoms crystallize from most solvents, when pure, with the chain axis tilted at an angle of about $61^\circ 30'$ to the flake surface, but are transformed into a modification characterized by a vertical chain and resembling that described for nonacosane at a temperature about 5°C below the melting-point (Piper and Malkin [12, 1930]). This transformation appears to be reversible for hexacosane, but not for the higher even paraffins (Piper, Chubb, *et al* [11, 1931]). The odd-chain hydrocarbons from 11 to 35 crystallize only with a vertical chain, whilst odd-numbered members from 5 to 9 and even-numbered from 6 to 22 again appear to have the axis tilted, but at an angle of about 73° . This third modification appears to transform reversibly to the normal (vertical) form a few degrees below the melting-point (Müller [8, 1930]). Müller has further shown that many paraffins tend to adopt yet another form just below the melting-point. The molecules are then packed in a hexagonal arrangement suggesting a cylindrical symmetry about the chain axis, and it is probable that the molecule is rotating about this axis. The X-ray measurements on the substance when just below its melting-point give a distance between the chain axes of 4.6 Å units, very nearly equal to that to be expected in the liquid state if all the chains were parallel, and it is therefore probable that an arrangement of parallel chains is adopted when the liquid is about to solidify.

Classification of the Crystal Modifications

It is convenient to classify the various crystal modifications of the paraffins by the letters *A*, *B*, and *C*. The *A* form has a vertical molecule, in the *B* and *C* forms the molecule is tilted, but slightly less in the *B* than in the *C* modification. Fig 4 gives measurements of the 001 spacings of a number of solid paraffins plotted against the number of carbon atoms in the chain. It is obvious that these measurements may be used as positive identifications of the pure compounds, but that care must be taken to ascertain which particular modification the compound had assumed when the photograph was taken. For instance, a pure, even-chain paraffin having 26 or more carbon atoms will, if crystallized from benzene, give a spacing falling on line *C*, but if it has been melted the spacing will be that on line *A*. Odd-chain paraffins of more than 9 carbon atoms will only give *A* spacings, since they do not crystallize in the *C* modification.

Crystals of Mixed I

The spacings and habit of the paraffins are profoundly modified by the presence of impurities. If a binary mixture of two paraffins is made it will, in general, have a spacing lying between those of the pure components, but not varying uniformly with the proportions of the mixture. The variation in general is more marked when a small propor-



FIG. 2 Side view of elementary cell of octadecane.

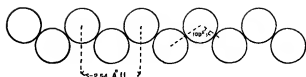

FIG. 3

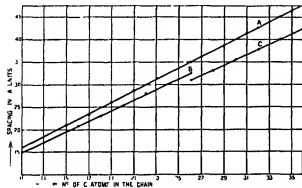

FIG. 4

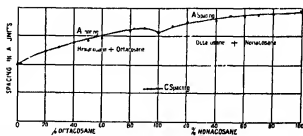

FIG. 5



FIG. 6 The top photograph is nonacosane. The five lower exposures are of nonacosane, the figures on the right of the plate giving the position of the oxygen atom as a fraction of the chain length. The spacing is the same throughout the set but the intensities of the reflections vary characteristically with the position of the oxygen atom.

tion of a longer chain is added to the shorter than in the reverse case. Fig 5 shows two typical cases. It has been found that a definite concentration of a second hydrocarbon in one of even carbon content causes it to crystallize in the *A* modification and not in the *C* form. This observation enables an estimation to be made of the lowest possible amount of impurity present in contaminated material. From the technique which has been evolved (Piper, Chibnall, *et al* [11, 1931]), the composition of mixtures of paraffins can be determined quantitatively from the spacings, melting-points, and temperatures at which transitions from one crystal form to another take place. This has been applied to determine the composition of many of the long-chain hydrocarbons isolated from plants or insects (Chibnall, *et al* [1, 1934]).

Earlier investigations by X-rays were carried out before the polymorphism of paraffins was understood. Later work, however, showed that the long-chain paraffins occurring in nature are always mixed, and that they consist, as far as they have been identified, of those containing an odd number of carbon atoms only.

The Position of Side Chains

A particularly beautiful application of the X-ray method, due to Shearer [15, 1924], enables the position of an oxygen atom in the chain of a ketone to be determined. The photographs obtained from paraffins consist of a series of evenly

spaced lines representing orders of reflection of the X-rays from a set of planes in the crystals. The planes concerned are those (parallel to the flake surface) which contain the ends of the molecules. Now if a keto-oxygen is added to each of the chains at the same distance from one end of the molecule, the side-chain atoms will also be in planes, interleaving those containing the ends of the molecules and parallel to them. This new distribution of matter does not alter the spacing of the planes in which lie the ends of the molecules, so that the lines on the photograph appear in the same positions as before, but their intensities are altered. In a paraffin the reflections normally decrease in intensity with increasing order. In ketones a periodic fluctuation is superimposed on this normal decline. The nature of the fluctuation is extremely simple, if the oxygen atom is half-way along the chain the 2nd, 4th, 6th, &c., or if the atom is at $1/3$ the length, the 3rd, 6th, 9th, &c., orders are very weak. The appearance of the photographs will be clear from Fig 6.

Liquid Hydrocarbons

The application of X-rays to the study of liquid members of the paraffin hydrocarbons has, so far, given but limited information. Those which have been investigated show a definite reflection corresponding to a spacing of 4.6 \AA , suggesting some parallelism in the chain axes, otherwise nothing but extensive disarrangement of the molecules can be deduced (Stewart [16, 1930]).

REFERENCES

- 1 CHIBNALL, A. C., *et al*. *Biochem J* **28**, 2189 (1934)
- 2 FRANCIS, F. *JCS* **121**, 1530 (1922)
- 3 ——— *JCS* **121**, 2805 (1922)
- 4 FRANCIS, F., PIPER, S. H., and MALKIN, T. *Proc Roy Soc. A*, **126**, 228 (1930)
- 5 FRANCIS, F., and WOOD, N. E. *JCS* **1420** (1926)
- 6 KRAFFT, F. *Ber* **40**, 4779 (1907)
- 7 MÜLLER, A. *Proc Roy Soc. A*, **120**, 437 (1928)
- 8 ——— *Proc Roy Soc. A*, **127**, 417 (1930)
- 9 MÜLLER, A. *Proc Roy Soc. A*, **136**, 514 (1932)
- 10 PIPER, S. H., BROWN, D., and DYMENT, S. *JCS* **127**, 2194 (1925)
- 11 PIPER, S. H., CHIBNALL, A. C., and DYMENT, S. *JCS* **125**, 2072 (1931)
- 12 PIPER, S. H., and MALKIN, T. *Nature*, **126**, 278 (1930)
- 13 ROBINSON, G. M. *JCS* **1543** (1934)
- 14 FRANCIS, F., KING, A. M., and WILLE, J. A. V. *JCS* **999** (1937)
- 15 SHEARER, G. *Proc Roy Soc. A*, **106**, 655 (1925)
- 16 STEWART, G. W. *Reviews of Modern Physics*, **116** (1930)

THE APPLICATION OF THE RAMAN EFFECT TO PETROLEUM CHEMISTRY

By JAMES H HIBBEN, D.Sc.

Geophysical Laboratory, Carnegie Institute of Washington

UNTIL nearly the last decade scientific developments in the petroleum industry have been confined chiefly to engineering achievements. Within the last few years, however, greater emphasis has been placed on the chemistry of petroleum. The development of new processes such as polymerization, hydrogenation, the production of by-products, and improved refinery methods has necessitated an increasing knowledge of the constitution of petroleum and the chemical and physical behaviour of its constituents. The petroleum industry, therefore, has only just begun to consider its problems from the point of view of a fundamental physical and chemical approach rather than the empirical treatments of the problems heretofore employed. While such methods have been less reluctantly embraced by other industries, the petroleum field has naturally been handicapped by the complexity of the system dealt with. One of the means of ascertaining this fundamental information is through the spectroscopic method termed the Raman effect.

There are certain results which may be obtained by this method which cannot be procured so readily by any other one. A brief discussion, therefore, of the nature of the Raman effect in its application and limitations is given in order to outline its possible utility in the petroleum industry.

The Raman effect is an optical phenomenon resulting from the interaction of a photon with a molecule. From this relatively simple mutual process, however, there can be derived considerable fundamental physical and chemical data. There is probably no other single physical manifestation which provides as much divergent information concerning the constitution of matter.

The Raman effect is independent of the state of aggregation, being applicable to gases, liquids, solids, solutions, and amorphous compounds. It results in no modification of either the chemical or the physical characteristics of the material examined, and is primarily concerned with the behaviour of the molecules in their normal states. It is therefore unique in the scope of its application.

The interpretation of the results of physical and chemical investigations must rest ultimately on a determination of the individual molecular and atomic components of a system as well as on a knowledge of their collective and individual behaviour. It is in the provision of such fundamental information concerning the molecule and molecular aggregates that the Raman effect has its greatest application.

More precisely the information which the Raman spectra method can provide may be summarized as follows: the determination of the vibrational and rotational levels which molecules possess, the forces of attraction between the atoms of the molecule, and the molecular configuration. Secondly this may result in the determination of the molecular symmetry, the arrangement of atoms in space, and consequently their valence angles, interatomic distances, and amplitudes of vibration. If these physical parameters can be estimated, then the chemical and the crystallographic properties may be determined at least partially. In cases

where molecular constitution is so highly complicated that a mathematical analysis or a quantum mechanical treatment is not possible, recourse may be had to empirical conclusions derived from an analysis of a multitude of Raman spectra investigations. This method of treatment is intrinsically as sound as any procedure based on statistical observations and carries the same weight as any experimentally determined fact.

From the point of view of practical application in the laboratory, the material to be examined is illuminated with a source of monochromatic light, and the light scattered by the molecules is recorded by a spectrograph. In addition to the line corresponding to the original illumination there will appear other lines called Raman lines or Raman shifts which depend upon the chemical constitution of the material illuminated. It is by means of the magnitude of the displacement of these lines, their intensities, and their degrees of depolarization that the molecules, molecular groups, or ions may be 'finger printed'.

In Fig 1 is a schematic diagram of apparatus used to obtain photographs of the Raman lines, and Fig 2 is a reproduction of a plate showing the Raman spectrum of orthoxylene.

The exciting radiations and the Raman radiations are usually characterized by their 'frequency' which is a term used loosely to mean the reciprocal of the wave-length in centimetres. This 'frequency' is therefore not the vibration frequency in cycles per second, but the number of waves per centimetre. This is given by the expression

$$\bar{\nu} = 10^8/\lambda_s \quad (1)$$

where $\bar{\nu}$ is expressed in the number of waves per centimetre and λ the wave-length of the spectral lines in Ångström units. The Raman shifts are obtained from the following relation

$$\bar{\nu}_1 - \bar{\nu}_2 = \pm \Delta\bar{\nu} \quad (2)$$

where $\Delta\bar{\nu}$ is the Raman shift or the Raman 'frequency' expressed in number of waves per centimetre. For the simplest case, namely, a diatomic oscillator, one atom will oscillate against the other in much the same manner as two balls attached by a spring will oscillate. The frequency of oscillation will depend upon the weight of the balls and the strength of the spring. For a linear triatomic system there are three possible motions as represented by Fig 3 in which II represents the symmetrical oscillation, I asymmetrical oscillation, and III the deformation oscillation. As a first approximation in a diatomic system the relation between the Raman frequency and the force binding the atoms and the molecules are the same as an equivalent mass and force system in a simple mechanical model and obey the equation for a simple harmonic oscillator

$$\Delta\bar{\nu} = 4.25 \cdot (F/\bar{\mu}) \quad (3)$$

where $\Delta\bar{\nu}$ represents the Raman frequency, F the force constant, and $\bar{\mu}$ the reduced mass. In applying equation (3), for example, to the group oscillations (where specific

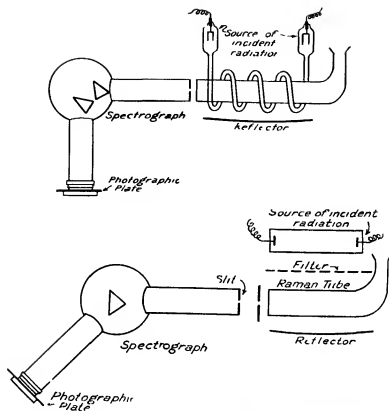

FIG. 1 Diagrams of apparatus used in Raman effect determinations.



FIG. 2 The Raman spectra of ortho xylenol.

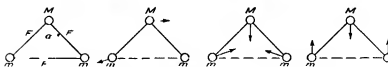

FIG. 3 Types of possible vibrations in non-linear triatomic molecules.

[10, 1933, 15, 1930] The table illustrates not only the $C\alpha-H$ oscillation in this type of compound but also indicates that the frequency shift corresponding to $C=C$ may vary from $\Delta f 1,598$ to $\Delta f 1,647$. Nevertheless, this frequency

TABLE II
Raman Shifts characteristic of $C=C$ and other Shifts common to Olefines

Substance	Δf		
$CH_2=CH$ H	1,340	1,620	3,000
$CH_2=CH$ CH_2	1,295	1,614	3,007
$CH_2=CH$ C_2H_5	1,294	1,616	3,003
$CH_2=CH$ C_3H_7	1,296	1,616	3,001
$CH_2=CH$ C_4H_9	1,295	1,616	3,002
$CH_2=CH$ C_5H_{11}	1,299	1,616	3,000
$CH_2=CH$ C_6H_{13}	1,296	1,616	3,001
$CH_2=CH$ C_7H_{15}	1,296	1,613	3,006
$CH_2=CH$ C_8H_{17}	1,300	1,616	3,003
$CH_2=CH$ CH_2-C C_6H_5	1,416	1,642	3,081
$CH_2=CH$ CH_2OH	1,290	1,616	3,014
$CH_2=CH$ $CHOH$ CH_3	1,287	1,616	3,013
$CH_2=CH$ CHO	1,277	1,563	3,018
$CH_2=CH$ CO_2H	1,288	1,597	3,038
$CH_2=CH$ Cl	1,271	1,555	3,036
$CH_2=CH$ $CHCl$	1,291	1,611	3,022
$CH_2=CH$ Br	1,251	1,569	3,015
$CH_2=CH$ CH_2Br	1,295	1,609	3,016
$H_2C=CH$ $CH=CH_2$	1,277	1,636	3,000
H_2C $CH=CH$ $CH=CH_2$	1,288	1,643	3,000
$H_2C=C(CH_3)$ $CH=CH_2$	1,291	1,620	3,012

is sufficiently characteristic to allow it to be readily identified in the presence of any mixture of saturated aliphatic hydrocarbons. The identifying Raman lines attributed to $C=O$ are deducible from the following table [16, 1930, 34, 1933]

TABLE III
Frequencies Characteristic of $C=O$

Substance	Δf				
	H_2C CO X	R H_2C CO X	R_2HC CO X	R_2C CO X	C_6H_5 CO X
Acid, $X=OH$	1,666	1,652	1,648	1,644	1,647
Methyl ester, $X=OCH_3$	1,736	1,735	1,732	1,728	1,720
Ethyl ester, $X=OC_2H_5$	1,736	1,732	1,728	1,724	1,721
Ketone, $X=CH_3$	1,710	1,709	1,709	1,702	1,677
Acid chloride, $X=Cl$	1,798	1,793	1,788	1,790	
Aldehyde, $X=H$	1,715	1,719	1,719	1,723	1,689

TABLE IV
Carbonyl Frequency in Esters of Type $XCOOR$

Substance	Δf						
	$X=H$	$X=Cl$	$X=CH_3$	$X=CH_2Br$	$X=CH_2Cl$	$X=CHCl_2$	$X=CCl_3$
1 $R=CH_3$	1,717	1,780	1,738	1,740	1,748	1,755	1,768
2 $R=C_2H_5$	1,715	1,772	1,736	1,738	1,747	1,750	1,763
3 $R=C_3H_7$	1,719	1,775	1,739	1,736	1,742	1,749	1,764
4 $R=C_4H_9$	1,718	1,773	1,737	1,732	1,739	1,751	1,765
5 $R=C_5H_{11}$	1,718	1,774	1,738		1,744	1,756	1,769

From this it may be seen that the actual numerical value of the carbonyl shift depends upon the nature of the adjacent group. If that group be changed to a halogen, alcohol, ester, or unsaturated hydrocarbon radical, there is a marked change in the Raman frequency. If, however, the group in the α position is a hydrocarbon radical, the change is less marked. This behaviour is shown further in a series of esters in which both the ester radical and the α substituent group are varied. This demonstrates that a change in the ester radical has little or no effect on the carbonyl frequency, but the change in the character of

the other adjacent radical modifies the carbonyl frequency. These results are indicated in Table IV [12, 1934].

For triply bonded carbon a unique frequency exists due to the high value of the force constant. This is in the region of $\Delta f 2,118$ for monosubstituted acetylene and $\Delta f 2,238$ for disubstituted acetylene. The constancy of these values within a group is indicated in Table V [11, 1930, 24, 1935].

A change in the composition of one substituent group in monosubstituted or disubstituted acetylene does not alter the frequency, but going from a monosubstituted derivative to a disubstituted derivative profoundly alters the spectra. Apparently in a triple-bonded compound the attractive force between the two carbon atoms is more easily influenced by changes in the α position than either singly or doubly bonded carbon.

It has been shown thus far that the ordinary linkages encountered in the chemistry of aliphatic organic compounds have identifying shifts. Furthermore, group oscillations or so-called outer vibrations can be delimited within certain ranges. The next types of compound pertinent to the chemistry of petroleum are the cyclic compounds. The first of these to be considered are the simplest ones, namely, cyclopropane and its derivatives. Cyclopropane has a characteristic shift $\Delta f 1,188$ which increases to $\Delta f 1,228$ in methylpropylcyclopropane and has intermediate values for substituents of less molecular weight. This becomes split into a double frequency when two substituents of unequal weight are present. In addition to the relatively constant frequency there is another Raman shift which progressively decreases with increased substitution.

TABLE V
The Characteristic Raman Shift for $C\equiv C$

Substance	Δf	Substance	Δf
$(CH_3)_2C_2H_2$	2,118	$CH_3C\equiv CCH_3$	2,238
$C_6H_5C_2H_2$	2,119	$C_6H_5C\equiv CCH_3$	2,238
$C_6H_5C_2H$	2,111	$C_6H_5C\equiv CC_6H_5$	2,233

Curiously enough this frequency decreases at a rate approximately inversely proportional to the square root of the number of carbon atoms [39, 1932], and is illustrated

in Fig 5 The hydrogen to carbon vibrations in cyclopropane correspond to Δf 3,015-3,029 and 3,076 The first band approaches Δf 3,000 and the weak line, Δf 3,076, decreases to Δf 3,061, but with increasing intensity as the molecular weight of the cyclopropane derivatives are increased

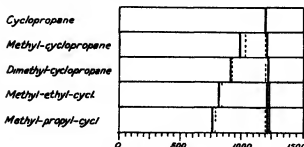

Fig 5 The change in the lower frequency shift of the C-C oscillation in cyclopropane and some of its derivatives

Aromatic compounds are naturally of considerable interest Benzene has been investigated more thoroughly

TABLE VI
Characteristic Frequency Shifts of Benzene and Mono-substituted Derivatives

Substance	Δf					
	605	992	1,178	1,604	3,050	3,050
C ₆ H ₆				1,604	3,050	3,060
C ₆ H ₅ CH ₃	622	1,002	1,029	1,154	1,208	1,585
C ₆ H ₄ CH ₂ CH ₃	620	1,003	1,029	1,157	1,203	1,604
C ₆ H ₃ C ₂ H ₅	611	994	1,022	1,146	1,191	1,589
						3,047
						1,608
C ₆ H ₅ CH ₂ C ₂ H ₅	623	1,012	1,037	1,145	1,175	1,593
C ₆ H ₄ CH ₂ Cl	619	1,000	1,034	1,159	1,211	1,600
C ₆ H ₃ C ₂ H ₅ OH	610	1,000	1,029	1,170	1,196	1,594
C ₆ H ₄ OH	614	1,001	1,023	1,170	1,208	1,598
C ₆ H ₅ CHO	615	1,000	1,022	1,163	1,203	1,597
C ₆ H ₄ CO Cl	615	1,003	1,028	1,168	1,206	1,592
C ₆ H ₃ CO ₂ CH ₃	615	1,000	1,023	1,160	1,202	1,602
C ₆ H ₄ CO CH ₃	615	999	1,025	1,155	1,198	1,598
C ₆ H ₃ Cl	615	1,001	1,021	1,156	1,191	1,581
C ₆ H ₄ Br	608	1,000	1,022	1,159	1,176	1,576
C ₆ H ₅ I	610	998	1,012	1,158	1,168	1,568

than any other organic compound A large number of lines have been recorded for benzene [22, 1933] Grassmann and Weller come to the conclusion that of the 41 measured lines, 10 are fundamental frequencies, and the rest are combinations The fundamental frequencies are Δf 400, 606, 692, 849, 992, 1,034, 1,176, 1,480, 1,585, 1,606, 3,049, 3,063. In Table VI [10, 1933, 18, 1932] are given the more or less constant frequencies observed in benzene and its monosubstituted derivatives, and in Table VII [33, 1934], the change in the C=C vibration of benzene and its derivatives as a function of substitution. The frequency shifts thus far presented form only a few of the types of bodies which have been investigated systematically. There is practically no type of organic compound which has not received some attention This pertains not only to organic,

but also to inorganic compounds such as acids, bases, salts, crystals, and gases, the results of which have been summarized by Hibben [29, 1933] In Fig 6 are given the comparison spectra of a series of organic compounds

With this accumulation of data before us, the question arises from the point of view of petroleum chemistry, What can be done with it? This has already been stated, but a few examples will be pertinent From the point of view of identification Lespiau, Bourguet, and Wakeman [38, 1931] were able to identify less than 1% of impurity of an

TABLE VII
The Change in C=C Shift as a Function of Substitution in Polysubstituted Benzene

Substance	Position	Δf	
		X=Cl	X=CH ₃
C ₆ H ₆		1,584	1,606
C ₆ H ₅ X	1	1,580	1,580
	1, 2	1,572	1,584
	1, 1	1,572	1,590
	1, 4	1,572	1,575
	1, 2, 4	1,564	1,567
	1, 3, 5	1,563	1,604
	1, 2, 3	1,554	
	1, 2, 4, 5	1,563	1,560
	1, 2, 3, 5	1,558	1,572
	1, 2, 3, 4	1,552	
	1, 2, 3, 4, 5	1,553	1,572
	1, 2, 3, 4, 5, 6	1,503	1,565

ethylenic type in hydrocarbon mixtures of cyclopropanes. If in a mixture of organic compounds one component possesses a line unique so far as the rest of the constituents are concerned, that component can be reasonably estimated quantitatively, as the Raman effect is proportional to the concentration An example of the photometric study of binary mixtures is found in the quantitative estimation of benzene and toluene by Criger [13, 1932]. This is illustrated in Fig 7

Since the shift corresponding to C=C is not only unique but a function of constitution, the concentration of *cis*- and

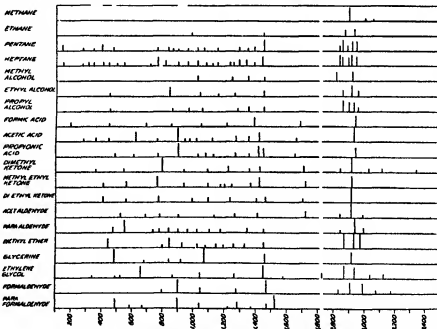

Fig. 6 Comparison spectrum of a variety of hydrocarbons and derivatives

trans-isomers may be readily determined. The basis upon which this is predicated is indicated as follows

R	$\Delta\bar{\nu}$		
	$\text{CH}_2=\text{CHR}$	$\text{CH}_3\text{CH}=\text{CHR}$	
		<i>cis</i>	<i>trans</i>
C_6H_5	1,642	1,658	1,674
C_6H_5	1,642	1,658	1,674
RCH_2	1,635	1,651	1,666
CH_2OH	1,646	1,658	1,677

Gredy and Piaux [26, 1934] further observed $\Delta\bar{\nu}$ 1,625 for the *cis* form of croton aldehyde and $\Delta\bar{\nu}$ 1,642 for the *trans* crotyl alcohol yields $\Delta\bar{\nu}$ 1,658 *cis* and 1,679 *trans*. The *cis* and *trans* forms of stereo-isomers can be determined. Miller

Raman effect is in the study of enol-keto tautomerism. In Fig 8 is shown a comparison between the lines obtained from butadiene, ethylacetate, acetone, and a mixture of the enol and keto forms of ethyl acetoacetate [15, 1930, 35, 1934]. The double bond corresponding to the C=C in the enol form is clearly in evidence, and the two lines corresponding to ketonic carbonyl and ester carbonyl are likewise present. The possibility of isomerism in aldo has been indicated by Hibben [31, 1936, 28, 1932] as well as the existence of methylene glycol in aqueous solution. In the latter case the well-established shift $\Delta\bar{\nu}$ 1,768 for formaldehyde disappears progressively as water is added to a solution containing a molecular excess of formaldehyde [27, 1931].

Perhaps one of the most fruitful applications of the Raman effect lies in the field of the terpenes. The mixtures

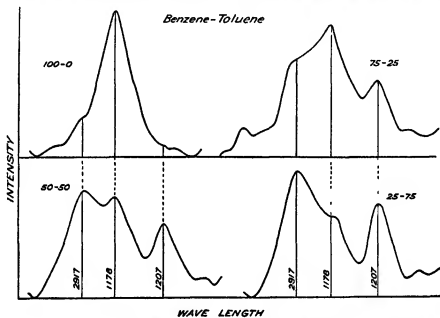
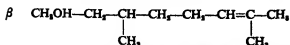
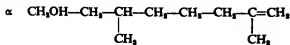

Fig 7 The relative intensities of specific Raman lines in benzene and toluene mixtures as a function of concentration. (After Czigler)

and Lecomte [40, 1934] have shown that the two lines at $\Delta\nu$ 440 and 498 only represent the *trans* form of orthodimethylcyclohexane and at $\Delta\bar{\nu}$ 333 uniquely in the *cis*. This is in agreement with other observers [41, 1933, 21, 1932]. An example of the delimitation of structure in a mixture is in the observations of Gredy [23, 1932], and of Naves, Brus, and Allard [42, 1935] on the isomerism of rhodinol and citronellol. This exists in two forms



It was found that compounds of the type 2-methyl-1-octene yield $\Delta\bar{\nu}$ 1,647 and compounds of the type 3-methyl-2-nonene yield $\Delta\bar{\nu}$ 1,672. These are analogous to the α and β forms. Citronellol gives $\Delta\bar{\nu}$ 1,677 with a very faint line at 1,645, and from this it is probably correctly concluded that in these compounds the β form is very largely predominant. Another interesting example of the application of the

found and the complication of the structures are more nearly analogous to the problems presented in the petro-

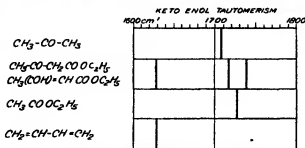

Fig 8 The enol and keto forms of ethyl acetoacetate. (After Andrews)

leum industry than almost any other field of organic chemistry. This field of investigation is still in its infancy. Let us consider, however, some of the progress made so far. The shift $\Delta\bar{\nu}$ 3,010 has been ascribed to the carbon hydrogen

linkage of the group $\text{C}=\underset{\text{H}}{\overset{\text{H}}{\text{C}}}$ [14, 1930]. This is found in

carvomenthene, cyclohexene, and isosilylbenzene [37, 1930], which is not consistent with this deduction as these compounds have no $=CH_2$ groups. This shift occurs in a few terpenes. The spectra from limonene and carvomenthene are very similar. Dupont, Daure, Allard, and Levy [19, 1932] have analysed a mixture of terpenes by means of the Raman effect. Pinene and β -pinene have many lines in common. The ring double bond of pinene, however, gives ΔF 1,672 and the exterior double bond ΔF 1,641. Beta-pinene shows ΔF 879 which is absent in pinene. Carene yields a frequency corresponding to the $C=C$ of 1,695. Pionene and nopinane unfortunately give identical Raman frequencies. Camphene yields ΔF 1,672 for the double bond

The analysis of the essence of terpenes, *Pinus longifolia*, by Raman spectra leads to the conclusion that there are present two forms of carene, namely, Δ^2 -carene and β -carene [20, 1932]. The distillation of oil of indienne likewise has been followed and shows the presence of pinene, β -pinene and Δ^2 -carene in successive distillates. Bonomo and Cella [8, 1931, 9, 1932] have made exhaustive studies of the terpenes and their derivatives and have tabulated the distinguishing characteristics of these compounds. In Fig 9 is the comparison spectrum of some of the terpenes.

The actual application of the Raman effect directly to the petroleum problems is as yet meagre. Andant [1, 1933, 2, 1933, 3, 1934] and Hibben [28, 1932, 30, 1934] have dis-

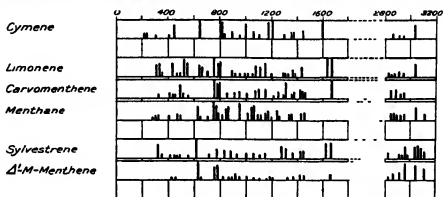

FIG 9 Some characteristic shifts of terpenes (After Dupont, Daure, Allard, and Levy)

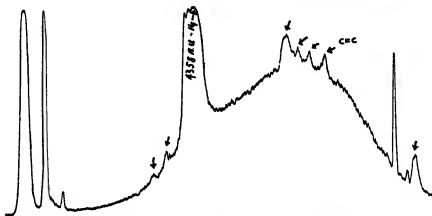

FIG 10 A microphotometric tracing of a cracked gasoline spectrum showing the presence of olefinic linkage

identical with pinene. There are, however, other lines which enable it to be distinguished from the latter. Menthane and limonene yield ΔF 1,691 for the ring double bond. Bonichon [7, 1934] has investigated a large number of alcohol and ester derivatives of terpenes. It is evident that there are enough distinguishing lines to differentiate the esters of a given terpene from each other and to determine the composition of mixtures of such closely allied compounds as the spacial isomers borneol and isoborneol. Borneol shows the characteristic rays ΔF 600, 1,230, 1,300, and isoborneol ΔF 627, 857, and 1,023. The structures of these two compounds are indicated as follows:



cussed this phase of Raman spectra. The approach here is essentially the same as that already outlined. First, the determination of the spectra of compounds likely to be present in the petroleum samples and the correlation of the Raman spectra of the petroleum with these results. It is obvious from the discussions so far that the diolefines, olefines, cyclohexanes, and benzene derivatives can be estimated in reasonably wide cuts. A simplified illustration of this is shown in the microphotometric tracings of the Raman spectra of cracked gasoline, Fig 10. If mercaptans or oxygenated compounds are present in excess of a few per cent, these can also be distinguished. A more complicated problem, however, is the determination of the composition of mixtures containing quite a few components. Andant has measured the Raman spectra of a number of pure compounds and mixtures which might occur in petroleum fractions.

The Raman method is no substitute for ordinary procedures which will more easily yield desired information. The application to raw petroleum materials such as oil is scarcely feasible first, because the colour absorbs both the exciting radiation and Raman lines, second, because of intense fluorescence, and last, because of the complexity of material. Nevertheless, some of the lines can be obtained from oil. There are, however, many possible examples where ordinary analysis of mixtures is difficult. In such cases and in the determination of the constitution of organic compounds this process is particularly applicable.

In this brief discussion of the Raman effect only a small portion of the accumulated data, interpretations, and applications have been given. Its relation to thermo-chemistry,

crystallography, and spectroscopy has been omitted entirely. It has not been possible within the scope of this article to discuss the other parameters which define Raman spectra—depolarization factors and intensities. This entire presentation has been dealt with elsewhere [31, 1936]. Nevertheless, the origin of Raman spectra has been discussed and some of the evidence used in determining the structure of molecules and the composition of mixtures presented. While it cannot be over-emphasized that there are definite limitations to its use in petroleum chemistry, it is clearly a valuable adjunct, and if petroleum research is to develop on a more fundamental chemical and physical basis, this is a method which can scarcely be ignored.

REFERENCES

- 1 ANDANT, A. *Chim et Ind* 480, Special number (June 1933)
- 2 ——— *Publications scientifiques et techniques du Ministre de l'Avr*, no 21, 1 (1933)
- 3 ——— Reprint from *Proceedings of the 14th Congr of Industrial Chemistry*, Paris, October 1934
- 4 ANDREWS, D H. *Phys Rev* 34, 1626 (1929)
- 5 ——— *Phys Rev* 36, 544 (1930)
- 6 ANDREWS, D H., and MURRAY, J W. *J Chem Physics*, 2, 634 (1934)
- 7 BONCHON. *Bull inst pin* 32 (1934)
- 8 BONINO, G B., and CELLA. *Mem accad Italia Chim* (4) 2, 5 (1931)
- 9 ——— *Mem accad Italia Chim* (4) 3, 5 (1932)
- 10 BOURQUEL, M. *Bull soc chim* 53-4, 469 (1933)
- 11 BOURQUEL, M., and DAURE, P. *Bull soc chim* 47, 1349 (1930)
- 12 CHENG, H C. *Z physik Chem B* 24, 293 (1934)
- 13 CHIGLER, E A. *J A C S* 54, 4207 (1932)
- 14 DADIEU, A., and KOHLRAUSCH, K W F. *Ber* 63, 251 (1930)
- 15 ——— *Ber* 63, 1657 (1930)
- 16 ——— *Monatsh* 55, 58 (1930)
- 17 ——— *J Optical Soc Amer* 21, 286 (1931)
- 18 DADIEU, A., FONGATZ, A., and KOHLRAUSCH, K W F. *Monatsh* 60, 221 (1932)
- 19 DUPONT, G., DAURE, ALLARD, J., and LEVY, J. *Chim et Ind* 630, Special number (March 1932)
- 20 DUPONT, G., and JOFFRE. *Chim et Ind* 638, Special number (March 1932)
- 21 GOCCHOT, M., CANALS, E., and CAUQUIL, G. *Compt rend* 194, 176 (1932)
- 22 GRASSMANN, P., and WEILER, J. *Z Physik*, 86, 321 (1933)
- 23 GREY, B. *Compt rend* 195, 313 (1932)
- 24 ——— *Ann chim* 4, 5 (1935)
- 25 ——— *Bull soc chim* 2, 1029 (1935)
- 26 GREY, B., and PIAUX, L. *Compt rend* 196, 1235 (1934)
- 27 HIBBEN, J A. *J A C S* 53, 2418 (1931)
- 28 ——— *Proc Nat Acad Sci* 18, 532 (1932)
- 29 ——— *Chem Rev* 13, 345 (1933)
- 30 HIBBEN, J A. *Ind Eng Chem* 26, 646 (1934)
- 31 ——— *Chem Rev* 18, 1 (1936)
- 32 KETTING, C F., SHUTTA, L W., and ANDREWS, D H. *Phys Rev* 36, 531 (1930)
- 33 KOHLRAUSCH, K W F. *Naturwissenschaften*, 22, 181 (1934)
- 34 KOHLRAUSCH, K W F., and PONGATZ, A. *Ber* 66, 1355 (1933)
- 35 ——— *Ber* 67, 976 (1934)
- 36 LECHNER, F. *Sitzber Akad Wiss Wien, Abt IIa*, 141, 291 (1932)
- 37 LEPICHAU, R., and BOURQUEL, M. *Bull soc chim* 47, 1365 (1930)
- 38 LEPICHAU, R., BOURQUEL, M., and WAREMAN, R L. *Compt rend* 193, 238 (1931)
- 39 ——— *Bull soc chim* 51, 400 (1932)
- 40 MILLER, O., and LECOMTE, J. *Compt rend* 198, 812 (1934)
- 41 MILLER, O., and PIAUX, L. *Compt rend* 197, 412 (1933)
- 42 NAVES, Y R., BRUS, G., and ALLARD, J. *Compt rend* 206, 1112 (1933)
- 43 RADAKOVIC, M. *Monatsh* 60, 239 (1932)
- 44 ——— *Sitzber Akad Wiss Wien, Abt IIa*, 141, 41 (1932)
- 45 TERT, D E., and ANDREWS, D H. *J Chem Physics* 3, 175 (1935)
- 46 TRENKLER, F. *Physik Z* 36, 162 (1935)
- 47 ——— *Physik Z* 36, 423 (1935)
- 48 TRUMPF, B. *Z Physik* 62, 806 (1930)
- 49 YATES, R C. *Phys Rev* 36, 555 (1930)
- 50 ——— *Phys Rev* 36, 563 (1930)
- 51 ——— *Phys Rev* 37, 616 (1931)

BIBLIOGRAPHY

- KOHLRAUSCH, K W F. *Der Smekeal-Raman Effekt*. Verlag von Julius Springer (Berlin, 1931)
 DAURE. *Introduction à l'étude de l'effet Raman*. Éditions de la revue d'optique théorique et instrumentale (Paris, 1933)

ANALYSIS OF PETROLEUM SPIRITS USING THE RAMAN SPECTROGRAPH

By A ANDANT

This article discusses the use of the Raman spectrograph in the analysis and rapid identification of the hydrocarbons contained in petrols when more than 2 or 3% are present

The optical phenomenon utilized is as follows: If intense monochromatic light radiations of frequency N , be optically concentrated in a liquid and a photograph then be taken of the light diffused by this liquid at an angle of 90° , it will be observed that besides the brightly defined line corresponding to the exciting rays, there are numerous other rays the position and intensity of which depend on the chemical characteristics of the diffusing liquid. In the case of a mixture of pure substances in sufficient proportion, each of the constituents give their own particular rays, there is never any fogging of the rays from each component. For example, all the chemical bodies containing the benzene nucleus give a Raman spectra of 5 rays, the positions in the spectra of which are in the same order, and the position of the chemical groups in the molecule can be determined by these rays and the presence of the benzene nucleus identified. The most intense ray identifies the benzene nucleus. The positions of the rays in the Raman spectra are characterized by the difference between the frequency of the exciting ray and the frequency of the Raman ray and not by the frequency of the Raman ray itself. These frequencies are usually expressed in terms of the reciprocals of the wave-lengths in centimetres, instead of in cycles per second, and their difference or the Raman 'shift' is therefore also in terms of number of waves per centimetre (cm^{-1})

This difference or 'shift' is spoken of somewhat loosely as the Raman 'frequency'. For instance, the intense benzene ray previously mentioned has a 'frequency' of 995 cm^{-1}

The apparatus necessary to study the Raman effect consists of an intense light source giving monochromatic radiations, a cell in which the liquid to be examined is placed, and a spectrographic camera. For the source of light the most convenient form to use is the mercury-arc lamp, the light from which is projected into the liquid by a large objective lens. The liquid is contained in a small glass cell as shown in Fig 1. The plain face of the cell is placed against the luminous slit of the spectrometer. For each liquid, photographs of two spectra are obtained, one using an indigo exciting ray of wave-length $4,360 \text{ \AA}$, and isolated by filtering the light through a sodium-nitrite solution, and the other the indigo-violet of wave-length $4,047 \text{ \AA}$, isolated by using cupric ammonium sulphate solution as the filter.

The first spectra gives the Raman rays of frequencies lower than 200 cm^{-1} and the other those rays of greater frequencies (Fig 2)

In order to obtain rapidly the relative spectra of various distillates, the following method was adopted. On the negative film on which the rays are recorded an accurate millimetre grid in glass was placed, and the position of the various Raman rays were noted and compared with the standard ray. These readings were referred to a curve of the Raman spectra obtained originally with pure substances and registered in a similar manner, the frequency of each ray was then directly read off. The reference mark for the position of the grid on the curves was made by using a

mercury exciting ray. The accuracy obtainable with this method is of the same order as with the previous method (i.e. 2 to 3 cm^{-1}) but the length of time required is considerably shorter

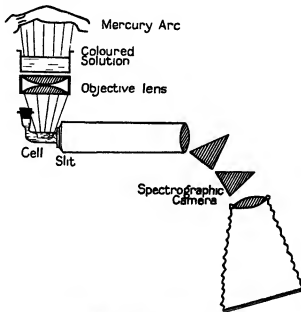

Fig 1 Arrangement of the apparatus for obtaining the Raman spectra

Identification of Impurities in a Hydrocarbon.

The identification of an impurity present in a small proportion in a hydrocarbon, is made by means of the rays peculiar to the impurity, and comparing with the complete spectra of the constituting body (Fig 3). Two samples of cyclohexene, one prepared by dehydration of commercial cyclohexanol, with sulphuric acid, and the other by dehydrating pure cyclohexanol with zinc chloride, gave true Raman spectra, which differed in frequency at about $1,600 \text{ cm}^{-1}$, the spectra of the first hydrocarbon gave two intense rays $1,605-62$, which have never been found to exist with pure cyclohexene. The Raman spectra of a mixture of pure cyclohexene with 10% of pure cyclohexadiene gave similar lines to that of the prepared cyclohexene, the impurity was therefore cyclohexadiene. This arose from the fact that impure cyclohexanol had been used in the preparation, it had been prepared by hydrogenation of phenol containing diphenols and hence giving diols and finally the corresponding ethylene hydrocarbons. It has been possible to determine the extent of the impurity in the mixture examined by obtaining the Raman spectra of three mixtures of pure cyclohexene with 5-10 and 20% of cyclohexadiene, the impurity present was found to be between 10-20%. The precise figure could be obtained by taking intermediate mixtures, e.g. 10-14-16 and 18% (Fig 4 shows spectra for the foregoing)

A Study of the Fractions obtained by Distillation of Hydrocarbon Mixtures.

Before testing unknown spirits, known mixtures were prepared and then fractionally distilled.

A study of a mixture of two hydrocarbons with almost similar boiling-points, namely benzene and hexane, was made. This mixture was slowly fractionated, using a column, and three fractions were collected at 70° C., 72° C., and 75° C. Three Raman spectra were obtained on the same plate and hence the course of the distillation followed. In the spectrograph of the 70° C. fraction the rays were very feeble, showing that benzene existed in the distillate, but in a very small proportion, on the other hand, the spectrograph of the 75° C. fraction showed well-defined exciting rays, and hence the quantity of benzene in the distillate was large (Fig 5). This case is that of an azeotropic mixture, the two constituents having boiling-points different to those obtained in the distillation, namely, 68.9° C. for hexane and 80.5° C. for benzene.

The Constituents of Spirits.

The following method was adopted for determining the nature of the constituents of a specimen spirit. The spirit was distilled in an apparatus fitted with a Robert's column and fractions collected at regular temperature intervals of from 4 to 5° C. Photographs of the Raman spectra of each fraction then gave the characteristic frequencies of all the rays obtained. By comparing the boiling-points of each fraction with the frequency of the corresponding Raman rays and also with the Raman spectra of the pure hydrocarbons thus then gave the exact constituents of the mixture. If one hydrocarbon is present in a very small proportion then it can only be identified by its more intense rays. This is often the case with benzene, cyclohexane, and ethylenic and acetylenic hydrocarbons.

Fractions of Various Spirits Distilling at the Same Temperatures.

If the Raman spectra of fractions to 100° C. of four different spirits be observed, very different results are obtained. For example, Pechelbronn spirit gives rays characteristic of heptane and related saturated hydrocarbons, there are no benzenoid or cyclic hydrocarbons indicated. The fraction corresponding to commercial lignin gives marked rays characteristic of methylcyclohexane and few characteristics of heptane. The spectra obtained from a Mid-Continent petroleum are very similar to the preceding but with a more marked indication of the presence of benzene. Finally, the fraction obtained between 95° C. and 100° C. of a Brandon spirit gives very complex spectra and much methylcyclohexane is present with very little toluene or associated hydrocarbons. Identical differences are observed with fractions obtained at about 145° C. Pechelbronn spirit gives at 142° C. a fraction rich in saturated hydrocarbons and containing a small quantity of methylcycloheptane, but no xylenes. The corresponding fraction of a Mid-Continent spirit does not apparently contain any xylenes but only saturated hydrocarbons. A very marked ray is noticeable at about 1,000 cm^{-1} showing the presence of ethyl benzene. Contrary to the preceding samples the fraction of the Brandon spirit distilling between 140° C. and 145° C. appears to be very rich in xylenes, giving intense rays in the neighbourhood of 1,625 cm^{-1} , each of the isomers has been identified. Saturated hydrocarbons are recognized by a group of rays

situated at about 1,450 cm^{-1} , in the spectra are also found some rays corresponding to mesitylene.

Identification of Isomers present in Fractions of Narrow Boiling Range.

A detailed study of the fractions obtained from Brandon spirit allows the isomers to be separated, it is perhaps the most interesting case where the Raman spectra method has been used. The isomers are obtained in successive fractions at 135–140° C., 140–145° C., and 145–150° C. In the first fraction para- and meta-xylenes have been found the rays corresponding to *m*-xylene being more intense than those of the para-isomer. There is therefore a greater proportion of *m*-xylene present and no *o*-xylene. The numerical results on this fraction are given below.

The frequencies given in the first column are the mean of the results obtained by various authors. The sign * indicates that the rays are common to several constituents.

<i>n</i> -Xylene		<i>p</i> -Xylene	
532	531	455	454
738	725	825	825
1,000	998*	1,200	1,203
1,245	1,247	1,387	1,382
1,375	1,377*	1,618	1,618
1,448	1,448		
1,603	1,605		
2,917	2,920*	2,920	2,920*
3,043	3,050*	3,043	3,050*

For the 140–145° C. fraction the characteristic rays of *m*- and *p*-xylene are feeble in the corresponding spectra. The proportion of each of the hydrocarbons present has therefore diminished and a comparison of the relative intensities of the rays shows that *m*-xylene is no longer in excess with regard to the other hydrocarbons. In contrast to this the rays of *o*-xylene appear very well marked and this hydrocarbon predominates in the mixture.

The spectrographs of the third fraction show that no *p*-xylene is present, a very little *m*-xylene, and a large proportion of *o*-xylene.

A Study of Various Petroleum Spirits.

The Raman spectra of numerous petroleum spirits of varied origin has been determined in order to ascertain their composition. A summary of the results is given below.

Origin of petroleum	No of fractions	Boiling range, ° C	No of constituents
Sumatra	2	111.5–118	3
Pennsylvania	4	68–127	7
Mar-Borneo	5	80–147	6
Esso-spirits	6	48–126.5	8
Mesopotamian	3	100–200	2
Brandon	15	62–173	15
Venezuelan	11	60–194	15
Cracked spirit	14	28–193	19

As an example of complete analysis the Venezuelan spirit has been taken. It was fractionated into 20 fractions between 60 and 200° C. The higher fractions have not been used because they are strongly fluorescent, giving a luminous blue, which is due to the presence of naphthalene and anthracene derivatives.

1 The fraction of 60° C. gave three rays, the most intense being that of cyclopentane, while the other two corresponded to isohexane. This hydrocarbon has been identified by its other rays.

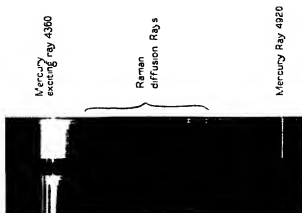

FIG. 2 Raman spectra of a pure hydrocarbon (methylcyclohexane)
 Above exciting mercury rays of 4360
 Below exciting ray 4920 (Liebk.)

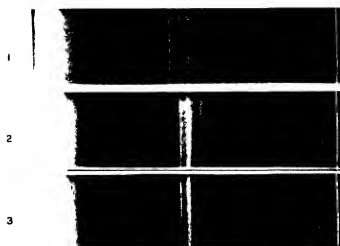

Fig. 3 Raman spectra of mixtures of pure hydrocarbons
 1 Hexane, benzene, cyclohexane (2:2)
 2 Cyclohexane-propylbenzene-orthomethylcyclohexane
 3 Mixture, 1:1 mixture, 2

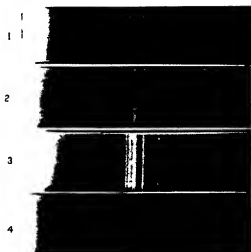

FIG. 4 Research on an impurity in a hydrocarbon
 1 Pure cyclohexadiene
 2 Pure cyclohexane
 3 Impure cyclohexane
 4 Pure cyclohexene + 10% cyclohexadiene

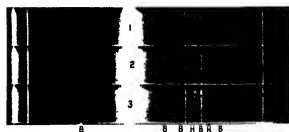

FIG. 5 Raman spectra of fractions obtained from a mixture of hexane-benzene

- 1 Fraction to 70°
- 2 " " 72°
- 3 " " 75°

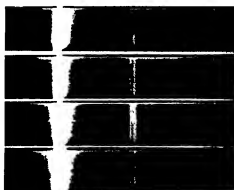

FIG. 6 Raman spectra of fractions obtained from a Borneo spirit

- 1 80-82° Cyclohexane (in quantity)
- 2 96-99° Methylcyclohexane
- 3 115-117° Methylcyclohexane-cycloheptane
- 4 135-136° Saturated hydrocarbons

2 The fraction between 60 and 80° C showed benzene to be the main constituent accompanied by a small portion of isohexane

3 Fraction 80-98° C showed benzene giving a ray at 997 cm^{-1} but this was only present in traces, the greater part of the fraction consisted of cyclohexane

4 Fraction 98-110° C Three rays of toluene were observed, but this was only present in a small quantity Cyclohexane had given place to a large proportion of methylcyclohexane, the rays from which were clearly defined

5 Fraction 110-127° C Toluene the main component

6 Fraction 123-133° C *o*-Dimethylcyclohexane gave very marked rays and was accompanied by traces of ethyl benzene

7 Fraction 133-147° C Ethyl benzene was the main constituent and was accompanied by *p*-xylene together with a very small quantity of methylcycloheptane

8 Fraction 147-158° C Ethyl benzene was present in this fraction in traces, but four intense rays due to methylcyclooctane were observed and hence this hydrocarbon was present in some quantity

9 Fraction 157-176° C Mesitylene was the main constituent of this fraction together with a small quantity of methylcyclooctane

10 Fraction 170-180° C did not show any methylcyclooctane present, but *tert*-butyl benzene or a mixture of the three diethyl benzenes isomers were present since these had similar wave-lengths

The presence of the ray at about $1,548\text{ cm}^{-1}$ suggested the presence of the diethyl benzenes

11 Fraction 180-194° C Fluorescence occurred, and hence no true identification of hydrocarbons was possible, but together with the rays corresponding to naphthalene was found a group of rays corresponding to triethyl benzene

In Fig 6 the Raman spectra of various fractions obtained from Borneo petroleum are given This latter is rich in saturated and cyclohexane type hydrocarbons

In conclusion the preceding examples, it is suggested, show that the Raman spectra can give valuable knowledge regarding the constitution of various petroleum spirits

OPTICAL PROPERTIES

OPTICAL ACTIVITY AND ITS SIGNIFICANCE

By C. E. WOOD, M.Sc., A.L.C., F.C.S., M.Inst.P.T

Lecturer in Chemistry, University of Birmingham, England

The occurrence of optical activity in crude petroleum is world-wide and is a general phenomenon not confined to a particular type of oil as paraffinic, asphaltic, or mixed base crudes. Usually crude oils are dextro-rotatory (cf table by Albrecht and Engler [1] below), a few from Borneo [19, 1907, 43, 1908], Java [9, 1906, 10, 1913], and Argentina [10, 1913] are laevo-rotatory, certain types have a feeble rotatory power only observable with difficulty, and others have been reported as optically inactive [8, 1906] occurring, for example, in the Carpathians [35] (cf analysis of Mahone petroleum [27, 1914])

Origin of oil	Distillation limits °C	Pressure mm	Rotation saccharimeter, 2dm length of column
Argentine	244-302	12	+44.8
Baku (Bibi Ebsat)	230 5-278	12.5-13	+17
Galician (Schodnica)	260-285	15	+22.8
Java	282-286	17.5	+14.3
Pennsylvania	255-297	14	+1.0
Roumanian	250-270	12	+22
Weitz, light	230-276	15	+4.8
„ heavy	265-267	13	+10.8

Examination of the individual fractions of active crudes shows that rotatory power increases with increase of boiling-point from very low values to maxima and then decreases again. These maxima occur in fractions of approximately the same boiling range for different crude oils, and this fact may be quoted as evidence that the optical activity of all petroleum is derived from a common original material. It is stated [4, 1922] that optical activity has not been observed in petroleum fractions boiling under 200° C (atmospheric pressure)

Roumanian crude [34], pressure 15 mm		Czecho-Slovakian crude [44], (Gbeler)	
Fraction °C	Rotation (2dm sugar °)	Fraction °C	Rotation (2dm sugar °)
90-150	Inactive	200-220	+1.1
150-230	Slightly positive	220-240	+1.1
230-240	+0.7	240-250	+0.85
240-260	+1.10	250-260	+0.60
260-270	+3.3		
270-280	+3.8		

Zalozecki and Klarfeld [56, 1907] also found a maximum rotatory power for fractions from 250 to 300° C (12 mm) of Galician crude

The optical activity of petroleum fractions is very resistant to heat and is not destroyed until cracking begins. Rakusn [37] noted that a vaseline oil maintained its rotatory power after heating to boiling-point. Further, the destruction of the activity of a Galician petroleum investigated by Albrecht [15, 1932] only coincided with incipient cracking at 290-320° C. Contrary, however, to the above observation, Engler states that mineral oils wholly or

partially lose their activity when exposed to high temperatures, fractionation should be effected, therefore, under diminished pressure. It is known that heat tends to racemize certain types of optically active hydrocarbons, but distillation of the terpenes under diminished pressure does not affect, appreciably, their rotatory power.

Direct observation of the rotation of polarized light by crudes is attended with difficulty owing to non-transparency both in the natural state and in solution, and to this is due possibly the absence of rotatory dispersion research data in the literature, in this connexion it is interesting to note that the early research workers (1880-97) characterized petroleum oils as inactive [42, 30, 1884, 2]. This opacity is not so marked with fractions obtained by distillation. There is no apparent correlation between rotatory power and locality of origin, and this can be referred to the facts that crudes are, in general, of low dextro-rotatory power not differing appreciably in the same oil-producing areas and complete absence of any peculiarities concerning dispersion.

The nature of the compounds endowing petroleum oils with optical activity has been the object of much investigation. Walden [54, 1906] considered that high boiling-point naphthenic hydrocarbons of vegetable origin were the substances imparting optical activity, and Albrecht attributed the optical activity of Galician petroleum to the presence of one or more hydrocarbons boiling within a narrow high-temperature range. Petroleum is an extremely complex mixture of hydrocarbons of different classes, and optical activity is not necessarily confined to one class, therefore it is to be expected that isolation of an individual optically-active hydrocarbon constituent would be difficult, and, as yet, this has not been accomplished. Even the synthesis and resolution of optically active hydrocarbons presents formidable difficulties, and the optical properties of such have only been determined in a few cases (*d*-methyl-ethyl-*n*-propyl methane $[\alpha]_D^{20} +9.5$ [28, 1904], *d*- α -phenyl- γ -methyl pentane $[\alpha]_D^{20} +17.2$ and *d*- α -phenyl- γ -methyl- Δ^4 -pentane $[\alpha]_D^{20} +43.3$ [22, 1904], *d*- γ -*m*-isopropyl-phenyl- γ -methyl pentane $[\alpha]_D^{20} +15.91$ and *d*- γ -*m*-isopropyl-phenyl- γ -methyl pentane $[\alpha]_D^{20} +41.89$ [23, 1905], *d*-*sec*-butyl benzene [16, 1926], *d*- γ -methyl-*n*-hexane, *d*- γ -methyl-*n*-heptane and *d*- γ -methyl-*n*-octane [25, 1931], 1,3 dimethyl pentamethylene, &c [15, 1932]). Laevo-rotatory aromatic hydrocarbons have been obtained from the sulphonic acids of Roumanian petroleum by Reinhard and Botez[41].

According to Rakusn and Marcusson (cf Bushong and Humphrey [5, 1912]) naphthenic acids are optically active, the activity increasing with increase of boiling-point, but it was shown by Albrecht that these were not the unique source of optical activity, he pointed out that the activity of a Russian cylinder oil was undiminished after treatment with alkali, and the influence of naphthenic soaps on the rotatory power of a lubricant was negligible, for they could only occur to a minute extent in a well-refined lubricant.

Nitrogenous compounds (Hofer [18, 1922]) indicated

the presence of pyridine bases of high molecular weight in different petroleum, and Bailey and his collaborators found that certain quinoline [21, 1930, 47, 1931] and hydroaromatic nitrogen bases [47, 1931] occur to a small extent in oils, but Albrecht observed rotation in a nitrogen-free oil, and, further, that the bases isolated by Schestakow from a Russian kerosene were inactive. Optically active natural sulphur compounds have not been isolated, as far as is known, from petroleum, and it is noteworthy that a 30% removal of sulphur by treatment of a highly active distillate by calcium did not alter the rotation value (Albrecht). Levene and Mikeska [26, 1921] have observed the rotation of certain synthetic mercaptans, reversal of sign of rotation taking place on oxidation to the sulphonic acids.

The early observations of Biot [3, 1835], Tschügäeff [51, 1904], Rakusin [38, 1904], and others of the rotatory power of petroleum in contradistinction to Benedikt [2] led Walden [54, 1906] to postulate an organic (predominantly from plant sources) origin for optically active petroleum. Further, Walden discredited the iron carbide theory on account of the fact that optically active products could only originate from the low temperature degradation of animal and plant substances.

The optical rotatory power of petroleum according to Hofer [18, 1922] is derived from an animal source, which opinion is in agreement with the exhaustive experimental work of Marcusson and accepted in its entirety by Engler, who postulate the presence of a relatively small amount of a strongly active fraction derived from cholesterol (a secondary olefinic alcohol of possible naphthenic structure (*Windsau*), specific for animal life occurring free or combined in fats, gall-stones, &c.) This supposition is closely associated with the generalized Engler theory of formation of petroleum from animal fats. Such glycerides and their pressure distillation products are in general non-active, but cholesterol, which occurs partly free and partly in combination in fats, is active. Cholesterol is laevo-rotatory (certain of its esters are dextro-rotatory [53, 1911]), and when slowly distilled it yields a strongly dextro-rotatory distillate which, when mixed with an inactive petroleum, synthetically compounded, gave an oil the optical activity of which was distributed over the separate fractions in a manner similar to those of an active crude oil, the fraction boiling-point range 240–290°C (14 mm) being particularly active. Rapid distillation (At pressure) of cholesterol yields a low laevo-rotatory distillate which on distilling (reduced pressure) gives first *l*-rotatory, then inactive, and finally *d*-rotatory products, a behaviour analogous to certain types of Java, Borneo, and Argentina petroleum. Although the distillation (260–310°C, 11–17 mm) products of cholesterol show variation of rotatory power, yet they have the same molecular weight [48, 1914]. Steinkopf and his collaborators [45, 1912–20], however, have pointed out that this rotational change cannot be referred to the decomposition of cholesterol, for cholesterol generally occurs only in fractions with boiling-point above 300°C (the digitonin reaction indicating negligible amount of cholesterol in two Java oils), but rather to the products of decomposition under natural geological conditions. Trautenberg [49, 1914] also indicates the invalidity of Marcusson's conclusion that the predominant cause of the optical activity of petroleum lies in the presence of the immediate decomposition products of cholesterol. Possibly [29, 1915] cholesterol when distilled under atmospheric pressure is converted into cholesterylene and other products by loss of water, the former, which contains at least one non-cyclic

double bond, being converted by heat into an optically active cyclic saturated hydrocarbon. These authors [45, 1912–20], who have investigated the thermal catalytic (kieselguhr and quartz) decomposition of cholesterol, infer that the decomposition proceeds with temperature increase through solid laevo- to dextro-cholesterylene which (or a decomposition derived product) is found in the 230–300°C fraction of crudes. But since the optical activity is due to a saturated hydrocarbon or hydrocarbons, hydrogenation or hydrogen displacement must have converted the unsaturated *d*-cholesterylene to saturated *d*-cholestan by the addition of 4 hydrogen atoms. This argument receives support in that the laevo-rotatory character of Java oils remains unchanged after treatment with platinum black, showing that the laevo-compound was saturated, thus unsaturation is not indicative of optical activity. The action of ozone which does not destroy the activity of certain oils points to the presence of a saturated rather than an unsaturated optically active hydrocarbon. In passing, and before mentioning Zelinski's work, it is interesting to note that Trautenberg [49, 1914] found that the products of the dry distillation of cholesterol were unsaturated, for they readily formed formalites, combined with bromine, and rapidly absorbed oxygen.

Certain colour reactions have been quoted as evidence for the cholesterol theory. In early years Rakusin [39, 1906] indicated the presence of optically active cholesterol derivatives in lubricating oils by the Tschügäeff [52, 1900] colour reaction with trichloroacetic acid, but little significance can be attached to this observation, since Charitschkoff [6, 1907] obtained the same colour reaction with a synthetic petroleum free from cholesterol derivatives, Neuberger [31, 1907] arrived at similar conclusions. Still more important is the fact that the optically active oils obtained by Zelinski [57, 1927] through the thermal decomposition of cholesterol in the presence of aluminum chloride did not give the colour reaction. In this connexion it is interesting to note that betulin, a *d*-rotatory phytosterol, gives the colour reactions of cholesterol [40, 1932]. Digitonin gives a precipitate with cholesterol and its hydroxydecomposition products, but since two Javanese petroleum samples failed to give a precipitate with digitonin, Koss [24, 1911] inferred that neither cholesterol nor its decomposition products could be the cause of their activity. This research, however, does not exclude the possibility that hydroxyl-free decomposition products of cholesterol, not reacting with digitonin, might be present.

Colour and digitonin reactions indicate the difficulties of the problem of identification. They are not conclusive evidence and are not specific reactions for generic relationship, even the saturated or unsaturated character of the compound or compounds endowing oils with optical activity which possibly is derived from cholesterol is still in abeyance. Zelinski and his co-workers [58, 1928–31] have shown that the thermal decomposition of cholesterol in the presence of $AlCl_3$ yields a complex mixture of hydrocarbons (paraffins, cyclo-paraffins—cyclohexane derivatives predominating—and only small quantities of aromatics) similar to those occurring in petroleum, and that the optical activity exhibited by the higher boiling fractions (higher illuminating and lubricating oil fractions) disappears almost completely on treatment with sulphuric acid, thus indicating a relationship between optical activity and unsaturation. This relationship was investigated by distilling cholesterylene under both atmospheric and reduced pressure with $AlCl_3$ and fractionation of the

distillate. The fractions obtained, which correspond in physical properties and composition to those derived from cholesterol, were all optically inactive and, as shown by the iodine values, almost wholly saturated, similarly, the catalytic decomposition of cholesterol ether yields inactive fractions of very low iodine number. Cholesterol, however, under the same conditions yields optically active fractions the optical activity of which increases, *pari passu*, with increase of iodine number and boiling-point. Consideration of the molecular weights [48, 1914] of the active products of distillation of cholesterol infers that they are unsaturated. Using kieselguhr in place of $AlCl_3$, Steinkopf has obtained products from cholesterol similar to those described by Zelinsku and infers that under natural conditions this compound forms possibly first a laevo- and then a dextro-rotatory cholesterylene which give rise to products of variable hydrogen content. Both Steinkopf's and Zelinsku's researches indicate the general correctness, but are not absolute proof of Engler's view [46, 1927].

The tentative bicyclic structure for cholesterol contains a number of asymmetric carbon atoms besides the possibility of other dissymmetric groups, and rotational change on distillation may be due to internal or external (or both) compensation or racemization of the product. Traubenberg [49, 1914], considering the results of Engler's fundamental researches and his own into the optical activity of cholesterol distillates, infers the high probability of cholesterol being the chief foundation of the optical activity of petroleum.

Engler and Marcusson [11, 1913], Zaloznecki and Klarfeld [56, 1907] consider that phytosterol and resin acids (resins) may be the active constituents in the plant origin of petroleum. All phytosterols (certain are dextro-, others laevo-rotatory), regardless of their large number, are genetically related to animal cholesterol and are the vegetable analogues of cholesterol. On account of this close relationship, investigation of the physical and chemical properties of distillation products of phytosterol and of abietic acid (the principal constituent of ordinary commercial rosin) are of interest. Both Traubenberg [50, 1916, 13, 1932] and Rakusin [40, 1932], on distilling *d*-rotatory betulin, a phytosterol occurring in birch bark with $AlCl_3$, obtained a *d*-rotatory unsaturated (iodine number, 45) low boiling-point (up to 150° C) fraction, Rakusin [40, 1932], investigating the action of $AlCl_3$ on abietic acid (prepared from colophony), obtained optically active unsaturated condensates which on repeated treatment with $AlCl_3$ gave almost-saturated inactive oils.

Zelinsku and Semganowski [59, 1929], starting from optically inactive resin acids (prepared from white coniferous resin), obtained various *d*-rotatory distillation fractions, these preliminary products were optically active, their activity being related to their degree of unsaturation, the combined optically active primary products on further treatment with $AlCl_3$ were converted into an optically inactive, practically saturated condensate with an odour

strongly resembling petroleum. These important results and the fact that Ciamician [7, 1878], using zinc dust, obtained hydrocarbons similar to those in petroleum makes it probable that plant resins play a material part in the formation of petroleum.

Both Walden (55, 1900, cf 33, 1927) and Mabery [27, 1914] did not support the cholesterol but inclined rather to the vegetation hypothesis (Mabery regarded the origin of Californian petroleum as due to bacterial action on the decayed vegetation products). Optical activity is a very typical characteristic of vegetable products (sources of optically active compounds are chiefly of vegetable origin), and the activity and odour of certain oils may be produced, in part, by terpene containing essential oils. Freund [12, 1932] has succeeded in obtaining hydrocarbons resembling petroleum from French turpentine oil (*p*-pinene principal constituent). *l*-Rotatory turpentine with $AlCl_3$ gives rise to dextro-rotatory polymerization products, fractional distillation of the liquid polymerization products gave distillates which exhibited a displacement of the rotation from dextro to laevo and then to dextro again with increase of boiling-point—a property of Java petroleum. The petroleum-like hydrocarbons obtained by this catalytic polymerization on further heating with $AlCl_3$ gave rise to low-boiling *d*-rotatory and then to high-boiling *d*-rotatory fractions precisely similar to those fractions of the same boiling-point range found in Java, Borneo, and Argentina oils. Freund, after reviewing the literature, considers that terpenes may be an essential factor of the optical activity of petroleum, further, the dextro is the more stable enantiomorph.

Among the more important properties of petroleum, optical activity and nitrogen content would appear to indicate an organic origin, but Pynala [36, 1922], owing to the fact that the optical activity of petroleum is due to the presence of only a small percentage of optically active compounds, considers that it is not possible to conclude an organic origin for the whole of petroleum, he postulates an inorganic origin, and the optically active compounds present are merely accessory components taken up by petroleum migrating through strata containing plant remains. The nitrogen content of petroleum, asphalt, and natural gas also affect this inorganic hypothesis, inasmuch as amino-acids [32, 1905], the fundamental units of proteins, may yield by decarboxylation and demitamination non-acidic nitrogen compounds (pyridine bases, &c.) as well as optically active non-nitrogenous products.

The study of the unsaponifiable constituents of fish-liver oils [14, 1920] may be associated also with this problem. Although squalene [17, 1926-33, 20, 1930], the hydrocarbon isolated from various shark livers, and in which it occurs to the extent of 30% approximately, is inactive, yet it is associated with an optically active alcohol, viz. butyl alcohol $[\alpha]_{D}^{25} + 2.6^\circ$ (c 0.95) [17, 1926-33], the acetate of which is laevo-rotatory $[\alpha]_{D}^{25} - 8.5^\circ$ (c 2.65) in chloroform.

REFERENCES

- 1 ALBRECHT and ENGLER. Dissertation. Engler, *Peir Z* 2, nos 20-3.
- 2 BRENDEKT. *Analyse d Fette und Wachsarten*, 3 Aufl 206, also 3 Aufl 225.
- 3 BROT. *Mém de l'acad de Science*, 13, 139 (1835).
- 4 BROOKS, B T. *The Non-benzenoid Hydrocarbons*, p 566 (1922).
- 5 BURBONO, F W and HUMPHREY, I W. *8th Int Cong Appl Chem* 6, 57 (1912).
- 6 CZARITSCHKOFF, K W. *Chem Rev* p 120 (1907).
- 7 CIAMICIAN, G. *Ber* 11, 269 (1878).
- 8 COATES, C E. *J A C S* 28, 384 (1906).
- 9 ENGLER, C. *Die neueren Untere d Erdöl*, 187 (1906).
- 10 ——. *Das Erdöl* 1, chap 13, p 173 (1913).
- 11 ——. *Die Chemie und Physik des Erdöl*, 212, 754 (Leipzig, 1913).
- 12 FREUND, M. *Peir Z* 28 (37), 1 (1932).
- 13 FURST, K. *Allgem Chem-Techn-Zig* 50, no. 13, 89, (1932).
- 14 GRUN, A and WIRTH, T H. *Ber* 53, u 1301 (1920).

- 15 GURWITICH, L and MOORE, H *The Scientific Principles of Petroleum Technology*, 218 (Chapman & Hall, 1932)
- 16 HARRISON, P, KENTON, J, and SHEPHERD, J *J C S* 658 (1926)
- 17 HEILBRON, I M, KAMM, E D, and OWENS, W H *J C S* 1630 (1926), 883 (1929), &c
DAVIES, W H, HEILBRON, I M, and JONES, W E *Ibid* 165 (1933)
- 18 HOFER-HEMHALT *Das Erdöl und seine Verwandten* (Braunschweig, 1922)
- 19 JONES, H O and WOOTON, H A *J C S* 91, 1146 (1907)
- 20 KARRER, P, HELFENSTEIN, A, WEHRLI, H, and WEITSTEIN, A *Helv Chim Acta*, 13, 1084 (1930)
- 21 KING, W A and BAILEY, J R *J A C S* 52, 1245 (1930)
- 22 KLAGES, A and SAUTTER, R *Ber* 37, 649 (1904)
- 23 ——— *Ber* 38, 2312 (1905)
- 24 KORS *J Russ Phys-chem Ges* 697 (1911), cf Stenckopf, *Chemkerzeitung*, 72 (1912)
- 25 LEVINE, P A and MARKER, R E *J Biol Chem* 91, 761 (1931)
- 26 LEVINE, P A and MIKESKA, L A *J Biol Chem* 65, 515 (1921)
- 27 MAREY, C F *Ind Eng Chem* 6, 101 (1914)
- 28 MARCKWALD, W *Ber* 37, 1046 (1904)
- 29 MARCUSON, J *Chem Ztg* 38, 39 (1915)
- 30 MARKOWNIKOFF *J Russ Phys Chem* 15, 237 (1884)
- 31 NEUBERG, C *Biochem Z* 7, 205 (1907)
- 32 ——— *Z f Angew Chem* 18, 1616 (1905)
- 33 POTONÍ, R *Petr Z* 23, 395 (1927)
- 34 PREDESCU, C *Bull Soc Sci acad Roumania*, 6, 181 (1919-20)
- 35 PYHALA Ein Beitrag zur Genesis des Erdöls *Petroleum*, 19 (6), 536, footnote 27
- 36 ——— *Petr Z* 23 (25), 1069, &c (1922)
- 37 RAKUSIN, M A *Petr Z* 3, 436
- 38 ——— *J Russ Phys chem*, Gv 36, 456 (1904), *Chem Ztg* 505 (1904)
- 39 ——— *Chem Ztg* 1041 (1906)
- 40 RAKUSIN, M A *Petr Z* 28 (3), 9 (1932)
- 41 REINHARD and BOTZEE *Rev Petr* 1, no 1
- 42 REMONT *Bull Soc Chim* 33, 401, 525
- 43 SCHERLE *Diss Basel*, 55 (1908)
- 44 SCHULZ, F *Petr Z* 18 (9), 322 (1922)
- 45 STEINKOPF, W, KORS, A K, and LIEBMAN, S *Chem Z* 36, 653 (1912)
- STEINKOPF, W, WINTERITZ, H, ROEDERER, W and WOLYNSKI, A *J Prakt Chem* 100, 65 (1919)
- STFINKOFF, W and BEISDORF, F *J Prakt Chem* 101, 75 (1920)
- STEINKOPF, W and WINTERITZ, H *Chem Ztg* 28, 613 (1914)
- 46 STEINKOPF, W *Ber* 60b, 2609 (1927)
- 47 THOMPSON, W C and BAILEY, J R *J A C S* 53, 1002 (1931)
- 48 TRAUBNERRO, I K *Chem Ztg* 38, 950 (1914)
- 49 ——— *J Russ Phys Chem Soc* 46, 1043 (1914)
- 50 ——— *J Russ Phys Chem Soc Proceed* 48, 707 (1916)
- 51 Tschugaeff *J Russ Phys Chem Soc* 36, 453 (1904)
- 52 ——— Sur certaines réactions de la cholestérine *Arch russes de Pathol et Méd clinique et de Bactériologie*, publi sous la direction de M le Prof V Podwysotsky (1900)
- 53 VORLANDER, D and HÜTH, M E *Z Physik Chem* 75, 641 (1911)
- 54 WALDEN, P *Chem Ztg* 30, 391, 1155, 1167 (1906)
- 55 ——— *Funfundzwanzig Jahre Stereochemische Forschung Naturw Rundschau*, Nr 16, S 198 (1900)
- 56 ZALCZICHI, R, and KLARFELD, H *Chem Ztg* 31, 1155, 1170 (1907)
- 57 ZELINSKII, N D *Ber* 60b, 1793 (1927)
- 58 ZELINSKII, N D, and KOSLOV *Ber* 64b, 2130 (1931)
- ZELINSKII, N D, and SEMIGANOWSKI, N N *Ber* 62b, 2199 (1929)
- ZELINSKII, N D, and LAVROSKII, K P *Ber* 61b, 1291 (1928)
- 59 ZELINSKII, N D, and SEMIGANOWSKI, N N *Ber* 62b, 2202 (1929)

THE APPLICATION OF MAGNETIC OPTICAL PROPERTIES IN THE ANALYSIS OF HYDROCARBON MIXTURES

By Dr. M. SCHERER

University of Strasbourg

MEASUREMENTS of optical rotation have been applied with success in the analysis of mixtures of naturally occurring optically active substances, such as the sugars and vegetable sprits. This application has been facilitated by the use of Biot's additive law, resulting from the specific rotation of mixtures of several active liquids, the amount of rotation being a linear function of the quantities of the various constituents present.

It was thought that an analogous method could be applied to hydrocarbon mixtures if a similar optical property could be utilized. The rotation of polarized light can be caused in transparent substances by placing them in a magnetic field of force. This phenomenon is Faraday's magnetic rotatory polarization effect. It is produced when a number of luminous polarized rectilinear rays pass through a transparent body in the direction of the lines of magnetic force. For a distance of l cm, and a field intensity of H gauss, a value $\alpha = \rho H l$ is obtained. The constant of proportionality between the strength of the magnetic field and the rotation of the plane of polarization for a given wave-length or Verdet's constant, follows an identical law to that of

Biot $\frac{\rho}{d} = \sum [\frac{\rho_i}{d_i}] x_i$. The constant ρ_i is the characteristic of the constituent of amount x_i and of density d_i , and the specific rotation of the mixture is ρ/d . Deviations from the additive law, which are obtained for some mixtures, do not occur in the case of hydrocarbons. It may be asked whether by using different wave-lengths characteristic equations can be obtained, and hence measurements of quantities of unknown substances made. A study of this point is given in this article.

Verdet's constant is of the order of 0.01 minute-gauss/cm for radiations in the visual region.

This effect is therefore easily measured in the magnetic field of a solenoid or electromagnet, the method only being used with small quantities of the substance for analysis.

The optical equipment used for these experiments consists of a source of light from a mercury vapour lamp, the rays from which are separated by a monochromatic filter fitted with a Pellin-Broca prism, and from this through a lens to give parallel rays. These rays are then polarized, by passing through a Nicol prism, before entering the magnetic field of an electromagnet. Convenient diaphragms prevent reflection of the light by the pole pieces of the magnet. The rays are then analysed using an analyser fitted with a Lippich prism a sighting tube mounted on the end stop of the prism, together with a Glaesbrook analyser and a circular disk graduated to 1/100 of a degree, completes the outfit.

The electromagnet used is of the Weiss type, equipped with pole pieces drilled with 8-mm holes. The air gap is about 50 mm. Measurements are made by reversing the direction of the current and counting the rotation of the mirror shutters on the polarimeter tray.

These measurements are relative, distilled water being used as a standard, and measuring the rotation under the same conditions as for the hydrocarbons. The following tables give values of Verdet's constant ρ/ρ_{H_2O} for radiations of wave-length $\lambda = 546m\mu$, with $\rho_{H_2O} = 0.0153$ at 20° C. The ratio ρ_{270}/ρ_{430} of the rotation caused by the hydrocarbons for the yellow and violet rays fixes the amount of dispersion due to the Faraday effect. In most cases this dispersion was not determined, it being less than 1/200 in relative value.

TABLE I
Normal Saturated

Hydrocarbon Temperature, ° C	C ₂ H ₁₆ 15	C ₃ H ₁₈ 15.5	C ₄ H ₂₀ 22	C ₅ H ₂₂ 20.5	C ₆ H ₂₄ 20.8	C ₇ H ₂₆ 20.5	C ₈ H ₂₈ 21.5	C ₉ H ₃₀ 21	C ₁₀ H ₃₂ 21
$\frac{\rho}{\rho_{H_2O}}$	0.93 ₂	0.96	0.96 ₂	0.97 ₂	0.99 ₂	1.00	1.01	1.02 ₂	1.03 ₂

TABLE II
Normal Ethylenic Type

Hydrocarbon Temperature, ° C	C ₂ H ₁₆ 15.5	C ₂ H ₁₈ 21	C ₂ H ₂₀ 21	C ₂ H ₂₂ 21	C ₂ H ₂₄ 21	C ₂ H ₂₆ 21
$\frac{\rho}{\rho_{H_2O}}$	1.08	1.10 ₂	1.10 ₂	1.10 ₂	1.10 ₂	1.10

TABLE III
Normal Acetylene Type

Hydrocarbon Temperature, ° C	C ₂ H ₂ 20	C ₂ H ₄ 17
$\frac{\rho}{\rho_{H_2O}}$	1.14 ₂	1.14 ₂

TABLE IV
Benzene Type

Hydrocarbon Temperature, °C	Toluene 15	Ethylbenzene 22	Propylbenzene 22	Butylbenzene 20
$\frac{\rho}{\beta_{Bo}}$	2.08	2.00 _g	1.89 _g	1.81 _g
Hydrocarbon Temperature, °C	Ethylbenzene 21	Diethylbenzene 17	Triethylbenzene 20	Tetraethylbenzene 17
$\frac{\rho}{\beta_{Bo}}$	1.94	1.87	1.75	1.74
Hydrocarbon Temperature, °C	Diphenylpentane 17.5	Diphenylhexane 20	Diphenyloctane 20	
$\frac{\rho}{\beta_{Bo}}$	2.20	2.10 _g	2.00	

TABLE V
Naphthalene Type

Hydrocarbon Temperature, °C	Naphthalene 83.5	Decalin 18.5	α -Methylnaphthalene 18	β -Methylnaphthalene 34
$\frac{\rho}{\beta_{Bo}}$	3.45	1.09 _g	3.59	3.32

The Verdet constant for water being taken as unity, the specific rotations of various hydrocarbons are as follows

(a) Normal saturated hydrocarbons	C ₇ to C ₁₈	1.42 to 1.34
(b) Ethylene type hydrocarbons	C ₇ to C ₁₈	1.54 to 1.41
(c) Benzene " "	C ₆ to butylbenzene	2.50 to 2.11
(d) Acetylene ..	C ₂ to C ₈	1.57 to 1.54
(e) Cyclohexane type hydrocarbons		1.21
(f) Cyclohexene ..		1.35
(g) Naphthalene ..		3.90 to 3.65

These figures show that the magnetic rotation method separates with difficulty the series (a) and (f), but the other series are easily differentiated by taking the mean value of the constant for each. For example, it is comparatively easy in a field of 22,000 gauss, and with 3 cc of liquid, to determine 4% of cyclohexane, with an accuracy of 0.5%, in the binary mixture benzene, cyclohexane. The following figures indicate the information given by the dispersion. The ratio ρ_{270}/ρ_{135} is given for the following series

(a)	(b)	(c)	(d)	(f)
1.84	1.87	2.00	1.84	1.90

The normal hydrocarbons of the paraffinic and cyclohexane series have similar dispersion values, whereas the other hydrocarbons show measurable differences, which distinguish them.

Certain structures are affected more by magnetic rotation than by refraction, in such a way that tautomeric changes can be shown to exist. However, in the case of hydrocarbons certain properties, such as isomerism in the same series, do not give appreciable differences. Another property, viz the magnetic optical property, is more sensitive in this respect and completes the information given by the magnetic rotation. This property is that of magnetic birefringence, or the Cotton-Mouton effect.

Cotton-Mouton Effect.

Certain substances when placed in a magnetic field of force adopt the optical properties of a uniaxial crystal, of which the neutral lines are (1) parallel and (2) perpendicular to the lines of force. Luminous rays polarized rectilinearly

are propagated normally to the lines of force, thus a study can be made of the birefringency of the medium. Given that n_x and n_y are the principal indices of refraction for the luminous vibrations parallel and perpendicular to the lines of force and a distance l , then the medium sets up between the vibrations an optical motion, $l(n_x - n_y)$ or a difference of phase $\rho = \frac{2\pi}{\lambda}(n_x - n_y)$. Cotton and Mouton state that $\rho = 2\pi CH^2$, the constant C depending on the substance, the wave-length used, and the temperature. This constant is similar to that of Verdet for hydrocarbons, but is very much smaller, being of the order 10^{-18} for nitrobenzene. Only powerful electromagnets similar to that at Bellevue can be used for measurements 500-1,000 times smaller.

With this apparatus an active substance such as nitrobenzene can give a phase difference ρ of about 55° for the mercury green ray. The method consists, in principle, of passing rectilinear vibrations through the liquid, such that the plane of polarization makes an angle of 45° with the lines of force of the field. On emerging it is changed to a luminous elliptical vibration, of which the ratio of the axes, or ellipticity, has a value $\tan \beta$ such that $\beta = \rho/2$, and β is said to be the angle of ellipticity, and is the angle measured by the quarter-wave method. A quarter-wave plate is interposed, of which the neutral lines coincide with the direction of the incident vibration, and thus rectilinear polarization is again obtained. The direction of this new rectilinear vibration forms the angle β with that of the incident vibration. The rotation of the plane of polarized light is measured. The following table gives the values $(C/d)10^{18}$ (d = density)

Saturated normal hydrocarbons	C ₇ to C ₁₈	-0.007 to -0.036
Ethylene type hydrocarbons	C ₇ to C ₁₈	-0.008 to -0.014
Acetylene ..	C ₂ to C ₈	-0.044 to -0.074
Cyclohexane type hydrocarbons		-0.010 to -0.015
Cyclohexene ..		0.015
Cyclohexadiene type hydrocarbons		0.12
Normal benzene ..		0.62 to 0.42
Naphthalene ..		2.4
Phenanthrene ..		5.8

These figures classify the benzenoid hydrocarbons in one section of which the Cotton-Mouton constant is very high, and the saturated aliphatic and cyclohexane type of hydrocarbons into another section of which the constant is small and negative. The ethylene and cyclohexene type of hydrocarbons are in the transition stage between the two sections. It is seen, therefore, that on samples of benzene-hexane and benzene-cyclohexane, it is possible to measure 0.5% of benzene in a volume of 20 c.c. of the mixture, using a field strength of 43,000 gauss.

The literature has been cited for detailed tables relative to the various series. Only certain isomeric cases have been given, i.e. those which show the value of this method of analysis.

Xylenes

$C_8H_{10}-(CH_3)_2$	r^*	b_s^*
Ortho	14	31.6
Meta	16	28.8
Para	20	31

Trisubstituted Derivatives

$C_8H_7(CH_3)_3$	r^*	b_s^*
Pseudocumene	17	31.8
Mesitylene	16	25.8

Methylcyclohexanes

$C_7H_{12}(CH_3)_2$	r^*	b_s^*
Ortho	15	-0.3
Meta	15	-0.4
Para	15	-0.6

* $b_s = b/d$, b being the ratio (multiplied by 100) birefringency of the hydrocarbon to that of nitrobenzene and d is the density.

Petrols.

The following samples are fractions distilled up to 250° C, refined with 1% sulphuric acid and with alkali and water, and then redistilled to 250° C, a 'Doctor test' is negative. Measurements of the magnetic rotation, the density, and refractive index gives the following results.

Petrol	ρ g/cc	n_{D20} g/cc	n_{D20} g/cc	d_{20}^{20}	n_D^{20}	$n_{D20} - n_{D20}^*$ g/cc
Texasco, W						
Columbia	1.27	0.88	1.65	0.853	1.466	126 1 ⁺
Pechelbronn	1.13	0.88	1.65	0.780	1.436	120 1 ⁺
Mid-Continent	1.32	0.88	1.65	0.775	1.432	150 1 ⁺
Columbia	1.29	0.88	1.64	0.859	1.469	130 1 ⁺
Iraq	1.37	0.88	1.65	0.767	1.430	150 1 ⁺
Moreni oil	1.50	0.88	1.69	0.839	1.468	140 1 ⁺
Borislav	1.07	0.88	1.66			
Bitkow 132	1.08	0.88	1.66			
Bitkow 129	1.02	0.88	1.65			

These samples have very different Verdet constants, the differences being more marked than those existing between the refractive dispersion. A comparison of the indices n_D and of the ratio ρ/n_{D20} shows that the variations are of the same order, except in the case of the Moreni oil, in which case the magnetic rotation is very much higher. This corresponds to the fact that this oil contains a greater

percentage of benzenoid and naphthenic hydrocarbons. The figures for the magnetic birefringence are given below.

Origin	$r^* C$	M bir λ_{515}	ρ_{20} ρ_{20}	ρ_{20} ρ_{20}	C d 10 ¹⁴
Texasco, W Columbia	15	0.53	0.90	1.466	6.25
Pechelbronn	16.5	0.43	0.96	1.43	5.53
Mid-Continent	16	0.42		1.40	
Columbia	16.7	0.70	0.96	1.38	8.15
Iraq	15	0.63	0.90	1.26	8.21
Moreni oil	16	2.27	0.93	1.37	27.00
Bitkow 129	19	0.56	0.94	1.46	
Bitkow 132	19	0.85	0.93	1.3	
Borislav W II	19	0.90	0.89		
Nitrobenzene	18.1	25.05			

In spite of the smallness of the birefringence of these liquids, it is seen that marked differences occur between them.

On calculation of the specific birefringence and comparing the values obtained, it is seen that the Moreni oil is very rich in aromatic hydrocarbons and that the oils from Bitkow 132 and Borislav are high, but those from Pechelbronn and Mid-Continent are low. In order to study the saturated hydrocarbon content of petrols, aromatic and unsaturated aliphatic hydrocarbons are first eliminated by nitration. It is important to remove completely all nitrogenous bodies, since these are extremely active from the point of view of magnetic birefringence. Repeated sulphuric acid washes were made, and the clear oil obtained was redistilled prior to measurement of the magnetic birefringence, which was negative in each case.

Origin	$r^* C$	M bir λ_{515}
Pechelbronn	23	-0.10,
Mid-Continent	23	-0.11,
Iraq	23	-0.11,
Peru	23	-0.06
Nitrobenzene	22	24.24

It should be noted that the saturated hydrocarbons from Pechelbronn, Mid-Continent, and Iraq have equal values for the birefringence these latter being composed of higher saturated bodies or cyclic hydrocarbons.

Mineral Oil.

Complete fractionation of a red mineral oil of density $d_{20} = 0.911$ distilled in the cathode ray, gave the following values for the magnetic birefringence and natural rotation.

Fraction	Boiling range, °C	d_{20}^{20}	n_{20}	M bir λ_{515}	$[\alpha]_{20}^{20}$
I	100-168	0.903	1.498	0.90	0.52
II	165-179	0.907	1.498		
III	179-187	0.909	1.499		
IV	187-196	0.912	1.499	0.65	1.51
V	196-206	0.913	1.499	0.62	1.73
VI	206-213	0.914	1.500	0.49	2.08
VII	213-219	0.913	1.499		
VIII	219-226	0.910	1.498	0.55	1.95
IX	226-234	0.904	1.497	very viscous and	
X	234-240	0.905	1.497	fluorescent	
Nitrobenzene				6.78	

There is therefore a minimum value for the magnetic birefringence, and a maximum activity at fraction VI. Fraction I was separated into ten equal fractions, and the figures obtained are given below. This table shows that large variations can occur in the birefringence of two

close fractions such as I₁ and I₂. This difference aids in the identification of the fractions. The information given by the variations of the density and of the refractive index being much less precise.

Fraction	Boiling range, °C	d_{20}	n_D	M_{br} λ_{478}	$[\alpha]_{478}$
I ₁	100-130	0.886	1.488	0.83	20
I ₂	130-139	0.895	1.493	0.96	
I ₃	139-149	0.901	1.496		0.33
I ₄	149-155	0.903	1.497		
I ₅	155-157	0.904	1.498		
I ₆	157-158.5	0.905	1.498		
I ₇	158.5-159	0.905	1.498		
I ₈	159-161	0.906	1.498	0.84	
I ₉	161-164	0.906	1.498		
I ₁₀	164	0.911	1.499		
Nitro- benzene				6.78	

SELECTED BIBLIOGRAPHY

LOWRY, Prof. T. MARTIN *Optical Rotatory Powers* (Longmans, Green & Co., 1935)

SCHERRER *On the Magnetic Optical Properties of Liquids* (Applica-

tion to the Analysis of Hydrocarbons. Publications scientifiques et techniques du Ministère de l'Air no. 50 (Gauthiers-Villars, Paris.)

THERMAL, CRITICAL AND P.-V.-T. DATA AND THEIR MEASUREMENT

APPARATUS AND METHODS FOR DETERMINING THERMAL PROPERTIES OF PETROLEUM PRODUCTS

By R. S. JESSUP, M A

Associate Physicist, National Bureau of Standards, U S Department of Commerce

I. Introduction

The engineer who designs equipment for processes involving heat finds that a knowledge of the thermal properties of fluids is of fundamental importance. Tables of the properties of steam and ammonia have been available to him for about 50 years, but for petroleum products the data are meagre and in many cases unreliable. This condition may exist because the task of obtaining necessary data for the host of different products appears too formidable. It has been shown, however, that thermal properties may be correlated with certain commonly measured properties such as density, viscosity, distillation characteristics, &c.

It appears very probable, therefore, that, if sufficient accurate data were available on a relatively small number of petroleum products, it would be possible to compile practical tables giving the thermal properties of these products as functions of pressure, temperature, and one or more of the commonly measured properties mentioned above, and that the data in these tables would be reasonably representative of the properties of all petroleum products.

This article reviews briefly some of the apparatus and methods which are appropriate for measurements of thermal properties of petroleum products. On account of the limitations of space the descriptions will necessarily be very brief, and the reader is referred to the original publications for details.

II. Energy Units

The energy unit used at present in practically all precise calorimetric measurements is the international joule, or some unit defined in terms of the international joule. Such a unit is preferable for a number of reasons to a unit defined in terms of the properties of water [35, 1930, 46, 1935]. In much recent thermochemical work, for example, the energy unit used is a calorie defined by the relation [41, 1934]

$$1 \text{ gram calorie} = 4.1833 \text{ int joules}$$

The B Th U may be defined in terms of the calorie by the relation

$$1 \text{ B Th U} = 252.0 \text{ gram calories,}$$

where the factor 252.0 is calculated from the relative sizes of the pound and gram, and of the Fahrenheit and Centigrade degrees. The units so defined are independent of the properties of water, but are equal to the corresponding units defined in terms of the specific heat of water at 15° C (59° F.) within the accuracy with which the specific heat of water at that temperature is known.

III. Stirred Liquid Calorimeters

The stirred liquid calorimeter has been developed as an instrument of high precision principally by Jaeger and von

Steinwehr [25, 1903, 26, 1906, 27, 1928], T W Richards and his co-workers [42, 1905, 43, 1910], Dickinson [12, 1914], and White [57, 1928]. Fig 1 is a schematic diagram of a calorimeter of this type with a constant-volume bomb for measurements of heats of combustion. Fig 2 illustrates a calorimeter made from a vacuum bottle, and arranged for measurements of specific heats of liquids.

Precision in calorimetric measurements depends mainly on two things, namely, accurate temperature measurements, and accurate knowledge and control of the conditions which determine the transfer of heat between the calorimeter and its surroundings.

Temperature Measurements.

Temperature measurements in some cases are made by means of mercurial thermometers. Such thermometers are subject to errors due to hysteresis, and to sticking of the mercury meniscus. Errors due to sticking of the meniscus may be reduced by gently tapping the thermometer while reading it, or by means of vibrations produced by a small electric buzzer attached to the thermometer.

A calibrated Beckmann thermometer graduated to 0.01° C and read to 0.001° can be used to measure a 2° temperature rise with a precision of about 0.1%. Somewhat higher precision can be attained by increasing the temperature rise, for example, to 5° C.

To attain a precision better than 0.1% in the measurement of small temperature intervals it is necessary to use either an electrical resistance thermometer or a thermel (thermoelectric thermometer). Calorimetric electrical resistance thermometers have been described by Dickinson and Mueller [13, 1913] and by Sligh [49, 1922]. Bridges for use with resistance thermometers have been described by Mueller [36, 1916] and by Smith [50, 1912]. Thermels and potentiometers have been described by White [55, 1914, 56, 1914, 58, 1933]. Many of the instruments described in these publications can now be obtained from instrument manufacturers.

Accuracy in temperature measurement requires, in addition to accurate thermometry, adequate stirring of the calorimetric liquid so as to give a uniform and therefore definitely measurable temperature. It has been shown [37, 1914] that a screw propeller mounted in a tube is considerably more effective in equalizing the temperature than the ring stirrer used in many calorimeters, at least where there is a large obstruction such as a combustion bomb in the calorimeter.

The speed of stirring should be sufficient to give adequate equalization of temperature, but not so great as to produce excessive quantities of heat. According to White [57, 1928], for a precision of 0.1% the heat of stirring should not cause the temperature of the calorimeter to rise more than

0.001° C per minute. Correction for heat of stirring is usually based on the assumption that the rate of production of heat is constant. Hence the speed of the stirrer should be kept constant by means of a governor, or by driving it by means of a constant-speed motor. The design of stirrers has been discussed by White [57, 1928]

radiation. Jackets immersed in stirred water baths and surrounding the sides and bottoms of calorimeters are quite common, but the difficulty of bringing the jacket over the top of the calorimeter is usually avoided. Dickinson [12, 1914] and White [57, 1928] have described jacket covers through which the jacket water circulates. The jacket of

Richards's "submarine" calorimeter [43, 1910] was provided with a water-tight cover, and the entire jacket was immersed in a stirred water bath. According to White [57, 1928] the simple jacket cover illustrated in Figs 1 and 2 is almost as good as the more elaborate ones. This cover consists of two pieces of sheet copper separated by an air space, and bent down at the edges so as to dip into the jacket water. The upper sheet is protected from the effect of the room by a layer of insulating material.

The corrections for heat of stirring and for heat transfer between calorimeter and jacket are usually calculated from observations of the rate of change of the calorimeter temperature in two rating periods, one before and one after the main temperature rise, when no other source of temperature change except heat transfer and heat of stirring is present. The calculation is based on the assumption that the rate of production of heat by stirring is constant, and that the rate of heat transfer is proportional to the temperature difference between calorimeter and jacket (Newton's law of cooling). The latter assumption is a sufficiently close approximation, at least for temperature differences of not more than 5 or 6° C, for heat transfer resulting from the combined effects of conduction, convection, and radiation, provided that the calorimeter is completely enclosed by the jacket, and that calorimeter and jacket are separated by an air space about 1 cm. wide. Methods of calculating the corrections for heat transfer and heat of stirring have been given by a number of writers [12, 1914, 27, 1928, 57, 1928]

Heat transfer by evaporation does not follow Newton's law, and is likely to be irregular. Therefore

evaporation should be prevented as far as possible. Evaporation from the calorimeter can be greatly reduced by a closely fitting cover, which should be made of metal and should be in contact with the calorimetric liquid. The calorimeter cover shown in Fig 1 consists of a flat circular disk of sheet copper with vertical sides, and with collars around the necessary holes for thermometer, heat leads, &c. If the calorimetric liquid is water, two or three drops of oil in each of these holes help to reduce evaporation still further. A cover which can be more quickly put in place after dropping some object into the calorimeter, as in the

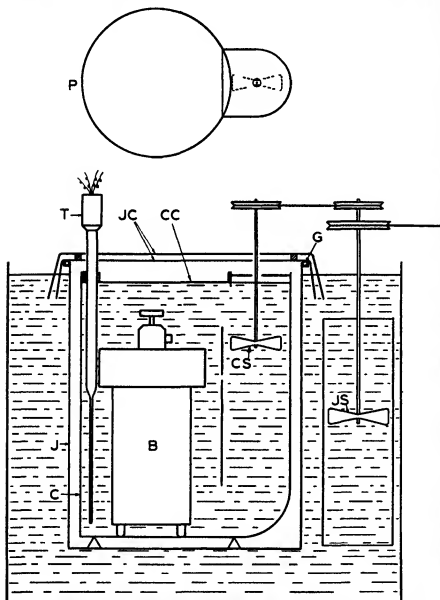

FIG 1 Stirred liquid calorimeter arranged for measurements of heats of combustion. P, plan of calorimeter, T, resistance thermometer, J, jacket, C, calorimeter, B, bomb, JC, jacket cover, CC, calorimeter cover, CS, calorimeter stirrer, JS, jacket stirrer, G, gasket

Heat Transfer between Calorimeter and Surroundings.

Since there are no perfect heat insulators there will be a loss or gain of heat by the calorimeter whenever its temperature differs from that of the surroundings. This loss or gain of heat can take place by conduction, convection, radiation, and evaporation or condensation. In order that the transfer of heat shall be determinate it is desirable that the calorimeter be enclosed by a jacket, the temperature of which is measured or controlled. Calorimeters and jackets are usually nickel-plated to reduce heat transfer by

method of mixtures, has been described by White [54, 1910] Methods of sealing stirrer shafts so as to reduce evaporation have been described by White [57, 1928] and by Barry [5, 1922] Condensation on the calorimeter of water which evaporates from the jacket can be reduced by making the jacket cover tight by means of a gasket as illustrated in Fig 1

In cases where it is not feasible to prevent evaporation from the calorimeter by means of the devices mentioned above, it can be reduced by proper procedure Thus, if the jacket is closed so tightly that no water vapour can enter the space between jacket and calorimeter from outside, and if the temperature of the calorimeter is kept below that of the jacket, evaporation from the calorimeter will be only that required to saturate the space between calorimeter and jacket If the calorimeter temperature should rise above that of the jacket, and if evaporation from the calorimeter is not prevented, there will be a continuous transfer of heat by evaporation from the calorimeter and condensation on the jacket wall, and Newton's law of cooling will no longer hold

Richards [42, 1905] avoided corrections for heat transfer by means of the adiabatic method, which consists in keeping the jacket temperature always equal to that of the calorimeter A correction for heat of stirring is still necessary with this method As pointed out by White [57, 1928] and Dickinson [12, 1914], although the adiabatic method reduces the correction for heat transfer, it does not reduce errors due to heat transfer in short-time experiments, and in some cases makes them worse on account of the difficulty of keeping the jacket temperature always equal to the calorimeter temperature, which may be changing very rapidly during part of an experiment The adiabatic method, however, is essential in experiments which extend over long periods of time

The use of insulating material other than air between calorimeter and jacket should be avoided on account of the large lag of such material in coming to temperature equilibrium, and the resulting uncertainty in the heat loss correction [12, 1914, 57, 1928] The use of radiation shields of considerable heat capacity between calorimeter and jacket should be avoided for the same reason The use of very light shields for reducing heat transfer has been discussed by White [57, 1928].

Heat loss by convection and conduction through air may be reduced by means of a vacuum jacket This is most easily secured by using a vacuum bottle for the calorimeter Such a calorimeter, arranged for measurements of specific heats of liquids, by the method of electrical heating, is illustrated in Fig 2 The vacuum, and consequently the heat transfer coefficient, is likely to be different in different bottles According to White [57, 1928] the thermal leakage in a vacuum bottle may be anywhere from $\frac{1}{4}$ to $\frac{1}{2}$ that in an air-jacketed calorimeter of the same size

The principal advantages of the vacuum bottle are its low heat leakage and its low cost The disadvantages are the lag of the glass parts above the liquid surface, the variation in the effective heat capacity of the glass with height of liquid, the difficulty in fitting tight covers to both calorimeter and jacket, and the restrictions imposed by the shape and brittleness of the vessel [57, 1928] Serious errors are likely to result from the first three of these disadvantages unless precautions are taken to avoid them The effect of the lag of the glass parts above the liquid surface can be partially eliminated by an experimental calibration as described below The variation in effective heat capacity

can be eliminated by keeping the liquid level constant by means of the overflow device illustrated in Fig 2 [14, 1909] A tight cover such as that illustrated in Fig 2 can usually be fitted to the jacket, and if the temperature of the calorimeter is kept always below that of the jacket, the effect of evaporation from the calorimeter will be reduced to a minimum

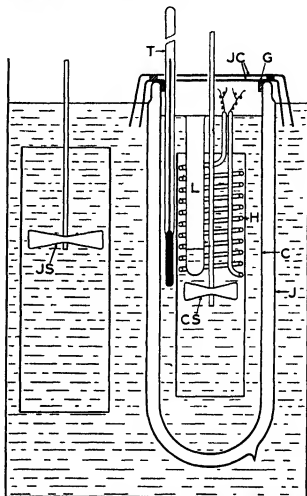

Fig 2 Vacuum-jacketed calorimeter arranged for measurements of specific heat of liquids C, calorimeter, J, jacket, JC, jacket cover, G, gasket, T, thermometer, S, calorimeter stirrer, JS, jacket stirrer, L, overflow device for maintaining constant height of liquid in calorimeter, H, heating coil

The heat measured by a calorimeter such as that illustrated in Fig 1 is given by the relation

$$Q = C \Delta \theta, \quad (1)$$

where Q is the heat measured, $\Delta \theta$ the rise in temperature of the calorimeter corrected for heat transfer and for heat of stirring, and C is a constant usually called the heat capacity or energy equivalent of the calorimeter and contents Only in the case of measurements of the order of 1% can C be calculated from the masses and specific heats of the materials of which the calorimeter is made An experimental calibration is essential for work of high precision, particularly as it largely eliminates certain systematic errors, such as those arising from lag in the convection currents between calorimeter and jacket, and from uncertainty as to the exact location of the boundary of the calorimeter.

An experimental calibration is carried out by adding a known quantity of heat to the calorimeter and observing the temperature rise produced. The heat capacity may then be calculated from equation (1). The heat may be supplied electrically or chemically, for example, a bomb calorimeter may be calibrated by burning a known mass of a standard substance such as benzoic acid, the heat of combustion of which has been accurately measured. This is probably the most satisfactory method of calibrating bomb calorimeters.

A diagram of the circuits used for an electrical calibration is shown in Fig 3. Current from a storage battery flows through either the heater H in the calorimeter or through a stabilizing resistance S (approximately equal to

charge of combustible is usually ignited by passing an electric current through a short length of fine platinum or iron wire placed just above the charge. Corrections which may be necessary include those for the electrical energy used to ignite the charge, for the heat of combustion of the wire if iron wire is used, for the heat of formation of nitric acid if the oxygen used contains nitrogen as an impurity, and for the heat of formation of sulphuric acid if the combustible material contains sulphur. For very accurate work precautions must be taken to make sure that the oxygen is free from combustible impurities, and corrections must be applied to take account of the change in internal energy with pressure of the oxygen and products of combustion, and the heat of solution of oxygen and carbon dioxide in the water in the bomb [52, 1933]. Details of methods of making measurements with the bomb calorimeter are given in a number of publications [12, 1914, 27, 1928, 29, 1934].

Accurate measurements of the heats of combustion of a gas are most readily made by burning the gas at a constant pressure of 1 atm in oxygen in a reaction chamber immersed in the water of a calorimeter. Such measurements on a number of pure gases have been described by Rossum [47, 1931]. Oxygen and the gas to be burned were fed into the reaction chamber at a constant rate, the gas was ignited by means of a spark and burned in a steady flame. The mass of gas burned was determined from the mass of water or carbon dioxide formed in the combustion.

Stirred liquid calorimeters have been used by several workers to measure heat content of oils and other fluids by the method of mixtures. The fluid was heated to the desired temperature in a boiler located outside the calorimeter, and was then caused to flow through a tube into a vessel immersed in the calorimetric liquid. The heat content of the fluid at its initial temperature, less that at the final temperature, was calculated from the relation

$$\Delta H = \frac{C\Delta\theta}{M}, \quad (3)$$

where C is the initial heat capacity of the calorimeter system $\Delta\theta$ the corrected temperature rise, and M the mass of fluid. The principal source of uncertainty in such measurements is in the correction for heat conducted from boiler to calorimeter along the tube joining them, and for heat loss from this tube. It has been shown by Swann [51, 1910] that the heat flow from boiler to calorimeter along the tube joining them will be much less when the fluid is flowing through this tube than during the rating periods in which heat leakage is measured. Richards and Mathews [33, 1917, 44, 1911] obtained satisfactory results for the heat content of saturated water vapour by this method by making observations at various rates of flow of vapour to the calorimeter, and extrapolating to infinite rate of flow. The results of Richards and Mathews have been discussed by Fiock [20, 1930].

Measurements of heat contents of petroleum products

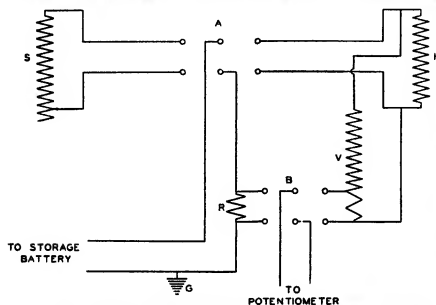

Fig 3 Diagram of connexions, measurements of electrical energy H , heater in calorimeter, S , stabilizing resistance, R , standard resistance, V , volt box, A , B , switches, G , ground

H), depending on which way the switch A is thrown. Current is measured by means of a potentiometer and standard resistance R , and the potential drop across the heater H is measured by means of the potentiometer and the volt box V . The heat capacity C of the calorimeter in international joules per degree is calculated from current I , voltage E , time of heating t , and corrected temperature rise $\Delta\theta$ of the calorimeter by means of the relation

$$C = \frac{EIt}{\Delta\theta} \quad (2)$$

Measurement of time is likely to be one of the most difficult measurements with this method. Thus for a heating time of 4 min the time must be measured to 0.2 sec to give an accuracy of 0.1%. Switches actuated by signals from standard clocks, and giving the time interval to about 0.01 sec, have been described by White [54, 1910] and by Osborne, Stumson, and Fiock [39, 1930]. Details of the method of carrying out electrical calibrations are given in a number of publications [12, 1914, 27, 1928, 29, 1934, 47, 1931, 54, 1910].

Heats of combustion of solids and liquids of low volatility are measured by burning a charge of the material in a constant-volume bomb in oxygen under an initial pressure of 20–40 atm. Where a liquid is so volatile that its evaporation would introduce serious errors the charge may be enclosed in thin-walled glass capsules flattened on opposite sides as described by Richards [43, 1910]. The

in the liquid and vapour phases at temperatures up to 1,000° F have been made by Weir and Eaton [53, 1932] by a method somewhat similar to that outlined above. The oil was heated to the desired temperature by causing it to flow through a coil of pipe in an electrically heated furnace. From the furnace the oil flowed through a tube to a heavily lagged valve, from which it flowed either to a condenser or through a short tube to the calorimeter. The temperature of the oil was measured by a thermocouple, one junction of which was located in the valve.

The calorimeter consisted of a vacuum bottle which initially contained crushed ice at a temperature somewhat below the freezing-point. Somewhat more than enough oil was admitted to the calorimeter to melt all the ice. The heat added to the calorimeter was measured by the heat of fusion of the ice, and the temperature changes of ice, water, and calorimeter.

This method has the advantage that the oil is heated for only a short time so that cracking is reduced to a minimum. The quantities of heat measured in the experiments of Weir and Eaton (as much as 50,000 calories in some experiments) were so large that heat loss and heat of stirring were relatively small, and did not need to be accurately known.

The principal disadvantages of the method are the uncertainty in the correction for heat flow along the tube through which the oil entered the calorimeter, and the difficulty of determining the initial temperature of the ice.

Weir and Eaton tested their method by making measurements of heat content of steam at atmospheric pressure and at temperatures ranging from 300 to 1,000° F, and obtained values which averaged 1.3% higher than values taken from steam tables. The corresponding error in the measurements on oils may have been greater than this if part of the systematic error in the results on steam was due to error in measuring the initial temperature of the steam, for an error of 5° F, for example, in the measurement of the initial temperature introduces an error of about 0.7% in the heat content of oil vapour, but only 0.2% in the heat content of steam.

A stirred liquid calorimeter for measurements of heats of hydrogenation of organic compounds has been described by Kistiakowski and his associates [30, 1935]. The calorimeter was of the Richards' 'submarine' type, and the calorimetric liquid, diethylene glycol, was stirred by a screw propeller stirrer driven by a synchronous motor. The jacket was kept at the same temperature as the calorimeter. A glass reaction vessel containing a catalyst was immersed in the water of the calorimeter, and hydrogen and the gas to be hydrogenated were caused to flow through the reaction vessel at a constant rate. The temperature rise of the calorimeter resulting from a measured amount of the reaction was observed by means of a thermel. The calorimeter was calibrated electrically with an accuracy of about 0.03%, and was used to measure heats of hydrogenation of several olefinic hydrocarbons at about 80° C with an accuracy of about 0.1%.

Stirred liquid calorimeters have been used by numerous workers to measure specific heats of liquids by the method of electrical heating. One arrangement for such measurements is illustrated in Fig. 2. A known mass of the liquid is placed in the calorimeter, a measured quantity of heat is supplied electrically, and the resulting temperature-change of the system is observed. The quantity of heat supplied is calculated as described previously from measurements of current, voltage, and time. Methods of correcting for

heat loss and heat of stirring are the same as those mentioned previously.

The heat capacity of the calorimeter is usually determined by filling it with a known mass of water, measuring the heat capacity of the system, and subtracting the heat capacity of the water from that of the entire system. The specific heats of liquids determined in a calorimeter calibrated in this way are necessarily expressed in terms of the specific heat of water [14, 1909].

Measurements of specific heats of liquid oils by the method just described have been made by Cragoe [11, 1929], by Fortsch and Whitman [21, 1926], and by Baily and Edwards [3, 1920]. A somewhat similar method was used by Bushong and Knight [9, 1920] and by Graefe [23, 1907], the heat being supplied, not electrically, but by combustion of benzoic acid in a calorimetric bomb.

One variation of the method of electrical heating, which has been used by some experimenters, consists in heating continuously, measuring the power input, and measuring the temperature at definite time intervals. It has been found that values of specific heat obtained in this way may be in error by as much as 10%.

IV. Aneroid Calorimeters

The aneroid or unstirred calorimeter depends on conduction and convection rather than stirring to distribute the heat. This type of calorimeter was developed by Eucken [17, 1909], and has been used by Dickinson and Osborne [15, 1915, 38, 1917] and their associates at the National Bureau of Standards for accurate measurements of specific heats, heats of fusion, and heats of vaporization of pure compounds. One calorimeter of this type is illustrated in Fig. 4. It consisted of the metal shell *S*, having a re-entrant central tube *T*, in which were located an electric heater and a platinum resistance thermometer. The shell was made in two parts which were threaded, one with a left-hand and one with a right-hand screw thread, and which were drawn together by the correspondingly threaded band *C*. The calorimeter was enclosed by the jacket *J*, which was immersed in a stirred liquid bath. The calorimeter was operated adiabatically. The temperature difference between calorimeter and jacket and the temperature distribution over the surface of the calorimeter were measured by means of thermocouples attached to the surfaces of calorimeter and jacket.

The material under investigation was contained in the annular space between the central tube and the shell of the calorimeter, and the heat was distributed by conduction in radial metal vanes, and by convection if the contents of the calorimeter were fluid.

To measure the specific heat of a liquid under saturation conditions the calorimeter was partially filled with the liquid under the saturation pressure of its vapour, a measured quantity of heat was supplied electrically, and the resulting rise in temperature of the system was observed. From the total quantity of heat supplied was subtracted the heat required to raise the temperature of the calorimeter and of the vapour present. Corrections were applied to the results to take account of the small amount of evaporation or condensation necessary to maintain saturation conditions. To measure the specific heat of a liquid at constant pressure the calorimeter was completely filled with the liquid which was maintained at a constant pressure greater than saturation pressure. Heat was supplied and the temperature rise observed as in the previous case. In this experiment there is no evaporation or condensation, but

It was necessary to take account of the mass and temperature of the liquid which flowed out of the calorimeter as a result of thermal expansion

To measure the heat of vaporization of a liquid the calorimeter was partially filled with the liquid, heat was supplied

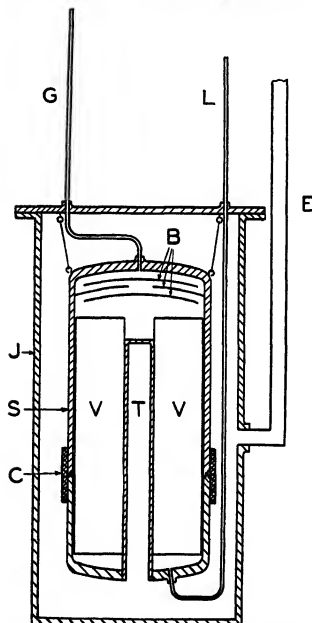

FIG. 4. Aneroid calorimeter. *J*, jacket, *S*, calorimeter, *T*, tube in which heater and resistance thermometer are located, *V*, metal vanes for distributing heat, *B*, baffles, *G*, *L*, tubes for introducing and removing gas and liquid, *E*, conduit for electrical leads, *C*, threaded band

at a constant rate, and vapour was removed at a rate sufficient to keep the temperature of the calorimeter constant. The vapour withdrawn from the calorimeter was condensed in a suitable container and its mass determined by weighing. The mass of liquid evaporated was greater than that of the vapour withdrawn by the amount of vapour required to fill the space from which liquid was evaporated. Hence a knowledge of the specific volumes of liquid and vapour was necessary to determine the mass of liquid evaporated.

The principal advantage of the aneroid calorimeter is

that with accurate measurements can be made over wide ranges of temperature and pressure. The principal disadvantage is that on account of the fact that there is no stirring the temperature of the calorimeter surface is not uniform while heat is being supplied to the calorimeter. Lack of temperature uniformity does not necessarily introduce any serious errors into the correction for heat leak, provided the thermocouples used to measure the temperature of the calorimeter surface are sufficient in number and suitably placed so as to give the average temperature of the surface.

Although it is possible to make accurate measurements with the aneroid calorimeter, the interpretation of the results of measurements will not always be so simple for a mixture such as an oil as for a pure compound. There appears to be no difficulty in the interpretation of results of measurements of the specific heat of liquid oils at constant pressure, but measurements of specific heat under saturation conditions are complicated by the fact that the evaporation (or condensation) which takes place when the temperature of the calorimeter is raised results in changes in composition of both liquid and vapour phases, and these changes will depend on the volumes of liquid and vapour in the calorimeter. The uncertainty caused by this effect is probably small at low temperatures, and probably can be made negligible at high temperatures by so adjusting the amount of fluid in the calorimeter that the mass of vapour remains approximately constant during an experiment. This adjustment, however, requires a knowledge of the densities of liquid and vapour phases under the conditions of the experiment. Measurements of heat of vaporization of oils are complicated by the fact that the specific volumes of liquid and vapour will change as vapour is withdrawn from the calorimeter, and consequently these specific volumes must be known as functions of the temperature and of the mass of vapour withdrawn from the calorimeter.

These difficulties are not peculiar to measurements with the aneroid calorimeter, but result from the fact that petroleum oils are mixtures rather than pure compounds. The same difficulties arise in other methods of measuring thermal properties of oils in the saturation region. They are mentioned here simply because the accuracy attainable with the aneroid calorimeter is so high that the uncertainty introduced by neglecting the effects mentioned may be large in comparison with errors of measurement.

Measurements of the specific heats of a number of petroleum oils have been made at the National Bureau of Standards by means of an aneroid calorimeter by Harrington, Green, and Snyder [24].

V. Flow Calorimeters

Flow calorimeters have been used extensively for measurements of specific heats of liquids and gases. The method of making such measurements consists essentially in causing the fluid under investigation to flow at a constant measured rate through the calorimeter where heat is added electrically at a constant measured rate, and observing the rise in temperature of the fluid.

The flow calorimeter illustrated in Fig. 5 was designed by Callendar [10, 1902] and used by Barnes [4, 1902] in measurements of the specific heat of water in the range 0 to 95°C. The water flowed through the glass tube *AB*, where it was heated by an electric heater. The enlargements at each end of this tube provided space for inlet and outlet platinum resistance thermometers T_1 and T_2 . The jacket was maintained at the temperature of the inlet water, and

the space between calorimeter and jacket was evacuated. Heat loss was determined by making measurements at different rates of flow and the same temperature rise. Barnes's measurements of specific heat of water are in agreement to 0.1% or better with the best modern measurements [20, 1930]. This type of flow calorimeter has been used by Lang and Jessel [32, 1930] for measurements of specific heats of liquid petroleum products in the range 0 to 100° C.

Flow calorimeters for measurements of thermal properties of oils at high temperatures have been described by Bahlke and Kay [1, 1929] and by Gary, Rubin, and Ward [22, 1933]. Both of these calorimeters were of massive construction and were heavily lagged with insulating material. Such massive construction and heavy lagging are very undesirable on account of the enormous time required to attain a steady state. The thermals used by Bahlke and Kay were exposed to the oil vapour and became contaminated, so that frequent calibration was necessary.

A high precision flow calorimeter for measurements of specific heats of gases has been described by Osborne, Stimson, and Sligh [40, 1924]. Heat losses were reduced to a minimum by (a) making the thermal resistance of the paths for metallic conduction as high as possible, (b) dividing the exposed surface of the calorimeter into two zones, one of which was kept at the initial and one at the final temperature of the gas, and surrounding these zones by shields kept at the same temperatures, and (c) evacuating the space between calorimeter and the protecting shields.

A schematic diagram of this calorimeter is shown in Fig. 6. The gas flowed from left to right through the central tube, passing first a platinum resistance thermometer T_1 , then an electric heater H , and finally a second resistance thermometer T_2 . The shield S_1 was kept approximately at the temperature of the incoming gas by being brought into intimate thermal contact with the central tube at a point where its temperature was practically unaffected by heat conducted back from the high-temperature part of the calorimeter. Any heat conducted back along the central tube and lost by radiation was intercepted by the shield S_1 and returned to the gas stream by metallic conduction. Similarly, the shield S_2 was kept at the final temperature of the gas by being brought into intimate thermal contact with the gas stream after passing the heater. The shields G_1 and G_2 were kept at approximately the same temperatures as the incoming and outgoing gas respectively. The heat loss was calculated from the small temperature difference between the shields G_1 and S_2 , which was measured by means of thermocouples. Tests of the corrections for heat loss were made by measurements of specific heat at different rates of flow of gas.

VI. Apparatus for Throttling Experiments

Measurements of the Joule-Thomson coefficient, that is, the change in temperature of a fluid when it is throttled from a high to a low pressure without loss or gain of heat,

yield data from which the change in heat content of the fluid with pressure can be calculated. The method used usually consists in forcing the fluid through a porous plug of porcelain or alundum, and observing the resulting change in temperature. To obtain accurate results, the pressures and the initial temperature of the fluid must be kept constant, and gain or loss of heat by the fluid between the thermometers on the high- and low-pressure sides of the plug must be avoided or corrected for.

Porous plugs and accessory apparatus for controlling temperatures and pressures and methods of making observations have been described by Burnett and Roebuck [8, 1910], by Roebuck [45, 1925], by Eumorfopoulos and Rai [19, 1926], and by Kleinschmidt [31, 1923]. Eucken, Clusius, and Berger [18, 1932] have described throttling

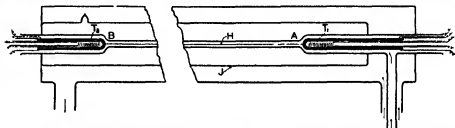

FIG. 5 Callendar-Barnes flow calorimeter. H , heater, J jacket, T_1 , T_2 , inlet and outlet resistance thermometers, A , B , glass tube



FIG. 6 Osborne-Stimson-Sligh flow calorimeter for specific heats of gases. T_1 , T_2 , inlet and outlet resistance thermometers, H , heater, S_1 , S_2 , shields in thermal contact with gas at initial and final temperatures, G_1 , G_2 , shields maintained at temperatures of S_1 and S_2 .

experiments in which the fluid after throttling was reheated to its initial temperature, and the rate of heating and rate of flow of fluid were measured.

Throttling experiments on oil vapours have been described by Weir and Eaton [53, 1932]. Temperatures and pressures apparently were not controlled. The temperature of the vapour before throttling was measured by two thermocouples which gave results differing by several degrees. The apparatus was tested by observing the temperature drop when superheated steam was throttled from 90 lb per sq in to 2 lb per sq in gauge pressure. The observed temperature drop increased from 2 to 7° F when the initial temperature was raised from 750 to 1,000° F, whereas according to data given in steam tables the temperature drop should have decreased from about 15 to 11° F. These facts indicate that the apparatus described by Weir and Eaton is not suitable for accurate measurements by the Joule-Thomson coefficient.

VII. Apparatus for Pressure-Volume-Temperature Measurement

Two types of apparatus have been used for pressure-volume-temperature measurements. In one type, illustrated schematically in Fig. 7, a known mass of the fluid under investigation is confined in a glass tube over mercury, and the volume of the fluid can be varied by introducing or removing mercury. This type of apparatus is suited to measurements of the change of volume with pressure at various constant temperatures. Apparatus similar to that illustrated in Fig. 7 has been used by Bahlke and Kay [2,

1932], for p - v - t measurements on a gasoline and a naphtha in the liquid, saturation, and superheat regions The tube T (Fig 7) was enclosed by a larger glass tube, and

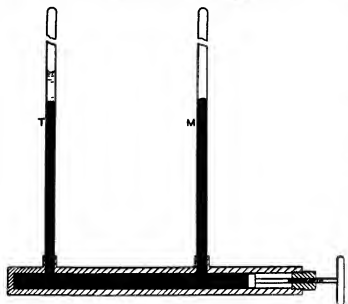

FIG 7 Apparatus for p - v - t measurements T , piezometer tube, M , closed end manometer

was maintained at various constant temperatures by admitting the vapours of a series of boiling organic liquids into the annular space between the two tubes Pressure was measured by means of closed-end manometers The volume was measured by observing the position of the mercury meniscus in the tube T Sage, Schaafsma, and Lacey [48, 1934] have used apparatus similar in principle to that illustrated in Fig 7 for p - v - t measurements on propane

An error may be introduced into such measurements by a film of liquid adhering to the wall of the tube T below the mercury meniscus, resulting in a value for the volume of the fluid which is too small This error was probably negligible in the measurements mentioned above, but might be appreciable with more viscous liquids If appreciable, the error could be detected by making measurements in tubes of different diameters

Where it is not necessary to observe the volumes of two phases, as in measurements on liquids under pressures greater than saturation, the error from a film of liquid adhering to the wall of the tube can be avoided by confining the liquid over mercury in one arm of a U tube and applying pressure by admitting a gas under pressure into the space over the mercury in the other arm Changes in volume are observed by noting changes in position of the meniscus in contact with the gas Measurements of compressibility and thermal expansion of liquid petroleum

products by this method have been described by Jessup [28, 1930]

The second type of apparatus, which is suitable for p - v - t measurements on superheated vapours, is illustrated in Fig 8, and consists essentially of a constant-volume gas thermometer A known mass of the gas under investigation is enclosed in the container A , which is immersed in a stirred liquid bath Measurements of pressure are made at various temperatures along a constant-volume line It is necessary to keep the manometer M and the connecting tube B at a temperature higher than that at which liquid will condense under the pressure existing in the apparatus A correction is necessary to take account of the fact that the gas in M and B is at a temperature different from that of the gas in A The volume of B and the volume of gas in M should be as small as possible in order that this correction shall not be excessively large This type of apparatus appears not to have been used for measurements on oil vapours The apparatus illustrated in Fig 8 was used by Meyers and Jessup [34, 1925] in measurements on ammonia

Measurements with both of the types of apparatus described above are subject to errors due to adsorption of a layer of gas on the walls of the containing vessel Such errors, if appreciable, may be detected by making measurements in containers having widely different ratios of wall surface to volume [34, 1925]

Apparatus and methods of making p - v - t measure-

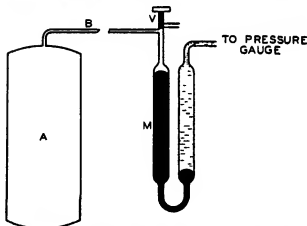

FIG 8 Constant-volume gas thermometers for p - v - t measurements on gases A , gas container, M , manometer, B , connecting tube, V , valve

ments at pressures up to 12,000 atm have been described by Bridgman [6, 1931, 7, 1931] The apparatus and methods described by Bridgman have been used by Dow and Fenske [16, 1935] for p - v - t measurements on petroleum oils over the pressure range of 1-4,000 atm

REFERENCES

1. BAHLKE, W H., and KAY, W B. *Ind Eng Chem* 21, 942 (1929)
2. ———. *Ind Eng Chem* 24, 291 (1932)
3. BAILEY, H S., and EDWARDS, C B. *Ind Eng Chem* 12, 892 (1920)
4. BARNES, H T. *Phil Trans Roy Soc Lond* 199A, 147 (1902)
5. BAREY, F. *J A C S* 46, 859 (1922)
6. BRIDGMAN, P W. *The Physics of High Pressure*. The Macmillan Co., New York (1931)
7. ———. *Proc Amer Acad Arts and Sci* 66, 185 (1931)
8. BURNETT, E S., and ROEBUCK, J R. *Phys Rev* 30, 529 (1910)
9. BURHONG, F W., and KNIGHT, L L. *Ind Eng Chem* 12, 1197 (1920)
10. CALLENDAR, H L. *Phil Trans Roy Soc Lond* 199A, 55 (1902)
11. CRAIG, C S. U S Bureau of Standards Misc Pub no 97 (1929)
12. DICKINSON, H C. *U S Bur Stand Bull* 11, 189 (1914)
13. DICKINSON, H C., and MUELLER, E F. *U S Bur Stand Bull* 9, 483 (1913)

- 14 DICKINSON, H C, MUELLER, E F, and GEORGE, E B *U S Bur Stand Bull* 6, 379 (1909)
- 15 DICKINSON, H C, and OSBORNE, N S *U S Bur Stand Bull* 12, 23 (1915)
- 16 DOW, R B, and FENKLE, M R *Ind Eng Chem* 27, 165 (1935)
- 17 EUCKEN, A *Physik Z* 10, 586 (1909)
- 18 EUCKEN, A, CLUSIUS, K, and BERGER, W *Z fur Techn Physik*, 13, 267 (1932)
- 19 EUMORFOPOULOS, N, and RAL, J *Phil Mag* 2, 961 (1926)
- 20 FLOCK, E F *Bur Stand J Res* 5, 481 (1930)
- 21 FORTICHI, A R, and WHITMAN, W G *Ind Eng Chem* 18, 795 (1926)
- 22 GARY, W W, RUBIN, L C, and WARD, J T *Ind Eng Chem* 25, 178 (1933)
- 23 GRAEFF, F *Petr Z* 2, 521 (1907)
- 24 HARRINGTON, E A, GIFFIN, C B, and SNYDER, E H Unpublished
- 25 JAEGER, W, and VON STEINWEHR, H *Verh der deutsch phys Ges* 5, 50, 353 (1903)
- 26 ——— *Ann der Phys* 21, 23 (1906)
- 27 ——— *Z fur physik Chem* 125, 305 (1928)
- 28 JESUP, R S *Bur Stand J Res* 5, 985 (1930)
- 29 JESUP, R S, and GREEN, C B *J Res Nat Bur Stand* 13, 469 (1934)
- 30 KISTIAKOWSKI, G B, ROMEYN, H, JR., RUHOFF, J R, SMITH, H A, and VAUGHN, W E *J A C S* 57, 65 (1935)
- 31 KLEINSCHMIDT, R V *Mech Eng* 45, 165 (1923)
- 32 LANG, H R, and JESSEL, R *J I P T* 16, 476 (1930)
- 33 MATHEWS, J H *J Phys Chem* 21, 536 (1917)
- 34 MEYERS, C H, and JESUP, R S *Refrig Eng* 11, 345 (1925)
- 35 MUELLER, E F *Mech Eng* 52, 139 (1930)
- 36 MUELLER, E F *U S Bur Stand Bull* 13, 547 (1916)
- 37 ——— Quoted by H C Dickinson, reference 12
- 38 OSBORNE, N S *U S Bur Stand Bull* 14, 133 (1917)
- 39 OSBORNE, N S, STIMSON, H F, and FLOCK, E F *Bur Stand J Res* 5, 411 (1930)
- 40 OSBORNE, N S, STIMSON, H F, and SLIGH, T S, JR *Sci Papers Bur Stand* 20, 119 (1924)
- 41 *Premier Rapport de la Commission Permanente de Thermochimie* Union Internationale de Chimie, 94 Rue des Mathurins, Paris (1934)
- 42 RICHARDS, T W, HENDERSON, L F, and FORBES, G S *Proc Amer Acad* 41, 3 (1905)
- 43 RICHARDS, T W, and JESSE, R H *J A C S* 32, 268 (1910)
- 44 RICHARDS, T W, and MATHEWS, J H *J A C S* 33, 863 (1911)
- 45 ROEBUCK, J R *Proc Amer Acad* 60, 538 (1925)
- 46 ROSSINI, F D *Chem Rev* 18, 233 (1935)
- 47 ——— *Bur Stand J Res* 6, 1, 37 (1931)
- 48 SAGE, B H, SCHAAPFMA, J G, and LACEY, W N *Ind Eng Chem* 26, 1218 (1934)
- 49 SLIGH, T S, JR *Sci Papers Bur Stand* 17, 49 (1922)
- 50 SMITH, F E *Phil Mag* 24, 541 (1912)
- 51 SWANN, W F G *Phil Trans Roy Soc Lond* 210A, 199 (1910)
- 52 WASHBURN, E W *Bur Stand J Res* 10, 525 (1933)
- 53 WEIR, H M, and EATON, G L *Ind Eng Chem* 24, 211 (1932)
- 54 WHITE, W P *Phys Rev* 31, 686 (1910)
- 55 ——— *J A C S* 36, 1856 (1914)
- 56 ——— *J A C S* 36, 1858 (1914)
- 57 ——— *The Modern Calorimeter* Reinhold Publishing Corp., New York (1928)
- 58 ——— *Rev Sci Inst* 4, 142 (1933)

HEAT OF COMBUSTION OF PETROLEUM OILS

By D. W. GOULD

The complete combustion of hydrocarbon material to carbon dioxide and water, together with an accurate measurement of the heat evolved, is readily accomplished. The determination of the calorific value at constant volume is made with a bomb calorimeter. The principles, design, and manipulation are so simple that results reported by conscientious observers are probably correct within 1%.

In most practical applications of the combustion of petroleum products, the process is carried out at constant pressure, generally atmospheric, and not at constant volume. The water vapour formed in the combustion is, moreover, not condensed. The heat liberated by the combustion of unit mass of oil with oxygen under these conditions is termed the 'Nett Calorific Value at Constant Pressure', again assuming that the oil is initially in the liquid state.

It is this quantity of heat which is of most significance in comparing fuels and calculating the efficiencies of heating equipment, and it may be calculated from the gross calorific value by allowing for the latent heat of the water formed during combustion.

No consistent correlation of the calorific value of an oil with physical properties other than density has been found. It is apparent that it should vary with the carbon-hydrogen content, and that the approximate limits must lie between methane and heavy residues represented as C_nH_m (n being large).

Cragoe's correlation [6a, 1929] of the heats of combustion of petroleum with their densities is sufficiently accurate for practical purposes. In the equation

$$Q_v = 12,400 - 2,100d^2,$$

where Q_v = gross calorific value at constant volume, gramme calories per gramme,

$$d = \text{specific gravity } 60/60^\circ F$$

The error involved in assuming that the equation holds for densities in grams per ml at $20^\circ C$ is of the order 0.1%. Unless stated otherwise, the values given in the table are gross or higher heating values.

Cragoe gives equations for calculating net calorific values from the gross figures and for allowing for the sulphur con-

tent, &c, when figures are to be expressed on an ash, water, sulphur free basis.

The formula cannot be applied to all classes of petroleum products with equal expectation of accurately predicting the calorific value. Light, straight-run distillates deviate least from the equation, cracked residuum conforms poorly. The method of presentation has been to give a sufficiently wide distribution of petroleum oils (geographically and densimetrically) so that the estimation of the calorific value of a sample of known density may be qualified in the light of known departure or adherence to the equation. The tabulated data is divided into crudes, gasolines, kerosenes, and refined oils, gas oils, Diesel fuels, and fuel oils. The designation has followed that given by the original investigator. The overlapping of the group characteristics is obvious. The tabulated data include origin (when known), density ($20^\circ/4^\circ C$), gross heating value expressed as B Th U per pound and as calories per gram, deviation of the experimental value from the result predicted by Cragoe's equation, and in some instances an ultimate analysis. These ultimate analyses are shown in Table VII. The data for all the oils are summarized. The symbol NS in the data denotes that field was not stated.

Table no	Class	Number of oils	Deviation of experimental determination of gross heating value from Cragoe's equation
1	Crude petroleum		%
	Asia	11	+3.39
	Europe	27	+0.89
	North America	53	-1.14
	South America	8	+0.17
	Average	99	+0.02
2	Gasolines	34	-0.26
3	Kerosenes and refined oils	15	+0.40
4	Diesel fuels	24	-0.09
5	Gas oils	9	-0.43
6	Fuel oils		
	Asia	1	+1.63
	Europe	7	+1.07
	North America	74	-0.86
	South America	7	-1.26
	Average	89	-0.71

TABLE I
Gross Calorific Value of Crude Petroleum

Origin of petroleum	Density $20^\circ/4^\circ C$	B Th U per lb	Calories per g	Deviation from formula %	Analysis no	Authority reference
ASIA						
Borneo						
Sarawak	0.898	19,368	10,760	+0.64	1	14
India						
Rangoon	0.863	18,882	10,489	-3.17	2	27
Japan						
Koguchi	0.925	20,671	11,484	+7.82		19
Kuodasu	0.921	20,626	11,459	+7.47		19
Kitadai	0.895	20,500	11,389	+6.03		19

PHYSICAL AND CHEMICAL PROPERTIES

TABLE I (cont)

Origin of petroleum	Density 20°/4° C	B Th U per lb	Calories per g	Deviation from formula %	Analysis no	Authority reference	
ASIA							
Japan (cont)							
Miyagawa	0 891	20,945	11,636	+7 88		19	
Katsubo	0 877	20,477	11,376	+5 32		19	
Ileri	0 866	20,306	11,281	+4 17		19	
Amaze	0 818	20,533	11,407	+3 73		19	
Java							
N S	0 910	18,989	10,548	-0 93	3	27	
N S	0 863	19,180	10,654	-1 57	4	4	
Average deviation for 11 Asiatic samples = +3 39%.							
EUROPE							
Poland (Galicia)							
Harklowa	0 899	20,012	11,118	+3 87		9	
Urycz	0 882	19,966	11,092	+3 96		9	
Mrazuca	0 876	19,903	11,057	+2 54		9	
Kosmacz	0 863	19,966	11,092	+2 44		9	
Tustanowicz	0 859	20,263	11,257	+3 74		9	
Wankowa-Brelkow	0 850	20,203	11,224	+3 18		9	
N S	0 851	19,532	10,851	-0 13	5	9	
Schodnia	0 846	19,958	11,088	+1 85		9	
Boryslaw	0 845	19,915	11,064	+1 62		9	
Rumania							
N S	0 936	18,920	10,511	-0 31	6	5	
N S	0 886	19,152	10,640	-0 90	7	5	
Mereni	0 884	18,864	10,480	-2 45	42	23	
Bacou	0 877	18,891	10,495	-2 55	43	23	
Montesti	0 865	19,253	10,696	-1 09	44	23	
Campina (non-paraffinic)	0 856	19,015	10,564	-2 64	45	23	
" (paraffinic)	0 851	19,328	10,738	-1 17	46	23	
Filipesti	0 848	19,474	10,819	-0 53	47	23	
Buzeniari	0 838	19,006	10,559	-3 22	48	23	
Policiori	0 825	19,354	10,752	-1 89	23	23	
Russia (Europe and Asia)							
Turukan	0 944	18,877	10,487	-0 25		7	
Caucasian	0 936	18,516	10,285	-2 45	9	27	
Circassian, Heavy	0 925	20,850	11,582	-0 06	10	27	
N S	0 898	19,364	10,758	+0 63	11	5	
Circassian, Light	0 873	22,027	12,236	+13 45	12	27	
Baku	0 873	20,450	11,360	+3 34	27	27	
N S	0 872	19,543	10,857	+0 73	13	5	
N S	0 867	19,500	10,832	+0 23	14	4	
Average deviation for 27 European samples = +0 89%.							
NORTH AMERICA							
Canada							
N S	0 855	19,420	10,788	-0 58	18	4	
N S	0 848	19,424	10,790	-0 80	19	27	
Mexico							
N S	0 966	18,182	10,101	-3 19	20	5	
N S	0 936	18,536	10,298	-2 39	21	5	
Trinidad, B W I							
N S	0 941	18,360	10,200	-3 19		7	
California							
N S	0 960	18,589	10,326	-1 17	24	1	Samples inspected
Sunset	0 958	18,478	10,265	-1 83	1	25	
Kern River	0 952	18,553	10,306	-1 67	1	40	
Summerland	0 953	18,544	10,301	-1 68	2	6	
Los Angeles	0 951	18,443	10,245	-2 30	2	22*	
McKittrick	0 950	18,508	10,281	-1 98	1	26	
Santa Fe	0 949	18,210	10,116	-3 59	2	17	
Midway	0 945	18,613	10,340	-1 61	1	29	
"	0 918	19,255	10,697	+0 77	28		
Coalinga	0 938	18,727	10,403	-1 26	1	62	
Sunset	0 931	18,706	10,391	-1 64	2	31	
Coalinga	0 927	18,558	10,309	-2 56	2	56	
Whittier	0 927	18,808	10,448	-1 25	2	18	
Midway	0 919	18,755	10,418	-1 82	2	16	
Newhall	0 913	18,845	10,468	-1 56	2	9	
N S	0 912	18,572	10,317	-3 01	24	1	
Brea Canyon	0 911	18,572	10,417	-2 11	2	9	

HEAT OF COMBUSTION OF PETROLEUM OILS

1235

TABLE I (cont)

Origin of petroleum	Density 20°/4° C	B Th U	Calories per lb	Deviation from formula %	Analysis no	Authority reference	Samples inspected
NORTH AMERICA California (cont)							
Fullerton	0 909	18,790	10,438	- 1 98		2	11
Bardsdale	0 907	17,307	9,614	- 9 80		2	6
Piru	0 903	18,604	10,335	- 1 17		2	13
Santa Maria	0 894	18,720	10,399	- 2 88		2	40
Santa Paula	0 891	18 834	10,462	2 37		2	7
Sespe	0 884	19,001	10 555	- 1 76		2	6
Puenic Hills	0 880	19,066	10 591	- 1 56		2	9
Illinois							
N S	0 856	19,379	10,765	- 1 68		24	
Kansas							
N S	0 907	19,303	10 723	1 0 60		24	
N S	0 903	19,089	10,604	- 0 64		24	
N S	0 879	19,249	10,693	- 0 65		24	
N S	0 876	19,447	10,803	+0 27		24	
N S	0 854	19,389	10 771	- 0 76		24	
N S	0 847	19,724	10,957	+ 0 72		24	
Michigan							
Mt Pleasant	0 820	19,748	10,971	- 0 03		29	
N S	0 811	19,600	10,889	- 1 05		30	
Ohio							
N S	0 838	19,710	10,949	+ 0 35		24	
N S	0 801	20,068	11,148	+0 99		24	
Oklahoma							
N S	0 886	19,418	10,787	1 0 46		24	
N S	0 882	19,454	10 807	+ 0 52		24	
N S	0 865	19,534	10,851	+ 0 34		24	
N S	0 843	19,685	10 935	+ 0 39		24	
N S	0 840	19,508	10,837	- 0 61		29	
N S	0 838	19,795	10,996	+ 0 78		24	
Pennsylvania							
N S	0 828	19,782	10,989	+ 0 39		24	
N S	0 802	20,057	11,142	+ 0 96		24	
Texas							
N S	0 943	18,945	10,524	+ 0 07	22	4	
N S	0 930	19,080	10,599	1 0 29		24	
N S	0 912	19,246	10,691	1 0 50		24	
N S	0 910	19,028	10 570	+ 0 22		24	
N S	0 887	19,242	10,689	- 0 41		24	
Virginia							
N S	0 861	19,156	10,641	- 1 64	23	27	
West Virginia							
N S	0 822	20,021	11,122	+ 1 41		24	
N S	0 820	19,766	10,980	+ 0 06		24	
N S	0 791	20,030	11,127	+ 0 73		24	
Average deviation for 53 North American oils = - 1 14%.							
SOUTH AMERICA							
Argentina							
San Rafael	0 989	18,538	10,299	- 0 29	15	5	
Comodoro Rivadavia	0 953	18,940	10 521	+ 0 42		4	
Patagonia	0 948	18,970	10 539	+ 0 40	16	5	
Comodoro Rivadavia	0 924	19 190	10,661	+ 0 66	17	5	
Arguarray	0 923	18,950	10,527	- 0 64		4	
Nuequen	0 911	18 920	10,510	- 1 17		4	
Tartagal	0 905	19,300	10,721	1 0 52		4	
Yacuva	0 894	19,550	10,860	+ 1 43		4	
Average deviation for 8 South American oils = - 0 17%							

PHYSICAL AND CHEMICAL PROPERTIES

TABLE II
Gross Calorific Value of Gasolines
(Arranged in order of Density)

Original	Density 20 °C	Btu per lb	Calorific per g	Density from formula	Analysis no	Authority reference
U S A NS	0 767	20 038	11 131	0 19		24
British NS	0 741	20 160	11 200	0 30	49	25
U S A NS	0 747	20 196	11 220	0 07		6
(15 C)						
California Midway Field Crude	0 746	20 330	11 294	0 68		78
Mid Continent	0 741	20 097	11 164	0 60		70
California	0 740	19 980	11 100	1 35		6
(15 C)						
Mid Continent	0 738	20 113	11 173	0 64		70
British NS	0 736	20 304	11 280	0 27	50	75
Borneo NS	0 736	20 087	11 158	0 83	E	71
Oklahoma NS (straight run)	0 731	20 068	11 149	1 03		9
U S A (Eastern) Casnghead	0 729	20 214	11 770	0 18		70
Sumatra NS	0 727	20 233	11 239	0 35	D	1
U S A NS	0 726	20 407	11 336	0 49		6
NS	0 725	20 401	11 333	0 44		6
Borneo NS	0 725	20 196	11 270	0 68		6
(15 C)						
U S A Mid Continent	0 723	20 198	11 220	0 73		0
Sumatra NS	0 723	20 340	11 300	0 0		6
(15 C)						
Michigan Mt Pleasant (straight run)	0 720	20 267	11 57	0 17		9
U S A Eastern	0 720	20 225	11 215	0 58		70
British NS	0 716	20 340	11 300	0 09	51	5
(Shell A)	0 716	20 357	11 306	0 05	C	1
NS	0 715	20 401	11 334	0 18	B	71
U S A NS	0 714	20 579	11 432	-1 02		6
Eastern	0 714	20 137	11 186	1 16		6
NS	0 713	20 340	11 300	0 79		6
(15 C)						
NS	0 713	20 477	11 375	0 48		6
German (Benz n)	0 712	20 082	11 157	1 49	4	15
U S A Mid Continent	0 711	20 250	11 249	0 69		0
NS	0 710	20 376	11 320	0 19		6
(15 C)						
NS	0 708	20 581	11 411	0 85		6
NS	0 706	20 120	11 177	1 47		74
NS	0 703	20 522	11 790	0 53		6
(15 C)						
NS	0 701	20 466	11 370	0 0		6
(15 C)						
British NS	0 692	20 736	11 519	+1 19	A	1
U S A NS	0 697	20 448	11 360	0 30		6
(15 C)						
Eastern	0 683	20 367	11 314	0 83		70
NS	0 681	20 646	11 470	+0 38		6
(15 C)						
Average deviation of 34 oils			0 26			

TABLE III
Gross Calorific Values of Kerosines and Refined Oils

Original	Density 20 °C	Btu per lb	Calorific per g	Density from formula	Analysis no	Authority reference
U S A NS	0 825	19 805	11 002	+0 73		1
Pennsa	0 820	19 950	11 082	+0 98		3
NS	0 810	19 810	11 004	0 05		3
Ecuador S A crude	0 808	19 940	11 077	+0 52		3
East Texas	0 807	19 900	11 054	+0 32		3
NS	0 796	19 872	11 039	-0 15		26
Pennsa	0 793	20 050	11 138	+0 65		3
NS	0 791	20 135	11 185	+0 94		24
British Mixed crudes NS	0 789	20 052	11 140	+0 55	66	25
Mixed crudes NS	0 789	20 160	11 200	+1 08	67	25
U S A NS	0 789	19 894	11 051	-0 25		26
British Distillate from mixed base mostly paraffinic NS	0 789	20 040	11 133	+0 48		16
U S A NS	0 787	19 922	11 067	-0 17		26
NS	0 779	20 018	11 120	+0 07		24
British, Mixed base crudes NS	0 776	20 070	11 150	+0 24	68	25
Average deviation for 15 oils			+0 40%			

HEAT OF COMBUSTION OF PETROLEUM OILS

1237

TABLE IV
Gross Calorific Values of Diesel Fuels
(Arranged in order of Density)

Origin of material	Density 20°/4° C	B Th U per lb	Calories per g	Deviation from formula %	Analysis no	Authority reference
Rumania, N S	0.949	18,788	10,438	-0.53	32	5
Russia, Baku	0.949	18,761	10,423	-0.67	33	5
Borneo, N S	0.947	18,819	10,455	-0.44	34	5
Rumania, N S	0.940	18,887	10,493	-0.34	35	5
" N S	0.928	19,046	10,581	+0.05	36	5
British, Residue from naphthenic base	0.925	19,250	10,693	+0.98	53	16
" Blend of distillate and residue from aromatic base	0.906	19,220	10,677	+0.15	54	16
" Blend of distillate and residue from naphthenic and aromatic bases	0.900	19,150	10,638	-0.43	55	16
British, Blend of distillate and residue from naphthenic and aromatic bases	0.892	19,300	10,721	+0.07	56	16
British, Residue from mixed bases, chiefly paraffinic	0.892	19,280	10,710	-0.04	57	16
Galicia, N S	0.883	19,357	10,754	+0.06	37	5
British, Blend of distillate and residue, chiefly paraffinic	0.873	19,390	10,771	-0.13	58	16
Galicia, N S	0.871	19,355	10,753	-0.36	38	5
British, Mixed base crudes, N S	0.866	19,764	10,980	+1.54	59	25
" Blend of distillate and residue, chiefly paraffinic	0.866	19,450	10,804	-0.07	60	16
Galicia, N S	0.863	19,530	10,850	+1.27	39	5
British, Distillate from mixed base crudes, mostly paraffinic, N S	0.863	19,500	10,832	+0.10	61	16
" Distillate from naphthenic base crude, N S	0.863	19,700	10,943	+1.02	62	16
Germany, Reichelbronn	0.852	19,390	10,772	-0.83	40	5
British, Distillate from naphthenic base crude, N S	0.851	19,675	10,929	+0.59	63	16
Galicia, N S	0.849	19,472	10,818	-0.50	41	5
British, Distillate from mixed bases, mostly paraffinic, N S	0.848	19,800	11,000	+1.13	64	16
" Gas oil from Scotch shale	0.829	19,700	10,943	0	65	16
" N S	0.789	20,040	11,132	+0.48	16	16

Average deviation of 24 oils = -0.09%

TABLE V
Gross Calorific Values of Gas Oils

Source	Density 20°/4° C	B Th U per lb	Calories per g	Deviation from formula %	Analysis no	Authority reference
Rumania, N S	0.888	19,076	10,598		24	5
Galicia, N S	0.886	19,294	10,719		25	5
Germany, N S	0.866	19,303	10,724		26	5
Mexico, N S	0.864	19,303	10,724		27	5
Galicia, N S	0.864	19,535	10,853		28	5
" N S	0.854	19,562	10,868		29	5
Germany, N S	0.852	19,447	10,804		30	5
British, Scottish shale oil	0.829	19,700	10,943		65	16
Germany, N S	0.791	19,780	10,989		31	5

Average deviation for 9 oils = -0.43%

TABLE VI
Gross Calorific Value of Fuel Oils
(S R = straight run, Cr = cracked)

Source	Density (D 20°/4° C)	B Th U per lb	Calories per g	Deviation from formula %	Authority reference
AMA					
Iran, N S	0.893	19,600	10,888	+1.63	8
Europe					
Galicia					
Uryez, Masut-Ostak	0.936	19,150	10,638	+0.88	4
" " "	0.929	19,200	10,666	+0.88	4
Boryslau, "	0.921	19,500	10,832	+2.11	4
Italy, N S	0.894	19,517	10,842	+1.25	11
Rumania, N S	0.924	19,004	10,558	-0.31	7
Russia, N S (Ostak)	0.916	19,044	10,580	-0.41	4
" N S (Ostak)	0.910	19,782	10,990	+3.13	4

Average deviation for 7 European oils = +1.07%

PHYSICAL AND CHEMICAL PROPERTIES

TABLE VI (cont)

Source	Density (D 20°/4° C)	B Th U per lb	Calories per g	Deviation from formula %	Authority reference
NORTH AMERICA					
Mexico					
Ebano (S R)	0 970	17,790	9,882	- 5 32	11
Trinidad, B W I	0 960	18,403	10,224	- 2 19	7
N S (S R)	0 959	18,459	10,254	- 1 93	11
N S (S R)	0 951	18,717	10,397	- 0 85	11
Arkansas					
Smackover (Cr)	0 987	18,152	10,083	- 2 54	11
Irma (S R)	0 937	18,473	10,262	- 1 94	11
Eldorado (S R)	0 941	18,695	10,385	- 1 35	11
California					
Ventura (Cr)	1 013	17,988	9,992	- 2 66	11
N S (Cr)	1 003	18,093	10,051	- 2 07	11
Ventura (Cr)	0 987	18,142	10,078	- 2 58	11
" (Cr)	0 977	18,205	10,113	- 2 63	11
N S (Cr)	0 952	18,328	10,182	- 2 94	11
N S (S R)	0 948	18,711	10,394	- 1 00	11
N S (S R)	0 939	18,801	10,444	- 0 85	11
Ventura (S R)	0 939	18,617	10,342	- 1 85	11
" (Cr)	0 938	18,611	10,338	- 1 91	11
N S (S R)	0 930	18,769	10,426	- 1 06	11
N S (S R)	0 910	19,080	10,599	- 0 44	11
N S (S R)	0 893	19,205	10,668	- 0 39	11
Ventura (S R)	0 875	18,954	10,529	- 2 37	11
Midway	0 938	19,090	10,605	+ 0 65	28
N S (Cr)	1 001	18,219	10,122	- 1 51	31
N S (blend of Cr and S R)	0 966	18,661	10,367	- 0 53	31
N S (S R)	0 937	18,925	10,514	- 0 26	31
Kansas					
N S (Cr)	1 003	18,162	10,089	- 1 68	11
N S (Cr)	0 999	18,347	10,192	- 1 06	11
N S (Cr)	0 981	18,461	10,255	- 1 05	11
Mixed S R from Greenwood, Rice, and Hayes Counties Crude	0 900	19,300	10,722	+ 0 36	32
Kentucky					
N S (Cr)	1 046	17,837	9,908	- 1 97	11
N S (S R)	0 905	19,226	10,680	+ 0 14	11
N S (S R)	0 904	19,358	10,753	+ 0 78	11
N S (S R)	0 897	19,223	10,678	- 0 16	11
Louisiana					
Bosco Crude	1 005	18,193	10,107	- 1 50	30
" "	1 004	18,216	10,120	- 1 42	30
" "	0 983	18,448	10,249	- 1 02	30
Oklahoma					
N S (Cr)	1 018	18,130	10,071	- 1 35	11
Seminole Crude	1 009	17,888	9,938	- 2 91	30
" "	0 979	18,465	10,238	- 1 09	30
" "	0 970	18,700	10,389	- 0 18	30
" "	0 970	18,580	10,322	- 0 83	30
" (S R)	0 948	18,811	10,450	- 0 45	11
" (S R)	0 926	19,008	10,559	- 2 01	11
N S (S R)	0 914	19,010	10,560	- 0 67	11
N S (S R)	0 895	19,211	10,672	- 0 29	11
Pennsylvania					
N S (Cr)	0 898	19,001	10,555	+ 1 55	11
Buckeye	0 884	19,660	10,921	+ 1 62	3
N S	0 873	19,429	10,793	+ 0 07	24
N S	0 863	19,530	10,849	+ 0 26	24
N S	0 861	19,636	10,919	+ 0 82	24
N S (Cr)	0 860	19,504	10,834	+ 0 02	11
N S (S R)	0 845	19,637	10,908	+ 0 20	11
Buckeye	0 833	19,840	11,021	+ 0 84	3
"	0 813	20,090	11,160	+ 1 45	3
Texas					
West Texas (Cr)	1 080	17,198	9,553	- 4 02	11
Winkler	0 965	18,355	10,307	- 1 17	3
East Texas	0 947	18,965	10,535	+ 0 32	3
Ranger	0 936	19,105	10,613	+ 0 65	3
N S (S R)	0 935	18,940	10,521	- 0 26	11
West Texas (S R)	0 931	18,767	10,425	- 1 33	11

HEAT OF COMBUSTION OF PETROLEUM OILS

1239

TABLE VI (cont)

Source	Density (D ₂₀ ¹⁵ C)	B Th U per lb	Calories per g	Deviation from formula %	Authority Reference
NORTH AMERICA TEXAS (cont)					
McCamey (S R)	0.923	18,867	10,481	-1.09	11
N S	0.922	18,790	10,438	-1.54	22
N S	0.919	19,490	10,827	+2.00	22
Penhandle (S R)	0.915	19,125	10,624	-0.02	11
N S	0.914	18,698	10,387	-2.35	22
N S (S R)	0.907	19,334	10,740	+0.76	11
Winkler	0.905	18,970	10,538	-1.21	3
"	0.872	19,375	10,763	-0.23	3
East Texas	0.861	19,585	10,879	+0.46	3
Ranger	0.855	19,745	10,968	+1.07	3
East Texas	0.848	19,680	10,932	+0.51	3
Ranger	0.836	19,935	11,074	+1.42	3
N S	0.835	19,320	10,732	-1.78	22
VanZandt Crude	1.028	17,896	9,942	-2.18	30
"	1.021	18,165	10,092	-0.99	30
"	1.011	18,273	10,152	-0.83	30
"	1.005	18,219	10,122	-1.38	30
"	1.003	18,263	10,146	-1.37	30
"	0.996	18,266	10,147	-1.48	30
"	0.989	18,215	10,119	-2.04	30
"	0.987	18,735	10,408	+0.68	30
"	0.978	18,006	10,003	-3.58	30
"	0.970	18,796	10,442	+0.35	30
"	0.968	18,700	10,388	-0.28	30
Coastal	0.937	19,544	10,858	-0.52	33
"	0.887	19,231	10,693	-0.36	33
"	0.866	19,378	10,765	-0.42	33
Mid-Continent, U S A					
N S (Cr)	1.003	18,162	10,089	-1.82	11
N S (Cr)	1.003	18,032	10,028	-2.42	11
N S (S R)	1.000	18,350	10,193	-0.76	11
N S (Cr)	0.991	18,293	10,162	-1.36	11
N S (Cr)	0.991	18,250	10,138	-1.81	11
N S (Cr)	0.988	18,225	10,124	-1.95	11
N S (Cr)	0.985	18,279	10,154	-1.78	11
N S (Cr)	0.972	18,404	10,223	-1.20	11
N S (Cr)	0.967	18,460	10,235	-1.42	11
N S (Cr)	0.945	18,604	10,335	-1.49	11
N S (Cr)	0.921	19,093	10,606	+0.03	11
N S (S R)	0.899	19,353	10,750	+0.57	11
N S (S R)	0.890	19,309	10,726	+0.03	11
N S (S R)	0.830	19,890	11,049	+1.00	11
Average deviation for 74 North American oils = -0.86%					
SOUTH AMERICA					
Argentina					
Comodoro Rivadavia (S R)	0.930	19,225	10,679	+1.04	11
" (S R)	0.917	19,014	10,562	-0.53	11
" (S R)	0.916	19,082	10,600	-0.22	11
Venezuela					
N S (S R)	0.967	18,242	10,133	-2.83	11
Mene Grande (S R)	0.963	18,285	10,157	-1.20	11
N S (S R)	0.961	18,408	10,226	-2.13	11
Mene Grande (S R)	0.955	18,303	10,167	-2.98	11
Average deviation for 7 South American oils = -1.26%					

TABLE VII
 Ultimate Analyses of Oils

Analyte no	Analyte no				Analyte no				Analyte no				Analyte no					
	C	H	N+O	S	C	H	N+O	S	C	H	N+O	S	C	H	N+O	S		
1	86.5	12.4			18	86.9	12.9		35	87.1	11.5	1.0	0.4	52	82.0	9.1	0.63	
2	83.8	12.7			19	86.9	12.9		36	86.6	11.7	1.4	0.3	53	87.6	11.4	0.16	
3	87.1	12.0			20	83.0	11.0	1.7	4.3	37	86.5	12.4	0.6	0.5	54	85.6	12.0	1.62
4	87.1	12.7			21	83.8	11.3	1.1	3.8	38	86.7	12.5	0.4	0.4	55	86.8	11.6	0.30
5	86.5	13.0	0.2	0.3	22	86.6	11.8			39	86.4	12.6	0.6	0.4	56	86.9	11.9	1.01
6	87.2	11.3	1.1	0.4	23	83.5	13.3			40	86.6	12.5	0.2	0.7	57	85.5	12.4	1.41
7	86.6	12.1	0.7	0.6	24	87.1	12.1	0.6	0.2	41	86.3	12.9	0.4	0.4	58	85.6	12.5	1.27
8	85.1	11.4			25	86.9	12.0	0.5	0.6	42	86.4	10.2	3.1	0.2	59	86.3	12.8	0.9
9	85.3	11.6			26	86.2	12.3	0.8	0.7	43	85.7	12.9	1.2	0.2	60	85.6	12.6	1.17
10	87.1	12.3			27	84.6	13.0	0.5	1.9	44	85.8	13.1	0.6	0.4	61	85.6	12.7	1.07
11	86.1	12.8	0.9	0.2	28	86.4	12.8	0.4	0.4	45	86.3	12.5	1.0	0.2	62	86.5	12.8	0.11
12	86.3	13.6			29	86.3	12.9	0.5	0.3	46	85.1	13.7	1.1	0.2	63	85.4	12.8	0.63
13	86.3	12.9	0.6	0.2	30	85.7	12.7	0.9	0.7	47	86.6	13.0	0.3	0.1	64	85.7	12.7	0.85
14	86.9	13.1			31	85.9	13.4	0.3	0.4	48	86.0	13.3	0.6	0.1	65	85.6	13.0	0.54
15	87.0	10.8	0.9	1.3	32	86.9	11.5	1.2	0.4	49	85.5	14.5	0.3	0.6	66	86.3	13.6	0.08
16	86.5	12.0	1.2	0.3	33	87.5	11.3	0.8	0.4	50	85.3	14.7	0.02	0.7	67	86.0	14.0	0.01
17	86.7	12.1	1.0	0.2	34	87.7	11.1	0.7	0.5	51	85.1	14.9	0.01	0.8	68	86.2	13.8	0.01

REFERENCES

- ALLEN, I C, and JACOBS, W A *U S Bur Mines Bull* 19 (1911)
- ALLEN, I C, JACOBS, W A, CROSFIELD, A S, and MATTHEWS, R R *U S Bur Mines Tech Paper* 74 (1914)
- Atlantic Refining Co., Philadelphia, Pa. Personal communication, 1933
- BRAME, J S S *Fuels* (London 1914, E Arnold)
- CONSTANT, E J, and SCHLAPFER, P *Zeit Verein deutsch Ing* 57, 1576 (1913)
- CRAGG, C S *Chaleur et Industrie*, 9, 337 (1928)
- *U S Bur Stand, Misc Pub* no 97, 14 (1929)
- Dingler's Polytech J* 328, 539 (1913)
- DUNSTAN, A E *Petr Times*, 11, 63 (12 Jan 1924)
- ENGLER, C, and HÖFER, H *Das Erdöl*, 3, 342 (Leipzig 1916, S Hirtzel)
- FARAGHER, W F, MORRELL, J C, and ESSEX, J L *Ind Eng Chem* 21, 933 (1929)
- GAVIN, M J, and SHARP, L H *U S Bur Mines R I* 2152 (1920)
- GAVIN, M J, and DEMOND, J S *U S Bur Mines Bull* 315 (1930)
- KEWLEY, J *Petr Times*, 11, 49 (12 Jan 1924)
- LANGHEIM, H *Z angew Chem*, 1259 (1900)
- LE MEURIER, L J, and STANFIELD, R *J I P T* 17, 387 (1931)
- PATTERSON, W H *J S C I*, 32, 218 (1913)
- PRECHT, J *Petr Z*, 4, 568 (1909)
- RAKUSIN, M A *Petr Z*, 6, 1050 (1911)
- RITTMAN, W F, JACOBS, W A, and DEAN, E W *U S Bur Mines Tech Paper* 163 (1916)
- Royal Aircraft Establishment, (British) Report no H, 161, *J I P T* 7, 342 (1921)
- SCOTT, A C *Coal Age*, 11, 658 (1917)
- SCHELLER, A *Petr Z*, 8, 730 (1913)
- SHERMAN, H C, and KROFFT, A H *J A C S* 30, 1627 (1908)
- SPIERS, H M *Technical Data on Fuel*, 2nd ed (London 1930)
- STRONG, R M, and STONE, L *U S Bur Mines Bull* 43 (1912)
- WELLS, G J, and WALLI-TAYLOR A *J Diesel or Slow-Combustion Oil Engine* (New York 1916, D Appleton & Co)
- COMMUNICATION from J B Terry (Standard Oil Co of California), 28 Oct 1935
- COMMUNICATION from E B McConnell (Standard Oil Co of Ohio), 9 Dec 1935
- COMMUNICATION from C R Wagner (Pure Oil Co), 11 Nov 1935
- COMMUNICATION from W F Van Senden (Shell Oil Co), 21 Nov 1935
- COMMUNICATION from R C Alden (Phillips Petroleum Co), 18 Oct 1935
- COMMUNICATION from J B Rather (Socony-Vacuum Oil Co), 23 Oct 1935

HEATS OF COMBUSTION OF HYDROCARBON GASES

By D. W. GOULD

The calorific value of the lighter hydrocarbons is most readily determined at constant pressure, and, except where a high degree of accuracy is necessary, neither the apparatus nor the manipulative skill are beyond the means of most technical laboratories

Kharasch [2, 1929] has made an excellent review and presentation of data upon the heats of combustion of many hydrocarbons, and for most practical purposes, the values assigned by him may be accepted as correct. The author lists about 170 compounds with a sufficient number in each group that interpolation or extension to new or unusual hydrocarbons is made easily

An arbitrary definition is made in this study whereby all compounds boiling at and below a temperature of 69° C (156° F) and 760 mm Hg are called gases. For data on higher boiling hydrocarbons reference should be made to another section in which the principal properties of individual compounds are summarized. Where more recent

work seems to justify it, substitution has been made for Kharasch's data. That author expresses results for heats of combustion at 18° C, whereas Rossum [3, 4, 5, 1934] uses the more common temperature of 25° C. Where Kharasch's data is used in this presentation, a correction to 25° C has been made. This correction is expressed by application of the following

$$C_nH_m + \left(n + \frac{m}{4}\right)O_2 \rightarrow (n)CO_2 + \left(\frac{m}{2}\right)H_2O - \Delta H$$

If $-\Delta H_{25}$ represents the heat of combustion at 25° C

and $-\Delta H_{\theta}$ represents the heat of combustion at θ° C

$$\text{Then } -\Delta H_{\theta} = -\Delta H_{25} + (\theta - 25) \left[n C_{p(CO_2, g, \theta)} + \frac{m}{2} C_{p(H_2O, liquid, \theta)} - \left(n + \frac{m}{4}\right) C_{p(O_2, g, \theta)} - C_{p(C_nH_m, g, \theta)} \right]$$

Values of Heat capacity, C_p , used are stated below in terms of gram-calories per degree per gram-mole

TABLE I
Heats of Combustion of Hydrocarbon Gases

1	2	3	4	5	6	7	8
Formula	Name	Molecular weight	Kg cal per g mole	B Th U per lb mole	Kg cal per cu metre (at 0° C, 760 mm)	B Th U per cu ft (60° F, 29.9 in Hg)	References
<i>(Saturated hydrocarbons (aliphatic))</i>							
C ₁ H ₄	Methane	16 03	212.79 ± 0.07	383,020	9,494	1,011	3
C ₂ H ₆	Ethane	30 05	372.81 ± 0.11	671,060	16,634	1,770	3
C ₃ H ₈	Propane	44 06	530.57 ± 0.12	955,030	23,673	2,520	3
C ₄ H ₁₀	Normal butane	58 08	687.94 ± 0.15	1,238,290	30,695	3,267	3
C ₄ H ₁₀	Isobutane	58 08	686.31 ± 0.13	1,235,360	30,622	3,259	4
C ₅ H ₁₂	Normal pentane	72 09	845.27 ± 0.21	1,521,490	37,714	4,014	3
<i>(Aliphatic-ethylene)</i>							
C ₂ H ₄	Ethylene	28 03	337.28 ± 0.07	607,100	15,049	1,602	5
C ₃ H ₆	Propylene	42 05	490 0	882,000	21,863	2,327	2
C ₄ H ₈	Butylene	56 06	646.9	1,164,420	28,863	3,072	2
C ₄ H ₈	Amylene	70 08	803.4	1,446,120	35,846	3,816	2
C ₅ H ₁₀	Trimethylethylene	70 08	803.2	1,445,760	35,837	3,815	2
C ₆ H ₁₀	Hexylene	84 09	952.1	1,713,780	42,481	4,522	2
C ₆ H ₁₀	Diallyl	82 08	915.7	1,648,260	40,857	4,349	2
<i>(Polymethylenes)</i>							
C ₃ H ₆	Trimethylene	42 05	496.6	893,880	22,157	2,359	2
C ₄ H ₈	Methylcyclobutane	70 08	783.8	1,410,840	34,972	3,723	2
C ₅ H ₁₀	Cyclopentane	70 08	783.2	1,409,760	34,945	3,720	2
C ₆ H ₁₂	Methylcyclopentane	84 09	937.4	1,687,320	41,825	4,452	2
C ₆ H ₁₂	Cyclohexane	84 09	937.5	1,687,500	41,829	4,453	2
C ₆ H ₁₂	Bicyclohexane (0,1,3)	82 08	912.1	1,641,780	40,696	4,332	2
<i>(Acetylene hydrocarbons)</i>							
C ₂ H ₂	Acetylene	26 02	311.9	561,420	13,916	1,481	2
C ₃ H ₄	Allylene	40 03	468.9	844,020	20,921	2,227	2

Values in column 5 = $1.8 \times 1000 \times \text{kg cal per g mole}$

Values in column 6 = $\frac{1000}{22.412} \times \text{kg cal per g mole}$

Values in column 7 = $1000 \times 1.8 \times \frac{1}{\left(359 \times \frac{460+60}{460+32}\right)} \times \text{kg cal per g mole}$

CO₂ (gas) = 8.8, H₂O (liquid) = 18.0, O₂ (gas) = 7.0.
 The heat capacity of hydrocarbons is estimated by the
 equation of Cope, Lewis, and Weber [1, 1931]

$$C_{p(C_nH_m, gas)} = 1.826 + 1.587_n + 1.267_m$$

Table 1 shows the gross or higher calorific values for
 hydrocarbon gases expressed as kilogram calories per
 gram mole, and as derived units of sufficient accuracy for
 most engineering uses

REFERENCES

- 1 COPE, J. Q., LEWIS, W. K., and WEBER, H. C. *Ind Eng Chem* **23**, 887 (1931)
- 2 KHARABACH, M. S. *Bur Stand J Res* **2**, 359 (1929)
- 3 ROSSINI, F. D. *Bur Stand J Res* **13**, 23 (1934)
- 4 ROSSINI, F. D. *Bur Stand J Res* **15**, 357 (1935)
- 5 ROSSINI, F. D., and KNOWLTON, J. W. Unpublished data of the National Bureau of Standards. See also *Bur Stand J Res* **17**, 629 (1936)

COMBUSTION DATA FOR GASEOUS FUELS

By E. S. L. BEALE, M.A., F.Inst.P., *Consultant in Engineering Physics, London,* and
P. DOCKSEY, B.A., *Anglo-Iranian Oil Company*

In the following article some of the data more commonly required in calculations on the combustion of gaseous fuels is given in a convenient form for practical use. All the data is available in various publications but not always in a convenient form. The main tables in this article are arranged on the same lines as those given in *Technical Data on Fuel*, and more recent data has been added where available.

Calorific Values of Gases and Vapours

The calorific values of the more common constituents of fuel gases are given in Table I per unit mass, per unit volume, and per mole under some of the more usual conditions of measurement, both gross and net values. All these figures have been calculated from the data given in the last column, namely, the heat of combustion (gross) kg cal/s per gramme mole of the pure compound at constant pressure (1 atm.) in terms of the 15° Calorie.

With a few exceptions mentioned below, the whole of this data is that given by Rossini [8, 1931, 9, 10, 1934, 11, 1935, 12, 1936], and refers to the heat of combustion at 25° C. The figure for H₂S is that given by Spiers [13, 1935]. In the case of iso-butylene, trimethyl ethylene, benzene and toluene, the data given by Kharasch [6, 1929] has been used, but as it is not quite clear exactly to what temperature this data refers, no attempt has been made to correct the data to 25° C. This correction amounts usually to less than 0.1% for a range of 10° C, so that the fact that the heats of combustion are used for combustion calculations at a different temperature than that for which they were determined, e.g. 60° F, is of no significance in practical work. In calculating Table I no allowance has been made for this effect.

The only effect of temperature which has been allowed for is in the calculation of the volume of the gas. For this

purpose it has been assumed that the gas laws hold in all cases and that 1 gram molecule occupies 22.412 litres at 0° C and 760 mm (1 lb molecule = 378.44 cu ft. at 60° F and 30 in.)

In the case of 'wet' gases it is assumed that the gas is saturated with water vapour at the temperature stated, namely 60° F, and that the vapour pressure of water at this temperature is 0.522 in. of mercury and that the water vapour also obeys the gas laws.

The net calorific values have been derived from the corresponding gross values by subtracting the latent heat of the water formed by the combustion of the hydrogen in the fuel in all cases. This has been reckoned at 586 g. cal. per gram or 1,055 B Th U per lb, which is the value recommended by the Heat Engine Trials Committee of the Institute of Civil Engineers and corresponds to the latent heat of steam at 60° F. At 0° C, the latent heat differs from this value by about 8.5 g. cal. per gram, which would represent a change in the calculated net calorific value of only about 0.1% for Methane which is small enough to be ignored.

In calculating the specific gravity of the gases, the molecular weight of air has been taken to be 28.97.

A convenient practical means of estimating the calorific value of mixtures of normal paraffins, H₂S and water vapour from the specific gravity of the mixture, is given in the following equation which is based on the same data as Table I:

$$C = 1,563 G + 140 - 14.4X - 11.13Y,$$

where C = gross calorific value, B Th U per cu ft at 60° F and 30 in. Hg

G = specific gravity of gas mixture rel. air

X = % H₂S by volume

Y = % water vapour by volume

TABLE I

Gas or vapour	Formula	Mol wt	Sp. gr. rel. air (dry)	Calorific values												kg cal/s per mole at 25° C
				Cal. per g				Cal. per l				B Th U per lb				
				At 0° C and 760 mm (dry)				At 60° F and 30 in. mercury				B Th U per cu ft				
				Gross		Net		Gross		Net		Gross		Net		
Hydrogen	H ₂	2.016	0.0696	33,885	28,647	60,993	52,660	51,565	44,520	324.9	319.3	274.7	270.0	68.313		
Methane	CH ₄	16.03	0.5533	13,274	11,937	9,494	8,552	23,893	23,427	21,523	21,103	1,012.1	994.5	911.7	893.8	212.79
Ethane	C ₂ H ₆	30.05	1.0573	12,406	11,352	16,554	15,221	22,871	20,434	20,219	1,772.2	1,745.3	1,622.9	1,594.3	372.81	
Propane	C ₃ H ₈	44.06	1.5209	12,042	11,084	23,673	21,789	21,530	19,951	19,808	2,523.3	2,479.6	2,322.6	2,282.2	530.57	
n-Butane	C ₄ H ₁₀	58.08	2.0048	11,845	10,936	30,895	28,340	21,321	21,204	19,685	19,577	3,272.0	3,215.1	3,020.9	2,968.4	687.94
i-Butane	C ₄ H ₁₀	58.08	2.0048	11,817	10,908	30,622	28,267	21,271	21,155	19,634	19,527	3,264.2	3,212.1	3,015.1	2,965.4	686.31
Pentane	C ₅ H ₁₂	72.09	2.4894	11,725	10,846	37,715	34,809	21,185	21,012	19,523	19,437	4,020.3	3,950.4	3,719.0	3,654.3	845.27
Hexane	C ₆ H ₁₄	86.11	2.9723	11,651	10,783	44,726	41,429	20,954	20,868	19,469	19,337	4,767.6	4,684.7	4,416.0	4,339.3	1,002.40
Ethylene	C ₂ H ₄	28.03	0.9676	12,033	11,280	15,049	14,107	21,639	21,415	20,304	20,076	1,604.2	1,576.3	1,503.8	1,477.6	337.28
Propylene	C ₃ H ₆	42.03	1.4515	11,623	10,900	21,863	20,450	22,975	20,817	19,630	19,472	2,330.6	2,290.3	2,179.9	2,142.0	480.0
i-Butylene	C ₄ H ₈	56.06	1.9351	11,543	10,792	28,877	26,993	20,781	20,563	19,326	19,172	3,072.2	3,024.7	2,877.3	2,827.3	647.2
Tri-methyl-ethylene	C ₄ H ₈	70.08	2.4190	11,467	10,714	35,856	33,501	20,641	20,547	19,285	19,197	3,822.1	3,755.6	3,571.0	3,508.9	803.6
Benzene	C ₆ H ₆	78.05	2.6941	10,046	9,680	35,124	33,711	18,155	18,081	17,624	17,353	3,744.1	3,679.0	3,393.4	3,351.0	787.2
Toluene	C ₇ H ₈	92.06	3.1777	10,288	9,789	42,093	40,209	18,446	18,382	17,620	17,359	4,487.0	4,409.0	4,286.1	4,211.6	943.4
Carbon monoxide	CO	28.0	0.9665	2,415.1	2,415.1	3,017	3,017	4,347	4,298	4,347	4,298	321.63	316.04	321.63	316.04	67.623
Methyl alcohol	CH ₃ O	32.03	1.1056	5,700.3	5,041.3	8,147	7,205	10,261	10,160	9,074	8,985	868.4	853.3	768.0	754.6	182.58
Ethyl alcohol	C ₂ H ₅ O	46.05	1.5896	7,313.3	6,625.3	15,027	13,614	13,164	13,073	11,926	11,844	1,801.8	1,773.9	1,451.1	1,425.9	336.78
Hydrogen sulphide	H ₂ S	34.08	1.1764	3,954.2	3,644	6,013	5,542	7,118	7,052	6,539	6,498	640.9	629.8	590.7	580.9	134.76

Fig. 1 shows the approximate gross calorific value of hydrocarbon gases, paraffins and olefins, plotted against the specific gravity relative to air with a line drawn halfway between the two curves to represent cracked gases which often consist of about 50% by volume of unsaturated

in calculating all volumes, exactly as explained for Table I, so that the two tables are strictly comparable. The composition of air has been taken to be 21.00% by volume of oxygen

While in many cases the departure of fuel gases from the

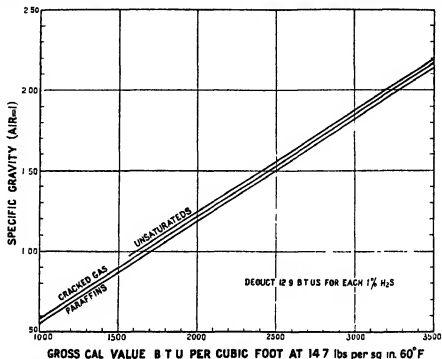

FIG 1 Calorific value of gases (gross)

Gaseous Volumes

The volumes of the gases concerned in the combustion of those in Table I have been calculated and are shown in Table II. In this table also, the gas laws have been assumed

gas laws can be ignored owing to the small proportions in which the heavier constituents are present, this is not the case with some gases which are burnt in the refinery. Full details of the deviation of these gases from the gas laws would be outside the scope of the present article, but an

TABLE II

Gas or vapour	Formula	Sp gr rel air	% deviation from gas laws 100% at 0° C and 760 mm Dry	g per l 760 mm Dry	Weight per unit volume		Combustion requirements		Combustion products				Total (wet)	
					lb per cu ft, 60° F., 30 in. Hg.	Saturated (including the water)	Volts per unit vol = mols per mols		Total (dry)					
							Dry	O ₂	Air	CO ₂	H ₂ O	N ₂		
Oxygen	O ₂	1.1044	+0.09	1.428	0.08457	0.08310	0.08393							
Nitrogen (pure)	N ₂	0.9669	+0.05	1.250	0.07406	0.07275	0.07338							
Nitrogen (atmospheric)		0.9723		1.257	0.07446	0.07317	0.07400							
Air		1.0000	+0.06	1.293	0.07657	0.07524	0.07607							
Carbon dioxide	CO ₂	1.5185	+0.71	1.963	0.11628	0.11426	0.11509							
Water vapour	H ₂ O	0.6218		0.804			0.04761							
Hydrogen	H ₂	0.0696	-0.02	0.0899	0.005327	0.005234	0.006064	0.5	2.381		1.0	1.881	1.881	2.881
Methane	CH ₄	0.5533	+0.23	0.7152	0.04236	0.04162	0.04245	2.0	9.524	1.0	2.0	7.524	8.524	10.524
Ethane	C ₂ H ₆	1.0373	+1.16	1.3608	0.07940	0.07802	0.07885	3.5	16.667	2.0	3.0	13.167	15.167	18.167
Propane	C ₃ H ₈	1.5209	+2.68	1.9659	0.11642	0.11460	0.11523	5.0	23.810	3.0	4.0	18.810	21.810	25.810
n-Butane	C ₄ H ₁₀	2.0048		2.5914	0.15347	0.15080	0.15163	6.5	30.952	4.0	5.0	24.452	28.452	33.452
i-Butane	C ₄ H ₁₀	2.0048		2.5914	0.15347	0.15080	0.15163	6.5	30.952	4.0	5.0	24.452	28.452	33.452
Pentane	C ₅ H ₁₂	2.4884		3.1719	0.19040	0.18717	0.18800	8.0	38.095	5.0	6.0	30.095	35.095	41.095
Hexane	C ₆ H ₁₄	2.9723		3.8421	0.22754	0.22358	0.22441	9.5	45.238	6.0	7.0	37.238	41.738	48.738
Heptane	C ₇ H ₁₆	0.9676	+0.77	1.2506	0.07407	0.07278	0.07361	3.0	14.286	2.0	2.0	11.286	13.286	15.286
Propylene	C ₃ H ₆	1.4515		1.8762	0.11111	0.10918	0.11001	4.5	21.429	3.0	3.0	16.929	19.929	22.929
Butylene	C ₄ H ₈	1.9351		2.5013	0.14813	0.14555	0.14638	6.0	28.571	4.0	4.0	22.571	26.571	30.571
Pentylene	C ₅ H ₁₀	2.4190		3.1268	0.18518	0.18196	0.18279	7.5	35.714	5.0	5.0	28.214	33.214	38.214
Hexene	C ₆ H ₁₀	2.6941		3.4825	0.20624	0.20265	0.20348	7.5	35.714	6.0	6.0	28.214	34.214	37.214
Toluene	C ₇ H ₈	3.1777		4.0775	0.24326	0.23897	0.23980	9.0	42.857	7.0	4.0	33.857	40.857	46.857
Carbon monoxide	CO	0.9665	+0.03	1.2493	0.07395	0.07270	0.07353	0.5	2.381	1.0	1.0	1.881	2.881	3.881
Methyl alcohol	CH ₃ O	1.1096		1.4291	0.08464	0.08316	0.08399	2.0	9.524	1.0	2.0	7.524	8.524	10.524
Ethyl alcohol	C ₂ H ₅ O	1.3096		2.0547	0.12168	0.11954	0.12039	3.5	16.667	2.0	3.0	13.167	15.167	18.167
Hydrogen sulphide	H ₂ S	1.1764	+1.2	1.5206	0.09005	0.08849	0.08932	1.5	7.143	1.0	1.0	5.643	6.643	7.643

indication of the magnitude of this effect is given in column 4 of Table II. In this column is given the value of 100 λ from the data in the International Critical Tables at 0° C and 760 mm.

If P_1, V_1 represent the pressure and volume of a given quantity of gas at 1 atmosphere and 0° C, and P_0, V_0 represent the pressure and volume that the same quantity of gas at the same temperature would occupy if the gas laws applied, then λ is defined as follows

$$\frac{P_0 V_0}{P_1 V_1} = 1 + \lambda$$

Therefore, 100 λ is the percentage reduction in volume of the gas at 0° C and 760 mm below that calculated from the gas laws. The value of 100 λ changes considerably with temperature in the case of the heavier gases, so that the figures given must only be taken as a guide. For example, in the case of propane, the value changes from +2.68% at 0° C to about +2.2% at 15.5° C (60° F).

Specific Heat Data

In the following tables are given specific heats of the more common gases and vapours. These tables are either taken from or derived from the tables given in *Technical Data on Fuel* [13, 1935]. All figures given are theoretical values calculated from the spectroscopic characteristics of the gases which are now believed to be more reliable than the data derived from direct experiment. It will be noticed that the first differences are not quite regular in these tables due to jumps in the atomic states, but the irregularities are not great enough to make interpolation unreliable.

The specific heat at constant pressure varies somewhat with the pressure. The tabulated values relate to atmo-

spheric pressure but are sufficiently accurate for all pressures up to about 10 atmospheres.

The experimental data on the specific heat of Hydrogen Sulphide is very meagre and no reliable indication of the change of specific heat with temperature above 15° C can be obtained. The evidence points to a comparatively small temperature coefficient, so that it is suggested that, in the absence of proper data, the specific heat of H₂S should be taken as 0.25 g cal per gram °C and made independent of temperature.

To convert the specific heats given in Tables III and IV to other units, the figures should be multiplied by the factors given in Table V.

Dissociation

Carbon dioxide and water vapour become partially dissociated at high temperatures, thereby limiting the maximum attainable flame temperature. The following formulae and Table VI have been calculated by Spiers [13, 1934] from the data of Goodenough and Felbeck [4, 1924]. In these two formulae the temperature T is expressed in degrees Kelvin.

Carbon Dioxide Equilibrium (applicable to temperatures above 1600° K.)

$$4.571 \log K_{\text{CO}_2} = \frac{69894.4}{T} + 4.1470 \log T + 0.378 \times 10^{-4} T - 0.0972 \times 10^{-4} T^2 - 36.04838$$

Water Vapour Equilibrium (applicable to all temperatures)

$$4.571 \log K_{\text{H}_2\text{O}} = \frac{57111.1}{T} - 2.6135 \log T - 0.84834 \times 10^{-4} T + 0.19602 \times 10^{-4} T^2 - 2.96716.$$

TABLE III

True Specific Heats at constant pressure for undissociated gases

g cal per g °C or B Th U per lb °F

t° C	O ₂	N ₂	Air	H ₂ O vapour	CO ₂	CO	H ₂	CH ₄	C ₂ H ₆	C ₂ H ₄	C ₂ H ₂
0	0.218	0.248	0.240	0.443	0.195	0.249	3.40	0.496	0.397	0.342	0.266
100	0.223	0.248	0.241	0.449	0.220	0.250	3.46	0.591	0.502	0.431	0.333
200	0.230	0.251	0.245	0.462	0.238	0.253	3.47	0.681	0.599	0.514	0.400
300	0.238	0.254	0.250	0.475	0.255	0.258	3.48	0.765	0.688	0.586	0.462
400	0.245	0.259	0.255	0.490	0.268	0.264	3.49	0.844	0.769	0.650	0.528
500	0.251	0.265	0.261	0.506	0.278	0.270	3.50	0.918	0.842	0.706	0.587
600	0.256	0.271	0.266	0.522	0.287	0.277	3.54	0.987	0.908	0.754	0.642
700	0.260	0.276	0.271	0.540	0.294	0.282	3.57	1.050	0.965	0.793	0.692
800	0.263	0.281	0.276	0.556	0.300	0.286	3.61	1.109	1.015	0.823	0.738
900	0.265	0.285	0.279	0.572	0.304	0.291	3.66	1.162	1.056	0.845	0.768
1,000	0.269	0.289	0.283	0.587	0.309	0.294	3.71	1.209	1.089	0.858	0.788
1,100	0.270	0.293	0.286	0.602	0.312	0.298	3.77				
1,200	0.273	0.295	0.288	0.615	0.315	0.300	3.81				
1,300	0.274	0.298	0.291	0.628	0.318	0.302	3.87				
1,400	0.276	0.300	0.293	0.639	0.320	0.305	3.91				
1,500	0.278	0.302	0.295	0.649	0.321	0.306	3.96				
1,600	0.280	0.303	0.296	0.659	0.323	0.308	4.01				
1,700	0.281	0.305	0.298	0.668	0.324	0.309	4.05				
1,800	0.283	0.306	0.299	0.677	0.325	0.310	4.09				
1,900	0.286	0.307	0.301	0.684	0.327	0.311	4.13				
2,000	0.287	0.309	0.302	0.692	0.327	0.312	4.16				
2,100	0.288	0.310	0.304	0.698	0.328	0.314	4.19				
2,200	0.290	0.311	0.305	0.704	0.329	0.314	4.23				
2,300	0.292	0.312	0.305	0.709	0.330	0.315	4.25				
2,400	0.293	0.313	0.307	0.714	0.330	0.316	4.28				
2,500	0.295	0.314	0.308	0.719	0.331	0.317	4.30				
2,600	0.296	0.314	0.308	0.723	0.331	0.318	4.34				
2,700	0.297	0.314	0.309	0.726	0.332	0.318	4.36				
2,800	0.298	0.315	0.310	0.729	0.332	0.318	4.38				
2,900	0.300	0.316	0.311	0.731	0.332	0.318	4.40				
3,000	0.300	0.316	0.311	0.734	0.333	0.318	4.43				

TABLE IV

Mean Specific Heats at constant pressure between 0° and t° C for undissociated gases
g cal per g °C or B Th U per lb °F

t° C	O ₂	N ₂	Air	H ₂ O vapour	CO ₂	CO	H ₂	CH ₄	C ₂ H ₂	C ₂ H ₄	C ₂ H ₆
0	0.218	0.248	0.240	0.443	0.195	0.249	3.40	0.496	0.397	0.342	0.266
100	0.221	0.248	0.240	0.445	0.208	0.249	3.44	0.545	0.450	0.388	0.300
200	0.223	0.248	0.242	0.450	0.219	0.250	3.45	0.590	0.501	0.431	0.333
300	0.227	0.250	0.243	0.457	0.229	0.252	3.46	0.635	0.548	0.471	0.366
400	0.230	0.252	0.246	0.463	0.236	0.254	3.46	0.677	0.594	0.507	0.398
500	0.234	0.254	0.248	0.470	0.244	0.257	3.47	0.719	0.636	0.542	
600	0.237	0.256	0.250	0.478	0.250	0.259	3.48	0.758	0.676	0.578	
700	0.240	0.258	0.254	0.485	0.256	0.262	3.49	0.794	0.713	0.602	
800	0.243	0.261	0.256	0.494	0.261	0.266	3.50	0.830	0.748	0.628	
900	0.245	0.263	0.258	0.501	0.266	0.268	3.51	0.864	0.780	0.651	
1,000	0.247	0.266	0.261	0.510	0.270	0.270	3.54	0.896	0.809	0.671	
1,100	0.249	0.268	0.263	0.518	0.274	0.273	3.55				
1,200	0.251	0.271	0.265	0.525	0.277	0.275	3.57				
1,300	0.253	0.272	0.267	0.531	0.280	0.277	3.59				
1,400	0.255	0.275	0.268	0.540	0.283	0.278	3.61				
1,500	0.256	0.276	0.271	0.546	0.285	0.280	3.64				
1,600	0.258	0.278	0.272	0.552	0.288	0.282	3.65				
1,700	0.258	0.279	0.273	0.560	0.290	0.283	3.67				
1,800	0.260	0.281	0.274	0.566	0.292	0.285	3.69				
1,900	0.262	0.282	0.276	0.572	0.293	0.286	3.71				
2,000	0.263	0.283	0.277	0.577	0.295	0.287	3.74				
2,100	0.264	0.284	0.278	0.583	0.297	0.289	3.76				
2,200	0.265	0.286	0.279	0.588	0.298	0.290	3.78				
2,300	0.266	0.287	0.280	0.595	0.300	0.291	3.80				
2,400	0.267	0.287	0.281	0.598	0.301	0.292	3.83				
2,500	0.268	0.289	0.282	0.603	0.302	0.293	3.84				
2,600	0.269	0.291	0.283	0.608	0.303	0.294	3.86				
2,700	0.270	0.291	0.284	0.612	0.304	0.295	3.87				
2,800	0.271	0.292	0.285	0.617	0.305	0.295	3.89				
2,900	0.272	0.293	0.285	0.621	0.306	0.296	3.91				
3,000	0.274	0.294	0.286	0.623	0.307	0.297	3.93				

TABLE V

Conversion Factors from g cal per g °C to other units

From g cal per g °C to	O ₂	N ₂	Air	H ₂ O	CO ₂	CO	H ₂	CH ₄	C ₂ H ₂	C ₂ H ₄	C ₂ H ₆
g cal per litre °C at 0° C and 760 mm	1.428	1.250	1.293	0.804	1.963	1.249	0.0899	0.715	1.341	1.251	3.483
g cal per g mol °C or B Th U per lb mol °F	32.00	28.02	28.97	18.02	44.00	28.00	2.016	16.03	30.05	28.03	78.05
B Th U per cu ft °F at 0° C and 760 mm	0.0891	0.0780	0.0807	0.0502	0.1226	0.0780	0.00562	0.0447	0.0837	0.0781	0.2174
B Th U per cu ft °F at 60° F and 30 in	0.0846	0.0740	0.0765	0.0476	0.1163	0.0740	0.00533	0.0424	0.0794	0.0741	0.2062

TABLE VI

Temp °C	Carbon dioxide						Water vapour					
	K _{CO₂}	% dissociated when pressure in atmospheres =				K _{H₂O}	% dissociated when pressure in atmospheres =					
		1	0.5	0.2	0.1		1	0.5	0.2	0.1		
1,400	18,060	0.2	0.25	0.37	0.4	61,030	0.08	0.10	0.14	0.17		
1,500	5,820	0.4	0.5	0.73	0.85	22,260	0.15	0.20	0.3	0.35		
1,600	2,120	0.8	1.0	1.3	1.6	9,007	0.3	0.4	0.5	0.6		
1,700	858.4	1.5	1.8	2.4	3.0	3,595	0.5	0.6	0.8	1.0		
1,800	379.2	2.5	3.0	4.0	5.0	1,916	0.8	1.0	1.4	1.8		
1,900	180.8	3.9	4.9	6.5	8.1	984.0	1.2	1.6	2.2	2.7		
2,000	92.08	6.0	7.5	10.0	12.4	536.1	1.9	2.4	3.3	4.0		
2,100	49.67	8.9	11.1	14.7	18.1	307.8	2.8	3.4	4.7	5.8		
2,200	28.16	12.7	15.7	20.6	25.2	185.1	3.8	4.8	6.5	8.0		
2,300	16.69	17.5	21.4	27.8	35.4	116.0	5.1	6.4	8.7	10.8		
2,400	10.29	23.2	28.1	35.8	42.4	75.32	6.6	8.5	11.4	14.1		
2,500	6.565	29.8	35.7	44.4	51.5	50.58	8.8	10.9	14.6	17.9		
2,600	4.321	37.0	43.7	53.1	60.3	35.00	11.1	13.8	18.1	22.2		
2,700	2.923	44.5	51.7	61.2	68.2	24.87	13.7	16.9	22.2	27.0		
2,800	2.028	52.0	59.3	68.6	74.9	18.11	16.6	20.4	26.5	32.0		
2,900	1.438	59.3	66.3	74.9	80.5	13.50	19.8	24.2	31.1	37.2		

In Table VI the equilibrium constants and percentage dissociated are given for CO₂ and steam at various temperatures in degrees Centigrade. It should be noted that the equilibrium constants hold good for mixtures as well as for the pure gases. The value for the water-gas equilibrium constant $K_{\text{H}_2\text{O}}$ at any temperature is obtained by dividing $K_{\text{H}_2\text{O}}$ by K_{CO} .

A considerable amount of information on dissociation and equilibrium constants is given in a convenient form in *Technical Data on Fuel*, which also contains a graphical method of calculating flame temperatures due to A. J. V. Underwood based on the data given by Goodenough and Felbeck (loc cit).

Self-Ignition Temperature in Air

The self-ignition temperature of fuels, its determination in the laboratory and its relation to the behaviour in internal combustion engines, is dealt with in another article. The ignition temperature is influenced to a very great extent by the experimental conditions, type of contact surface, &c [3, 1927, 7, 1927, 1928, 1929].

The results given in the following Table VII were taken from Haslam and Russel (Fuels and their Combustion) and refer to ignition in air at atmospheric pressure when the fuel and air were heated in two independent streams and then mixed. These figures are quoted as a guide to the relative self-ignition temperatures of these vapours at atmospheric pressure only.

TABLE VII

Self-ignition Temperature in Air at Atmospheric Pressure

	°C
Hydrogen	580-590
Carbon monoxide	644-658
Methane	650-750
Ethane	520-650
Ethylene	542-547
Benzene	740
Toluene	810
Ethyl alcohol	558

In the case of preliminary products the SIT in air is not usually determined but its value lies as a rule between 50° and 100° C higher than its value in oxygen [1, 1932]. The figures obtained in both cases depend to a great extent on the experimental conditions and also of course on the chemical constitution. Approximate values for the SIT in air are as follows:

	°C
Gasoline fraction, e.g. [14, 1934]	450-500
Gas oil	400-450
Refined wax	350-400

A familiar example of the low SIT of refined wax is to be seen in the vapour from wax heated to near its boiling point in an open dish, which will ignite spontaneously some time after the source of heat has been removed.

Limits of Inflammability

The approximate limits of inflammability of gases and vapours in air at ordinary temperatures and atmospheric pressure is given in the following Table VIII.

The figures were taken from Coward and Jones [2, 1929] and refer to upward propagation in stagnant gas mixture in large open vessels, the figures in italics represent experiments with mixtures contained in closed or small vessels and are applicable only approximately to conditions in

which normal pressure is maintained during the passage of the flame.

As is to be expected, the limits of inflammability are extended at each end as the initial temperature is increased and greatly reduced as the oxygen content of the atmosphere is reduced. With downward propagation of flame

TABLE VIII

Gas or vapour	% by vol	
	Lower limit	Upper limit
Acetylene	3.0	
Benzene	1.4	7
Benzene*	1.1	
Butane	1.9	8.5
Carbon monoxide	12.5	74
Coal gas*	5.3	31
Cyclohexane	1.3	8.3
Ethane	3.2	12.5
Ethylene	3.0	29
Ethylene oxide	1.0	80
Furfural (125° C)	2	
Gasoline*	1.4	6
Hydrogen	4.1	74
Hydrogen sulphide	4.7	46
Methane	5.3	14.0
Methyl alcohol	7	
Methyl cyclo-hexane	1.2	
Natural gas*	4.8	13.5
Pentane	1.5	7.5
Propane	2.4	9.5
Toluene	1.4	7
Water gas*	6 to 9	55 to 70

* The figures vary with composition.

the lower limit is slightly higher and the upper limit much lower than for upward propagation as given in the table.

Le Chatelier's rule for the limiting composition of mixtures of combustible gases in air is

$$L = \frac{a+b+c}{\frac{a}{A} + \frac{b}{B} + \frac{c}{C}}$$

where a , b , c are the relative proportions of the several combustible gases present and A , B , C their inflammability limits, respectively. This rule applies more accurately to the lower limit mixtures than to the upper limit mixtures.

A method of calculating the inflammability limits of complex mixtures of gases is given by Jones [5, 1931]. The following abstract of the method is given by Spiers [13, 1935, p. 243].

The procedure is as follows:

- 1 The composition of the mixture is first recalculated on an air-free basis.
- 2 An arbitrary dissection of the air-free mixture is made into simpler mixtures, each of which contains only one inflammable gas and part or all of the nitrogen or carbon dioxide. Some discrimination is needed to choose appropriate quantities, but a fair latitude of choice is usually open.
- 3 The limits of each mixture thus dissected are read from the curves in Figure 2.
- 4 The limits of the air-free mixture are calculated from the figures for the dissected mixture by means of Le Chatelier's rule.

5 From the limits of the air-free mixture thus obtained the limits of the original complex mixture are deduced.

Notes. If the amount of inert gases is so great that a

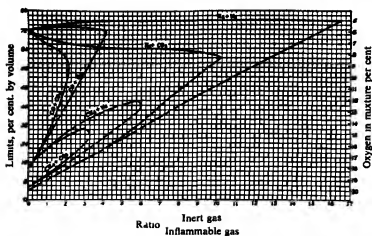

FIG 2 Limits of inflammability of hydrogen, carbon monoxide, and methane containing various amounts of carbon dioxide and nitrogen (Reproduced by permission from *Technical Data on Fuel*, edited by H M Spiers)

complete series of inflammable mixtures cannot be dissected, the air-free mixture is not inflammable. Moreover, the air-free mixture may be inflammable, but when its limits are multiplied by the appropriate factor in the final stage of the calculation the result may be greater than 100 for each limit, the original mixture is then not capable of forming an explosive mixture with air because it contains too much air already. Finally, should the lower limit of the original mixture be less than 100 and the higher limit greater than 100, the mixture is inflammable *per se* and would explode if a source of ignition were present.

In the case of mixtures of coal gas and blue water gas, e.g. gas from vertical retorts, as the calorific value decreases and hence the content of water gas increases, the concentration of gas in the lower limit mixture increases very slightly, but the concentration of gas in the upper limit mixture increases rapidly and to a successively greater extent as the content of water gas is increased.

REFERENCES

- 1 CHALOUER, J L *J I P T* 18, 548 (1932)
- 2 COWARD, H F, and JONES, G W *U S Bur Mines Bull* 279 (1929)
- 3 EDGERTON, A, and GATES, G F *J I P T* 13, 244, 257, 273, 281 (1927)
- 4 GOODENOUGH, G A, and FALBECK, G T *Bulletin 139, Engineering Experimental Station, University of Illinois* (1924)
- 5 JONES, G W *U S Bur Mines Tech Paper* no 450 (1931)
- 6 KHARASCH, M S *Bur Stand J Res* 2, 359 (1929)
- 7 MASSON H J, and HAMILTON, W F *Ind Eng Chem* 19, 1335 (1927), 20, 813 (1928), 21, 544 (1929)
- 8 ROSSINI, F D *Bur Stand J Res* 6, 1, 35 (1931)
- 9 ——— *Bur Stand J Res* 12, 735 (1934)
- 10 ——— *Bur Stand J Res* 13, 23 (1934)
- 11 ——— *Bur Stand J Res* 15, 357 (1935)
- 12 ——— *Bur Stand J Res* 17, 629 (1936)
- 13 SPIERS, H M *Technical Data on Fuel*, 4th edition (1935)
- 14 TOWNSEND, D T A, and COHEN L L *Chem and Ind* 153, 267 (1934)

SELECTED BIBLIOGRAPHY

- BONE and TOWNEND *Flame and Combustion in Gases* (Longmans Green, 1927)

SPECIFIC HEAT AND HEAT CONTENT OF PETROLEUM PRODUCTS

By D. W. GOULD

Specific Heat of Petroleum Oils

The determination of the specific heat of liquid petroleum products requires extensive equipment and a high degree of manipulative skill to exclude conditions involving errors of considerable magnitude. Improper methods will fail to account for calorimetric errors or for the fact that a change of state has taken place or even a change in composition (cracking).

It is believed that the summary of data as given by Cragoe [2, 1929] is a fair average for the majority of oils and can be used with confidence in engineering calculations. It is observed that little experimental work has been done upon oils with density less than 0.7, probably because of the difficulty in excluding or accurately accounting for

Specific Heats of Cracked Products

The data on the specific heats of cracked products is meagre. Gary, Ruben, and Ward [3, 1932], carried out experiments on three cracked gas oils, the range in specific gravity being 887 to 944. Of these, the heaviest contained no raw stock, while the lightest consisted of one part of raw stock to 1.93 parts of recycle oil, and the intermediate sample contained 1 part of raw stock to 3.34 parts of recycle. All were derived from Mid-Continent crude. The results of the experiments were expressed in the form of an equation which showed the effect of specific gravity and temperature upon specific heat. Since the proportion of raw stock will also probably have an effect on the specific heat which is not taken into account by the equation, it

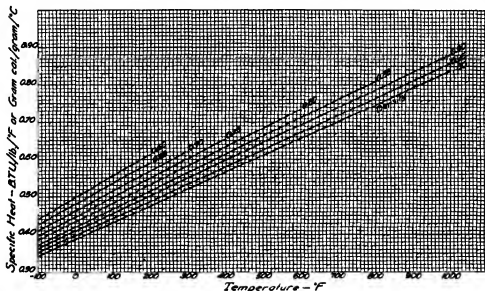

FIG. 1 True specific heat of petroleum liquids

vaporization. The equation for the true specific heat at atmospheric pressure in B Th U per pound per °F or in calories per gram per °C at °F is as follows:

$$C = \frac{1}{\sqrt{S}} (0.388 + 0.00045t),$$

where S = specific gravity at 60°/60° F
and t = temperature in °F

Calculated values from this equation for the density (20°/4° C) range from 0.6 to 1.0 and for temperatures from -100° to 1,000° F are tabulated in Table 1, and also shown in Fig. 1.

The tabulated values may be regarded as accurate to within about 5% for the majority of oils, but a large number of investigations on the thermal properties of petroleum products [5] makes it certain that oils from different sources differ substantially both as regards the specific heat of oils of the same density at 60° F say, and also as regards the change in their specific heat with temperature, see, for instance [7, 1930]

would not be safe to use the equation for extrapolation far out of the range of specific gravities covered by the experiments.

If a comparison is made between the equation recommended by Gary, Ruben, and Ward and that recommended by Cragoe above, we find that for a gravity of 950 agreement may be obtained by subtracting 4% from the figures tabulated below. For the lightest samples used by Gary, Ruben, and Ward the difference from the figures tabulated below is -2%. It would seem, therefore, that the best means of obtaining the specific heat of a cracked or partially cracked oil is to make the following corrections to the tabulated figures:

No raw stock		subtract 4%
1 part raw stock	2 parts cracked	" 2%
2 " " "	1 " "	" 0%

It is considered that this rule would give trustworthy figures for cracked and partially cracked liquids down to a

specific gravity of 750, and that it would be far more reliable than extrapolating the equation derived by Gary, Rubin, and Ward

TABLE I
Specific Heat of Petroleum Oils in
B Th U / lb °F or g-cal / g °C

Density at 20°/4° C										
	1.000	0.990	0.980	0.850	0.800	0.750	0.700	0.650	0.600	
Specific Gravity 60°/60° F										
	1.004	0.954	0.904	0.854	0.804	0.754	0.705	0.655	0.605	
Degrees API at 60° F										
	94	16.8	25.0	34.2	44.4	56.2	69.2	84.5	102.0	
Temp °F	-100	0.342	0.351	0.361	0.371	0.383	0.395	0.409	0.424	0.441
	-90	0.347	0.355	0.366	0.376	0.388	0.400	0.414	0.429	0.447
	-80	0.351	0.359	0.371	0.381	0.393	0.405	0.419	0.435	0.452
	-70	0.356	0.364	0.375	0.386	0.398	0.410	0.424	0.440	0.458
	-60	0.360	0.369	0.380	0.391	0.402	0.416	0.430	0.446	0.464
	-50	0.365	0.374	0.384	0.396	0.407	0.421	0.435	0.452	0.470
	-40	0.369	0.378	0.389	0.401	0.412	0.426	0.441	0.457	0.476
	-30	0.374	0.383	0.394	0.406	0.417	0.431	0.446	0.463	0.482
	-20	0.378	0.388	0.399	0.410	0.422	0.436	0.452	0.468	0.487
	-10	0.383	0.392	0.403	0.415	0.427	0.442	0.457	0.474	0.493
	0	0.387	0.397	0.408	0.420	0.432	0.447	0.462	0.479	0.499
	10	0.391	0.401	0.413	0.425	0.437	0.452	0.467	0.484	0.505
	20	0.396	0.406	0.418	0.430	0.442	0.457	0.473	0.490	0.511
	30	0.400	0.411	0.423	0.434	0.447	0.462	0.478	0.496	0.516
	40	0.405	0.416	0.427	0.439	0.452	0.468	0.484	0.501	0.522
	50	0.409	0.420	0.432	0.444	0.457	0.473	0.489	0.507	0.528
	60	0.414	0.425	0.437	0.449	0.462	0.478	0.495	0.513	0.534
	70	0.418	0.429	0.441	0.454	0.467	0.483	0.500	0.518	0.539
	80	0.423	0.434	0.446	0.459	0.472	0.488	0.505	0.523	0.545
	90	0.427	0.438	0.451	0.464	0.477	0.493	0.510	0.529	0.551
	100	0.433	0.443	0.455	0.469	0.482	0.498	0.516	0.534	0.557
	110	0.437	0.448	0.460	0.474	0.487	0.503	0.521	0.540	0.563
	120	0.441	0.452	0.465	0.479	0.492	0.509	0.526	0.545	0.569
	130	0.445	0.457	0.470	0.484	0.498	0.514	0.531	0.551	0.574
	140	0.450	0.461	0.474	0.488	0.503	0.519	0.537	0.557	0.580
	150	0.455	0.466	0.479	0.493	0.508	0.524	0.542	0.562	0.586
	160	0.459	0.471	0.484	0.498	0.513	0.529	0.548	0.568	0.592
	170	0.464	0.475	0.489	0.503	0.518	0.534	0.553	0.573	0.597
	180	0.468	0.480	0.495	0.509	0.523	0.540	0.559	0.579	0.603
	190	0.473	0.484	0.499	0.513	0.528	0.545	0.564	0.584	0.609
	200	0.477	0.489	0.503	0.517	0.533	0.550	0.569	0.590	0.615
	210	0.482	0.494	0.508	0.522	0.538	0.555	0.574		
	220	0.486	0.498	0.512	0.527	0.543	0.560	0.580		
	230	0.490	0.503	0.517	0.532	0.548	0.566	0.585		
	240	0.495	0.507	0.521	0.537	0.553	0.571	0.590		
	250	0.500	0.512	0.527	0.542	0.558	0.576	0.596		
	260	0.504	0.517	0.531	0.547	0.563	0.581	0.601		
	270	0.509	0.521	0.536	0.552	0.568	0.587	0.606		
	280	0.513	0.526	0.541	0.557	0.573	0.592	0.612		
	290	0.518	0.530	0.545	0.561	0.578	0.597	0.617		
	300	0.522	0.535	0.550	0.566	0.583	0.603	0.623		
	310	0.527	0.539	0.555	0.571	0.588	0.607	0.627		
	320	0.531	0.544	0.560	0.576	0.593	0.613	0.633		
	330	0.535	0.549	0.564	0.581	0.598	0.618	0.638		
	340	0.539	0.553	0.569	0.586	0.603	0.623	0.643		
	350	0.544	0.558	0.574	0.591	0.608	0.628	0.648		
	360	0.549	0.562	0.579	0.596	0.613	0.633	0.654		
	370	0.553	0.567	0.584	0.601	0.618	0.639	0.660		
	380	0.558	0.572	0.589	0.605	0.623	0.644	0.665		
	390	0.562	0.577	0.593	0.610	0.628	0.649	0.670		
	400	0.567	0.581	0.598	0.615	0.633	0.654	0.675		
	410	0.571	0.585	0.602	0.619	0.637	0.658	0.679		
	420	0.575	0.590	0.607	0.624	0.642	0.663	0.684		
	430	0.580	0.595	0.612	0.629	0.647	0.668	0.689		
	440	0.584	0.599	0.616	0.634	0.652	0.673	0.694		
	450	0.589	0.604	0.621	0.639	0.657	0.678	0.699		
	460	0.594	0.609	0.626	0.644	0.662	0.683	0.704		
	470	0.598	0.613	0.630	0.648	0.666	0.687	0.708		
	480	0.603	0.618	0.635	0.653	0.671	0.692	0.713		
	490	0.607	0.622	0.640	0.658	0.676	0.697	0.718		
	500	0.612	0.627	0.645	0.663	0.681	0.702	0.723		
	510	0.616	0.632	0.649	0.668	0.686	0.707	0.728		
	520	0.621	0.636	0.654	0.673	0.691	0.712	0.733		
	530	0.625	0.640	0.658	0.677	0.695	0.716	0.737		
	540	0.630	0.645	0.663	0.682	0.700	0.721	0.742		
	550	0.634	0.650	0.668	0.687	0.705	0.726	0.747		

Temp °F	0.629	0.655	0.673	0.692	0.714
370	0.641	0.659	0.678	0.697	0.719
380	0.646	0.664	0.683	0.702	0.724
390	0.651	0.668	0.687	0.707	0.729
400	0.657	0.673	0.692	0.712	0.734
410	0.661	0.678	0.697	0.717	0.739
420	0.665	0.682	0.701	0.721	0.743
430	0.670	0.687	0.706	0.726	0.747
440	0.675	0.692	0.711	0.731	0.751
450	0.679	0.696	0.716	0.736	0.755
460	0.684	0.701	0.720	0.741	0.759
470	0.688	0.705	0.725	0.746	0.763
480	0.693	0.710	0.730	0.751	0.767
490	0.697	0.715	0.735	0.756	0.771
500	0.702	0.719	0.740	0.761	0.775
510	0.707	0.724	0.744	0.766	0.780
520	0.711	0.728	0.749	0.770	0.784
530	0.715	0.733	0.754	0.775	0.789
540	0.720	0.738	0.759	0.780	0.793
550	0.724	0.742	0.763	0.785	0.798
560	0.729	0.747	0.768	0.790	0.802
570	0.733	0.752	0.773	0.795	0.807
580	0.738	0.756	0.778	0.800	0.811
590	0.742	0.761	0.782	0.804	0.815
600	0.747	0.765	0.787	0.809	0.819
610	0.751	0.770	0.792		
620	0.755	0.774	0.796		
630	0.759	0.779	0.801		
640	0.764	0.784	0.806		
650	0.769	0.789	0.811		
660	0.773	0.793	0.815		
670	0.778	0.797	0.820		
680	0.783	0.802	0.825		
690	0.787	0.806	0.830		
700	0.792	0.811	0.834		
710	0.796	0.816	0.839		
720	0.801	0.820	0.844		
730	0.805	0.825	0.849		
740	0.809	0.829	0.853		
750	0.814	0.834	0.858		
760	0.818	0.839	0.863		
770	0.823	0.843	0.868		
780	0.827	0.848	0.872		
790	0.832	0.852	0.877		
800	0.836	0.857	0.881		

Heat Content of Petroleum Liquids

The heat content of liquids may be readily calculated from data on the specific heat of the liquid as described in a previous section. The equation for the heat content in B Th U per lb above 32° F is —

$$H = \int c dt$$

where specific heat $c = \frac{1}{\sqrt{S}} (0.388 + 0.00045t)$,

$$H = \text{B Th U per lb above } 32^\circ \text{ F}$$

$$S = \text{specific gravity } 60^\circ/60^\circ \text{ F,}$$

$$t = \text{temperature in } ^\circ \text{F}$$

The integration results in the formula

$$H = \frac{1}{\sqrt{S}} (0.388t + 0.00025t^2 - 12.65)$$

The tabulated results from this equation are given in Table II and are expressed as functions of density (20°/4° C), but equivalent values of specific gravity and degree API are also given. Extrapolation below -100° F. probably does not entail any large error, extension of calculated results beyond 1,000° F. should be done only when adequate experimental data do not exist.

The calculated values from the above equation [2, 1929] are in reasonable agreement with experimental data by Weir and Eaton [12, 1932], and by Gary, Rubin, and Ward [4, 1933], who have made determinations at temperatures as high as 950° F. The tabulated values are also shown on Fig. 2

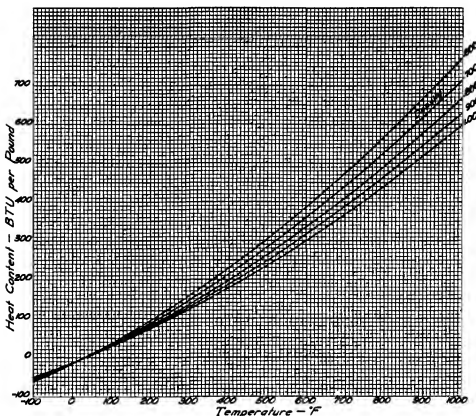

Fig 2 Heat content of petroleum liquids (above 32° F)

TABLE II
Heat Content of Petroleum Liquids in B THU
per lb (above 32° F)

		Density at 20°/4° C									
		1.000	0.950	0.900	0.850	0.800	0.750	0.700	0.650	0.600	
		Specific gravity (60°/60° F)									
		1.004	0.954	0.904	0.854	0.804	0.754	0.704	0.654	0.604	
		Degrees API at 60° F									
		9-4	16.8	25.0	34.2	44.4	56.2	69.2	84.5	102.0	
Temp °F		100	200	300	400	500	600	700	800	900	1000
-100	-49	-50	-52	-53	-55	-57	-59	-61	-63	66	71
-90	-45	-46	-47	-48	-50	-52	-54	-56	-59	66	71
-80	-41	-42	-43	-44	-46	-48	-50	-52	-54	66	71
-70	-38	-39	-40	-41	-42	-43	-45	-47	-49	66	71
-60	-34	-35	-36	-37	-38	-39	-40	-42	-44	66	71
-50	-30	-31	-32	-33	-34	-35	-36	-38	-40	66	71
-40	-26	-27	-28	-29	-30	-31	-32	-33	-35	66	71
-30	-22	-23	-24	-24	-25	-26	-27	-29	-31	66	71
-20	-19	-20	-20	-21	-22	-23	-23	-24	-25	66	71
-10	-15	-16	-16	-17	-17	-18	-19	-20	-21	66	71
0	-12	-13	-13	-13	-14	-15	-15	-16	-16	66	71
10	-8	-9	-9	-9	-10	-10	-11	-11	-11	66	71
20	-4	-5	-5	-5	-5	-5	-6	-6	-6	66	71
30	-1	-1	-1	-1	-1	-1	-1	-1	-1	66	71
40	2	2	3	3	3	3	3	4	4	66	71
50	7	7	8	8	9	9	9	9	9	66	71
60	10	10	11	11	12	13	13	14	14	66	71
70	15	15	16	16	17	17	18	19	20	66	71
80	18	19	20	20	21	22	23	24	25	66	71
90	23	24	25	25	26	27	29	30	31	66	71
100	28	29	30	31	32	33	34	35	36	66	71
110	31	32	33	34	36	38	39	40	41	66	71
120	35	36	37	39	41	43	44	45	47	66	71
130	40	41	43	44	46	48	49	51	53	66	71
140	45	46	47	49	51	53	54	57	59	66	71
150	49	50	52	53	56	58	60	63	65	66	71

Temp °F	160	170	180	190	200	210	220	230	240	250	260	270	280	290	300	310	320	330	340	350	360	370	380	390	400	410	420	430	440	450	460	470	480	490	500	510	520	530	540	550	560	570	580	590	600																																																																																																																																																																																																																																																																																																																																																																																																																																																																																																																																																																																																																																																																																																																																																																																																																																																																																																																																																																																														
53	55	57	59	61	63	66	68	71	74	77	80	83	86	89	92	95	98	101	104	107	110	113	116	119	122	125	128	131	134	137	140	143	146	149	152	155	158	161	164	167	170	173	176	179	182	185	188	191	194	197	200	203	206	209	212	215	218	221	224	227	230	233	236	239	242	245	248	251	254	257	260	263	266	269	272	275	278	281	284	287	290	293	296	299	302	305	308	311	314	317	320	323	326	329	332	335	338	341	344	347	350	353	356	359	362	365	368	371	374	377	380	383	386	389	392	395	398	401	404	407	410	413	416	419	422	425	428	431	434	437	440	443	446	449	452	455	458	461	464	467	470	473	476	479	482	485	488	491	494	497	500	503	506	509	512	515	518	521	524	527	530	533	536	539	542	545	548	551	554	557	560	563	566	569	572	575	578	581	584	587	590	593	596	599	602	605	608	611	614	617	620	623	626	629	632	635	638	641	644	647	650	653	656	659	662	665	668	671	674	677	680	683	686	689	692	695	698	701	704	707	710	713	716	719	722	725	728	731	734	737	740	743	746	749	752	755	758	761	764	767	770	773	776	779	782	785	788	791	794	797	800	803	806	809	812	815	818	821	824	827	830	833	836	839	842	845	848	851	854	857	860	863	866	869	872	875	878	881	884	887	890	893	896	899	902	905	908	911	914	917	920	923	926	929	932	935	938	941	944	947	950	953	956	959	962	965	968	971	974	977	980	983	986	989	992	995	998	1001	1004	1007	1010	1013	1016	1019	1022	1025	1028	1031	1034	1037	1040	1043	1046	1049	1052	1055	1058	1061	1064	1067	1070	1073	1076	1079	1082	1085	1088	1091	1094	1097	1100	1103	1106	1109	1112	1115	1118	1121	1124	1127	1130	1133	1136	1139	1142	1145	1148	1151	1154	1157	1160	1163	1166	1169	1172	1175	1178	1181	1184	1187	1190	1193	1196	1199	1202	1205	1208	1211	1214	1217	1220	1223	1226	1229	1232	1235	1238	1241	1244	1247	1250	1253	1256	1259	1262	1265	1268	1271	1274	1277	1280	1283	1286	1289	1292	1295	1298	1301	1304	1307	1310	1313	1316	1319	1322	1325	1328	1331	1334	1337	1340	1343	1346	1349	1352	1355	1358	1361	1364	1367	1370	1373	1376	1379	1382	1385	1388	1391	1394	1397	1400	1403	1406	1409	1412	1415	1418	1421	1424	1427	1430	1433	1436	1439	1442	1445	1448	1451	1454	1457	1460	1463	1466	1469	1472	1475	1478	1481	1484	1487	1490	1493	1496	1499	1502	1505	1508	1511	1514	1517	1520	1523	1526	1529	1532	1535	1538	1541	1544	1547	1550	1553	1556	1559	1562	1565	1568	1571	1574	1577	1580	1583	1586	1589	1592	1595	1598	1601	1604	1607	1610	1613	1616	1619	1622	1625	1628	1631	1634	1637	1640	1643	1646	1649	1652	1655	1658	1661	1664	1667	1670	1673	1676	1679	1682	1685	1688	1691	1694	1697	1700	1703	1706	1709	1712	1715	1718	1721	1724	1727	1730	1733	1736	1739	1742	1745	1748	1751	1754	1757	1760	1763	1766	1769	1772	1775	1778	1781	1784	1787	1790	1793	1796	1799	1802	1805	1808	1811	1814	1817	1820	1823	1826	1829	1832	1835	1838	1841	1844	1847	1850	1853	1856	1859	1862	1865	1868	1871	1874	1877	1880	1883	1886	1889	1892	1895	1898	1901	1904	1907	1910	1913	1916	1919	1922	1925	1928	1931	1934	1937	1940	1943	1946	1949	1952	1955	1958	1961	1964	1967	1970	1973	1976	1979	1982	1985	1988	1991	1994	1997	2000	2003	2006	2009	2012	2015	2018	2021	2024	2027	2030	2033	2036	2039	2042	2045	2048	2051	2054	2057	2060	2063	2066	2069	2072	2075	2078	2081	2084	2087	2090	2093	2096	2099	2102	2105	2108	2111	2114	2117	2120	2123	2126	2129	2132	2135	2138	2141	2144	2147	2150	2153	2156	2159	2162	2165	2168	2171	2174	2177	2180	2183	2186	2189	2192	2195	2198	2201	2204	2207	2210	2213	2216	2219	2222	2225	2228	2231	2234	2237	2240	2243	2246	2249	2252	2255	2258	2261	2264	2267	2270	2273	2276	2279	2282	2285	2288	2291	2294	2297	2300	2303	2306	2309	2312	2315	2318	2321	2324	2327	2330	2333	2336	2339	2342	2345	2348	2351	2354	2357	2360	2363	2366	2369	2372	2375	2378	2381	2384	2387	2390	2393	2396	2399	2402	2405	2408	2411	2414	2417	2420	2423	2426	2429	2432	2435	2438	2441	2444	2447	2450	2453	2456	2459	2462	2465	2468	2471	2474	2477	2480	2483	2486	2489	2492	2495	2498	2501	2504	2507	2510	2513	2516	2519	2522	2525	2528	2531	2534	2537	2540	2543	2546	2549	2552	2555	2558	2561	2564	2567	2570	2573	2576	2579	2582	2585	2588	2591	2594	2597	2600	2603	2606	2609	2612	2615	2618	2621	2624	2627	2630	2633	2636	2639	2642	2645	2648	2651	2654	2657	2660	2663	2666	2669	2672	2675	2678	2681	2684	2687	2690	2693	2696	2699	2702	2705	2708	2711	2714	2717	2720	2723	2726	2729	2732	2735	2738	2741	2744	2747	2750	2753	2756	2759	2762	2765	2768	2771	2774	2777	2780	2783	2786	2789	2792	2795	2798	2801	2804	2807	2810	2813	2816	2819	2822	2825	2828	2831	2834	2837	2840	2843	2846	2849	2852	2855	2858	2861	2864	2867	2870	2873	2876	2879	2882	2885	2888	2891	2894	2897	2900	2903	2906	2909	2912	2915	2918	2921	2924	2927	2930	2933	2936	2939	2942	2945	2948	2951	2954	2957	2960	2963	2966	2969	2972	2975	2978	2981	2984	2987	2990	2993	2996	2999	3002	3005	3008	3011	3014	3017	3020	3023	3026	3029	3032	3035	3038	3041	3044	3047	3050	3053	

Temp °F	306	315	322	332	341	353	366	379	394
610	306	315	322	332	341	353	366	379	394
620	313	322	329	339	349	361	374	387	403
630	320	328	337	347	357	367	382	396	412
640	326	336	344	353	364	378	390	404	421
650	334	342	351	361	372	386	398	413	430
660	340	350	359	368	380	394	406	422	439
670	347	357	366	376	388	402	414	431	448
680	354	364	374	383	396	410	423	439	457
690	361	371	380	390	403	418	431	447	466
700	368	377	388	399	411	427	442	456	475
710	374	384	394	406	419	436	447	465	483
720	381	392	402	414	427	442	456	474	493
730	389	400	410	422	435	450	464	483	501
740	397	406	417	430	443	458	474	491	511
750	403	414	4	438	451	466	482	500	520
760	410	422	433	445	459	474	490	509	529
770	417	429	440	453	467	482	499	517	539
780	425	436	448	461	476	493	508	526	548
790	433	444	456	469	484	499	517	537	558
800	440	452	464	478	492	508	526	545	568
810	447	459	472	485	501	516	535	553	576
820	455	467	480	492	511	525	544	564	585
830	463	475	488	501	520	533	554	573	594
840	470	483	497	510	528	542	563	582	604
850	478	490	503	518	534	551	572	59	613
860	486	499	512	526	543	560	581	601	623
870	494	507	520	535	552	569	590	611	637
880	501	514	528	543	561	578	599	620	642
890	509	522	537	551	569	587	609	630	651
900	517	530	545	561	578	597	618	640	661
910	525	539	553	569	587	605	627	650	671
920	533	543	561	577	596	614	637	659	681
930	541	555	570	586	605	624	647	669	692
940	550	564	578	595	614	633	656	679	702
950	557	571	587	603	623	642	666	689	713
960	566	580	596	613	632	652	676	699	724
970	574	589	605	623	641	661	685	709	735
980	582	597	614	631	650	672	695	720	746
990	590	605	622	639	660	681	705	730	758
1000	599	614	631	649	669	691	715	741	771

Heat Content of Petroleum Vapours at Atmospheric Pressure

The total heat of petroleum vapours has been calculated by means of the equation of Weir and Eaton [12 1932] which is stated by Gary Rubin and Ward [4 1933] to be satisfactory for all types of stocks at atmospheric pressure. This equation is

$$H_v = (215 - 87s) + 0.415 \sum (0.104s)_i + (0.00031 - 0.000078s)_i t^2$$

where H_v total heat in B Th U per lb above 32° F
 s specific gravity of the oil (60/60° F)
 t temperature °F

The computed total heats are presented in tabular form in Table III as well as graphically in Fig 3 for oils in the density range from 0.6 to 1.0 and for temperatures from -100 to 1000° F. Existing experimental data do not seem to warrant the extension of the computations beyond 1,000° F, although engineering practice may demand occasional use beyond that limit. The Joule Thomson effect upon the heat content of vapours at pressures above atmospheric is well known and must be taken into account in important calculations. The estimation of heat content of vapours at super atmospheric pressures by this means is dealt with later.

TABLE III

Heat Content of Petroleum Vapours at Atmospheric Pressure in B Th U per lb above 32° F

Density at 20° C	0.950	0.900	0.850	0.800	0.750	0.700	0.650	0.600	
Specific gravities (60/60° F)	1.004	0.954	0.904	0.854	0.804	0.754	0.704	0.654	0.604
Degree API at 60° F	9.4	16.8	25.0	34.2	44.4	56.2	69.2	84.5	102.0

Temp °F	99	103	107	111	114	118	122	126	130
100	99	103	107	111	114	118	122	126	130
90	101	105	109	114	117	121	125	129	133
80	104	108	112	117	120	124	128	132	136
70	107	111	115	119	121	127	131	135	139
60	110	114	118	123	127	131	134	138	141
50	113	117	121	126	129	133	137	142	146
40	116	120	124	128	133	137	141	145	149
30	118	123	127	131	136	139	144	148	152
20	121	126	130	134	139	143	147	151	156
10	124	129	133	136	142	146	150	154	159
0	128	132	136	141	145	149	154	158	162
-10	130	135	139	144	148	153	157	162	166
-20	133	138	142	147	152	157	161	165	170
-30	136	141	145	151	155	160	164	169	173
-40	140	144	148	154	159	164	168	172	177
-50	143	148	152	158	162	167	172	176	181
-60	146	151	156	161	166	171	175	180	185
-70	150	154	159	165	169	174	179	183	188
-80	154	158	163	168	173	178	183	187	192

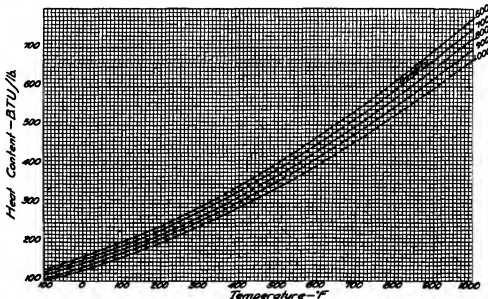

Fig 3 Heat content of petroleum vapours above 32° F at atmospheric pressure

Temp °F	176	182	188	194	200	206	212	218	224	230	236	242	248	254	260	266	272	278	284	290	296	302	308	314	320	326	332	338	344	350	356	362	368	374	380	386	392	398	404	410	416	422	428	434	440	446	452	458	464	470	476	482	488	494	500	506	512	518	524	530	536	542	548	554	560	566	572	578	584	590	596	602	608	614	620	626	632	638	644	650	656	662	668	674	680	686	692	698	704	710	716	722	728	734	740	746	752	758	764	770																								
90	157	162	167	172	177	182	186	191	196	200	205	210	215	220	225	230	235	240	245	250	255	260	265	270	275	280	285	290	295	300	305	310	315	320	325	330	335	340	345	350	355	360	365	370	375	380	385	390	395	400	405	410	415	420	425	430	435	440	445	450	455	460	465	470	475	480	485	490	495	500	505	510	515	520	525	530	535	540	545	550	555	560	565	570	575	580	585	590	595	600	605	610	615	620	625	630	635	640	645	650	655	660	665	670	675	680	685	690	695	700	705	710	715	720	725	730	735	740	745	750	755	760	765	770

Heat Content of Petroleum Vapours at Super-atmospheric Pressures

The effect of pressure upon the heat content of petroleum vapours, though small compared to the effect of temperature, is important. Estimation of the correction for the Joule-Thomson effect can be made readily from critical data and the molecular weight of the hydrocarbon or mixture under consideration. The assumption is made that a mixture will have the average properties of the component hydrocarbons.

Lewis and Luke (8, 1932) have suggested the following equation for estimating difference in total heat,

$$H_1 - H_0 = -(S-1)FRT(1-Z) - RT(1-Z)$$

where

$$H_1 - H_0 = \text{difference in Total Heat,}$$

Z = ideal gas law correction for volume at high pressure,

R = gas constant,

T = absolute temperature,

S and F are empirical constants,

when plotted [6] as shown in Figs. 4 and 5, the Joule-Thomson effect is obtained as a function of molecular weight, reduced temperature, and reduced pressure.

The approximation derived by Watson and Nelson [11, 1933] from compressibility data of Brown, Souder, and Smith [1, 1932], if plotted with the same coordinates as used in the present article, give good agreement with experimental results on pentane [9, 1935] and fair agreement with experimental data on naphtha [10, 1934].

Calculations of the total heats of oils in the density range 0.6 to 1.0 and for temperatures from 0 to 1,000°F. are tabulated in Table IV for pressures 0, 50, 100, 200, 300, 500, and 750 lb per sq in.

TABLE IV

Heat Content of Petroleum Vapours at Super-atmospheric Pressures

In B Th U per lb above 32° F
Density at 20°/4° C

1 000 0 930 0 900 0 850 0 800 0 750 0 700 0 650 0 600

Specific gravity 60°/60° F

1 004 0 954 0 904 0 854 0 804 0 754 0 704 0 654 0 604

Degrees API at 60° F

9 4 16 8 25 0 34 2 44 4 56 2 69 2 84 5 102 0

Pressure = 0 lb per sq in

Temp °F	161	166	171	176	181	185	190	195	200
100	161	166	171	176	181	185	190	195	200
200	199	204	210	215	221	226	232	237	243
300	242	248	254	261	267	273	279	284	290
400	288	295	303	310	317	324	331	338	345
500	341	349	357	365	372	380	387	395	403
600	397	406	415	424	433	442	451	459	468
700	459	468	477	487	497	508	517	528	538
800	525	536	547	557	568	578	589	600	612
900	595	607	619	631	643	655	667	679	692
1,000	670	683	697	710	723	737	750	764	777

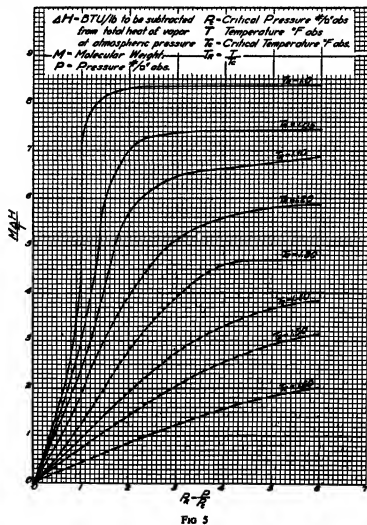
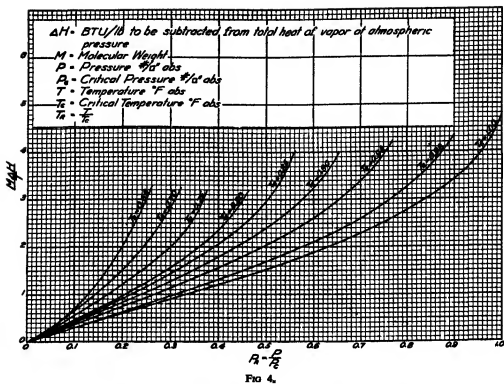

LATENT HEAT DATA FOR HYDROCARBONS, PETROLEUM PRODUCTS, AND MISCELLANEOUS SUBSTANCES

By E. S. L. BEALE, M A , F Inst P.
Consultant in Engineering Physics, London

LATENT heat data is required for heat-transfer calculations, and it is desirable to have some means of estimating the latent heat of fusion or of vaporization in any particular case even if this is only approximate. In the case of petroleum products this can often be arrived at from a consideration of the data for pure hydrocarbons when there is not some empirical correlation of the data for petroleum products which is applicable. For instance, the latent heat of fusion of paraffin waxes may be estimated from the data of the higher members of the normal paraffins

Latent Heat of Fusion

In Table I the latent heats of fusion of pure paraffins are those given by Parks and Todd [7, 1929] and are probably accurate to 0.5 cal per g. The data for various hydrocarbons other than normal paraffins, given by Parks and Huffman [6, 1931] is shown in Table II. This table is also given in *Technical Data on Fuel*

The melting points given in the tables were obtained by plotting the values given by Parks and Todd, by the *ICT* and by the Bureau of Standards [2, 1932], and taking the figures to the nearest 0.5° C from the best curve drawn through the points. Below $C_{20}H_{42}$ there is substantial agreement on a stepped curve, above $C_{23}H_{48}$ the curve is smooth, but there is a second set of determinations given by the *ICT* which lie about 5° C higher and these have been disregarded. The figures in the tables are in good agreement with Parks and Todd (approx $\pm 1^\circ C$)

TABLE I
Fusion Data for Normal Paraffins

Formula	M P ° C	Latent heat of fusion cal per g	Formula	M P ° C	Latent heat of fusion cal per g
CH_4	-182.6	14.5	$C_{13}H_{28}$	32.0	51.6
C_2H_6	-172.0	19.2	$C_{14}H_{30}$	37.0	52.1
C_3H_8	-189.9	16.2	$C_{15}H_{32}$	40.5	52.5
C_4H_{10}	-135.0	26.9	$C_{16}H_{34}$	44.5	53.0
C_5H_{12}	-131.5	27.4	$C_{17}H_{36}$	47.5	52.9
C_6H_{14}	-94.5	34.1	$C_{18}H_{38}$	50.5	53.0
C_7H_{16}	-91.0	34.4	$C_{19}H_{40}$	54.0	53.3
C_8H_{18}	-56.5	40.3	$C_{20}H_{42}$	56.5	53.5
C_9H_{20}	-51.0	41.0	$C_{21}H_{44}$	59.5	53.7
$C_{10}H_{22}$	-32.0	44.1	$C_{22}H_{46}$	61.5	53.6
$C_{11}H_{24}$	-26.5	44.6	$C_{23}H_{48}$	63.5	53.6
$C_{12}H_{26}$	-12.0	46.8	$C_{24}H_{50}$	66.0	53.8
$C_{13}H_{28}$	-6.5	47.4	$C_{25}H_{52}$	68.0	54.0
$C_{14}H_{30}$	+5.5	49.0	$C_{26}H_{54}$	69.5	54.0
$C_{15}H_{32}$	10.0	49.4	$C_{27}H_{56}$	71.0	54.1
$C_{16}H_{34}$	20.0	50.8	$C_{28}H_{58}$	73.0	
$C_{17}H_{36}$	22.5	50.8	$C_{29}H_{60}$	74.5	
$C_{18}H_{38}$	28.0	51.2	$C_{30}H_{62}$	76.5	

The latent heat of fusion of all branched-chain paraffins appear to be lower than that of the corresponding normal paraffins, that for the *isoparaffins* being about 20% lower. In the case of 2,2,3,3-tetramethyl butane, which is the most branched of the isomeric octanes, the latent heat of fusion is only 14.9 cal per g, i.e. 37% of that for *n*-octane. The

melting point of this compound is also anomalous, being 104° C, that is, very much higher than *n*-octane

TABLE II
Fusion Data for Various Hydrocarbons

Formula	Name	M P ° C	Heat of fusion	
			Cal per g	Cal per mole
<i>Branched Paraffins</i>				
C_4H_{10}	2 Methylbutane	-160.5	16.9	1,220
C_5H_{12}	2 Methylhexane	-119.1	21.2	2,120
C_5H_{12}	1 Fitylpentane	-118.8	22.6	2,260
C_6H_{14}	2,2 Dimethylpentane	-125.0	14.0	1,400
C_6H_{14}	2,4 Dimethylpentane	120.6	16.0	1,600
C_7H_{16}	3,3 Dimethylpentane	134.9	16.9	1,690
C_7H_{16}	2,2,3 Trimethylbutane	25.4	5.1	530
C_8H_{18}	2,2,4 Trimethylpentane	107.8	18.9	2,160
C_8H_{18}	Hexamethylthane	+104.0	14.9	1,700
<i>Aliphatic Olefins</i>				
C_3H_6	Ethylene	164.9	25.0	700
C_4H_8	Propylene	184.9	16.7	700
C_5H_{10}	Trimethylethylene	134.2	25.7	1,800
C_5H_{10}	Disobutylene	101.0	16.8	1,880
<i>Aromatic Hydrocarbons</i>				
C_6H_6	Benzene	+5.5	30.1	2,350
C_6H_6	Toluene	95.1	17.2	1,580
C_6H_6	<i>o</i> Xylene	25.3	29.3	3,110
C_6H_6	<i>m</i> Xylene	53.5	25.8	2,740
C_6H_6	<i>p</i> Xylene	-13.2	38.1	4,040
C_6H_6	Ethylbenzene	-95.1	20.6	2,180
C_6H_6	Pseudo cumene	44.5	25.2	3,030
C_6H_6	Naphthalene	+80.0	36.0	4,610
C_6H_6	Camphene	+51.0	57.0	7,600
C_6H_6	Durene	+79.3	37.4	5,020
C_6H_6	Isodurene	-24.0	23.0	3,080
C_6H_6	Prehnatene	-7.7	20.0	2,680
C_6H_6	<i>p</i> Cymene	68.9	17.2	2,310
C_6H_6	<i>n</i> Butylbenzene	-88.5	19.5	2,520
C_6H_6	<i>tert</i> Butylbenzene	58.1	14.9	2,000
C_6H_6	β Methyl-naphthalene	+34.1	20.1	2,850
C_6H_6	Diphenyl	+68.6	28.8	4,440
C_6H_6	Hexamethylbenzene	+165.5	30.4	4,930
C_6H_6	Diphenylmethane	+25.2	26.4	4,440
C_6H_6	Anthracene	+216.5	38.7	6,890
C_6H_6	Phenanthrene	+96.3	25.0	4,450
C_6H_6	Toluene	+60.0	28.7	5,110
C_6H_6	Stilbene	+124.0	40.0	7,200
C_6H_6	Dibenzyl	+51.4	30.7	5,600
C_6H_6	Triphenylmethane	+92.1	21.1	5,150
<i>Hydroaromatic Hydrocarbons and Naphthenes</i>				
C_6H_6	Cyclohexane	-104.6	9.6	790
C_6H_6	Cyclohexane	-6.2	7.4	620
C_7H_8	Methylcyclopentane	-143.0	19.5	1,640
C_7H_8	1,2 Dimethylcyclopentane	-119.0	15.7	1,540
C_7H_8	Methylcyclohexane	-126.9	16.2	1,590
C_7H_8	Δ_1 Dihydroindaphthalene	+23.9	22.4	2,920
C_7H_8	Dihydrophenanthrene	+94.0	17.6	3,160

The latent heat of fusion of some miscellaneous substances are given in Table III

TABLE III

Compound	Formula	M.P., °C	Latent heat of fusion, g cal per g
Carbon dioxide	CO ₂	-56.2	45.30
Carbon monoxide	CO	-206.0	8.00
<i>p</i> -Cresol	C ₈ H ₁₀ O	34.6	26.8
Ethyl alcohol	C ₂ H ₆ O	-114.6	24.89
Methyl alcohol	CH ₄ O	-97.0	16.39
Mercury	Hg	-39.0	2.78
Sulphur	S	115.0	8.80
Hydrogen sulphide	H ₂ S	-82.9	18.60
Sulphuric acid	H ₂ SO ₄	10.35	24.03
"	H ₂ SO ₄ H ₂ O	8.56	39.08
Water	H ₂ O	0	79.70

Latent Heat of Vaporization

The latent heat of vaporization of all substances varies with the pressure and becomes zero at the critical point. This variation is shown on Fig. 1 for the normal paraffin series, which forms a consistent family of lines. In the case of the higher members of this series for which there are no data the latent heats were calculated by the method described by J. B. Maxwell [5, 1932] from the slope of the vapour pressure lines and the specific volumes of liquid and vapour. This method is probably the most reliable one for estimating the latent heat of high-boiling compounds.

The data given in Fig. 1 can be replotted in the form of a graph of latent heat against vaporization temperature. This is shown in Fig. 2. When using this chart it is not necessary to know the molecular weight of the paraffin in order to find the latent heat, but merely the pressure and temperature at which it is boiling. The line marked 760 mm may be used for all pressures from 1 mm up to 1,000 mm of mercury with an accuracy of $\pm 5\%$.

A chart on similar lines for the molal heats of vaporization of normal paraffins is given by Schultz [8, 1930], as shown in Fig. 3.

Latent heats of vaporization of hydrocarbons other than normal paraffins are given in Table IV. Most of the latent heats are given at temperatures close to the boiling-points at 760 mm so that they may be compared with normal

paraffins shown on Fig. 2. It will be observed that the aromatics and, to a lesser extent, the naphthenes have a higher latent heat than the normal paraffins at the same boiling-point.

TABLE IV

Compound	Formula	Temperature, °C	Latent heat of vaporization, g cal per g
Acetylene	C ₂ H ₂	-83.6	198.0
Ethylene	C ₂ H ₄	-103.8	125.0
Propylene	C ₃ H ₆	-47	109.0
Isobutane	C ₄ H ₁₀	-10	87.44
"	"	0	85.05
"	"	10	82.42
"	"	20	79.55
Isobutylene	C ₄ H ₈	-7	9.5
Isopentane	C ₅ H ₁₂	13	88.63
Amylene	C ₅ H ₁₀	12.5	75.01
Hexylene	C ₆ H ₁₄	0	92.76
Cyclohexane	C ₆ H ₁₂	80	85.60
Cyclohexane	C ₆ H ₁₂	81.6	88.68
Benzene	C ₆ H ₆	60	97.47
"	"	80	94.17
"	"	100	90.57
"	"	140	82.59
"	"	160	78.48
"	"	180	74.08
"	"	220	62.09
"	"	260	43.78
"	"	288.5	0
Toluene	C ₇ H ₈	109.6	86.53
Methylcyclohexane	C ₇ H ₁₄	99.9	76.90
Dimethylcyclopentane	C ₇ H ₁₄	91	80.99
<i>o</i> -Xylene	C ₈ H ₁₀	141.4	82.87
<i>m</i> -Xylene	C ₈ H ₁₀	133.5	81.65
<i>p</i> -Xylene	C ₈ H ₁₀	137.1	81.01
Ethyl benzene	C ₈ H ₁₀	135.2	81.13
Dimethylcyclohexane	C ₈ H ₁₆	118.5	71.67
4-Dimethylheptane	C ₈ H ₁₈	117.2	70.83
<i>n</i> -Propyl benzene	C ₈ H ₁₈	157	71.91
Pseudo-cumene	C ₈ H ₁₈	169	73.58
Mesitylene	C ₈ H ₁₀	165	74.3
Naphthalene	C ₁₀ H ₈	218	75.49
<i>p</i> -Cymene	C ₁₀ H ₁₆	178	67.61
Turpentine	C ₁₀ H ₁₈	156	68.56

Fig. 1 may be used for estimating the latent heat of vaporization at various temperatures and pressures of these hydrocarbons, when proper data are lacking, by making the assumption that there will be the same *proportional change* in the latent heat at corresponding reducing temperatures for the hydrocarbon as for the normal paraffin having the same critical temperature. To apply this method it is clearly necessary to know the critical temperature of the hydrocarbon and the latent heat at some temperature or pressure.

The latent heats of vaporization of some hydrocarbons and other liquids together with their variations with temperature are given by Chilton, Colburn, and Vernon in the form of an alignment chart (Fig. 4) taken from the *Chemical Engineers' Handbook*.

The latent heats of petroleum products have been the subject of various investigations and a general correlation was made by Crago

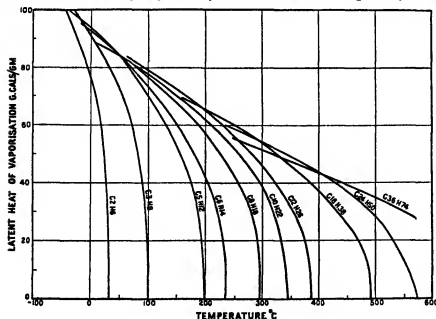

FIG. 1 Latent heat-temperature normal paraffins

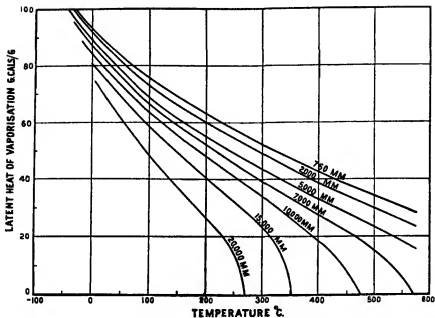
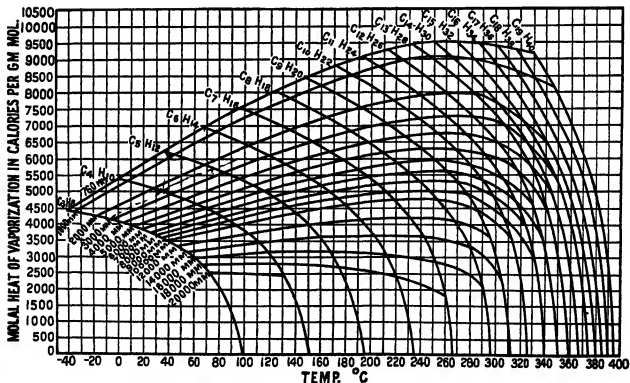

FIG 2 Latent heat-temperature normal paraffins

FIG 3 Molal heat of vaporization of hydrocarbons as a function of temperature
(Reproduced by permission from 'Industrial and Engineering Chemistry', 23, 788)

[3, 1929] based on the specific gravity of the oil at 60° F. The formula adopted was

$$L = \frac{1}{d}(1109 - 0.09t),$$

where L = latent heat in B Th U per lb,

d = specific gravity at 60/60° F,

t = temperature in ° F

LATENT HEATS OF VAPORIZATION

T_c = Critical Temperature, degrees Nelson (Deg C abs)
 T = Temperature, degrees Nelson (Deg C abs.)

No.	Substance	Boiling Pt	T_c
1	Acetic Acid	100	510
2	Acetone	100	450
3	Ammonia	100	350
4	Benzene	100	400
5	Carbon Dioxide	100	300
6	" Diethyl Ether	100	400
7	" Ethyl Alcohol	100	400
8	" Ethyl Ether	100	400
9	" Ethyl Nitrate	100	400
10	" Nitrobenzene	100	400
11	" Nitroethane	100	400
12	" Nitropropane	100	400
13	" Nitrotoluene	100	400
14	" Nitrobenzene	100	400
15	" Nitroethane	100	400
16	" Nitropropane	100	400
17	" Nitrotoluene	100	400
18	" Nitrobenzene	100	400
19	" Nitroethane	100	400
20	" Nitropropane	100	400
21	" Nitrotoluene	100	400
22	" Nitrobenzene	100	400
23	" Nitroethane	100	400
24	" Nitropropane	100	400
25	" Nitrotoluene	100	400
26	" Nitrobenzene	100	400
27	" Nitroethane	100	400
28	" Nitropropane	100	400
29	" Nitrotoluene	100	400
30	" Nitrobenzene	100	400
31	" Nitroethane	100	400
32	" Nitropropane	100	400
33	" Nitrotoluene	100	400
34	" Nitrobenzene	100	400
35	" Nitroethane	100	400
36	" Nitropropane	100	400
37	" Nitrotoluene	100	400
38	" Nitrobenzene	100	400
39	" Nitroethane	100	400
40	" Nitropropane	100	400
41	" Nitrotoluene	100	400
42	" Nitrobenzene	100	400
43	" Nitroethane	100	400
44	" Nitropropane	100	400
45	" Nitrotoluene	100	400
46	" Nitrobenzene	100	400
47	" Nitroethane	100	400
48	" Nitropropane	100	400
49	" Nitrotoluene	100	400
50	" Nitrobenzene	100	400
51	" Nitroethane	100	400
52	" Nitropropane	100	400
53	" Nitrotoluene	100	400
54	" Nitrobenzene	100	400
55	" Nitroethane	100	400
56	" Nitropropane	100	400
57	" Nitrotoluene	100	400
58	" Nitrobenzene	100	400
59	" Nitroethane	100	400
60	" Nitropropane	100	400
61	" Nitrotoluene	100	400
62	" Nitrobenzene	100	400
63	" Nitroethane	100	400
64	" Nitropropane	100	400
65	" Nitrotoluene	100	400
66	" Nitrobenzene	100	400
67	" Nitroethane	100	400
68	" Nitropropane	100	400
69	" Nitrotoluene	100	400
70	" Nitrobenzene	100	400
71	" Nitroethane	100	400
72	" Nitropropane	100	400
73	" Nitrotoluene	100	400
74	" Nitrobenzene	100	400
75	" Nitroethane	100	400
76	" Nitropropane	100	400
77	" Nitrotoluene	100	400
78	" Nitrobenzene	100	400
79	" Nitroethane	100	400
80	" Nitropropane	100	400
81	" Nitrotoluene	100	400
82	" Nitrobenzene	100	400
83	" Nitroethane	100	400
84	" Nitropropane	100	400
85	" Nitrotoluene	100	400
86	" Nitrobenzene	100	400
87	" Nitroethane	100	400
88	" Nitropropane	100	400
89	" Nitrotoluene	100	400
90	" Nitrobenzene	100	400
91	" Nitroethane	100	400
92	" Nitropropane	100	400
93	" Nitrotoluene	100	400
94	" Nitrobenzene	100	400
95	" Nitroethane	100	400
96	" Nitropropane	100	400
97	" Nitrotoluene	100	400
98	" Nitrobenzene	100	400
99	" Nitroethane	100	400
100	" Nitropropane	100	400

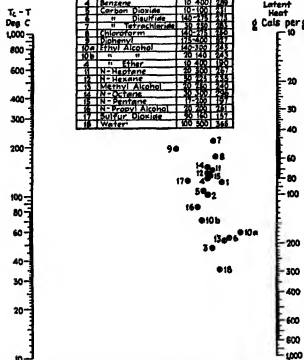

FIG 4 (Reproduced by permission from 'Chemical Engineers' Handbook', 1934 McGraw-Hill & Co)

A nomogram based on this formula given by A H Goodliffe [4, 1934] is shown in Fig 5

A more recent correlation has been made based on the U O P characterization factor (see article [9])

The curves in Figs 1, 2, and 3 can be made use of in many cases with slight modifications for cuts from paraffin base and mixed base crudes. For instance, the latent heat of a naphtha (mol wt. 110) was calculated over a wide pressure range up to the critical point by Bahkik and Kay [1, 1932] from the measured p-v-t relationships. This applied to vaporization at constant temperature and the results agree well with these figures

These figures may be used directly for reasonably narrow cuts. For wide cuts near the critical temperature it is more accurate to proceed as follows. The vaporization temperature at 760 mm must be known, and then from Fig 2 it is possible to read the latent heat at this temperature. This may then be plotted on Fig. 1 and will give one point on the latent heat line for the cut. A second point may be obtained by estimating the critical temperature of the cut, and plotting this at a latent heat of 0. A latent heat curve may then be drawn agreeing with the general shape of the

family on the graph. The latent heat of vaporization of some miscellaneous substances are given in the following

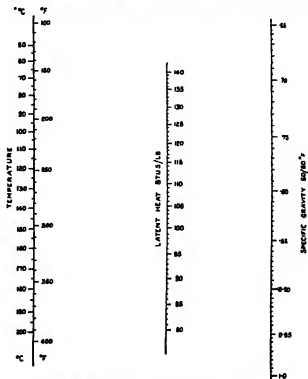

FIG 5 (Reproduced by permission from 'Technical Data on Fuel', p 52 Edited by H M Spiers)

Table V, the data being taken chiefly from the International Critical Tables and Technical Data on Fuel

TABLE V

Substance	Formula	Temp, °C	Latent heat of vaporization, g cal per g
Air		-194	51
Ammonia	NH ₃	-45	335
"	"	-35	328
"	"	-33.4	327
"	"	-30	325
"	"	-20	317
"	"	-10	310
"	"	0	301
"	"	+10	293
"	"	20	284
"	"	30	274
"	"	40	263
"	"	50	251
"	"	132.5	0
Carbon dioxide	CO ₂	-78.5	137.8
"	"	-50	83.4
"	"	-40	79.5
"	"	-20	68.8
"	"	0	55.9
"	"	+10	46.6
"	"	20	35.1
"	"	30	11.95
"	"	31.1	0
Chlorex (ββ-dichlorodiethyl ether)	C ₂ H ₄ OCl ₂	178	76
Freon (Dichlorodifluoromethane)	CClF ₂	-29.8	40.4
Ethyl alcohol	C ₂ H ₅ O	78.3	204.3
Ethyl ether	C ₂ H ₅ O	34.6	83.8
Ethylene glycol	C ₂ H ₄ O	197	191.1
Ethylene oxide	C ₂ H ₄ O	13	138.6

PHYSICAL AND CHEMICAL PROPERTIES

TABLE V (cont)

Substance	Formula	Temp. C	Latent heat of vaporiza- tion, g cal per g
Furfural	C ₅ H ₄ O ₂	160.5	107.5
Hydrogen sulphide	H ₂ S	-61.4	131.9
Isobutyl alcohol	C ₄ H ₁₀ O	106.9	138.1
Isopropyl alcohol	C ₃ H ₈ O	82.8	159.3
Methyl alcohol	CH ₃ O	64.65	262.8
Methyl chloride	CH ₂ Cl	-23.73	102.2
Pheno ^a	C ₆ H ₆ O	181.5	125
Propyl alcohol (n)	C ₃ H ₇ O	97.2	164.4
Sulphur dioxide	SO ₂	-10	94.8
" "	"	0	91.3
" "	"	+10	87.7
" "	"	30	80.7
" "	"	50	73.8
" "	"	60	70.2
" "	"	157	0
Water†	H ₂ O	0	597.3
"	"	10	591.6
"	"	20	585.9
"	"	30	580.2
"	"	40	574.5
"	"	50	568.9
"	"	60	563.2
"	"	70	557.4
"	"	80	551.5
"	"	90	545.3
"	"	100	539.1
"	"	110	532.6
"	"	120	526.0
"	"	130	519.2
"	"	140	512.1
"	"	150	504.8
"	"	200	463.3
"	"	250	409.7
"	"	300	335.1
"	"	350	213.0
"	"	374	55.3

* Unpublished data

† International Steam Tables (1934)

REFERENCES

- 1 BAHKE, W H., and KAY, W B *Ind Eng Chem* 24, 3 (1932)
- 2 Bureau of Standards, *J of Research* (1932)
- 3 CRAIG, C S Miscellaneous Publication no 97, U S Bureau of Standards (Thermal Properties of Petroleum Products), 1929
- 4 GOODLETT, A H *Trans Inst Chem Eng* 12, 135 (1934)
- 5 MAXWELL, J B *Ind Eng Chem* (May 1932)
- 6 PARKS, G S., and HUFFMAN, H M *Ind Eng Chem* 23, 1138 (1931)
- 7 PARKS, G S., and TODD, S S *Ind Eng Chem* 21, 12 (1929)
- 8 SCHULTZ, J W *Ind Eng Chem* 22, 785 (1930)

ARTICLE

- 9 WATSON, K M Correlation of the Physical Properties of Petroleum

THERMAL CONDUCTIVITY OF GASES, VAPOURS, AND LIQUIDS

By E. S. L. BEALE, M.A., F.Inst.P.

Consultant in Engineering Physics, London

Thermal Conductivity of Gases and Vapours

The experimental data for the thermal conductivity of gases are for the most part available over a very restricted temperature range (in most cases below 100° C), and are often very conflicting at the higher temperatures.

In Table I the experimental values given in the *International Critical Tables* for 0° C have been used in all cases with the exception of steam, for which the data at 100° C were used. The values for the higher temperatures were calculated by means of the following relationship derived from the Kinetic Theory of Gases with the exception of benzene and isopentane, for which the experimental points from the *ICT* were plotted and the lines extrapolated graphically.

The equation is

$$\frac{K_1}{K_0} = \frac{\eta_1 C_{v1}}{\eta_0 C_{v0}}$$

where K_0, K_1 = thermal conductivity at 0° C and t° C,
 η_0, η_1 = absolute viscosity at 0° C and t° C,
 C_{v0}, C_{v1} = specific heat at constant volume at 0° C and t° C

The viscosity data used in the equation are those given in the article on that subject [8]. The specific heat data were taken from *Technical Data on Fuel* [7, 1935] supplemented by data given by Partington and Shilling [5, 1924].

As in the case of absolute viscosity, the thermal conductivity of gases may be taken to be independent of pressure over a fairly wide range.

The figures for the thermal conductivity of gases calculated as described are shown in Table I below, which has been taken from *Technical Data on Fuel* and extended.

Thermal Conductivity of Liquids

The data for the thermal conductivity of liquids are somewhat conflicting and apart from differences in the values obtained at different temperatures by various investigators there is some doubt as to whether the conductivity of certain liquids rises or falls with temperature. There is no possibility of calculating the temperature-conductivity relationship on a theoretical basis, as in the case of gases, so that reliance must be placed on the most trustworthy data available.

In the case of water, for instance, early measurements were quite inconclusive as to whether the conductivity rose or fell with temperature owing to the limited temperature ranges covered. The experiments of Jacob [3, 1920] indicated a steady rise with temperature—see also [4, 1933]—according to the following formula in c g s units

$$k = 0.001325 + 0.00000395t$$

However the more recent work of Schmidt and Sellschopp [8, 1932] makes it appear more probable that the conductivity passes through a maximum at about 130° C. Glycerol appears to be a case where the conductivity rises with rise of temperature. Mercury has practically a constant thermal conductivity. In all other cases the conductivity falls with rise of temperature.

Some thermal conductivities of hydrocarbons based on data given in the *Chemical Engineers' Handbook* are shown in Table II together with an approximate indication of the change with temperature where this is available, but this cannot be regarded as very exact.

The conductivity is given in c g s units. To obtain values in B Th U/(hr) (sq ft) (°F per ft) multiply by 241.9. The thermal conductivity of petroleum oils was correlated by Cragoe [1, 1929] by means of the following empirical equation based on the specific gravity of the oil at 60° F

$$k = \frac{0.28}{d} (1 - 0.00054t) \times 10^{-3}$$

where k = true thermal conductivity in c g s units,
 d = specific gravity of oil at 60/60° F,
 t = temperature in ° C

Values calculated in accordance with this equation are given in Table III.

Several oils have been more recently examined by J. F. D. Smith [6, 1930], which agree satisfactorily with this correlation.

The conductivity of vaseline at 15° C is given as 0.00042 c g s units [2]. The conductivity of solid paraffin is approximately 0.00056 c g s units up to near the melting-point. It then decreases rapidly to that for a petroleum liquid of the same specific gravity.

TABLE I
Thermal Conductivity of Gases

Gas	Thermal conductivity in c g s units and 10 ⁻⁴										
	At 0° C	100° C	200° C	300° C	400° C	500° C	600° C	700° C	800° C	900° C	1,000° C
Hydrogen	380	473	552	624	688	750	811	876	940	1,002	1,067
Nitrogen	54.5	69.7	83.2	97.1	111.0	124.7	138.1	151.6	164.3	176.4	188.2
Oxygen	55.7	73.8	91.7	109.4	126.6	142.8	158.0	172.8	186.1	198.7	210.9
Air	53.3	68.3	82.4	96.4	110.6	124.4	138.1	151.6	164.4	177.0	188.8
CO	51.4	65.7	78.6	91.8	105.2	118.4	131.3	143.6	155.6	166.7	177.5
CO ₂	32.9	51.0	68.9	87.9	105.5	122.5	138.8	154.1	169.0	182.7	196.1
Steam	35.8	51.9	69.1	87.2	106.6	126.9	147.9	169.5	192.2	215.1	238.3
Methane	70.3	114.8	167.5	221.3	281.9	341.7	407.9	470.4	526.2	597.7	661.4
Ethane	43.0	73.9	111.3	152.8	198.2	244.4	289.7	334.5	378.3		
Ethylene	39.2	70.6	105.5	141.9	180.8	220.7	258.9	295.5	332.2		
Benzene vapour	19.7	39.0	62.0	92.2							
Isopentane vapour	27.5	48.0	76.0	(113)							

The thermal conductivity of some miscellaneous liquids is given in Table IV based chiefly on the data from the *International Critical Tables* and the *Chemical Engineers' Handbook*. Where the conductivity is given at 0° and 100° C, this indicates the approximate change in value with temperature

TABLE II

Liquid	Temperature, °C	Thermal conductivity, c g s units
Benzene	30	0 000355
Heptane	4	0 000325
n-Hexane	30	0 000315
"	130	0 000285
Octane	30	0 000335
"	130	0 00030
n-Pentane	30	0 00031
"	130	0 00028
Toluene	30	0 00035
"	130	0 00030
Turpentine	12	0 00029
o-Xylene	22	0 00036
m-Xylene	22	0 000355

TABLE III

t° C	d_{44}^{20}					
	1.0	0.95	0.9	0.85	0.8	0.75
0	0 00028	0 00029	0 00031	0 00033	0 00035	0 00037
100	0 00026	0 00028	0 00029	0 00031	0 00033	0 00035
200	0 00025	0 00026	0 00028	0 00029	0 00031	0 00033
300	0 00023	0 00025	0 00026	0 00028		
400	0 00022	0 00023	0 00024			
Sp gr. API	10.0	17.4	25.7	35.0	45.4	57.2

TABLE IV

Liquid	Temperature, °C	Thermal conductivity, c g s units
Water	0	0 00132
"	50	0 00153
"	100	0 00162
"	130	0 00164
"	200	0 00159
"	300	0 00135
Ammonia	0	0 00115
n-Butyl alcohol	20	0 00039
Isobutyl alcohol	12	0 00036
Castor oil	0	0 00043
Ethylene glycol	0	0 00061
Ethyl alcohol	0	0 00039
"	100	0 00036
Isopropyl alcohol	30	0 00035
Glycerol	0	0 00065
"	100	0 00068
Methyl alcohol	0	0 00050
"	100	0 00047
Mercury	0	0 020
Olive oil	0	0 00043
Sodium chloride brine 12.5%	32	0 00135
" " 25%	32	0 00130
Sulphuric acid 30%	32	0 0012
" " 60%	32	0 0010
" " 90%	32	0 0008
Sulphur dioxide	-15	0 0005

REFERENCES

- 1 CRAIG, C S Mex Publ no 97 US Bureau of Standards (1929)
- 2 *International Critical Tables*
- 3 JACOB, *Ann Physik* (iv), 63, 537 (1920)
- 4 MARTY, L H, and LANG, K C *Proc Phys Soc London*, 45, 523 (1933)
- 5 PARTINGTON, J R, and SHULLING, W G *The Specific Heat of Gases* (1924)
- 6 SMITH, J F D *Ind Eng Chem* 22, 1246 (1930)
- 7 SPIER, H M *Technical Data on Fuel*, 4th ed., 148 (1935)
- 8 SCHMIDT, E., and SELLECHOFF, W *Forsch Gebiete Ingenieurw* 3, 277 (1932)

ARTICLE

- 8 BEALE, E S L Viscosity of Gases

P-V-T RELATIONSHIPS OF HYDROCARBONS

By P. DOCKSEY, B.A.

Anglo-Iranian Oil Company, Ltd

In the course of refining operations hydrocarbon mixtures are subjected to a very wide range of pressure and temperature. One of the first properties which one has to consider when designing equipment to handle material under these conditions, or when analysing the performance of a plant,

P-V-T Relations for Hydrocarbon Liquids.

The P-V-T relationships for hydrocarbon mixtures in the liquid region have been studied by Thiele and Kgy [11, 1933], Jessup [6, 1930], and Watson, Nelson, and Murphy [12, 1936]. The data have been correlated by the

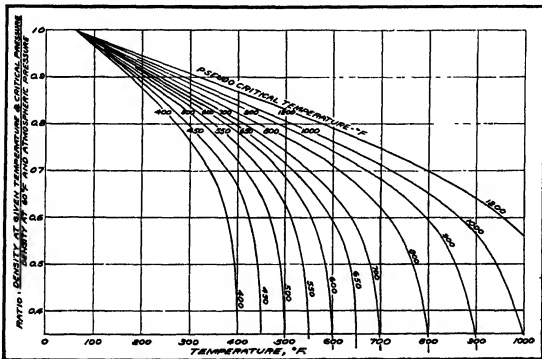

Fig 1 Thermal expansion of hydrocarbons under their critical pressures
(Reproduced by permission from Watson, Nelson, and Murphy, 'Oil and Gas J,' p 85 (Nov 1936))

in order, for example, to determine the time of contact in a reaction zone, or the velocity of vapours in a high-pressure fractionating tower, is the density, in other words the pressure-volume-temperature (p-v-t) relationship of the material. The very wide range of conditions which may occur in practice makes it necessary to know the p-v-t relationships for hydrocarbons

- over a wide range of molecular weight,
- over a wide range of temperature and pressure which should include the liquid and superheated vapour up to pressures well above the critical,
- for mixtures of hydrocarbons as well as for the pure compounds

It is clear that here is a problem which must be solved by means of a generalization, and it is the purpose of this article to describe briefly the methods which are used. We shall first very briefly consider the liquid and mixed vapour-liquid regions, and then at greater length the superheated-vapour region. The latter is by far the most important, not only in its practical applications, but also in the thermodynamical calculations which form the basis of the estimation of fugacity, activation coefficients, and equilibrium constants.

last-named authors who give graphs (Figs 1 and 2), showing the ratio

$$\frac{\text{density at a given temperature and critical pressure}}{\text{density at } 60^{\circ}\text{F and 1 atmosphere}}$$

and the ratio

$$\frac{\text{density at a given pressure}}{\text{density at the critical pressure}}$$

The correlation has been made using the 'pseudo-critical' temperature and pressure, which may be obtained from Fig 12

The experiments on which these graphs have been founded have been made over an extensive range of temperature (up to 800° F) and pressure (up to 1,200 lb per sq in), and on a wide variety of virgin and cracked stocks

The Vapour-Liquid Region.

The calculation of the specific volume in this region is a matter of great difficulty when one is dealing with mixtures, but as material is frequently encountered under these conditions (for instance in so-called liquid phase crackers two phases are very often present), an attempt must occasionally be made to calculate the specific volume, although one is

forced to admit at the same time that the figure obtained is only a very rough approximation

The steps to be taken are as follows

From a knowledge of the mol composition of the mixture under consideration and the employment of the

The Vapour State.

The p - v - t relationship of a substance in the vapour phase is customarily expressed by means of an equation of state, the simplest form of which is that for ideal gases $PV = RT$

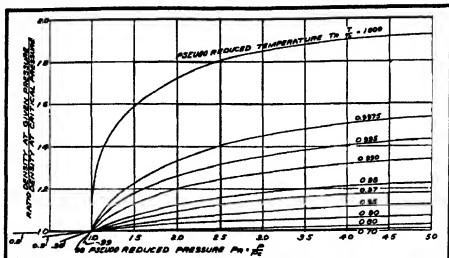

FIG 2 Compressibility of liquid hydrocarbons
(Reproduced by permission from Watson, Nelson, and Murphy, 'Oil and Gas J' p 85 (Nov 1936))

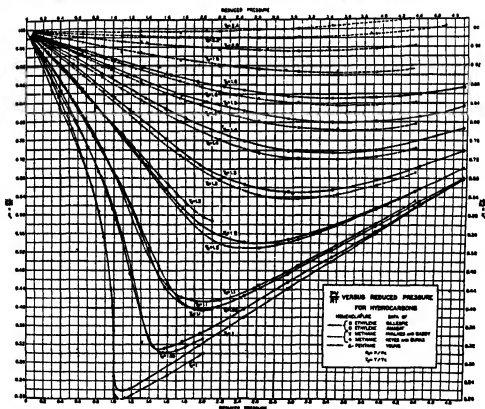

FIG 3
(Reproduced by permission from Lewis, 'Ind Eng Chem' 28, 257 (1936))

equilibrium equations, the quantity and composition of vapour and liquid obtained from unit mass of the mixture at the pressure and temperature under consideration can be calculated. The specific volume of the liquid portion can be determined by the methods given in the previous section, and that of the vapour from what follows.

This simple equation can be applied to actual gases with sufficient accuracy for engineering purposes at comparatively low pressures. At high pressures, and particularly in the neighbourhood of the critical point, it is useless. This has led to the introduction of other equations of state, of which that of van der Waals is probably best known.

This contains two constants which can be calculated from the frequently available or capable of being estimated, is capable of frequent and useful application. It must be realized, however, that in the region of the critical point its accuracy is not high, although it is a vast improvement over the assumption that the law of ideal gases applies.

The van der Waals equation is usually written

$$\left(p + \frac{a}{v^2}\right)(v-b) = RT$$

If the critical data are known, the constants a and b can be

the possibility of deriving the constants from data which are frequently available or capable of being estimated, is capable of frequent and useful application. It must be realized, however, that in the region of the critical point its accuracy is not high, although it is a vast improvement over the assumption that the law of ideal gases applies.

The more accurate Beattie-Bridgman [2, 1927] equation is not of general use to the petroleum technologist since

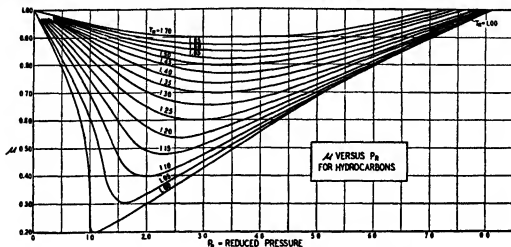

FIG 4

(Reproduced by permission from Lewis, *Ind Eng Chem* '28, 257 (1936))

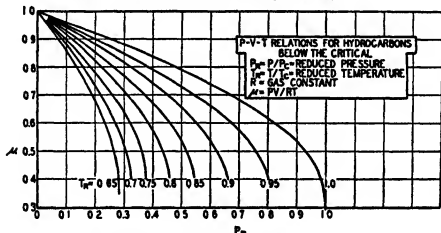

FIG 5

(Reproduced by permission from Lewis, *Ind Eng Chem* '28, 257 (1936))

obtained from the following formulae which are derivable theoretically

$$a = \frac{27R^2T_c^3}{64P_c}$$

$$b = \frac{RT_c}{8P_c}$$

The van der Waals equation can also be established from a knowledge of the p-v-t relations of a substance, and if this is done the constants a and b so obtained may be used to derive the critical data from the formulae

$$v_c = 3b,$$

$$P_c = \frac{a}{27b^2},$$

$$T_c = \frac{8a}{27bR}.$$

Van der Waals' equation, on account of its simplicity and

some p-v-t data are necessary before the constants can be evaluated. Its main value lies in the extrapolation of limited p-v-t data, and in making very precise interpolations. The latter of these operations is one which is performed by the research worker rather than the chemical engineer, while the former can be carried out with sufficient accuracy by the use of compressibility factors plotted under reduced temperature and pressures, as given below.

Generalized Compressibility Factors for Pure Hydrocarbons in the Vapour State. The volume occupied by a vapour at any temperature and pressure P and T may be expressed by the equation $PV = \mu RT$, where μ is the compressibility factor. μ will be a function of P and T , and the problem before us is to find a generalized equation and a graph which will express this relation for all hydrocarbons.

It has been shown that the p-v-t data for pure hydrocarbons may be correlated with reasonable accuracy by

plotting μ against the reduced temperature ($=T/T_c$) and reduced pressure ($=P/P_c$) [3, 1932, 4, 1931]. Data are available for methane [6, 1931, 8, 1927], ethylene [1, 1893], and normal and isopentane [13, 1899, 14, 1894], and these are plotted on Fig 3 [10, 1936].

One implication of this method of plotting should be noted. If it is to hold for a wide range of hydrocarbons, then the value of μ at the critical point will be the same in all cases. Furthermore, μ is equal to 1.0 for all hydrocarbons at a sufficiently low pressure.

Since $P_r = P/P_c$, $T_r = T/T_c$, and $V_r = V/V_c$,

we have

$$\frac{PV}{T} = \mu R,$$

and substituting for P , V , and T in terms of P_r , P_c , T_r , T_c , and V_r , V_c , and rearranging,

$$P_r V_r / T_r = \mu R T_c / P_c V_c$$

At low pressures $\mu = 1.0$, and hence

$$P_r V_r / T_r = R T_c / P_c V_c$$

The right-hand side is called the critical ratio and is a constant for any given substance, and it follows that if a

ethylene. The isometrics corresponding to Fig 4 are shown on Fig 6.

P-V-T Relations for Hydrocarbon Mixtures in the Vapour State.

The isometrics of mixtures of a small number of components whose individual isometrics are known may be calculated by the method proposed by Gilliland [5, 1936];

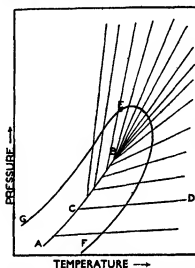

Fig 7 Comparison of pressure-temperature diagram of mixture and pure compound (Reproduced by permission from Kay, 'Ind Eng Chem' 28, 1014 (1936))

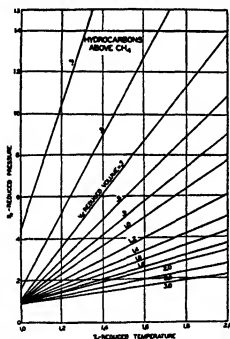

Fig 6 (Reproduced by permission from Lewis, 'Ind Eng Chem' 28, 257 (1936))

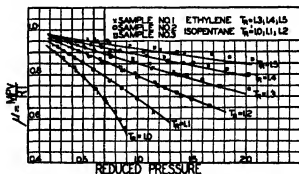

Fig 8 Comparison of plant gases with isopentane and ethylene (Reproduced by permission from Kay, 'Ind Eng Chem' 28, 1014 (1936))

group of substances has a common reduced equation of state they must possess identical critical ratios. The most recent values for the critical constants of hydrocarbons show that the critical ratios for hydrocarbons have a variation of only 12% between the highest and the lowest values, and furthermore if we except the low-boiling, low-molecular weight compounds methane, ethane, &c., the maximum variation from an average value does not exceed $\pm 3\%$. A graph showing μ plotted against reduced pressure and temperature may, therefore, be constructed which will apply to hydrocarbons of more than three carbon atoms with reasonable accuracy. Such graphs are shown in Figs 4 and 5 [3, 1932; 10, 1936]. At temperatures below the critical they have been constructed from the data of Young on isopentane, and at higher temperatures from the data on

10, 1936]. Where accurate values are needed for thermodynamic calculations this method should be used. It is, however, too laborious for general use, particularly for mixtures containing large numbers of components.

It is by no means certain that the data of Figs 3, 4, and 5 can be utilized to determine the compressibility factor μ for mixtures. One difficulty lies in the definition of the critical point which is ambiguous in the case of mixtures owing to the occurrence of the phenomenon of retrograde condensation. Fig 7 shows the pressure-temperature diagram for a pure hydrocarbon whose vapour pressure line is ACB . The boundary curve for a hydrocarbon mixture GEF is also shown, E being the critical point, G lying on the bubble-point line and F on the dew-point line. The pure hydrocarbon has been so chosen that outside the boundary curve the isometrics of the pure hydrocarbon fit those of the

mixture as closely as possible. The isometrics of the two materials will not exactly coincide, but experiment shows that there will be fair agreement. Now if, in calculating the reduced temperature and pressure for the mixture in order to

method of choosing the point B_c or as it may be called the 'pseudo-critical point' of the mixture, can be decided by experiment. This has been done by Kay [7, 1936], for a variety of mixtures including plant gases and narrow

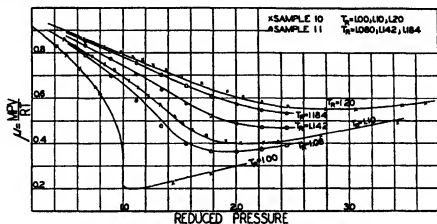

FIG 9 Comparison of liquid-gas mixtures with isopentane
(Reproduced by permission from Kay, 'Ind Eng Chem' 28, 1014 (1936))

Physical Data on Stocks Studied Gases

Sample no	Mol wt	Podbielniak analysis							Total mo		
		Air	C ₁	C ₂ =	C ₃	C ₃ =	C ₄	C ₄ =	C ₅	C ₄	C ₅
1	37.7*	0.70	7.06	5.10	24.90	22.05	30.92	5.85		3.42	
2	39.4*	0.58	0.96	2.35	25.88	19.50	47.11			3.62	
3	46.0*		0.55	2.16	0.83	17.26	64.42	5.75	6.23	2.43	3.08
10a					19.24	23.80	52.91			1.34	

* Calculated from density measurements

Liquids

Sample no	Description	Mol wt	Sp gr at 60°F	ASTM distillation % evaporation at °F						
				IBP	10	30	50	70	90	FBP
4	Straight-run naphtha from Mid-Continent crude	86	0.694	143	150	154	158	162	170	198
5	Cracked distillate from Mid-Continent crude	109	0.755	42	146	240	288	322	358	398
6	Cracked gasoline from Gulf Coast crude	107	0.771	144	188	221	250	278	318	374
7	Straight-run distillate from West Texas crude	98	0.702	190	191	192	193	193	193	195
8	Cut from straight-run distillate, Mid-Continent crude	104	0.756	219	220	221	222	223	225	231
9	Cut from straight-run distillate, Mid-Continent crude	111	0.741	240	243	243	243	244	244	262
C	Straight-run distillate from Mid-Continent crude	110	0.750	211	230	245	258	272	295	326

Liquid and Gas Mixtures

Sample no	Mol wt	
10	77	Mixture of 89.9% by wt of sample 4+10.06% by wt of sample 10a
11	81.5	Mixture of 26.62 mol % ethane+73.3 mol % n-heptane

obtain values of μ from Figs 4 and 5, we use as the critical constants the values corresponding to B_c , the critical point of the pure compound, rather than E_c , the critical point of the mixture, we shall be able to obtain values of μ which will be accurate save in the interior of the boundary curve. The

and wide-boiling distillates, the experimental data being compared with that for ethylene or isopentane, whichever was the more appropriate. The comparison is shown on Figs 8-11, and the composition of the mixture is as above.

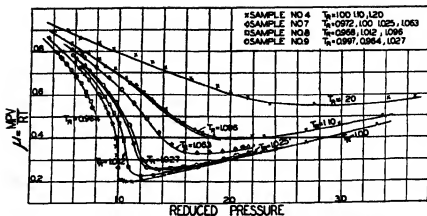

FIG 10 Comparison of narrow-boiling-range distillates with isopentane
(Reproduced by permission from Kay, 'Ind. Eng. Chem.' 28, 1014 (1936))

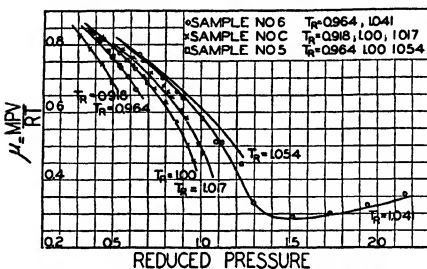

FIG 11 Comparison of wide-boiling-range distillates with isopentane
(Reproduced by permission from Kay, 'Ind. Eng. Chem.' 28, 1014 (1936))

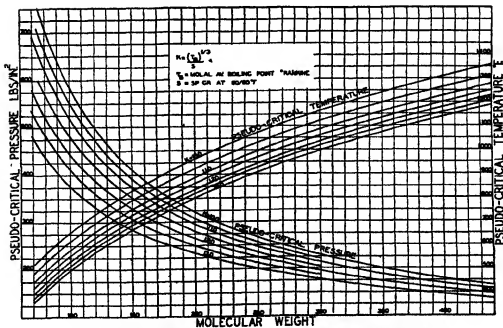

FIG 12 Pseudo-critical temperatures and pressures of hydrocarbon mixtures
(Reproduced by permission from Kay, 'Ind. Eng. Chem.' 28, 1014 (1936))

It will be observed that in the case of all these mixtures of widely varying properties it has been possible to choose a pseudo-critical temperature which has allowed the experimental data to be well correlated with the pure hydrocarbons.

The pseudo-critical temperature and pressure as obtained from the above experiments have been correlated with the

U O P characterization factors $K = (T_p)^{1/3}/S$, where T_p is the molar average boiling-point $^{\circ}$ Rankine, and S is the specific gravity at 60° F. For light hydrocarbon mixtures below hexane, K may be obtained from the equation

$$K = 14.3 - (M - 30)^{0.0288}$$

where M is the average mol wt of the mixture

The correlation is shown on Fig 12

REFERENCES

- 1 AMAGAT E H *Ann Chem Phys* **29**, 68 (1893)
- 2 BEATTIE, J A., and BRIDGMAN O C *J A C S* **49**, 1665 (1927)
- 3 BROWN, G G., SOUDERS, M., and SMITH, R L *Ind Eng Chem* **24**, 513 (1932)
- 4 COPE, J O., LEWIS, W K., and WEBER, H C *Ind Eng Chem* **23**, 887 (1931)
- 5 GILLELAND, E R *Ind Eng Chem* **28**, 212 (1936)
- 6 JENSEN, R S *Bur Stand J Res* **5**, 985 (1930)
- 7 KAY, W B *Ind Eng Chem* **28**, 1014 (1936)
- 8 KVALNES, H M., and GADDY, V L *J A C S* **53**, 394 (1931)
- 9 KEYES, F G. and BURKS, H G *J A C S* **40**, 1403 (1927)
- 10 LEWIS, W K *Ind Eng Chem* **28**, 257 (1936)
- 11 THEELE, E W., and KAY, W B *Ind Eng Chem* **25**, 894 (1933)
- 12 WATSON, K M., NITSON, E F., and MURPHY, G B *Oil and Gas J* p. 85 (12 Nov 1936)
- 13 YOUNG, S *Z. physik Chem* **29**, 193 (1899)
- 14 ——— *Proc Phys Soc* **13**, 602 (1894)

DETERMINATION OF CRITICAL TEMPERATURE AND PRESSURE OF PETROLEUM FRACTIONS

By LOUIS C. ROESS, E E , Ph D.

Beacon Laboratory of the Texas Company

INTRODUCTION

COMPREHENSIVE critical temperature and pressure data for petroleum fractions are of real value in the estimation of P-V-T relations [3, 1931] and in the study of petroleum refining operations where knowledge of phase conditions may be important. The critical volume is not so important, because its value varies over only a small range, and can be estimated from a knowledge of the critical pressure and temperature.

In connexion with the use of critical temperature and pressure data in estimating P-V-T relations, an important article by W B Kay [6, 1936] should be mentioned. Kay shows that, for hydrocarbon mixtures having a fairly wide boiling range it is not accurate to use the true critical data to obtain the reduced temperature and pressure values necessary to apply the method of Cope, Lewis, and Weber [3, 1931]. Instead, a pseudo-critical point, having no real existence, is defined by Kay such that the reduced variables obtained by its use do predict P-V-T relations in agreement with experiment. This pseudo-critical point lies within the border curve of the mixture, and Kay gives a method of estimating it, using the molecular weight and the Watson and Nelson characterization factor [11, 1933].

Since the pseudo-critical point differs from the true critical point only because the mixture has a finite boiling range, it should be possible to estimate it by applying a correction depending on the boiling range to the true critical point, in a way similar to that in which the molal average boiling-point is obtained from the volumetric average boiling-point.

Another estimate of the pseudo-critical point can probably be obtained from a knowledge of the border curve of the fraction in the critical region. This information can be obtained by the method described in this article.

In the past, the critical constants have been determined by means of a static method in which the substance is held at its critical point for an appreciable time. It is this unavoidable feature of the static method which causes its failure when applied to a substance, such as a gas oil, which decomposes at its critical temperature. In general, due to this decomposition or cracking, the observed critical temperature is less than the true value for the original substance, while the observed critical pressure is greater than the true value. Because experimental conditions prevent the measurement of the amount of decomposition, it is not possible to determine just what substance actually is being measured. The application of this method to petroleum fractions is therefore limited to those having critical temperatures below 850° F., when only the critical temperature is measured, and to those having critical temperatures below 700-750° F., when all the critical constants are being measured.

The most important published work on the critical temperature of petroleum fractions is that of Eaton and Porter [4, 1932]. Other workers who have published critical temperature data are Zeitfuchs [13, 1926], McKee and Parker

[7, 1928], McKee and Szayna [8, 1930], Weir and Eaton [12, 1932], and Bahlke and Kay [1, 1932].

All these critical temperature data have been obtained by a static method similar to that of Eaton and Porter. In their method a 5-7 mm pyrex tube about 1 in long is filled one-third full of oil and then sealed off. A thermocouple is then fastened to the outside of this capsule, and the whole is placed in a suitable furnace, in which it is heated to the critical temperature, the oil being thoroughly stirred by rotating the capsule. The critical temperature is taken as that at which the oil meniscus vanishes somewhere near the middle of the capsule. This last condition is fulfilled by filling the capsule with the proper amount of oil, the result being unaffected by a plus or minus 10% variation in the cold oil volume.

Using these data and that of others on pure compounds, Eaton and Porter developed a correlation between the critical temperature, the ASTM 50% point, and the density. This correlation has been used extensively by the petroleum industry. The present work shows that it predicts critical temperatures correctly up to about 800° F., above which the predicted critical temperatures are too low, as would be expected from the fact that appreciable cracking, with consequent reduction in the critical temperature, must have occurred during the long contact times (60-120 sec.) at cracking temperatures, which are necessary for measurements by the static method.

In the initial critical temperature investigations carried out in this laboratory a static apparatus similar to that of Eaton and Porter was used. It was found that almost any result could be obtained for the critical temperature of any oil which cracked appreciably at its critical temperature, simply by varying the length of time taken to heat the oil from 750° F. to its critical temperature. If this time was short, the thermocouple heated more rapidly than the oil, giving too high an apparent critical temperature, while if the time was long the oil cracked, giving too low an apparent critical temperature. These statements may be verified by referring to Fig. 1, which shows the effect of time above 750° F. on the observed critical temperature. The points represented by circles are values obtained with different capsules, while all the other points were obtained by maintaining the oil near its critical temperature and taking readings at intervals. Thus, on Fig. 1 the squares, triangles, crosses, and plus signs represent data obtained in this manner on four different capsules. One reason for the large spread of the data is that no effort was made to keep the temperature from run to run exactly the same between readings, so that the different runs are not strictly comparable on a time basis. The predicted critical temperature for this oil is 900° F. according to the correlation proposed in this article.

The difficulty with the static method just described and exemplified cannot conceivably be overcome by modifications in the apparatus, since even if the thermocouple temperature could be made the same as the oil temperature

for rapid heating rates, the rate of temperature rise (the range from 750° to 900° or 1,000° F must be traversed in less than 1 second) necessary to prevent cracking could not possibly permit an accurate observation or temperature measurement.

Very little data on the critical pressure of petroleum fractions have been published. Bahlke and Kay [1, 1932] have measured the critical pressure of a gasoline and a

indicator of the critical point. Obviously, this change cannot be used when the oil is flowing. To determine what phenomena could be used to identify the critical point during flow, a preliminary experiment, in which flowing pentane was heated under pressure in a long pyrex tube, led to the thought that the critical point could be identified by means of a fine mist which could be made to appear

and disappear by varying the pressure up and down through the critical pressure. Later work showed that this phenomenon was not sufficiently definite, particularly for wide-boiling mixtures, and a much more certain indicator was used.

This indicator was a very definite colour change in the flowing oil accompanying vaporization in the critical region. Ordinarily, when viewed by transmitted light, the liquid colour was yellowish, changing to a yellowish-grey fog as the pressure was lowered. In the critical region, however, the appearance of this fog was accompanied by a very distinct red colour just before it completely filled the tube. This red colour was unmistakable and occurred for every oil examined. In the case of narrow-boiling stocks it was visible over a temperature of 1°

or 2° F, while for some blended stocks a wide boiling range it was visible over a 10° F temperature range. The middle of this range was taken to be the critical temperature. The upper and lower boundaries were quite sharply defined in every instance.

This identification of the critical point with the red colour change is in close accord with a similar phenomenon observed when using the static method. The vanishing of the meniscus is always accompanied by a fog or mist formation showing colour change. This phenomenon of light scattering is called 'critical opalescence', and has been taken as an indicator of the critical point by some observers, although others claim that critical temperatures measured in this way differ by a fraction of a degree from those obtained by observing the disappearance of the meniscus. Even if this difference exists, the resulting error is much smaller than the other experimental errors.

The recent development of the large-size Polaroid polarizing screens makes it probable that other methods of determining the critical point can be developed, based on the maximum depolarization of scattered light at the critical point. It is also possible that the greatly increased intensity of the Tyndall effect could be used. It may be necessary to develop such new methods of determining the critical point, based on the above principles, in order to measure mixtures containing gas, and hence having a very wide boiling range, since the temperature range over which the red opalescence persists appears to be roughly proportional to the boiling range. Work along these lines is now being undertaken.

Since petroleum fractions are mixtures of pure substances, they therefore possess, in addition to a critical point, a point of maximum temperature and a point of maximum pressure. In order to eliminate any doubt as to which of these three points is being measured by the flow method, this phase of the investigation merits detailed

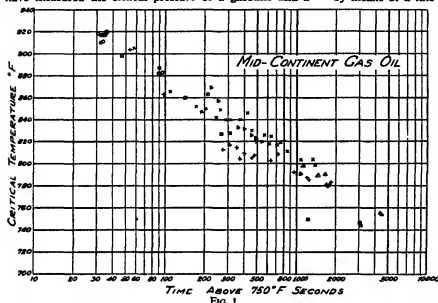

naphtha, employing a static method in which the sample is heated in a glass or quartz tube sealed at one end, the pressure developed being transmitted to a gauge by means of mercury. The maximum temperature at which accurate measurements can be made is even less with the critical pressure determination than with the critical temperature determination because more time is required. It is certain that this method is not accurate above 700–750° F.

The almost total absence of critical pressure data, and the lack of critical temperature data in the high temperature region, emphasized the need for a new method of measurement which would eliminate the effect of cracking. This necessity suggested measuring the critical temperature and pressure by a flow method, since previous experience (unpublished) with cracking equipment had shown that it was possible to heat the oil to its critical temperature while flowing, without the occurrence of appreciable cracking.

It is clear that a flow method, in which the oil is heated very rapidly to its critical temperature, would eliminate the faults of the static method. To make a flow method successful, two problems have to be solved.

(1) A chamber in which the flowing oil can be observed visually at high temperatures and high pressures has to be developed.

(2) A positive method of identifying the critical point of the flowing oil has to be devised.

A method of measuring critical temperatures and pressures on these lines has been developed by the author [10, 1936] and used to determine the critical data for over a hundred petroleum fractions. This method is described below, but the original paper should be consulted for further details of the results obtained.

The Critical Phenomena

The static method uses the vanishing of the meniscus between the liquid and vapour phases of the oil as an

treatment The border curves shown on Fig 2 will illustrate the question at issue A border curve is the locus of the points in the pressure-temperature plane which separate the homogeneous state (liquid or vapour alone) from the heterogeneous state (liquid and vapour together) On Fig 2 the boiling curve, ic is the locus of points at which the first vapour trace appears, or the last disappears, is represented by a solid line The dew curve, or locus of points at which the first trace of liquid appears, or the last trace disappears, is represented by a broken line These two curves meet in the critical point C P is the point of maximum pressure, while T is the point of maximum temperature In general, P and T do not coincide with C except for pure compounds

An examination of the border curve without regard to the type of phenomena which identify the critical point C could give rise to the suspicion that either the point of maximum pressure P , or the point of maximum temperature T , since these are outstanding points, is being mistakenly identified with the critical point Definite experimental evidence was obtained that the critical point was observed, and not the point of maximum pressure or maximum temperature, since it was found possible to follow the border curve of wide boiling blends in the critical region While for wide boiling blends the difference between the maximum pressure and the critical pressure never exceeded 10 lb per sq in, the point of maximum temperature differed from the critical point by as much as 50° F., and 200 lb per sq in

The validity of the results obtained by the flow method has been confirmed also by comparison with those obtained by the static method, when the type of stock permitted For example, the critical temperature of a Mid-Continent kerosene was found to be 759° F by a static method and 758° F by the flow method.

Flow Method

Apparatus.

As a result of the preliminary work mentioned above, an apparatus capable of handling gas oils was constructed, the main features of which were as follows The oil under pressure from a nitrogen cylinder was first heated to 750° F in several coils immersed in lead baths and then rapidly raised to its critical temperature in another lead bath containing 15 ft of 0.072-in ID steel tubing Observation of the critical phenomena was made in a special quartz chamber inserted at this point, after which the oil was cooled to room temperature in a water-bath and the flow rate measured

After two types of gauge glasses [9, 1934] had been tried, the final form of observation chamber adopted is shown in Fig 3. A fused quartz cylinder 3½ in long, 2 in in diameter, and having an axial hole 5 mm in diameter was held between the invar ends of a self-aligning compression yoke using ball-cone seats, the quartz-invar joints being gasketed with copper-asbestos rings (sparking plug type) The ends of the quartz were highly polished and coated

with powdered graphite to allow mutual slipping of the gasket and the quartz, eliminating shearing stresses Invar end-pieces were used under the mistaken idea that the relative expansion between them and the quartz would be minimized It was only later that the limited temperature region over which the unusual expansion property of invar holds true was realized

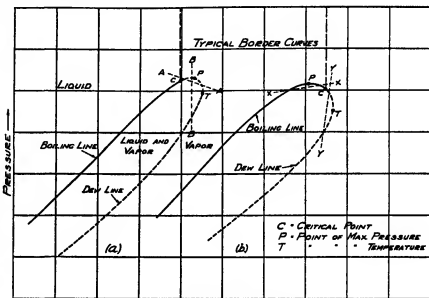

FIG 2

Heat loss from the oil flowing through the quartz was reduced by a helical nichrome heating-coil threaded through mica spacers fastened to aluminum posts separating two asbestos rings

While it was found an easy matter to burn out any coke deposition on the inside of the quartz cylinder, the deposition of iron oxide which results from burning out the steel tubing made it necessary to dismantle the chamber and to clean it after every three to five runs This was a very simple task, since what iron oxide cannot be simply swabbed out was readily dissolved in hydrochloric acid without injury to the quartz.

During the course of the measurements the fused quartz cylinder developed a number of incipient conchoidal fractures at each end, extending from near the central hole diagonally outwards into the quartz One of these was about ¼ in long These incipient fractures originated under the copper-asbestos gaskets, and seem to have first appeared when the gaskets were quite flat, without much yield For some time it was feared that the quartz would break, but the use of new and yielding gaskets has prevented increase in the size and number of the incipient fractures To prevent these fractures a frequent renewal of the gaskets is desirable

The complete apparatus can be visualized by reference to the flow diagram Fig 4 and the photograph Fig 5 The flow diagram is self-explanatory The valve numbers on the flow diagram and the photograph are identical

Four lead-immersed heating coils supply the heating capacity necessary when flow rates of 35,000–50,000 ml per hour are used to prevent cracking of the oils having critical temperatures above 950° F In order to measure critical temperatures up to 1,000° F., a 10 kw heating coil



FIG. 5

was necessary in the lead bath surrounding the capillary coil. Even greater heating capacity in this bath will be necessary if still higher temperatures are to be measured.

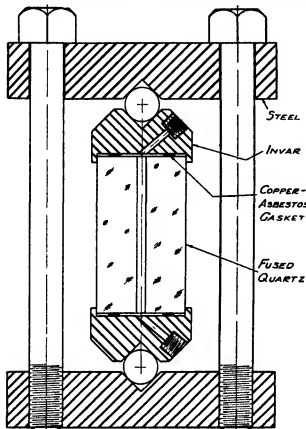

QUARTZ OBSERVATION CHAMBER

FIG 3

An important feature of the apparatus is the location of the forged steel flow control valve, 12, between the observation chamber and the cooling system. The presence of this valve in the hot oil line has made possible accurate and steady flow control, completely eliminating foaming and other troubles caused by gas which were experienced when the flow control valve was in the position of the outlet valve, 13.

The charging cylinders, each having a capacity of about 10,000 ml., were made long and narrow to prevent appreciable solution of the high-pressure nitrogen in the oil during the 15-30 min required for a run. The cylinders were wound with steam coils and insulated to allow wax stocks to be charged.

Temperature Measurement The oil temperature was measured by means of two $\frac{1}{8}$ -in iron-constantan pencil thermocouples welded in the tubing leading to the chamber, with their tips almost exposed at the invar-quartz junction. The shank of each thermocouple is surrounded by flowing

oil for about 3 in from the tip to the weld, minimizing conduction errors. A Leeds and Northrup Type K Potentiometer was used to measure the thermocouple $e m f$.

It was found that at high temperatures a temperature gradient of 5-10° F existed along the observation chamber despite the action of the heating coil mentioned above. It is believed that this gradient was due to heat losses from the upper invar end-piece, which cannot be readily insulated in the present design. Whenever this gradient existed an average of the two temperatures was taken. It is not believed that an appreciable error was introduced by it, although it should be eliminated by better design.

Pressure Measurement The oil pressure was measured by means of a 1,000 lb per sq in gauge equipped with a 10-in dial calibrated in intervals of 10 lb.

Contact Times The flow rates were measured by observing the amount of oil from the outlet valve, 13, which ran into a graduated cylinder in 10 sec. An approximate idea of the time of contact at the highest flow rate can be obtained from the following figures for the cold contact times for various parts of the apparatus. The last pre-heater coil has 12 ft of 0.216-in ID tubing, while the capillary coil has 15 ft of 0.072-in ID tubing. Using these figures, and assuming a flow rate of 45,000 ml per hour, the following cold contact times can be calculated:

1	In last preheater	6.91 sec
2	In capillary coil	0.960 "
3	In quartz chamber	0.14 "
4	In tubing containing thermocouples, one end only	0.233 "

From the values for the critical densities of pure hydrocarbons one can estimate a hot contact time of from one-half to one-third of the above figures.

Procedure.

A brief description of the procedure adopted may be of interest. For high-temperature runs three observers were necessary—one to read the flow rate, one to operate the potentiometer which measured the two thermocouple $e m f$'s, and one to observe the critical phenomena and

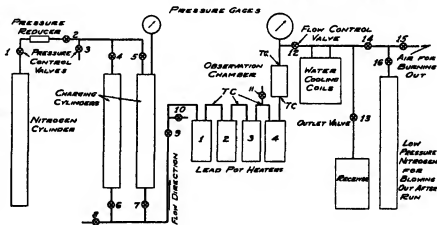

FLOW DIAGRAM FOR CONTINUOUS FLOW
CRITICAL CONSTANT APPARATUS

FIG 4

control the pressure and temperature accordingly. For oils not exceeding 850° F in critical temperature the flow rate could be estimated sufficiently well by the eye, eliminating one observer.

The lead baths were first brought up to temperature,

which, of course, varied with the oil charged. For critical temperatures below 750–800° F the first two baths were not used. For higher critical temperatures the outlet temperature of bath 3 was adjusted to lie in the range 750–800° F, the temperatures of baths 1 and 2 being adjusted to give about a 250° F increase per bath. The temperature of bath 4 was adjusted to be slightly over the expected critical temperature, except in the case of high temperatures, when bath 4 was limited to 900° F at the start of the run, since otherwise there was danger of coking up the observation chamber before a sufficiently high flow rate could be established.

With valve 9 closed, the nitrogen pressure on the charging cylinders was raised to 200 lb, valve 9 opened, and valve 12 adjusted to give the desired flow rate. The nitrogen pressure was then raised until the flowing oil was in the liquid state in the observation chamber and the oil temperature gradually raised to the critical point by increasing the temperature of bath 4. It was found most convenient to raise the pressure above the critical, and then to read pressure and temperature simultaneously as the pressure slowly fell through the critical region. The general idea of the observations may be described as a superposition of a fairly rapid pressure variation up and down through the critical region and a slow temperature rise and fall in this region. The top thermocouple was read first, followed as rapidly as possible by the bottom couple. The temperature interval between the two couples was kept below 10° F by controlling the current in the heating coil surrounding the quartz chamber, and was generally considerably less.

From runs at high temperature and medium flow rates it was found that the amount of cracking had a pronounced effect on increasing the observed critical pressure. Therefore, this effect was used to determine whether cracking was occurring at any given flow rate, by observing whether any fall in critical pressure followed a considerable increase in flow rate. If no fall or other change occurred, it was assumed that the effect of cracking was entirely negligible. We can safely say that the critical temperatures measured were not appreciably affected by any cracking up to the highest values measured, but the critical pressures of oils with the highest critical temperatures are somewhat uncertain, since for these it was not possible to further increase the flow rate and at the same time maintain the temperature.

Critical Temperature

Critical temperature and pressure data have been obtained by the author on over 100 petroleum fractions. The data for these fractions are given in full in the original paper [10, 1936]. Most of these fractions were made up by blending eight base stocks, viz:

1. Mid-Continent straight run gasoline
2. Naphthene base straight-run gasoline
3. Cracked naphtha

4. Mid-Continent kerosene.
5. Mid-Continent gas oil.
6. Naphthene base gas oil.
7. No 1 cycle gas oil.
8. No 2 cycle gas oil.

In addition, data were obtained on various gas oils from naphthene base, Mid-Continent, and Pennsylvania crudes, as well as blends of a solvent-refined S A E 20 motor oil with kerosene.

Stocks containing gas and the products from cracked gas oils cannot be used in the present apparatus, nor can measurement on stocks having critical temperatures higher than 1,000° F be made.

The critical temperatures measured range from 550 to

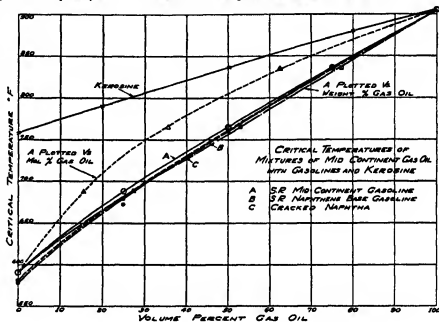

FIG 6

1,000° F, and the critical pressures from 250 to 700 lb sq in absolute.

Fig 6 shows the critical temperature of various two-fraction blends, plotted against volume per cent, of the heavier fraction. In most cases the critical temperature deviates slightly from a linear function of volume per cent, being convex upward. On Fig 6 the critical temperature is also plotted against weight per cent, which gives a more nearly linear relationship, and against mol per cent, which gives a much greater deviation from linearity.

Using the data from this investigation, as well as the published data for the eleven pure hydrocarbons [5, 7, 1928], a correlation of critical temperature with specific gravity 60/60° F and volumetric average boiling-point (V A B P), was developed. The V A B P is defined here as the arithmetic mean of the temperatures at the 10, 30, 50, 70, and 90% points of an A S T M distillation.

It was found that only the V A B P, and not the A S T M 50% point or the molal average boiling-point (M A B P) [11, 1933], could possibly fit the data on blended stocks. The reasoning involved is the following: Suppose that for non-blended, relatively narrow boiling stocks a critical temperature correlation with any of the average boiling-points could be developed, as is probably true. Then consider, from the curves on Fig 6, how the blends will fit in. Since the blends have a wide boiling

range which is not completely filled in with all fractions from light to heavy, it is clear that the 50% point will not be an approximate mean boiling-point for them. It has been found by trial that the V A B P will form a satisfactory correlation variable, since their critical temperatures vary approximately linearly with the volume per cent. On the other hand, it is equally clear that the M A B P will not form a satisfactory correlation variable, since the M A B P for the blends (being equal to the V A B P minus a quantity increasing with the boiling range) will fall considerably below the necessary linear variation with the volume per cent. For normal stocks, for which the M A B P and the V A B P differ but slightly, either can be used satisfactorily.

The specific gravity and V A B P were combined in the same way that Eaton and Porter combined the specific gravity and 50% point to define a quantity

$$a = (\text{specific gravity, } 60/60^\circ \text{ F}) (\text{V A B P} + 100)$$

By fitting a second degree equation in a to the observed data on 95 petroleum fractions and 11 pure hydrocarbons, by the method of least squares, the following correlation was obtained

$$T_c = 202.7 + 1.591a - 6.29 \times 10^{-4} a^2 \text{ degrees F}$$

Fig 7 shows the data and the equation. The correlation of Eaton and Porter is also shown (assuming for the purpose equality of 50% point and V A B P). The deviation between the two is marked at temperatures above 850° F, showing the result of cracking in lowering the critical temperatures determined by the static method. Eaton and Porter's data, as well as two points obtained by Bahlke and Kay [1, 1932], are plotted also. The correlation of Watson and Nelson [11, 1933] predicts critical temperatures which are considerably lower than those observed by the author to much the same extent as does that of Eaton and Porter. Furthermore, since it is based on the molal average boiling-point, Watson and Nelson's correlation shows even greater discrepancies when applied to the blended fractions.

The maximum deviation of the author's experimental points from the calculated curve is 18° F, while the root mean square deviation is 6.5° F, omitting the points marked with an asterisk for which the distillation data were very doubtful.

The probable error of the critical temperature correlation has been calculated by the method described by Birge [2, 1932] for two points $a = 400$ and $a = 600$, corresponding respectively to $T_c = 737^\circ \text{ F}$ and $T_c = 933^\circ \text{ F}$. The result is plus or minus 0.55° F at $a = 400$ and plus or minus 0.72° F at $a = 600$. It is clear that the difference between the root mean square deviation of 6.5° F and the probable error of less than 1° F is due to the large number of observations involved.

It is not claimed that the absolute accuracy of the measured critical temperatures is as small as 1° F, but an estimated accuracy of plus or minus 4° F appears justifiable.

The critical temperature correlation equation is plotted in a more useful form against the V A B P and the A P I Gravity on Fig 8.

When the critical temperature of an oil is too high to be measured directly, it is possible to approximate to it by measuring the critical temperature of several different mixtures of the oil and another oil with a lower critical temperature, and then extrapolating the curve so obtained to 100%.

Critical Pressure

Fig 9 shows the critical pressure of various two-fraction blends plotted against volume per cent of the heavier fraction. It will be observed that there is a distinct maximum in these curves, which is sharper and higher the greater the separation between the mean boiling-points of the blended fractions. A similar behaviour has been reported in the literature for binary mixtures of many pure compounds [5].

A correlation between the critical pressure, the critical temperature, the molecular weight, and the slope of the A S T M distillation curve based on van der Waals' equation [3, 1931] has been worked out by the author. The equation used is

$$P_c = \frac{AT_c}{M}$$

in which

P_c = critical pressure (lb per sq in abs),

T_c = critical temperature (° C),

M = molecular weight,

A = a function of the slope of the A S T M distillation curve and of the type of fraction.

The following equations for A were developed by fitting straight lines to the data by the least squares method.

For virgin gas oils, kerosene, and Bahlke and Kay's naphtha, a total of 18 measured points

$$A = 44.8 + 2.02 \text{ slope} \quad (1)$$

For gasolines, including straight-run, cracked naphtha, kerosene-cracked naphtha blends, and Bahlke and Kay's gasoline (8 points)

$$A = 47.2 + 3.77 \text{ slope} \quad (2)$$

For all other blends (24 and 45 points, respectively)

$$A = 43.7 + 3.76 \text{ slope} \quad (\text{slope} < 4.3), \quad (3)$$

$$A = 21.2 + 8.76 \text{ slope} \quad (\text{slope} > 4.3) \quad (4)$$

The molecular weights were estimated by the use of Watson and Nelson's correlation [11, 1933], and the probable errors in A were found to vary from about 1% for equation (2) to about 2% for equation (4). The degree of correlation obtained was shown graphically [10, 1936].

It would be desirable if a simple correlation between critical pressure and only two other variables, such as slope and some average boiling-point, could be developed. This does not seem possible, since the density enters into both the critical temperature and the molecular weight in an important way. For a given V A B P the critical temperature increases and the molecular weight decreases as the density is increased, so that their ratio is even more sensitive to density change than is either of them. Therefore, if the above correlation be considered significant, the critical pressure must be considered to depend on at least three variables, which makes it impossible to plot it directly. No improvement is obtained if the M A B P is used.

The critical pressure correlation based on van der Waals' equation is usable only when it is known which equation fits the particular fraction in question. Since the selection of the proper equation is often uncertain, a new critical pressure correlation has been developed by J R Keith [10, 1936]. It uses three variables, namely, the A S T M slope, the M A B P, and the Watson and Nelson characterization factor [11, 1933], which are directly computable from readily measured properties of the fraction. The A S T M slope is defined as one eightieth of the difference between the temperature at the 90% and 10% points on the A S T M distillation curve.

PHYSICAL AND CHEMICAL PROPERTIES

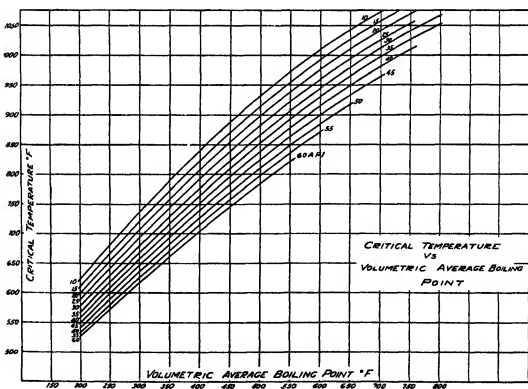
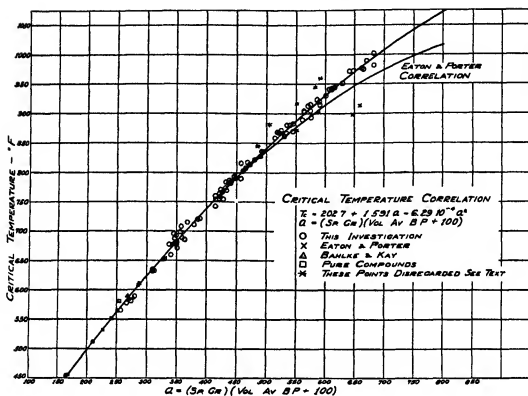

Fig 10 shows this correlation for distillate stocks having a characterization factor X of 11.8. If the stock in question has a characterization factor different from 11.8, its critical pressure is obtained from that given by Fig 10 by means of the equation

$$P_c \text{ (corrected)} = P_c \text{ (Fig 10)} - 95(X - 11.8)$$

The correlation was obtained by eliminating the effect of one of the above variables at a time, and determining

that further consideration of these correlations, when more critical pressure data have been obtained, will lead to more satisfactory methods

Problems Requiring Further Investigation

There are a number of problems connected with critical constants on which the apparatus developed by the author is not able to provide information

- 1 The determination of critical volume. This problem

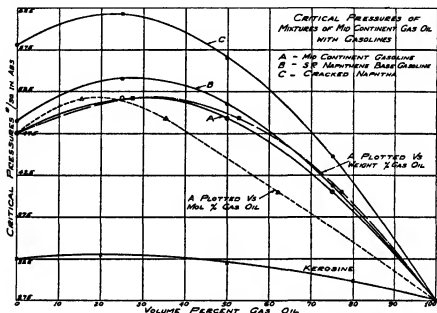

Fig 9

directly the relationship between the remaining ones. It has also been extended to zero slope, i.e. to include pure compounds as shown in Fig 10.

The following table gives a comparison of the observed critical pressures of five fractions and those predicted by (1) the Watson and Nelson [11, 1933] method, (2) the correlation based on van der Waals' equation, and (3) the new correlation.

Ref Number	Oil	1418 Mid Cont gas oil	1418 Naph- thene base gas- oil	1453 Naph- thene base gas- oil	1454 No. 1 cycle gas oil	1507 50% N B gasoline + 50% No. 2 cycle gas oil
T_p , °F		903	942	578	941	816
Mol wt (W and N)		237	241	110	200	146
10% point		500	517	198	442	227
M.A.B.P.		554	579	247	528	381
P_c obs (lb per sq in, abs)		275	295	490	399	607
P_c calc (W and N)		400	450	500	550	900
P_c calc (Van der W)		281	286	495	388	605
P_c calc (new)		248	277	495	421	635

It will be seen that the Watson and Nelson prediction is entirely unsatisfactory except for the gasoline. The new correlation predicts moderately well, while the van der Waals' correlation shows excellent agreement, since in these examples no question arises regarding the choice of the equation giving A .

While none of the correlations has been found to be entirely satisfactory in its accuracy of prediction, it is hoped

seems to be a difficult one to solve, since it requires measurement not only of the cold flow rate, but also the flow velocity at the critical point. Certainly a great amount of research would be necessary to solve it.

2 Measurement of the critical temperature and pressure as a function of the extent of cracking. For this purpose it will be necessary to quench the oil immediately after it has passed through the observation chamber, which is not possible without the use of pumps. It is not certain how much effect cracking will have on coking up the observation chamber, but it seems probable that considerable difficulty would be experienced from this cause.

3 Measurement of the critical temperature and pressure of mixtures containing gases. This problem can be attacked quite easily with a relatively simple modification of the apparatus to allow charging stocks containing gas under pressure.

4 Measurement of critical temperatures higher than 1,000° F. This problem can be solved by increasing the flow velocity and the heating capacity. The flow velocity can be increased by using higher flow rates and somewhat smaller capillary tubing in the last lead pot. A considerable increase in heating capacity, particularly of the last lead pot, would be necessary to handle higher flow rates. A desirable but not absolutely necessary change would be a reduction in the inside diameter of the fused quartz cylinder of the observation chamber.

5 The measurement of the critical constants of reduced crudes or oils containing tarry matter. This problem, while

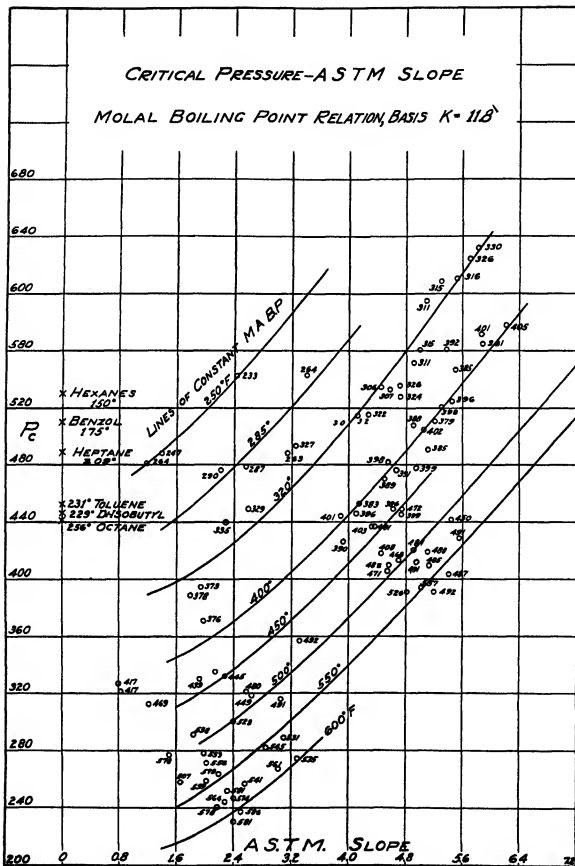

FIG 10

falling partly under (4) above, is more difficult because of the probable rapid coking of the observation chamber. It has been found impossible to run dirty stocks having even relatively low critical temperatures (around 900° F) be-

cause of this last effect. It seems probable that this problem can be solved only to the extent that the reduced crudes can be cleaned and the observed results on the clean oil applied to the original material.

REFERENCES

- 1 BAHKE, W H., and KAY, W B *Ind Eng Chem* **24**, 291 (1932)
- 2 BURGE, R T *Phys Rev* **40**, 207 (1932), particularly pp 224-7
- 3 COPE, J Q., LEWIS, W K., and WEBER, H C *Ind Eng Chem* **23**, 887-92 (1931)
- 4 EATON, G L., and PORTER, C A *Ind Eng Chem* **24**, 819 (1932)
- 5 *International Critical Tables*, 3, 381
- 6 KAY, W B *Ind Eng Chem* **28**, 1014-19 (1936)
- 7 MCKEE, R H., and PARKER, H H *Ind Eng Chem* **20**, 1169 (1928)
- 8 MCKEE, R H and SZAYNA, A *Ind Eng Chem* **22**, 953 (1930)
- 9 PERRY, J H *Chemical Engineer's Handbook*, 1794 (1934)
- 10 ROSS, L C *J I P T* **22**, 665-705 (1936)
- 11 WATSON, K M., and NELSON, E F *Ind Eng Chem* **25**, 880 (1933)
- 12 WEIR, H M and EATON, G L *Ind Eng Chem* **24**, 211 (1932)
- 13 ZEITFUCHS, E H *Ind Eng Chem* **18**, 79-82 (1926)

NOTE

Figures 1 to 18 (inclusive) are reproduced by permission from 'J I P T', **22**, (Oct 1936)

CONVERSION OF BOILING-POINTS OF PETROLEUM FRACTIONS

By E. S. L. BEALE, M.A., F Inst P
Consultant in Engineering Physics, London

It is frequently necessary to calculate what the effect of a change in pressure on the boiling-point of a petroleum fraction will be. For instance, when a distillation analysis is being carried out on a sample the pressure is seldom exactly 760 mm of mercury, which is the standard pressure at which all boiling-points are compared.

For accurate distillations at atmospheric pressure it is necessary to allow for the difference between the absolute pressure at the point in the distillation system where the temperature is measured (usually very close to the atmospheric pressure at the time) and the standard pressure, even when the difference is only about 10 mm.

For this particular purpose the most convenient form for the correction is in the terms of change in boiling-point ($^{\circ}\text{C}$ or $^{\circ}\text{F}$) per mm change of pressure.

As will be seen later, factors of this type can be given which are applicable to all hydrocarbons and petroleum fractions of narrow boiling range, depending on the boiling-point of the material. A typical set of these factors are given in the following table and can be regarded as accurate over a pressure range of 760 mm \pm 50 mm.

Boiling-point at 760 mm, $^{\circ}\text{C}$	Correction factor, $^{\circ}\text{C}$ per mm
-100	0.023
-50	0.029
0	0.035
50	0.040
100	0.046
150	0.051
200	0.056
250	0.061
300	0.065
350	0.069
400	0.073

In the case of high-boiling fractions the distillation has to be carried out at a low pressure in order to prevent thermal decomposition. It is, of course, well known that the boiling-point can be lowered very greatly if the pressure is reduced to, say, 1 mm. Thus a hydrocarbon which would have a boiling-point of about 415°C at 760 mm would boil at 200°C under an absolute pressure of 1 mm. Such a compound could probably not be distilled at atmospheric pressure without serious decomposition, whereas at 1 mm there would probably be little or no decomposition.

For the purposes of identification the boiling-point at any pressure would be adequate, provided the pressure is given, but it is a great convenience, particularly when making a distillation analysis of a petroleum product containing high-boiling compounds, to be able to convert the boiling-points of all fractions, as determined at perhaps a succession of decreasing pressures, to the standard pressure, 760 mm, so that the boiling-point of all fractions can be easily compared.

There is another rather different case in which a convenient means of estimating the effect of pressure on the boiling-point is also constantly required, namely, the estimation of the vapour pressure of the components in a distillation product of petroleum for the purpose of fractionating column calculations. For all components boiling

above, say, 36°C (*n*-pentane) or 70°C (*n*-hexane) it is usual to treat petroleum products as if they consisted of a continuous mixture of hydrocarbons differing infinitesimally in boiling-point for commercial fractionating column calculations. The mixture is then divided into convenient arbitrary fractions of narrow boiling range, such as 10° or 20°C , and the separation between the fractions calculated. It is then required to estimate the vapour pressure of each of these fractions at the temperature existing in the column at each point, or, expressed in the equivalent way, to estimate the pressure at which the boiling-point of each of these fractions would be equal to the temperature in the column at each point.

Yet another occasion when boiling-point conversions are required is when calculating the equilibrium boiling-point or flash temperature of a hydrocarbon mixture, as, for instance, when calculating the temperature at some point in a fractionating column.

When calculating equilibrium temperatures in a fractionating column the method adopted is to calculate the partial pressure of each fraction in the mixture at a temperature which is estimated to be close to the true equilibrium temperature. The sum of the partial pressures of all the fractions gives the vapour pressure of the mixture at the estimated temperature. As this vapour pressure will not be exactly equal to the actual pressure in the column at the point under consideration, it is necessary to adjust the boiling-point of the mixture over a relatively small range of pressure to obtain the equilibrium temperature at the actual pressure in the column.

There is a great deal of experimental data of good accuracy and reliability on the vapour pressure of the lower boiling hydrocarbons, more particularly up to a boiling-point of about 126°C (*n*-octane), which is the limit of the classical work of Young [1, 1909]. The vapour pressures of a great many individual hydrocarbons are available in various convenient graphical forms.

(1) The data is plotted as straightforward vapour pressure—temperature lines for individual hydrocarbons, using special scales for both axes so as to obtain practically straight lines. Well-known examples of this type of plotting are that given by Ashworth [1, 1924] in which $\log P$ is plotted against $1/F(T^{\circ}_{\text{sat}})$, the temperature scale being an empirical function of the absolute temperature which was found to give accurately straight lines, and that given by Cox [6, 1923] in which the vapour pressure of each hydrocarbon is plotted in terms of the vapour pressure of water after the manner of Dühring's rule, thereby obtaining practically straight lines.

Another method for this type of chart used by Wilson and Bahlke [10, 1924] is simply to plot the available data on a scale of $\log P$ against $1/T^{\circ}_{\text{sat}}$, which gives only very slightly curved lines which enable interpolation to be accurately carried out. Two charts of this type are shown in Figs 1 and 2 (taken from Technical Data on Fuel, 1935). These consist chiefly of the normal paraffins, but it will be seen that substances of very different constitution, such as benzene and toluene, do not have appreciably different slopes. The curves for petroleum products on Fig. 2 will be mentioned later.

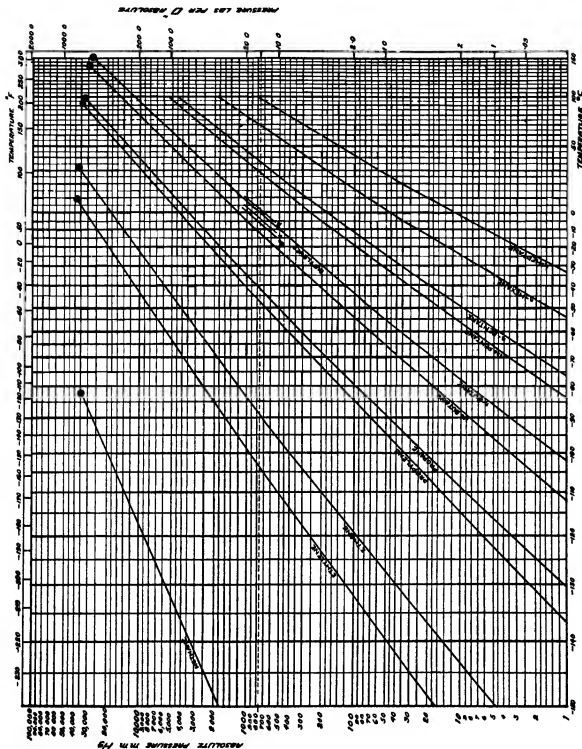

FIG 1
 (Reproduced by permission from 'Technical Data on Fuel', edited by H. M. Sperry)

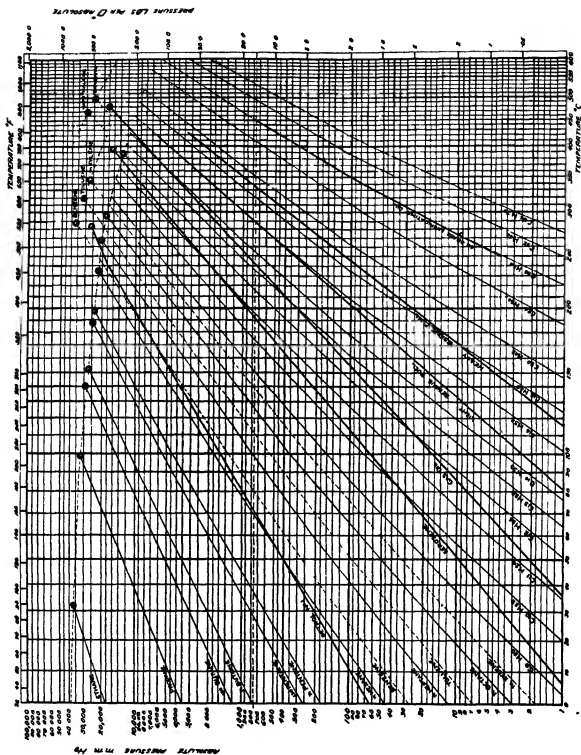

Fig. 2
 (Reproduced by permission from "Technical Data on Fuels", edited by H. M. Speert)

(2) The data is plotted in the form of lines of constant pressure on uniform scales of boiling-point at 760 mm against boiling-point at P mm. The lines of constant pressure are very nearly straight on this type of chart, more particularly at the high-temperature end. This method has been adopted by G. G. Brown [4, 1928], who has published large-scale charts for pure hydrocarbons on these lines (see also Coats and Brown [5, 1928]). The data for the low-boiling hydrocarbons is accurate enough to distinguish

The substances marked *J, K, L, M, N, O* were petroleum fractions of very narrow boiling range, chosen so as to extend the data at the upper end of the chart.

(3) The data is given in the form of an alignment chart with three scales, namely, Boiling-point at 760 mm., Temperature, and Pressure. When given in this form it is assumed that the data for all hydrocarbons may be accurately enough represented as belonging to a single family, since the different components are characterized only by

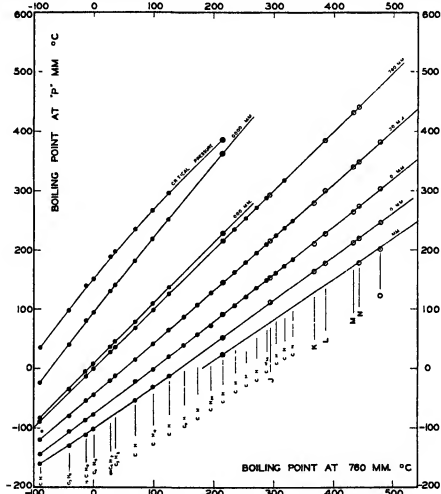

FIG 3
(Reproduced by permission from 'J Inst Petroleum Technologists' 868, Oct 1935)

between the slope of the vapour-pressure lines of hydrocarbons belonging to different chemical series. On this type of chart this effect is represented by the more or less vertical straight lines representing individual hydrocarbons being drawn at a slight angle to the vertical, and in some cases these lines are somewhat curved in order to represent the data more exactly.

The deviation from the vertical of these lines is small even in the case of the lower members of the series. The deviation tends to become smaller with the higher members, and since the data is also more scarce and less accurate in this region, all the high-boiling hydrocarbons may be regarded as forming a single family.

Fig 3 shows a chart on these lines taken from Beale and Docksey [3, 1935] which shows the progressive straightening of the lines of constant pressure at high temperatures.

their boiling-point at 760 mm. As mentioned above, this is a satisfactory approximation in the case of all but some of the lower boiling compounds.

Examples of this type of chart were given by O. G. Wilson [9, 1929], and more recently by Watson and Wirth [8, 1935]. Beale and Docksey [3, 1935] gave experimental evidence at high temperatures and low pressures leading to substantially different conversions at pressure below 10 mm of mercury absolute. As all the possible causes of inaccuracy in this region were carefully examined and allowed for where possible, their chart is probably the most accurate so far available, as it is in agreement with the accepted data at the higher pressures and lower temperatures. This particular chart is reproduced in the article on Distillation in the Refining of Petroleum by W. A. Peters.

This chart has been extended by Beale [2, 1937] so as to

include vapour pressures above atmospheric and a wider range of boiling-points so as to cover the cases mentioned above required in fractionating column calculations. This chart is shown in Fig 4. If the pressure scale of the extended chart is compared with that of the original chart,

the vapour pressure of a hydrocarbon mixture containing some very light fractions. The boiling-point scale has been extrapolated up to 1,000° C so as to enable a vapour pressure to be used for the very high boiling components which are now known to exist in some crude oils. This

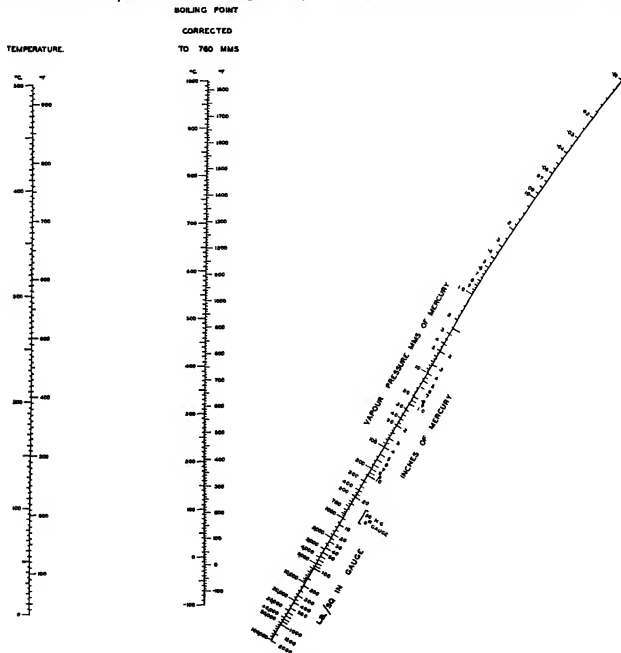

FIG 4

it will be noticed that it is straight from the highest pressure, 100,000 mm, down to 10 mm instead of being slightly curved. It was found that the whole data could most accurately be represented in this way and that the difference in the converted boiling-points given by the new and the old charts at intermediate positions was not more than 1° C, which is within the expected accuracy of such charts.

The pressure scale extends well above the critical pressure of all hydrocarbons, but it represents the extrapolations of the vapour-pressure lines and is useful for estimating

extrapolation is possible owing to the fact that, as mentioned above, the lines of constant pressure on the method of plotting described under (2) above become perfectly straight at high temperatures.

This chart (Fig 4) was used for the correction of the boiling-points to 760 mm of the high-boiling pure hydrocarbons given in the Table of Physical Properties in another article [7].

An extension to the use of such charts has been suggested by Beale [2, 1937] for the correction of the boiling-points

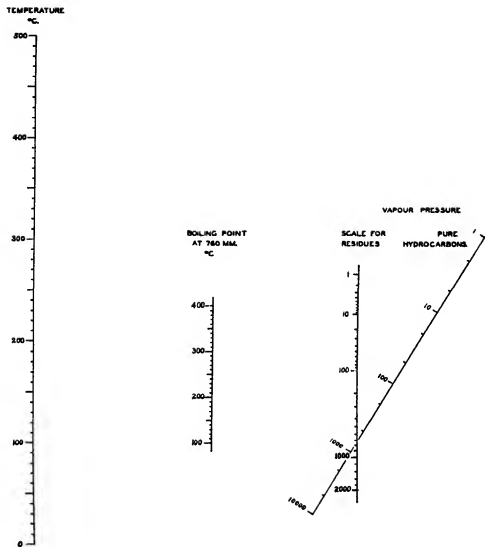
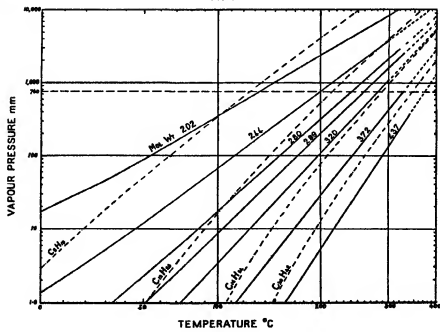

FIG 5



G g

of petroleum mixtures of wide boiling range such as residues from a crude oil

The form taken by this chart in the case of a series of fractionated residues from a mixed-base crude is shown in Fig 5, the corresponding vapour-pressure lines from which it was constructed being shown on Fig 6 This chart, of course, only applies to the particular crude oil to which it refers, but a method is given for calculating the pressure scale in any particular case, and this may be accurate enough for correcting the boiling-point over a small temperature range which is all that is normally required These charts are included primarily to emphasize the difference

between the slope of the vapour-pressure lines for products of wide boiling range and the slope for narrow cuts and pure hydrocarbons with the same boiling-point at 760 mm This difference in slope is also clearly to be seen in the case of the various petroleum products shown on Fig 2 These were normal commercial products having the usual wide boiling range of 100° C and over, with the exception of the 140 grade lubricating oil which has a fairly narrow boiling range and consequently has a slope practically the same as a pure hydrocarbon It is clear, therefore, that the normal chart cannot be used for correcting the boiling-points of wide cuts

REFERENCES

- 1 ASHWORTH, A A *J I P T* 10, 787 (1924)
- 2 BEALE, E S L *J I P T* 22, 311 (1937)
- 3 BEALE, E S L, and DOCKSEY, P *J I P T* 21, 860-70 (Oct 1935)
- 4 BROWN, G G *Proc Nat Gas Assoc* 43 (1928)
- 5 COATS and BROWN *A Vapour-Pressure Chart for Hydrocarbons* Dept of Eng Research, Univ of Michigan, Circular Series no 2 (Dec 1928)
- 6 COX, E R L *Ind Eng Chem* 15, 592 (1923)
- 7 EATON, G L Article on the Properties of Pure Hydrocarbons
- 8 WATSON, K M, and WIRTH, C *Ind Eng Chem, Anal Ed* 7, 72 (1935)
- 9 WILSON, O G *Ind Eng Chem* 20, 1363 (1929)
- 10 WILSON, O G, and BAHLKE, W H *Ind Eng Chem* 16, 115 (1924)
- 11 YOUNG, S *Sc Proc Royal Dublin Soc* 12, 389 (1909)

PHYSICAL PROPERTIES AND MOLECULAR STRUCTURE

METHODS OF DETERMINING VAPOUR PRESSURE, CRITICAL POINT, AND VAPOUR DENSITY

By Professor O. MAASS and J. H. MENNIE
Department of Chemistry, McGill University

The exact measurement of the various physical constants of petroleum products is becoming increasingly of interest and importance. It is the purpose of the present article to describe briefly the experimental technique involved in the measurement of density, both in the gaseous and liquid state, the vapour-pressure of liquids, and the constants related to the critical point where the transition between the liquid and gaseous states takes place.

The properties of liquids and gases will be first of all discussed from the point of view of the molecular kinetic theory. To give an account of the experimental evidence and the process of reasoning which led to the development of this theory would, of course, be far beyond the scope of this work. What follows is intended merely to clarify the subsequent description of experimental methods, and to indicate how data covering a wide range of temperatures and pressures may be calculated from the results of a limited number of experimental measurements.

A distinction must be drawn between one-component systems and systems containing more than one component. The product under examination constitutes a one-component system when its composition, in either gaseous or liquid state or both, can be represented by a single chemical formula. A pure chemical compound, of course, comes in this category. The product is described as a two-component, three-component, multi-component system, &c., where two, three, or a number of separate chemical formulae are necessary to define the composition of whatever forms, gaseous or liquid or both, may be present.

One-component Systems

Gas or Vapour Density.

The density of a substance in the gaseous state is dependent on pressure as well as temperature. The simplest expression of this relationship is the so-called 'ideal gas law'

$$PV = \frac{W}{M}RT$$

In this equation W is the weight of gas occupying a volume V at pressure P and temperature T . R is a constant known as the gas-constant. A single component in the gaseous state may consist of single molecules corresponding in composition to the molecular formula, or of associated molecules formed by the union of two or more single molecules, or of an equilibrium mixture of single and associated molecules. The quantity M in the gas-law equation is the average weight of the molecules actually present expressed in terms of the weight of an oxygen atom taken as 16. If P is expressed in atmospheres, V in litres, W and M in grams, and T in degrees on the absolute scale, the constant R has a numerical value of 0.08209.

The ideal gas law is strictly true only if the pressure of the

gas is infinitesimally small. Expressed in mathematical language, PV approaches the value $\frac{W}{M}RT$ as P approaches 0.

However, it holds approximately at pressures up to 1 atm and provides a means of calculating the density of the gas for any temperature and pressure within this limit, providing that M is known. The value of M may be determined either by the well-known Dumas method [5] or the Victor Meyer method [17]. The Dumas method is suitable for a substance which can be obtained pure in the liquid state. The Victor Meyer method is less accurate, but may be used to advantage when the substance to be examined contains traces of impurities. For low pressures, a more accurate means than the ideal gas law affords for the estimation of the density of a gas at various pressures and temperatures is given by the expression [3, 1932]

$$PV^2 + a - RTV = \frac{RTb(1 + 273.18K)}{1 + KT}$$

where $W = M$. The quantities a , b , and K are specific constants for each individual substance. To establish the values of these constants for a given substance the density must be determined directly at three different temperatures. The technique necessary to give the desired accuracy will be described later.

For gases at higher pressures (over 5 atm.) neither of the foregoing equations adequately expresses the variation of density with pressure and temperature. The equation of van der Waals [21, 1873], $(P + a/V^2)(V - b) = RT$, where $W = M$, is a first approximation. The constants a and b have a specific value for each individual substance. An equation suggested by Keyes [8, 1917],

$$\left(p + \frac{a}{(v+b)^2}\right)(v - \beta e^{-\alpha/v}) = RT,$$

agrees more closely with experimentally determined results. It involves three constants, the numerical values of which must be found for each individual substance by the methods to be described later.

Vapour-pressure.

When a gas is compressed at a temperature below the critical point, liquefaction occurs. A liquid is supposed to consist of molecules free to move about within the liquid in a manner quite analogous to the movement of gaseous molecules. They are, however, much closer together, and their mutual attraction plays a much more important part. A molecule approaching the boundary of the liquid is held back by the attraction of the other molecules, and only if its velocity is sufficiently great will it be able to pass through the liquid surface and break away from the liquid into the gaseous phase above. The condition for the existence of a liquid, therefore, is that the average kinetic energy of the molecules in the liquid must be less than the work which

a molecule must do against the forces of intermolecular attraction as it approaches and passes through the surface of the liquid. The average kinetic energy of the molecules is proportional to the temperature, but at any given temperature a definite fraction of the molecules possesses energy in excess of the average value. That is, at any given temperature a definite fraction of the molecules is moving with a velocity sufficient to permit their escape from the liquid surface. At the same time gaseous molecules moving downwards strike the liquid surface, and a certain number of them will fail to rebound beyond the range of the attraction of the liquid molecules, and will be caught and held by the liquid. Hence a dynamic equilibrium is established between the molecules in the liquid and the molecules in the gas above. This gives rise to the phenomenon of vapour-pressure which has a definite value at a given temperature for each liquid.

The relationship between vapour-pressure and temperature may be expressed by the equation

$$\log P = -\frac{ML}{RT} + I,$$

where M , R , and T have the same significance as before, I is a constant, and L is the latent heat of vaporization. This holds fairly accurately at low temperatures where the latent heat does not vary greatly with changes in temperature. A more exact equation, due to Nerst [7, 1906], must be used at higher temperatures

$$\log P = -\frac{A}{RT} + 1.75 \log T - \frac{bT}{R} + C$$

To establish the values of the constants A , b , and c , three experimental determinations of the vapour-pressure at different temperatures must be made. Another method representing such data in terms of fugacity has been developed by W. K. Lewis [11, 1933].

Liquid Density.

There is no accurate mathematical expression of the variation of the density of a liquid with temperature, although approximate values may be obtained from the equation of van der Waals. However, if the density of a liquid has been measured at one temperature and the critical temperature of the liquid is known, it is possible to calculate the density at other temperatures. The percentage increase in volume of all liquid hydrocarbons is approximately the same between the same corresponding temperatures. The 'corresponding temperature' or reduced temperature is defined as the ratio of the temperature at which the measurement is made, to the critical temperature (both measured on the absolute scale). If the density of a liquid has been measured at one temperature and it is desired to find it at some other temperature, the two temperatures in question are first converted to corresponding temperatures by dividing each by the critical temperature of the liquid. There are many liquids whose densities have been accurately measured by direct experiment over a wide range of temperature. Such data are available in tables of physical constants. The density values for one of these are obtained for the same two corresponding temperatures. Then the percentage change in density will be the same for the liquid under investigation and the reference liquid [14, 1921].

The Critical Point.

If a closed tube, which has been filled about three-eighths full of liquid before being sealed, is heated gradually, a

temperature is eventually reached at which the visible line of demarcation between liquid and gas, known as the meniscus, suddenly disappears. This is the critical temperature. Above this temperature no pressure, however high, will cause a meniscus to appear, i.e. increasing the pressure can no longer produce visible condensation of gas to liquid.

The critical temperature may be estimated in many cases from measurements of surface tension by means of the Ramsay and Shields formula [15, 1921],

$$\sigma \left(\frac{M}{d} \right)^{2/3} = 2.12(T_c - 6 - T),$$

in which T_c is the critical temperature, M is the molecular weight, and σ and d are respectively the surface tension and density of the substance at the temperature T .

As the temperature rises, the density of the liquid decreases and that of the gas in equilibrium with the liquid increases. It was formerly supposed that at the critical temperature they became equal. Actually this is not the case. Even above the critical temperature, after the disappearance of the meniscus, the medium which fills the tube is not homogeneous. The portion below the point where the meniscus was last seen remains more dense than the portion above. Stirring does not bring about uniformity, but the difference in density diminishes if the temperature is further raised. Then, if the temperature is lowered gradually, the original difference in density has not been found to be restored until the temperature falls below the critical value, when separation into liquid and vapour takes place again and the meniscus reappears.

The critical temperature is generally regarded as the temperature at which the average kinetic energy of the molecules becomes sufficient to overcome the effect of intermolecular attraction. The phenomenon just described may be called the persistence of the liquid state above the critical temperature. It suggests that the liquid state may be distinguished from the gaseous by a structure due to regional orientation of the molecules [6, 1935, 20, 1933, 23, 1933].

The magnitude of the density difference existing above the critical temperature depends on the nature of the liquid and on the amount of material in the closed tube. The greater the polarity of the liquid and the greater the amount present, the greater is the density difference and the longer does it persist as the temperature is raised above the critical temperature. A method for measuring such densities is described later.

Systems of More than One Component

In one-component systems a few measurements suffice for the calculation of densities and vapour-pressures over a large temperature range. In systems of two or more components the complexity of the measurements is greatly increased. No relationships of a sufficiently general character are known, and densities and vapour-pressures have to be determined for each temperature at which the data are desired.

An exception may be made in the case of the density of gas mixtures at low pressures. According to Dalton's Law of Partial Pressures [4, 1801], which is approximately true, the pressure of a gas is independent of the presence of other gases. Hence the density of a gas mixture may be calculated from its composition, if the value of M for each component is known, by making use of the ideal gas law. But Dalton's law does not hold exactly even at low pres-

sure, and even in the case of gases for which the constants a and b of van der Waals' equation have exceptionally low values. For instance, when equal volumes of helium and carbon dioxide, each at 760 mm pressure, are brought in contact, there should be, according to Dalton's law, no change in the pressure. Actually an increase of 3.5 mm is observed [13, 1924]. At higher pressures the deviation from Dalton's law is still greater. When argon and ethylene are brought together at 100 atm, there is a decrease in pressure of 8 atm [16, 1923]. Even if the values of the van der Waals constants are known for each of the component gases, it is impossible to calculate values for a and b for the mixture.

In systems of two or more components the critical phenomena are much more complex. For instance, after the temperature has been raised to a point where the meniscus has disappeared, increasing the pressure may cause a meniscus to reappear. This will be discussed in connexion with the description of the experimental determination of the critical point.

The Measurement of Gas Densities

Accurate Measurements at Low Pressures.

The measurement of the density of a gas involves the determination of the volume, temperature, pressure, and weight of a sample of the gas. The gas is introduced into a containing vessel of accurately measured volume which is immersed in a thermostat at a definite temperature, and the pressure is read on a manometer. If the container is simply closed, removed from the thermostat, and weighed, its own weight is necessarily so much greater than that of the gas which it contains that the latter cannot be obtained with an accuracy comparable to the accuracy with which the pressure, volume, and temperature measurements may be made.

This difficulty is overcome in the following method by which, in fact, the weight may be made the most accurately determinable factor [2, 1930]. The method is applicable to all gases which can be condensed readily at the temperature of liquid air, and when the apparatus has once been set up and calibrated the procedure is quite simple and rapid.

The apparatus is represented diagrammatically in Fig. 1, which is not drawn to scale. The volume of the flask A up to the stopcock is accurately determined, which may be done by weighing it filled with distilled water. The whole apparatus is evacuated through E . The gas is then admitted through D , filling the flask and connecting tubing to the pressure at which the density is to be determined. The stopcock G is closed and, the flask being kept at a constant temperature by means of the surrounding thermostat, the pressure is observed on the manometer, which may be read by means of a cathetometer. The stopcock of flask A is closed and the flask then contains a sample of gas of which the volume, pressure, and temperature are known. The connecting tube is then all evacuated through stopcock G and it is again closed. The stopcock on the flask A is then opened, and the sample of gas which it contains is condensed in one of the bulbs B by immersing the bulb in liquid air. The capillary neck of the bulb is sealed off, and the bulb allowed to warm up to room temperature and weighed. It is again cooled and opened by breaking the capillary. The gas is permitted to escape and the glass is weighed. The difference between the two weighings gives the weight of the gas which was contained in A . The

residual pressure at liquid-air temperature is negligibly small, so that no dead-space correction is necessary.

The volume of the flask A can be chosen to suit the degree of accuracy required. Volumes from 1 to 50 litres have been used. The bulb B must have walls thick enough to withstand the pressure of the condensed gas at room temperature, but its volume is only 1/100 to 1/1,000 of that of the flask A . An accuracy of 1 part in 5,000 was easily obtained in the measurement of the density of carbon dioxide by this method. With gases more easily condensable or of higher molecular weight still greater accuracy is possible.

The density, of course, is given by $W/1,000V$. If measurements are made at three different temperatures, the relationship already mentioned may be used to calculate the density for other conditions of temperature and pressure. By using pressure taps [12, 1923], measurements can be made up to 5 atm. For gases which are liquid at ordinary room temperature, condensation in the connecting tubing may be avoided by surrounding it with electrically heated nichrome wire.

Manometers. For the apparatus described above a mercury manometer is most suitable. For measurements of the highest accuracy it should be enclosed in a thermostat and read by means of a cathetometer. It should be constructed as shown in Fig. 1, so that the two mercury-levels can be read without turning the cathetometer through an angle. For pressures between 1 and 5 atm a calibrated scale attached to the manometer is sufficiently accurate. Adjustment of the mercury-level may be made by raising and lowering a mercury reservoir connected to the manometer by rubber tubing, but it is best effected by varying the pressure on the mercury in the reservoir which is connected as shown in Fig. 1. Tube F may be connected to a vacuum or pressure line, or opened to the air through taps not shown in the diagram.

For the measurement of pressures above 5 atm and up to 300 atm the Bourdon gauge has been generally used. This consists of a metal tube closed at one end and coiled in the form of a helix. It extends with increase in pressure, its motion being magnified and transmitted to a pointer by a system of levers. These gauges require constant standardization, since not only the zero value, but the extension with pressure may vary while the gauge is in use.

The most accurate instrument for the measurement of high pressures is the dead-weight gauge [10, 1931]. An accuracy of 1 in 5,000 is readily attainable at pressures up to 100 atm, and the method is applicable to pressures over 1,000 atm. The pressure is transmitted by an oil column to a vertical steel piston fitting snugly in a steel cylinder, and is counterbalanced by weights applied to the top of the piston. Frictional effects are overcome by a device which either rotates or oscillates the piston. The oil is separated from the gas whose pressure is being measured by a column of mercury in a steel U-tube, which serves to indicate when equilibrium is obtained. Movement of the mercury is detected by electrical contacts.

The pressure is equal to the weight applied to the piston in grams (W) divided by the effective area (A) of the piston, which may be taken as the mean of the cross-sections of piston and cylinder. If distortion of the gauge due to pressure is negligible, the pressure expressed in atmospheres is

$$P = CW \quad \text{The quantity } C = \frac{1}{A \times 76\rho} \times \frac{g}{981} \text{ is a constant}$$

for the gauge employed, where ρ is the density of mercury in grams/c.c. and g is the acceleration due to gravity in

cm./sec.² in the particular locality. There is a steady escape of oil which forces its way between piston and cylinder, serving incidentally as a lubricant. The forces produced by the escaping oil are a constant percentage of the weight of the piston. The gauge constant is best obtained by calibrating the instrument at a pressure of several atmospheres measured by a column of mercury, or against the vapour-pressure of liquid carbon dioxide. For a gauge of normal specifications the piston does not vary in diameter by more

cooled with solid carbon dioxide, for lower temperatures. The temperature is measured by means of a carefully calibrated platinum resistance thermometer.

Buoyancy Method. The weight of a body suspended in a fluid is less than its weight *in vacuo* by an amount equal to the weight of fluid which it displaces. Thus, the principle of Archimedes, is frequently employed in determining the density of liquids, as, for instance, in the use of the familiar hydrometer. The density of gases is ordinarily so much

less than that of liquids that the buoyancy effect is difficult to measure with much accuracy. But if the density of the gas is relatively great, as, for instance, at high pressures, and a sufficiently sensitive means is available of measuring the effect of buoyancy on a float of known volume, the method is applicable to gases also. The McBain-Bakr quartz-spiral balance provides an instrument of the necessary sensitivity and compact enough to be enclosed in a container filled with gas under pressure. Measurement of the extension of a quartz spiral spring, from which a suitable float is suspended, is the most accurate means available in the pressure range 5 to 100 atm. for measuring the density of the medium, whether gas or liquid, displaced by the float. The method is applicable to systems of one or more than one component, and is the only one so far developed which permits measurement of the

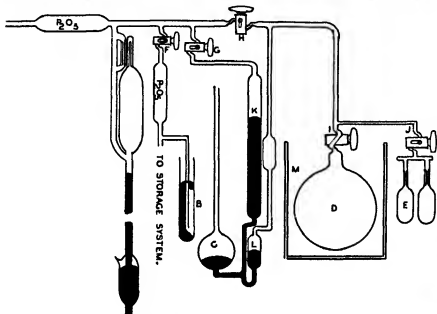

FIG 1 High-precision mercury manometer

than 0.0001 cm. throughout its length. The gauge constant is found to increase slowly with time owing to the ageing of the hardened steel of the piston.

Measurements at High Pressures.

Various methods of determining P, V, T relationships at high pressures [1, 1932, 9, 1921-2] have been developed. That of Keyes [9] is typical of the procedure which can be used to measure accurately the density of a condensable gas. A measured amount of gas is maintained at constant volume in a steel container known as a piezometer, and the pressure at various temperatures measured by means of the dead-weight gauge.

The weight of gas introduced into the piezometer is found by measuring its volume at a lower pressure where its density has previously been accurately determined by some method such as that already described. A gas burette of known volume and kept at constant temperature is exhausted and the gas allowed to enter, its pressure being read on a manometer. The gas is then displaced from the burette with mercury and condensed in the piezometer by immersing the latter in liquid air. The small opening of the piezometer is closed with a gold washer screwed tightly in place, and the piezometer is then attached to the mercury column of the dead-weight gauge. The gold washer is dissolved by the mercury establishing contact between the gauge and the gas in the piezometer.

The temperature is controlled by surrounding the piezometer with a suitable bath contained in a silvered Dewar flask. A high-boiling oil, heated electrically, is used for temperatures up to 200° C. Ice is used at 0° C., and ether,

differences in density which exist in the medium above the critical temperature.

The essential features of the apparatus [23, 1933] are illustrated in Fig 2. Two bombs, each of capacity about $\frac{1}{2}$ litre, are machined from shafting steel and provided with covers secured by steel bolts. Grooved lead gaskets, coated with a graphite composition, serve to prevent leaks. The second bomb contains a pyrex glass bell, attached to which is a heavy-walled capillary tube passing through a steel pipe screwed into the cover of the bomb. A rubber gasket held in place by a steel plate bolted to a flange on the pipe forms a mercury-tight seal. The glass bell fits inside a larger steel pipe screwed into the underside of the cover and rests against a thick rubber disk inserted between the top of the bell and the cover to prevent any lateral or vertical movement which might break the glass capillary. The first bomb is two-thirds filled with mercury, and the remaining space is filled with oil which is connected through a valve to a Cailletet pump. The second bomb contains mercury alone so that the gas comes in contact only with glass and mercury.

The glass bomb is of pyrex tubing of 1.5 cm. internal diameter and 4 mm. wall thickness, and is connected by heavy-walled capillary tubing to the glass bell in the second steel bomb. A suitable manometer may be inserted where the break in the line appears in the diagram. The spiral balance is 4 to 5 cm. long and about 0.5 cm. in diameter. It is wound by a special machine [19, 1932] from a quartz fibre less than 0.1 mm. diameter. It is calibrated by suspending it from a rigid support, attaching various weights to the lower end, and observing with a cathetometer the

total length corresponding to each weight. The sensitivity is about the same as that of a good analytical balance. Suspended from the spiral is a pyrex glass float which has been accurately weighed and the volume of which has been found from the weight of water displaced when it is introduced into a specific gravity bottle.

To introduce the gas under examination, the upper end of the bomb tube is connected to a pump and to the gas reservoir. Mercury from the steel bomb can be forced over into the U-tube shown in the diagram and there frozen by

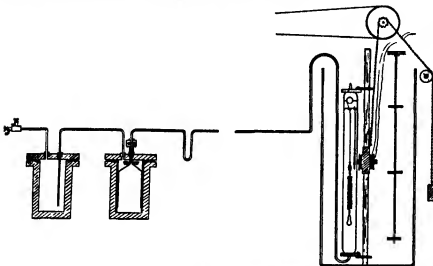

FIG 2 McBain-Bakr quartz-spiral balance

immersing the U-tube in solid carbon dioxide and acetone contained in a Dewar flask, thereby forming an effective seal. The bomb-tube is evacuated and the gas then condensed in it by surrounding it with solid carbon dioxide or liquid air. The upper end is sealed off, the glass jar which serves as a thermostat is filled with a suitable liquid, and the temperature brought to the desired value. The volume occupied by the medium in the bomb, and hence, if no liquid is present, its pressure also, may be varied by forcing mercury into the bomb by means of the Calletet pump, and may be held at a fixed value by freezing the mercury in the U-tube.

The apparatus as illustrated in Fig. 2 is designed to permit measurements to be made of both gas and liquid densities below the critical temperature and to explore the discontinuity existing above the critical temperature. The quartz spiral is suspended by a silk thread which passes over a small glass pulley to a counterpoise consisting of an iron nail sealed in a glass tube. The whole assembly is supported by a short glass collar which just fits inside the bomb-tube and rests on two indentations in the wall of the latter. The iron counterpoise can be moved up and down by an electromagnet which slides on a vertical rod alongside the bomb, thus altering the position of the quartz spiral in the tube. If sufficient of the medium has been introduced so that below the critical temperature a layer of liquid occupies the lower part of the bomb, the float may be immersed either in the liquid or the vapour above it, and the density of both may be found under the same conditions of temperature and pressure.

Owing to the possibility of the glass bomb bursting at high pressure, the cathetometer, temperature-measuring instruments, controls, &c., must all be placed at some distance from the bath and suitable screens introduced for the protection of the operator.

This apparatus permits measurement of density with an accuracy of about 1 in 1,000 at pressures of 5 to 100 atm and temperatures of 0 to 200° C. It is only necessary to know the weight (w) and volume (v) of the float and the sensitivity in grams per mm extension (S) and the normal length (N) of the quartz spiral. Then if x is the length of the spiral when the float is immersed in a medium of density, d ,

$$d = \frac{w - (x - N)S}{v}$$

Since $d = W/V$, the simultaneous observation of d , P , and T provides all the data for the application of one of the general relationships discussed in the first section.

Vapour-pressure Measurements

It must be remembered that a liquid possesses a constant vapour-pressure at a given temperature because there exists a dynamic equilibrium between the molecules in the liquid and those in the vapour phase in contact with it. A change in temperature alters this equilibrium, and time is required for it to be re-established. As the vapour-pressure increases, some of the liquid evaporates and heat is absorbed. As the vapour-pressure decreases, some of the vapour condenses to liquid and heat is evolved. It is at the surface

that this latent heat of evaporation is produced or absorbed, so that when the vapour-pressure changes, time is necessary for the re-establishment of temperature equilibrium in the system. Hence, where accurate results are desired, it is essential that the liquid be stirred, and the stirring arrangement should be such that the surface of the liquid is intermittently broken. This is further important in a system of more than one component, because the composition of the vapour will differ from that of the liquid. The rate of molecular diffusion is very slow in a liquid compared to that in a gas, and stirring is necessary to maintain the composition of the surface layer the same as in the bulk of the liquid. Intermittent stirring is readily accomplished with a glass stirrer having an iron core sealed into it, which can be moved up and down by making and breaking the current in an electromagnet placed outside the sealed apparatus.

Since the vapour-pressure depends on the temperature prevailing at the liquid-vapour boundary, it is only the part of the apparatus where this boundary exists which must be kept at a fixed temperature during the measurement. That portion of the vapour which is in contact with the manometer may be at any temperature, provided it is above the temperature of the liquid so that no condensation will occur.

The simplest form of apparatus thus consists of a bulb containing liquid and vapour maintained in a suitable thermostat, with a tube leading to a manometer. If the liquid is at a temperature to which the manometer cannot readily be heated, the tube leading from the bulb may be bent into a U which is filled with mercury, and is enclosed in the same thermostat with the bulb. Between the manometer and the U-tube, vacuum and pressure lines are connected through suitable taps which are manipulated until

the mercury is at the same level in both arms of the U-tube. The pressure indicated by the manometer is then just equal to the vapour-pressure of the liquid. This arrangement can also be used when only small amounts of liquid are available. The vapour-pressure of as little as 0.5 c.c. of liquid can be accurately measured in this way.

The choice of a manometer depends on the accuracy desired and the pressure range to be covered. For pressures above about 3 cm. of mercury one or other of the manometers already described will be suitable. Accurate measurement of very low pressures requires some special arrangement such as the following [18, 1913]

the vapour-pressure of water and of ice which is accurately known down to a pressure of 0.01 cm.

The Critical Phenomena

One-component Systems.

The determination of the critical temperature is simply a matter of gradually raising the temperature of a sealed tube containing the liquid and its own vapour until the meniscus is seen to disappear and noting the temperature at which this occurs. As the temperature of the liquid increases, the pressure in the tube also increases. At each

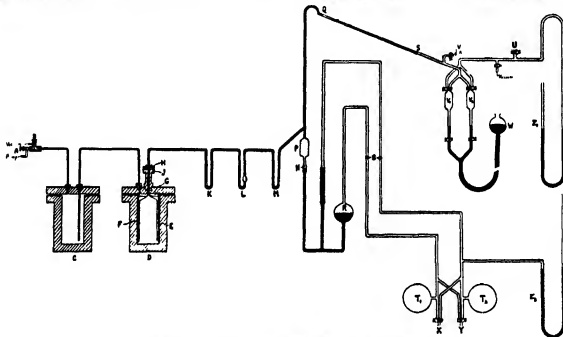

FIG 3 Apparatus for determination of critical data on two-component systems

Two glass tubes about 7 cm. in diameter are connected by a glass tube containing a stopcock. One side is connected through a two-way stopcock to a pump and to the system containing the gas or vapour whose pressure is to be measured. Into the upper end of each arm of the U is sealed a metal block having a finely threaded hole through its centre. A stem with a sharply pointed end can be screwed into each hole until the point touches the mercury. The upper end of each stem carries a disk with graduations around the edge which move past a fixed pointer when the stem is turned. Thus the change in height of the point in contact with the mercury corresponding to a very small fraction of a turn of the threaded stem can be accurately determined.

In operation, the stopcock between the two arms of the U is opened and the space above the mercury thoroughly evacuated. The threaded stem in each arm is carefully adjusted until the point just touches the mercury surface. This condition may be observed visually or may be detected by the closing of an electrical circuit through the pointed stem and the mercury. The stopcock is then closed and the one arm brought in contact with the gas whose pressure is to be measured. The mercury is depressed in this arm and is raised in the other arm. The points are again adjusted to touch the mercury surface by turning the stems. The pressure may thus be measured within 0.0001 cm. Calibration of the instrument is best effected by means of

temperature the pressure has a definite value which is that of the vapour-pressure of the liquid at that temperature. The value which the vapour-pressure reaches at the critical temperature is called the critical pressure. This can be observed with the apparatus described for the measurement of densities by the buoyancy method or that described below for dealing with two-component systems.

Systems of More than One Component.

In a one-component system equilibrium between liquid and vapour can exist only at a single pressure for each temperature. If the pressure is increased slightly as the temperature is kept constant, condensation occurs until the vapour is completely converted to liquid. On the other hand, if the pressure is kept constant and the temperature is slightly raised, evaporation proceeds until all the liquid is gone. Only the slightest variation from the equilibrium conditions is necessary to bring about complete vaporization or complete liquefaction. When more than one component is present the phenomena observed are more complex. If the pressure on the liquid is kept constant and the temperature raised, evaporation proceeds, and at some definite temperature the liquid will just disappear. The pressure observed may be taken as the vapour-pressure of the liquid mixture at that temperature. If now the temperature is kept constant and the pressure increased, condensation will commence, but the amount of vapour condensed

will depend on the pressure, and the pressure required for complete liquefaction of the vapour will be considerably, instead of only slightly, higher than that prevailing at the point of complete vaporization.

An apparatus designed for making such measurements on two-component systems is illustrated in Fig 3 [22, 1932]. The two steel bombs, *C* and *D*, are the same as already described in connexion with Fig 2. The tube *L* is immersed in a bath, the temperature of which can be accurately controlled and measured. The remainder of the apparatus serves for the introduction into *L* of measured amounts of two pure components.

Mercury from the bomb *D* is first forced over until it fills the whole capillary *KLM* and drops into *P*. It is then frozen in the U-bend *M*. The remainder of the apparatus is evacuated and the gases are introduced, one at a time, into the calibrated volumes, V_1 and V_2 . The pressure of each is read on the manometer Z_1 and Z_2 , the temperature being known, the amount of each gas may be calculated. The two gases are then forced out of V_1 and V_2 into the bulb *P* by raising the levelling bulb *W*. The mercury in *M* is allowed to liquefy and the gas mixture is forced over into the glass bell in bomb *D* by applying pressure to the mercury in the reservoir *R* and releasing the pressure in the bomb through valve *B*. The mercury follows the gas mixture from *P* into the U-bend *M* and is frozen there. The bomb *D* is contained in a bath heated above the temperature at which the measurements are to be made, and the connecting tubing is wrapped with electrically heated nichrome wire, so that when pressure is applied by means of the Cailletet pump, condensation to the liquid state occurs only in the tube *L*. The temperature and pressure in *L* may be varied as desired, the pressure being read on a suitable manometer or gauge connected to the oil-line between the bomb *C* and the Cailletet pump. Of course, a single component alone may be introduced in the same way and critical temperature observations may be made, if desired without reference to pressure, with the whole sample of material sealed into *L* by forcing the mercury from *D* over beyond the U-bend *K* and freezing it in *K*.

By way of illustration, the results of a series of measurements with this apparatus on a typical two-component system, carbon dioxide and methyl ether, are shown in Fig 4. Each curve is for a mixture of the two components in different proportions. The lower part of the curve shows the temperatures at which the liquid just disappears when the pressure is held constant at various values. This may be regarded as the vapour-pressure curve of the liquid. The upper part of each curve shows the pressure required for complete condensation of the vapour at various temperatures. The condensation curve and the vapour-pressure curve come together in the critical region and form one continuous curve as indicated in Fig 4. If a tangent to the curve is drawn parallel to the pressure axis, the point at which it touches the curve is called the 'critical contact

point'. The temperature at this point is the highest at which liquid can exist. Above this temperature no pressure, however great, will bring about condensation. It corresponds in this respect to the critical temperature of a one-component system. If a tangent is drawn parallel to the

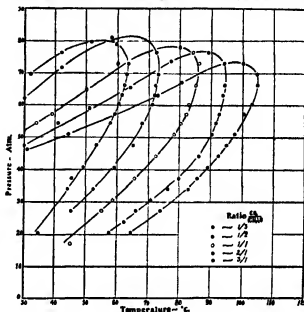

FIG 4 P-T curves for the system carbon dioxide-methyl ether

temperature axis, the point at which it touches the curve is known as the 'plait-point'. The pressure at the plait-point is the highest at which vapour can exist in equilibrium with liquid, or, in other words, it is the maximum limiting value of the vapour-pressure of the liquid. It thus corresponds to the critical pressure of a one-component system.

Evidently a mixture does not possess a definite critical point. Instead there is a critical region which lies between the plait-point temperature and the critical contact temperature and the pressure is gradually increased. When the pressure reaches a value indicated by the lower curve, condensation sets in and liquid appears. As the pressure is increased the proportion of liquid to vapour increases until the pressure corresponding to the critical contact point is reached. Further increase in pressure now causes the proportion of liquid to vapour to decrease again until, when the pressure is that indicated by the upper portion of the curve, the liquid disappears, and at still higher pressures only the gas phase remains. There is thus observed the very curious phenomenon of evaporation of liquid being produced by increasing the pressure. The phenomenon has been called 'retrograde condensation'.

REFERENCES

- 1 BAHLKE, W H, and KAY, W B *Ind Eng Chem* **24**, 291 (1932)
- 2 COOPER, D L B, and MAAS, O *Canad J Res* **2**, 388 (1930)
- 3 ——— *Canad J Res* **6**, 596 (1932)
- 4 DALTON *Nicholson's Journal*, **5**, 241 (1801)
- 5 DUMBS method any elementary text-book on physical chemical measurements
- 6 EDWARDS, J, and MAAS, O *Canad J Res* **12**, 357-71 (1935)
- 7 *Gött Nach* (1906)
- 8 KEYES, F G *Proc Nat Acad Science*, **3**, 323 (1917)
- 9 ——— *J Math and Physics (Mass Inst of Tech)*, **1**, 191-210 (1921-2)
- 10 ——— *Ind Eng Chem* **23**, 1375-9 (1931)
- 11 LEWIS, W K, and LUKE *Ind Eng Chem* **25**, 725 (1933)
- 12 MAAS, O, and MORRISON, D M *J A C S* **45**, 1677 (1923)
- 13 MAAS, O, and MORRISON, D M *Trans Roy Soc Canada*, section III **49** (1924)
- 14 (Examples will be found in) MAAS and WRIGHT *J A C S* **43**, 1098 (1921)
- 15 MAAS, O, and WRIGHT, C H *J A C S* **43**, 1098 (1921)
- 16 MASON and DOLLEY *Proc Roy Soc, A*, **103**, 524 (1923)
- 17 Victor Meyer method any elementary text-book on physical chemical measurements
- 18 MÜNDEL, C F *Z Phys Chem* **85**, 435-65 (1913)
- 19 TAPP, J S *Canad J Res* **6**, 584 (1932)
- 20 TAPP, J S, STRACH, E W R, and MAAS, O *Canad J Res* **9**, 240 (1933)
- 21 VAN DER WAALS *Dissert Leiden*, 1873
- 22 WINKLER, C A, and MAAS, O *Canad J Res* **6**, 458-70 (1932)
- 23 ——— *Canad J Res* **9**, 613-29 (1933)

DETERMINATION OF THE MOLECULAR WEIGHTS OF PETROLEUM FRACTIONS

By C. E. HEADINGTON

The Atlantic Refining Company

THE aim of this discussion is to summarize information on the use of some of the more readily applicable methods of molecular weight determination to petroleum fractions. Until recently these molecular weights have commanded no more than passing interest. The advent of scientific methods in petroleum refining, however, has transformed them into data essential to both the petroleum chemist and chemical engineer. This information is obviously required in any study of the composition of petroleum, and the fact that many physico-chemical laws are derived in terms of molar concentrations makes the molecular weight the connecting link between empirical and theoretical methods in many cases. The application of Raoult's Law in the case of distillation equipment is a notable example.

During recent years the rapid growth of chemical and engineering research on petroleum and petroleum refining has resulted in a large number of publications covering molecular weight determinations obtained by a variety of methods. Because of the complex composition of petroleum the value obtained in practically every case is an average molecular weight. Ordinary methods for these determinations frequently give erratic results because of differences in the behaviour of the components of the solute in the solvent, the presence of unknown amounts of the solvent in the solute, molecular association in solution, and the presence of molecular aggregates of colloidal nature in the heavier residua.

No attempt will be made to discuss the basic laws underlying molecular weight determination, as these are adequately set forth in any text-book of physical chemistry and, with one exception, need no elaboration here. This exception consists of the concept of what is referred to here as 'molecular association'. This is the phenomenon which is often observed when using any of the molecular weight methods dependent on the laws of ideal solutions. 'Molecular association' is a convenient but not wholly satisfactory hypothesis to explain the progressive positive or negative variations in the experimental values which are often observed with changes in concentration. In fact, what is here loosely called 'molecular association' may actually be the resultant of two or more opposing effects which are now obscure. For convenience, however, the term 'molecular association' will be freely used in the discussion of these deviations.

The literature on the subject of petroleum molecular weight determinations is characterized by a lack of agreement among the many contributors on the choice of methods [8, 1934] and is very much in need of a direct comparison of the various methods, including their modifications in regard to solvents and apparatus. Such a comparison, if made on a large number of widely differing pure compounds, known mixtures of such compounds, and petroleum fractions representing the average and extremes in composition, would play a very important part in the correlation of existing information on this subject.

The three methods which will be described here are (a) the cryoscopic method, (b) the ebullioscopic method, and

(c) the vapour-density method. Of these the cryoscopic method has, until recently, been favoured by most investigators. Recent developments in the field of ebullioscopy, however, have improved the boiling-point method to a point where it threatens to supersede the freezing-point method in dependability and precision. Vapour-density methods have been improved, but have not as yet been widely used except on gaseous mixtures.

It should be emphasized here that at present no one method can be recommended for use with all fractions of petroleum. An acquaintance with their relative advantages and disadvantages, however, will enable the investigator to select the method which is most appropriate for the material to be examined.

Cryoscopic Method

The fact that the cryoscopic or freezing-point method has been more widely used than any of the other existing methods is due largely to its simplicity and ease of manipulation. This method may be used for the lighter fractions where it is impossible to apply the boiling-point method due to vaporization of the solute. In this range it is fairly satisfactory, giving rapid and reasonably accurate results, but its extension to higher molecular weight fractions is subject to the limiting factors of (a) molecular association, (b) the formation of mixed crystals, (c) solubility of solute in solvent at the freezing-point, and (d) deviations from the freezing-point law. Of these errors molecular association is largely overcome in the lighter fractions by the proper interpretation of results. This is described in a subsequent section where it is pointed out, however, that this treatment of results becomes increasingly difficult for the higher fractions. Mair [17, 1935] has discussed the other errors and pointed out that in order to avoid the formation of mixed crystals it is necessary to pick a solvent dissimilar in chemical structure from the solute. This in turn may lead to errors due to insolubility or deviation from the freezing-point law.

For these reasons, substantiated by the experience of a large number of investigators, it is recommended that the cryoscopic method be used on the lighter fractions, but limited to liquid fractions whose molecular weights are 400 or less. It has been used for values much higher than this, and in some cases with apparent success, but indiscriminate use of this method on high molecular weight fractions may lead to results which are open to criticism. It is not recommended for use on fractions containing appreciable quantities of paraffin wax because of the low solubility of most waxes in the solvents available. In cases where the solute in question has appreciable vapour pressure at the freezing-point of the solution, a solvent of lower freezing-point may be employed or the vapour-density method may be used.

Cryoscopic Solvents.

Among the many solvents which have been chosen for use in cryoscopic molecular weight work on petroleum

fractions the most popular are benzene, nitrobenzene, cyclohexane, dioxane, ethylene bromide, and stearic acid.

The ideal solvent would be (a) highly miscible with all components of petroleum, (b) easily purified, (c) free from the tendency towards molecular association, (d) able to dissociate molecular aggregates of the solute, (e) a freezing-point in a convenient working range, low enough to keep vaporization of the solute at a minimum. Unfortunately, no single solvent has all of these characteristics, and the investigator is forced to select the one which is best fitted to his particular needs.

The solvent chosen should be used in a highly purified form, and regardless of the information available on the cryoscopic constant it is urgently recommended that each investigator check experimentally the constant for the solvent used with at least two pure compounds. Naphthalene and triphenyl methane are well suited for this purpose, and *iso*-octane is recommended as an additional check on a paraffin-type compound. Such a procedure provides a check on the purity of the solvent and will also disclose errors in either the apparatus or technique.

The physical properties of the solvents described are given in Table I.

TABLE I
Physical Properties of Cryoscopic Solvents

Solvent	Freezing-point, C°	K _f Freezing-point lowering for 1 g mol of solute in 1 g of solvent °C	Reference
Benzene	5.5	4,900-5,230	[13]
Nitrobenzene	5.7	6,890-7,100	[13]
Cyclohexane	6.5	20,000-20,300	[13]
Dioxane (1,4-dioxane dioxide)	11.78	4,630	[14]
Ethylene bromide	10.0	1,180-1,250	[13]
Stearic acid	69.3	4,400-4,500	[13]

Benzene. Of the solvents which have been used in cryoscopic work on hydrocarbon oils, benzene has undoubtedly been the most popular. Its use is accompanied by some association, but in this respect it compares favourably with any solvent that has been used for this purpose. It is easily purified by fractional distillation and crystallization, which latter can be effected in large quantities by placing the benzene in a well-insulated container and allowing it to stand for a week or more in an atmosphere of from 0 to 30° F. A large percentage of the contaminating material can then be poured from the centre of the crystalline mass. Several such crystallizations will yield a very pure product. Thiophene may be removed by treatment with mercuric sulphate [25, 1919]. The freezing-point of 5.5° C is located in a very convenient working range.

In spite of its advantages, benzene is not sufficiently miscible with the higher molecular weight hydrocarbons, particularly paraffin wax, to be of value with the heavier fractions. It has been used on paraffin-base oils up to a molecular weight of 830 [7, 1932], but its use is not recommended for oils whose molecular weights are above 400 [28, 1923]. Below this value it is recommended as the best general-purpose solvent on all fractions which are, for practical purposes, liquid and non-volatile at its freezing-point except, of course, those which might contain benzene. Above 400, molecular association becomes quite pronounced, and a reliable extrapolation to infinite dilution, as described in a subsequent section, becomes difficult, particularly with paraffin-base oils.

Nitrobenzene. Several investigators [8, 1934, 26, 1930] have found in nitrobenzene a satisfactory solvent for molecular weight work. Association is not too pronounced and it may be purified in much the same manner as benzene. Nitrobenzene, however, is even less satisfactory than benzene for use with high molecular weight hydrocarbons. Gullick [10, 1931] has described the use of benzene on oils which were impossible to keep in solution in nitrobenzene. For oils below the light lubricating oil range, nitrobenzene appears to be a satisfactory solvent. Because of the proximity of their freezing-points it is a particularly convenient one to substitute for either benzene or cyclohexane on solutes which might contain those materials, thereby avoiding a change in the setting of the Beckmann thermometer.

Cyclohexane. This solvent has recently found considerable favour in cryoscopic work, the data of FitzSimons and Thiele [9, 1935] showing it to be better suited for samples containing paraffin wax than either benzene or nitrobenzene. This is probably its only advantage over these materials, the principal objection to it being the fact that its extremely low heat of fusion makes its freezing-point difficult to measure accurately, especially if somewhat impure, although its high cryoscopic constant does result in large freezing-point depressions. It, like benzene, may be present in some fractions of petroleum which would necessitate the substitution of another solvent in such cases.

Dioxane (1,4-dioxane dioxide). Recent work on this ether has disclosed the possibility of its use as a cryoscopic solvent. Its freezing-point and cryoscopic constant are very similar to those of benzene. Its solvent power for resins and some waxes is excellent, but its solvent power at its freezing-point for paraffin wax is not appreciably different from that of benzene. It has been used for hydrocarbon oils [1, 1926, 9, 1935], but appears to have no noteworthy advantages over benzene, and it does have the disadvantage of being completely miscible with water, thus necessitating the use of a dehydrating agent. It should be pointed out here that the use of dioxane as a dehydrating agent in pathological work indicates that its use in the ordinary molecular weight apparatus and method might be questionable, due to its hygroscopic nature.

Ethylene Bromide. Epperson and Dunlap [7, 1932] have reported excellent agreement in results obtained using nitrobenzene, benzene, and ethylene bromide. The latter showed the greatest solvent power for the oils and the least tendency to absorb moisture. This solvent should be investigated further and the results compared with values obtained by the ebullioscopic method.

Stearic Acid. Seaton and Sawyer [24, 1916] described the use of stearic acid as a solvent for molecular weight determinations on vegetable oils and acids. Later Mabery [16, 1923], using this solvent, reported molecular weights as high as 1,700 on residues from Appalachian crudes. Devine [5, 1929], however, found that stearic acid gave very low values as compared with other solvents, and that association increased with concentration in much the same manner as with benzene and other solvents, a factor which apparently was neglected by Mabery. It must be used with high concentrations of the solute in order to obtain accurate results, as the freezing-point of the material available for this purpose has been reported to be not sharper than 0.01° C. [24, 1916]. It is probably superior to naphthalene [23, 1927] or camphor [22, 1922], but its use can hardly be recommended for petroleum work until it has been investigated further. The ebullioscopic method probably

offers a better solution for measuring very high molecular weights than the cryoscopic method with stearic acid

Cryoscopic Apparatus.

In the cryoscopic determination the Beckmann method or a modification of it is ordinarily used. FitzSimons and Thiele [9, 1935] have used a modification of the original apparatus wherein the stirrer was actuated by a solenoid, the electrical circuit being opened and closed regularly by a conventional vacuum wind-shield wiper. A metronome has also been used for this purpose. It is advisable to use some form of mechanical agitation in order to eliminate errors due to variations in mechanical heat, and it is also preferable to make the freezing-point tube air-tight in order to exclude moist air. This can be effected by means of ground-glass joints, using a solenoid mounted on the cap of the tube to effect stirring. The thermometer may be sealed in the cap by means of a suitable cement, and solutes are added through another opening in the cap fitted with a ground-glass stopper. For precise work it is preferable to substitute a platinum resistance thermometer or a sensitive thermocouple for the Beckmann thermometer and to maintain a constant difference between the freezing-point of the solution and the temperature of the cooling-bath. For routine work, where this is not practicable, the freezing-point tube should be well insulated from the bath. The temperature difference for the latter case may be as high as 5° C, but for precise work should be not more than 1° C. A constant temperature throughout the bath is essential.

Solutes which volatilize appreciably at room temperature should be weighed out in a weighing pipette.

Cryoscopic Procedure.

While the actual procedure for the determination may be varied considerably, the following is recommended in order to bring out various precautionary measures which may influence the results materially.

A given volume of solvent, usually about 25 c.c., is pipetted into the freezing-point tube. If the temperature of the solvent is measured, the weight may be calculated from the density. The thermometer and stirrer are then placed in the tube and the whole placed in the freezing-bath and allowed to freeze while stirring. The solvent will supercool, and when crystallization starts the temperature will rise to the freezing-point and become constant. The thermometer is tapped sharply and the freezing-point recorded. The freezing-point tube is then removed from the bath and the solvent melted by warming with the hand, after which the freezing-point is again determined. This procedure is repeated until two successive readings differ by not more than 0.002° C. Due to absorption of water vapour from the air, a large number of determinations may be necessary before a constant value is reached. The air-tight apparatus described above is suggested to overcome this difficulty, but others have added dehydrating agents such as sodium sulphate to the solution. By this means a constant freezing-point is reached after two or three freezings. When precise measurements are being made it is desirable to add a small crystal of the solvent when a temperature of 0.1° C below the freezing-point has been reached. Supercooling is controlled in this way, and a constant and sufficiently small quantity of the pure solvent separates as crystals before the freezing-point is taken. Stead [26, 1930] used cooling curves to overcome this error. Such a curve is illustrated in Fig. 1, wherein the line *DE* is extrapolated to intersect *AC*, the point *B* being taken as the initial freezing-point. While

these curves probably give a close approximation of the true freezing-point, they should not be relied upon when precise measurements are desired.

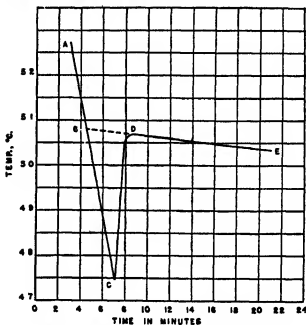

FIG. 1. Time-temperature curve for reducing errors caused by supercooling.

When the freezing-point of the solvent has been determined, a weight of solute, sufficient to give a freezing-point lowering of about 0.2° C, is added to the solvent and the freezing-point again determined as above. Usually only two freezings are necessary to obtain check readings. When this freezing-point has been recorded, another similar addition of solute is made, the procedure being repeated until the freezing-points of four concentrations of solute have been recorded.

It is essential that the freezing-point of the solvent be determined at the beginning of each determination.

Interpretation of Results.

In order to reduce the freezing-point equation to a form which permits simple and rapid calculation of results, several assumptions must be made. These are assumptions of conditions which exist at zero concentration or infinite dilution, and with their aid the equation may be reduced to the following form:

$$M = K_f \frac{S}{W \Delta t}$$

where *M* = molecular weight,

K_f = cryoscopic constant,

S = weight of solute,

W = weight of solvent,

Δt = freezing-point lowering in °C.

This formula is recommended for petroleum molecular weight work, and its use is justified by the fact that the final value for the molecular weight is a value taken at infinite dilution by extrapolation. Such an extrapolation is made by calculating the molecular weight by means of the above formula for each of at least four concentrations. The calculated values are then plotted against either the freezing-point depression or the concentration, and normally form a straight line which may be extrapolated to

infinite dilution or zero concentration. The value at this point is taken as the molecular weight. Most investigators have found that regardless of the equation used to calculate results, the apparent molecular weight varies with the concentration and that such an extrapolation of results is essential.

It should be pointed out here that in the case of a high molecular weight oil whose chemical structure is widely different from that of the solvent, such as a paraffin-base oil of 400 or higher molecular weight in benzene, it is sometimes very difficult to obtain a series of points which may be extrapolated with any degree of accuracy. In such cases the ebullioscopic method is preferable because association phenomenon is much less marked at the boiling-point of a solvent than at its freezing-point. The same is true of the heavier residues where high molecular weights determined by the cryoscopic method may be partly due to molecular aggregates. While these aggregates may not be completely broken down in the ebullioscopic method, they should be less marked at the higher temperature employed in this method.

The extrapolation is best carried out by making a calculation for each concentration, using the total weight of solute added to the pure solvent and the total depression. These values should be the sums of the several solute additions described previously. Such an extrapolation is shown in Fig. 2.

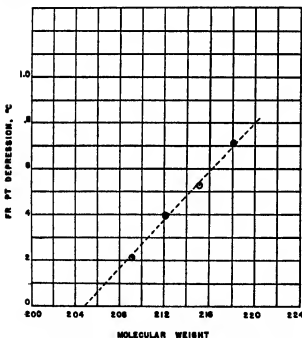

FIG. 2. Extrapolation of molecular weight determinations to infinite dilution.

Ebullioscopic Method

Many of the limitations which are inherent in the freezing-point method are not encountered in the ebullioscopic, or boiling-point, method. Among these may be mentioned (a) the formation of mixed crystals, (b) the low solubility of solute in solvent, and (c) excessive association, which is much less marked at the boiling-point than at the freezing-point.

Mair [17, 1935] has pointed out that recent developments in this field have eliminated many of the serious difficulties previously associated with the ebullioscopic method. His

excellent agreement in results obtained on two widely differing petroleum products and a number of pure compounds using three different solvents indicate that this method may be better suited for use on non-volatile petroleum products than the freezing-point method.

It must be remembered in this connection that the boiling-point method can be used, without troublesome corrections, only on fractions whose lightest components boil 150° C., or preferably 175° C. [19, 1921], above the boiling-point of the solvent used. For this reason the boiling-point method will probably never supplant the freezing-point method for use with the lighter fractions of petroleum. It can, however, be used to supplement the freezing-point method.

Ebullioscopic Solvents.

While the variety of solvents chosen for ebullioscopic work has been comparatively small, benzene has probably found more favour than any of the other solvents used. Carpenter [3, 1926] has used benzene, carbon tetrachloride, and chloroform for paraffin wax, and states that he obtained fairly consistent results, while Devine [5, 1929] obtained varying results on one oil using ethylene dichloride, benzene, and carbon tetrachloride. Mair [17, 1935], however, obtained excellent agreement on triphenylmethane, a very paraffinic oil, and a very naphthenic oil using benzene, *n*-hexane, and *iso*-octane as solvents.

While there is no consensus of opinion in favour of any particular solvent, it may be safely stated that benzene appears to be a satisfactory one for petroleum work and will continue to be widely used until some other is proved to be more suitable. It should be emphasized again that further research correlating the results of the various solvents in both the cryoscopic and ebullioscopic methods would greatly facilitate the selection of suitable solvents regardless of the method used.

While the boiling-point constants for various solvents are given in Table II, it is highly important that the constant for the solvent selected be determined experimentally before molecular weight determinations are made.

TABLE II
Physical Properties of Ebullioscopic Solvents

Solvent	Boiling-point, °C	K_b (boiling-point lowering for 1 g mol of solute in 1 g of solvent) °C	Reference
Benzene	79.6	2,622	[12]
<i>n</i> -Heptane	98.4		
<i>iso</i> -Octane	116.0		
Carbon tetrachloride	76.8	4,830	[12]
Ethylene dichloride	83.7	3,117	[12]
Chloroform	61.2	3,820	[12]

Ebullioscopic Apparatus.

Earlier equipment, designed by Beckmann [2, 1888], and widely used, consisted primarily of a boiling-point tube in which a Beckmann thermometer was immersed in the solution, a condenser for preventing the escape of the solvent from the boiling-point tube, a jacket surrounding the tube in which solvent was boiled to prevent loss of heat, and another condenser to condense the solvent in the jacket. Both the jacket and boiling-point tube were heated by a gas flame.

One of the chief sources of error associated with this apparatus was the uncertainty of the concentration of

solute in the solvent, brought about by the fact that a portion of the solvent (the amount depending upon the volume of the vapour space above the solution) exists as a pure vapour above the boiling solution. Washburn and Read [27, 1919] withdrew a portion of the boiling solution through a capillary side-neck and analysed this to obtain the concentration of solute. This is a tedious procedure and is to be avoided, if possible. Menzies and Wright [19, 1921] evaluated the quantity of vaporized solvent by filling the boiling-point with solvent to a constricted portion of the tube which was calibrated for volume. The solvent was brought to the boiling-point and after the vapour had filled the vapour space the source of heat was shut off, and as soon as boiling ceased the liquid level was read in the calibrated portion of the tube before the condensed vapour and liquid adhering to the walls drained into the liquid reservoir. Mair [17, 1935] has evaluated this error in probably the simplest manner by maintaining a constant heat supply to the apparatus in order to effect a constant vaporization of solvent and calibrating the apparatus with substances of known molecular weight.

Immersion of the thermometer in the boiling solution is associated with large errors due to superheating. These errors have been almost entirely eliminated by the development of the Cottrell boiler [4, 1919] and internal electrical heating units. The Cottrell boiler (see Fig. 3) consists of a

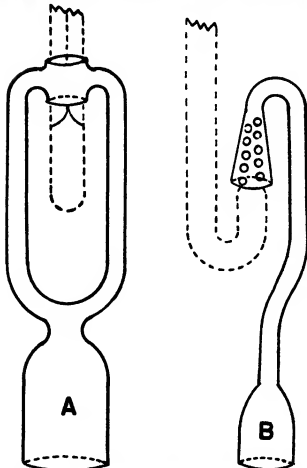

Fig. 3 Cottrell boilers, A, for Beckmann thermometer, B, for Menzies-Wright differential thermometer

small percolator arrangement which pumps the boiling liquid up on to the bulb of the thermometer. The thermo-

meter is suspended in the vapour above the liquid level and thereby indicates the temperature of the two phases in equilibrium. The use of the internal heater described by Pearce and Hicks [21, 1926] was improved by Mair [17, 1935] who controlled the energy input in order to maintain a constant vaporization of solvent.

Pearce and Hicks [21, 1926] used a thermocouple for temperature measurement, thus eliminating the errors due to thermometry. Washburn and Read [27, 1919] used two boilers, one for the pure solvent and one for the solution, in order to correct for changes in barometric pressure, and Menzies and Wright [18, 1921] eliminated both of these errors by the development of the differential thermometer (see Fig. 4). This ingenious device, instead of measuring the temperature of the solution, measures the temperature differential between the vapour and the liquid, thus compensating for any changes that take place in the boiling-point of the pure solvent during the determination and at the same time eliminating many of the errors common to mercurial thermometers.

A combination of the Cottrell boiler, the internal heater, and the differential thermometer produces an ebullioscopic apparatus which rivals that of the freezing-point method in its ease of manipulation as well as its precision. Such a method is undoubtedly better suited for higher molecular weight determinations than the cryoscopic method.

While this combination is desirable it would be entirely erroneous to assume that it is necessary in order to obtain satisfactory results with the boiling-point method. The use of the Cottrell boiler is essential, but reasonably accurate results may be obtained using the Cottrell boiler with a Beckmann thermometer or a sensitive thermocouple, employing a gas flame for the heat supply, if the proper technique is employed. The availability of such refinements as the differential thermometer and controlled electrical heating will necessarily govern the investigator in his selection of equipment.

Ebullioscopic Procedure.
In general, the procedure to be followed in the boiling-point method is similar to that used in the cryoscopic method. A particular procedure is difficult to specify, however, because of its dependence on the type of apparatus employed.

When a Beckmann thermometer or a thermocouple is used it is very important to compensate for any changes in the boiling-point of the pure solvent during the determination. This may be done by corrections obtained from changes in barometric pressure or by the method of Washburn and Read [27, 1919], wherein two similar boiling tubes are used, one containing pure solvent and the other the solution.

Regardless of the apparatus selected it is essential that the amount of solvent present as vapour be carefully evaluated, and that superheating be eliminated at the point where the temperature of the boiling solution is taken. These factors are discussed briefly under the previous heading, and for a



Fig. 4 Menzies-Wright differential thermometer

more detailed discussion of their application and the procedure to be followed for specific equipment the reader is referred to the references therein

Interpretation of Results.

Reduction of the boiling-point equation may be effected in the same manner as is used in the freezing-point equation to yield a simplified formula for rapid calculation of results. The simplified equation is

$$M = K_B \frac{S}{W \Delta t}$$

where M = molecular weight of the solute,
 K_B = boiling-point constant,
 S = weight of solute,
 W = weight of solvent,
 Δt = boiling-point elevation

As in the cryoscopic method, this equation may be used when results are extrapolated to infinite dilution, the extrapolation being the same as that described for the cryoscopic method. The determination of boiling-point constants as well as molecular weights should be made by means of this extrapolation

Vapour-density Method

A few recent investigators have chosen the Victor Meyer method for petroleum molecular weight work. As will be remembered, this method consists of vaporizing a known weight of sample in a tube immersed in a constant temperature bath and measuring the volume of air displaced into a gas-measuring burette

Mildred Hicks-Bruun [11, 1930] has described a modified apparatus designed to prevent diffusion of the hydrocarbon vapour into the gas burette, with subsequent condensation, and has minimized the errors due to deviations from the ideal gas laws by carrying out the measurements at two pressures and making use of Berthelot's method of limiting densities. She reports determinations on four pure, or nearly pure, hydrocarbons. Average deviations from the true molecular weight of from 0.6 to 0.14% are reported. No work was reported on hydrocarbon mixtures, however

Newman and Means [20, 1935] have added to this equipment the Baro burette, a very accurate gas-measuring device, and by making determinations at several pressures have extrapolated the molecular weight graphically to zero pressure without recourse to van der Waal's or Berthelot's equations. They report excellent agreement with theoretical values for seven pure compounds, and compare the results obtained by this method on gasoline fractions with results obtained using the cryoscopic method with benzene as a solvent. The method gave results of the order of 2 to 3% lower than the cryoscopic method. Unfortunately, too few experimental details on either the vapour-density or cryoscopic methods are included to make possible a sound evaluation of the method

One of the chief objections to this method for general use is the fact that the sample under observation must be completely vaporized. For this reason the method is limited to

the lighter fractions, and the determination should be preceded by a careful fractionation. The use of low pressures is an aid in this respect, but is limited in its application by errors caused by diffusion. At present the method cannot claim the versatility that is exemplified in either the cryoscopic or ebullioscopic method

Obviously the Victor Meyer method is well adapted for use on petroleum fractions whose volatility is high enough to give rise to errors in the cryoscopic procedure

When the sample is a gas at ordinary temperatures the molecular weight may be obtained from a direct gas-density determination. This may be obtained by various methods, the method of Edwards [6, 1917] being one of the best

Summary

The cryoscopic method with benzene as a solvent is recommended for general use in determining the molecular weights of liquid solutes up to a molecular weight of 400, except on fractions which might contain benzene. Nitrobenzene or cyclohexane may be substituted for benzene under special conditions or even for general use, if desired. Stearic acid is claimed to be a satisfactory solvent for higher molecular weights, but until more experimental work is reported it can hardly be recommended as a satisfactory substitute for any of the above solvents or the ebullioscopic method

The conventional type of apparatus in the cryoscopic method is satisfactory if recent innovations, such as mechanical stirring and some method of preventing the absorption of water by the solvent, are included. The use of a platinum resistance thermometer is recommended, although not essential. The use of cooling curves in obtaining freezing-points is suggested in cases where high accuracy is not necessary, whereas the determination of the cryoscopic constant of each solvent using several types of pure compounds is essential in all cases. All results, including the determination of the constant, should be obtained by extrapolating the molecular weight to infinite dilution

The ebullioscopic method with benzene as the solvent is recommended for molecular weights of 400 or above, although benzene may be replaced by hexane, cyclohexane, iso-octane, carbon tetrachloride, or other similar solvents. The use of the Menzies-Wright differential thermometer and carefully controlled electrical heating are preferred, and the use of a Cottrell boiler is essential. As in the cryoscopic method, the determination of the ebullioscopic constant of the solvent using several types of pure compounds is recommended as well as the extrapolation of all experimental results to infinite dilution

Recent improvements in the Victor Meyer vapour-density method are discussed, but until more experimental details and results are published, the method is not recommended as a substitute for either the cryoscopic or ebullioscopic methods except in cases where the volatility of the sample precludes the use of the cryoscopic method. For gas mixtures a density determination by the Edwards method is recommended

REFERENCES

- 1 ANSCHÜTZ, L., and BROEGER, *W. Ber.* 59 n, 2844 (1926)
- 2 BECKMANN, E. *Z. phys. Chem.* 2, 638 (1888)
- 3 CARPENTER, J. A. *J. I. P. T.* 12, 288 (1926)
- 4 COFFRELL, F. G. *J. A. C. S.* 41, 721 (1919)
- 5 DEVLIN, J. M. *Univ. Okla. Bull.* 9, 131 (1929)
- 6 EDWARDS, J. D. *Technologic Papers of the U. S. Bureau of Standards*, no. 89, 23 Feb. 1917
- 7 EFFERSON, E. R., and DUNLAP, H. L. *Ind. Eng. Chem.* 24, 1369 (1932)
- 8 FENKEL, M. R., McCLELLAN, W. B., and CANNON, M. R. *Ind. Eng. Chem.* 26, 976 (1934)

DETERMINATION OF THE MOLECULAR WEIGHTS OF PETROLEUM FRACTIONS 1301

- | | |
|---|--|
| <p>9 FITZSIMONS, O., and THEILE, E W <i>Ind Eng Chem, Anal Ed</i> 7, 11 (1935)</p> <p>10 GULLACK, N G <i>J I P T</i> 17, 541 (1931)</p> <p>11 HICKS-BAUDIN, M M <i>Bur Stand J Res</i> 5, 575 (1930)</p> <p>12 <i>International Critical Tables</i>, 3, 324</p> <p>13 ———— 4, 183</p> <p>14 KLAUS, C A and VINGEE, R A <i>J A C S</i> 56, 511 (1934)</p> <p>15 LERER, M <i>Ann Comb</i> <i>by</i> 9, 511 (1934)</p> <p>16 MABERY, C F <i>Ind Eng Chem</i> 15, 1233 (1923)</p> <p>17 MAIR, J <i>Bur Stand J Res</i> 14, 345 (1935)</p> <p>18 MENZIES, A W C and WRIGHT, S L <i>J A C S</i> 43, 2309 (1921)</p> | <p>19 MENZIES, A W C and WRIGHT, S L <i>J A C S</i> 43, 2314 (1921)</p> <p>20 NEWMAN and MEANS <i>Refiner</i>, 14, 432 (1935)</p> <p>21 PEARCE, J N and HICKS, M M <i>J Phys Chem</i> 30, 1678 (1926)</p> <p>22 RABT, K <i>Ber</i> 55, 1051 (1922)</p> <p>23 RHODES, F A, MASON, C W, and SUTTON, R W <i>Ind Eng Chem</i>, 19, 935 (1927)</p> <p>24 SEATON, M Y and SAWYER, G B <i>Ind Eng Chem</i> 8, 490 (1916)</p> <p>25 SPIELMANN, P E and JONES, F B <i>J S C I</i> 38, 188 (1919)</p> <p>26 STEED, A H <i>J I P T</i> 16, 799 (1930)</p> <p>27 WASHBURN, E W and READ, J W <i>J A C S</i> 41, 729 (1919)</p> <p>28 WILSON, R E., and WYLDIE, E P <i>Ind Eng Chem</i> 15, 801 (1923).</p> |
|---|--|

THE PROPERTIES OF PURE HYDROCARBONS

By G. L. EATON, M.Sc.

Senior Engineer, Atlantic Refining Company

I. NOMENCLATURE AND STRUCTURE.

The nomenclature used in this section is based upon the *Definitive Report of the Commission on the Reform of the Nomenclature of Organic Chemistry* adopted by the International Union of Chemistry at Liège in 1930. An excellent discussion of this report has been prepared by A. M. Patterson and is published in the *Handbook of Chemistry and Physics*, pp. 486-97, 20th ed., Chemical Rubber Publishing Company, 1935.

The following will serve as a guide in using the tables

1. Names of Saturated Open-chain Hydrocarbons

The numeral before the name refers to the number of carbon atoms in the chain

1 Methane	33 Tritracontane
2 Ethane	34 Tetratriacontane
3 Propane	35 Pentatriacontane
4 Butane	36 Hexatriacontane
5 Pentane	37 Heptatriacontane
6 Hexane	38 Octatriacontane
7 Heptane	39 Nonacontane
8 Octane	40 Tetratriacontane
9 Nonane	41 Hentetracontane
10 Decane	42 Dotetracontane
11 Hendecane (Undecane)	43 Tritetracontane
12 Dodecane	44 Tetraetracontane
13 Tridecane	45 Pentetracontane
14 Tetradecane	46 Hexetracontane
15 Pentadecane	47 Heptetracontane
16 Hexadecane	48 Octaetracontane
17 Heptadecane	49 Nonacontane
18 Octadecane	50 Pentacontane
19 Nonadecane	51 Hentriacontane
20 Eicosane	52 Doptriacontane
21 Heneicosane	53 Tripentacontane
22 Docosane	54 Tetrapentacontane
23 Tricosane	55 Pentapentacontane
24 Tetracosane	56 Hexapentacontane
25 Pentacosane	57 Heptapentacontane
26 Hexacosane	58 Octapentacontane
27 Heptacosane	59 Nonapentacontane
28 Octacosane	60 Hexacontane
29 Nonacosane	61 Henthexacontane
30 Triacontane	62 Dohexacontane
31 Hentriacontane	63 Tribhexacontane
32 Dotriacontane	64 Tetrahexacontane

2. Name Endings.

- Saturated hydrocarbons have the ending *ane*
- Open-chain unsaturated hydrocarbons have the ending *ene*. With two double bonds the ending is *diene*, with three double bonds *triene*
- Triple-bonded compounds have the ending *yne*.
- With both double and triple bonds in the fundamental chain the ending is *enyne*, *dienyne*, &c
- Saturated monocyclic hydrocarbons have the name of the corresponding open-chain saturated hydrocarbon preceded by the prefix *cyclo*
- Aromatic hydrocarbons are given the ending *ene*

3. Numbering

In aliphatic compounds the carbon atoms of the fundamental chain will be numbered from one end to the other with the use of arabic numerals. In case of ambiguity the

lowest numbers will be given (1) to the principal function, (2) to double bonds, (3) to triple bonds, (4) to atoms or radicals designated by prefixes. The expression "lowest numbers" signifies those that include the lowest individual number or numbers. Thus, 1,3,5 is lower than 2,4,6, 1,5,5 lower than 2,6,6, 1,2,5 lower than 1,4,5, 1,1,3,4 lower than 1,2,2,4.

Examples $\text{CH}_2=\text{CHCH}_2\text{CH}_3$, 1-Butene (not 3-Butene),
 $\text{CH}_2=\text{CHC}(\text{CH}_3)_2$, 1-Buten-3-yne (not 3-Buten-1-yne)

Numbers are placed before the name to which they refer. Positions in a side chain will be designated by numerals or letters, starting from the point of attachment. The numerals or letters will be in parentheses with the name of the chain.

Example $\text{CH}_3\text{CH}_2(\text{CH}_2)_3\text{CH}_3$ —(1-Methylpropyl)

Numbering of cyclic compounds is given in the table of structural formulae for each of the basic hydrocarbons.













4. Prefix Names of Radicals.











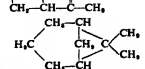
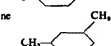
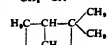

Acenaphthyl (from Acenaphthene)	C_{10}H_7 —
Acetyl — Ethynyl	
Allyl — 2-Propenyl	
β -Allyl — Isopropenyl	
pseudo-Allyl — Isopropenyl	
Amyl	$\text{CH}_2(\text{CH}_2)_4$ —
tert-Amyl	$(\text{C}_2\text{H}_5)(\text{CH}_2)_2\text{C}$ —
Amylids	$\text{CH}_2(\text{C}_2\text{H}_5)_2\text{CH}=\text{C}$
Anthryl (from Anthracene, 3 isomers)	C_{14}H_9 —
Anthrylene (from Anthracene, 11 isomers)	
Benzyl	C_6H_5 —
Benzylidene	$\text{C}_6\text{H}_5\text{CH}=\text{C}$
Benzoyl	$\text{C}_6\text{H}_5\text{C}=\text{O}$
Benzohydril	$(\text{C}_6\text{H}_5)_2\text{CH}$ —
Benzohydrilidene — Diphenylmethylen	
Benzyl	$\text{C}_6\text{H}_5\text{CH}_2$ —
Benzylidene — Benzal	
Bornyl (from Borneol)	$\text{C}_{10}\text{H}_{17}$ —
1-Butenyl	$\text{CH}_2\text{CH}(\text{CH}=\text{CH})$ —
Butyl	$\text{CH}_2(\text{CH}_2)_3$ —
sec-Butyl	$(\text{C}_2\text{H}_5)(\text{CH}_2)\text{CH}$ —
tert-Butyl	$(\text{CH}_3)_3\text{C}$ —
Butylidene	$\text{CH}_2(\text{CH}_2)_3\text{CH}=\text{C}$
Camphanyl (from Camphane, 3 isomers)	$\text{C}_{10}\text{H}_{17}$ —
Carvacryl (from Carvacrol)	$\text{C}_{10}\text{H}_{15}$ —
Cetyl	$\text{CH}_3(\text{CH}_2)_{14}\text{CH}_2$ —
Cinnamyl	$\text{C}_6\text{H}_5\text{CH}=\text{CHCH}_2$ —
Cinnamylidene — Styryl	
Cinnamylidene — Cinnamal	
Citral (from Citraldehyde)	$\text{C}_9\text{H}_{15}\text{CH}=\text{C}$
Cumyl	$p\text{-(CH}_3)_2\text{CHC}_6\text{H}_4$ —
Cumenyl	$(\text{CH}_3)_2\text{CHC}_6\text{H}_4$ —
Cuminal — Camal	
Cyclobutyl	$\text{CH}_2\text{CH}_2\text{CH}_2\text{CH}_2$ —
Cyclohexadienyl (2,4, &c)	C_6H_7 —
Cyclohexadienylidene (2,4, &c)	C_6H_7 —
Cyclohexenyl (from Cyclohexene, 3 isomers)	C_6H_9 —
Cyclohexyl (from Cyclohexane)	C_6H_{11} —
Cyclohexylidene	$\text{CH}_2\text{CH}_2\text{CH}_2\text{CH}_2\text{CH}_2\text{C}=\text{C}$
Cyclopentenyl (from Cyclopentene)	C_5H_7 —
Cyclopentyl (from Cyclopentane)	C_5H_{11} —
Cyclopropyl	$\text{CH}_2\text{CH}_2\text{CH}_2$ —
Cymyl (from Cymene)	$\text{C}_{10}\text{H}_{15}$ —
2-p-Cymyl — Carvacryl	
3-p-Cymyl — Thymyl	

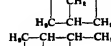
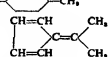
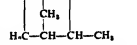
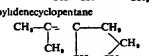
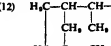
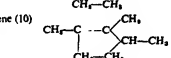
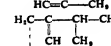
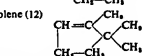
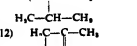
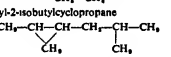
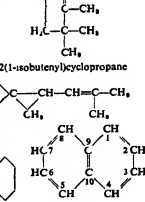
Duryl	2,3,5,6-(CH ₃) ₄ C ₆ H—
Durylene	2,3,5,6-(CH ₃) ₄ C ₆ =
Ethynyl	CH≡CH—
Ethylenidene	CH ₂ =C=
Ethyl	CH ₃ CH ₂ —
Ethylidene	CH ₂ CH ₂ =
Ethylidyne	CH ₃ C≡
Ethynyl	C≡C—
Fenchyl (from Fenchyl Alcohol)	C ₁₀ H ₁₇ —
Fluoryl (from Fluorene, 5 isomers)	C ₁₀ H ₇ —
Fluorylidene	C ₁₀ H ₅ =
Geranyl (from Geraniol)	C ₁₀ H ₁₇ —
Hendecyl	CH ₃ (CH ₂) ₁₀ —
Heptyl	CH ₃ (CH ₂) ₆ —
Hexadecyl = <i>Cetyl</i>	CH ₃ (CH ₂) ₁₅ —
Hexyl	CH ₃ (CH ₂) ₅ —
Indanyl (from Indan, 4 isomers)	C ₉ H ₇ —
Indenyl (from Indene, 7 isomers)	C ₉ H ₇ —
Isoallyl = <i>Propenyl</i>	(CH ₂) ₂ CHCH ₂ CH ₂ —
Isoamyl	(CH ₂) ₄ CH(CH ₃)CH ₂ —
Isoamylidene	(CH ₂) ₄ CH(CH ₃)C=
1-Isobutenyl	(CH ₂) ₃ C=C—CH ₃
Isobutyl	(CH ₃) ₂ CHCH ₂ —
Isohexyl	(CH ₃) ₂ CH(CH ₂) ₃ —
1-Isopentenyl	(CH ₃) ₂ CHCH(CH ₃)C=
Isopropenyl	CH ₂ =C(CH ₃)CH ₂ —
Isopropyl	(CH ₃) ₂ CH—
Isopropylidene	(CH ₃) ₂ C=
Menthyl (from Menthane) as 2-p-	C ₁₀ H ₁₇ —
Menthyl	3,5-(CH ₃) ₂ C ₁₀ H ₁₇ —
2-Mesityl	2,4,6-(CH ₃) ₃ C ₆ H ₂ —
Methene	<i>Methylen</i>
Methenyl = <i>Methylenidene</i>	CH ₂ —
Methyl	CH ₃ —
Methylidene	CH ₂ =
Methylidyne	CH≡
Naphthyl	C ₁₀ H ₇ CH ₂ —
Naphthylidene	C ₁₀ H ₆ C=
Naphthobenzyl	C ₁₀ H ₇ CH ₂ —
Naphthyl (1 or 2)	C ₁₀ H ₇ —
Naphthylene	C ₁₀ H ₆ =
Naphthylidene (1(4) form shown)	C ₁₀ H ₅ C=
Norcamphanyl (from Norcamphane)	C ₁₀ H ₁₇ —
Ocyl	CH ₂ (CH ₂) ₂ —
1-Pentenyl	CH ₂ (CH ₂) ₃ CH=CH—
Phenyl = <i>Amyl</i>	CH ₂ (CH ₂) ₃ CH ₂ CH=CH—
Phenanthryl (from Phenanthrene 5 isomers)	C ₁₄ H ₉ —
Phenanthrylene (several isomers)	C ₁₄ H ₆ =
Phenyl (<i>s</i> , <i>o</i> -, <i>p</i> -)	C ₆ H ₅ —
Phenethyl	C ₆ H ₅ CH ₂ CH ₂ —
Phenyl	C ₆ H ₅ —
Phenylene (<i>o</i> -, <i>m</i> -, <i>p</i> -)	C ₆ H ₄ =
Propargyl = 2-Propynyl	CH ₃ CH=CH—
1-Propenyl	CH ₂ CH=CH—
1-Propenyldene	CH ₂ CH=C=
Propyl	CH ₂ CH ₂ CH ₂ —
Propylidene	CH ₂ CH ₂ CH=
2-Propynyl	CH≡C—CH ₂ —
Styryl	C ₆ H ₅ CH=CH—
Thymyl (from Thymol)	C ₁₀ H ₁₇ —
Tolyl (<i>o</i> -, <i>m</i> -, <i>p</i> -)	CH ₃ C ₆ H ₄ —
α-Tolyl = <i>Benzyl</i>	CH ₃ C ₆ H ₄ —
Tolylene (6 isomers)	CH ₃ C ₆ H ₄ =
α-Tolylene = <i>Benzal</i>	
Undecyl = <i>Hendecyl</i>	
Vinyl = <i>Ethenyl</i>	
Vinylidene = <i>Ethylenidene</i>	
Xylyl (Dimethylphenyl)	(CH ₃) ₂ C ₆ H ₄ —

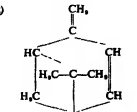
Table of Structural Formulae

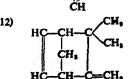
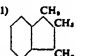
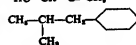

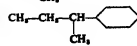
Ref no	Formula
5	C ₂ H ₂ Acetylene HC≡CH
8	C ₃ H ₄ Propadiene CH ₂ =C=CH ₂
9	C ₃ H ₄ Propyne CH≡C—CH ₃

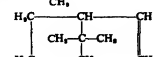
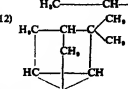
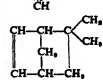
Ref no	Formula
10	C ₃ H ₄ Cyclopropane 
13	C ₄ H ₆ Butadiyne HC≡C—C≡CH
14	C ₄ H ₆ 3-But, n-1-yne HC≡C—C=CH ₂
15	C ₄ H ₆ Cyclobutene 
16	C ₄ H ₈ 1,2-Butadiene CH ₂ =C=C—CH ₂
17	C ₄ H ₈ 1,3-Butadiene CH ₂ =CH—CH=CH ₂
18	C ₄ H ₈ 1-Butyne HC≡C—CH ₂ —CH ₃
19	C ₄ H ₈ 2-Butyne CH ₃ —C≡C—CH ₃
20	C ₄ H ₈ Cyclobutane 
21	C ₅ H ₈ Methylcyclopropane 
22	C ₅ H ₈ 1-Butylene CH ₂ =CH—C(CH ₃) ₂ —CH ₃
24	C ₅ H ₈ Isobutylene CH ₂ =C(CH ₃)—CH ₂ —CH ₃
26	C ₅ H ₁₀ Isobutane 
27	C ₅ H ₈ 1,3-Cyclopentadiene 
28	C ₆ H ₈ 3-Methyl-3-buten-1-yne HC≡C—C(CH ₃)=CH ₂
51	C ₆ H ₆ Benzene (also) 
52	C ₆ H ₈ 1,5-Hexadien-3-yne CH ₂ =CH—C≡C—CH=CH ₂
54	C ₆ H ₈ 1,2-Dihydrobenzene 
59	C ₆ H ₁₀ Methylene-cyclopentane 
92	C ₇ H ₈ 1,3,5-Cycloheptatriene 
93	C ₇ H ₈ Toluene (also) 
94	C ₇ H ₁₀ 1,2-Dihydrotoluene 
102	C ₇ H ₁₀ Ethylidenecyclopentane 
121	C ₇ H ₁₂ 1-Methyl-2-isopropylcyclopropane
154	C ₈ H ₈ Ethynylbenzene

Ref. no	Formula	Ref. no	Formula
155	C_8H_8 Styrene $CH_2=CH-$ 	248	C_8H_{14} Santene (12) 
157	C_8H_{10} <i>o</i> -Xylene 	255	C_8H_{10} Nopinane (1) 
158	C_8H_{10} <i>m</i> -Xylene 	256	C_8H_{10} Camphenilene (12) 
159	C_8H_{10} <i>p</i> -Xylene 	257	C_8H_{10} Santene (12) 
160	C_8H_{10} Dimethylfulvene 	258	C_8H_{10} Apofenchene (12) 
179	C_8H_{14} Isopropylidencyclopentane 	259	C_8H_{10} Pulegone (11) 
180	C_8H_{14} Laurole (10) 	263	$C_{10}H_{18}$ Campholene (12) 
181	C_8H_{14} Isolaurole (12) 	264	$C_{10}H_{18}$ 1,1-Dimethyl-2(1-isobutenyl)cyclopropane 
204	C_8H_{14} 1-Methyl-2-isobutylcyclopropane 	298	$C_{10}H_8$ Naphthalene (also) 
230	C_9H_8 Indene 	308	$C_{10}H_{14}$ Verbenene (12) 
231	C_9H_8 (1-Propenyl)benzene $CH_2=C=CH-$ 	309	$C_{10}H_{14}$ Camphinene (12) 
232	C_9H_{10} Hydrindene (1) 	311	$C_{10}H_{14}$ Isobutylbenzene 
233	C_9H_{10} (1-Propenyl)benzene $CH_2=CH=CH-$ 	312	$C_{10}H_{14}$ <i>sec</i> -Butylbenzene 
234	C_9H_{10} (2-Propenyl)benzene $CH_2=CH-CH_2-$ 		
235	C_9H_{10} Isopropenylbenzene $CH_2=C(CH_3)-$ 		
244	$C_{12}H_{14}$ Apobornylene (12) 		
245	$C_{11}H_{14}$ Apocylene (12) 		
246	C_9H_{14} Camphenilene (2) 		

Ref no	Formula		Ref no	Formula	
313	$C_{10}H_{14}$	tert-Butylbenzene	340	$C_{10}H_{16}$	$\Delta^4\alpha\beta$ - <i>m</i> -Menthadiene
314	$C_{10}H_{14}$	<i>o</i> -Cymene (2)	341	$C_{10}H_{16}$	$\Delta^4\beta\gamma$ - <i>m</i> -Menthadiene
330	$C_{10}H_{16}$	Camphlene (structure uncertain)	342	$C_{10}H_{16}$	α -Terpinene (11)
331	$C_{10}H_{16}$	Cryptotaenene (structure not certain) (11)	343	$C_{10}H_{16}$	β -Terpinene (11)
332	$C_{10}H_{16}$	Geraniene (structure uncertain)	344	$C_{10}H_{16}$	γ -Terpinene (11)
333	$C_{10}H_{16}$	Terpinylene (structure not known) (11)	345	$C_{10}H_{16}$	α -Phellandrene (11)
334	$C_{10}H_{16}$	β -Octalin (1)	346	$C_{10}H_{16}$	β -Phellandrene (11)
335	$C_{10}H_{16}$	α -Pinene (12)			
336	$C_{10}H_{16}$	β -Pinene (12)			
337	$C_{12}H_{18}$	Δ^4 -Carene (12)			
338	$C_{12}H_{18}$	Δ^4 -Carene (11)			
339	$C_{12}H_{18}$	Sylvestrene (11)			

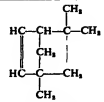
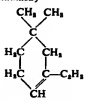
Ref no	Formula		Ref no	Formula	
347	$C_{10}H_{16}$	Terpinolene (11)	354	$C_{10}H_{16}$	Cyclofenchene (12)
348	$C_{10}H_{16}$	Limonene (11)	355	$C_{10}H_{16}$	Tricyclene (12)
349	$C_{10}H_{16}$	Isolimonene (11)	356	$C_{10}H_{16}$	Isotricyclene (12)
350	$C_{10}H_{16}$	Δ^8 <i>trans</i> -p-Menthadiene (6)	357	$C_{10}H_{16}$	Bornylene (10)
351	$C_{10}H_{16}$	α -Thujene (11)	358	$C_{10}H_{16}$	Camphene (12)
352	$C_{10}H_{16}$	β -Thujene (12)	359	$C_{10}H_{16}$	Endocamphene (12)
353	$C_{10}H_{16}$	Sabinene (11)	360	$C_{10}H_{16}$	α -Fenchene (12)
			361	$C_{10}H_{16}$	β -Fenchene (12)
			362	$C_{10}H_{16}$	γ -Fenchene (12)

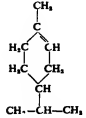
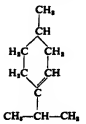
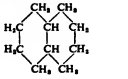
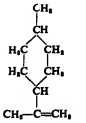
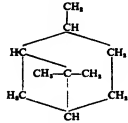
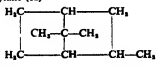
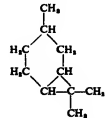
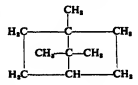
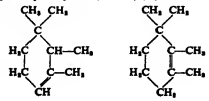
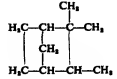
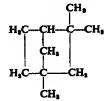



Ref no	Formula		Ref no	Formula	
363	$C_{12}H_{18}$	β -Fenchene (12)	374	$C_{12}H_{18}$	(continued)
					
365	$C_{12}H_{18}$	1,2-Di-isopropylidene-cyclobutane (6)	378	$C_{12}H_{18}$	Δ^4 - p -Menthene (11)
					
368	$C_{12}H_{18}$	Myrcene (11)	379	$C_{12}H_{18}$	Δ^8 - p -Menthene (11)
		$CH_2=C(CH_3)-CH=CH-CH_2-CH=C(CH_3)-CH=CH_2$			
369	$C_{12}H_{18}$	Ocimene (11)			
		$CH_2=C(CH_3)-CH_2-CH=CH-CH=C(CH_3)-CH=CH_2$			
370	$C_{12}H_{18}$	Allo-ocimene			
		$CH_2=C(CH_3)-CH=CH-CH_2-CH=C(CH_3)-CH=CH_2$ (2)			
		$CH_2=C(CH_3)-CH=CH-C(CH_3)=CH-CH_2$ (11)			
371	$C_{12}H_{18}$	Decahydronaphthalene	381	$C_{12}H_{18}$	Dihydrolimonene (11)
					
372	$C_{12}H_{18}$	Pinane (12)	383	$C_{12}H_{18}$	Isobornylane (12)
					
373	$C_{12}H_{18}$	Carane (11)	384	$C_{12}H_{18}$	Camphane (12)
					
374	$C_{12}H_{18}$	Cyclodihydromyrcene (mixture) (11)	385	$C_{12}H_{18}$	Isocamphane (12)
					
			386	$C_{12}H_{18}$	Fenchene (12)
					

Ref no	Formula	Ref no	Formula
387	$C_{10}H_{18}$ Thujane (12) 	437	$C_{11}H_{18}$ 3,4-Dimethylcumene (2)
392	$C_{10}H_{18}$ Cihydromyrene (11) $CH_2=C(CH_3)-CH=CH-CH_2-CH_2-C(CH_3)=CH-CH_2$	440	$C_{11}H_{18}$ Norbornylcyclohexane (12)
393	$C_{10}H_{18}$ tert-Butylcyclohexane (6) 	441	$C_{11}H_{18}$ Methyl 8-fenchene (12)
395	$C_{10}H_{18}$ o-Menthane (6) 	449	$C_{10}H_{18}$ Acenaphthylene (2)
399	$C_{12}H_{18}$ Isothujane (12) 	450	$C_{12}H_{18}$ Diphenylene (2)
418	$C_{12}H_{18}$ 1-Methylnaphthalene 	451	$C_{12}H_{18}$ Acenaphthene (2)
419	$C_{12}H_{18}$ 2-Methylnaphthalene 	452	$C_{12}H_{18}$ Diphenyl (2)
422	$C_{12}H_{18}$ (1-Methylbutyl)benzene $CH_2-CH(CH_2-CH_2-CH_2)-CH_2-CH_2$ 	483	$C_{12}H_{18}$ Fluorene (10)
423	$C_{12}H_{18}$ tert-Amylbenzene (2) 	$C_{12}H_{18}$ Methylphenylfulvene (6) 	
428	$C_{12}H_{18}$ o-tert-Butyltoluene (2) 	488	$C_{12}H_{18}$ Irene (11)

Ref no	Formula		Ref no	Formula	
	$C_{12}H_{18}$	Ionene (11) 	521	$C_{12}H_{24}$	Dodecahydroanthracene (6)
	$C_{12}H_{18}$	α -Ionane (11) 	522	$C_{12}H_{18}$	Dodecahydrophenanthrene (6)
496	$C_{14}H_{10}$	Anthracene 	525	$C_{12}H_{18}$	Fluoranthene (10)
497	$C_{12}H_{10}$	Phenanthrene 	526	$C_{12}H_{18}$	Succisterene (structure not known)
498	$C_{12}H_{18}$	Diphenylacetylene 	540	$C_{12}H_{18}$	1-Ethyl-4-benzylbenzene
501	$C_{12}H_{18}$	1,1-Diphenylethylene 	541	$C_{12}H_{18}$	Di-p-tolymethane
502	$C_{12}H_{18}$	1,2-Diphenylethylene 	542	$C_{12}H_{18}$	Azulene (2) (structure not known)
505	$C_{12}H_{18}$	m-Benzyltoluene 	543	$C_{12}H_{18}$	Guiazulene (12) (structure not known)
510	$C_{12}H_{18}$	α,α' -Ditolyl 	544	$C_{12}H_{18}$	Cadalene (2)
511	$C_{12}H_{18}$	α,m -Ditolyl 	548	$C_{12}H_{18}$	Calamenene (12) (structure not known)
	$C_{12}H_{18}$	Eudalene (12) 	549	$C_{12}H_{18}$	Aromadendrene (12) (structure not known)
517	$C_{12}H_{18}$	Apocadalene (2) 	550	"	Atractylene (2)
518	$C_{14}H_{10}$	Decahydroanthracene (6) 	551	"	Calamene (12)
			552	"	Cannibene
			553	"	Cedrene (12)
			554	"	Clovene (12)
			555	"	α -Costene (12)
			556	"	β -Costene (12)
			557	"	α -Curcumene (12)
			558	"	β -Curcumene (12)
			559	"	Guaiene (12)
			560	"	Guaiene
			561	"	α -Gurjunene (12)
			562	"	β -Gurjunene (12)
			563	"	Humulene (12)
			564	"	Isocadinene (12)
			565	"	Isoclovene (12)
			566	"	Ledene (12)
			567	"	Longifolene (12)
			568	"	Patschoulene (12)
			569	"	Sequictronellene (6)
			570	$C_{12}H_{18}$	Cadinene (12)

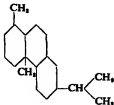
Ref no	Formula		Ref no	Formula	
593	$C_{13}H_{22}$	Dihydrocadimene (12)	602	$C_{13}H_{22}$	Tetrahydrocadimene (12) (same structure)
594	$C_{13}H_{22}$	Dihydroeudesmene (12)	603	$C_{13}H_{22}$	Tetrahydroeudesmene (12)
595	$C_{13}H_{22}$	Dihydrocopaene (12)	604	$C_{13}H_{22}$	Tetrahydrocopaerylene (12)
596	$C_{13}H_{22}$	Dihydrozingerene (12)	605	$C_{13}H_{22}$	Tetrahydrozingerene (12)
597	$C_{13}H_{22}$	Dihydro- α -santalene (12)	606	$C_{13}H_{22}$	Tetrahydro α -santalene (12)
598	$C_{13}H_{22}$	Tetrahydrocalamene (12) (structure not known)			and
599	$C_{13}H_{22}$	Tetrahydroeudesmene (12)			
		(same structure as Tetrahydroeudesmene, no 603)			(probably mixture)
600	$C_{13}H_{22}$	Tetrahydroguasene (12) (structure not known)	607	$C_{13}H_{22}$	Tetrahydro α -santalene (12)
601	$C_{13}H_{22}$	Tetrahydrozingerene (12)	608	"	Tetrahydro- α -santalene (12) (structures uncertain)

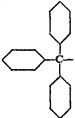
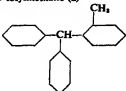
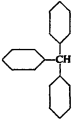
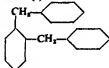
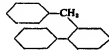
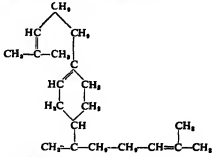
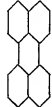
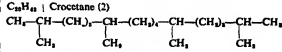
Ref no	Formula		Ref no	Formula	
609	C ₁₂ H ₂₂	Tetrahydro- β -santalene (12)	643	C ₁₂ H ₁₈	2,2'-Dimethylstilbene (2)
610	C ₁₂ H ₂₀	Hexahydro- α -curcumene (12)	653	C ₁₂ H ₁₈	1,2-Di- <i>o</i> -tolylethane (2)
611	"	Hexahydro- β -curcumene (12) (structures uncertain)			
612	C ₁₂ H ₂₀	Hexahydrobisabolene (12)	661	C ₁₇ H ₁₄	1-Benzylindaphthalene
613	"	Hexahydrozingiberene (12) (same structure)			
			668	C ₁₇ H ₁₂	Benzanthrene
614	C ₁₂ H ₂₀	Hexahydroelemene (12)	669	C ₁₂ H ₁₈	Truxene (structure uncertain)
			670	C ₁₂ H ₁₈	Chrysene (2)
616	C ₁₂ H ₂₆	Farnesane (12)	671	C ₁₂ H ₁₈	Triphenylene (10)
		$\text{CH}_2-\text{CH}(\text{CH}_2)-\text{CH}(\text{CH}_2)-\text{CH}(\text{CH}_2)-\text{CH}_2-\text{CH}_2$			
617	C ₁₂ H ₁₆	Pyrene (1)	674	C ₁₂ H ₁₄	Diphenylfulvene (2)
618	C ₁₂ H ₁₈	1,4-Diphenyl-1,3-butadiyne (2)	675	C ₁₂ H ₁₈	Retene (10)
621	C ₁₂ H ₁₈	Pseudophenanthrene (structure uncertain)	680	C ₁₂ H ₁₈	1,4-Di- <i>n</i> -butylnaphthalene (8)
622	C ₁₂ H ₁₆	Atronene			
624	C ₁₂ H ₁₄	1,2-Dimethylanthracene (2)			
632	C ₁₂ H ₁₄	1,3-Dimethylphenanthrene (2)			

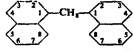
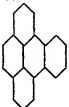
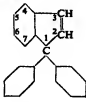
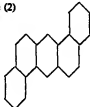
Ref no	Formula		Ref no	Formula	
682	$C_{19}H_{14}$	Fichtelite 	695	$C_{20}H_{14}$	1,1'-Dnaphthyl (2) 
687	$C_{19}H_{12}$	Triphenylmethyl 	700	$C_{20}H_{12}$	Diphenyl- <i>o</i> -tolylmethane (2) 
688	$C_{19}H_{12}$	Triphenylmethane 	703	$C_{20}H_{12}$	<i>o</i> -Dibenzylbenzene (2) 
689	$C_{19}H_{14}$	<i>o</i> -Benzylidiphenyl 	708	$C_{20}H_{12}$	α -Camphorene (2) (probable structure) 
692	$C_{20}H_{12}$	Perylene (10) 	710	$C_{20}H_{14}$	Crocetane (2) $CH_2-CH(CH_2)-CH(CH_2)-CH(CH_2)-CH(CH_2)-CH(CH_2)-CH(CH_2)-CH(CH_2)-CH(CH_2)-CH_2$ 
693	$C_{20}H_{12}$	1,2-Benzpyrene (2) 	711	$C_{20}H_{14}$	1,1'-Dnaphthylmethane (2) 
694	$C_{20}H_{12}$	4,5-Benzpyrene (2) 	714	$C_{21}H_{12}$	1,1-Diphenylindene (2) 
			722	$C_{20}H_{12}$	1,2,5,6-Dibenzanthracene (2) 

Ref no	Formula		Ref no	Formula	
723	$C_{28}H_{18}$	1,2,7,8-Dibenzanthracene (2)	743	$C_{27}H_{18}$	5,5'-Diacenaphthylmethane (2)
724	$C_{22}H_{14}$	Picene (1)	745	$C_{22}H_{14}$	Rubicene
725	$C_{22}H_{18}$	1,1(1,1'-Dinaphthyl)ethylene (2)			
729	$C_{22}H_{17}$	Diphenyl- β -naphthylmethyl (2)	746	$C_{20}H_{16}$	Difluorenylene (2)
730	$C_{22}H_{18}$	Diphenyl- β -naphthylmethane (2)	747	$C_{20}H_{16}$	Difluorenyl (2)
732	$C_{24}H_{16}$	Coronene (2)	748	$C_{28}H_{18}$	9,10-Diphenylphenanthrene
734	$C_{22}H_{18}$	2,2'-Diphenyldiphenyl (2)	756	$C_{31}H_{34}$	Cholestierene (2)
737	$C_{24}H_{18}$	7,7'-Diacenaphthyl (2)			

INDEX TO HYDROCARBONS

In the following index the preferred name is italicized

	Ref no		Ref no
<i>Acampylene</i> —Naphthylbenzene	C ₁₄ H ₁₈	<i>m,p</i> -Bitolyl— <i>m,p</i> -Diolyl	C ₁₄ H ₁₈
<i>Acampylene</i>	C ₁₄ H ₁₈	<i>p,p'</i> -Bitolyl— <i>p,p'</i> -Diolyl	C ₁₄ H ₁₈
<i>Acetylbenzene</i> —Ethylbenzene	C ₁₀ H ₁₂	<i>Bimyl</i> — <i>Bimolide</i>	C ₁₄ H ₁₈
<i>Acetylene</i> —Ethyne, Ethine	C ₂ H ₂	<i>Bisane</i> —4,8,12,16-Tetramethylcane	C ₁₄ H ₂₈
<i>Allane</i> —Propane	C ₃ H ₈	<i>Borylene</i> —1,1,7,7-Tetramethylcyclo-1,2,2-heptane 2	C ₁₄ H ₂₈
<i>Allo-octane</i> —2,6-Dimethyl-2,5-octanone or 2,6-Dimethyl-2,4,6-octanone	C ₁₀ H ₁₈	<i>β</i> -Butylene—Isopropylene	C ₁₄ H ₂₈
<i>Allylbenzene</i> —2-Propenylbenzene	C ₉ H ₁₀	<i>1,β</i> -Butadiene—Methylolene	C ₁₄ H ₂₈
<i>Allylene</i> —Propene	C ₃ H ₄	<i>1,β</i> -Butadiene—Divinyl Erythrene, Pyrolylene, Buvanyl, Vinylallylene, Butethylene	C ₁₄ H ₂₈
<i>Allylbenzene</i> —2-Propenylbenzene	C ₉ H ₁₀	<i>Butadiene</i> —Butadiene	C ₁₄ H ₂₈
<i>n</i> -Amylacetylene—1-Nepylene	C ₈ H ₁₀	<i>Butadiene</i> —Butadiene	C ₁₄ H ₂₈
<i>n</i> -Amylbenzene— <i>n</i> -Pentylbenzene 1 Phenylpentane	C ₁₀ H ₁₄	<i>n</i> -Butane—Butane Methylethylmethane	C ₁₄ H ₂₈
<i>sec</i> -Amylbenzene—1-Methylbutylbenzene	C ₁₀ H ₁₄	<i>Butane</i> — <i>n</i> -Butane	C ₁₄ H ₂₈
<i>tert</i> -Amylbenzene—2 Methyl 2 phenylbutane, (1,1-Dimethylpropyl)benzene	C ₁₀ H ₁₄	<i>1-Butene</i> —1-Butene	C ₁₄ H ₂₈
<i>Amylidimethylmethane</i> —2 Methyl-2-octane	C ₁₁ H ₁₆	<i>2-Butene</i> —2-Butene	C ₁₄ H ₂₈
<i>n</i> -Amylene—1-Pentene	C ₅ H ₈	<i>3-Butene 1-pyrene</i> —Vinylacetylene	C ₁₄ H ₂₈
<i>β</i> -Amylene—2-Pentene	C ₅ H ₈	<i>1-Butene</i> —1-Butyne	C ₁₄ H ₂₈
<i>β</i> -Amylene	C ₅ H ₈	<i>2-Butene</i> —2-Butyne	C ₁₄ H ₂₈
<i>β</i> -Amylene	C ₅ H ₈	<i>n</i> -Butylacetylene—1-Hexyne	C ₁₄ H ₂₈
<i>Anthracene</i>	C ₁₄ H ₁₀	<i>n</i> -Butylbenzene—1-Phenylbutane	C ₁₄ H ₂₈
<i>Anthracene-9,10-dihydro</i> —9,10-Dihydroanthracene	C ₁₄ H ₁₈	<i>sec</i> -Butylbenzene—2-Phenylbutane, (1-Methylpropyl)benzene	C ₁₄ H ₂₈
<i>Anthracene</i> —hexahydro— <i>n</i> -Hexahydroanthracene	C ₁₄ H ₁₈	<i>tert</i> -Butylbenzene—2 Methyl 2-phenylpropane	C ₁₄ H ₂₈
<i>Anthracene-9,10-dihydro</i> —9,10-Dihydroanthracene	C ₁₄ H ₁₈	<i>tert</i> -Butylbenzene—1-Phenylbutane	C ₁₄ H ₂₈
<i>Anthracene</i> —hexahydro— <i>n</i> -Hexahydroanthracene	C ₁₄ H ₁₈	<i>tert</i> -Butylbenzene (with <i>n</i> -1,1-Dimethylethyl)cyclohexane	C ₁₄ H ₂₈
<i>Anthracene</i>	C ₁₄ H ₁₀	<i>3-tert</i> -Butyl-1,3 dimethylbutane—1,3-Dimethyl-3-tert-butyl-1,3 dimethylbutane	C ₁₄ H ₂₈
<i>Anthracene</i>	C ₁₄ H ₁₀	<i>1-Butylene</i> — <i>n</i> -Butylene 1-Butene, Ethylbenzene	C ₁₄ H ₂₈
<i>Anthracene</i>	C ₁₄ H ₁₀	<i>2-Butylene</i> — <i>β</i> -Butylene 2-Butene 1,2-Dimethylethylene, <i>n</i> -Butylene	C ₁₄ H ₂₈
<i>Anthracene</i>	C ₁₄ H ₁₀	<i>3-Butylene</i> — <i>γ</i> -Butylene pseudo-Butylene	C ₁₄ H ₂₈
<i>Anthracene</i>	C ₁₄ H ₁₀	<i>4-Butylene</i> —1-Butylene	C ₁₄ H ₂₈
<i>Anthracene</i>	C ₁₄ H ₁₀	<i>5-Butylene</i> —2-Butylene	C ₁₄ H ₂₈
<i>Anthracene</i>	C ₁₄ H ₁₀	<i>6-Butylene</i> —3-Butylene	C ₁₄ H ₂₈
<i>Anthracene</i>	C ₁₄ H ₁₀	<i>7-Butylene</i> —Isobutylene	C ₁₄ H ₂₈
<i>Anthracene</i>	C ₁₄ H ₁₀	<i>8-Butylene</i> —Isobutylene	C ₁₄ H ₂₈
<i>Anthracene</i>	C ₁₄ H ₁₀	<i>9-Butylene</i> —Isobutylene	C ₁₄ H ₂₈
<i>Anthracene</i>	C ₁₄ H ₁₀	<i>10-Butylene</i> —Isobutylene	C ₁₄ H ₂₈
<i>Anthracene</i>	C ₁₄ H ₁₀	<i>11-Butylene</i> —Isobutylene	C ₁₄ H ₂₈
<i>Anthracene</i>	C ₁₄ H ₁₀	<i>12-Butylene</i> —Isobutylene	C ₁₄ H ₂₈
<i>Anthracene</i>	C ₁₄ H ₁₀	<i>13-Butylene</i> —Isobutylene	C ₁₄ H ₂₈
<i>Anthracene</i>	C ₁₄ H ₁₀	<i>14-Butylene</i> —Isobutylene	C ₁₄ H ₂₈
<i>Anthracene</i>	C ₁₄ H ₁₀	<i>15-Butylene</i> —Isobutylene	C ₁₄ H ₂₈
<i>Anthracene</i>	C ₁₄ H ₁₀	<i>16-Butylene</i> —Isobutylene	C ₁₄ H ₂₈
<i>Anthracene</i>	C ₁₄ H ₁₀	<i>17-Butylene</i> —Isobutylene	C ₁₄ H ₂₈
<i>Anthracene</i>	C ₁₄ H ₁₀	<i>18-Butylene</i> —Isobutylene	C ₁₄ H ₂₈
<i>Anthracene</i>	C ₁₄ H ₁₀	<i>19-Butylene</i> —Isobutylene	C ₁₄ H ₂₈
<i>Anthracene</i>	C ₁₄ H ₁₀	<i>20-Butylene</i> —Isobutylene	C ₁₄ H ₂₈
<i>Anthracene</i>	C ₁₄ H ₁₀	<i>21-Butylene</i> —Isobutylene	C ₁₄ H ₂₈
<i>Anthracene</i>	C ₁₄ H ₁₀	<i>22-Butylene</i> —Isobutylene	C ₁₄ H ₂₈
<i>Anthracene</i>	C ₁₄ H ₁₀	<i>23-Butylene</i> —Isobutylene	C ₁₄ H ₂₈
<i>Anthracene</i>	C ₁₄ H ₁₀	<i>24-Butylene</i> —Isobutylene	C ₁₄ H ₂₈
<i>Anthracene</i>	C ₁₄ H ₁₀	<i>25-Butylene</i> —Isobutylene	C ₁₄ H ₂₈
<i>Anthracene</i>	C ₁₄ H ₁₀	<i>26-Butylene</i> —Isobutylene	C ₁₄ H ₂₈
<i>Anthracene</i>	C ₁₄ H ₁₀	<i>27-Butylene</i> —Isobutylene	C ₁₄ H ₂₈
<i>Anthracene</i>	C ₁₄ H ₁₀	<i>28-Butylene</i> —Isobutylene	C ₁₄ H ₂₈
<i>Anthracene</i>	C ₁₄ H ₁₀	<i>29-Butylene</i> —Isobutylene	C ₁₄ H ₂₈
<i>Anthracene</i>	C ₁₄ H ₁₀	<i>30-Butylene</i> —Isobutylene	C ₁₄ H ₂₈
<i>Anthracene</i>	C ₁₄ H ₁₀	<i>31-Butylene</i> —Isobutylene	C ₁₄ H ₂₈
<i>Anthracene</i>	C ₁₄ H ₁₀	<i>32-Butylene</i> —Isobutylene	C ₁₄ H ₂₈
<i>Anthracene</i>	C ₁₄ H ₁₀	<i>33-Butylene</i> —Isobutylene	C ₁₄ H ₂₈
<i>Anthracene</i>	C ₁₄ H ₁₀	<i>34-Butylene</i> —Isobutylene	C ₁₄ H ₂₈
<i>Anthracene</i>	C ₁₄ H ₁₀	<i>35-Butylene</i> —Isobutylene	C ₁₄ H ₂₈
<i>Anthracene</i>	C ₁₄ H ₁₀	<i>36-Butylene</i> —Isobutylene	C ₁₄ H ₂₈
<i>Anthracene</i>	C ₁₄ H ₁₀	<i>37-Butylene</i> —Isobutylene	C ₁₄ H ₂₈
<i>Anthracene</i>	C ₁₄ H ₁₀	<i>38-Butylene</i> —Isobutylene	C ₁₄ H ₂₈
<i>Anthracene</i>	C ₁₄ H ₁₀	<i>39-Butylene</i> —Isobutylene	C ₁₄ H ₂₈
<i>Anthracene</i>	C ₁₄ H ₁₀	<i>40-Butylene</i> —Isobutylene	C ₁₄ H ₂₈
<i>Anthracene</i>	C ₁₄ H ₁₀	<i>41-Butylene</i> —Isobutylene	C ₁₄ H ₂₈
<i>Anthracene</i>	C ₁₄ H ₁₀	<i>42-Butylene</i> —Isobutylene	C ₁₄ H ₂₈
<i>Anthracene</i>	C ₁₄ H ₁₀	<i>43-Butylene</i> —Isobutylene	C ₁₄ H ₂₈
<i>Anthracene</i>	C ₁₄ H ₁₀	<i>44-Butylene</i> —Isobutylene	C ₁₄ H ₂₈
<i>Anthracene</i>	C ₁₄ H ₁₀	<i>45-Butylene</i> —Isobutylene	C ₁₄ H ₂₈
<i>Anthracene</i>	C ₁₄ H ₁₀	<i>46-Butylene</i> —Isobutylene	C ₁₄ H ₂₈
<i>Anthracene</i>	C ₁₄ H ₁₀	<i>47-Butylene</i> —Isobutylene	C ₁₄ H ₂₈
<i>Anthracene</i>	C ₁₄ H ₁₀	<i>48-Butylene</i> —Isobutylene	C ₁₄ H ₂₈
<i>Anthracene</i>	C ₁₄ H ₁₀	<i>49-Butylene</i> —Isobutylene	C ₁₄ H ₂₈
<i>Anthracene</i>	C ₁₄ H ₁₀	<i>50-Butylene</i> —Isobutylene	C ₁₄ H ₂₈
<i>Anthracene</i>	C ₁₄ H ₁₀	<i>51-Butylene</i> —Isobutylene	C ₁₄ H ₂₈
<i>Anthracene</i>	C ₁₄ H ₁₀	<i>52-Butylene</i> —Isobutylene	C ₁₄ H ₂₈
<i>Anthracene</i>	C ₁₄ H ₁₀	<i>53-Butylene</i> —Isobutylene	C ₁₄ H ₂₈
<i>Anthracene</i>	C ₁₄ H ₁₀	<i>54-Butylene</i> —Isobutylene	C ₁₄ H ₂₈
<i>Anthracene</i>	C ₁₄ H ₁₀	<i>55-Butylene</i> —Isobutylene	C ₁₄ H ₂₈
<i>Anthracene</i>	C ₁₄ H ₁₀	<i>56-Butylene</i> —Isobutylene	C ₁₄ H ₂₈
<i>Anthracene</i>	C ₁₄ H ₁₀	<i>57-Butylene</i> —Isobutylene	C ₁₄ H ₂₈
<i>Anthracene</i>	C ₁₄ H ₁₀	<i>58-Butylene</i> —Isobutylene	C ₁₄ H ₂₈
<i>Anthracene</i>	C ₁₄ H ₁₀	<i>59-Butylene</i> —Isobutylene	C ₁₄ H ₂₈
<i>Anthracene</i>	C ₁₄ H ₁₀	<i>60-Butylene</i> —Isobutylene	C ₁₄ H ₂₈
<i>Anthracene</i>	C ₁₄ H ₁₀	<i>61-Butylene</i> —Isobutylene	C ₁₄ H ₂₈
<i>Anthracene</i>	C ₁₄ H ₁₀	<i>62-Butylene</i> —Isobutylene	C ₁₄ H ₂₈
<i>Anthracene</i>	C ₁₄ H ₁₀	<i>63-Butylene</i> —Isobutylene	C ₁₄ H ₂₈
<i>Anthracene</i>	C ₁₄ H ₁₀	<i>64-Butylene</i> —Isobutylene	C ₁₄ H ₂₈
<i>Anthracene</i>	C ₁₄ H ₁₀	<i>65-Butylene</i> —Isobutylene	C ₁₄ H ₂₈
<i>Anthracene</i>	C ₁₄ H ₁₀	<i>66-Butylene</i> —Isobutylene	C ₁₄ H ₂₈
<i>Anthracene</i>	C ₁₄ H ₁₀	<i>67-Butylene</i> —Isobutylene	C ₁₄ H ₂₈
<i>Anthracene</i>	C ₁₄ H ₁₀	<i>68-Butylene</i> —Isobutylene	C ₁₄ H ₂₈
<i>Anthracene</i>	C ₁₄ H ₁₀	<i>69-Butylene</i> —Isobutylene	C ₁₄ H ₂₈
<i>Anthracene</i>	C ₁₄ H ₁₀	<i>70-Butylene</i> —Isobutylene	C ₁₄ H ₂₈
<i>Anthracene</i>	C ₁₄ H ₁₀	<i>71-Butylene</i> —Isobutylene	C ₁₄ H ₂₈
<i>Anthracene</i>	C ₁₄ H ₁₀	<i>72-Butylene</i> —Isobutylene	C ₁₄ H ₂₈
<i>Anthracene</i>	C ₁₄ H ₁₀	<i>73-Butylene</i> —Isobutylene	C ₁₄ H ₂₈
<i>Anthracene</i>	C ₁₄ H ₁₀	<i>74-Butylene</i> —Isobutylene	C ₁₄ H ₂₈
<i>Anthracene</i>	C ₁₄ H ₁₀	<i>75-Butylene</i> —Isobutylene	C ₁₄ H ₂₈
<i>Anthracene</i>	C ₁₄ H ₁₀	<i>76-Butylene</i> —Isobutylene	C ₁₄ H ₂₈
<i>Anthracene</i>	C ₁₄ H ₁₀	<i>77-Butylene</i> —Isobutylene	C ₁₄ H ₂₈
<i>Anthracene</i>	C ₁₄ H ₁₀	<i>78-Butylene</i> —Isobutylene	C ₁₄ H ₂₈
<i>Anthracene</i>	C ₁₄ H ₁₀	<i>79-Butylene</i> —Isobutylene	C ₁₄ H ₂₈
<i>Anthracene</i>	C ₁₄ H ₁₀	<i>80-Butylene</i> —Isobutylene	C ₁₄ H ₂₈
<i>Anthracene</i>	C ₁₄ H ₁₀	<i>81-Butylene</i> —Isobutylene	C ₁₄ H ₂₈
<i>Anthracene</i>	C ₁₄ H ₁₀	<i>82-Butylene</i> —Isobutylene	C ₁₄ H ₂₈
<i>Anthracene</i>	C ₁₄ H ₁₀	<i>83-Butylene</i> —Isobutylene	C ₁₄ H ₂₈
<i>Anthracene</i>	C ₁₄ H ₁₀	<i>84-Butylene</i> —Isobutylene	C ₁₄ H ₂₈
<i>Anthracene</i>	C ₁₄ H ₁₀	<i>85-Butylene</i> —Isobutylene	C ₁₄ H ₂₈
<i>Anthracene</i>	C ₁₄ H ₁₀	<i>86-Butylene</i> —Isobutylene	C ₁₄ H ₂₈
<i>Anthracene</i>	C ₁₄ H ₁₀	<i>87-Butylene</i> —Isobutylene	C ₁₄ H ₂₈
<i>Anthracene</i>	C ₁₄ H ₁₀	<i>88-Butylene</i> —Isobutylene	C ₁₄ H ₂₈
<i>Anthracene</i>	C ₁₄ H ₁₀	<i>89-Butylene</i> —Isobutylene	C ₁₄ H ₂₈
<i>Anthracene</i>	C ₁₄ H ₁₀	<i>90-Butylene</i> —Isobutylene	C ₁₄ H ₂₈
<i>Anthracene</i>	C ₁₄ H ₁₀	<i>91-Butylene</i> —Isobutylene	C ₁₄ H ₂₈
<i>Anthracene</i>	C ₁₄ H ₁₀	<i>92-Butylene</i> —Isobutylene	C ₁₄ H ₂₈
<i>Anthracene</i>	C ₁₄ H ₁₀	<i>93-Butylene</i> —Isobutylene	C ₁₄ H ₂₈
<i>Anthracene</i>	C ₁₄ H ₁₀	<i>94-Butylene</i> —Isobutylene	C ₁₄ H ₂₈
<i>Anthracene</i>	C ₁₄ H ₁₀	<i>95-Butylene</i> —Isobutylene	C ₁₄ H ₂₈
<i>Anthracene</i>	C ₁₄ H ₁₀	<i>96-Butylene</i> —Isobutylene	C ₁₄ H ₂₈
<i>Anthracene</i>	C ₁₄ H ₁₀	<i>97-Butylene</i> —Isobutylene	C ₁₄ H ₂₈
<i>Anthracene</i>	C ₁₄ H ₁₀	<i>98-Butylene</i> —Isobutylene	C ₁₄ H ₂₈
<i>Anthracene</i>	C ₁₄ H ₁₀	<i>99-Butylene</i> —Isobutylene	C ₁₄ H ₂₈
<i>Anthracene</i>	C ₁₄ H ₁₀	<i>100-Butylene</i> —Isobutylene	C ₁₄ H ₂₈
<i>Anthracene</i>	C ₁₄ H ₁₀	<i>101-Butylene</i> —Isobutylene	C ₁₄ H ₂₈
<i>Anthracene</i>	C ₁₄ H ₁₀	<i>102-Butylene</i> —Isobutylene	C ₁₄ H ₂₈
<i>Anthracene</i>	C ₁₄ H ₁₀	<i>103-Butylene</i> —Isobutylene	C ₁₄ H ₂₈
<i>Anthracene</i>	C ₁₄ H ₁₀	<i>104-Butylene</i> —Isobutylene	C ₁₄ H ₂₈
<i>Anthracene</i>	C ₁₄ H ₁₀	<i>105-Butylene</i> —Isobutylene	C ₁₄ H ₂₈
<i>Anthracene</i>	C ₁₄ H ₁₀	<i>106-Butylene</i> —Isobutylene	C ₁₄ H ₂₈
<i>Anthracene</i>	C ₁₄ H ₁₀	<i>107-Butylene</i> —Isobutylene	C ₁₄ H ₂₈
<i>Anthracene</i>	C ₁₄ H ₁₀	<i>108-Butylene</i> —Isobutylene	C ₁₄ H ₂₈
<i>Anthracene</i>	C ₁₄ H ₁₀	<i>109-Butylene</i> —Isobutylene	C ₁₄ H ₂₈
<i>Anthracene</i>	C ₁₄ H ₁₀	<i>110-Butylene</i> —Isobutylene	C ₁₄ H ₂₈
<i>Anthracene</i>	C ₁₄ H ₁₀	<i>111-Butylene</i> —Isobutylene	C ₁₄ H ₂₈
<i>Anthracene</i>	C ₁₄ H ₁₀	<i>112-Butylene</i> —Isobutylene	C ₁₄ H ₂₈
<i>Anthracene</i>	C ₁₄ H ₁₀	<i>113-Butylene</i> —Isobutylene	C ₁₄ H ₂₈
<i>Anthracene</i>	C ₁₄ H ₁₀	<i>114-Butylene</i> —Isobutylene	C ₁₄ H ₂₈
<i>Anthracene</i>	C ₁₄ H ₁₀	<i>115-Butylene</i> —Isobutylene	C ₁₄ H ₂₈
<i>Anthracene</i>	C ₁₄ H ₁₀	<i>116-Butylene</i> —Isobutylene	C ₁₄ H ₂₈
<i>Anthracene</i>	C ₁₄ H ₁₀	<i>117-Butylene</i> —Isobutylene	C ₁₄ H ₂₈
<i>Anthracene</i>	C ₁₄ H ₁₀	<i>118-Butylene</i> —Isobutylene	C ₁₄ H<

	Ref no		Re no
Dihydro-norbornene—Dihydroindolene, Linaloolene, 2,6-Dimethyl-2-octadiene	C ₁₀ H ₁₆	392	
1,2-Dihydro-naphthalene—2,3-Dihydro-naphthalene, Naphthalene-1,2-dihydro	C ₁₀ H ₁₀	299	
1,4-Dihydro-naphthalene—2,3-Dihydro-naphthalene, Naphthalene-1,4-dihydro	C ₁₀ H ₁₀	300	
Δ ¹ -Dihydro-naphthalene—1,2,3-Dihydro-naphthalene	C ₁₀ H ₁₀	299	
Δ ² -Dihydro-naphthalene—1,2,3-Dihydro-naphthalene	C ₁₀ H ₁₀	300	
Dihydroindolene—Dihydro-cyclopentadiene	C ₁₀ H ₁₆	392	
9,10-Dihydro-phenanthrene—Phenanthrene-9,10-dihydro	C ₁₄ H ₁₈	300	
Dihydroquinoline—4-Thiophene	C ₁₀ H ₁₀	287	
Dihydro-oxindole—Dihydro-oxindole	C ₁₀ H ₁₀	597	
Dihydro-selenene—Dihydro-selenene	C ₁₀ H ₁₀	594	
Dihydro-terpene—1-Methyl-4-isopropylidene-cyclohexane	C ₁₀ H ₁₈	380	
1,2-Dihydro-terpene	C ₁₀ H ₁₈	95	
Dihydro-terpene—1,3-Cyclohexadiene	C ₁₀ H ₁₈	94	
Δ ¹ -Dihydro-o-xylene—2,5-Dimethyl-1,3-cyclohexadiene	C ₁₀ H ₁₆	165	
Δ ² -Dihydro-m-xylene—1,3-Dimethyl-1,3-cyclohexadiene	C ₁₀ H ₁₆	162	
Δ ³ -Dihydro-p-xylene—1,4-Dimethyl-1,3-cyclohexadiene	C ₁₀ H ₁₆	167	
Δ ⁴ -Dihydro-o-xylene—1,5-Dimethyl-1,3-cyclohexadiene	C ₁₀ H ₁₆	164	
Δ ⁵ -Dihydro-p-xylene—1,6-Dimethyl-1,3-cyclohexadiene	C ₁₀ H ₁₆	163	
Δ ⁶ -Dihydro-o-xylene—2,5-Dimethyl-1,3-cyclohexadiene	C ₁₀ H ₁₆	166	
Dihydro-terpene	C ₁₀ H ₁₈	596	
Diisocyanate—2,7-Dimethyl-5-azabicyclo[2.2.1]heptane	C ₁₀ H ₁₆	415	
Diisobutylene—2,5-Dimethyl-2,5-hexadiene	C ₁₀ H ₁₈	318	
Diisobutylene—2,5-Dimethyl-2,5-hexadiene	C ₁₀ H ₁₈	223	
Diisobutylene—2,4,6-Trimethyl-1,6-heptadiene	C ₁₀ H ₁₈	214	
Diisobutylene—2,5-Dimethyl-2,5-hexadiene	C ₁₀ H ₁₈	215	
1,4-Diisobutylphthalate	C ₁₀ H ₁₈	680	
Diisocyanate—1,5-Dimethyl-4,6-hexadiene	C ₁₀ H ₁₈	190	
Diisocyanate—1,5-Dimethyl-2,4-hexadiene	C ₁₀ H ₁₈	190	
Diisoprene—Limonene	C ₁₀ H ₁₆	348	
Diisopropyl—2,3-Dimethyl-1,3-butadiene	C ₁₀ H ₁₈	66	
1,6-Diisopropyl-1,4-cyclohexadiene	C ₁₀ H ₁₈	467	
Diisopropyl—2,5-Dimethyl-2,5-hexadiene	C ₁₀ H ₁₈	91	
Diisopropylidene-cyclohexane	C ₁₀ H ₁₈	401	
Diisopropylidene-cyclohexane	C ₁₀ H ₁₈	151	
Diisopropylmethane—2,4-Dimethyl-pentane	C ₁₀ H ₁₈	7	
Dimethyl—Ethane	C ₁₀ H ₁₈	19	
Dimethylacetone—2-Butyne	C ₁₀ H ₁₈	33	
Dimethylallene—2,3-Pentadiene	C ₁₀ H ₁₆	33	
Dimethylallene—3-Methyl-1,3-butadiene	C ₁₀ H ₁₆	34	
Dimethylaminomethane—3-Methylthiophene	C ₁₀ H ₁₆	216	
1,5-Dimethylanthracene	C ₁₄ H ₁₈	624	
1,6-Dimethylanthracene	C ₁₄ H ₁₈	625	
2,5-Dimethylanthracene	C ₁₄ H ₁₈	626	
2,6-Dimethylanthracene	C ₁₄ H ₁₈	627	
2,7-Dimethylanthracene	C ₁₄ H ₁₈	628	
2,8-Dimethylanthracene	C ₁₄ H ₁₈	629	
2,9-Dimethylanthracene	C ₁₄ H ₁₈	630	
9,10-Dimethylanthracene—10-Dimethylanthracene	C ₁₄ H ₁₈	631	
10-Dimethylanthracene	C ₁₄ H ₁₈	631	
1,2-Dimethylbenzene—o-Xylene	C ₁₀ H ₁₆	157	
1,3-Dimethylbenzene—m-Xylene	C ₁₀ H ₁₆	158	
1,4-Dimethylbenzene—p-Xylene	C ₁₀ H ₁₆	159	
6,6-Dimethyl-1,1,3-bicyclopentane—Nopane	C ₁₀ H ₁₆	255	
2,5-Dimethylbutane—2,4-Hexadiene	C ₁₀ H ₁₈	63	
2,5-Dimethyl-1,3-butadiene—Di-isopropene, 2,3-Dimethyl-erythrene, Di-isopropyl, 1,5-Dimethylbutadiene	C ₁₀ H ₁₆	66	
1,5-Dimethylbutadiene—2,5-Dimethyl-1,3-butadiene	C ₁₀ H ₁₆	66	
2,5-Dimethylbutane—2-Ethylbutane, Neobutane, Trimethylsilylacetone, tert-Butylbenzene	C ₁₀ H ₁₈	90	
2,3-Dimethylbutane—Di-isopropyl, silyl-Tetramethylbutane, Di-isopropyl, silyl-Tetramethylbutane	C ₁₀ H ₁₈	91	
2,3-Dimethyl-1-butene—R,y-Dimethyl-butene, 1-Methyl-1-isopropylthylene	C ₁₀ H ₁₈	84	
2,3-Dimethyl-1-butene—R,y-Dimethyl-butene, Tetramethylthylene	C ₁₀ H ₁₈	86	
3,3-Dimethyl-1-butene—γ-Dimethyl-butene, tert-Butylthylene, pseudo-Butylthylene	C ₁₀ H ₁₈	85	
γ-Dimethyl-butene—γ-Dimethyl-1-butene	C ₁₀ H ₁₈	84	
δ-Dimethyl-2-butene—2,3-Dimethyl-2-butene	C ₁₀ H ₁₈	86	
γ-Dimethyl-2-butene—2,3-Dimethyl-1-butene	C ₁₀ H ₁₈	85	
3,3-Dimethyl-1-ene—Diisopropene—2-eryl-Butyl-m-xylene, 5-tert-Butyl-1,3-dimethylbenzene	C ₁₀ H ₁₈	469	
(1,1-Dimethylbutyl)cyclohexane—2-Cyclohexyl-2-methylthiophene	C ₁₀ H ₁₈	474	
4,4-Dimethylcyclohexane—1,2-Dimethyl-3-isopropylbenzene, 4-Isopropyl-4-cyclohexane	C ₁₀ H ₁₈	437	
1,1-Dimethyl-2-cyclohexanone—3,5-Dimethyl-1,3-cyclohexadiene	C ₁₀ H ₁₆	168	
1,2-Dimethyl-2-cyclohexanone—3,5-Dimethyl-1,3-cyclohexadiene	C ₁₀ H ₁₆	165	
1,3-Dimethyl-3-cyclohexanone—Δ ¹ -Dihydro-o-xylene	C ₁₀ H ₁₆	162	
1,3-Dimethyl-1,5-cyclohexadiene—2,6-Dimethyl-1,3-cyclohexadiene	C ₁₀ H ₁₆	167	
1,3-Dimethyl-1,5-cyclohexadiene—1,5-Dimethyl-1,3-cyclohexadiene	C ₁₀ H ₁₆	164	
1,6-Dimethyl-1,3-cyclohexadiene—Δ ¹ -Dihydro-o-xylene	C ₁₀ H ₁₆	163	
1,6-Dimethyl-1,5-cyclohexadiene—2,5-Dimethyl-1,3-cyclohexadiene	C ₁₀ H ₁₆	166	
1,5-Dimethyl-1,5-cyclohexadiene—Δ ¹ -Dihydro-m-xylene, 1,3-Dimethyl-3-cyclohexadiene	C ₁₀ H ₁₆	164	
1,3-Dimethyl-3-cyclohexadiene—Δ ¹ -Dihydro-o-xylene, 1,4-Dimethyl-1,5-cyclohexadiene, 3,6-Dimethyl-1,3-cyclohexadiene	C ₁₀ H ₁₆	166	
1,3-Dimethyl-3-cyclohexadiene—Δ ¹ -Dihydro-m-xylene, 1,3-Dimethyl-3-cyclohexadiene	C ₁₀ H ₁₆	164	
2,5-Dimethyl-3-cyclohexadiene—Δ ¹ -Dihydro-o-xylene, 1,4-Dimethyl-1,5-cyclohexadiene, 3,6-Dimethyl-1,3-cyclohexadiene	C ₁₀ H ₁₆	166	
3,5-Dimethyl-1,3-cyclohexadiene—2,6-Dimethyl-1,3-cyclohexadiene	C ₁₀ H ₁₆	167	
3,5-Dimethyl-1,3-cyclohexadiene—2,6-Dimethyl-1,3-cyclohexadiene	C ₁₀ H ₁₆	167	
3,5-Dimethyl-1,3-cyclohexadiene—2,6-Dimethyl-1,3-cyclohexadiene	C ₁₀ H ₁₆	167	
3,6-Dimethyl-1,3-cyclohexadiene—2,5-Dimethyl-1,3-cyclohexadiene	C ₁₀ H ₁₆	166	
5,5-Dimethyl-1,3-cyclohexadiene—1,1-Dimethyl-2-cyclohexanone	C ₁₀ H ₁₆	168	
1,1-Dimethylcyclohexane—Dimethylcyclohexane, Hexahydro-o-xylene	C ₁₀ H ₁₈	193	
1,3-Dimethylcyclohexane—Dimethylcyclohexane, Hexahydro-o-xylene	C ₁₀ H ₁₈	196	
1,4-Dimethylcyclohexane—Dimethylcyclohexane, Hexahydro-o-xylene	C ₁₀ H ₁₈	197	
o-Dimethylcyclohexane—1,3-Dimethylcyclohexane	C ₁₀ H ₁₈	198	
m-Dimethylcyclohexane—1,3-Dimethylcyclohexane	C ₁₀ H ₁₈	198	
p-Dimethylcyclohexane—1,4-Dimethyl-1-cyclohexene	C ₁₀ H ₁₈	178	
1,1-Dimethyl-1-cyclohexene—1,2-Dimethyl-1-cyclohexene	C ₁₀ H ₁₆	172	
1,2-Dimethyl-1-cyclohexene—1,3-Dimethyl-1-cyclohexene	C ₁₀ H ₁₆	176	
1,3-Dimethyl-1-cyclohexene—Δ ¹ -Tetrahydro-m-xylene	C ₁₀ H ₁₆	173	
1,3-Dimethyl-1-cyclohexene—1,5-Dimethyl-1-cyclohexene	C ₁₀ H ₁₆	175	
1,4-Dimethyl-1-cyclohexene—3,5-Dimethyl-1-cyclohexene	C ₁₀ H ₁₆	177	
Δ ¹ -Tetrahydro-p-xylene	C ₁₀ H ₁₆	174	
1,5-Dimethyl-1-cyclohexene—1,3-Dimethyl-1-cyclohexene, 1,2-Dimethyl-1-cyclohexene, Δ ¹ -Tetrahydro-m-xylene	C ₁₀ H ₁₆	175	
1-cyclohexane, Δ ¹ -Tetrahydro-m-xylene	C ₁₀ H ₁₈	175	
2,4-Dimethyl-1-cyclohexene—1,3-Dimethyl-1-cyclohexene	C ₁₀ H ₁₆	175	
3,4-Dimethyl-1-cyclohexene—1,3-Dimethyl-1-cyclohexene	C ₁₀ H ₁₆	176	
3,5-Dimethyl-1-cyclohexene—1,3-Dimethyl-1-cyclohexene, 1,2,3,4-Tetrahydro-m-xylene	C ₁₀ H ₁₆	177	
4,4-Dimethyl-1-cyclohexene—1,1-Dimethyl-3-cyclohexene, 1,1-Dimethyl-Δ ¹ -cyclohexane	C ₁₀ H ₁₆	178	
1,1-Dimethyl-Δ ¹ -cyclohexane—1,1-Dimethyl-1-cyclohexene	C ₁₀ H ₁₆	178	
1,2-Dimethyl-Δ ¹ -cyclohexane—1,2-Dimethyl-1-cyclohexene	C ₁₀ H ₁₆	172	
1,3-Dimethyl-Δ ¹ -cyclohexane—1,3-Dimethyl-1-cyclohexene	C ₁₀ H ₁₆	176	
1,4-Dimethyl-Δ ¹ -cyclohexane—1,4-Dimethyl-1-cyclohexene	C ₁₀ H ₁₆	173	
1,5-Dimethyl-Δ ¹ -cyclohexane—1,5-Dimethyl-1-cyclohexene	C ₁₀ H ₁₆	175	
1,6-Dimethyl-Δ ¹ -cyclohexane—1,6-Dimethyl-1-cyclohexene	C ₁₀ H ₁₆	174	
1,1-Dimethyl-Δ ¹ -cyclohexane—1,4-Dimethyl-1-cyclohexene	C ₁₀ H ₁₆	178	
1,2-Dimethyl-Δ ¹ -cyclohexane—1,3-Dimethyl-1-cyclohexene	C ₁₀ H ₁₆	172	
1,3-Dimethyl-Δ ¹ -cyclohexane—1,4-Dimethyl-1-cyclohexene	C ₁₀ H ₁₆	176	
1,4-Dimethyl-Δ ¹ -cyclohexane—1,5-Dimethyl-1-cyclohexene	C ₁₀ H ₁₆	173	
1,5-Dimethyl-Δ ¹ -cyclohexane—1,6-Dimethyl-1-cyclohexene	C ₁₀ H ₁₆	175	
1,6-Dimethyl-Δ ¹ -cyclohexane—1,1-Dimethyl-1-cyclohexene	C ₁₀ H ₁₆	178	
1,1-Dimethyl-Δ ¹ -cyclohexane—1,2-Dimethyl-1-cyclohexene	C ₁₀ H ₁₆	172	
1,2-Dimethyl-Δ ¹ -cyclohexane—1,3-Dimethyl-1-cyclohexene	C ₁₀ H ₁₆	176	
1,3-Dimethyl-Δ ¹ -cyclohexane—1,4-Dimethyl-1-cyclohexene	C ₁₀ H ₁₆	173	
1,4-Dimethyl-Δ ¹ -cyclohexane—1,5-Dimethyl-1-cyclohexene	C ₁₀ H ₁₆	175	
1,5-Dimethyl-Δ ¹ -cyclohexane—1,6-Dimethyl-1-cyclohexene	C ₁₀ H ₁₆	174	
1,6-Dimethyl-Δ ¹ -cyclohexane—1,1-Dimethyl-1-cyclohexene	C ₁₀ H ₁₆	178	
1,1-Dimethyl-Δ ¹ -cyclohexane—1,2-Dimethyl-1-cyclohexene	C ₁₀ H ₁₆	172	
1,2-Dimethyl-Δ ¹ -cyclohexane—1,3-Dimethyl-1-cyclohexene	C ₁₀ H ₁₆	176	
1,3-Dimethyl-Δ ¹ -cyclohexane—1,4-Dimethyl-1-cyclohexene	C ₁₀ H ₁₆	173	
1,4-Dimethyl-Δ ¹ -cyclohexane—1,5-Dimethyl-1-cyclohexene	C ₁₀ H ₁₆	175	
1,5-Dimethyl-Δ ¹ -cyclohexane—1,6-Dimethyl-1-cyclohexene	C ₁₀ H ₁₆	174	
1,6-Dimethyl-Δ ¹ -cyclohexane—1,1-Dimethyl-1-cyclohexene	C ₁₀ H ₁₆	178	
1,1-Dimethyl-Δ ¹ -cyclohexane—1,2-Dimethyl-1-cyclohexene	C ₁₀ H ₁₆	172	
1,2-Dimethyl-Δ ¹ -cyclohexane—1,3-Dimethyl-1-cyclohexene	C ₁₀ H ₁₆	176	
1,3-Dimethyl-Δ ¹ -cyclohexane—1,4-Dimethyl-1-cyclohexene	C ₁₀ H ₁₆	173	
1,4-Dimethyl-Δ ¹ -cyclohexane—1,5-Dimethyl-1-cyclohexene	C ₁₀ H ₁₆	175	
1,5-Dimethyl-Δ ¹ -cyclohexane—1,6-Dimethyl-1-cyclohexene	C ₁₀ H ₁₆	174	
1,6-Dimethyl-Δ ¹ -cyclohexane—1,1-Dimethyl-1-cyclohexene	C ₁₀ H ₁₆	178	
1,1-Dimethyl-Δ ¹ -cyclohexane—1,2-Dimethyl-1-cyclohexene	C ₁₀ H ₁₆	172	
1,2-Dimethyl-Δ ¹ -cyclohexane—1,3-Dimethyl-1-cyclohexene	C ₁₀ H ₁₆	176	
1,3-Dimethyl-Δ ¹ -cyclohexane—1,4-Dimethyl-1-cyclohexene	C ₁₀ H ₁₆	173	
1,4-Dimethyl-Δ ¹ -cyclohexane—1,5-Dimethyl-1-cyclohexene	C ₁₀ H ₁₆	175	
1,5-Dimethyl-Δ ¹ -cyclohexane—1,6-Dimethyl-1-cyclohexene	C ₁₀ H ₁₆	174	
1,6-Dimethyl-Δ ¹ -cyclohexane—1,1-Dimethyl-1-cyclohexene	C ₁₀ H ₁₆	178	
1,1-Dimethyl-Δ ¹ -cyclohexane—1,2-Dimethyl-1-cyclohexene	C ₁₀ H ₁₆	172	
1,2-Dimethyl-Δ ¹ -cyclohexane—1,3-Dimethyl-1-cyclohexene	C ₁₀ H ₁₆	176	
1,3-Dimethyl-Δ ¹ -cyclohexane—1,4-Dimethyl-1-cyclohexene	C ₁₀ H ₁₆	173	
1,4-Dimethyl-Δ ¹ -cyclohexane—1,5-Dimethyl-1-cyclohexene	C ₁₀ H ₁₆	175	
1,5-Dimethyl-Δ ¹ -cyclohexane—1,6-Dimethyl-1-cyclohexene	C ₁₀ H ₁₆	174	
1,6-Dimethyl-Δ ¹ -cyclohexane—1,1-Dimethyl-1-cyclohexene	C ₁₀ H ₁₆	178	
1,1-Dimethyl-Δ ¹ -cyclohexane—1,2-Dimethyl-1-cyclohexene	C ₁₀ H ₁₆	172	
1,2-Dimethyl-Δ ¹ -cyclohexane—1,3-Dimethyl-1-cyclohexene	C ₁₀ H ₁₆	176	
1,3-Dimethyl-Δ ¹ -cyclohexane—1,4-Dimethyl-1-cyclohexene	C ₁₀ H ₁₆	173	
1,4-Dimethyl-Δ ¹ -cyclohexane—1,5-Dimethyl-1-cyclohexene	C ₁₀ H ₁₆	175	
1,5-Dimethyl-Δ ¹ -cyclohexane—1,6-Dimethyl-1-cyclohexene	C ₁₀ H ₁₆	174	
1,6-Dimethyl-Δ ¹ -cyclohexane—1,1-Dimethyl-1-cyclohexene	C ₁₀ H ₁₆	178	
1,1-Dimethyl-Δ ¹ -cyclohexane—1,2-Dimethyl-1-cyclohexene	C ₁₀ H ₁₆	172	
1,2-Dimethyl-Δ ¹ -cyclohexane—1,3-Dimethyl-1-cyclohexene	C ₁₀ H ₁₆	176	
1,3-Dimethyl-Δ ¹ -cyclohexane—1,4-Dimethyl-1-cyclohexene	C ₁₀ H ₁₆	173	
1,4-Dimethyl-Δ ¹ -cyclohexane—1,5-Dimethyl-1-cyclohexene	C ₁₀ H ₁₆	175	
1,5-Dimethyl-Δ ¹ -cyclohexane—1,6-Dimethyl-1-cyclohexene	C ₁₀ H ₁₆	174	
1,6-Dimethyl-Δ ¹ -cyclohexane—1,1-Dimethyl-1-cyclohexene	C ₁₀ H ₁₆	178	
1,1-Dimethyl-Δ ¹ -cyclohexane—1,2-Dimethyl-1-cyclohexene	C ₁₀ H ₁₆	172	
1,2-Dimethyl-Δ ¹ -cyclohexane—1,3-Dimethyl-1-cyclohexene	C ₁₀ H ₁₆	176	
1,3-Dimethyl-Δ ¹ -cyclohexane—1,4-Dimethyl-1-cyclohexene	C ₁₀ H ₁₆	173	
1,4-Dimethyl-Δ ¹ -cyclohexane—1,5-Dimethyl-1-cyclohexene	C ₁₀ H ₁₆	175	
1,5-Dimethyl-Δ ¹ -cyclohexane—1,6-Dimethyl-1-cyclohexene	C ₁₀ H ₁₆	174	
1,6-Dimethyl-Δ ¹ -cyclohexane—1,1-Dimethyl-1-cyclohexene	C ₁₀ H ₁₆	178	

THE PROPERTIES OF PURE HYDROCARBONS

1321

	Ref		Ref		
<i>Paraffins</i>	C ₁₀ H ₂₂	390	Hexatriacontane— <i>n</i> -Hexatriacontane	C ₃₆ H ₇₄	787
<i>Fischerite</i> —Dimethyl-isopropyl-perhydro-phenanthrene	C ₂₁ H ₄₂	662	1,1,5-Hexatriene	C ₆ H ₁₀	56
<i>Fluoranthene</i> —Idryl	C ₁₆ H ₁₀	425	1-Hexene—Butylidene, ω -Hexene	C ₆ H ₁₀	74
<i>Fluorene</i> —Diphenylene-methane	C ₁₆ H ₁₀	133	2-Hexene—1-Methyl-2-propenylidene, β -Hexene	C ₆ H ₁₀	75
<i>Geraniene</i>	C ₁₅ H ₂₆	332	3-Hexene—sym-Dialkylidene, γ -Hexene	C ₆ H ₁₀	76
<i>Geraniolene</i> —2,6-Dimethyl-1,5-heptadiene	C ₁₅ H ₂₆	269	1-Hexene—3,5-Dialkylidene	C ₆ H ₁₀	57
<i>Graphite</i> —Carbon	C	2	1-Hexene—1-Hexene	C ₆ H ₁₀	67
<i>Guaiacene</i>	C ₁₅ H ₂₆	943	2-Hexene—2-Hexene	C ₆ H ₁₀	68
<i>Qualein</i>	C	239	α -Hexylacetylene—1-Cyne	C ₆ H ₁₀	182
also <i>Guaiene</i> —2,3-Dimethylisophtalene	C ₁₅ H ₂₆	461	ω -Hexylene—1-Hexene	C ₆ H ₁₀	74
<i>Guajolene</i>	C ₁₅ H ₂₆	560	β -Hexylene—2-Hexene	C ₆ H ₁₀	75
α - <i>Guajulene</i>	C ₁₅ H ₂₆	561	γ -Hexylene—2-Hexene	C ₆ H ₁₀	76
β - <i>Guajulene</i>	C ₁₅ H ₂₆	562	1-Hexene— n -Butylacetylene, 1-Hexene	C ₆ H ₁₀	67
<i>Hemellitene</i> —1,2,5-Trimethylbenzene	C ₁₀ H ₁₄	241	2-Hexene—Methylpropylacetylene, Hexylene, 2-Hexene	C ₆ H ₁₀	68
<i>Hemilimitene</i> —1,2,3-Trimethylbenzene	C ₁₀ H ₁₄	241	<i>Humulene</i>	C ₃₀ H ₅₀	563
<i>Hemiterpene</i> —2-Methyl-1,3-butadiene	C ₆ H ₁₀	35	<i>Hydrindene</i> —1,2-Dihydroindene, Indan	C ₁₀ H ₁₆	232
n - <i>Heptacosane</i> — n -Heptacosane	C ₂₇ H ₅₆	25	Hydrocarbons—Camphane	C ₁₅ H ₂₄	304
1- <i>Heptadecene</i> —1-Undecene, ω -Undecylene	C ₁₇ H ₃₄	447	<i>Hydrogen</i>	H ₂	1
2- <i>Heptadecene</i> —2-Undecene, β -Undecylene	C ₁₇ H ₃₄	444	Idryl— <i>Fluoranthene</i>	C ₁₆ H ₁₀	323
1- <i>Heptadecyne</i> —1-Undecyne, ω -Nonylacetylene	C ₁₇ H ₃₂	445	Indan— <i>Hydrindene</i>	C ₁₀ H ₁₆	232
α - <i>Heptacosane</i> — α -Heptacosane	C ₂₇ H ₅₆	721	<i>Indene</i>	C ₉ H ₈	230
9- <i>Heptacosane</i> —9-Heptacosane	C ₂₇ H ₅₆	720	α - <i>Ionane</i>	C ₁₁ H ₂₀	
n - <i>Heptacosane</i> — n -Heptacosane	C ₂₇ H ₅₆	721	<i>Isone</i> —1,1,6-Trimethyl-4,9,10-trihydrophenanthrene	C ₁₈ H ₃₂	488
β - <i>Heptacosane</i> — β -Heptacosane	C ₂₇ H ₅₆	720	Isobutylbenzene—1-Propenylidene	C ₉ H ₁₆	233
γ - <i>Heptacosane</i> — γ -Heptacosane	C ₂₇ H ₅₆	720	Isobutylene—Propadiene	C ₄ H ₆	8
δ - <i>Heptacosane</i> — δ -Heptacosane	C ₂₇ H ₅₆	761	Isomethylene—Isopentenylbenzene, 3-Methyl-	C ₁₀ H ₁₈	421
ϵ - <i>Heptacosane</i> — ϵ -Heptacosane	C ₂₇ H ₅₆	666	1-phenylbutene	C ₉ H ₁₆	81
2,4- <i>Heptadiene</i>	C ₇ H ₁₂	107	ω -Isomethylene—3-Methyl-1-butene	C ₁₀ H ₁₈	46
2,6- <i>Heptadiene</i>	C ₇ H ₁₂	107	3-Methyl-2-butene	C ₆ H ₁₀	57
8- <i>Heptacosane</i> — n -Heptacosane	C ₂₇ H ₅₆	721	Isomethylene—3-Methyl-1-hexene	C ₈ H ₁₄	128
Heptatriacontane—Cycloheptane	C ₃₇ H ₇₆	115	Isobutylene—3-Methyl-1-hexene	C ₁₀ H ₁₈	383
<i>n</i> - <i>Heptane</i>	C ₇ H ₁₆	145	Isobutylene	C ₄ H ₈	26
1,1,3- <i>Heptatriene</i>	C ₇ H ₁₂	96	Isobutylene—2-Methylpropane, Trimethylmethane	C ₁₀ H ₁₈	383
1- <i>Heptene</i> — β -Heptylene	C ₇ H ₁₄	122	Isobutylene—2-Methyl-1-phenylpropane,	C ₁₀ H ₁₈	311
2- <i>Heptene</i> — β -Heptylene, 1-Butyl-2-methylethylene	C ₇ H ₁₄	123	(2-Methylpropyl)benzene	C ₁₀ H ₁₈	311
1-Methyl-2-butylidene	C ₇ H ₁₄	124	Isobutylene—2-Methyl-1,1-Dimethylethylene,	C ₈ H ₁₄	24
3- <i>Heptene</i> — β -Heptylene, 1-Ethyl-2-propenylidene	C ₇ H ₁₄	112	α -Butylene, unym-Dimethylethylene	C ₈ H ₁₄	29
1- <i>Heptene</i> —1- <i>Heptyne</i>	C ₇ H ₁₂	112	Isobutylidene—4-Methyl-1-pentene	C ₁₀ H ₁₈	293
2- <i>Heptene</i> —2- <i>Heptyne</i>	C ₇ H ₁₂	113	Isobutylacetyl—2,4-Dimethyl-1-pentene	C ₁₀ H ₁₈	72
3- <i>Heptene</i> —3- <i>Heptyne</i>	C ₇ H ₁₂	114	1-Isobutyl-1-methylidene—2,4-Dimethyl-1-pentene	C ₁₀ H ₁₈	132
4- <i>Heptene</i> —4- <i>Heptyne</i>	C ₇ H ₁₂	122	1-Isobutyl-2-methylidene—2,4-Dimethyl-2-hexene	C ₁₀ H ₁₈	566
α - <i>Heptylene</i> —1- <i>Heptyne</i>	C ₇ H ₁₂	122	<i>Isodulcene</i>	C ₁₀ H ₁₈	59
β - <i>Heptylene</i> —2- <i>Heptyne</i>	C ₇ H ₁₂	123	Isocamphane—Dihydrocamphane, Isohydrocamphane	C ₁₀ H ₁₈	375
3- <i>Heptylene</i> —3- <i>Heptyne</i>	C ₇ H ₁₂	124	Isocamphane—Camphene	C ₁₀ H ₁₈	380
1- <i>Heptyne</i> —1- <i>Heptane</i> , α -Amylacylene, Enehydride	C ₇ H ₁₂	112	iso-carphylene— <i>Carphylene</i>	C ₁₀ H ₁₈	585
2- <i>Heptyne</i> —2- <i>Heptane</i> , Butylmethylacetylene,	C ₇ H ₁₂	113	Isocryene—Triphenylene	C ₁₀ H ₁₈	671
Methylbutylacetylene	C ₇ H ₁₂	114	<i>Isodulcene</i>	C ₁₀ H ₁₈	365
3- <i>Heptyne</i> —3- <i>Heptane</i>	C ₇ H ₁₂	114	Isocymene— m -Cymene	C ₁₀ H ₁₈	311
Heptadecene— <i>Limonene</i>	C ₁₇ H ₃₄	348	Isodihydrocarophyllene	C ₁₀ H ₁₈	597
Hexaheptacosane— <i>Coronene</i>	C ₂₆ H ₅₂	732	Isodiphenylbenzene—1,3-Diphenylbenzene	C ₁₀ H ₁₈	672
n - <i>Hexacosane</i> — n -Hexacosane	C ₂₆ H ₅₂	704	Isodiphenylbenzene—2,4-Cymene	C ₁₀ H ₁₈	337
α - <i>Hexacosane</i> — α -Hexacosane	C ₂₆ H ₅₂	753	Isodulcene—1,2,3,5-Tetramethylbenzene	C ₁₀ H ₁₈	328
β - <i>Hexacosane</i> — β -Hexacosane	C ₂₆ H ₅₂	659	Isodimethylene—5-Fenchene	C ₁₀ H ₁₈	363
1- <i>Hexadecene</i> —1-Hexadecene, Cetene	C ₁₆ H ₃₂	658	Isoparalocane—2,6-Dimethyl-1,3-heptadiene	C ₁₀ H ₁₈	268
2- <i>Hexadecene</i> —2- <i>Hexadecyne</i>	C ₁₆ H ₃₂	657	Isopentane—2-Methylidene	C ₅ H ₁₀	146
Hexadecylacetylene—1- <i>Octadecyne</i>	C ₁₆ H ₃₂	683	Isopentane—3-Methyl-1-hexene	C ₆ H ₁₂	128
n - <i>Hexadecane</i> —1- <i>Hexadecene</i>	C ₁₆ H ₃₂	658	Isopentane—2-Methylidene	C ₅ H ₁₀	754
3- <i>Hexadecene</i> —3- <i>Hexadecane</i> , Cetylene	C ₁₆ H ₃₂	657	Isopentane—3-Methylpentacosane	C ₁₆ H ₃₂	754
1,3- <i>Hexadiene</i> —Diallyl Biallyl	C ₁₀ H ₁₆	62	Isopentane—2-Methylpentane	C ₅ H ₁₀	88
2,4- <i>Hexadiene</i> —Dipropargyl, 1,4-Dimethylbutadiene	C ₁₀ H ₁₆	63	Isopentylene—4-Methyl-1-phenylpentane	C ₁₀ H ₁₈	465
Bipropargyl, Dipropargyl	C ₁₀ H ₁₆	63	Isopentylene—2,3,3-Trimethyl-1-cyclopentane	C ₁₀ H ₁₈	181
1,3- <i>Hexadiene</i> —3- <i>Hexene</i> , Divinylacetylene	C ₆ H ₁₀	52	Isopentylene—2,3,3-Trimethyl-1-cyclopentane	C ₁₀ H ₁₈	385
1,5- <i>Hexadiene</i> —1,3- <i>Hexadiene</i>	C ₆ H ₁₀	53	Isopentylene—2,3,3-Trimethyl-1-cyclopentane	C ₁₀ H ₁₈	181
Hexadecene—1,3- <i>Hexadiene</i>	C ₆ H ₁₀	53	Isopentylene—2,3,3-Trimethyl-1-cyclopentane	C ₁₀ H ₁₈	385
1,3- <i>Hexadiene</i> —Hexadecene, 1,5- <i>Hexadiene</i> ,	C ₆ H ₁₀	53	Isopentylene—2,3,3-Trimethyl-1-cyclopentane	C ₁₀ H ₁₈	385
Dipropargyl, Bipropargyl	C ₁₀ H ₁₆	63	Isopentylene—2,3,3-Trimethyl-1-cyclopentane	C ₁₀ H ₁₈	385
<i>Hexatriene</i>	C ₆ H ₁₀	53	Isopentylene—2,3,3-Trimethyl-1-cyclopentane	C ₁₀ H ₁₈	385
α - <i>Hexatriacontane</i> — α -Anthracene—hexahydride	C ₃₆ H ₇₂	461	Isopentylene—2,3,3-Trimethyl-1-cyclopentane	C ₁₀ H ₁₈	385
Hexahydrobenzene—Cyclohexane	C ₆ H ₁₂	516	Isopentylene—2,3,3-Trimethyl-1-cyclopentane	C ₁₀ H ₁₈	385
Hexahydrodibenzene	C ₁₂ H ₂₀	69	Isopentylene—2,3,3-Trimethyl-1-cyclopentane	C ₁₀ H ₁₈	385
Hexahydrodecane—Isopropylcyclohexane	C ₁₂ H ₂₀	612	Isopentylene—2,3,3-Trimethyl-1-cyclopentane	C ₁₀ H ₁₈	385
Hexahydrododecane	C ₁₄ H ₂₄	775	Isopentylene—2,3,3-Trimethyl-1-cyclopentane	C ₁₀ H ₁₈	385
Hexahydrooctadecane—Isopropylcyclohexane	C ₁₈ H ₃₂	610	Isopentylene—2,3,3-Trimethyl-1-cyclopentane	C ₁₀ H ₁₈	385
Hexahydro- α -curcumene	C ₁₈ H ₃₂	611	Isopentylene—2,3,3-Trimethyl-1-cyclopentane	C ₁₀ H ₁₈	385
Hexahydro- β -curcumene	C ₁₈ H ₃₂	611	Isopentylene—2,3,3-Trimethyl-1-cyclopentane	C ₁₀ H ₁₈	385
Hexahydrocymene— α -Menthane	C ₁₀ H ₁₈	397	Isopentylene—2,3,3-Trimethyl-1-cyclopentane	C ₁₀ H ₁₈	385
1,2,3,4,5-Hexahydrodiphenyl—Phenylcyclohexane	C ₁₆ H ₂₄	464	Isopentylene—2,3,3-Trimethyl-1-cyclopentane	C ₁₀ H ₁₈	385
Hexahydroolefene	C ₁₀ H ₁₈	614	Isopentylene—2,3,3-Trimethyl-1-cyclopentane	C ₁₀ H ₁₈	385
Hexahydrooctylene—1,3,5-Trimethylcyclohexane	C ₁₂ H ₂₀	281	Isopentylene—2,3,3-Trimethyl-1-cyclopentane	C ₁₀ H ₁₈	385
Hexahydrophenanthrene	C ₁₄ H ₂₄	307	Isopentylene—2,3,3-Trimethyl-1-cyclopentane	C ₁₀ H ₁₈	385
Hexahydrotricyclic—Methylcyclohexane	C ₁₀ H ₁₈	116	Isopentylene—2,3,3-Trimethyl-1-cyclopentane	C ₁₀ H ₁₈	385
Hexahydro- α -ylene—1,3-Dimethylcyclohexane	C ₁₀ H ₁₈	196	Isopentylene—2,3,3-Trimethyl-1-cyclopentane	C ₁₀ H ₁₈	385
Hexahydro- β -ylene—1,3-Dimethylcyclohexane	C ₁₀ H ₁₈	197	Isopentylene—2,3,3-Trimethyl-1-cyclopentane	C ₁₀ H ₁₈	385
Hexahydro- γ -ylene—1,6-Dimethylcyclohexane	C ₁₀ H ₁₈	198	Isopentylene—2,3,3-Trimethyl-1-cyclopentane	C ₁₀ H ₁₈	385
Hexahydro- δ -ylene—1,6-Dimethylcyclohexane	C ₁₀ H ₁₈	198	Isopentylene—2,3,3-Trimethyl-1-cyclopentane	C ₁₀ H ₁₈	385
Hexahydro- ϵ -ylene—1,6-Dimethylcyclohexane	C ₁₀ H ₁₈	198	Isopentylene—2,3,3-Trimethyl-1-cyclopentane	C ₁₀ H ₁₈	385
Hexahydro- ζ -ylene—1,6-Dimethylcyclohexane	C ₁₀ H ₁₈	198	Isopentylene—2,3,3-Trimethyl-1-cyclopentane	C ₁₀ H ₁₈	385
Hexahydro- η -ylene—1,6-Dimethylcyclohexane	C ₁₀ H ₁₈	198	Isopentylene—2,3,3-Trimethyl-1-cyclopentane	C ₁₀ H ₁₈	385
Hexahydro- θ -ylene—1,6-Dimethylcyclohexane	C ₁₀ H ₁₈	198	Isopentylene—2,3,3-Trimethyl-1-cyclopentane	C ₁₀ H ₁₈	385
Hexahydro- ι -ylene—1,6-Dimethylcyclohexane	C ₁₀ H ₁₈	198	Isopentylene—2,3,3-Trimethyl-1-cyclopentane	C ₁₀ H ₁₈	385
Hexahydro- κ -ylene—1,6-Dimethylcyclohexane	C ₁₀ H ₁₈	198	Isopentylene—2,3,3-Trimethyl-1-cyclopentane	C ₁₀ H ₁₈	385
Hexahydro- λ -ylene—1,6-Dimethylcyclohexane	C ₁₀ H ₁₈	198	Isopentylene—2,3,3-Trimethyl-1-cyclopentane	C ₁₀ H ₁₈	385
Hexahydro- μ -ylene—1,6-Dimethylcyclohexane	C ₁₀ H ₁₈	198	Isopentylene—2,3,3-Trimethyl-1-cyclopentane	C ₁₀ H ₁₈	385
Hexahydro- ν -ylene—1,6-Dimethylcyclohexane	C ₁₀ H ₁₈	198	Isopentylene—2,3,3-Trimethyl-1-cyclopentane	C ₁₀ H ₁₈	385
Hexahydro- ξ -ylene—1,6-Dimethylcyclohexane	C ₁₀ H ₁₈	198	Isopentylene—2,3,3-Trimethyl-1-cyclopentane	C ₁₀ H ₁₈	385
Hexahydro- \omicron -ylene—1,6-Dimethylcyclohexane	C ₁₀ H ₁₈	198	Isopentylene—2,3,3-Trimethyl-1-cyclopentane	C ₁₀ H ₁₈	385
Hexahydro- π -ylene—1,6-Dimethylcyclohexane	C ₁₀ H ₁₈	198	Isopentylene—2,3,3-Trimethyl-1-cyclopentane	C ₁₀ H ₁₈	385
Hexahydro- ρ -ylene—1,6-Dimethylcyclohexane	C ₁₀ H ₁₈	198	Isopentylene—2,3,3-Trimethyl-1-cyclopentane	C ₁₀ H ₁₈	385
Hexahydro- σ -ylene—1,6-Dimethylcyclohexane	C ₁₀ H ₁₈	198	Isopentylene—2,3,3-Trimethyl-1-cyclopentane	C ₁₀ H ₁₈	385
Hexahydro- τ -ylene—1,6-Dimethylcyclohexane	C ₁₀ H ₁₈	198	Isopentylene—2,3,3-Trimethyl-1-cyclopentane	C ₁₀ H ₁₈	385
Hexahydro- υ -ylene—1,6-Dimethylcyclohexane	C ₁₀ H ₁₈	198	Isopentylene—2,3,3-Trimethyl-1-cyclopentane	C ₁₀ H ₁₈	385
Hexahydro- ϕ -ylene—1,6-Dimethylcyclohexane	C ₁₀ H ₁₈	198	Isopentylene—2,3,3-Trimethyl-1-cyclopentane	C ₁₀ H ₁₈	385
Hexahydro- χ -ylene—1,6-Dimethylcyclohexane	C ₁₀ H ₁₈	198	Isopentylene—2,3,3-Trimethyl-1-cyclopentane	C ₁₀ H ₁₈	385
Hexahydro- ψ -ylene—1,6-Dimethylcyclohexane	C ₁₀ H ₁₈	198	Isopentylene—2,3,3-Trimethyl-1-cyclopentane	C ₁₀ H ₁₈	385
Hexahydro- ω -ylene—1,6-Dimethylcyclohexane	C ₁₀ H ₁₈	198	Isopentylene—2,3,3-Trimethyl-1-cyclopentane	C ₁₀ H ₁₈	385
Hexahydro- α -ylene—1,6-Dimethylcyclohexane	C ₁₀ H ₁₈	198	Isopentylene—2,3,3-Trimethyl-1-cyclopentane	C ₁₀ H ₁₈	385
Hexahydro- β -					

1-Methyl-4-isopropoxy-2-cyclohexane— <i>Inulinone</i>	C ₁₂ H ₂₀	349	1-Methyl-2-propylbenzene— <i>n</i> -Propyltoluene	C ₁₀ H ₁₈	317
1-Methyl-2-isopropylbenzene— <i>o</i> -Cymene	C ₁₀ H ₁₈	314	1-Methyl-3-propylbenzene— <i>p</i> -Propyltoluene	C ₁₀ H ₁₈	318
1-Methyl-3-isopropylbenzene— <i>m</i> -Cymene	C ₁₀ H ₁₈	315	1-Methyl-4-propylbenzene— <i>p</i> -Propyltoluene	C ₁₀ H ₁₈	319
1-Methyl-4-isopropylbenzene— <i>p</i> -Cymene	C ₁₀ H ₁₈	316	1-Methyl-4-propylcyclohexane	C ₁₁ H ₂₀	394
2-Methyl-4-isopropylbutane-1,3—2,3-Dimethyl-3-hexadecane	C ₁₈ H ₃₈	187	1-Methyl-1-propylthylene—2-Methyl-1-pentene	C ₆ H ₁₂	75
1-Methyl-4-isopropyl-1,3-cyclohexadiene— <i>Terpinene</i>	C ₁₀ H ₁₈	342	Methyl-3-propylthiopyranose	C ₁₁ H ₂₀	375
1-Methyl-4-isopropyl-1,4-cyclohexadiene— <i>Terpinene</i>	C ₁₀ H ₁₈	344	Methyl-3-propylthiopyranose	C ₁₁ H ₂₀	376
1-Methyl-4-isopropyl-1,5-cyclohexadiene— <i>Phelandrene</i>	C ₁₀ H ₁₈	345	Methylpropylpropylmethane—2,3-Dimethylhexane	C ₈ H ₁₈	221
1-Methyl-2-isopropylcyclohexane— <i>o</i> -Menthane	C ₁₀ H ₁₈	395	n-Methylulbene—1,3-Diphenyl-1-propylene	C ₁₆ H ₁₈	533
1-Methyl-3-isopropylcyclohexane— <i>m</i> -Menthane	C ₁₀ H ₁₈	396	2-Methyl-6-(<i>o</i> -tolyl)heptane	C ₁₆ H ₂₆	577
1-Methyl-4-isopropylcyclohexane— <i>p</i> -Menthane	C ₁₀ H ₁₈	397	2-Methylulbene—Isotetracosane, Isotetracosane	C ₂₄ H ₅₀	740
Methyl-4-isopropyl-1-cyclohexane— δ^1 - <i>n</i> -Menthane	C ₁₀ H ₁₈	378	1-Methylphenylmethane—Diphenyl- <i>o</i> -tolylmethane	C ₁₆ H ₁₈	700
Methyl-4-isopropyl-3-cyclohexane— δ^2 - <i>n</i> -Menthane	C ₁₀ H ₁₈	379	3-Methylphenylmethane—Diphenyl- <i>m</i> -tolylmethane	C ₁₆ H ₁₈	701
1-Methyl-2-isopropylcyclopentane	C ₉ H ₁₈	382	4-Methylphenylmethane—Diphenyl- <i>p</i> -tolylmethane	C ₁₆ H ₁₈	702
1-Methyl-3-isopropylcyclopentane	C ₉ H ₁₈	283	n-Methyltritan—1,1,7-Triphenylthene	C ₁₆ H ₁₈	706
3-Methyl-1-isopropyl-1-cyclopentane— <i>Palenone</i>	C ₉ H ₁₈	289	2 Methyltritan—Diphenyl- <i>o</i> -tolylmethane	C ₁₆ H ₁₈	700
1-Methyl-3-isopropylcyclopentane	C ₉ H ₁₈	121	3-Methyltritan—Diphenyl- <i>m</i> -tolylmethane	C ₁₆ H ₁₈	701
1-Methyl-4-isopropylerythrene—2,3-Dimethyl-1,3-hexadecane	C ₁₈ H ₃₈	187	4-Methyltritan—Diphenyl- <i>p</i> -tolylmethane	C ₁₆ H ₁₈	702
1-Methyl-1-isopropylthylene—2,3-Dimethyl-1-butene	C ₈ H ₁₆	83	Moisone— <i>Terpinene</i>	C ₁₀ H ₁₈	344
Methyl-4-isopropylidene-cyclohexane—2 ¹⁰ <i>o</i> -Menthane	C ₁₁ H ₂₀	376	<i>Myrcene</i> —2 Methyl-6-methylene-2,7-octadiene	C ₁₁ H ₂₀	368
Dihydroterpinolene	C ₁₀ H ₁₈	380	Naphthalene—Decahydroanthracene	C ₁₀ H ₁₈	271
1-Methyl-4-isopropylidene-1-cyclohexane— <i>Terpinolene</i>	C ₁₁ H ₂₀	347	Naphthalene	C ₁₀ H ₈	398
1-Methyl-7-isopropylphenanthrene— <i>Eudalene</i>	C ₁₈ H ₃₀	577	Naphthalene-2,3-dihydro-1,2-Dihydroanthracene	C ₁₂ H ₂₀	399
2-Methyl-8-isopropylphenanthrene— <i>Apocadene</i>	C ₁₈ H ₃₀	517	Naphthalene-1,4-dihydro-1,6-Dihydroanthracene	C ₁₂ H ₂₀	300
1-Methyl-7-isopropylphenanthrene— <i>Retene</i>	C ₁₈ H ₃₀	675	Naphthalene—Decahydroanthracene	C ₁₀ H ₁₈	371
n-Methylulbene— <i>Ebene</i>	C ₈ H ₁₆	7	n-Naphthalene— <i>Acenaphthene</i>	C ₁₀ H ₈	351
1-Methyl-3-methenecyclohexane—1 Methyl-3-methylcyclohexane	C ₈ H ₁₆	170	1-Naphthylphenylmethane—1-Benzylanthracene	C ₁₆ H ₁₈	661
1-Methyl-4-methenecyclohexane—1-Methyl-4-methylcyclohexane	C ₈ H ₁₆	171	2 Naphthylphenylmethane—2-Benzylanthracene	C ₁₆ H ₁₈	662
1-Methyl-3-methenecyclopentane—Methyl-3-methylcyclopentane	C ₇ H ₁₄	104	Norbornane—2,2-Dimethylbutane	C ₇ H ₁₄	90
1-Methyl-4-methenecyclopentane—1-Methyl-3-methenecyclohexane	C ₈ H ₁₆	170	Norbornane—2,3-Dimethylbutane	C ₇ H ₁₄	90
1-Methyl-4-methylcyclohexane—1-Methyl-4-methenecyclohexane	C ₈ H ₁₆	171	n-Nonacosane—Nonacosane, Nonacosane	C ₂₉ H ₆₀	769
Methyl-3-methenecyclopentane—1-Methyl-3-methenecyclohexane	C ₈ H ₁₆	104	Nonacosane— <i>n</i> -Nonacosane	C ₂₉ H ₆₀	769
1-Methyl-6-methylcyclohexane—1-Methyl-6-methenecyclohexane	C ₈ H ₁₆	171	Nonacosane— <i>n</i> -Nonacosane	C ₂₉ H ₆₀	769
Methyl-3-methenecyclopentane—1-Methyl-3-methenecyclopentane	C ₇ H ₁₄	104	Nonacosane— <i>n</i> -Nonacosane	C ₂₉ H ₆₀	769
2-Methyl-6-methylene-2,7-octadiene— <i>Myrcene</i>	C ₁₀ H ₁₈	104	Nonacosane— <i>n</i> -Nonacosane	C ₂₉ H ₆₀	769
2-Methyl-3-methylthylene—2-Methyl-2-methyl-1-butene	C ₈ H ₁₆	368	Nonacosane— <i>n</i> -Nonacosane	C ₂₉ H ₆₀	769
1-Methylisopthalene— β -Methylisopthalene	C ₁₀ H ₁₈	418	Nonacosane— <i>n</i> -Nonacosane	C ₂₉ H ₆₀	769
2-Methylisopthalene— β -Methylisopthalene	C ₁₀ H ₁₈	419	Nonacosane— <i>n</i> -Nonacosane	C ₂₉ H ₆₀	769
n-Methylisopthalene— β -Methylisopthalene	C ₁₀ H ₁₈	418	Nonacosane— <i>n</i> -Nonacosane	C ₂₉ H ₆₀	769
β -Methylisopthalene—2-Methylisopthalene	C ₁₀ H ₁₈	419	Nonacosane— <i>n</i> -Nonacosane	C ₂₉ H ₆₀	769
2-Methylisopthalene	C ₁₀ H ₁₈	419	Nonacosane— <i>n</i> -Nonacosane	C ₂₉ H ₆₀	769
3-Methylisopthalene	C ₁₀ H ₁₈	184	Nonacosane— <i>n</i> -Nonacosane	C ₂₉ H ₆₀	769
5-Methylisopthalene	C ₁₀ H ₁₈	263	Nonacosane— <i>n</i> -Nonacosane	C ₂₉ H ₆₀	769
4-Methyl-3,3-octadiene	C ₈ H ₁₆	217	Nonacosane— <i>n</i> -Nonacosane	C ₂₉ H ₆₀	769
7-Methyl-2,6-octadiene	C ₈ H ₁₆	289	Nonacosane— <i>n</i> -Nonacosane	C ₂₉ H ₆₀	769
2-Methylthiopyranose	C ₆ H ₁₂	388	Nonacosane— <i>n</i> -Nonacosane	C ₂₉ H ₆₀	769
4-Methylthiopyranose	C ₆ H ₁₂	266	Nonacosane— <i>n</i> -Nonacosane	C ₂₉ H ₆₀	769
2-Methylthiopyranose	C ₆ H ₁₂	289	Nonacosane— <i>n</i> -Nonacosane	C ₂₉ H ₆₀	769
2-Methylpentacosane—Isotetracosane, Cerane Isotetracosane	C ₂₅ H ₅₂	290	Nonacosane— <i>n</i> -Nonacosane	C ₂₉ H ₆₀	769
1-Methyl-2-pentadecylacetylene—2-Octadecyne	C ₁₇ H ₃₄	684	Nonacosane— <i>n</i> -Nonacosane	C ₂₉ H ₆₀	769
2-Methyl-2-pentadecylacetylene—Trimethylallene	C ₁₇ H ₃₄	65	Nonacosane— <i>n</i> -Nonacosane	C ₂₉ H ₆₀	769
3-Methyl-1,3-pentadiene	C ₆ H ₁₀	64	Nonacosane— <i>n</i> -Nonacosane	C ₂₉ H ₆₀	769
2-Methylpentene—Dimethylpropylmethane, Isobutene	C ₆ H ₁₂	88	Nonacosane— <i>n</i> -Nonacosane	C ₂₉ H ₆₀	769
3-Methylpentene—Methylisobutylene	C ₆ H ₁₂	89	Nonacosane— <i>n</i> -Nonacosane	C ₂₉ H ₆₀	769
2-Methyl-3-pentene—2-Ethyl-1,1-dimethylthylene	C ₆ H ₁₂	82	Nonacosane— <i>n</i> -Nonacosane	C ₂₉ H ₆₀	769
3-Methyl-1-pentene—1-Methyl-1-propenylthylene	C ₆ H ₁₂	80	Nonacosane— <i>n</i> -Nonacosane	C ₂₉ H ₆₀	769
2-Methyl-3-pentene—2-Ethyl-1,1-dimethylthylene	C ₆ H ₁₂	82	Nonacosane— <i>n</i> -Nonacosane	C ₂₉ H ₆₀	769
3-Methyl-1-pentene—1-Methyl-1-propenylthylene	C ₆ H ₁₂	78	Nonacosane— <i>n</i> -Nonacosane	C ₂₉ H ₆₀	769
5-Methyl-3-pentene—1-Ethyl-1,2-dimethylthylene	C ₆ H ₁₂	81	Nonacosane— <i>n</i> -Nonacosane	C ₂₉ H ₆₀	769
4-Methyl-1-pentene—Isobutylthylene	C ₆ H ₁₂	79	Nonacosane— <i>n</i> -Nonacosane	C ₂₉ H ₆₀	769
4-Methyl-3-pentene—2-Methyl-3-pentene, 1-Isopropyl-2-methylthylene	C ₆ H ₁₂	82	Nonacosane— <i>n</i> -Nonacosane	C ₂₉ H ₆₀	769
1-Methylphenanthrene	C ₁₈ H ₃₀	530	Nonacosane— <i>n</i> -Nonacosane	C ₂₉ H ₆₀	769
3-Methylphenanthrene	C ₁₈ H ₃₀	531	Nonacosane— <i>n</i> -Nonacosane	C ₂₉ H ₆₀	769
Methylphenanthrylene—1-Propylphenanthrene	C ₁₈ H ₃₀	231	Nonacosane— <i>n</i> -Nonacosane	C ₂₉ H ₆₀	769
1-Methyl-1-phenylbenzene— <i>o</i> -Phenyltoluene, 2-Methylidiphenyl	C ₁₄ H ₁₈	483	Nonacosane— <i>n</i> -Nonacosane	C ₂₉ H ₆₀	769
1-Methyl-3-phenylbenzene— <i>m</i> -Phenyltoluene, 3-Methylidiphenyl	C ₁₄ H ₁₈	486	Nonacosane— <i>n</i> -Nonacosane	C ₂₉ H ₆₀	769
1-Methyl-4-phenylbenzene— <i>p</i> -Phenyltoluene, 4-Methylidiphenyl	C ₁₄ H ₁₈	487	Nonacosane— <i>n</i> -Nonacosane	C ₂₉ H ₆₀	769
3-Methyl-1-phenylthylene— <i>n</i> -Butylbenzene	C ₁₀ H ₁₈	421	Nonacosane— <i>n</i> -Nonacosane	C ₂₉ H ₆₀	769
2-Methyl-2-phenylthylene— <i>tert</i> -Amylbenzene	C ₁₀ H ₁₈	423	Nonacosane— <i>n</i> -Nonacosane	C ₂₉ H ₆₀	769
unsym-Methylphenylthylene—Isopropylbenzene	C ₁₀ H ₁₈	235	Nonacosane— <i>n</i> -Nonacosane	C ₂₉ H ₆₀	769
2-Methylphenylthylene	C ₁₀ H ₁₈	235	Nonacosane— <i>n</i> -Nonacosane	C ₂₉ H ₆₀	769
4-Methyl-1-phenylpentane— <i>Isobutylbenzene</i>	C ₁₁ H ₂₀	465	Nonacosane— <i>n</i> -Nonacosane	C ₂₉ H ₆₀	769
2-Methyl-1-phenylpropane— <i>Isobutylbenzene</i>	C ₁₁ H ₂₀	311	Nonacosane— <i>n</i> -Nonacosane	C ₂₉ H ₆₀	769
2-Methyl-3-phenylpropane— <i>tert</i> -Butylbenzene	C ₁₁ H ₂₀	313	Nonacosane— <i>n</i> -Nonacosane	C ₂₉ H ₆₀	769
2-Methylpropane— <i>Isobutene</i>	C ₄ H ₈	25	Nonacosane— <i>n</i> -Nonacosane	C ₂₉ H ₆₀	769
2-Methyl-1-propane— <i>Isobutylene</i>	C ₄ H ₈	24	Nonacosane— <i>n</i> -Nonacosane	C ₂₉ H ₆₀	769
1-Methyl-1-propenylbenzene—2-Phenyl-2-butene, β -Phenyl-1-butylene	C ₁₁ H ₂₀	306	Nonacosane— <i>n</i> -Nonacosane	C ₂₉ H ₆₀	769
Methylpropylacetylene—2-Hexyne	C ₈ H ₁₆	68	Nonacosane— <i>n</i> -Nonacosane	C ₂₉ H ₆₀	769
1-Methylpropylbenzene—2-Phenylbutane, <i>sec</i> -Butylbenzene	C ₁₁ H ₂₀	312	Nonacosane— <i>n</i> -Nonacosane	C ₂₉ H ₆₀	769
2-Methylpropylbenzene— <i>Isobutylbenzene</i>	C ₁₁ H ₂₀	311	Nonacosane— <i>n</i> -Nonacosane	C ₂₉ H ₆₀	769

	Ref no		Ref no		
Tetrahydrozingerone	C ₁₅ H ₁₆	601	1,7,7-Trimethylbicyclo[2,2,1]heptane—Camphane	C ₁₅ H ₁₆	384
1,2,3,4-Tetrahydroquinoline—5,6,7,8-Tetrahydro-naphthalene	C ₁₇ H ₁₈	305	1,7,7-Trimethylbicyclo[2,2,2]heptane—2-Borylene	C ₁₅ H ₁₆	377
5,6,7,8-Tetrahydronaphthalene—1,2,3,4-Tetrahydro-naphthalene	C ₁₅ H ₁₆	305	2,6,6-Trimethylbicyclo[2,1,1]hept-2-ene—Borne	C ₁₅ H ₁₆	335c
Tetrahydro- <i>n</i> -undecane	C ₁₅ H ₁₆	608	2,2,3-Trimethylbutane—Trimethylisopropylmethane	C ₁₅ H ₁₆	153
Tetrahydro- <i>n</i> -undecane	C ₁₅ H ₁₆	609	2,3,3-Trimethyl-1-butene—2,2,3-Trimethyl-3-butene	C ₁₅ H ₁₆	143
Tetrahydrooctalene	C ₁₅ H ₁₆	607	2,2,3,3-Trimethylbutane—2,3,3-Trimethyl-1-butene	C ₁₅ H ₁₆	143
Tetrahydrooctalene—Tetrahydrodecalene	C ₁₅ H ₁₆	603	(1,1,3-Trimethylbutylidene)—2,2-Cyclohexyl-2,4-dimethylpentane	C ₁₅ H ₁₆	490
Δ ¹ -Tetrahydrotriatene—Methyl-1-cyclohexene	C ₁₅ H ₁₆	99	Trimethyl- <i>n</i> -undecylmethane—2,3-Dimethylcyclohexane	C ₁₅ H ₁₆	229
Δ ¹ -Tetrahydrotriatene	C ₁₅ H ₁₆	100	Trimethyl-tertbutylmethane—2,2,3,3-Tetramethylbutane	C ₁₅ H ₁₆	490
Δ ¹ -Tetrahydrotriatene—Methyl-3-cyclohexene	C ₁₅ H ₁₆	101	1,1,3-Trimethylcyclohexane	C ₁₅ H ₁₆	278
1,2,3,4-Tetrahydrotriatene—Methyl-3-cyclohexene	C ₁₅ H ₁₆	101	1,2,2-Trimethylcyclohexane	C ₁₅ H ₁₆	279
1,2,3,4-Tetrahydro- <i>m</i> -xylene—3,5-Dimethyl-1-cyclohexene	C ₁₅ H ₁₆	101	1,2,2-Trimethylcyclohexane	C ₁₅ H ₁₆	280
Δ ¹ -Tetrahydro- <i>m</i> -xylene—1,4-Dimethyl-1-cyclohexene	C ₁₅ H ₁₆	101	1,2,2-Trimethylcyclohexane—Hexahydrodecalene	C ₁₅ H ₁₆	281
Δ ¹ -Tetrahydro- <i>m</i> -xylene—1,5-Dimethyl-1-cyclohexene	C ₁₅ H ₁₆	101	1,1,1-Trimethyl-2-cyclohexane—β-Cylogeronolene	C ₁₅ H ₁₆	254
Δ ¹ -Tetrahydro- <i>m</i> -xylene—1,5-Dimethyl-1-cyclohexene	C ₁₅ H ₁₆	101	1,1,3-Trimethyl-3-cyclohexane—Cyclogeronolene	C ₁₅ H ₁₆	254
Δ ¹ -Tetrahydro- <i>m</i> -xylene—1,6-Dimethyl-1-cyclohexene	C ₁₅ H ₁₆	101	1,2,5-Trimethyl-4-cyclohexane—1,4,5-Trimethyl-1-cyclohexene	C ₁₅ H ₁₆	254
Δ ¹ -Tetrahydro- <i>m</i> -xylene—1,5-Dimethyl-1-cyclohexene	C ₁₅ H ₁₆	101	1,3,5-Trimethyl-1-cyclohexene	C ₁₅ H ₁₆	253
Δ ¹ -Tetrahydro- <i>m</i> -xylene—1,5-Dimethyl-1-cyclohexene	C ₁₅ H ₁₆	101	1,4,5-Trimethyl-1-cyclohexene—1,2,5-Trimethyl-4-cyclohexane	C ₁₅ H ₁₆	254
Δ-Tetracosane— <i>n</i> -Tetracosane	C ₂₈ H ₅₈	739	1,1,2-Trimethylcyclopentane	C ₁₅ H ₁₆	202
Tetramethylsilane—2,4-Dimethyl-2-pentadecane	C ₁₅ H ₁₆	111	1,2,4-Trimethylcyclopentane	C ₁₅ H ₁₆	203
1,3,5,7-Tetramethylsiloxane	C ₁₅ H ₁₆	676	1,2,3-Trimethyl-1-cyclopentane—Laurilene	C ₁₅ H ₁₆	180
1,2,3,4-Tetramethylbenzene—Prelutene, Prelutole	C ₁₅ H ₁₆	327	1,2,3,3-Trimethyl-1-cyclopentane—Isolaurilene	C ₁₅ H ₁₆	181
1,2,3,3-Tetramethylbenzene—Isolaurilene	C ₁₅ H ₁₆	328	1,1,2-Trimethylcyclopentane	C ₁₅ H ₁₆	72
1,3,4,5-Tetramethylbenzene—Durane Durol	C ₁₅ H ₁₆	329	1,2,3-Trimethylcyclopentane	C ₁₅ H ₁₆	73
2,2,3,5-Tetramethylbenzene—Trimethyl-tertbutylmethane	C ₁₅ H ₁₆	329	1,2,2,4-Trimethyl-1,6-dihydrobenzene—Dihydro- <i>o</i> -cumene	C ₁₅ H ₁₆	247
Bi-tertbutyl, Hexamethylthane	C ₁₅ H ₁₆	229	2,6,10-Trimethyldecane—Farnesene	C ₁₅ H ₁₆	616
1,2,4,5-Tetramethylcyclohexane	C ₁₅ H ₁₆	398	Trimethylene—Cyclopentane	C ₁₅ H ₁₆	10
1,2,4,5-Tetramethylcyclohexane	C ₁₅ H ₁₆	398	Trimethylcyclohexane—3-Methyl-1-butene	C ₁₅ H ₁₆	47
1,2,3,3-Tetramethyl-1-cyclopentane—Camphole	C ₁₅ H ₁₆	263	Trimethylcyclohexane—2,3-Dimethyl-2-pentene	C ₁₅ H ₁₆	138
1,1,3,3-Tetramethyl-2,4-dimethylcyclobutane	C ₁₅ H ₁₆	367	Trimethylcyclohexane—2,2-Dimethylbutane	C ₁₅ H ₁₆	90
4,8,12,16-Tetramethylcyclohexane—Bixane	C ₁₅ H ₁₆	741	2,3,3-Trimethyl-3-heptene—3,3,5-Trimethyl-4-heptane	C ₁₅ H ₁₆	409
Tetramethylcyclobutane	C ₁₅ H ₁₆	20	2,2,3-Trimethyl-4-heptene—3,5,5-Trimethyl-3-heptene	C ₁₅ H ₁₆	295
sym-Tetramethylcyclobutane—2,3-Dimethylbutane	C ₁₅ H ₁₆	91	1,2,3-Trimethyl-3-isopropylcyclobutane	C ₁₅ H ₁₆	401
Tetramethylcyclobutane—2,3-Dimethyl-2-butene	C ₁₅ H ₁₆	86	2,2,3-Trimethyl-3-isopropylcyclobutane	C ₁₅ H ₁₆	401
2,6,11,15-Tetramethyldecane—Cycetane	C ₁₅ H ₁₆	710	2,2,3-Trimethyl-3-isopropylcyclobutane	C ₁₅ H ₁₆	401
Tetramethylmethane—2,2-Dimethylpropane	C ₁₅ H ₁₆	50	Trimethylmethane—Isobutane	C ₁₅ H ₁₆	26
2,4,5,7-Tetramethylbutane	C ₁₅ H ₁₆	482	2,5,6-Trimethyl-4-nonene	C ₁₅ H ₁₆	478
<i>n</i> -Tetrapentadecane	C ₁₅ H ₁₆	394	1,7,7-Trimethylnonadecane—Camphane	C ₁₅ H ₁₆	384
Tetraphenylsilane—Tetraphenylpropadiene	C ₁₅ H ₁₆	755	1,1-Trimethyl-4- <i>n</i> -tridecane—Phenylisobutylmethane	C ₁₅ H ₁₆	224
1,1,1,2-Tetraphenylsilane	C ₁₅ H ₁₆	750	2,4-4-Trimethyl-1-pentene—Diisobutylene	C ₁₅ H ₁₆	113
1,1,2,2-Tetraphenylsilane—sym-Tetraphenylsilane	C ₁₅ H ₁₆	751	2,4-4-Trimethyl-2-pentene—Diisobutylene	C ₁₅ H ₁₆	214
sym-Tetraphenylsilane—1,1,2,2-Tetraphenylsilane	C ₁₅ H ₁₆	751	Trimethylisopropylmethane—2,2-Dimethylpentane	C ₁₅ H ₁₆	149
Tetraphenylsilane	C ₁₅ H ₁₆	749	ω-Trimethylsiloxane— <i>tert</i> -Butylbenzene	C ₁₅ H ₁₆	313
Tetraphenylmethane	C ₁₅ H ₁₆	742	1,1-Trimethyl-4- <i>n</i> -tridecane—Phenylisobutylmethane	C ₁₅ H ₁₆	218
Tetraphenylpropadiene—Tetraphenylsilane	C ₁₅ H ₁₆	742	Tri- <i>n</i> -phenylsilane— <i>tert</i> -Butylbenzene	C ₁₅ H ₁₆	488
<i>n</i> -Thulene	C ₁₅ H ₁₆	783	Tri- <i>n</i> -phenylsilane—Benzol[1]phenylene, Isocyclylene	C ₁₅ H ₁₆	783
Thulene—Tetraacetene, Dihydrodibutene	C ₁₅ H ₁₆	387	Triphenyl-1,4-Diphenylbenzene	C ₁₅ H ₁₆	673
Thulene	C ₁₅ H ₁₆	351	Triphenylbenzene—sym-Triphenylbenzene	C ₁₅ H ₁₆	733
Tolan—Diphenylacetylene	C ₁₅ H ₁₆	352	sym-Triphenylbenzene—1,3,5-Triphenylbenzene	C ₁₅ H ₁₆	733
Toluene—Methylbenzene, Phenylmethane	C ₁₅ H ₁₆	498	Triphenylene—Benzol[1]phenylene, Isocyclylene	C ₁₅ H ₁₆	671
<i>n</i> -Tolyltoluene—1-Methyl-3- <i>n</i> -butylbenzene	C ₁₅ H ₁₆	93	1,1,1-Triphenylbenzene—Methyltriphenyl	C ₁₅ H ₁₆	706
1- <i>n</i> -Tolyltoluene—1-Methyl-3- <i>n</i> -butylbenzene	C ₁₅ H ₁₆	502	1,1,2-Triphenylbenzene	C ₁₅ H ₁₆	707
1- <i>n</i> -Tolyltoluene—1-Methyl-4- <i>n</i> -butylbenzene	C ₁₅ H ₁₆	425	Triphenylbenzene—Phenyltoluene	C ₁₅ H ₁₆	689
<i>n</i> -Tricosane	C ₁₅ H ₁₆	426	Triphenylmethane	C ₁₅ H ₁₆	688
Tributylmethane—3-Butylbenzene	C ₁₅ H ₁₆	427	Triphenylmethyl—Triyl	C ₁₅ H ₁₆	687
<i>n</i> -Tricosane— <i>n</i> -Tricosane	C ₁₅ H ₁₆	777	1,1,1-Triphenylpropane—Ethytriphenyl	C ₁₅ H ₁₆	719
Tricyclic—Cyclic	C ₁₅ H ₁₆	495	Tripropylmethane—4-Propylbenzene	C ₁₅ H ₁₆	417
Tridecane—Tridecylene	C ₁₅ H ₁₆	731	Triyl—Triphenylmethane	C ₁₅ H ₁₆	687
Tridecane—Tridecylene	C ₁₅ H ₁₆	355	Triene—1,3,5-Cyclohexatriene	C ₁₅ H ₁₆	609
Tridecane—Tridecylene	C ₁₅ H ₁₆	492			
1,2,4-Trichlorobenzene— <i>n</i> -Triethylbenzene	C ₁₅ H ₁₆	470	<i>n</i> -Undecane— <i>n</i> -Undecene	C ₁₅ H ₁₆	447
1,3,5-Trichlorobenzene—sym-Triethylbenzene	C ₁₅ H ₁₆	471	1-Undecene—1-Undecene	C ₁₅ H ₁₆	444
<i>n</i> -Triethylbenzene—1,2,4-Trichlorobenzene	C ₁₅ H ₁₆	470	2-Undecene—2-Undecene	C ₁₅ H ₁₆	443
sym-Triethylbenzene—1,3,5-Trichlorobenzene	C ₁₅ H ₁₆	471	<i>n</i> -Undecylene—1-Hendecene	C ₁₅ H ₁₆	445
1,2,3-Trichloro-1-cyclopentene	C ₁₅ H ₁₆	442	<i>n</i> -Undecylene—3-Hendecene	C ₁₅ H ₁₆	445
Triethylmethane—3-Ethylpropane	C ₁₅ H ₁₆	148	1-Undecyne—1-Hendecyne	C ₁₅ H ₁₆	445
Triethylmethane—3-Methyl-3-ethylpentane	C ₁₅ H ₁₆	227			
<i>n</i> -Tricosane— <i>n</i> -Tricosane	C ₁₅ H ₁₆	731	Valerylene—3-Pentylene	C ₁₅ H ₁₆	37
Trimethylallene—2-Methyl-2-pentadecene	C ₁₅ H ₁₆	65	Valylene—3-Methyl-3-butyl-1-yne	C ₁₅ H ₁₆	28
1,2,4-Trimethylallene	C ₁₅ H ₁₆	663	Valerylene	C ₁₅ H ₁₆	308
1,3,6-Trimethylallene	C ₁₅ H ₁₆	664	Vinylacetylene—3-Buten-1-yne	C ₁₅ H ₁₆	14
1,4,6-Trimethylallene	C ₁₅ H ₁₆	665	Vinylbenzene—Styrene	C ₁₅ H ₁₆	155
1,2,3-Trimethylbenzene—Hemellitene, Hemellitene, vic-Trimethylbenzene	C ₁₅ H ₁₆	241	<i>n</i> -Vinylcyclohexane—3,3-Diphenyl-1-propylene	C ₁₅ H ₁₆	535
1,2,4-Trimethylbenzene—pseudocumene	C ₁₅ H ₁₆	241	Vinyltoluene—1,3-Butadiene	C ₁₅ H ₁₆	17
<i>n</i> -Trimethylbenzene	C ₁₅ H ₁₆	242	<i>o</i> -Xylene—1,2-Dimethylbenzene	C ₁₅ H ₁₆	158
1,3,5-Trimethylbenzene— <i>m</i> -Xylene, sym-Trimethylbenzene	C ₁₅ H ₁₆	243	<i>m</i> -Xylene—1,3-Dimethylbenzene	C ₁₅ H ₁₆	157
<i>n</i> -Trimethylbenzene—1,2,4-Trimethylbenzene	C ₁₅ H ₁₆	242	<i>p</i> -Xylene—1,4-Dimethylbenzene	C ₁₅ H ₁₆	159
vic-Trimethylbenzene—1,2,3-Trimethylbenzene	C ₁₅ H ₁₆	241			
sym-Trimethylbenzene—1,3,5-Trimethylbenzene	C ₁₅ H ₁₆	243	Zingiberene	C ₁₅ H ₁₆	579

II. TABULATED DATA

The physical properties of pure hydrocarbons have been taken from various sources in the literature and collected in the following table, the source of the data being indicated by a reference number.

In cases where the boiling-points were given at a pressure other than 760 mm they have been corrected to 760 mm by means of the boiling-point conversion chart which will be found in the article on that subject. When the boiling-point was given at a pressure close to 760 mm i.e. above 700 mm the conversion may be regarded as quite accurate and the actual boiling-point as determined has been omitted. In cases where the pressure was far removed from 760 mm the original figure is given for reference as well as the corrected figure.

In cases when the densities have been determined at some temperature other than 20° C these have been corrected to 20° C by means of a simple correlation of the coefficient of expansion of pure hydrocarbons given in the literature, and this correlation is given in another article. In this case the correction to the standard temperature 20° C cannot be

considered to be perfectly accurate, but the probable error is less than about ± 0.0002 , when the correction is applied over only about 4 or 5° C. The density as determined is given for reference as well as the value corrected to 20° C. In some cases the specific gravity with reference to water at a temperature other than 4° C, was determined, in which case this figure is given in the same column with the reference temperature included. For instance, the specific gravity of hydrocarbon Ref no. 45 was determined at 0° C with reference to water at 0° C. The correction to the density to 20° C of such compounds of course takes into account both the change in volume of the water to 4° C and of the hydrocarbon to 20° C.

The refractive indices when determined at other temperatures have been corrected to 20° C and the original figure included as well. This correction was made over the small temperature range required by assuming the specific refraction of Gladstone and Dale $\left(\frac{n-1}{d}\right)$ to be constant, and the change in density d was calculated by the same method used for correcting the density in the previous column.

TABLE I
Melting-point, Boiling-point, Density and Refractive Index of Hydrocarbons

Ref no	Formula	Name	Mol wt	Melting-point, °C	Boiling-point, at 760 mm, °C	Density g/ml		Refractive index	
						at 0° C	at 20° C	n_D^{20}	n_D^{20}
1	H ₂	Hydrogen [10]	2.0154	-259.1 _a	-252.7	0.0709 ¹⁰			
2	C	Carbon (graphite) [10]	12.000	3,500 (subl.)	4,200	2.555 (s)			
3	C	(diamond) [10]	"	"	"	3.51 (s)			
4	CH ₄	Methane [10]	16.031	-182.6	-161.4	0.415 ^{10a}			
5	C ₂ H ₂	Acetylene [13]	26.015	-81.8	-83.6	0.6208 ¹³			
6	C ₂ H ₄	Ethylene [13]	28.03	-169.4	-103.9	0.5699 ^{13a}		1.363 ^{13a}	[7]
7	C ₂ H ₆	Ethane [13]	30.05	-172.0	-88.3	0.5459 ^{13a}			
8	C ₃ H ₄	Propadiene [10]	40.03	-146	-32				
9	"	Propyne [13]	"	-104.7	-27.5	0.6785 ^{13a}			
10	C ₃ H ₆	Cyclopropane [10]	42.05	-126.6	-34.4	0.720 ¹⁰			
11	"	Propylene [13]	"	-183.2	-47.0	0.6095 ^{13a}			
12	C ₃ H ₈	Propane [13]	44.06	-189.9	-44.5	0.5853 ^{13a}			
13	C ₄ H ₆	Butadiene [7]	50.02	-36.4	10.3				
14	C ₄ H ₆	3-Buten-1-yne [7]	52.03		5 ^{7a}	0.6867 ^{7a}	0.6866		
15	C ₄ H ₈	Cyclobutane [8]	54.05		2	0.733 ⁸	0.706		
16	"	1,2-Butadiene [10]	"		19				
17	"	1,3-Butadiene [7]	"	-5	-3	0.650 ^{7a}	0.610		
18	"	1-Butyne [10]	"	-130	18.5	0.668 ¹⁰	0.643		1.3962
19	"	2-Butyne [10]	"		28.9				
20	C ₄ H ₈	Cyclobutane [10]	56.06	-50	13	0.703 ¹⁰	0.678	1.3752 ¹⁰	1.3619
21	"	Methylcyclopropane [10]	"		5	0.691 ¹⁰			
22	"	1-Butylene [10]	"	-130	-6.6 [13]	0.6261 ¹⁰	0.586		1.3962
23	"	2-Butylene [4]	"	-127		0.6289 ⁴	0.604		
a	"	cis [12]			0.3				
b	"	trans [12]			3.0				
24	"	Isobutylene [4]	56.06	-146.8	-6.6	0.6268 ⁴	0.587		
25	C ₄ H ₁₀	n-Butane [4]	58.08	-135	-0.5				
26	"	Isobutane [4]	"	-145	-10.2				

THE PROPERTIES OF PURE HYDROCARBONS

1327

TABLE I (cont.)

Ref no	Formula	Name	Mol wt	Melting-point, °C	Boiling-point, at 760 mm., °C	Density g/ml		Refractive index	
						at t° C	at 20° C	n _D ²⁰	n _D ²⁵
27	C ₅ H ₈	1,3-Cyclopentadiene [10]	66.05		42.5		0.805	1.4470 ¹⁴	1.4449
28	"	3-Methyl-3-buten-1-yne [10]	"		50				
29	C ₅ H ₈	Cyclopentene [8]	68.06	-98.3 [7]	46	0.7743 ¹⁴	0.7722	1.4218 ¹⁴	1.4207
30	"	1,2-Pentadiene [7]	"	"	45				
31	"	1,3-Pentadiene [10]	"	"	44		0.696	1.4402 ¹⁴	1.4382
32	"	1,4-Pentadiene [7]	"	"	25.8		0.6594		1.3880
33	"	2,3-Pentadiene [8]	"	"	31	0.7024 ¹⁴	0.7023		
34	"	3-Methyl-1,3-butadiene [8]	"	-120 [10]	40.5		0.6833		1.4166
35	"	2-Methyl-1,3-butadiene [10]	"	-120	34		0.6808	1.4221 ¹⁴	1.4211
36	"	1-Pentyne [10]	"	-95	40	0.722 ^a	0.703	1.4079 ¹⁴	1.4068
37	"	2-Pentyne [10]	"	-101 [4]	56		0.687		1.4004
38	"	3-Methyl-1-butyne [10]	"	"	29.3	0.685 ^a	0.662		
39	C ₅ H ₈	Cyclopentane [8]	70.08	-93.3 [10]	50		0.7510		1.4039
40	"	Methylcyclobutane [7]	"	"	42		0.694		
41	"	1,1-Dimethylcyclopropane [8]	"	"	21		0.660		1.366
42	"	1,2-Dimethylcyclopropane	"	"					
a	"	(Isomer 1) [8]	"	"	29		0.6769		1.3713
b	"	(Isomer 2) [8]	"	"	37		0.6928		1.3822
43	"	1-Pentene [9]	"	"	30.0				1.3731
44	"	2-Pentene [14]	"	-138 ± 2	36.4		0.6505		1.3808
45	"	2-Methyl-1-butene [10]	"	"	32	0.667 ₇	0.646	1.378 ¹⁴	1.376
46	"	3-Methyl-1-butene [14]	"	-135 [10]	20.1	0.632 ¹⁴	0.627	1.3675 ¹⁴	1.3644
47	"	2-Methyl-2-butene [14]	"	-123 ± 2	38.4	0.6671 ¹⁴	0.6620	1.3908 ¹⁴	1.3878
48	C ₆ H ₁₀	n-Pentane [18]	72.09	-129.93	36.00		0.62632		1.35769
49	"	2-Methylbutane [10]	"	-159.7	28.0		0.6211 ¹⁴		1.355
50	"	2,2-Dimethylpropane [10]	"	-20	9.5	0.613 ₇	0.588		
51	C ₆ H ₆	Benzene [8]	78.046	5.48	80.08	0.8757 ¹⁴	0.8707		1.50165
52	"	1,5-Hexadiene-3-yne [8]	"	"	83.5		0.7851		1.504
53	"	1,5(ox 2,4)-Hexadiyne [10]	"	-6	85.4		0.805	1.4413 ¹⁴	1.4434
54	C ₆ H ₆	1,2-Dihydrobenzene [8]	80.06	-98 [10]	80.5		0.8404		1.4758
55	"	1,4-Dihydrobenzene [8]	"	"	86-7		0.8471		1.4729
56	"	1,3,5-Hexatriene [2]	"	-11	80	0.740 ¹⁴	0.734	1.517 ¹⁴	1.513
57	"	1-Hexen-5-yne [10]	"	"	70	0.858 ¹⁴	0.856		
58	C ₆ H ₁₀	Cyclohexene [10]	82.08	-103.7	83		0.8102	1.4451 ¹⁴	1.4461
59	"	Methylenecyclopentane [2]	"	"	78-81				
60	"	1-Methyl-2-cyclopentene [2]	"	"	69		0.765		1.413
61	"	1-Methyl-3-cyclopentene [2]	"	"	72		0.772		1.427
62	"	1,5-Hexadiene [8]	"	-141	59.6		0.6880 [7]		1.4044
63	"	2,4-Hexadiene [8]	"	"	82 [7]		0.7108		1.4384
64	"	3-Methyl-1,3-pentadiene [2]	"	"	76-9	0.7576 ^a	0.7384	1.4543 ¹⁴	1.4523
65	"	2-Methyl-2,3-pentadiene	"	"	"				
66	"	2,3-Dimethyl-1,3-butadiene [8]	"	-65 [7]	69-70	0.7446 ₁	0.7246		1.4377
67	"	1-Hexyne [10]	"	-150	71.5	0.736 ^a	0.716		
68	"	2-Hexyne [10]	"	"	84	0.749 ^a	0.730		
69	C ₆ H ₁₀	Cyclohexane [10]	84.09	6.5	80.8 [17]		0.7791		1.4273
70	"	Methylcyclopentane [10]	"	-140.5	71.8		0.750		
71	"	Ethylcyclobutane [2]	"	"	72		0.745	1.4080 ¹⁴	1.4078
72	"	1,1,2-Trimethylcyclopropane [2]	"	"	52.8		0.695		1.3866
73	"	1,2,3-Trimethylcyclopropane [2]	"	"	65-6	0.6921 ¹⁴	0.6938	1.3942 ¹⁴	1.3952
74	"	1-Hexene [10]	"	-98.5	64.1		0.683		1.3821
75	"	2-Hexene [7]	"	"	67.9-68.1		0.6813		
76	"	3-Hexene	"	"	"				
a	"	(Isomer 1) [7]	"	"	67.5	0.722 ¹⁴	0.717		
b	"	(Isomer 2) [7]	"	"	70-1	0.693 ₆	0.692		
77	"	2-Methyl-1-pentene [7]	"	"	61.5-62.0		0.6817		
78	"	3-Methyl-1-pentene [7]	"	"	53.6-54.0		0.6700		

TABLE I (cont.)

Ref no	Formula	Name	Mol wt	Melting-point, °C	Boiling-point, at 760 mm., °C	Density g/ml		Refractive index	
						at t° C	at 20° C	n _D ²⁰	n _D ²⁰
79	C ₅ H ₁₂	4-Methyl-1-pentene [7]	84.09		53.6-53.9		0.6646		
80	"	2-Methyl-2-pentene [10]	"		67.1		0.692	1.4013 ¹⁸	1.3991
81	"	3-Methyl-2-pentene	"						
a	"	(Isomer 1) [7]	"		67.6-68.2		0.6936	1.4065 ¹⁸ [10]	1.4038 [10]
b	"	(Isomer 2) [7]	"		65.7-66.2		0.6940		1.401 [10]
82	"	4-Methyl-2-pentene	"						
a	"	(Isomer 1) [7]	"		57.7-58.5		0.6709		
b	"	(Isomer 2) [7]	"		54.2-55.2		0.6702		
83	"	2-Ethyl-1-butene [7]	"		66.2-66.7		0.6914		
84	"	2,3-Dimethyl-1-butene [8]	"		56		0.6803		1.3995
85	"	3,3-Dimethyl-1-butene [8]	"		41.2	0.6549 ¹⁸	0.6529		1.3767
86	"	2,3-Dimethyl-2-butene [8]	"		73		0.728		1.4128
87	C ₆ H ₁₄	n-Hexane [18]	86.11	-95.39	68.71		0.65945		1.37506
88	"	2-Methylpentane [5]	"		60.2		0.6542	1.37445 ¹⁸	1.37186
89	"	3-Methylpentane [5]	"		63.2		0.6647	1.37929 ¹⁸	1.37667
90	"	2,2-Dimethylbutane [5]	"	-98.2 [10]	49.7		0.6498	1.37158 ¹⁸	1.36882
91	"	2,3-Dimethylbutane [5]	"	-135.1 [10]	58.1		0.6618	1.38092 ¹⁸	1.37827
92	C ₇ H ₁₄	1,3,5-Cycloheptatriene [10]	92.06		118		0.888		1.5261
93	"	Toluene [10]	"	-95.1	110.5		0.8658		1.4962
94	C ₇ H ₁₄	1,3-Cycloheptadiene [8]	94.08		122 (121 ¹⁹)	0.8929 ¹⁸	0.8746		
95	"	1,2-Dihydrotoluene [7]	"		110.1		0.8354		1.4763
96	"	1,3,5-Heptatriene [10]	"		114		0.764		
97	C ₇ H ₁₄	Cycloheptene [8]	96.09		115		0.8228		1.4552
98	"	Methylenecyclohexane [2]	"		102	0.8072 ¹⁸	0.8021		1.4534
99	"	Methyl-1-cyclohexene [10]	"		111		0.809		1.4496
100	"	Methyl-2-cyclohexene [10]	"		105		0.805		1.4454
101	"	Methyl-3-cyclohexene [10]	"		103		0.799		1.443
102	"	Ethylidenecyclopentane [2]	"		114				
103	"	1-Ethyl-1-cyclopentene [2]	"		108		0.796		1.443
104	"	Methyl-3-methylenecyclopentane [2]	"		93	0.7734 ¹⁸	0.7726		
105	"	1,2-Dimethyl-1-cyclopentene [2]	"		103		0.794		1.442
106	"	1,1-Dimethyl-2-cyclopentene [2]	"		78		0.7580		1.4190
107	"	2,4-Heptadiene [10]	"		107		0.731	1.4554 ¹⁸	1.4534
108	"	3-Methyl-1,3-hexadiene [2]	"		101-3	0.7404 ¹⁸	0.7448	1.4525 ¹⁸	1.4552
109	"	3-Methyl-2,4-hexadiene [2]	"		107-8	0.7753 [*]	0.7575	1.4615 ¹⁸	1.4588
110	"	2,4-Dimethyl-1,3-pentadiene [8]	"		93		0.7368		1.4412
111	"	2,4-Dimethyl-2,3-pentadiene [10]	"		70				
112	"	1-Heptyne [10]	"	> -70	110.5	0.738 ¹⁸	0.732		1.406
113	"	2-Heptyne [10]	"		113.3	0.763 [*]	0.745		
114	"	3-Heptyne [10]	"		106	0.760 [*]	0.742		
115	C ₇ H ₁₄	Cycloheptane [8]	98.11	-12 [10]	118.1 [17]		0.8099		1.4440
116	"	Methylcyclohexane [10]	"	-126.3	100.8 [17]	0.7864 [*]	0.7700		1.4235
117	"	Ethylcyclopentane [17]	"		103.0				
118	"	1,1-Dimethylcyclopentane [8]	"		87.5 [17]	0.7552 ¹⁸	0.7551		1.4139
119	"	1,2-Dimethylcyclopentane [8]	"		91.8 [17]	0.7534 ¹⁸	0.7533		1.4126
120	"	1,3-Dimethylcyclopentane	"						
a	"	d [8]	"		91	0.7497 ¹⁸	0.7480	1.4110 ¹⁸	1.4101
b	"	d [8]	"		91.5	0.7563 ¹⁸	0.7562		1.4144
121	"	1-Methyl-2-isopropylcyclopropane [2]	"		80-1	0.7120 ¹⁸	0.7119		1.3927
122	"	1-Heptene [7]	"	-10	94.9		0.6993		
123	"	2-Heptene [7]	"		98.1-98.4		0.7034		
124	"	3-Heptene [7]	"		95.8-96.1		0.7043		
125	"	2-Methyl-1-hexene [7]	"		91.1-91.5		0.7000		

THE PROPERTIES OF PURE HYDROCARBONS

1329

TABLE I (cont)

Ref no	Formula	Name	Mol wt	Melting-point, °C	Boiling-point, at 760 mm, °C	Density g/ml		Refractive index	
						at 1° C	at 20° C	n_D^{20}	n_D^{25}
126	C ₆ H ₁₄	3-Methyl-1-hexene [7]	98 11		84 0		0 6953		
127	"	4-Methyl-1-hexene [7]	"		87 2-87 5		0 6969		
128	"	5-Methyl-1-hexene [7]	"		84 7		0 6935		
129	"	2-Methyl-2-hexene [7]	"		94 4-94 6		0 7089		
130	"	3-Methyl-2-hexene [7]	"		93 1-93 3		0 7120		
131	"	4-Methyl-2-hexene	"						
a	"	(Isomer 1) [7]	"		87 1-87 6		0 7007		
b	"	(Isomer 2) [7]	"		85 1-85 6		0 6981		
132	"	5-Methyl-2-hexene	"						
a	"	(Isomer 1) [7]	"		91 1-91 6		0 6990		
b	"	(Isomer 2) [7]	"		85 6-86 1		0 7020		
133	"	2-Methyl-3-hexene [7]	"		86 4-86 9		0 6942		
134	"	2,3-Dimethyl-1-pentene	"		84 1-84 3		0 7054		
	"	[7]	"						
135	"	2,4-Dimethyl-1-pentene	"		80 9-81 3		0 6937		
	"	[7]	"						
136	"	3,3-Dimethyl-1-pentene	"		76 9		0 6961	1 3991	
	"	[7]	"						
137	"	2-Ethyl-1-pentene [7]	"		93 9-94 3		0 7079		
138	"	2,3-Dimethyl-2-pentene	"		95 1		0 719		
	"	[10]	"						
139	"	2,4-Dimethyl-2-pentene	"		82 6		0 6947	1 4020	
	"	[8]	"						
140	"	3,4-Dimethyl-2-pentene	"		86 2-86 4		0 7126	1 4052	
	"	[7]	"						
141	"	4,4-Dimethyl-2-pentene [7]	"		76 0		0 6881	1 3986	
142	"	3-Ethyl-2-pentene [7]	"		94 8-94 9		0 7172		
143	"	2,3,3-Trimethyl-1-butene	"		80	0 707 ^a [1]	0 707		
	"	[10]	"						
144	"	3-Methyl-2-ethyl-1-butene	"		88 7-89 1		0 7186		
	"	[7]	"						
145	C ₇ H ₁₆	n-Heptane [18]	100 12	-90 65	98 38		0 68378	1 38775	
146	"	2-Methylhexane [5]	"	-119 1	90 0		0 6789	1 38509	
147	"	3-Methylhexane [5]	"		91 8		0 6870	1 38873	
148	"	3-Ethylpentane [5]	"		93 3		0 6984	1 39366	
149	"	2,2-Dimethylpentane [5]	"	-125 6	78 9		0 6737	1 38233	
150	"	2,3-Dimethylpentane [5]	"		89 7		0 6952	1 39201	
151	"	2,4-Dimethylpentane [5]	"	-123 4	80 8		0 6745	1 38233	
152	"	3,3-Dimethylpentane [5]	"	-135 0	86 0		0 6934	1 39114	
153	"	2,2,3-Trimethylbutane [5]	"	-25 0	80 9		0 6900	1 38940	
154	C ₈ H ₈	Ethynylbenzene [7]	102 05	-40 to -48	143		0 9295	1 5524 ¹¹ *	1 5483
155	C ₈ H ₈	Styrene [7]	104 06		146		0 9074	1 5434 ¹¹	1 5418
156	C ₈ H ₁₀	Ethylbenzene [7]	106 08	-93 9	136 1 [17]		0 8669	1 4983 ¹¹ *	1 4958
157	"	o-Xylene [7]	"	-29	144 4 [17]		0 8745	1 5078 ¹¹ *	1 5056
158	"	m-Xylene [7]	"	-53 6	139 2 [17]		0 8641	1 4996 ¹² **	1 49707
159	"	p-Xylene [7]	"	15-16	138 4 [17]		0 8612	1 49734 ¹¹ **	1 49545
160	"	Dimethylfulvene	"						
162	C ₈ H ₁₆	1,3-Dimethyl-1,3-cyclohexadiene [8]	108 09		135-6		0 8373		1 4856
163	"	1,4-Dimethyl-1,3-cyclohexadiene [10]	"		135 6		0 830		1 4792
164	"	1,5-Dimethyl-1,3-cyclohexadiene [8]	"		127-32		0 821		1 471
165	"	2,3-Dimethyl-1,3-cyclohexadiene [8]	"		135 2		0 8521		1 4895
166	"	2,5-Dimethyl-3-cyclohexadiene [8]	"		133		0 8223		1 4675
167	"	2,6-Dimethyl-1,3-cyclohexadiene [10]	"		130		0 823		1 4675
168	"	5,5-Dimethyl-1,3-cyclohexadiene [8]	"		111	0 8157 ¹¹	0 8111		
169	C ₈ H ₁₆	Ethylidenecyclohexane [2]	110 11		137-8		0 823		

TABLE I (cont)

Ref. no	Formula	Name	Mol wt	Melting-point, °C	Boiling-point, at 760 mm., °C	Density g/ml		Refractive index	
						at t° C	at 20° C	n _D ²⁰	n _D ²⁰
170	C ₈ H ₁₆	1-Methyl-3-methylene-cyclohexane [2]	110.11		123-4		0.798		
171	"	1-Methyl-4-methylene-cyclohexane [2]	"		122		0.792		1.445
172	"	1,2-Dimethyl-1-cyclohexene [8]	"		135-6	0.8260 ₁₁	0.8253		1.4590
173	"	1,3-Dimethyl-1-cyclohexene [8]	"		124-6		0.8006		1.4487
174	"	1,4-Dimethyl-1-cyclohexene [8]	"		124-6		0.8005		1.4457
175	"	1,5-Dimethyl-1-cyclohexene	"						
a		d [8]	"		126-7	0.8015 ^m	0.8031	1.4466 ^m	1.4475
b		dl [8]	"		124	0.8122 ^m	0.8059	1.451 ^m	1.447
176	"	3,4-Dimethyl-1-cyclohexene [2]	"		124		0.807		1.444
177	"	3,5-Dimethyl-1-cyclohexene [10]	"		124		0.801		1.444
178	"	4,4-Dimethyl-1-cyclohexene [8]	"		120-1	0.8056 ¹¹	0.8024	1.445 ¹¹	1.443
179	"	Isopropylidenecyclopentane [2]	"		136-7		0.817		
180	"	Lauroleone [20]	"		120	0.8048 ₁₁	0.7966		1.4438
181	"	Isolauroleone [20]	"		108.5	0.7867 ₁₁	0.7819		1.4333
182	"	1-Octyne [10]	"		125	0.770 ^a	0.753	1.4208 ¹¹	1.4171
183	"	2-Octyne [10]	"		134				
184	"	1,4-Octadiene [16]	"		127 (126 ^m)	0.770 ^a	0.753		
185	"	3-Methyl-2,4-heptadiene [2]	"		132-5	0.7783 ^a	0.7618	1.4693 ¹¹	1.4667
186	"	6-Methyl-2,4-heptadiene [2]	"		114-16	0.7516 ^a	0.7348	1.4397 ^m	1.4422
187	"	2,5-Dimethyl-1,3-hexadiene [8]	"	> -80	116-18		0.7412		1.4502
188	"	2,5-Dimethyl-1,5-hexadiene [8]	"		115-17	0.7487 ₁₁	0.7482	1.4399 ¹¹	1.4404
189	"	2,5-Dimethyl-2,3-hexadiene [8]	"	< -80	119-23		0.7637		1.4505
190	"	2,5-Dimethyl-2,4-hexadiene [8]	"	> -23 6	134.6	0.7646 ¹¹	0.7630	1.4796 ¹¹	1.4794
191	"	3,4-Dimethyl-2,4-hexadiene [8]	"		132-4	0.7832 ¹¹	0.7824	1.4630 ^m	1.4655
192	"	3,5-Dimethyl-2,4-hexadiene [8]	"		114-15	0.7635 ¹¹	0.7605	1.4546 ¹¹	1.4528
193	C ₈ H ₁₆	Cyclooctane [8]	112.12	14.3	148-9		0.8349		1.4586
194	"	Ethylcyclohexane	"		131.9 [17]		0.7772 [2]		
195	"	1,1-Dimethylcyclohexane [8]	"		120	0.7864 ₁₁	0.7818	1.4314 ^a	1.4293
196	"	1,2-Dimethylcyclohexane cis [8]	"	-25	130		0.7822		
b		trans [8]	"	-90	124		0.7798		
197	"	1,3-Dimethylcyclohexane cis [8]	"	-85 [10]	120.0 [17]		0.7735		1.4269
a		trans [8]	"		121		0.772		1.4254
b			"		119				1.421
198	"	1,4-Dimethylcyclohexane [10]	"	-86	121.7 [17]				
a		cis [8]	"		120.5		0.7671		
b		trans [8]	"		119		0.7658		
199	"	n-Propylcyclopentane [17]	"		131.3				
200	"	1-Methyl-2-ethylcyclopentane [17]	"		124.0				
201	"	1-Methyl-3-ethylcyclopentane [2]	"		120.5-121.0	0.7669 ¹¹	0.7639		
202	"	1,1,2-Trimethylcyclopentane [2]	"		113.0-113.5	0.7847 ¹¹	0.7722		
203	"	1,2,4-Trimethylcyclopentane [17]	"		112.5-113.0				

THE PROPERTIES OF PURE HYDROCARBONS

1331

TABLE I (cont)

Ref no	Formula	Name	Mol wt	Melting-point, °C	Boiling-point, at 760 mm., °C	Density g/ml		Refractive index	
						at 1° C	at 20° C	n_D^{20}	n_D^{25}
204	C ₈ H ₁₈	1-Methyl-2-isobutylcyclopropane [2]	112.12		110-11		0.7403		
205	"	1-Methyl-1,2-diethylcyclopropane [2]	"		108-9	0.7382 ^a	0.7381		1.4102
206	"	Octene [7]	"		123		0.7155		1.4087
207	"	6-Methyl-1-heptene [2]	"		111-12		0.7124		
208	"	2-Methyl-2-heptene [10]	"		125.2		0.816		
209	"	2-Methyl-3-heptene [2]	"		120.4		0.7314		
210	"	4-Methyl-3-heptene [10]	"		120.4		0.724		1.415
211	"	2,5-Dimethyl-3-hexene [7]	"		116-20				
212	"	3-Ethylhexene [2]	"		119.4		0.7364		
213	"	2-Methyl-3-ethyl-2-pentene [10]	"		117.1				
214	"	2,4,4-Trimethyl-1(or 2)-pentene [7]	"		102.6	0.715 ^a	0.711		
215	C ₈ H ₁₈	n-Octane [18]	114.14	-56.90	125.59		0.70279		1.39760
216	"	2-Methylheptane [7]	"		117.2 [17]		0.7029		1.3935
217	"	3-Methylheptane [17]	"		117.6		0.707 [10]		
218	"	4-Methylheptane [10]	"		118.0		0.722		1.398
219	"	3-Ethylhexane [7]	"		118.9		0.7169		1.4016
220	"	2,2-Dimethylhexane [8]	"		106-7		0.6967		1.391
221	"	2,3-Dimethylhexane [7]	"		113.9		0.7240		1.4093
222	"	2,4-Dimethylhexane [5]	"		109.9		0.703		1.4026
a	"	d [8]	"		111-12	0.696 ^a	0.704		
b	"	i [8]	"		110-11	0.703 ^a	0.704		
c	"	di [8]	"		110	0.7083[1]	0.7036	1.3986 ^a	1.4009
223	"	2,5-Dimethylhexane [7]	"	-91.0	108.25		0.6985		1.3929
224	"	3,3-Dimethylhexane [8]	"		111-12		0.7116		1.3998
225	"	3,4-Dimethylhexane [10]	"		116.5		0.721		1.4058
226	"	2-Methyl-3-ethylpentane [10]	"		114.0	0.708 ^a	0.704		1.4016
227	"	3-Methyl-3-ethylpentane [7]	"		119.0		0.712		
228	"	2,2,3-Trimethylpentane [7]	"		110.7		0.7213		1.403
228.1	"	2,2,4-Trimethylpentane [5]	"		99.3		0.6918		1.3916
229	"	2,2,3,3-Tetramethylbutane [7]	"	104	106.8				
230	C ₉ H ₁₀	Indene [10]	116.06	-2	182.4		1.006	1.571 ^a	1.577
231	"	(1-Propenyl)benzene [10]	"		185				
232	C ₉ H ₁₀	Hydrindene [10]	118.08		176.5		0.965	1.5370 ^a	1.5377
233	"	(1-Propenyl)benzene [4]	"		175		0.914		
234	"	(2-Propenyl)benzene [10]	"		155		0.909		1.5143
235	"	Isopropenylbenzene [7]	"		160.5-161.5		0.9139		
236	C ₉ H ₁₀	n-Propylbenzene [7]	120.09	-101.6	159.45		0.862	1.49549 ^a	1.49185
237	"	Isopropylbenzene [7]	"	-96.9	152-3		0.864	1.4947 ^a	1.4923
238	"	1-Methyl-2-ethylbenzene [7]	"	< -17	162		0.873	1.50569 ^a	1.50378
239	"	1-Methyl-3-ethylbenzene [7]	"		162.5		0.869	1.49966 ^a	1.49961
240	"	1-Methyl-4-ethylbenzene [7]	"	< -20	162		0.862	1.49303 ^a	1.49433
241	"	1,2,3-Trimethylbenzene [10]	"	< -15 [7]	176.1 [17]		0.895		1.5132
242	"	1,2,4-Trimethylbenzene [10]	"	-61.0	169.2 [17]	0.8888 ^a [8]	0.8758		1.5051
243	"	1,3,5-Trimethylbenzene [10]	"	-52.7	164.64 [17]		0.8634		1.4967
244	C ₁₀ H ₁₆	Apobornylene [20]	122.11	35.5-36.0	136-7				
245	"	Apocycloene [20]	"	42.5-43.0	138-9	0.8710 ^a	0.8877	1.43144 ^a	1.43971
246	"	Camphenylene [8]	"	27-8	140-1	0.8693 ^a	0.8710	1.4686 ^a	1.4695
247	"	1,2,4-Trimethyl-2,5-dihydrobenzene [20]	"						
248	"	Bantene [20]	"		140-1		0.863		1.46658

TABLE I (cont)

Ref no	Formula	Name	Mol wt	Melting-point, °C	Boiling-point, at 760 mm., °C	Density g/ml		Refractive index	
						at t° C	at 20° C	n _D ²⁰	n _D ³⁰
249	C ₈ H ₁₆	Propylidenecyclohexane [2]	124.12		157-8		0.821		
250	"	Isopropylidenecyclohexane [2]	"		160-1		0.836		
251	"	1-Methyl-3-ethylidenecyclohexane [2]	"		153		0.813		
252	"	1-Methyl-4-ethylidenecyclohexane [2]	"		156		0.8125		
253	"	1,3,5-Trimethyl-1-cyclohexene [2]	"		140.5-142	0.8025 ¹¹	0.7983		1.4491
254	"	1,4,5-Trimethyl-1-cyclohexene [2]	"		145		0.805		1.448
255	"	Nopinane [10]	"		149.5	0.861 ¹¹	0.861		1.4614
256	"	Camphenilane [20]	"	15-16	142.5		0.8547		1.4555
257	"	Santane [20]	"		150-2	0.8712 ¹¹	0.8700	1.4636 ¹¹	1.4630
258	"	Apofenchene [20]	"		143				
259	"	Pulegone [10]	"		159	0.791 ¹¹	0.792	1.4380 ¹¹	1.4388
260	"	1,2-Diethyl-1-cyclopentene [2]	"		151.5		0.812		1.452
261	"	1,3-Dimethyl-2-ethyl-1-cyclopentene [2]	"		140		0.803	1.447 ¹¹	
262	"	1,1-Diethyl-2-cyclopentene [2]	"		144		0.808		1.446
263	"	Campholene [20]	"	> -20 [10]	134		0.8034		1.4466
264	"	1,1-Dimethyl-2-(1-isobutyl)-cyclopropane [2]	"		132	0.7677 ¹¹	0.7676		1.442
265	"	1-Nonane [7]	"	-36	160		0.7924		
266	"	7-Methyl-2,4-octadiene [2]	"		149	0.7653 ¹¹	0.7499		
267	"	4-Methyl-3,5-octadiene [2]	"		148-51	0.7640 ¹¹	0.7679		1.4628
268	"	2,6-Dimethyl-1,3-heptadiene [8]	"		140-2	0.7648 ¹¹	0.7567	1.46202 ¹¹	1.45715
269	"	2,6-Dimethyl-1,5-heptadiene [8]	"	-70	140-2	0.7750 ¹¹	0.7676	1.4407 ¹¹	1.4365
270	"	2,6-Dimethyl-2,4-heptadiene [8]	"		139-43	0.7482 ¹¹	0.7481		
271	"	3,5-Dimethyl-2,4-heptadiene [8]	"		144-6	0.7853 ¹¹	0.7692	1.4633 ¹¹	1.4604
272	C ₉ H ₁₈	Cyclononane [8]	126.14		170-2	0.773 ¹¹	0.770	1.4328 ¹¹	1.4313
273	"	Ethylcycloheptane [10]	"	< -30	199		0.767		
274	"	n-Propylcyclohexane [10]	"		149.5		0.787		
275	"	Isopropylcyclohexane [10]	"		150		0.787		
276	"	1-Methyl-2-ethylcyclohexane [2]	"		151		0.784		
277	"	1-Methyl-3-ethylcyclohexane [2]	"		145-6		0.8320		
278	"	1,1,3-Trimethylcyclohexane [2]	"		138		0.790		1.436
279	"	1,2,3-Trimethylcyclohexane [2]	"		149-50				
280	"	1,2,4-Trimethylcyclohexane [2]	"		143-4 [17]		0.778		1.429
281	"	1,3,5-Trimethylcyclohexane [2]	"		137-9 [17]		0.772		1.429
282	"	1-Methyl-2-isopropylcyclopentane [2]	"		142.5	0.7833 ¹¹	0.7796		
283	"	1-Methyl-3-isopropylcyclopentane [2]	"		132-4	0.773 ¹¹	0.772		
284	"	1-Nonene [1]	"		139.5	0.743 ¹¹	0.743		
285	"	2(or 3)-Nonene [10]	"		149.9	0.754 ¹¹	0.749		
286	"	2-Methyl-1-octene [2]	"		141.5-143.0				
287	C ₉ H ₁₈	n-Nonane [18]	128.15	-53.68	150.71		0.71780		1.40563
288	"	2-Methyloctane [17]	"		142.8				
289	"	4,3-Methyloctane [17]	"		143-4	0.7206 ¹¹ [7]	0.7183		

THE PROPERTIES OF PURE HYDROCARBONS

1333

TABLE I (cont.)

Ref no	Formula	Name	Mol wt	Melting-point, °C	Boiling-point, at 760 mm., °C	Density g/ml		Refractive index	
						at 1° C	at 20° C	n_D^{20}	n_D^{25}
290	C ₈ H ₁₈	4-Methyloctane [10]	128 15		141 6	0 732 ₁	0 727		1 4047
291	"	2,4-Dimethylheptane [10]	"		133 5 [17]		0 716		1 404
292	"	2,5-Dimethylheptane	"						
a	"	d [10]	"		137	0 715 ^{1a}	0 712		
b	"	dl [10]	"		135 9	0 719 ₁ ^{1a}	0 714		1 4040
293	"	2,6-Dimethylheptane [10]	"		132 0	0 712 ₁ ^{1a}	0 707		
294	"	4-Ethylheptane [10]	"		139 0		0 717		1 408
295	"	2,2,5-Trimethylhexane [5]	"		126 0		0 707		
295 1	"	3,3-Diethylpentane [8]	"		139 2		0 7522		
296	C ₁₂ H ₂₂	1,2-Diethylnaphthalene [8]	126 05		195 (82 ^{1a})	0 9788 ^{1a}	0 9766	1 5915 ^{1a}	1 5902
297	"	1,3-Diethylnaphthalene [8]	"		190 (78 ^{1a})	0 9669 ^{1a}	0 9652	1 5841 ^{1a}	1 5831
298	C ₁₂ H ₁₂	Naphthalene [7]	128 06		217 9		1 145	1 58218 ^{1a}	
299	C ₁₂ H ₁₂	1,2-Dihydronaphthalene [8]	130 08	-8 to -7	203 (84-5 ^{1a})		0 9974	1 58317 ^{1a}	1 58225
300	"	1,4-Dihydronaphthalene [8]	"	24 5-25	207 (94-5 ^{1a})	0 9928 ^{1a}	0 9937	1 55489 ^{1a}	1 56100
301	"	(1-Butyl)benzene [10]	"		203		0 923		
302	"	(2-Butyl)benzene [10]	"		190				
303	"	1,2-Diethylnaphthalene [8]	"		190 (78-5 ^{1a})	0 934 ^{1a}	0 935	1 5760 ^{1a}	1 5765
304	"	1,3-Diethylnaphthalene [8]	"		195 (52 ^{1a})	0 926 ^{1a}	0 928	1 5746 ^{1a}	1 5756
305	C ₁₄ H ₁₈	1,2,3,4-Tetrahydronaphthalene [10]	132 09		207 2		0 971	1 5451 ^{1a}	1 5442
306	"	(1-Methyl-1-propenyl)benzene [10]	"		189	0 901 ^{1a}	0 902	1 5390 ^{1a}	1 5395
307	C ₁₂ H ₁₈	Hexahydronaphthalene [10]	134 11		205 5		0 934		
308	"	Verbenzene [20]	"		159-60		0 8822		1 49855
309	"	Camphulene [20]	"	41 5-42	149-50				
310	"	n-Butylbenzene [10]	"	-81 2 [7]	180		0 862		1 4914
311	"	Isobutylbenzene [10]	"		171 4		0 857 ^{1a} [7]		1 493
312	"	sec-Butylbenzene [7]	"	-82 7	173 5	0 8634 ^{1a}	0 8644	1 4894 ^{1a}	1 4899
313	"	tert-Butylbenzene [7]	"	-58 1	168 7		0 867	1 49724 ^{1a}	1 49632
314	"	o-Cymene [7]	"	-73 5	175		0 876	1 5003 [10]	
315	"	m-Cymene [7]	"	< -25	175 7		0 8696	1 4925 [10]	
316	"	p-Cymene [8]	"	-72	177		0 8510		1 4904
317	"	o-Propyltoluene [7]	"		181-2			1 50139 ^{1a}	1 49948
318	"	m-Propyltoluene [7]	"		176-7	0 863 ^{1a}	0 860	1 49640 ^{1a}	1 49504
319	"	p-Propyltoluene [7]	"		181-4	0 8682 ^{1a}	0 8643	1 49655 ^{1a}	1 49601
320	"	1,2-Diethylbenzene [10]	"	< -20	184 5	0 8662 ^{1a} [8]	0 8646		
321	"	1,3-Diethylbenzene [8]	"	< -20 [10]	182 [10]		0 8602		1 4955
322	"	1,4-Diethylbenzene [10]	"	< -35	183		0 865		1 495
323	"	1,4-Dimethyl-2-ethylbenzene [7]	"	< -20	185	0 875 ^{1a}	0 877		
324	"	1,2-Dimethyl-4-ethylbenzene [7]	"	< -20	189		0 869		
325	"	1,3-Dimethyl-4-ethylbenzene [7]	"	< -20	185-6		0 8686		
326	"	1,3-Dimethyl-5-ethylbenzene [10]	"	< -20	185		0 861		
327	"	1,2,3,4-Tetramethylbenzene [10]	"	-4	204		0 901		1 5187
328	"	1,2,3,5-Tetramethylbenzene [7]	"	-24	197	0 896 ^{1a}	0 880		
329	"	1,2,4,5-Tetramethylbenzene [10]	"	80	195	0 838 ^{1a}		1 615 _g (solid-biaxial)	
330	C ₁₅ H ₁₈	Camphulene [10]	136 12		156	0 87 ^{1a}	0 87		
331	"	Cryptotene [19]	"		178 (67-8 ^{1a})	0 8128 ^{1a}	0 8162	1 47476 ^{1a}	1 47675
332	"	Geraniene [10]	"		164		0 843		
333	"	Terpenylene [10]	"		175				
334	"	β-Octalin	"						
a	"	cis [10]	"		184 (73 ^{1a})		0 915	1 4959 ^{1a}	1 4969
b	"	trans [10]	"		190	0 909 ^{1a}	0 903		

k k

TABLE I (cont)

Ref no	Formula	Name	Mol wt	Melting-point, °C	Boiling-point, at 760 mm., °C	Density g/ml		Refractive index	
						at 1° C	at 20° C	n _D ²⁰	n _D ²⁵
335	C ₁₅ H ₁₂	α -Pinene							
a		d [20]	136.12	-50	156	0.8620 ¹⁹	0.8581	1.4650 ²⁰	1.4616
b		l [20]	"	-50	156	0.8620 ¹⁹	0.8581	1.4649 ²⁰	1.4615
c		dl [20]	"		155-6	0.858	0.858	1.4655 ²⁰	1.46596
336	"	β -Pinene [20]	"	-75	162-3	0.874 ¹³	0.870	1.4872 ¹⁴	1.4850
337	"	d- Δ^2 -Carene [20]	"		170	0.8668 ¹¹	0.8621	1.4673 ¹²	1.4696
338	"	d- Δ^2 -Carene [20]	"		170	0.8552 ¹¹	0.8589	1.474 ¹²	1.478
339	"	Sylvestrene			(165.6-167 ¹⁷)				
a		d [19]	"		175-8	0.8485 ¹⁴	0.8471		1.4572
b		l [19]	"		176-8	0.848 ¹⁴	0.847		1.4761
c		dl [19]	"		175	0.8479 ¹⁴	0.8464		1.4760
340	"	Δ^1 ¹⁰ , m-Menthadiene [2]	"		182	0.8624 ¹⁵	0.8617		1.5030
341	"	Δ^2 ¹⁰ , m-Menthadiene [2]	"		181-2	0.8609	0.8609		1.4975
342	"	α -Terpinene [19]	"		175		0.834		1.4784
143	"	β -Terpinene [19]	"		(65.4-66 ¹⁸)	0.838 ¹⁸	0.839	1.4754 ¹⁸	1.4762
344	"	γ -Terpinene [19]	"		173-4	0.853 ¹⁸	0.849	1.4754 ¹⁸	1.4737
345	"	l- α -Phellandrene [19]	"		165 (58-91 ¹⁹)		0.8410		1.4732
346	"	β -Phellandrene [19]	"		171-2		0.8520		1.4788
347	"	Perpinolene [7]	"		185		0.855		1.4823
348	"	Limonene							
a		d [19]	"	-96.9 [7]	176-176.4		0.8411	1.4748 ¹⁴ [7]	1.47278
b		l [19]	"		176-176.4		0.8422		1.47443
c		dl [19]	"		175.5-176.5	0.8402 ¹⁸ **	0.8408		1.47043
349	"	Isolimonene [19]	"		172.5-173.5		0.8370		1.47043
350	"	Δ^1 ¹⁰ , p-Menthadiene [2]	"		184-5		0.8580		1.4924
151	"	α -Thujene [20]	"		151		0.8301		1.45155
352	"	β -Thujene [20]	"		148 (147 ²⁰)		0.8208		1.44708
353	"	Sabinene							
a		d [20]	"		163-5		0.842		1.465
b		l [20]	"		163-165	0.8407 ¹¹	0.8443	1.465 ¹¹	1.469
c		dl [10]	"		(161.5-163 ¹⁰)				
354	"	Cyclofenchene [20]	"		165		0.842	1.4674 ¹¹	1.4662
355	"	Tricyclene [20]	"	67.5-68	143-143.5	0.8624 ¹¹ *	0.8596	1.45370 ¹¹ *	1.45211
356	"	Isotricyclene [20]	"	117	150-1	0.8440 ¹¹		1.44055 ¹¹ *	
357	"	Bornylene							
a		d [20]	"		146				
b		l [20]	"	113					
358	"	Camphene							
a		d [20]	"						
b		l [20]	"						
c		dl [20]	"	51-2	158.15-159.5	0.84224 ⁴		4.15514 ⁴	1.4662
359	"	Endocamphene [20]	"		170.6-171.6	0.8957 ¹¹ *	0.8899	1.48442 ¹¹ *	1.48131
360	"	α -Fenchene							
a		d [20]	"						
b		l [20]	"		156-7	0.869 ¹³	0.868	1.4724 ¹⁴	1.4720
c		dl [20]	"		154-6		0.8660		1.47045
361	"	d- β -Fenchene [20]	"		150-3		0.8591	1.4645 ¹⁴	1.4639
362	"	γ -Fenchene [20] (impure)	"		145-7		0.8547		1.46072
363	"	l- β -Fenchene [20] (impure)	"		139-40		0.8381		1.4494
364	"	Cyclopentyl-1-cyclopropene [2]	"		197-8				
365	"	1,2-Diisopropylidene-cyclobutane [2]	"		179-81		0.8422	1.5008 ¹⁴	1.5007
366	"	1,1-Dimethyl-2-methylene-3-isopropylidene-cyclobutane [2]	"		149-50		0.7982		
367	"	1,1,3,3-Tetramethyl-2,4-dimethylenecyclobutane [2]	"		152 (37-8 ⁹)				
368	"	Myrcene [19]	"		166-8	0.8013 ¹⁴	0.7979	1.4700 ¹⁴	1.4696
369	"	Ocimene [19]	"		177 (81 ¹⁹)	0.8031 ¹⁴	0.7997	1.4857 ¹⁴	1.4849
370	"	Allo-ocimene [19]	"		198 (81 ¹⁹)	0.8172 ¹⁴	0.8146	1.5296 ¹⁴	1.5279
371	C ₁₀ H ₁₆	Decahydronaphthalene	138.14						
a		cis [8]	"	-125 [10]	193	0.8953	0.8689	1.46994 ¹¹	1.4675
b		trans [8]	"		185	0.8703 ¹¹	0.8689	1.46994 ¹¹	1.46914

THE PROPERTIES OF PURE HYDROCARBONS

1335

TABLE I (cont)

Ref no	Formula	Name	Mol wt	Melting-point, °C	Boiling-point, at 760 mm., °C	Density g/ml		Refractive index						
						at 1° C	at 20° C	n_D^{20}	n_D^{25}					
372	C ₁₂ H ₂₂	Pinane	138.14		165-6	0.8566		1.4624						
a		cis-d [20]			(163-164 ^{mp})									
b		cis-f [20]			167-168(164.8-165.8 ^{mp})									
c	trans-f [20]			164-166	0.8519 ^{1*}	0.8501	1.45952 ^{1*}	1.45853						
373	"	Carane [20]	"	"	169.5	0.8411 ^{2*}	0.8410	1.4567						
a		d [20]												
b		f [20]												
374	"	Cyclodihydromycene (mixture) [19]	"	"	169-72		0.828	1.462						
375	"	Methyl-3-propylidene-cyclohexane [2]	"	"	170-3		0.814							
376	"	Methyl-3-isopropylidene-cyclohexane [2]	"	"	173-5		0.825							
377	"	Methyl-4-propylidene-cyclohexane [2]	"	"	172-4		0.815							
378	"	Δ^3 - β -Menthene [19]	"	"	175-7	0.8246 ^{4*}	0.8232	1.4563						
379	"	δ - Δ^3 - β -Menthene [7]	"	"	168		0.8073	1.44813 ^{3*}	1.44828					
380	"	Methyl-4-isopropylidene-cyclohexane [2]	"	"	172.4		0.831							
381	"	Dihydromonene [19]	"	"	168-9	0.8217 ¹	0.8217	1.45613						
382	"	1,2,4,5-Tetramethyl-1-cyclohexene [2]	"	"	166		0.817	1.457						
383	"	Isobornylane [20]	"	"	163.5-164.5		0.8317	1.4459						
384	"	Camphane [20]	"	153-4	160-1									
385	"	Isocamphane	"	"	62-3	0.8276 ^{2*}	0.8417	1.44186 ^{2*}						
a		d [20]			166-166.5									
b		f [20]			63-64.5									
c		dl [20]			65-6									
386	"	Fenchane [20]	"	"	<-15		0.8316	1.4412						
387	"	δ -Thujane [20]	"	"	149		0.8139	1.43759						
388	"	1,3-Diethyl-2-methyl-1-cyclopentene [2]	"	"	157		0.811	1.4506 ²						
389	"	1-Decyne [7]	"	-40	175 (80-2 ^{mp})		0.791							
390	"	2,7-Dimethyl-1,6-octadiene [2]	"	"	163.5-164.5									
391	"	3,7-Dimethyl-2,4-octadiene [8]	"	"	172 (58 ^{mp})		0.7933	1.456						
392	"	Dihydromycene [19]	"	"	166-8	0.7802 ^{3*}	0.7768	1.4507						
393	C ₁₆ H ₃₄	tert-Butylcyclohexane [2]	140.15	"	166-7	0.8305 ^{1*}	0.8274							
394		1-Methyl-3-propylcyclohexane [2]			164-5									
395		<i>o</i> -Menthane [10]			171				0.8135 ² [2]	0.8141	1.447 ^{2*}	1.447		
396		<i>m</i> -Menthane [10]			168.2					0.790	1.4420	1.4420		
397		<i>p</i> -Menthane [10]			170					0.793	1.437	1.437		
398		1,2,4,5-Tetramethylcyclohexane [2]			161					0.785	1.434	1.434		
399		Isothujane [20]			"					159.5-160.5	0.7910 ^{1*}	0.7889	1.4344 ^{1*}	1.4333
400		1,2-Diisopropylcyclobutane [2]			"					157-158.5	0.7901 ^{6*}	0.7763		
401		1,1,2-Trimethyl-3-isopropylcyclobutane [2]			"					145-6		0.7598		
402		"			1-Decene [10]				-87 [7]	172	0.765 ^{4*}	0.748	1.4385 ^{1*}	1.4372
403		"			3-Decene [10]					161				
404		"			2,6-Dimethyl-1(or 2)-octene [10]					169	0.789 ^{4*}	0.774	1.4484 ^{4*}	1.4496
405		"			2,3-Dimethyl-2-octene [10]				"	168 (162 ^{mp})		0.748		
406		"			2,7-Dimethyl-2-octene [2]				"	159-62	0.7475 ^{2*}	0.7474		
407		"			3,7-Dimethyl-2-octene [2]				"	162-3	0.7490 ^{2*}	0.7489		
408	"	6-Methyl-3-cethyl-2-hexene [10]	"	158.4	0.761 ^{4*}	0.745	1.4271							
409	"	3,5,5-Trimethyl-3-heptene [10]	"	157.5	0.788 ¹	0.772								
410	C ₁₀ H ₂₂	<i>n</i> -Decane [18]	142.17	-29.76	174.06		0.73014	1.41203						

TABLE I (cont)

Ref no	Formula	Name	Mol wt	Melting-point, °C	Boiling-point, at 760 mm., °C	Density g/ml		Refractive index	
						at t° C	at 20° C	n _D ²⁰	n _D ²⁰
411	C ₁₁ H ₂₂	2-Methylnonane [10]	142.17		160.0	0.728 ²¹	0.724		1.408
412	"	3-Methylnonane [10]	"		166.9	"	0.735		1.4126
413	"	5-Methylnonane [10]	"		166.2	"	0.732		1.4116
414	"	2,6-Dimethyloctane [8]	"		158-9	0.734 ¹⁸	0.730	1.4135 ¹⁸	1.4114
415	"	2,7-Dimethyloctane [8]	"	-52.8 [10]	159.6	0.72640 ¹⁸	0.72274	1.41049 ¹⁸	1.40842
416	"	3,6-Dimethyloctane	"						
a	"	d [8]	"		160-1	0.7348 ¹⁸	0.7296		
b	"	d [8]	"		159-60	0.7402 ¹⁸	0.7365	1.4145 ¹⁸	1.4137
417	"	4-Propylheptane [10]	"		161.7	0.740 ¹⁸	0.736		1.414
417.1	"	2,2,6-Trimethylheptane [5]	"		152.0	"	0.721		
418	C ₁₁ H ₁₈	1-Methylnaphthalene [10]	142.08	-22	243		1.025		1.618
419	"	2-Methylnaphthalene [10]	"	35.1	245		1.029	1.6026 ¹⁸	
420	C ₁₁ H ₁₆	n-Amylbenzene [7]	148.12	-78.25	202.1	0.860 ¹⁸	0.862	1.4751 ¹⁸	1.4730
421	"	Isoamylbenzene [10]	"		194	"	0.885		
422	"	(1-Methylbutyl)benzene [7]	"		189.3	0.874 ¹⁸	0.870		
423	"	tert-Amylbenzene [10]	"		189.3	0.8736 ¹⁸	0.8697	1.49154 ¹⁸	1.49285
425	"	1-Methyl-2-n-butylbenzene [8]	"		201	0.87023 ¹⁸	0.86871	1.49662 ¹⁸	1.49576
426	"	1-Methyl-3-n-butylbenzene [8]	"		197-8	0.8624 ¹⁸	0.8609	1.49315 ¹⁸	1.49229
427	"	1-Methyl-4-n-butylbenzene [8]	"		198-9	0.86132 ¹⁸	0.85672	1.4912 ¹⁸	1.4886
428	"	o-tert-Butyltoluene [8]	"		171-172 (170-171) ¹⁸			1.49423 ¹⁷	1.49287
429	"	m-tert-Butyltoluene [8]	"		186-8 (191-3)				
430	"	p-tert-Butyltoluene [8]	"		192-3 (190)	0.8614 ¹⁸	0.8598	1.4936 ¹⁷	1.4923
431	"	1-Ethyl-3-isopropylbenzene [7]	"	<-20	190-2	"			
432	"	1-Ethyl-4-propylbenzene [7]	"		202-5	0.867 ¹⁸	0.862		
433	"	1-Ethyl-4-isopropylbenzene [7]	"	<-20	197-8	0.8606 ¹⁸	0.8576		
434	"	1,2-Dimethyl-4-propylbenzene [10]	"	<-20	209				
435	"	1,3-Dimethyl-4-propylbenzene [10]	"	<-20	208.5				
436	"	1,4-Dimethyl-2-propylbenzene [10]	"	<-20	207				
437	"	3,4-Dimethylcumene [8]	"		200 (198) ¹⁸	0.8740 ¹⁸	0.8702	1.50001 ¹⁸	1.49783
438	"	1-Methyl-3,5-diethylbenzene [10]	"		200		0.879		
439	"	Pentamethylbenzene [8]	"	53	230	0.847 ¹⁸		1.50489 ¹⁸	
440	C ₁₁ H ₁₈	Noncycloheptasantalene [20]	150.41		183.5		0.885	1.46856	1.46856
441	"	Methyl-8-fenchene [20]	"		160-2		0.85205		1.46261
442	C ₁₁ H ₁₈	1,2,3-Trimethyl-1-cyclopentene [2]	152.15		181.5		0.814	1.451 ¹⁸	
443	C ₁₁ H ₁₈	(1,1-Dimethylpropyl)cyclohexane [2]	154.17		191-2	0.8226 ¹⁸	0.8199		
444	"	1-Hendecene [10]	"		188		0.763		
445	"	2-Hendecene [7]	"		193		0.7729	1.4333	
446	"	4,8-Dimethyl-4-nonenone [2]	"		165-9	0.7530 ¹⁸	0.7568		
447	C ₁₁ H ₂₂	n-Hendecane [18]	156.18	-25.65	195.84		0.74025		1.41727
448	"	5-Ethylnonane [10]	"		180 (71) ¹⁸	0.751 ¹⁸	0.750		
449	C ₁₀ H ₈	Acenaphthylene [8]	152.06	92-3	265-75 (decomp)	0.899 ¹⁸	0.896	1.402 ₁ (solid-bisaxial) [10] 1.463 ₂ (" ") [10] 1.617 ₃ (" ") [10]	
450	"	Diphenylene [8]	"	75		"	"		
451	C ₁₀ H ₈	Acenaphthene [10]	154.08	95	277.5	1.024 ¹⁸	"	1.6048 ¹⁸ 1.407 ₁ (solid-bisaxial) 1.466 ₂ (" ") 1.620 ₃ (" ")	

THE PROPERTIES OF PURE HYDROCARBONS

1337

TABLE I (cont)

Ref no	Formula	Name	Mol wt	Melting-point, °C	Boiling-point, at 760 mm, °C	Density g/ml		Refractive index	
						at t° C	at 20° C	n _D ²⁰	n _D ²⁵
452	C ₁₂ H ₁₂	Diphenyl [7]	154.08	69-71	254-5	0.9919 ^m 1.180 ^a		1.58822 ^m 1.56841 ^a 1.59441 ^a 1.61158 ^a	
453	C ₁₂ H ₁₈	1-Ethynaphthalene [10]	156.09	<-14	258 (decomp)	1.0641 ⁱ	1.059		
454	"	2-Ethynaphthalene [10]	"	-19	251	1.008 ^a	0.992		
455	"	1,2-Dimethylnaphthalene [8]	"		264 (139-40 ¹¹)	1.0251 ^a	1.022	1.61051 ^a	1.6088
456	"	1,4-Dimethylnaphthalene [8]	"	<-10 [10]	262-4	1.01803 ^a	1.0150	1.61567 ^a	1.61382
457	"	1,5-Dimethylnaphthalene [8]	"	80-80.5					
458	"	1,6-Dimethylnaphthalene [8]	"		262-3	1.0056 ¹²	1.0017		
459	"	1,7-Dimethylnaphthalene [8]	"	84-5					
460	"	1,8-Dimethylnaphthalene [8]	"	<-20					
461	"	2,3-Dimethylnaphthalene [7]	"	-20	266		1.008		
462	"	2,6-Dimethylnaphthalene [8]	"	110-11	261-2				
463	"	2,7-Dimethylnaphthalene [8]	"	96-7	262				
464	C ₁₂ H ₁₈	Phenylcyclohexane [7]	160.12	7	237.5		0.9440		
465	"	Isobutylbenzene [7]	"		214-15		0.857		
466	"	1-Ethyl-4-isobutylbenzene [7]	"		209-13				
467	"	1,4-Diisopropenyl-1,4-cyclohexadiene [2]	"		117-117.5				
468	C ₁₂ H ₁₈	1-Methyl-3(2,2-Dimethylpropyl)benzene [10]	162.14		208		0.8673		
469	"	1,3-Dimethyl-5-tertbutylbenzene [8]	"		200-5				
470	"	1,2,4-Trimethylbenzene [7]	"		218	0.8819 ¹⁷	0.8796		1.4972
471	"	1,3,5-Trimethylbenzene [10]	"		218		0.863		1.4939
472	"	Hexamethylbenzene [10]	"	166	265				
473	C ₁₂ H ₁₈	Dicyclohexyl [8]	166.17	2.25 (4)	233 (238)	0.8862 ¹⁸	0.8866 (0.8914)		1.4766 (1.4842)
474	C ₁₂ H ₂₂	(1,1-Dimethylbutyl)cyclohexane [2]	168.19		206-7	0.8372 ¹⁸	0.8346		
475	"	(1-Methyl-1-ethylpropyl)cyclohexane [2]	"		207-8	0.8310 ¹⁸	0.8284		
476	"	1-Methyl-2-isomethylcyclohexane [2]	"		204	0.812 ⁷	0.809		
477	"	1-Dodecene [7]	"	-31.5	213-15	0.7621 ¹	0.759		
478	"	2,5,8-Trimethyl-4-nonene [2]	"		197 (74 ⁹)	0.7768 ⁸	0.7642		
479	"	2,5-Dimethyl-3-isobutyl-2-hexene [2]	"		183 (65 ¹⁹)				
480	C ₁₂ H ₂₄	n-Dodecane [8]	170.20	-9.73	216.23	0.74542 ²⁰	0.74891		1.42188
481	"	5-Propylnonane [10]	"		205		0.736		1.4228
482	"	2,4,5,7-Tetramethyloctane	"		210				
483	C ₁₂ H ₁₀	Fluorene [10]	166.08	116	295				
484	C ₁₂ H ₁₈	Diphenylmethane [7]	168.09	26-7	261-2	1.0008 ²¹	1.00551	1.57884 ¹⁷	1.57748
485	"	1-Methyl-2-phenylbenzene [7]	"		260		1.010		
486	"	1-Methyl-3-phenylbenzene [7]	"		277	1.031 ^a	1.016		

TABLE I (cont)

Ref	Formula	Name	Mol wt	Melting-point, °C	Boiling-point, at 760 mm., °C	Density g/ml		Refractive index	
						at 1° C	at 20° C	n_D^{20}	n_D^{25}
487	C ₁₃ H ₂₂	1-Methyl-4-phenylbenzene [7]	168.09	-3	267	1.015 ⁹⁷	1.020		
488	C ₁₂ H ₁₈	Irene [19]	174.14		248 (113-15 ⁹⁸)		0.9402		1.5274
489	C ₁₂ H ₁₈	(1-Methyl-1-ethylbutyl)-cyclohexane [2]	182.20		224-6	0.8406 ¹⁴	0.8381		
490	"	(1,1,3-Trimethylbutyl)-cyclohexane [2]	"		220-1	0.8304 ¹⁴	0.8279		
491	"	(1,1-Diethylpropyl)cyclohexane [2]	"		222-3	0.8388 ¹⁴	0.8363		
492	"	Tridecene [7]	"		232.7		0.7977		
493	C ₁₂ H ₂₄	<i>n</i> -Tridecane [10]	184.22	-6.2	234		0.757	1.4419 ¹⁴	1.4406
494	"	4-Propyldecane [10]	"		221.2	0.765 ¹⁴	0.761		1.427
495	"	5-Butylnonane [10]	"				0.760		1.427
496	C ₁₈ H ₁₈	Anthracene [7]	178.08	217	354-5	1.25 ⁹¹			
497	"	Phenanthrene [10]	"	99.6	340.2	1.063 ¹⁴	1.025	1.6567 ¹⁴	
498	"	Diphenylacetylene [7]	"	62.5 (60)	300				
499	C ₁₈ H ₁₈	9,10-Dihydroanthracene [7]	180.09	108.5	305	0.8976 ¹¹			
500	"	9,10-Dihydrophenanthrene [8]	"	34.5-35	300 (168-9 ⁹⁹)				
501	"	1,1-Diphenylethylene [8]	"	8	277	1.018 ¹⁴	1.033	1.610 ¹⁴	1.607
502	"	<i>trans</i> -1,2-Diphenylethylene [7]	"	124	307	0.970 ¹⁴ 1.164 ²			
503	C ₁₈ H ₁₈	1,2-Diphenylethane [10]	182.11	52.5	284	0.9424 ¹⁴	0.995 [7]	1.539 ¹⁴	
504	"	1,1-Diphenylethane [10]	"		272	1.0060 ¹¹			1.5761
505	"	<i>m</i> -Benzyltoluene [7]	"		276 (275 ¹⁰⁰)	0.997 ¹⁴	0.995		
506	"	<i>p</i> -Benzyltoluene [7]	"	-30	285-6 (279-80) 260-5	0.995 ¹⁴	0.993		
507	"	1,3-Dimethyl-2-phenylbenzene [8]	"		270-6				
508	"	1,3-Dimethyl-4-phenylbenzene [8]	"		273-6				
509	"	1,3-Dimethyl-5-phenylbenzene [8]	"		273-6				
510	"	<i>o,o'</i> -Ditolyl [8]	"	18	259 (258 ¹⁰¹)	0.955 ¹⁴	0.947		
511	"	<i>o,m'</i> -Ditolyl [8]	"		270				
512	"	<i>o,p'</i> -Ditolyl [8]	"		273-6				
513	"	<i>m,m'</i> -Ditolyl [8]	"	5-7	288 (286-7 ¹⁰²)	0.9993 ¹⁴	0.9963		
514	"	<i>m,p'</i> -Ditolyl [8]	"	14-15	288-9		0.998		1.59713
515	"	<i>p,p'</i> -Ditolyl [8]	"	125 (117-19)	295 292-3	0.917 ¹⁰³ [7]	1.102		
516	C ₂₀ H ₁₈	α -Hexahydroanthracene [10]	84.12	63	290				
517	"	Apocadalene [8]	"		282		0.9833		1.5884
518	C ₁₈ H ₁₈	Decahydroanthracene [2]	188.15	73-4					
519	C ₁₈ H ₁₈	1,2,3,4-Tetraethylbenzene [10]	190.17		254		0.887		1.5083
520	"	1,2,4,5-Tetraethylbenzene [10]	"	13	250		0.888		4.5025
521	C ₁₈ H ₂₄	Dodecahydroanthracene [2]	192.19	88-9					
522	"	Dodecahydrophenanthrene [2]	"	< -15	270-6				
523	C ₁₄ H ₂₆	1-Tetradecane [10]	196.22	-12	246		0.775		
524	C ₁₄ H ₂₆	<i>n</i> -Tetradecane [10]	198.23	5.5	252.5		0.765		1.4459
525	C ₁₂ H ₁₄	Fluoranthene [10]	190.08	110	353 (25 ¹⁰⁴)				
526	"	Succosterene [10]	"	160	300				

THE PROPERTIES OF PURE HYDROCARBONS

1339

TABLE I (cont)

Ref no	Formula	Name	Mol wt	Melting-point, °C	Boiling-point, at 760 mm °C	Density g/ml		Refractive index	
						at 0° C	at 20° C	n_D^{20}	n_D^{25}
527	C ₁₂ H ₁₈	1-Methylanthracene [10]	192.09	86	200	1.0477 ¹¹		1.6803 ¹¹	
528	"	2-Methylanthracene [10]	"	207	subl [7]				
529	"	9-Methylanthracene [10]	"	90		1.066 ¹¹		1.6959 ¹¹	
530	"	1-Methylphenanthrene [7]	"	123					
531	"	3-Methylphenanthrene [7]	"	65					
532	C ₁₆ H ₁₈	1,1-Diphenyl-1-propylene [7]	194.11	51.5-52	284.5	0.984 ¹¹			
533	"	1,2-Diphenyl-1-propylene [8]	"	82	285-6	0.9857 ¹¹		1.5635 ¹¹	
534	"	1,3-Diphenylpropylene (isomer 1) [8]	"		112 (178-9 ¹¹)				
a	"	(isomer 2) [8]	"	57					
b	"	3,3-Diphenyl-1-propylene [8]	"		293				1.596
536	C ₁₆ H ₁₈	1,1-Diphenylpropane [8]	196.12		278.5-280.5	0.9881 ¹¹	0.9912	1.569 ¹¹	1.571
537	"	1,2-Diphenylpropane [8]	"		280-2	0.9857 ¹¹	0.9833	1.5615 ¹¹	1.5621
538	"	1,3-Diphenylpropane [8]	"	< -20 [10]	302	1.007 ¹¹	1.005	1.5745 ¹¹	1.5736
539	"	2,2-Diphenylpropane [8]	"	29	282-3	0.9958 ¹¹	0.9997	1.570 ¹¹	1.572
540	"	1-Ethyl-4-benzylbenzene [7]	"		294.5	0.985 ¹¹	0.984		
541	"	Di-p-tolylmethane [8]	"	28	285.5-286.5				
542	C ₁₆ H ₁₈	Azulene [8]	198.14		308 (167-8 ¹¹)	0.9738 ¹¹	0.9773		
543	"	Guazulene [20]	"		304 (164 ¹¹)	0.9759 ¹¹	0.9745		
544	"	Cadalene [8]	"		293 (291-2 ¹¹)	0.9792 ¹¹	0.9785	1.5851 ¹¹	1.5847
545	"	1,7-Dimethyl-4-isopropyl-naphthalene [8]	"	60					
546	"	1,4-Dimethyl-6-isopropyl-naphthalene [8]	"		287 (155-7 ¹¹)				
547	"	1,5-Dimethyl-7-isopropyl-naphthalene [8]	"		301 (110-12 ¹¹)				
548	C ₁₈ H ₂₂	Calamenene [20]	202.17		263 (136-43 ¹¹)	0.9324 ¹¹	0.9309		1.5317
549	C ₁₈ H ₂₄	Aromadendrene [20]	204.19		252 (121 ¹¹)		0.9116		1.4978
550	"	Atreatylene [10]	"		267 (141 ¹¹)		0.927		1.5057
551	"	Calamene [20]	"		242 (123-6 ¹¹)	0.9224 ¹¹	0.9209		1.50572
552	"	Cannibene [10]	"		259	0.897 ¹¹	0.894		
553	"	Cedrene [20]	"		264	0.9367 ¹¹	0.9333		1.4980
						(0.9367 ¹¹)	(0.9347)	(1.5030 ¹¹)	(1.5019)
554	"	Clovene [20]	"		240 (111-13 ¹¹)		0.924		1.4980
555	"	α -Costene [20]	"		250 (122-6 ¹¹)	0.9014 ¹¹	0.9020	1.49807 ¹¹	1.4968
556	"	β -Costene [20]	"		268 (144-9 ¹¹)	0.8728 ¹¹	0.8740		1.4905
557	"	<i>l</i> - α -Curcumene [20]	"		264 (128-30 ¹¹)	0.853 ¹¹	0.8655	1.4944 ¹¹	1.4978
558	"	<i>l</i> - β -Curcumene [20]	"		273 (128-30 ¹¹)	0.8810 ¹¹	0.8830	1.4940 ¹¹	1.4973
559	"	Guajene [20]	"		257 (128-30 ¹¹)	0.9115 ¹¹	0.9109		1.5022
560	"	Guajene [10]	"		258 (124 ¹¹)		0.908		1.5005
561	"	α -Gurjunene [20]	"		243 (114-16 ¹¹)		0.918		1.5010
562	"	β -Gurjunene [20]	"		245 (120-31 ¹¹)		0.9348		1.5027
563	"	Humulene [20]	"		263-6	0.9001 ¹¹	0.8963	1.5021 ¹¹	1.5018
564	"	Isocadinene [20]	"		245 (124-6 ¹¹)		0.914		1.515
565	"	Isoclovene [20]	"		257 (130-11 ¹¹)	0.843 ¹¹	0.842	1.5039 ¹¹	1.5036
566	"	Ledene [20]	"		264	0.9237 ¹¹	0.9231		
567	"	Longifolene [20]	"		257 (254-6 ¹¹)	0.9284 ¹¹	0.9309	1.4950 ¹¹	1.4885
568	"	Patchoulene [20]	"		254 (252-3 ¹¹)		0.9296		1.49835
569	"	Sesquiteronellene [2]	"		277 (138-40 ¹¹)		0.8489		1.5325
570	"	Cadinene	"		268	0.9260 ¹¹	0.9235	1.50934 ¹¹	1.50795
a	"	<i>d</i> [20]	"		(138-40 ¹¹)				
b	"	<i>l</i> [8]	"		274-5		0.9189		1.5079

TABLE I (cont)

Ref no	Formula	Name	Mol wt	Melting-point, °C	Boiling-point, at 760 mm., °C	Density g/ml		Refractive index	
						at t° C	at 20° C	n_D^{20}	$n_D^{20} \sigma$
571	C ₁₅ H ₂₄	Isosongiberene [20]	204	19	258 (120-3 ^a)		0 9150		1 5034
572	"	α-Selinene [20]	"	"	260 (128-30 ¹¹)		0 9190		1 50920
573	"	β-Selinene [20]	"	"	260 (136-9 ¹¹)		0 9107		1 50311
574	"	Copaene [20]	"	"	250 (119-20 ¹¹)	0 9077 ¹²	0 9045		1 4894
575	"	α-Caryophyllene [10]	"	"	260		0 906		1 4996
576	"	γ-Caryophyllene [20]	"	"	247 (125- 125 5 ¹⁴)	0 8995 ¹⁴	0 89888	1 49665 ¹⁴	1 49630
577	"	2-Methyl-6(p-totyl)-heptane [20]	"	"	263 (135 ¹⁴)				
578	"	Bisabolene [8]	"	"	262 (133-4 ¹⁹)	0 8717 ¹¹	0 8723	1 4923 ¹¹	1 4926
579	"	Zingiberene [20]	"	"	260 (134 ¹⁴)		0 8684		1 4956
580	"	Elemene [20]	"	"	246 (115-17 ¹⁹)		0 8797		1 4971
581	"	1,3-Dicyclopentyl-1-cyclopentene [2]	"	"	290		0 939		
582	"	α-Santalene [20]	"	"	257 (118 ⁷)	0 9132 ¹⁸	0 9101	1 4921 ¹⁸	1 4904
583	"	β-Santalene [20]	"	"	267 (125-6 ⁷)		0 8940		1 4946
584	"	γ-Santalene [10]	"	"	250 (120 ¹⁹)		0 936		1 5042
585	"	α-Farnesene [20]	"	"	267 (128-30 ¹⁹)	0 8385 ¹⁴	0 8374		1 4965
586	C ₁₆ H ₂₄	Dihydroaromadendrene [20]	206	20	252 (121-2 ¹⁹)	0 9014 ¹¹	0 8995	1 4871 ¹¹	1 4861
587	"	Dihydroguaiaene [20]	"	"	250 (121-2 ¹⁹)		0 8914		1 49817
					247 (124-5 ¹⁹)		0 8955		1 4894
588	"	Dihydro-β-gurjunene [20]	"	"	255 (120 ⁹)		0 9258		1 49775
589	"	Elemene [20]	"	"	248 (115-19 ¹⁹)	0 8830 ¹⁷	0 8811	1 4950 ¹⁷	1 4940
590	"	Ferulene [10]	"	"	266 (126 ⁷)		0 870		
591	"	Isodihydrocaryophyllene [20]	"	"	255 (137-8 ¹¹)		0 919		1 4925
592	"	Octahydroguaiazulene [20]	"	"	253 (123-5 ¹¹)	0 8872	0 8872		1 4834
593	"	Dihydrocadinene [20]	"	"	262 (129-31 ¹⁹)	0 8999 ¹²	0 8945	1 4952 ¹⁹	1 4922
594	"	Dihydroeudesmene [20]	"	"	265 (132-3 ¹⁹)		0 9080		1 4972
595	"	Dihydrocopaene [20]	"	"	245 (118-21 ¹⁹)	0 9826 ¹¹	0 9812	1 4799 ¹⁴	1 4792
596	"	Dihydrozingiberene [20]	"	"	264 (122-5 ⁷)		0 8557		1 4837
597	"	Dihydro-α-santalene [20]	"	"			0 899		1 495
598	C ₁₆ H ₂₄	Tetrahydrocalamene [20]	208	22	255 (123-5 ¹⁹)	0 8951 ¹¹	0 8937		1 4848
599	"	Tetrahydroeudesmene [20]	"	"	260 (117 ⁹)		0 8896		1 4842
600	"	Tetrahydroguaiaene [20]	"	"	258 (118-19 ⁷)		0 8806		1 47840
601	"	Tetrahydroisozingiberene [20]	"	"	255 (123 ¹⁹)		0 8822		1 4791
602	"	Tetrahydrocadinene [20]	"	"	259 (125-8 ¹⁹)		0 8838		1 48045
603	"	Tetrahydroelinene [20]	"	"	258 (125-6 ¹⁹)		0 8889		1 48375

THE PROPERTIES OF PURE HYDROCARBONS

1341

TABLE I (cont)

Ref no	Formula	Name	Mol wt	Melting-point, °C	Boiling-point, at 760 mm., °C	Density g/ml		Refractive index	
						at <i>r</i> ° C	at 20° C	<i>n</i> _D ²⁰	<i>n</i> _D ²⁵
604	C ₁₀ H ₁₈	Tetrahydrocaryophyllene [20]	208.22		249 (122-31 ^a)		0.8712		1.4700
605	"	Tetrahydrobisabolene [20]	"		246 (125 ^{1b})	0.857 ^{1a}	0.854		
606	"	Tetrahydroelemene [20]	"		244 (118-20 ^{1b})		0.8576		1.4760
607	"	Tetrahydrosantalene [20]	"		249 (116-18 ^a)		0.864		1.4676
608	"	Tetrahydro- α -santalene [20]	"		248 (115-16 ^a)		0.8655		1.4691
609	"	Tetrahydro- β -santalene [20]	"		238 (109 ^{1b})		0.8550		1.46612
610	C ₁₀ H ₁₈	Hexahydro- α -curcumene [20]	210.23		270 (128 ^a)	0.8283 ^{1a}	0.8304	1.4952 ^{1a}	1.4986
611	"	Hexahydro- β -curcumene [20]	"		270 (128 ^a)	0.8283 ^{1a}	0.8304	1.4582 ^{1a}	1.4613
612	"	Hexahydrobisabolene [20]	"		260 (123-9 ^a)		0.8244		1.45423
613	"	Hexahydrozingiberene [20]	"		260 (128-30 ^{1b})		0.8264		1.4560
614	"	Hexahydroelemene [20]	"		244 (114-16 ^{1b})		0.8450		1.4621
615	C ₁₅ H ₃₂	<i>n</i> -Pentadecane [7]	212.25	10	270.5		0.7689		
616	"	Farnesane [20]	"		248 (120 ^{1a})	0.7682 ^{1a}	0.7709	1.4303 ^{1a}	1.4318
617	C ₁₆ H ₁₈	Pyrene [10]	202.08	150	>360				
618	"	1,4-Diphenyl-1,3-butadiene [8]	"	88					
619	C ₁₆ H ₁₈	1-Phenylnaphthalene [10]	204.09		325				
620	"	2-Phenylnaphthalene [10]	"	102.5	345				
621	"	Pseudophenanthrene [10]	"	115					
622	C ₁₆ H ₁₄	Atronene [10]	206.11		326				
623	"	9-Ethylanthracene [10]	"	59		1.041 ^{1a}		1.6762 ^{1a}	
624	"	1,3-Dimethylanthracene [8]	"	83					
625	"	1,4-Dimethylanthracene [8]	"	74					
626	"	2,3-Dimethylanthracene [8]	"	252					
627	"	2,6-Dimethylanthracene [8]	"	250					
628	"	2,7-Dimethylanthracene [8]	"	241					
629	"	2,9-Dimethylanthracene [8]	"	85					
630	"	3,9-Dimethylanthracene [8]	"	85					
631	"	9,10-Dimethylanthracene [8]	"	180-1					
632	"	1,3-Dimethylphenanthrene [8]	"	76-7					
633	"	1,7-Dimethylphenanthrene [8]	"	85-6					
634	"	9,10-Dimethylphenanthrene [7]	"	139	subl				
635	"	1,4-Diphenyl-1,3-butadiene <i>cis</i> [8]	"	70					
		<i>trans</i> [8]	"	148	350				
		<i>cis-trans</i> [8]	"	only liquid (unstable)					
636	C ₁₂ H ₁₈	1,1-Diphenyl-1-butene [8]	208.12	only liquid	295-7	1.03 ^{1a}	1.03	1.5915 ^{1a}	1.5906
637	"	1,2-Diphenyl-1-butene [8] (isomer) [8]	"	oil	296-7 294-6	1.024 ^{1a}	1.022	1.593 ^{1a}	1.592

TABLE I (cont)

Ref no	Formula	Name	Mol wt	Melting-point, °C	Boiling-point, at 760 mm., °C	Density g/ml		Refractive index	
						at t° C	at 20° C	n_D^{20}	n_D^{30}
638	C ₁₈ H ₁₈	1,3-Diphenyl-1-butene [8]	208.12	liquid	310-12	1.016 ¹⁸	1.012	1.590 ¹⁸	1.588
639	"	1,4-Diphenyl-1-butene [8]	"	124					
640	"	1,4-Diphenyl-2-butene [8]	"	45					
641	"	2,3-Diphenyl-2-butene	"						
a	"	cis [8]	"	66					
b	"	trans [8]	"	107					
642	"	2,4-Diphenyl-2-butene [8]	"			1.0149 ¹¹	1.0157		
643	"	2,2'-Dimethylstilbene [8]	"	83	306 (169-70 ¹³) 322 (176-80 ¹⁴)				
644	"	3,3'-Dimethylstilbene [8]	"	55-6					
645	"	4,4'-Dimethylstilbene [8]	"	179-80	304-5				
646	"	9,10-Dihydro-9-ethyl-anthracene [7]	"	oil	320	1.049 ¹³	1.048		
647	C ₁₈ H ₁₈	1,1-Diphenyl-n-butane [8]	210.14	27	286-8 266 (1.006 ¹⁷) 289 (1.0092 ¹⁴) 295 317	0.9748 ¹⁷ 1.0076	1.554 ¹⁸ (1.577 ¹⁹) 1.587 ¹⁸	1.586	
648	"	1,2-Diphenyl-n-butane [8]	"	oily liquid					
649	"	1,3-Diphenyl-n-butane [8]	"	oil					
650	"	1,4-Diphenyl-n-butane [8]	"	52					
651	"	2,2-Diphenyl-n-butane [8]	"	127-8					
652	"	2,3-Diphenyl-n-butane	"						
a	"	d [8]	"						
b	"	l [8]	"						
c	"	dl [8]	"	8	283-4		0.9757	1.5516	
d	"	meso	"	126					
653	"	1,2-Di-o-tolyethane [8]	"	66-7	300 (177 ¹⁶) 277 298 306 (178 ¹⁵)				
654	"	1,2-Di-m-tolyethane [8]	"						
655	"	1,2-Di-p-tolyethane [8]	"	85					
656	C ₁₈ H ₁₈	Pentaethylbenzene [10]	218.20	< -20			0.896	1.516	
657	C ₁₈ H ₃₄	2-Hexadecene [7]	222.23	-25	280-5				
658	C ₁₈ H ₃₄	1-Hexadecene [10]	224.25	4	274		0.789	1.442	
659	C ₁₈ H ₃₄	n-Hexadecane [7]	226.26	20	287.5		0.7751		
660	"	7,8-Dimethyltridecane [10]	"		267.5	0.792 ¹⁴	0.788		
661	C ₁₇ H ₁₄	1-Benzyl-naphthalene [10]	218.11	59	350	1.165 ⁴			
662	"	2-Benzyl-naphthalene [10]	"	35.5	350	1.176 ⁴			
663	C ₁₇ H ₁₄	1,2,4-Trimethylantracene [10]	220.12	243					
664	"	1,3,6-Trimethylantracene [10]	"	222					
665	"	1,4,6-Trimethylantracene [10]	"	227					
666	C ₁₇ H ₁₆	8-Heptadecene [10]	238.26		300 (160 ¹⁷)	0.798 ¹⁴	0.791 0.778	1.437	
667	C ₁₇ H ₃₄	n-Heptadecane [10]	240.28	22.5	303			1.437	
668	C ₁₈ H ₁₄	Benzanthrene [10]	228.09	84					
669	"	Truxene [10]	"	>360					
670	"	Chrysenes [8]	"	254 (250)	448				
671	"	Triphenylenes [10]	"	198.5					
672	C ₁₈ H ₁₄	1,3-Diphenylbenzene [8]	230.11	86-7	363				
673	"	1,4-Diphenylbenzene [7]	"	213	427	1.234 ⁴			
674	"	Diphenylfulvene [8]	"	82					
675	C ₁₈ H ₁₈	Refene [10]	234.14	98.5	394	1.13 ¹⁸			
676	"	1,3,5,7-Tetramethyl-anthracene [10]	"	280 (decomp)					

THE PROPERTIES OF PURE HYDROCARBONS

1343

TABLE I (cont)

Ref no	Formula	Name	Mol wt	Melting-point, °C	Boiling-point, at 760 mm., °C	Density g/ml		Refractive index	
						at t° C	at 20° C	n _D ²⁰	n _D ²⁰ σ
677	C ₁₂ H ₂₂	1,2-Diphenylcyclohexane [8]	236 15	172					
678	"	1,4-Diphenylcyclohexane [8]	"		306 (190 ¹⁹)				
679	"	Dihydrodethylantracene [17]	"			1 014			
680	C ₁₂ H ₁₈	1,4-Diisobutyl-naphthalene [17]	240 19			0 933		1 5380 ¹⁸	
681	C ₁₂ H ₂₂	Hexaethylbenzene [10]	246 23	129	298	0 831 ^{18a} *		1 480 ^{18a} *	
682	C ₁₂ H ₂₂	Fichtelite [10]	248 25	46			1 010	1 544 _a (solid-biaxial)	1 572 _b (" ")
683	C ₁₂ H ₂₄	1-Octadecyne [10]	250 26	26	313 (180 ¹⁹)	0 798 ¹⁹			
684	"	2-Octadecyne [10]	"	30	318 (184 ¹⁹)		0 802		
685	C ₁₂ H ₂₂	1-Octadecene [10]	252 28	18	312 (179 ¹⁹)		0 791		
686	C ₁₂ H ₂₂	n-Octadecane [10]	254 29	28	317		0 777	1 4349 ¹⁸ *	
687	C ₁₂ H ₁₈	Triphenylmethyl [7]	243 12	145-7	(decomp)				
688	C ₁₂ H ₁₈	Triphenylmethane [10]	244 12	92 5	359 2	1 014 ¹⁹		1 5839 ¹⁹	
689	"	o-Benzylidiphenyl [7]	"	54	370 (283-7 ^{19a})				
690	"	p-Benzylidiphenyl [7]	"	85	370 (285-6 ^{19a})				
691	C ₁₂ H ₂₂	n-Nonadecane [10]	268 31	32	330	0 777 ¹⁸		1 436 ¹⁸ *	
692	C ₁₂ H ₁₈	Perylene [10]	252 09	264					
693	"	1,2-Benzpyrene [8]	"	176 5-177 5	488 (310-12 ¹⁹)				
694	"	4,5-Benzpyrene [8]	"	178-9	441 (250 ¹⁹ *)				
695	C ₁₂ H ₁₈	1 1'-Dinaphthyl [10]	254 11	160 5	360				
696	"	1,2'-Dinaphthyl [10]	"	80					
697	"	2,2'-Dinaphthyl [10]	"	187 8	452				
698	"	9-Phenylanthracene [10]	"	153	417				
699	C ₁₂ H ₁₈	Triphenylethylene [7]	256 12	72-3	364 (220-1 ¹⁹)				
700	C ₁₂ H ₁₈	Diphenyl-o-tolylmethane [8]	258 14	82-3					
701	"	Diphenyl-m-tolylmethane [7]	"	62	356 (354 ^{19a})	1 07 ¹⁸			
702	"	Diphenyl-p-tolylmethane [8]	"	71	363				
703	"	o-Dibenzylbenzene [8]	"	78			1 0535		
704	"	m-Dibenzylbenzene [8]	"		363 (226-7 ¹⁹)				
705	"	p-Dibenzylbenzene [8]	"	86	362 (225 ¹⁹)				
706	"	1,1,1-Triphenylethane [7]	"	95					
707	"	1,1,2-Triphenylethane [7]	"	54-54 5	348-9				
708	C ₁₂ H ₂₂	α-Camphorene [8]	272 25		332 (190-2 ¹⁹)		0 887		
709	C ₁₈ H ₃₈	n-Eicosane [10]	283 32	38	344 (205 ¹⁹)	0 778 ¹⁸ †		1 434 ¹⁸ *	1 4494

TABLE I (cont.)

Ref no	Formula	Name	Mol wt	Melting-point, °C	Boiling-point, at 760 mm., °C	Density g/ml		Refractive index	
						at t° C	at 20° C	n _D ²⁰	n _D ²⁵
710	C ₂₁ H ₄₂	Croceane [8]	283.32		341 (135°)		0.8027		1.4494
711	C ₂₂ H ₃₄	1,1'-Dinaphthylmethane [8]	268.12	109	423 (270°)				
712	"	1,2'-Dinaphthylmethane [8]	"	98					
713	"	1,2'-Dinaphthylmethane [8]	"	93					
714	"	1,1-Diphenylindene [8]	"	91-2					
715	"	1,2-Diphenylindene [8]	"	177-8					
716	"	1,3-Diphenylindene [8]	"	71-2	372 (230°)				
717	"	2,3-Diphenylindene [8]	"	108-9					
718	C ₂₁ H ₂₂	Phenyl-(di-p-tolyl)-methane [10]	272.15	56					
719	"	1,1,1-Triphenylpropane [7]	"	51-51.5					
720	C ₂₁ H ₄₂	9-Heneicosane [10]	294.32	3	350 (202°)	0.805 ¹⁴	0.802		
721	C ₂₁ H ₄₂	n-Heneicosane [10]	296.34	40.4	356 (215°)	0.775 ¹⁴		1.4344 ¹⁴	
722	C ₂₂ H ₃₄	1,2,5,6-Dibenzanthracene [8]	278.11	262					
723	"	1,2,7,8-Dibenzanthracene [8]	"	196					
724	"	Fluorene [10]	"	364	520				
725	C ₂₂ H ₃₀	1,1(1,1'-Dinaphthyl)-ethylene [8]	280.12	107					
726	"	1,2(1,1'-Dinaphthyl)-ethylene [8]	"	161					
727	"	1,2(2,2'-Dinaphthyl)-ethylene [8]	"	254-5					
728	C ₂₂ H ₄₂	n-Docosane [10]	310.35	44.4	368 (224.5°)	0.778 ¹⁴			
729	C ₂₂ H ₂₀	Diphenyl-β-naphthylmethyl [8]	293.13	135-40					
730	C ₂₂ H ₂₀	Diphenyl-β-naphthylmethane [8]	294.14	77-8					
731	C ₂₂ H ₄₂	n-Tricosane [10]	324.37	47.7	380 (234° [7])	0.7799 ¹⁴ [7]		1.4236 ¹⁴	
732	C ₂₄ H ₁₈	Coronene [8]	300.09	429-30					
733	C ₂₄ H ₁₈	1,3,5-Triphenylbenzene [10]	306.14	170			1.026	1.524, (solid-biaxial) 1.867 _B (" ") 1.873 _C (" ")	
734	"	1,2'-Dipenyldiphenyl [8]	"	118-19					
735	"	3,3'-Dipenyldiphenyl [8]	"	86					
736	C ₂₄ H ₁₈	4,4'-Dipenyldiphenyl [8]	306.14	318-19	610 (428°)				
737	"	7,7'-Diacenaphthyl [8]	"	120					
738	C ₂₁ H ₂₂	Dihydroisoamylanthracene [17]	320.25				0.972	1.5640 ¹⁶	
739	C ₂₄ H ₃₈	n-Tetracosane [10]	338.39	54	324.1	0.779 ¹⁴ [8]			
740	"	2-Methyltricosane [10]	"	51	293 (243°)				
741	"	4,8,12,16-Tetramethyltetracosane [8]	"		361 (218°)		0.8054		1.4502
742	C ₂₆ H ₃₀	Tetraphenylmethane [10]	320.15	285	431				

THE PROPERTIES OF PURE HYDROCARBONS

1345

TABLE I (cont)

Ref no	Formula	Name	Mol wt	Melting-point, °C	Boiling-point, at 760 mm., °C	Density g/ml		Refractive index	
						at t° C	at 20° C	n_D^{20}	n_D^{30}
743	C ₁₈ H ₁₈	5,5'-Diacenaphthylmethane [8]	320.15	140-1					
744	C ₂₅ H ₅₂	n-Pentacosane [10]	352.40	54	405 (284 ^{4b})		0.779		
745	C ₁₈ H ₁₈	Rubcene [10]	326.11	306					
746	C ₁₈ H ₁₈	Difluorenylene [8]	328.12	218					
747	C ₂₈ H ₅₂	Difluorenyl [8]	330.14	246					
748	"	9,10-Diphenylphenanthrene [8]	"	240 (235)					
749	C ₁₈ H ₁₈	Tetraphenylethylene [7]	332.15	227 (221)	425				
750	C ₁₈ H ₁₈	1,1,1,2-Tetraphenylethane [7]	334.17	144	423 (277-80 ^{4b})				
751	"	1,1,2,2-Tetraphenylethane [7]	"	211 (209)	383		1.182		
752	C ₂₁ H ₄₂	Carota [10]	350.29	167.8					
753	C ₂₁ H ₄₂	n-Hexacosane [10]	366.42	60	418 (296 ^{4b})		0.779		
754	"	2-Methylpentacosane [10]	"	61	430 (207 ^{4c})				
755	C ₁₉ H ₃₈	Tetraphenylpropadiene [7]	344.15	166					
756	C ₂₇ H ₅₄	Cholesterilene [8]	368.34	79					
757	C ₂₇ H ₅₄	Cholestene [8]	370.35	89-90					
758	"	pseudo-Cholestene [8]	"	78-9					
759	C ₂₇ H ₅₄	Cholestane [8]	372.37	80					
760	"	pseudo-Cholestane [8]	"	69-70					
761	C ₂₇ H ₅₄	n-Heptacosane [2]	380.43	59.5	423 (270 ^{4b})		0.7796 ^{4a}		
762	C ₂₈ H ₅₂	2,2'-Dianthryl [8]	354.14	355					
763	"	9,9'-Dianthryl	"	>360					
a	"	Isomer 1 [8]	"	312 (300)					
b	"	Isomer 2 [8]	"	"					
764	C ₂₈ H ₅₂	Dianthracene [8]	356.15	242-4					
765	C ₂₈ H ₅₂	1,1-Diphenylhexadecane [17]	378.34				0.9135	1.5121 ^{1b}	
766	C ₂₈ H ₅₂	1,1-Dicyclohexylhexadecane [17]	390.42				0.8791	1.4832 ^{2a}	
767	C ₂₈ H ₅₂	n-Octacosane [10]	394.45	65	446 (318 ^{4b})		0.779		
768	C ₂₈ H ₅₂	Spinacene [10]	396.37	<-20	427 (260 ⁹)	0.859 ¹²	0.857		1.4951
769	C ₂₈ H ₅₂	n-Nonacosane [10]	408.46	63.6	480 (348 ^{4b})		0.780		
770	C ₂₈ H ₅₂	Chalkacene [8]	376.12	358-60					
771	C ₂₈ H ₅₂	Dihydrodi-β-octylanthracene [18]	404.34				0.948		
772	C ₂₈ H ₅₂	1-Phenyl-2-benzylheptadecane [17]	406.35				0.9165	1.5123 ^{2a}	

TABLE I (cont)

Ref no	Formula	Name	Mol wt	Melting-point, °C	Boiling-point, at 760 mm., °C	Density g/ml		Refractive index	
						at 1° C	at 20° C	n_D^{20}	n_D^{25}
773	C ₂₈ H ₅₈	α -Amyriene	408.37	135	441 (285 ¹⁴)				
a		d [8]							
		l [8]	..	194					
774	..	β -Amyriene [8]	..	175-8					
775	C ₂₈ H ₅₈	1-Cyclohexyl-2-hexahydrobenzylheptadecane [17]	418.45				0.8860		1.4871 ¹⁴
776	C ₂₈ H ₅₈	Molene [10]	420.46	63	380		0.890		
777	C ₂₈ H ₅₈	<i>n</i> -Triacontane [10]	422.48	70	461 (235 ¹⁴)		0.780		
778		Anthemene [8]	..	64	440	0.942 ¹⁴			
779		Meissane [10]	..	74	472 (222 ¹⁴)				
780	C ₃₁ H ₆₄	<i>n</i> -Hentriacontane [10]	436.49	68.1	463 (302 ¹⁴)		0.781 ^{14, 1}		
781	C ₃₀ H ₆₂	Pentaphenylethane [10]	410.20	171					
782	C ₃₀ H ₆₂	<i>n</i> -Dotriacontane [10]	450.51	75	472 (310 ¹⁴)		0.775 ^{14, 4}		1.4331 ^{14, 4}
783	C ₃₀ H ₆₂	<i>n</i> -Tetraacontane [10]	478.54	76.5	487 (255 ¹⁴)		0.781		
784	C ₃₁ H ₆₄	<i>n</i> -Pentatriacontane [10]	492.55	74.7	500 (331 ¹⁴)		0.782 ^{14, 1}		
785	..	16- <i>n</i> -Butylhentriacontane [17]	..				0.8327		1.4579 ¹⁴
786	C ₂₈ H ₅₈	Decacyclene [8]	450.14	387					
787	C ₃₀ H ₆₂	<i>n</i> -Hexatriacontane [10]	506.57	76.5	500 (265 ¹⁴)		0.782 ¹⁴		
788	C ₂₈ H ₅₈	Hexaphenylethane [7]	486.23	145-7					
789	C ₄₀ H ₈₂	α -Carotene [7]	536.43	175					
790	..	β -Carotene [8]	..	184 (181-2)					
791	..	γ -Carotene [8]	..	178					
792	C ₂₈ H ₅₈	Chlorene [8]	602.20	265 (decomp)					
793	C ₂₈ H ₅₈	<i>n</i> -Pentacontane [2]	702.79	92.7-93	607 (420-2 ¹⁴)				
794	C ₂₈ H ₅₈	<i>n</i> -Tetrapentacontane [6]	758.85	95					
795	C ₂₈ H ₅₈	<i>n</i> -Hexacontane [2]	842.94	101-2					
796	C ₂₈ H ₅₈	<i>n</i> -Dohexacontane [6]	870.97	100.5					
797	C ₂₈ H ₅₈	<i>n</i> -Tetrahexacontane [6]	899.00	102					

TABLE II
 Dispersion in Pure Hydrocarbons

Ref no	Formula	Dispersion, $H_{\beta}-H$	Ref no	Formula	Dispersion, $H_{\beta}-H_n$	Ref no	Formula	Dispersion, $H_{\beta}-H_n$	Ref no	Formula	Dispersion, $H_{\beta}-H_n$
27	C_3H_8	0 0129	107	C_8H_{18}	0 0159	294	C_8H_{18}	0 0071	456	$C_{12}H_{26}$	0 0296 [10]
35	C_4H_{10}	0 0148	112	"	0 0087	298	$C_{10}H_{22}$	0 0287 [10]	480	$C_{14}H_{30}$	0 02755
37	"	0 0096	116	C_8H_{18}	0 0075	305	$C_{10}H_{22}$	0 0169	494	$C_{16}H_{34}$	0 0075
44	C_4H_{10}	0 0085 [10]	145	C_8H_{18}	0 00681	311	$C_{10}H_{22}$	0 0140	495	"	0 0074
48	C_4H_{10}	0 00627	148	"	0 0068 [10]	314	"	0 0146 [10]	503	$C_{10}H_{22}$	0 0187
49	"	0 0062	153	"	0 0068 [10]	315	"	0 0144 [10]	519	$C_{10}H_{22}$	0 0140
51	C_4H_{10}	0 0167	154	C_8H_{18}	0 0338	322	"	0 0144	527	$C_{10}H_{22}$	0 0541
53	"	0 0122	163	C_8H_{18}	0 0116	327	"	0 0157	529	"	0 0591
54	C_6H_{14}	0 0131 [10]	182	C_8H_{18}	0 0089	339c	$C_{10}H_{22}$	0 0116 [10]	534a	$C_{10}H_{22}$	[liquid]
58	C_6H_{14}	0 0095	198	C_8H_{18}	0 0076	357c	"	0 0109	534b	[solid]	
62	"	0 0098 [10]	210	"	0 0090	369	"	0 0172 [10]	623	$C_{10}H_{22}$	0 0536
69	C_6H_{14}	0 0075	215	C_8H_{18}	0 00698	397	$C_{10}H_{22}$	0 0078	656	$C_{10}H_{22}$	0 0143
80	"	0 0090	218	"	0 0070	402	"	0 0090	658	$C_{10}H_{22}$	0 0304
81a	"	0 0090 [10]	219	"	0 0070 [10]	410	$C_{10}H_{22}$	0 00734	667	$C_{10}H_{22}$	0 0076
81b	"	0 0090 [10]	223	"	0 0080 [10]	411	"	0 0072	681	$C_{10}H_{22}$	0 0133
87	C_6H_{14}	0 00669	230	C_8H_{18}	0 0234	415	"	0 0072 [10]	686	$C_{10}H_{22}$	0 0075
88	"	0 0065	232	C_8H_{18}	0 0168	417	"	0 0072	688	$C_{10}H_{22}$	0 0219
89	"	0 0065 [10]	241	C_8H_{18}	0 0157	418	$C_{11}H_{24}$	0 0303	691	$C_{10}H_{22}$	0 0076
90	"	0 0064 [10]	242	"	0 0158	419	"	0 0289	709	$C_{10}H_{22}$	0 0075
91	"	0 0064 [10]	243	"	0 0113	447	$C_{11}H_{24}$	0 00738	721	$C_{10}H_{22}$	0 0076
92	C_8H_{18}	0 0198	245	C_8H_{18}	0 0150 [10]	451	$C_{10}H_{22}$	0 0293	731	$C_{10}H_{22}$	0 0075
93	"	0 0160	287	C_8H_{18}	0 00721	452	"	0 0265 [10]	782	$C_{10}H_{22}$	0 0077

TABLE III

Optical Rotation in Pure Hydrocarbons

Ref no	Formula	Opt rot $[\alpha]_D^{20}$ °	Ref no	Formula	Opt rot $[\alpha]_D^{20}$ °	Ref no	Formula	Opt rot $[\alpha]_D^{20}$ °	Ref no	Formula	Opt rot $[\alpha]_D^{20}$ °
60	C_8H_{18}	+ 39 07°	353b	$C_{10}H_{22}$	46 19°	553	$C_{10}H_{22}$	85 57°	601	$C_{10}H_{22}$	+ 4 36°
120a	C_8H_{18}	1 1 78°	357a	"	1 19 25°	"	"	(-52 8°)	602	"	- 20°
147	C_8H_{18}	1 9 5° [1]	357b	"	- 21 69°	554	"	+ 1 3°	603	"	+ 1 12°
175a	C_8H_{18}	1 9 5°	358a	"	+ 101 89 ⁽¹⁷⁾	555	"	- 101°	604	"	+ 3°
180	"	+ 28 65° to	358b	"	- 84 9° in	556	"	+ 6°	606	"	- 15 2°
	"	- 14 7°	"	"	Either	557	"	- 22 9 ⁽¹⁸⁾	607	"	+ 7 30°
201	C_8H_{18}	+ 4 34°	360a	"	+ 29	558	"	27 9 ⁽¹⁹⁾	608	"	+ 5 36°
222	C_8H_{18}	+ 2 99 ⁽²⁰⁾	360b	"	- 32 12°	559	"	- 36 8°	609	"	+ 2 48°
222a	"	10 85 ⁽²¹⁾	361	"	+ 62 91°	561	"	- 95°	611	$C_{11}H_{24}$	+ 6 3 ⁽²⁰⁾
289	C_8H_{18}	+ 9 38 ⁽²²⁾ [1]	363	"	- 68 76° in	562	"	+ 74 5°	613	"	- 10 12°
292a	"	+ 9 48 ⁽²³⁾ [1]	"	Alc	565	"	- 56 6°	614	"	- 8 8°	
308	$C_{10}H_{22}$	- 74 90°	372a	$C_{10}H_{22}$	1 23 08°	567	"	1 42 73°	622a	$C_{10}H_{22}$	+ 20 24 ⁽²⁴⁾
311	$C_{10}H_{22}$	1 2 66°	372b	"	- 18 9°	568	"	- 38 08°	652b	"	- 4 6 ⁽²⁴⁾
335a	"	+ 51 14°	372c	"	- 16 1°	570a	"	+ 38 72°	757	$C_{11}H_{24}$	- 56 3 ⁽¹⁰⁾ in
335b	"	- 51 28°	373a	"	+ 57 64°	570b	"	- 130°	"	$CHCl_3$	
336	"	- 22 44°	373b	"	47 06°	571	"	- 41°	758	"	+ 64 9 ⁽¹⁰⁾ in
337	"	+ 7 69°	378	"	+ 234° ₁₀₀	572	"	+ 31 36°	"	$CHCl_3$	
338	"	+ 62 2°	379	"	+ 140 77° [19]	573	"	+ 31 36°	759	$C_{11}H_{24}$	+ 24 7° in
339a	"	+ 83 18°	385a	"	+ 8 68°	574	"	- 13 21°	"	$CHCl_3$	
339b	"	68 2°	385b	"	- 8 5° in Alc	576	"	- 26 17°	760	"	+ 25 07 ⁽²⁵⁾ in
345	"	- 112°	386	"	- 18 11°	579	"	- 73 38°	"	$CHCl_3$	
346	"	+ 63 2°	387	"	+ 62 03°	582	"	- 3 34°	773a	$C_{10}H_{22}$	+ 109 48° in
348a	"	+ 126 84°	416	$C_{10}H_{22}$	+ 16 85 ⁽²⁶⁾	583	"	- 41 3°	"	C_6H_6	
348b	"	- 122 5°	440	$C_{11}H_{24}$	- 11°	587	"	- 26 65 ⁽¹⁰⁾ °	773b	"	- 104 9° in
349	"	± 0°	534a	$C_{11}H_{24}$	[liquid]	588	"	- 37 5°	"	C_6H_6	
349	"	- 140 58°	534b	[solid]	595	"	- 12 2°	774	"	+ 112 19° in	
351	"	+ 37 20°	548	$C_{11}H_{24}$	+ 6°	596	"	- 37°	"	C_6H_6	
352	"	+ 110 78°	549	$C_{10}H_{22}$	- 6 1 ⁽²⁷⁾	599	$C_{10}H_{22}$	+ 11 48°	789	$C_{10}H_{22}$	+ 364° in
353a	"	+ 80 17°	551	"	+ 5°	600	"	+ 10 31°	"	C_6H_6	

REFERENCES

1. BEILSTEIN, F. K. *Handbuch der organischen Chemie*
2. BROOKS, B. T. *Non-Benzenoid Hydrocarbons* (Chem. Catalog Co., 1922)
3. COFFIN, C. C., and MAASS, O. *Trans. Roy. Soc. Can.* **21**, 33 (1927)
4. ———. *J. A. C. S.* **50**, 1427 (1928)
5. EDGAR, G., and CALINGAERT, G. *J. A. C. S.* **51**, 1540 (1929)
6. GASCARD, A. *Ann. Chim.* **15**, 332-89 (1921)
7. *Handbook of Chemistry and Physics*, 20th ed. (Chemical Rubber Publishing Co., 1935)
8. HILBRON, I. M. *Dictionary of Organic Compounds*
9. HYMAN, J., and WAINNER, C. R. *J. A. C. S.* **52**, 4346 (1930)
10. *International Critical Tables*, 1st ed. (McGraw-Hill, New York)
11. LUCAS, H. J., and DILLON, R. T. *J. A. C. S.* **50**, 1460 (1928)
12. LUCAS, H. J., DILLON, R. T., and YOUNG, W. G. *J. A. C. S.* **52**, 1952 (1930)
13. MAASS, O., and WRIGHT, C. H. *J. A. C. S.* **43**, 1098 (1921)
14. NORRIS, J. F., and REUTER, R. *J. A. C. S.* **49**, 2633 (1927)
15. PATTERSON, A. M. *J. A. C. S.* **55**, 3905 (1933)
16. RICHTER, V. *Chemistry of the Carbon Compounds*, tr. by Smith, E. F. (P. Blakiston, Son & Co., 1913)
17. ROSSINI, F. D. *Proc. 5th Mid-year Meeting of the American Petroleum Institute*, section III, May 1935, pp. 47-77
18. SHEPARD, A. F., HENNE, A. L., and MIDGLEY, T., JR. *J. A. C. S.* **53**, 1948-58 (1931)
19. SIMONSON, J. L. *The Terpenes*, 1 (Cambridge Press, 1931-2)
20. ———. *J. L. The Terpenes*, 2 (Cambridge Press, 1931-2)

THE PHYSICAL CONSTANTS AND MOLECULAR STRUCTURE OF THE NON-CYCLIC HYDROCARBONS

By CECIL E. BOORD

Professor of Organic Chemistry, Ohio State University

This article deals with the physical constants of the non-cyclic hydrocarbons and more particularly with the relation of these constants to the molecular structure of the simpler paraffins and olefines. Numerous striking relationships have been observed from time to time, but sufficient data has not been at hand to enable one to gain a comprehensive picture of the whole problem. The developments of the last decade in industrial solvents, synthetic plastics, and particularly in gasoline technology have stimulated research on the simple aliphatic compounds. More and more data is becoming available, making it possible to correlate these observations, to point out their utility and the direction in which they might be profitably extended.

The problem in its entirety is wonderfully complex. Just how complex may well be understood by a glance at Table I showing the rapid increase in the theoretically possible number of isomers in the paraffin series as the carbon content is increased.

TABLE I
Number of Paraffin Hydrocarbons [1]

Carbon content	No isomers	Carbon content	No isomers
1	1	8	18
2	1	9	35
3	1	10	75
4	2	12	355
5	3	16	1,858
6	5	18	10,359
7	9	20	366,319

The Normal Paraffins

The changes which occur in the physical constants as one proceeds from member to member in a homologous series have been quite fully investigated. Table II contains typical data for the normal paraffins. It will be noted that the melting-points rise by decreasing increments as the carbon content of the molecule is increased. Upon the basis of melting-points alone the normal paraffins fall naturally into two series, the one containing those hydrocarbons having an odd number, the other an even number of carbon atoms. Beginning with *n*-octane, the rise in the melting-point for each C_nH_{2n} group is almost exactly equal to the corresponding increment in the odd series beginning with nonane.

The boiling-points, densities, and refractivities also rise by gradually decreasing increments, but the separation into odd and even series is no longer apparent. So gradual is the change in the boiling-point interval that many attempts have been made to derive a mathematical formula which will reproduce the experimentally obtained values [2, 1894, 1899; 1904-5, 1913; 1916]. Such formulae yield calculated values agreeing closely with the measured boiling-points except for the lower members of the series. It should be pointed out that they agree well over that region where the composition closely approaches a constant value and deviate in the region where the percentage of carbon and

hydrogen is rapidly changing. Perhaps these deviations from the measured boiling-points and the anomalies in the melting-points find their best explanation in the views of

TABLE II
Normal Paraffins*

Formula	M p, °C*	Differences		B p, °C*	$\Delta B p$
		Even	Odd		
CH ₄	-184.0			-164.0	79.9
C ₂ H ₆	-172.0			-84.1	39.6
C ₃ H ₈		37.0		-44.5	44.4
C ₄ H ₁₀	-135.0		33.7	-0.1	36.1
C ₅ H ₁₂	-130.8	40.7		36.2	32.7
C ₆ H ₁₄	-94.3		33.7	68.9	29.5
C ₇ H ₁₆	-97.1	37.8		98.4	27.4
C ₈ H ₁₈	-56.3		46.1	125.8	23.7
C ₉ H ₂₀	-31.0	24.3		149.5	23.5
C ₁₀ H ₂₂	-32.0		24.5	173.0	21.5
C ₁₁ H ₂₄	-26.5	20.0		194.5	20.0
C ₁₂ H ₂₆	-12.0		20.3	214.5	19.5
C ₁₃ H ₂₈	-6.2	17.5		234.0	28.5
C ₁₄ H ₃₀	5.5		16.2	252.5	18.0
C ₁₅ H ₃₂	10.0	12.5		270.5	17.0
C ₁₆ H ₃₄	18.0		12.5	287.5	15.5
C ₁₇ H ₃₆	22.5	10.0		303.0	14.0
C ₁₈ H ₃₈	28.0		9.5	317.0	13.0
C ₁₉ H ₄₀	32.0	8.7		330.0	
C ₂₀ H ₄₂	36.7		8.4		
C ₂₁ H ₄₄	40.4	7.7			
C ₂₂ H ₄₆	44.4		7.3		

Formula	d_4^{20}	d_4^{25}	n_D^{20}	n_D^{25}	MR _{LL}	MR _{LL} ²
C ₃ H ₈	0.62632	0.63313	1.35769	0.01737	25.26	4.64
C ₄ H ₁₀	0.65945	0.02433	1.37506	0.01269	29.90	4.67
C ₅ H ₁₂	0.68378	0.01901	1.38775	0.00985	34.57	4.62
C ₆ H ₁₄	0.70279	0.01501	1.39760	0.00803	39.19	4.65
C ₇ H ₁₆	0.71780	0.01234	1.40563	0.00640	43.84	4.64
C ₈ H ₁₈	0.73014	0.01011	1.41203	0.00524	48.48	4.63
C ₉ H ₂₀	0.74025	0.00875	1.41727	0.00461	53.11	4.64
C ₁₀ H ₂₂			1.42188		57.75	

* The tabulations for melting-points and boiling-points were taken from Kaufmann, *Beziehungen zwischen physikalischen Eigenschaften und chemischer Konstitution*, pp 135 and 151 (Ferdinand Enke, Stuttgart, 1920).

† Shepard, *Micely and Heine JACS* 53, 1948 (1931)

Mack [12, 1934], who has pointed out that such hydrocarbons are armour plated by hydrogen, the melting- and boiling-points being a function of the van der Waals forces between hydrogen atoms.

The molecular refractivity, a composite function of the density, refractive index, and molecular weight, finds its most commonly accepted expression in the formula by Lorenz and Lorentz [10, 1880],

$$MR_{LL} = \frac{M}{d} \left(\frac{n^2 - 1}{n^2 + 2} \right)$$

Table II shows the function to be a purely additive property, each interval of CH_2 causing a change of 4.64 in the value of the constant. By studying a large number of typical organic compounds, a fixed refractivity may be assigned to each atom by the use of which it is possible to calculate a theoretical value for the molecular refractivity. The value to be assigned depends upon the type of linkage, and corrections must be made for double and triple bonds. This fact has caused Fajans and Knorr [7, 1926] to suggest that the atomic refractivity is more characteristic of the linkage than of the atoms, and should be assigned accordingly. The values most commonly accepted are those of Eschenhuth [5, 1910], who gives the following values when the refractive index has been measured for the sodium D line

Element or linkage	Atomic refractivity
C	2.418
H	1.100
CH_2 (group)	4.618
$>\text{C}=\text{C}<$	1.733
$-\text{C}\equiv\text{C}-$	2.398

The molecular specific heats and molecular volumes for the *n*-paraffins are also additive properties

Branching Chains

In the preceding section the changes in the physical constants were produced by lengthening the chain by one carbon atom or by changing the composition by the increment, CH_2 . Let us now consider the changes produced by isomerization. Table III shows the boiling-point, density, refractive index, molecular volume, and molecular refractivities of the mono- and dimethyl isomers of *n*-heptane and *n*-octane. These constants are expressed as deviations, either positive or negative, from the values for the normal hydrocarbon.

The deviation of the boiling-points of the mono- and dimethyl isomers of *n*-heptane and *n*-octane are all negative in sign. This conforms to the well-known boiling-point rule: *The isomer with the normal carbon chain has the highest boiling-point—the more highly branched the carbon chain the lower the boiling-point.* Methyl groups are most effective in lowering the boiling-point when on the second carbon atom, and become less effective as they are moved towards the centre of the molecule. Two methyl groups on α -carbon atoms cause more than twice the lowering produced by a single methyl group, and the effect is greatest when both are on the same carbon atom [13, 1909]. The second methyl group apparently loses much of its effectiveness when the two are on adjacent carbon atoms.

Edgar and Calingaert [4, 1929], who studied the physical constants of the nine heptanes exhaustively, have pointed out that a methyl group on the second carbon atom tends to decrease the density and refractive index below the normal hydrocarbon, while a methyl group on the third carbon atom tends to increase these constants. It now appears that a methyl group in the 4-position produces a still further increase.

Although the position of the normal hydrocarbon has been displaced to somewhere near the middle of the group, the effect of methyl groups upon the density and refractive index is remarkably like the effect upon the boiling-points. Two methyl groups in the 2-position are more than twice as effective as a single methyl group in the same position, and are most effective when on the same carbon atom. As pointed out by the above authors, two methyl groups upon adjacent carbon atoms show anomaly, the tendency being

to increase both the density and refractive index above the normal hydrocarbon value.

The molecular volume, bearing a reciprocal relation to the density ($MV = M/d$), obviously follows the same order of deviation with a change in sign. Calingaert [3, 1936] has recently presented a graphical method of illustrating these deviations in an effective manner.

The last three columns show the molecular refractivities according to the formulae of Lorenz and Lorentz and Eykman and Nekrassow's constant. The Eykman [6, 1895-6] formula,

$$MRE = \frac{M}{d} \frac{n^2 - 1}{n^2 + 0.4}$$

is believed to be less dependent upon the temperature at which the density and refractivity are measured. Nekrassow's constant [14, 1929],

$$KN = \frac{T \sqrt{MR_{LL}}}{M - MR_{LL}}$$

combines the molecular refractivity, MR_{LL} , with the absolute boiling-point, T . The values are shown as deviations from the constants for the normal hydrocarbons.

These same functions, which are remarkably constant when applied to a large variety of organic compounds, show a definite variation with structure. The isomeric hydrocarbons having methyl groups in the 2-position show a positive deviation roughly proportional to the number of methyl groups so held, while those having methyl groups in the 3- and 4-positions show a negative deviation even greater in degree. While the differences are small, they are so obviously correlated with structure as to leave no doubt as to their validity. Nekrassow's constants show the widest variation, the deviation being roughly proportional to the difference in the boiling-points.

Normal Olefines

The rule is sometimes stated for olefines: *Unsaturated compounds have almost the same boiling-point as the corresponding saturated.* The differences are frequently smaller than the errors of observation [8, 1920].

This rule is no longer true. In part this may be attributed to improvements in the methods of synthesis, but in greater degree it is due to the development of more effective methods of purification. *The normal mono-olefines boil lower than the corresponding saturated hydrocarbons.* The isomer with the double bond in the 2-position has the highest boiling-point, the deviation increasing as the point of unsaturation is moved either towards the middle of the chain or to the 1-position [18, 1934].

The same order of variation has been observed for the normal acetylenes [17, 1931]. *The densities and refractivities of the normal olefines are greater than those of the saturated hydrocarbon.* It is worthy of note that the values for the density and refractive index rise and fall with the boiling-point, the degree and the sign of the deviation being reversed. The 2-olefine shows the highest values (largest deviation), these constants also decreasing as the double bond is moved either towards the middle of the chain or to the 1-position. Acetylenes show this same relative order of variation [17, 1931]. The deviations of the molecular volume of necessity follow those of the density, but with the opposite sign.

The normal fall in the molecular refractivity of a mono-olefine from the value for the corresponding paraffin using

TABLE III
 Isomeric Heptanes
 Monomethylhexenes

Structure	$\Delta B p$	Δd_{4}^{20}	Δn_{D}^{20}	$\Delta M_{j d}$	$\Delta M_{R_{L L}}$	$\Delta M_{R_{H}}$	ΔK_{H}
	-8.4	-0.0047	-0.0027	+1.01	+0.04	+0.03	+0.27
	98.4	0.6836	1.3878	146.47	34.54	75.85	33.28
	-6.6	+0.0034	+0.0010	-0.73	-0.09	-0.21	+0.32
<i>Dimethylpentanes</i>							
	-19.5	0.0099	-0.0055	+2.15	+0.07	+0.09	-1.68
	-17.6	-0.0091	-0.0055	+1.97	+0.05	-0.01	-1.55
	98.4	0.6836	1.3878	146.47	34.54	75.85	33.28
	-12.4	+0.0098	+0.0033	-2.07	-0.23	-0.47	-1.82
	-8.7	+0.0116	+0.0042	-2.45	-0.25	-0.50	-1.75
<i>Isomeric Octanes</i>							
<i>Monomethylheptanes</i>							
	-7.7	-0.0011	-0.0007	+0.26	-0.00	-0.00	-0.66
	125.6	0.7028	1.3976	162.41	39.16	86.11	33.26
	-7.0	+0.0023	+0.0004	-0.53	-0.05	-0.19	-0.64
	-8.6	+0.0062	+0.0016	-0.42	-0.20	-0.41	-1.32
<i>Dimethylhexanes</i>							
	-18.5	-0.0075	-0.0046	+1.74	+0.02	-0.02	-1.52
	-18.1	-0.0064	-0.0031	+1.50	+0.07	+0.16	-1.35
	-15.3	-0.0005	-0.0012	+0.12	-0.07	-0.18	-1.32
	125.6	0.7028	1.3976	162.41	39.16	86.11	33.26
	-13.6	+0.0068	+0.0030	-1.55	-0.12	-0.21	-1.21
	-10.3	+0.0095	+0.0034	-2.20	-0.23	-0.47	-1.03
	-8.9	+0.0094	+0.0043	-2.14	-0.14	-0.26	-0.84

The data used in compiling Tables III, IV, V, VI, VII, VIII, and IX were taken from the following sources

n-Paraffins Shepard, Heone, and Midgely, *JACS* 53, 1948 (1931),

isomeric hexanes Maman, *Compt rend* 198, 1323 (1934),

isomeric heptanes Edgar and Calingaert, *JACS* 51, 1546 (1929)

The data on the isomeric octanes, mono- and diolefines were for the most part taken from measurements made in the Chemistry Laboratories of the Ohio State University during the progress of a survey over these hydrocarbons *JACS* 52, 3396 (1930), 53, 1505 (1931), 54, 751 (1932), 55, 3293 and 4930 (1933). The measurements for the octanes, octenes, and diolefines are from unpublished work.

The data on individual hydrocarbons taken from other sources are indicated in the tables as they occur.

The deviations indicated in the several tables are in all cases between values derived from actual measurements. In a few cases these deviations are less than the experimental error.

TABLE IV
The Normal Olefines

Structure	ΔB_p (760)	Δd^{20}	Δn_D^{20}	$\Delta M/d^{20}$	ΔMR_{LL}	ΔMR_E	ΔK_E
C-C-C-C-C	68 71	0 65945	1 37506	130 57	29 90	65 52	33 24
C-C-C-C-C*	-0 7	+0 0317	+0 0177	-7 14	-0 46	-0 82	+0 61
C-C-C-C-C†	-1 9	+0 0320	+0 0191	-7 19	-0 38	-0 63	+0 59
C-C-C-C-C‡	-5 2	+0 0236	+0 0107	-5 65	-0 57	-1 13	+0 03
C-C-C-C-C-C	98 4	0 6838	1 3878	146 47	34 54	75 85	33 27
C-C-C-C-C-C*	-0 15	+0 0198	+0 0163	-7 13	-0 46	-0 83	+0 58
C-C-C-C-C-C†	-3 1	+0 0161	+0 0170	-6 25	-0 19	-0 23	+0 73
C-C-C-C-C-C‡	-3 5	+0 0157	+0 0121	-6 17	-0 54	-1 05	+0 19
C-C-C-C-C-C-C	125 6	0 7028	1 3976	162 41	39 16	86 13	33 26
C-C-C-C-C-C-C*	-0 5	+0 0197	+0 0173	-7 22	-0 31	-0 12	+0 70
C-C-C-C-C-C-C†	-2 8	+0 0157	+0 0162	-6 35	-0 18	-0 20	+0 52
C-C-C-C-C-C-C‡	-3 45	+0 0156	+0 0164	-6 33	-0 16	+0 62	+0 77
C-C-C-C-C-C-C-C	-4 55	+0 0123	+0 0114	-5 61	-0 44	-0 72	+0 18

Eisenlhr's values is -0.467 . Table IV shows the molecular refractivities of the straight-chain olefines to be approximately normal when the point of unsaturation is in the 1- or 2-position, but the deviation decreases rapidly as the double bond is moved towards the middle of the chain. This fact seems significant in view of the findings of Lovell, Campbell, and Boyd [11, 1931], who have shown the ant-knock value of an unsaturated hydrocarbon to be a function of length of the saturated chain. The Nekrassov constants are in every case higher than for the corresponding saturated hydrocarbon.

Normal Diolefines

The physical constants of the normal dienes are shown in Table V in comparison with those of the normal paraffins. Among the penta-dienes and hexa-dienes the isomers having the double bonds in the 1, 1' positions have the lowest boiling-points, and the boiling-points rise as the double bonds approach each other or are moved towards the

middle of the chain. The dienes having the double bonds 'conjugated' or 'cumulated' boil higher than the normal paraffin. On the other hand, double bonds in the 'isolated' positions act independently and approximately additively.

The densities and refractivities of the normal dienes are higher than the same constants for the corresponding mono-olefines or saturated hydrocarbons. The refractive indices of the conjugated diolefines are abnormally high, a fact which is reflected in the 'exaltation' of their molecular refractivity.

Branched Olefines

In the preceding section the effect of branching the chain or of introducing the double bond upon the physical constants have been reviewed in comparison with the same constants for the normal saturated hydrocarbons. Let us now consider the more usual case where both factors are present in the same molecule. Mono-olefines fall naturally into five types, depending upon the number of alkyl groups

TABLE V
Some Normal Diolefines

Structure	ΔB_p (760)	Δd^{20}	Δn_D^{20}	$\Delta M/d^{20}$	ΔMR_{LL}	ΔMR_E	ΔK_E
C-C-C-C-C	36 0	0 62632	1 35769	115 11	25 26	55 22	33 15
C-C-C-C-C*	+15 0	+0 0761					
C-C-C-C-C†	+9 0	+0 063	+0 0572	-16 32	-0 53	-0 69	+3 34
C-C-C-C-C‡	+7 0	+0 059	+0 0732	-15 75	-0 05	+1 62	+4 69
C-C-C-C-C-C	-10 0	+0 0331	+0 0306	-11 89	-0 89	-1 70	+0 63
C-C-C-C-C-C	68 71	0 65945	1 37506	130 57	29 90	65 52	33 24
C-C-C-C-C-C*	+11 3	+0 061	+0 0763	-16 57	+0 82	+2 61	+4 85
C-C-C-C-C-C†	+10 3	+0 0603	+0 0547	-16 54	-0 46	-0 45	+3 05
C-C-C-C-C-C‡	+4 8	+0 0557	+0 0665	-15 80	+0 44	+1 67	+3 75
C-C-C-C-C-C-C	-4 3	+0 0401	+0 0411	-13 25	-0 45	-0 57	+1 66
C-C-C-C-C-C-C*	-9 1	+0 0325	+0 0293	-11 96	-0 87	-1 61	+0 35
C-C-C-C-C-C-C	98 4	0 6838	1 3878	146 6	34 54	75 85	33 27
C-C-C-C-C-C-C*	+6 6	+0 0505	+0 0624	-15 45	+0 61	+2 07	+3 50
C-C-C-C-C-C-C†	+7 1	+0 0468	+0 0444	-15 07	-0 41	-0 40	+2 41
C-C-C-C-C-C-C‡	-6 3	+0 0338	+0 0324	-12 7	-0 64	-1 04	+0 91
C-C-C-C-C-C-C-C	-4 2	+0 0444	+0 0318	-14 6	-1 17	-2 23	+0 53
C-C-C-C-C-C-C-C	125 6	0 7028	1 3976	162 41	39 16	86 11	33 26
C-C-C-C-C-C-C-C*	+13 4						
C-C-C-C-C-C-C-C†	-0 6	+0 0053	+0 0028	-6 91	-1 43	-3 11	+0 52
C-C-C-C-C-C-C-C‡	-6 1	+0 0297	+0 0269	-12 09	-0 76	-1 32	+0 64
C-C-C-C-C-C-C-C-C	-7 8	+0 0286	+0 0289	-11 86	-0 55	-0 81	+0 71

* Kurkutschin *J Russ Phy Chem Soc.* 35, 873 (1903).

† Bouis *Ann chim* (10), 9, 402 (1929).

‡ Auwers and Westerman *Ber* 54 n, 2993 (1921)

§ Id. Loc. cit.

|| Bouis. Loc. cit.

¶ Provost *Ann chim* (10) 16, 113 (1931).

** Auwers and Westerman *Ber* 54, n 2998 (1921).

†† Bouis. Loc. cit.

‡‡ Charon *Ann chim* (7) 17, 265 (1898)

§§ van Rinsbergen *Bull soc Belg* 39, 549 (1930)

PHYSICAL CONSTANTS AND MOLECULAR STRUCTURE OF NON-CYCLIC HYDROCARBONS 1353

attached to the unsaturated carbon atoms. For simplicity in discussion we have designated these as I, II, III, IV, and V as indicated by the typical structures below

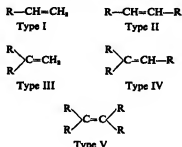

In Table VI are listed the olefine derivatives of three branched paraffins. The olefines in each group are arranged in a descending order by type. In order to avoid the confusion of two superimposed effects, the comparisons have been made with the paraffin having the same arrangement

of carbon atoms and of which they may be regarded as derivatives

The boiling-points, densities, and refractivities will be seen to stand in the same order as their type. The olefines of types I and II boil lower than the parent paraffin, the different members of type II being arranged in the same order as the normal olefines. The olefines of the higher types as a rule boil higher than the saturated hydrocarbon, the deviation for the type III derivative being very small. These facts stand in agreement to the observation by Pawlow [15, 1879], who says, 'The accumulation of methyl groups in hydrocarbons of the ethylene series seems to be able to raise the boiling temperature'. The rule is better stated: *The accumulation of methyl groups on the unsaturated carbon atoms of an olefine tends to raise the boiling-point* [16, 1932]. In nineteen such groups arranged in the author's laboratory and for which acceptable data was available on all members of the group, the order by type was found to hold without exception.

The branched chain rule still holds, however, when the

TABLE VI
Branched Olefines

Structure	Type	ΔB_p	Δd_4^{20}	Δn_D^{20}	$\Delta M/d$	ΔMR_{LL}	ΔMR_R	ΔK_R
		60.2	0.6508	1.3744	132.31	30.24	66.28	32.82
	IV	+7.15	+0.0396	+0.0261	-10.5	-0.68	-1.24	+1.11
	III	+1.55	+0.0309	+0.0177	-8.95	-0.86	-1.72	+1.34
	II	-2.1	+0.0201	+0.0141	-6.96	-0.63	-1.25	+0.24
	I	-6.45	+0.0138	+0.0081	-5.87	-0.76	-1.99	-0.32
		90.0	0.6789	1.3851	147.48	34.56	75.88	32.55
	IV	+4.5	+0.0300	+0.0224	-9.08	-0.46	-0.77	+0.97
	III	+1.25	+0.0211	+0.0189	-7.32	-0.28	-0.43	+0.86
	II	+1.35	+0.0201	+0.0139	-7.12	-0.62	-1.20	+0.52
	II	-3.15	+0.0153	+0.0140	-6.15	-0.37	-0.67	+0.40
	I	-5.3	+0.0147	+0.0103	-6.03	-0.62	-1.27	+0.08
		78.9	0.6737	1.3823	148.62	34.61	75.94	31.60
	II	-2.8	+0.0144	+0.0163	-6.04	-0.15	-0.16	+0.56
	I	-7.3	+0.0087	+0.0109	-4.85	-0.28	-0.50	+0.05

branching is confined to the alkyl group. Table VII shows the differential values for the unsymmetrical dipropylethylenes and the derivatives of 2,3-dimethylpentane. When the alkyl group is highly branched on the carbon atom adjacent to the double bond, as in the case of di-isopropylethylene, the branching causes an abnormal lowering of the boiling-point. The derivatives of 2,3-dimethylpentane, indeed, show a marked disarrangement of the order of types.

Perhaps we have here the essence of the many anomalies

carbon skeleton. It will be seen that the depression of the boiling-point increases as the branching of the alkyl group is moved towards the double bond. The greater the degree of branching and the closer the branching to the point of unsaturation the larger the deviation.

The density and the refractive index also follow the branching of the chain. When the degree of branching is high and close to the point of unsaturation the deviation is small. As the branching recedes down the chain the deviation increases and is greatest for the normal hydrocarbon.

TABLE VII
Dipropylethylenes of Type III

Structure	Type	ΔB_p	Δd_p°	Δn_D^{20}	$\Delta M/d$	ΔMR_{LL}	ΔMR_R	ΔK_R
	III	-0.7	+0.0150	+0.0144	-6.19	-0.29	-0.48	+0.70
	III	-3.45	+0.0088	+0.0107	-4.75	-0.27	-0.45	+0.35
	III	-9.75	+0.0002	+0.0059	-2.86	-0.21	-0.38	-0.14
<i>Derivatives of 2,3-Dimethylpentane</i>								
		89.7	0.6952	1.3920	144.02	34.29	75.35	32.27
	V	+2.1	+0.0251	+0.0230	-7.82	-0.19	-0.16	+1.00
	IV	-3.4	+0.0174	+0.0132	-6.35	-0.53	-1.04	+0.17
	III	+0.8	+0.0234	+0.0200	-7.49	-0.32	-0.48	+0.61
	III	-5.5	+0.0102	+0.0102	-4.94	-0.41	-0.80	+0.10
	I	-9.3	+0.0054	+0.0069	-3.99	-0.43	-0.87	-0.71

observed in the physical constants of the hydrocarbons having side chains on adjacent carbon atoms. The anomalous densities and refractivities of certain heptanes, as pointed out by Edgar and Calingaert, have been cited above. Levene and Marker [9, 1933] also found optically active hydrocarbons, containing an isopropyl group attached directly to the asymmetric carbon atom to show an anomalous rotation. Furthermore, Wakemann, as will be pointed out below, in formulating a series of additive values to be used in calculating the boiling-points of paraffins, olefins, and acetylenes, found it necessary to separate the functional groups at least by one methylene group.

Isomeric Olefins of Type I

In the simple case of the olefine derivatives of a paraffin having a single side chain we have seen how the physical constants follow the order of the olefine type. Exceptions were found among the derivatives of those paraffins having branches on adjacent carbon atoms. And an abnormal lowering of the boiling-point was observed when the alkyl group was highly branched on the carbon atom alpha to the double bond. Let us now consider a group of isomers of the same type. In Table VIII are listed the hexenes and heptenes of type I. The comparisons have been made in each case with the saturated hydrocarbon having the same

The molecular refractivity is not far from normal, but the deviation from the parent hydrocarbon becomes smaller the deeper the unsaturation is buried in the molecule.

Theoretical Discussion

Having before us a series of cross-sectional views of the parallelism between the physical constants and the molecular structure, let us now consider the theoretical aspect of the problem. The atomic nuclei and extra-nuclear electrons of the normal paraffin molecule must form an electrical electric field of force which is comparatively uniform and free from strain. Such a view stands in good agreement with the high stability and low chemical reactivity of these hydrocarbons. When the molecule is isomerized, by the branching of the chain, or is unsaturated, by the introduction of a double bond, points of non-uniformity or strain are developed. These changes are reflected in the altered physical constants of the compound and in increased chemical reactivity.

The question as to how far this disturbance or strain extends over the molecular structure cannot be fully answered at the present time. The influence is marked on the carbon atom adjacent to the functional group. Hence the anomaly in the physical constants of 2,3-dimethylpentane, the abnormally low boiling-point of unsymmetrical di-isopropylethylene, and the high refractive indices

TABLE VIII
 Olefines of Type I
 Hexenes

Structure	ΔB_p	Δd_4^{20}	Δn_D^{20}	$\Delta M/d$	ΔMR_{LL}	ΔMR_R	ΔK_T
<chem>C=C-C-C-C=C</chem>	-5.16	+0.0137	+0.0107	-5.66	-0.58	-2.99	-0.03
<chem>C=C-C-C-C=C</chem>	-6.75	+0.0127	+0.0108	-5.55	-0.51	-1.59	+0.04
<chem>C=C-C-C=C</chem>	-8.9	+0.0086	+0.0072	-4.67	-0.57	-1.20	-0.33
<chem>C=C-C=C</chem>	-11.4	-0.0008	+0.0054	-2.93	-0.28	-0.58	-1.39
Heptenes							
<chem>C=C-C-C-C-C=C</chem>	-3.5	+0.0157	+0.0121	-6.17	-0.54	-1.05	+0.19
<chem>C=C-C-C-C=C</chem>	-5.3	+0.0147	+0.0103	-6.03	-0.62	-1.27	+0.08
<chem>C=C-C-C-C=C</chem>	-4.45	+0.0099	+0.0098	-4.96	-0.46	-0.83	+0.15
<chem>C=C-C-C=C</chem>	-7.3	+0.0087	+0.0109	-4.85	-0.28	-0.20	+0.05
<chem>C=C-C-C-C=C</chem>	-7.9	+0.0083	+0.0083	-4.64	-0.47	-0.93	-0.17
<chem>C=C-C-C-C=C</chem>	-9.3	+0.0054	+0.0069	-3.99	-0.43	-0.89	-0.71
<chem>C=C-C-C-C=C</chem>	-9.1	+0.0027	+0.0080	-3.46	-0.22	-0.38	-0.05
<chem>C=C-C-C-C=C</chem>	-9.8	+0.0028	+0.0061	-2.32	-0.09	-0.13	+0.02

of diolefines containing conjugated double bonds. The abnormality in compounds containing conjugated double bonds has long been recognized. It manifests itself both chemically and physically, in the former case by 1-4 addition at the double bond and in the latter by an 'exaltation' of the molecular refractivity. Perhaps from our present point of view one would be equally justified in speaking of conjugated methyl groups or of a methyl group being conjugate to a double bond.

How far two functional groups must be separated before their action is wholly independent is not known. The deviation of the physical constants of the 1,5-diolefines

from the corresponding normal paraffin seem nearly additive, but the experimentally determined values are persistently greater than those calculated on an assumption of strict additivity. More and better data must be obtained before a final answer can be given to the question.

Utility

Wakemann [18, 1934] has recently proposed a series of values or weightings for methyl groups, double and triple bonds to be used in calculating the boiling-points of unknown hydrocarbons. The weightings are admittedly approximate and based on the assumption that the boiling-

 TABLE IX
 Additivity of Properties

Structure	ΔB_p	Δd_4	Δn_D^{20}	$\Delta M/d$	ΔMR_{LL}	ΔMR_R	ΔK_T
<chem>C-C-C-C-C-C-C</chem>	98.38	0.6838	1.3878	146.47	34.54	75.85	33.27
<chem>C=C-C-C-C-C-C</chem>	-3.48	+0.0155	+0.0121	-6.17	-0.54	-1.05	+0.19
<chem>C-C=C-C-C-C-C</chem>	-0.15	+0.0196	+0.0163	-7.13	-0.46	-0.83	+0.58
Summation	-3.63	+0.0351	+0.0284	-13.30	-1.00	-1.88	+0.77
<chem>C=C-C-C-C-C-C</chem>	-4.18	+0.0444	+0.0318	-14.51	-1.16	-2.23	+0.54
<chem>C-C-C-C-C-C-C-C</chem>	125.59	0.7028	1.3976	162.41	39.16	86.13	33.26
<chem>C=C-C-C-C-C-C-C</chem>	-4.55	+0.0123	+0.0114	-5.61	-0.39	0.72	+0.18
<chem>C-C=C-C-C-C-C-C</chem>	-2.79	+0.0157	+0.0162	-6.36	-0.19	-0.20	+0.51
Summation	-7.34	+0.0280	+0.0276	-11.97	-0.58	-0.92	+0.69
<chem>C=C-C-C-C-C-C-C</chem>	-7.74	+0.0286	+0.0289	-11.86	-0.53	-3.15	+0.67

point curves for a series of compounds containing the same functional group run parallel. This assumption perhaps is not justified if the weightings are to be used over any extended range. Further, it is essential for the several functional groups to be sufficiently isolated so that their fields of influence do not overlap.

A more general method of comparison is illustrated in Tables III to IX inclusive. If the physical constants for any one or more members of a group of derivatives containing the same carbon skeleton are accurately known, other members of the same group must fall above, between, or below these values in their proper order. The comparisons are applicable not only to boiling-points, but to densities, molecular volumes, and refractive indices equally well. Compounds containing two functional groups as a methyl group and a double bond or two double bonds fall into their proper place. Compounds containing two methyl groups or multiple functions must receive further study before their order can be fixed with certainty.

Such comparisons have great utility. They may be used to discover error in physical constants recorded in the literature, or to select the most probable from a series of discordant values. They may also be used to test the validity of one's own work. In any such application it must be remembered the rules will be extended, and that as the molecule becomes more complex new exceptions will be found.

The unsaturated derivatives in any given group upon hydrogenation yield the same paraffin. By this simple process any new product may be readily identified with its

own group. Its physical constants fix its position within the group. Such comparisons are therefore useful in determining the validity of the structure to be assigned. Much of the error in the literature is not the result of poor technique, but rather due to a mistaken identity in the compound in hand.

The petroleum chemist has been frequently asked, "What is in a gallon of gasoline?" There has been no definite answer to this question. A gallon of gasoline is a complex mixture which may contain any of several hundred different hydrocarbons. Gasoline produced on different runs, and certainly gasolines produced from different crudes, seldom have precisely the same composition.

The ever-increasing demands for motor fuels has necessitated the introduction of cracking methods in our refinery practice. Higher compression ratios have called for "reforming processes" to improve the octane rating of the product. Now comes "polymerization gasoline" with the ultimate possibility of a motor fuel having a rating equal to 100% octane. Slowly but surely the range of what may be contained in a gallon of gasoline is being confined to ever narrower limits. The petroleum chemist may see before him as an ultimate goal a chemically pure motor fuel containing a single, individual hydrocarbon. It may be years before this goal is achieved, but the forward-looking technologist must know which molecular structure gives the highest anti-knock rating, the greatest power, the best engine performance. Our knowledge of the non-cyclic hydrocarbons and the relation of their physical and chemical characteristics must of necessity be greatly extended.

REFERENCES

- BLAIR, C. M., and HENZE, H. R. *J. A. C. S.* 53, 3084 (1931)
- BOGGS-LEA, E. *Gazz.* 29, 1, 441 (1899)
- WALKER, J. *J. C. S.* 65, 193 (1894)
- RAMAGE, H. *Proc. Camb. Phil. Soc.* 12, v, 445 (1904)
- YOUNG, S. *Phil. Mag.* (6) 9, 1 (1905)
- SUDDEN, S. *Chem. News*, 107, 135 (1913)
- FLUMMER, H. C. *Phil. Mag.* 6, 32, 371 (1916)
- CALINGAERT, G., and HLADEK, J. W. *J. A. C. S.* 58, 153 (1936)
- EDGAR, G., and CALINGAERT, G. *J. A. C. S.* 51, 1540 (1929)
- EBENLOH, F. *Z. Physik. Chem.* 75, 585 (1910)
- EYKMAN, J. F. *Rec. trav. chim.* 14, 185 (1895), 15, 52 (1896)
- FAJANS, K., and KNOER, C. A. *Ber.* 59, 256 (1926)
- KAUFMANN, C. E. *Beziehungen zwischen physikalischen Eigenschaften und chemischer Konstitution*, 165-6 (Ferdinand Enke, Stuttgart, 1920)
- LYEENS, P. A., and MARKER, R. E. *J. Biol. Chem.* 101, 413 (1933)
- LORENZ and LORENZ. *Wied. Annalen*, 9, 641, 11, 70 (1880)
- LOVELL, W. G., CAMPBELL, J. M., and BOYD, T. A. *Ind. Eng. Chem.* 23, 557 (1931)
- MACK, EDWARD, JR. *J. A. C. S.* 56, 2757 (1934)
- MENSCHUTKEN, B. N. *Chem. News*, 100, 293 (1909)
- NEKRANOW, B. *Z. Physik. Chem.* A, 140, 344 (1929)
- PAWLOW, D. *Ann.* 196, 126 (1879)
- SCHMITT, C. G., and BOORD, C. E. *J. A. C. S.* 54, 755 (1932)
- TRUCHET, R. *Ann. chim.* [10] 16, 402 (1931)
- WALKERMAN, R. L. *Rec. trav. chim.* 53, 832 (1934)

THE ENERGY OF ATOMIC LINKAGES IN HYDROCARBONS

By J. P. WIBAUT, D.Sc.

Professor of Organic Chemistry, University of Amsterdam

§ 1. Introduction

The molecular heats of combustion of homologous hydrocarbons in the gaseous state show nearly constant differences between successive members of the series, the increase for each CH_2 group in the paraffin series is about 157 kg-cal, if the first members CH_4 and C_2H_6 are disregarded. Therefore the heats of formation from gaseous atoms in a series of homologous hydrocarbons may be calculated on the assumption that the energies for the C-C linkages and for the C-H linkages are practically constant for all the hydrocarbons of a homologous series (Thomsen [23, 1886], Fajans [2, 1920], Pauling [13, 1932]).

However, the assumption that the energies of atomic linkages are practically constant is not in accordance with the facts, even in the series of the normal paraffins. F. D. Rossini [17, 1934] concludes from very accurate determinations of the heats of combustion of the hydrocarbons CH_4 , C_2H_6 , C_3H_8 and of the normal paraffins C_4H_{10} , C_5H_{12} , C_6H_{14} , C_7H_{16} , C_8H_{18} , that the molecular heat of combustion of a paraffin $\text{C}_n\text{H}_{2n+2}$ can be represented by the function $60.40 + n(157.00 \pm 0.08)$ kg-cal for values of $n > 5$ but not for values of $n < 5$. The difference between the molecular heats of combustion of CH_4 and C_2H_6 is 160.02 kg-cal, that between C_2H_6 and C_3H_8 is 157.76 kg-cal. The conclusion of Rossini is that the energies of the atomic linkages in normal paraffin hydrocarbons are appreciably affected by the nature of the substituents, hydrogen atoms or alkyl groups, the bonds at the ends of the normal paraffin molecules are considered to be different from the other bonds. Within the accuracy of the experimental data there is no interaction with regard to energy between CH_2 groups that are separated by two or more carbon atoms. For example, the methyl group at the end of the chain of carbon atoms has a sphere of influence that includes the CH_2 group twice removed from it.

With regard to the paraffin hydrocarbons with branched chains there is some experimental evidence that the heats of combustion of paraffins with branched chains are slightly different from the heats of combustion of the isomeric normal hydrocarbons, which would mean that the energies of the C-C linkages and C-H linkages are different when branched chains are considered (compare K. Fajans [4, 1921]). The deviations are, however, small, and in the case of isomeric heptanes and isomeric octanes the differences in the heats of combustion of isomerides are of the same order of magnitude as the experimental errors (Richards and Jesse [16], Kharasch [7]).

There are some indications from spectroscopical investigations that the energies of linkages in paraffin hydrocarbons are not constant. For instance, Brackett [1, 1928] deduced from infra-red adsorption spectra of liquid paraffin hydrocarbons that the binding force of a primary C-H linkage is greater than that of a secondary C-H linkage by about 3.2% and greater than that of tertiary C-H linkages by about 5.6%. It seems that further development of spectroscopical methods has to be awaited before it can be decided if such differences can be calculated within that degree of accuracy.

It has been shown by Fajans [2] that the absolute values of the energies of C-C bonds and of C-H bonds can be computed from the heats of combustion of the hydrocarbons, if the heat of dissociation of a hydrogen molecule into hydrogen atoms and the heat of volatilization of solid carbon into gaseous carbon atoms are known.

In the following calculations the heat of dissociation of molecular hydrogen is taken to be 102 kg-cal [9]. The heat of volatilization of solid carbon to carbon atoms has been determined approximately (Kohn and Guckel [8, 1920]; Fajans [3, 1925]), as the most probable value at the ordinary temperature 150 kg-cal has been assumed by different investigators.

In order to show the nature of the calculations an example is given. The heat of combustion of solid carbon to gaseous carbon dioxide is 94.4 kg-cal. If the heat of volatilization of solid carbon is assumed to be 150 kg-cal, the heat of combustion of gaseous carbon atoms is equal to 244 kg-cal per gram atom. As the heat of combustion of gaseous molecular hydrogen to liquid water is 68.4 kg-cal and the heat of dissociation of a hydrogen molecule into hydrogen atoms is 102 kg-cal, the heat of combustion of hydrogen atoms to liquid water amounts to 85 kg-cal per gram atom. If the energy of C-H linkages is called x and the energy of C-C linkages is called y , the heat of combustion of a paraffin $\text{C}_n\text{H}_{2n+2}$ in the gaseous state can be represented as follows

$$-(2n+2)x - (n-1)y + nz + (2n+2)v = \text{heat of combustion}$$

From the equations for two successive members of the paraffin series, the following equations are found

$$z - 2y = A, \quad -y - 2x + z + 2v = B$$

From the heats of combustion of normal paraffins, containing more than five carbon atoms, the value of A is found to be 96.6 kg-cal and the value of B 157.0 kg-cal. Therefore the values of the C-C linkages and of the C-H linkages in this group of hydrocarbons are given by $y = 73.7$, $x = 91.7$.

If the lower members of the paraffin series are considered, somewhat different values are found, from the heat of combustion of CH_4 the value of x is found to be 93, while a value of $y = 68$ is calculated from the heats of combustion of CH_4 and C_2H_6 . From C_2H_6 , C_3H_8 , and C_4H_{10} values for y between 72 and 72.8 are found.

If the heats of combustion of paraffin hydrocarbons with branched chains and containing 4-6 carbon atoms were exactly known, it might be that the values for x and y would appear slightly different from the values which are valid for the higher normal paraffins. Therefore it should be kept in mind that the values for the C-C linkages $y = 73$ and for the C-H linkages $x = 92$, which are used in the following, represent mean values and that there may exist deviations of different values, depending on the group of hydrocarbons which is considered.

From the heats of combustion only relative values for the energies of the atomic linkages can be found. It has been pointed out that for the calculation of the absolute

values the heat of volatilization of solid carbon and the heat of dissociation of molecular hydrogen are required. As the heat of volatilization of solid carbon can only be estimated to a rough degree of approximation, the uncertainty involved in the absolute values of the energies of the C-C linkages and of the C-H linkages is much greater than the deviations from constancy in different hydrocarbons.

A correction of another kind for the absolute values of the energies of atomic linkages has been suggested by R. G. W. Norrish [12, 1934], compare also R. Mecke [11, 1930]. The reasoning of Norrish is the following. It is concluded from spectroscopical investigations that a gaseous carbon atom may exist in two forms—chemically divalent and tetravalent respectively—which are referred to as the 3P and 1S states. The energy difference between these forms has been approximately estimated at about 37 kg.-cal. It is assumed that gaseous carbon exists in the 3P (divalent) state, while the imaginary dissociation of the organic molecules into atoms should lead to a carbon atom in the 1S (tetravalent) state.

The value of the C-H linkages as computed from the heat of combustion of methane is 93 kg.-cal. This means that if the four hydrogen atoms are removed from methane and the resulting tetravalent carbon atom is allowed to change to the divalent condition, $4 \times 93 = 372$ kg.-cal will be absorbed. The heat of rupture of a single H-atom to leave a CH_3 group must be adjusted for the energy when carbon passes from the tetravalent to the divalent condition, the value of the C-H bond is therefore $(372+37)/4 = 102$ kg.-cal. Here it is assumed that the successive detachment of the hydrogen atoms involves energy steps of the same magnitude.

As the energy difference between the 3P state and the 1S state of gaseous carbon is not exactly known, this involves another uncertainty with regard to the absolute values of the energies of atomic linkages of carbon compounds. If the energy of dissociation of gaseous carbon monoxide into gaseous atoms could be measured exactly, it would be possible to calculate exact values for the energies of dissociation of hydrocarbon molecules into gaseous normal carbon and hydrogen atoms (Rossini [17, 1934]). The uncertainty in the absolute values is therefore much greater than the deviations from constancy of the linkage energies in paraffins.

§2. The Values of the Energies of Atomic Linkages in Different Classes of Hydrocarbons

The value of the energy of the double bond C=C can be computed from the heats of combustion of olefinic hydrocarbons, in the same manner as in §1 for the paraffins (K. Fajans [2, 1920, 1922], J. P. Wibaut [24, 1922]). Here, again, it is assumed that the heats of all the C-C linkages and of all the C-H linkages in olefinic hydrocarbons are constant and that the value for the single C-C bond in olefines is the same as for the single C-C bond in paraffins. The mean value of the double bond is then found to be 128 kg.-cal.

In the same manner, the mean value of the energy of the triple bond C=C in hydrocarbons of the acetylene series is computed to be about 170 kg.-cal.

These figures only represent a rough approximation, as it does not seem probable that the heat of a C-H linkage in HC=CH will be exactly the same as the heat of the C-H linkages of the CH_3 group in HC=C CH_3 .

It is neither probable that all the C-H linkages in propylene—nor higher olefines—have exactly the same energy values.

Moreover, the experimental data on which the calculation of the energy value of the double bond is based are partly the heats of combustion of the lower olefines containing 2-5 carbon atoms which have been determined by J. Thomsen [23, 1886]. The value obtained for the energy of the double bond obtained from these data show considerable fluctuations. In the case of the hydrocarbons of the acetylene series the experimental data are very scanty and the accuracy is less than in modern measurements of the heat of combustion of the paraffins.

Cycloparaffins C_nH_{2n} . The heats of combustion of cycloparaffins containing 5 or more C-atoms in the ring are approximately additive, the increment per CH_2 group is about 157 kg.-cal (compare the experimental data of Zubov, summarized by Swientowski [22, 1920]), heats of combustion of cycloparaffins containing 8, 15, 17, and 30 C-atoms in the ring have been determined by Rucicka and Schlapfer [19] (1933).

It is to be noted that the heat of combustion does not reveal the existence of any 'strain' in the ring of this class of hydrocarbons when rings of 5 up to 30 carbon atoms are considered. Therefore it may be assumed that the energies of C-H linkages and of C-C linkages in the cycloparaffins containing 5 or more C-atoms in the ring are approximately constant within the same degree of approximation as in the paraffin series. The same holds for the linkages of side chains in hydrocarbons of the cycloparaffins series.

Aromatic Hydrocarbons. It is neither possible by calculations of the kind used for the computation of the energies of atomic linkages from heats of combustion to decide whether single bonds and double bonds are present in an aromatic nucleus, nor can the heats of these kinds of bonds be calculated separately (Wibaut [25, 1922]). If it is assumed that the benzene molecule contains 6 and the naphthalene molecule 11 C-C bonds, a value of 97 kg.-cal per C-C bond is calculated from the heats of combustion of gaseous benzene and of gaseous naphthalene. The heat of the C-H linkage in benzene and naphthalene is then found to be 100 kg.-cal. The same values are found from benzene and diphenyl.

However, it must be assumed from static considerations of structure that the benzene molecule contains 3 single C-C bonds and 3 double C=C bonds, while the naphthalene molecule contains 6 single bonds and 5 double bonds, the figure of 97 kg.-cal for the C-C bond in aromatic rings therefore indicates only the mean value per carbon atom of the two kinds of carbon linkages in the aromatic nucleus. If it is assumed that the energy of the single C-C bond in aromatic rings has the same value as in paraffin hydrocarbons the energy of the C=C linkage in the benzene nucleus is 121 kg.-cal, which is not very different from the C=C linkage in olefines.

If it is assumed that the value of the C-H bond in the side chains of methylbenzenes is 93 kg.-cal, while for the mean value of the C-C bond in the nucleus 97 kg.-cal is taken and for the C-H bond in the nucleus 100 kg.-cal, then the value of the C-C linkage between the nucleus and the methyl group may be calculated, for instance, from the heats of combustion of toluene and of *m*-xylene it is found to be 83 kg.-cal. The same value for the linkage $C_{aromatic}-C_{aliphatic}$ is found from the heats of combustion of benzene, toluene, and methane, provided it is assumed that

the C-H linkages in the methyl group of toluene have the same energy values as in methane

If an unsaturated cycloparaffin like cyclohexene is considered, it may be assumed that the 10 C-H linkages in this hydrocarbon are of aliphatic character, the energy of the C=C linkages is then found to be 128 kg-cal. However, assuming that cyclohexene contains 8 aliphatic C-H and 2 aromatic C-H linkages, the value of the C=C linking is 112 kg-cal. Therefore the energies of atomic linkages in tetrahydrobenzene, dihydrobenzene, and their homologues cannot be calculated without additional assumptions. This is clearly shown by the following heats of reaction

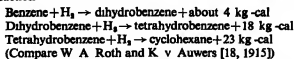

It follows from these figures that there exist differences in the energies of atomic linkages when dihydrobenzene is compared with tetrahydrobenzene, but it is not possible to calculate energies of atomic linkages in either of these hydrocarbons

The mean values of the energies of atomic linkages in hydrocarbons are summarized in the following table (compare also Grimm [5, 1926], Sidgwick and Bowen [21, 1931])

Linkage	Energy of linkage in kg-cal
C-C	73
C-H	92
C=C	128
C≡C	About 170

In aromatic rings, when for C-C the same value is assumed as in paraffins

Linkage	Energy of linkage in kg-cal
C-H	100
C-C	73
C=C	121

Mean value of C-C bonds per carbon atom
in the aromatic nucleus 97
 $C_{arom} - C_{aliph}$ 85

If the adjustment suggested by Norrish [12, 1934] is applied to these values, the following figures are obtained

Linkage	Energy of linkage in kg-cal
C-H in paraffins	$92 + \frac{37}{4} = 101$
C-C in paraffins	$73 + \frac{37}{2} = 91$
C=C in olefines	$128 + 37 = 165$
C≡C in acetylenes	$170 + \frac{3}{2} \times 37 = 225$

§ 3. Physical Meaning of Energies of Atomic Linkages

The energies of linkages as defined in the preceding sections have the significance of arithmetical magnitudes. For instance, if it is stated that the energy of a C-H linking in methane is 93 kg-cal, this means that the energy required for the dissociation of a gram molecule of methane into 4 gram atoms of gaseous hydrogen and 1 gram atom of gaseous (divalent) carbon amounts to 4×93 kg-cal. It does not follow, however, that the energy required to separate one H atom from CH_4 , leaving gaseous CH_3 , will be the same as the energy required to separate one H-atom leaving gaseous CH_2 , and so on, assuming that these re-

actions could be realized. This case has been discussed by R. Mecke [11, 1930], who thinks it probable that the energy required for the reaction $\text{CH}_4 \rightarrow \text{CH}_3 + \text{H}$ will be greater than the energy required for $\text{CH}_4 \rightarrow \text{CH}_2 + \text{H}$. However, at the present time it is not possible to draw definite conclusions on these points

Generally speaking, it seems probable, according to modern conceptions of valency, that when a bond breaks in a molecule there occurs simultaneous changes in the energies of all other bonds

The dissociation of hexaphenylethane into free triphenylmethyl radicals



which occurs in indifferent solvents is interesting from this point of view. The heat of dissociation has been calculated by K. Ziegler [27, 1929] from equilibrium measurements at different temperatures in different solvents to be about 11 kg-cal. Therefore the energy of the C-C linking between the carbon atoms belonging to the ethane chain in this hydrocarbon, which in this case could be determined separately, is much less than the energy of the C-C linking in paraffins, as computed from heats of combustion. The energy of the ethane C-C linkage is therefore considerably decreased when all the hydrogen atoms of ethane are substituted by phenyl groups, this is in accordance with the chemical instability of hexaphenylethane and related substances. This case has been treated from the standpoint of the modern quantum theory by E. Hückel [6, 1934]. If a molecule of hexaphenylethane dissociates, there occurs a rearrangement of the valencies in each of the two triphenylmethyl groups, by this rearrangement energy of resonance is gained. Therefore the difference between the energy of dissociation (11 kg-cal) and the energy of linkage of the aliphatic C-C bond (73 kg-cal) is, according to Hückel, mainly due to a gain of resonance energy. This would mean that if the 'aliphatic' C-C bond in the molecule of hexaphenylethane breaks, there occur simultaneous changes in the energies of the bonds of the $(C_6H_5)_2C\cdot$ groups which are formed

It seems doubtful if the energies of atomic linkages, as calculated from thermochemical data, can be expected to be equal to activation energies or to the threshold energies of photochemical decomposition

Without regard to these theoretical difficulties several authors have assumed that the energy of activation of a reaction in which a particular atomic linkage breaks is correlated to the energy of this atomic linkage as calculated from thermochemical data

F. O. Rice [14, 1931-4] has attempted to explain the thermal decomposition of paraffin hydrocarbons on the assumption that the primary mechanism is a monomolecular splitting of a linkage by which free radicals are formed. In such calculations the differences in the energies of atomic linkages are important, it is assumed that the energy of activation must be at least equal to the energy of the atomic linkage. If two possible reactions are considered, one of which involves the rupture of a C-C bond and the other that of a C-H bond, the rate of the first reaction at a temperature of 600°C will be already very much greater than the rate of the second reaction, if the difference between a C-H linkage and a C-C linkage is about 20 kg-cal. Rice assumes therefore that the primary formation of free radicals occurs only by the rupture of a C-C bond. It is further assumed that this primary reaction leads to a chain mechanism, and the differences in the binding energies of primary, secondary, and tertiary hydro-

gen atoms, according to Bracket [1, 1928], are taken into account. On the base of these hypotheses an approximate calculation of the proportions of reaction products is given.

However, there are several facts which are not in accordance with the view that a C-C linkage breaks more easily than a C-H linkage. In the thermal decomposition of ethane at 600–700° C. the main reaction is the dehydrogenation to ethylene, which seems to be a homogeneous unimolecular reaction as far as the experimental evidence goes (L. F. Marek and W. B. McCluer [10, 1931]). Here it must be assumed that a C-H linkage splits more easily than a C-C linkage. This conclusion is not in opposition to the statement of F. O. Rice and M. D. Dooley [15, 1933] that CH_3 groups are formed in the thermal decomposition of ethane at higher temperatures (850–950° C.). Two reactions, the splitting of a C-C bond and the splitting of the C-H bonds, may occur simultaneously.

Another interesting reaction from this point of view is the dehydrogenation of hexahydrodrotoluene and of the hexahydroxylenes into hydrogen and the corresponding aromatic hydrocarbons, which reactions occur smoothly at 200–300° C. in the presence of platinum or palladium as catalysts (Zelinsky [26, 1911, 1923]).

Let us consider the heats of reaction of the following reactions



Therefore the decomposition of hexahydrodrotoluene into benzene, methane, and hydrogen will be less endothermic than the decomposition of hexahydrodrotoluene into toluene and hydrogen. The energy value of the $\text{C}_{\text{arom}}-\text{C}_{\text{aliph}}$ linkage in toluene is 83 kg-cal, while the energy of the corresponding C-C linkage in hexahydrodrotoluene is 73 kg-cal. Each of these energy values is smaller than the energy value of the C-H linkage in hexahydrodrotoluene, which is 92 kg-cal. Therefore if the theory of Rice is adopted, one should expect that the C-C bond between the side chain and the ring system in hexahydrodrotoluene should break more easily than the C-H linkage, the reaction should lead then to benzene, methane, and hydrogen. Although in this case a heterogeneous reaction occurs, which cannot yet be treated from the standpoint of chemical kinetics, it is difficult to imagine why the catalytic dehydrogenation of the

hexahydrodrotoluenes and of the hexahydroxylenes should not lead to benzene and methane, besides hydrogen, if the C-C bond breaks more easily than the C-H bond.

According to O. Schmidt [20, 1932–4] the experimental evidence available on the thermal decomposition of paraffins is not in accordance with the view that the breaking of a C-C bond is the primary reaction. He assumes that in many cases the primary reaction is the splitting off of a hydrogen atom, followed by the formation of a double bond. This author deduced from chemical observations an empirical rule for the influence of the double C-C bond on other C-C bonds in the molecule. Schmidt attempts to support this empirical rule by theoretical considerations based upon the conceptions of valence of London-Hatler. In a substance like hexene—1

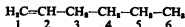

the bond 2–3 next to the double bond will be stronger than the bond 3–4, while the bond 4–5 will again be stronger than the bond 3–4. It is to be noted that in this rule of Schmidt the assumption of the energy equality of the C-C linkages is rejected. As an example of his rule, Schmidt quotes the thermal decomposition of cyclohexene. The main products of this reaction are ethylene and butadiene. Another example is the thermal decomposition of limonene into two molecules of isoprene.

Resuming, it seems doubtful if the energies of atomic linkages as calculated from heats of combustion can be used as a base for the prediction of the course of a thermal decomposition reaction.

When the energy of an atomic linkage is compared with the activation energy of the reaction wherein the rupture of this atomic linkage occurs, the possibility of a difference between the two energy values, which represent an energy of reorganization, must be considered.

Apart from theoretical interpretations, the energies of linkages represent differences of heats of combustion. Therefore the total energy change involved in a given reaction may be computed conveniently from the mean values of the energies of the atomic linkages of the reacting substances, if such substances are considered for which the energy values of the atomic linkages are constant within a sufficient degree of accuracy.

REFERENCES

- BRACKET, *Proc Nat Acad Sci (Washington)*, **14**, 857 (1928)
- FAJAN, *Ker* **53**, 643 (1920), **55**, 2826 (1922)
- *Z Elektrochem* **31**, 63 (1925)
- *Z physik Chem* **99**, 393 (1921)
- GRUBB, H. GILCHRIST-STEWART, *Handbuch der Physik*, **24**, 536 (1926)
- HÜCKEL, E. *Trans Faraday Soc*, **30**, 40 (1934)
- KHARASCH, quoted from Landolt-Börnstein, *Tabellen*, 5e Auflage, 2er Ergänzungsband
- KORN and GUCKEL, *Z physik*, **3**, 143 (1920)
- LANDOLT-BÖRNSTEIN, *Physik Chem Tabellen*, 5e Auflage, 2er Ergänzungsband
- MAREK, L. F., and McCLUER, W. B. *Ind Eng Chem* **23**, 1878 (1931)
- MECKE, R. *Z physik Chem* **7**, 108 (1930)
- NORRISH, R. G. W. *Trans Faraday Soc*, **30**, 102 (1934)
- PAULING, L. *JACS* **54**, 3570 (1932)
- RICE, F. O. *JACS* **53**, 1959 (1931), **54**, 3529 (1932), **55**, 3035, 4245 (1933), *Trans Faraday Soc*, **30**, 152 (1934)
- RICE, F. O., and DOOLEY, M. D. *JACS* **55**, 4245 (1933)
- RICHARDS and JESS, quoted from Landolt-Börnstein, *Tabellen*, 5e Auflage
- ROBBIN, F. D. *J of Research Nat Bur of Standards (Washington)*, **13**, 21 (1934), *Proc Nat Acad Sci (Washington)*, **20**, 323 (1934)
- ROTT, W. A., and AUWERA, K. v. *Ann* **407**, 170 (1915)
- RUZICKA and SCHLÄPFER, *Helv* **16**, 162 (1933)
- SCHMIDT, O. *Z physik Chem*, **A**, **159**, 337 (1932), *Z Elektrochem* **39**, 969 (1934), *Ber* **67**, 1870 (1934)
- SIDOWICK and BOWEN, *Annual Reports of Chemistry*, **1931**, 317
- SWIENTOWILAWSKI, *JACS*, **42**, 1092 (1920)
- THOMSEN, *J Thermochemische Untersuchungen*, **4**, (1886)
- WIBAUT, J. P. *Rec trav chim* **41**, 441 (1922)
- *Rec trav chim* **41**, 96 (1922)
- ZELINSKY, *Ber* **44**, 3121 (1911), **56**, 787 (1923)
- ZHIGLER, *K Ann* **473**, 179 (1929)

THE DIELECTRIC CONSTANT OF PETROLEUM AND PETROLEUM PRODUCTS

By G. M. L. SOMMERMAN

American Steel and Wire Company, Worcester, Mass

The dielectric constant of petroleum and petroleum products is an important property for two reasons. The first is that accurate dielectric constant data, when correctly analysed, may be used to indicate the presence of various constituents such as asphalts, resins, and oxidized compounds. The second reason is that the dielectric constant of petroleum products used in equipment such as impregnated paper condensers and high-voltage cables affects the electrical properties of the equipment.

The dielectric constant ϵ of a material may be defined as the ratio of the capacity of a condenser with the material between the condenser plates C to that with the condenser empty and under vacuum C_0 , i.e. $\epsilon = C/C_0$. Inasmuch as the dielectric constants of the various petroleum products are in the neighbourhood of 2, and the dielectric constant of air is only 0.0006 greater than the value, unity, for vacuum, no serious error arises from using for C_0 the capacity value obtained with the condenser filled with air.

From the foregoing it is obvious that to measure dielectric constant it is only necessary to compare the capacity of a suitable condenser or measuring cell, both filled and empty, with that of a standard condenser by means of an appropriate measuring circuit. The usual measuring circuits are various forms of alternating-current bridges for frequencies up to 50,000 cycles, and resonance circuits or heterodyne beat methods for the higher radio frequencies. For measurements on liquids, the measuring cells usually consist of one cup-shaped electrode surrounding another, concentric cylinders, or parallel plates, often with a third or guard electrode to eliminate edge effects and stray capacities. Since it is desirable to make dielectric constant measurements at a number of temperatures, some form of temperature control should be provided.

Solids such as waxes may be measured by filling a cell with the melted substance, but the dielectric constants so obtained are almost invariably low because of the contraction occurring with solidification, and consequent formation of voids, or air spaces, which decrease the capacity. A better way is to mould a disk of the wax under vacuum and then apply mercury or foil electrodes, using for the corresponding air capacity, $C_0 = 0.0885S/h$ micromicrofarads. Here S is the surface area of the electrode in sq cm, and h is the thickness of the disk in cm.

Dielectric constant testing, in common with other electrical testing, may be adopted to record and control processes automatically.

For more detailed descriptions of dielectric constant measuring apparatus and technique the reader is referred to references [1, 1933, 4, 1930, 8, 1934, 12, 1931, 15, 1934] given at the end of the article.

The dielectric constants of petroleum products vary from 1.8 to 2.6 in the manner shown in Table I.

The dielectric constant of petroleum and its products is equal to or is somewhat larger than the square of the refractive index. Refining usually reduces the dielectric constant. The dielectric constant increases with the density of the product. The dielectric constant of highly refined petro-

TABLE I
Dielectric Constant of Petroleum Products

Material	Dielectric constant
Gasoline	1.85-2.0
Kerosene	2.0-2.2
Transformer oil	2.1-2.3
Lubricating oil	2.1-2.6
Vaseline	2.05-2.3*
Paraffin, liquid	2.05-2.1
" solid	2.05-2.4*

* Wide variation caused by gas pockets

leum products is essentially constant over the frequency range 25 to 10^6 cycles. For less pure products the dielectric constant may decrease but never increase with increase in frequency. The dielectric constant of oils almost always decreases with temperature increase.

In order to understand the reasons for these characteristics of dielectric constant, and to be able profitably to apply actual data, it is necessary to look into some of the underlying theory of dielectric constant and the experimental verification.

Following the promulgation of the theory of polar molecules by Debye in 1912, the subject of dielectric constant of gases and organic compounds was put on a very sound basis. Hundreds of papers have been published containing data which have served to corroborate the theory. Most of the experimental verification has been obtained on pure chemical compounds or binary mixtures thereof. Some of this data on compounds of interest to the petroleum technologist will be presented here. Also, sufficient data obtained on commercial petroleum products will be presented to show the conformity with the more fundamental work. Readers interested in a more complete description of the fundamentals of dielectric constant than that given here are referred to the works of Debye [3, 1931] and of Smyth [12, 1931].

It is the premise of the Debye theory that there are two basic types of molecules (1) non-polar molecules, which have symmetrical structures of atoms, (2) polar molecules, which have unsymmetrical structures of atoms. Non-polar molecules have no permanent electric moment, and materials composed exclusively of such molecules have dielectric constants which are essentially equal to the squares of the refractive indices (the optical dielectric constants), and which are affected by temperature only through the change in density. Polar molecules have a permanent electric moment and are in effect little electric doublets. These doublets rotate back and forth in an alternating electric field (provided the frequency is not too high), and so give an additional contribution to the dielectric constant. Consequently, materials containing polar molecules have dielectric constants which are greater than the squares of the refractive indices.

With sufficiently high frequencies, usually at high radio frequencies, the polar molecules can no longer follow the field, and so the dielectric constant decreases to its optical

value. It is also a property of materials containing polar substances that the dielectric constant decreases with temperature more rapidly than can be accounted for by the decrease in density. This is due to increased restriction of polar molecular orientation with the increased heat motions of the molecules at higher temperatures.

It has been shown that saturated hydrocarbons are non-polar materials. Since highly refined petroleum products are made up almost entirely of saturated hydrocarbons, their dielectric constants have the characteristics listed above for non-polar materials. It has also been shown that unsaturated hydrocarbons are usually very weakly polar, and resins, asphalts, and all oxidized hydrocarbons are somewhat polar. Therefore, crude oils, semi-refined, and deteriorated petroleum products are mixtures of rather weakly polar substances and non-polar substances. Consequently, the dielectric constants of such products partake somewhat of the characteristics listed above for polar materials. As petroleum is refined, the characteristics of the dielectric constant become more and more like those of non-polar materials.

A comparison of the dielectric constant and the square of the refractive index for various substances is given in Table II. The first part of the table gives data for non-polar compounds—saturated hydrocarbons and refined petroleum products. The second part of the table gives data for polar compounds.

TABLE II

Dielectric Constant and Square of Refractive Index for Non-polar and Polar Materials

Material (observer)	Formula	Refractive index		Dielectric constant	
		n^2	n^4	ϵ	$\epsilon - n^4$
Non-polar materials					
Benzene [12]	C_6H_6	1.501	2.253	2.283	0.030
Cyclohexane [10]	(C_6H_{12})	1.427	2.036	2.055	0.019
n-Hexane [13]	$CH_3(CH_2)_4CH_3$	1.375	1.890	1.890	0.000
n-Heptane [14]	$CH_3(CH_2)_5CH_3$	1.388	1.926	1.930	0.004
3 Et. pentane [14]	$(C_8H_{18})C_2H_5$	1.394	1.943	1.942	-0.001
Kerosene [9]	Hydrocarbon	1.469	2.100	2.125	0.025
Paraffin oil [9]	Hydrocarbon	1.481	2.193	2.195	-0.002
Vaniline [9]	Hydrocarbon	1.480	2.190	2.078*	-0.112*
Heavy petroleum base compound [7]	Hydrocarbon	1.483	2.199	2.15*	-0.05*
Polar materials					
n-Octylene [5]	$CH_3(CH_2)_6CH_3$	1.41	1.985	2.195	0.21
n-Butyric acid [5]	$CH_3(CH_2)_3COOH$	1.40	1.96	2.32	0.36
Chlorobenzene [5]	C_6H_5Cl	1.525	2.325	2.94	3.61
n-Butyl chloride [5]	$CH_3(CH_2)_3CH_2Cl$	1.40	1.96	2.65	0.69
Cresol [5]	$CH_3O(CH_2)_2CH_3$	1.47	2.16	3.06	0.90
Cyclohexanol [10]	$(C_6H_{11})_2O$	1.54	2.37	3.09	0.72
Heavy petroleum base compound + 3% nitrobenzene [7]	Hydrocarbon $+ C_6H_5NO_2$	1.483	2.20	2.68	0.48

* Dielectric constant is low because of air pockets

The small differences between the dielectric constant and the square of the refractive index for the non-polar materials (0.04 or less) are due to causes other than polar molecular orientation [12, 1931]. It is apparent that the saturated hydrocarbons of all series—paraffin, naphthene, and aromatic—are non-polar. Even the iso-compounds of these series, although possessing dissymmetry in the hydrocarbon groups, are non-polar, as shown by the results for 3-ethyl pentane and the other isomers of heptane obtained by Smyth and Stoops [14, 1928]. The data for the refined petroleum products

show that these products contain practically no polar compounds.

The much larger values for dielectric constant minus square of refractive index given for the polar materials are almost entirely caused by the orientation of polar molecules. These differences are a rough measure of the number of polar molecules present and the degree of their polarity. Unsaturated hydrocarbons with the double bond unsymmetrically located are weakly polar, organic acids are somewhat more strongly polar, while halogenated hydrocarbons and hydrocarbons containing hydroxyl groups, if unsymmetrical, are quite strongly polar.

The decrease in dielectric constant with frequency which occurs with polar materials does not take place until frequencies higher than 3×10^7 cycles are reached, if the substance measured is in the form of a thin liquid, as it usually is in the case of pure compounds. However, for petroleum compounds, where much higher viscosities are attained, the effect takes place at lower frequencies. Thus for mixtures of simple polar materials in the very viscous petroleum compound reported in Table II, Johnstone and Williams [7, 1929] found the dielectric constant to be constant up to about 3×10^6 cycles, after which it gradually decreased to its optical value at about 10^8 cycles. The viscosities were of the order of 10 to 20 poises in these cases. The dielectric constant of the petroleum compound alone was found to be independent of frequency throughout this range, which is an additional indication of its non-polar character.

The frequency region in which the dielectric constant decreases may be still lower in the case of solid compounds. Jackson [6, 1935] has recently shown that the decrease occurs at frequencies less than 10^8 cycles for 4.8% cetyl palmitate (polar) in paraffin.

Also, if solid compounds contain a relatively large number of free ions caused by the partial dissociation of organic acids and similar materials which may be present, an additional contribution to the dielectric constant, due to the restricted oscillatory motion of the ions, comes into play as the frequency decreases below 1,000 cycles. Thus Sommerman [16, 1935] found that on adding 10% stearic acid to paraffin, a sufficient number of ions was formed through dissociation to increase the dielectric constant by an amount 0.012 when the frequency was decreased from 1,200 to 65 cycles. This effect was in addition to that caused by the orientation of the weakly polar stearic acid molecules which gave a constant contribution to the dielectric constant over the frequency range 65 to 7×10^6 cycles. The paraffin alone was of such purity that the dielectric constant was independent of frequency to within 0.002.

Just as the specific refraction such as that of Lorentz and Lorenz,

$$R = \frac{n^2 - 1}{n^2 + 2} \frac{1}{d^3} \quad (1)$$

is found to be independent of temperature, so also the corresponding expression for dielectric constant, which may be called the specific polarization,

$$P = \frac{\epsilon - 1}{\epsilon + 2} \frac{1}{d^3} \quad (2)$$

is essentially independent of temperature for non-polar compounds, including refined petroleum products. Examples are given in Table III.

The data show that the variations in dielectric constant with temperature are essentially accounted for by the variations in density. It is also indicated that the variation in dielectric constant with series (paraffin, naphthene, aromatic)

TABLE III

Dielectric Constant and Specific Polarization of Non-polar Materials

Material	Temperature °C	Dielectric constant ϵ	Density d	Specific polarization $P = \frac{(\epsilon-1)}{(\epsilon+2)d}$
Benzene [5]	10	2.296	0.8895	0.3392
	20	2.283	0.876	0.3419
	60	2.204	0.8365	0.3422
n-Hexane [13]	0	1.918	0.678	0.3456
	20	1.890	0.662	0.3456
	60	1.817	0.623	0.3435
n-Heptane [14]	0	1.958	0.700	0.3457
	20	1.930	0.684	0.3459
	60	1.873	0.648	0.3478
Heavy cylinder oil	30	2.263	0.890	0.3329
	45	2.226	0.880	0.3316
Mid-Cont crude [18]	60	2.216	0.870	0.3316
	70	2.070	0.770	0.3415
Paraffin (liquid) [16]	90	2.051	0.759	0.3418
	20	2.055	0.779	0.3340

and with molecular weight are also essentially accounted for by the corresponding variations in density. There does appear to be a small reduction in the specific polarization with increase in molecular size, the values for some oils running as low as 0.327. However, the extreme limits of the polarizations, 0.327 and 0.345, are very close in view of the wide ranges of molecular weight and types of molecular structure included.

From the fact that the expression (2) for the specific polarization is so nearly unaffected by temperature change for saturated hydrocarbons, an expression may be derived for the change in dielectric constant with temperature, $\partial\epsilon/\partial T$, in terms of the coefficient of thermal expansion. This takes the form

$$\frac{3}{(\epsilon+2)(\epsilon-1)} \frac{\partial\epsilon}{\partial T} = \frac{1}{d} \frac{\partial d}{\partial T} \quad (3)$$

the right-hand side of the equation being the negative of the expansion coefficient. For refined oils the expansion coefficient is about 0.0007 per °C, and $\epsilon = 2.2$, so that the change in dielectric constant with temperature for such oils is about -0.0012 per °C, or about -0.055% per °C.

For materials containing polar molecules in not too large concentrations the decrease in dielectric constant with temperature is greater than that for non-polar materials. Also, the specific polarization decreases with temperature. This is shown in Table IV.

It follows that the dielectric constants of crude oils, semi-refined oils, and deteriorated oils have larger temperature coefficients than the value given above for refined oils. The data for the semi-refined naphthene oil given in Table IV are illustrative of this.

The dielectric constant of materials containing polar substances also decreases with decreasing temperature if the viscosity and frequency are high enough. This is analogous to the decrease in dielectric constant with frequency for such materials.

The point has now been reached where it is possible to outline ways in which dielectric constant measurements on petroleum products may be utilized.

It is evident from Table III that the dielectric constant is lowest for paraffinic compounds, highest for aromatic

TABLE IV

Change in Dielectric Constant and Specific Polarization with Temperature for Materials containing Polar Compounds

Temperature °C	Dielectric constant ϵ	Density d	Specific polarization $P = \frac{(\epsilon-1)}{(\epsilon+2)d}$
21% chlorobenzene in hexane [13]			
0	2.584	0.7815	0.442
30	2.456	0.753	0.434
60	2.347	0.723	0.428
17% ethyl bromide in hexane [13]			
-20	2.752	0.8105	0.455
20	2.552	0.769	0.443
40	2.444	0.748	0.435
Semi-refined naphthene base oil, $\eta_{sp} = 17$ poises [18]			
30	2.530	0.932	0.3623
45	2.501	0.924	0.3610
60	2.470	0.915	0.3595

compounds, and in between for naphthenic compounds. However, it is equally evident that but little additional information concerning the nature of basic series of hydrocarbons present in an oil can be obtained from the dielectric constants over that obtainable from density measurements. Therefore, for determinations of the base of oils, analysis of dielectric constant data is far less effective than the method of viscosity-gravity constants or of viscosity-temperature characteristics.

The principal value of dielectric constant measurements as an analytical tool is that they can be used to give a measure of the amounts of polar compounds, such as unsaturated, resinous, and oxidized compounds, present in oils. If these compounds are present in fairly large quantities, it is sufficient to use the difference between the dielectric constant and the square of the refractive index (obtained at a standard temperature) as a measure of the amount of polar compounds present. Where materials of wide ranges in density are being compared, it is better to compare the differences between the specific polarizations and the specific refractions,

$$P_M = \frac{\epsilon-1}{\epsilon+2} \frac{1}{d} - n^2 - 2 \frac{1}{d} \quad (4)$$

Another way of obtaining a measure of the amount of polar substances present in an oil depends on the fact that the specific polarization as a function of temperature is of the form $P = a + b/T$, where a and b are constants and T is the absolute temperature. This is true for dilute solutions of polar materials in non-polar materials only, but this condition is approximated closely by oils. It is thus only necessary to measure the dielectric constant and density over a fairly wide range of temperatures, say, from 20 to 100°C. The specific polarizations P are then calculated for various temperatures. If these values are multiplied by the corresponding absolute temperatures, and the products PT plotted against T , straight lines of positive slope are obtained, which, if extrapolated to zero absolute temperature, give a positive intercept on the PT axis. This quantity (b) divided by a standard absolute temperature, say, 293° Abs, gives a measure of the polar material present, which should be about the same as obtained from (4).

As an example, consider the data for the semi-refined oil given in Table IV. The products PT are 109.8, 114.8, 119.6

for 303, 318, 333° Abs., respectively. The intercept at $T = 0$ is 10.8, and this divided by 293 gives $P_{at 0} = 0.0369$ as a measure of the polar material present. Also, $P - P_{at 0}$ is 0.3268, which is about what is usually obtained for highly refined oils of high boiling-point.

In taking dielectric constant-temperature data for such purposes it is well to have an accuracy of 0.2%. It is necessary to measure the capacity of the empty cell C_0 over the whole temperature range studied, because the changes in this capacity with temperature are often comparable with the changes which occur in the specific polarization.

When mineral oils are heated while exposed to the air, the oxidized compounds which are formed include peroxides, alcohols, acids, and esters, all of which are polar. The formation of these polar molecules results in an increase in the dielectric constant of the oils which progresses with the time of ageing. Thus Whitehead [18, 1933] observed that for an oil originally having a dielectric constant of 2.265 and a density of 0.898 the dielectric constant increased to 2.34, with no corresponding change in the density, after air had been bubbled through the heated oil.

A more extended study in which the increase in the dielectric constant was used as a measure of oxidation of oils is that of Stoops [17, 1932]. Three types of transformer oils were heated in air at 120° C. Periodic measurements of dielectric constant were made, which allowed curves for increase in dielectric constant versus time to be plotted. From these it was shown that the dielectric constant increased in amounts of from 0.01 to 0.02 per day, and it was possible by this method to rate the oils as to their resistance to oxidation. It was also shown that heating the oils under nitrogen caused only very small increases in the dielectric constants. The increases in the dielectric constants of the oils were correlated with the increases in saponification numbers, and it was also shown that the dielectric constant increases produced by ageing could be made to disappear at very high frequencies.

The formation of polar compounds resulting from the oxidation of oils, in addition to increasing the dielectric constant, also increases the spreading of oil films on water. Because of partial ionic dissociation of the polar compounds the electrical conductivity and power factor of the oils are also greatly increased as a result of oxidation. Measurements of the changes in the electrical properties of oils with artificial ageing are widely used in the study of the stability of transformer oils and oils for use in high-voltage cables.

The principal types of electrical equipment in which the dielectric constant of the petroleum products used in the equipment is of direct importance are paraffined paper and oil-impregnated paper condensers and oil-impregnated paper insulated cables. The dielectric constant of the resultant hydrocarbon-cellulose combinations is about 4.

The changes in the dielectric constant of impregnated paper with temperature are small enough, so that the constancy of the capacity of impregnated paper condensers is sufficiently good for a wide variety of commercial applications. Much work has been done recently on the development of halogenated hydrocarbons which, because of their

polar properties, have much higher dielectric constants than those of the normal hydrocarbons, and so lead to much smaller dimensions for the resulting condensers (see Clark [2, 1934]).

In oil-impregnated paper cables it is desirable that the dielectric constant of the impregnating oil be low from one standpoint and high from another standpoint. From a power-consumption standpoint it is usually desirable that the charging current of the cables be as low as possible. To realize this the dielectric constant of the impregnated paper, and, therefore, of the impregnating compound, must be as low as possible. However, as far as the stability of the insulation under continued high voltage is concerned, it would be desirable to have a higher dielectric constant for the impregnating compound. This is so because in an insulation wall made up of two dielectrics in series (in the present case, oil and cellulose) alternating electrical stress divides in inverse proportion to the dielectric constants of the two materials. Since the dielectric constant of the impregnating oil is only 2.2 as against a value of about 4 for impregnated paper, the stress on the oil is nearly twice the average stress in the insulation. Thus, together with the fact that the dielectric strength of oil is much less than that of cellulose, causes the oil spaces in the cable to fail first. The stress on the impregnating compound would be lowered and the break-down strength of the insulation raised if the dielectric constant of the impregnating compound were raised to higher values. This has been realized in the case of impregnated paper, high-voltage condensers (see Clark [2, 1934]) where the higher charging current is actually an advantage as stated above. Despite the conflicting effects in the case of cables, the possibility of using cable-impregnating compounds of higher dielectric constant is receiving increasing attention (see Roper [11, 1935]).

Summary

The dielectric constants of petroleum and petroleum products are in the neighbourhood of 2. For highly refined petroleum products the dielectric constants are approximately equal to the squares of the refractive indices, are independent of frequency up to 10^8 cycles, and vary with temperature, base, and boiling-point essentially in accordance with the corresponding density variations. In crude petroleum, semi-refined petroleum products, and denatured petroleum products the presence of unsaturated compounds, asphaltic and resinous material, and oxidized compounds causes the dielectric constants to be greater than the squares of the refractive indices, and to decrease more rapidly with increase in temperature than accounted for by the density variations. The dielectric constants of these impure products also decrease with frequency in the upper radio-frequency range. Dielectric constant data thus give a measure of the amount of materials usually considered undesirable in petroleum products, and may also be used to follow the oxidation of petroleum products. The dielectric constants of the petroleum products used in impregnated paper-insulated condensers and cables directly affect the properties of these articles.

REFERENCES

1. A. S. T. M. Standards on Electrical Insulating Materials, pp. 54-7, 94-110 (1933).
2. CLARE, F. M. *Trans Amer Electrochem Soc* 65, 39 (1934).
3. DAVIS, P. *Polar Molecules* (Chem. Cat. Co., 1931).
4. HAOUS, B. *Alternating Current Bridge Methods* (Pitman and Sons, 1930).
5. *International Critical Tables*.
6. JACKSON, W. *Proc Royal Soc.* 186, 197 (1935).

- 7 JOHNSTONE, J H L, and WILLIAMS, J W *Phys Rev* 34, 1483 (1929)
- 8 KOUWENHOVEN, W B, and MARKS, L W *Proc A S T A* 34, 11, 821 (1934).
- 9 ONCLEY, J L, and WILLIAMS, J W *Phys Rev* 41, 340 (1933)
- 10 RICHARDS, T W, and SHEPLEY, J W *J A C S* 41, 2002 (1919)
- 11 ROPER, D W *J Amer Inst Elec Eng* 54, 323 (1935)
- 12 SMYTH, C P *Dielectric Constant and Molecular Structure* (Chem Cal Co, 1931)
- 13 SMYTH, C P, and MORGAN, S O *J A C S* 50, 1547 (1928)
- 14 SMYTH, C P, and STOOPE, W N *J A C S* 50, 1883 (1928)
- 15 SOMMERMAN, G M L *Rev Sci Instruments*, 5, 341 (1934)
- 16 ——— *J Franklin Inst* 219, 433 (1935)
- 17 STOOPE, W N *Physica*, 2, 322 (1932)
- 18 WHITEHEAD, J B *Trans Amer Inst Elec Eng* 52, 667 (1933)

INTERFACIAL TENSION

By Professors H. WEISS and E. VELLINGER

University of Strasbourg

PETROLEUM products show little variation among themselves of surface tension against air, but the interfacial tension against aqueous solutions provides information of value. Previous workers have observed the fall of interfacial tension of oils against water when alkali is added. The drop-weight method has been used, but this is not suitable for measurements of its variation with time. For this, the ring method is best and the authors have used the apparatus of de Noüy. This consists of a torsion balance to measure the force required to draw a small platinum ring normally from the interface. The diameter of the ring and the mechanical constants of the apparatus are so chosen that the drum, which is rotated to draw out the ring, is calibrated directly in cgs units. The writers found it best to draw the ring from the aqueous layer to the oil. If done in the opposite direction, errors difficult to eliminate may be incurred. To make a run, about 20 c.c. of the aqueous solution are poured into a 50 c.c. beaker, the ring is immersed and then a layer of oil at least 1 cm thick is added. At this moment a chronometer is started and the operator begins to turn the drum of the Tensiometer. The time between contact of the two liquids and withdrawal of the ring is noted.

Variation of Interfacial Tension with Time.

The interfacial tension of all oils varies with time. Unless the oil has undergone considerable decomposition or is badly refined a series of measurements may be made on one specimen by replacing the ring and withdrawing it from the interface at known time intervals. The rate of change varies with the nature of the oil and the pH of the aqueous solution. It increases with pH and with the amount of impurity present in the oil. For comparison of different products the authors find 30 sec a convenient time interval, after which measurements may be made.

Influence of pH of Aqueous Solution.

Plotting the interfacial tension against pH gives one of three types of curve: (Fig. 1)

1. fairly parallel to the pH axis save for small variations
2. curves falling rapidly towards the pH axis with alkaline solutions
3. bell-shaped curves with a marked maximum in the neighbourhood of neutrality

Highly refined oils containing substances not dissociated by water, such as alcohols, ketones, &c., and having but slight surface activity form class 1. The value of the interfacial tension then depends upon the concentration of these substances. Oils giving the second type of curve are those containing active acids. These are oils which have been refined badly or which have undergone decomposition. The third type is given especially by crude distillates, these contain active acids and bases. Measurements made against standard buffer solutions therefore give valuable information of the nature of the impurities present.

Influence of Change of Composition of the Oil.

Mineral oils, subject in use to chemical agents or physical conditions, undergo fairly rapid and considerable change,

the extent of which depends upon the physical-chemical properties of the oil. The interfacial tension/ pH curves show this alteration. For example, marine turbine oils vary with length of service. First, the curve is translated in the direction of smaller interfacial tension. Then the top of the curve for large pH values falls more and more rapidly as decomposition proceeds. The rate of fall de-

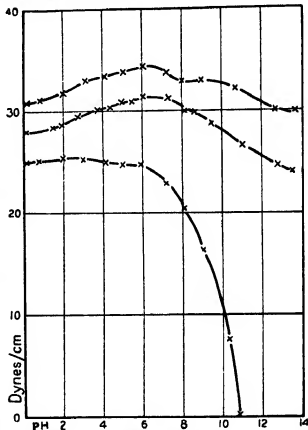

Fig. 1 Relationship between interfacial tension and pH value for typical mineral oils

pends upon the oil and the agents responsible for the decomposition (Fig. 2)

The same phenomenon is produced artificially by heating the oil in air to quite moderate temperatures, $c. 100^{\circ}$ - 120° . For a given pH the change of interfacial tension with time consists, first, of a rapid fall which then slows up and in certain cases tends to become asymptotic (Fig. 3). This behaviour is due to two causes. First, as active substances are formed in the oil, their concentration is much greater at the surface by adsorption. A further equal amount of active substance formed in the oil will then have a much smaller effect on the interfacial tension in proportion to the extent to which the adsorbed surface layer has approached saturation. Also, the active substances themselves change and form insoluble precipitates which have no effect upon the surface tension. Sometimes the flattening of the curve coincides with the appearance of this deposit sometimes the

fall continues after its appearance, which shows that the rate of formation of active substances is greater than that of their elimination as insoluble deposit

The service of a turbine oil is usually ended by tendency

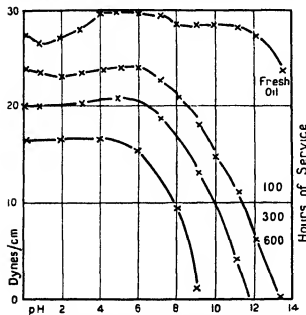

FIG 2 Effect of ageing on interfacial tension of a turbine oil

to formation of emulsions of excessive stability. This may be due to the presence of considerable amounts of the deposit mentioned above or to great lowering of the interfacial tension between oil and condensed water. The pH of this water depends on the amount of boiler water carried

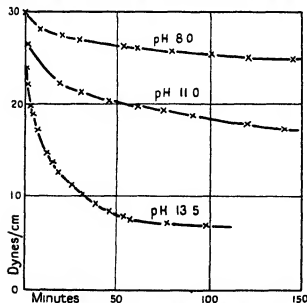

FIG 3 Change of interfacial tension with time

over by priming and upon the amount of water-soluble organic acids formed in the oil by chemical change. In most cases this pH is between 5 and 7, so that the water is slightly acid or neutral. Other conditions being the same, the speed of de-emulsification depends upon the interfacial

tension, so that the tendency of an oil to form stable emulsions may be estimated in this way. The method is more reliable than that of laboratory preparation of emulsions and examination of their stability, since the working conditions under which emulsification occurs are quite different from laboratory methods of preparation.

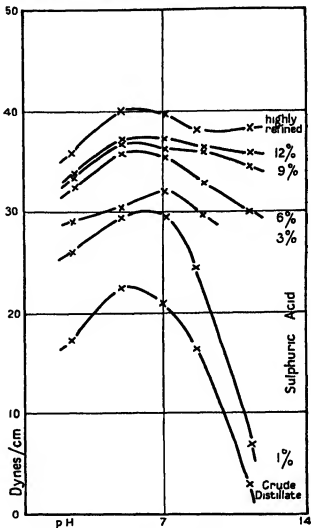

FIG 4 Effect of sulphuric acid refining on the interfacial tension of a crude distillate oil

Interfacial Tension and Chemical Refining.

Measurements of interfacial tension enable us to follow the course of chemical refining of oils, since each of these methods depends upon the introduction and subsequent elimination of surface active molecules.

Action of Sulphuric Acid.

Interfacial tension does not allow us to study the action of sulphuric acid alone, since this treatment leaves a considerable amount of surface active substances in the oil. The interfacial tension of oil after acid treatment, decantation of sludges, and filtration is extremely low, approaching zero. The method gives a result only after a supplementary treatment, which always has the same object—elimination of active substances. The treatment is washing, neutralization, and filtration through absorbent earths. In practice the

problem is to know the extent of refining achieved by the secondary operations after a treatment of the intensity of that of sulphuric acid. It is only necessary that these secondary operations should be carried out in a manner sufficiently regular to reproduce the same degree of washing as near to complete as possible. Results obtained from the action of increasing amounts of sulphuric acid on a crude distillate illustrate the method (Fig 4). The curve is at first of the bell-shaped type, then passes to the second type and then to the first, starting from 3% of acid.

If the washing is carried out before the sulphuric acid sludges have been eliminated, these are hydrolysed and liberate active substances which dissolve in the oil. But if the washing is done after complete elimination, it has a favourable action. These changes are easily followed by interfacial tension measurements.

Even after washing with water, the oil is acid. Neutralization and elimination of these acid products is necessary. If neutralization is carried out by a wet way with a solution of soda, there are formed thick acid-salt solutions of great surface activity which form very stable emulsions. It is, therefore, preferable to work by a dry method using Na_2CO_3 . Each method has its advantages and disadvantages. In the wet method, the soaps formed are more soluble in water than in oil and so are almost completely eliminated, only a small quantity of absorbent earth being required to complete the operation. In the dry method, the soaps remain dissolved in the oil and a much greater quantity of absorbent earth is needed to remove them less perfectly. All these processes are followed by the interfacial tensions which are very sensitive to small quantities of soaps in the oils.

Treatment by absorbent earths is intended to eliminate

from the oil active reaction products which have escaped previous stages or which result from them. Their action is faithfully followed by interfacial tension results which show that a given amount of earth improves the oil towards a limit which depends upon their activity and upon the previous treatment of the oil. The optimum amount can then be chosen to avoid needless loss.

Treatment by Solvents.

This method is a substitute for the sulphuric acid treatment. When active solvents, such as phenol, are used the problem of complete elimination of solvent arises before the method can be used for judging the efficiency of treatment.

Conclusion.

The study of the interfacial tensions of mineral oils against aqueous solutions of various pH is a rapid and convenient method for measuring the number of active molecules in the oil and is of special value for substances of small activity and in small concentrations. Other cases can be examined by chemical methods. In general, it enables us to classify these active molecules according to the interfacial tension/ pH curve. The principal applications are control of changes in the oil which give rise to soluble products and of chemical refining. It enables us to follow the various operations of the latter and to correct them immediately in case of need with an accuracy which exceeds other methods of control. It is a simple method for determination of optimum quantities of certain reagents required.

SELECTED BIBLIOGRAPHY

- WEISS, H., and VELLINGER, E. *Ann off nat comb liq* 1929, no 4, p 649, *Comptes rendus du Congrès du Graissage*, 334 (Strasbourg, 1931).
 ———. *World Petr Congress*, 423 (London, 1933).
 VELLINGER, E. *Comptes rendus du Congrès du Graissage*, 354 (Strasbourg, 1931), *Ann off nat comb liq* 1931, no 2, 225.

- VELLINGER, E. and DELION, R. *Comptes rendus Acad des Sciences*, 198, 2084 (1934).
 VELLINGER, E. and RADULESCO, G. *Comptes rendus du Congrès du Graissage*, 360 (Strasbourg, 1931), *Ann off nat comb liq* 1934, no 2, 279, *World Petr Congress*, 407 (London, 1933).

INTERFACIAL TENSION

By A. S. C. LAWRENCE, Ph.D.

Laboratory of Colloid Science, Cambridge, England

BETWEEN liquids not completely miscible there is a residual interfacial tension. This is analogous to ordinary surface tension with the essential difference that the two phases play a more nearly equal part. In ordinary surface tension the measurement is usually made against air, which has practically no effect. In the case of mercury the difference between the surface tension *in vacuo* and in hydrogen is 20 dynes per cm lowering by the latter gas. This, however, is only about 5% of the surface tension.

Thomas Young's simple picture of the origin of surface tension may be applied equally well to interfacial tension. Ordinary surface tension is the uncompensated inward pull on the surface due to molecular attraction (Fig. 1). As he

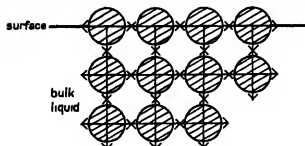

FIG. 1. Young's picture of the origin of surface tension.

pointed out, the most obvious proof of the existence of this force is the fact that the substance is in the liquid state and that its molecules do not fly apart to the gaseous state. It should be noted that surface tension tends to reduce the total surface area, so that the surface behaves as if in a state of tension—hence the name. But the origin of surface tension is a force normal to the surface, and surface area is reduced by movement of molecules from it normally to it.

The exact treatment of this common-sense view has been provided by the work of Eotvos, Ramsay, and Shields, who found that the value of the surface tension of a liquid depends upon its distance from its critical point, at which, of course, σ becomes zero.

Interfacial tension is the differential resultant pull (Fig. 2). Its numerical value will depart from the simple

to its own species

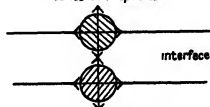

FIG. 2. Interfacial tension.

arithmetical difference by a factor depending upon the amount of interaction between the two surfaces. This is expressed by Dupré's equation for the work of adhesion of two liquids in contact.

$$W_{ad} = \gamma_a + \gamma_b - \gamma_{ab}$$

Where there is sufficient affinity between the two liquids, they will be miscible in all proportions and the interfacial tension zero. The problem of interfaces resolves itself into two cases:

- partially miscible liquids,
- immiscible liquids.

How small the mutual solubility must be for class (a) to pass to class (b) cannot be defined, but a criterion upon which a separation can be made will appear in the section on emulsions. It is certain that intermediate systems can exist, but to understand the nature of the processes involved it is better to consider the definitely separated cases.

Interfacial Tension of Partially Miscible Liquids.

With interfacial tension, as with surface tension, the most interesting cases are solutions rather than pure liquids. With partially miscible liquids we are dealing with a solution, of *B* in *A* against a solution of *A* in *B*, even before any other substance is added. Antonow has pointed out that the interfacial tension between two liquids is equal to the difference between their surface tensions against air. This relation obviously requires that, for mutually soluble substances, the surface tensions against air should be those of *B* in *A* and *A* in *B*. Table I shows results for some organic liquids against water. The surface tensions of water in the organic liquids do not depart far from the values for the pure liquids, but there are large differences in the aqueous solutions. The value for pure water is 73 dynes per cm at 15° C.

TABLE I

Liquid	Surface tension		Interfacial tension	
	Aqueous solution of liquid	Liquid solution of water	Calculated	Observed
Benzene	63.2	28.8	34.4	34.4
Ether	28.1	17.5	10.6	10.6
Aniline	46.4	42.2	4.2	4.8
Chloroform	59.8	26.4	33.4	33.3
Carbon tetrachloride	70.2	26.7	43.5	43.8
Nitrobenzene	67.9	43.2	24.7	24.7
Amyl alcohol	26.3	21.5	4.8	4.8
Cresol	37.8	34.3	3.5	3.9

As temperature rises, the mutual solubilities increase until the liquids become miscible at the 'critical solution temperature', better and more tersely named in America, 'consolute temperature' (Fig. 3). Table II gives some values of solubilities of organic liquids in water and their consolute temperatures. Table III shows some effects of molecular constitution on this property.

It will be seen that, in the substituted phenols, the presence of the non-polar groups has the greatest reducing effect on the hydrophilic of —OH group when next to it in the *ortho* position.

It is also seen that the NO₂ group has greatest effect on the —OH, when in the *ortho*, and least in *meta* and *para* positions.

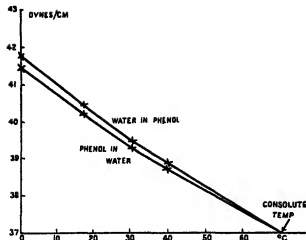

Fig 3 Surface tensions (against air) of saturated solutions of water in phenol and phenol in water (Goard and Rideal) *J C S* 1925, 510

TABLE II
Consolute Temperatures and Compositions Organic Liquids with Water

Substance	% solubility in water at 20° C	Consolute temperature, ° C	% solubility at consolute temperature
Propionitrile		88	48.3
Methyl acetate	24.4	108.5	32.5
Methyl ethyl ketone	22	150	45
<i>n</i> -Butyric acid		-3	39.5
<i>iso</i> -Butyric acid	19.4	24.5	38
<i>n</i> -Butyl alcohol	80	122.15	32.5
<i>iso</i> -Butyl alcohol	7.8	132	36.8
<i>sec</i> -" "	22	113	35.7
Phenol "	8.0	66	34
<i>o</i> -Chloro-phenol	c 2	173	33
" " "	c 2	130.8	32
<i>p</i> -" "	c 2	129	38
<i>o</i> -Nitro-phenol	1	200	
" " "	"	98.7	33
<i>p</i> -" "	"	91.6	38.3
<i>o</i> -Cresol	2.6	162.8	39.2
" " "	2.3	147	35.5
<i>p</i> -" "	2	143.5	34
Aniline	3.43	167.5	46.16
<i>iso</i> -Amyl alcohol	3	187.5	36.6

TABLE III
Increase of Consolute Temperature by Substituents in Phenol

	<i>ortho</i>	<i>meta</i>	<i>para</i>
Cl	107	65	63
NO ₂	134	33	26
CH ₃	97	81	77.5

The effect of a mutually soluble substance on partially miscible liquids is to lower their consolute temperature and, below this, to increase their mutual solubilities. A substance soluble in one only of a pair of miscible liquids may reduce their miscibility, e.g. hexane and ethyl alcohol are miscible, but addition of a small amount of water dissolves in the ethyl alcohol and renders it immiscible with

the hexane. On the other hand, soaps lower the consolute temperature of water with amyl alcohol, phenol, cresol, or aniline to below room temperature, so that these systems become completely miscible at room temperature (Fig 4). Immiscible liquids, however, behave differently when a third substance is added. When soap is added to oil and water, a stable emulsion is formed, not a homogeneous system. Before, however, we consider the nature of emulsions, we must consider the properties necessary for the third substance to have any effect upon the mixture.

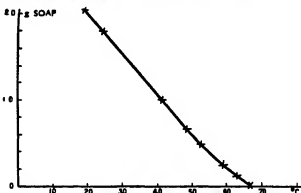

Fig 4 Lowering of consolute temperature of phenol and water by sodium stearate

Surface Activity and Adsorption.

Certain substances lower markedly the surface tension of water. They are therefore named 'surface-active'. For this they need to be *hetero-polar*. To cause surface activity they must contain a strongly polar group which roots itself in the water with its non-polar residue sticking up in the air (Fig 5). The formation of a layer of this sort is called 'adsorption'. It is obvious that all partially miscible substances will be of this type to some extent. For a liquid *A* to be soluble in *B*, it must contain a group which is 'philic'¹ to *B* and also a residue which is 'phobic'² to *B*. Without the latter the two would be completely miscible. If we consider the solubility of homologous series such as the fatty acids and alcohols in water, we see the effect of gradually increasing the size of the non-polar residue. When small in the lower members of the series, the liquids are completely miscible. As it increases, the solubility falls and the intermediate members are partially miscible. The higher members are insoluble (Tables IV and V). It should be noted, though, that the higher members can still form surface films since their polar group retains its property of dissolving in a water surface although it cannot carry the molecule as a whole into solution in bulk. Molecular weight is not the only factor involved as we see by comparing solubilities of a family of isomers (Table V).

Traube has pointed out that in a homologous series the surface activity, that is the lowering of surface tension at a given concentration, rises markedly and regularly as we ascend the series. From this it is easily shown that the amount of work required to bring a molecule (of any given homologous series) from the surface layer into the interior of the solution increases linearly with molecular weight. This has been interpreted as meaning that the molecules lie with their chains in the plane of the surface. The conclusion is not necessary and is unsupported by all the other evidence of surface films which favours the arrangement shown in Fig. 5 at high concentrations.

¹ 'Phobic' and 'philic' from Greek words for 'hating' and 'loving'

TABLE IV
Solubility of Homologous Series at Room Temperature

No of C atoms	Alcohols C _n H _{2n+1} OH	% solubility	Acids C _n H _{2n+1} COOH	% solubility
1	methyl	miscible	formic	miscible
2	ethyl		acetic	
3	propyl		propionic	
4	butyl	8.4	butyric	4
5	amyl	very small	valeric	
6	hexyl		caproic	small
7	heptyl	↓	oceanic	0.24
8	octyl		caprylic	0.25
9	nonyl	insoluble	pelargonic	very small
10	decyl		capric	"
12	dodecyl	"	lauric	insoluble
14	tetradecyl	"	myristic	"
16	hexadecyl	"	palmitic	"
18	octadecyl	"	stearic	"

TABLE V
Solubility of Isomers

	Solubility % at 20° C
n-Butyl carbinol	2.36
iso-Butyl "	2.85
sec-Butyl "	3.18
tert-Butyl "	3.74
Methyl n-propyl carbinol	4.86
Diethyl "	5.61
Methyl iso-propyl "	6.07
Dimethyl ethyl "	12.15

(P. G. Ginnings and R. Baum [4, 1937])

Gibbs' Adsorption Equation.

The amount of adsorption, Γ , at the surface of a solution can be calculated from the fall of surface tension with concentration. The equation is

$$\Gamma = -c \frac{d\sigma}{dc} \frac{dc}{dP}$$

where c is concentration, σ surface tension, and P the osmotic pressure. For dilute solutions, by van't Hoff's law,

$$\frac{dP}{dc} = RT,$$

so that

$$\Gamma = -\frac{c}{RT} \frac{d\sigma}{dc}$$

Adsorption may be negative, that is, the surface layer will be poorer in solute than the bulk of the solution. Surface tension rises with concentration. This occurs with many inorganic salts in water, but the rise is always small. Several attempts have been made to estimate experimentally the amount of adsorption, of which the work of McBain on soap solutions is most reliable. He found about twice as much as is required to form a close-packed monolayer of vertical molecules [1, 1928].

The behaviour of a heteropolar substance at a surface will depend also upon the 'polarity' or 'activity' of the polar group. Both of these terms are rather vague, but an accurate measure of this activity can be obtained from the work of adhesion to water. Tables VI and VII give the work of cohesion for various groups and the work of adhesion to water [5]. The lowness of the work of cohesion of acids and alcohols is no doubt due to their being associated in pairs by their polar groups. On water this association is broken down and the active group 'roots' itself in the water surface according to Fig. 5. The greater the

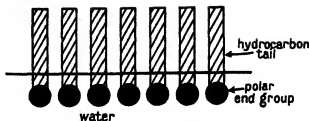

FIG. 5. Surface film

work of adhesion to the water, the smaller will be the resultant surface tension of the system. Dupré [3, 1869] has pointed out that the work of adhesion of two liquids in contact, W_{ab} , is given by the equation

$$W_{ab} = \gamma_A + \gamma_B - \gamma_{AB}$$

When the liquids are miscible, the value of W_{ab} is equal to or greater than $\gamma_A + \gamma_B$. This is another way of stating that miscibility is the case where the specific adhesion of a molecule of A or of B to those of its own species is no longer greater than the attraction by those of the opposite species. There is no longer differentiation of cohesion and the molecules move freely across a boundary until it no longer exists.

TABLE VI

Work of Cohesion, Adhesion, and Spreading Coefficients on Water

Liquid	$W_c (-2\sigma)$	$W_a (\sigma_1 + \sigma_2 - \sigma_{12})$	Spreading coefficient ($W_a - W_c$)
Heptylic acid	56.6	94.8	38.2
Octyl alcohol	55.1	91.8	36.7
Aniline	83.2	109.6	26.4
Chloroform	54.3	67.3	13.0
Carbon tetrachloride	53.3	54.4	1.1
Ethyl sodide	49.8	62.7	12.9
Benzene	57.7	66.63	8.9
Hexane	36.8	40.1	3.3
Heptane	40.2	41.9	1.7
Octane	43.5	43.8	0.3
Carbon bisulphide	62.8	55.8	-7.0

For homologous series, the effect of increasing hydrocarbon chain in decreasing hydrophilicity is shown clearly.

TABLE VII
Spreading Coefficients

Me alcohol	50.1	m-Xylene	6.19
Et "	50.4	p- "	6.70
Pr "	49.1	Ethyl benzene	5.59
Bu "	48.3		
iso-Bu "	48.2	Formic acid	35.5
iso-Amyl alcohol	44.3	Acetic "	45.2
n-Octyl "	37.74	Butyric "	45.66
sym-Octyl "	37.32	iso-Valeric acid	43.89
		Heptylic "	37.12
Benzene	8.94	Undecylic acid	32
Toluene	6.84	Oleic acid	24.62
o-Xylene	6.85		

Interfacial Tension and Adsorption.

Interfacial tension depends on both parts of the molecule because the part which is 'phobic' to water is usually 'philic' to the other liquid. At an oil/water interface we should not expect a substance such as glycerol to be strongly adsorbed, since it has little affinity for the oil phase. On the other hand, long chain or complex ring molecules which

contain both water-soluble groups and oil-soluble residues are very efficient in lowering the interfacial tension of oil/water interfaces. They are more efficient at the oil/water interface than they are at the solution/air interface, where the air has no special affinity for the hydrocarbon part of the molecules. Table VIII shows the comparative effects of long-chain alkyl sulphates [9, 1936]

TABLE VIII

	Concentration	Surface tension against air	Interfacial tension against oil
Sodium octyl sulphate	0.1 M	33 dynes	6.0 dynes
" decyl "	0.1 M	5.0 "	4.0 "
" dodecyl "	0.01 M	23 dynes	4.0 "
" tetradecyl sulphate	0.001 M	36 "	4.0 "

Here the greater efficiency of the members containing the longer chains is shown by the smaller concentration required to produce results as low or lower. Donnan and Potts [2, 1910] determined the lowering of interfacial tension of solutions of the sodium soaps of the lower homologous fatty acids against hydrocarbon oil.

Table IX shows their results, water alone being taken as unity

TABLE IX

Acid	Relative interfacial tensions	
	M/400	M/200
Acetic	0.997	0.998
Propionic	0.994	0.977
Butyric	0.994	0.977
Valeric	0.995	0.980
Caproic	0.994	0.976
Cocainic	0.990	0.964
Caprylic	0.965	0.894
Pelargonic	0.959	0.862
Capric	0.908	0.796
Lauric	0.784	0.538
Myristic	0.590	

A small amount of oil-soluble, water-insoluble polar substance in the oil may have marked effects in reducing the interfacial tension still further. The following table shows the interfacial tensions of oil against water and against soap solution with increasing amounts of oleyl alcohol in the oil. It will be seen that, after the initial effect, further addition of oleyl alcohol has little effect.

TABLE X

Oleyl alcohol, %	Interfacial tensions	
	Oil/water solution	Oil/soap solution
0.0	47.89 dynes	10.75 dynes
2.5	20.90 "	5.58 "
5.0	19.09 "	5.28 "
6.0	18.87 "	5.22 "
10.0	20.21 "	5.17 "
20.0	19.10 "	5.38 "
55.0	16.10 "	5.24 "
70.0	15.47 "	
85.0	14.68 "	
100.0	14.40 "	4.83 "

Speakman and Chamberlain [10, 1933]

Emulsions.

When we are dealing with two liquids which are immiscible, addition of a surface active substance does not con-

vert them to a homogeneous mixture as in the case of partially miscible substances, but forms instead an emulsion. In the ideal case an emulsion is a stable liquid system; homogeneous, though on a much larger scale than molecular homogeneity. The following table shows the distribution of particle size of oil droplets in an emulsion of octane stabilized by soap [5]

TABLE XI

Diameter, μ	Number of drops	%
0.5	1,889	29.38
1.5	2,296	33.71
2.5	1,161	18.06
3.5	528	8.21
4.5	303	4.71
5.5	116	1.80
6.5	64	1.00
7.5	34	0.53
8.5	12	0.19
9.5	14	0.22
10.5	2	0.03
Total		97.84

We cannot prepare emulsions of any desired particle size. The factors upon which the size depends are not known, since no theory of emulsions has been put forward. Nor, indeed, has any attention been given to the theoretical aspects of this important subject. Many emulsions depart from the ideal case in that their emulsifying layer has a definite mechanical rigidity. In these cases a much wider range of particle size can be realized so far as the rigidity overcomes the normal equilibration of forces acting at the surfaces of the droplets in more labile systems.

On standing, emulsions "cream". That is, the oil drops segregate until a layer is formed in which they are close-packed, that is a content of the order of 74%. Of course, creaming does not occur if the dispersion medium is itself rigid as are many colloidal solutions used as emulsifiers. The droplets retain their spherical form because of the residual interfacial tension. This is quite small of the order of a few dynes usually. Rarely, emulsions are formed where the interfacial tension is much larger because there is no emulsifying agent present. In this case the droplets are much smaller and the total content is always small. They are parallel to hydrophobic solids.

Now since the stability of an emulsion depends upon the presence of an adsorbed layer soluble in one liquid only (or in neither), it is clear that partially miscible liquids cannot be expected to form stable emulsions. If their interfacial tension is already low, adsorption will not occur at all. If their mutual solubility is more than a quite small amount, any emulsifier added will be soluble in both, which means that any emulsions formed will be unstable.

Hartley [7, 1937] has recently discussed the problem of the stability of emulsions. He starts from the soap micelle and considers the effect of addition of oil to its interior. The work of Pickering [8, 1907] and others has shown that oil is dissolved in the interior of the soap micelle in water. There is, however, a definite limit to the amount dissolved in this manner. The writer has suggested that the saturation value is the point at which further swelling of the micelle would separate the polar groups forming its exterior to such an extent that the interfacial tension would start to rise. This saturation value is of the order of 1.5 g. oil per g. soap [6, 1937]. Between this and the emulsion, which is of the order of 30 g. oil per g. of soap, there is a region of insta-

bility. Again, above the optimum particle size, the emulsion is not stable. Hartley considers the vapour pressure of a liquid added to the micelle, regarding the latter as a paraffin in bulk with which the added substance forms an ideal solution. The interfacial tension of the droplet causes an increase of vapour pressure which is largest for smallest droplets. When the radius of the droplet becomes larger than the length of the emulsifier molecule, the solution is no longer homogeneous, as the hydrocarbon chains of the emulsifier are held at the interface by the adhesion of their polar groups to the exterior water phase. This constraint will further increase the vapour pressure. From these considerations a composite curve is obtained which predicts stability of emulsion over a limited range of particle size. The original paper should be consulted.

We may note that for stability the emulsifying agent should not be soluble in both phases. This does not invalidate Hartley's treatment, since the substance needs to be amphiphatic to both phases, that is, part of the molecule will be soluble in each the hydrocarbon chain in oil and the $-\text{COONa}$ group, or whatever it is, in the water. It has been noted by several workers and formulated as a rule by Bancroft that the external phase of an emulsion is the liquid in which the emulsifier is soluble as a whole, while it is insoluble in the interior phase, merely being 'philic' to it. Addition of substances which make the emulsifier soluble in both phases decrease the stability of the emulsion. Oil-in-water emulsions stabilized by soaps are cracked by addition of alcohols. The rule stated above has limitations, since many substances can act as efficient emulsifiers without being soluble in either phase, e.g. calcium soaps and finely divided precipitates such as carbon and copper carbonate.

The viscosity of emulsions is anomalous, that is, as the rate of shear is decreased, the apparent viscosity increases. This is because shearing deforms the droplets and work is done against the residual interfacial tensions. Application of the usual equations to calculate the viscosity assumes that all the work is used in shearing the system. At low rates of shear the amount of this work used in deforming the drops becomes a larger and larger proportion of the total work, so that the flow decreases very much more rapidly than the shearing force.

Interfacial Tension—Liquid Solid. Wetting and Detergence.

In wetting and detergence problems we have to deal frequently with interfacial tension between solutions and solids. The actual problems are sometimes quite similar to those of emulsification when the problems arise from contamination of the solid surfaces by fatty matter. Detergence is then the problem of removing this fatty matter, an efficient insecticide needs to wet contaminated surfaces and to spread over them. In both cases there must also be efficient wetting of the cleansed surface. In some important cases, such as flotation separation of minerals, we are concerned with a clean mineral surface which needs to be contaminated by a suitable amphiphatic substance. The results given in Tables VI and XII show the marked differences of adhesion to mercury and to water, the groups most polar to mercury being generally those which are best for mineral flotation. Much work has been done on the chemistry of synthetic wetting substances, and a useful account has been given recently of these substances. The polar groups can be placed in three classes

- 1 $-\text{CO}$, $-\text{OH}$, SH
- 2 $-\text{CN}$, $-\text{CNS}$, $-\text{NO}_2$, $-\text{NH}_2$
- 3 $-\text{SO}_2\text{H}$, $-\text{SO}_3\text{H}$, $-\text{PO}_3\text{H}_2$, $-\text{PO}_3\text{H}$, $-\text{OS}_2\text{O}_3\text{H}$

The remainder of the molecule which gives it adhesion to fatty or paraffin matter is a hydrocarbon chain or a ring-system, the members of which may be benzene, pyridine, or corresponding hydrogenated rings. In the case of the bigger ring systems, such as cholesterol, substitution of polar groups in the ring may further increase amphiphatic efficiency. A very complete description of wetting agents has been given by H. K. Dean in the Leather Trades Chemists' Association Report on *Wetting and Detergence*, 1937.

TABLE XII

Work of Cohesion and Adhesion and Spreading Coefficients Organic Liquids on Mercury

Liquid	W_c	W_a	Spreading coefficient
Water	145.6	173.8	28.2
Ethyl alcohol	44.8	134.4	89.6
Methyl iodide	70.0	207.0	137.0
Benzene	57.8	147.7	89.9
Hexane	36.8	116.4	79.6
Carbon disulphide	62.8	171.4	108.6

Surface Tension of Solids.

The surface tension of a solid cannot be measured directly. Young's picture suggests that the values will be high compared with the values for liquids. From Dupré's equation (p. 1371), we have for a solid/liquid interface

$$W_{EL} = \gamma_{EL} + \gamma_{LS} - \gamma_{ES}$$

Where there is an angle of contact, θ , we have the relation

$$\gamma_{EL} = \gamma_{ES} + \gamma_{LS} \cos \theta$$

From these two equations the surface tension of the solid can be eliminated, and we get the very important relation

$$W_{EL} = \gamma_{LS}(1 + \cos \theta),$$

or

$$\cos \theta = \frac{W_{EL}}{\gamma_{LS}} - 1$$

The angle of contact therefore depends upon the adhesion of the liquid to the solid and upon the internal cohesion of the liquid itself. If W_{EL} is zero, the liquid is attracting the solid as much as itself. This is, of course, the case of complete wetting. If there were no interaction solid/liquid, then θ would be 180° . This limiting case is never realized. The sort of values found are

Water on glass	0°
Water on paraffin wax	105°
Mercury on glass	$c. 140^\circ$
" " steel	154°
" " amalgamated copper	0°

Ore flotation depends upon the fact that a particle of ore will float if it has a high angle of contact with water. Froth provides a convenient means of increasing the air surface and of removing the separated ore from the unwanted residue which must be wetted by water and will then sink to the bottom. In practice, therefore, we require a water/air surface-active substance to produce a more or less permanent froth when air is blown through the water, a solid/water surface-active substance to make the unwanted residue wetted by water and, possibly, another solid/water surface-active substance to make the ore less easily wetted. The substances used will depend upon the nature of the surfaces of the substances to be separated.

Two main points emerge from this discussion. First that

very small amounts of suitable surface-active substances can modify or entirely change the properties of an interface. The greater the disparity between the surfaces the greater will be the effect of such a substance. And, secondly, a surface-active molecule must contain a polar group to attach itself to the polar phase and a non-polar one for the

non-polar phase. These molecules must be larger than a fairly sharply defined minimum size because the influence of the polar group extends a certain distance over the non-polar part. The influence of any particular substance can be predicted from physico-chemical knowledge of the groups in question and of the interfacial surfaces.

REFERENCES

- 1 Colloid Symposium Monographs (1928)
- 2 DONNAN and POTTI *Kolloid Z* 7, 208 (1910)
- 3 DUPRÉ *Théorie Mécanique de la Chaleur*, 369 (1869)
- 4 GINNING, P G., and BAUM, R *J A C S* 59, 1111 (1937)
- 5 HARKINS *J A C S* Numerous papers since 1916
- 6 LAWRENCE, A C S *Trans Faraday Soc* 33 815 (1937)
- 7 Leather Trades Chemists' Association *Report on Wetting and Detergence* (1937)
- 8 PICKERING, S U *J C S* 91, 2001 (1907), *ibid* 111, 86 (1917)
- 9 REED, R M., and TARTAR, H V *J A C S* 58, 322 (1936)
- 10 SPEAKMAN, J B., and CHAMBERLAIN, N H *Trans Faraday Soc* 29, 358 (1933)

BIBLIOGRAPHY

- ADAM, N K *The Physics and Chemistry of Surfaces* (1930)
 CLAYTON *Emulsions* (1935)
 FREUNDLICH *Colloid and Capillary Chemistry* (1926)
 Leather Trades Chemists' Association Symposium on Wetting and Detergence, *Report*, 1937
- RIDGAL, E K *Surface Chemistry* (1930)
 CLAYTON has also published a remarkable list of patented emulsifiers in *Technical Aspects of Emulsions* (1935)

THE APPLICATION OF PHYSICAL METHODS TO THE ANALYSIS OF HYDROCARBON MIXTURES

By MARIUS L. I. T. AUBERT

Master of Conferences, Faculty of Science, University of Paris

OWING to the numerous cases of isomerism afforded by mixtures of hydrocarbons, the question arises in the determination and the measurement of the concentration of the various constituents of gasolines, whether a complete analysis is possible. Generalizing a method introduced by Darmois in the study of the phenomena of rotary polarization it can be shown theoretically that the problem can be solved, and further, that by practical application of the method our knowledge of certain properties of hydrocarbons will be increased.

Consider a sample of oil of mass M . A complete analysis of this necessitates the determination of

- The number, p , of the constituents c_1, c_2, \dots, c_p
- The nature of these constituents
- Their respective masses m_1, m_2, \dots, m_p

Determination of the Number p of the Constituents.

Let A be the quantity which serves to characterize the behaviour of a mixture with reference to a certain given phenomenon.

When the various constituents of this mixture are without chemical action upon one another, as is the case with hydrocarbons, A is found to be a linear function on the one hand, of the coefficients a_1, a_2, \dots, a_p relating to the phenomenon under consideration for the p constituents, and on the other hand, of the relative concentrations c_1, c_2, \dots, c_p of these constituents in the mixture, each constituent influencing the total effect of the whole in proportion to its mass concentration.

The mixture satisfies, then, an additive rule which may be represented in the following form

$$A = \sum_1^p a_i c_i + a_0 c_0 + \dots + a_p c_p$$

This additive rule applies to hydrocarbons in the case of magnetic rotary polarization [1], ordinary rotary polarization, absorption of various infra-red or ultra-violet rays, specific refraction, refractive dispersion, &c. The relative coefficients which apply equally to the mixture or its constituents are then, respectively, the specific magnetic rotation, the specific rotation, the specific coefficient of absorption, the specific refraction of Gladstone and Dale or Lorentz-Lorenz, &c.

Since the equations are linear at the same time both in relation to a_i and to c_i , it is possible to determine the number p of the constituents.

The method will be shown for a specific case from which it is easy to generalize.

Suppose it to be necessary to show that a mixture L which distils between the temperatures t_1 and t_2 contains three constituents, L_1, L_2 , and L_3 . It will be assumed that there are three constituents and three only, and the relation which would then hold between certain measured quantities will be found on the basis that this assumption is true. By distillation this is divided into four mixed fractions, $M, M', M'',$ and M''' , distilling respectively in the temperature intervals $(t_1, \theta), (\theta, \theta'), (\theta', \theta'')$, and (θ'', t_2) , the temperatures $\theta, \theta', \theta''$

being included in the interval $t_1 - t_2$. There are now four mixed fractions in which the concentrations of the three constituents will be different.

It will be shown that, on condition that three determinations satisfying the law of additivity are made upon each of the four fractions there exists, of necessity, a relationship between the twelve results obtained experimentally.

For the first phenomenon which conforms to the conditions imposed determinations for the four mixtures lead to equations of the following form

$$\begin{aligned} A &= a_1 c_1 + a_2 c_2 + a_3 c_3 \\ A &= a_1 c_1 + a_2 c_2 + a_3 c_3 \\ A &= a_1 c_1' + a_2 c_2' + a_3 c_3' \\ A &= a_1 c_1'' + a_2 c_2'' + a_3 c_3'' \end{aligned} \quad (1)$$

where the various facts satisfy by definition the equations

$$\sum c = \sum c' - \sum c'' = 1 \quad (2)$$

Now the equations (1) are compatible whilst considering a_1, a_2, a_3 as unknowns whence

$$\Delta = \begin{vmatrix} A & c_1 & c_2 & c_3 \\ A & c_1 & c_2 & c_3 \\ A' & c_1' & c_2' & c_3' \\ A' & c_1' & c_2' & c_3' \end{vmatrix} = 0 \quad \left| \begin{array}{ccc|c} A & c_1 & c_2 & 1 \\ A & c_1 & c_2 & 1 \\ A' & c_1' & c_2' & 1 \\ A' & c_1' & c_2' & 1 \end{array} \right|$$

in virtue of

$$\sum c = 1$$

This determinant, developed in relation to the elements of the first column, takes the form

$$Ad - Ad + A'd'' - A'd' = 0,$$

where d, d', d'', d''' represent the corresponding minors. If now two other series of physical determinations, involving phenomena still following the additive rule, are made on the preceding fractions, equations analogous to the above will be obtained. Finally we shall have

$$\begin{aligned} Ad - Ad + A'd'' - A'd' &= 0, \\ Bd - Bd + B'd'' - B'd' &= 0, \\ Cd - Cd + C'd'' - C'd' &= 0, \end{aligned}$$

the minors d, d', d'', d''' remaining the same. To these three equations the following can be added

$$d - d' + d'' - d' = 0$$

Δ becomes zero from relation (2) when $A, A', A'',$ and A''' are replaced by 1. The four equations homogeneous in d, d', d'', d''' and d'' being satisfied for values of d not completely null, this becomes

$$D_3 \begin{vmatrix} A & A & A' & A' \\ B & B & B' & B' \\ C & C & C' & C' \\ 1 & 1 & 1 & 1 \end{vmatrix} = 0 - \begin{vmatrix} A - A' & A' - A'' & A'' - A''' \\ B - B' & B' - B'' & B'' - B''' \\ C - C' & C' - C'' & C'' - C''' \end{vmatrix}$$

which is the equation sought for between the twelve experimental determinations upon the four fractions. It follows that if such an equation is true for the quantities measured that the number of constituents in the mixture will be three.

It is clear that all the minors of D_3 must not be quite alone unless the mixtures contain two constituents only. In this case the formula

$$D_3 = 0$$

is reduced to the very simple expression below, which is obtained by considering three fractions and making two series of determinations only

$$D_3 = \begin{vmatrix} A-A'' & A'-A'' \\ B-B'' & B'-B'' \end{vmatrix}$$

or

$$\frac{A-A''}{B-B''} = \frac{A'-A''}{B'-B''}$$

which is nothing more than the rule given by Darmois

For a mixture containing p constituents, $p(p+1)$ experimental determinations are necessary

In the case of a complex mixture, a gasoline for example, it is advantageous to work upon distillates which only contain a small number of constituents—two or three—so that the number of operations is reduced and greater accuracy is assured

Determination of the Nature of the Constituents.

At the present time the characteristic Raman frequencies are known for over one hundred pure hydrocarbons. The Raman spectra of the mixtures M , M' , M'' , M''' will enable, in many cases, identification to be made of the hydrocarbons contained in these fractions [2]

On account of the number of isomers, there will always be some hydrocarbons for which Raman spectra cannot be obtained. On some occasions, therefore, it will only be possible to identify a number p' of the hydrocarbons, p' being lower than p . However, several general rules have been evolved. Consideration of certain frequencies relative to an unknown body can give valuable information on its

constitution—whether, for example, the hydrocarbon contains a double or triple bond, whether it is acyclic, cyclic, or aromatic, and, in the last instance but one, the number of carbon atoms in the ring

From examination of the absorption spectra in the infra-red [3] it is possible to confirm certain conclusions drawn from the Raman spectra, and in the case of paraffin hydrocarbons to show whether the hydrocarbon is of straight-chain or branched-chain structure. Occasionally magnetic birefringence measurements [1] will afford further support to conclusions drawn from the previous methods, particularly in the case of aromatic hydrocarbons

Determination of the Masses of the Constituents Present.

The hydrocarbons having been identified, the coefficients a_1 , b_1 , c_1 which figure in the equations

$$\begin{aligned} A &= a_1 c_1 + a_2 c_2 + a_3 c_3 \\ B &= b_1 c_1 + b_2 c_2 + b_3 c_3 \\ C &= c_1 c_1 + c_2 c_2 + c_3 c_3 \end{aligned}$$

are then known. The solution of system 1.1 gives the concentrations c_1 , c_2 , c_3 of the three constituents L_1 , L_2 , L_3 considered in the mixture M . Operating in the same manner on the equations A' , B' , &c., c_1 , c_2 , c_3 , then c_1' , c_2' , c_3' and finally c_1'' , c_2'' , c_3'' are calculated, i.e. the concentrations of these same constituents in the mixtures M' , M'' , M''' . The composition of each of these mixtures having been determined, that of the initial mixture L is immediately forthcoming

REFERENCES

- 1 See the article by M. Scherer 'The Application of Magnetic-Optical Properties in the Analysis of Hydrocarbon Mixtures', p. 1220
- 2 For the practical application of Raman spectra to hydrocarbon mixtures, see the article of M. Andant 'Analysis of Petroleum Spirits using the Raman Spectrograph', p. 1213
- 3 See the article by M. Lecomte 'The Application of Infra-red Absorption Spectra to the Study of Petroleum Oils and Spirits', p. 1196

CORRELATION OF THE PHYSICAL PROPERTIES OF PETROLEUM

By K. M. WATSON, Ph.D., A.I.C.E.

Chemical Engineer, Universal Oil Products Company

The following correlations have been developed to permit estimation of the approximate physical behaviour of a petroleum fraction or hydrocarbon from the limited number of inspection data ordinarily available in industrial practice. It is believed these relationships are sufficiently accurate for ordinary engineering usage, but it must be emphasized that exact correlation is as yet impossible because of the complexity of the materials under consideration. Where accuracy is desired, a direct and accurate determination for a particular stock is always preferable to an approximation based on average behaviour.

Basic Inspection Data

In order to form a basis for the prediction of more difficultly measurable properties, the interrelationships between the inspection data commonly available will be considered first. For prediction of physical behaviour it is necessary that at least two of the six following properties be known from actual laboratory determination of the particular stock under consideration.

1. Specific Gravity.

Since specific gravity is the most readily determined of all physical properties, its value is generally available. The A.P.I. scale is extensively used in petroleum technology, and all gravity relationships will be expressed in these units. Specific gravities at 60° F are readily converted into degrees A.P.I. by the tables on pp 1130-1132.

2. Average Boiling-point.

For the lower-boiling petroleum fractions Engler distillation data are usually determined in all routine inspections. To use these data as a basis for physical correlations it is necessary to develop a method of calculating an average boiling-point which may be satisfactorily related to other average properties when working with mixtures of wide-boiling ranges.

The ideal method for calculating the average boiling-point should be such that when other average properties are constant the average boiling-point is independent of width of boiling-range. For example, consider a series of fractions prepared from a stock of uniform characteristics, such as a Mid-Continent or Pennsylvania crude, such that all fractions have the same specific gravity but are of different widths of boiling-range. Experience has shown that the average molecular weights of such fractions are substantially equal, and it is desirable that a method of averaging be developed to give also equal average boiling-points.

The averaging of boiling-point data on a weight or volume basis does not satisfactorily meet the above requirement. As width of boiling-range is increased, the average boiling-point calculated on either a weight or volume basis increases, even though the specific gravity, average molecular weight, and chemical type are constant. The average on a volume basis shows much less variation than on a weight basis and is preferable for that reason. The 50% temperature in the Engler distillation is frequently a close

approximation to the average boiling-point on a volume basis if the distillation curve is symmetrical.

In an attempt to improve correlations for wide-boiling mixtures Watson and Nelson [18, 1933] suggested a *molal average boiling-point*, weighting the distillation temperatures on a molal basis. This average would be obtained by averaging the ordinates under a curve relating molal of distillate to temperature. It was found that this molal average boiling-point is less affected by width of boiling-range than a volumetrically weighted average.

For convenient estimation of the molal average boiling-point from ordinary Engler data the upper curve of Fig 1 was prepared. A temperature correction to be subtracted

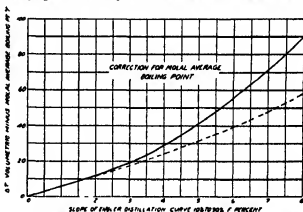

FIG 1 Average boiling-point. Upper curve molal average, lower curve best average for physical correlations.

from the volumetric average boiling-point in order to obtain the molal average is plotted against the slope of the Engler distillation curve between the 10% and 90% points.

Experience with very wide-boiling range fractions has shown that, although the upper curve of Fig 1 gives a fair approximation to correct molal average boiling-points, the corrections indicated are somewhat too great for the ideal average described above. Apparently this ideal average is intermediate between the volumetric and molal values. The lower curve of Fig 1 is an empirical estimate of the correction to be subtracted from the volumetric average boiling-point in order to obtain the best average for physical correlations.

The volumetric average boiling-point is satisfactorily taken as the average of the temperatures at which the distillate plus loss equals 10, 30, 50, 70, and 90% by volume of the Engler charge. This average, corrected from Fig 1, has been found satisfactory for fractions having distillation curve slopes of 5 or less. For wider boiling mixtures, particularly of unsymmetrical distillation curves, erratic results may be obtained, but no better method is available at present.

It is, of course, important that no decomposition should take place in the distillation from which the average boiling-point is calculated by the above method. For higher boiling fractions a vacuum distillation, converted to an atmospheric pressure basis, is required. If decomposition is

suspected in the last part of the distillation, the best approximation is obtained by taking the 50% temperature as the volumetric average boiling-point and basing the correction from Fig. 1 on the slope from 10% to 50%.

In all the following correlations, 'average boiling-point' refers to the average obtained in the above manner, using the lower curve of Fig. 1. For close-cut fractions, having slopes of 2 or less, this correction may generally be neglected and the 50% temperature taken as the average boiling-point.

3. Viscosity.

For correlation with other properties, viscosity measurements should be made at as high a temperature as possible, particularly in the case of heavy oils. At low temperatures the viscosity is influenced by width of boiling-range, crystallization, and colloidal phenomena which result in erratic deviations from relationships with other average properties. Viscosities measured at 210° F are ordinarily satisfactory for all stocks, and good results may be obtained with measurements as low as 100° F on stocks of the light gas oil or kerosene range.

Because of the limited range of each of the industrial viscosimeters, it is highly desirable that viscosities be expressed in the fundamental unit of kinematic viscosity, the centistoke. The kinematic viscosity in centistokes is equal to the viscosity in centipoises divided by the specific gravity at the temperature of measurement.

Calibrations have been determined for converting readings of all industrial viscosimeters to centistokes. Any of these instruments of suitable range may be used. However, the most satisfactory results are obtained with a capillary type such as the Ostwald pipette or the modified Ubbelohde viscosimeter recently proposed by Fitzsimmons [7, 1935].

4. Viscosity Index.

Viscosity index, as defined by Dean and Davis [5, 1929], is frequently a convenient basis for establishing the character of fractions of the lubricating range. The viscosity index is determined by viscosity measurements at two temperatures as described in the article by P. Docksey entitled 'Viscosity Index and Viscosity Gravity Constant', p. 1091.

5. Aniline-point.

The aniline-point has been used to a considerable extent as an index to the character of hydrocarbon mixtures. Determinations are difficult on heavy, dark-colored oils, limiting the useful application of this method to distillates.

Two methods of determining aniline-points are commonly used. One is the temperature of complete miscibility of equal volumes of aniline and the oil in question. The more satisfactory method determines the critical solution temperature by measuring a series of miscibility temperatures for different proportions. The aniline-points here referred to are critical solution temperatures, although in many cases the difference between the two methods is slight.

6. Hydrogen Content.

The hydrogen content, in per cent, by weight, is one of the best indexes to the general character or paraffinicity of a stock. However, because of the difficulty of the determination, this information is seldom available and is more frequently sought as a result than used as a means of correlation and prediction of other properties.

Interrelations of Basic Inspection Data

Characterization Factor.

The problem of general correlation of average physical properties for stocks of widely different types is considerably simplified by any quantitative means of expressing the general character of the oil. Paraffin hydrocarbons, of maximum hydrogen content, may be considered as one extreme and aromatic materials of minimum hydrogen content as the other.

To serve as a quantitative index to this property, which may be termed 'paraffinicity', the UOP characterization factor has been developed and empirically related to the six inspection results enumerated above. Although this factor is not an exact measure of chemical type and does not show perfect constancy in a homologous series, these disadvantages are, to a considerable extent, offset by its simplicity and convenience of definition and use.

The definition of the UOP characterization factor arose from the observation that when a crude oil of supposedly uniform character is fractionated into narrow cuts, the specific gravities of these cuts are approximately proportional to the cube roots of their absolute boiling-points. The proportionality factor may then be taken as indicative of the paraffinicity of the stock. Thus

$$K = \frac{\sqrt[3]{(T_B)}}{S} \quad (1)$$

where K = UOP characterization factor,

T_B = average boiling-point, °R = °F + 460,

S = specific gravity at 60° F.

This factor shows fair constancy throughout the boiling-range of a number of crude oils, and for others may either increase or decrease in the higher boiling-range. In the paraffin series fair constancy for the average of the reported isomers exists up to a boiling temperature of 700° F. Values of the characterization factor range as follows:

Pennsylvania stocks	12.2-12.5
Mid-Continent stocks	11.8-12.0
Gulf Coast stocks	11.0-11.5
Cracked gasolines	11.5-11.8
Cracking plant combined feeds	10.5-11.5
Recycle stocks	10.0-11.0
Cracked residuums	9.8-11.0

The characterization factor is readily calculated from equation (1) from only the specific gravity and average boiling-point. It may be read directly from A.P.I. gravity and average boiling-point by interpolation between the curves of Fig. 2. In this figure A.P.I. gravities are plotted as ordinates and average boiling-points as abscissae with lines of constant K from equation (1).

Characterization Factor from Viscosity and Gravity.

It has been found [19, 1935] that a fair empirical correlation exists between the characterization factor and the viscosity-gravity relationship at a given temperature. Paraffin stocks have high viscosities as compared to aromatic materials of the same gravities. A viscosity-gravity constant of this type, but applicable only to the lubricating oil range, was proposed by Hill and Coates [10, 1928].

As previously mentioned, the viscosity measurements used for physical correlations should be made at as high a temperature as possible. In Fig. 3 viscosity in centistokes at 210° F. is plotted against A.P.I. gravity for stocks of constant characterization factors. By use of the centistoke

scale of viscosity the entire range of fractions from light gasolines to heavy residues is covered in a single relationship.

The curves of Fig 3 are the result of a large number of measurements on many types of stocks, both straight-run and cracked. In general, the correlation is satisfactory for

boiling-point data are more frequently available than viscosities. In this case Fig 3 may be used for estimating viscosity from boiling-point and gravity. This relationship is much more satisfactory in the low-boiling region than in the high

Figs 4 and 5 present relationships similar to those of

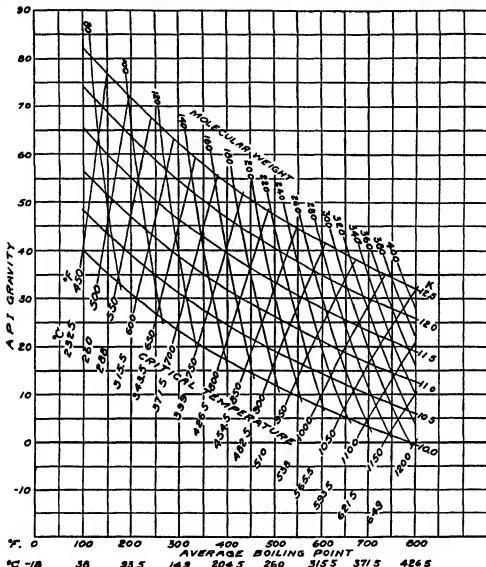

Fig 2 Characterization factor, molecular weight, and critical temperature from average boiling-point and gravity

estimating the characterization factor to within plus or minus 0.1 unit from a given specific gravity and viscosity.

Lines of constant boiling-point are plotted on Fig 3 resulting from combination of the relationships between characterization factor from boiling-point and viscosity data. These lines permit an approximation to the boiling-point from only viscosity and gravity data. This relationship is particularly useful in the case of heavy stocks on which boiling-point data can be obtained only under high vacuum. However, because of the rapid change in viscosity with a slight change in the gravity of heavy stocks, boiling-points estimated in this way may be considerably in error, sometimes as much as 50° F for the heavier residues.

For light stocks in the kerosene or gasoline range,

Fig 3 but based on temperatures of 122 and 100° F, respectively. These charts must be used with care, particularly on heavy stocks of wide-boiling ranges. As previously pointed out, viscosity correlations at low temperatures are uncertain and affected by many factors not influencing other average properties. The charts are based on average behaviour of stocks of typical boiling-ranges corresponding to distillation curve slopes in the range of 2 to 5. For wider or narrower boiling cuts, considerable deviation may result.

Characterization from Viscosity Index.

Since viscosity index is generally interpreted as an indication of the character of a lubricating oil, a relationship should exist between it and the characterization factor

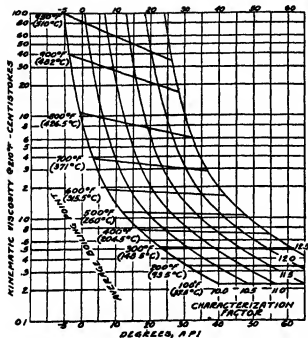

FIG 3 Characterization factor from viscosity at 210° F

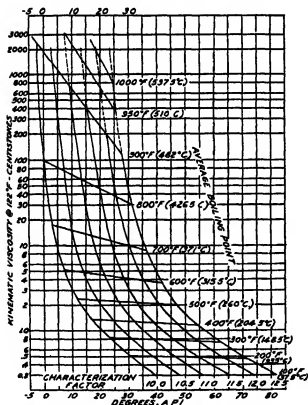

FIG 4 Characterization factor from viscosity at 122° F

This general relationship is indicated by the upper curve of Fig 6

Because of the effect of width of boiling-range and other factors on viscosities at 100° F., the viscosity index is not a good method of characterization unless these factors are relatively constant. For example, a Mid-Continent

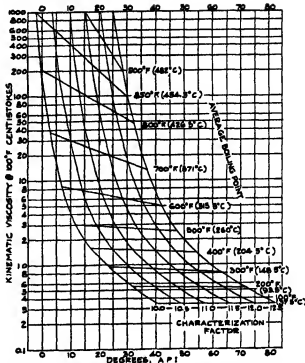

FIG 5 Characterization factor from viscosity at 100° F

lubricating oil may have a characterization factor of 11.9 and a viscosity index of 65. By blending only 5% of a light Mid-Continent naphtha, also having a characterization factor of 11.9, with this oil the viscosity index is increased to nearly 100. Thus, viscosity index is a good indication of character only when the width of boiling-range is constant. However, for ordinary lubricating oils the boiling-range is sufficiently narrow that this effect is negligible, and the curve of Fig 6 is a good approximation.

Characterization from Aniline-point.

Aniline-point has been extensively used as a method of characterization on the general theory that paraffinic materials have aniline-points higher than those of unsaturates or aromatics. However, it has been found that boiling-point, width of boiling-range, and probably some other factors enter into the relationship between aniline-point and other physical properties.

The lower curves of Fig 6 represent an approximate correlation between aniline-point, characterization factor, and average boiling-point. However, the relationship is rather rough and considerable deviation may result in either direction on some stocks.

Hydrogen Content.

It was pointed out by Sweeney and Voorhees [15, 1934] that the hydrogen content of a petroleum fraction may be estimated as a function of average boiling-point and gravity. The curves of Fig 7 represent a similar relationship, plotting hydrogen content against characterization factor for materials of constant boiling-points. The extrapolation of the existing data by this method of plotting leads to results for low-boiling materials of low characterization factor which are considerably different from those of the plot of Sweeney and Voorhees. Their plot is more consistent with the properties of benzol and its low-boiling

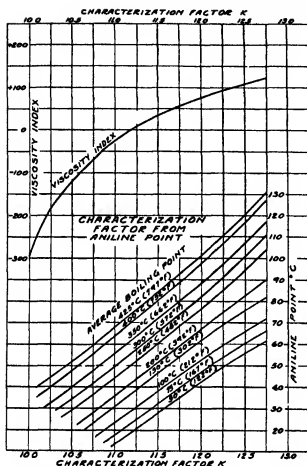

FIG 6 Characterization factor from viscosity index or aniline point

homologues, but Fig 7 appears to agree somewhat better with measurements on highly cracked stocks. More data are necessary in the regions of disagreement before an entirely reliable plot can be determined. Fortunately, for the types of stocks ordinarily encountered, the agreement is good.

Fig 7, combined with the preceding charts, permits estimation of hydrogen content from a knowledge of only the specific gravity and one other property. Ordinarily the error will be less than 0.5%, based on the total weight of the oil, except in the cases of the highly aromatic, low-boiling materials mentioned above.

Molecular Weights

The molecular weights of petroleum fractions may be satisfactorily estimated from average boiling-point and gravity. Aromatic stocks of low characterization factors have lower molecular weights than paraffinic materials of the same average boiling-points.

The relationship between molecular weight, characterization factor, boiling-point, and API gravity is included in the curves of Fig 2. The molecular weight curves were based on published values and other data available to the Universal Oil Products Company. By interpolation between these curves, molecular weights may be estimated with errors rarely exceeding 5%. If boiling-point data are not available, the boiling-point may be estimated from other properties, using Figs 3-7.

Critical Properties

Critical Temperature.

A relationship between critical temperature, boiling-point, and gravity was proposed by Watson [17, 1931] for all pure compounds of the non-polar type. It was found that this equation was in close agreement with the published data on a great variety of compounds of this type, ranging from the lightest gases to the heaviest liquids. The same equation is also in good agreement with the published results of Eaton and Porter [6, 1932] and others on petroleum fractions.

Because of the wide range of proven applicability of the basic equation, it is considered the most sound available basis for correlating and extrapolating the measurements which have been made on petroleum fractions. The critical temperature curves of Fig 2 were calculated directly from this equation but are in satisfactory agreement with the data on petroleum. The critical temperatures estimated by interpolation between the curves of Fig 2 agree closely with the similar plot proposed by Eaton and Porter except in the very high boiling-point region, where the equation leads to a somewhat different extrapolation.

Measurements on wide-boiling mixtures of petroleum fractions, even including hydrocarbon gases, indicate that if the ideal average boiling-point described above is used, the critical temperature is little affected by width of boiling-range. Thus critical temperatures estimated from Fig 2 are directly applicable to pure hydrocarbons, narrow petroleum cuts, or wide-boiling mixtures.

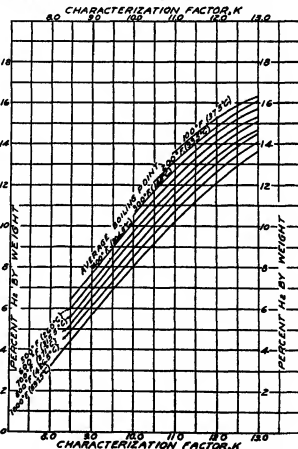

FIG 7 Hydrogen contents of petroleum fractions

Critical Pressure.

The critical pressure of a pure compound is readily estimated by extrapolating its vapour-pressure curve to the critical temperature and reading the corresponding pressure. The complete vapour-pressure curve of any hydrocarbon may be estimated from its boiling-point or a single determination of vapour pressure by use of the vapour-pressure chart of Brown and Coats [2, 1928].

The curves of Fig 8 were derived directly from the Brown-Coats vapour-pressure chart, and relate the critical

Thermal Expansion and Compressibility**Expansion.**

Many correlations of thermal expansion have been proposed, most of which were based on only the specific gravity of the stock. The unsoundness of this basis is made apparent by comparison of the properties of benzol and octane, which happen to have very similar expansion characteristics. Benzol has a gravity of 30° API and a boiling-point of 175° F, while the corresponding properties

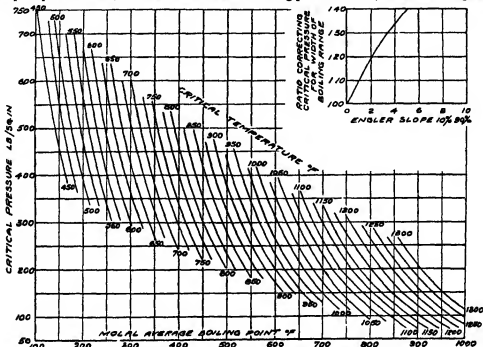

Fig 8 Critical pressure of pure hydrocarbons and petroleum fractions

pressures of pure hydrocarbons to their boiling-points and critical temperatures estimated from Fig 7. Aromatic compounds have higher critical temperatures and pressures than paraffinic materials of the same boiling-points.

Measurements on both petroleum fractions and simple mixtures of pure compounds indicate that the critical pressures of mixtures are much higher than would be predicted by any method of averaging the critical pressures of the components. Frequently the critical pressure of the mixture is higher than that of any component present. This effect may be expressed as a relationship between width of boiling-range and critical pressure.

The small correction curve plotted in the upper corner of Fig 8 shows a correction factor by which the critical pressure of a pure compound is multiplied in order to obtain that of a mixture of the same average boiling-point, gravity, and critical temperature. This correction factor is related to the slope of the Engler distillation curve. For example, a petroleum fraction having an Engler distillation curve slope of 3.0 will have a critical pressure approximately 27% higher than a pure compound of the same boiling-point and critical temperature.

The data on critical pressures of mixtures are few, and much additional work is necessary before a universally applicable and rigorous correlation is possible. The above method is in fair agreement with the available data and forms a convenient means of general approximation which seems to be as accurate as possible at present.

of octane are 69° API and 256° F. In general, aromatic fractions expand much more than paraffinic fractions of the same gravities and somewhat less than paraffinic fractions of the same boiling-points. The latter basis would be preferable if expansion data were to be correlated against a single property.

Jessup [11, 1930] and Thiele and Kay [16, 1933] have recently improved the correlation of expansion data by taking as a basis two properties, the viscosity and gravity. The principle disadvantages of this method are that it is based on Saybolt Universal viscosities, making it difficult to apply to low-boiling stocks, and that it offers no sound basis for extrapolation of expansion data to high temperatures.

It was found that a still more satisfactory correlation may be obtained on the basis of critical temperature. Data on both pure compounds and petroleum fractions indicate that, in general, materials having the same critical temperatures show almost identical expansion characteristics.

The curves of Fig 9 were plotted on this basis, making use of the available data on pure compounds and petroleum fractions for estimating thermal expansion under the critical pressure. The extrapolations out to the critical temperature were based on critical volumes calculated from the molecular weight and critical data of the preceding sections. The calculation was made using the simple gas laws with a compressibility factor of 0.25 for the critical point.

Fig. 9 permits satisfactory approximation of the thermal expansion of any type of stock, independent of characterization factor or gravity. The critical temperature is readily estimated from Fig. 2, and any two of the basic inspection data are available for the stock.

It is believed that the relationships of Fig. 7 are little

at higher temperatures or for extremely high pressures the values from Fig. 9 must be corrected if the pressure is different from the critical pressure.

The compressibility characteristics of a substance at its critical temperature may be estimated from the curves of Brown, Souders, and Smith [3, 1932] giving deviations

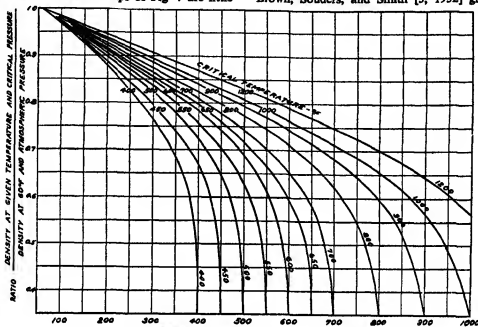

Fig. 9 Thermal expansion of liquid petroleum fractions under their critical pressures. For effect of pressure see Fig. 10.

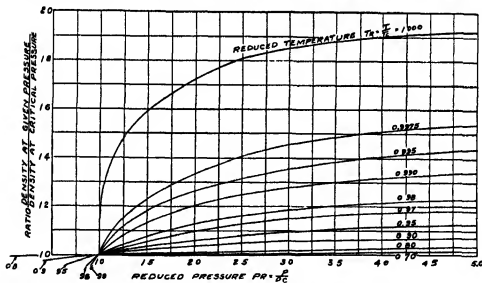

Fig. 10 Compressibility of liquid petroleum fractions

affected by change in width of boiling-range. Wide-boiling mixtures have higher critical pressures, but the deviations from the simple gas law in the critical region are less by a compensating amount.

Compressibility.

The effect of moderate changes in pressure on the volumes of liquid oils is small at temperatures well below the critical. Referring to Fig. 9, where the temperature is such that the density ratio is greater than 0.75, the effect of pressure may be neglected for many purposes. However,

from the perfect gas law, or compressibility factors. On this basis the upper curve of Fig. 10 was plotted, giving a factor by which the density of a substance at its critical point must be multiplied to obtain densities at other pressures. This factor is expressed as a function of reduced pressure. For example, a hydrocarbon at its critical temperature and a reduced pressure of 2.0, twice the critical pressure, will have a density 72% greater than if it were under its critical pressure.

The lower curves of Fig. 10 express the effect of pressure on density at temperatures below the critical. These curves

were established by interpolation between the critical temperature curve and curves corresponding to lower temperature compressibility measurements based on the data of Jessup and other data available to the Universal Oil Products Company

The curves of Fig 10 express a general correlation of compressibility data which is satisfactory for ordinary

Specific Heats—Vapour State.

The specific heats of petroleum vapours of Mid-Continent stocks have been thoroughly investigated by Bahlke and Kay [1, 1929], Weir and Eaton [20, 1932], and Gary, Rubin, and Ward [8, 1933] with excellent agreement over wide-temperature ranges. On the basis of these data and

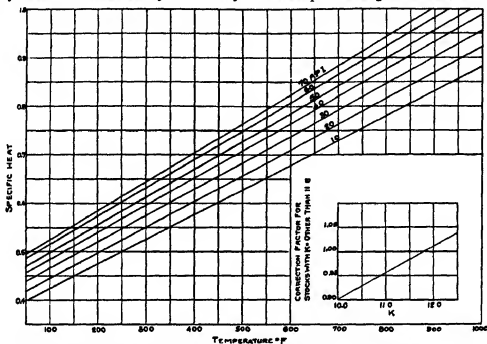

Fig 11 Specific heats of petroleum fractions of 11.8 characterization factor. For other stocks multiply by corrections from lower curve

purposes except in the region very close to the critical point where all density predictions become uncertain. There is evidence that this relationship is not greatly dependent upon width of boiling-range for the same reasons cited in the discussion of Fig 9.

Thermal Properties

Specific Heats—Liquid State.

The subject of specific heats of liquid hydrocarbons and petroleum fractions was recently reviewed by Gaucher [9, 1935], with the conclusion that the relationship developed by Watson and Nelson [18, 1933] is the most generally satisfactory yet proposed for the data existing at this time. This correlation expresses specific heat as a function of specific gravity, temperature, and characterization factor according to the following equation:

$$c_p = [0.6811 - 0.308s + t(0.000815 - 0.000306s)] [0.055K + 0.35]$$

where c_p = specific heat at $t^\circ F$,
 s = specific gravity at $60/60^\circ F$,
 t = temperature, $^\circ F$,
 K = U O P characterization factor

Fig 11 is a plot of the above equation for convenient use. The curves on the main plot apply directly to Mid-Continent stocks whose characterization factors are approximately 11.8. For other stocks the value read from the main plot is multiplied by a correction factor derived as a function of K from the small plot in the lower right-hand corner.

those available on pure compounds, the following general equation was proposed by Watson and Nelson:

$$c_p = \frac{4.0 - s}{6450} (t + 670)(0.12K - 0.41),$$

where c_p = specific heat at $t^\circ F$,
 s = specific gravity at $60/60^\circ F$,
 t = temperature, $^\circ F$,
 K = U O P characterization factor

This equation is that proposed by Bahlke and Kay for Mid-Continent stocks with an added correction for characterization factor. Its results are in fair agreement with the data of the investigators cited above and also with data on pure compounds.

In Fig 12 specific heats, calculated from the above equation for Mid-Continent type petroleum vapours, are represented by the lower curves of the main group, designated according to API gravities. The upper curves of the main group, designated by gas specific gravities referred to air as 1.0, represent the data on the paraffin gases. These curves were estimated from the available measurements extrapolated to be consistent with the data on petroleum fractions. For petroleum vapours other than Mid-Continent types of 11.8 characterization factor, the values read from the chart are multiplied by a correction factor from the small curve in the lower right-hand corner.

Latent Heat of Vaporization.

The experimental data published on the latent heats of vaporization of petroleum fractions are discouragingly contradictory. It is difficult to account for the wide varia-

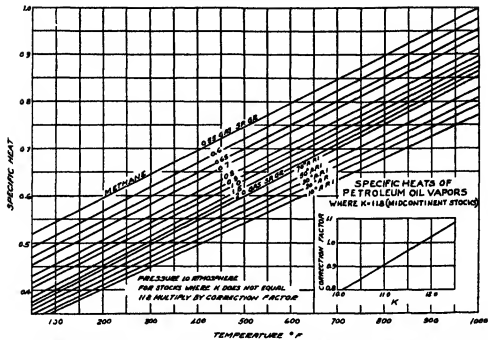

FIG 12 Specific heats of petroleum vapours of 11.8 characterization factor For other stocks multiply by correction from lower curve

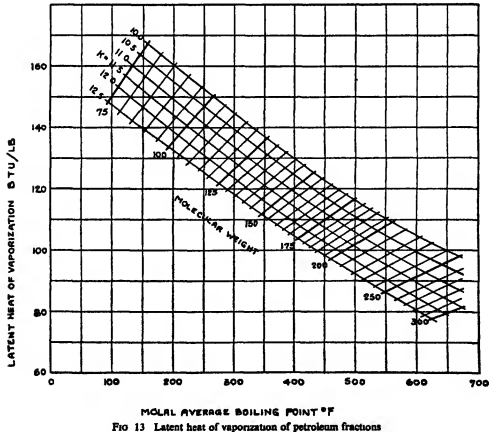

FIG 13 Latent heat of vaporization of petroleum fractions

tions reported, frequently amounting to greater than 50% differences in similar stocks

Because of the unsatisfactory state of the direct experimental data, it is considered preferable to adopt the best theoretical method for estimating latent heats. This is believed to be the equation of Kistyakowski [12, 1923] described by Watson and Nelson. This equation accurately represents all data on non-polar pure compounds and is said to be thermodynamically sound.

The curves of Fig 13 were plotted directly from the Kistyakowski equation, using the molecular weight relationships of Fig 2. Latent heats of vaporization are related to average boiling-points, molecular weights, and characterization factors.

The latent heats read from Fig 13 are considerably higher than proposed by Cragoe [4, 1929] as representing the best average of the published values. However, the more recent data of Weir and Eaton are in good agreement

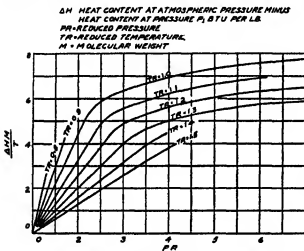

FIG 14 Pressure correction to heat content (Joule-Thomson effect)

with Fig 13, while those of Gary, Rubin, and Ward are still higher

Effect of Pressure on Heat Content (Joule-Thomson Effect).

A simple means of correcting heat contents of gases and vapours for the effect of pressure was proposed by Watson and Nelson. Patee and Brown [14, 1934] more recently studied this property experimentally and found considerable

deviation from the Watson and Nelson predictions. However, they concluded that this method is as accurate for petroleum mixtures as any then proposed and preferable because of its simplicity.

In a recent paper by Newton and Dodge [13, 1935] a new method of calculating Joule-Thomson effects based on activity coefficients is proposed. The results of this method appear to be in excellent agreement with experimental values. It is probable that a method of this type will prove to be a considerable improvement after opportunity is offered for its study and adaptation.

The chart of Watson and Nelson is reproduced in Fig 14. The correction to be subtracted from heat content in changing from atmospheric to an elevated pressure is expressed as a function of reduced temperature, reduced pressure, molecular weight, and temperature. Since these corrections are relatively small, the results of the chart are satisfactory for most engineering purposes.

Total Heat Contents.

The total heat content of a petroleum fraction either liquid or vapour at any temperature or pressure in the range covered may be calculated from the above charts. The heat content at atmospheric pressure and the desired temperature is first calculated and this value corrected for the effect of pressure by means of Fig 14.

It may be assumed that the fraction is heated as a liquid to its average boiling-point, vaporized at this temperature and superheated as a vapour to the final temperature. The errors of this assumption are ordinarily negligible. Where only partial vaporization exists, the heat contents of the liquid and vaporized portions are best treated separately.

Total heat contents of vapours calculated in this way are somewhat lower than those experimentally observed by both Weir and Eaton and Gary, Rubin, and Ward for cracked stocks. However, in the case of the former investigators the contributing discrepancy lay in the specific heat of the liquid state while in the latter it is in the latent heat of vaporization. Conversely, the specific heat of liquid data here proposed is in good agreement with those of Gary, Rubin, and Ward, while the latent heat data are in good agreement with Weir and Eaton. For this reason it is felt that additional data will be required to justify change in these relationships.

For convenient use it is preferable to prepare heat-content charts applying to stocks and pressures of particular interest. Such charts are readily prepared from the above data.

REFERENCES

- 1 BAHLEK, W. H., and KAY, W. B. *Ind Eng Chem* 21, 942 (1929)
- 2 BROWN, G. G., and COATS, H. B. *A Vapour Pressure Chart for Hydrocarbons*. Dept Eng Research, University of Michigan, Circular Series no 2 (Dec 1928)
- 3 BROWN, G. G., SOUTHERS, M., and SMITH, R. L. *Ind Eng Chem* 24, 513 (1932)
- 4 CRAGOE, C. S. *Bur Stds Misc Pub* 97 (1929)
- 5 DEAN, E. W., and DAVIS, G. H. B. *Chem Met Eng* 36, 618 (1929)
- 6 EATON, G. L., and PORTER, C. A. *Ind Eng Chem* 24, 819 (1932)
- 7 FITZGERALD, O. *Ind Eng Chem. Anal. Edit* 1, 345 (1935)
- 8 GARY, W. W., RUBIN, L. C., and WARD, J. T. *Ind Eng Chem* 25, 178 (1933)
- 9 GAUCHER, L. P. *Ind Eng Chem* 27, 57 (1935)
- 10 HILL, J. B., and COATES, H. B. *Ind Eng Chem* 20, 641 (1928)
- 11 JESSUP, R. S. *Bur Stand J Res* 5, 985 (1930)
- 12 KISTYAKOWSKI Z. *Physik Chem* 107, 65 (1923)
- 13 NEWTON, R. H., and DODGE, B. F. *Ind Eng Chem* 27, 577 (1935)
- 14 PATEE, E. C., and BROWN, G. G. *Ind Eng Chem* 26, 511 (1934)
- 15 SWENNEY, W. J., and VOORHEES, A. *Ind Eng Chem* 26, 197 (1934)
- 16 THURLE, E. W., and KAY, W. B. *Ind Eng Chem* 25, 894 (1933)
- 17 WATSON, K. M. *Ind Eng Chem* 23, 360 (1931)
- 18 WATSON, K. M., and NELSON, E. F. *Ind Eng Chem* 25, 880 (1933)
- 19 WATSON, K. M., NELSON, E. F., and MURPHY, G. B. *Ind Eng. Chem* 27, 1460 (1935)
- 20 WEIR, H. M., and EATON, G. L. *Ind Eng Chem* 24, 211 (1932)

SECTION 21
GENERAL ANALYSIS AND TESTING OF PETROLEUM
PRODUCTS

The Laboratory Testing of Petroleum Products Gasoline, White Spirit, Kerosine, and Gas Oil	A W NASH and F C HALL
The Laboratory Testing of Lubricating Oils	A W NASH and F C HALL
Methods for the Analysis of Fuel Oil	F B THOLE
General Methods of Analysis of Waxes	W J WILSON and R E DOWNER
Testing of Asphaltic Bitumen	J S JACKSON
General Methods of Analysis of Transformer Oils	A R STARK
Cable Oils	C CHILVERS
The Analysis of Greases and High-pressure Lubricants	C A FOSLER

THE LABORATORY TESTING OF PETROLEUM PRODUCTS: GASOLINE, WHITE SPIRIT, KEROSENE, AND GAS OIL

By Professor A. W. NASH, M.Sc., M.Inst.P.T., and F. C. HALL, Ph.D., A.M.Inst.P.T.

Department of Oil Engineering and Refining, University of Birmingham, England

The purpose of laboratory testing can be broadly divided into three sections—research, refinery plant control, and the selection of a petroleum product for some specified purpose. The methods used in routine laboratory testing are simplified to the greatest degree consistent with the accuracy required, to facilitate their convenient and rapid execution. The chemical nature of petroleum is so complex and the number of component substances so great that, with few exceptions, the analytical methods employed in its examination do not attempt to give any exact chemical analysis of the material under consideration.

The correct selection of a petroleum product for any given purpose is of the greatest importance to both consumer and producer. The object of laboratory testing methods in this connexion is to facilitate this without the necessity of actual trial of the product under consideration. This selection can be carried out by testing to a specification, in which the object is to produce an article substantially the same in essential characteristics as one which has already been found satisfactory. For this purpose the value of certain characteristics of the product are specified to which limits the product under examination must conform. Theoretically it is not necessary for the specified properties to bear any relationship to those needed for the purpose in question, provided that they suffice satisfactorily to duplicate the product under consideration. In practice, however, it is necessary to include in specifications a number of tests which have a greater or less bearing on the conditions to be met with in service. The tendency has been to seek a more correct interpretation of such tests and to eliminate those which have little significance in favour of new or modified tests which can more correctly express the value of a petroleum product for its proposed utilization. Under these circumstances, specification tests become a more logical basis for the comparison and evaluation of different products, the permissible limits can be more satisfactorily defined, and the specification itself assumes a far greater significance.

In the succeeding sections the methods available for the laboratory testing of the more important petroleum products are summarized, and their significance and importance discussed. For laboratory details of the procedure involved in the testing methods described, reference should be made to the standard publications listed in the following section, and to the original papers given in the subjoined references. The following select list of manuals may also be consulted.

The Examination of Petroleum Hamor and Padgett (McGraw-Hill Book Co., New York, 1920)

Handbook of Petroleum, Asphalt, and Natural Gas, Cross (Kansas City Testing Laboratory, Kansas City, 1931)

The Tag Manual (C J Tagliabue Mfg Co., Brooklyn, N.Y.)

Petroleum Refinery Engineering Nelson (McGraw-Hill Book Co., 1936)

Hydrocarbon Oils and Saponifiable Fats and Waxes Holde, trans Mueller (John Wiley & Sons, New York, 1922)

Kohlenwasserstoffe und Fette, 7th ed Holde (Julius Springer, Berlin, 1933)

Handbook of the Petroleum Industry, 1. Day (1922)

Motor Fuels, their Production and Technology Leslie (Chemical Catalog Co., New York, 1923)

The Principles of Motor Fuel Preparation and Application, 2. Nash and Howes (Chapman & Hall, London, 1935)

Lubrication and Lubricants, 2nd ed Archbutt and Deeley (Griffin & Co., London, 1927)

Lubricating and Allied Oils, 2nd ed Evans (Chapman & Hall, London, 1933)

The Standardization of Testing Methods.

In the early history of the petroleum industry there existed little standardization of the testing methods employed. The natural result was that satisfactory comparison and correlation of petroleum characteristics, as determined by different laboratories, was almost impossible, and a considerable amount of confusion was caused from the multiplicity of testing methods in use. This was particularly marked on account of the arbitrary nature of many of the tests carried out, the results obtained being expressive of no definite physical or chemical property of the product, but dependent on the method of operation of the test and on the design of apparatus employed. The necessity of standardization has long been recognized, but long-established custom and an individualistic outlook still hinder complete international standardization. In this connexion a tribute must be paid to the American Society of Testing Materials for their pioneering work, the value of which has been recognized by other standardization bodies who have, in many cases, adopted the A.S.T.M. testing methods with little or no modification. The question of international co-operation in the standardization of petroleum-testing methods was discussed at the World Petroleum Congress of 1933, at which a general survey of the position, with particular regard to liquid fuels, was given by Dr A. E. Dunstan (see *Proc World Petr Cong 1933*, 2, 903-17).

The following list shows the institution or association which has undertaken the task of issuing standardized methods of testing for petroleum products in the principal oil-producing and consuming countries (with the exception of Russia). It should be borne in mind, however, that a standardization committee has, in general, no power to compel the adoption of its standard methods by the producers and users of petroleum products.

United States of America.

The American Society for Testing Materials (A.S.T.M.) (1315 Spruce Street, Philadelphia, Penn.). Publication.

A S T M Standards on Petroleum Products and Lubricants, reprinted from the *Book of A S T M Standards*, Part 11 (1936)

Great Britain.

The Institution of Petroleum Technologists (I P T) (Aldine House, Bedford Street, Strand, London, W C 2) Publication *Standard Methods for Testing Petroleum and its Products*, 3rd ed., 1934

Germany.

Deutscher Verband für die Materialprüfungen der Technik (D V M.) (Berlin, N W 7 Dorotheenstrasse 40) Publication Standard methods for testing lubricants—*Prüfung von Schmiermitteln*—designations D V M 3651—D V M 3661 Issued separately Specifications, Testing Methods, and Significance of Tests for Lubricants, published as *Richtlinien für Einkauf und Prüfung von Schmiermitteln*, 6th ed., 1933 Standardization of tests for light spirits, kerosenes, fuel oils, &c., are under consideration

France.

Association Française de Normalisation (A F N O R) (23, rue Notre-Dame des Victoires, Paris (2^e)) Publication Standard methods for light spirits—*Produits Blancs*—designations A F N O R B 6-11—B 6-15, for lubricants—*Huiles et Graisses*—A F N O R B 6-21—B 6-32

Belgium.

Association Belge de Standardisation (A B S) (Rue Ducale, 33, Brussels) Publication Specifications and methods of testing of lubricants—*Échantillonnage et Analyse des huiles de graissage et des graisses lubrifiantes* Rapport no 52 (Oct 1933, 1st ed)

Italy.

Commissione Tecnica Governativa degli Oli Minerali (Milan, Via Marina 5) Publication *Norme Italiane per il controllo degli Oli Minerali e Derivati, combustibili liquidi, oli isolanti e lubrificati*, Bitumi, 2nd ed., 1928 Revised standards are under consideration (see *Oli Minerali*, 13 (3), 33, (4), 49, (5), 65, (6), 84 (1933))

International.

Committee on Nomenclature and Methods of Testing Petroleum Products and Lubricants, of the International Standards Association (I S A Technical Committee, No 28)

The Sampling of Liquid Petroleum Products

The correct sampling of petroleum oils for laboratory testing is of the utmost importance, the most carefully carried out series of tests is invalidated if the laboratory sample is not truly representative of the bulk of the material from which the sample was taken and of which the characteristics are required. Comprehensive directions for sampling are given in the manuals listed in the bibliography, the following being a brief summary of the more important points. It must be understood that no set of directions, however explicit, can take the place of judgement, skill, and experience on the part of the persons engaged on the sampling

Sampling should be carried out under conditions allowing no contamination by rain or dust, and all sampling apparatus, containers, and the operator's hands, should be scrupulously clean and dry

Sufficient quantity of the sample should be taken to enable the required tests to be carried out in duplicate together with any referee tests, and to admit of a portion being retained by the laboratory. In general at least one quart is desirable

The samples should be placed in clean containers, of glass or tinplate, and closed with corks or metal stoppers, specially refined oils are placed in glass-stoppered bottles, all glass containers being protected from the light. Each sample must be labelled with all relevant data immediately after taking

Sampling from Tanks, Drums, &c.

With small containers the contents may be thoroughly mixed before sampling and a 'mixed sample' obtained, otherwise samples may be taken from the lower, middle, and upper layers of the liquid in the tank. These may be separately investigated, or mixed in the correct proportions to give a 'composite sample'. An 'all level' sample is taken by allowing the sampling device to fill while being drawn from the bottom to the top of the liquid

In the case of semi-solid products or wax-containing oils, the material may be warmed till homogeneous. If water is present a bottom sample is taken to determine the amount of separated water, and in this connexion the possibility of separation of alcohol blends must be borne in mind

In the case of natural gasolines and other volatile liquids precaution is necessary to avoid evaporation losses and the immersion method of sampling is preferable. The sampling bottle is cooled in ice before use, and the resulting sample kept in ice during storage and transport

The sample may be obtained by the 'bottle' or 'thief' methods, the former is applicable to large tanks and consists of a sample bottle, weighted and corked, the cork being attached to the suspension cord or to a separate line. The bottle is lowered to the required depth in the oil, the cork jerked out, and the bottle withdrawn. Metal sampling thieves are available of similar design, or else capable of sampling at any distance from the bottom by an automatically controlled valve (Fig 1)

A thief which may conveniently be used for smaller tanks, &c., consists essentially of a large metal pipette of uniform diameter and about 3 ft long. The thief is filled by immersion to the required depth and release of the pressure at the upper end, a similar device is capable of taking an average sample from top to bottom of the tank. Larger samples may be withdrawn by use of a suction bottle and long tube.

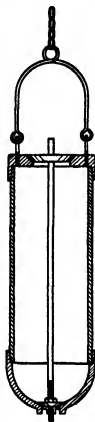

FIG 1 Thief for sampling liquid products

Sampling from a Flowing Oil Stream.

If the oil is flowing through a pipeline, a 'continuous sample' may be taken by means of a by-pass system, as described in the I P T and A S T M directions. An 'inter-

mittent sample' may be similarly obtained from a by-pass cock in the main line, or else—in the case of an open stream—by introduction of a dipper or collecting bowl into the flowing oil.

SELECTED BIBLIOGRAPHY

A S T M *Standards on Petroleum Products and Lubricants*, 1936, p. 250, Designation D 270-33
I P T *Standard Methods of Testing Petroleum and its Products*, 1934, p. 1, Serial Designation—S 1

Standard Methods for Testing Tar and its Products, 1929, p. 3
German Standard Method, D V M 3651—Sampling of Lubricating Oils, &c.
DAY, D. T. *Handbook of the Petroleum Industry 1*, 590 (1920)

GASOLINE

Progress in the design of internal-combustion engines and the introduction of new methods in gasoline manufacture and refining necessitate the more rigid definition of motor-fuel characteristics than formerly. The terms gasoline and petrol, although more generally applied to hydrocarbon spirits produced from petroleum, include low-temperature carbonization and hydrogenation spirits, coal-tar benzole, methyl and ethyl alcohols, and diverse blends of these. Other components which may be present in relatively small proportions include stabilizing agents (in alcohol blends), anti-knock dopes (lead tetraethyl), gum inhibitors, and dyes.

Although special testing methods may be introduced for the latter components, and for alcohol and benzole blended fuels, the evaluation of a gasoline free from suspended water and foreign matter, as regards its engine performance, may be satisfactorily carried out on the basis of the distillation and knock-rating tests. Correct interpretation of the distillation test will indicate the ease of starting and acceleration characteristics of the fuel, and the possibility of crankcase dilution of the lubricating oil. The power development from the fuel and its ability to withstand high-compression ratios may be estimated from the distillation test and from the knock rating. The latter test provides the necessary information on the suitability of the chemical nature of the gasoline constituents. In the case, however, of alcohol fuels, the question of power development, at least, is complicated by the opposing factors of low calorific value and high latent heat, the latter leading to improved volumetric efficiency. Such fuels have a high knock rating and are capable of withstanding high engine compression ratios with the minimum tendency towards detonation and excessive production of heat.

The vapour pressure of a gasoline is of importance in that, for a given engine design and operating temperature, it governs the possible occurrence of vapour lock in the fuel-supply lines. Although the vapour pressure may be estimated from the distillation test, it is more conveniently and accurately obtained by direct measurement.

The degree of refining of the motor fuel and its freedom from objectionable constituents may be determined from the amount present of gum-forming components, of deleterious sulphur compounds, and of corrosive materials. The inclusion of specific gravity in gasoline specifications is of questionable value, except in the case of aviation gasolines. The colour may be regarded entirely as a marketing consideration. In the case of alcohol-blended fuels, special tests are necessary for the determination of physical stability. These include both a cold test and the determination of their water tolerance. A cold test

may also be applied to benzole fuels and is of particular importance if such fuels are intended for aircraft purposes.

The specification limits adopted for the different methods of test will naturally depend upon the purpose for which the fuel is required. Aviation gasolines demand the highest standards while commercial vehicles and stationary engines are adequately supplied by fuels of considerably lower grade. Specifications of different gasolines are discussed under the appropriate section.

Knock Rating

The determination of the knock rating of gasolines is discussed in detail by Campbell and Boyd (p. 149). The C F R Motor Method is standardized under A S T M Designation D 357-36 T, and under I P T Serial Designation G 39 (7).

Distillation

The volatility, as determined by distillation, is the most important single characteristic of a gasoline to be used as a motor fuel. The standard distillation test for gasolines and light spirits is based on Engler's method. The only fractionation is that taking place in the neck of the flask and, of a consequence, the test does not give exact information on the boiling-points of the different constituents of the gasoline. By careful standardization of the apparatus and procedure, however, the method is capable of giving very reproducible results with simplicity and convenience in operation. The distillation figures obtained can then be used to evaluate the volatility of the gasoline in terms of service requirements.

The apparatus and procedure used in the United States are standardized under A S T M Designation D 86-35, in Great Britain under I P T Serial Designation G 3, and in France under A F N O R B 6-11. In Germany the Engler-Ubbelohde apparatus is used, the essential dimensions of this and the previous forms being identical by international agreement.

The apparatus (Fig. 2) comprises an Engler distillation flask of normal design, supported on an asbestos plate with centre hole, and surrounded by a draught shield. Heat is applied by a gas or electric burner, preferably with micro control. A metal condenser tube, surrounded by a cooling bath, leads to a 100 ml graduated receiver. 100 ml. of the gasoline is distilled at the rate of 4.5 ml per min and the volume of distillate at definite vapour-temperature increments (or vice versa) is recorded, together with the temperature at the first distillate (the Initial Boiling-point—I.B.P.), the maximum temperature attained (End-point—E.P.), and the distillation loss. The temperature is usually recorded

in degrees Centigrade in Europe, and in degrees Fahrenheit in the United States

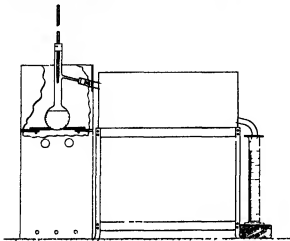

FIG 2 Distillation of gasoline

The following correction for the barometric pressure may be applied in cases of dispute

$$C_p = 0.00012 (760 - P) (273 + t_p)$$

for Centigrade readings

$$C_p = 0.00012 (760 - P) (460 + t_p)$$

for Fahrenheit readings

in which C_p and C_p are, respectively, corrections to be added to the observed temperature t_o or t_p , and P is the actual barometric pressure in millimetres of mercury. The accuracy of the distillation is such that duplicate determinations of the distillate at any temperature should agree to within 2 ml, and of the I B P and E P to within 3° C (5° F).

In the case of Natural Gasolines the high volatility necessitates a slightly modified procedure, as detailed under A S T M Designation D 216-32 and I P T Serial Designation G 3a, to avoid undue loss.

The results of the distillation test, as a measure of the volatility of the gasoline, may be conveniently expressed by the A S T M distillation curve, in which the vapour temperature in °F is plotted as ordinate against the percentage of spirit distilled off.

Significance.

The general volatility requirements of a gasoline are three in number: it should contain sufficient light ends to permit easy starting without causing vaporization in the fuel-supply line (vapour-lock) or undue evaporation loss, it should not contain any appreciable quantity of 'heavy ends' to escape efficient vaporization, causing incorrect distribution and crankcase dilution, the general volatility should lead to good acceleration and warming-up with satisfactory power development.

As related to engine performance, the volatility of a fuel may be defined as the fraction of the fuel evaporated under equilibrium conditions at a definite temperature and pressure for a given air-fuel ratio, and is then correctly determined by an equilibrium air distillation. From the work of Bridgeman [13, 1928] and Brown [16, 1930] this volatility has been effectively correlated with those performance factors mentioned and with the A S T M distillation curve. With this new significance for the distillation test, its correlation with various factors of engine performance has been achieved. These results have been summarized by Blair and Alden [9, 1933], it is found that satisfactory starting, acceleration, general performance, and tendency towards crankcase dilution, are determined by the 10, 35, 60, and 90% points respectively on the A S T M distillation curve. The 10% point can also be correlated with the Reid Vapour Pressure and Vapour-locking tendencies of the gasoline, while Blair and Alden further extend the utility of the curve to an approximate estimation of the lighter hydrocarbon components of the fuel.

The chart shown in Fig 3, upon which the A S T M distillation curve may be plotted, has been developed by Brown [18, 1931]. The axes from left to right, except the fifth, indicate the atmospheric temperatures above which the gasoline under consideration provides the following features of performance:

- (1) Possible starting (8%)
- (2) Easy starting (10%)
- (3) Quick warming-up characteristics (35%)
- (4) Good acceleration, without choke, steady driving (60%)

The fifth axis is provided with two scales. The scale on the left side indicates the atmospheric temperature at or above which crankcase dilution will only be experienced when the choke is used. The scale on the right side is an index of the atmospheric temperature above which there will be loss of power as a result of too rapid vaporization.

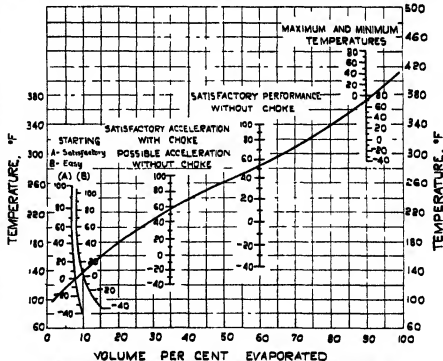

FIG 3 Relationship between volatility and performance of gasoline (Brown)

of the fuel. The distillation curve shown represents a typical U S A gasoline for the year 1930

The IBP and EP temperatures have no essential significance and, their reproducible determination being a matter of some difficulty, they are now frequently omitted in specifications

Volatility Index.

Attempts have been made to express the overall volatility characteristics of a gasoline by a simple numerical value. The Ostwald Volatility Index [80, 1926] is obtained by addition of the 5%, 15%—95% distillation temperatures and division by 10, but its utility has been questioned. Oberfell and Alden [72, 1933] find that the 35% and 60% temperatures are closely related to the 50% temperature for the majority of gasolines, and suggest that the Volatility Index should be expressed as the difference between 284° F and the 50% temperature on the A S T M distillation curve. These volatility indices have, in general, little significance when applied to alcohol and benzene-blended fuels.

Precise Distillation Analysis.

The standard Engler apparatus is unsuitable for the more precise distillation analysis of light hydrocarbon spirits, on account of the inefficient separation of the vapour components. In addition the distillation temperature recorded is incorrect. The temperature may be more accurately obtained by correction for exposed thermometer thread and by reducing radiation loss from the bulb, or alternatively by the use of a thermo-couple or platinum resistance thermometer [75, 1924].

For more effective separation of the vapour components, the introduction of an efficient fractionating column is essential (see Young [105, 1922], Leslie [56, 1923], Hill and Ferris [46, 1927]). Latterly, the introduction of extremely efficient 'true boiling-point' columns in connexion with the evaluation of crude oils has rendered possible the very exact distillation analysis of light hydrocarbon mixtures. Such columns possess very efficient packing material, are of adequate dimensions, and are run under adiabatic conditions with careful control of the reflux. Reference may be made, in this connexion, to the columns used by Bensinger and Child [7, 1930], Peters and Baker [81, 1926], and Podbielniak [82, 1931, 1933]. The efficiency of packing materials for small laboratory columns has been discussed by Fenske, Quiggle, and Tongberg [37, 1932, 38, 1934].

Vapour Pressure

The vapour pressure of a complex hydrocarbon mixture, such as gasoline, depends chiefly on the presence of the lighter components, propane, butanes, &c. These confer easy-starting characteristics on the fuel and possess high anti-knock rating, but by reason of their high-vapour pressure tend to cause vapour lock in the fuel-supply system. The vapour pressure of natural gasolines is then of considerable importance from the point of view of their blending with heavier spirits to meet seasonal marketing requirements. In addition the design of storage and transport equipment is obviously dependent to a high degree on the vapour pressure exerted by the gasoline, which may be as high as 50 or 60 lb in the case of unstabilized natural gasolines. (For correlation of Vapour Pressure with storage-tank losses, see Lewis and Coleman [57, 1931].)

From the complex constitution of gasoline, precise vapour-pressure measurement necessitates a method in which the composition of the liquid phase is not appreciably altered by formation of the vapour, in addition to elimination of the effect of dissolved gases and water. For industrial purposes, simplicity and a fair degree of reproducibility have led to the standardization of the Reid Vapour Pressure Bomb in which the total pressure, inclusive of dissolved gases and saturated water vapour, is measured. Since the ratio of vapour to liquid in this method is considerable, and varies with different gasolines of differing vapour pressure, the results obtained are quite arbitrary.

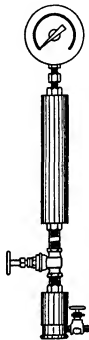

FIG. 4 Reid vapour-pressure bomb

The Reid Vapour Pressure of a gasoline is the vapour pressure in pounds per square inch exerted at 100° F by the gasoline in the Reid bomb of approved design. The apparatus and procedure have been tentatively standardized under A S T M Designation D 417-35 r, and I P T Serial Designation G 37, a modified procedure for natural gasolines being retained under A S T M Designation D 323-32 r. The apparatus (Fig 4) consists essentially of two interconnected cylindrical metal chambers, the lower one containing gasoline and the upper one gasoline vapour and air, the pressure of which is recorded by a gauge. Alternative designs permit filling either by immersion or from a pipeline. The bomb is immersed in a suitable bath at 100° F and the final observed pressure, after correction for the increase in pressure of the air and water vapour in the bomb at the temperature of measurement, is reported as the Reid Vapour Pressure of the gasoline. The results (A S T M) should duplicate to within 0.25 lb for gasolines having vapour pressures under 12 lb, and to within 0.5 lb for other products [36, 1932]. Commercial gasolines normally have vapour pressures varying from 6 to about 12 lb, but considerably higher values are shown by natural gasolines. Correct sampling and transference of the gasoline samples is of particular importance, a detailed procedure being described under A S T M Designation D 417-35 r.

Vapour-pressure bombs have been designed in which the ratio of vapour volume to liquid is extremely small, enabling results of greater accuracy to be obtained [40, 1928-9]. For the more precise laboratory determination of the vapour pressure of gasolines, reference may be made to the work of Tizard and Marshall [98, 1922], Cadman [18, 1924], Aldrich, Bridgeman, and White [3, 1929], and Brown [16, 1930]. The relationship between vapour pressure and temperature, and the effect of the relative volumes of gasoline and vapour present, are discussed by these investigators.

Correlation of Reid Vapour Pressure with the Distillation Curve and with Vapour Lock.

Bridgeman and Aldrich have shown that the true (gas-free) vapour pressure of a fuel can be correlated with the 10% point on the A S T M distillation curve together with the slope of the curve at that point, while Blair and

Alden [9, 1933] and Trumble and Richardson [99a, 1935] have evolved charts by which the Reid vapour pressure can be estimated from the distillation curve with an accuracy of about 0.5 lb.

The relation between vapour pressure and vapour lock is dependent on the design of the fuel-supply system and on the atmospheric temperature, which together determine the maximum temperature reached by the fuel stream. The temperature at which vapour lock appears is approximately that at which the vapour pressure of the fuel equals the external pressure exerted upon the fuel stream, which in turn is dependent upon the design of the fuel-supply system. According to Brown [16, 1930] this temperature (t°) is related to the vapour pressure by the equation

$$t^{\circ} = 263.4 - 140 \log (\text{Reid V.P. of dry fuel at } 100^{\circ} \text{ F})$$

Specific Gravity

The specific gravity of a gasoline may be expressed in the standard units, usually at the temperature $60^{\circ} \text{ F} / 60^{\circ} \text{ F}$. In the United States the A.P.I. scale (Baumé with 141.5 modulus) is used almost universally in the industry. The relationship between these units is given by the equation $\text{Gravity in degrees API} = (141.5 / \text{sp. gr. } 60^{\circ} / 60^{\circ} \text{ F}) - 131.5$ conversion tables being published by the U.S. Bureau of Mines.

The determination of specific gravity in the case of light spirits is dealt with elsewhere. Standard methods for this are detailed under A.S.T.M. Designation D 287-36 and I.P.T. Serial Designation G 1.

The specific gravity of a gasoline or oil is of importance commercially in the case of transportation and delivery, particularly since these products are dealt with on both a weight and volume basis. Tables for the interconversion of weight, volume, and gravity relationships are given elsewhere.

The inclusion of specific gravity in gasoline specifications, other than for aviation fuels, is to be deprecated, for its relation to service characteristics is negligible. In the case of aviation gasolines the weight of fuel carried is of importance. Consequently a fuel of low specific gravity, having a higher calorific value for a given weight, is to be preferred, other things being equal, to one of higher gravity. For straight-run spirits of the same type or of common origin, the gravity is some measure of the volatility, while for straight-run spirits of equivalent volatility the gravity is some indication of the paraffinic or naphthenic nature of the spirit. The specific gravity of a gasoline can thus be used, in conjunction with other factors, in the hydrocarbon analysis of the spirit. In the case of the cracked and blended gasolines now marketed, the gravity is of no direct significance. As a guide in

refinery technique and in the control of refinery processes (particularly distillation), specific gravity determination is of the greatest importance, being rapidly carried out and giving valuable information on the characteristics of the product.

Colour

The colour of a gasoline is no satisfactory indication of its degree of refining, nor has it any relation to the gumming tendency of the spirit or its suitability as a fuel.

The present tendency is to omit colour in gasoline specifications. It is still, however, a factor in marketing, although research has shown that the treatment frequently necessary to secure a water-white colour is both detrimental to the knock-rating of the fuel and uneconomic. At the present time the common practice is to market coloured gasolines or else to counteract any residual colour by addition of blue dye. The question of the colour stability of gasolines has been discussed by Morrell, Benedict, and Egloff [66a, 1936].

The colour of a gasoline (free from dye) is expressed in arbitrary units, related to the colour of a standard solution such as potassium dichromate or iodine.

In Great Britain the colour of petroleum distillates is determined with the Lovibond Tintometer, described under I.P.T. Serial Designation K 2. In this instrument the colour of an 18-in. column of the spirit is matched by standard coloured glasses, four of which are supplied: Water-white (1.0), Superfine-white (2.0), Prime-white (3.0), and Standard-white (4.0) together with intermediate glasses. The gasoline is contained in a horizontal trough adjacent to a holder for the coloured glass slides. These are viewed through a simple eye-piece, illumination being provided by a daylight lamp and screen. An improved form of this instrument, known as the British Drug Houses pattern, has recently been introduced.

In the United States the Saybolt Chromometer (Fig. 5), described under A.S.T.M. Designation D 156-34.7, is universally employed. The depth of a column of the

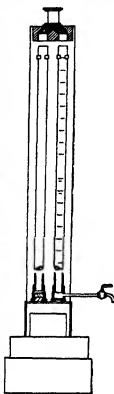

FIG. 5 Saybolt chromometer

Comparison of Colour Reading

Description	I.P.T. number	Lovibond Colour Red+Yellow	Stammer number	Saybolt number	Depth of oil layer equivalent to 404.6 mm of acidified 0.00093% $K_2Cr_2O_7$ solution
Standard White	4.0	2.5	36.0	50	46.2
" "	3.5	1.9	31.0	68	59.9
Prime White	3.0	1.4	26.0	86.5	84.9
" "	2.75	1.2	20.0	115	105.8
" "	2.5	1.0	15.0	143	140.4
" "	2.25	0.8	10.0	172	208.5
Superfine White	2.0	0.6	5.6	199	404.6
Water White	1.5	0.53	3.9	255	565.4
" "	1.0	0.46	2.3	310	957.9

gasoline is varied till its colour matches that of one-half, one, or two standard coloured glasses, the colour of the spirit is then expressed as Saybolt colour by reference to a conversion table. The spirit and coloured glasses are contained in adjacent vertical glass tubes, illuminated by a daylight lamp and viewed through a prismatic eyepiece, enabling the field of view to be divided equally and sharply between the colour standard and the spirit under examination. The Stammer Colormeter (Holde, p 232) resembles the Saybolt instrument and has been used in Germany and in America.

Tables for the interconversion of the colour readings of these different instruments and for their comparison with standard dichromate solution have been given by Day [23, 1922], Cross [22, 1931], and Holde [49, 1933]. The preceding table has been adapted from that of Holde.

Determination of Gum

'Preformed', 'Actual', or 'Existent' Gum refers to that non-volatile constituent of certain gasolines which is deposited as a gummy residue on evaporation of the spirit. It may be prevalent in cracked spirits (especially vapour-phase cracked) and can be deposited on standing at room temperature. 'Potential Gum' refers to that gum, not already present in the gasoline, which is produced on storage of the spirit. Whereas fuels containing 'actual gum' tend to deposit this in the induction system of an engine, causing trouble through sticking valves, 'potential gum', as such, has no effect on the engine and is of significance only when the gasoline is to be in storage.

Determination of Preformed Gum. The essential feature of these methods is the evaporation of a definite volume of gasoline and determination of the residue formed, the results being expressed as milligrams of gum per 100 ml of gasoline.

The copper-dish test (U S Bur Mines Tech Paper 323 B Method 530 I), in which the spirit is evaporated down in a copper dish over a steam bath, has been widely employed. The method is now in disfavour due to general lack of reproducibility and correlation with engine performance, and to interference by the presence of corrosive sulphur (see, however, Murphy and Wirth [70, 1933]). Catalytic action by the copper results in the estimation of potential as well as actual gum, the figure being consistently higher than in other methods. A gum content of 25 mgm appears to be the maximum to be tolerated in commercial gasolines when determined by this method.

Glass-dish methods, in which the effect of the copper is eliminated by the use of glass, porcelain, or silica dishes, yield more satisfactory results (see Smith and Cooke [92, 1922], Wagner and Hyman [100, 1929], Cooke [21, 1925], Story, Provine, and Bennett [93, 1929], Auld [5, 1929]). All such methods, however, require a considerable time to evaporate the spirit completely, the time is dependent upon the volatility of the spirit and introduces a distinctly variable factor. To reduce this, and to simulate more closely the conditions in an engine, accelerated evaporation tests have been introduced in which the gasoline is evaporated in a stream of air. A considerable reduction in time with negligible oxidation and polymerization of the potential gum is obtained (see Hunn, Fischer, and Blackwood [52, 1930], Littlejohn, Thomas, and Thompson [58, 1930], Bridgeman and Aldrich [14, 1931]).

A sub-committee of the American Society for Testing Materials [86, 1932] has described two air-jet methods, low temperature (100° C), and high temperature (190° C), for

further investigation. A modification of the high-temperature method (at 155° C) has now been introduced as a standard under A S T M Designation D 381-34 τ 50 ml. of gasoline, contained in a 100-ml Berzelius type glass beaker, is evaporated off at a temperature of 155° C under an air jet of 1 litre per sec. Upon completion of evaporation (8-14 min) the beaker is left in place for a further 15 min and, after cooling, the residue is weighed.

The Institution of Petroleum Technologists has recently introduced a standard method (tentative) for preformed gum, based on the A S T M low-temperature method, which is stated to have an accuracy of 10% for duplicate determinations. In this method, under I P T Serial Designation G 25 (r), 25 ml or 50 ml of the gasoline is evaporated in a 6 cm or 9 cm glass dish over a steam bath, a jet of air impinging on the surface of the gasoline, the residue is finally heated at 150° C for 1 hr before weighing (see also *Proc World Petr Cong*, 1933, 2, 94).

In the standard French Method (A F N O R B 6-13) the gasoline samples (100 ml) are evaporated in glass dishes over a steam bath. The bath is covered by a large Bell Glass through apertures in which a continuous stream of air is drawn, so that the evaporation conditions for each sample are identical, the residue of gum is finally heated for 16-20 hr at 160° C.

It should be observed that a rigidly standardized technique in sampling and in manipulation is essential for obtaining satisfactory results in determination of 'actual gum'.

Comparable figures for gum determination by different methods are given in many of the papers quoted (see, particularly, Mulligan, Lovell, and Boyd [69, 1932]), and a considerable amount of work has been carried out on the correlation of these with engine deposits of gum. Such deposits are invariably much lower than the calculated values from any of these methods, a considerable proportion of the gum being carried into the combustion chamber and burnt [53, 1930, 63, 1932]. It appears in general that the maximum gum tolerance in a gasoline is of the order of 10-15 mgm when determined by the more recent air-jet methods (for further information see *Proc World Petr Cong*, 1933, 2, 'Determination of Gum in Gasoline').

Determination of Potential Gum—Gum Stability Tests. With the exception of the copper-dish test, the methods described previously give no indication of the potential gum, i.e. the gum which would be formed during storage of the gasoline. This may be determined by the use of accelerated oxidation tests in which the gasoline is submitted to oxidation under elevated temperature and oxygen pressure, the progress of oxidation being followed either by the oxygen absorption or the formation of actual gum, or both. It is found that the 'induction period' elapsing between commencement of the test and the first rapid absorption of oxygen—the so-called 'break-down' time—can be related to that under normal storage conditions, and is thus some indication of the maximum period of storage possible with negligible gum formation (see Hunn, Fischer, and Blackwood [53, 1930], Ramsay [83, 1932], Ramsay and Davis [84, 1933], Aldrich and Robe [4, 1932], Thomas [95, 1933]).

The procedure adopted by the U S Army and Navy and by the Ethyl Gasoline Corporation has been described by Zublin [106, 1931]. The apparatus resembles that developed by Ramsay [83, 1932], which comprises a stainless-steel bomb, fitted with a pressure recorder. The gaso-

line sample (100 ml) is contained in an 8-oz sample bottle and the test is usually run at a temperature of 212° F with an initial oxygen pressure of 100 lb per sq in. The development of a standard gum-stability test on these lines is under investigation by a sub-committee of the American Society for Testing Materials [87, 1934].

The use of such severe oxidation conditions has been criticized. A method developed at the laboratories of the Anglo-Iranian Oil Company [95, 1933] utilizes an initial oxygen pressure of only 10 lb with determination of the increase in preformed gum. The bomb used is an adaptation of the ordinary Mahler-Cook calorimeter bomb. The procedure tentatively adopted at the British Air Ministry Laboratories [62, 1933] involves incubation of the gasoline at 35° C for 20 hr under atmospheric pressure, with determination of the increase in preformed gum. A similar method has been tentatively standardized under I P T Serial Designation G 25 a (i). 50 ml of the gasoline is maintained at 200° C for 2 hr in a sealed 500 ml flask and the increase in existent gum determined. Work is being carried out on the correlation of this test with the results of storage. In the case of motor benzoles, the gum stability is determined by subjection to a mild ageing test, with passage of oxygen through the spirit under reflux, and estimation of the increase in gum content (Hoffert and Claxton [48, 1928-9, 1933], Haun [44, 1932]).

The correlation of accelerated gum-stability tests with the actual stability of the gasoline in storage is in a very debatable position. The simplest procedure, which has been widely adopted, is to refine the product to the same gum-stability figure as that of a gasoline known to be satisfactory in storage. A considerable amount of further research is necessary, however, to clarify the position [103, 1933, 87, 1934].

Sulphur and Sulphur Compounds

Sulphur may be present in a gasoline in the free state, as hydrogen sulphide, or as organic compounds of varying stability. Free sulphur is extremely corrosive (particularly with copper and its alloys) and should not be present in greater amount than 0.5-1.0 mgm per 100 ml of fuel [47, 1925, 42, 1931]. Hydrogen sulphide is corrosive but, from its pronounced odour, is never present in a refined gasoline, mercaptans, which are extremely corrosive, are usually absent for the same reason. Sulphoxides and polysulphides have some slight corrosive action, but thiophene, carbon-disulphide, and the alkyl sulphides have practically none. (For the action of corrosive sulphur compounds on metals, see Birch and Norris [8, 1929], Hoffert [47, 1925], Schmidt [90, 1927], Wood, Sheeley, and Trusty [104, 1925]).

A gasoline of high non-corrosive sulphur content may yet cause severe crankcase and bearing corrosion under conditions such that condensation and accumulation of water in the crankcase can occur, when corrosive sulphur acids from the combustion of the fuel may be formed. The total sulphur content of a gasoline is for this reason usually kept below 0.1 to 0.15%, although this maximum may be increased considerably under favourable conditions (cf. Diggs [26, 1928]).

Total Sulphur. The detection of sulphur, particularly in heavier products, may be carried out by the well-known sodium fusion test (see Gatterman, *Practical Organic Chemistry*). According to Lane and Devine [55, 1927] the method is sensitive to 0.02% sulphur if detection of the resultant sulphide is effected by lead acetate paper in place of sodium nitro-prusside.

The available methods for the estimation of total sulphur in light distillates involve combustion of the oil and subsequent determination of the sulphur oxides produced, the Carus method being too tedious for normal use. The oxygen bomb method is very little used for gasolines, the apparatus being expensive and the satisfactory combustion of the spirit necessitating careful technique. The most widely used methods are modifications of the sulphur lamp. Essentially a definite amount of the gasoline is burnt in a small lamp and the products of combustion drawn through an alkaline washing tower. The sulphur acids produced may be estimated volumetrically, or gravimetrically as barium sulphate, the volumetric method, from its convenience, is used almost exclusively in routine and plant-control work.

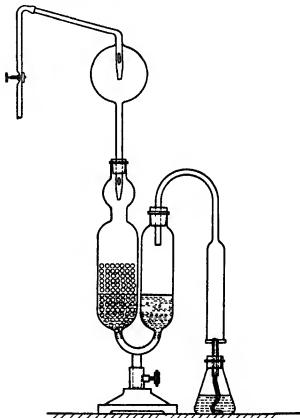

FIG 6 Total sulphur apparatus—A S T M

In the method standardized under A S T M Designation D 90-34 r (Fig 6), which has been adopted (with modification) under I P T Serial Designation G 4 to replace the former gravimetric method, approximately 3 gr of gasoline are burnt and the products of combustion drawn through a U-tube absorber containing sodium carbonate solution (3.306 gm per litre). The residual alkali is titrated with hydrochloric acid and the equivalent sulphur content of the sample calculated.

Several modifications to this apparatus have been devised (see *Analytical Edition of the Journal of Industrial and Engineering Chemistry*). The most widely used of these is that due to Edgar and Calingaert [27, 1930, 1934] which offers several advantages over the original apparatus. The air supply to the lamp is drawn through a purifying tower to avoid the necessity for a blank determination (as incorporated in the Richardson Lamp, *I P T Handbook*,

1929 ed., p. 16). The lamp incorporates a flame-adjustment device and a calibrated-burette reservoir, for volumetric measurement of the spirit burnt, which may be kept cooled in the case of very volatile samples. In addition the efficiency of absorption is improved and the titration facilitated by a sintered glass-absorption bubbler. The sensitivity of the titration end-point is further improved by a composite methyl orange-indigo carmine indicator introduced at the U S Bureau of Mines by Espach and Blade [32, 1931]. The Esling Lamp has also been used to some extent in Great Britain. In Germany and on the Continent modifications of the Engler-Heuser lamp are widely used (Holde [49, 1933], p. 105).

For highly aromatic spirits (e.g. benzoles) dilution of the fuel with alcohol or white spirit of known sulphur content may be necessary to avoid smoking. The standard method for motor benzoles is described under S M T T P Serial No. L.B. 11.

The lamp method is satisfactory for the determination of sulphur in light distillates provided the sulphur content is not very high. There is some tendency, however, for low results to be obtained with mercaptans and particularly with carbon disulphide (see Espach and Blade [32, 1931], Waterman and van Tussenbroek [101, 1927-9]).

The combustion-tube method, involving catalytic oxidation of the vaporized gasoline in a stream of air, has been developed by Grote [43, 1933] and others, and has been adopted in the French standard method under A F N O R B 6-14 (cf. B 6-28). The spirit is vaporized by bubbling air through it and the resultant air-gasoline mixture passed through a heated quartz tube. The sulphur acids formed are estimated by titration.

Free, Corrosive, or Elemental Sulphur.

Detection and Corrosion Tests. Free sulphur is detected and estimated by its corrosive action on metals, the use of copper will also show the presence of mercaptans and hydrogen sulphide.

The copper-strip test is standardized under A S T M Designation D 130-30, and under A F N O R B 6-14 (111 A). A clean copper strip is immersed in the gasoline at 50°C for 3 hrs., any resulting discoloration of the copper indicating corrosive sulphur. The use of a higher temperature renders the test more sensitive to other sulphur compounds [42, 1931]. The well-known copper-dish test (U S Bur Mines Tech Paper 323 B, 1927, p. 96) in which the spirit is heated in a hemispherical copper dish, is preferred by some to the copper-strip test (cf. McVitty [65, 1930]).

The most sensitive method for the detection of elemental sulphur is to shake the gasoline with mercury, formation of a black film or precipitate indicating the presence of free sulphur. The sensitivity of this test has been stated to be of the order of 0.0005% (*I P T Handbook*, 1929, p. 18, see Rue [88, 1928]). According to Kiemstedt [54, 1932] organic peroxides are capable of causing blackening of the mercury in this test.

Estimation. Free sulphur may be estimated by the mercury method (Ormandy and Craven [73, 1923]), formerly adopted under I P T Serial Designation G 46-1929. The black precipitate is filtered off, decomposed in aqua regia, and the sulphur precipitated as barium sulphate. In the standard method for benzoles (S M T T P Serial No. L.B. 12) the sulphide is estimated volumetrically (cf. Kiemstedt [54, 1932]).

The present method, standardized under I P T Serial

Designation G 46, is based on that introduced by Garner and Evans [42, 1931]. 100 ml. of the spirit is refluxed for 1 hr. with 0.5 gr. of 'copper-bronze' powder. The residue is filtered off, washed, dissolved in bromine water, and the sulphur estimated gravimetrically as barium sulphate. The results, corrected for the blank determination, are expressed as milligrams of corrosive sulphur per 100 ml. of sample. A similar method has been adopted in France (A F N O R B 6-14-111 B). A volumetric method based on the 'Doctor' test is given by Wirth and Strong [103a, 1936].

Mercaptans.

Mercaptans (and hydrogen sulphide) are detected by the well-known 'Doctor' test in which the spirit is shaken with sodium plumbite solution, made by dissolving litharge in caustic soda. A small quantity of flowers of sulphur is added and the mixture shaken again. If the sample, or sulphur film, is discoloured it is reported as 'sour', if not, it is reported as 'sweet'. The methods detailed by the Natural Gasoline Association of America and the U S Bureau of Mines (U S Bur Mines Tech Paper 323 B, 1927, p. 96), have been compared by Boyd [12, 1933] who found the sensitivity to be of the order of 0.0002% sulphur as mercaptans. A similar method is standardized under I P T Serial Designation G 33 (For theoretical consideration of the reaction see Wendt and Diggs [102, 1924]).

The estimation of mercaptans is of importance only for research and investigational work, and no standardized procedure has been adopted. Wendt and Diggs [102, 1924] utilize the Doctor reagent, estimating the lead sulphide produced, Borgstrom and Reid [11, 1929] adopt a volumetric method with silver nitrate, while Bond [10, 1933] has recently described a very simple procedure involving direct titration with copper oleate solution (see also papers by Faragher, Morrell, and Monroe [35, 1927], Sampey and Reid [89, 1932], and Schulze and Chaney [91, 1933]).

An interesting method for the general examination of the sulphur compounds in light distillates has been used by Faragher, Morrell, and Monroe [35, 1927], hydrogen sulphide is precipitated with acidified cadmium chloride solution, elementary sulphur is removed by shaking with mercury, mercaptans with alcoholic sodium plumbite, disulphides by reduction to mercaptans (and estimation as such), and sulphides with mercurous nitrate. Any residual sulphur is assumed to be thiophene, the A S T M lamp method being used to determine the sulphur removed in the latter stages.

Carbon disulphide and thiophene may be present in benzole blends. The former is usually estimated with alcoholic potassium hydroxide, and thiophene by use of Deniges reagent (mercuric sulphate), but these reagents are of little utility in the presence of unsaturateds.

Acidity

The presence of free acid in a gasoline is very rarely encountered, and is an obvious indication of inefficient refining. The acidity may be titrated directly with standard alkali in alcoholic solution. Spirit soluble sulphur compounds, produced during acid refining and incompletely removed, may decompose upon heating with formation of acid products, and it is occasionally specified that the residue after distillation shall be neutral, the aqueous

THE LABORATORY TESTING OF PETROLEUM PRODUCTS

extract being titrated with methyl orange (A S T M Designation 235-34 7)

Water

The solubility [2, 1931] of water in light petroleum hydrocarbons is very low (of the order of 0.005%) but is greater in benzene (approximately 0.06%) and may be of a high order in alcohol blends. The presence of suspended or dissolved water in a gasoline may cause trouble by accumulation in and blockage of the fuel-supply system, particularly when low temperatures are encountered, and may lead to tank corrosion. Appreciable water in alcohol blends will proportionately lower the water stability of the fuel.

The estimation of water in gasolines is usually carried out by a chemical method (see, however, Clifford [20, 1921-2, 1929]). Aldrich [2, 1931] has used a very accurate method involving measurement of the hydrogen evolved with sodium-potassium alloy, but this is too tedious and requires a too elaborate technique for general adoption. Dietrich and Conrad [25, 1931] utilize the reaction with magnesium nitride, estimating the ammonia evolved, and find the method applicable to blends of methyl and ethyl alcohol. A more rapid method, claimed to be suitable for routine work, is that of Broche and Scheer [15, 1933] in which the volume of hydrogen liberated by the fuel from magnesium hydride is measured.

Stability of Alcohol Blends

Alcohol blends, under conditions of low temperature, or in the presence of water, may separate into two layers (alcohol and hydrocarbon). Such segregation in storage, or during use, is most undesirable and the behaviour of an alcohol blended fuel towards these two factors is of importance.

The 'cloud point' is determined by cooling a sample of the fuel in a suitable apparatus (the I P T aniline-point apparatus is suitable, I P T Serial Designation F O 23), and observing the temperature at which turbidity first appears.

The water tolerance of the fuel may be determined by the method standardized in France under A F N O R B 6-15. Water is slowly added to 100 ml of the spirit, maintained at 0° C., until a permanent turbidity is produced. The amount of water (in ml.) added is termed the 'Stability at 0° C.' of the fuel.

The method of Ormandy, Pond, and Davies [79, 1934] involves the use of two graduated vessels in which 50 ml and 500 ml respectively, of the fuel are shaken with 2.5 ml of water. From the volume of aqueous alcohol separated in the two cases, the percentage of alcohol present in the blend and the water tolerance in ml per gallon are obtained by the use of tables provided.

Cold Test

The freezing-point of a light petroleum spirit normally lies below -100° C., but the presence of benzene (with a freezing-point of 5.4° C.) may raise this considerably. For aviation gasolines, exposed to low temperatures at high altitudes, some form of cold test is usually specified, unless aromatic hydrocarbons are expressly excluded.

Two methods have been put forward as Tentative Standards under I P T Serial Designation G 11 (r). In the first method, 5 ml of the sample, contained in a test tube fitted with the 'I.P.T. Cold Test' thermometer (toluene

filled) and a stirring device, is cooled by gradual immersion in a suitable refrigerant. If no crystals of solid hydrocarbons are present when the temperature has fallen to -50° C., the cold test is reported as below -50° C. If crystals are present the tube is removed from the cooling bath and allowed to warm up. The temperature at which the last particles disappear is recorded as the cold test of the sample. The alternative method utilizes a more elaborate apparatus, provided with inlet and exit tubes for dry air, and a delivery funnel for introduction of the sample.

In the determination of the cold test it is of importance that the sample should be dry in order to obviate any obscuring of the freezing-point by deposition of ice crystals.

Estimation of Lead Tetraethyl in Gasolines

The presence of lead compounds in a gasoline may be detected by addition of bromine in carbon tetrachloride solution. Any precipitate is filtered off, washed with petroleum ether, dissolved in nitric acid and the solution tested for lead with the usual qualitative tests.

Lead tetraethyl may be decomposed by many reagents and the lead estimated by the normal methods. The procedure developed at the Ethyl Gasoline Corporation laboratories, described by Edgar and Calingaert [28, 1924, 1929], has been adopted, with some modification, as the standard method under I P T Serial Designation G 38. 100 ml of the gasoline is treated with 30% bromine solution in carbon tetrachloride, the precipitate dissolved in nitric acid, and the lead estimated by precipitation as the chromate. A volumetric estimation with ammonium molybdate is also described by the previous authors. For gasolines containing a large proportion of unsaturated compounds, the method due to Baldeschweiler [6, 1932] has been claimed to be more suitable, the lead tetraethyl being decomposed with nitric acid. The use of X-ray absorption and ultra-violet spectroscopy for this estimation have been proposed by Aborn and Brown [1, 1929], and by Clark and Smith [19, 1929].

Chemical Analysis

A considerable amount of work has been carried out on the determination of the constituent classes of hydrocarbons in gasoline and light spirits generally. Primarily this has been in connexion with the evaluation of gasolines from the point of view of their anti-knock value and, in spite of the immense amount of research involved, it cannot be said that the analysis of a gasoline, as at present possible, is any reliable indication of its detonation characteristics. For this purpose the knock-testing engine is of far greater utility and will give all the information required. The analytical methods available for gasoline are of importance, at the present time, for investigational and research purposes only. The present views on the detonation characteristics of hydrocarbons are discussed elsewhere.

Gasolines comprise a very large number of hydrocarbons of different classes, and may, in addition, contain benzole, alcohols, blending agents, anti-knock dopes, and gum inhibitors. The presence of unsaturated hydrocarbons from cracked distillates increases the analytical difficulties to a marked degree.

When alcohols are present, a preliminary separation into water-soluble and insoluble portions is necessary. An approximate value for the alcohol content may be obtained

by the addition of a measured volume of water, in excess of that required to effect separation of the spirit into two layers. The volume of the lower aqueous layer, less the volume of water added, represents the approximate amount of alcohol present. According to Holde's procedure [49, 1933], the spirit is washed with a calcium chloride solution and the aqueous layer examined for alcohols by fractional distillation. When ethyl, or methyl, alcohol alone is known to be present, determination of the refractive index or the density of the distillate forms a convenient means of estimation (Mortimer and Giese [68, 1933]).

The water-insoluble portion is examined for hydrocarbons. With the occasional exception of benzene and its homologues, no attempt is made to determine individual hydrocarbons, but merely to estimate the relative proportions of the different hydrocarbon classes usually present, these are in decreasing order of reactivity: olefines (unsaturateds), aromatics, naphthenes, and paraffins. Cracked spirits possess a high proportion of unsaturateds. The general procedure is to estimate these hydrocarbons in the order of their reactivity, since this varies widely for individual members of a given series, and since in addition a hydrocarbon may combine in itself the characteristics of more than one of these classes, the analytical methods are of limited accuracy and the results of value chiefly for comparison purposes only.

For comprehensive accounts of the methods available, reference should be made to papers by Howes and others [50, 1930, 71, 1935, 34, 1930].

Olefines (Unsaturateds)

Absorption in Sulphuric Acid The determination of unsaturateds by absorption in sulphuric acid has been widely used, a common procedure being to shake the spirit with twice its volume of acid, allow to separate, and then assume the diminution in spirit volume to equal the content of unsaturateds (Dean and Hill [24, 1927]). The strength of acid is extremely important, absorption being incomplete below 80%, aromatics being attacked above 85%, and saturated hydrocarbons above 100% acid strength. To remove high-boiling spirit-soluble polymers it is necessary to distil the treated spirit to its original end-point before calculating loss to acid (Faragher, Morrell, and Levine [34, 1930], Egloff and Morrell [30, 1926], Ormandy and Craven [76, 1925], Lomax and Pemberton [59, 1926]).

In general, the estimation of unsaturateds with sulphuric acid is, in the presence of aromatics, of comparative value only, but in their absence is capable of yielding results of fair accuracy.

Iodine and Bromine Values. Unsaturated compounds react with halogens, adding on two atoms of halogen for every double bond. The reaction is complicated by incomplete addition in certain compounds, and by substitution reactions. The latter are particularly noticeable in the higher boiling hydrocarbons. The iodine or bromine value is the number of grams of halogen absorbed by 100 g. of the oil and indicates the 'percentage of double bonds' in the material. The content of olefines can then be calculated if their type and molecular weight are known. No serious error is usually introduced if they are assumed to be mono-olefines, while their molecular weight may be estimated from the mid-point of the distillation curve of the spirit.

The methods of Hubl and Wigs, used for fatty oils, are found of little value for hydrocarbons. The Hanus iodine

value, in which the spirit is treated with an excess of a solution of iodine and bromine in acetic acid, and the residual halogen estimated with thiosulphate, has been widely used for gasolines (Dean and Hill [24, 1927], Faragher, Gruse, and Garner [33, 1921], Egloff and Morrell [29, 1925]).

In the McIlhenny bromine method [64, 1899] the addition and substitution values are separately determined. The oil is allowed to react with a solution of bromine in carbon tetrachloride (0.1-0.3 N), the excess being determined by addition of potassium iodide and titration with sodium thiosulphate. The hydrogen bromide, liberated in the substitution reaction, is subsequently determined by addition of potassium iodate and titration of the liberated iodine, and the addition and substitution bromine values thence calculated. This method (I.P.T. Serial Designation G 39 (r)) is probably the most satisfactory available. The Francis method [39, 1926], in which the bromine is produced by acidification of a potassium bromide-bromate solution, has also been used for light distillates. Determination of the bromine, or iodine, value may be regarded, in general, as the most successful method available for the evaluation of the unsaturated content of cracked gasolines.

Sulphur monochloride treatment for the removal of olefines has been used successfully by Faragher, Morrell, and Levine [34, 1930], the unchanged spirit being vacuum distilled from the sulphides formed. Other methods which have been used for the estimation of unsaturateds are detailed in the papers referred to [50, 1930, 71, 1935].

Aromatic Hydrocarbons

Sulphonation Aromatic hydrocarbons may be removed by sulphonation with sulphuric acid, 98% concentration being normally used (Ormandy and Craven [77, 1926], Faragher, Morrell, and Levine [34, 1930]). The spirit is shaken for about 15 min. with 2 to 3 vols. of the acid, this treatment being repeated if necessary to secure complete sulphonation. The amount of aromatics removed may be estimated from the volume of spirit absorbed (unsatisfactory on account of solubility effects), by determination of the sulphonic acids as their barium salts [77, 1926, 99, 1931], or by measurement of the change in some physical property of the spirit. Specific gravity [94, 1919, 96, 1929] and refractive index [90, 1927, 51, 1925] have been used, but the most general method is to determine the elevation of the Aniline Point of the spirit (Tizard and Marshall [97, 1921])—the temperature of miscibility of equal volumes of spirit and aniline. This elevation is proportional to the amount of aromatic hydrocarbons removed, but varies with the character both of the residual spirit and the aromatics [96, 1929]. For concentrations of less than 20% aromatics, the following equation yields approximate results

$$A = \alpha (T - T_1)$$

where A = percentage aromatic hydrocarbons by weight,
 α = 1.19 for benzene,
 1.20 for toluene,
 1.23 for xylenes,
 T = aniline-point after removal of aromatics,
 T_1 = aniline-point before removal of aromatics.

In the determination of the aniline-point, described under I.P.T. Serial Designation F O 23, it is of particular importance that the aniline used be freshly distilled and free from water.

Nitration The ready nitration undergone by aromatic hydrocarbons lends itself to their estimation. Hess [45 1920 1926] carries out the nitration in a vessel with a narrow graduated neck sufficient sulphuric acid is then added to dissolve the nitro compounds and to allow the volume of unchanged oil to be read on the graduated portion of the vessel. Egloff and Morrell [30 1926 34 1930] use relatively dilute nitrating acids and measure the volume of the resultant nitro compounds which separate as a distinct layer. The aromatic content is then calculated by a conversion factor.

Olefines and Aromatics present together

The satisfactory analysis of a spirit containing both aromatics and unsaturated in addition to paraffins and naphthenes presents some difficulty. The classical method involving successive removal of unsaturated and aromatics with differing strengths of sulphuric acid has been modified by Riesenfeld and Bandte [85 1925 7] Morrell and Levine [67 1932] and Towne [99 1931] among others.

Egloff and Morrell [30 1926] remove unsaturated with 80% sulphuric acid and determine the aromatics by nitration (loc cit). Faragher, Morrell and Levine [34 1930] estimate the unsaturated and aromatics together by treatment with 91% sulphuric acid distillation to remove polymers and final treatment with 98% acid. The aromatics alone are separately determined by nitration after removal of the olefines by treatment with sulphur monochloride and distillation of the olefine free oil. In

the procedure developed by Garner [41 1928] the unsaturated and aromatics are removed together by treatment with fuming nitric acid and their amount calculated from the change in aniline point before and after this treatment. The olefines are then separately estimated from the Hanus iodine value of the original spirit (cf Manning [60 1929 61 1930]). A simplified version of this method has been tentatively adopted under I.P.T. Serial Designation G 39 (r) (*I.P.T. Handbook* pp 215 18).

Paraffins and Naphthenes

The estimation of paraffins and naphthenes carried out on the aromatic and olefine free spirit is the least satisfactory step in the analysis. Their relative stabilities are so variable that chemical methods give place to physical determinations. The usual procedure is to determine the aniline point of the residual spirit, the approximate naphthene content being given by the formula [97 1921 74 1924]

$$\text{per cent naphthenes} = 70 - \frac{\text{aniline point } ^\circ\text{C}}{0.3}$$

More reliable results are obtained if the spirit is in addition classified by its 50% distillation temperature (mid point). The per cent of naphthenes may then be estimated from the chart introduced by Garner [41 1928]. The specific gravity [66 1933 74 1924] and the refractive index [74 1924] have also been used in place of the aniline point for the determination of the naphthene content.

REFERENCES

- 1 ABORN R H and BROWN R H *Ind Eng Chem Anal Ed* 1 76 (1929)
- 2 ALDRICH F W *Ind Eng Chem Anal Ed* 3 348 (1931)
- 3 ALDRICH E W BRIDGEMAN and WHITE *J S A E* 24 488 (1929)
- 4 ALDRICH E W and ROBIN N P *J S A E* 30 198 (1932)
- 5 AULD S J M *J I P T* 15 645 (1929)
- 6 BALDESCHWILER E L *Ind Eng Chem Anal Ed* 4 101 (1932)
- 7 BEBWEGER G A and CHILDS W C *Ind Eng Chem Anal Ed* 2 284 (1930)
- 8 BIRCH S F and N ARN W S *Ind Eng Chem* 21 1087 (1929)
- 9 BLAIR M C and ALDEN R C *Ind Eng Chem* 25 559 (1931)
- 10 B N D G R *Ind Eng Chem Anal Ed* 5 257 (1933)
- 11 B RIGSTROM P and REID E E *Ind Eng Chem Anal Ed* 1 186 (19 9)
- 12 BOYD G A *Oil and Gas J* 32 (8) 16 (1933)
- 13 BRIDGEMAN O C *J S A E* 22 437 (1928) see later publications in this journal
- 14 BRIDGEMAN O C and ALDRICH E W *J S A E* 28 191 (1931)
- 15 BROCHER H and SCHEER W *Brenn Chem* 13 281 (1937) 14 408 (1933)
- 16 BROWN G G *Engineer & Reear* 1 B II no 14 May 1930 University of Michigan
- 17 ——— Natural Gasoline Assoc of America *Proc 10th Ann Conv* May 1931 p 75
- 18 CALMAN W H *J I P T* 10 947 (1924)
- 19 CLARK G L and SMITH H A *J Phys Chem* 33 659 (1929)
- 20 CLIFFORD C W *Ind Eng Chem* 13 628 (1921) see U S A r Services Informant on Circular 1922 320 USPENSKIKH *Nefi Kho* 17 713 (1929)
- 21 COOKE M B U S Bur Mines Repts Invest no 2686 May 1925
- 22 CROSS R *Handbook of Petroleum Asphalt and Natural Gas* (1931)
- 23 DAY D *Handbook of the Petroleum Industry* 1 (1922)
- 24 DEAN E W and HILL H H U S Bur Mines Tech Paper no 181 (1927)
- 25 DIETRICH K R and CONRAD C *Z angew Chem* 44 532 (1931) of KREMER M *Patr Z* 27 443 (1931)
- 26 DIGGS S H *Ind Eng Chem* 20 16 (1928)
- 27 EDGAR G and CALINGAERT G *Ind Eng Chem Anal Ed* 2 104 (1930) see L LAY R M *Refiner* 13 177 (1934) see also Espach R H and BLADE O C loc cit
- 8 EDGAR G and CALINGAERT C *Ind Eng Chem Anal Ed* 1 1 (1929) of OMBANDY W R *J I P T* 10 954 (1924)
- 29 ETCOFF C and MARRELL J L *Ind Eng Chem* 17 1259 (1925)
- 30 ——— *I. I. Eng. Ch. M* 18 354 (1926)
- 31 EILING F *J I P T* 7 85 (1919) 20 1051 (1934)
- 32 ESPACH R H and BLADE O C U S Bur Mines Tech Paper no 513 (1931)
- 33 FARAGHER W F GRUBE W A and CARNER F H *Ind Eng Chem* 13 1044 (1921)
- 34 FARAGHER W F MORRELL J C and LEVIN I M *Ind Eng Chem Anal Ed* 2 18 (1930)
- 35 FARAGHER W F MORRELL J C and MONROE G S *Ind Eng Chem* 19 1281 (1927)
- 36 FULTON W L *Oil and Gas J* 30 (46) 28 (1932) 33 (45) 90 (1935)
- 37 FENSKO M R Q O LF D and TONBERG C O *Ind Eng Chem* 24 408 542 (1932)
- 38 FENSKO M R T NEIBERG C O and QUIGGLE D *Ind Eng Chem* 26 1169 1213 (1934) ROSE A Jb d 28 1210 (1936)
- 40 GARD C D *Oil and Gas J* 26 (29) 138 (1928) of Report Vap Press Committee Calif Natl Gas Assoc *Oil and Gas J* 27 (32) 186 (1929)
- 41 GARNER F H *J I P T* 14 695 (1928)
- 42 GARNER F H and EVANS E B *J I P T* 17 451 (1931)
- 43 GROTE W and KREPKLER H *Z angew Chem* 46 106 (1933)
- 44 HAIM C *Brenn Chem* 13 (7) 128 (1932)
- 45 HIRM W *Z angew Chem* 33 147 176 (1920) *Erdöl u Teer* 2 779 (1926)
- 46 HILL J B and FERRIS S W *Ind Eng Chem* 19 379 (1927)
- 47 HOFFERT W H and others *2nd Report of Nat Ben ole Assoc* March 1923
- 48 HOFFERT W H and CLAYTON G *Report Jo nt Ben ole Res Comm* 1928 p 57 1929 p 82 of *Motors Benzole* 578 (1933)
- 49 HOLDE D *Kohlenwasserstofföle u Fette* 1933 7th ed
- 50 HOWES D A *J I P T* 16 54 (1930)
- 51 HOYTT W N *J I P T* 11 76 (1925)
- 52 HUNN E B FICHER H G M and BLACKWOOD A J *Proc A P I* 11 (3) 124 (1930)

- 53 HUNN, E. B., FISCHER, H. G. M., and BLACKWOOD, A. J. *J. S. A. E.* 26, 31 (1930)
- 54 KIMMSTEDT, H. *Brenn-Chem* 13, 310 (1932)
- 55 LANE, F. W., and DEVINE, J. M. *U. S. Bur. Mines Repts Invest* no. 2828 (1927)
- 56 LIEBE, E. H. *Motor Fuels* (1923)
- 57 LEWIS, W. R., and COLFMAN, S. P. *Oil and Gas J* 29 (42), 130 (1931)
- 58 LITTLEJOHN, W., THOMAS, W. H., and THOMPSON, H. B. *J. I. P. T.* 16, 684 (1930)
- 59 LOMAX, E. L., and PEMBERTON, E. S. *J. I. P. T.* 12, 55 (1926)
- 60 MANNING, A. B. *J. C. S.* 1014 (1926)
- 61 MANNING, A. B., and SHEPHERD, F. M. E. *DSIR Research Paper* no. 28 (1930)
- 62 MARDIFF, E. W. J., and MOSS, I. *Proc. World Petr. Cong.* 2, 116 (1933)
- 63 MARLEY, S. P., and GRUSE, W. A. *Ind. Eng. Chem.* 24, 1298 (1932)
- 64 McILHINNEY, P. C. *J. A. C. S.* 21, 1084 (1899)
- 65 McVITT, E. W. *J. S. A. E.* 27, 684 (1930)
- 66 MENTER, C. C. *Nat. Petr. News*, 25 (8), 25 (1933)
- 66a MORRELL, J. C., BRINDECK, W. L., and ELOTT, G. *Ind. Eng. Chem.* 28, 122 (1936), cf. BURGLER, C. W., *Refiner*, 15, 411 (1936)
- 67 MORRELL, J. C., and LFWINE, I. M. *Ind. Eng. Chem., Anal. Ed.* 4, 321 (1932)
- 68 MORTIMER, F. S., and GIESE, E. H. *Ind. Eng. Chem., Anal. Ed.* 3, 356 (1931)
- 69 MULLIGAN, M. J., LOVELL, W. G., and BOYD, T. A. *Ind. Eng. Chem., Anal. Ed.* 4, 351 (1932)
- 70 MURPHY, G. B., and WIRTH, C. *Oil and Gas J* 31 (44), 24 (1933)
- 71 NASH, A. W., and HOWES, D. A. *Principles of Motor Fuel Preparation and Application*, 2 (1935)
- 72 OERFFEL, G. G., and ALDEN, R. C. *Oil and Gas J* 31 (35), 14 (1933), *Scheumann, Refiner*, 15, 239 (1936)
- 73 ORMANDY, W. R., and CRAVEN, E. C. *J. I. P. T.* 9, 133 (1923)
- 74 ———— *J. I. P. T.* 10, 101 (1924)
- 75 ———— *J. I. P. T.* 10, 342 (1924)
- 76 ———— *J. I. P. T.* 11, 533 (1925), cf. HOUGHTON and BOWMAN, *ibid.* 11, 583 (1925)
- 77 ———— *J. I. P. T.* 12, 68 (1926)
- 78 ———— *J. I. P. T.* 13, 311 (1927)
- 79 ORMANDY, W. R., FOND, T. W. M., and DAVIS, W. R. *J. I. P. T.* 20, 914 (1934), cf. BAYLEY and HOPKINS, *Canad. J. Res.* 11, 505 (1934)
- 80 OSTWALD, W. A. *Z. angew. Chem.* 39, 98 (1926), cf. KROCK, E. *Petr. Z.* 22, 1245 (1926)
- 81 PETERS, W. A., and BAKER, T. *Ind. Eng. Chem.* 18, 69 (1926)
- 82 PODBIELNIAK, W. *J. Ind. Eng. Chem., Anal. Ed.* 3, 177 (1931), 5, 119, 172 (1933)
- 83 RAMSAY, J. W. *Ind. Eng. Chem.* 24, 539 (1932)
- 84 RAMSAY, J. W., and DAVIS, H. S. *Ind. Eng. Chem.* 25, 934 (1933)
- 85 REISENFELD, E., and BANDT, G. *Erdöl u. Teer*, 2, 491, 587, 715 (1926), 3, 139 (1927), *Kattwinkel, Chem. Ztg.* 49, 57 (1925), *Brenn-Chem.* 8, 353 (1927)
- 86 ROOFER, T. H. *Proc. A. S. T. M.* 32 (1), 407 (1932)
- 87 ———— *Proc. A. S. T. M.* 34 (1), 435 (1934)
- 88 RUEL, H. P. *U. S. Bur. Mines Repts Invest* no. 2862 (March 1928)
- 89 SAMPTV, J. R., and RPID, E. E. *J. A. C. S.* 54, 3404 (1932)
- 90 SCHMIDT, H. *Petr. Z.* 23, 646 (1927)
- 91 SKUHLE, W. A., and CHANEY, L. V. *Nat. Petr. News*, 25 (34), 37 (1933)
- 92 SMITH, N. A. C., and COOKE, M. B. *U. S. Bur. Mines Repts Invest* no. 2394 (Sept. 1922)
- 93 STORY, L. G., PROVINI, R. W., and BENNETT, H. T. *Ind. Eng. Chem.* 21, 1079 (1929)
- 94 THOLF, F. B. *J. S. C. I.* 38, 39 (1919)
- 95 THOMAS, W. H. *Proc. World Petr. Cong.* 2, 122 (1933)
- 96 TILISH YEW, M. D., and DUMSKAYA, A. I. *J. I. P. T.* 15, 465 (1929)
- 97 TIZARD, H. T., and MARSHALL, A. G. *J. S. C. I.* 40, 20 T (1921), cf. CHALVANNÉ, G., and SIMON, L.-T., *Compt. rend.* 168, 1111, 1324, 169, 70, &c
- 98 ———— *J. I. P. T.* 8, 217 (1922)
- 99 TOWNE, C. C. *J. I. P. T.* 17, 134 (1931)
- 99a TRUMBULL, H. M., and RICHARDSON, J. O. *Refiner*, 14, 562 (1930)
- 100 WAGNER, C. R., and HYMAN, J. *Oil and Gas J* 28 (25), 124 (1929)
- 101 WATERMAN, H. I., and VAN TUSSENAROCK, M. J. *Erdöl u. Teer*, 3, 743 (1927), *Brenn-Chem.* 9, 37 (1928), cf. FISCHER and HESS, *Erdöl u. Teer*, 5, 83 (1929)
- 102 WENDT, G. L., and DUGGS, S. H. *Ind. Eng. Chem.* 16, 1113 (1924)
- 103 WINNING, C., and THOMAS, R. M. *Ind. Eng. Chem.* 25, 511 (1933)
- 103a WIRTH, C., and STRONG, J. R. *Ind. Eng. Chem., Anal. Ed.* 8, 344 (1936)
- 104 WOOD, A. E., SUFFELY, C., and TRUSTY, A. W. *Ind. Eng. Chem.* 17, 798 (1925)
- 105 YOUNG, S. *Principles of Distillation* (1922)
- 106 ZURLIN, E. W. *Oil and Gas J* 30 (9), 26 (1931)

WHITE SPIRIT

White Spirit—known also as Paint Thinner, and Turpentine Substitute—comprises a light petroleum spirit of characteristics between a gasoline and kerosene, used as a solvent in the paint and varnish industry, and in the dry cleaning of fabrics.

Specifications usually call for a narrow boiling-range between 140° and 220° C., with freedom from heavy ends and oily material. Absence of gum-forming constituents and corrosive sulphur is essential, while good colour and odour are of importance, flash-point must of course conform to existing regulations. English practice is exemplified in the recently issued British Standard Specification, B S S 245—1936, while American practice in the testing of paint thinners is discussed in detail in *The Physical and Chemical Examination of Paints, Varnishes, Lacquers and Colours*, H. A. Gardner, 6th ed., Oct. 1933.

Distillation is carried out in the standard apparatus specified for gasoline. A typical specification calls for less than 5% distillate below 130° C., with not less than 97% below 230° C. The corresponding limits in B S S 245—1936 are 10% below 150° C. and 80% below 190° C.

An evaporation test may also be specified, in which the rate of free evaporation (determined by loss in weight)

under specified conditions is compared with that of an agreed reference sample.

Flash-point (closed) is determined in the Abel or Tag testers described under Kerosene. Due to a narrow distillation range the flash-point of a white spirit may be as high as that of a kerosene of considerably higher mean boiling-point.

Non-volatile Matter, including Gummy constituents, may be determined by evaporation of 50 ml. of the spirit in a glass dish over a steam bath, the residue being weighed and expressed as a percentage (I. P. T. Serial Designation W S 42).

The Spot Test is still included in some specifications although described by the American Society for Testing Materials as a very unsatisfactory and unscientific substitution for a properly interpreted distillation test. A drop of the spirit is allowed to fall on a piece of filter paper which is then exposed to the air for a specified time and examined for any greasy residue or mark (cf. B S S 245—1936).

Reactive Sulphur. Since the spirit is widely used in the presence of lead pigments, the absence of reactive sulphur is imperative.

The White Lead test is commonly used. 25 gm of white

lead and 50 ml of the spirit are heated in a porcelain dish over a water bath for 2 hours, the absence of any darkening indicates that reactive sulphur is not present (I P T Serial Designation W 5 4) (If no change of colour is observed after 18 hours, it is occasionally specified that the test is to be repeated with moist white lead.)

The copper-strip test, used for gasoline, is preferred by some users, while others specify the introduction of the copper strip into the flask during the distillation test (as in B S S 245—1936)

Acidity. The spirit should be free from any trace of acidity, as determined by the reaction to methyl orange. The A S T M Specifications calls for the distillation residue to be neutral towards methyl orange.

The Colour is determined on the Saybolt or Lovibond instruments and is usually specified as Water White.

Specific Gravity is determined by the usual methods. It has little significance in specifications except that, for spirits of similar volatility, a high specific gravity indicates a

higher proportion of cyclic constituents of greater solvent power.

Solvent Power is chiefly dependent on the content of cyclic compounds, particularly aromatics. If necessary, these may be determined by the Aniline-point method (p 1430), but a practical test of the solvent power is generally preferred. The Kauri-Butanol test is widely used in the U S A. 20 gm of a standard solution of Kauri gum in butyl alcohol (100/500) is titrated at 77° F with the spirit under examination until a slight turbidity appears. The number of millilitres of spirit used indicates the solvent power. To avoid discrepancies arising from non-uniformity of the gum solution, the values are generally expressed with reference to pure benzene or turpentine. Baldeschwieler, Traeller, and Morgan (*Ind Eng Chem, Anal Ed* 7, 374 (1935)) prefer to standardize the Kauri-Butanol solution against benzene and *n*-heptane.

For other solubility and stability tests used in the paint and varnish industry, see Gardner (loc cit.)

KEROSENE

Commercially produced kerosines, which formerly comprised only that intermediate fraction of petroleum suitable for use in wick-fed lamps, now include three distinct products a comparatively volatile fraction, known as Power Vaporizing Oil, Power Kerosine, or Tractor Oil, used as fuel in certain spark-ignition engines, normal kerosine used as an illuminant in wick-fed lamps and for oil-vaporizing burners, and finally a heavy well-refined fraction which includes the Long Time Burning Oils and Mineral Seal Oil used in Railway signal lamps and for other purposes where a very steady and long burning flame is essential. The procedure for testing kerosines varies, therefore, in accordance with the use to which they are applied.

A power kerosine should have a high overall volatility (consistent with relevant Petroleum regulations) and reasonably high octane number (of the order of 50-60). This latter requirement necessitates the presence of a fair proportion of aromatic hydrocarbons, undesirable in illuminating kerosines. Absence of corrosive sulphur and gumming constituents, with low-total sulphur, are further desirable characteristics.

The essential feature of an illuminating kerosine is that it shall burn satisfactorily in the type of lamp normally available and used. The burning tests at present in use are not sufficiently comprehensive in themselves to evaluate a kerosine satisfactorily on this basis and must be supplemented by further laboratory testing methods. The necessary information on the chemical composition of the spirit (i.e. its suitability for illuminating purposes) is adequately supplied by the 'Smoke-point' test, while the degree of refining may be satisfactorily judged from the incrustation ('char') formed on the wick during the 24-hour burning test, in conjunction with the determination of the sulphur content. It is also desirable to determine the viscosity of the oil, while the flash-point determination is essential to exclude a spirit of dangerously high volatility. This latter contingency is, however, very rarely met with. Such kerosines are suitable also for use in oil-vaporizing lamps and in hot-bulb internal combustion engines. Long Time Burning Oils and similar products are in addition required

to pass a long time burning test in the type of lamp used in practice.

In addition to these evaluatory testing methods, the determination of the specific gravity, distillation range, and flash-point may be necessary in order to comply with Government, Federal, or Customs regulations, while such qualities as colour, colour stability, and odour, constitute marketing considerations of some importance to the refiner (See Jackson [11, 1933], Moerbeek [14, 1933], Stansfield and Stark [17, 1933]).

Distillation.

The distillation of kerosine is carried out in the standardized modification of the Engler apparatus, described in the Gasoline section under I P T Serial Designation G 3, and A S T M Designation D 86-30. The distillation test is of little significance for illuminating oils beyond indicating their correct classification as kerosines. The presence of heavy ends is undesirable, leading to greater tendency to smoke, and, in general, the closer the boiling-range the better. A dark-coloured distillation residue is considered to be an indication of the presence of wick-encrusting constituents (Moerbeek [14, 1933]).

For Power Kerosines it is desirable to retain as much of the volatile constituents as is consistent with flash-point and other regulations, and to keep the average boiling-point and heavy ends as low as possible. Thus a typical power kerosine will show 40% distillate at 185° C and 85-90% at 240° compared with corresponding figures of 10-20% and 70-90% for an illuminating kerosine.

Viscosity.

The viscosity of kerosine is conveniently determined by the use of a capillary type viscometer as described on p 1411. The Saybolt Thermo-Viscometer has been used in the U S A for this purpose, although not officially standardized. Essentially the liquid is forced down a capillary tube, immersed in the liquid, and the time of ascent of the liquid meniscus, on release of the pressure, is observed (Fortsch and Wilson [6, 1925]).

The viscosity of a kerosine is of importance in that it

determines the flow of oil through the lamp wick, the mathematical treatment of this capillary flow has been dealt with in detail by Stepanoff [18, 1906] Generally speaking, the viscosity should not exceed 2 centipoises at the normal temperature at which the lamp is used

Sulphur.

The total sulphur content of a kerosine is determined by the lamp methods used for gasoline (p 1395) The presence of sulphur in amounts over 0.2% is most undesirable in illuminating oils, causing an unpleasant odour during burning and also contributing to the formation of a 'bloom' on the lamp chimney (For discussion of the causes of 'bloom' see Kewley and Jackson [12, 1927], and Waterman [20, 1925]) In Power Vaporizing Oils, high sulphur content is undesirable from the possibility of corrosion in the crank-case and bearings

Corrosive sulphur is detected by the usual corrosion tests described for gasoline (p 1396) It is equally undesirable in any kerosine from its pronounced corrosive action on metallic components

Colour.

The colour of a kerosine is determined by use of a colorimeter as described for gasoline (see p 1393) The colour is of no practical significance, giving no reliable indication of the degree of refining or general suitability as an illuminant, but, as with gasoline, it still remains an important marketing consideration to the refiner

It is found that certain kerosines, refined to a good colour, tend to go off badly during long storage and transport The colour stability of a kerosine is of considerable importance to the refiner, and accelerated laboratory tests for its evaluation have been evolved The question is dealt with in papers to the World Petroleum Congress, 1933, to which reference should be made for details In the Hillman test [9, 1933], the kerosine is oxidized with lead peroxide in sodium hydroxide solution, while in the Shell laboratories [16, 1933], an alkaline solution of potassium ferricyanide has been used After this accelerated oxidation the kerosine is filtered off and its colour re-determined

Flash-point.

The flash-point of a liquid is that temperature at which an inflammable vapour is first produced in sufficient quantity to yield an explosive mixture with air, when the liquid is heated in a specified form of flash-point apparatus It is thus related to the vapour pressure of the liquid and to the lower limit of inflammability of its vapour, but as ordinarily determined it is an empirical factor, dependent largely on the design of apparatus used The theoretical aspect of flash-point determination has been fully discussed by Ormandy and Craven [15, 1922-3]

In the case of kerosine and similar petroleum products, the hazard of fire or explosion in storage, transport, or in use, has led to the fixing of legal standards for the flash-points of such products It should be borne in mind, however, that fire hazard is in general due more to lack of recognition of the characteristics of the product dealt with than to the actual inflammability

For the determination of the flash-point of light petroleum products, the Abel apparatus is used in Great Britain, the Abel-Pensky in Germany, and the Tag-closed tester in

the U S A, although the Elliott and other testers are still used in certain American States

The Abel Flash-point apparatus (Fig 7) is specified under I P T Serial Designation K 7, for all petroleum products flashing below 120° F, above this temperature the Pensky Martens apparatus is used (see Lubricating Oils, p 1415)

Essentially, the Abel comprises a brass oil-cup of about 75 ml capacity, supported in an air jacket and surrounded by a water bath The oil-cup cover is provided with a thermometer and sliding shutter, operation of which uncovers three orifices in the cover and lowers a test flame into the centre one The oil is heated at the rate of 2° F per minute and the test flame applied for one second every degree until a bluish flash in the interior of the cup is observed, the temperature being recorded as the Flash-point (Abel)

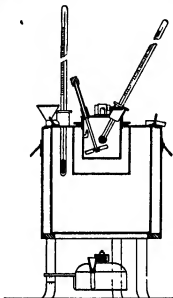

FIG 7 Abel flash-point apparatus

The Abel-Pensky instrument differs from the Abel in that the shutter mechanism is operated by clock-work (thus eliminating the personal factor) The design of the apparatus and its use are standardized by the German Physikalisch-Technische Reichsanstalt (For comparison of the Abel and Abel-Pensky, see Harker and Higgs, *Collected Researches*, National Physical Laboratory, 1912, 8, 38)

The Tag-closed tester is specified under A S T M Designation D 56-36 for all petroleum products, except fuel oil, flashing below 175° F, fuel oil and products of higher flash-point than 175° F are tested in the Pensky Martens instrument The Tag-closed tester resembles the Abel in general design but with the shutter operated by a rack and pinion The oil (50 ml) is heated at the rate of 1.8° F per minute, and, when approaching the flash-point, the test flame is applied for one second every degree rise in temperature The Elliott tester is described in Day's *Handbook of the Petroleum Industry*, 1, 633, and in the *Tag Manual*

In all flash-point determinations it is essential, from the arbitrary nature of the test, that the standardized procedure is rigidly adhered to, particularly in regard to the application of the test flame The flash-point is very sensitive to traces of volatile inflammable liquids and dissolved gases, which cause an abnormal lowering of the flash temperature,

and also to the presence of water which leads to completely unreliable results. It is necessary, therefore, to avoid such contamination of the spirit.

The flash-point of viscous liquids containing volatile hydrocarbons may be determined in the Abel by use of a detachable stirring device (a modification of the Pensky Martens tester suitable for viscous liquids and suspensions has been described, see A S T M Designation D 93-36), while in the case of solids, these may be cut into cylinders and packed in the oil-cup, the determination being carried out in the usual manner.

The Barometric Pressure should be observed during a flash-point determination, and a correction applied to the flash-point temperature if necessary.

As previously indicated, conversion of flash-point readings from one instrument to another is not possible, the following table, however, given by Day (*Handbook of the Petroleum Industry*, 1, 624) shows comparative figures for different instruments.

Comparison of Flash-tests by different instruments in ° F

Material	Abel	Tag	Elliott	Pensky Martens	Cleve- land	Luchare	Fire
Naphtha	86	92	92	95	100	100	110
"	94	103	98	105	115	122	130
Kerosene	127	130	128	135	140	138	160
Petrolite	142	139	140	150	155	144	175
Gas oil				195	200	198	220
300 oil				255	265	266	305
Straw oil				315	325	322	395
Ice-							
machine							
oil				400	385	402	460
Engine oil				430	440	430	515
Cylinder							
oil				505	525	507	610
Heavy oil				510	560	510	635

(For the history and description of early types of flash-point instruments, see Redwood, *Treatise on Petroleum*, 3, section ix.)

Burning Tests.

A satisfactory kerosene for illuminating purposes is required to give a good initial illuminating power in the type of lamp for which the kerosene will normally be used, and to maintain this during the consumption of the oil. It should, in addition, produce no appreciable bloom on the lamp chimney, nor cause any unpleasant odour while burning. While a comprehensive burning test would be expected to give the necessary information, it has in practice been found that the selection of a suitable burning test adequately to evaluate different kerosenes for the widely different lamps in use, and for the widely differing conditions under which they may be used, is a matter of very considerable difficulty. At the present time it cannot be said that any such single test is available, and it appears desirable to make use of two distinct burning tests in addition to other physical testing methods for the satisfactory evaluation of illuminating oils.

The 24-hour burning test for kerosenes, described under A S T M Designation D 187-36, has been widely used. The oil is burnt for 24 hours in a standard Saybolt lamp, refilling every 8 hours. The initial flame size having been adjusted by use of a 'Rather' flame gauge, the final size of flame, condition of wick, and oil consumption are observed at the end of the test. The 8-hour refills necessitate shift work, and the method has been modified in some laboratories by the introduction of a constant-level device (cf Jackson [11, 1933], Downer [4, 1931]). In the tentative

method (Burning Test for Kerosene) recently introduced under I P T Serial Designation K 35 (r), the test is run for 24 hours without refilling in a lamp of standardized design. At the completion of the test, in addition to observation of the oil consumption and condition of the lamp glass, it is specified that the char attached to the wick shall be removed and its weight determined.

The encrustation or char produced on the wick during burning, while dependent to some extent on the chemical nature of the kerosene, is due chiefly to the presence of impurities, including unsaturated compounds, sulphur compounds, heavy ends, and refinery by-products. The amount of char is thus some guide to the degree of refining of the oil, and its determination was suggested by Jackson [11, 1933], as suitable for inclusion in the A S T M 24-hour burning test. The amount of char may be expressed as the number of milligrams of dry char per litre of kerosene burned, and varies from about 2 or 3 mg for a first quality oil up to as high as 100 for very inferior grades.

The 'bloom' produced on the lamp glass during the burning test appears to be related to the sulphur content of the oil, its actual evaluation may be carried out by a photometric method, such as that described at the Summer Conference of the Institution of Petroleum Technologists in 1932. In this method, developed at the Anglo-Iranian Oil Company's laboratories, the amount of light, from an electric bulb, absorbed by the film is determined by a photo-electric cell.

For Long Time Burning Oils and similar products the burning tests are run over a considerable period of time in the types of lamp used in practice. The methods used are described under I P T Serial Designation L T B O 35, and A S T M Designation D 219-36 (for Long Time Burning Oils), and A S T M Designation D 239-30 (for Mineral Seal Oil).

A possible criticism of these burning tests is their failure to evaluate the actual intensity of illumination, no photometric method being at present standardized in America or Great Britain. See, however, Kerosene p 1401. In Germany the Physikalisch Technischer Reichsanstalt method, and the Weber photometer are used (both incorporating the Lummer-Brodhum photometer), the initial intensity and that after varying times of burning being usually measured (Holde [10, 1933]). The Weber photometer, from its convenience and simplicity, has been widely used in other countries, while the methods available for determining the intensity of illumination of safety lamps and gas flames may be adapted for testing the illuminating power of kerosenes. (For discussion of the illuminating power of oil lamps, see Thomas [19, 1927], and Baker [1, 1932-3]). The introduction of the 'smoke-point' test has, however, provided an alternative method by which the illuminating power can be estimated.

The Tendency to Smoke of a Kerosene.

Kewley and Jackson [12, 1927] have shown that an approximately linear relationship holds between the mutual illuminating power and the height to which the flame can be turned without smoking, and consider that for practical purposes this 'tendency to smoke' test can replace a photometric method. Based on this the Smoke Point Test has recently been standardized under I P T Serial Designation K 36. The apparatus (Fig 8) comprises a simple lamp with cylindrical wick, provided with a scale for measurement of flame height and a white background for facilitating detection of smoke. The maximum height in millimetres to

which the flame can be turned before smoking is recorded as the IPT Smoke Point (cf Terry and Field [18a, 1936])



FIG 8 Smoke-point lamp (IPT)

The tendency of a kerosine to smoke is determined by its chemical character (increasing with the aromatic and naphthene content) and its boiling-range. According to

Minchin [13, 1931], the relative tendencies to smoke of aromatics, naphthenes, and paraffins is in the order 42.4 : 13.1 : 4.4. On this basis Gilbert [7, 1933], has correlated the smoke point with percentage loss to 98% sulphuric acid. The smoke points of typical kerosines range from about 12 for an inferior grade to 20 for an average cheap grade and as high as 40 for the finest quality.

Chemical Constitution and Significance.

The methods available for the hydrocarbon analysis of kerosines are essentially those described for gasoline and light distillates. In addition may be mentioned the work of Carpenter [2, 1928], particularly in extending the utility of the amine-point method to the heavier distillates.

A considerable amount of work has been carried out on the correlation of illuminating characteristics with chemical constitution (Edeleanu [5, 1907, 1923], Danaila [3, 1930, 1932], Grote [8, 1932]). In general it has been shown that paraffin hydrocarbons possess the best illuminating power, followed by naphthenes and lastly aromatics. Due to their instability, unsaturated hydrocarbons are very undesirable. Hydrocarbons with high carbon-hydrogen ratio (aromatics and to a less degree naphthenes) produce flames of poor luminosity, more susceptible to draughts, and with a greater tendency to smoke, when compared with the paraffin hydrocarbons of such a kerosine as Pennsylvania. These aromatic spirits can, however, be burnt satisfactorily in suitably designed lamp burners, permitting a greater supply of air to be directed on the flame.

REFERENCES

- 1 BAKER, *Proc Inst Rly Sig Eng* 11, 247 (1932-3)
- 2 CARPENTER, J A *J I P T* 12, 518 (1926), 14, 446 (1928)
- 3 DANAILA, N, and others *Peir Z* 26, 47 (1930), 28 (17), 1 (1932)
- 4 DOWNER, R *J I P T* 17, 242 (1931)
- 5 EDELEANU, L *Z angew Chem* 26, 573 (1923), cf EDELEANU, L, and GANG *Repts 3rd Inter Petr Cong* 2, 665 (1907)
- 6 FORTICH, A R, and WILSON, R E *Ind Eng Chem* 17, 291 (1925)
- 7 GILBERT, C L *Proc World Petr Cong* 2, 735 (1933)
- 8 GROTE, W, and HUNTSCHOKER, E *Peir Z* 28 (28), 9 (1932)
- 9 HILLMAN, E S *Proc World Petr Cong* 2, 708 (1933)
- 10 HOFER, D *Kohlenwasserstoffle u. Petre*, 7th ed (1933)
- 11 JACKSON, J S *Proc World Petr Cong* 2, 699 (1933)
- 12 KEWLEY, J, and JACKSON, J S *J I P T* 13, 364 (1927)
- 13 MINCHIN, S T *J I P T* 17, 102 (1931)
- 14 MOERBELL, B H *Proc World Petr Cong* 2, 703 (1933)
- 15 ORMANDY, W R, and CRAVING, E C *J I P T* 8, 145 (1922), 9, 33 (1923), CRAVING, F C, and BANKS, B G, *ibid* 8, 490 (1922)
- 16 VAN STRONEN, G H *Proc World Petr Cong* 2, 717 (1933)
- 17 STANFIELD, R, and STARK, A R *Proc World Petr Cong* 2, 706 (1933)
- 18 STRANOFF *Grundlagen der Lampentheorie*—S Aismann (1906)
- 18a TERRY, J B, and FIELD E *Ind Eng Chem, Anal Ed* 8, 293 (1936)
- 19 THOMAS, W H *J I P T* 13, 402 (1927)
- 20 WATERMAN, H I *J I P T* 11, 576 (1925)

GAS OIL

Gas oil—the petroleum fraction intermediate between kerosine and lubricating oil—is principally used as cracking stock for gasoline manufacture and the production of carburetted water gas, as a absorption oil in the recovery of natural gasoline, and as Diesel fuel. The testing of Diesel fuels is dealt with elsewhere, and the specifications for absorption oils on p 1428.

For gas-making purposes the normal specification tests called for are distillation range, gravity, sulphur, carbon residue, and pour-point, in addition viscosity and water content may be required. The use of laboratory tests for the actual evaluation of gas oils, as regards their efficiency for gas-making purposes, is dealt with subsequently.

Distillation.

The distillation of gas oils may be carried out in the standard Engler apparatus used for kerosines. For oils intended for the manufacture of gas, a larger apparatus is specified in order that the fractions obtained shall be suffi-

ciently large for further testing if necessary. In the standard method for gas oils under A S T M Designation D 158-28, and I P T Serial Designation G O 3, a 250-ml distilling flask is specified with the standard equipment used for the Engler distillation. 200 ml of the oil is distilled to a maximum of 700° F (371° C) and each 50° F (10° C) fraction is separately collected and tested for gravity.

It is desirable that an oil for gas manufacture should have a fairly narrow distillation range with uniformly rising boiling-point. Light volatile oils are somewhat resistant to cracking, while heavy oils tend to yield carbon and hydrogen with resultant lowering of efficiency. The inclusion of distillation range in the specification can ensure the absence of an undue proportion of light and heavy ends.

Specific Gravity.

The inclusion of specific gravity in gas-oil specifications is of value in that an oil of low gravity for a given distillation range will contain a preponderance of paraffinic

constituents of greatest value for cracking purposes in the manufacture of gas

Sulphur.

The total sulphur content is determined by the oxygen-bomb method used for fuel oils (p 1430), described under I P T Serial Designation G O 4, and A S T M Designation D 129-33. The sulphur content of an oil for gas manufacture has no definite relation to the quantity and type of sulphur compounds formed in the resultant gas, nor to their ease of removal. It is sometimes considered that a high sulphur content together with a high carbon residue leads to the formation of carbon disulphide. In general, the sulphur in the gas can be satisfactorily removed by the usual desulphurization methods. Maximum sulphur limits in gas oils range from about 0.3 to 1.0%.

Carbon Residue.

The carbon residue of gas oils is determined by the Conradson or Ramsbottom methods used for lubricating oils. The latter method is in use in Great Britain only. The carbon residue of a gas oil is an indication of the amount of coke formed in the cracking stoves of the carburetting plant. Such coke represents both a loss in gas yield and a reduction in the efficiency of the plant.

Viscosity.

The viscosity of a gas oil is usually determined in the B S I U-tube, or Vogel-Ossag viscometers (p 1411). Specifications sometimes call for the viscosity to be determined in the Redwood or Saybolt instruments, but the use of these instruments for oils of such low viscosity is to be deprecated. The viscosity is of importance only as regards the pumping of the oil, and for this the pour-point must also be taken into consideration.

Pour-point.

Gas oils are sufficiently high in boiling-range to contain appreciable amounts of wax, if prepared from paraffin or mixed base crudes. To obviate pumping difficulties at low temperatures, with segregation of wax in storage, the pour-point is included in specifications. The pour-point (or setting-point) is determined by the methods available for lubricating oils.

Water

Water is obviously an undesirable constituent of gas oils and is determined by the centrifuge or distillation methods specified for fuel oils (p 1431).

Flash-point.

The flash-point is sometimes included in specifications, although it is rare for a gas oil to contain such light components as to constitute any fire hazard. As an indication of the volatility, the flash-point is far inferior to the distillation test. The flash-point is determined in the Pensky-Martens closed tester, or in the open cup apparatus described under lubricating oils.

Calorific Value.

The calorific value is of importance in judging an oil for gas manufacture, and can give a useful indication of the general character of the oil. It is determined in the bomb calorimeter used for fuel oils (p 1430).

Chemical Evaluation.

The nature of the gaseous and other products from the cracking of a gas oil depends on the chemical and physical characteristics of the oil, in addition to the conditions of pyrolysis, the value of an oil for gas making may thus be investigated in the laboratory either by means of a small scale cracking plant, or by investigation of its chemical and physical characteristics.

The value of an oil can be expressed by the 'Hempel Index' (product of amount of gas produced and its calorific value, per unit of oil), by the 'Efficiency' figure of Griffiths (total gaseous therms produced per gallon of oil), by the 'Conversion Efficiency', 100 (B Th U's per gallon of oil to gas)/B Th U's per gallon of *cymene*, or by an arbitrary relative figure.

If an efficiency figure can be assigned to each of the hydrocarbon classes present in the oil, then the efficiency of the oil may be calculated if the proportions of the hydrocarbons in the oil are determined. Paraffins are found to be of greatest value, and Mighill [9, 1927, 1930] suggests the relative efficiencies as paraffins = 100, naphthenes = 70, aromatics = 50, and unsaturateds = 25. His method of analysis is to absorb olefines in cold concentrated sulphuric acid, the aromatics are estimated by nitration at low temperatures, and the naphthenes in the residual oil are finally oxidized to naphthenic acids with a mixture of nitric and sulphuric acids.

Griffith [4, 1929], on the other hand, correlates the content of aliphatic hydrocarbons (paraffins + olefines, as contrasted with the cyclic naphthenes and aromatics) with the oil efficiency as determined by small-scale cracking. His analytical procedure is first to determine the distillation curve of the oil. The unsaturateds are then absorbed with 80% sulphuric acid (distilling to the original end-point to remove polymers), and the aromatics with 96% acid, the residual oil is then examined for paraffins and naphthenes by the Aniline-point method in conjunction with the distillation curve.

A simplified procedure, based on the percentage of constituents absorbed in 100% sulphuric acid, has been put forward by Wing [14, 1924, 1930], (efficiency of absorbables = 50%, of residuals = 80%).

The value of these chemical methods of evaluation has been discussed at the Proceedings [11, 1931], of the American Gas Association, and the view is there expressed that these methods will continue to be used by the smaller gas companies, while the large concerns will rely more on small-scale cracking equipment.

The physical characteristics of an oil give some indication of its value, and the inclusion of boiling-range and gravity in specifications is based on the low gravity and high boiling-point characteristics of paraffinic oils.

Holmes [8, 1932] has proposed the optical dispersivity for this purpose, using the formula

$$G = \frac{238}{\sqrt{T(1-d)}} \frac{1}{H}$$

G = gallons of oil per 1,000 cu ft of 530 B Th U gas,
 T = average B P in ° F,
 d = Sp gr, at 100° F,
 H = dispersivity at 100° F

The value of this method is attested to by Schlapfer and Schaffhauser [12, 1933], who also suggest the use of the hydrogen content of the oil. Van Dujn [2, 1933-4] has

similarly used the specific refractivity, based on the work of Vlугter, Waterman, and Van Westen [13, 1932]

For an account of the Laboratory Cracking methods used, reference should be made to the work of Downing and Pohlman [3], Griffith [4, 1929, 5, 1928, 1933], and Murphy [10, 1930] (see also Holde [7, 1933] for methods used in Germany)

Hydrocarbon Analysis

Due to its comparatively small technical significance relatively little work has been carried out on the hydrocarbon analysis of gas oil and similar distillates. The

methods of Mighill and Griffiths have been mentioned and should be considered with due regard to those available for the lighter distillates and those used for lubricating-oil fractions

Vlугter, Waterman and Van Westen [13, 1932] have utilized specific refractivity in conjunction with the aniline-point for investigating the constitution of the naphthenic constituents of heavy distillates after removal of the aromatics, further investigations of the aniline-point method are contained in papers by Griffith and Hollings [6, 1933], and Carpenter [1, 1926, 1928], in which their application to high molecular weight naphthenes and paraffins is discussed

REFERENCES

- 1 CARPENTER, J. A. *J I P T* 12, 518 (1926), 14, 446 (1928)
- 2 VAN DIJK, J. A. *Het Gas* 53, 449 (1933), *Chem Abt* 28, 885 (1934)
- 3 DOWNING and POHLMAN. *Proc Amer Gas Inst* 2, 588
- 4 GRIFFITH, R. H. *J S C I* 48, 252 T (1929)
- 5 GRIFFITH, R. H. *J S C I* 47, 21 T (1928), cf HOLLINGS, *Manufacture of Gas, 1, Water-Gas*, chap III (1933)
- 6 GRIFFITH, R. H., and HOLLINGS, H. *J I P T* 19, 701 (1933)
- 7 HOLDE, D. *Kohlenwasserstoffe u. Fette*, 7th ed., 245 (1933)
- 8 HOLMES, A. *Ind Eng Chem* 24, 325 (1932)
- 9 MIGHILL, T. A. *Proc Amer Gas Assoc* 1927, 1454, cf BREWER, J. E., *ibid* 1930, 1201
- 10 MURPHY, E. J. *Gas Age-Record* 65, 389 (1930)
- 11 ——. *Proc Amer Gas Assoc* 1931, 974
- 12 SCHLAFFER, P. and SCHAFFHAUSER, S. *Gas J* 203, 676 (1933)
- 13 VLUGTER, J. C., WATERMAN, H. I., and VAN WESTEN, H. A. *J I P T* 18, 735 (1932), 21, 661, 701 (1935)
- 14 WING. *Proc Amer Gas Assoc* 1930, 1189, cf HOLMES, A., *Ind Eng Chem* 16, 258 (1924)

THE LABORATORY TESTING OF LUBRICATING OILS

By Professor A. W. NASH, M.Sc., M.Inst.P.T., and F. C. HALL, Ph.D., A.M.Inst.P.T.

Department of Oil Engineering and Refining, University of Birmingham, England

THE widely varying conditions present in modern engineering practice necessitate the selection of lubricants of specialized characteristics suited to specific cases of lubrication. The final criterion of the suitability of a lubricating oil is its actual behaviour in the machine. Laboratory tests, embodied in a specification, provide a means for the broad classification of lubricants and for securing the approximate duplication of a given product. When properly specified and interpreted, such tests can be of value for the comparison and evaluation of different products. Their correct interpretation, however, is only possible through wide practical experience and knowledge of the conditions met with in practice, of the behaviour of different lubricating oils under these conditions, and of the significance and value of the testing methods applied.

Given this, laboratory tests will suffice to determine the suitability of a lubricant in cases where the conditions of lubrication are understood with reasonable certainty. When the factors governing satisfactory lubrication are not well understood, the behaviour of the lubricant in service may prove the only criterion of value. Particularly does this apply in the case of high-efficiency internal-combustion engine practice, of transmission-gear mechanism under extreme conditions of bearing pressure, and when dealing with lubricants of a type whose behaviour has not been previously investigated.

The testing methods to be considered may be divided as follows

PHYSICAL	Specific gravity	
	Viscosity	
	Cold test	
	Colour	
	Flash-point	
	Analytical distillation	
	Volatility	
	Demulsification	
	Oilness	
	CHEMICAL	Carbon residue
		Oxidation
Unsaturation		
Asphalt		
Saponifiable matter		
Acidity		
Corrosion tests.		
Ash.		

For the purpose of further classification these may be considered to belong to three groups firstly, tests which evaluate properties of importance in service, including viscosity, cold test, oxidation stability, carbon residue, and demulsification, secondly, those which indicate the degree of refining and the presence of contaminants, including asphalt, acidity, corrosion tests, ash, water, sediment, and, to a less degree, flash-point, others such as specific gravity and colour are still included in some specifications, although of little or no importance unless for purposes of classification.

The viscosity of a lubricating oil, or its resistance to

flow, at the temperature attained under operating conditions, is of primary importance. Under given conditions of load, bearing speed, and lubricant supply, this factor, in part conjunction with the oilness, governs the formation of a fluid lubricating film and also the viscous frictional losses in the bearing system. For this reason it is essential to select a lubricant of sufficient viscosity to maintain a lubricating film under the expected conditions and to avoid excessive viscosity which would cause undue frictional losses.

Viscosity is profoundly affected by temperature, and the viscosity-temperature relationship of an oil (as expressed by the Viscosity Index) is a highly specific characteristic. Where wide variation in operating temperatures is encountered, as with automobile and aircraft engine lubrication, the viscosity-temperature coefficient of the lubricant is of considerable importance, and value is attached to oils which show a minimum change in viscosity under these conditions.

The flow of lubricating oils at low temperatures is restricted by the solidification point, and pour- and setting-point tests are available for the evaluation of this factor. The importance attached to such tests will depend on the temperature encountered by the oil in practice as well as by the significance which can correctly be assigned to such tests. Exceedingly low pour-points are essential in refrigerator lubricating oils, while climatic conditions will limit this factor in most other cases.

In bearing systems operating at high temperatures under oxidizing conditions, the resistance of the lubricant to these factors is of considerable importance. Some form of oxidation test is usually specified for steam-turbine oils, and is becoming increasingly recognized as an important criterion of lubricating oils for internal-combustion engines. The necessity for stability towards oxidation becomes more pronounced in lubricating systems where the lubricant is recirculated over prolonged periods. At sufficiently high temperatures, even in the absence of oxidation, lubricating oils undergo distillation and cracking with production of a carbonaceous residue. Deleterious carbon deposits produced in this manner are a factor of considerable importance in the lubrication of internal-combustion engines and air compressors, and carbon-residue tests have been evolved for determining this property of an oil.

In certain circulatory systems of lubrication in which water or steam is present, the rapid separation of the lubricating oil from emulsions formed with water is essential. The evaluation of this property of demulsibility is of the greatest importance for steam-turbine lubricating oils.

These latter, more specialized testing methods have been developed for specific classes of lubricants, and, in general, are applicable only to them. Unfortunately they have been and still are misapplied to other types of oils for which the test may have no valid significance. Demulsibility tests have been specified for oils used in lubrication systems in which water does not enter, or used under such conditions

of contamination as will at once invalidate this property. High oxidation-stability and low carbon-residue values may be specified for oils used in simple shaft lubrication, in which conditions of high temperature and oxidation are never approached. In drawing up specifications it is of the utmost importance to avoid the inclusion of tests of no essential or practical significance for the particular oil and conditions of lubrication under consideration. It is of equal importance to allow a reasonable degree of latitude for the properties evaluated in the specification. Too rigid insistence upon specified limits for viscosity and other characteristics has frequently resulted in the exclusion of products better suited for the purpose from the standpoint of performance or economic considerations, or even, in extreme cases, to the exclusion of any commercially available product whatsoever.

The factor of oiliness has been referred to previously. This may be defined as that property of a lubricant which reduces the friction between rubbing surfaces in comparison with another lubricating medium, of similar viscosity, operating under identical conditions. Oiliness is probably connected with the 'wetting power' of a lubricant for the bearing surfaces, assisting the initial formation of a lubricating film. This property would appear, then, of considerable importance. In practice, however, where fluid film lubrication is attained in the majority of cases, the oiliness has practically no effect upon the frictional resistance. This is determined, under these conditions, by the viscous flow of the lubricating-oil film.

Under certain conditions of low speed and high pressure the formation of a fluid film is prevented or delayed. Particularly is this observed when starting and stopping a bearing system, at the limits of the stroke in reciprocating machinery, and in worm-gear transmission. There may, then, exist a case for the selection of lubricants possessing a high degree of oiliness, and the virtue of compounded and doped lubricants for certain extreme pressure conditions is well known.

Compounded oils, in which a fatty oil is blended with a petroleum lubricant to confer on it some of its own particular characteristics, are used to a much smaller extent now than formerly, but still find some applications for marine reciprocating steam engines (no superheat) and in some kerosene and gas engines. The value of compounding agents other than fatty oils, for the improvement of lubrication under severe conditions, either by enhancing the factor of oiliness or by increasing the resistance to oxidation, is receiving some attention. The presence of fatty oil is shown by the saponification value and may result in an appreciable organic acidity. The demulsification test is never applied to compounded oils, while oxidation tests are found to yield results of very questionable value.

Specific Gravity

The determination of the specific gravity of petroleum products is described elsewhere (p 1393). The standard methods, using the hydrometer, pycnometer, or specific gravity bottle, are detailed under the respective standards—I P T Serial Designation L O 1, and A S T M Designation D 287-36. The data may be expressed in specific gravity units at 60/60° F., or in API degrees.

The specific gravity of lubricating oils, apart from its use in the interconversion of weight and volume measurements, has lost much of its earlier significance. For lubricating fractions prepared from a given type of crude

the specific gravity increases with increase in the viscosity and, in such cases, may be used for the purpose of classification in place of the latter property. In the case of unblended oils it is an indication of the type of crude from which the oil is derived, the paraffin-base oils, such as Pennsylvanian, possessing low specific gravities (high API gravities) and high flash-points for a given viscosity compared with naphthene and asphalt-base oils. The viscosity-gravity constant of Hill and Coats [52, 1928] is based on this distinction. Modern practice in solvent refining, hydrogenation, and blending of lubricants has reduced the significance of this factor, although the specific gravity remains a useful indication of the paraffinic character of an oil, in addition to its value for re-identification purposes. For steam-cylinder oils, a low specific gravity with a high flash-point is regarded as a useful indication of a Pennsylvanian origin, most suitable for this class of oil. As a very approximate guide for the heavier lubricants, paraffin-base oils have API gravities of the order of 25 to 30 (specific gravities of 0.91 to 0.88), while asphalt-base oils range from 12 to 20 (0.99 to 0.94).

Determination of the specific gravity is widely used in plant control for following the progress of refining operations, particularly in the case of solvent-extraction processes.

Viscosity

The definition and physical significance of viscosity are discussed elsewhere. Its significance from the point of view of lubricating oils has been summarized as follows:

'For lubricating oils viscosity is the most important single property. In a bearing operating properly, with a fluid film separating the surfaces, the viscosity of the oil at the operating temperature is the property which determines the bearing friction, heat generation, and rate of flow under given conditions of load, speed, and bearing design.'

When no fluid film separates the surfaces, boundary lubrication is said to ensue and the 'oiliness' of the lubricant is then of importance.

'The oil should be viscous enough to maintain a fluid film between the bearing surfaces, in spite of the pressure tending to squeeze it out. While a reasonable factor of safety is essential, excessive viscosity means unnecessary fluid friction and heat generation. Since the rate of change of viscosity with temperature varies with different oils, viscosity tests should be made at that standard temperature which approximates most closely to the temperature in use. In the case of lubricating oils for automotive equipment, the viscosity of the crankcase oil at low temperatures is one of the many controlling factors of the ease of starting in cold weather' [1, 1934].

The importance of viscosity is illustrated by its general use for the classification of lubricating oils. The viscosity of industrial lubricating oils covers a very wide range, from mobile spindle oils to extremely viscous cylinder stocks, as may be seen from the table on the following page.

The viscosity of an oil is generally determined at one or more standard temperatures which may be appreciably different from the temperatures encountered under operating conditions. The variation in the viscosity of an oil with temperature is dependent upon the character of the oil. Given the viscosity at two temperatures, the coefficient of viscosity change with temperature can be expressed in suitable units, and the viscosity at a third

Type of oil	Spindle oil and light machine oils	Medium and heavy machine oils and internal-combustion lubricants	Steam-cylinder oils
Viscosity in Redwood No 1 sec at 70° F „ 140° F	150-750	750-4,000 100-260	500-1,750
Viscosity in Saybolt Universal sec at 100° F „ 130° F	90-320	120-1,170 150-400	750-2,750

temperature calculated. For practical purposes this may conveniently be carried out on the ASTM Viscosity Temperature Chart (ASTM Designation D 341-32 T), which is so constructed that the variation of viscosity with temperature of an oil, when plotted on this chart, is shown by a straight line. Given the viscosity of an oil at two temperatures, its viscosity at other temperatures is obtained by simple interpolation or extrapolation. At low temperatures the viscosity so determined is of value in predicting the torque to be expected in a bearing system at this temperature. At temperatures approaching the pour-point, the viscosity of an oil, whether calculated from the viscosity at higher temperatures or measured directly, is an unreliable characteristic. A complete investigation necessitates measurement of the viscosity at different rates of shear, and, even so, the data obtained are of questionable utility.

The relationship between the viscosity and temperature of lubricating oils is discussed in detail on p 1083. A convenient practical measure of the change in viscosity of an oil with temperature is given by the Viscosity Index (p 1091). Lubricants exhibiting a rapid diminution in viscosity with increase in temperature have low viscosity indices, unprocessed oils from Gulf Coast crudes, for example, having values in the neighbourhood of zero. Paraffin-base oils, particularly from Pennsylvania crudes, show a less rapid change in viscosity and have viscosity indices as high as 100.

Unreliable and anomalous viscosity data are occasionally obtained at the lower standard temperatures. This is not infrequently found with blends containing heavy residual stock and especially with black asphaltic oils which may exhibit pronounced hysteresis effects. In such cases this can be minimized by adopting a standard thermal pretreatment, and in the IPT standard method for viscosity determination (Serial Designation LO 8) it is specified that the sample shall be heated at 212° F for 1 hr, and allowed to remain at room temperature for 24 hr, before the determination.

Industrial Viscometers.

Industrial viscometers for testing lubricating oils are usually of the short tube efflux type, in which the time of outflow of a definite quantity of oil is observed. For the Redwood and Saybolt viscometers, this time of outflow, in seconds, is reported at the Redwood, or Saybolt, viscosity of the oil. Owing to turbulence effects these instruments are, in general, useless for mobile liquids having efflux times lower than 30 or 40 sec. In the case of the Redwood and Saybolt instruments, with careful working, results can be obtained accurate to within 1%, but with the Engler the accuracy cannot, in general, be regarded as greater than about 3%. Their robustness and simple manipulation have

rendered them more acceptable for industrial practice than the more fragile capillary tube viscometers of considerably higher precision, although the latter instruments are being used to an increasing extent.

These instruments (Redwood, Saybolt, and Engler) consist essentially of an oil cup with oil-level gauge, fitted with a calibrated jet at the lower end. The oil flow can be interrupted by a suitable stopper, and the oil is maintained at the desired temperature by a surrounding bath. For a given temperature, the time of efflux is proportional to the viscosity of the oil, over the greater portion of the range of the instrument, according to a relation of the type.

$$\mu = \frac{\eta}{d} = At - \frac{B}{t}$$

where μ kinematic viscosity of oil (in centistokes),

η absolute viscosity of oil (in centipoises),

d density of oil at the same temperature,

t time of efflux,

A and B = constants for the instrument,

and in which the second term may be regarded as a kinetic energy correction, negligible for very slow rates of flow.

The interconversion of viscosity readings in the accepted industrial units (Redwood, Engler, and Saybolt) and their relationship to absolute units of viscosity is dealt with in detail on p 1076.

The Redwood Viscometer, used in Great Britain, is standardized under IPT Serial Designation LO 8. It

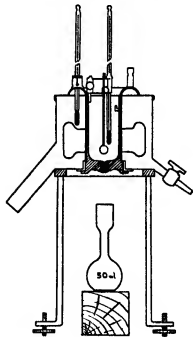

FIG. 1 Redwood No 1 Viscometer

is made in two distinct models the Redwood No 1 Viscometer (Fig 1) for oils with times of flow below 2,000 sec, and the no 2 instrument for more viscous oils. The time of flow with the no 2 viscometer is approximately one-tenth that in the no 1 instrument. A modified form of the no 2 viscometer, the Admiralty Pattern Redwood Viscometer, is designed for testing fuel oils at low temperatures for British Admiralty Specifications [see Redwood, *A Treatise on Petroleum* (iii), 825 (1922)]

The Redwood viscosimeter is fitted with an agate jet which may be closed by a ball-ended plunger. The capacity of the oil cup is approximately 135 ml, and the time of efflux of 50 ml is observed and recorded in seconds. Viscosity determinations are usually carried out at one or more of the following temperatures: 70° F, 100° F, 140° F, 200° F, 250° F. The no. 1 instrument is unsuitable for viscosity measurement at temperatures greatly exceeding 200° F, but the no. 2 viscosimeter may be used at temperatures up to 420° F. The bath liquid (usually water or oil) may be heated by gas or electrically, according to the design, and the use of a multiple-cup bath, in which any number of oil cups may be fitted and operated, is now recognized under the tentative method, I P T Serial Designation L O 8a (r).

The instruments should be examined and certified at the National Physical Laboratory, the no. 1 viscosimeter being compared with a Standard No. 1 Reference Viscosimeter for times of flow of 60 sec and 300-500 sec, while the no. 2 instrument is subjected to a flow test in comparison with the No. 1 Reference Viscosimeter.

Conversion factors, by which the viscosity may be approximately estimated from the times of flow of smaller quantities of oil, have been given by Evans [27, 1933].

The Saybolt Viscosimeter, used in the United States, is standardized under A S T M Designation D 88-36. It is made in two models: the Saybolt Universal Viscosimeter (Fig. 2) for lubricating and similar oils, and the Saybolt

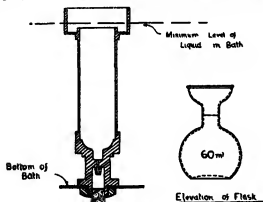

FIG. 2 Saybolt Universal Viscosimeter—oil cup and flask

Furol for fuel oils and other oils of similar viscosity, the out-flow time of the Furol instrument being approximately one-tenth that of the Universal. The instrument is fitted with a jet of a suitable hard and non-corrosive metal, which may be closed by insertion of a cork stopper into a tubular extension below the jet. The oil level is automatically adjusted by an overflow gutter around the rim of the oil cup. In carrying out a determination, approximately 70 ml of oil is required, the time of efflux of 60 ml being observed and recorded in seconds. The temperatures used for the test are selected from the following: 100° F, 130° F, and 210° F for the Universal viscosimeter, and 77° F, 100° F, 122° F, and 210° F for the Furol instrument. Any construction of bath is acceptable, provided it is capable of maintaining the standard temperatures with the requisite degree of accuracy.

The oil tubes should be standardized either by comparison with a certified tube, by use of an A P I standard oil, or directly by the Bureau of Standards. It is specified that the time of flow should be within $\pm 1\%$ of the time as obtained with the Bureau of Standards master tube.

The construction and use of a micro-Saybolt viscosimeter for small samples of oil (12 ml.) has been described by Rogers and Adkins [84, 1928], while Winning [111, 1930] has used an adapter by which the standard Saybolt instrument can be used on samples of 15 ml., though with some loss in accuracy. The latter author also finds that the efflux time of 28.5 ml from the Saybolt Universal is exactly one-third that of the full 60 ml.

The Engler Viscosimeter (Fig. 3), used in Germany and on the Continent, is now standardized under the specification D V M 3,655. The oil cup, fitted with platinum jet, has a capacity of no less than 240 ml., the efflux time of 200 ml being determined. The oil flow is interrupted by a wooden spike inserted in the jet, and the oil level is adjusted to three radial gauge points.

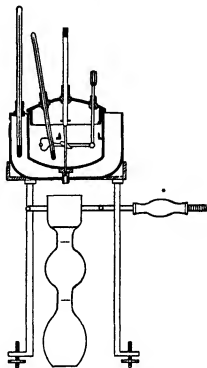

FIG. 3 Engler Viscosimeter

The viscosity of an oil is expressed in Engler degrees ($^{\circ}E$) obtained by dividing the time of flow of the oil by that for water at 20° C. The time of flow for water should lie between 50 and 52 sec at 20° C, and determination of this figure is considered to represent the necessary calibration of the instrument. Conversion factors by which the viscosity may be estimated from times of flow of less than 200 ml of oil have recently been revised by Bleyberg [10, 1928] and are included in the above specification.

A modified design of the Engler viscosimeter, overcoming certain disadvantages inherent in the earlier instruments, has been devised by Holde [54, 1918, 1933].

The Barbey Isometer has been used in France, but is being replaced by the Engler and other instruments. This viscosimeter is different in design to the preceding, the oil flows by gravity, under a constant head, through a long concentric passage, and the rate of flow—in ml per hour—is determined. The results are expressed in degrees of fluidity on the basis of 100° representing the fluidity of pure rape oil at 35° C. For the conversion of Barbey degrees

(*F*) to kinematic viscosity in centistokes (μ), Evans [27, 1933] has given the following equation

$$\mu = \frac{5,750}{F}$$

Industrial Instruments for the Determination of Viscosity in Absolute Units.

Viscometers used for the measurement of the viscosity of petroleum products in absolute units can be constructed for a much wider range of viscosities than is covered by the short tube efflux type described above. They are generally modifications of the simple pipette type with long capillary tubes, constructed in glass. The proportions of the capillary and the instrument as a whole are selected so that true stream-line flow exists, while the kinetic energy correction is usually rendered negligibly small. With the oil flowing under gravity, the time of flow is then proportional to the kinematic viscosity, while, if under an artificially maintained pressure, it is proportional to the absolute viscosity. The results may be obtained with a degree of precision greater than 0.5%. These instruments are normally calibrated with liquids of known viscosity—such as sucrose or glycerol solutions—and require a considerably smaller volume of liquid than the previously described viscometers.

The Ostwald type U-tube viscometer has been widely used. In this instrument the oil is contained in a U-tube, one limb of which forms a reservoir for the oil, while the other comprises a capillary tube surmounted by a bulb into which the oil may be drawn by suction. The time of flow of the oil under gravity from the bulb is determined and is proportional to the kinematic viscosity.

In Great Britain the British Standards Institution has published specifications of five U-tube viscometers (Fig. 4) covering a range of 0.5 to 1,500 centipoises. Their construction, standardization, and use are described in B.S.I. publication no. 188, 1937. This specification has been adopted under I.P.T. Serial Designation G 8 for the determination of Kinematic Viscosity in Absolute Units. A series of modified Ostwald viscometers, for the determination of the viscosity of lubricating oils at different temperatures (in conjunction with the determination of Viscosity Indices) has been described by Fenske and McCluer [29, 1934]. In these instruments the bulbs are superposed in order to diminish any error due to deviation of the capillary from the vertical (see also Barr [7, 1931]). A series of four such viscometers is described in the *ASTM Standards on Petroleum Products and Lubricants* (1936, Appendix II).

The Ubbelohde 'suspended level' viscometer, described by Ubbelohde [100, 1933] and Fitzsimons [30a, 1935-6], is becoming increasingly used in Great Britain and the United States. In this modification of the Ostwald instrument, the oil discharge from the capillary is automatically maintained at a constant level, the manipulation being particularly convenient and rapid (see *ASTM Standards on Petroleum Products and Lubricants*, 1936, Appendix I).

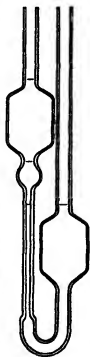

FIG. 4 B S I
U-tube viscometer

The Vogel-Ossag viscosimeter, standardized by the German Reichsanstalt and adopted as standard in Belgium under A.B.S. 52.12, is also widely used. The instrument consists of a pipette discharging into an oil reservoir, provided with an overflow gutter so that the initial level of oil in the reservoir can be maintained constant, a 15-ml sample being sufficient for the determination. The oil is allowed to flow from the pipette under gravity or it may be drawn up under a constant negative pressure (see Holde [55, 1933]). The U.F. Viscosimeter, tentatively standardized in France under specification A.F.N.O.R. B 6-21, is essentially a simplification of the Vogel-Ossag, the overflow gutter being dispensed with. Either downward flow under gravity or upward flow under a reduced pressure may be utilized.

Two viscometers of unusual design, the Steiner and Hoppler instruments, were recently described at the World Petroleum Congress in 1933. In the Steiner viscometer [95, 1933-4] the oil (about 5 ml), together with a bubble of air, is contained in a glass tube which may be inverted about a Cardon joint. The time taken by the air bubble to rise from one mark to another on the tube is observed and is proportional to the kinematic viscosity of the oil. The Hoppler instrument [57, 1933], for which a very wide range and high degree of accuracy is claimed, is a modification of the falling sphere type, in which the time of fall of a sphere down an inclined tube is measured.

For viscosity determinations on small quantities of oils, sometimes obtained in research investigations, the use of some form of micro-viscometer is essential. The U.S. Bureau of Mines (*Bull.* no. 207, 1922) have utilized small capillary pipettes, with a capacity of about 1.5 ml, which may be calibrated in terms of Saybolt units through a conversion chart or factor. A similar apparatus has been used at the Bureau of Standards in their work on the constitution of petroleum (Mair, Schectanz, and Rose [65, 1935]). The original design of the Lidstone [62, 1917, 1935] mercurial viscometer is also suitable for quantities of oil of less than 1 ml.

Action of Low Temperature—Cold Tests

A true fluid shows progressive increase in viscosity with fall in temperature, the relationship between which may be approximately represented by a linear logarithmic equation. In the case of a lubricating oil, such a relationship rarely holds at low temperatures, being complicated by several factors. Petroleum oils have certain colloidal characteristics which at low temperatures tend to produce a gel-like structure, or congealment of the oil. This is intensified by the presence in the oil of paraffin wax and other crystallizable material, which may be precipitated out either in a crystalline or amorphous form, or may remain indefinitely in the supercooled state, depending on the thermal conditions, the viscosity, and on the inhibiting action of other constituents, particularly asphaltic material.

The behaviour of an oil at low temperatures will thus depend on the nature of the oil, its previous thermal history, and its present thermal treatment. In general, however, this behaviour may be regarded as being composed of two factors: the usual increase in fluid viscosity consequent on the temperature lowering, together with the development of the characteristics of a plastic solid in which the viscosity will vary with the rate of shear.

Four-point and setting-point tests indicate, with a varying degree of precision, the temperature at which an oil ceases to flow under a small applied pressure and under the

arbitrary conditions inherent in the testing procedure. No other more definite significance can be properly attached to the pour-point than this. For a more comprehensive study of the behaviour of a lubricating oil at low temperatures, examination of the apparent viscosity under different thermal conditions and at differing rates of shear is necessary. Up to the present this has only been carried out in research investigations, and no standardized procedure has been adopted. Normal viscometric apparatus (the Saybolt instrument, for example) can be modified for this purpose by the application of air pressure to control the rate of flow of the oil.

The significance of these factors in relation to lubrication at low temperatures may be summarized as follows. The fluid friction in a bearing system at moderately high velocities will depend on the viscosity of the oil at relatively high rates of shear. Under such conditions this viscosity, for an oil at or near its pour-point, will be chiefly determined by the viscosity-temperature relation existing at higher temperatures. The viscous friction will not be excessive, provided this viscosity is of the correct order, but the initial resistance to motion, and that at relatively low speeds, and low rates of shear, may be very high.

The supply of lubricant to the bearing system is largely controlled by the pour-point of the oil, if under gravity or low-pressure feed. It is, perhaps, fortunate that oils can be pumped at temperatures appreciably below their pour-points, but under such conditions the flow is limited in that the effect of congealment of the oil is to reduce the effective cross-sectional area of the oil-feed pipes.

For the lubrication of engines subject to low temperatures it is in general desirable that the lubricating oil should possess both a low pour-point and also a low temperature coefficient of viscosity, to ensure easy starting of the mechanism and effective lubrication on the cold (Lederer and Staley [60, 1929], Wilkin *et al* [110, 1928], McCloud *et al* [71, 1933]).

The pour-point of a commercial lubricant is connected both with its viscosity (increasing with increase in viscosity) and, more particularly, with the content of paraffin wax. Over a limited range the pour-point of a given oil is directly proportional to the amount of wax present in the oil. The effect of residual and especially asphaltic components is to reduce the pour-point of waxy stocks, with the result that, after refining treatment with acid, clay, or selective solvents, the pour-point is frequently found to have increased. The wax content is dependent both on the type of parent crude (high with paraffin-base oils, low or absent with naphthene- and asphalt-base oils) and the refining procedure adopted. In practice the pour-point of the finished product can be controlled within wide limits by the application of dewaxing methods, or, to a less extent, by the addition of pour-point depressants of the type of "Parafflow".

Cloud-point.

The cloud-point of an oil—IPT Serial Designation LO 11, ASTM Designation D 97-33—is the temperature in °F at which wax or other solid substance begins to crystallize or separate out from the oil when cooled under certain specified conditions, and is normally used only on oils transparent in layers $\frac{1}{2}$ in. thick. The apparatus (Fig. 5) is that used for pour-point determination. The oil, contained to a depth of 5 cm in the test-jar, is allowed to cool down and is inspected every 2° fall in temperature. The temperature at which a distinct cloudiness first

appears is reported as the Cloud-point. Methods for the determination of cloud-points in dark oils have been discussed by Verver [102, 1933].

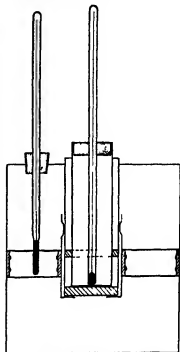

FIG. 5 Cloud- and pour-point apparatus.

The cloud-point of an oil is of value in wick-feed lubrication when the formation of wax crystals interferes with the oil flow. Apart from this, except that certain marketing conditions call for a low cloud-point from its visible indication of the presence of wax or other crystallizable impurity, the cloud-point of a lubricating oil has little or no significance that is not better given by the pour-point test. The test may give misleading results, if the oil is not dry, due to separation of water.

Pour- and Setting-points.

The Pour-point is the simplest method available for determination of the lowest temperature at which the oil will just flow under a small applied stress, produced by tilting the vessel containing the oil. In the method standardized under ASTM Designation D 97-34, and the IPT Serial Designation LO 11, and recently adopted in France, the oil is contained in a cylindrical test-jar of standard dimensions provided with a thermometer dipping into the oil (Fig. 5). The jar is supported in an air jacket surrounded by a cooling bath maintained at the specified temperature, according to the pour-point of the sample. The test-jar is examined every 5° F until, when held horizontal for 5 sec, no movement of the oil is shown. The temperature 5° F above this is recorded as the pour-point. For black oils and cylinder stocks, if the previous thermal history of the sample is unknown, it is necessary to determine the maximum pour-point (as above) and the minimum pour-point after heating to 220° F; the two figures being reported separately.

It is found that this method applied to heavy cylinder oils may give anomalous results, and a modified testing procedure for such oils is being developed. The effect of asphaltic constituents upon the cold test of fuel oils, and

the production of anomalous characteristics, has been discussed by Moerbeek and van Beest [73, 1935]

In Germany the method standardized by the Richtlinien has been used (*Richtlinien*, 6th ed., p. 98), the apparatus and procedure resemble that for the previous method, except that the test-jar is larger (holding 60-ml sample), and is cooled by direct immersion in the cooling bath. The production of low temperatures by the rapid evaporation of ether has been utilized by Stelling [96, 1926] in a similar method.

The Setting-point is standardized under IPT Serial Designation L O 11a, and was introduced as a more precise indication of the temperature at which an oil just ceases to flow, when subjected to a small definite stress, than the pour-point [103, 1927]. The oil is contained in a standard U-tube (Fig. 6), surrounded by an air jacket and cooling bath so that the oil is cooled at the rate of 1° F per min. A thermometer is supported in the oil in one limb of the U-tube, a side arm of which enables air pressure, equivalent to 5 cm of water to be applied to the oil. Any movement of the oil is indicated by movement of a short column of liquid in an indicator tube connected to the other limb of the U-tube. The oil is tested every 1° F until, on applying the air pressure, a slight initial movement of the oil is followed by no further movement after 10 sec. This temperature is reported as the setting-point.

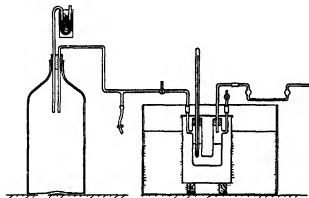

FIG. 6 Setting point apparatus (IPT)

A simplified modification of this method is described by the British Air Ministry in their specification for aircraft lubricating oils (Specification no. DTD 109). The German Reichsbahn also standardize a U-tube cold test in their specifications (Holde [55, 1933], p. 51), and a modification of this has been adopted as standard in Italy.

The Flow-point determination, standardized in France under A F N O R B 6-26, utilizes a very different procedure. A vertical metal tube can slide about the axis of a concentric rod, carrying at its lower end an annular oil reservoir into which the tube can dip. The outer tube is clamped rigidly in a stand, while the inner rod has a limited fall so that the reservoir is lowered away from the tube. The reservoir is filled with the oil under examination, raised so that the tube dips completely in the oil, and the apparatus cooled by partial immersion in a bath of acetone containing a slight excess of CO₂ snow, the bath and apparatus are allowed to warm up slowly, until the congealed oil softens sufficiently for the oil reservoir to fall away from the tube. The temperature of the bath is then recorded as the flow-point [112, 1933].

Colour

The colour of a lubricating oil or other petroleum fraction may be defined by reference to reflected or transmitted light. Although the colour by reflected light (bloom or fluorescence) is a distinctive feature, capable under favourable circumstances of giving information on the origin of the oil, industrial colour measurements are concerned only with transmitted colour.

The colour of an oil may vary with regard to intensity (percentage light transmitted) and quality (range of colour transmitted), Parsons and Wilson [76, 1922] have shown that all paraffin-base oils possess essentially the same colour absorption curves, and although this scarcely applies to petroleum oils in general, industrial measurement is chiefly concerned with the intensity of the transmitted light and not its quality.

Colour measurement is carried out by matching a definite thickness of the oil with an arbitrary colour standard which may consist of coloured glasses or of a coloured liquid by use of the Lovibond series of glasses (red yellow amber, blue) any colour, within a certain range can be analysed and duplicated. The Lovibond scale has disadvantages (cf. Committee D-2 report, A S T M 1936) it is not additive, i.e. the colour of a blend cannot in general be expressed by the simple mixture law, the expression of a colour value by more than one colour series is inconvenient in dealing with petroleum, and finally, the limited range of the scale necessitates the use of solutions of dark oils from which the colour of the solute cannot readily be calculated.

To overcome these disadvantages, True Colour scales have been introduced, in which the colours are truly additive, Parsons and Wilson [76, 1922], Rogers, Grimm, and Lemmon [86, 1926] and Weir, Houghton, and Majewski [108, 1930] have used such scales, based essentially on the use of a standard oil, with which the oils under examination are compared. The oil used is basically standardized against a reproducible Lovibond colour Ferris and McIlvain [30, 1934] have used a True Colour scale based on the optical density of the oil. Using monochromatic light (green) the oil, or its benzene solution, is matched against a neutral light filter of known light transmission, the ultimate standard being an iodine solution of known spectral absorption characteristics. Story and Kalchevsky [97, 1931] have also introduced a True Colour scale utilizing the photo-electric response of a suitable cell.

Measurement of the colour of petroleum oils is carried out in a suitable colorimeter. For approximate colour measurement, for marketing purposes, the Union Colorimeter as standardized under A S T M Designation D 155-34 T, is satisfactory. The apparatus resembles the Lovibond Tintometer in principle, the oil, contained in a standard glass jar, is viewed transversely and matched against a series of standard colour glasses, illumination being provided by a suitable daylight lamp and screen (dark oils, above 8 colour, are diluted with kerosene). The colour standards, ranging from 1 to 8 N P A numbers and from 'hily white' to 'claret red' in description, may be expressed in terms of the Lovibond series (cf. table on succeeding page).

For more precise work, as in plant control, the Lovibond and Duboscq instruments are used.

The original Lovibond Tintometer (p. 1393) had the disadvantage of an unsatisfactory optical system, the two

colour fields appearing widely separated in the eyepiece. This defect is overcome in the recently introduced B D H pattern, but this, like the former design, is more conveniently used for colour evaluation than for colour comparison.

The Duboscq Colorimeter is chiefly used in the petroleum industry for lubricating oils. In this instrument the oil is matched against a standard liquid (a stable petroleum oil, for example) by varying the respective depths under examination (glass colour standards can also be used). The oil and colour standard are contained in adjacent glass jars into which dip transparent plungers attached to a sliding scale, by which the depth of liquid may be varied. The oil layers are viewed through a prismatic eyepiece by which the field of view is divided equally and sharply between the two liquids under examination.

The Tag-Robinson Colorimeter, used to a considerable extent in the United States, resembles the Duboscq instrument in principle, and is described in the *Tag Manual* (C J Tagliabue Mfg Co, N Y). A series of three standard colour glasses is supplied (light, medium, and dark). The depth of the oil layer is varied to match the colour fields in the prismatic eyepiece, and the colour shade read off directly on the Tag-Robinson or N P A scales. The relation between the A S T M Union (N P A), Tag-Robinson, and Lovbond colour standards is given in the two following tables, reproduced from the *Tag Manual*.

Equivalent Colour-shade Table

Tag-Robinson Colorimeter number	National Petroleum Association and A S T M numbers	Approximate Lovbond number 1-in cell 500 series-amber
21	1	15
17½	1½	5
12½	2	20
10	(2½)	
9½	3	55
9	(3½)	
8½	4	120
5	(4½)	
3½	5	220
2½	6	320
2	7	
1	8	
9	A	
5½	D	
2	E	

Photo-electric colorimeters [97, 1933] have been used in some investigatory work, but are rarely used in the industrial laboratory; the colorimeters described being adequate for normal work.

The colour of a dark oil is considered mainly due to dissolved, or colloiddally dispersed, asphaltic constituents, which may be flocculated and removed by solution in sulphuric acid or by adsorption on refining earths. The colour of an oil of known origin is thus some indication of the degree of refining and of the suitability of the oil as a high-class lubricant. For marketing purposes the colour of an oil has little significance, except that a pale colour conveys the deceptive impression of a low viscosity. In the textile and certain other industries, however, the colour of the lubricating oil used is of considerable importance, an oil of low colour being necessary to avoid staining.

In refining processes, the colour of the oil forms a valuable guide to the progress of refining, particularly during acid and earth treatment, and colour determination is therefore used considerably in plant control.

The reflected colour, bloom, or fluorescence of an oil is not usually measured, but may be described by the terms blue, bluish green, or green, the latter being associated with paraffin-base oils and a blue colour with asphalt-base stocks. Henderson and Cowles [49, 1927] have modified the Ives Tint Photometer for evaluating the bloom of lubricating oils, their results being expressed in the form of a colour-absorption graph. The significance of 'bloom' in a commercial product is largely discounted by there being available synthetic compounds, the addition of which will impart a varying degree and character of bloom to an oil.

Flash-point

The flash-point of heavy oils may be determined in a closed or open cup, in the latter method the oil is heated in an open cup until, on application of a test flame, the evolved vapours ignite with a flash on the surface of the oil. The fire-point is obtained by continuing the open-flash determination until a temperature is reached when the oil burns continuously for 5 sec.

In general it is found that the open flash lies about 30° F higher than the closed flash, while the fire-point is some 50° F above this. As would be expected, the open flash-point is much less sensitive to traces of volatile

Glass Colour Standards of Union Colorimeter

A S T M colour numbers	Alphabetic designations	N P A colour numbers	N P A names	Lovbond analysis		
				Red 200 series	Yellow 510 series	Blue 1,180 series
1	G	No 1 N P A	Lily White	0 12	2 4	
1½	H	No 1½ N P A	Cream White	0 60	8 0	
2	I	No 2 N P A	Extra Pale	2 5	26 0	
2½	J	No 2½ N P A	Ex Lemon Pale	4 6	27 0	
3	K	No 3 N P A	Lemon Pale	6 9	32 0	
3½	L	No 3½ N P A	Ex Orange Pale	9 4	45 0	
4	M	No 4 N P A	Orange Pale	14 0	50 0	0 55
4½	N	No 4½ N P A	Pale	21 0	56 0	0 55
5	O	No 5 N P A	Light Red	35 0	93 0	
6	P	No 6 N P A	Dark Red	60 0	60 0	0 55
7	Q	No 7 N P A	Claret Red	60 0	106 0	1 8
8	R	No 8 N P A	Ex Dark Red	166 0	64 0	
A	A	A Cylinder Oil	Ex. Light Filtered	10 2	29 0	
D	D	D Cylinder Oil	Light Filtered	21 0	31 0	
E	E	E Cylinder Oil	Medium Filtered	89 0	56 0	

hydrocarbons than the closed method, and, when the flash-point is needed to give information on the fire hazard on storage or use of the oil, it is necessary to use the closed method. For testing lubricants, the open flash-point is considered more reliable and of greater significance than the closed method.

The flash-point of a lubricating oil is dependent on the nature of the original crude oil and on the manner of preparation of the lubricant, fractions prepared from the same crude show an increasing flash-point with rise of boiling range, specific gravity, and viscosity, the lowest values being shown by spindle oils and the highest by cylinder stocks. The flash-point is closely related to the volatility of the oil, but depending as it does on the more volatile fractions, it cannot give any complete information on the overall volatility of the oil, especially in the case of blended oils.

The flash-point has little of the significance and importance formerly attributed to it. In the case of steam-cylinder oils it is still considered, by some, to be a useful criterion of their applicability, a high flash-point indicating an oil of Pennsylvanian origin less liable to decomposition under the extreme conditions of heat, pressure, and oxidation existing with superheated steam. For other lubricants, apart from its value as an indication of the presence of unduly light fractions, from bad refining or blending, and to the necessity of conforming to existent Board of Trade or Federal regulations, the flash-point might almost be omitted from specifications. The volatility of an oil, where required, can usually be better expressed by other more suitable testing methods. Flash-point tests are of some value to refiners in controlling the manufacturing process, but apart from this they serve only for purposes of classification and identification. An oil of high flash-point was formerly considered to offer the best resistance to spontaneous ignition and explosion in the lubrication of air compressors, the flash-point, however, is no criterion of the spontaneous ignition temperature.

The fire-point has attained some commercial importance from long-established custom. It gives no useful information beyond that obtained from the flash-point and could well be omitted from all specifications.

The significance and methods of determination of flash-points, with particular regard to the position in Germany, has recently been exhaustively reviewed by Holde [56, 1933].

The flash-points of lubricating-oil blends may be approximately calculated from the equation developed by Thiele [98, 1927]

$$F_m = -100 \log [X' (10^{-\frac{F'}{100}}) + X'' (10^{-\frac{F''}{100}})],$$

where F' , F'' and F_m are the flash-points ($^{\circ}$ F) of the two constituents and the blend respectively, and X' , X'' are the volume fractions of the constituents. Thiele also gives a table based on this equation, while a convenient nomogram has been developed by Davis [19, 1932].

The Pensky Martens tester (Fig. 7) is standardized in Great Britain and in the U.S.A. for determinations of closed flash-points above 120° F (in G.B.) and above 175° F (in U.S.A.) under I.P.T. Serial Designation GO 7, and under A.S.T.M. Designation D 93-22. The apparatus is also used in Germany and is standard in Italy. The instrument consists essentially of an oil cup supported in a cast-iron bath which may be gas or electrically heated. The oil-cup cover is fitted with thermometer, stirrer, and a shutter device analogous to that of the Abel apparatus

Two thermometers are supplied with the instrument, for use at temperatures above or below 220° F. The temperature is raised at the rate of 10° F per min., the test-flame being applied every 2° below 220° F and every 5° above this temperature.

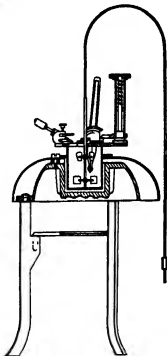

FIG. 7 Pensky Martens flash-point apparatus

The Luchoire Closed Flash Point tester has been standardized in France under Designation A.F.N.O.R. B 6-24, although it is recommended that the open-cup method be used for lubricating oils. The oil cup is closed by a cover with a short chimney and with two apertures to admit air. The test flame is placed in position above the top of the chimney, and the temperature noted when a slight explosion occurs in the cup above the oil.

The open flash-point determination is more widely used for testing lubricants than the closed flash-point. Several designs of apparatus have been standardized for this purpose in different countries.

In Great Britain a modification of the Pensky Martens is standardized under I.P.T. Serial Designation L.O. 7a. The oil-cup cover is replaced by a simple cup carrying thermometer and test flame, the latter being fixed centrally above the oil surface, level with the rim of the cup. The open flash- and fire-points are usually carried out on the sample used for the closed flash-point, the temperature being raised 10° F per min. till a flash appears on the surface of the oil (open flash) and then till the oil vapours burn for 5 sec (fire-point).

In the U.S.A. the Cleveland Open Cup method has been adopted under A.S.T.M. Designation D 92-33. The oil is contained in a shallow brass cup, supported in a metal plate and directly heated (by gas or electrically). The thermometer is suspended in the oil, which is heated at the rate of 10° F. per min., and the test flame is applied every 5° so that it passes diametrically across the oil surface. A modified form of the Cleveland tester is standardized in France under A.F.N.O.R. B 6-24.

In Germany the Marcusson Open Cup instrument has

recently been standardized under the specification D V M 3,661. The porcelain oil cup is supported in a sand bath and has two filling lines engraved on it, the lower one for oils flashing below 250° C. The thermometer is suspended in the oil, while the test flame is arranged so that it can be brought to the centre of the rim of the cup. Heat is applied by a gas burner so that the temperature is rising by 3° C per min. when approaching the flash-point, and the test flame is then applied for 1 sec. every degree rise in temperature.

Analytical Distillation

Although the distillation analysis of lubricating oils is of no such importance as that of the lighter distillates, nevertheless increasing attention is being paid to vacuum distillation methods, particularly in the examination of internal-combustion engine lubricants, and in the correlation of lubricating-oil characteristics with performance. The data obtained can give information on the presence of heavy residuals (bright stock), as in the determination of the carbon-forming tendency (see under 'Carbon Residue'), and of lighter fractions, such as are present in used crankcase lubricating oils (see 'Crankcase Dilution'). In conjunction with the viscosity and specific gravity, the distillation curve is of value in deciding upon the origin and character of a lubricating-oil fraction, particularly when corresponding data on oils of known characteristics are available.

Vacuum distillation methods used for this purpose fall into two classes, simple distillation with no attempt at fractionation, comparable with the Engler method for light spirits, and those utilizing an efficient fractionating column with controlled reflux, comparable with the 'true boiling-point' column (see sect 25). The pressures employed range from 40 or 50 mm. of mercury down to below 0.1 mm., a McLeod gauge being necessary for measurement of these lower pressures (the errors inherent in the measurement of low distillation pressures have been discussed by Hickman and Weyerts [51, 1930]).

The distillation results may be expressed in the form of a distillation curve, comparable with that for gasolines. A convenient procedure is to convert the vapour temperatures obtained into those corresponding to a pressure of 760 mm., by use of the Ramsay-Young equation, from the empirical formula and table of constants given by Ashworth [3, 1924], or by use of the nomographs developed by Watson and others [106, 1935]. Distillations carried out under differing conditions of pressure are then comparable with one another, while the necessity of maintaining a uniform pressure during the distillation does not arise.

The U S Bureau of Mines method for vacuum distillation has been widely used [20, 1922]. A 300-ml Hempel flask (A S T M Designation D 285-33) is fitted with a vertical air-condenser leading to a graduated cylinder with side arm for evacuation purposes. 150 ml of oil is distilled at a pressure of 40 mm., maintained constant by an air leak or an automatic control, to a maximum vapour temperature of 300° C., heat being applied by an electrical heater. A modified Bruhl receiver is used when necessary to collect and examine the fractions separately. An interesting modification designed by Peterkin and Ferns [77, 1925] utilizes direct gas heating. 100 ml of oil is distilled at 10 mm., the pressure being maintained constant by an automatic regulator of very simple design. An apparatus of more elaborate design, for use at pressures down to 0.1 mm., has been described by Watson and Wirth

[106, 1935] (see Davis and Hornberg [18, 1933], Lous [64, 1933]).

The design of satisfactory laboratory fractionating equipment for vacuum distillation is a matter of some difficulty, particularly in obtaining a satisfactory control of reflux. For details reference should be made to papers by Guthrie and Higgins [42, 1932], in which the apparatus in use at the U S Bureau of Mines is fully discussed, and Beswenger and Child [8, 1930].

An analytical steam-distillation method, yielding results analogous to those from vacuum distillation, has recently been developed by Saal and Verver [87, 1933].

Volatility Tests

The complete volatility characteristics of an oil are obtained from its distillation curve (loc cit). The commonly used type of volatility test, in which the oil is heated under predetermined conditions and the loss in weight determined, serves only as an indication of the content of more volatile constituents and cannot adequately replace a distillation test. Moreover, unless air is excluded, such tests tend to approximate to the character of an oxidation test.

Archbutt's Vaporimeter [2, 1927] has been used in studies of the carbonization tendency of lubricants [23, 1927]. The oil is heated in a small platinum dish supported in a combustion tube through which passes a stream of pre-heated steam or other gas.

The standard volatility test for transformer and other oils is described under I P T Serial Designation T O 17. The oil is heated in a small beaker embedded in lead shot contained in a toluene vapour bath. The loss in weight of the oil after 5 hours' heating in air is determined. The Air Oven method used for asphaltic bitumens (I P T Serial Designation A 17, A S T M Designation D 6-27) has also been used for the evaluation of lubricants [17, 1931].

Demulsibility

Oil and water normally tend to separate out rapidly from their mixture upon standing. The stability of the emulsion produced depends upon several factors: the interfacial tension between the oil and water, which may be profoundly modified by traces of acids, soaps, and electrolytes, the presence of a third phase such as finely divided carbon on which adsorption may occur, the temperature, and the degree of emulsification. The relationship between surface tension and stability of oil emulsions has been discussed by Dimmig [22, 1923] and by Hemmer [48, 1932] (cf. Clayton [16, 1928]). In the case of certain steam-cylinder oils and soluble cutting lubricants the formation of stable emulsions with water may be desirable, but for other purposes, as in steam-turbine lubricants, this can be very detrimental. It is then necessary to select an oil which shows rapid demulsification, as exhibited by a stable, well-refined, pure mineral oil of moderate viscosity.

For the evaluation of steam-turbine oils, various demulsification tests have been devised which determine the rapidity of separation of an emulsion of oil and water (or other aqueous solution). In general these tests do not seek to duplicate the conditions present in actual practice, but serve to evaluate the demulsification ability of an oil under certain arbitrary conditions. The most widely used of these is the modified Conradson steam-blowing test—the Demulsification Number test (A S T M Designation D. 157-36, and I P T Serial Designation L O. 16 (Fig. 8).

The Steam Emulsion Number (in seconds—A S T M) or the Demulsification Number (in minutes—I P T) is the time required for an oil to separate when emulsified and allowed to separate under definitely prescribed conditions. A steam generator is arranged to blow dry steam through a 20-ml sample of the oil contained in a 50-ml graduated tube, surrounded by a water bath at 70° F. Steam is passed so that the oil is maintained at 190° F until its volume has increased to 40 ml. The tube is then transferred to a separating bath at 200° F and the time of separation of 20 ml of oil observed (to a maximum of 20 min). The time taken—in minutes I P T, or seconds A S T M—is then reported as the Demulsification Number or steam Emulsion Number of the oil. This test does not, unfortunately, distinguish between the varying degrees of sharpness in the separation of emulsions obtained with different oils. In some laboratories it is preferred to report the demulsification results graphically and to describe the nature of the emulsified and separated layers.

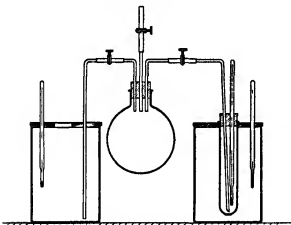

FIG 8 Demulsification apparatus (I P T and A S T M)

In the German Richtlinien method (*Richtlinien*, 6th ed, p 100) steam is passed into a graduated cylinder containing 100 cc of oil and 50 cc of water for 10 min. The mixture is allowed to separate for 10 min at 100° C and a further 60 min at room temperature, on examination the oil is described as non-emulsifying if the oil and water show a clean separation, as feebly emulsifying if a layer of emulsion not more than 2 mm in depth remains, and as emulsifying if a greater amount is present. A variation in this method is that of the A G Brown, Boveri Company, who use calibrated steam injector jets and express the separation of the emulsion by a demulsification graph (Holde [55, 1933]).

The Herschel Demulsibility method was formerly standard in the USA until the adoption of the more reproducible Conradson procedure. In this method 27 ml of oil and 53 ml of water, contained in a 100-ml cylinder, at a temperature of 130 or 180° F, are stirred by a motor-driven paddle for 5 min. The mixture is then allowed to separate and the rate of settling observed every minute, the maximum rate found, expressed in milliliters per hour, is termed the Demulsibility of the oil (*U S Bur of Mines Bull* 323 b, 320-31, 320-41 (1927)).

The British Admiralty Demulsification test is of a very severe character and is applied to oils intended to pass the Admiralty Specifications for turbine oils. The oil and water (1:2 by volume) are emulsified for 1 hr in a water-

jacketed vessel at 160° F, by means of a motor-driven stirrer and circulation pump (800 r p m). A sample is removed and held at 100° F for 15 min, when 95 ml of this sample is centrifuged at 1,500 r p m for 15 min. At least 96% oil must be shown, the remainder containing at least 50% clear water.

The demulsification of a pure well-refined mineral oil is usually very good, below 5 min by the Steam Emulsification method, but the presence of asphaltic material, organic acids, and metallic soaps tends to stabilize the emulsion to a marked degree. Consequently the demulsibility may be considered in conjunction with an artificial ageing test, such as is used for transformer oils. Reference should be made to papers by Salomon [89, 1931] for a very full discussion of these factors.

For steam-turbine lubricating oils the demulsification test is considered, next to the viscosity, the most important for specification. For oils intended for other purposes there is no uniformity of opinion as to the practical value of this test, and while it is sometimes included in specifications for such oils it may, in general, be considered unnecessary.

Emulsification Tests.

As previously observed it is desirable that certain oils, such as soluble cutting oils, should form stable aqueous emulsions. The U S Federal Specifications Board detail an emulsifying test under Method 320-5, in which 95 ml of water and 5 ml of oil are shaken for 1 min, when no separation should occur after 1 hr standing.

For some steam-cylinder oils (compounded) emulsifying properties are also required and an emulsion test is specified under Methods 320-11 and 320-21, using the Herschel apparatus. The emulsion with water and with 1% salt solution should remain stable for 1 hr. The value of such a test, however, is open to doubt.

Carbon Residue

The formation of carbon deposits in air compressors and in internal-combustion engine cylinders is due chiefly to the evaporation, cracking, and subsequent carbonization of traces of lubricating oil which have leaked past the piston rings into the cylinder head [75, 1925, 99, 1930]. This deposit varies according to the type and condition of the engine and the lubricating oil employed. Other factors being equal, it is desirable to select an oil producing the least carbon deposit, and for this purpose laboratory carbonization tests have been devised in which the oil is destructively distilled and the residue measured. The most widely used of these testing methods is that due to Conradson, modified to yield a higher degree of reproducibility.

Conradson Carbon-residue Test.

This is standardized under A S T M Designation D 189-36 and I P T Serial Designation L O 9, and has been widely adopted in other countries. Ten grams of the oil are placed in a weighed porcelain crucible contained in a larger Skidmore cast-iron crucible with lid and air vent. This, in turn, is placed in a large sheet-iron crucible, supported on a tripod and surrounded by a shield and chimney (Fig 9). Heat is applied by a Meker burner so that smoking is observed in approximately 10 min. The oil vapours are ignited and should continue burning for a further 13 min. After finally heating for 7 min, the residue is weighed and reported as percentage carbon residue.

(Conradson) The results should duplicate to within 10% of the mean value, and greater divergences can generally be attributed to incorrect control during the heating periods. The residue so obtained is occasionally subjected to ignition for subsequent determination of the ash content of the oil, but this procedure is not to be recommended.

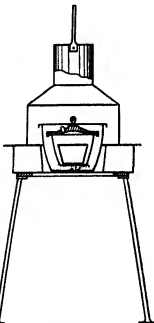

FIG 9 Conradson carbon-residue apparatus

Ramsbottom Coking Test.

This method, widely used in Great Britain, has been standardized under IPT Serial Designation LO 9a, as an alternative to the Conradson test, and is included in the British Air Ministry specification for Aircraft lubricating oils. Approximately 4 g of the oil are contained in a small cylindrical glass bulb with a short capillary neck. The bulb is heated by introduction into an iron sheath immersed in molten solder at 500° C. After complete volatilization of the oil, the residue is weighed and expressed as percentage carbon residue (Ramsbottom). The procedure has been critically examined by Kelly [39, 1929] who has introduced refinements leading to a higher degree of precision (to within 5% of the mean value).

The Ramsbottom method yields more reproducible results than the Conradson, due chiefly to the better temperature control, but their relative merits are open to discussion. The carbon residues from the two methods are not directly comparable, but for a given series of oils the results determined by the two methods normally lie in the same order of merit [27, 1933, 79, 1933].

The carbon residue of an oil depends on several factors. Pure paraffins and naphthenes, unless of very high molecular weight, yield small carbon residues, the major portion of this residue from an oil being formed from the asphaltic and so-called unsaturated constituents, and from those constituents of high molecular weight and boiling-point. The carbon residue, therefore, decreases with increasing degree of refining, in line with the diminution in colour, asphaltenes, and sulphuric acid soluble components, and is negligibly small in the case of purified wax and oleum-treated paraffin. For a given degree of refining the carbon

residue increases with decrease in the volatility and reaches its highest figure in the heavy residuals and bright stocks (over 1% compared with less than 0.1% for distillate oils). For most commercial oils the carbon residue is an indication of the overall volatility of the oil, and has little relation to the viscosity or gravity except in unblended oils of known origin.

Correlation with Engine Deposits of Carbon.

The carbon residue of an internal-combustion engine lubricating oil increased during service, partly from sludge deposition and partly from changes in the oil itself. Since the engine carbon deposits are formed largely from this 'used' oil, it would appear better to evaluate the oil on the basis of its carbon residue together with that on the oil after a suitable ageing or oxidation test. This procedure is adopted in the British Air Ministry specification for aircraft lubricating oils.

An approximately linear relationship between Conradson carbon residue and coke deposition in service has been found to exist by Livingstone, Marley, and Gruse [63, 1926-7, 1929], and is further supported by the work of Haslam and Bauer [46, 1931], and Philippovich [79, 1933]. Other investigators have preferred to express the carbon-forming tendency of an oil by some form of distillation test in which the amount of high-boiling components in the oil is determined. Bahlke, Barnard, Esenger, and FitzSimmons have utilized a volatility index given by the 90% distillation temperature of the oil under 1 ml pressure [5, 1931]. Livingstone [73, 1926-7, 1929] has used an analogous method for predicting carbon deposition in sleeve-valve engined commercial vehicles.

The carbon-residue test does not indicate the character of the carbon deposits formed in the engine cylinder. No differentiation is made between the soft 'fluffy' deposits from naphthene-base oils, which may be partially ejected through the exhaust during engine running, and the harder, more tenacious deposit from paraffin-base oils. The use of the test as the major criterion of an oil for internal-combustion engines is to be avoided. Low-grade distillate oils of low stability, for example, will usually possess considerably lower carbon residues than paraffin-base oils of greater suitability.

Oxidation Testing Methods

In engineering practice, particularly with internal-combustion engines, reciprocating steam engines, and steam turbines, the lubricating oil may be subjected to relatively high temperatures in the presence of air and catalytically active metals or metallic compounds. The resultant oxidation of the oil leads to the development of acidity and the formation of sludge and, especially at higher temperatures, of gummy deposits. The acids so produced are, in many cases, definitely corrosive, while the deposition of sludge may lead to lubrication failure, either through stoppage of oilways, or through direct interference with the oil film between the bearing surfaces. The development both of acidity and of sludge is especially detrimental in steam-turbine lubrication, where the lubricant must display a high degree of demulsification.

Although the mechanism of oxidation is extremely complex, it appears that the unsaturated and asphaltic constituents yield a sludge of asphaltenes, while the pure paraffins and naphthenes tend to form acidic products, partly volatile, which may polymerize further to asphaltenes and also combine with metals present to give a sludge of

metallic soaps. In addition carbon from combustion-chamber blow-back, abraded metallic particles, road dust, and condensed water may be present and yield a very coherent and troublesome deposit.

The ability of automotive and other lubricating oils, working under severe conditions, to withstand these deleterious changes is of the utmost importance, and numerous laboratory oxidation tests have been evolved to measure the relative oxidation characteristics of lubricating oils. Accelerated conditions may be produced by high temperature, pressure, and catalytic action. The influence of temperature varies with different oils, and such oils may be evaluated in a differing order of merit according to the arbitrary temperature chosen, the latter should, therefore, approximate to that in actual practice. The presence of catalytic materials introduces a rather indeterminate factor and is usually avoided, although used in some transformer-oil testing methods.

The oxidation-testing methods available may be classified as static methods, in which the oil is heated in air or oxygen at atmospheric pressure, bomb methods using elevated pressures, and dynamic methods in which air or oxygen is blown through the oil.

The progress of oxidation may be followed in several ways by observation of the oxygen absorption, or of the increase in viscosity, specific gravity, carbon residue, asphaltene content, acid value, or saponification value. These factors are to some extent interdependent, but do not usually show parallelism over the period of oxidation. A pronounced induction period, varying with the oil and the particular characteristic under investigation, is shown by many oils. The absorption of oxygen provides the most exact method for following the progress of oxidation, but its determination presents some difficulty, while its correlation with service changes in lubricants is not definite. For correlation with engine sludging, determination of the asphaltenes formed appears most applicable and has been generally adopted. The development of acidity has been used by Hackford, while the increase in viscosity and carbon residue are included in the British Air Ministry test. In the U.S. Bureau of Standards' 'stability number' and in the U.S. Navy 'Work Factor' method the alteration in all four characteristics is taken into consideration.

The majority of testing methods involve oxidation over a fixed period of time. A better description of the behaviour of an oil is obtained by following the progress of deterioration over a prolonged period, and this procedure has been adopted in the 'Life' tests for transformer oils and in the Indiana test. The lengthy time required to complete such tests militates against their more general adoption.

Static Oxidation Tests.

The Sligh Oxidation Test [92, 1925] has been widely used in the United States. The standardization of this test has been under consideration by the American Society for Testing Materials and the proposed method is fully described in the Proceedings [15, 1927]. Ten grams of the oil, contained in a stoppered conical flask of special design, from which the air has been displaced by oxygen, is maintained at 200° C in an oil bath for 2.5 hr. The number of milligrams of asphaltenes formed, determined by solution of the oil in petroleum spirit and filtration through a Gooch crucible, is termed the Oxidation Number of the oil.

In the Waters Test [105, 1921], described in U.S. Bureau of Standards Circular no. 99, 10 g. of the oil are heated

at 250° C for 2 hr. in a 150-ml conical flask, and the increase in asphaltenes determined. Similar open-cup methods have been used by Garner [38, 1921], Hoblyn [53, 1925], and others.

Oxidation Tests under Pressure.

Comparatively little use has been made of this procedure although eminently suitable for measurement of the oxygen absorption. Butkov [13, 1927] has used a bomb method for transformer and turbine oils, involving oxidation at 14 atm and 150° C for 5 hr, with measurement of oxygen absorption or of sludge formation. The method has been applied by Chernozhukov [14, 1929] to the evaluation of aeroplane and automotive lubricants.

Dynamic Methods.

These comprise the majority of oxidation tests devised for transformer, insulation, and lubricating oils.

The British Air Ministry Oxidation Test (Specification no. DTD 109), although introduced as a specification test for aircraft oils, has been widely used for the evaluation and comparison of internal-combustion engine oils generally. The apparatus and procedure for the test have recently been discussed very fully by Garner, Kelly, and Taylor [39, 1933]. Forty millilitres of the oil is contained in a wide boiling tube immersed in an oil bath at 200° C ($\pm 0.1^\circ$ C) and air is blown through the oil at the rate of 16 litres per hour for two consecutive periods of 6 hr. The viscosity at 100° F and the Ramsbottom carbon residue are determined on the original and oxidized oils. According to the Air Ministry Specification, the viscosity should not have increased to more than twice its original value, nor the carbon residue more than 1%.

The Hackford Factor [45, 1926] is based on the increase in acidity during oxidation. The lubricating oil is subjected to a stream of oxygen for 9 hr at 150° C, the increase in acidity expressed as millilitres of decinormal potassium hydroxide per 10 g. of oil is termed the Hackford Factor.

In the Indiana Oxidation Test, introduced by the Standard Oil Company of Indiana [6, 1934], 300 ml of the oil in a Pyrex boiling tube is maintained at 342° F in an oil bath while air is blown through at 10 litres per hour. Periodically 25 ml of the oil is removed and the asphaltenes determined on a 10-g. sample. The Sludging Time—the number of hours for the formation of 10 mg of asphaltenes per 10 g. of oil—is recorded. A sludging time of 70 hr or over is considered to represent a very satisfactory degree of stability for motor oils. The determination of the time for the formation of 100 mg of asphaltenes will furnish additional information on the oxidation characteristics of an oil, while in the case of very stable lubricants, with sludging times of more than 50 hr, the determination of the change in viscosity is advocated.

Guthrie, Higgins, and Morgan [43, 1934] at the U.S. Bureau of Standards have developed an oxidation test, similar to the Air Ministry method, in which the changes in viscosity, carbon residue, precipitation number (asphaltenes), and neutralization number are determined and the resultant factor averaged to give a general stability number for the oil. This is found to be directly proportional to the duration of the test and can be linearly related to the temperature on suitable co-ordinates. Use has also been made of transformer oil sludging tests (p. 1445) for the evaluation of lubricants, particularly in the case of Turbine lubricants in which very high resistance sludge formation

is necessary. The Michie sludging test is specified for steam-turbine oils in British Standards Specification B S S no 489, 1933. In Germany the standard 'Tar Formation Number' test, evolved for transformer oils, has been used for the evaluation of lubricating oils [55, 1933]. Essentially, 150 g of the oil are heated in a conical flask for 70 hr at 120° C, under an oxygen stream of two bubbles per second. The increase in Tar Number (see later) and in benzene insoluble sludge, after oxidation, are then determined.

The oxidation characteristics of lubricating oils vary widely according to the origin and type of the oil and the refining procedure adopted. Paraffin-base oils are well known for their satisfactory behaviour, as are certain naphthene-base (Russian) lubricants. Some residual oils (Pennsylvanian bright stock, for example) exhibit better oxidation stability than corresponding distillates, attributed by some to inhibiting constituents present in the residual fractions. Refining treatment, by removing the least stable components, improves the resistance to oxidation of an oil, although excessive acid treatment not infrequently lowers this factor. Solvent refining with selective solvents is noteworthy for its effect in improving the oxidation stability. The inhibiting and accelerating effects of traces of certain compounds (both organic and metallic) upon oxidation stability are very marked, and lubricating oils which contain compounds of lead and tin, for improving their stability, are available commercially.

Correlation with Performance.

From the standpoint of internal-combustion engine lubrication laboratory oxidation-testing methods should in general be considered in relation to the deterioration of the crankcase lubricating oil. The production of sludge, with the resultant possibility of lubrication failure, and the gumming of piston-rings in their grooves—of extreme importance in high-duty aircraft engines—is essentially due to the oxidation and general thermal decomposition of the lubricating oil. Carbon deposition in the combustion chamber, on the other hand, is more particularly related to the volatility characteristics of the oil although oxidation is undoubtedly a contributory factor.

Although some investigators have concluded that laboratory oxidation tests are of no practical importance for predicting the behaviour of an oil in the engine [67, 1927, 99, 1930], others have obtained better correlation, and the general consensus of opinion is strongly in favour of the inclusion of some form of oxidation test for such lubricating oils. Hoblyn [53, 1925] has shown that oils of poor engine-sludging characteristics have high Michie sludge values and show microscopic evidence of early decomposition when heated at 250° C in an open cup, while close correlation between the properties of oils after a 5-hr sludging test at 170° C, and after extended service in automobile engines has been obtained by Ehlers [24, 1930, 1932]. The British Air Ministry test is widely used in Great Britain for the comparison and evaluation of both automobile and aircraft oils, and is considered to be an excellent criterion in several laboratories. The Indiana oxidation test is stated to give very good correlation with the sludge formation in standard automobile engines. This test is in wide use in the United States and, although requiring an inconveniently long time, enables the progress of deterioration to be followed closely, and probably affords better comparison of oils of widely differing oxidation characteristics than short-period tests.

At present, however, it cannot be said that any of the methods developed have been correlated with service behaviour under the widely varying conditions possible, and with the range of lubricants available, to such a degree as to make possible any satisfactory agreement on a standardized test.

Unsaturated and Reactive Constituents

The presence of unsaturated and reactive constituents in a lubricating oil renders it unstable to heat and oxidation, causing sludge deposition under service conditions. These components are preferentially attacked by chemical reagents (the basis of chemical-refining methods), and the reactivity of an oil towards such reagents as sulphuric acid, halogens, and bleaching earths is therefore some measure of its stability and degree of refining.

With the present development of refining methods, lubricating oils containing appreciable proportions of unstable constituents are now rarely marketed, and methods of test for such impurities are used to a very much smaller extent than formerly. The significance of these tests, and their value in specifications, is very questionable, and if it is necessary to obtain a comparative figure for the stability of lubricating oils this is best determined by some form of oxidation test.

Sulphuric Acid Absorption

The action of sulphuric acid upon lubricating oils is discussed elsewhere. The degree of reaction may be estimated from the amount of oil adsorbed by the acid, or, in the case of refined oils, some indication may be afforded by the colour produced in the acid layer. The sulphuric acid absorption number is dependent on the strength and relative volume of the acid, and the temperature and time of treatment. The comparatively high viscosity of lubricating oils necessitates centrifugal separation, unless the oil is diluted with a petroleum spirit prior to the acid treatment. Such tests, from their arbitrary nature and doubtful significance, are no longer standardized, but still find a place in research and in refinery control work.

For the determination of unsaturates in Transformer oils, the method formerly standardized by the U S Bureau of Mines (Technical Paper 323 A, 1924) comprised treatment of 15 ml of the oil with 10 ml of sulphuric acid (sp gr 1.84) at 0° C. The percentage decrease in volume after centrifuging was reported as unsaturates. A modification of the method used by Ford [34, 1927] was stated to give some correlation with sludging characteristics. Walther [104, 1929] has described a simple acid test in which equal volumes of oil, benzene, and 50% sulphuric acid are shaken together, giving a qualitative indication of the degree of refining and ageing characteristics of the oil.

The Tar Number.

For determining the resinifying tendency of Turbine oils, Kissling introduced the Tar Number test, a modification of which has been adopted in Germany for testing Transformer oils, generally in conjunction with an ageing test. Fifty millilitres of the oil is heated under reflux with an equal volume of alcoholic sodium hydroxide solution for 20 min. After shaking and cooling, the alcoholic layer is separated off, 40 ml of it neutralized and the liberated tar extracted with benzene. The weight of tar obtained by drying at 105° C, multiplied by 2.5, is the Tar Number of the oil (Holde [54, 1933], p 263). The test is of no value in the case of lubricants containing fatty oil.

Iodine and Bromine Values.

The action of halogens on hydrocarbons of high molecular weight is more complex than in the case of light distillates. Examination by the Mellinney method (p 1398) points to the predominant reaction as one of substitution with small direct addition of halogen [58, 1922]. The latter may, however, be due to the instability of the higher halogenated molecules which tend readily to split off hydrogen-halide with production of a comparatively stable hydrocarbon residue of doubtful constitution. Iodine and bromine values determined on heavy mineral oils are found to vary widely with the conditions of the method, particularly with the relative concentrations of oil and halogen. The results obtained under a given set of conditions are so arbitrary and their significance with regard to the general stability of the oil is so questionable (cf Heyden and Tytko [50, 1927]) that such methods have found very little application.

In addition to the methods described under *Gasoline*, Bacon [4, 1928] has described a modification of the Francis method which is applicable to lubricating and other heavy oils. Galle and Bohm [37, 1932] have used a shortened modification of the Hubl method for lubricating oils, in which the oil is dissolved in a mixture of amyl and ethyl alcohols and treated with an excess alcoholic iodine solution in the presence of water.

Estimation of Resins

It is possible to extract and thus to estimate the more reactive constituents of an oil by physical means. Liquid sulphur dioxide and other selective solvents, for example, will effect a partial separation, the extract being considerably richer in unsaturated constituents than the raffinate.

By treatment of a petroleum ether solution of the oil with active charcoal, silica gel, fuller's earth, or other bleaching clay, the unsaturated resinous constituents are preferentially adsorbed. The charcoal or earth may be washed free of oil with petroleum ether and the adsorbed material removed to a considerable extent by washing out with chloroform or benzene (Garner [38, 1921], Sachanen and Vassiliev [88, 1927]).

Asphalt Content

The term 'hard asphalt' (asphalt, or asphaltenes) is applied to those constituents of an oil precipitated by cold, light petroleum spirit. The asphalt content is an arbitrary figure dependent upon the relative amount and characteristics of the petroleum spirit used and on the procedure adopted for the separation. For adoption as a standard test, therefore, it is essential that the procedure and reagents used are carefully standardized. The physical and chemical characteristics of the spirit are of considerable importance: the lower boiling components precipitate most asphalt, while cyclic, and particularly aromatic, compounds show a rather pronounced solvent action. It is therefore necessary that the spirit used shall be of specified boiling range, free from aromatics, and shall have a low naphthene content (see Evans [26, 1923]).

In the method for determination of asphaltenes in oils, standardized under I P T Serial Designation F O 12, not more than 10 g of the oil are dissolved in petroleum spirit of specified properties (the number of millilitres of spirit used is 10 times the weight of oil in grams). After standing 24 hr in the dark, the solution is filtered, the residue washed, dissolved in benzene, and evaporated off

to constant weight, the asphalt being reported as a percentage. The method has received some criticism on account of the co-precipitation of hard wax, if present, and some authorities prefer the following method due to Holde. In this, the German standard method (D V M 3,660), the precipitate from Kahlbaum's 'normal' benzene is Soxhlet-extracted with the benzene to remove waxy material. The asphalt is then extracted with benzene as in the former method, and may be further examined by treatment with benzene and alcohol respectively. In order to reduce the tedious filtration and washing of the precipitated asphalt, Gooch and sintered-glass crucibles, with filter-pads of asbestos or glass powder, are used in several laboratories (see, for example, Müller [74, 1932]).

The 'precipitation number' test, based on the volume of precipitated asphaltenes determined by centrifuging, is widely used in the United States and is described under A S T M Designation D 91-35. Ten millilitres of the oil are dissolved in 90 ml of standardized petroleum spirit and, after standing at 90° F, centrifuged for 10 min., the procedure being repeated until the sediment is of constant volume. This volume (to 0.1 ml) is reported as the A S T M Precipitation Number. A gravimetric method is under consideration.

The use of other solvents leads to precipitation of asphaltenes and resinous substances of differing characteristics (cf Gurwitsch [41, 1932]). Marcussen [66, 1927] recommends precipitation by ethereal ferric chloride solution for the rapid estimation of hard asphalt, while in some laboratories the use of di-ethyl ether is preferred to that of petroleum spirit on account of difficulties in the standardization of the latter precipitant. Alcohol-ether mixture, butyl and higher alcohols, and esters precipitate a softer variety of asphalt, the first-named solvent being used in the estimation of soft asphalt in bitumen (I P T Serial Designation A 13). The value of such tests for lubricating oils is open to considerable doubt.

The presence of asphaltenes in lubricating oils is an indication both of the refining treatment accorded to the oil and of the type of parent crude. Distillate oils should contain no asphalt, any produced during the distillation, through overheating, oxidation, or the general instability of the oil being removed by acid refining and earth filtration. Residual oils may have but little asphalt, as in paraffin-base oils, which can readily be removed during refining, or may consist almost entirely of asphaltic material in the case of some asphalt-base crudes. For internal-combustion engine lubricating oils the presence of asphalt leads to increased coke and sludge deposition, although in itself it is no criterion of the carbonizing or sludging characteristics of the oil, and is particularly undesirable in the case of steam-turbine oils, causing severe emulsification and sludge formation. Black steam-cylinder oils contain appreciable quantities of asphaltenes, but these are largely removed in filtered oils and bright stock. In certain types of lubricants for rough uses a high asphalt content is no defect.

The determination of hard asphalt has found extensive application in following the deterioration of lubricating oils under service conditions and under accelerated ageing tests, asphalt formation in general running parallel with the oxidation and deterioration of the oil.

Paraffin Wax

The wax content of lubricating oils is usually very small, due to the efficiency of modern dewaxing practice. The effect of wax in an oil is considerably to raise the pour-

point, the elevation being proportional to the wax addition, and thereby cause interference with lubrication under low-temperature conditions. Actual determination of the wax content is rarely necessary, the pour-point and cloud-point supplying sufficient information for most purposes.

Wax in a lubricating oil is determined by a modification of Holde's procedure, depending on its precipitation at low temperature from an ethereal solution on addition of alcohol. The method standardized under I P T Serial Designation C P 31 for determination of wax in crude oil is applicable to lubricating oils. Sufficient oil (free from asphalt) to yield 0.05-0.1 g. of wax is dissolved in a mixture of equal volumes of ether and 96% alcohol. After cooling to -20°C . the precipitated wax is filtered off, dissolved in hot acetone, re-precipitated by cooling, and washed free of oil. The residue of wax is taken up in petroleum ether and dried to constant weight. The use of acetone [113, 1925] facilitates the removal of adherent oil from the wax, eliminating the tedious washing with alcohol-ether (cf. Cross [17, 1931], p. 694), butanone [55, 1933] may also be used for this purpose.

Acidity

Acidic substances present in lubricating oils may be of inorganic or organic character. Inorganic acidity is due either to contamination of the oil or to inefficient refining technique whereby acid (i.e. sulphuric acid) used in refining has been incompletely removed, traces of alkali may similarly be left in the oil. Free mineral acid is extremely corrosive, no reputable lubricating oil would contain any trace of this or of free alkali, and its determination constitutes therefore an important refinery control test. Inorganic acid may be formed in an oil during use in internal-combustion engines by contamination with the products of combustion of sulphur compounds in the fuel [21, 1928, 72, 1927].

The presence of organic acidity may be due to a variety of factors. The complete removal of naphthenic acids from the lubricating-oil fractions of certain crudes is a matter of difficulty, but the small acidity which may remain in the finished oil appears to have no harmful effect. Fatty acids may be present in blended lubricants (i.e. containing fatty oils) and can be further developed under hydrolysing conditions. Such acidity may, according to Archbutt and Deeley [2, 1927], produce corrosion, although the small amount of free fatty acids present in 'Germ Process' oils has been stated to have no corrosive action (Southcombe [93, 1932]). It is evident that the general quality of a lubricating oil cannot be evaluated from its organic acidity, and the permissible limits for this depend entirely upon the particular case of lubrication in question. Very low acidity appears necessary in the case of lubricants for steam turbines and for ball and roller bearings.

Organic acidity is also developed in mineral oils when exposed to oxidizing conditions over prolonged periods, such as may be encountered in internal-combustion engines and oil-cooled transformers (Harcford [44, 1926]). Determination of this acidity has therefore been used in following the deterioration of an oil in service or under accelerated oxidation tests.

The acidity of an oil is usually expressed as the number of milligrams of potassium hydroxide necessary to neutralize 1 g. of oil. Formerly the acidity was often reported in terms of oleic acid, sulphuric acid, or SO_3 , but this procedure is to be deprecated as unnecessary and potentially misleading.

Inorganic Acidity.

Inorganic acidity is generally considered to comprise the total water-soluble acids present. The methods for its determination consist essentially in the extraction of about 100 g. of the oil with an equal volume of hot water, separation of the water, and testing with methyl orange. If acid, it is titrated with decinormal alkali (I P T Serial Designation L O 5—Inorganic Acidity: A S T M Designation D 188-27 τ —Mineral Acid Neutralization Number and Alkali Neutralization Number). The A S T M procedure involves extraction of the oil with three successive portions of boiling water followed by titration with alkali or acid according to its reaction.

Total and Organic Acidity.

Since inorganic acidity is rarely present, the total acidity is usually organic, otherwise the organic acidity is obtained by subtraction of the inorganic from the total acidity found. The acids present are weak and practically insoluble in water, necessitating titration in alcoholic solution and furnishing a poor end-point.

In the method under I P T Serial Designation L O 5, not less than 10 g. of the oil are heated to boiling with 50 ml. of neutral 95% alcohol, boiled for 5 min., and titrated with decinormal potassium hydroxide and phenolphthalein after cooling to 50°C . A similar procedure is adopted under A S T M Designation D 188-27 τ (Neutralization Number), 50% alcohol being used except in the case of compounded oils, and the titration carried out in the hot solution. The use of a mixture of alcohol and benzene facilitates solution of the oil and its acid content and is specified in the French and German methods (A F N O R B 6-31, D V M 3,658). Although the use of neutral alcohol is generally specified, it may, in some cases, be desirable to carry out a blank titration on the solvent.

In the case of dark-coloured oils, detection of the colour change at the end-point is difficult, and several expedients have been used to facilitate this. Alkali blue indicator, standardized in the last-named methods, furnishes a more decided colour change, but is very sensitive to carbon dioxide. In the German method a special flask is used furnished with a side arm to facilitate observation of the colour change, while a spectroscopic method is suggested in the French procedure (Brüere Phthaleinoscope). For very dark oils it may be necessary to adopt Holde's procedure (Holde [55, 1933], p. 111) in which the alcoholic extract of the oil is separately titrated.

In order to eliminate the uncertainty of this method of titration, electrometric methods have been investigated, but at the present time have not reached the stage of standardization. The nature of the apparatus required would militate against their general adoption.

Evans and Davenport [28, 1931-6] compared the results obtained by use of the silver-silver chloride electrode with those from the normal A S T M method, using both phenolphthalein and alkali blue indicators, and found excellent agreement with the alkali blue method on solutions of organic acids. Ralston, Fellows, and Wyatt [81, 1932] have found the platinum-carbon electrode in isomyl alcohol satisfactory in the case of used lubricating and insulating oils, while the antimony electrode has been investigated by Vellinger and others [101, 1931, 1933]. The standardization of an electrometric method is under consideration by a sub-committee of the American Society for Testing Materials [31, 1931], and details of the proposed

method have been given in the A S T M *Standards on Petroleum Products and Lubricants*, 1936, p 25. The oil is dissolved in butyl alcohol and titrated with a standard solution of sodium butylate, using as indicator the quinhydrone electrode with a saturated calomel half-cell as a reference potential.

Separation of the Acids.

When necessary to isolate the organic acids for subsequent identification, they may be extracted from the oil with dilute alcoholic potassium hydroxide. The fatty acid soaps are then decomposed by acidification and the liberated acids extracted with ether (see under *Saponifiable Matter*).

Saponifiable Matter

The saponifiable matter in an oil or fat comprises those glycerides and other esters of fatty acids which are capable of being saponified, i.e. hydrolyzed and converted into soluble potassium soaps, by the action of potassium hydroxide under specified conditions. The saponification value, or saponification number, represents the number of milligrams of potassium hydroxide necessary to saponify completely the saponifiable matter present in 1 g of the material under investigation. Although theoretically a pure hydrocarbon oil has no saponification value, refined petroleum oils are occasionally found to have small values of the order of 4 or less, and considerably higher figures may be found in black asphaltic oils. Since, however, fatty oils have values in the neighbourhood of 200, depending upon the type of oil, the saponification value is, in general, an indication of the amount of fatty oil present. The actual percentage of fatty material can only be calculated from this figure when the saponification value of the fat is known, otherwise it is necessary to isolate and weigh the fatty acids from a sample of the oil and thence calculate the corresponding amount of fatty material present.

The saponification value may, in addition, be used for following the progress of deterioration of an oil in service or under an accelerated ageing test, since organic acids and saponifiable substances are formed in petroleum oils under oxidizing conditions.

Approximate Saponification Values of Fatty Oils

Arachis oil	190	Tallow	195
Castor oil	180	Sperm oil	130
Olive oil	190	Shark liver oil	163
Rape oil	175	Whale oil	193
Lard oil	195	Coco-nut oil (deodorized)	260

Determination of Saponification Value.

The saponification value of an oil is usually understood to include any free fatty acids as well as neutral glycerides and esters. The French 'saponification index', however, refers only to neutral fats, any free acidity being corrected for. The essential feature of the methods used for determination of the saponification value is saponification of the oil by heating with a definite volume of alcoholic potash solution, followed by titration of the unused alkali with standard acid. The difference between this and the titration of a blank, run on the alcoholic potash alone, gives the amount of potash used in saponifying the oil.

In the method tentatively standardized under I P T Serial Designation L O 5 (r), not more than 10 g of the oil (depending on its saponification value) is refluxed for 3 hr. with 25 ml of semi-normal alcoholic potassium

hydroxide, followed by titration in the cold with standard hydrochloric acid. A similar procedure is detailed under A S T M Designation D 94-36, the titration being carried out in the hot liquid.

Heavy oils may cause trouble through mechanical retention of alkali and through their low solubility in alcohol. The use of a solvent to promote more intimate contact of oil and alkali has been suggested, the addition of petroleum ether in the case of cylinder oils being recommended in the last method. In both the French and German methods (A F N O R B 6-29, D V M 659) the addition of benzene is specified, and alkali blue indicator is used to produce a sharper end-point. An interesting rapid method is included in the French procedure, utilizing xylene with a solution of potash in *n*-propyl alcohol for the saponification.

When certain waxes and esters are present, the normal procedure may be insufficient for complete saponification, and in such a case it is necessary to make use of more concentrated potash solution, longer heating, or higher temperature and pressure to obtain complete saponification (cf. Braun and Claffey [12a, 1936]).

Determination of the Percentage of Fatty Material.

If the saponification value of the fatty material is known, its percentage can readily be calculated by simple proportion from the saponification value of the oil.

For samples of unknown constitution, although assumption of a mean value of 195 will give an approximate figure, an accurate determination of the saponifiable matter necessitates a gravimetric estimation. The procedure is to extract the alkali soaps from the saponified mixture with alcohol, to liberate the free acids by acidification of the soaps, and then to separate and estimate these free acids. The equivalent of neutral fatty material can then be calculated (A S T M Designation D 94-28, D 128-27, I P T Serial Designation L O 15 r).

When desirable to identify these saponifiable constituents of the oil, the free fatty acids isolated may be further investigated with regard to acid value, iodine value, specific gravity, refractive index, melting-point, Reichert-Messel value, &c. Such identification is tedious and difficult, and reference should be made to the manuals of Lewkowitch [61], Helde [55, 1933], and Archbutt and Deeley [2, 1927] for details of the procedure and for tabulated properties of naturally occurring fatty oils.

Dilution of Crankcase Oil

Among the factors responsible for the deterioration of crankcase lubricating oils in internal-combustion engines is the dilution of the oil by unburnt fuel, which may leak past the piston-rings into the crankcase. (For discussion of the factors responsible for crankcase dilution, see Pigeon and Tester [80, 1929], Skinner [91, 1926].) In the case of gasoline engines the extent of dilution normally varies from 5 to 10%, but may exceed 30% under exceptional conditions, with kerosene fuels and in Diesel engines the dilution may increase to a much greater degree under severe conditions, by reason of the lower volatility of the fuel.

In gasoline engines, owing to the normal crankcase ventilation, the diluent consists of the heavy ends of the fuel and can be estimated with comparative ease, since the physical characteristics of lubricant and diluent are widely different. The alteration in viscosity, flash-point, gravity, and refractive index are unreliable for this purpose, due to change in these characteristics of the oil by factors other

than fuel dilution, and to the necessity of knowing these properties of the original oil

Volatility determination in the form of steam distillation has proved most satisfactory and, after co-operative tests of different methods [85, 1930], the following has been adopted as standard under A S T M Designation D 322-35, and I P T Serial Designation L O 24 (For other forms of steam distillation, see Flowers [33, 1925] and Pigeon and Tester [80, 1929]) The apparatus used closely resembles that for the determination of water in

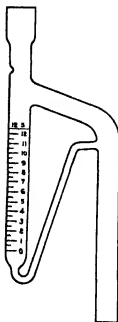

FIG 10 Crankcase dilution determination trap

oils, the trap, however, is constructed to collect and measure the diluent distilling over while returning the condensed water to the still by means of a constant-level overflow tube attached to the bottom of the trap (Fig 10) Twenty-five millilitres of the oil under examination with 500 ml of water are placed in the 1-litre flask and distilled vigorously until the volume of diluent collecting in the trap does not increase by more than 0.1 ml in 15 min The final volume collected, multiplied by four, gives the percentage dilution of the oil Duplicate determinations should agree within 20% for dilutions below 5%, and within 10% if above this value Although this method is satisfactory for power vaporizing oils, it is sometimes preferable to use a vacuum steam-distillation procedure for heavier kerosines [27, 1933]

In the case of compression-ignition (Diesel) engines, the low volatility of the fuel renders efficient separation of diluent and lubricant more difficult, there being an appreciable overlap between the two distillation ranges The subject has been discussed recently in papers read before the World Petroleum Congress and two methods were described giving results of fair accuracy Wilford [109, 1933] carries out a steam distillation at 210° C on 100 ml of the oil, and records the percentage of oil distillate recovered with 200 ml of water From distillations on the original oil and on the oil with known amounts of diluent added, a chart is constructed from which the true dilution can be read off for any distillate recovery from the crankcase samples The method necessitates samples of the original oil and fuel being available, in their absence the distillate recovery will only give an approximate idea of the dilution, although values for the volatility of the oil and fuel can be assumed on the basis of average commercial products

Stark [94, 1933] makes use of a vacuum-distillation method Eight hundred millilitres of the oil are distilled in a special apparatus, with efficient fractionating column, at an initial pressure of 10 mm, this is reduced to 1 mm when a still-head temperature of 158° C at 10 mm is attained The distillation curves for the original and diluted oils are then plotted, the two curves being found to be parallel The intercept between these curves, on a line parallel to the 'percentage distilled' axis, represents the percentage degree of dilution of the oil For this method it is essential that the original lubricating oil is available

Determination of Water

The solubility of water in mineral lubricating oils is very low, according to Flowers and Dietrich [32, 1925] it is of the order of 0.01% for a typical oil, rising to 0.06% at 100° C, but appreciably different solubilities may be shown by different oils Larger amounts of water are shown by a cloudiness in the oil or by the separation of droplets The presence of water in a lubricating oil is generally objectionable, it may collect and obstruct oil circulation, particularly at low temperatures, and is detrimental in wick-feed lubrication due to interference with the capillarity of the wick It may also be a contributory influence in the corrosion of refrigerating machinery, and of engine bearings where sulphurous gases and fatty acids are present

The detection of water in oils may be carried out in several ways by heating a sample of the oil to about 150° C, or by plunging in an iron rod heated to redness, the presence of water is indicated by a crackling sound (the 'Crackle Test'—B S I Specification no 148, 1933), Matthus [68, 1926-7] states that this method will detect water down to 0.0025%. If the oil is heated in a flask, any water present will vaporize and condense on the cool neck of the flask, where it may be identified by the usual chemical reactions

The estimation of suspended water in an oil is usually carried out by centrifugal or distillation methods It is most important that the sample, and the portion of this selected for the estimation, should be truly representative of the main bulk of the oil, the difficulties in obtaining a properly representative sample are unusually great in the case of wet oils

The centrifuge method is used chiefly for fuel oils and crudes, the resultant figure representing the total water plus sediment The procedure standardized under A S T M Designation D 96-30 involves solution of the oil in an equal volume of 90% benzol at 120° F, followed by centrifuging for 10 min

The distillation method is almost invariably employed for the determination of water in the Standard Method of Test for Water in Petroleum Products under I P T—Serial Designation F O 14, and A S T M Designation D 95-30—100 ml of the oil, dissolved in an equal volume of gasoline of specified boiling range, is distilled in a modified Dean and Stark apparatus (Fig 11) The still is a round-bottomed 500-ml flask fitted with reflux condenser discharging into a glass trap which serves to collect and measure the water while returning excess solvent to the flask. The results should duplicate to 0.2 ml Water-saturated xylene has been widely used as a solvent in this

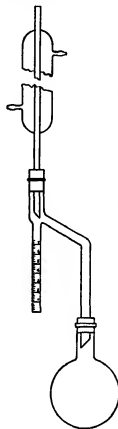

FIG 11 Determination of water (I P T)

method, and in the German procedure the addition of 1% of trolein is stated to reduce any tendency to foam (D V M 3,656)

An alternative form of apparatus is also scheduled under I P T Serial Designation F O 14, in which the gasoline-oil solution is distilled directly into a graduated receiver until the vapour temperature reaches 400° F., the volume of condensed water being noted

For more precise work the method due to Philip [78, 1920] may be used. In this procedure a stream of dry air is drawn through the oil, heated to 100° F., the water vapour in the air being frozen out and collected in a trap Boller [11, 1926] has modified this procedure by employing a stream of inert gas and absorbing the water with calcium carbide. The evolved acetylene is then estimated with ammoniacal copper sulphate. Further methods suitable for liquid petroleum products are described under Gasoline (p 1390), and an extensive bibliography of the methods available for water determination in various materials is given by Fulweiler [36, 1925]

Ash Content

The ash is determined by evaporating a suitable quantity of the oil in a weighed platinum (or silica) dish and finally igniting the residue to constant weight. The actual quantity of oil to be used is dependent upon the amount of ash, and for refined oils as large a quantity as possible should be taken (I P T Serial Designation G O 10). In the case of heavy residual oils, ignition of the carbonaceous residue is facilitated by the addition of hydrogen peroxide or ammonium nitrate, or by passage of a stream of air, which may be mixed with oxygen, during the ignition. If alkali hydroxides or carbonates are present in the ash (from alkali soaps in the oil), strong ignition must be avoided, and it may be necessary to extract with hot water and separately estimate the soluble alkali compounds.

The ash content of a well-refined mineral oil is very low (below 0.01%), but may be considerably higher in the case of heavy residual oils. A high ash content indicates contamination of the oil with adventitious mineral matter, or the presence of soluble metallic soaps. These latter may be derived from inefficient refinery technique, in the case of naphthenates and sulphates, or by deliberate addition. In general the presence of such soaps is undesirable, causing increased tendency towards sludging and emulsification, and their addition for thickening purposes is now rarely practised (the subject of soap-thickened oils is considered under the heading of *Greases*). Lead soaps are present in certain Extreme Pressure lubricants, while the addition of small amounts of oil-soluble compounds of chromium, tin, and lead for improving the oxidation and other characteristics of lubricating oils for internal-combustion engines is receiving some attention.

In the case of used lubricating oils, the ash content may be high on account of the presence of abraded bearing metals, metallic soaps, dust, and other adventitious matter. The iron content of crankcase-lubricating oils has indeed been used as a measure of cylinder wear and therefore of the efficiency of lubrication (See, for example, Merrill *et al* [70, 1935]).

Corrosion Tests

Well-refined mineral oils are found to produce no corrosion of bearing metals unless subjected to severe oxidizing conditions, when the acids produced may have a definitely corrosive action [9, 1933, 72, 1927, 90, 1926]. A badly refined oil may contain corrosive sulphur compounds, free acids, or alkali, while a satisfactory oil is always liable to contamination before or during use, thus the crankcase lubricating oil in internal-combustion engines tends to accumulate sulphur compounds (not necessarily corrosive) from the fuel [21, 1928, 72, 1927].

Free or corrosive sulphur is one of the worst corroding mediums known and should be absent from any well-refined lubricant (nevertheless its presence is desirable in certain wire-drawing and high-pressure lubricants). Free fatty acids may be produced by the hydrolysis under suitable conditions of blended fatty oils or soaps, such acidity, while probably beneficial to lubrication if present in very small amount, may lead to corrosion in the presence of water and under oxidizing conditions [9, 1933, 90, 1926].

The mechanism of corrosion from lubricants is discussed in papers by Bierbaum [9, 1933] and Wawrzyniak [107, 1932].

Due to the diverse conditions accompanying any particular case of corrosion, the standardization of a general corrosion test is hardly practicable. The following methods, however, indicate the lines which may be followed. The degree of corrosion in the case of a test sample may be estimated visually, microscopically, or, when the corrosion products are non-adherent by the loss in weight. It is of particular importance that the metal used for test purposes shall be the same as that in contact with the lubricant during service, since the corrosion produced in any specific case may vary widely according to the metal present.

The following corrosion tests were scheduled by the U S Federal Specifications Board in 1927 (Bur Mines Tech Paper, 323 b)

Method 530-31—corrosion test at 122° F. a clean polished strip of sheet copper is immersed in the oil sample in a test-tube, which is then maintained at 212° F for 3 hr. The copper strip is removed, washed with acetone, and examined for any discoloration or pitting.

Method 530-4—corrosion test for greases, &c. a small quantity of the grease is placed in the centre of a square of polished sheet copper and left for 24 hr. On examination there should be no stain on the copper nor any green discoloration of the grease.

Method 530-2—for soluble cutting oils. polished strips of sheet copper and steel are partially immersed in the oil, contained in corked sample tubes. After 24 hr there should be no pitting or discoloration visible. The copper-dish test (p 1394) has also been used for testing lubricants. In general, a black stain on copper indicates the presence of corrosive sulphur, while a green discoloration of the oil is due to free acidity.

Young [114, 1927] has used a corrosion-testing apparatus, originally designed for marine-engine lubricants, in which a continuous stream of hot oil is allowed to flow over the test samples for prolonged periods (the D O C Test).

REFERENCES

- 1 AMERICAN SOCIETY FOR TESTING MATERIALS *Significance of Tests of Petroleum Products* (1934)
- 2 ARCHBUTT, L., and DELEY, R. M. *Lubrication and Lubricants*, 2nd ed (1927)
- 3 ASHWORTH, A. *J I P T* 10, 787 (1924)
- 4 BACON, F. S. *Ind Eng Chem* 20, 970 (1928)
- 5 BAHLEK, W. H., BARNARD, D. P., ESFINGER, J. V., and FITZ-SIMMONS, O. *J S A E* 29, 215 (1931)
- 6 BARNARD, D. P., BARNARD, E. R., ROGERS, T. H., SHOEMAKER, B. H., and WILSON, R. E. *J S A E* 34, 167 (1934)
- 7 BARR, G. *Monograph on Vaccumetry* (1931)
- 8 BEISWENGER, G. A., and CHILD, W. C. *Ind Eng Chem*, Anal Ed 2, 284 (1930)
- 9 BERBAUM, C. H. *Iron Age*, 132, 20 (31 Aug 1933)
- 10 BLEYFROG, W. *Petr Z* 34, 1416 (1928)
- 11 BOLLER, *Chem Ztg* 50, 537 (1926)
- 12 BOWLES, J. T.-B. *Proc A S T M* 26 (1), 370 (1926)
- 12a BAUN and CLAFFEY *Ind Eng Chem*, Anal Ed 8, 255 (1916)
- 13 BUTKOV, N. A. *Frodt u Teer*, 3, 551, 823 (1927), cf. CHETONAR, L. *J I P T* 20, 168 (1934)
- 14 CHENOSHUKOV, N. I. *Ind Eng Chem* 21, 315 (1929)
- 15 CLAYDEN, A. L. *Proc A S T M* 27 (1), 461 (1927), cf. A S T M Handbook, 1935
- 16 CLAYTON, W. *Theory of Emulsions and their Technical Treatment* (1928)
- 17 CROSS, R. *Handbook of Petroleum, Asphalt, and Natural Gas* (1931)
- 18 DAVIS, A. L., and HORNBERG, C. V. *Nat Petr News*, 25 (38), 65 (1933)
- 19 DAVIS, D. S. *Oil and Gas J* 31 (8), 38 (1932)
- 20 DEAN, E. W., HEN, H. H., SMITH, N. A. C., and JACOBS, W. A. *U S Bur Mines Bull* no 207 (1922), cf. GAVIN, M. J., and FOSTER, A. L. *U S Bur Mines Rept Invest* 2819 (1927), 2996 (1930)
- 21 DIOGH, S. H. *Ind Eng Chem* 20, 16 (1928)
- 22 DIMSHO, H. *Proc A S T M* 23 (1), 363 (1923)
- 23 DONALDSON, J. W. *J S C I* 46, 324 T (1927)
- 24 EHLERS, C. *Petr Z* 26 (15), *Motorenberieb*, 3 (4), 3 (1930), 28 (19), *Motorenberieb*, 5 (5), 2 (1932)
- 25 — *Petr Z* 29 (19), *Motorenberieb*, 6 (5), 2 (1933)
- 26 EVANS, E. A. *J I P T* 9, 384 (1923), cf. *Proc A S T M* 27 (1), 453 (1927), BURBETH, H., and WINKLER, J., *Erdöl u Teer*, 5, 26 (1929)
- 27 — *Lubricating and Allied Oils*, 2nd ed (1933)
- 28 EVANS, R. N., and DAVENPORT, J. E. *Ind Eng Chem*, Anal Ed 5, 82 (1931), 8, 287 (1936)
- 29 FENNER, M. R., and McCLELLER, W. B. *Refiner*, 13, 217 (1934)
- 30 FERRIS, S. W., and McILVAID, J. M. *Ind Eng Chem*, Anal Ed 6, 23 (1934)
- 30a FITZSIMONS, O. *Ind Eng Chem*, Anal Ed 7, 345 (1935), 8, 300 (1936)
- 31 FLOWERS, A. E. *Proc A S T M* 31 (1), 534 (1931), for proposed methods see *Proc A S T M* 24 (1), 545, 659 (1924), 25, 61, 282 (1925), 26 (1), 381 (1926)
- 32 FLOWERS, A. E., and DETRICK, Power, 75, 232 (1925)
- 33 FLOWERS, A. E., McBERTY, F. H., and REAMER, R. *Ind Eng Chem* 17, 461 (1925)
- 34 FORD, J. G. *Ind Eng Chem* 19, 1165 (1927), cf. BAUN, G., *Z angew Chem* 39, 473 (1926)
- 35 FREUND, M., and THAMM, S. *Petr Z* 29 (40), 1 (1933)
- 36 FULWELER, W. H. *Proc A S T M* 25 (1), 416 (1925)
- 37 GALLE, E., and BOHM, M. *Erdöl u Teer*, 8, 76, 91 (1932)
- 38 GARNER, F. H. *J I P T* 7, 98 (1921)
- 39 GARNER, F. H., KELLY, C. I., and TAYLOR, J. L. *Proc World Petr Cong* 2, 448 (1933)
- 40 GRUBB, W. A. *A S T M Symposium on Motor Lubricants*, 7 (1933), *Proc World Petr Cong*, 2, 441 (1933)
- 41 GUINTECH, L., and MOORE, H. *Scientific Principles of Petroleum Technology* (1932)
- 42 GUTHRIE, B., and HIGGINS, R. *U S Bur Mines Repts Invest* 3159, *Nat Petr News*, 24 (12), 27 (1932)
- 43 GUTHRIE, B., HIGGINS, H., and MORGAN, D. *Nat Petr News*, 36 (32), 22, (33), 22 (1934)
- 44 HACEFORD, J. E. *J S C I* 45, 694 (1926), cf. HERSCHHEL and ANDERSON, *U S Bur. Stand Technologic Paper*, no 223 (1922)
- 45 — *Oil Eng Tech* 7, 325 (1926), cf. FRANK, F., and SELBERG, H., *Petr Z* 24, 641 (1928)
- 46 HARLAM, R. T., and BAUER, W. C. *J S A E* 28, 310 (1931)
- 47 HARLAM, R. T., and FROUCH, P. K. *Ind Eng Chem* 19, 292 (1927)
- 48 HEMMER, L. *Ann combustibles liquides*, 7, 589, 859 (1932)
- 49 HENDERSON, L. M., and COWLES, H. C. *Ind Eng Chem*, 19, 74 (1927)
- 50 HEYDEN and TYPKÉ *Erdöl u Teer*, 3, 471 (1927)
- 51 HICKMAN, K., and WEYERTS, W. *J A C S* 52, 4714 (1930)
- 52 HILL, J. B., and COATS, H. B. *Ind Eng Chem* 20, 641 (1928)
- 53 HOBLYN, J. B. *J I P T* 11, 1 (1925)
- 54 HOLDE, D. *Petr Z* 13, 505 (1918), *Kohlenwasserstofföl u Fette*, 7th ed., 25 (1933)
- 55 — *Kohlenwasserstofföl u Fette*, 7th ed (1933)
- 56 — *Erdöl u Teer*, 9, 485, 497, 509 (1933), cf. ERK, S., *Erdöl u Teer*, 9, 122 (1933)
- 57 HOPPER, F. *Proc World Petr Cong* 2, 503 (1933)
- 58 JOHANSEN, E. M. *Ind Eng Chem* 14, 288 (1922)
- 59 KELLY, C. I. *J I P T* 15, 495 (1929)
- 60 LEDERER and STALEY *J S A E* 24, 149 (1929)
- 61 LAWKOWITZ *Chemical Technology and Analysis of Oils, Fats, and Waxes*
- 62 MADSTON, F. M. *J S C I* 36, 270 (1917), 54, 189 T (1935)
- 63 LIVINGSTONE, C. J., MARLEY, S. P., and GAUSE, W. A. *Ind Eng Chem* 18, 902 (1926), 21, 904 (1929), *J S A E* 20, 688 (1927)
- 64 LOUIS, M. *Proc World Petr Cong* 2, 399 (1933)
- 65 MAIR, E. J., SCHUCKANZ, S. T., and ROSE, F. W. *Bur Stand J Ref* 14 (1935), cf. ROSSINI, F. D., *Refiner*, 14, 266 (1935)
- 66 MARCUSON, J. *Chem-Ztg* 51, 190 (1927)
- 67 MARSHALL, A. G., and BARTON, C. H. *J S C I* 46, 130 T (1927)
- 68 MATTHIS, A. *Ingenieur Chimiste* 10, 84 (1926), *Chem abs* 21, 1882 (1927)
- 69 — *Chim et Ind* 27, 503 (1932)
- 70 MERRILL, D. R., MOORE, C. C., and BRAY, U. B. *Refiner*, 14, 313 (1935)
- 71 McCloud et al. *A S T M Symposium on Motor Lubricants*, 27 (1933)
- 72 MERTON, A. F. *Ind Eng Chem* 19, 312 (1927)
- 73 MÖRNERKE, B. H., and VAN BEEST, A. C. *J I P T* 21, 155 (1925)
- 74 MÜLLER, K. O., *Erdöl u Teer*, 8, 235 (1932), cf. WOOD, P., and GIVAUDON, J., *Rev Petroliifre* (408), 105 (1931), Belgian Standard Method, A B S 52 43
- 75 ODELUK, J. W., and LEE, O. I. *Ind Eng Chem* 17, 731 (1925)
- 76 PARSONS, L. W., and WILSON, R. E. *Ind Eng Chem* 14, 269 (1922)
- 77 PETERKIN, A. G., and FERRIS, S. W. *Ind Eng Chem* 17, 1248 (1925)
- 78 PHILIP, A. *J I P T* 6, 43 (1920)
- 79 PHILLIPOVICH, von *Erdöl u Teer*, 9, 267 (1933)
- 80 PHOEN, D. G., and TINTER, H. E. *J I P T* 15, 91 (1929)
- 81 RALSTON, R. R., FELLOWS, C. H., and WYATT, K. S. *Ind Eng Chem*, Anal Ed 4, 109 (1932)
- 82 RATHER, J. B. *Proc A S T M* 32 (1), 401 (1932)
- 83 RODGROVE, E. R. *J I P T* 21, 612 (1935)
- 84 ROGERS, S. M., and ADKINS, L. R. *Ind Eng Chem* 20, 742 (1928)
- 85 ROGERS, T. H. *Proc A S T M* 30 (1), 782 (1930)
- 86 ROGERS, T. H., GRIMM, F. V., and LEMONN, N. E. *Ind Eng Chem* 18, 164 (1926)
- 87 SAAL, R. N. J., and VERVER, C. G. *J I P T* 19, 336 (1933)
- 88 SACRANEN, A., and VASELINV, N. *Petr Z* 23, 1618 (1927)
- 89 SALOMON, T. *Compt rend congr graulzage, Strasbourg*, 373 (1931), *Chim et Ind* 29, 811
- 90 SINGLETON *Ind Chemist*, 2, 540 (1926)
- 91 SKINNER, R. L. *J S A E* 19, 275 (1926)
- 92 SLOAN, T. S. *Oil and Gas J* 24 (2), 125 (1925)
- 93 SOUTHGOMME, J. E. *Lubricating Oil Tests* (1932)
- 94 STARR, A. R. *Proc World Petr Cong* 2, 471 (1933)
- 95 STEINER, L. *Proc World Petr Cong* 2, 483 (1933), *Petr Z* 30 (6), *Motorenberieb*, 7 (2), 2 (1934)
- 96 STELLING, C. Z. *angew Chem* 39, 538 (1926)
- 97 STOUT, B. W., and KALICHEVSKY, V. A. *Ind Eng Chem*, Anal Ed 5, 214 (1933)
- 98 THEILL, E. W. *Ind Eng Chem* 19, 259 (1927)
- 99 THORNYCROFT, O., and BARTON, C. H. *Abstract Engineering*, 56 (1930)
- 100 URSLODDE, L. *J I P T* 19, 376 (1933), 22, 32 (1936)
- 101 VELLINGER *Compt rend congr graulzage, Strasbourg*, 117 (1931), *Ann combustibles liquides*, 8, 301 (1932)
- 102 VERVER, C. G. *Proc World Petr Cong* 2, 417 (1933), VAN WUK, *J I P T* 22, 754 (1936)
- 103 VOORL, H. *Erdöl u Teer*, 3, 534 (1927)

- 104 WALTHER, C *Erdöl u Teer*, 5, 223 (1929)
105 WATERS, C E *Ind Eng Chem* 13, 901 (1921)
106 WATSON, K M, and WIRTH, C *Ind Eng Chem*, Anal Ed 7, 72 (1935), BEALE and DOCKREY, *J I P T* 21, 859 (1935)
107 WAWRZESNICK *Automobiltechn Z* 35, 428, 600 (1932)
108 WEIR, H M, HOUGHTON, W F, and MAJEWski, F M *Ind Eng Chem* 22, 1293 (1930)
109 WILFORD, A T *Proc World Petr Cong* 2, 463 (1933)
110 WILKIN, OAK, and BARNARD *J S A E* 22, 213 (1928)
111 WINDING, C *Ind Eng Chem*, Anal Ed 2, 417 (1930)
112 WOOD, P *Proc World Petr Cong* 2, 412 (1933)
113 WYANT, L D, and MARSH, L G U S Bur Mines Tech Paper, no 368 (1925)
114 YOUNG, H J *J I P T* 13, 760 (1927), *Oil and Gas J* 26 (27), 146 (1927)

METHODS FOR THE ANALYSIS OF FUEL OIL

By F. B. THOLE, D.Sc., F.I.C.

Chemist, Anglo-Iranian Oil Company Ltd

FUEL OIL is a term the significance of which differs in different countries. In some languages, therefore, special words are employed to characterize the type of fuel referred to (e.g. 'mazout' implies a furnace fuel oil). In English, qualifying adjectives are often used, thus the terms bunker fuel oil, domestic fuel oil, distillate fuel oil, Diesel fuel oil, high-speed Diesel fuel, and aero-Diesel fuel each give a significant though not a precise indication of the characteristics of the material. In England 'fuel oil' without further qualification generally implies a residuum obtained from a crude oil by removal of sufficient of the lighter hydrocarbons to raise the flash-point above 150° F. In America the term, when unqualified, is generally understood to indicate a distillate corresponding more or less with the English term 'gas oil'. In both countries blends of distillate and residuum in the proportions necessary to meet required limits of viscosity, asphalt, sulphur, &c., are extensively used as fuels. Fuel oil often contains also a variety of refinery by-products such as soft wax, cracking-plant products of high boiling-point, extracts derived from solvent extraction processes, &c., which do not lend themselves to further refining.

It is usually possible to distinguish distillate fuel oils such as gas oil from residuum fuels or residuum-distillate blends by the fact that the distillate fuel generally has a final boiling-point not exceeding 380° C, and is practically free from asphaltenes.

In the following review of analytical tests the term fuel oil will be restricted to those oils which are not wholly distillate, though it will be appreciated that the majority of the descriptions and comments apply equally to all classes of fuel oils.

Most of the tests employed in connexion with fuel oils have been standardized in America by the American Society for Testing Materials, and in England by the Institution of Petroleum Technologists and are described in full in the respective handbooks of these societies, which should be consulted for detailed descriptions under the references given in the following pages. The comments given in this review are intended to deal with the significance of the tests and not with the experimental details of operation.

Specific Gravity (I.P.T. G 1, A.S.T.M. D 287-33)

In the case of fuel oil, as with other petroleum products, this factor is only remotely related to the character and quality of the material. It cannot even be used as a check on the uniformity of successive consignments of oil, for the components of oil fuel may readily be varied without altering the specific gravity of the ultimate blend. Specific gravity data are therefore of use only for calculations relating weight to volume.

Distillation Range.

A test of this nature is very rarely required, and none has therefore been standardized. If information regarding the boiling range is required, the general apparatus and procedure for gas oil (I.P.T. G O 3, A.S.T.M. D 158-28) is

convenient. The sample should be dried before distillation (I.P.T. S 2) and the incidence of cracking at about 380° C. should be borne in mind.

Flash-point.

This is the temperature at which, under standardized conditions, the air space above the oil contains sufficient oil vapour to be ignited by a flame. This temperature will depend on whether the air space is enclosed, restricted, or open, as well as on the oil/air ratio and other experimental factors, so that the method of test must of necessity be specified.

The minimum flash-point by the closed cup method is included in a number of legal and shipping requirements and is related to the fire hazard. In the U.S.A., for domestic installations the usual minimum limit for flash-point is 100° F and for commercial installations the customary requirement is a minimum of 150° F. In England the usual limit for flash-point of fuel oils is 150° F minimum.

In Great Britain and America the standard apparatus is the Pensky Martens Closed Tester (I.P.T. G O 7, A.S.T.M. D 93-22), while by removal of the lid of this apparatus an Open Flash-point Test (I.P.T. L O 7a) may be made.

In America open flash-point tests are used for many products, but fuel oil is specifically excluded. In France a semi-open apparatus, the Luchaire, is used, in which a gentle, continuous air-stream is induced over the surface of the oil and an ignition flame held in this air-stream.

The presence of water, even in small amount, renders the determination of flash-point difficult and even impossible, so that preliminary drying of the sample is often necessary. Flash-point is also affected by changes in atmospheric pressure to the extent of 1.6° F decrease for each inch of mercury above normal (29.92 in.), this effect is of importance in border-line cases where a consignment of oil may show a flash-point very close to the Board of Trade minimum of 150° F.

It should be clearly appreciated that 'flash-point' has no relation whatever to 'spontaneous ignition-point', which is the temperature at which a mixture of oil vapour and air will ignite without the application of a local source of ignition such as a flame or spark.

The closed flash-point of fuel oils in general lies between 150 and 200° F, the former figure being laid down as a minimum in most specifications including those for marine purposes and for the great majority of land industrial purposes.

Viscosity (I.P.T. L O 8, A.S.T.M. D 88-33)

Expression of viscosity of fuel oils in absolute units has so far achieved practically no acceptance, and results are invariably quoted in terms of the Redwood (England), Saybolt (America), or Engler (continent of Europe) viscometers. In the two former cases two forms of the instrument exist. The Redwood Viscometer No. 1 gives a time of flow for a given oil 10 times as great as the No. 2.

viscometer, the former is used for times of flow up to 2,000 sec. and the latter for viscous oils where the viscosity in the No 1 instrument would exceed 2,000 sec. Neither instrument is suitable for use with oil so mobile that the time of flow is below 30 sec.

The Saybolt Universal Viscometer and the Saybolt Furoil Viscometer bear the same relationship to one another as Redwood No 1 and Redwood No 2, but the Furoil Viscometer is more frequently used in America for fuel oils than is the Redwood No 2 in England. The Furoil instrument may not be used, however, for times of flow below 25 sec.

On the continent of Europe the Engler viscometer is in general use, results being expressed in terms of 'Degrees Engler', the ratio of the times of flow of the sample and of water from the instrument.

An approximate relation between these three scales of measurement is

$$\begin{aligned} \text{Redwood (I)} &= \text{Saybolt (Univ)} \times 0.85 \\ &= \text{Engler Degrees} \times 30 \end{aligned}$$

More accurate conversion data are given under Viscosity, p 1071

The determination, expression, and use of viscosity data for fuel oils is greatly complicated by the fact that below a certain temperature nearly all oils cease to behave as true liquids and acquire the properties of colloidal gels. They therefore cease at this point to possess a definite viscosity, and the apparent viscosity may vary over a very considerable range depending on the mechanical and thermal treatment which the oil has recently undergone. Thus an apparently 'solid' oil may flow freely when once it has been gently stirred or if it is submitted to a pressure of a few inches of water. Conversely, an oil which flows readily at, say, 32° F may acquire appreciable rigidity and cease to flow from a viscometer or a sample bottle if it is maintained at 32° F for a period of time. In order to eliminate, at least to some degree, the variation in results induced by previous mechanical and thermal history, the I P T Standard Method of Test defines the conditions of preliminary heat treatment. Since, however, the complication is due to the presence of solid or plastic waxes, the determination of viscosity should, if possible, be made only at temperatures above the cloud-point, and it is, in general, customary not to determine the viscosity of fuel oils below 100° F. The nature and behaviour of the oil at lower temperatures can be better assessed by the pour-point.

Cloud-point (I P T L O 11, A S T M D 97-34)

This test, which determines the temperature at which wax commences to separate from solution in the oil, is rarely applied to the fuel oils under discussion, although it is more often employed for the all-distillate oils used by some classes of Diesel engines. Its chief use is met in cases where the oil has to pass through an unheated filter of very fine mesh where suspended solid wax crystals would be liable to collect on the filtering surface and restrict the rate of filtration.

The standard method of test is limited to oils transparent in layers $\frac{1}{16}$ in thick, but methods for judging the cloud-point of a dark oil are sometimes required. One method is to place a drop of the oil on a water-jacketed microscope slide and slowly reduce the temperature of the water until visible separation of wax is observed. On account of the thinness of the film, quite dark oils can be tested in this way. Another method is to precipitate most of the asphaltic

material by sulphuric acid and then to examine the clarified oil by either the microscopic slide or the standard cloud-point method. This clarification is carried out by agitating the sample vigorously with between 1 and 3% by volume of concentrated sulphuric acid (96%), allowing the acid to separate and remove the last particles of acid by stirring the oil with a small amount of decolorizing clay and filtering. As some difference of opinion exists as to whether such acid treatment is without effect on the cloud-point, it would seem preferable to use the microscopic method directly on the sample where possible and only to employ acid treatment if this cannot be avoided.

Four-point (I P T L O 11, A S T M D 97-34)

This test records the lowest temperature at which the oil will flow when it is chilled without disturbance under definite prescribed conditions. It must not be confused with setting-point (I P T L O 11a), which is generally restricted to lubricating oils and which involves an entirely different apparatus and technique.

The technique of the determination involves a test at each interval of 5° F, so that a recorded pour-point is the lowest temperature, being a multiple of 5, at which the oil will flow under the conditions of the test.

Owing to the peculiar physical condition of petroleum oils (especially residuum oils which contain wax and asphalt both dissolved, suspended, and in colloidal condition), the anomalous behaviour described in connexion with viscosity is also manifested in relation to pour-point, which, like viscosity, is dependent to a marked degree on the thermal and mechanical history of the sample.

If a fuel oil is preheated to various temperatures before the pour-point test is made, it will usually be found that the maximum value for pour-point is recorded when the preheating temperature is about 115° F, though the exact minimum of the curve varies somewhat with the particular oil under examination. The standard method of test consequently prescribes a previous heat treatment of 115° F, and the pour-point then obtained is a maximum figure. This figure may be quite remote from that at which the oil will flow under higher pressures or with mechanical agitation. Thus an oil with maximum pour-point of 50° F may be cooled in a bottle to 30° F and be apparently solid, but if the bottle is shaken the contents revert at once to a fluid which may be readily poured. Similarly, such an oil can be readily pumped at 30° F, although, on the other hand, it would probably not flow through a small-diameter pipeline under a small head. If the oil is preheated to a series of temperatures above 115° F, the pour-point recorded steadily falls, reaching a minimum value at a pre-treatment temperature of 220° F. The pour-point determined under these conditions is termed the minimum pour-point and may be as much as 60° F below the maximum pour-point.

The erratic behaviour of fuel oils when exposed to low temperatures has been reviewed at length by Moerbeek and van Beest [2, 1935], who point out the misleading tendencies of both the maximum and minimum pour-point figures and ascribe the phenomena to the separation of asphaltenes on the surface of the wax crystals. An alternative method of test is put forward by them in which a somewhat different system of thermal pre-treatment is laid down, and the test conducted in a different form of apparatus. It is claimed—probably correctly—that such a method of test gives information in closer concord with the actual behaviour of the oil in service.

Calorific Value (Gross) (I P T G O 6, A S T M D 240-27)

The gross calorific value of a fuel oil is the value obtained when a weighed amount of the oil is burned in an atmosphere of compressed oxygen and the resultant water allowed to condense in the apparatus. The net calorific value cannot be determined directly, but can be calculated from the gross value by deducting the latent heat of condensation of this water.

Some of the details of the method of determination laid down by the I P T and the A S T M differ, but the effect on the final result is insignificant.

The gross calorific value of fuel oils usually lies between 18,000 and 19,200 B T h U per lb. The highest values are obtained when elements other than carbon and hydrogen are at a minimum, and especially where the hydrogen/carbon ratio is high. Asphaltenes and, in particular, oxygen and sulphur compounds reduce calorific value, so that as a rule the more asphaltic fuels with high oxygen or sulphur content have the lowest heating value.

If the fuel oil contains any appreciable quantity of coal-tar products such as creosote oil, the presence of oxygen in the phenols markedly reduces the calorific value, so that such oils are, as a rule, readily distinguishable from petroleum fuel oils. The low hydrogen/carbon ratio of coal-tar products also depresses the calorific value.

Various formulae, usually derived from the following,

Cal value (calories per gram)

$$\frac{C \times 8,137 + (H - O/8) \times 34,500 + S \times 2,500}{100}$$

where C, H, O, and S are the percentages of the respective elements, have been proposed for the calculation of calorific value from elementary composition, but they are rarely used where direct determination is possible, and can only be regarded as very approximate.

Although in actual practice oils are burnt under such conditions that the water of combustion is not condensed, so that the net calorific value would be a truer index to their potential energy content, the determination of this quality is so laborious that it is very rarely undertaken. If it is to be done, it is necessary to carry out an analysis of the oil to ascertain its hydrogen content, and then to deduct 54 calories (97 B T h U) for each 1% of hydrogen.

It is usually sufficiently accurate to assume for petroleum fuel oils that the net value is about 1,200 B T h U per lb below the gross value.

Asphaltenes (I P T F O 12)

Asphaltenes, or 'hard asphalt', constitute the non-volatile dark brown or black material of high carbon/hydrogen ratio (frequently also containing sulphur and/or oxygen) which is present in the majority of residuum fuel oils, and which is insoluble in petroleum spirit. The proportion may range from almost zero in the case of certain oils from Pennsylvania, Burma, and the Dutch East Indies to over 5% in certain Mexican oils. A high proportion of 'hard asphalt' is frequently, though by no means inevitably, associated with a high viscosity. Since 'asphaltenes' do not constitute a specific substance, they can only be defined arbitrarily, and for analytical purposes they constitute those components of petroleum which are precipitated under specified conditions by petroleum spirit of a specified nature as defined by its specific gravity and boiling range. Since asphaltenes are soluble in aromatic

hydrocarbons, the precipitant must contain not more than 0.5% of such hydrocarbons. In carrying out the analysis the following points are of special importance:

- The amount of precipitated asphalt must be small in quantity (not over 0.25 g.)
- The ratio of precipitant to oil must be strictly maintained.
- The washed precipitate must be thoroughly separated from the wax which accompanies it, by subsequent extraction with boiling alcohol.

The asphaltene content of a fuel oil is of no import as such if the oil is to be employed as an industrial or marine furnace oil, though, as has been stated, it is often associated indirectly with high viscosity and low calorific value. For internal-combustion engines and for domestic heating plant the content should be relatively small, for asphaltenes are non-volatile and are liable to accumulate and carbonize on hot metal surfaces such as sprayer nozzles. Since, however, other components of an oil also do this, the tendency can be assessed more accurately by a direct test, such as the Carbon Residue Test.

Aniline-point (I P T F O 23)

This property is defined as the lowest temperature at which the oil is completely miscible with aniline. It is a measure of the 'paraffinicity' of an oil, as paraffins have a higher aniline-point than the other classes of hydrocarbons. Since 'paraffinicity' in a Diesel fuel implies, generally, easy starting and a minimum of 'knock', a high aniline-point is usually indicative of a high cetene value and affords a moderately satisfactory laboratory alternative to an actual engine test for cetene value, provided that the fuel in question is a petroleum oil and not doped with 'anti-knock' chemicals such as ethyl nitrate. Shale oils usually have a higher cetene value than would be anticipated from their aniline-point.

Sulphur (I P T G O 4, A S T M D 129-34)

Sulphur in fuel oils is determined by burning a weighed amount of the oil in a bomb filled with compressed oxygen and determining gravimetrically the sulphuric acid produced. The British and American standard methods differ only in minor details.

The sulphur content of a fuel oil may be as low as 0.2% or rise to over 5%. For ordinary furnace purposes the sulphur content of an oil is of no importance and is rarely included in specifications. Certain metallurgical operations, such as heat treatments in which the properties of the metal are seriously affected by traces of sulphide, demand fuels of the lowest sulphur content obtainable. Occasionally flue systems are such that undue cooling permits the temperature of the flue gas to fall below the dew-point, and a condensation of corrosive acid moisture results, but such cases of faulty design are quite exceptional. Corrosion from condensation of dilute sulphuric acid has been known to occur in the exhaust systems of Diesel engines if these are overcooled. Since, however, all fuel oils contain some sulphur, it is clearly preferable to avoid condensation than to restrict the available fuels by limiting the sulphur content.

When the gaseous products of combustion of sulphur-containing oils are non-corrosive, the flame of such oils always contains hydrogen sulphide and free sulphur, both of which readily attack heated iron. It is important, therefore, that oil flames should not be allowed to impinge on the metal.

Spontaneous Ignition Temperature (see p 2970)

This is regarded as the lowest temperature at which a fuel will ignite, in the presence of air or of oxygen, without the application from external sources of a flame or spark. Since the temperature varies very considerably according to the experimental conditions, no great importance is placed on this quality, though it is clear that the lower the S I T the more easily will the fuel ignite in a Diesel engine. In the form of apparatus used by Moore (a modification of the arrangement originally employed by Holm and by Konstam and Schlapfer) a platinum crucible was mounted in a heated metal block containing a pyrometer, and a gentle stream of oxygen was circulated through the crucible. At steadily decreasing temperatures drops of oil were allowed to fall into the crucible, and the lowest temperature was recorded at which spontaneous ignition occurred. Petroleum oils ignite in oxygen at about 250° C and coal-tar oils at about 400° C. Among petroleum oils the more volatile fractions have higher S I T's than the heavier fractions. On account of the residues left by asphalt-containing oils the test cannot be considered suitable for such oils, and for assessing the ignition quality of a Diesel fuel aniline-point is generally accepted as the best index pending the standardization of a direct engine test.

Wax.

Since all fuel oils contain some wax in solution, and often also in suspension, much research has been devoted to methods for its quantitative determination, but no method has yet proved satisfactory or acceptable. One difficulty lies in the definition of the term, since 'wax' is a mixture of numerous hydrocarbons. The solid, crystalline, waxy hydrocarbons in heavy petroleum residues are, moreover, accompanied by other hydrocarbons of a vaseline-like nature which cannot be separated from them by solvents, and which decompose on distillation, generating oil and crystalline wax.

One method which has been proposed for determining 'wax' consists in dissolving the sample in 10 volumes of petroleum ether and de-asphalting by three successive washes with 1 volume of concentrated sulphuric acid. The resultant petroleum ether solution is washed with water and alkali, the solvent distilled off, and the residue analysed for wax content by the following procedure.

About 3 g of the waxy oil are weighed into a conical flask, dissolved in 100 ml of pure dry acetone, and the solution cooled at the rate of 5° F per minute to -10° F and maintained at this temperature for 15 minutes. The wax is then filtered off in a funnel jacketed with a cooling medium maintained at -10° F, using gentle suction. The slightly oily wax so obtained is dissolved in hot petroleum ether and the solution transferred to a tared glass dish and evaporated till substantially free from solvent and the whole weighed to ascertain approximately the weight of the crude wax. This crude wax is then dissolved in petroleum ether, the solution transferred to the original conical flask, the solvent removed, and the wax dissolved in boiling acetone, using 70 ml of this for each gram of wax. This solution is cooled and filtered as before, operating this time at 32° F, and the twice-precipitated wax ultimately dissolved in petroleum ether, transferred to a weighed dish and weighed after complete removal of the petroleum ether solvent. This double precipitation is essential for removing all the liquid oil, though if prepared from non-distillate oils this wax still contains a small amount of 'vaseline'.

It will be noted that 'wax' is arbitrarily defined in this test as material insoluble in acetone at 32° F.

Another method often used is that of Holde. In this method a weighed quantity of the oil is distilled rapidly to a coke residue and the wax is isolated from the distillate by precipitation at -20° C with a mixture of equal volumes of ethyl alcohol and ether. This, again, is an empirical method which further involves a certain amount of destruction of wax and vaseline-like bodies by cracking.

The significance of wax in fuel oil lies mainly in its influence on the pour-point, but as this factor can be determined directly, the tedious and uncertain operation of determining 'wax' is rarely undertaken.

Carbon Residue (Conradson Method) (I P T G O 9, ASTM D 189-30)

This method of test is a means for determining the amount of carbon residue left on evaporating an oil under specified conditions, and is intended to throw some light on the relative carbon-forming propensities of oils.

The method consists in heating a weighed amount of the oil in a covered crucible at a rate which ensures steady volatilization, and finally an ignition of the residue at a red heat for 7 minutes. The residue of carbon is weighed and expressed as a percentage.

Another method, the Ramsbottom Method, in which the oil is heated in a glass bulb, is used to some extent for lubricating oils, but is not employed for fuel oils. The results from these two methods are not comparable, as the conditions of heating affect oils in different ways.

The sources of carbon residue are chiefly the asphaltenes and the resins and oils of very high boiling-point, which decompose before they volatilize.

The carbon residue figure gives some indication of the extent to which carbonaceous deposits may accumulate on heated surfaces, such as burner nozzles, on which drops of the fuel may fall and partially evaporate and the remainder carbonize. Other factors, however, exert so much influence on the extent of this action that little importance is attached, as a rule, to the carbon residue figure for a burner fuel.

Water (I P T F O 14, ASTM D 95-30).

The test consists in boiling a known volume of the oil with a volatile solvent under reflux in a form of apparatus in which the water is transferred to a graduated tube and the solvent is returned to the boiling flask.

Distillate fuel oils are generally free from water, but residuum oils are rarely dry owing in part to their greater viscosity, which hinders the setting of water droplets, and in part to the emulsion-stabilizing properties of the asphaltenes.

The quantity of water in suspension in residuum fuel oils is generally between 0.3 and 1.0%, but occasionally reaches 2% in viscous asphaltic oils. So long as the water is finely divided it gives rise to no practical difficulties, these are liable, however, to arise if the specific gravity of the oil is approximately the same as that of water, in which case relatively large pockets of water may float stably in the oil and, on reaching an oil-burner, extinguish the flame. Such oils, however, are generally preheated when the specific gravity and viscosity of the oil both fall considerably, and separation of water becomes reasonably rapid.

Sediment (I P T F O. 14a)

This is defined as material insoluble in benzole, and con-

sists essentially of adventitious debris such as iron rust, tank scale, &c. It may also consist in part of salt, sand, or earth which accompanied the crude oil from the well and which had not effectively settled out in transit or in process. In the case of furnace fuel its objectionable effects lie in the risk of clogged filters and burner nozzles, while salt would be liable to flux firebricks. In the case of Diesel fuel the coarser particles would, of course, be removed by the filters, but very fine mineral matter would be liable to pass these and cause serious cylinder wear by abrasion.

No method for the determination of sediment has been standardized by the American Society for Testing Materials, but method 300 2 in the *Methods for Sampling and Testing Lubricants and Liquid Fuels*, Federal Specification VV-L-791, p 68, was used in the Bunker C specifications which prescribed a maximum sediment content of 0.25%. More recently this has been replaced for U S naval requirements [1, 1934] by clauses stating that the oil should be free from tendency to deposit excessively in fuel-oil heaters under certain specified conditions, and also free from a tendency to sludge excessively in storage at temperatures from 40 to 100° F. The apparatus and pro-

cedure are described in the *Proceedings of the American Petroleum Institute* for 1936 [3, 1936], which permit the production of this service characteristic. It is pointed out that conventional physical tests and inspections do not offer a satisfactory means of rating or grading fuels as regards their tendency to coat heater coils with a deposit which retards heat transfer.

Ash (I P T G O 10)

This is determined by evaporating a suitable quantity of the oil in a platinum or silica dish and finally igniting to remove all volatile and combustible matter. The ash is not necessarily identical with the 'sediment insoluble in benzene', for some residuum oils contain small proportions of elements, such as nickel and vanadium, in the form of oil-soluble compounds. The ash, like the sediment, can in general be regarded as a measure of abrasive material in the oil, and is of importance when the oil is intended as a Diesel fuel. In fuel for glass-melting furnaces, where traces of iron and manganese oxides are liable to cause discoloration of the glass it may be necessary to impose limits on the content of these metals.

REFERENCES

- 1 McGEARY, F. M. *J. Amer. Soc. Naval Eng.* 46, 217 (1934)
- 2 MOERBEK, B. H., and VAN BERT, A. C. *J. I. P. T.* 21, 155 (1935)
- 3 *Proc. A. P. I.* 17 (3), 17 (1936)

GENERAL METHODS OF ANALYSIS OF WAXES

By W. J. WILSON, F.I.C., A.C.G.I., M.Inst.P.T., and R. E. DOWNER, B.Sc.
Burmah Oil Company, Ltd

PETROLEUM waxes can be classified into three categories, as follows

- 1 Fully refined paraffin waxes
- 2 Scales and partly refined scales
- 3 Petroleum cereasins

Certain tests and methods of analysis assume varying degrees of importance and significance according to the class to which the wax under examination belongs. This fact will be evidenced as the methods are described.

A. Colour

1 The I.P.T. standard method (Serial Designations P.S. 2 and 2a) utilizes the Lovibond tintometer, the cell of which may be kept warm by a jacket or by insertion between two electrically heated mats or elements. In the case of fully refined paraffin wax, the 18-in. cell is used, and the 5-in. for scales, in conjunction with a selection of Yellow (series 510) and Red (series 200) standard glasses. The method consists in freeing the molten wax from suspended matter by filtration, and placing sufficient of the sample in the Lovibond cell to cover the whole rectangular space of the cell as viewed through the eyepiece. In watching the colour with the glasses, provided it is stipulated that the Red glasses shall be used to a minimum in favour of the Yellow ones, the result is expressed as *a* (units) Yellow plus *n* (units) Red.

Other colorimeters or tintometers are in use, such as those of Saybolt and Stammer, but they have no advantages over the Lovibond.

It can be taken as a general rule that the lighter the colour of the wax under examination, the more efficient has been its refining. Quantitative deductions from results of this test are, however, not possible.

2 D. Bargman [2, 1934] describes a method developed by A. M. Rabinovitch and C. Abakowa of measurement of the colour of paraffin wax in the solid state. The sample under test was melted and heated to 60–70° C., transferred to a vacuum desiccator, where it was allowed to cool slowly to room temperature. By this means the wax was freed from air bubbles and mottles. The cake produced was cut into plaques of exactly 1 cm. thickness, which were placed on a warm glass plate for a few seconds to obtain a homogeneous matt surface. By use of a Stammer colorimeter and a dichromate solution containing 6 mg. potassium dichromate and 0.5 mg. Congo red per litre of water, the colour of the prepared plaque of wax was expressed as the height in millimetres of the corresponding column of dichromate solution. It is claimed that this method is more sensitive than that of measurement of the colour in the liquid state, and that the height of the matching dichromate solution is inversely proportional to the stability of the wax. This method is not intended for scales, the oil content of which being such as to confuse any deductions possible.

B. Odour

This physical property is of the greatest significance in regard to fully refined commercial waxes, particularly with reference to their widespread use in the waxed-paper

industry, in which freedom of the coating from odour is a most desirable property. There is no scientific test for assessment of this property, and although divergence of opinion between different operators is possible when a test is made, it is a valuable qualitative guide which can be developed to a marked degree of sensitivity after considerable experience. It must be added, however, that it would appear doubtful whether it is possible to obtain a petroleum wax which is perfectly odourless in the liquid state at 100° C., as the purest wax possesses a very slight 'waxy' odour.

The qualitative test consists of smelling, in a fresh and inert atmosphere,

- (a) a piece of freshly fractured wax at room temperature,
- (b) the liquid sample at 100° C., contained in a clear glass beaker.

The sample is melted in a water-bath, and it is important that the sample be not locally overheated.

C. Taste

The tasting of a sample is a useful supplement to the odour test and consists of chewing a piece of the freshly broken sample under examination. By this means the presence of traces of light oil such as kerosene is readily detectable.

D. Acidity

It is important that fully refined waxes should possess no acidity. Acidity is estimated by refluxing with 95% neutral alcohol and titrating with standard caustic potash, phenolphthalein being the indicator. Any acidity is most probably due to incomplete removal of sulphuric acid used in the refining operation, or of products therefrom.

E. Moisture

The standard I.P.T. method (Serial Designation P.S. 14) is generally used. 50 g. of the sample is heated to 130° C. in a dish until no further evolution of gas occurs. The loss in weight represents the moisture. This test may assume considerable importance in the case of refined waxes for use in the electrical industry as the dielectric for paper condensers.

F. Stability to Light

Most refined waxes, on exposure to sunlight, acquire a yellow colour, the depth of which depends upon (a) the oil content, (b) the nature of the oil, (c) the degree of refining, and (d) the strength of the light and time of exposure. Rabinovitch and Abakowa have proposed a method of determination of the resistance of paraffin to light by utilization of ultra-violet rays from a mercury vapour lamp. The paraffin plaque, prepared as described previously, is exposed to the lamp (2.5 Hefner candles) for a definite number of hours, and is then kept in the dark for 8 hours to reach stability. The colour is measured by the Stammer colorimeter, with the potassium dichromate solution already referred to. This is claimed to be a sensitive test of the colour stability of waxes.

G. Density and Aniline-point

The critical solution temperature of waxes with aniline has been proposed as a constant by Katarakis and Megelalou-kommas [13, 1932]. The aniline-point of different waxes are recorded, but it is not shown whether the constant could be used as a means of analysis and differentiation between paraffin waxes.

The density of paraffin wax in the solid state has been determined by Morris and Adkins [15, 1927] and Pyhala [18, 1922]. Its variation with temperature has also been investigated. This property does not appear to be a suitable basis of evaluation.

H. Sweating Test

The value of a slack wax or scale depends to a large extent upon the ease with which it can be worked up to the required degree of purity. Holde [11, 1902] describes a sweating test whereby the merits of a given scale can be assessed. In brief, the method consists of sweating the scale (i.e. raising the temperature of the scale gradually whereby low melting-point wax and oil are released) to a residue of de-oiled paraffin and working up the waxes by repeated sweating to obtain the maximum yield of refined paraffin. The method has not been developed to a scientific test, chiefly because of the difficulty experienced in estimating oil in the various fractions obtained from the sweating procedure. It is further complicated by the fact that the crystalline structure of the original scale, as well as its oil content and the rate of sweating, has great influence upon the results obtained.

Although this test is not satisfactory for a scale unless the conditions be vigorously specified, it is of definite value in the assessment of semi-refined waxes of low melting-point such as 'Match Wax'. This wax is utilized in the match industry for dipping match heads, and it is important that it contains a minimum of very soft paraffins and oil. One form of the test consists of sweating a cube of the wax of defined dimensions for 4 hours between filter-papers in an air oven at 90° F. The value of the match wax is dependent upon the loss in weight of the sample, the lower the loss the more suitable being the wax for its purpose.

I. Setting-point

At the present time commercial waxes and scales are graded according to their setting-points, generally designated melting-points. The I.P.T. defines setting-point as the temperature at which melted paraffin wax, when allowed to cool under definite specified conditions, first shows a minimum rate of temperature change. Since petroleum waxes are composed of a wide range of paraffin hydrocarbons, it is evident that there is no means of determining the 'absolute' value of the setting-point, particularly as solid solutions exist [16, 1928]. The result obtained, therefore, is dependent upon the conditions prevalent during the test. If the conditions of cooling, or the quantity of material taken for test, are varied, different results will be obtained, hence no two dissimilar methods of determination of setting-point give identical results. In the cooling of a wax mass, fractional crystallization occurs to a certain extent, and it is therefore of the utmost importance to test, when possible, a portion of the melt from a whole slab of wax.

1. A.S.T.M. (Serial Designation D. 87-22) Standard Method. The apparatus consists of a suitable cylinder acting as a water-bath, immersed in which is a thermometer. Inside the former is a concentric air-bath which surrounds

the wax container, a glass tube which contains the setting-point thermometer and a metal stirrer. The whole apparatus is of specified dimensions, the air-bath and wax container being securely corked. The procedure adopted for carrying out the test is as follows. The average sample of wax is melted on a water-bath and its temperature brought to about 35° F above its approximate setting-point. It is then poured into the wax container to a height of 2 in. The setting-point thermometer (of standard dimensions) is corked concentrically into the wax container so that its lower end is $\frac{1}{2}$ in from the bottom. Water at a temperature of 60-80° F is poured into the water-bath to within $\frac{1}{2}$ in of the top, and the wax container is secured in the air-bath so that the bottom of the former is within $\frac{1}{2}$ in of the bottom of the air-bath. The temperature of the water-bath is adjusted to 25-30° F lower than the temperature of the wax sample under test when the latter has cooled to a temperature 10° F above its approximate setting-point. The wax is stirred continuously and regularly, the temperature on the setting-point thermometer being read at intervals of 30 seconds to within 0.1° F. The temperature of the wax falls gradually at first, then becomes nearly constant, and again falls gradually. Readings are taken during a period of at least 3 minutes after the temperature begins to fall subsequent to the stationary period. The average of the first four readings that lie within 0.2° F are taken as the setting-point.

It has been found that certain waxes do not give a setting-point as defined in this specification, and, moreover, that a more sharply defined point in the cooling curve is obtained when stirring of the sample is eliminated. The method has therefore been modified by the I.P.T.

2. I.P.T. Standard Method (Serial Designation P.S. 11 a). The apparatus is identical with that of A.S.T.M. except that no stirrer is provided. Molten wax at approximately 15° F above its setting-point is placed in the wax container, the temperature of the surrounding water being kept between 60-80° F throughout the test. Readings of the wax thermometer are taken at 30-second intervals during cooling, and the setting-point is taken as the temperature at which three identical consecutive readings are observed. In cases in which a scale does not give three identical consecutive readings, the determination is to be carried out with the water-jacket temperature 15-20° F below the setting-point of the sample under examination, this procedure effecting a slower rate of cooling.

Many other similar methods have been proposed.

3. The Capillary Method, as commonly used for pure compounds, is not satisfactory, as it depends upon visual observation of the physical state of the wax, and is liable to give erroneous results.

4. Shukoff's Method [21, 1901] consists in shaking 30-40 g of molten wax, enclosed in an air-bath, when it is 5° F above its setting-point, until the contents become turbid and opaque. Following this the temperature is observed at 30-second intervals until identical readings are obtained. The temperature at this point represents the setting-point.

5. A German Method [14, 1927] consists in placing a drop of the molten wax on a surface of warm water and measuring the temperature of the water when solidification of the wax occurs. This temperature is taken to be the setting-point. The method is not practicable as a standard test.

6. A Micro Method proposed by F. Dangle [4, 1931] utilizes a microscope and polarized light. When the wax is molten the field of vision through the microscope is dark.

On solidification of the former the field becomes clear. It is probable, however, that an intermediate stage will exist between the dark and clear fields, and therefore accuracy of the method will be influenced to some extent by the operator

J. Solidification and Plasticity

The range of paraffinic hydrocarbons existing in a wax is an important factor in relation to its suitability for certain applications, for example candle manufacture, in which it may be desirable that wax shall have a limited degree of plasticity, which is attributable in the main to the presence of soft paraffins, otherwise candles may stick in the moulds during manufacture and bend excessively at higher room temperatures during use

1 Fricke [9, 1921] has devised a test which measures in some degree the so-called plasticity, and therefore the suitability of waxes for candle manufacture. 100 g of the wax heated to 65° C are poured into a shallow rectangular pan of specified dimensions, in the middle of which a thermometer is immersed. The room temperature and the time at which the temperature of the wax reaches 60° C are noted. After 50 minutes' natural cooling, the hardness of the wax is tested by means of a loaded metal plunger having a rectangular cross-section of 1 sq cm area, the total applied weight on the surface of the wax being 2.2 kg. If the plunger makes an impression in the wax, when placed 2.5 cm from the edge of the pan, further tests are made at intervals of 2-3 minutes. The time of complete solidification, when the plunger first fails to make an impression which can be seen or felt, is observed. The interval of solidification, from the time at which the wax had a temperature of 60° C to the time of complete solidification as shown by the plunger, is regarded as a measure of the plasticity. The room temperature should be between 17 and 20° C to ensure cooling under constant conditions. Fricke states that for waxes to be suitable for candle manufacture, the solidification interval should not exceed 65 minutes.

This method is one which has not been generally adopted, and it can be criticized on the following grounds

- (a) The effect of varying proportions of oil on the so-called hardness measurement is not analysed or considered
- (b) The temperature control of the cooling cake of wax is crude and likely to lead to anomalous results

2 The rate of softening of paraffin waxes has been investigated with Nasham's 'Malakograph' [1, 1922]. This consists of a balance, to one arm of which is attached a chain with a ball at the end. The other arm of the balance is weighted (heavier than the ball) and so arranged that its vertical movement sets a pen moving over a revolving chart. To operate, the chain is detached from the balance and molten wax is poured into a dish so that it just covers the ball placed centrally in it. When the wax is cold the chain is attached to the balance, and the wax container, on a suitable bath, is heated slowly. As the wax softens the counter-weight on the other arm of the balance slowly falls and the pen describes a curve on the chart. The softer the wax, the steeper will become the curve. It is claimed that curves relating to a given wax are constant and characteristic. This test would appear to be cumbersome and not capable of affording sharp differentiation between waxes.

3 The value of candles is enhanced if they show resistance to bending or plastic flow at elevated temperatures,

and a direct bending test is sometimes employed. The candles to be compared are mounted horizontally with their bases fixed, and placed in an air oven at any required temperature. After a given time the relative amounts of bend are observed. It should be noted, however, that candles generally contain substances other than paraffin, which are added to eliminate 'mottling', to facilitate removal of the candles from the moulds, and to reduce the liability to bend. This test, therefore, is a test of the candle mixture and is quite unrelated to the properties of the paraffin alone.

4 Holde [11, 1902, 12, 1907] describes a method of estimating the amount of soft paraffin in a wax for candles as follows

The wax is first freed from stearic acid by means of alkali. 2 g of the wax are dissolved in 30 c.c. of ether and precipitated with 40 c.c. of alcohol at 20° C. The quantities and melting-point of the precipitated and dissolved paraffin are determined, the latter representing soft paraffin. If the soft paraffin does not contain more than 14% of oil, 0.5 g is dissolved in 100 c.c. alcohol to which 25 c.c. water has been added. The mass is cooled to -20° C and the precipitated paraffin is filtered, washed with cooled alcohol, and dried under vacuum.

The method is a tedious one and probably does not give any more practical information than the simple bending test referred to above.

Although no mention can be found of a simple scientific test for determination of the amount of soft paraffins in a refined wax, or of its width of cut, it would seem probable that a distillation carried out under vacuum in specified apparatus and under standard procedure, followed by an examination of 10% collected fractions (e.g. setting-point), would yield information of value for purposes of comparison, particularly as very small percentages of oil (such as are met with in refined waxes) do not affect the setting-points to any serious degree.

K. Oil in Wax

The important problem of the estimation of the oil in an oil-wax mixture, when the wax predominates, is one which has engaged the attention of many research workers. Numerous methods have been proposed, but they all have disadvantages and limitations, in short, no satisfactory test has been divulged which can be applied with confidence to petroleum waxes generally, whatever their source. The methods available will be described and their limitations noted.

1 I.P.T. Method for Expressible Oil in Scales (Serial Designation P.S. 43). 33 g of the scale are weighed and spread evenly between two tared linen disks to fit the press cup of a hydraulic or lever press. Sufficient filter-papers are placed above and below the disks so that the outer papers shall not be stained by the oil expressed. The whole apparatus and material are kept at 60° F throughout the operation. The paraffin scale and pile of disks are placed in the press cup and a pressure of 9 cwt per sq in is applied for a period of 5 minutes. The pressed scale is then removed and weighed with the two linen cloths. The latter are then separated, scraped free from scale, and weighed. The quantity of expressed oil is obtained by adding together the increase of weight of the cloths and the decrease of weight of the cloths and scale together.

The method, although standardized, has serious objections

- (a) The amount of oil expressed will depend upon the

crystalline structure of the scale, if the latter is finely crystalline, the oil retention in the scale will be a considerable factor and the result will be low. In any case it is impossible to express all the oil from the scale.

(b) If the scale contains much soft paraffin (low melting-point constituents), a considerable proportion of the latter will be expressed in solution in the oil, and the result will be high.

(c) If the oil content of the scale is high, the solution factor of wax in the oil becomes considerable and the result obtained is erroneous.

The test can be applied, therefore, within narrow limits, and in any case the results cannot be of a high degree of accuracy.

Francis and Bennett describe a similar method in which 1,000 lb. pressure is applied to the scale for 5 minutes, and the ASTM has standardized a method in which the same pressure is applied.

There are four principal precipitation methods which are used for the estimation of oil in a wax.

3 Holde's method consists in dissolving the wax (5-10 g) in an excess of ether-alcohol (1:1) mixture at an elevated temperature and cooling to -20°C . The precipitated wax is filtered off at this temperature and washed with cooled alcohol-ether. The process is repeated with the residue, and the combined filtrates are evaporated and the oil weighed. Holde recognizes that even at so low a temperature of precipitation, the wax hydrocarbons are not completely insoluble in the solvent, and suggests corrections depending upon the melting-point of the paraffin present.

For want of a better method, this is the one usually employed, and it can be used with a certain degree of accuracy for scales as well as refined waxes. If the sample to be tested is in any way abnormal in regard to 'width of cut', the method is unreliable. Precipitation methods are generally unsuitable for determination of oil in petroleum cereins, as resinous bodies are precipitated with the wax and render the result too high.

4 Schwarz and Huber [20, 1913] have proposed the use of methyl ethyl ketone in place of ether-alcohol solvent, and claim that the solubility factor of the lower paraffins is considerably reduced by this means. The method is similar to that of Holde, except that only one precipitation is carried out.

It is difficult to substantiate Schwarz and Huber's claim with regard to low melting-point waxes, and it would appear that anomalous differences would still occur when waxes of similar oil content but different 'widths of cut' are dealt with. Other selective solvents have been proposed from time to time, but no solvent is available in which solid paraffins are completely insoluble at any practicable temperature of operation.

5 Wyant and Marsh [24, 1924] have developed a method which, they claim, gives very reliable results. The wax sample is refluxed with pure acetone and allowed to cool to 60°F , when it is thoroughly shaken and filtered, the crystalline mass being washed with acetone at the same temperature. The filtrate is distilled over a steam-bath and finally dried *in vacuo*. The oil is weighed and the wax calculated by difference. The same criticism applies to this as to other precipitation methods. A point in its favour, however, is that the whole operation of precipitation and filtration is carried out at a moderate temperature. It is important that the purity of the acetone be assured, as small proportions of moisture have an enormous effect on its solvent power for both wax and oil.

If the above methods are employed with scales, more than one precipitation is necessary, with consequent transference difficulties.

6 Henderson and Ferris [10, 1927] have proposed a modification of the previous method which eliminates transference of the precipitated wax and in which nitrobenzene replaces acetone as the solvent. The procedure is as follows:

10 g of the sample are weighed into a flask and 20 ml nitrobenzene are added. Air is bubbled through the liquid, and the temperature of the mixture brought to 70°C by means of a hot-air jacket. The mixture is cooled to 32°C and held at that temperature for 5 minutes. The wax floats to the top, the oil-nitrobenzene layer is drawn off, and the procedure is repeated with a second 20 ml of nitrobenzene. Following this, the flask is heated to 135°C and air drawn through it to volatilize entrained nitrobenzene. For removal of final traces of solvent a temperature of 150°C is required. The wax is weighed, and hence the amount of oil in the original sample determined.

The method has convenience and simplicity to recommend it, but whilst oil is more soluble in nitrobenzene than acetone, wax, particularly soft paraffins, also goes into solution at the temperature of extraction.

Refractometric Methods. Freund and Palik [8, 1920] made the observation that if the refractive indices of pure wax and pure oil were known, then the proportion of each in a mixture could be calculated from the sample mixture law. Wilson and Wilkin [23, 1924] adopted the following procedure in the employment of refractive index for oil determination.

5 g of the sample were dissolved in ethylene dichloride and cooled to 0°C , when the mass was filtered. After washing to bring the total filtrate to 150 ml it was evaporated. The solvent-free residue was added to a special solvent consisting of mineral, seal, and ligatura oil of refractive index 1.4470 at 77°F . The assumption is made that the wax left in the solvent extract from the precipitation will have a refractive index of 1.4470 at 70°F , and that therefore any change of the index on admixture with the special solvent will be due to oil alone.

The method is a somewhat complicated one and is open to criticism on the following grounds:

(a) The refractive index of the wax left in the extract will not be constant, but will be dependent upon the 'width of cut' of the original wax.

(b) The refractive index of the wax left in the extract will be dependent upon the initial oil content of the wax as well as the proportion of low melting-point waxes in the original samples.

Diggs and Buchler [5, 1927] observed that when a refined wax containing oil was filtered through Attapulgur clay it reached a state at which further filtration did not affect the refractive index of the filtered wax. They found it possible to filter waxes by this means to a constant refractive index, and the difference of refractive indices of the treated and non-treated wax is due to oil.

Here again objection can be taken to the underlying assumption that the constant refractive index will be comparative for different waxes. Further, it is possible, in some cases, that the filtered wax will still contain oil which is not adsorbed by the clay.

Freund [7, 1930] and Piotrowski and Winkler [17, 1930] reiterate the sample mixture law which applies if the refractive index of the two pure components (wax and oil) are known.

To sum up the limitations of the refractometric methods

1 It is doubtful whether a sensitivity corresponding to 0.5% oil in a wax is attainable, this means of determination being therefore insufficiently accurate for refined wax

2 The principle ultimately depends upon the efficiency of separation of the two components, the difficulty of which has been indicated above

Mechanical Method. The use of the Richardson penetrometer for detection of oil has been proposed by Tokonakov [22, 1929] and Bestuzhev [3, 1931]. A cake of the given sample is cooled to a definite temperature (usually 25°C) and the depth of penetration of a loaded needle which can be released at will is measured. The penetration is read on a calibrated dial. The higher the oil content of the wax, the greater is the penetration of the needle. It is quite clear that this method requires considerable development before serious attention can be paid to it as a quantitative method. For instance, Sakhanov [19, 1931] showed that the type of wax is related to the depth of penetration, and further it is

suggested that the result will be affected by soft paraffins as well as by oil. It is not clear whether different types of oil (in equal percentage) will have the same effect on the result.

In reviewing the numerous attempts which have been made to estimate oil in wax, it is evident that the chief difficulty which still confronts those who seek a satisfactory method is that not only the proportion of oil in wax, but also the proportion of hard and soft paraffins is significant, in other words, there are at least two variants and not only one as has been generally assumed. The methods described fail in varying degrees in the analysis of these variants.

Petroleum Ceresins

There are no specific tests available for petroleum ceresins, and the most reliable guide with regard to their value is obtained from colour measurement in the liquid state and melting-point. To be classed as a ceresin a wax should have a microcrystalline structure and give a hard metallic ring.

REFERENCES

- ANON *Chem Ztg* **46**, 386 (1922)
- BARGMAN, D. *Rev Petr* **570**, 295-6 (1934)
- BESTUZHEV, M. *Erdöl u Teer*, **7**, 301-6 (1931)
- DANGLI, F. *Mikrochem (N S)*, **3**, 333-7 (1931)
- DUDGE, S. H., and BUCHLER, C. *Ind Eng Chem* **19**, 125-7 (1927)
- FRANCIS, C. K., and BENNETT, A. T. *Nat Petr News*, **13** (48), 31-2 (1921)
- FREUND, M. *Petr Z* **15**, 757-8 (1930)
- FREUND, M., and PALIK, G. *Petr Z* **15**, 757-8 (1920)
- FRICKE, K. *Chem Ztg* **45**, 891-2 (1921)
- HENDERSON, L. M., and FERRIS, S. W. *Ind Eng Chem* **19**, 262-4 (1927)
- HOLDE, D. *Mitteilungen*, **20**, 5, 241 (1902)
- *Z angew Chem* **10**, 300, 332 (1907)
- KATARAKIS, C. G., and MEGALALOKOMNAS, J. G. *Chem Zentr* **1**, 1479 (1932)
- KISSER, I. *Zeit wut Mikroskop* **44**, 443-51 (1927)
- MORRIS, F. J., and ADKINS, L. R. *Ind Eng Chem* **19**, 301-2 (1927)
- MYERS, L. D., and STEGEMAN, G. *Ind Eng Chem* **20**, 638-41 (1928)
- PODOWSKI, W. J., and WINKLER, J. *Erdöl u Teer*, **6**, 447-8, 461-5 (1930)
- PYHALA, E. *Petr Z* **18**, 1164-5 (1922)
- SAKHANOV, A. N. *Nat Petr News*, **23**, 16, 49-52, **23**, 17, 67-70 (1931)
- SCHWARZ and HUBER. *Chem Umschau*, **20**, 242 (1913)
- SHUKOFF. *Chem Z* **25**, no 95 (1901)
- TOKONANOV, V. *Neftevaee Khozyarstvo*, **17**, 234-5 (1929)
- WILSON, R. E., and WILKIN, R. E. *Ind Eng Chem* **16**, 9-12 (1924)
- WYANT, L. D., and MARSH, L. C. *U S Bur Mines Rept Investigations*, no 2655 (1924)

TESTING OF ASPHALTIC BITUMEN

By J. S. JACKSON, B.Sc., F.I.C., M Inst P.T.

Shell Marketing Company, Ltd

The testing of asphaltic bitumen presents many peculiar problems. Most of the difficulties encountered with other petroleum products arise in the case of asphaltic bitumen, but with increased intensity.

If accurate repeatable results are to be attained, the product must be handled thoughtfully and almost sympathetically. The long-standing confusion between pitch and asphaltic bitumen and the fact that asphaltic bitumen is a residual product have perhaps conspired to rob this product of some of the respect which is its due.

At the outset the greatest care must be taken to establish and maintain satisfactory temperature conditions. The characteristic properties of asphaltic bitumen are extensively affected by temperature changes, and marked hysteresis effects are encountered.

The thermal history of the sample to be examined must, therefore, be known and studied, and in view of the low conductivity and high viscosity of the product sufficient time must always be allowed for temperature changes to become uniformly established.

Bitumen throughout the ages has enjoyed a remarkable reputation for stability and durability, and it is therefore not surprising to find that it is frequently abused by being seriously overheated. The ill effects of such overheating are serious, and as a guiding principle asphaltic bitumen should never be heated beyond the lowest possible temperature for the purpose in hand.

While a large number of tests are available for the full examination of asphaltic bitumen, a sample can usually be sufficiently defined for routine commercial purposes by the following well-known tests which are fully described in A S T M and I P T publications and need not, therefore, be described in detail.

Softening (Melting) Point

Softening (Melting) Point Ring and Ball. I.P.T. Method A. 20; A.S.T.M. E. 28-36 T. The softening of bituminous materials does not take place at any definite moment or temperature. As the temperature rises asphaltic bitumens gradually and imperceptibly change from brittle or exceedingly viscous materials to softer and less viscous liquids. For this reason the determination of the softening-point must be carried out in accordance with an arbitrary but closely defined method, if the results are to be comparable.

The apparatus consists essentially of a small standard brass ring and a steel ball.

The ring is filled with the bitumen to be tested, supported in a convenient manner, and immersed in water contained in a beaker along with the ball. When the necessary temperature conditions have been established the ball is placed in the centre of the upper surface of the bitumen in the ring.

The temperature is raised at a specified rate. When the softening-point is approached the ball begins to sink into the bitumen, tending to fall through the ring. In a satisfactory test the bitumen will continue to adhere evenly to the ring, while the ball in falling draws down the centre portion. The temperature at which the bitumen has fallen

through a distance of 1 in. is recorded as the 'softening-point'. This temperature is obviously a useful indication of the temperature at which the material can normally be melted, and the softening-point must be taken into consideration in relation to the climatic conditions under which the bitumen is to be used. Whether the bitumen is used as the binder in a road, the coating of a roofing felt, or as a paint, it is essential to have an accurate knowledge of the temperature at which it will soften and begin to flow freely.

In view of its complex nature bitumen cannot be said to have a melting-point in the ordinary sense of the term, and the temperature recorded in accordance with the above procedure is more correctly described as a 'softening-point'.

While the Ring and Ball method is widely used in the United Kingdom, the Kramer and Sarnow method (Holde [3, 1933]) is commonly used on the Continent. The following formula has been suggested to enable the results obtained by the two methods to be compared:

$$R \text{ and } B = 56/54 (K, \text{ and } S) + 7.2^\circ \text{C} \pm 1^\circ \text{C}$$

This formula has been shown to be reasonably accurate for Mexican and Venezuelan bitumens but should not be relied upon for other types of bitumen.

Penetration

Penetration. I.P.T. Method A. 18; A.S.T.M. D 5-25. The penetration can be regarded as the most important test, as commercial grades down to 10 penetration are normally classified according to their penetrations for harder materials melting-point expressed in Centigrade or Fahrenheit is usually employed.

Very briefly the test consists of measuring the depth to which a weighted needle will sink into the sample under carefully controlled conditions.

The bitumen is poured into the penetration tin and brought exactly to 25° C by being immersed in water in a thermostatically controlled bath. The temperature of this bath must be very accurately and uniformly controlled within 0.1° C.

Although penetration is more usually determined at 25° C (77° F) with a load of 100 g acting for 5 seconds, various other conditions of temperature, time, and load are also employed, the most common being those recommended by the A S T M and I P T, which are as follows:

32° F (0° C) with 200 g weight acting for 60 seconds,
115° F (46.1° C) with 50 g weight acting for 5 seconds.

The needle has been closely specified by the A S T M and I P T, and it is most essential that it conforms to the requirements. It is also of great importance to protect the needle against damage or corrosion.

The needle is mounted in the penetrometer and weighted to 100 g.

While being tested the sample is placed under water in a transfer dish. The point of the needle is accurately brought into contact with the surface of the bitumen. The needle is then allowed to fall freely into the bitumen during exactly 5 seconds. The extent of the penetration is recorded on the dial of the instrument in hundredths of a centi-

metre. Thus a bitumen is said to have a penetration of 200 when the needle under a load of 100 g penetrates 20 mm into the sample at 25° C during 5 seconds.

A metronome is usually employed for timing the penetration period, but recently an attractive automatic penetrometer has been designed.

The penetration figure gives a useful measure of the consistency of the bitumen.

In addition to serving as a method of classification, the penetration test is frequently used to determine the susceptibility of asphaltic bitumen to change in consistency with change in temperature. Various formulae have been proposed for calculating the susceptibility factor, and the following are typical.

$$\frac{\text{Pen at } 46^{\circ}\text{C, } 50\text{ g, } 5\text{ sec} - \text{Pen } 0^{\circ}\text{C, } 200\text{ g, } 60\text{ sec}}{\text{Pen } 25^{\circ}\text{C, } 100\text{ g, } 5\text{ sec}}$$

$$\frac{\text{Pen at } 38^{\circ}\text{C, } 100\text{ g, } 5\text{ sec}}{\text{Pen at } 25^{\circ}\text{C, } 100\text{ g, } 5\text{ sec}}$$

The penetration/softening-point relation is also characteristic and may be used for expressing susceptibility.

Ductility

Ductility. I.P.T. Method A. 19: A.S.T.M. D. 113-35. Less importance is now attached to the ductility test than hitherto, but the test is still of importance in that it measures an essential and characteristic property of the product. The ductility of bitumen considered in relation to the softening-point may also provide some indication of the plasticity of the product.

The bitumen is filled into standard moulds with detachable sides. The mould is mounted under water at 25° C in the testing machine and the sides are then detached. The moulds are then stretched mechanically at a rate of 5 cm per minute until the thread of bitumen so formed is broken. The distance stretched without rupture is recorded in centimetres as the ductility of the bitumen.

Loss of Heating. I.P.T. Method A. 17: A.S.T.M. D. 6-33. Since asphaltic bitumens are solid or semi-solid under normal atmospheric conditions and have to be either maintained in a liquid state or rendered fluid prior to use by heating at relatively high temperatures, it is essential that the material shall not contain excessive amounts of constituents which are volatile at average working temperatures. In order to determine the suitability of asphaltic bitumen in this respect, the loss on heating test is applied. This consists essentially in heating a sample of the material at a given temperature and for a given period, and measuring the loss which occurs. The usual consistency tests may then be applied to the residue.

The size of the container, the dimensions, and method of ventilation of the oven, temperature, and period of test are all carefully standardized, and in the I.P.T. and A.S.T.M. methods the sample is heated for 5 hours at a temperature of 163° C. The DIN method differs in the dimensions of the container and in other respects, and gives approximately twice the loss found by the A.S.T.M. and I.P.T. methods.

Viscosity

Greatly increased attention has recently been paid to the viscosity of bitumen. Viscosity determinations are carried out at one or more of the following temperatures: 100° C, 125° C, 150° C, 175° C, and 200° C, using either the Redwood II or the Engler viscometer.

The test is carried out by measuring the time required

for the specified quantity of the material to flow through the jet of the viscometer at the stated temperature. In the case of the Redwood II apparatus the time, in seconds, required for 50 ml of the bitumen to flow through the jet is recorded as the viscosity. With the Engler instrument the time in seconds for 200 ml to flow out is measured and divided by the time required for 200 ml of water at 20° C to flow from the same instrument. The quotient gives the viscosity of the bitumen in Engler degrees.

A knowledge of the viscosity is essential for the proper control of both road-making operations and the various industrial applications of bitumen. Working temperatures must be regulated in relation to the viscosity of the bitumen if coatings of the required thicknesses are to be obtained.

Ash (I.P.T. A. 10) and sulphur (I.P.T. A. 4) determinations are carried out along conventional lines and call for no special comment.

Solubility

Asphaltic bitumens are almost completely soluble in carbon bisulphide, and this test therefore affords a means of determining whether the material has been seriously overheated or contaminated with foreign matter. The test is also used to determine the percentage of asphaltic bitumen present in mixtures of the latter with mineral aggregates.

The presence in asphaltic bitumen of material insoluble in carbon tetrachloride but soluble in carbon bisulphide was formerly considered to be an indication of overheating of the bitumen, but this view no longer meets with general acceptance.

Special significance is attached to the solubility in 60/80 petroleum ether, as this determination gives, by difference, a measure of the asphaltene content. The precise procedure recommended is described in I.P.T. method A. 12.

General

The following standard I.P.T. methods are also available:

- A 13 Asphaltum (soft asphalt)
- A 17 Loss on heating (volatility)
- A 14 Water estimation

The estimation of the wax content of bitumen presents many difficulties, and so far no generally acceptable method has emerged.

Methods depending on the removal of other constituents by sulphonation are 'messy' and inaccurate, whereas those methods which involve distillation are open to the objection that the wax originally present may suffer a variety of changes as the result of the severe heat treatment, and the material finally recovered as crystalline wax may bear little or no relation to the wax constituents originally present in the bitumen.

Oil Content of Bitumen

While the foregoing include all the tests normally used for the examination of asphaltic bitumen, there are a number of methods of an investigational nature which are of interest. Thus a test has been suggested for the estimation of the oil content of bitumen, and the following procedure yields reasonably repeatable results.

30 g of the asphaltic bitumen are dissolved, by heating, in 30 ml of pure benzol in a 500-ml flask. Then 400 ml of 60/80 aromatic free petroleum ether are added, and, after stirring, 30 ml of sulphuric acid of exactly 100%

strength Vigorous shaking for 15 minutes brings about a partial sulphonation, and the mixture is then allowed to settle for some time to allow the acid sludge to settle out. The liquid is then filtered off into a separating funnel and the residual acid sludge in the flask washed two or three times with a total of about 80 ml of petroleum ether, pouring the petroleum ether through the filter into the separating funnel. The solution in the separating funnel is then washed with the following reagents in turn

- (1) 30/50 ml of a 50/50 mixture of water and denatured alcohol
- (2) 30/50 ml of a similar mixture containing about 5 ml of a 2.5% solution of caustic soda
- (3) 30/50 ml of water/alcohol mixture (as above)

The liquid remaining in the separating funnel is then placed in a weighed flask and the solvent distilled off. It is then cooled down to about 100° C in a current of carbon dioxide, and after further cooling, the oil remaining in the flask is weighed.

A knowledge of the oil content is useful in connexion with certain industrial applications of bitumen such as the manufacture of bituminized wrapping-papers, roofing felts, &c. With such materials it is important that oil should not exude from the impregnated materials, otherwise unsightly staining may result.

Emulsions

As considerable quantities of asphaltic bitumen are used for the manufacture of emulsions, it has become essential to have a laboratory test for controlling the emulsifiability of the product. It is desirable to use both a small-scale colloid mill and a paddle mixer to duplicate full-scale operation. For most purposes, however, a small paddle mixer is satisfactory.

A suitable apparatus should be fitted with the following equipment

- (a) A small steam-heated container of known capacity from which the required amount of bitumen can be run into the mixer
- (b) Suitable stirrer and baffles, the stirrer being driven at controlled speed by a suitable motor

Acid Value. In connexion with emulsification experiments it is desirable to have an accurate knowledge of the amount of acidic bodies present in the bitumen.

This determination presents some slight difficulty, but the following method has been found to give accurate results.

5-7 g of asphaltic bitumen are weighed in a 260-ml flask, and warmed with 5 ml of transformer oil (or other suitable light oil of low acid value, e.g. a pale spindle oil) until fluxing is complete. 100 ml of ethyl alcohol are then added and the mixture boiled vigorously for $\frac{1}{2}$ hour under a reflux condenser. It is then cooled and titrated with N/10 aqueous sodium hydroxide solution, 3 ml of a 3% alcoholic solution of Alkali Blue 6B being used as an indicator. In the same way a blank test is carried out, differing from the above only in the omission of the asphaltic bitumen.

The acidity of the bitumen is expressed as an acid value, i.e. the number of milligrams of potassium hydroxide required to neutralize the free acids in 1 g of bitumen.

Olefin Spot Test

In connexion with the detection of overheating of asphaltic bitumens, Oliensis [4, 1933] developed a qualitative test for heterogeneity in asphaltic bitumen. This test,

known as the 'Spot Test', depends on the formation of a dark spot in the centre of a brown circular stain when a drop of a dispersion of the bitumen in 5.1 times its volume of petroleum ether is placed on a filter-paper.

In a recent paper (Oliensis [5, 1936]) the scope of the test has been extended to cover the determination of degree of heterogeneity by addition of xylene in increasing amounts until the dispersion of bitumen no longer gives a positive spot, and also the testing of liquid bitumens. In this latter paper it is stated that heterogeneity, as determined by the Spot Test, may be due to presence of waxy bodies, acid sludge bodies, the combination of incompatible fractions in so-called 'synthetic' bitumens, and exposure to air, in addition to being caused by overheating of the bitumen.

Fraass Test

While penetration and ductility curves over a suitable range of temperatures normally give sufficient information as regards the consistency of the material, the Fraass Breaking-point Test has been used as a means of measuring and comparing the tendency to become brittle at lower temperatures.

The Fraass apparatus (Fig 1) consists of two tubes of non-conductive material, arranged concentrically, so that

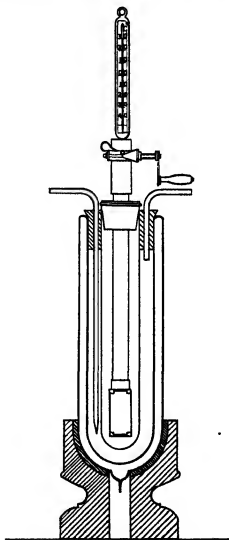

FIG 1 Fraass breaking-point apparatus

TESTING OF ASPHALTIC BITUMEN

the inner tube can move up and down inside the outer Steel clips are fastened to both tubes, so that the movement of the inner tube up and down within the outer alters the distance between the clips The steel plaque, to which the film of asphaltic bitumen to be examined is applied, is held by the clips, and as a result of the movement of the inner tube the plaque is bent from its original position, the asphaltic bitumen film being on the convex surface The movement is controlled by the turning of a handle attached to the instrument, which moves the inner tube by a definite amount

The bending apparatus is supported in a wide test-tube, which is suspended by means of a rubber stopper in an unplated Dewar flask, containing the cooling liquid

This test is used in German specification for Bitumen DIN 1995, but has not been adopted either in Great Britain or the United States for asphaltic bitumens

Float Test

The Float Test ASTM D 139-27 is also valued by many as a convenient means of measuring the tendency to flow The test serves to fill the gap between the viscosity and the penetration limits, and is particularly useful as it is not affected by the presence of resinous material or free carbon

In this connexion the following very simple test often yields valuable information

'L'-shaped tin containers are made 1 in wide and $\frac{1}{2}$ in deep with the limbs 2 in and 2 $\frac{1}{2}$ in long respectively The shorter of the limbs is filled flush with asphaltic bitumen at a temperature 75-100°C above the melting-point, and the containers stood aside to cool They are then placed, with the filled limb vertical, in a location where the temperature can be maintained uniformly at a suitable level The flow of the asphaltic bitumen from the filled into the empty limbs is measured at convenient intervals of time

Recovery of Bitumen

With the above tests available it is obviously possible to obtain a working knowledge of the physical properties and some insight into the chemical nature of an asphaltic bitumen, but those dealing with such products frequently find that in order to apply such tests they must first be able to recover the asphaltic bitumen from various mixtures in which it has been used Any such method must permit of the recovery of the bitumen in such a manner that the properties are only very slightly or not at all affected. D M Wilson [7, 1931-3] has suggested a method for this purpose, but it cannot be claimed that the bitumen is unaffected by this recovery process The following method, which is based on the methods proposed by Suda [6, 1931], Greuter [2, 1932], and Abson [1, 1933], is therefore described, as it is felt it may frequently prove more suitable

Principle of the Method. (a) A dry, representative sample

of the asphaltic bitumen bound material is extracted with carbon bisulphide at room temperature and the solution is decanted and filtered, or centrifuged to remove the mineral aggregate or other insoluble matter present

(b) The asphaltic bitumen is recovered from the solution thus obtained by a regulated vacuum distillation with the aid of a current of carbon dioxide

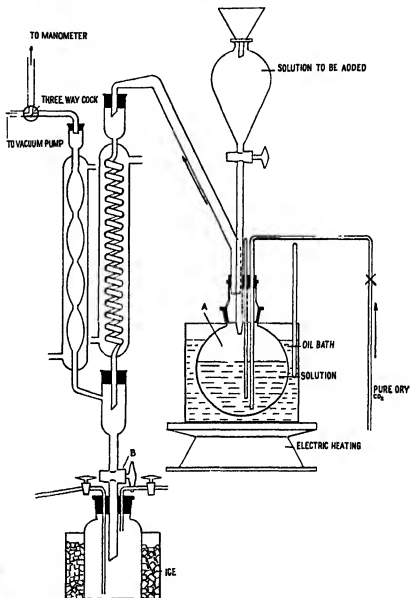

FIG 2 CO₂ vacuum distillation apparatus for the recovery of bitumen from solution.

Apparatus (Fig 2) The distillation flask (A) is supplied with a ground glass stopper provided with an opening for a sealed cork through which the various tubes, as indicated in the sketch, enter the flask

The receiver into which the distilled solvent passes can be separated from the main part of the apparatus so that once the main bulk of the solvent has distilled into the receiver, this is disconnected by a tap (B) (the carbon bisulphide being siphoned off) and the high vacuum necessary for the removal of the last traces of solvent can be maintained without interrupting the distillation

The effective cooling surface necessary for condensation of the vaporized solvent is obtained through two 50-cm. condensers circulated with ice-cold water.

Procedure. A representative portion of the sample is taken, broken up into small pieces, and, if necessary, placed in an oven at 150° C for a short time to remove moisture. The amount of sample taken will depend upon.

- (1) The binder content
- (2) The extent of the examination of the recovered asphaltic bitumen which is required

The dry sample is covered with carbon bisulphide in a beaker and extracted at room temperature. The asphaltic bitumen solution in carbon bisulphide is separated from the mineral aggregate by decantation, filtration, or, when facilities permit, by centrifuging. It is extremely important that the asphaltic bitumen should not remain in solution for any long period before recovery. In general, the recovery should follow immediately, although sometimes it may be necessary to allow the sample to stand in carbon bisulphide overnight.

The solution is introduced into the flask (A) through the dropping funnel, and the temperature of the oil-bath brought to 50° C by means of an electric hot plate. Dry carbon-dioxide gas is then drawn through the apparatus by means of a water-pump. The oil-bath is then brought to 90° C, during which time the carbon bisulphide distils steadily, and by adjusting the stream of carbon dioxide the temperature of the solution in the flask is kept at 20 to 30° C. When most of the solvent has distilled over, further quantities of solution may be added, if required, by means of the dropping funnel without interrupting the distillation, the oil-bath being maintained at 90° C meanwhile.

When most of the carbon bisulphide has distilled, the temperature of the oil-bath is raised to 130° C over a period of 4 to 5 minutes and the water-pump replaced by a mechanical high-vacuum pump. At this stage the contents of the flask frequently froth considerably, but this can be counteracted by careful adjustment of the carbon-dioxide supply. The oil-bath is then brought up to approximately 100° C above the melting-point of the asphaltic bitumen, and when the solvent ceases to distil, the tap (B) is closed and the carbon-dioxide supply cut down very slowly until the pressure is reduced to 7-12 mm. This pressure is maintained during 15 minutes, the temperature of the bitumen being about 100° C above its melting-point.

After this the removal of carbon bisulphide is complete and the asphaltic bitumen is ready for testing.

Liquid

Although liquid bitumens have been in use for many years it is only comparatively recently that the use of these

has become widespread and specifications and methods of testing placed upon a sound basis.

In 1932-3 the Asphalt Institute of America put forward a series of specifications for liquid bituminous materials for surface treatment and road-mix purposes, the tests specified were chiefly those standardized by the A S T M for testing petroleum products. These tests were later examined by a committee of the I P T and adopted with certain modifications. The principal tests now employed are the following:

(i) **Viscosity.** The Asphalt Institute specifies the use of the Saybolt Furol viscometer, Method D 88-30, at temperatures ranging from 77 to 180° F, but in the I P T Method CB 8, the B R T A viscometer has been recommended for use with materials having viscosities between 15 seconds at 25° C and 500 seconds at 40° C, while for materials of lower than 15 seconds viscosity the Redwood No. 2 instrument is used according to method L O 8.

(ii) **Distillation.** A rather arbitrary distillation test has been evolved. This test is a modification of the A S T M method for distillation of bitumen D 20-30 and is now published as A S T M D 402-36, and as the I P T Method CB 3.

This test is designed not only to give useful data concerning the properties of the volatile constituents, but also to give an indication of the nature of the asphalt remaining on the road after evaporation of the volatile constituents, and for the latter purpose one or more of the various consistency tests, such as viscosity, float test, or penetration, may be applied to the distillation residue. Thus the distillation figures, together with the properties of the residue, give useful information of a very practical value.

(iii) **Volatility.** The A S T M and I P T methods of test for loss on heating of asphaltic bitumens are also sometimes used for determining volatility of liquid bitumens, while a further test, known as the Test for Residue of Specified Penetration, which has as its object the determination of the percentage of bitumen of a given penetration obtainable by heating the material under specified conditions, is also used. This test, A S T M D 243-36, consists in heating the material at a temperature of 500° F until the residue has the required penetration, usually 100 at 25° C, and determining the amount of such residue from the difference in weight before and after heating.

(iv) **Flash-point.** The necessary modification of the flash-point determination is described in I P T Test CB 7(r).

So imposing is the above array of tests that it might reasonably be concluded that the whole subject has been thoroughly and systematically explored. Such, however, is not the case, and much work remains to be done towards producing satisfactory methods to measure such fundamental properties as adhesiveness.

REFERENCES

- | | |
|--|--|
| <ol style="list-style-type: none"> 1 AMON, G <i>Proc A S T M</i> 33 (11), 704 (1933) 2 GREUTERT, J <i>J I P T</i> 18, 846 (1932) 3 HOLDES, D <i>Kohlenwasserstoffe u. Fette</i>, 7th ed., p. 408 (Berlin, 1933) | <ol style="list-style-type: none"> 4 OLINBUS <i>Proc A S T M</i> 33 (11), 713 (1933) 5 — <i>Proc A S T M</i> 36 (11), 494 (1936) 6 SUDA <i>Asphalt u. Tar</i> 31, 197 (1931) 7 WILSON, D M <i>J S C I</i> 50, 599 (1931), 52, 579 (1933) |
|--|--|

GENERAL METHODS OF ANALYSIS OF TRANSFORMER OILS

By A. R. STARK, B.Sc., A.I.C., M.Inst.P.T.

Anglo-Iranian Oil Company, Ltd

Of all petroleum products, transformer and switch oils require most careful sampling before analysis if representative results are to be obtained

Tests, which are subsequently to be carried out on samples taken from bulk deliveries, may often result in condemnations if proper care is not taken in sampling. As an instance of this, a sample may be rejected on account of a low dielectric strength because of the presence of minute amounts of water and fibrous material introduced in careless sampling.

Both the British Standards Institution and the American Society of Testing Material have laid down precise instructions for the sampling of transformer oils. These instructions agree on most points, but differ in the materials permitted in the construction of both tins and sample containers.

The A S T M method permits the use of either glass or metal containers, provided, in the case of metal containers, that they shall be constructed with seams soldered on the outside only, and that adequate precautions are taken to remove the last traces of flux.

The B S I method permits the use of glass vessels only. While it may be contended that breakages and upkeep will be heavier with glass vessels, the use of transparent apparatus enables the operator to satisfy himself that his apparatus is absolutely clean, and will also enable contamination to be observed during the actual sampling in cases of much contamination.

Glass sampling apparatus appears, therefore, to be preferred, provided precautions are taken to exclude light from samples, such as referee samples, which may require to be stored for a considerable time before testing.

Both the above bodies pay particular stress on the necessity of avoiding contamination by water and dust, and also on the undesirability of returning excess sample to the bulk which has been sampled.

Dielectric Strength

Since one of the main functions of a transformer oil or switch oil is to act as an insulating medium, particular stress must be laid on the dielectric strength of the oil. In both new and reclaimed transformer oils the most common failures due to loss of dielectric strength are caused by the presence of water and fibrous material, while the presence of large quantities of carbon in switch oils has the same effect.

The presence of water in conjunction with fibrous material has a greater effect than the presence of a like quantity of either component alone would have, since lumps of fibrous particles are apt to occur across parts of the transformer where there is a potential difference, and if these particles contain hygroscopic moisture, flashing over very easily takes place.

As an example of the extent to which water will reduce the dielectric strength of a mineral transformer oil, the following figures are instructive. The tests were carried out on a disk electrode machine of disk diameter 0.5 in. at a distance of 0.2 in. apart.

Water in oil Percentage by volume	Break-down voltage in kv
nil	70
0.005	31
0.01	22
0.02	16
0.03	14
0.04	13
0.05	12.5
0.10	10

In use, oxidation of the oil invariably occurs to some slight extent. This oxidation results in the formation of acids and metallic soaps, which also tend to reduce the break-down strength of the oil. Three types of apparatus are in general use for the determination of dielectric strength. The B S I favours the sphere electrode type, the A S T M uses the disk electrode type, while in the Verband deutscher Elektrotechniker specification No 405, mushroom type electrodes are specified. Since differences in the results obtained by these three methods are to be expected, it is important that the size, type, and distance between the electrodes shall be quoted for each result.

Great care is necessary to ensure that the samples tested shall not be subject to contamination and that the oil cell shall be free from fibrous materials such as might be introduced in drying the cell with filter-paper or cloth. The A S T M advocates the use of calendered tissue paper or dry chamois leather for the primary cleaning of the cell and electrodes, and considers the apparatus to be sufficiently clean when a break-down voltage of not less than 25 kv can be obtained with gasoline.

The B S I removes the last traces of impurities by filling the cup with clean oil and applying about half the test voltage, to attract dust and fibres, and then pouring fresh oil over the electrodes. By repeating this process four times it is claimed that the apparatus will be sufficiently clean for twenty tests, if no mechanical wiping has to be resorted to between tests.

If these preliminary precautions are carried out, the only factors which are likely to affect the results obtained are excessively low temperature and the presence of air bubbles in the sample. The A S T M stipulates a temperature range of 20-30° C, while the B S I stipulates the range from 15 to 20° C. It does appear to be generally agreed, however, that the variable results are almost invariably obtained by carrying out determinations at temperatures lower than 15° C.

In testing used and reclaimed oils, it is important to obtain a sample which shall be representative as regards the impurities present in suspension. Such samples should therefore be thoroughly shaken immediately before introduction into the test cell, and only allowed to stand sufficiently long for air bubbles of size visible to the naked eye to clear from the oil adjacent to the electrodes. If air bubbles are present at the commencement of the test, the break-down voltage of the oil may be considerably lowered by their presence.

A very simple and speedily performed test, designed to detect the presence of moisture, and hence used as a

preliminary to the dielectric strength test, is the B S I Crackle Test. Since contamination with water rarely occurs without slight contamination of other kinds, the presence of crackle is generally indicative of low dielectric strength. This test is more sensitive to traces of water than the normal I P T method of estimation of water, and is therefore to be preferred to the latter in dealing with products which are so adversely affected by small traces of moisture.

Viscosity

A second and important function of a transformer oil is to conduct heat from the transformer. The circulation of the oil in the transformer is therefore of great importance. The oil should not be so viscous at the working temperature that only sluggish circulation can be obtained, and therefore a maximum viscosity at some temperature close to the average working temperature should be specified. A minimum viscosity index might appear to be a useful point of specification in this connexion, but such a point is probably left out in consideration of the fact that such oils as will meet the stringent specifications on other points are of necessity of fairly high viscosity index.

Cold Test

The temperature of partial or complete solidification of the oil is important from this same aspect of imperfection or absence of circulation on starting up under cold conditions. In this connexion the A S T M specifies a pour-point, while the B S I. uses a similar type of test, and also records the initial temperature of separation of solid wax from the oil. This separation of wax at a temperature above the total solidification point of the oil may be a factor of importance in some cases, since the separated layer of solid wax will have a definite retarding effect on the circulation in restricted spaces if the oil has been allowed to remain undisturbed for a considerable period at a temperature intermediate between its cloud- and pour-point.

In the majority of cases, however, the difference in temperature between the cloud- and pour-points of transformer oils is quite small, and it would therefore appear to be quite sound practice to accept an oil on pour-point without reference to its cloud-point.

Acidity and Corrosion Test

The majority of transformer and switch oils are refined partially, if not wholly, with sulphuric acid. In an improperly finished oil there is obviously a risk of the presence of traces of either sulphuric acid itself or sulphonated products remaining in the oil. Such an oil would be corrosive to most metals, especially copper, used in the transformer construction, and considerable damage due to corrosion would undoubtedly occur in any machine in which such an oil was allowed to remain for any length of time at an elevated temperature. It is therefore of paramount importance that transformer and switch oils shall be completely free from inorganic acidity.

Certain types of petroleum, especially those of a naphthenic nature, contain petroleum or naphthenic acids in easily estimatable quantities. These bodies are practically insoluble in water, but do exert a definite corrosive action on such metals as lead, copper, and aluminium on long contact. This corrosive action is greatly accelerated by increase in temperature and the presence of minute quantities of water in which the soaps formed are soluble.

While it is a difficult matter to free an oil absolutely from

petroleum acids, good transformer oils should not contain quantities equivalent to more than 0.1 mg KOH/gm.

Another aspect of the above natural petroleum acidity which is probably less commented upon, but which has a decided bearing upon the performance of transformer oils, is the tendency of oils containing relatively large amounts of petroleum acids to 'go blind', or to hold in stable emulsion small quantities of water with which they come into contact. The A S T M includes in its tests for transformer oils a steam emulsion test, thus obtaining direct evidence on the tendency of oils to form stable emulsions. Whether this test (A S T M D 157) is entirely satisfactory when applied to products of extremely low demulsification value, such as transformer oils, is a debatable point, but it appears to be quite certain that critical interpretation of the results which are obtained will permit of differentiation between samples.

While the above test is easily and repeatedly performed on oils having an S E number of 120 and over, it becomes increasingly difficult to obtain close repeat values as the S E number diminishes. Since at least 10 seconds elapse between the time of starting the stopwatch till the cork and thermometer have been removed from the emulsification tube, it is obviously impossible to record S E numbers of this order. The usual practice is to take readings of separation at 30-second intervals (as stipulated in the I P T version of this test) and to record the S E number as a multiple of 30.

In many cases it is possible to obtain two or more oils of equal S E number according to this interpretation, but which differ in the quantities of 'lacy' emulsion at the oil and water interface, and in the clarity of the oil layer at the conclusion of the test. In assessing relative values in cases of this type, it is therefore suggested that the appearances of the separated oils be taken into consideration, preference being given to that which presents the least 'blind' appearance and shows least 'lacy' emulsion at the conclusion of the test.

Petroleum acids and inorganic acids are not the only potential sources of corrosion in mineral oils. Certain sulphur compounds and elemental sulphur also will cause corrosion of metals with which they are brought into contact, especially at elevated temperatures. Of the commoner metals, copper is most easily and obviously affected by corrosive sulphur compounds. In both the A S T M and B S I methods of estimation of corrosive sulphur compounds, complete immersion tests at practically the same temperatures are specified. The interpretations of the tests are slightly different. The B S I test requires that there shall be absolute freedom from discoloration of the copper, and makes no comment on the likely cause of a discoloration. The A S T M test actually goes farther and acknowledges that it is possible to obtain a discoloured copper strip which has not necessarily been caused by the presence of corrosive sulphur compounds. The stain is therefore dissolved from the strip and the extent of corrosion measured by the precipitation of the sulphide as barium sulphate.

The quantitative nature of this latter test allows of greater differentiation between samples, and it is therefore to be preferred.

Volatility

Since a transformer oil is subject to moderately high temperatures during practically the whole of its useful life, and since also it has an appreciable vapour pressure at the

working temperature, it is obvious that evaporation will be encountered in service. High losses due to evaporation increase the viscosity of the oil, since the more volatile and less viscous fractions are preferentially evaporated. This increase in viscosity causes a more sluggish circulation to be maintained, with a consequently higher working temperature. The cost of maintenance of the transformers may also be greatly increased by the use of a too volatile oil, since transformer oil is a relatively expensive product. An evaporation test is therefore an essential point in any transformer oil specification. Such a test should be carried out at a temperature approximating to the average working temperature of the transformer. The use of too high a temperature might reject, on the grounds of economy, one of two oils of different volatility, but which showed comparable losses in practice, merely because of this difference in volatility. Such a test would therefore be an extremely difficult test to interpret. The BSI test is carried out at 110° C for 5 hours, there being free access of air to the samples, but precautions being taken to ensure freedom from draughts. Since the ratio of surface to volume of oil used in the test is large, it is possible to obtain very much larger losses per unit of time than would be encountered in practice, while maintaining a temperature almost comparable with practice in the test.

A more general type of apparatus for the determination of loss on evaporation is that specified by the ASTM (D 6-33) and the IPT (A 17). In these methods gas heating is employed and the products of combustion, mixed with air, are circulated round the oil samples. These methods are less preferable on account of the difficulty of maintaining such an accurate temperature control as can be obtained by the use of a vapour bath. Provided a suitable temperature is chosen, there appears to be no reason why results comparable with practice should not be obtainable with such an apparatus.

A minimum flash-point is included in most specifications. No special significance should be attached to the results of the flash-point determination. The flash-point is not dependent on the nature or type of the crude oil from which the insulating oil is produced, but on the efficiency of fractionation of the distillation plant on which it was originally produced.

Contamination with low boiling fractions such as gas oil and kerosene results in low flash-point, and such contamination is generally evidenced in the poor results from the other tests performed, if large amounts of contaminants are present.

Volatility cannot be correlated with flash-point, although it is conceivable that in many cases the oil with the lowest flash-point will show the greatest loss on evaporation. Apart from the verification that the flash-point is sufficiently high to obviate normal fire risks in service, the flash-point serves no useful purpose.

Oxidation

The opinion of users and manufacturers of transformers and transformer oils, and of the various Standardization Committees, vary very widely as to the mode of carrying out oxidation tests to imitate, in a short time in the laboratory, the oxidation which will occur in practice.

In this connexion it is interesting to note that an International Standardization Committee has been set up to investigate and interpret various methods of test. The most recent publications of this Committee do not show that any agreement has been reached [2]. It is also noteworthy that

the ASTM has as yet been unable to agree on a satisfactory oxidation test for transformer oils.

In service, transformer oils are subjected to mild oxidation in presence of small quantities of air, at temperatures rarely exceeding 95° C. The products of this oxidation are acids, their metallic soaps, and asphaltic material. Boisselet and Mouratoff [1] conclude from examination of used transformer oils that the acids obtained are mainly saturated cyclic acids with carbonyl groups attached, and also that asphalt is only formed at elevated temperatures presumably higher than the operating temperatures of the transformers.

That asphaltic sludge does develop in transformer oils in service is the view held by most authorities.

In devising a sludge test, therefore, a balance has to be struck between the relative detrimental effects of the two types of oxidation products. Asphaltic material will deposit as sludge in constricted oil passages, thereby reducing convection and heat transfer. These higher local temperatures may cause break-down of the varnish coverings of the insulating materials on the windings. The windings are almost invariably cotton, and are therefore liable to be broken down and have their insulating capacity impaired by the acidic bodies in the oil. It might therefore be concluded that sludge formation was the factor of primary importance in assessing the break-down of transformer oils in practice. The conclusion, however, ignores the possibility of reaction of the varnish medium with the acidic material present, and also assumes that an impervious layer of varnish covers the cotton windings. Probably neither of these assumptions is strictly correct.

In order to demonstrate the diversity of opinion which exists regarding the requirements of an oxidation test, as assigned by a number of leading authorities, the following table is instructive.

Authority	Type of test	Duration (hours)	Catalyst	Temp °C	Constants measured as oxidized oil
British Standards Institute	Aeration under reflux	45	Copper	150	Sludge insol in petroleum spirit Kantling tar value insol in normal benzene
Verband deutscher Elektrotechniker	Passage of oxygen through oil	70	Nil	120	Acid value, cotton breaking strength sludge by centrifuge
Schweizerischer Elektrotechniker-Verein	Exposure to atmosphere	168 and 336	Copper	115	Acid value, cotton breaking strength sludge by centrifuge
Brown, Boven & Cie	"	168	Copper	112	Acid value, insol in benzene cotton breaking
Allmänna Svenska Elektriska Aktiebolaget	"	100	Copper, and iron	100	Acid value, insol in normal benzene Kantling tar value
Official Swedish Specn	Exposure to oxygen	70	Nil	120	Acid value, insol in normal benzene Kantling tar value

It will be observed, firstly, that the temperature chosen by the BSI is considerably higher than that of any of the other authorities, and that sludge insoluble in petroleum spirit is the only criterion considered. Two grades of oil are specified by this authority, the A grade which is suitable for use in transformers where the working temperature exceeds 80° C and has a specified maximum of 0.1% sludge, and the B grade, where a maximum of 0.8% is allowed.

An exceptionally highly refined oil is necessary to meet the A specification, and almost invariably these oils

develop a much higher acidity in an oxidation test than the B class oils. Since the temperature of oxidation chosen is probably 50-60° C higher than will be encountered in practice, sludge may be shown in the laboratory test in a short time, and yet never appear in practice, because of the lower temperatures occurring.

The extent to which alterations in results can be obtained by performing the B S I test in the normal manner and at the average temperature of the other tests quoted above is demonstrated in the following table

B.S.I. classification of oil	Temperature of test	% Sludge formation	Acidity formation mg KOH/gm
A 30	150	0.04%	3.1
	110	negligible	2.4
B 30	150	0.75%	1.9
	110	negligible	0.3

Thus at 110° C, a temperature still above average service conditions, no differentiation is obtained in sludge formation between two typical A and B class oils. It will be observed that in these tests the B class oil is shown to develop less acidity at both temperatures. It is therefore obvious that if these two oils, which are typical of the two classes, were listed by such methods as the S E V and B B & C methods, which employ a lower temperature than the B S I test, allow a comparatively large asphalt formation, but place a low limit on acidity formation, then there would be a great tendency for the A class oils to be rejected and the B class oils to be accepted.

This is a very anomalous situation, calculated to cause much inconvenience to suppliers of transformer oils.

The B S I test would probably be subject to less criticism if the temperature were reduced to between 100 and 120° C and oxygenation used in preference to aeration. Under these conditions it is probable that differentiation on sludge formation could still be obtained between samples in the present duration of the test, and that these sludge values would be more comparable with the development of acidity.

The determination of acidity development as measured by the acid value of the oxidized oil is also open to criticism in such tests as the S E V, B B & C, and A S A E tests. Some of the acidic bodies formed are of much lower molecular weight than the oils from which they are formed, and are volatile at the temperature of the test. The acid values reported are therefore not truly representative of the total acid formation, although accurate relative results are obtainable between samples.

In the S E V and B B & C tests an attempt is made to measure the acidity formation in terms of acids which have a direct corrosive effect on cotton thread as used in the transformer windings. Standard thread is subjected to the action of these acids in the course of the test and the deterioration of the strength of the thread measured. Since the determination of the acid value of an oil by the normal methods is not among the most accurate of analytical determinations, this thread test appears to have much to commend it. Against this it is frequently argued that the cotton windings of the modern transformer are not sub-

jected to the action of acid oil, since they are invariably varnish coated. It is highly improbable, however, that a continuous and unbroken film of varnish remains on the transformer windings throughout their useful life.

In the V D E test the acidic and saponifiable resinous bodies are isolated by Kisslings alkali and subsequent acidification, the quantity of material extractable being reported as the tar value. This method is tedious and requires careful manipulation, but is accurate and commendable.

In all the above tests when an asphalt determination is made by a precipitation method, some type of petroleum solvent is used. The B S I, for instance, allows the use of a fairly wide cut fraction of boiling range 60-120° C with a low aromatic content, while the others use normal benzene.

The use of such solvents, which are a mixture of hydrocarbons, both paraffinic and naphthenic, leaves much to be desired. Since they are generally prepared by acid washing petroleum distillates followed by neutralization and redistillation, it follows that quite a number of chemically different precipitants of the same boiling range and aromatic content can be obtained which will give very different asphalt contents on the same oil sample. This is well illustrated in the following table.

Precipitant	I P T per ether	Continental samples of normal benzene				Di-ethyl ether
		1	2	3	4	
Asphalt content on sample No 1	0.96	0.41				0.62
Asphalt content on sample No 2	1.02	0.46	0.52	0.58	0.48	0.65

It has therefore been suggested that di-ethyl ether, an easily obtainable pure chemical compound, should be used in the place of the petroleum precipitants. The results obtained with ether are, on the whole, higher than those obtained with the petroleum fractions of a naphthenic nature, but lower than those obtained with paraffinic precipitants. Alterations in the specification limits could be made to counteract this.

From a summary of the above accelerated oxidation tests it should be possible to evolve an International Standard, bearing in mind the following points. The temperature should be only sufficiently above 100° C to exclude the presence of water, the acceleration being obtained through the use of oxygen and such a catalyst as copper. During oxidation reflux should be provided to avoid large loss by evaporation. A measure of both the acid and sludge development should be obtained.

In a report published (April 1935) by the International Electrotechnical Commission Advisory Committee No 10 on Insulating Oils [3], results of oxidation tests are given in terms of the Anderson Asia Test, with and without an applied electrical field. One of the conclusions reached is that 100° C is undoubtedly the highest permissible test temperature for oxidation tests for transformer oils.

REFERENCES

- 1 BOBBLETT, L., and MOURATOFF, C. *Ann Comb Liq* 19, 9, 69 (1934)
- 2 WEISS, H., and SALOMON, T. *Proc World Petr Cong* 2, 421 (1933)
- 3 Report on Comparative Tests on Oils, comprising Service Tests,

Different Ageing Tests, and other Tests for investigating the General Qualities of Three Transformer Oils of different degrees of Refinement, but prepared from the Same Crude. International Electrotechnical Commission Advisory Committee No 10 on Insulating Oils (April 1935)

CABLE OILS

By C CHILVERS, B.Sc., F.I.C.
Anglo-American Oil Company Ltd

General.

THE properties required in a cable oil depend, naturally, on the type of cable in question and on the voltage for which it is designed. Essentially, medium and high voltage cables consist of one or three conductors each wrapped with oil-impregnated paper, the whole being protected by means of a lead sheath. Manufacturers do not agree as to the best type of impregnating material. One of the most common impregnating compounds for solid-filled cables is a blend of mineral oil and rosin, some 16 to 30% of the latter being used, while recently experiments have been made with specially purified rosin, rosin distillates, and abietic acid in place of rosin.

Straight mineral oil has its advantages, however, while blends of this with petrolatum are also employed for the lower voltage cables.

It is necessary that the compound should have the properties of a lubricant so that the layers of paper will slide over each other when the cable is handled. Chemically, the oil must be free from acid, but opinion is divided upon certain of the physical properties required. In general, it is stated that the oil should have a sufficiently low viscosity at the impregnating temperature (about 240° F) to ensure easy and complete impregnation, while at low temperatures the viscosity must be high enough to prevent flow to lower levels when the cable is laid on an incline and to prevent excessive draining when the cable is cut for jointing, &c.

Vertical cables, e.g. in mine shafts, present special problems in this connexion, as any tendency to flow to the bottom may cause sufficient pressure to burst the lead sheath. Since, however, the voltage involved is usually quite low (about 600 volts), insulating material of inferior electrical properties to mineral oil may be used, and bitumen-filled cables are commonly employed for this purpose.

It is usually stated that the oil must not set at the lowest temperature to which the cable will be subjected in service, or voids may be formed which facilitate ionization and ultimate break-down. Nevertheless, certain blends used for impregnation are set at normal temperatures, e.g. blends of mineral oil (which itself is fluid at low temperatures) with petrolatum.

These requirements have led to a demand in some quarters for oils of low viscosity index. Certain naphthenic base oils with this characteristic show good electrical properties, while they are also reported to have a greater solubility for rosin than have the paraffin base oils. On the other hand, many manufacturers maintain that refined oils of the latter type give better results in service, and for high-tension cables, e.g. 33,000 and 66,000 volts, cylinder oils of Redwood viscosities at 140° F and 200° F of about 600 sec (= 680 sec Saybolt = 150 cs) and 150 sec (= 170 sec Saybolt = 36.5 cs) respectively are used. For lower voltage cables, oils of Redwood viscosities at 140° F and 200° F, in the region of 380 sec and 95 sec respectively are frequently used.

It is, of course, necessary that the heat generated by the passage of the current through the conductor shall be dissipated from the latter as quickly as possible, and since it

is claimed that the main thermal conductivity of an oil-impregnated cable is due to the oil, it is desirable that the thermal resistivity of the oil should be as low as possible. Different oils, however, do not vary much in this respect among themselves, and obtaining a cable of low thermal resistivity is mainly a question of efficient impregnation.

Mineral oils have a relatively high coefficient of expansion, and since the temperature of a solid-filled cable may rise in service to 50 or 60° C, there is a comparatively high pressure developed in the cable due to the tendency of the compound to expand. As a result the lead sheath itself may be stretched. The latter will not again contract on cooling, so that a void is formed which may rapidly become gas filled with ultimate break-down of the cable. No chemical or physical treatment will appreciably affect the coefficient of expansion, so that a number of mechanical devices are adopted to overcome this difficulty.

The problem, however, is important, and a number of specially designed cables have been evolved with a view to accommodating for the expansion of the impregnating medium. Special mention is made of the Pirelli hollow-core cable, as the oil used, which in this case is always a straight mineral oil, is of a different type to that employed for solid-filled cables. In these cables the conductor is wound on a spiral metal tube, then being paper wrapped, &c., and lead sheathed as in the above type of cable. The impregnating medium in this case, however, is a comparatively thin oil (viscosity at 40° C 60-80 sec Redwood (= 68-90 sec Saybolt = 12.5-18.5 cs), at 20° C 125-185 sec Redwood (= 140-210 sec Saybolt = 30-45 cs)). The oil at present used for these cables is rather less highly refined than the oil originally specified, as it has been found that the tendency to form gas under electric stress is greater with the more highly refined product.

The cable is impregnated as usual, the tube being filled with oil. When the cable is laid, the tube is connected at intervals to pressure tanks containing the oil, so that the dielectric of the cable is continuously under a slight pressure of oil. (The tube is a loose spiral so that oil can pass through it.) When the temperature rises and the oil expands it is forced back into the tanks from which it again re-enters the cable as the temperature falls. The highest voltage cables, single-core cables of 132,000 and 66,000 volts, are of this type, but there are also three-core cables of 66,000 and 33,000 volts in which three oil ducts separate from the conductors are provided.

Properties of Cable Oils

The usual physical tests, e.g. specific gravity, viscosity, flash-point, cold test, &c., are, in general, insufficient to predict the relative merits of particular mineral oils intended for use as dielectrics in electric cables. In addition to the above tests, therefore, the following electrical properties of the oil are measured:

- 1 Power factor
- 2 Resistivity,
- 3 Specific inductive capacity
- 4 Break-down voltage

It is also the practice of certain cable manufacturers to apply tests after subjecting the oil to some accelerated ageing process, intended to indicate the ability of the oil to withstand drastic service conditions

Definitions.

1 Power Factor. The system of conductors and dielectrics forming an electric cable may be conveniently regarded as a condenser. In a perfect condenser subjected to alternating voltage (e.g. when the dielectric is a vacuum), the current leads the voltage by 90° and no power is dissipated. Since, however, no dielectric is actually perfect, some power loss occurs, the current no longer leading by 90° but by a slightly smaller angle ($90 - \delta$), where δ is termed the 'loss angle' of the dielectric as it is independent of the form of the condenser. The departure from true quadrature is a measure of the imperfection of the dielectric.

If I and V are the effective current and voltage respectively, and θ or ($90 - \delta$) the angle by which the current leads the voltage, it can be shown that the power loss = $IV \cos \theta$, i.e. this expression represents the power dissipated in a condenser subjected to alternating voltage, and $\cos \theta$ is the power factor. In other words, power factor is given by the ratio of true watts (actual power loss) to apparent power (i.e. volts \times amperes).

With straight mineral oil the power factor decreases as the temperature falls, and the normal procedure is to measure the power factor over a temperature range usually from about 85 to 20°C .

2 Resistivity. The resistivity of a material is the resistance between opposite faces of a centimetre cube. When a dielectric is subjected to a steady difference of potential, there is, at first, a rush of current which gradually dies away, usually approaching asymptotically a steady finite value, which, with high-class dielectrics, is extremely small. Until this approximately constant value is reached, the resistance obviously varies with the time of application of the voltage. As it is not normally practicable to wait until this constant value is reached, it is the general practice to measure the resistivity 1 min. after the application of the voltage.

The resistivity increases as the temperature falls, and measurements are normally made over the same temperature range as for power factor, i.e. 85 to 20°C .

3 Specific Inductive Capacity (SIC) The Specific Inductive Capacity or Dielectric Constant is a measure of the amount of energy a dielectric can support. It is a definite property of the substance depending on the conditions within the atom. The SIC is usually defined as the ratio of the capacity of a condenser with the given substance as dielectric to the capacity of the same condenser with air (or more accurately a vacuum) as the dielectric. For all solid and liquid dielectrics the SIC is therefore greater than 1. For mineral oils the SIC rises slightly as the temperature falls.

4 Break-down Voltage, or Dielectric Strength. This is the maximum voltage which can be applied between specified electrodes immersed in the oil under specified conditions, without the occurrence of a continuous arc. In practice, this test is not always applied to cable oils as it is of less significance than the above-mentioned tests. It is more an indication of the freedom of the oil from suspended impurities and moisture, rather than a criterion of the insulating properties of the oil, and cable oils are, of course, filtered and dried before use.

Apparatus and Methods of Test

No standard electrical tests have yet been approved (apart from the BSI break-down voltage apparatus), but the ASTM has under consideration tests for power factor, resistivity, and SIC on cable oils.

For all electrical tests it is essential that the sample of oil should be free from suspended impurities and from moisture. Before testing, therefore, the oil is filtered through fine gauze and then heated to $100-110^\circ\text{C}$ under vacuum for 30-60 min. to eliminate all moisture.

Power Factor and SIC are determined at the same time. One type of apparatus will be described in which the test is made using 1,000 volts and 50 cycles. Essentially, this apparatus consists of a Wheatstone bridge, in one arm of which the oil is placed in a condenser. This is balanced against a standard variable condenser by means of ratio resistance arms, one of which has a variable condenser connected in parallel to compensate for the phase difference caused by the power loss in the oil. A vibration galvanometer, which can be tuned to the frequency of the supply by altering the current through the field of the galvanometer, is used as detector.

The circuit is roughly as in Fig 1.

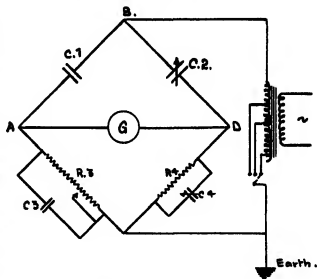

FIG 1

- C_1 is the condenser containing the oil
 - C_2 the standard variable condenser by which the capacity of C_1 is balanced
 - C_3 is the variable condenser which accommodates for the phase difference and therefore the power loss
 - R_1 is a fixed resistance
 - R_2 a resistance which can be given any of three values to enable a balance to be obtained if the SIC of the material is very high
 - C_4 is a condenser of low capacity to balance out stray capacities and enable a zero reading to be obtained on C_1
 - G is the vibration galvanometer, the field of which is controlled by a 12-volt battery and a suitable variable resistance
- A reversing switch is also incorporated in the circuit. The HT supply is from the mains and passes to a transformer giving an output of 50, 250, and 1,000 volts

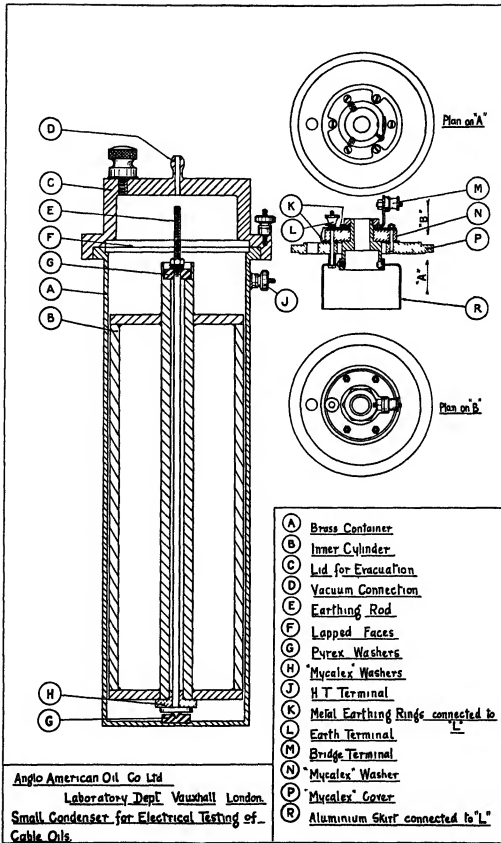

FIG 2

It can be shown that when the bridge is balanced, the power factor is given by

$$\frac{\omega(C_4 R_4)}{10^6}$$

Since $\omega = 2\pi f$, this expression becomes

$$\frac{2\pi f C_4 R_4}{10^6} \text{ (where } f \text{ is frequency of supply)}$$

When $f = 50$, R_4 is made = $\frac{5,000}{\pi}$

Then the power factor = $\frac{C_4}{2}$

Thus the power factor is obtained directly from the reading of C_4 . Actually, C_4 shows a slight positive reading when the pot is empty. This has to be subtracted from the reading of C_4 when the pot is full of oil. (This correction is of the order 0.0001.)

The Specific Inductive Capacity is given by the ratio of the capacity of condenser C_3 when the bridge is balanced with C_1 full of oil, to the capacity at balance with C_1 empty.

The most commonly used oil condenser with this type of apparatus consists of a tall cylindrical vessel of nickel-plated brass, requiring about 300 ml of oil for the test (see Fig 2). Inside this, but insulated from it at the bottom by a small pyrex glass washer, fits an enclosed concentric cylinder, the clearance at the sides being about 3/64ths of an inch. This cylinder is automatically centred by means of an accurately fitting mycalex cover, so that the gap is maintained constant.

In this case the outer vessel itself serves as one plate of the condenser and the inner cylinder as the other. Suitable precautions are taken against leakage both at the surface of the oil (which is about $\frac{1}{4}$ in above the top of the central cylinder) and at the junction of the latter and the glass washer at the bottom. Actually two types of cylinder are supplied, in one the contact with the insulating washer at the bottom is guarded, while in the other, which is for routine testing, the cylinder is solid and no arrangement is made for guarding at this point. An additional metal cover is provided with a suitable orifice to enable vacuum to be applied. This condenser is heated by some suitable means (e.g. by an electrically heated oil-bath, the temperature of which is controlled and measured). Since the voltage is applied to the condenser, it is necessary to insulate the latter from the metal oil-bath, while the bath itself, together with the metal stirrer, heater, &c., are all earthed. The electrical capacity of this condenser is about 0.0005 microfarad.

Using 1,000 volts, 50 cycles, a.c., the bridge is balanced with the pot empty, and the readings of C_3 and C_4 noted. The oil is then introduced and the pot heated to 100–110°C. Vacuum is applied for 30–60 min., the temperature being maintained. Measurements of power factor and S I C are then made by balancing the bridge at intervals as the temperature falls, noting the readings of C_3 and C_4 in each case.

For Resistivity determinations the same condenser is used, but a different circuit is required as measurements are made with d.c. The method used is the simple one of substitution. It consists in noting the current flowing 1 min after the application of the voltage to the container, filled with oil. The pot is then replaced by a standard megohm and a variable resistance adjusted until the same current flows through the circuit. (In practice, the deflexion of a galvanometer is used as an indication of the current flowing.)

One circuit may be roughly represented as in Fig. 3.

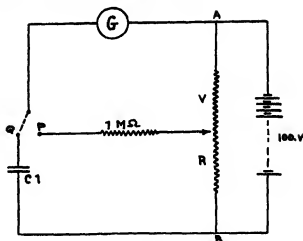

FIG 3

The pressure (usually 100–500 volts) is applied from dry batteries across AB and with the galvanometer (G) connected to the test condenser (C_1) through Q , the reading of the galvanometer after 1 min is noted. The connexion is then switched to P (the standard megohm) and with a convenient value of R (which can be varied from 10,000 to 100,000), V is adjusted until the deflexion of the galvanometer corresponds to the reading previously obtained.

It can be shown that the resistance of the oil in the container equals

$$\frac{R+V}{V} \text{ megohms}$$

Then the resistance per cm³ equals

$$\frac{R+V}{V} \times \frac{A}{d} \left(\frac{\text{area of plates}}{\text{distance between them}} \right)$$

If the capacity of the empty pot is K microfarads,

$$\text{the capacity} = K \times 9 \times 10^6 \text{ electrostatic units} \\ = A/4\pi d$$

Hence

$$\frac{A}{d} = 4\pi K \times 9 \times 10^6$$

And resistivity = $\frac{R+V}{V} \times (4\pi K \times 9 \times 10^6)$

$$= \frac{R+V}{V} \times 1,131 \times 10^6 \times K$$

When V is small compared with R , $\frac{R+V}{V} = \frac{R}{V}$,

and then resistivity = $\frac{R}{V} \times 1,131 \times 10^6 \times K$ megohms

Resistivity measurements are made on the dried oil as the temperature falls immediately succeeding each determination of power factor and S I C. The electrical apparatus required for the two measurements (a.c. and d.c.) may be mounted conveniently in one unit so that all that is required is to change over the leads.

In each case power factor, S I C, and resistivity curves are constructed showing the relationship between these properties and temperature over the range 85–20°C. As the temperature falls, power factor falls and resistivity rises. Some relationship appears to exist between these two properties. A high power factor corresponds to a low resistivity and vice versa. In the case of different oils of the same type, if the oils are arranged in descending order of power factor, this order is the ascending order of resistivity.

The extreme variation in S.I.C. is quite small, about 2.1 to 2.4, and the S I C / temperature relationship is approximately linear for straight mineral oils

Break-down Voltage.

The apparatus for this test is that described in British Standard Specification 148, 1933. It consists of a glass containing-vessel with spherical brass electrodes—13 mm diameter arranged horizontally, 4 mm apart. The oil-level is 2 in. above the electrodes.

Alternating voltage (50 cycles) is applied to the electrodes and gradually increased. The break-down voltage is generally taken as the maximum voltage which the oil withstands for 1 min without break-down. Tests are made at room temperature, but, as stated above, this test is not, in general, used for cable oils.

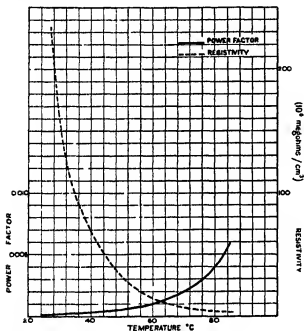

FIG 4

It is necessary, then, that a cable oil shall show a low power factor, high resistivity, and high break-down value, while at the same time it is preferable that the S I C shall be low, but, as mentioned above, the extreme variation in S I C with different mineral oils is comparatively small, so that less significance is attached to this test.

Although an oil may show satisfactory power factor, resistivity, and S I C, however, it does not necessarily follow that this oil will prove satisfactory in service. Oils vary considerably in their ability to withstand service conditions, and with a view to obtaining some indication of the behaviour of an oil in practice, a number of accelerated ageing tests have been brought forward. Generally speaking, these tests have been devised by cable manufacturers to suit their individual needs, and as a result the tests vary greatly and there is little evidence available as to the degree of correlation of any particular test with service conditions.

On heating in air, oils show a deterioration in electrical properties, i.e. power factor is raised and resistivity lowered, the effect varying with the origin and degree of refining of

the oil. Most of the ageing tests are based on this fact, but no such test can be regarded as satisfactory because, in actual practice, the oil is rarely exposed to air either in the initial drying or during impregnation. Similarly, the finished cable should be quite free from air so that, in

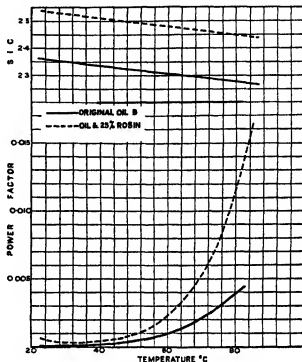

FIG 5

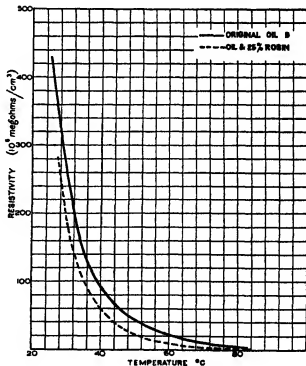

FIG 6

service, oxidation can play little or no part in any deterioration which may occur

Some manufacturers have also had under consideration tests in which oil is subjected to high electrical stress, but no satisfactory test has yet been evolved on these lines

Fig 4 gives typical power factor and resistivity curves for a modern high-tension cable oil

Fig 5 gives power factor and S I C curves for another cable oil before and after adding 25% rosin

Fig 6 gives the corresponding resistivity curves for the same oil and blend as in Fig 5

It will be noted that the power-factor curve of the rosin blend shows a pronounced minimum This is characteristic of these blends

SELECTED BIBLIOGRAPHY

- ATKINSON, R W, and SIMMONS, D M Oil-filled Cable and Accessories *Trans Amer Inst Electr Eng* 50, 1421 (1931)
- DUNSEATH, P *High Voltage Cables* (Isaac Pitman & Sons, 1929)
- EMANUELL, L *High Voltage Cables* (Chapman & Hall, 1929)
- HARTSHORN, L Critical Résumé of Recent Work on Dielectrics *J Inst Electr Eng* 64, 1152 (1926)
- JACKSON, W Résumé on Recent Work on the Anomalous Behaviour of Dielectric Liquids *J Inst Electr Eng* 75, 93 (1934)
- MACKEY, G M J Some Physical and Chemical Characteristics of Electrical Insulation *Can Chem and Met* 15, 215 (1931)
- PIPER, J D, THOMAS, D E F, and SMITH, C C Liquid Dielectrics *Ind Eng Chem* 28, 309 (1936)
- RACE, H Changes in Physical and Electrical Properties of a Mineral Insulating Oil heated in contact with Air *J Phys Chem* 36, 1928 (1932)
- RACE, H H Some Electrical Characteristics of Cable Oils *J Amer Inst Electr Eng* 50, 673 (1931)
- Reports of High Tension Conferences* (Paris, 1931, 1933, and 1935)
- RILFV, T N, and SCOTT, T R Insulating Oils for High Voltage Cables *J Inst Electr Eng* 66, 805 (1928)
- SHANKLIN, G B, and BULLER, F H Characteristics of Oil-filled Cable *Trans Amer Inst Electr Eng* 50, 1411 (1931)
- WHITEPAD, J B Conductivity of Insulating Oils, I and II *Trans Amer Inst Electr Eng* 49, 647 (1930), 50, 692 (1931)

THE ANALYSIS OF GREASES AND HIGH-PRESSURE LUBRICANTS

By C. A. FOSLER

Assistant Chief Chemist, Bohn Aluminum and Brass Corporation

The development of the machine age has been accomplished largely through the science of lubrication. The designer of bearings and gears for modern machinery requires the co-operation not only of the metallurgist, but also of the lubrication engineer. Recognition is given to the fact that the metals composing the rubbing surfaces and the lubricant supplying the protective film are of equal importance to the successful operation and long life of the moving parts. Indeed, since failure of the film usually precedes failure of the metal, we may consider the lubricant of primary importance.

CLASSES OF LUBRICANTS

Specialized lubrication has vastly increased the variety of lubricants on the market at present. Greases alone range in consistency from thin liquids to solid blocks, in colour, from transparent, stainless greases for textile and baking machinery to heavy black residuum greases for external cables and gears, chemically, the metallic, fatty, and mineral oil components are of many kinds and combinations.

(a) Extreme pressure lubricants, containing substances normally present or added for the purpose of preventing seizure under conditions of critical pressure, include many different classes. A few of these are

- Fatty oils and derivatives
- Mineral oils containing fatty oils
- Sulphurized mineral oils
- Sulphurized compounded oils
- Sulphur chloride lubricants
- Lead-soap lubricants (with or without sulphur)

(b) The principal kinds of greases in general use are made from mineral oil thickened with various soaps of the following metals

Sodium	Lead
Calcium	Potassium
Aluminum	Zinc

Oils thickened with residuum, petrolatum, or wax are sometimes classed as greases. Flake graphite is added to greases used for spring leaves and certain gears, deflocculated graphite is used in oils where a permanent suspension is demanded, although electrolytes, i.e. acids, bases, or salts, will cause precipitation of the suspensoid. Mica, soapstone, and other mild abrasives are rarely added except in greases for use at very slow speeds and high pressures.

IMPORTANCE OF ANALYSIS

The large consumer of lubricants, such as the automobile manufacturer, inspects incoming shipments of these materials as rigidly as he tests his receipts of steel and other materials of construction. The proper lubricant is specified for each application and is subject to critical laboratory analysis before acceptance. Certainly bearings and gears may be perfect in design, construction, and finish,

and yet be short-lived if the lubricant does not provide a satisfactory film at all temperatures of operation. Should an abrasive or corrosive substance be present, the destruction will be further accelerated.

SCOPE OF THE SUBJECT

The analysis of lubricants may well be divided into the following sections

- I Preliminary Examination
- II Physical Tests
- III Chemical Analysis

I. Preliminary Examination

(a) **Stability** Valuable information may frequently be obtained from the appearance of the material when the container is opened. Evidence of separation, bleeding (of greases), stratification, discoloration, or lumpiness—all indicative of improper manufacture or instability—may be detected at this time. An excessive water content may be revealed upon kneading with a spatula. Obviously, the most desirable lubricant is one of homogeneous composition, which remains unaltered during storage.

(b) **Colour.** Since a mineral oil, in most cases, constitutes the major portion of the lubricant, the colour of the product is markedly influenced by the type of hydrocarbon oil. Pale spindle, engine, bright stock, cylinder, or residuum oils may generally be recognized. However, it must be noted that oil-soluble dyes are sometimes added to greases to improve the colour. Fluorescence or bloom, readily observed by placing a few drops of the oil on a blackened glass plate, is characteristic of mineral oils. Deblooming agents, e.g. nitro-naphthalene, are occasionally used in compounded oils.

(c) **Odour.** Lubricants containing ingredients of good quality should not have an offensive odour. The presence of deodorants, e.g. nitrobenzene, should be viewed with suspicion, in their absence the kind of fatty oil used may sometimes be detected. In this way it is possible to distinguish tallow, lard, rosin, pine, neatsfoot, or fish oils.

(d) **Texture.** In many greases, particularly in those with a calcium soap base, water acts as the emulsifying agent. Evaporation of the water therefore breaks the emulsion, and separation usually occurs. In a stable emulsion, where water acts as the disperse phase and is distributed or suspended through the grease in very minute droplets of high-surface tension, the surface forces between the oil and water interface are necessarily in equilibrium. A prolonged temperature near the melting-point may cause these droplets to coalesce and thus destroy the stability of the emulsion.

The texture of greases may be smooth, buttery, ropy or stringy, spongy, fibrous, or rubbery.

Sodium greases exhibit wide variation in texture, they may be smooth, ropy, or fibrous, these variations are occasioned by differences both in composition and in

methods of manufacture. Sponginess is related to the glycerine and water content.

Calcium, calcium-magnesium, and calcium-sodium greases are ordinarily smooth or buttery.

Aluminum greases also differ widely in structure. In addition to the diverse textures shown by the above types of greases they may appear rubbery or elastic, crumbly or as a firm jelly. Greases of this type, however, are more susceptible to alteration in temperature than other greases. In particular, aluminum stearate greases containing mineral oils of low viscosity lose their jelly-like structure upon heating and become stringy. Rapid cooling from a moderately high temperature (275° F) results in a granular material. Another unusual circumstance peculiar to aluminum greases is that the softer, stringy greases contain a higher viscosity mineral oil than the hard jelly-like ones.

Lead greases are usually liquid.

Potassium greases are soft and generally contain considerable glycerine.

Zinc greases are mainly pharmaceutical preparations, although zinc stearate is supposed to be a superior lubricant.

Sampling. Before proceeding with the physical and chemical testing of the lubricant, the analyst is urged to exercise the greatest care in sampling. A representative sample must be obtained in all cases. The quantity should be sufficient to permit a complete analysis without resampling. Frequent and thorough mixing is necessary.

II. Physical Tests

For the liquid lubricants there are many standard physical tests which are valuable for purposes of identification, for greases very few such tests are available. Technical Paper No. 323-B [13, 1927] prepared by the Bureau of Mines gives these methods in detail.

Carefully controlled service tests are necessary in order to demonstrate conclusively the superior qualities of any lubricant. The various laboratory tests may then be applied to obtain sufficient data from which a specification may be written and subsequent purchases of the product thereby controlled. In substance, most of our modern mechanisms have reached their present state of development by following this identical procedure with respect to the various materials of construction.

A brief description of methods of physical tests pertaining directly to E P lubricants and greases follows.

(a) **Specific Gravity.** A set of narrow-range standardized hydrometers offers the most rapid means of obtaining the gravity of the various liquid lubricants, for limited quantities of oil, small 6-in hydrometers are available.

The Westphal balance, equipped with a water-bath capable of adjustment for constant temperature, may be used for determinations at elevated temperatures.

For solid materials which remain homogeneous upon melting, determinations at the temperature of boiling water are conveniently made, using the specific gravity bottle or the Sprengel pycnometer.

Temperature corrections and conversion of specific gravity readings to A P I degrees may be accomplished by consulting the National Standard Petroleum Oil Tables, B S Circular No. 154 (1924) [21].

In testing extremely small quantities of oil, the alcohol flotation method, in which the alcohol is diluted until a drop of the oil or fat remains suspended in it, may be used.

The gravity of the alcohol solution is then taken with the hydrometer. Obviously, the oil must not be soluble in the alcohol.

(b) **Viscosity.** For this determination, the Saybolt Universal or Saybolt Furoil viscosimeter has been standardized under A S T M Method D 88-33 [2].

For heavy transmission oils, oils thickened with soap, and for low-temperature viscosities the pressure viscosimeter such as described by C M Larson [19, 1931] has found considerable application.

In working with the separated oils from greases, where it is convenient to extract small amounts, capillary viscosimeters, e g the Ostwald, Bingham, or Vogel-Ossag, are decidedly preferable, since 10 to 15 ml of oil suffice for a series of determinations at different temperatures. The Vogel-Ossag has proved very satisfactory in operation and may be used for kinematic viscosity determinations without the pressure (600 mm water, i e 0.0589 atm) apparatus, which is required in all these instruments for measurements of absolute viscosity.

Kinematic viscosities may be expressed in centistokes as the product of the time of outflow in seconds and the capillary coefficient. This unit is advantageous, since it is not necessary to ascertain the density in order to convert values in centistokes to times of outflow in seconds for standard commercial viscosimeters, such as Saybolt, Redwood, or Engler.

In the regime of fluid film lubrication, viscosity is undoubtedly the most important physical property of the liquid lubricants.

Under these conditions, in a plain journal bearing the coefficient of friction has been established by a number of investigators as a function of

$$\frac{\text{viscosity (Z)} \times \text{rate of shear (N)}}{\text{unit load (P)}}$$

Viscosity is largely the basis for classification of E P lubricants as well as crank-case oils.

The temperature-viscosity relationship of an oil is customarily expressed by the Dean and Davis viscosity-index, in which system two oils of widely different viscosity-temperature characteristics were used as a base. One, a Texas base oil, has an index of 0, while the other, a Pennsylvania base oil, has a 100 viscosity index. Thus the higher the index the lower the susceptibility to temperature change. These numbers therefore indicate the relative paraffinic or asphaltic character of the oils, Mid-Continent or mixed base oils having indices of approximately 60 to 70.

The predominating importance of the viscosity of the mineral oil in greases has been shown by M H Arveson [1, 1932].

A rapid method for the estimation of the viscosity of the hydrocarbon oils in greases has been described by C A Fosler [14, 1932].

(c) **Consistency.** (A S T M D 217-33 T I P T—LG 18) A study of the lubrication of ball and roller bearings has shown a definite relation between consistency and initial torque. Measurements of consistency, however, have not been entirely satisfactory, since not only temperatures and time are of influence, but also the extent of working.

The penetrometer is useful as a control test for all greases except those of too soft consistency (i e more than 36 0 mm penetration of the cone), additional weights may be attached to the plunger in testing very hard greases.

In the use of the grease worker, specified as an accessory

to the method for penetration of greases and petrolatum, it will be found that the recommended 60 strokes of the plunger may not be sufficient to effect complete break-down of the structure in all types of greases

Even in greases containing the same metallic base and similar amounts of soap, water, and mineral oil of the same type and viscosity, it has been shown that while one grease reaches a condition of apparently stable consistency by the cone penetrometer after 60 double strokes, the other may require several hundred strokes. Further indications are that rate of change of structure of greases may be modified by differences in the kind of fatty material, the method of manufacture, i.e. whether milled cold or cooked, and the rate of cooling.

E. R. Lederer and E. W. Zublin [20, 1933] describe a falling weight method for the consistency control of soft and string greases, particularly transparent semi-liquid aluminum greases, by a comparison of the time required for a metal ball to drop through a tube of the material. This test is supplemented by the use of the A. S. T. M. penetrometer for measuring the string characteristics of the grease. R. Bulkey and F. G. Binter in Bureau of Standards Research Paper, No. 188 [11, 1930], obtain the flow-pressure diagram of greases at various temperatures and of oils at low temperatures by means of a capillary-tube consistometer. The effect of working on the break-down of structure is illustrated.

Although the performance of lubricants in service may be predicted to some degree from static consistency tests, more complete information may unquestionably be obtained from a test device involving the use of a typical bearing properly housed so that temperature control of all the significant parts may be maintained at any point within the probable service range. Starting torque, frictional and break-down characteristics, and the effects of centrifugal force (e.g. channelling) under measured applications of speed, load, and clearance should all be allowable of observation and study. The design must be such that reproducibility of results is attainable.

A number of such instruments of the torsion type are in use. The principle is fundamentally that of the Prony brake. Power consumption may be calculated by means of the well-known formula

$$HP = \frac{2\pi WR}{33,000}$$

where W = force which holds the brake from turning,

r = common radius of the rubbing surfaces,

R = revolutions per minute,

$2\pi R$ = angular velocity

The consistency of greases and the viscosity or internal friction of oils are obviously closely related to torque or power consumption. This unit is therefore a measure of the frictional losses and heat generation due to the viscosity or consistency of the lubricant.

(d) Other tests which furnish data from which conclusions can be drawn concerning the composition of the material are

1. **Precipitation Number** (A. S. T. M. D 91-33) [3]. This is the number of millilitres of precipitate formed when 10 ml of the lubricating oil are mixed with 90 ml of petroleum naphtha of definite quality and centrifuged under definitely prescribed conditions.

The precipitate here may contain the following

Asphaltic compounds insoluble in the specified solvent.

Free sulphur

Insoluble soaps

Sodium chloride or sulphate

Graphite or other fillers

Metallic particles or metallic oxides

2. **Water and Sediment** (A. S. T. M. D 96-30) [5]. A 50 ml sample and 50 ml benzol are mixed at 120° F and centrifuged in the specified manner. Most of the asphaltic material is soluble in the benzol, and any sediment obtained by centrifuging may for purposes of further examination be purified by repeated treatment with fresh benzol.

Identification of this material is frequently of great significance. Treatment with CS_2 will remove traces of asphalt or sulphur. A magnet is used for iron or steel particles. A microscopic examination at low magnification (up to 100x) will show the character of vegetable or animal fibres, or crystalline compounds. Particle size, shape, and hardness will determine the degree of abrasiveness. The conclusions may be verified by chemical and spectroscopic analysis.

When the amount of sediment is small, it is sometimes customary in technical analysis to transfer it from the centrifuge tube by means of ether or benzol to a weighed crucible, in which the material is burned to an ash and reported as per cent of non-combustible sediment.

3. **Corrosion Test**. A clean strip of mechanically polished pure sheet copper is submerged in the test material, which is then maintained for 3 hours at 212° F.

Discoloration or pitting indicates corrosion, which may be due to free acid. Free sulphur causes a rapid darkening of the copper. The copper strip may be weighed before and after the treatment if quantitative results are desired.

Other metals of construction may be used similarly to the copper, either singly or together.

The efficiency of most E. P. lubricants depends upon their controlled chemical activity, initiated at dangerously high pressures by thermal action, whereby the affinity of certain compounds in the lubricant for the metal surfaces produces over a limited area a friction-reducing film, which prevents seizure or welding.

Thus a laboratory test for corrosiveness of a lubricant should simulate as closely as possible the particular application for which the lubricant is intended.

These conditions involve the kinds of metals of which the reciprocating parts are constructed, the range of temperature, extent of pressure or vacuum, degree of aeration, amount of moisture, frequency of film removal by rubbing, &c.

Types of corrosive compounds in these oils other than compounds formed by the action of sulphur and chlorine on unsaturated or double-bond hydrocarbons and terpenes are naphthenic acids (present in nearly all hydrocarbon lubricating oils), which attack the metals to form soaps, soluble in the oil and increasing its viscosity, fatty acids, present or formed by oxidation (action of enzymes or bacteria) in all animal and vegetable fats and oils.

4. **Carbon Residue** (A. S. T. M. D 189-30) [8]. Ten grams of the oil are evaporated in a weighed porcelain crucible without access to air under specified conditions of time and temperature. The weight of the carbon residue is a rough indication (40%) of the asphaltum content of residuum oils, according to some investigators. Asphalts are formed through polymerization and oxidation of the unsaturated hydrocarbons or terpene-like constituents of the oil. These reactions may occur in the automobile transmission especially in the presence of metallic oxides, if

polymerization centres are present in the oil. Very pronounced increases in the viscosity of residuum oils have at times been observed. Such viscous products may be almost insoluble in the naphtha used in the test for precipitation number.

III. Chemical Analysis

(a) Types of Lubricants.

Extreme pressure lubricants and greases submitted for analysis usually fall under one of the following types

- 1 Straight mineral oils, including oils thickened by means of wax, petrolatum, or asphalt
- 2 Straight vegetable oils, such as castor, rape, or olive
- 3 Straight animal oils, such as lard, tallow, neatfoot (including liquid waxes such as sperm oil)
- 4 Compounded oils—mixtures of type 1 with animal or vegetable oils or fats
- 5 Mineral oils containing either added chlorine or sulphur (or both)
- 6 Compounded oils containing either added chlorine or sulphur (or both)
- 7 Greases—oils such as types 1, 4, 5, or 6 thickened with soap
- 8 Oils or greases containing graphite or mild abrasives (meca, talc, soapstone, or gypsum)

This list is by no means complete, but it serves to point out the complexity of the mixtures which may confront the analyst.

Analytical difficulties may be further complicated by the occasional presence of impurities such as sodium chloride or sand in residuum oils and greases, iron oxide from stills, metals in colloidal solution, metallic soaps or naphthenates in small amounts accidentally accumulated as the end products of corrosion, siliceous residues from various materials of manufacture (e.g. from lime or caustic used in greases), and phosphorus introduced in the form of calcium or magnesium phosphates in bone fat or as lecithin in various fats and oils.

Oils removed from transmission or differential gear cases, or greases taken from bearing housings, after a period of use, may have altered very materially with respect to oxidized, gummy, or acidic compounds, and in addition may contain water, metallic particles, and dirt of various kinds.

Blown oils, in which the constants of the original oil have undergone very considerable changes, are correspondingly more difficult to identify. Oxidation increases the density, viscosity, acidity, saponification, and acetyl values of the oil. The iodine value is decreased.

(b) Methods of Analysis.

Under Preliminary Examination (Section I) and Physical Tests (Section II) the appearance and behaviour of the material will have given information concerning its nature.

An attempt is made to list the succeeding chemical tests in the order of their relative importance for these types of lubricants

- 1 Total Sulphur
- 2 Added Sulphur—if total sulphur is appreciable
- 3 Free Acid and Alkali.
- 4 Ash
- 5 Fillers—including Abrasives

- 6 Soap—if Ash is appreciable
- 7 Total Fatty Oil
- 8 Petroleum Oil and Unsaponifiable Matter
- 9 Saponification Value
- 10 Constants of Fatty Acids
- 11 Chlorine
- 12 Water

1 Total Sulphur

A Qualitative. The following sensitive test is recommended. Five to ten drops of the oil are added to molten sodium metal in a Pyrex test-tube and the heat gradually increased to redness. The cooled melt is cautiously leached out with 10 ml of water, filtered into a test-tube of special form, acidified with HCl in small excess, boiled, and the vapours allowed to react with lead acetate paper. F. W. Lane and J. W. Devine in Bureau of Mines Res. Inst. 2828 [18] state that sulphur in any form as low as 0.02 to 0.03% will give a distinct darkening of the paper.

B Quantitative. The bomb method A. S. T. M. D. 129-34 is rapid and accurate. The bomb lining should be resistant to sulphuric and nitric acids. The high nickel-chromium alloys fulfil this requirement. No oxidizing agent such as ammonium nitrate is required.

Procedure. A 0.6 to 0.8 g sample is weighed into the sample container, placed in position, 20 ml of water added to the bomb, and the bomb tightly closed. Oxygen is slowly admitted until the gauge pressure reads from 25 to 40 atm, according to the bomb capacity (300-500 ml). The highest recommended pressure will give the best result. After firing, let stand 10 min., release the residual oxygen slowly, wash contents of bomb into a beaker. Filter into a 250-ml beaker, wash paper, add 2 ml conc. HCl, 10 ml sat. BaCl₂ solution (10%) from a fine-tipped pipette to the boiling solution while stirring. Allow to boil 5 min., let stand hot 1 hour, filter and wash until washings are free from chloride. Ignite and weigh.

$$\text{Per cent sulphur} = \frac{\text{g BaSO}_4 \times 13.734}{\text{g oil used}}$$

If the lubricant contains lead, PbSO₄ will be formed in the bomb. In this event the contents should be boiled with saturated Na₂CO₃ which converts the PbSO₄ to soluble Na₂SO₄ and insoluble PbCO₃. The alkaline Na₂SO₄ solution is filtered, washed, acidified, and treated according to the method above.

The amount of total sulphur in a lubricant is not a criterion of its E.P. properties, since some oils contain over 3% sulphur so firmly combined that no corrosion can be effected at the temperatures of operation.

2. Added Sulphur

A Qualitative. A polished copper strip immersed in the lubricant at 212° F will show as little as 0.10% elementary sulphur after a very short contact period.

B Quantitative. The following method has been approved for use in the Cadillac Motor Car Company laboratories.

The method is based upon the selective action of nascent hydrogen on certain reactive sulphur components of the lubricant, absorption of the evolved H₂S in ammoniacal CdCl₂ solution, decomposition of the CdS, and titration of the H₂S by means of standard iodine solution.

Apparatus. The apparatus consists of a reaction flask, a trap, and an absorption tower. The first two sections are 500-ml. wide-mouth Erlenmeyer flasks. The gas is neutral-

ized in a Milligan absorption tower, which is shielded from bright light with a black paper cylinder during the reaction period

The reaction flask has a 3-hole rubber stopper. Through the centre hole a 150-ml separatory funnel extends about 2 m below the stopper with the tip directly over a 25-ml Gooch crucible supported in a ring formed on the lower end of a glass rod passed through another hole in the stopper. The delivery tube from the third hole leads to the bottom of the trap, likewise a 500-ml Erlenmeyer flask, which is then connected to the Milligan absorption tower.

Solutions and Reagents

Granulated zinc	10- and 40-mesh
Conc HCl	sp gr 1.19
Dil HCl (1 l)	
CdCl ₂ solution	478 ml H ₂ O 522 ml NH ₄ OH (sp gr 0.9) 13 g CdCl ₂

Starch Solution Mix 12 g of starch with about 50 ml water and make up to 200 ml with boiling water

Standard Iodine Solution 1 ml = 0.0003 g S

Solution A Dissolve 0.6 g KMnO₄ in 100 ml water

Solution B Dissolve 8.5 g KI in 200 ml water and add 25 ml H₂SO₄ (1.3)

Pour solution A slowly into solution B while mixing continuously. Dilute to 1 litre

This solution is approximately 0.01872 N (1 ml = 0.06% S on a 0.5-g sample of oil) and may be standardized against Na₂S₂O₃ solution of the same normality (4.6463 g Na₂S₂O₃ · 5H₂O per litre). The latter solution may be conveniently standardized against a p. resublimed iodine crystals, using somewhat less than 0.1 g. One millilitre of the Na₂S₂O₃ solution should equal 0.002376 g iodine. The blank to be subtracted from each titration will vary according to the intensity of the blue colour adopted as a satisfactory end-point by the individual operator. The magnitude of the blank is determined by running a test exactly according to the method, using a sample of oil containing no added sulphur.

Procedure Fill the Gooch crucible level full with 10-mesh Zn. Pour half this Zn into the reaction flask and add enough 40-mesh Zn to make the crucible two-thirds full. A round disk of filter-paper is fitted to cover the Zn, and about 0.5 g of the oil to be tested is dropped on the disk from a weighing bottle.

Thirty-five millilitres of the ammoniacal CdCl₂ and 90 ml distilled H₂O are placed in the Milligan tower, which is connected to the trap. With all connexions and stoppers tight, the funnel is filled with conc HCl and the acid allowed to drop very slowly on the sample in the crucible. The acid is added drop by drop at a rate which will consume all the acid in about 2½ to 3 hours, occasionally turning the crucible by means of the glass support rod so that the acid will fall upon different parts of the disk. When the reaction is complete, withdraw the separatory funnel and replace with a glass tube of same dimensions as funnel stem. The lower end of the tube is immersed in the acid solution. The outlet tube of the absorption tower is now connected to a vacuum line and the train is flushed with air for a few minutes to absorb completely all traces of H₂S.

The contents of the absorption tower are next washed into a 400-ml beaker containing 10 ml starch indicator and the solution diluted to about 250 ml. About two-thirds

of the anticipated amount of the iodine solution is now added, followed by 50 ml 1.1 HCl, and the titration completed as rapidly as possible, maintaining an excess of the iodine at the surface until near the end-point to avoid any loss of H₂S. When a permanent blue colour is attained, pour the titrated solution back into the Milligan tower, agitate, again transfer to the beaker, and continue the titration. Repeat this procedure until all the CdS adhering to the absorption tower has been decomposed and titrated. Very satisfactory results have been obtained by this method.

The sulphur found here is believed to have a close connexion with those sulphur compounds which control the E.P. property of lubricants of this type. On the other hand, sulphur compounds which are corrosive at low temperatures are very undesirable except for certain applications. Reaction of the film with the metal over areas of extreme pressure only is the effect the compounder strives to achieve.

3. Free Acid and Alkali

A Mineral Acid and Free Alkali. A large portion (25 to 50 g) of the oil is shaken in a separatory funnel with 100 ml of boiling distilled water, followed by two more extractions, using 50-ml portions of water. The 200 ml. of water are tested first with 1 drop of 1% phenolphthalein solution for free alkali. A pink colour indicates alkali, which is estimated by titration with a standard solution of sulphuric acid (0.08913 normal).

$$\text{The alkali neutralization number is} \\ \frac{(\text{ml of acid}) \times 5}{\text{wt of oil}}$$

If alkali is not indicated, 2 drops of 0.1% methyl orange solution are added. A red colour shows mineral acid, which is determined by titration with standard aqueous potassium hydroxide solution (0.08913 normal).

The separated water after extraction may be filtered before making the above tests.

$$\text{The mineral acid neut. number is} \\ \frac{(\text{ml of alkali}) \times 5}{\text{wt of oil}}$$

B Free Acid in Straight Mineral Oils. To a 20-g sample in a 500-ml Erlenmeyer flask add 100 ml of a hot mixture of 1:1 neutralized alcohol and distilled water. Agitate and heat to boiling. Add 1 ml of phenolphthalein indicator (1%) and titrate to a pink end-point with standard aqueous KOH as above. The colour change is observed in the bottom layer after allowing a moment for separation.

$$\text{The neutralization number is} \\ \frac{(\text{ml of alkali}) \times 5}{\text{wt of oil}}$$

With some oils a 2% alcoholic solution of alkali blue makes a better indicator.

This test is important in crank-case lubricating oils, which in service may develop acids of low molecular weight, such as formic or acetic, which are very corrosive. Saturated acids of higher molecular weight become increasingly less acidic, and the highest ones may be considered harmless.

C. Free Acid (total) in Compounded Petroleum Products and Animal and Vegetable Fats and Oils. Since the acidity may be high, it is necessary to take for analysis a quantity of the sample corresponding to the probable acidity. A 10-g portion is usually sufficient.

In some cases 0.5 N KOH is preferable instead of the weaker solution. Use 50 ml of neutralized alcohol as the solvent and titrate hot. For some oils a better solvent is a mixture of 60 ml benzol with 30 ml alcohol, using alkali blue as the indicator. A homogeneous solution results and the colour change is seen by transmitted light.

In determining the acidity of dark compounded oils containing sulphur a solvent mixture of 25 ml benzol with 100 ml neutralized 1:1 alcohol has been recommended.

The neutralization number or the acid value is
mg KOH required to neutralize 1 g of oil,
or the acid value is

$$\frac{\text{ml KOH} \times (56.1 \times \text{normality of sol})}{\text{wt of sample}}$$

The acid value $\times 0.5032$ equals % oleic acid

If the mean molecular weight of the mixed free fatty acids is known, the

$$\text{per cent fatty acid is} \\ \text{acid value} \times \frac{\text{molecular weight}}{561}$$

Example Suppose 10 g of oil required 35.42 ml 0.5 N KOH

Then the acid value is

$$\frac{35.42 \times 28.05}{10} = 99.35$$

Per cent acid (if oleic) is

$$99.35 \times \frac{282.27}{561} = 49.99$$

Per cent acid (if stearic) is

$$99.35 \times \frac{284.29}{561} = 50.34$$

Per cent acid (if palmitic) is

$$99.35 \times \frac{256.26}{561} = 45.36$$

D Free Alkali and Free Acid in Greases. The following is abstracted from A.S.T.M. Method of Analysis of Grease (D 128-27) [6]. From 10 to 30 g of grease contained in a 150-ml beaker are thoroughly mixed with 75 ml of petroleum ether. The mixture is washed into a 250-ml flask with ether and 50 ml of 50% alcohol, a few drops of phenolphthalein added, and the whole vigorously shaken. If the alcohol layer is pink, 10 ml of 0.5 N HCl are added, the solution boiled 10 min to eliminate CO₂, and the excess HCl titrated with standard 0.5 N alcoholic KOH. The free alkali is calculated as the hydroxide of the principal base, found by analysis of the ash.

If the original alcohol layer is not pink, the cold solution is titrated with 0.5 N alcoholic KOH and the acidity calculated as oleic acid.

Marcusson [17, 1922] advises heating 10 g of the grease under a reflux condenser with a 90 ml mixture of naphtha absolute alcohol, filtering off any insoluble matter, adding 30 ml neutral 50% alcohol, heating and titrating with 0.1 N alcoholic NaOH.

The factors required are

1 ml 0.5 N HCl equals	0.01853 g Ca(OH) ₂
1 ml " "	0.02000 g NaOH
1 ml " "	0.02806 g KOH
1 ml " "	0.01458 g Mg(OH) ₂
1 ml 0.5 N KOH "	0.14113 g oleic acid
1 ml 0.1 N NaOH "	0.02823 g oleic acid

The acid value may be calculated as in method 'C'

4. Ash.

Pure hydrocarbon or fatty oils, with the exception of bone fat, should, upon ignition, leave no weighable ash. Commercial oils, however, invariably contain inorganic matter, varying from mere traces in the light oils to as much as 0.10% in the dark cylinder or residuum oils. An ash content in excess of 0.10% is evidence of faulty refining, careless handling, or the deliberate addition of soap or fillers.

For this reason a residue of ash is our most valuable indication of the presence of soap or other additive material in the oil. This is especially true, since in dark residuum oils which emulsify we are unable to test for small amounts of soap by the removal of the metallic radical with HCl and subsequent evaporation of the acid extract to dryness.

Procedure. A weighed sample of 5 to 100 g, depending upon the consistency and texture of the material, contained in a porcelain casserole is carefully burned to carbon-free ash. If sodium or potassium are present the porcelain may be attacked. Therefore, if lead or other easily reducible elements are known to be absent, a platinum dish is preferable. The weight of the residue is reported as *percentage of ash*.

Instead of weighing the ash as above, it may be treated with a small amount of water, H₂SO₄ in slight excess added, the solution evaporated and fumed, and the residue ignited at a red heat. The residue is then weighed and reported as *per cent of ash as sulphates*.

If the ash is high and the presence of combined fatty acids is not confirmed (see III (b) 7), metals, metallic oxides, siliceous matter, and various inorganic salts may be the source. Soaps are therefore absent and the methods of identification under II (d) 1 and 2 or III (b) 5 should be followed.

Examination of the Ash.

A Qualitative. A trace of Fe₂O₃ is to be expected, an alkaline residue indicates Na, K, Ca, or Mg, Na and K residues are fusible and water-soluble, Ca, infusible and but slightly water-soluble, Mg, infusible and only slightly soluble unless sulphate is present, a white infusible ash, neutral and practically insoluble in acids, shows Al₂O₃, evidence of the probable addition of aluminum stearate or oleate, i.e. dope or oil pulp. A neutral ash containing alkali or alkaline earth metals does not necessarily denote the absence of soaps of these metals, since high sulphur oils thickened in this manner usually burn to a neutral residue of sulphates. Flame, bead, or spectroscopic tests may be used for a qualitative examination of the ash.

B Quantitative. The recommended practice of estimating the amount of the alkaline base such as Na, K, or Ca by a direct titration of the ash is thus perceived to be unreliable, since all of the Na or K is rarely present as the carbonate, neither does all of the Ca originally combined with the organic radical appear as pure CaO in the residue. Soap percentages calculated from data derived in this way are almost always erroneous.

By following a prescribed scheme of quantitative analysis the proportions of the various basic constituents may be established. Subsequent to the determination of the combined fatty acids, if present, these data may be correlated to express the percentages of the various soaps. In this connexion it should be noted that any free alkali found under III (b) 3d should be deducted from the total alkali found in the ash (e.g. in a Ca soap grease any free Ca(OH)₂ should be calculated to CaO and subtracted from the CaO determined in the ash), since for this purpose we are concerned only with the amount of base combined as soap in the original material. This likewise holds true for lead and aluminium oxides existing in the free condition in greases containing soaps of these metals.

Analysis of the Ash.

If the standard alternative method for the ash determination is used, in which the residue is converted to the sulphates, the analysis may proceed as follows.

The weight of the ash as sulphates is first obtained. In a good-quality light cup grease made from Ca soap the ash may contain, besides CaSO₄, minor amounts of MgSO₄, Na₂SO₄, Fe₂O₃, Al₂O₃, and SiO₂, and perhaps traces of other metallic oxides.

Dissolve the ash in 10 ml conc HCl, adding water gradually, and boil to dissolve all soluble salts. Filter off the SiO₂, wash, ignite, and weigh. The filtrate is treated with H₂S to eliminate any Cu, Pb, and metals of that group. If lead is suspected, the acidity should be adjusted to about 3% conc HCl for this precipitation. Filter if necessary, boil off H₂S, oxidize the Fe with a few drops of HNO₃, and make barely ammoniacal (excluding any CO₂ which would precipitate Ca) to methyl red. Boil a moment and filter. If the bulk of the precipitate is large, reprecipitate. The influence on the composition of this precipitate due to the possible presence of phosphate must be determined. Wash, ignite, and weigh Al₂O₃ and Fe₂O₃. This residue may be fused with KHSO₄, dissolved, the Fe titrated, calculated to the oxide, and deducted from the weight of the mixed oxides to obtain the weight of the Al₂O₃.

To the filtrate from the Fe(OH)₃ and Al(OH)₃ add a slight excess of (NH₄)₂C₂O₄ at the boiling-point. Boil until the CaC₂O₄ becomes granular, allow to settle, and test with the reagent for complete precipitation of Ca. Filter, wash, ignite, and weigh as CaO. If desired, the CaC₂O₄ precipitate in the filter-paper may be decomposed in a hot dilute H₂SO₄ solution and the liberated H₂C₂O₄ titrated with standard KMnO₄ solution.

The above filtrate is acidified with HCl, evaporated to 100–150 ml volume, made very cold, and 20 ml sat (NH₄)₂HPO₄ added. Add NH₄OH dropwise with vigorous stirring until about a 15-ml excess is present. If the solution has been stirred for 15 min, it may safely be filtered after standing cold 4 hours. Wash thoroughly with 5% NH₄OH containing 5% NH₄NO₃. Ignite and weigh as Mg₂P₂O₇.

For a proximate analysis of the ash, calculate CaO and MgO to CaSO₄ and MgSO₄ respectively. To the sum of these add the amount of Fe₂O₃, Al₂O₃, SiO₂, and subtract this sum from the total weight of the ash as sulphates. The difference, if supported by a qualitative identification, may be considered Na₂SO₄ from which the amount of Na₂O may be calculated.

The factors required are

Fe	1 ml 0.05 N KMnO ₄	equals	0.00279 g Fe
Ca	1 ml	„	0.00140 g CaO

Ca	CaO	× 2.428	equals	CaSO ₄
Mg	Mg ₂ P ₂ O ₇	× 0.3621	„	MgO
Mg	MgO	× 2.986	„	MgSO ₄
Na	Na ₂ SO ₄	× 0.4364	„	Na ₂ O

Lead may be estimated by careful ignition of a 0.5 to 1.0 g sample mixed with an excess of Na₂CO₃, followed by solution in dilute HNO₃, filtration, and electrolysis in the presence of copper nitrate. Any residues must be leached out with saturated Na₂CO₃ or 20% NH₄C₂H₃O₂ in hot solution to safeguard against loss of PbSO₄.

Zinc is precipitated as ZnS, after removal of the H₂S group and the trivalent hydroxides as described above, in a 0.01 N H₂SO₄ solution (or formic acid), dissolved in HCl and estimated gravimetrically as the phosphate or volumetrically with K₄Fe(CN)₆.

Lime may appear in small amounts in soda-soap greases, since in the soap manufacture it is added to caustic soda solutions to convert alkali carbonate to hydroxide. Ca and Mg mostly sludge out as insoluble CaCO₃ and Mg(OH)₂.

Magnesium is to be expected in Ca soap greases, since MgO is invariably found as an impurity in quicklime used in soap-making.

Phosphorus should always be determined in a separate sample, since volatilization may occur from a H₂SO₄ or KHSO₄ fuming, furthermore, Ca₃(PO₄)₂ mixed with SiO₂, CaCO₃, or Na₂CO₃, and carbonaceous matter, may at high temperatures break down into P₂O₅, which is reduced by the carbon to volatile elemental phosphorus.

The calculation of the soap content of the lubricant is based upon the amounts of the various metals in combination with the fatty acid radical, and the factors involved will be exemplified under the heading 'Soap' (III) (b) 6.

5. Fillers, Extraneous Matter, and Abrasives

This method is used for estimating such substances in greases and semi-solid lubricants, for the liquid lubricants, likewise, more exact information may be acquired than can be obtained by the centrifuge method (II) (d) 2.

Light-coloured lubricants may be dissolved in a naphtha-alcohol mixture 9/1, using an air condenser to prevent loss of the solvent. Dark-coloured lubricants dissolve more easily in a benzol-alcohol mixture (9/1). If the condenser is dispensed with and a beaker is used, the alcohol should not be added until just prior to filtering, or soap may be reprecipitated in the solution due to evaporation of the alcohol. A 10 to 20 g sample and about 250 ml of the solvent are sufficient.

Graphite residues should be filtered through a tared Gooch crucible (wt 1), otherwise use a No. 54 Whatman paper (tared if desired) and a hot-water funnel. Wash with hot benzol-alcohol until free from oil and soap.

Further procedure is governed by the character of the residue. Vegetable or animal fibres are dried, after which they are identified and separated microscopically unless present in large amount, in which event treatment with 4% NaOH will effect a separation.

Inorganic residues are washed with alcohol, the filtrate discarded, and any free lime dissolved by pouring dilute HCl (10% by wt) through the residue, followed by washing with hot water. Gypsum, if present, is quite soluble in dilute HCl and would give high results for the free lime. If lead is present, dilute HNO₃ should be used. These solutions are received in clean beakers, and the amount of the free base, i.e. Ca or Pb, determined.

The crucible containing the graphite is dried to remove

all traces of moisture, weighed (wt 2), ignited until free from carbon, and weighed again (wt 3), the loss in weight (wt 2—wt 3) representing *ash-free graphite*, while wt 3—wt 1 represents ash from graphite plus insoluble residue, and wt 2—wt 1 graphite plus total ash.

In the absence of interfering fillers, e.g. gypsum, an approximation of the ash in the graphite may be obtained

$$\frac{\text{wt } 3 - \text{wt } 1}{\text{wt } 2 - \text{wt } 1} \times 100 = \text{per cent ash in graphite}$$

The abrasive quality of this residue may be judged from a microscopic study of the particle size, sharpness, and hardness. Iron oxide, mica, quartz, and traces of calcium and magnesium oxides are the chief constituents. Ordinary mica may be identified by its K content, talc, its Mg content, &c.

Other inorganic residues after the acid and water leach may be dried, weighed, and examined microscopically for abrasive particles also. The paper and residue may be ignited and the ash weighed and reported as *siliceous residue insoluble in 10% HCl*.

Bureau of Standards Circular No. 372, Recommended Specification for Quiklime and Hydrated Lime for Use in Soap Making [12, 1929], allows a maximum of 1.0% of material insoluble in HCl (1.9). In a grease containing 20% Ca stearate the maximum insoluble from this source would be about 0.02%. A greater amount should be considered excessive in a lubricant for anti-friction bearings.

6. Soap

The detection of soap by the use of a saturated solution of metaphosphoric acid (HPO₃) in absolute alcohol has a very limited application in the examination of the lubricants under consideration. Conclusive evidence of the presence of soap is established by the detection of its two decomposition products, viz. the combined fatty acids and the metallic base. The methods of identifying the bases have been illustrated under "Ash". The combined fatty acids are determined in the following manner.

A. Light Greases. From 10 to 30 g of the lubricant, depending on the consistency, are weighed into a 250-ml separatory funnel, 75 ml petroleum ether (b.p. 30–60°C) and 50 ml 10% HCl are added, and the mixture shaken until decomposition is complete and a sharp separation takes place. The acid layer is drawn off into another separator. The ether solution containing all the oily matter is washed three times with small portions of water, adding the washings to the first solution, which contains the glycerine and the chlorides of the basic constituents of the soap. The acid solution is now washed twice with small portions of ether, the combined washings being shaken once with 15 ml of water to remove traces of acid, after which the ether extracts are combined and titrated with standard 0.5 N alcoholic KOH and phenolphthalein. From the value found here, the free fatty acid, previously determined, is subtracted to obtain the amount of *fatty acid combined as soap*.

Calculation of Acid Value of Combined Fatty Acids. Since it is difficult to maintain alcoholic KOH at a definite strength, the following equations are useful for calculating the acid value.

Acid value of TFA

$$= \frac{\text{ml KOH} \times (56.1 \times \text{normality of solution})}{\text{wt sample}}$$

Acid value of CFA

— (acid value of TFA) — (acid value of FFA)

FFA = free fatty acids TFA = total fatty acids

CFA = combined fatty acids

B. Dark Greases. A 6 to 10 g sample weighed into a 150-ml beaker is decomposed with 4 to 8 g K₂S₂O₈ at 100°C with frequent stirring. A constant-temperature electric oven is ideal for this purpose. From $\frac{1}{2}$ to 1½ hours are required according to the nature of the mineral oil.

Cool, add 125 ml petroleum ether (b.p. 30–60°C), stir, filter through a No. 40 Whatman paper or a qualitative paper of similar grade, using gentle suction. Collect the filtrate in a 500-ml Erlenmeyer flask. Wash out all soluble fatty acids from the beaker and residue and evaporate to low volume on the water-bath. Add 50 ml neutralized 95% alcohol, phenolphthalein, and titrate with 0.2 N alcoholic or aqueous KOH.

It is somewhat more accurate, although more complicated, to mix the sample with 10 g dry ignited sand in addition to the reagent, decompose as above, cool, and transfer to an extraction thimble, which is thoroughly extracted in a Soxhlet apparatus with petroleum ether.

The extract is evaporated and the fatty acids titrated. The acid value is computed as for light greases.

Calculation of the Soap.

In order to calculate the soap content the necessary data are

- (1) The percentage of the base or bases combined as soap (III (b) 4 a)
- (2) The acid value of the combined fatty acids (CFA) found above
- (3) The molecular weight of the combined fatty acids (III (b) 7)
- (4) The H-equivalent of the soap or soaps

Then the per cent soap equals

$$\frac{\text{H-equivalent of the soap}}{561} \times \text{acid value of CFA}$$

H-equivalent of the soap

$$= (\text{mean mol wt of CFA}) - 1.0 + (\text{H-equivalent of the metal base})$$

Example

- (1) Analysis of ash shows bases to be Ca and Na in the ratio of 95% Ca 5% Na
- (2) Acid value of CFA = 24.50
- (3) Mol wt of CFA = 295
- (4) H-equiv of soap = $(295 - 1.0) + 20 = 314$ (Ca soap).
H-equiv of soap = $(295 - 1.0) + 23 = 317$ (Na soap)

Correlating CFA with bases 24.50 × 100 95.

Acid value of CFA combined with Ca

$$= \frac{95 \times 24.5}{100} = 23.28.$$

Acid value of CFA combined with Na

$$= 24.50 - 23.28 = 1.22.$$

Then per cent Ca soap = $\frac{314}{561} \times 23.28 = 13.03$

And per cent Na soap = $\frac{317}{561} \times 1.22 = \frac{0.69}{}$

And per cent total soap = 13.72

For technical control analysis the molecular weight determination is customarily omitted and the fatty acids regarded as being composed solely of oleic, stearic, or

palmitic acid Or the molecular weight may be fixed in round figures at 300

That this may introduce considerable error will be apparent when we consider that lubricants may contain saturated acids which vary in molecular weight from 200 (lauric) up to 368 (carnaubic), and unsaturated acids such as erucic with a molecular weight of 338

7. Total Fatty Oil

In lubricants the total oily matter may include

Saponifiable fat	Free fatty acids and Neutral fat	Practically the only constituents of types 2 and 3 (excepting liquid waxes), varying amounts in types 4 and 6, sometimes in types 7 and 8
		Combined fatty acids
Unsaponifiable	Hydrocarbon oil	Almost 100% of type 1, sometimes traces in types 2 and 3
	Phytosterol	In vegetable oils and fats
	Cholesterol	In animal oils and fats
	Higher alcohols Rosin oil	In sperm oil in large amount

(A) In Lubricants of Types 7 and 8 When soap is a component of the lubricant it is customary to decompose the material with acid as in the preceding test. All soluble fatty oils, unsaponifiable and petroleum oils are then separated together from the bases by extraction with petroleum ether

The following diagram is adapted from the ASTM scheme of grease analysis (D 128-27) (6), the method of washing the various extracts being omitted in order to clarify the *modus operandi*. The numerals refer to the number of the test, listed in 'Methods of Analysis'

The letters refer to the operations, which are further described

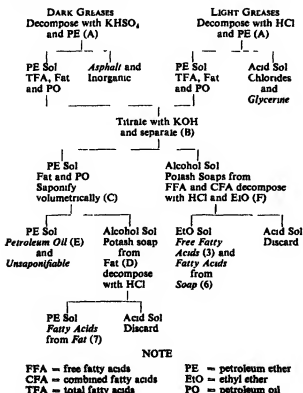

(B) In Lubricants of Other Types. The oil or the ether extract from (A) contains the total fatty acids, neutral fat, and unsaponifiable oil

Fatty Acids. Titration with standard alcoholic KOH gives the total fatty acids (see Method 6) which are now removed as the potassium soaps soluble in alcohol, most of the fats and oils, excepting castor, being practically insoluble in alcohol. All oils and fats, except castor, are soluble in petroleum ether

(C) Neutral Fat. The neutral fat may be separated by saponification with a measured amount of standard alcoholic KOH. Under Method 9 the details of the determination of the saponification value are given. This method is applicable to straight vegetable or animal fat and compounded oils

If the saponification value of the fatty oil is known, the per cent fatty oil = $\frac{100 \text{ (saponification value of sample)}}{\text{saponification value of fatty oil}}$

In technical analysis an average saponification value, e.g. 195 or 200, is used whenever further characterization of the fat is not desired

(D) The alcoholic soap extract after a quantitative separation from the petroleum oil and unsaponifiable (see E below) is decomposed with HCl, the petroleum ether solution of the fatty acids washed free from mineral acid, evaporated on the steam-bath until all ether has been volatilized, the last traces of water removed by addition and evaporation of 5 ml of absolute alcohol, and finally weighed as the fatty acids from the neutral fat. The nature of the oil may in general be determined by means of the molecular weight, iodine value, melting-point, etc. With less accuracy an arbitrary factor, such as 1.045, which is the factor for converting stearic or oleic acid to the respective tri-glyceride, may be used

Example

Tri-olein, $(C_{17}H_{33}COO)_3C_3H_5$ (mol wt 884.832)
Oleic acid, $C_{17}H_{33}COOH$ (mol wt 282.272) $\times 3 = 1.045$

(E) The method of Spitz and Honig has found considerable application for the separation of the fatty oil from the mineral oil. In the analysis of oils containing soap this method may be applied to the ether-alcohol solution after titration of the total fatty acids as in (B)

For oils of the E P type, containing added sulphur, the method with slight variations follows

Saponify 10 to 15 g of the sample by boiling with 25 ml 2 N alcoholic potassium hydroxide and 25 ml neutral alcohol under a reflux condenser for 1 hour. Add 50 ml water and again boil. Cool and transfer to a separatory funnel, washing the last portions into the funnel with 50% alcohol and 50 ml of petroleum ether (b.p. 30-60°C), settle, and run off alcoholic solution

Shake the soap solution with 50-ml portions of petroleum ether until the last extract is free from oil. Unite the petroleum ether extracts and shake three times with 15-ml portions of 50% alcohol, to which has been added a trace of alkali. Add this alcohol solution after shaking once with petroleum ether to the soap solution

Mineral Oil. The mineral oil may be determined by evaporating the petroleum ether solution on a water-bath in a weighed dish. (If the mineral oil residue contains a few drops of water, add 5 to 8 ml of absolute alcohol and heat until the alcohol has evaporated; the evaporation of the alcohol is complete when the bubbles of foam on the

surface disappear) Dry the mineral oil at 100°C to constant weight.

(F) Evaporate the alcohol-water soap solution, obtained above, until free from alcohol. Dissolve in a little water and treat with an excess of dilute sulphuric acid in the presence of diethyl ether, in a separatory funnel. Run off the acid layer and wash the fatty acid solution with concentrated sodium sulphate solution and with distilled water until the wash does not turn methyl orange red. Dry the ether by adding a few pieces of calcium chloride, filter and evaporate the ether, dry the residue of fatty acids for 5 min at 105°C.

The presence of oxy-acids may indicate blown oils, castor or fish oils, they are insoluble in ether and should be separated by filtration.

The fatty acids may be examined further in order to identify the oil. A knowledge of the average molecular weight of these acids is essential for computation of the soap (Method 6) if the acids existed in such combination in the original material.

Molecular Weight About 2 g of the fat are accurately weighed into a 200-ml Erlenmeyer flask and the saponification value determined according to Method 9. The molecular weight is then found from this equation

$$\text{Mol wt} = \frac{56,100}{\text{sap value}}$$

1 gram-molecule of KOH = 56.1 g = 56,100 mg

8. Petroleum Oil and Unsaponifiable Matter

The method for a quantitative separation has been discussed in the preceding method 7 (E).

The presence of rosin oil or various waxes may be verified by suitable tests. Rosin oils have a high specific gravity (approx 0.98), in the polarimeter they are dextro-rotatory (-30° to -40°), solution in acetic anhydride treated with 1 drop of H₂SO₄ (1.53) gives a characteristic fugitive violet colour (Leibermann-Storch reaction), Valenta's test indicates quantitatively the amount of rosin oil in mineral oil by the difference in their solubility in glacial acetic acid.

Unsaponifiable matter in animal and vegetable oils exists normally in very small amounts. Samples of pure oils examined by the writer showed the following amounts

Cotton-seed oil	0.29%	Orange-coloured solid
Castor oil	0.35%	Bright yellow needles
Lunseed oil	1.03%	Orange-yellow waxy solid
Lard oil	0.16%	Yellow solid

These residues retain considerable colouring matter and resins. They are of great importance in distinguishing between oils of animal and vegetable origin due to the presence of characteristic alcohols, cholesterol



in the former fat, and phytosterol in the latter.

The petroleum hydrocarbon oils are usually tested for specific gravity, viscosity index, and sometimes for the pour- and flash-points. Considerable insight into the molecular structure of these oils may be obtained from the above physical properties in connexion with the molecular weight.

9. Saponification Value

This test is useful in ascertaining the purity of animal and vegetable oils rather than as a means of identification,

it is used to determine the amount of fatty material in compounded oils, in which interfering compounds are absent. The caustic interacts with certain sulphur compounds in some E.P. lubricants, in oils of this kind the Spitz and Homig method should be followed.

Procedure. From 2 to 20 g of the oil are weighed accurately into a 300-ml Erlenmeyer flask, 25 ml N, alcoholic KOH solution (colourless), and 25 ml neutral alcohol or benzol are added, the flask is connected to an air condenser and boiled from 1 to 3 hours until the reaction is complete. Run blanks concurrently with the samples. Wash the condenser with neutral alcohol and titrate hot with 0.5 N HCl, using phenolphthalein as an indicator.

Sap value

$$= \frac{(\text{ml blank} - \text{ml titration}) \times 56.1 \times \text{normality of HCl}}{\text{weight of oil in grams}}$$

Saponification values for a large number of oils will average about 195, sperm oil, 120-37, whale, 160-202, castor, 175-83, rape, 168-79, and blown oils vary greatly from this average.

10. Constants of Fatty Acids

The melting and solidification points, iodine value, acid value, and molecular weight of the isolated fatty acids in conjunction with the odour and taste usually suffice to establish their identity.

The iodine number provides perhaps the most important guide in the analysis of oils and fats, since their classification into drying, semi-drying, and non-drying oils is based upon their capacity for assimilating the halogen. It supplies a ready means of distinguishing between the saturated and unsaturated fatty acids or between the corresponding glycerides. The Wigg solution reacts rapidly and gives results somewhat higher than the Hübl solution. The iodine trichloride used in the Wigg solution is difficult to keep and weigh, but the solution is quite stable. On the other hand, the Hübl solution are easy to prepare, but are rather unstable and much slower to react with the oil. The solvent, e.g. chloroform, should show no reducing action on K₂Cr₂O₇ in the presence of H₂SO₄.

The iodine value may be used to calculate the per cent of one fatty oil mixed with another.

In a mixture of two fatty oils in mineral oil, saponify and separate the fatty acids, then determine the iodine number of the mixed acids

$$\begin{aligned} \text{Let } X &= \text{per cent of one fat,} \\ Y &= \text{per cent of the other fat,} \\ m &= \text{iodine value of fat } X, \\ n &= \text{ " " " } Y, \\ I &= \text{ " " " the mixture} \end{aligned}$$

$$\text{Then the per cent of one acid, } X, = \frac{100(I-n)}{m-n}$$

The acetyl value is a measure of the hydroxyl content of the oil. Upon acetylation every alcoholic OH group takes on an acetyl (CH₃CO) group. During saponification the acetic acid is split off. The number of mg of KOH required to neutralize the acetic acid from 1 g of the oil gives the acetyl value. In the identification of castor oil or the separated ricinoleic acid this constant is of importance. Each molecule of ricinoleic acid upon boiling with acetic anhydride takes on 1 acetyl radical and on saponification

splits off 1 molecule of acetic acid equivalent to 1 molecule of KOH. Thus

Ricinoleic acid

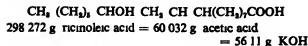

Therefore

$$1 \text{ g ricinoleic acid} = 188 \text{ mg KOH} = \text{acetyl value}$$

11. Chlorine

(A) *Organic Chemistry*, by W. A. Noyes, describes the method for this determination adapted to the Parr peroxide bomb. The sample, 0.3 to 0.4 g, is mixed with 1 g KNO_3 , 14 g Na_2O_2 , and 0.5 g powdered granulated sugar. After ignition the melt is boiled with 150 ml water, acidified with HNO_3 , and an accurately measured excess of 0.1 N AgNO_3 added. Then add 10 ml 4% hydrazine sulphate and boil to coagulate the precipitate. Filter and wash free from AgNO_3 . To the filtrate add 5 ml of 6 N HNO_3 and 5 ml of a saturated solution of ferric alum and measure the excess AgNO_3 by titration with 0.05 N NH_4SCN or KSCN . The end-point is a pink colour. The AgCl may be determined gravimetrically by filtering through a weighed Gooch crucible followed by drying at 110°C .

(B) The Parr oxygen bomb, such as described in the estimation of sulphur, is equally adapted for chlorine determinations, although any bomb lining of nickel-chromium alloy is more susceptible to the action of HCl than of H_2SO_4 .

The chloride may be determined volumetrically or gravimetrically according to the procedure outlined above. Chlorinated lubricants labelled E P oil for crank-case use are now being widely sold. Possibility of very destructive corrosion of aluminium and steel parts, if HCl should be

formed, is a potent argument against the promiscuous use of such compounds until conclusive tests have demonstrated their suitability for general usage.

12. Water

The amount of water is determined by distilling a mixture of the lubricant with a specified solvent, the water being condensed and collected in a trap graduated from 0 to 10 ml in 0.1 ml divisions (A S T M D 95-30).

For greases 25 g samples are convenient, while 100 ml of oil are generally taken. In the latter instance the reading gives the per cent. of water by volume directly, while with greases the reading multiplied by 4 gives the per cent. water by weight.

The liquid lubricants, unless the soap content is high, contain only traces of water, semi-solid and solid greases may be anhydrous or they may contain 8-10% water, e.g. the so-called waterproof greases.

Lime-soap cup greases have a water content ranging from 1 to 3%. Special lubricants used in metal-forming may contain 50-60% H_2O . For testing such material a 10 g sample should be taken.

(C) Special Tests.

Mineral oils, thickened with wax, petrolatum, or asphalt (Type 1), are recognized by their low ash content.

Asphalts are recognized by their colour and insolubility in petroleum naphtha or alcohol-ether.

Petrolatum has a low specific gravity (0.825-0.885) and a lower melting-point (110 - 30°F) than even the lime-soap greases (185 - 205°F). It may be separated by treating the lubricant with a special solvent and chilling below 0°C .

Paraffin wax may be precipitated by dissolving the lubricant in methyl-ethyl ketone, cooling to -20°C , and filtering and washing at a low temperature.

REFERENCES

- 1 ARVESON, M. H. *Ind Eng Chem (Jan 1932)*
- 2 A S T M Serial Designation D 88-33
- 3 --- D 91-33
- 4 --- D 95-10
- 5 --- D 96-30
- 6 --- D 128-27
- 7 --- D 129-34
- 8 --- D 189-30
- 9 --- D 217-33T
- 10 --- D 341-32T
- 11 BULLLEY, R., and BINTNER, F. G. *Bur Stand Res Paper No 188 (1930)*
- 12 Bureau of Standards, Circ No 372 (1929)
- 13 *Federal Standard Stock Cat* sect iv, pt 5 (3 Oct 1933) (revision of B S Tech Paper No 323a)
- 14 FOSLER, C. A. *Nat Petr News* (9, 16 March 1932)
- 15 GARNER, F. H., and KELLY, C. I. *Physics*, 4 (March 1933)
- 16 HERSCHEL, W. H. *Bur Stand Tech Paper No 210 (1932)*
- 17 HOLDI-MUELLER. *Exam of Hydrocarbon Oils, etc* 2nd edit (1922)
- 18 LANG, F. W., and DEVINE, J. W. *U S Bur of Mines Rept Invest* 2828
- 19 LARSON, C. M. *J S A E (Jan 1931)*
- 20 LEDERER, E. R., and ZUBLIN, E. W. *Nat Petr News* (13 Sept 1933)
- 21 *Nat Std Petr Oil Tables*, *Bur Stand Circ No 154 (1924)*

SECTION 22

HISTORY AND DEVELOPMENT OF REFINING

**History and Development of some Important
Phases of Petroleum Refining in the United
States**

W MILLER and H G OSBORN

HISTORY AND DEVELOPMENT OF SOME IMPORTANT PHASES OF PETROLEUM REFINING IN THE UNITED STATES

By WALTER MILLER and HAROLD G. OSBORN

Continental Oil Company

A TECHNOLOGICAL art progresses in direct ratio to the economic necessity for such development. Petroleum refining is no exception.

The important economic force in the early development of the refining art was the increasing scarcity of whales, which had furnished oil for the lamps of the civilized world for hundreds of years. The comparatively poor kerosene produced from coal distillation, by which the decreasing whale-oil supply was augmented about the middle of the nineteenth century, made an unsatisfactory substitute, although many plants for making 'coal oil' were operated, mostly in the eastern states, following in general improved English practices developed by Dr. James Young. These installations prospered until the Drake discovery in 1859 rapidly made the more economical petroleum kerosene available. The comparatively great demand brought in its train the problem of utilizing the by-products of the crude oil processed. The general need for more lubricants, coupled with the refiners' increasing ability to make suitable products, resulted in the encroachment of petroleum lubricating oils into fields formerly exclusively supplied by animal, vegetable, and fish oils, and provided a partial answer to the by-product problem. The discovery by a stillman in 1862, induced by high costs of coal and wood fuels, that the heavy liquid residues could be successfully atomized with steam into a suitable furnace fuel, also contributed to the answer. But gasoline continued to be a troublesome by-product for long years. Even the demand created by the development and successful distribution by the Standard Oil Company of a naphtha-burning stove fell very short of absorbing the supply.

The use of artificial gas and electricity to the displacement of the demand for kerosene brought a gloomy note into the petroleum industry. Bridged for a while by the development of foreign demand and increasing exports, the situation was none too good at the time the internal combustion engine, with its gargantuan appetite for gasoline and lubricants, proved to be the greatest of all the economic forces which have brought the industry to the prominent place it occupies in the life of man to-day. And it may well be said that while the industry owes much to the galvanizing effect on its progress of the growth of the automobile, the fact that it alone could produce the necessary suitable fuels and lubricants contributed a large part to make this possible.

Petroleum Distillation

Always the major function of refining, distillation in the beginning of the art was almost the sole activity of the refiner.

Visualize, as a starting-point, the earliest stills, borrowed or taken over from the 'coal oil' refineries, some oval, some round in shape, generally vertical, of cast iron, bottoms and walls sometimes 6 inches in thickness, capacities of 6 to 60 barrels, with a thermometer and a 'gravity stick' the only control instruments available.

What were the steps which spanned the interval to the present time?

Worth noting was the development, in the early 1860's, at the Humbolt refinery between Titusville and Oil City, of larger stills of the horizontal type made of comparatively thin wrought-iron plates, although the use of the upright type persisted in some refineries for 20 or 30 years. Also the oft-told story of the discovery of cracking—and its important effect in increasing yields of kerosene—by the operator who, suddenly taken ill, returned to his 16-barrel still after 4 hours' absence to find an abnormally high kerosene yield with production still going on, a circumstance so surprising to the chemist-proprietor that investigation and experimentation on his part led to the general adoption of the practice of allowing heavier vapours to condense and return to the still for cracking, bringing about an increase of at least 20% of the principal product of what has so aptly been called the 'kerosene age' of the industry.

Continuous distillation received early attention, at least two covering patents being issued between 1860 and 1870. It is surprising to note that in spite of some successful utilization abroad very little was accomplished in this country for a long time. In 1877 Samuel Van Syckel pointed the way by continuously operating a battery of steam stills for a time, but it was in 1885 and later before any general use of the principle was made, the Atlantic Refining Company being one of the first to perfect the operation in a large way.

For the next 20 years, until about 1905, little important progress was made in the art of distillation, but about that time a decided forward movement was initiated, which gradually assumed great impetus. Surprising in retrospect is the lack of appreciation previous to 1905 of the possibilities of selective condensation as an aid in the fractionation obtained from distillation. Although Leet, writing in 1884, had called attention to the suitability of the bubble tower as then known, "following the plan of whisky rectification", it was not until more than 30 years later that any serious application of it was made to petroleum refining, and no adequate explanation for the delay in the adoption of this important fractionation device can be given even to-day. True, the benefits of the enlarged still dome and exposed still tops, where dephlegmation for kerosene cracking was sought, were early recognized. The classic Dewar-Redwood cracking patent of 1890 shows an enlarged still head and specifies "during the distillation such of the vapour as may be condensed in the still head . . . flows back into the body of liquid . . . and if necessary means of cooling may be applied to the still head".

A noteworthy and revolutionary step was the tower developed in the Atlantic Refining Company's plant in Philadelphia in 1905 by Messrs. Van Dyke and Irish, a combination of a stone-filled vertical tower with a two-section air-cooled tubular partial condenser, the tubes somewhat slant to provide air turbulence on the cooling



FIG. 1. Trumble heating coil from an early pipe still in a California refinery.



FIG. 2. A single-tower, multiple-stream pipe still of 7,500 barrels daily capacity built in 1926. In foreground, insulated tanks for hot residuum and in middle distance, with open manhole, a vacuum pot used when running crude to lubricating oil or bright stock residuum.

side and impinging surface for downward condensate flow within the tubes, with means at three points for withdrawing condensate from the system or returning it to the still for cracking for wax improvement and increased yields of kerosene and naphtha.

The closer control of the fractionation and quality of products obtained thereby was quickly acclaimed, and the equipment soon came into considerable use, principally among the Standard Oil Company subsidiaries. This development did much to stimulate many experimenters who carried on investigation for further utilization of the principles and advantages taught by it. By the time the original Burton cracking-process patent was applied for in 1912 the art had progressed to the point of using a rather long vapour line, which 'inclines upwardly therefrom to induce the return flow into it (the still) of unvaporized portions of the liquid'. Burton's next step was to add another vapour line to increase the exposed cooling surface, augmented a little later by a small air-cooled radiator-type pipe condenser called from its appearance the 'banjo tower'. The need for progress of this sort was apparent when it is recalled that at this period so excessive was the redistillation required to separate properly the finished products that it was not unusual for refineries, carrying their operations to coking of crude and making of lubricating oils, to have a total distillation capacity of from three to four times the quantity of net crude oil actually processed. Later W. M. Burton and associates of the Standard of Indiana and John L. Gray and associates of the Tide Water Oil Company applied the principle in the direction of small multiple air-cooled towers connected in series, for obtaining closer fractionation and control, used principally in redistillation for lubricating oils.

From this point onward the development of the fractionating tower and the art of selective condensation were closely allied with pipe-still development and the progress of distillation generally.

While the Van Dyke-Irish tower and coking still were being installed in the east, the pipe still was being developed on the western seaboard. Undoubtedly the difficulty of dehydrating the heavy California crude oil in shell stills was the initial incentive for development of pipe heaters. This growth is described in detail by J. M. Wadsworth in Bureau of Mines Technical Bulletin No. 162, published in 1919, in which the history and early design of plants after the ideas of A. F. L. Bell, I. W. Fuqua, and M. J. Trumbull are described. Of interest is the fact that the idea of the original Dubbs cracking patent, applied for in November 1909, grew out of the operation of a small pipe-still crude dehydrating plant built at Santa Barbara to boil the water from the rather badly emulsified heavy crude produced in that area.

The step forward in fractionation from the comparatively small air-cooled pipe towers used as partial condensers and dephlegmators, and the larger vertical towers filled with granite or broken vitreous ware (hence the name 'crock' tower), to the use of the early baffle-plate type of dephlegmator and fractionator, which provided a closer approach to the fractionation methods used in 'the art of whisky rectification', passed through its early development largely in California. Along with this trend went an increasing development and use of heat exchangers.

It is possible that the Californian refiners might not have so far outstripped the refiners east of the Rockies in improvements made in these branches of the refining art (pipe distillation, fractionation, and heat exchange) had it not

been that cracking, because of the greater profits possible from the conversion of heavy products into gasoline to supply the ever-mounting market demand, occupied the effort and attention of the operators in the east. Cracking played little part during this period in the activities of the western group. The economies possible there, in fractionation, heat exchange, and more efficient primary heating were large, both because of the comparatively small proportion of overhead products from the heavy crudes available in California and the higher fuel costs involved, California not having unlimited supplies of cheap coal. The use of heat exchangers, effecting the double economy of reducing the quantity of water required for cooling and condensing, and making for less use of expensive fuel, offered much greater returns for them. More fractionation offered similar economies to the degree that the returning of distillates was reduced. In other words, improved and increased cracking operations offered greater profit possibilities to the eastern refiners, while the lack of a cracking process which would successfully handle the Californian asphalt-naphthene base cracking stock, and the higher cost of fuel, forced development there in the low-pressure distillation art.

By 1920, however, appreciation of the value of pipe stills, baffle-plate towers, and exchangers became fairly general throughout the industry. Progress from then on was furthered by experience with the various types of furnace coils and fractionating towers used in the early units of the Dubbs, Cross, and Greenstreet cracking processes, and the still earlier application of water-tube boiler settings to cracking drums by Burton and Clark, S. H. Edwards, and others.

It was but a short time later in the development of the art of fractionation that the bubble tower made its belated entrance into the refining field. Although used successfully for several years in casing-head gasoline separation, there was definite resistance on the part of refiners, by some on the ground that the finer fractionation claimed for the new tower was not needed, by others on the theory that while it might work on the simple mixtures encountered in the alcohol and coal-tar industries, petroleum distillates were entirely too complex to be satisfactorily separated by such means.

The early application to the Burton cracking still (Lewis and Cook U. S. P. 1,392,583 issued in 1920, and quite recently adjudged invalid by the courts), the use of second-hand alcohol bubble towers by J. L. Gray and F. E. Holsten in connexion with a commercial-sized installation of a low-pressure Ramage process cracking unit at Barnsdall, Oklahoma, and the contemporaneous successful application to Cross process cracking soon convinced doubting refiners that here was something new with which they had to reckon. The bubble tower may be said to have reached at least general toleration, if not acceptance, by 1924, at which time its broad application to all forms of distillation may be said to have commenced.

The last 15 years of petroleum distillation history have been marked by a rate of progress surpassing any other period in history. As refiners, chemists, and engineers developed greater knowledge of fundamental principles they were aided in application to the refiner's art by those skilled in metallurgy, combustion, welding, instrument-making, &c. While at the beginning of this period much of the work in connexion with refining engineering and installations was still being carried out by and within the industry, progressive refiners were giving up the idea that it showed lack of ingenuity and invention to adapt anything

from other arts or to call on others for engineering and technical help. The effect of the dissolution of the Standard Oil Company some years previously, making as it did more or less independently operated units of the largest refining organizations in the country, was bringing out greater rivalry and competition in professional and technical development as well as in the business end. Many of the universities and colleges were turning out graduates equipped with a great deal of specialized training along petroleum lines in addition to their general engineering and chemistry qualifications, and the value and need of such assistance in refinery organizations became much more broadly recognized. Forums for the interchange of knowledge and experience were provided by the American Petroleum Institute and similar sectional associations, such as the Western Petroleum Refiners' Association and the National Petroleum Association. The national engineering and chemical associations provided similar opportunities as refining attracted in greater numbers trained engineers and chemists from the schools and the technological arts, bringing with them a progressive spirit and a knowledge of experience and accomplishments in other branches of technical endeavour having analogous operations and problems. The slowing up of the alcohol industry due to national prohibition made available experts and equipment designers and constructors, who brought their fundamental knowledge and experience to petroleum distillation as their new field, and contributed especially as to fractionation generally and the bubble tower particularly.

The bubble tower, during the years which have elapsed since its first practical application in the industry, has gone through a refining, amplifying, and metamorphosing process which makes it difficult to recognize the relationship between the present and the early installations. Its early use on pressure stills (the Burton and the Cross in the early 1920's, previously referred to) was comparatively simple because it was obviously for a single end product. With its application to crude distillation at normal pressures and lubricating-oil distillation under vacuum there was quick recognition of the need for more flexibility. The early step to multiple towers, sufficient for the number of fractions desired, involving expensive and complicated construction, was soon superseded by the multiple stream towers, less costly to install and simpler to operate. The first commercial-sized multiple-stream installation, consisting of three 5,000-bbl units, was placed in operation by the Atlantic Refining Company early in 1926, followed soon after by a 7,500-bbl unit, built by the Foster-Wheeler Corporation in conjunction with a pipe still of their design at the Continental Oil Company's refinery in Ponca City, Oklahoma, which permitted the continuous fractionation of a crude stream of 7,500 bbl a day into gasoline as an overhead product, with a number of side streams or 'cuts' from which were obtained kerosene, gas oil, and lubricating distillates, and either cylinder-stock raw material or asphaltic flux as a residue. Further refinements include that of the introduction of selected refluxing oils at different levels in towers to control the fractionation through the entire column, and the return to the main column of vapours stripped from the side stream. The cracking art also gained from this development as the side-stream principle was used for withdrawing from the system selected fractions of the tower stream as furnace fuels or other special products, and also refractory stocks to be cracked under pressure and temperature conditions more applicable to the fractions withdrawn.

Greater interest in vacuum distillation was stimulated in the early 1920's as Schulze introduced his low absolute pressure shell still unit, later converted to continuous multiple still operation and otherwise improved. The important effects of the later combination of 'high vacuum' (i.e. low absolute pressure) with the pipe still and bubble tower will be discussed under 'Lubricating Oil Manufacture'.

The art of heat exchange during the same period kept pace with bubble-tower and distillation practice. Starting with the simple method of recovering heat from crude residue of the continuous still operation by pumping the hot residue through a coil in a drum, through which the crude was preheated on its way to the stills, various refinements came rapidly as metals and equipment were developed to withstand more severe conditions. While the improvements made were generally the result of combined efforts of refiners and equipment engineers and specialists, much of the progress made came as a result of the rapid developments of this kind in the cracking art. It was in this branch that one outstanding individual contribution was made, the high-pressure vapour heat exchanger and fractionator developed by C. H. Leach. Pointing the way to recovering successfully available heat in high-temperature vapours under high-pressure conditions while taking advantage of useful fractionation possibilities, the various improvements in exchanger equipment and utilization hastened the progress in heat-exchange practice which released more available heat from the exothermic cracking operation than could be used in the cracking unit.

This additional available heat, in connexion with the long non-stop runs of cracking units which became possible as the art developed in the control of coke formation and other factors, was a most important item leading to the development of the combination skimming and cracking unit which was introduced 7 or 8 years ago. An early step was in the building of units which in addition to distilling and fractionating the crude also lightly cracked in the same operation the residual oils for the production of 8 or 10% of gasoline (which operation was carried out without royalty payments) and a by-product gas oil charging stock for the orthodox cracking stills.

The designing and installing of true combination units involving the use of otherwise waste heat from the cracking operation were simultaneously initiated, but independently of each other, about the middle of 1928 by the Continental Oil Company at its Wichita Falls, Texas, refinery (a 5,000-bbl unit), Winkler & Koch Engineering Company at the plant of the Root Refining Company in El Dorado, Arkansas, with a capacity of 4,000 bbl, and the M. W. Kellogg Company in the installation of eight units at the large plant of the Pan-American Petroleum & Transport Company (then a Standard Oil Company of Indiana affiliate, but now owned by Standard Oil Company of New Jersey interests) on Aruba Island off the coast of Venezuela, South America.

The building of the first of the very large modern units, a 20,000-bbl combination still at the Whiting, Indiana, refinery of the Standard Oil Company of Indiana in 1932 by the M. W. Kellogg Company, was watched with a great deal of interest by the industry. This unit was the first to have included as an integral part of design and operation, facilities for 'reforming' the low-octane straight gasoline. Its success paved the way for many other large units, some now in operation and others in process of construction. The completion in 1934 of a 32,000-bbl unit at the Texas City refinery of the Pan-American Petroleum & Transport



FIG. 3 Replica of first commercial refinery built in California in 1876 by predecessor of Standard Oil Company of California. Less than 100 barrels capacity



FIG. 4 Combination unit of 32,000 barrels daily capacity at Texas City, Texas, refinery of Pan-American Petroleum and Transport Company

Company, an associate company of the Standard Oil Company of Indiana, and the second still now being constructed in the same place of approximately 35,000-bbl capacity, both plants including the Cray Vapour Phase Process equipment for refining the cracked gasoline produced, indicate clearly the present-day trend of petroleum distillation activities under conditions not involving lubricating-oil production, but having as the main objective the maximum production of gasoline.

It can truly be said of the gasoline manufacturer to-day as could be said of the refiner in the early beginning of the art, that distillation is almost his sole processing activity.

But there the analogy ends!

Lubricating Oil Manufacture

While during the infancy of the refining art by far the majority of thought and effort was necessarily devoted to the development of improved methods of distillation and related functions, lubricating-oil manufacturing was not long overlooked, and the story of its development contains many interesting chapters.

One of the earliest uses of a petroleum product as a lubricant is referred to in Redwood's *Treatise on Petroleum* in which he speaks of cart-grease being prepared from petroleum in Galicia from very early times. Commencing about 1806, petroleum was recovered in small quantities by salt-makers from salt-wells in Ohio and West Virginia, which, according to an article written by a Dr Hildreth in 1833, was used both as an illuminating and lubricating oil, displacing the sperm oil which had answered these purposes in the localities where this rock oil was found. Redwood quotes in part directly from Dr Hildreth's article: "In neighborhoods where it (rock oil) is abundant it is burned in lamps—it is also well adapted to prevent friction in machinery—it preserves the parts to which it is applied."

It was several years before the first petroleum refinery was operated in the United States that Professor B Silliman, jun., of Yale College, reporting in 1855 on the commercial possibilities of refining petroleum for illuminating oils, after commenting on the valuable wax content of petroleum, referred to lubricating values in a brief paragraph as follows: "As this oil does not gum or become acid or rancid by exposure, it possesses in that, as well as in its wonderful resistance to extreme cold, important qualities for a lubricator." Even 5 years prior to that, British patents issued to Dr James Young (based largely on shale oil experience and under which many American refiners took licenses) showed a broad knowledge of the refining processes required to produce lubricating oils. His patents treated redistillation for removal of light hydrocarbons of non-lubricating value, desalting by acid treatment, and neutralizing with caustic soda.

While some sporadic and impromptu use was made of petroleum residues for lubricating purposes in earlier years, it was not until about 1865 that certain refiners started experimentally with the making of lubricating oils as overhead products. Leet, in his book on *Petroleum Distillation*, published in 1884, credits Samuel Downer with being the first to accomplish this successfully. Downer's initial product was of too low a viscosity to be of much value, but led to the practice of continuing the distillation of the crude oil to higher temperatures and producing an overhead distillate which gave a finished oil of more suitable viscosity characteristics. In a patent issued in 1869 to Hiram B Everest, the latter suggested the use of partial vacuum distillation in connexion with steam distillation, a method

which had actually been practised by him for some 3 years in the Rochester, New York, refinery of the Vacuum Oil Company.

Downer and other early manufacturers of neutral and paraffin oils first used ice or mixtures of snow and salt in cold rooms to chill oils to be dewaxed, placing the resultant cold, pasty liquid in a pressing 'bag'. This was simply a large square piece of canvas, the corners folded over to make a square package. A vertical hydraulic press served to squeeze the liquid oil through the pores of the canvas. This method of dewaxing, with the subsequent substitution of shallow pans and ammonia coils for the ice or the snow-and-salt mixture, held until about 1880, when the horizontal frame and plate presses, still in general use, were adopted. It is interesting to note that while mechanical improvements have been made in these presses, and the press now in general use has a 48-in plate compared with the 27-in plate first used, there is no fundamental difference in the method. The more complete removal of wax afforded by this innovation made a definite improvement in lubricating oils because of the lowering of the cold test, which resulted immediately in a wider field of usefulness and application. Filtration of some of the lubricating oils through 'bone black' or 'bone char' to improve colour and odour, either replacing or following the usual acid and caustic-soda treatment, was early adopted for the lower viscosity oils intended for light, high-speed bearings. One of the early writers complained bitterly of the injustice of granting a patent for the use of animal bone char for filtering petroleum products in 1864, on the ground that the general usefulness of this material for such purposes had been known for centuries and practised openly in the industry for several years prior to the granting of the patent.

The introduction of the horizontal frame and plate press probably marked the real beginning of the commercial importance of the paraffin-wax industry. 'Cutting' or dissolving the slack wax from the original pressing in 'torch oil', a light distillate in the kerosene range, with subsequent chilling and repressing of the solution, resulted in the production of a yellow crude scale wax. Diluting this in turn with naphtha as a solvent, cooling and again pressing, then filtering through bone black (or later fuller's earth), yielded the white refined wax of low oil and moisture content and good odour and taste, so well known to-day, which in the early days of the industry was used almost exclusively in the manufacture of candles.

The use of the plate press had another important economic effect upon the manufacture of lubricants. The pressing method of extracting wax from lubricating oil was much less expensive than the former cumbersome, laborious methods, and the comparatively new refined wax which it produced as a by-product gave another source of income to the refiner, the two factors tending to decrease materially the cost of the lubricating oil itself. Exports of lubricating oil, which had started in a very modest way in 1869 and had risen to nearly 2,500,000 gal a decade later, doubled to over 5,000,000 gal in 1880 and increased over five times in volume during the next 10 years, as against comparatively minor increases in the exportation of illuminating oils and other petroleum products. This period of rapidly increasing export of lubricating oils was marked by additions to manufacturing capacity, brought about both by increased demand and periods of high prices. Occasional over-production resulted in competition which brought about diversification and specialization. Consumers who had remembered only the advantages over the early

petroleum products of the straight lard, tallow, and other fixed oils they and their forefathers had previously depended on were induced to accept blends with increasingly greater proportions of the new oils

Progress in standardization of tests, testing methods, and specifications was comparatively slow among the refiners themselves, yet they were far ahead of the consumers, who in many cases were the victims of misplaced confidence in the assertions of salesmen, but whose salvation was the truth of the proverb that 'All oils will lubricate'. The requirements were not severe, measured by standards of today. The high-temperature lubricating condition brought about by the internal combustion motor was still non-existent, and while in cases of difficulty recourse was frequently had to inclusion of fixed oils such as sperm, menhaden, tallow, lard, or other fish, vegetable, or animal lubricant as a cure-all, such experiences usually became the basis for study, 'cut and try' experimentation, and further improvement in petroleum oil quality, due to the increasingly high cost of these 'fixed oil' ingredients. Probably 80% of the distillate lubricants were finished by chemical treating only, 'Export 907', 'Solar Red Paraffin', '25 Paraffin', and similar designations becoming known and used throughout the industrial world. Filtering as a final refining step was used for the spindle oils and similar products designed for special purposes requiring a more highly refined grade. Products from Pennsylvania crude oil were almost invariably used as the source of oils to be filtered.

Comparatively slow progress was made during the period ending about 1910, at which time the influence of the internal combustion engine began to be felt. Redistillation, sulphuric acid, caustic soda, and bone black held sway for a long time. Mechanical improvements were made from time to time, but chemical progress played small part. Such improvement in quality of oils as was made was mostly in the direction of greater uniformity. Fuller's earth was used in place of bone black as early as 1898 by George H. Taber, sen., of the Gulf Refining Corporation, one of the progressives, but was looked upon askance by many and, in spite of its economic advantages, did not reach complete acceptance for lubricating-oil filtration until about 1906. It took another 4 or 5 years to dislodge bone black from its last stronghold, the filtration of wax, after refiners learned that while wax filtered through new or comparatively little-used fuller's earth had an objectionable taste and odour imparted to it, earth which had already been spent as an oil-filtering medium yielded a highly satisfactory product.

Another development contemporaneous with the adoption of fuller's earth as a filtering agent for the better grades of lubricating oil was the introduction to the industry of the second notable progressive step in wax manufacturing, some 25 years after the adoption of the frame and plate press. 'Sweating' was the apt name given to the method of refining waxes by first chilling the 'slack wax' derived from the wax presses, and then selectively fractionating by controlled melting of the mass either in 'sweating ovens' or 'tank sweaters'. The great advantage of this method over the 'torch oil' and repressing operation quickly brought about the displacement of the latter, and in the course of another few years a second sweating step, or rather 're-sweating' of the crude scale wax, supplanted the more cumbersome and expensive naphtha dilution and pressing steps in the making of highly refined wax. Except for minor improvements in equipment and automatic tem-

perature control of the melting cycle as progress in instrumentation made this possible, the sweating operation is substantially the same to-day, showing that the early development was well based.

Development of residual lubricants pursued a somewhat different course. The first cylinder oil produced from Pennsylvania crude oil, by the use of steam in distillation to prevent coking, was comparatively unsatisfactory both in use and appearance. The effect of the reduction of distillation temperature on preservation of lubricating qualities and appearance was quickly noted, and soon resulted in the use of very large quantities of steam and to some extent, as previously noted, partial vacuum. Even this improvement left much to be desired and the next step was filtration through bone char, producing a more highly refined oil with a good outer colour or 'bloom' and largely free from the asphaltic matter present in the unfiltered product. It was then discovered that the black asphaltic material had acted as an inhibitor to wax solidification or crystallization and that its removal from such oils engendered a much higher cold test, raising the solidifying point to 90° F and higher. This undesirable effect acted as a deterrent to more general use and brought the question of wax removal to the fore.

Just when it was discovered that a considerable proportion of the wax in crude oil would settle to the bottom of the storage tanks under certain low temperature conditions is not known, but it was probably about 1890. McDowell Gray, in his *History of Bright Stock Manufacture*, stated

however, the story is told that a manufacturer running through his stills crude that had been in storage during a very severe winter was surprised to find a wide variation in the cold test of the finished product.

Investigation showed a deposit in the lower part of the tank of a heavy, waxy product and much less wax in the oil in the upper part of the tank. The filtered cylinder stock made from the low wax content part of the settled crude finished with a cold test of 30 to 40° lower than that made from the unsettled crude, and remained clear and translucent at ordinary temperatures, hence the name Bright Stock. The immediate effect of the lower cold test served to widen further the field of use, and the material commanded a much better price than the previous product. Successful settling was possible only under long-continued cold within rather narrow temperature fluctuations. Woe betide the refiner if a period of extremely low temperature intervened and the crude became too viscous and sluggish, or a sufficiently long interval of warm weather reversed the convection currents, returning the wax to the upper portion of the tank. As in champagne production, there were 'vintage' years of good production and quality, and years of low production and high cold test. This lack of reliability stimulated investigation of a more positive method of dewaxing. E. B. Gray and associates of Tide Water Oil Company found in 1894 that cooling a solution of filtered cylinder oil and 70° gravity naphtha brought about a settling of the wax. It was not until about 10 years later, however, that artificial refrigeration was used in connexion with large shallow pans with brine coils for chilling and settling the oil-wax solution. This positive method quickly superseded the crude settling practice. The next step was the use of double vertical cylindrical tanks with cold brine circulation between the two shells, followed in about 1910 by ordinary vertical insulated tanks with pancake coils in the top for cold brine or ammonia circulation. A further natural development was the obtaining of a lower cold test



FIG. 5 Forty eight inch plate and frame wax press showing workers scraping off cheese or slack wax cake.

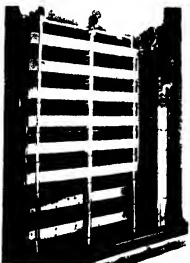

FIG. 6 Sweater or sweating oven for separating oil from wax. A wire mesh screen below the heating papers shown in each pan supports the solidified mixture of wax and oil while a selective melting of oil and soft waxes is carried on.

by the use of more cooling surface, first a second and then a third pancake coil being added, cold tests of the order of 40° to 45° F being obtained. This method held forth until about 1920, when centrifugal separation, effected by the use of the Sharples high-speed centrifuge, was introduced to the petroleum industry by Max B. Miller and P. T. Sharples, yielding in the early operations Bright Stock with cold tests of 25° to 35° F. An interesting incident in this connexion was the action of one refining company, unwilling to adopt the centrifuges, which continued with the tank and coil method by installing additional cooling surface with limited improvement in cold test and yields until a total of seven or eight pancake coils were used in each tank, before succumbing to the superiority of the Sharples process. Gray, in his *History of Bright Stock Manufacture*, describing the early development of the centrifugal idea, speaks of personally cranking a cream separator before the year 1900 for long periods of time, trying unsuccessfully to separate wax from oil. He tells of the designing in 1915 by P. T. Sharples, a manufacturer of centrifugal cream separators, of a high-speed machine with enough centrifugal force (17,000 to 18,000 r p m) to magnify the difference in specific gravity between the wax and the solvent sufficiently to cause separation in the presence of a carrier liquid consisting of calcium chloride. Several early commercial installations were made in 1920 and 1921. Gray describes the overcoming, at the 25-unit plant at Ponca City, Oklahoma, owned by the Marland Oil Company (now the Continental Oil Company), of two serious problems engendered by the use of calcium chloride, one, corrosion of equipment, and the other, cloudy appearance of the finished oil due to dissolved traces of calcium chloride. These difficulties were both solved by the one step of using hot water in the top of the centrifuge to melt and flow out the wax as it was separated, eliminating thereby the necessity of using the calcium chloride.¹

While for the first 20 years of Bright Stock manufacture practically entire dependence was had on Pennsylvania crude, the increasing demand and the expansion of refining activities west of the Appalachian region ultimately led to its manufacture from Mid-Continent crudes. Drs. Burton and Humphreys and associates of the Standard Oil Company of Indiana are given credit by some authorities for making the first Bright Stocks from non-Pennsylvania crude. One of the earliest Mid-Continent refineries to make it from Oklahoma crude was that of the Pierce Oil Corporation at Sand Springs, Oklahoma, in which Bright Stock manufacture was started in 1917-18. Gradually methods of acid treating and neutralizing as an aid to the orthodox filtration were evolved, and to-day the amount of Bright Stock produced from other types far exceeds that made from the Appalachian crudes.

Quite early in the history of the growing demand for automobile lubricants it was found that oils refined by filtering and without chemical treatment were the more satisfactory, hence refiners of Pennsylvania oils which could be economically so finished had a considerable initial advantage over those making lubricating oils from source material incapable of being refined by filtering alone. Work done by T. T. Gray, chief chemist of the Tide Water Oil Company, during the period from 1910 to 1915, disclosed that the sulpho-acid compounds set up in the orthodox chemical treating of lubricating oils were not eliminated by filtration through fuller's earth or bone char, nor was he able to discover any substitute for caustic soda for neutralizing purposes which would effect the desired results. The by-

products of sulphuric acid treating broke down very easily under the temperature conditions met in motor lubrication. A heat treatment to break up these unstable compounds before final filtration was the only solution available at that time, and this led to the practice of treating the distillates containing lubricating oil very heavily with sulphuric acid, the subsequent distillation of the treated product breaking up and removing the undesirable compounds so that after very costly final filtration a stable motor lubricating oil was the result. This problem of stabilizing without redistillation was later solved by the efforts of Paul W. Prutzman, J. W. Weir, J. C. Black, C. W. Stratford, and others in the development of the 'contact' method of filtration, involving the use of very finely ground fuller's earth, bentonite, &c., intimately contacted with the acid-treated lubricating oil, at temperatures ranging from 300° to 450° F, the effect of the temperature combined with the neutralizing, adsorbing, and catalytic action of the fuller's earth serving to break down and remove the unstable by-products of chemical treatment. Parenthetically, the same general deleterious effect of acid treating of cracked gasoline was early noted and such acid-treated gasoline had to be redistilled to make a satisfactory engine fuel. T. T. Gray, working concurrently in 1912 on the acid treating of lubricating oils and of cracked gasoline, discovered the basic principle underlying the now widely used Gray Vapour Phase treating method of refining cracked gasolines, by passing through fuller's earth in the vapour phase at elevated temperatures.

Another step of considerable economic influence in the manufacturing of lubricating oils, effected in 1915 and 1916, was brought about by the increasing demand for automobile lubricants, and made feasible by the greater availability of lower cold-test Bright Stocks. Tide Water Oil Company, adopting in 1914 the policy of national distribution of branded motor oils, faced the problems of improving the quality and increasing the output of their product. C. W. Stratford, experienced as a motor designer and familiar with automotive lubricating difficulties, was drafted from the automobile industry and joined his efforts with those of Chief Chemist T. T. Gray and Refinery Superintendent Walter Miller to the solving of these questions. What is believed to be the first motor-testing laboratory built by a refining company was then designed and installed at the Tide Water's Bayonne, New Jersey, refinery. Early work proved, contrary to a then accepted belief, that properly proportioned blends of comparatively low viscosity paraffin neutral oil with a well-refined Bright Stock were not only satisfactory but showed some advantages in use in internal combustion engine lubrication over the orthodox, narrow distillation range straight neutral oils. This led to 'straight-line production' of two base stocks, one consisting of an overhead neutral oil of somewhat lower viscosity than 'light' motor oil, the other a special Bright Stock with specifications suitable for the purpose, the two blended to meet the specification requirements of Light, Medium, Heavy, and other various grades of motor oils offered to the public. This practice made possible an increase of at least 50% in the potential output of paraffin-base motor oil and at the same time provided a favourable outlet for much of the Bright Stock output. Gradually adopted by others until it came into general use, particularly by refiners who made both neutrals and Bright Stocks, the method to-day furnishes the channel through which much the larger part of the Bright Stock being made finds its way to usefulness.

Chronologically, the foregoing review of early progress

in lubricating-oil manufacture has brought us to approximately 1922-4. The decade just passed had shown progress and growth surpassing any previous period. But more important, a foundation had been established for future growth based on sound scientific principles and knowledge, making possible the extraordinary development which has taken place since then. While the present-day art of refining is exemplified in detail in other chapters of these volumes, a general measure of the progress of the last 12 to 14 years can be made by comparing the principal lubricating oil refining operations *Then* with *To-day*.

Lubricating Oil Distillation Then The shell still was yet the main reliance of the refiner. Fractionation was still largely a matter of multiple distillation. The bubble-tower and vacuum-pipe still were just appearing over the horizon, although already envisioned as evidenced by then existing applications later eventuating into patents. A start had been made in shell still distillation towards the 'high vacuum' operation (below 25 mm absolute pressure, as exemplified by the Schulze method), but much the larger part of the vacuum stills were yet operating in the old limits of 50 to 100 mm absolute pressure. Almost all vacuum distillation was in the field of naphthenic and asphaltic crude operations, there being but little application to the manufacture of the much greater output of oils from paraffin and mixed-base crudes. While satisfactory neutral lubricating oils could be made from a wide range of available raw material, the limitations of the refining art necessitated the choosing for Bright Stock manufacture of a few selected crude oils in many cases involving premium prices and high transportation costs from distant fields.

Lubricating Oil Distillation To-day. To-day the refiner has at his command the combination of high vacuum pipe-still distillation, bubble-tower fractionation, efficient heat-exchanger systems, and modern instrumental control, all developed in the intervening period to a height of efficiency and a degree of perfection undreamed of *Then*, all working together to produce better and more uniform oil at a lesser cost from a wider range of raw material. Probably the most important single advantage of the modern installation lies in the fact that it enables the refiner to make the Bright Stock type of lubricating oils from almost any crude oil that will also make a satisfactory paraffin-base neutral oil. While selected types still possess some advantage over other crudes, this is so reduced that small differences in cost or availability will frequently throw the choice in favour of a crude oil formerly considered impossible as a source material. This change has effectually dispersed apprehensions formerly felt as to the future supply of raw material from which good viscous lubricants could be made, and greatly simplified the refiner's problem of what crudes to use.

The fractionation control afforded by the modernized bubble tower reduces redistillation to a minimum by making close specification products, and aids by controlling the quality of the wax-containing distillates so that the entire cut can be charged directly to the wax presses without resort to the intervening step, practised in whole or part in many plants, of redistillation in 'wax-cracking stills' to improve crystalline structure.

Among other improvements over the older art can be enumerated greater uniformity of both operations and quality, due to a maximum of instrumental and a minimum of manual control, improvement in flash-viscosity relationship and carbon residue of products, lessened subsequent chemical and filtration refining costs, &c.

The use of indirect heating of lubricating oil stocks in connexion with vacuum distillation has had considerable attention. Two installations were made in 1927, one by F X Govers at Lawrenceville, Illinois, using diphenyl as the indirect heating medium in making lubricating oils from wax-bearing crudes, and another by A E Pew, jun., at the Sun Oil Company's refinery at Marcus Hook, Pennsylvania, using mercury vapour for processing asphaltic base stocks. Despite claimed advantages over older methods, indirect heating did not meet wide favour, and in view of the much greater control of furnace and oil-tube temperatures available in the well-instrumented modern pipe still, there is little likelihood of further installations along indirect heating lines being made or justified.

It is impossible at this close range to attempt to identify individual contributors to this progress. While thousands of distillation patents have been issued during the intervening period, it appears to the authors that it was truly rather a period of general development and co-operation than of brilliant individual accomplishment, that it was a process of adaptation and aggregation of improvements in many small steps rather than fundamental and original discoveries. One outstanding feature apparent in a survey of the changes of the last 12 years is that to a greater extent than ever before were contributions made to the refining art and technique by those organizations known as the equipment companies, which to-day are playing such a large and important part in research, development, and engineering work being carried out by and for refiners.

Dewaxing Then and To-day.

Dewaxing Then While the frame and plate presses, sweating ovens, and tank sweaters continued to hold sway in the field of crystallizable wax, the Sharples centrifuge method was being installed in all parts of the world, both in new plants and in replacement of the older settling installations. The continuing downward march of the pour test was being indicated by the manufacturing and marketing of lubricating oils of lower than 20° F specification, as the public demand for easier starting of automobiles became more pronounced, and the contribution to this end of oils with lower wax content and greater fluidity at low temperatures more widely recognized. But the sharp limitations of both the pressing and centrifuging methods to crystalline and 'amorphous' wax respectively still held.

Dewaxing To-day Little mechanical or operating improvement has been made during the last decade in the pressing method and the Sharples centrifuging process (both now on the wane). In response to the demand for lubricants with low fluidity for the automobile, the industry is to-day producing the great bulk of the lubricating oils with pour-points of the order of zero to plus 5° F. Because of greater refrigerating requirements and lower throughputs per machine involving added investment and some increase in operating costs, refiners generally were reluctant to make the change, but after Dr E R Lederer, in the Texas & Pacific Coal & Oil Company's refinery at Fort Worth, Texas, changed his operation to produce and offer to consumers airplane and automobile lubricating oils with a pour test of 5° F, his lead was quickly followed, and in a comparatively short time the lubricating-oil manufacturer not in a position to offer similar products was at a distinct disadvantage.

To-day, in addition to the above methods of pressing and centrifuging, we have the newer 'solvent dewaxing' processes using materials as solvents much more selective



FIG 8 Battery of De Laval centrifuges used in the Bensol solvent dewaxing process Installation at refinery of Continental Oil Company at Ponca City, Oklahoma (Note frosted surfaces of machines in use)

in their action than the gas-oil content of the wax distillates processed through the plate presses, or the naphtha solvent of the Sharples centrifuging operation. These processes do not suffer from the old limitations, successfully handling either crystalline or amorphous types of waxes or mixtures thereof. Four processes are commercially available to the refiner. One uses propane as the single component solvent, another tri-chlorethylene. The other two employ a two-component solvent, the constituents chosen respectively for solvent action on the oil and an antisolvent action on the wax. One of the two latter processes utilizes a solvent heavier than the oil and wax in connexion with a centrifugal separation, the other a lighter solvent with a rotary filter extraction method.

The twenty or so plants now in commercial operation have been installed largely as added capacity rather than replacement of older equipment. While it is generally thought that all future new dewaxing installations will be of the solvent type, not many refiners are justified in the present state of the art in replacing operable existing pressing or centrifuging installations. Proponents of the new processes confidently assert that the additional experience and fundamental knowledge to be gained from the installed and contemplated large-scale operations will bring about improvements that will soon justify the replacing of all but the more efficient of the older installations.

The first commercial solvent dewaxing plant was built in 1927 to operate under the Govers patent, using acetonebenzol as the solvent, the installation being made at the Lawrenceville, Illinois, refinery of the Indiana Refining Company, later acquired and now owned by the Texas Company.

Early installations of the propane solvent-type plants included one at the Standard of Indiana refinery at Wood River, Illinois, in 1933, another at the Union Oil Company's plant at Oleum, California, in 1934, and a third at the Shell Oil refinery in Wood River, Illinois, in 1935. Much the greater number of plants at present installed and under construction are of the two-component type.

Two installations were made of the Weir dewaxing process (U.S. patents 1,509,325 and 2,005,062), one by the Texas Company at Port Arthur, Texas, in 1928, and the other by the Tide Water Oil Company in 1929 at Bayonne, N.J. This method, although using naphtha as a diluent, is not considered a true solvent process, but relies on the aggregating effect of fuller's earth, diatomaceous earths, or other filter-aid materials to facilitate the separation of solidified wax particles from the chilled diluted wax-bearing oils. The operation was apparently not successful enough to compare favourably with the new solvent processes, as no further installations have been reported.

Chemical Treating and Decolorizing Then and Now.

Lubricating Oil Treating Then. The technique of treating the heavy mixed-base residual stocks with sulphuric acid had been greatly improved, permitting the abandonment of the expensive method, fairly widely used for a few years, of treating the heavy oils in gas oil or naphtha solution. The difficulties in proper neutralization of both residual and overhead oils were being overcome, as manufacturers followed the earlier lead of the Californian refiners and resorted to 'contacting' filtration. The action of the finely divided fuller's earth or equivalent, directly dispersed in the acid-treated oil at elevated temperatures, was relied on to perform the triple function of neutralizing the product,

eliminating the objectionable derivatives of acid treating, and completing the decolorization to required standards. Differences of opinion existed as to the relative advantages of combined contacting and percolating versus the use of contacting only. Stronger than normal sulphuric acid (98% and fuming) was being used in the treatment of refractory raw materials. The value of 'hot' (200-300° F.) percolating filtration of Bright Stocks as the final refining step had considerable acceptance. Possibilities of 'solvent refining' were little more than a dream in the minds of a few of the technologists and no important changes seemed imminent.

Lubricating Oil Treating Now. To-day the refiner building a new plant, spurning the older methods, would choose a 'solvent treating' process and select one of at least eight available methods. As in solvent dewaxing, there are both single solvent and two-component processes. Lower installation costs, cheaper operation, larger yields, better-quality products, lesser degradation, both qualitatively and quantitatively, are all asserted in favour of the new against the old. Progress in the older methods in the interval has been negligible and little interest in attempting to improve them is now being shown, although still largely predominant in volume of production.

The list of the various solvents is rather bewildering—including such combinations as sulphur dioxide-benzol, and cresylic acid-propane in the two-component group, and nitro-benzene, phenol, furfural, propane, and beta-beta-dichlorethylether (chlorex) in the single-solvent class.

The earliest commercial solvent-treating plant was installed in 1924 by the Associated Oil Company, now a subsidiary of the Tide Water Associated Oil Company, at Avon, California, using sulphur dioxide for treating kerosene from the California naphthene-asphaltic base crudes, as developed by Dr L. Edeleanu. Success in extending the operation to the making of transformer oils in 1926 proved to be an intermediate step to the first commercial solvent treating of lubricating oils in the United States as such operations were instituted in July 1927, after some enlargement and slight alterations. The principal object of Associated was to develop, if possible, an oil from Californian crude stocks of such quality that it would decrease the demand for eastern lubricating oils on the Pacific seaboard. Considerable improvement in lubricating-oil quality resulted, particularly in respect to stability and freedom from sludging characteristics. In 1929-30 the Tide Water Oil Company, also a subsidiary of Tide Water Associated, installed a similar unit at Bayonne, N.J., used principally for special products such as turbine oils, &c. While sulphur dioxide as a single-component solvent was quite satisfactory on wax-free stocks, it did not work so well on wax-bearing materials, which led to the development of the combination with benzol as a two-component solvent in 1931 or 1932.

Early history was made by a number of 'first' installations, a phenol plant at Sarnia, Canada, in 1930 by Imperial Oil, a chlorex unit by Standard of Indiana in 1932 at Casper, Wyoming, a furfural operation by the Texas Company at Lawrenceville, Illinois, a duosol (cresylic acid-propane) unit at Paulsboro, N.J., by Socony-Vacuum in 1934 after a year's operation of a pilot plant, the nitro-benzene installation of the Atlantic Refining Company at Philadelphia, &c.

At present there are approximately twenty plants in operation in the United States, and the number will be considerably increased in the near future by other units under construction and projected.

The principal motive force behind this rapid commercial development was again the need for better lubricants, engendered by changes in automobile engine design involving higher bearing pressures, engine speeds, compression ratios, and operating temperatures. Lower sludging and carbonizing tendencies, greater resistance to oxidation, less increase of viscosity at low temperatures, are the ends continually being sought. Solvent treating has made important contributions in respect to sludging and carbonizing, and viscosity-temperature relationship, but has brought into the situation a new problem involving oxidation and consequent increase in acid formation. Apparently the reduction of the sludging and carbonizing constituents also removed some elements which had an inhibiting effect on acid formation. This phenomenon had previously been observed in the super-refined oils of the medicinal type, which under certain conditions develop comparatively colourless organic acids. This difficulty has led to the development in 1936 of special inhibitor-type materials, which, added in small proportions to the oils, apparently cure the difficulty, but, being expensive, affect the economy of solvent-treating operations. Much intensive thought is being given the problem, but in the opinion of the authors its appearance was to some extent responsible for the lessened rate of new installations during 1935.

The greatest stress has been placed on the improvement in the viscosity-temperature relationship. The advantage in an internal combustion engine of a lubricant which, while possessing suitable viscosity at normal operating temperatures, still retained sufficient fluidity in cold starting to ensure lubrication, had long been known. Recognized as one of the most important factors in the struggle for supremacy between paraffin-base oils and the more cheaply and easily made products of asphaltic crude source, the viscosity index (v_i) chart and formula developed by Dean and Davis of the Standard Oil of New Jersey Development Company, and announced by them in 1929, greatly widened knowledge and appreciation of this important characteristic. Their very useful contribution was quickly adopted by the refining industry and taken up by automotive engineers, and the greater ease with which viscosity-temperature relationship comparisons could be made and simply and clearly stated, served to dramatize and make more widely appreciated the advantages possessed by a lubricant having greater resistance to viscosity-temperature changes. The announcement was well timed, in that the Standard of New Jersey was preparing to effect v_i improvement through two important channels, viz by phenol solvent-treating at the Sarnia refinery of its Canadian subsidiary and by hydrogenation at Bayway, N.J. The Dean and Davis announcement was followed by work of other investigators and resulted in the publication of much additional data and the development of specialized charts facilitating interpretation and usability of the principle. An amplification in 1932 by the original authors in collaboration with Lapeyrouse, at the same time reviewing the work of other investigators, crystallized and focused interest on this point to such an extent that it became one of the most telling arguments in favour of solvent treating, and a spur to discoveries in the widening field of solvents.

There was some early apprehension on the part of refiners processing Appalachian and Mid-Continent types of crude, as to the possibility of solvent refining so improving the v_i of lubricating oils from asphaltic crude sources as to make them a potent competitor with respect to this quality factor. Such fears waned as investigation

indicated extremely low yield and consequent high cost of high v_i products from asphaltic starting material.

It is questionable whether a v_i competitive situation similar to the 'octane race' in the gasoline field is in the making, but it is significant that at least three refiners of Pennsylvania crude are using solvent-treating processes and turning out a product with a v_i higher than is commercially practical for the solvent-refining manufacture of oils from Mid-Continent-type crudes.

Lubricating Oil Addition Agents Then and Now.

Addition Agents Then. While the industry-old practice of adding lard, rape, castor, and other oils to mineral lubricants in proportions of from 5 to 25% might be considered as addition-agent practice, the term is used by the authors as excluding the above but embracing the modern development, using highly concentrated synthetic and special compounds of such effectiveness that only minute increments are needed.

Lubricating oils improved by adding extremely small quantities of oleic acid, derived from either lard or cottonseed oil sources, were being sold by the Marland Oil Company (now Continental Oil Company), which organization in 1922 had acquired the North American rights from Wells & Southcombe to 'Germ Processed Oils'. The discovery by Wells & Southcombe that the presence of organic fatty acids in animal and vegetable lubricants accounted for most of the differences in oiliness and lubricating quality between these lubricants and petroleum oils, and that minute additions of oleic or other organic fatty acid would impart a surface-wetting ability or 'oiliness' to mineral oils closely comparable to that possessed by the other type, furnished the first logical explanation of a phenomenon which had been recognized and acknowledged from those early days when petroleum oils first assumed importance. Wells published in 1903 a book entitled *Cylinder Oil and Cylinder Lubrication*, with an introduction by Professor Hele-Shaw, describing his early endeavours. Aided by Southcombe, success crowned his 20-year effort in 1918, but knowledge of the discovery was 'interned' by the English Government until some time after the conclusion of the World War, and its advantages were not made available for general use until 1920.

Addition Agents Now. To-day various addition agents are used for imparting new or improving existing characteristics of mineral lubricating oils. Compounds for improving oiliness and film strength, for lowering cold test, for raising viscosity and viscosity index, and for inhibiting organic acid formation in crankcase oils (already referred to under Solvent-treating Now) are to-day available to the refiner.

In the field of oiliness and film-pressure improvement, methylchloro-stearate supplanted oleic acid in 1934, as tests proved that the addition of less than 1% to a mineral oil not only improved oiliness but also more than doubled the film-pressure strength. This new synthetic compound, developed in the laboratories of the Continental Oil Company, has the added advantage over oleic acid of being practically non-corrosive to the new bearing materials such as copper-lead, cadmium alloys, &c., thus overcoming a fatal defect of the pioneer oleic acid addition agent, which attacked the new alloys with vigour and dispatch. Chlorinated diphenyl ether has been in wide use for a number of years. Chlorinated diphenylene oxide has had limited application. Chlorinated petroleum waxes and petroleum oils have proved useful in high-pressure gear lubrication,

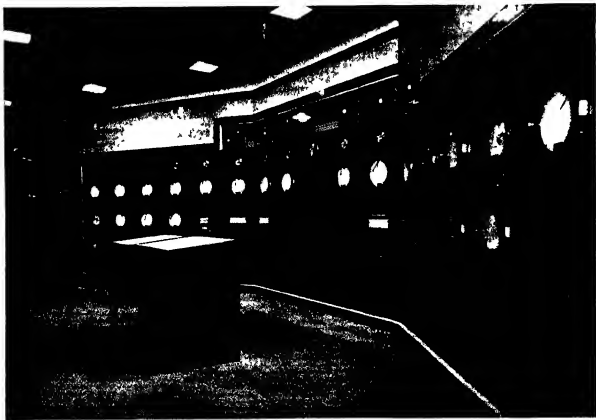
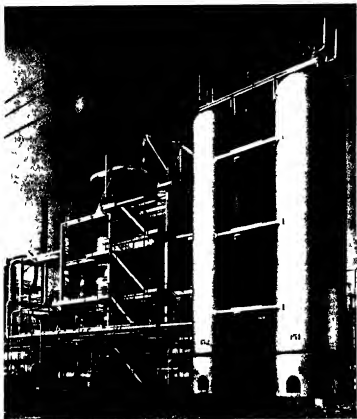

FIG. 10 Instrument room showing instrument board for recording and controlling operations of a new 32 000-barrel combination cracking and skimming unit Installed at Beaumont, Texas, refinery of Magnolia Petroleum Company (Socony-Vacuum)

SOME IMPORTANT PHASES OF PETROLEUM REFINING IN THE UNITED STATES

although inherently too unstable for successful use as crankcase lubricants Tri-cresyl phosphate came into use as a film-pressure improving agent late in 1934, at which time the Atlantic Refining Company incorporated it in their line of automotive lubricants Oxidized petroleum compounds manufactured under patents issued to A W Burwell for improvement of oiliness have had considerable use, largely in somewhat specialized fields

Advancing knowledge of the mechanism of lubrication, and the greater oiliness and higher film-strength qualities needed for the increasingly severe requirements of the internal combustion motor are the driving forces which are responsible for intensive research and testing work being carried on by dozens of laboratories and groups of technicians, both in and out of the industry

Pour-test control by use of crystallization inhibitors seems to have originated in the development of the well-known synthetic compound, Parafflow, by G H B Davis of the Standard Oil Development Company, patented in 1931 and in wide use to-day A patent to MacLaren of the Standard Oil of Indiana covered a somewhat similar product issued in 1934, both patents describing condensation products of chlorinated petroleum wax and naphthalene, with a slight difference in final composition

Viscosity index and viscosity improvement by use of an addition agent is one of the newest developments, and the principal compound available to-day is again a product of the Standard Oil Development Company, called Exanol in the concentrated form, and offered to the industry in the form of a 25% solution under the trade name of Paratone It is a high molecular weight compound made by polymerization of light gasoline fractions, according to a paper by G H B Davis and others published late in 1934 The effect of small additions in increasing both viscosity and v_1 is remarkable, and it is being utilized extensively by Standard Oil The product is still too new (it was made available to refiners in 1935) to foretell its future importance It is not as yet in wide use Whether Paratone will become directly competitive with normal solvent refining to any great extent is not as yet indicated, but in the event of an intensive ' v_1 race' developing, its importance as an adjunct to solvent refining and hydrogenation will undoubtedly be increased thereby

Voltolization as a means of improving v_1 and viscosity, involving the treatment of petroleum or preferably fatty oils with the silent electric discharge, bringing about various reactions during the process resulting in great increases in viscosity and resistance to temperature-viscosity changes, has been practised to a considerable extent in Europe for 10 or 15 years but has not obtained a foothold in the United States

The accomplishments in this addition-agent field in the last 5 or 6 years have come about so quickly that they must be considered as but a forerunner of future developments To those who have apprehensively observed the ever greater and more stringent demands on lubricating oils called for by engineers and designers of this machine and motor age as they pursue their endless quest for perfection, the progress already made is an assurance that future requirements will be met Whether the operating refiner, building in the future on the present foundation of vacuum distillation, solvent dewaxing, and solvent refining, will be the main contributor in meeting new needs as they arise, or whether the group comprising the research scientist, the organic chemist, the imaginative builder of new compounds, will

play the more important part, is an interesting speculation, unanswered as yet

Some other Phases of the Refining Art

While space does not permit an extended or comprehensive historical review of other phases of refining, interesting though many of them are, a partial review is here presented which it is hoped will at least serve as a background for progress made along some other channels

Gasoline Manufacture.

While the manufacture of gasoline is described elsewhere in these volumes in connexion with cracking, polymerization of gases, and recovery of liquid products from refinery and oilfield gases, this phase of the industry also has had an 'addition agent' development resembling the experiences in the lubricating oilfield, led by Dr Thomas H Midgley's discovery of the anti-knock property of tetra-ethyl-lead in 1922 This was followed in 1927 by the use of anthracene as a colour deterioration inhibitor, discovered by Dr A P Bjerregaard (since supplanted by more efficient compounds developed by the du Pont laboratories) From this start grew interest in agents for prevention of gum formation, and with the institution of the oxygen bomb stability test for gasoline by the United States Government in 1932, the practice of using such inhibitors increased materially, the more important compounds in use to-day being alpha-naphthol, catechol, dibenzyl aminophenol, monobenzyl-paraminophenol, and wood-tar distillates

In cracked gasoline treating the well-known Gray vapour-phase process has widely supplanted the older sulphuric acid practice in fields where desulphurization was not involved Variations in the use of fuller's earth, following the Gray discovery, included the high-temperature, high-pressure liquid-phase Osterstrom method and the process developed by R K Stratford, involving a treating tower in which a rising column of gasoline vapours contact against a descending slurry of oil and fuller's earth Two comparatively new methods of vapour-phase refining, each with some commercial application, are the Lackman and the Day processes The former, developed by A Lackman, uses zinc chloride instead of fuller's earth, and the latter, worked out by Roland B Day, relies on the chemical action of brass turnings in the presence of hydrochloric acid Where desulphurization is indicated, sulphuric acid still holds its position strongly, although some commercial use of superheated vapour-phase treating in the presence of fuller's earth is being initiated, several investigators having patented operating steps of this type The C W Stratford centrifugal method of momentary application and quick separation of the chemicals, and the low-temperature treating method developed by R A Halloran of the Standard Oil Company of California, both processes using sulphuric acid, have individually proved their value in commercial plants An installation including the advantageous features of both the Stratford and Halloran developments has recently been completed, and the outcome of the combination will be of interest to all refiners with high sulphur content gasoline problems

Of the number of new methods of 'sweetening' gasolines proposed in recent years, few have made any commercial headway Brucite (magnesium hydroxide) is employed in two or three refineries Various forms of metallic salts, principally of copper derivation, have been studied, and several plants have been installed recently and are in

successful operation, using copper chloride either in solution or in the dry state, the latter in the form of fuller's earth impregnated with the copper chloride. The use of hypochlorite advocated in 1922 by A. E. Dunstan and B. T. Brooks has had but little application in refineries but is in fairly wide use in natural (casing-head) gasoline operations. Undoubtedly much wider commercial use would have resulted of methods other than the classic 'doctor treatment' employing sodium plumbite had it not been for the discovery made independently of each other by several refinery organizations, of an inexpensive method of recovering a large percentage of the lead oxide after use. While the early commercial work in 1926 and 1927 was none too efficient, it is possible now to recover well over 90% of the lead oxide. Many refineries installing recovery plants were fortunate in having on hand doctor sludge accumulations of prior years, available for lead oxide recovery, and were enabled thereby to rely on such accumulations for their reduced 'make-up' requirements for long periods.

Much progress has been made in conservation of gasoline evaporation losses, well described in Bureau of Mines Technical Bulletin No. 565 by Ludwig Schmidt and C. J. Wilhelm. Older practices such as shielding of tanks against the sun's rays, spraying of tank roofs, interconnecting of active tanks with vapour lines to equalize 'breathing', &c., have been augmented or replaced by floating roof tanks, pressure-storage tanks of the spherical and spheroidal types for the highly volatile products, and the Wiggins 'breather' balloon, these latter developments being largely the result of the efforts of John H. Wiggins in conjunction with the Chicago Bridge & Iron Works. Stabilization of crudes before refining, stabilization of gasoline for elimination of propane, storage of highly volatile fractions in pressure tanks, and blending with less volatile fractions only as needed for shipment, all are contributing to a material reduction of an item of refining expense which was for many years disregarded or meekly accepted as an unavoidable burden.

Metallurgical Contributions to the Refining Art

No one familiar with early refining engineering and construction can fail to be amazed at the contributions of metallurgy to the present state of the art. Compared with the days when lead for lining acid-treating vessels was the principal metal used outside of iron and steel, the list of alloys in use to-day is illuminating as to the progress made. Steels alloyed with varying proportions of chromium ranging from 2 to 26%, largely for corrosion resistance, with small increments of molybdenum or columbium for greater creep-strength value and embrittlement prevention, with the further addition in the higher percentage alloys of substantial proportions of nickel (making stainless steels) for very high temperature and pressure conditions, have played a highly important part in the progress made in recent years in cracking, reforming, and polymerization. (A much-used combination is 18% chromium, 8% nickel, $\frac{1}{2}$ % molybdenum or columbium, the remainder low-carbon steel.) Used mainly in still tubes and headers, extensive applications are made in valve and pump parts, in fact, in all areas where high temperature, high pressure, and corrosive conditions are met with. While very expensive (the specific alloy mentioned above costing from ten to fifteen times as much as low-carbon steel), the savings in repairs and replacement, and the higher returns which can be attained as a result of the better operations made possible,

justify the increased initial cost in many cases, and account for the continuing use of such materials.

The maintenance engineer's lot has also been made easier by progress in the developing of cast-iron alloys. High silicon content material, non-machinable but very resistant to corrosion and abrasion—cast iron alloyed with nickel and silicon in suitable small percentages to fit the needs of various uses, readily machinable and therefore widely applicable—a high corrosion-resistant combination of nickel, copper, chromium, and manganese in cast iron (Ni-Resist) used extensively for condensing sections, pump casings, valves, and piping—all are contributing to lower maintenance costs, longer runs, and more dependable operating conditions.

Similar advances have been made in the application of non-ferrous alloys and metals to problems involving corrosion and acid action in condensers and exchangers, valves, tubing, pump parts, &c., for protection against deleterious effects from liquids and vapours at high temperatures and low. In this field Admiralty metal, red brass, copper-nickel-aluminum alloy, monel metal, aluminum, and lead have each proved to be the answer to one or more specific corrosion or service problems.

Its well-recognized resistance to corrosion by sulphur compounds has occasioned widespread research in the application of aluminum to high temperature and pressure conditions. 'Calorizing', or the impregnation of steel surfaces such as tubes or plates with metallic aluminum, was a development of the 1920's which found considerable application, particularly before the advent of the chromium alloys. A more recent development is 'metallizing', a process applicable to many metals and alloys, but which the refining industry has found especially useful in applying aluminum coatings to interiors of drums and chambers. 'Metallizing' involves the spraying of a molten metal or alloy on the surfaces to be coated, the metal being deposited in the form of a thin dense film, relatively impervious, as a protection to the underlying metal.

An even more recent development, already fairly well tested but not as yet generally available, is a process called 'Ihrgizing', developed by Dr. H. K. Ihrg of the Globe Steel Tubes Company of Milwaukee. It is a method of driving pure silicon into fabricated iron and steel articles to form an impregnation or 'case' of almost any desired thickness. Concentrations are claimed up to approximately 14% silicon content, integrally part of the treated area. Giving promise of future availability at substantially lower costs than most of the corrosive-resistant products now on the market, iron and steel parts so treated have shown high resistance to dilute nitric, sulphuric, hydrochloric, phosphoric, and acetic acids in service tests.

Electric Arc Welding in Construction and Maintenance of Refineries.

Outstanding in the great general progress in construction and maintenance practices was the rapid advance in the utilization of electric arc welding. While emerging from the experimental stage a few years earlier, refiners made little or no use of it until about 1925, when after a rather diffident introduction in the industry it rapidly found a place and soon became one of the main reliances of the construction and maintenance engineers. First used largely for repair work done previously by the acetylene torch and the forge, rapid improvements in welding machines and technique enlarged the field far beyond the possibilities of the older methods.

The pioneering and early development work of the A. O. Smith Corporation of Milwaukee, Wisconsin, in the making of heavy walled reaction chambers and towers for use in high-pressure and temperature cracking processes, replaced the products of hammer welding and forging which had only a short time before constituted the first departure from the ages-old practice of riveting.

Used in innumerable ways to the displacement of bolts, rivets, screwed joints, &c., it has had a direct effect on engineering design of equipment, and is particularly advantageous to the refiner in the fabrication of piping systems, whether in stills, exchangers, or for long- or short-distance transportation, making for smoother flow of liquids, elimination of many fittings, lessening leakage possibilities, &c.

Metallurgy entered into the picture, and welding-rod materials have been developed permitting the use of arc welding in the fabricating of many types of alloy materials. The use of the shielded arc, the proper rate of application of the weld metal, the release of stresses by annealing, the selection of the proper welding-rod metal, the development of the X-ray method of inspection of welding work, are all factors of importance in broadening the field of this tool of the constructor, a field which runs the gamut between the joining together of hair-thickness wires to the cutting apart of a mighty ocean liner and welding in an extension section to make it a still larger ship.

Modern Instrumentation.

One of the most valuable contributions to the progress of the refining art has been the wonderful accomplishments of the instrument-makers. Compared with the thermometer and 'gravity stick' of the early-day refiner, the

development seems little short of miraculous. Concurrently and interdependently with the modern progress in refining, instruments have been built to measure, report, record, and control the steps of most of the operations carried out, whether in distillation, cracking, solvent-treating, or other applications. The more scientific any operation becomes, the more need for an accuracy of measurement and control of vital conditions in operation beyond the manual possibilities of the human operator. Such needs have been met as they arose and at times anticipated by the manufacturers, adding values to equipment and processes impossible to calculate. For illustration, one could not estimate how much additional man-power would be required in the operation of a large combination unit were manual control of temperatures, rates of flow, pressures, liquid-levels, &c. required, because of the difficulty of conceiving such an operation. Visualizing the 200 or more points of measurement and control which would have to be observed, interpreted, and correlated concurrently with the flow of oil through the unit, it is easy to reach the conclusion that without the automatic, instantaneous control afforded by modern instrumentation, the development, installation, and operation of at least the large combination units would have been impossible, and the status of the refining art in general that of a decade or more ago. Surpassing all labour-saving, however, are the other advantages added to the refining art, in the form of improved yields and better product values, longer life and operating time of equipment, lower investment cost because of greater throughput per unit of installation, and the elimination of many hazards of operation necessarily accompanying dependence upon the human equation in manual control.

SELECTED BIBLIOGRAPHY

BOOKS AND PAMPHLETS

- BACON, R. F., and HAMOR, W. A. *American Petroleum Industry* (McGraw-Hill, 1916)
- CAMPBELL, A. *Petroleum Refining* (C. Griffin & Co. Ltd., 1918)
- ELLIS, C., and MEIGS, J. V. *Gasoline and Other Motor Fuels* (Van Nostrand, 1921)
- INSTITUTE OF Petroleum Technologists. *Petroleum—25 Years Retrospect* (1935)
- KALICHEVSKY, V. A., and STAGNER, B. A. *Chemical Refining of Petroleum* (Chemical Catalog Company, 1933)
- LEET, A. N. *Petroleum Distillation and Modes of Testing Hydrocarbons* (1884)
- LESLIE, E. H. *Motor Fuels* (Chemical Catalog Company, 1923)
- PROCTOR, A. C., and EGOLOFF, G. *Instrumentation in Oil Refining*, Booklet no. 184, Universal Oil Products Company
- REDWOOD, B. *A Treatise on Petroleum* (Lippincott, 1922)
- ROCHEA, A., and AUBERT, A. B. *Industrial Chemistry* (Van Nostrand, 1912)
- SCHMIDT, L., and WILHELM, C. H. *Reduction of Evaporation Losses from Gasoline Bulk-storage Stations*, U. S. Bureau of Mines Technical Paper 365
- WADSWORTH, J. M. *Removal of the Lighter Hydrocarbons from Petroleum by Continuous Distillation* Bulletin 162, U. S. Bureau of Mines

ARTICLES

- BOTSFORD, H. *Forgotten Chapters of Oil History* *Refiner*, 6, 68 (Oct 1927)
- CLARK, G. L., LINCOLN, B. H., and STERRETT, R. R. *Fundamental Chemical and Physical Forces in Lubrication* *API*, *Sixteenth Annual Meeting* (Nov. 1935)
- DUNSTAN, A. E., and BROOKS, B. T. *Refining of Gasoline and Kerosine by Hypochlorites* *Ind. Eng. Chem.* 14, 1112 (1922)
- GRAY, McDOWELL. *The History of Bright Stock Manufacture* *Petr. Eng.* 130 (Nov. 1930)
- JOHNS, C. O. *The History and Status of Chemistry in Petroleum Research* *Ind. Eng. Chem.* 15, 446 (May 1923)
- NOTVET, R. *Modern Arc Welding Practice* *Welding* (June, July, Aug., Sept. 1934)
- Oil and Gas J.*, *Miscellaneous*, 23 (23 Aug. 1934)
- SILLMAN, B., jun. *Report of the Rock Oil or Petroleum from Venango County, Pennsylvania* *Amer. Chemist* (July 1871)

SECTION 23

CASING HEAD GASOLINE EXTRACTION

Gasoline Recovery by Charcoal Adsorption

T G HUNTER

**The Recovery and Stabilization of Gasoline from Refinery and
Natural Gases**

P D BARTON

GASOLINE RECOVERY BY CHARCOAL ADSORPTION

By T. G. HUNTER, Ph D., A.R.T.C., A.I.C., M.Inst.P.T.

Lecturer, Department of Oil Engineering and Refining, The University of Birmingham, England

ALTHOUGH the adsorbing properties of charcoal have been known for a very considerable time, its employment in industry is of comparatively recent origin. The properties of activated charcoal or carbon were first applied industrially to the decolorizing of solutions. Later on very large quantities of activated carbon were used as an adsorbent in gas masks for protecting troops against poison gas in the Great War.

The activated carbon adsorption process has been developed commercially during the last decade, for the recovery of gasoline from natural gas, in the United States and Europe, and for the removal of benzol from coal gas, in Great Britain.

Activated charcoal is a granular porous substance and forms a very good adsorption medium owing to its high specific surface.

Ordinary charcoal or carbon is made by the destructive distillation of organic compounds in the absence of air at comparatively low temperatures. The carbon deposited below temperatures of 500-600° C has adsorbent properties, while that deposited above 600-700° C has little or none. Further treatment, however, of low-temperature charcoal is necessary to convert it into a satisfactory adsorbent, since hydrocarbons formed during the carbonizing process are adsorbed by the charcoal, and render it inactive for gas-adsorption purposes. These adsorbed hydrocarbons are removed by preferential oxidation at higher temperatures, using a suitable oxidizing agent. During this process some carbon is also oxidized. This is, however, beneficial to a certain extent as the inside diameter of the capillaries in the charcoal are enlarged, and also new capillaries formed, thereby increasing the available surface. If this is continued too far, however, the walls of the capillaries get worn away, resulting in two or more capillaries joining up and thus eventually decreasing the surface.

As used for adsorption processes, the charcoal is in the form of small grains which will just pass through a 2-mm sieve. The presence of very small granules or dust must be avoided as they tend to be carried away by the gas passing through the adsorber. More serious still, they increase the pressure drop of the gas through the adsorber. The carbon must not, therefore, be friable.

Large grains of carbon produce large empty spaces between them, and as such voids are of no value in adsorption, the capacity of the carbon per unit volume is lessened.

The size and total volume of the capillaries are the main factor in determining adsorption capacity. The size of these capillaries range from 1 μ up to 100 μ . When recovering natural gasoline by charcoal adsorption these capillaries behave differently according to their sizes. The smallest capillaries (up to 2 μ) have a greater tendency to adsorb gas and are soon filled, even if the adsorbable gas concentration is low. Capillaries of larger size (2-100 μ) will adsorb larger quantities of gas, but will only be effective when the concentration of adsorbable gas is comparatively high. Capillaries greater than 100 μ are probably inactive in the adsorption process.

Manufacture of Active Carbon

The chief commercial methods of preparing activated carbon are as follows.

Bayer Process. The raw material, peat, sawdust, or other carbonaceous substance, is ground, mixed into a paste with a metallic chloride such as zinc chloride, and the resulting paste extruded through die presses to form rods of suitable diameter. These rods are then broken into short lengths, calcined in a rotary furnace, washed, sieved, and graded.

Urban Process. This is similar to the Bayer Process except that a solution of phosphoric acid is used in place of the zinc chloride. The paste is dried at about 500-600° C and finally subjected to a temperature of about 1,200° C. At this temperature, not only are complex hydrogen compounds destroyed, but the phosphoric acid is reduced to phosphorus which distils over. This phosphorus is burned, and the vapours of phosphorus pentoxide so produced are dissolved in water to regenerate phosphoric acid. The activated carbon is washed, dried at 300° C, and graded.

Steam Activation. Steam or gas can also be used for the production of activated carbon. The raw material, which is usually an already coked material such as wood charcoal or brown coal in pieces of the size of walnuts, is heated in a vertical retort to 800-1,000° C. This carbonized material is fed in at the top and falls continuously through the retort. After passing through the hottest part of the retort, which is fairly low down, it drops into a cooling chamber. At the same time steam, which is the activating medium, is passed upwards through the mass, the resulting water gas being used to heat the retorts. The product, when cool, is washed and graded.

Activity of Carbon

This is generally expressed either as weight or volume activity, i.e. percentage of gasoline adsorbed by respect to the weight or volume of the carbon.

The most usual method employed to determine the activity of a particular carbon sample is as follows.

A stream of benzene-air mixture of definite concentration, usually about 1/10th saturated (30 g per cubic metre) is passed through a definite weight of charcoal until no further increase in weight is noticed, the temperature being kept constant.

The required benzene-air mixture is obtained by passing air through a glass-wool filter and the rate so adjusted that about 15 litres per hour of air pass through a benzol saturator where it becomes saturated with benzol vapours. This saturated air is mixed with about 9 times its volume of pure air in a mixing chamber and then passed through a U-shaped adsorber containing the sample of activated carbon.

The weight activity of the charcoal is expressed as the

$$\frac{\text{Increase in weight of charcoal}}{\text{Original weight of charcoal}}$$

For an accurate comparison between different charcoals, however, their complete adsorption isotherms should be determined and compared.

Selectivity of Adsorption

When a mixture of gases is being adsorbed the process is selective, i.e. the heavier hydrocarbons present in the gas, which have lower vapour pressures, are preferentially adsorbed. As the gas passes through the charcoal bed the heavier components are adsorbed first, so that in the top layers of charcoal in the adsorber the lightest gases will be adsorbed and the residual gas leaving the top of the adsorber will not contain any high molecular weight constituents. On continuing the passage of gas through the adsorber the heavy components gradually replace the lighter already adsorbed until ultimately the whole bed becomes saturated with the heaviest constituent of the gas.

In practice the adsorption is stopped when the lightest constituent of the gas which it is desired to remove is being replaced by a heavier constituent and is in consequence appearing in the exit gas from the adsorber. This is called the 'break-point' of the adsorbent, and depends on the nature of the gases, on the temperature and partial pressure of gasoline vapours being adsorbed, and on the time of contact.

The selectivity of the adsorption process gives flexibility to natural gasoline adsorption plants and to the specification of the recovered gasoline, e.g. the gravity and initial boiling-point of the recovered gasoline can be varied according to the quantity of gas passed through the charcoal.

This is one advantage of this process allowing gasolines to meet different requirements and specifications to be produced. Conditions can also be controlled so that the gasoline is free from undesirable constituents and does not require stabilization or blending, but can be stored or transported without further treatment.

Temperature of Adsorption

During adsorption the activated carbon is heated up due to the evolution of the latent heat of condensation of adsorbed hydrocarbons. This increase in temperature, if allowed to persist, results in lower adsorption capacity.

This rise in temperature is checked to a certain extent by two factors:

1. The residual gas carries away some of the heat evolved.
2. Part of the heat is utilized in negative adsorption, i.e. the replacement of the lighter components already adsorbed by the heavier ones which have a lower latent heat of condensation, so that heat is removed from the system during this transformation.

When gasoline concentration is low sufficient gas usually passes through the adsorbent bed to keep the temperature down, but with high gasoline concentration it is necessary to keep the carbon cool by means of a coil through which cold water is circulated.

Adsorption Plant

Adsorption plants may be divided into two broad classes, the first having heating and cooling coils within the adsorber, and the second being without such coils. When dealing with gases rich in gasoline it is essential to use plants of the first type with cold water circulating through the coils during the adsorption period in order to keep temperatures low. For gases of low gasoline content the provision of such coils is not necessary, so that they are omitted on grounds of economy.

A typical plant containing heating and cooling coils is

shown in Fig 1. The gas enters adsorber *A* at the bottom, and passes upwards so that the bottom layers of activated carbon first become saturated with gasoline. This adsorption is accompanied by a rise in temperature which will gradually spread up the adsorber as saturation of the lower layers takes place. Hence the progress of adsorption may be followed by observing the temperature at various adsorber depths. In general the temperature is not allowed to rise above 50° C. The lean gas passes out at the top of the adsorber. While adsorption is in progress in adsorber *A*,

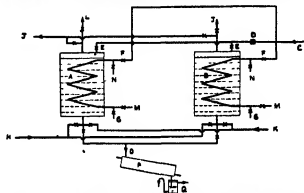

FIG 1 *A*, adsorber containing activated carbon, *B*, adsorber containing activated carbon, *C*, steam from boiler, *D*, reducing valve, *E*, direct steam inlet, *F*, indirect steam inlet, *G*, condensate outlet, *H*, gas inlet, *J*, gas outlet, *K*, air inlet, *L*, air outlet, *M*, cooling-water inlet, *N*, cooling-water outlet, *O*, gasoline-water outlet, *P*, condenser, *Q*, separator

adsorber *B* is undergoing regeneration whereby its adsorbed gasoline content is recovered. Steam at 2-3 atm is passed through the coil in *B*, thereby heating the carbon indirectly. After this operation has been in progress for some minutes direct low-pressure steam is blown into the adsorber from above. This direct steam carries away the adsorbed gasoline in vapour form to the condenser. The condensed gasoline and water then travel into a separator from which the gasoline passes into storage and the water to waste.

The next operation consists of drying and cooling the carbon. Direct steam is shut off while indirect steam continues to flow through the coils. Dry air is then passed through the charcoal from the bottom upwards and discharged to the atmosphere. To cool the charcoal the indirect steam is cut off and air blowing through the adsorber continued, assisted, if necessary, by circulating cold water through the coil. The adsorber is then ready for use again.

In the second type of plant without coils all heating during the regeneration period is done by direct steam. To dry the carbon bed after direct steaming preheated air must be passed through it. An air preheater is therefore a necessary part of the equipment.

In the adsorption plant, although all actual operations are batch operations, each cycle is continuous, i.e. when one adsorber is cut off from charging and put on steaming, another is cut off from steaming and put on drying, while a third unit is changed over from drying to cooling, and similarly another unit is cut off from cooling and is ready for charging again.

These processes constitute the plant-operating procedure, and it is the function of the designer to determine for a given gas, knowing its gasoline content, the most economical procedure to be adopted. In a plant having a large number of adsorbers considerable economies can be effected by

arranging operating times so that the steam, &c., requirements remain as nearly as possible constant. A typical example of an operating cycle for an eight-adsorber plant of the direct heating and cooling type is shown in Fig. 2. In general in any one adsorber the adsorbing time is equal to the total time of regeneration. In Fig. 2 there are, at



FIG. 2

any time, 4 adsorbers charging, 2 steaming, 1 drying with hot air, and 1 being cooled with cold air. In such a system, therefore, the steam and air requirements remain substantially constant.

The usual gasoline content of the carbon after adsorption in commercial units is of the order of 12-16% by weight.

Poisoning of the Charcoal

Certain impurities in the gas have the effect of 'poisoning' the charcoal and rendering it inactive for adsorbing hydrocarbons. One of these impurities is hydrogen sulphide, and the charcoal methods of gasoline extraction are not suitable for gases containing a high percentage of this substance.

Hydrogen sulphide can, however, be removed from the gas previous to adsorption by suitable treatment. Hydrogen sulphide and other sulphur compounds are adsorbed preferentially to hydrocarbons and hence may be removed

from the gas by adsorption with a lower grade of charcoal than that used for gasoline adsorption. Pure sulphur can be recovered from this charcoal on regeneration.

The success of charcoal adsorption of benzol from coal gas depends upon the working life of the active charcoal. Even after all hydrogen sulphide and naphthalene have been removed from the gas, poisoning of the carbon still takes place, largely due to gum formation. This gum, which is probably due to polymerization of unsaturated hydrocarbons present in coal gas, is not removed by steam distillation of the charcoal and its deposition is therefore cumulative. This polymerization appears to take place under the action of heat during the recovery of adsorbed benzol from the charcoal.

The presence of hydrocyanic acid in coal gas also causes depreciation of the charcoal and, moreover, the benzol produced in the presence of this acid tends to resinify on storage.

The life of activated charcoal can be considerably prolonged if the following precautions are taken:

- 1 The steam and gas pass through the charcoal bed in opposite directions. It then becomes more difficult for impurities of high molecular weight, which are adsorbed at the gas-entry end of the adsorber, to penetrate far into the charcoal bed.
- 2 Hydrocarbons should not be left in contact with charcoal any longer than necessary, and, in particular, benzol, if benzol is being recovered, should not remain in contact with charcoal whilst it is hot.
- 3 The gas should not be allowed to pass through the charcoal bed after the break-point has been reached. By this means, also, the penetration of impurities of high molecular weight is limited.
- 4 The gas entering the charcoal bed should be free from hydrogen sulphide and naphthalene.

SELECTED BIBLIOGRAPHY

BURRELL, G. A. *Recovery of Gasoline from Natural Gas*. Chemical Catalog Co., 286 (1925).

EVANS, K., PEARSON, H. F., and REISEMANN, E. *Trans Inst Chem Eng* 7, 134 (1929).

HOLLINGS, H., PERTON, S., and CHAPLIN, R. *Trans Inst Chem Eng* 7, 85 (1929).

PILAT, S. *J I P T* 18, 273 (1932).

THE RECOVERY AND STABILIZATION OF GASOLINE FROM REFINERY AND NATURAL GASES

By P. D. BARTON, B.Sc.
Sun Oil Company

Introduction

THE art of handling refinery vent vapours, cracking-still gases, and natural gases, for the recovery and separation of their valuable constituents, has reached such a stage of development that any comprehensive discussion of the modern engineering method of attacking the problem must disregard the boundary lines of the general processes of absorption, compression, and fractionation, and devote itself to the broader viewpoint of the economical accomplishment of a desired result. In other words, the engineer has available a number of *fundamental processes*, limited and controlled by certain natural laws as well as chemical and physical conditions, which may be used in combination in the development of an overall process to handle raw materials of an established range of quantity and composition, and leading to a specified separation of constituents.

There are certain *ideal results* which the industry is always striving to obtain in practice. In general, these ideals cover economy of operation and the specifications of products (particularly composition). Of course these ideals are constantly changing in certain respects as process refinements are made and utilization methods are improved. Also matters of marketability and market value of the various possible products largely influence economical considerations both in regard to first cost of the plant and the cost of operation and maintenance. There is no sharp line of demarcation between 'desirable' and 'undesirable' constituents in the final products of the recovery and stabilization plant, and considerable flexibility is necessary to meet the demands imposed by seasonal changes and other factors which influence product specifications and market demand. Thus the engineer must keep in mind that the desired result for which he is working includes not only high efficiency under the optimum operating conditions, but also the ability of the plant to operate without material loss of efficiency within a fairly wide range of gradually changing conditions.

In order to accomplish the desired result in a given case the design engineer must have training and information covering three separate groups:

(1) He must have a *thorough working knowledge of the fundamental natural laws governing the behaviour of the materials with which he is concerned*. Fortunately, the relatively small number of compounds involved has favoured the advancement of our knowledge of the chemical and physical reactions of both the individual compounds and their mixtures, so that it is possible to predict with reasonable accuracy the result to be expected under an established set of conditions. However, the infinite number of combinations possible introduces a complexity that renders the problem quite difficult. Also, the *limitations* on the functioning of the several principles are not so well known as the abstract principles themselves, and only recently has the charting of the resultant effect of the deviations from the expected behaviour of the various materials

as projected from the so-called Gas Laws been attended with any degree of success.

(2) He must have *experience with the actual operation of the basic principles involved*. In general, theoretical relationships do not indicate the physical limitations imposed by apparatus design and operating conditions beyond the control of the design engineer. In fact, there are pitifully few engineering formulae available which do not contain an all-important factor 'K' whose value must be determined (or assumed) before the problem can be solved. These factors may be called 'experience factors' and represent the combined effect of a number of influencing conditions inherent to the particular application under consideration.

(3) He must have *complete data with respect to the material to be handled, the limitations imposed by location, utilities, and natural conditions, and the final result to be accomplished*. Necessary information on the gases and vapours to be processed includes composition as indicated by careful fundamental analysis, pressures and temperatures at which each is available, normal, maximum, and minimum rates of flow, and relative continuity of flow, and the source and dependability of the supply in each case. Where past records are available, it is advantageous to classify the data and strike averages which will indicate normal and peak conditions which must be met in the plant. The limitations arising from natural causes, which include barometric pressure, seasonal temperature fluctuations, and humidity, often have a strong influence on design, as does also matters of location, limited plant area, possible hazards in the nearby vicinity, and, in some cases, restrictions imposed by law. The influence of utilities is chiefly economic. Where possible, accurate costs should be established for water (raw and treated), steam (high and low pressure), electricity, and fuel. Then, after preliminary estimates of the probable requirement, it is advisable to re-check to determine whether the new demand may be safely added to present loads and whether net costs are changed. This matter is quite important and requires careful consideration, balancing investment and fixed charges against continuing costs of operation. In addition to all the above limitations on the design of a proposed plant, the above are the very important ones of the desired process result—the justification for making the installation. Since, in most cases, the products of the recovery and stabilization plant are not finished products, i.e. they are not used directly, but are blended with other materials, it is obvious that specifications of these intermediate products are largely controlled by the requirements of the commodities of which they form a part. Considerable progress has been made in recent years towards standardization of gasoline recovery-plant product specifications, but individual circumstances dictate the conditions to be met in operation, and in order to design an efficient plant, the engineer needs the fullest possible information with regard to the variation in product specifications to be expected and special conditions which influence them.

Fundamental Processes

In designing vapour-recovery and stabilization plants the engineer uses three general fundamental processes: absorption, distillation, and fractionation. The scope of this article prohibits detailed treatment of these fundamental processes, and is confined to the discussion of their limitations and advantages, as well as certain special cases, modifications, and combinations which lead to the final accomplishment of the desired result in continuous operation.

Absorption

When a gaseous mixture is brought into intimate contact with a liquid in which any of its constituents are soluble there is a tendency towards a definite transfer of material between the gas and liquid, somewhat analogous to the transfer of heat between adjacent bodies at different temperatures. This phenomenon is known as *absorption*, and the physical operation of contacting a gaseous mixture with an absorbent liquid for the purpose of concentrating certain valuable constituents of the gas is known as the *Absorption Process*.

For a transfer of material to take place from the mixed gas to the absorbent liquid there must exist a finite 'driving force'. This force is the difference in the pressure relationship, partial pressure in the gas minus partial vapour pressure in the liquid, and must be considered from the standpoint of individual components. Thus it appears that data must be available on the composition, pressure, temperature, and quantity of the gas, on the composition, temperature, and molecular weight of the liquid, and on the vapour pressures and molecular weights of the individual components of both gas and liquid. When it is considered that in most vapour-recovery problems the mixed gas is comprised of at least five important constituents, the complexity seems enormous. But in actual practice certain conditions are either definitely established (such as gas pressure and source) or vary within known limits (such as cooling-water temperatures, quantities, and, to some extent, composition). Also the problem is further simplified by the fact that the absorbent medium may be selected with specific properties, and the distinction between 'desired' and 'undesired' constituents may be established. In nearly every case a *key constituent* can be selected, and it can be definitely stated that as much of that constituent is desired to be recovered as can be utilized commercially, provided the cost of the recovery is economic. Constituents which have a relatively lower vapour pressure than the key constituent are more easily absorbed (the driving force being greater for equivalent concentrations) and are also classed as 'desired' to be recovered. The relatively higher vapour-pressure constituents are more difficult to absorb and fall in the 'undesirable' group. In the field of gasoline recovery from natural and refinery gases there is another general fact which helps to simplify the problem. This is the fact that such gases possess 'type' characteristics in regard to their composition which reflect the *PVT* conditions at the source of the gas.

- The higher the pressure of the source of the gas, the 'leaner' the gas with respect to recoverable gasoline.
- The higher the temperature of the source of the gas, the 'richer' the gas with respect to recoverable gasoline.
- The relative quantities of the chief constituents in a given gas are usually inversely proportional to the molecular weight of the constituents (particularly

true if constituents of the same number of carbon atoms are grouped together, e. g. the 4-carbon atom group which may be called 'butanes' and includes normal and iso-butane and the several butylenes).

- Gasoline-bearing gases are usually produced along with liquid products from which they are separated by gravity, the larger the ratio of gas volume to liquid volume at the source, the 'leaner' the gas with respect to recoverable gasoline, other conditions being comparable.

The analogy of material transfer in absorption of gasoline constituents from a gas to the transfer of heat may be carried still further. As in heat transfer, the number of B Th U per hour transferred in a given case is the product of a transfer coefficient U , and the logarithmic mean temperature difference. So in the absorption process the quantity of a given constituent transferred from the gas to the absorbent liquid is the product of a coefficient and a mean pressure difference (driving force). In the absorption of gasoline constituents in the oil gas film is the controlling factor, and it is safe to use the logarithmic mean driving force calculated from the driving forces at the top and bottom of the absorber tower. The material transfer coefficient is affected by tower design and certain physical conditions such as interfacial velocity and oil-gas volume ratio, but usually such factors are fixed in a given instance. Another factor having a marked influence, and also one which is subject to considerable variation in practice, is that of the composition and condition of the absorbent oil being circulated. From experience in a large number of operating plants the writer has developed the following table of material transfer coefficients for *n*-butane corresponding to the ' $K_a aV$ ' factor of W K Lewis [7, 1927]

Type and condition of absorbent oil	Material transfer coefficient std cu ft <i>n</i> -butane per 24 hr per lb Δp per sq ft plate area
Poor oil, high mol wt (240), dirty, stripped to 0.5% pentane	450
Average Mid-Continent mineral seal oil, well stripped, clean (about 200 mol wt)	750-1,000
Special Mid-Continent low mol wt (180), narrow boiling range (400-500° F), well stripped, clean	1,000-1,300
Special California low mol wt (170), narrow boiling range (400-500° F), well stripped, clean	1,300-1,800

Based on observations of 16 plate bubble-tower absorbers under normal loads and operating in 30-40 lb gauge pressure range.

These figures indicate the importance of having advance information as to the specifications of available absorbent oils before selecting absorber tower size when designing a vapour-recovery plant. Despite the apparent advantage to be gained by the use of special oils it is the common practice of operators to be satisfied with the cheapest, most readily available oil in the range from kerosene to heavy gas oil. Also, some oils deteriorate in the system more rapidly than others, and it is usually false economy to circulate a poor grade of absorbent oil. The writing of an intelligent specification for absorbent oil is no easy matter. Too many limitations multiply the cost inordinately, too few limitations lead to poor quality. While molecular weight is one of the most important properties it is im-

herently linked to chemical composition and boiling range and is not subject to direct control by the refiner. Narrow boiling range is desirable also, but may be over-emphasized in the specifications of fresh oil, since most absorption plants have sufficient distilling and rectifying capacity to eliminate the lower-boiling fractions from the oil. It is more important to select an oil with the end-point well controlled, and with most of the oil distilling at a temperature higher than 400° F at atmospheric pressure. In general, it is well to avoid 'cracked' oils as being less stable than straight-run oils, although this is not always the case. The writer has found that a distillate that can be readily refined to a domestic kerosene specification will usually give satisfactory results in a modern absorption plant. Desirable properties of absorbent oils may be summarized as follows:

Molecular weight—As low as possible, compatible with boiling range

Distillation range—400–500° F. However, it is usually necessary to modify the range considerably. (Init. b p may be as low as 250° F, but not over 25% should distil below 380° F. End-point may be 550–600° F, but not more than 5% should distil above 500° F.)

Specific gravity—As high as possible, compatible with boiling range

Other properties—Resistance to cracking and emulsification, neutral chemical reaction, low sulphur content, light colour

Having selected an absorbent oil, the absorption problem is reduced to the determination of tower capacity and oil circulation necessary to treat a specified volume of gas of known average composition.

Tower capacity includes three distinct items: (1) gas-carrying capacity without oil entrainment, (2) oil-carrying capacity under gas load, and (3) material transfer capacity with respect to a key constituent of the gas and a specified degree of extraction of that constituent. The first two items are limited by velocity of flow and are not subject to much variation in operation, since the characteristics of tower design are fixed.

The selection of bubble-towers for capacity is assisted by use of an entrainment formula. The formula indicates the superficial velocity at which liquid carry-over may be expected to take place from a plate to the next plate above. The matter is complicated by bubble-cap design, liquid height on plates, liquid overflow restriction, liquid down-pipe capacity, foaming characteristics of the liquid, vertical distance between plates, pressure drop per plate, quantity proportions between liquid and vapour, and operating irregularities in flow. For several years the writer has used a curve based on the following modified Hausbrand [3, 1929] formula for the calculation of the superficial velocity in bubble-towers

$$V = 3.6 \sqrt{\frac{S \times T}{M \times p}} \quad (1)$$

in which V is the superficial velocity in ft per sec above which entrainment begins, S is the sp gr of the liquid at T° F Abs., M is the molecular weight of the vapour, and p is the absolute pressure of the system in lb per sq in. Souders and Brown's [6, 1934] entrainment formula may be reduced to a very similar expression and gives values about 10% lower than the Hausbrand formula. However, we have found by experience that it is unsafe to use these calculated values direct on account of the several complicating conditions listed above, and have established a table of

correction factors based on the pressure of the operation for convenience and because pressure reflects the resultant effect of these conditions indirectly. Thus we have found that the inherent characteristics of the processes using bubble-towers establish certain fairly definite proportions between liquid and vapour quantities depending upon the pressure of the operation, and for a given design of bubble-tower the operating pressure is a good criterion for the prediction of safe vapour velocity. For bubble-towers of 18-in. plate spacing, 4-in. liquid height on plates, a minimum of liquid overflow restriction, and relatively high liquid down-pipe capacity, the experience factors for modifying the calculated superficial velocity as indicated by the Hausbrand formula are as follows:

Pressure range, lb per sq in gauge	Maximum vapour velocity for good practice (multiply V by)
0–25	0.39
25–50	0.56
50–100	0.68
100–400	0.78

It will be seen that the permissible gas velocity increases with specific gravity of the liquid and decreases with specific gravity (or mol wt) of the gas. In other words, the greater the difference in densities of the gas and the liquid, the greater the gas-carrying capacity of an absorber. While this factor may not seem of much importance at first glance, the writer has observed instances in which it has made the difference between success and failure of an installation. In one case the absorption plant was treating natural gas being transmitted at high pressure by pipeline. The volume of gas to be treated varied largely from summer to winter and was also subject to sudden increases as the gas-distributing company was forced to meet daily peak-consumer demands. Much entrainment difficulty was encountered until a special absorbent oil was used. In another instance it was desired to use a wide boiling-range distillate containing about 50% gasoline as an absorbent, but it was found that sudden gas-volume increases would result in an almost complete emptying of the trays of the tower, the liquid being converted into a mist so fog-like in its nature that it would carry right through the mist extractors in the gas outlet. Gas-carrying capacity is also linked to oil-carrying capacity of a bubble-plate absorber. In operation the liquid is violently agitated by the gas bubbling through it on the trays, the temporary foam produced being skimmed off the top by overflow weirs, passing down sealed down-pipes to the trays below. The time required for the foam to break is finite, and the height to which liquid and foam builds up in the down-pipe itself statically balances the gas-pressure differential, or pressure drop, across the bubble tray. The length of the down-pipe from overflow weir to seal is quite an important factor in design in so far as tower capacity is concerned. Towers with short down-pipes may lose their liquid seals due to the increased pressure drop during a gas surge overcoming the weight of liquid and foam in the down-pipes. As a result the gas would pass up the oil down-pipes and the oil would flow through the gas-passages of the bubble caps, both oil and gas taking the course of least resistance. To return the tower to normal operation it would be necessary to proceed as when starting up a tower that has been out of service—circulate oil alone for some time at a high rate, then gradually introduce the gas.

The item of material transfer capacity of an absorber is

complicated by several factors which are best illustrated by an example. Let us assume that we are interested in selecting an absorber for the treating of 3,000,000 standard cu ft (1 c measured at 60° F and 30 in Hg pressure) of gas at 30 lb ga pressure. The average composition of the gas is determined by analysis, and the absorbent oil temperature for the problem may be assumed at a 5° F. approach to normal summer cooling-water temperature of, say, 80° F. Let us suppose that the desired performance is the extraction of 95% of the *n*-butane contained in the wet gas, together with as much as possible of all constituents heavier than butane. From an economical viewpoint the size of the absorber tower and the quantity of oil which may be circulated are distinctly limited, so it is first necessary to make an approximate check of the practicability of the specified degree of extraction and assumptions. The rich oil composition may be approximated by calculating the amount of each constituent absorbed if all constituents heavier than *n*-butane are 100% absorbed, *n*-butane 95%, and lighter constituents absorbed to saturation in the rich oil at an assumed rich-oil temperature of 15° F higher than the lean-oil temperature.

Preliminary absorption calculation

Gas volume = 3,000,000 cu ft per 24 hr
Pressure (*P*) = 30 lb ga = 44.7 lb abs

Constituent	Mol %	Mol wt	Mols	Partial mol wt	<i>v p</i> at 100° F rich-oil temp
Methane	47.14	16	3,733	7.5	2,970 from schu-
Ethane	21.02	30	1,666	6.3	650 bulby data
Propane	17.40	44	1,378	7.7	185
<i>n</i> -Butane	9.75	58	771	5.7	47.5
Pentane+	4.69	80	372	3.6	
	100.00		7,920	31.0	

Lean-oil temp = 85° F, rich-oil temp = 100° F

Constituent	Saturation in rich oil assumed	Mol % × satn	% Mol gas absorbed	Mols absorbed	Rich oil, mol %
Methane	1.00	0.0159	72*	0.71	
Ethane	1.00	0.0324	144*	1.45	
Propane	1.00	0.0941	407*	4.20	
<i>n</i> -Butane	0.95	0.1640	95.0	7.15	
Pentane+	1.00	0.1640	372	3.73	
Lean oil			(8,230)	82.56	
			(see below)		
		0.3064	9,947	100.00	

* Determined by direct proportion

$$\text{Mols absorbed, } 732 = \left(\frac{\text{mol \%} \times \text{satn}}{v p} \right) / 0.1640$$

$$\text{Mols lean oil} = \frac{(100 - 0.3064P) \times 732}{P \times 0.1640} - 372 = 8,220$$

Lean-oil characteristics: 6.8 lb per gal, 180 mol wt, 26.5 gal per mol *n*-Butane transfer coefficient (assumed average) = 1,000 sid cu ft per 24 hr per sq ft plate area per lb Δp

Indicated lean-oil circulation

$$26.5 \times 8,220 / 3,000 = 72.6 \text{ gal per 1,000 sid cu ft}$$

Check on practicability of desired extraction and assumptions

Driving force bottom of absorber (d_p)

$$p p \text{ } n\text{-butane in wet gas} = 0.0975 \times 44.7 = 4.35 \text{ lb}$$

$$p v p \text{ } n\text{-butane in rich oil} = 0.8 (\text{saturation}) \times 4.35 = 3.49 \text{ lb}$$

$$d_p = 4.35 - 3.49 = 0.86 \text{ lb}$$

Driving force top of absorber (d_p)

$$p p \text{ } n\text{-butane in dry gas} = 0.006 \times 44.7 = 0.27 \text{ lb}$$

$$p v p \text{ } n\text{-butane in lean oil} = 0.00 \text{ lb}$$

$$d_p = 0.27 \text{ lb}$$

$$\Delta p = (d_p - d_p) / \ln \frac{d_p}{d_p} = 0.51 \text{ lb}$$

Plate surface required with " K_{Ga} " of 1,000.

$$\frac{732 \text{ mols} \times 379 \text{ cu ft per mol}}{1,000 \times 0.31} = 545 \text{ sq ft total plate area}$$

Permissible gas velocity without entrainment

$$\text{By Hausbrand's formula, } V = 3.6 \sqrt{\frac{S \times T}{M \times P}}$$

$$\text{Experience factor for pressure range} = 0.56$$

$$S = 0.80 \text{ at } 90^\circ \text{ F } T = 550^\circ \text{ F Abs}$$

$$M = 31 \text{ average mol wt } P = 44.7 \text{ lb abs}$$

$$V = 0.56 \times 3.6 \sqrt{\frac{0.80 \times 550}{31 \times 44.7}} = 1.14 \text{ ft per sec}$$

Indicated proper tower cross-sectional area

$$A = \frac{3,000,000 \times 550 \times 14.7}{86,400 \times 1.14 \times 520 \times 44.7} = 10.6 \text{ sq ft}$$

$$D = \sqrt{\left(\frac{4 \times 10.6}{\pi \times 1416} \right)} = 3.68 \text{ ft}$$

Commercial bubble-towers are usually constructed with their diameter in integral numbers of feet. Therefore we would be inclined to select a tower 4 ft in diameter. Checking this diameter against the indicated required plate area of 545 sq ft we find

$$\text{Required no of 4-ft dia plates} = \frac{545}{12.57} = 43, \text{ which is}$$

in the order of twice the size tower as is considered good commercial practice.

Checking back to see how our assumptions worked out we find

(1) Temperature rise of oil

Constituent	Rich oil, mol %	Latent ht at 90° F B Th U per mol	B Th U absorbed
Methane	72	neg	
Ethane	144	neg	
Propane	407	6,300	2,560,040
<i>n</i> -Butane	732	8,800	6,450,000
Pentane+	372	12,000	4,470,000
Lean oil	8,220		
	9,947		13,480,000

$$\text{Total mols rich oil} = 9,947$$

$$\text{Sp ht of rich oil} = 90 \text{ B Th U per mol}$$

$$\text{Temp rise calc} = \frac{13,480,000}{9,947 \times 90} = 15.1^\circ \text{ F}$$

$$\text{Assumed temp rise} = 15.0^\circ \text{ F}$$

(2) Saturation of rich oil with respect to *n*-butane

Driving force at bottom of tower = 0.86 lb. This is large as compared to driving force at top of tower, which indicates that our assumption is conservative. Assuming more than 80% saturation would not materially lower the oil-circulation rate, since increased temperature rise would partly offset the advantage, and the size of tower would be rapidly increased as the Δp decreased. Assuming less than 80% saturation would increase the oil-circulation rate which is already higher than normal good practice dictates, the criterion being the proportion between the mols of desired constituents absorbed and the mols of undesired constituents absorbed, which in this case is 1,104 to 623. This high a proportion of normally gaseous constituents would offer difficulties in the condensing system.

(3) Degree of extraction of *n*-butane.

Since the indicated tower size is abnormally large, and the required oil circulation is as high as economically practical, and since it is best to be conservative as regards

the quality of the absorbent oil (the value for the *n*-butane transfer coefficient of 1,000 is the upper limit for average oil, higher values being usually obtainable only with special oils), our only other means of increasing the Δp in the temperature and pressure range of the problem is to increase the driving force at the top of the tower, which means leaving more *n*-butane in the dry gas

Consideration of the results of the preliminary calculation leads to the following conclusions

- (1) Either the *n*-butane transfer coefficient or the mean driving force (Δp) must be modified in order to bring the tower selection to a reasonable size
- (2) Oil circulation as indicated by the preliminary calculation is not as far out of commercial limits as tower size, therefore some modification of driving force at the bottom of the tower would be advantageous so that the increase in Δp will not be entirely due to loss of *n*-butane in the dry gas
- (3) The assumed temperature rise of the oil having been checked closely by the calculation, it may be expected that a small percentage modification in quantity absorbed and lean-oil circulation would not result in a marked change in oil-temperature rise
- (4) Believing that our original assumption of *n*-butane transfer coefficient is reasonable, let us decide to keep the same value and change Δp . Since, as we have already intimated, the calculated tower size is about twice as large as normal with $\Delta p = 0.51$, we need to assume a value of $\Delta p = 1.0$ to bring tower size to a reasonable selection. A close approach to equilibrium at either end of an absorber is uneconomic, since the approach is asymptotic in its nature, and the most efficient range of operation is that in which the driving force is the same throughout the tower. Therefore, knowing what value to take for Δp , we may adjust our assumptions of percentage extraction and saturation of the oil with respect to the key constituent (*n*-butane) so as to give a constant driving force.

Final absorption calculations

Gas volume = 3 000,000 std cu ft per 24 hr
Pressure (*P*) = 30 lb ga = 44.7 lb abs

Analysis of gas	Mol %	Mol wt	Mols	Partial mol wt	<i>v</i> p at 100° F rich-out temp	Saturation rich oil	Mol % × <i>x</i> abs <i>v</i> p
Methane	47.14	16	3,733	7.5	2,970 from solution data	1.00	0.0159
Ethane	21.02	30	1,666	6.3	650	1.00	0.0324
Propane	17.40	44	1,378	7.7	185	1.00	0.0941
<i>n</i> -Butane	9.75	58	771	5.7	47.5	0.77	0.1579
Pentane + Lean oil	4.69	80	372	3.8			
Total	100.00		7,920	31.0			0.3003

Constituent	% inlet absorbed	Mols absorbed	Rich oil mol %	Mols in dry gas	Mol % dry gas
Methane		64*	0.71	1,669	57.8
Ethane		130*	1.45	1,536	24.2
Propane		376*	4.20	1,002	15.8
<i>n</i> -Butane	82.0	632	7.06	139	2.2
Pentane + Lean oil	100.0	372 (7,378) (see below)	4.15		
Total		8,952	100.00	6,346	100.0

* Determined by direct proportion as before

Mols lean oil = $\frac{(100 - 0.3003P) \times 632}{P \times 0.1579} - 372 = 7,750 - 372 = 7,378$

Lean-oil characteristics 6.8 lb per gal, 180 mol wt. 26.5 gal per mol

n-Butane transfer coefficient (assumed average) = 1,000 std cu ft per 24 hr per sq ft. plate area per lb Δp

Indicated lean-oil circulation

$26.5 \times 7,378/3,000 = 65.2$ gal per 1,000 std cu ft

Driving force at bottom of absorber (Δp_b)

p p *n*-butane in wet gas = $0.0975 \times 44.7 = 4.35$ lb

P p *n*-butane in rich oil = $0.77 \times 44.7 = 3.35$ lb

$\Delta p_b = 4.35 - 3.35 = 1.0$ lb

Driving force at top of absorber (Δp_t)

p p *n*-butane in dry gas = $0.022 \times 44.7 = 0.985$ lb

P p *n*-butane in lean oil = 0.0 lb

$\Delta p_t = 4.35 - 0 = 4.35$ lb

$$\Delta p = (\Delta p_t - \Delta p_b) / \ln \frac{\Delta p_t}{\Delta p_b} = \frac{0.015}{0.0151} = 0.993 \text{ lb}$$

Quantity *n*-butane absorbed = 632 mols $\times 379$ std cu ft per mol = 239,500 std cu ft per 24 hr

Plate area required = $\frac{239,500}{1,000 \times 0.993} = 240$ sq ft total

No. of 4-ft dia plates = $\frac{240}{12.57} \approx 19$

Temperature rise of oil

Constituent	Rich oil, mols per mol	Lt ht B ThU per mol	B ThU absorbed
Methane	64	neg	
Ethane	130	neg	
Propane	376	6,300	2,370,000
<i>n</i> -Butane	632	8,800	5,560,000
Pentane + Lean oil	372	12,000	4,470,000
Total	8,952		12,400,000

Total mols rich oil = 8,952

Sp ht of rich oil = 90 B ThU per mol

Total heat = 12,400,000

Temp rise calc = $\frac{12,400,000}{8,952 \times 90} = 15.4^\circ \text{F}$

Assumed temp rise = 15.0°F

It should be noted that the above calculations are influenced by experience factors in several instances. For example, the engineer is required to select data which are compatible, and the only safe guide in the selection is actual

experience. The values of vapour pressure to be used for the normally gaseous constituents, the assumed saturation or approach to equilibrium at the bottom of the absorber with respect to individual constituents, the quantity of heat which accompanies the absorption of material, and the average specific heat of the rich oil are all selected with due regard to actual observations under similar conditions. Also, there are the factors of economics and good practice which are largely matters of judgement and experience.

Frequently it is desired to get an approximate value for the indicated proper oil-circulation rate for a certain degree of extraction of a key constituent from a gas. The method

outlined by Kremser [4, 1930] is extremely useful for this purpose. It is largely based on California practice, particularly with regard to the recovery of gasoline from natural gas. Kremser observed that natural gases possess certain type characteristics and that their actual composition could be neglected in most cases, and the oil rate could be approximated from a consideration of existing physical conditions and an assumption of a desired percentage extraction of a key constituent of the gas (Note: The conception of 'type' characteristics of gases has been discussed in the foregoing pages. See second paragraph under the general heading 'Absorption', p 1484.) The assumption of percentage extraction, of course, predicated a knowledge

additional plates becomes insignificant. A discussion of plate efficiency of commercial bubble-towers can become quite involved and depends largely upon the definitions. However, as Kremser points out, the factor of plate efficiency of absorbers loses much of its significance above 12 theoretical plates. Consequently, he 'standardizes' on a 16-plate commercial tower with an assumed plate efficiency of 75% of the theoretical. His judgement in this matter is strongly supported by the fact that the more modern natural gasoline plants have absorbers of 16 plates. However, the trend in refinery vapour-recovery plants is towards a greater number of plates in the absorbers. From an economic standpoint, the refiner attempts to

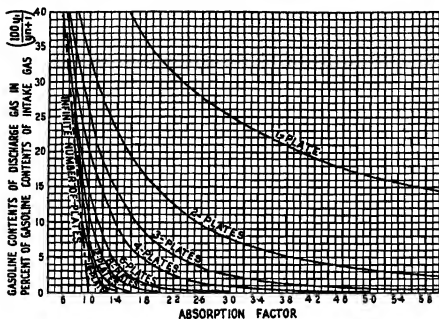

Fig 1

of the general composition of the gas, and particularly the order of magnitude of the proportion of the key constituent present, although the actual calculation does not involve composition. The formula derived by Kremser defines the absorption factor as follows

$$A = \frac{3156DpG}{MP} \quad (2)$$

where D = specific gravity of absorbent oil,
 p = absorber pressure lb per sq in abs,
 G = lean-oil rate, gallons per 1,000 std cu ft,
 M = molecular weight of absorbent oil,
 P = vapour pressure of key constituent at rich-oil outlet temp lb per sq in abs

By transposition we get the formula for lean-oil circulation rate

$$G = \frac{AMP}{3156Dp} \quad (3)$$

obtaining values for 'A' from Fig 1

Inspection of the above diagram reveals two important facts with regard to the economics of the absorption process. First, too few plates will greatly increase the oil-circulation rate when the desired degree of extraction of a constituent is above 90%. Second, use of more than 16 theoretical plates is seldom justified, since the effect of the

fullest extent. During certain periods of the year many refiners need to supplement their production of volatile fractions by the purchase of natural gasoline. For this reason it is customary for them to insist upon their vapour-recovery plants having capacity and design features which make it possible to hold the ultimate maximum quantity of butanes compatible with reasonable investment and operating costs. Also, gas quantities in refineries are subject to wide fluctuations, and for this reason alone the advantage of the 'fly-wheel' effect of absorbers of ample capacity warrants the use of more plates than would be justified in a plant handling natural gas at fairly constant rates of flow. It is not at all unusual to find absorbers containing as many as 30 plates in plants treating refinery gases.

The absorption process being a continuous one in practice, it is quite obvious that the cumulative effect of small inefficiencies can reach alarming proportions. In the absorption calculations above, the driving force at the top of the tower was based on the assumption that the partial vapour pressure of *n*-butane was 0.00 lb in the absorbent oil. The truth of the assumption is dependent upon the efficient operation of the distillation units of the plant. Likewise, the complete recovery of the heavier gasoline constituents is impossible with an absorbent oil containing appreciable amounts of these fractions. Therefore, no matter how carefully the absorbers are designed, process shortcomings may upset all calculations.

Distillation and Stripping

The distillation system of an absorption plant has the primary function of putting the absorbent oil into condition for re-use in the absorbers. However, the simple removal of absorbed constituents is so circumscribed by economic considerations and operating limitations that the fundamental purpose of the unit is often obscured. This is particularly true of the more modern plants which are designed to take advantage of the lower molecular weight absorbent oils. Thus the distillation system is expected to (1) strip the absorbent oil of gasoline fractions;

(2) effect the removal of absorbed constituents without appreciable loss of oil, (3) effect a high recovery of absorbed constituents as liquid without resorting to compression of vent vapours, and (4) to accomplish these ends with the minimum of heat input and consumption of direct steam

Taken as whole, the distillation system of a recovery plant includes oil heat exchangers, preheaters, and reheaters, and gasoline condensers, coolers, and accumulators, as well as the stripping and rectifying towers themselves. In this discussion, however, we will confine ourselves to the physical limitations directly affecting efficiency of operation both with respect to the removal of absorbed material and the recovery of these products in the liquid state, therefore centring our attention on the equilibria existing in the distillation columns and condensers in particular.

Let us first consider the mechanism of stripping a volatile material from an essentially non-volatile medium such as is the case with enriched absorbent oil. In order that stripping be accomplished it is obvious that the partial vapour pressure in the liquid of the heaviest constituent desired in the vapour must exceed the partial pressure of that constituent in the vapour in contact with the liquid. Therefore, for essentially complete stripping of hexane, for example, the vapours in contact with the stripped oil at the base of the stripping column must be diluted with vapours or gases other than hexane to such an extent that the partial pressure of hexane is negligible. This reduction of the partial pressure of the key constituent in the stripping operation is accomplished in practice by two means—the vaporization of substantial proportions of constituents heavier than the key constituent, and the introduction of direct steam at the base of the stripping column. The mathematical relationship for complete stripping of a given constituent from absorbent oil [8, 1927] is

$$\pi/P = G/L, \quad (4)$$

in which π is the pressure of the operation in lb per sq in abs, P is the vapour pressure of the constituent being stripped at the outlet temperature of the lean oil, and G is the number of mols of steam or other vapour in contact with L mols of lean oil. From this it is seen that the quantity of stripping steam or vapour varies in direct proportion to the absolute pressure of the operation and in inverse proportion to the vapour pressure of the key constituent, and, since vapour pressure varies directly with temperature, the quantity of steam required for the stripping will vary inversely with the temperature of the lean oil at the outlet. It would appear from these relationships that low pressures and high temperatures are the ideals to be sought in stripping-still operations, but it is also desired that the absorbed material which is stripped from the oil shall be recovered as a liquid product. This factor tends to force the distillation pressure higher and higher with increasing percentage extraction in the absorbers, since the proportion of absorbed high vapour-pressure constituents is correspondingly increased. Also, the maximum temperature is frequently limited by the pressure of available steam and by the vaporization characteristics of the absorbent oil. Vaporization of a portion of the absorbent oil in the stripping column places another limitation upon the choice of oil. We have already stated that too light an oil makes for sensitive operation in the absorbers. It is likewise true that an oil with an excessive amount of low boiling fractions will place

an unwarranted burden on the distillation system. However, a certain amount of vaporization of the absorbent oil in the stripping column is beneficial and results in a reduction in the quantity of direct steam for the stripping. Comparing the two methods from an economic standpoint, suppose we are producing this stripping vapour at 350° F by condensing steam at 175 lb ga pressure in a tubular oil heater. The quantity of heat to produce a mol of vapour of 140 mol wt would be

$$140 \times 115 \text{ (ave latent heat)} = 16,100 \text{ B Th U,}$$

and since steam at 175 lb ga pressure has a latent heat value of 847 B Th U per lb, it would require

$$16,100/847 \sim 19.0 \text{ lb of steam}$$

A mol of steam weighs 18 lb, so mol for mol it would cost 5.5% more to strip with 140 mol wt oil vapours than with direct steam, other factors being equal. This small advantage in favour of steam for stripping may easily be offset by the value of the condensed steam for boiler feed, the condensate being lost when direct steam is used.

It is very difficult to establish the optimum combination of conditions with regard to the vaporization characteristics of the absorbent oil. As a matter of experience, the writer has set the figure of 10% of the oil circulation as the maximum allowable vaporization of the oil in the stripper. By designing the heating and condensing units with capacity for this load in addition to the normal heat load, it will be found in operation that the plant will tend to correct the boiling range of the oil automatically unless the oil is so light that a major portion is flashed to vapour under the conditions of the operation. Too light an oil produces an excessive quantity of internal reflux with a resultant cooling of the column and lowering of the lean-oil outlet temperature, but as circulation is continued it will be found that the initial boiling-point of the oil will gradually rise to some maximum figure, which will be more or less characteristic for the plant in question. The excess light material originally in the oil will be lost in part to residue gas in the absorbers, the balance being recovered in the gasoline distilled from the enriched oil. At the same time the lean-oil outlet temperature will gradually rise as the load due to excessive internal reflux is decreased. The normal reflux load in the columns is established by the magnitude of cooling necessary to control the final distillation temperature of the gasoline produced. The desired 'end-point' of the gasoline requires careful consideration in the plant design. It is wasteful to demand 250° F end-point on a gasoline which is to be blended with material of 350–450° F end-point, for not only must heat be supplied to the columns for heating and vaporizing the additional reflux material, but also an equivalent amount of heat must be removed in condensing and cooling this material.

In designing a plant, the decision regarding the pressure for operation of the still is influenced by several important factors, but the first logical step in reaching this decision is the consideration of the efficiency of condensation of the absorbed material. This may be well illustrated by continuing the example started under 'Absorption'. Assuming that we will be able to condense and cool the gasoline to a final equilibrium temperature of 85° F (the temperature to which we cooled the lean absorbent oil), let us make a series of equilibrium calculations covering a range of pressures. A typical calculation follows

vapour has no tendency to set up a 'recycle' in the system as would be the case should the uncondensed vapours from the still be returned to the absorbers with the wet gas (which is a common method of attempting to increase the butane recovery)

The example cited above should serve to emphasize some of the difficulties which confront the engineer in designing the distillation system when high efficiency at low operating cost is imperative. The effort to avoid some of these difficulties led the writer and associates to develop the two-still system which has proved quite successful in refinery vapour-recovery operations. In this system the rich oil from the absorbers is first introduced into a distilling and rectifying column operated at a pressure sufficiently high to give essentially complete condensation of the valuable absorbed material (say, 100 lb.) No attempt is made to strip the absorbent oil in this still. It is only necessary to distil the lighter constituents that would prevent the condensation of the heavier constituents at a reasonably low pressure. The semi-rich oil is then introduced into a second distilling and rectifying column operated at a much lower pressure (say, 8 to 15 lb. ga.) In this way the absorbent oil may be economically stripped of all absorbed constituents and the products condensed almost completely. It is advantageous in this operation to pump the heavier gasoline obtained from the low-pressure still into the high-pressure still condensing system so that the molar effect of the heavier constituents on the condensation of the lighter ones may be utilized.

The procedure for selecting an absorption-plant stripping and rectifying column, in so far as size and capacity are concerned, is quite similar to that for absorber selection. Temperature effects must be watched carefully, particularly with respect to liquid-carrying capacity of the down-pipes. It must be remembered that the maximum liquid rate to be handled by the column is made up of (1) the total lean-oil rate to the absorbers; (2) the increased volume of the oil due to absorbed constituents (in the example cited this increase amounts to nearly 10%); (3) the increased volume of the rich oil due to thermal expansion on heating (in the example the rich oil was heated to 370° F and the material has a coefficient of expansion of about 0.0006, which would indicate an increase of approximately 18.6% in liquid volume); and (4) the internal reflux returning from the rectifying section to the stripping section which should be estimated at about 10% of the lean oil. Totalling these items

Lean oil, 60° F basis	195,500 gal
Absorbed material (60° F basis)—1,574 mols at 12.3 gal per mol	19,350 "
Internal reflux (60° F basis)	19,350 "
Expansion rich oil and reflux 60 to 370° F	43,600 "
Total	278,000 "

which is an increase of nearly 30% in volume of oil to be carried by the down-pipes of the stripping column.

Since it has become general practice in the industry to consider the recovery-plant still as a fractionating column, consisting of a stripping section surmounted by a rectifying section, adding heat at the base and controlling heat removal at the top by means of pumped-back reflux liquid, we will confine our discussion to that type of equipment. Theoretical consideration is, however, quite different from that of a fractionating column, the fractionation being more general in its nature, the division-point being between the essentially non-volatile absorbent oil and the volatile absorbed material instead of between adjacent members of a series of hydrocarbons. Likewise the reflux quantity is not determined by consideration of the molar concentra-

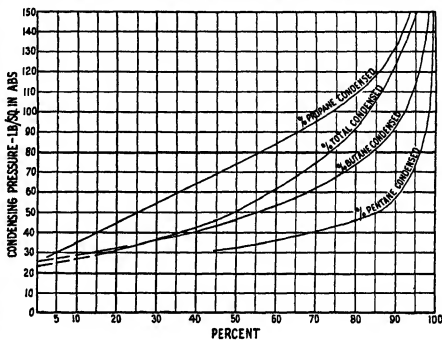

FIG. 2

tions of individual constituents from plate to plate as is necessary in a true fractionating problem, but rather by the temperature effect of evaporating a certain quantity of the volatile liquid material in the rectifying section. Thus, the control is usually to a fixed temperature at the top of the column, this temperature bearing some relationship to the desired end-point of the overhead condensate as indicated by the conventional Engler distillation test, the proper running temperature being determined in practice by a series of trial tests.

The reflux quantity is best obtained by a heat balance on the rectifying section. Although this requires certain assumptions, such as quantity and latent heat of the internal reflux, temperature to which the overhead vapours must be cooled for end-point control on the product, average latent and specific heats of the reflux material, and the like, reasonable errors in these assumptions are not particularly serious. It is best to be conservative in making such assumptions where the result affects size of equipment, since it is advantageous to have excess tower, condensing, and pumping capacity. For example, the overhead vapour temperature will be lower than the end-point of the product, how much lower depending on the pressure, the proportion of steam, and the proportion of low-boiling constituents. The required overhead temperature is *increased*

by raising the column pressure, and decreased by increasing the proportion of steam and low-boiling constituents, and there is no simple rule for predicting it accurately. However, in practice it will be found that the overhead temperature will almost always fall in the range of from 100 to 180° F lower than the end-point of the product. That is, if the interpretation of the effect of conditions is entirely wrong and the assumption is made that the overhead temperature will be 180° F lower than the end-point when it should be only 100° lower, we cannot be in error more than 80° F, which would not increase the size of equipment unreasonably, and would not affect economy of actual operation except in the item of fixed charges (interest, depreciation, &c.)

After arriving at a required reflux quantity, its approximate composition should be calculated through a series of equilibrium calculations similar to that shown on p 1490, taking into consideration the effect of the increased number of mols of heavier constituents present in the condensers due to the recirculation of the reflux material. The equilibrium calculations made for the purpose of establishing operating pressure furnish an approximate uncondensed or residue vapour composition, and from this it is possible to calculate the approximate reflux composition as follows

Constituent	Mol % residue* (from equil calc)	P_a at 82° F	Mol % P_a	Approx reflux composition mol %/ P_a = 2.(mol %/ P_a)
Methane	17.15	2,700	0.00635	0.57
Ethane	24.43	550	0.04215	3.63
Propane	38.30	153	0.23050	20.77
n-Butane	20.42	40.6	0.50300	45.30
Pentane+	2.62	8.0	0.32705	29.50
	99.92		1.10990	99.97

* Values taken from 90 lb per sq in abs equilibrium calc (p 1490)

If a more accurate composition is required it is necessary to make up a new composite vapour entering the condensing system, including the calculated quantity of reflux of the approximate composition as determined above, and to carry out a new set of equilibrium calculations as before. The approximate reflux composition which can then be obtained from the second set of equilibrium calculations will be more nearly the actual composition. This process may be repeated as many times as desired, but it will be found that no appreciable change in the composition of either the uncondensed vapours or the reflux liquid will result after the third set of calculations.

It is now possible to obtain the maximum volume of vapours to be handled in the column. Although this volume varies throughout the column, for purposes of design and selection of proper cross-sectional area it is necessary to know the maximum possible volume passing any point in the column. This maximum volume will be the total of the following items

- 1 Volume of absorbed constituents distilled
- 2 Volume of stripping steam
- 3 Volume of vaporized portion of absorbent oil
- 4 Volume of vaporized reflux liquid

Actually, the maximum volume of each of the above items will not exist at a given point in the column simultaneously, but the first three will normally exist at the feed tray, and under surging conditions it is possible to obtain the equivalent of all four at this point. Obviously, it is the actual volume under the temperature and pressure con-

ditions of the operation which must be considered. It should be pointed out that a stripping and rectifying column is inherently more subject to sudden fluctuations and surges than absorbers, and it is therefore important in still design to be conservative in the selection of tower size with regard to vapour velocity.

Fractionation and Stabilization

The process of fractionation is considerably more definite in its nature than either of the other two processes already discussed. As a consequence it has been the subject of a great deal of careful research both in the laboratory and in plant-scale installations. A very comprehensive treatment of the theory of fractional distillation is given by Gurwitsch [2, 1913] in which the effect of successive vaporizations and condensations (such as takes place from plate to plate in a column) is shown graphically. The application of the theoretical principles of fractionation in the petroleum industry has been quite rapid since the general adoption of fundamental analysis, although in the strictest interpretation true fractionation (sharp separation of constituents) is carried out commercially only in the range of the lower-boiling hydrocarbons (say n-octane and lower). However, in the broader sense, the influence of the growth of a common knowledge of the principles of fractionation can be seen in design and operation over the entire range of distillation.

Although the theory of fractionation is quite definite, it is applied readily to two-component systems only. In the commercial handling of petroleum hydrocarbons, two-component systems are obtainable only as a result of preliminary fractionations of complex mixtures and therefore are really of secondary importance. However, by making certain assumptions it is possible to apply the theory to complex mixtures, considering the fractionation as taking place between adjacent components of the mixture just as though they were the only two present, and modifying temperatures, pressures, and rates so that they are compatible with the actual composition. McCabe and Thiele [5, 1925] present a method of graphically solving the problem of fractionation with particular reference to the establishment of proper operating conditions, number of plates in the tower, reflux rates, and incidentally the practicability of the proposed separation. In a somewhat modified form this method has been used by the writer in the design of commercial fractionating towers with quite satisfactory results. The method can be best explained by illustrating its use in an example. For convenience let us continue with the case started under the heading of "Absorption", taking that portion of the absorbed material which was recovered in the distillation system at a pressure of 90 lb per sq in abs. The equilibrium calculation for this pressure gives the following result (p 1493).

Let us say that our problem is to design a fractionating column for separating the liquid condensate of the composition just calculated into an overhead cut containing essentially all the propane and lighter constituents, and a bottom product containing all the pentane+ and as much as practicable of the n-butane entering the column. It is desired to carry out this fractionation under such a pressure that the condensers may operate successfully with cooling water at 80° F. Experience teaches that the column overhead temperature cannot be lowered economically to a point closer to the cooling-water temperature than about 25° F, which guides our assumption of overhead temperature to the figure of 105° F. Also, we learn from experience

Constituent	P, at 83° F	Mol % A ₁	K = P ₁ /P ₀	V = 21% L = 79%			Mols			Mol % L
				L/K	L/K+V	Mol % V	V+L*	V	L	
Methane	2,700	4.06	30.0	2.64	23.64	17.15	64	56.5	7.5	0.6
Ethane	550	8.30	6.1	12.95	24.43	130	80.6	80.6	49.4	4.0
Propane	153	23.89	1.7	46.5	67.5	35.58	376	116.7	259.3	20.8
n-Butane	40.6	40.15	0.45	175.5	196.5	20.42	632	67.5	564.5	45.4
Pentane+	8.0	23.60	0.09	879.0	900.0	2.62	372	8.7	363.3	29.2
		100.00				100.00	1,574	330.0	1,244.0	100.0

* From 'mols absorbed' shown in final absorption calculation, p 1490

that the quantity of reflux to be returned to the column in this type of operation is in the order of magnitude of an equal number of mols to that entering the column as feed, which enables us to approximate the reflux composition and the corresponding operating pressure

Constituent	Mol % feed	Mols feed	Mols residue	Mols bottoms	Estim. reflux comp.	
					Mols	Mol %
Methane	0.6	7.5	7.5		2	0.16
Ethane	4.0	49.4	49.4		65	5.20
Propane	20.8	259.3	259.3		1,177	94.64
n-Butane	45.4	564.5		564.5		
Pentane+	29.2	363.3		363.3		
	100.0	1,244.0	316.2	927.8	1,244	100.00

v p propane at 105° F = 200 lb per sq in abs

Mol fract propane in reflux = 0.9464

Approx column pressure for condensation of propane at

105° F = 200/0.9464 = 211 lb per sq in abs

= 196 lb per sq in ga (approx)

Having established the approximate pressure of the condensing operation it is now possible to determine the probable base temperature for the column. This is done by trial, the problem being to find the temperature at which the sum of the partial vapour pressures of the bottoms constituents equals the pressure at the base of the column. First let us assume that the pressure drop through the column is in the order of 3 lb. This gives us a column-base pressure of 211+3 = 214 lb per sq in abs as a criterion for the trial calculation

Constituent	Bottoms comp Mols	Mol frac	First trial		Second trial		Third trial	
			v p at 225° F	p p p	v p at 250° F	p p p	v p at 240° F	p p p
n-Butane	564.5	0.6084	250	152	325	198	315	192
Pentane++	363.3	0.3916	40	16	57	22	53.5	21
	927.8	1.0000		168		220		213

* Assumed for trial † Average hexane.

In the application of the McCabe and Thiele method, the assumptions to be made are:

- 1 That in fractionating a mixture of several components, the equilibrium relationships of the two members between which the separation is to be made are the important ones. (In other words, consider the system as a two-component one in so far as the equilibrium calculations are concerned.)
- 2 That it is possible to establish equilibrium between the liquid and the vapour in contact with it.
- 3 That the equilibrium concentration of a component in the liquid and in the vapour at a contact-point is controlled by the ratio of vapour pressures of the two components at the existing temperature.
- 4 That the ratio of vapour pressures of the two components has a negligible variation over the tempera-

ture range of the operation, and that the ratio at the arithmetical average temperature is sufficiently accurate to be used as a constant in the equilibrium calculations

- 5 That commercial bubble-plates of a given design bear a fixed relationship to theoretical plates and that shortcomings in their ability to produce a near approach to equilibrium between liquid and vapour may be compensated for by adding additional commercial plates

The equilibrium line is obtained by plotting the calculated values of the mol fraction of the lighter component in the vapour corresponding to a series of assumed mol fractions of the same component in the liquid. The mathematical relationship is as follows

$$y = \frac{\alpha x}{1 + (\alpha - 1)x}$$

in which y is the mol fraction of the lighter component in the vapour, x is the mol fraction of the same component in the liquid in equilibrium with it, and α is a constant, being the numerical ratio between the vapour pressure of the lighter component at the average column temperature and the vapour pressure of the heavier component at the same temperature. In the case under consideration the top and bottom temperatures are 105° F and 246° F respectively, the arithmetical average being 175° F. The vapour pressure of propane and n-butane at 175° F are 443 lb per sq in abs and 145 lb per sq in abs

$$\alpha = \frac{443}{145} = 3.05$$

The establishing of a value for α makes it possible to proceed with the calculation of the values of y corresponding to a series of x values (assumed) required for the development of the equilibrium line of the McCabe and Thiele diagram

x	αx	($\alpha - 1$)x	1 + ($\alpha - 1$)x	y = $\frac{\alpha x}{1 + (\alpha - 1)x}$
0.05	0.153	0.103	1.103	0.138
0.10	0.305	0.205	1.205	0.253
0.20	0.610	0.410	1.410	0.433
0.30	0.915	0.615	1.615	0.567
0.40	1.220	0.820	1.820	0.670
0.50	1.525	1.025	2.025	0.753
0.60	1.830	1.230	2.230	0.821
0.70	2.135	1.435	2.435	0.877
0.80	2.440	1.640	2.640	0.924
0.90	2.745	1.845	2.845	0.965
0.95	2.898	1.948	2.948	0.983

Fig 3 shows the completed diagram

The 45° line represents zero fractionation, and the equilibrium line would coincide with it if the two components have identical vapour pressures, i.e. a vapour-pressure ratio of 1.0. It is apparent that the larger the vapour-pressure ratio the more marked will be the curvature of the equilibrium line, and inspection reveals that the

tendency for the vapour to become enriched in the lighter component is also more marked as the ratio increases

The construction of the McCabe and Thiele diagram is carried out as follows

Using ordinary coordinate paper, equal scales are laid off with x on the abscissa and y on the ordinate, the range of the scales being from 0 to 1.0 by tenths. In practice the scale should be large, say, at least 10 in long each way,

feed line must fall between points (A) and (B). The nearer (C) is to (A) the greater will be the quantity of reflux, and the nearer (C) is to (B) the greater will be the number of plates required. Since quantity of reflux entails a continuing cost it is more economical to use a maximum number of plates. For this reason the writer usually locates (C) about two-thirds of the distance up from (A) towards (B).

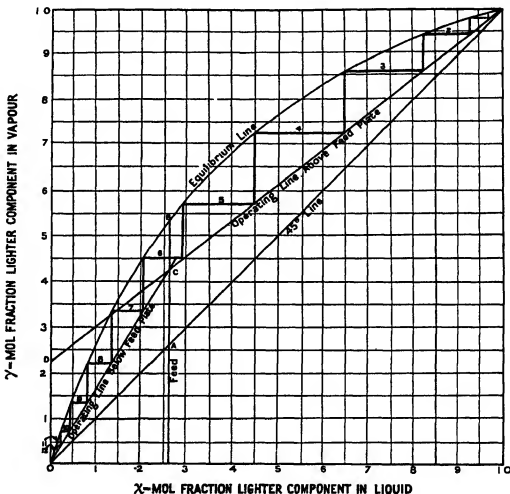

FIG 3

since the usefulness of the diagram is dependent upon accuracy of reading values at the extremes. Then the 45° line should be drawn in, intersecting both 0 and 1.0 lines. The feed composition is determined and the mol fraction of the lighter component in the feed (including propane, ethane, and methane in our example) is laid off on the x scale and a vertical feed line is drawn in, starting at that point. Values for x and y (from the values calculated in the preceding paragraph) are then plotted and a smooth curve drawn through the points, including also the points 0 to 1.0. The starting-points and direction of the operating lines are less definite, and their location on the diagram must be dictated by experience. The following general observations may aid the inexperienced in reaching a decision

- 1 It is easier to approach 0 mol. fraction of the lighter component in the liquid than to approach 0 mol fraction of the heavier component in the vapour.
2. The intersection (C) of the operating lines and the

- 3 The economical limit to which the heavier component can be reduced in the overhead vapour is determined largely by the ratio of vapour pressures of the two components (still considering multi-component mixtures in the light of two-component theory). The following table is based on experience in the range of the lower-boiling petroleum hydrocarbons:

y/p ratio at ave column temp	Economical limit for reduction of mol fract of heavier in overhead vapours
1.0	mol. fract. heavier in feed
1.5	0.10
1.8	0.07
2.0	0.06
2.5	0.04
3.0	0.02
3.5	0.01
higher	neg.

Proceeding with the construction of the diagram, (C) is located on the feed line approximately two-thirds of the distance up from (A) towards (B). The operating line above the feed plate is a straight line drawn through (C) and intersecting the 45° line at a point corresponding to the limit of reduction of the heavier component in the overhead vapour (in this case the v/p ratio is 3.05, which indicates a limiting value of about 0.02 mol fraction heavier, i.e. 0.98 mol fraction lighter, in the vapour). This line is extended to (D), the intersection with the y -axis. The value of y at (D) represents approximately the ratio of mols of overhead vapour fraction to total mols of overhead plus reflux. The operating line below the feed plate is a straight line drawn through (C) and intersecting the 45° line a little near 0 mol fraction lighter in the liquid than the other operating line approached 0 mol fraction heavier in the vapour (see 1 above). Starting at the intersection of the operating line above the feed plate with the 45° line, draw a continuous step-wise line alternately horizontally and vertically, crossing the space between the operating and equilibrium lines, continuing until a vertical line falls to the left of the intersection of the lower operating line with the 45° line. The number of steps, i.e. horizontal lines, indicates the number of theoretical or equilibrium plates required for the fractionation. It is customary to allow an efficiency of only 50 to 66% for commercial bubble plates. Should a factor of 2 be used (50% efficiency) and the actual number of commercial plates thus found to be greater than, say, 40, a new diagram should be drawn modifying the degree of fractionation at either top or bottom, depending upon the requirements.

The diagram presented indicates that the fractionation can be carried out with 12 equilibrium plates or 24 commercial plates, which is well within the limits of good practice. Likewise, the reflux ratio is within the practicable range. In the preceding paragraph the statement was made that the point of intersection of the operating line with the y -axis serves as an indication of the reflux ratio required for the fractionation. However, it is customary to refer to the reflux ratio as the ratio between the number of mols returned to the tower and the number of mols contained in the overhead fraction. This may be obtained approximately from the y intercept value through the following relationship:

$$\frac{\text{Mols reflux returned}}{\text{Mols overhead fraction}} = \frac{1}{y} - 1$$

In the diagram of the example $y = 0.225$, therefore the reflux ratio indicated is

$$\frac{1}{0.225} - 1 = 3.45$$

In the preliminary calculations for determining proper operating pressure the assumption was made that the number of mols of reflux would be of the same order of magnitude as the number of mols of feed. The reflux ratio just determined gives $3.45 \times 316.2 = 1,090.9$ mols of reflux, which is near to the number of mols of feed (1,244).

Before leaving the subject of the theoretical design of fractionating columns, mention should be made of an alternate method presented by Brown, Souders, and Nyland [1, 1932]. It is similar to that of McCabe and Thiele, but directly applicable to multiple component mixtures when combined with the absorption-factor method of Kremser [4, 1930], considering the fractionating and stripping sections separately in the light of absorption

theory. In this way the behaviour of each component can be charted and the probable composition at each equilibrium plate may be predicted. It is the opinion of the writer that since the simpler method of McCabe and Thiele gives such satisfactory results in the usual application, the requirements of the complex method are not justified, particularly in those cases in which feed composition and fractionation requirements are subject to radical changes. However, the value of having available a method for accurately calculating the behaviour of complex mixtures in special cases is inestimable.

The procedure to be followed in determining the size of the column is very similar to that already described. It should be pointed out that in commercial installations feed quantity and composition may both change radically from that existing at the time of the design calculations, and it is always wise to make a number of check calculations to find the effect on the efficiency of operation in the eventuality of doubling or halving the feed quantity, varying the proportion of overhead fraction, and varying the fractionation requirements (i.e. the degree of removal of lighter and limitation on loss of heavier component).

Both material and heat balances are aids in designing an efficient and flexible unit. By balancing input against output the capacities of the reboiler and condenser are determined, and the possible variations in quantity, composition, and fractionation requirements discussed in the preceding paragraph must be taken into account in regard to their effect on these important auxiliaries. Special emphasis should be laid on the part played by the reboiler and condenser on the overall efficiency and flexibility of the fractionating unit. A continuous and positive supply of reflux material must be available if the unit is to operate successfully, so condensing capacity should be provided to handle the maximum quantity of reflux which the operation may require. Likewise, the reboiler must have not only sufficient capacity to vaporize the overhead fraction and heat the bottoms fraction to the final outlet temperature, but also must supply heat for the vaporization of the reflux material introduced into the column. Thus it is obvious that the operating capacity of a fractionating unit may be limited by either the column itself or one or both of its auxiliary units, the reboiler and reflux condenser. There is another limitation which is more intangible but of even greater importance than the physical design capacities of the equipment, and that is the matter of temperature, pressure, and rate control.

In the process of fractionation a liquid is subjected to countercurrent contact with a vapour of somewhat higher temperature with a resulting interchange between the two, part of the liquid being converted into vapour and vice versa, resulting in a concentration of higher-boiling constituents in the liquid and a concentration of lower-boiling constituents in the vapour. Under ideal conditions the interchange will approach equilibrium, i.e. the partial pressure of each constituent in the vapour will approach the partial vapour pressure of the same constituent in the liquid in contact with it. In commercial practice it requires considerable time (from 1 to 5 hr depending on the capacity of the unit) for the successive interchanges in the contact zones to reach a state of balance in so far as the average composition of the material in the zone is concerned, and the compositions of the material in adjacent zones becomes compatible. When such a state of balance is brought about, what is known as 'smooth' operation is obtained, and the unit is operating at its maximum efficiency.

under existing conditions. Should the control be imperfect, periodic minor surges within the column take place and prevent the material in any contact zone from reaching the state of balance mentioned above. This results in the average composition of the material in adjacent contact zones being more nearly the same than approach to true equilibrium conditions would indicate, that is, the sharpness of the separation is adversely affected by the intermittent 'dumping' of material into zones filled with material of a composition incompatible with that of the added quantity. A great deal could be said on the subject of control, but the value of a detailed discussion is doubtful since there are so many possible combinations and types of instruments. However, a few general suggestions based on actual observation should be helpful in clarifying the conception of the fractionation process as applied to commercial operation. For simplicity the discussion will be limited to individual items where possible, although it should be borne in mind that these items really interlock and our observations are largely made on resultant effects.

Composition and Quantity of Feed Material. On account of the considerable length of time required for a commercial column to reach a state of balance (see preceding paragraph) any sudden change in the composition or quantity of the feed material should be avoided. The best safeguard against sudden changes in feed rate and composition is the use of a surge tank of ample capacity. In large units the cost of pressure tanks limits the provision of a supply of feed material for any extended period of time, such as 6 or 8 hr., as would be desirable. For example, one of the largest high-pressure (100 lb per sq in ga.) stabilizer feed surge tanks that has come within the observation of the writer has a total capacity of 37,000 gal. The tank is normally kept 50% filled, furnishing an available supply of about 18,000 gal. At the normal feed rate of 150 gal per minute this represents a 2-hour supply which seems rather small. In fact, it would be entirely inadequate for a small unit, but luckily large-scale operations possess certain inherent advantages, the magnitude of variations in composition and rate being normally much less marked, on a percentage basis, than in small-scale operations.

Temperature and Point of Introduction of Feed Material. The ideal temperature to which the feed material should be heated before introduction into a continuous fractionating column is the boiling-point of the material at the pressure of the operation. If the feed temperature is much different from this, a zone of readjustment is created in the column which may overlap a number of plates and in which very little effective fractionation takes place. The explanation is, that with the feed heated above its boiling-point a sudden flashing to vapour occurs at the feed plate and the large volume of hot vapours surge upwards, altering the equilibrium conditions over an indefinite number of plates, with the feed below its boiling temperature a similar altering of equilibrium conditions takes place, the excessive quantity of colder liquid flowing from plate to plate until the cooling effect is overcome by hot vapours from the reboiler. Such a condition is reflected in plate to plate temperature readings as a zone of nearly constant temperature indicating little or no fractionation. Prediction of proper feed temperature may be made by the trial method of calculating total vapour pressure from feed composition. This may be illustrated by using the composition of our general example

Constituent	Mol %	v.p. at 160° F	p v p	v.p. at 170° F	p v p	v.p. at 160° F	p v p
Methane	0.6	4,000	24	4,200	26	4,150	23
Ethane	4.0	1,000	43	1,100	46	1,125	45
Propane	20.8	375	78	420	87	400	83
n-Butane	45.4	115	52	132	60	124	56
Pentane +	29.2	15	5	17.5	5	16	5
$\Sigma p v p$			202		224		214

which indicates that a temperature of 166° F would be proper for a column pressure of 214 lb per sq in abs. The determination of the proper point in the column for the introduction of the feed is more indefinite. It would appear desirable that the feed should be introduced at the point where the composition gradient in the column will be effected least radically. In effect this is true, but it is practically impossible of accurate determination. The McCabe and Thiele diagram furnishes a means for the selection of the feed inlet point, but is rarely used for the purpose in practice. Commercial towers are usually supplied with three or more alternative feed inlet nozzles, the actual choice of the one to use being left to the judgement of the plant operator in the majority of cases. And, since the operator's judgement is based largely on actual experience, the result is probably as satisfactory as if it were based on purely theoretical considerations with a few more or less correct assumptions added. Thus an operator will introduce the feed at the middle inlet in the absence of specific reasons for not doing so. Then if operating results show that the chief difficulty centres in the removal of the lighter component from the bottoms, he will change the feed to the next higher inlet, increasing the proportion of stripping plates in operation. Likewise, if the difficulty is excessive loss of heavier component overhead, he will throw more plates into fractionating service by lowering the point of feed introduction.

Operating Pressure of the Column. The maintaining of a constant column pressure is essential for smooth operation. Although in actual practice most pressure fluctuations are merely the reflection of temperature surges, the column reaction from the sudden pressure change is probably more upsetting in its effect than the original temperature surge. This may be explained by the fact that a sudden increase in pressure will start excessive condensation of vapour throughout the column, with a resulting dumping of liquid from plate to plate, then as the downflow of unstripped liquid reaches the reboiler, a sudden evolution of vapours takes place which tends to cause the pressure to increase further. The resultant effect on the operation shows up as periodic cycling. There are conflicting opinions as to the best method of controlling column pressure, some engineers holding that the quantity of overhead vapours should be restricted to a more or less average rate by a slow-acting controller. The writer favours the theory that in operation the pressure effect is more nearly a result than a cause, and that the controller should be selected to release a maximum quantity of vapour, if necessary, to maintain the pressure at a constant level. The column pressure is also linked to overhead condensing conditions more or less closely. In the type of operation in which total condensation of the overhead is desired, it becomes necessary to locate the column-pressure controller in the vapour line between the column and the condenser. But in the ordinary case only sufficient liquid to furnish reflux for the column is desired, and the pressure controller is located on the excess-vapour outlet from the reflux accumulator tank. It is apparent that a constant flow of

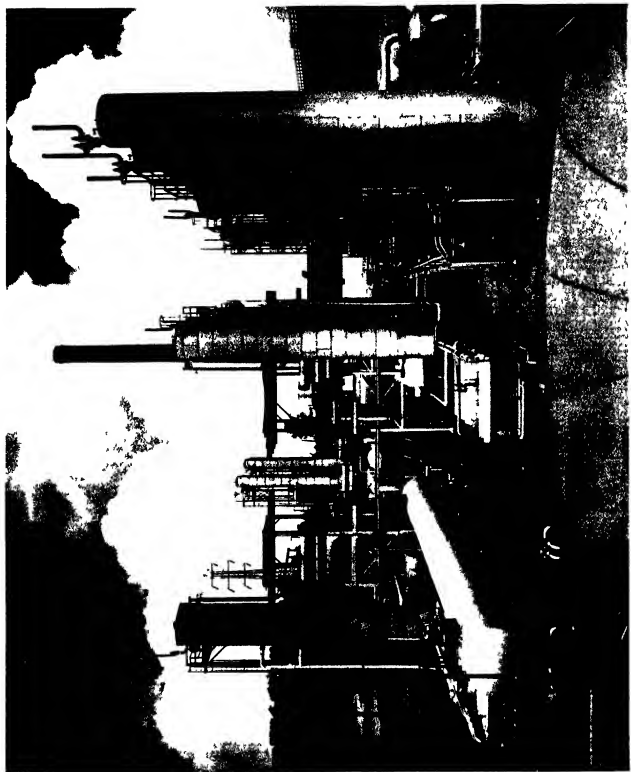

FIG. 4

vapours at this outlet is a result of smooth operation, and since these vapours exist at or about equilibrium condensation conditions, fluctuations in either their temperature or pressure are to be avoided, and the selection of the type of control for maintaining the supply of reflux liquid requires careful consideration

Conclusion

In the foregoing pages an attempt has been made to present in a workable form the fundamental laws and processes, as well as methods of their application, which form the basis of modern engineering practice in the design of commercial plants for the recovery and stabilization of gasoline from petroleum gases. Many important details received only cursory mention when authoritative literature on the subject was easily available for reference. The writer has recognized the fact that much of the published literature on the subject is of a theoretical or general nature, and has tried to draw upon his own experience for those practical factors which are so essential to the logical solution of many of the problems confronting the engineer. However, in several instances it was impossible to supply specific experience factors on account of the more or less intangible nature of the problem, and consequently it was necessary to be content with the offering of guiding suggestions designed to help the engineer in making assumptions and in checking their reasonableness.

Practically all the discussion has been on the design of individual units without regard to a possible operating relationship to other units in a plant. This is a matter which requires most careful consideration in each particular case, but does not lend itself to general analysis, the governing factors being established by the combination of a large number of local circumstances and conditions. For example, in the large vapour-recovery and stabilization plant shown in Fig 4 there are five independent plant units operating at the same pressure and interlocked in so far as their pressure control is concerned. Likewise, there are four or five continuous streams of stabilized or fractionated

material produced from the plant, and these streams are blended together continuously in the proper proportions to yield desired final specifications in the finished products as regards vapour pressure, and, to some extent, distillation range and 'knock' rating characteristics. It is obvious that in designing a plant such as this, the interrelation of units has a marked influence on the selection of controllable operating conditions. Likewise, capacity ranges of individual units must be considered very carefully, since it is possible for one unit to defeat the effective utilization of the operating flexibility of other units. It might be suggested that this difficulty could be eliminated by divorcing the various units, and considering them individually such as would be the case in a single unit plant. While this is possible, there is a distinct advantage to be gained by correlating the units, both in the overall efficiency of the plant and in the ease of operation, number of men required, and closeness of supervision.

No separate discussion of 'compression' plants was considered necessary, since the theoretical basis and methods of calculation are identical with those described. A compressor is only a mechanical device for increasing the working pressure of a gas or vapour system, and the engineer must rely on his judgement as to the economics of its use in the process under development in each particular case. The same thing is true of refrigeration. The control of temperature and pressure conditions which these subsidiary processes make available to the engineer greatly broadens the scope of the practical application of the fundamental processes to industrial problems. The industry in general is beginning to recognize the possibility of this much broader operating range, and the trend is towards multi-product plants, separating by close fractionation those special materials which are readily available in the vapour-recovery and stabilization plant, such as pentane, butane, propane, propylene, and even ethane and ethylene. The market for these products is being developed slowly, but is already becoming a major factor in the industry.

REFERENCES

- 1 BROWN, G G, SOUDERS, MOTT, JR, and NYLAND, H V *Ind Eng Chem* 24, 522 (1932)
- 2 GURWITSCH, L. *Wissenschaftliche Grundlagen der Erdölverarbeitung*, 162 (1913) (Also see Moore's English translation, 372 (1932))
- 3 HAUBRANDT, E. *Evaporating, Condensing and Cooling Apparatus*, 140 (1929)
- 4 KREMSER, A. *Proc Calif Natural Gasoline Assoc* v 2 (Feb 1930) (Reprinted in *Petr World*, March 1930)
- 5 MCCABE and TITELLE. *Ind Eng Chem* 17, 605 (1925)
- 6 SOUDERS, M, and BROWN, G G. *Ind Eng Chem* 26, 98 (1934)
- 7 WALKER, W H, LEWIS, W K, and MCADAMS, W H. *Principles of Chemical Engineering*, 684 (1927)
- 8 ————. *Ibid* 702 (1927)

SECTION 24

NATURAL AND REFINERY GASES

The Composition of Natural Gas

A R BOWEN

Helium

F A PANETH

**Occurrence and Production of Helium in
the United States**

R R BOTTOMS

The Analysis of Petroleum Gases

H M STANLEY

**The Utilization of Liquefied Petroleum
Gases**

G G OBERFELL and T W LEGATSKI

THE COMPOSITION OF NATURAL GAS

By A. R. BOWEN, D.Sc., Ph.D., F.I.C., M.Inst.P.T., A.I.Chem.E.

Principal, Technical College, Newark-on-Trent, England

Introduction

This term 'natural gas' is understood to refer to the accumulations of gas, often in enormous quantities, which occur underground in reservoirs of porous formations sealed by more impervious rocks. This gas, which is usually largely hydrocarbon in composition, may occur in such geological formations either with or without association with petroleum deposits.

Its origin has been the subject of a considerable amount of discussion and will be referred to at length in the article on the origin of petroleum.

The two general natural processes that evolve gases are the fermentation and decomposition of organic matter and the inorganic reactions that take place at high temperatures. Fermentation and decomposition of organic matter can give different types of gases depending on the conditions, for example, the bacterial fermentation [47, 1928] of sewage sludge evolves a gas containing about 70% of methane, the remainder being carbon dioxide and nitrogen, again, the decomposition of straw by sewage bacteria results in the formation of a gas containing 90% of methane and 10% of hydrogen.

Another gas thought to be a decomposition product of recent origin has been described by W. G. Woolnough [58, 1934], who has pointed out that the evolution of gas in large amounts is associated with the periodic reappearance of a transient mud island in Lake Victoria, Gippsland, in the State of Victoria, Australia. This author considers the gas to be of recent lacustrine origin, and its composition has been found to be

Carbon dioxide	24.4
Oxygen	0.8
Methane	62.5
Nitrogen	12.3

Volcanic gases [13] do not present many features in common with the natural gases not associated with volcanic activity. The former contain mainly steam, but also such constituents as hydrogen, oxygen, nitrogen, argon, helium, hydrogen sulphide, sulphur dioxide, carbon dioxide, carbon monoxide, hydrogen chloride, chlorine, methane, hydrogen fluoride, and silicon fluoride, and appear to vary in composition with the time elapsed since the volcanic eruption and the distance from the volcanic centre.

Analyses of such gases thus in some cases showed small contents of methane, e.g. gases from fumaroles in the Katmai region, Alaska, contained steam 98.8-99.99% and residual gases of composition.

	(1)	(2)
	%	%
Carbon dioxide	24.3	52.8
Oxygen	3.4	2.3
Carbon monoxide	0.2	0.5
Methane	0.1	8.5
Hydrogen sulphide + hydrogen	25.3	20.5
Nitrogen and argon	4.67	15.4

Earthquakes have been found to affect the composition of natural gases [15, 1924]

Before considering the main subject of this article, namely, the chemical composition of natural gases, a few remarks on the nature of gases occluded in coal and rocks of non-volcanic origin will serve to show the similarities and contrasts in these various naturally occurring gases.

The inflammable gas frequently met in coal-mines and known as firedamp consists mainly of methane. It exudes on release of pressure from adsorption in the coal or from cavities in the coal and surrounding strata. The quantity of firedamp which is discharged from the coal face into the ventilation current of a mine varies considerably, and an instance has been quoted [44, 1927] that, from one colliery, over 10 million cu ft per 24 hours were discharged daily for a limited time during the normal operations of coal-mining. Pressures of gas in boreholes have been recorded up to 461 lb per sq in. This gas emission falls off as coal seams are progressively worked. Variations in barometric pressure and earthquake movements affect the emission of firedamp. Firedamp is emitted from exposed coal surfaces not only by the normal exudation, but also by sudden 'outbursts' and more prolonged 'blowers' from vents and fissures in the strata. Such 'blowers' may continue for years, and in this way continuous supplies of almost pure methane have been obtained in South Wales, which gas has been used for lighting, power, and other purposes.

Carbon dioxide is also occluded by some coals and is emitted in a similar manner to firedamp.

Some analyses of gases obtained from coal seams have been given [31]

TABLE I

	A blower, S. Wales %	After an outburst, S. Wales %	Borehole, Lancs %
Carbon dioxide	3.00	0.19	3.52
Combustible gas (chiefly methane)	93.9	99.8	87.1
Carbon monoxide			0.01
Nitrogen	3.1		9.4

Traces of ethane have sometimes been found with the methane of these gases.

In non-volcanic rocks small quantities of occluded gases [13] have been detected, for example

Gas from a Connecticut smoky quartz	carbon dioxide = 98.33%, nitrogen = 1.67%, with traces of hydrogen sulphide, sulphur dioxide, ammonia, and a fluorine compound,	
" "	a Canadian calcite	hydrogen sulphide,
" "	Wieliczka rock salt	methane = 84.60%, nitrogen = 10.35%, with oxygen and carbon dioxide,
" "	a zircon	helium and argon,
" "	uraninite and rare earth minerals	helium

Rocks such as granite, gabbro, pyroxene gneiss, corundum gneiss, and basalt will evolve, on heating, small amounts of carbon dioxide, carbon monoxide, methane, nitrogen, and hydrogen. On heating rocks, much of the gas that is evolved can probably be accounted for by the chemical breaking down of the rock constituents.

Although not occurring in large quantities, the gases that have been found associated with metamorphic rocks present peculiar features. W G Woolnough [59, 1934], in discussing Australian gases, states that there are some interesting occurrences of inflammable gas genetically associated with metamorphosed sedimentary rocks and with crystalline schists. Inflammable gas occurs in the deep mines of Kalgoolie, Western Australia, where natural gas under pressure has been encountered in several places in the mines of this goldfield. Two analyses of such gas are given

	(1)	(2)
	%	%
Carbon dioxide	0.28	0.33
Oxygen	5.36	7.70
Methane	56.50	42.50
Nitrogen (by difference)	37.86	49.47

In similar gases from southern Yorke's Peninsula, South Australia, high contents of hydrogen have been recorded. Gases from igneous rocks [49, 1932], pre-Cambrian rocks [6, 1932], and shales [11, 1929] have also been described. Woolnough describes many types of gases from other formations in Australia including those occurring in the Great Artesian Basin, Queensland, where, essentially, two types of gas are encountered, namely, inflammable gases composed mainly of methane, and gases almost entirely composed of nitrogen.

Of the theories put forward to account for the origin of natural gas and oil the organic theory has the most support, and shales with contents of organic matter are considered to give up their oil and gas products to porous sandstones or limestones in their vicinity. For the accumulation of large amounts of gas and oil, in these porous rock reservoirs, impervious overlying strata are necessary. The mechanism of the segregation of oil and gas from the natural brines of the porous formations, usually with the gas occupying the highest, the oil the intermediate, and the brine the lowest levels in the strata, and accumulation, is considered to be influenced by many factors including gravitation, capillarity, and the uneven pressures in folded strata.

By virtue of its usually high hydrocarbon content, natural gas constitutes an important source of fuel.

The occurrence underground of natural gas capable of use as fuel has been known from the earliest times. In China, wells are stated to have been drilled for gas many hundreds of years ago, and fires from gas issuing from fissures in the ground in regions around the Caspian Sea have been the object of ancient worship.

The manner in which natural gas escapes from the ground can vary with the conditions concerned. Such seepages of

gas have been described by L. Dudley Stamp [20, 1934] in discussing the natural gas of Burma. The mud-volcanoes of Burma are famous, and such exudations of large bubbles of gas, bringing up mud which forms small cones, are characteristic of many other petroleum districts. D. Dale Condit [17, 1934] describes gas seepages in India and Baluchistan. The analysis of a gas from a mud-volcano near Ormara, Baluchistan, has been given as

	%
Methane	74.5
Ethane and other hydrocarbons	9.6
Carbon dioxide	1.4
Oxygen	0.7
Nitrogen	13.8

Some interesting analyses of gas seepages in Russia are included in the report of S S Nametkin, A S Zabrodina, A S Karkonas, D N Kursanov, V A Sokolov, and S P Uspenski [46, 1932], and are reproduced in Table II.

Large quantities of gas are found in Burma, and one well at Pyayé issuing gas for some months in 1928 was estimated to be losing 39 million cu ft per day.

In the United States of America natural gas was used commercially at Fredonia, New York, as early as 1821 and for industrial purposes in 1863 at East Liverpool, Ohio. G. A. Burrell [8, 1925, 1928] states that one of the first natural-gas pipelines was built in 1876 to supply Titusville, Pennsylvania, the gas being transported 5 miles through a 2-in. pipe. Development proceeded during the years 1880-90 and natural gas became of some economic importance, and at that time many towns in Pennsylvania, Ohio, and West Virginia were supplied with gas. Gas-wells were drilled in Kansas in 1882, in California, gas was utilized in 1890, and in Texas, some of the principal discoveries of gas were made between 1901 and 1903.

To-day gas is piped hundreds of miles from oil- or gas-fields to industrial centres. The figures of the United States Bureau of Mines Report on Natural Gas in 1931 [33, 1933] are of interest. It is stated that the steady expansion which characterized the natural-gas industry in that country during the past decade was interrupted in 1931 when the total marketed production of natural gas was 1,686,436,000,000 cu ft (i.e. approx one trillion, six hundred billion cu ft in French and American nomenclature, or one billion, six hundred thousand millions cu ft in English nomenclature). Of the total consumption of natural gas in the United States in 1931, namely, 1,684,249,000,000 cu ft, 34% was used for field purposes, 23% for domestic and commercial purposes, 12% for carbon black, 8% at electric public-utility power plants, 4% at petroleum refineries, 2% at cement plants, and 17%

TABLE II
Gases in the Taman Peninsula
(Nametkin, Zabrodina, Karkonas, Kursanov, Sokolov, and Uspenski)

Locality	Composition of gas					
	Air %	Carbon dioxide %	Methane %	Ethane %	Propane plus %	Non-combustible gas %
Karabotvka (whole well was throwing out emulsion)	4.2	35.5	58.8			1.5
Pekia Peninsula (with ejection of mud)		26.3	73.7			
Bugaz (periodic gas from mud-volcano)		10.4	89.2			
Gnilaya (periodic gas from mud spring)		0.4	99.6			
Gnilaya		1.5	89.8			8.7
Zaimbali (gas from mud-volcano)		2.2	97.8			
Nefelnsaya (weak gasing)		6.1	82.1	2.1		9.7

for general industrial purposes Exports of gas to Canada and Mexico totalled 2,231,000,000 cu ft in 1931, and imports totalled 44,000,000 cu ft

The figures quoted cover only gas marketed and do not include gas blown into the air or the large quantities of 'unaccounted-for' gas lost in transmission

Gas-wells have been drilled to establish reserves for the large pipeline systems

Of outstanding interest among the developments in the natural-gas industry was the construction in 1931 of the Panhandle (Texas)-Chicago pipeline

Composition of Natural Gas

One of the first systematic studies of the composition of natural gases was made by G A Burrell and G G Oberfell, who published the results of the analyses of samples of natural gas from 25 cities in the United States in 1914. Since that time many analyses have been put forward

Natural gases are roughly classified according to their content of light liquid paraffin hydrocarbon vapours A 'dry' gas contains less than 0.1 gal of gasoline for 1,000 cu ft, a 'lean' gas 0.1-0.3 gal per 1,000 cu ft, and a 'wet' gas 0.3 gal per 1,000 cu ft or more

Types and Varieties of Natural Gases (H A Ley [58, 1935])

	1	2	3	4	5	6	7	8	9	10
<i>Constituents</i>										
Methane, %	99.2	87.04	73.14	58.7	0.6	8.0		9.83	10.6	36.7
Ethane, %		4.13	23.81	16.5		0.6		27.58	1.6	14.5
Propane, %		2.56		9.9			21.8	41.57		23.5
Butane, %		2.00		5.0			77.7	19.7		14.9
Pentane and heavier, %		3.42		3.5						10.4
Nitrogen, %	0.6		2.85		6.5	90.9	0.5	1.14	85.6	
Carbon dioxide, %	0.2	1.11			91.2	0.1			0.1	
Hydrogen sulphide, %				6.4	0.2					
Helium, %									2.13	
<i>Type</i>	Hydro-carbon	Hydro-carbon	Hydro-carbon	Hydro-carbon	Carbon dioxide	Nitrogen	Hydro-carbon	Hydro-carbon	Nitrogen	Hydro-carbon
<i>Variety</i>	'Dry'	'Wet'	'Sweet'	'Sour'	'Ice'	'Wind'	Domestic bottled gas	Industrial bottled gas	Helium	'Casing-head'

In 1930 there were 65,000 miles [29, 1931] of gas pipelines in the United States, and the gas reserves of that country have been estimated [55, 1931] at 100,000,000,000 cu ft, or perhaps over twice this amount

In Canada [34, 1928] gas has been produced in New Brunswick, Ontario, Alberta, and a small amount in Manitoba In 1924 the Royalite no 4 Well, Turner Valley, Alberta, came in with a gas-flow of 17 to 20 million cu ft per day High-grade naphtha of 72-73° B_e was extracted and the gas piped to Calgary for domestic and industrial uses

A well-known gasfield occurs in Transylvania, investigated chiefly in the years 1906-18, formerly in Hungary, the territory is now Roumanian

This gas is dry, being mainly methane, and is found over a wide area, the 6 main districts being Sarmashel, Samshud, Zahul, Saroshul, Bazna, and Copsa-Mica [43, 1931-2] N N Stefanescu [52, 1934] has stated that in the Transylvania region at least 80 salt-domes are known as gas producers The gas contains 98% of methane and has a density of 0.5 There are 7 known gas-producing strata, of which only 3 were then in production, the deepest 4 being held as future reserves The depths of the gas-producing formations vary from 600-3,000 ft, and the pressure is up to 1,000 lb per sq in He states also that the total production of gas in 1933 was 6,100,000,000 cu ft Three pipelines are in existence for the conveyance of the gas [30, 1934, 43, 1931-2] to industrial centres

The gases encountered in the oil-producing districts in Roumania are met often under high pressure. These gases are used for power and gas-lift purposes

In Hungary there are a few small gas-wells giving 3,000-5,000 cu m of gas per day which is used in heating and lighting in the towns of Hajduszoboszló, Karczag, and Debreczen In England gas has been encountered in the drilling at Hardstoft, Derbyshire, and at Heathfield, Sussex.

Natural gas is, for the most part, composed of the hydrocarbons of the paraffin series, carbon dioxide, nitrogen, and, occasionally, helium Natural gases from some parts of Kansas, Oklahoma, and Texas contain appreciable quantities of nitrogen with proportions of helium also Some of the natural gases of the Pacific Coast of the United States and of Mexico contain large percentages of carbon dioxide In some districts natural gas also contains hydrogen sulphide and organic sulphur compounds Occasionally wells produce almost pure carbon dioxide or almost pure nitrogen Methane is the usual chief constituent, and this can be present in some cases as practically the only hydrocarbon present, e.g. in proportions up to 98-99% of the total Hydrogen, carbon monoxide, oxygen, acetylene, and olefines are, according to Burrell, not constituents of natural gas, but carbon monoxide and hydrogen have been recorded in some analyses The other paraffins, ethane, propane, butane, isobutane, pentane and isopentane, hexanes, heptanes, and possibly octanes can be present, but the higher the molecular weight the less is the proportion Cyclopropane and cyclobutane and other naphthene hydrocarbons, e.g. cyclopentane (which has been identified in petroleum), may also possibly be present [5, 1924] in gas associated with some oils, however, in certain United States natural-gas gasolines [3, 1929], *n*-butane, *n*-pentane, isopentane, and tetramethyl-methane (neopentane) and small amounts of trimethylethyl-methane, diisopropyl, and dimethylpropyl-methane have been reported with no cyclic hydrocarbons boiling below the hexanes Other investigators have failed to find neopentane With highly aromatic light crude oils, vapours of benzene and toluene would be present in the associated gas Benzene, toluene, and *m*-xylene have been found in natural-gas gasoline [28, 1926].

R P Anderson and A M Erskine [1, 1924] have reported the presence also of 2-methyl-pentane, *n*-hexane, *n*-heptane, 2-methyl-hexane, and octane in natural-gas gasoline.

In the United States natural gas used with or without admixture with oil gas has, to obtain a standard quality of gas, in some cases been subjected to cracking, or partial cracking, before use for city distribution. This re-forming of natural gas is described by W W Odell [48]. In this cracked gas, constituents such as hydrogen and illuminants are present.

Natural gas accompanies oil in the strata, although most natural-gas wells do not yield oil. In the older oilfields, such as some Pennsylvanian fields, oil has been produced long after the gas pressure has almost entirely disappeared, while certain formations continue to yield gas under high pressure, with practically no diminution from the beginning until the end of the life of the well as regards its oil production, as has been experienced in some Mexican oilfields.

Burrell has pointed out that natural gas associated with oil in the structure incorporates some of the lighter liquid hydrocarbons. The gases from the heavier crude oils with little or no gasoline content, such as some of the Coastal crudes of Texas, have only very small proportions of gasoline vapour. Gas associated with oils rich in gasoline and where the gas pressure is approaching exhaustion contains high proportions of gasoline vapours. The chief factors which determine the gasoline content of a gas are the content of light constituents in the crude oil, the well pressure, and the intimacy of the gas-oil contact.

The importance of the pressure factor is evident. Gas wells can have original pressures of the order of 1,000 lb per sq in., under which conditions little gasoline vapour can be present in the gas. As the pressure in the stratum diminishes, through withdrawal of gas, the remaining gas becomes increasingly rich in light liquid hydrocarbon vapours.

F W Lake has pointed out that [37, 1930], as yet, a number of physical phenomena connected with the original occurrence and association of oil and gas, and their relative movement through the strata interstices from the reservoir into the well, are at present only little understood. Reservoir pressures originally existing in the deeper producing horizons, such as occur in the Santa Fé Springs

and Kettleman Hills fields, have been as high as 3,000-4,000 lb per sq in. This investigator also points out that gas associated with oil exists underground, depending on the temperature, the pressure, and the nature of the oil as free gas overlying the oil in the higher portions of the strata, dissolved in the oil, adsorbed, in small proportions, at the interfacial surfaces, or as liquid, but as the average natural gas, as produced, contains more than three-quarters its volume of methane and ethane and the critical temperature for methane is very much less than, and that for ethane a little less than, 95° F., it is not probable that much of the gas exists in the liquid form in the average natural reservoir.

With increasing amounts of ethane, propane, and butane in the natural gas, its solubility in oil increases, and, in general, natural gas is more soluble in light than in heavy oils. It is shown by Lake that at a pressure of 1,500 lb per sq in. as much as 360 cu ft of wet natural gas is held in solution per barrel of oil of about 34° API, and that the gas decreases the viscosity of the oil and its surface tension.

P S Magruder [40, 1930] also considers that since the original oil contains the gasoline under the earth pressures, the composition of the crude oil determines to some extent the characteristics of the natural gasoline obtained from the gas with which it is associated. A heavy crude oil rarely contains appreciable amounts of natural gasoline, while crudes of medium specific gravity yield natural gasolines of relatively stable characteristics, propane and the butanes being characteristic constituents of light crude oils.

Table III, given by Magruder, shows some approximate analyses of gases encountered with crude oils of varying specific gravity.

TABLE III

Gravity, °API at 60° F Analysis (% by volume)	20 0	25 0	30 0	35 0
	Methane	96.19	89.80	87.76
Ethane	1.84	5.00	5.30	8.58
Propane	1.46	2.80	3.20	4.75
Butanes	0.13	0.80	1.90	2.79
Pentanes and heavier	0.38	1.60	1.84	2.60

TABLE IV

State	County	Methane %	Ethane (and higher hydrocarbons) %	Carbon dioxide %	Nitrogen %	BTh U per cu ft @° C	Sp gr (air = 1)
Arkansas	Fulton	96.7	0.0	1.0	2.3	1,030	0.57
California	Los Angeles	77.5	16.0	6.5	0.0	1,123	0.70
"	"	59.2	13.9	26.2	0.7	889	0.88
Illinois	Laurens	37.5	59.6	0.0	1.7	1,591	0.86
"	Crawford	95.6	0.0	0.5	3.9	1,018	0.58
Kansas	Allen	96.4	1.1	0.9	1.4	1,051	0.58
"	Butler	10.5	1.64		87.69	129	
"	"	62.2	18.38		18.64	930	
"	Shawnee	88.8	6.7	0.8	3.7	1,070	0.61
Kentucky	Fayette	76.4	22.6	0.0	1.0	1,234	0.67
Louisiana	De Soto	97.3	0.0	0.4	2.3	1,066	0.59
Missouri	Jasper	92.6	4.3	0.6	2.5	1,066	0.59
New York	Allegany	59.8	37.6	0.4	2.2	1,336	0.75
"	Genesee	91.9	6.8	0.0	1.3	1,105	0.59
Ohio	Erle	83.5	12.5	0.2	3.8	1,122	0.63
Oklahoma	Creek	93.1	5.7	0.4	0.8	1,098	0.59
"	Kay	70.7	18.65		9.32	1,025	
Pennsylvania	Blair	90.0	9.0	0.2	0.8	1,126	0.60
"	McKean	32.3	67.0	0.0	0.7	1,591	0.89
Texas	Dallas	50.6	10.9	0.1	38.4	742	0.77
"	Gray Co	84.0	12.0		2.5	1,060	
"	Navarro	98.0	0.0	0.7	1.3	1,044	0.57
"	Tarrant	50.6	10.9	0.1	38.4	742	0.77
West Virginia	Harrison	66.6	32.7	0.0	0.7	1,318	0.72
"	Marion	82.0	17.0	0.1	0.9	1,189	0.64

It can be noted that the lighter oils give up the greater amounts of the butanes to the gas, which results in a more volatile natural gasoline being made from such gases.

Table IV gives some of the analyses of natural-gas samples from the principal fields of the United States given by R. Cross [16, 1931].

The composition of some further natural gases occurring in the United States are given by Cross, Garner, Muller, and Dobbin in Tables V and VI.

TABLE V

	Methane %	Ethane and small amounts of higher hydrocarbons %	Nitrogen %	Carbon dioxide %
Pittsburgh, Pa	79.2	19.6	1.2	
Louisville, Ky	84.7	13.7	1.6	
Buffalo, N Y	77.8	20.4	1.8	
Cincinnati, O	79.9	15.2	4.9	
Cleveland, O	79.8	19.5	0.7	
Springfield, O	80.5	18.2	1.3	
Columbus, O	80.3	14.7	5.0	
Chiles, Okla	80.4	18.1	1.5	
Bartlesville	75.4	17.7	6.6	
Kansas City	92.4	3.1	3.1	1.4
Forth Worth	84.1	5.7	8.4	0.8
Los Angeles	51.5	10.2	38.3	
Little Rock	77.5	16.0	0.0	6.5
Monroe	96.7	2.80	2.3	1.0
	94.69		2.31	0.2

A most comprehensive series of analyses of natural gases occurring in the North American Continent is given by the collected papers of the American Association of Petroleum Geologists [58, 1935]. Unusual gases are quoted in Table VII.

TABLE VII

	Methane %	Ethane %	Carbon dioxide %	Oxygen %	Nitrogen %	Unsat %	Helium %	Hydrogen %	Carbon monoxide %
Colorado (Model)	0.00	0.00	12.19	0.92	79.71		7.18		
Ohio (Thurston)	91.20	1.10	0.20	0.30	2.70			3.70	0.80
Gulf Coast (Jennings)	88.40	1.03	1.80	1.81	5.76				1.40
Michigan	67.90		0.70	1.30	3.5	1.0		25.6	
Kentucky (Meade)	91.7	0.1	0.6		7.3	0.3			

TABLE VIII

Some United States Gas Analyses

Field	Well no	Pressure of gas, lb per sq in abs	Composition of gas, %					Source of sample
			Methane	Ethane	Propane	Butane	Pentane	
Oklahoma City	D	265	87.3	7.9	3.0	1.8		Gas discharged from separator
	D	16	60.4	16.9	13.8	6.3	2.6	Gas from oil discharging from 265 lb per sq in separator to 16 lb per sq in separator
		15	84.3	8.7	4.1	1.7	1.2	Intake gas of gasoline plant.
		38	88.1	7.3	2.8	1.8		Residual gas of gasoline plant
Kettleman Hills	F	1,672	85.6	8.2	3.6	1.6	1.0	Free gas, not in solution at 1,672 lb per sq in pressure
	F	52	51.2	18.5	15.1	9.7	5.5	Gas in solution in a 500 lb per sq in trap and liberated from 52 lb per sq in trap
	G	1,089	84.6	9.0	4.0	1.4	1.0	Free gas, not in solution at 1,089 lb per sq in pressure
Ventura	H	1,000	91.9	3.2	2.9	1.4	0.6	Free gas, not in solution at 1,000 lb. per sq in pressure

TABLE VI

Analyses of Gases rich in Helium and Nitrogen (Dobbin)

State and field, United States	Methane %	Ethane %	Carbon dioxide %	Oxygen %	Nitrogen %	Helium %
Kansas (Dexter) (Augusta)	14.85 10.54	0.41 1.04	0.00 0.13	0.20 0.00	82.70 85.56	1.84 2.13
Oklahoma (Pearson)	51.91	1.12	0.00	0.21	46.36	0.50
Texas (Petrolia)	51.30	10.40	0.10	0.00	37.20	1.00

Some interesting analyses of gases, used in the course of a research on solubility, have been recorded by B E Lindsly [38] as in Table VIII.

It is thus obvious that the composition of natural gas depends to some extent on the conditions under which the sample is taken. Underground waters can contain small amounts of dissolved gases, and such waters have been investigated by G W Jones, W P Yam, and E P Buxton [35, 1923] who endeavoured to show that the content of natural gas might be a possible aid to the petroleum and natural-gas prospector.

Some interesting observations on the nature of the gases from the Panhandle field are given by V Cotner and H E Crum [14, 1933] in Table IX. These investigators point out that there are 'sour' and 'sweet' gases in the Texas Panhandle district. 'Sour' gas is found in the limestone producing areas of the Borger district, and 'sour' gas is also produced in Gray, Moore, Carson, and Potter counties. A 'sour' gas usually contains 5-200 grains of hydrogen sulphide per 100 cu ft., while a 'sweet' gas contains 5 or less grains of hydrogen sulphide. It has been stated that most of the sulphur in the gas from the Granite Wash zone

is in the form of ethyl, propyl, and butyl mercaptans instead of hydrogen sulphide

TABLE IX
Analyses of Panhandle Gas (Cotner and Crum)

	Composite samples, Wheeler County		Gas-well, Carson County %
	No 1 %	No 2 %	
Oxygen	0.22	0.40	0.40
Carbon dioxide	0.00	0.10	0.30
Nitrogen	1.59	2.10	1.80
Methane	92.30	91.25	90.58
Ethane	3.09	2.80	3.70
Propane	1.81	2.09	1.37
Butane	0.93	0.82	1.08
Pentanes and heavier	0.56	0.44	0.57

The hydrogen sulphide content of gases in some United States oilfields has been discussed by J M Devine and C J Wilhelm [18, 1931]. Certain gases from Texas were found to be rich in this constituent, and the highest figure quoted is 20.50% by volume of hydrogen sulphide in the gas of a pumping well in the Roberts-Settles field in the Howard and Glasscock counties, Texas.

Natural gas from reservoirs on the Bush dome in Potter County is stated to contain 2% of helium.

Canada is an important producer of natural gas. E H Boomer [23, 1930] has discussed the utilization of Alberta natural gas. The Turner Valley area produces a 'wet' gas containing a relatively small proportion of naphtha. These gases are stripped of their naphtha content, and the residual gas, mostly methane, has been to a great extent burned in the field. Thus some 60,000 cu ft of gas are destroyed for each barrel of naphtha obtained. About 75,000,000 cu ft of gas are used per day in the neighbouring cities, this figure being not more than one-eighth of the total gas available. Apart from this field, there are in the province of Alberta many dry gas-wells, at present capped and conserved, awaiting utilization. In 1926 the possible daily production of these dry gasfields was estimated to be in excess of 400,000,000 cu ft.

R T Elworthy [24, 1921, 25, 1924] has given some analyses of typical Canadian natural gases in Tables X and XI.

TABLE X
Analyses of some Canadian Natural Gases

	Methane %	Ethane %	Oxygen %	Carbon dioxide %	Nitrogen %	Helium %
Stony Creek, Monkton, N B Simcook, Ont	80.0	7.2			12.8	0.06
Don Nat Gas Co	80.3	7.6		0.3	11.8	
Askaw well, Til- bury tp, Kent Co	84.4	10.8	(H ₂ S 0.3)		4.5	0.18
Fairbanks well Emskilton tp, Lambton Co., Ont	68.3	15.9			15.8	0.15
Welland no 2, Berte tp, Ont	80.0	12.9	0.2		7.1	
Medicine Hat city gas	90.0	3.0	0.1	0.8	5.0	0.11
Bow Island, Barnwell well no 25	88.3	3.7			7.0	0.36
Sheep River Cal- gary Petroleum Products well nos 1 and 2	72.0	16.7			11.3	
Viking, Alberta	94.0		0.4	0.6	5.0	0.05
Pelican Rapids, Athabaska River	97.0			1.2	1.8	0.002
Kamloops B C	96.8			0.3	2.9	

The helium content of Alberta and Ontario natural gases has been investigated by R T Elworthy [26, 1926] who found small proportions, the figures ranging from about 0.009% helium content of the deep horizon gas of Royaleite no 4 Well, Turner Valley, to about 0.82% helium of the gas from Caledon, West Peel County, Ontario.

Other analyses of some gases from the Turner Valley, Alberta, have been recorded by P V Rosewarne, W P Campbell, and R J Offord [50, 1933], Table XII, and show the important content of gasoline vapour.

Analyses of natural gases from the oilfields of Iran have been given in several communications. These gases, similar to some American gases such as from south-west Texas (Big Lake and Crane-Upton fields) and Mexico, have high contents of hydrogen sulphide, often about 10% by

TABLE XI
Analyses of Alberta Natural Gases

Field	Source	Specific gravity	Methane %	Ethane %	Carbon dioxide %	Oxygen %	Nitrogen %	Gasoline, gal per 1,000 cu ft
Medicine Hat	City Mans	0.56	97.8	0.3	0.4	0.0	1.5	
Many Islands Lake	Medicine Hat Devel Co	0.57	95.6	0.0	0.2	0.1	4.1	
" "	Can Amer Oil Co	0.58	96.3	0.5	0.5	0.3	2.4	
Bow Island	Pipeline	0.59		91.6	0.0	0.2	8.2	
" "	"	0.60		90.3	0.0	0.0	9.7	
" "	Well no 22		90.1	2.6	0.0	0.0	7.3	
" "	Well nos 9 and 10		89.2	0.9	0.0	0.0	9.6	
" "	Well no 25		86.2	4.3	0.0	0.0	9.5	
Barnwell	" "	0.61	94.2	0.8	0.3	0.3	4.4	
Foremost	Edskin well	0.57	95.4	0.0	0.3	0.0	3.7	
Crugglye	S Alberta Well no 2	0.86	52.0*	45.1*	1.4	0.8	0.7	0.7
Turner Valley	Illinois Alberta no 1	0.72	67.4*	30.0*	1.0	0.2	1.4	0.3
" "	Royalite Oil Co Well no 1	0.70	71.8*	25.9*	2.1	0.3	0.9	0.2
" "	" " " 3	0.71	67.2*	30.3*	1.7	0.0	0.8	0.3
" "	" " " 4	0.73	65.9*	24.4*	1.2	2.0	6.5	0.2
Viking	Well no 6	0.64	92.5	3.5	0.5	0.1	3.4	
Wainwright	Brit. Petrol Well no 1	0.62	87.3	4.4	0.3	1.0	7.0	
" "	Imp Oil Co Fabyan no 1	0.61	88.6	2.6	0.3	0.8	7.7	

* Hydrocarbons recorded as methane and ethane, but probably containing propane and butane

TABLE XII
Gases from Turner Valley

Name and no of well	Methane %	Ethane %	Propane %	Butanes		Pentanes plus %
				iso %	Normal %	
Dalhousie, no 7	32.52	13.55	21.68	6.78	12.74	12.74
Foodilla, no 1	32.27	13.55	21.61	6.79	13.86	11.94
Lowry, no 1	37.85	17.80	20.05	5.65	9.04	9.60
Mesland, no 1	31.35	11.14	24.10	8.13	14.75	10.54
Mezeury, no 1	26.10	12.70	21.10	7.70	15.70	16.70
Royalist, no 25	38.60	15.28	19.30	5.63	10.72	10.45
Wellington, no 1	34.25	17.47	20.54	6.51	9.93	11.30

volume. An explanation of this hydrogen sulphide content of Iranian gas has been put forward by W H Cadman [9, 1925], who showed experimentally that Iranian natural gas, freed from hydrogen sulphide, will react on heating not only with elemental sulphur, but also calcium sulphate (anhydrite and gypsum) to form hydrogen sulphide. Oil-field waters have been shown to contain sulphate-reducing bacteria which might account for some hydrogen sulphide.

A E Dunstan [21, 1924] points out that Iranian gas contains traces of argon, but no helium, and gives [22, 1928] an analysis of gas separated at 400 lb per sq in pressure

Hydrogen sulphide	0.9% by volume
Carbon dioxide	0.35% "
Oxygen	0.25% "
Paraffins	96.36% " (methane 80.2% ethane 16.16%)

Other figures of gases separated at high and low pressure are also given in Table XIII

TABLE XIII
Iranian Natural Gas

	High-pressure gas %	Low-pressure gas %
Hydrogen sulphide	0.9	7.8
Oxygen and carbon dioxide	0.7	1.94
Nitrogen	1.4	1.7
Methane	81.0	36.0
Ethane	16.0	32.0
Propane	"	9.0
Butane	"	9.0
Pentane	"	6.0
Density (H = 1)	11.8	16.7

Further figures have been given by S J M Auld [2, 1928] in Table XIV

Recently W H Cadman [10, 1934] has given more

Analysis of Natural Gases from Other Parts of the World

TABLE XVI
Poland (Kling and Suchowak [36, 1928])

Locality	Carbon dioxide %	Oxygen %	Methane %	Ethane %	Nitrogen %	Other Constituents
Bitków Well 134	3.31	0.92	90.90	9.75	0.09	
" " Gusher	3.80	1.94	83.19	5.30	3.76	
Boryslaw Well Bank 18	1.52	0.03	70.69	27.76	0.00	
" " Tadeusz	1.22	2.08	"	93.34	3.35	
Mępska " Michal 5	0.00	0.00	"	96.58	3.42	(Practically all the gases from the Carpathian lowlands contain helium in very small quantities, not exceeding 0.05%).
" " Michal 2	0.00	0.00	"	96.58	3.62	
Polanka " Gaz 6	0.00	7.38	"	63.95	28.67	
Krosno " Winnica 3	0.70	0.00	"	95.66	3.64	
" " Króscienko 43	1.90	0.00	"	96.80	1.30	
" " Króscienko 6	0.63	0.00	"	96.34	3.03	

TABLE XIV

	High-pressure gas %	Low-pressure gas %	Total %
Methane	71.0	35.5	41.4
Ethane	21.0	31.5	29.8
Propane	"	8.5	7.1
Butane	"	5.5	7.1
Pentane	"	8.5	4.6
Hydrogen sulphide	5.5	10.5	9.7

details on Iranian natural gases, as obtained before and after gasoline extraction, which he classifies as follows

(1) High-pressure gas is that part taken from the high-pressure separators operating under the natural pressure of the oil

(2) Low-pressure gas is separated from the crude oil when the latter is reduced to approximately atmospheric pressure. This separation is made in flow tanks at 3-6 in of water pressure

This gas is stripped of its gasoline content, thus

(a) Unstripped gas is low-pressure gas which has not had its gasoline removed by absorption or compression

(b) Stripped gas is low-pressure gas from which gasoline has been removed

(3) Accumulator gas is obtained during the removal of gasoline and consists mainly of propane and butane

TABLE XV

	High-pressure gas %	Unstripped low-pressure gas %	Stripped low-pressure gas %	Accumulator gas %
H ₂ S	4.0	12	12	11.5
Methane	76	29	40	2.5
Ethane	18	24	21	5.0
Propane	1	21	18	44.0
Butane	1	4	9	35.0
Pentane+	"	4	trace	2.0

Discussing methods for desulphurization of gas [4, 1900, 1915, 1922, 1931, 7, 1929], W H Cadman summarizes the methods as

(1) Partial oxidation by means of a Claus-Chance type plant

(2) Washing with sodium sulphide solution and re-acidifying the solution with air

(3) Water-washing the gas under pressure

(4) Other methods including (a) Koppers sodium carbonate process, (b) triethanolamine, (c) alcohol or glycerol

THE COMPOSITION OF NATURAL GAS

1507

Other analyses are given by K. Tolwinski [57, 1934]

TABLE XVII
Average Value of Gas Analyses in Boryslaw and Daszawa (K. Katz)

Well	Locality	Company	Depth, metres	Carbon dioxide %	Oxygen %	Hydrogen %	Paraffins %	Nitrogen %
BORYSLAW								
Zuzanna 1	Mrazuca	B Roth	1,479	0 60	3 16	0	92 70	3 54
Zygmunt 4	"	Galcja	1,467	0 63	4 24	0	88 66	6 47
DASZAWA								
Polmin 6	Daszawa	Polmin	317	0 11	2 17	0	94 64	3 08
Basowska	"	Gazolna	490	0 06	2 02	0	95 19	2 73
Smialy	"	"	740	0	2 33	0	94 23	3 44
Polmin 4	"	Polmin	775 6	0 15	2 13	0	94 16	3 56

TABLE XVIII
Russia (Sokolov [51, 1930-1])

Locality	Air %	Carbon dioxide %	Methane %	Ethane %	Propane %	Butane %	Higher hydrocarbons %
Surakhm	1	18 2	77 5	2 0	0 8	0 5	
Grozni	1	51 8	107 7	25 1	8 8		1 9
Dagestanskje Ogni	1	7 5	89 0	1 9	0 6	0 6	

Kara-Chukhur [56, 1932] Carbon dioxide 0 3-4 6%, hydrocarbons 72 5-98 4%, nitrogen 0-22 1%

Further analyses of Russian oilfield gas have been reported by S S Nametkin, A S Zabrodina, A S Karkonas, D N Kursanov, V A Sokolov, and S P Uspenski [46, 1932] as in Table XIX

TABLE XIX
Russia

Locality	Air %	Carbon dioxide %	Methane %	Ethane %	Propane %	Butane %	Higher hydrocarbons %
<i>Baku region</i>							
Surakhm	1 0	18 2	77 5	2 0	1 3	reckoned with propane	
"	0 8	15 4	80 4	2 2	1 2	"	"
"	1 0	19 5	76 3	2 0	1 2	"	"
"	1 5	19 3	73 7	3 0	2 5	"	"
"	1 5	15 2	79 8	2 2	1 3	"	"
"	1 5	4 3	90 7	2 5	1 0	"	"
Ramani	4 0	16 6	75 5	2 7	0 8	0 7	0 7
Sabunchi	5 0	8 8	84 6	0 9	0 2	0 2	0 3
"	12 5	11 5	75 0	0 7	0 3	reckoned with propane	
Balahm	4 0	11 5	83 7	0 6	0 2	"	"
"	3 5	14 6	80 9	0 6	0 4	"	"
Puti	1 0	13 2	81 3	1 6	1 4		1 5
Bibi-Eibat	0 5	6 3	90 7	2 1	0 4	reckoned with propane	
Subany	1 0	2 0	92 9	2 1	1 0	0 5	0 5
Kala	2 5	0 3	94 4	2 1	0 3	0 3	0 4
Bereky	2 0	1 6	93 3	2 3	0 5	0 1	0 2
Em-Kishlak	4 5	0 4	94 9	0 2	0 2	reckoned with propane	
<i>Dagestan region</i>							
Dagestan Ogni	1 0	7 6	89 0	2 0	propane-butane		higher hydrocarbons
"	1 0	7 8	88 2	1 9	1 0	0 1	non-combustible gas
"	0 7	7 9	87 6	2 8	1 0		
Duslak	2 0	13 7	82 1	1 5	0 4	0 3	
Bereky	0 5	9 9	86 2	2 3	0 9	0 2	
<i>Grozni region</i>							
Old Grozni gp IV		0 4	57 6	16 8	(propane)		15 0
New Grozni gp V			54 9	16 0			7 2
" gp V sub-gp I			53 1	10 3			8 7
<i>Melitopol region</i>							
Georgievka			85 9				14 1
"			99 1				0 9
"			99 0				1 0
Pokrovka II (northern part)		0 2	99 8				

TABLE XX
Romania

Locality	Methane %	Nitrogen %	Oxygen %
Sarmas, Transylvania [27]	99.2	0.8	
Sarmas (no 11) Transylvania [12]	99.10	0.36	0.54

There are typical dry gases from the Transylvanian gas-field. The gases associated with petroleum in the Rumanian oilfields show the characteristics of usual oilfield gases. I. I. Gardescu [30, 1934] gives an analysis of gas from Arsecest

Methane	%
Ethane	95
Carbon dioxide	2
	3

and the analysis of natural gas produced with the oil from the Meotian Thurd sand at Moreni is shown as follows

Methane	%
Ethane	74.0
Propane	10.8
n-Butane	4.2
iso-Butane	3.0
Pentane	2.0
Carbon dioxide	4.0
	2.0

Traces of carbon monoxide, nitrogen, sulphur, and helium

Germany

Natural gas in Germany has been discussed by H. Stille and H. Schlüter [53, 1934]. At Volkenroda in Thuringia gas analyses show the following average composition

Methane 54.5%, ethane 12.4%, propane 9.0%, butane 3.7%, C₄H₁₀ 2.2%, carbon monoxide 0.1%, carbon dioxide 0.0%, oxygen 0.1%, nitrogen 18.0%

Japanese gases have been described by K. Hashimoto [32, 1928], who states that the majority of natural gases produced by the Nippon Oil Company belong either to the pure hydrocarbon type, or to that having a comparatively large content of nitrogen. The former includes the

gas from Nishiyama, Takamachi, Hokkaido, and Kinsui, which gives approximately 1,000 B Th U per cu. ft., while the latter from Nutsu and Akita gives 800-900 B Th U. The natural gas from Shukko, Taiwan, belongs to the carbon dioxide type, containing more than 30% of carbon dioxide.

Recently work has been carried out by B. E. Lindsly [38] on the solubility and liberation of gas from natural gas and oil solutions. This investigator has pointed out the effect of the method of release of the gas on the composition of the gas liberated. The method of releasing gas from solution influences the form of the solubility curves. Flash liberation of gases apparently produces solubility curves that approach the straight-line relationship in accordance with Henry's Law, whereas differential liberation, which causes gradual concentration of the heavier gases in the solvent, produces curved lines when the pressure-volume relationship is plotted on co-ordinate paper. The liberation of gas with release of pressure is analogous to the evolution of vapours from volatile liquids, with the application of heat. In differential distillation, vapours are removed from the oil as formed, differential incremental distillation refers to a series of conditions as just stated and could be regarded as successive-flash distillation. Incremental or flash distillation is single-flash distillation, and liquid and vapour are in contact until equilibrium is established. Single-flash distillation yields greater quantities of vapour at the same maximum temperature than successive-flash distillation owing to the effect of the partial pressure of the lighter components affecting the partial pressure of the heavier components.

An example of gas liberation is quoted by Lindsly. If the bottom-hole pressure is 2,000 lb per sq in, the well-head pressure is 1,000 lb per sq in, and the high-pressure gas-oil separators are held at 500 lb per sq in, the initial flash is 2,000 to 500 lb per sq in, provided that no free gas has been withdrawn between the tubing and casing. The second flash would be in the low-pressure separators held at 50 lb per sq in. The third flash occurs when the oil from the latter separators flows into the flow tanks,

TABLE XXI
England

Locality	Methane %	Ethane %	Propane %	Nitrogen %	Carbon monoxide %	Carbon dioxide %	Oxygen %
Heathfield (Sussex) [54]	93.16	2.94		2.90 (helium = 0.21)	1.00		
Hardtoft (Derbyshire) [46]	93.98	1.04	0.90	[39] 3.93		0.09	0.07

TABLE XXII
France (Moureu [45, 1923])

Origin of gas	Carbon dioxide	Oxygen	Combustible gas	Nitrogen	Rare gases		
					A, Kr, Xe	He and Ne	
Lesquin	0.97			97.756	0.350	0.924	
Molares	0.45	traces		97.99	1.54	0.0111	0.008
Péchebronn Pys no 1 Soufflard	traces			98.40	1.56	0.032	0.008
" Kutzenhaus Sondage no 457	1.49			89.25	9.09	0.154	0.015
" Sondage no 2141	traces			98.98	1.00	0.017	0.003
" no 2183	0.51			98.10	1.36	0.019	0.004
St Barthélemy en Gos (Fontaine Ardéne)	7.3	1.5		81.7	9.37	0.103	0.017
Vaux-en-Bugny (Sondage no 2)	3.3			91.18	5.405	0.019	0.095
Wittelsheim (Mines de Fosse de Mulhouse, Fosse Thoadine)	0.60			96.67	2.69	0.029	0.009

TABLE XXIII
Australia (Woolnough [59, 1934])

Source	Methane %	Ethane %	Propane %	Butane %	Carbon dioxide %	Inert gases %
Queensland, Roma*	87.20	6.03	1.34	1.62		3-49†
Other gases from Roma district						
Well no 14 PFP no 100	83.3	11.4			1.7	1.6
Well no 4 Blythedale	88.1				7.0	0.4
Well no 3 Blythedale	92.0				4.0	3.1
Kawarna Well	76.4				0.6	23.0
Loughagh Oil Well	72.0				9.1	18.9
Westland no 3	89.1				2.1	8.8

* Gasoline can be extracted from this gas

† Contains small proportions of helium

which may be held at atmospheric pressure or a little above single-flash liberation would have occurred if the oil and gas had flowed directly from the well-head to the flow tanks when more of the heavier components, such as pentane and hexane, would have been liberated, since their partial vapour pressures would have been reduced by the presence of large proportions of methane and ethane. When gas was liberated differentially from an oil in the experiments of Lindsley, the API gravity of the oil was 1 to 4° higher than that of the oil when the gas was flash liberated, indicating that more of the pentane and hexane remained in the oil.

The use of the carbon dioxide content of natural gas commercially is of interest. J. C. Miller [42, 1933] points out that, in the United States, gas-wells producing gas containing more than 50% of carbon dioxide as shown in Table XXIV appear to be confined to the Rocky Mountain region. Plant has been erected for 'dry ice' in the McCallum field (Walden), Colorado, and on the Farnham Dome, near Price, Utah.

The wells south of Tampico, Mexico, in the State of Vera Cruz on the Hacienda of Quebrache, give a non-inflammable natural gas under high pressure with some oil. This gas on analysis [41, 1931] shows a content of 95% carbon dioxide and 5% of gasoline vapour, ethane,

TABLE XXIV
Some Carbon Dioxide Contents of United States Natural Gases

		Carbon dioxide %
Montana		
Kovs-Sunburst	Pondera Valley Oil Co Well no 2 Larson	82.33
" "	Advance Oil Co Well no 1 Kitchen	57.75
Colorado		
Garmesha	Gypsy Oil Co no 1	61.05
McCallum	Continental Oil Co no 1 Sherman	91.82
New Mexico		
Jaritas Dome	California Co	67.0
Wagon Mound	Arkansas Gas and Fuel Co	90.0
Estancia Valley	Sinoco Oil Co, no 2 Dehart	97.8
Bueyeros	Kumbeeca Oil and Gas Co no 1 Kerline	98.2
Utah		
Farnham	Carbon Dioxide and Chemical Co no 1	98.3

methane, and a small amount of sulphur compounds. This gas has also been used commercially for the production of solid carbon dioxide. Important information on the non-hydrocarbon constituents of natural gas has been collected by C. E. Dobbin [19] in a paper on the geology of natural gases rich in helium, carbon dioxide, and hydrogen sulphide.

The composition of natural gas, especially concerning the non-hydrocarbon constituents, is an exceedingly interesting subject in geo-chemistry. Constituents such as carbon dioxide and nitrogen might be accounted for in decomposition processes of organic material that are so widely considered to be the source of petroleum and petroleum hydrocarbon gases, but there is a possibility that such constituents may have been derived from quite diverse sources in the earth's crust and have migrated some distance and become mixed in the natural reservoirs in which they are found.

REFERENCES

- ANDERSON, R. P., and ERKINE, A. M. *Ind Eng Chem* 16, 263 (1924)
- AULD, S. J. M. *J I P T* 14, 190 (1928)
- AYRES, E. E. *Ind Eng Chem* 21, 899 (1929)
- CF BOTTOMS, R. R. *Ind Eng Chem* 23, 501 (1931), and U S P 1,900,398, 1,922,872, 1,915,364
- BROOKS, B. T. *Ind Eng Chem* 16, 185 (1924) CF BURRELL, G. A., *Ind Eng Chem* 20, 602 (1928)
- BROWN, J. S. *Bull Amer Assoc Petr Geol* 16, 721 (1932)
- BRUCKNER, H. *Das Gas- und Wasserfach*, 442 (11 May 1929)
- BURRELL, G. A. *The Recovery of Gasoline from Natural Gas* (1925), and *Oil and Gas J* 27 (8), 168 (12 July 1928) CF GARNER, J. B., and MILLER, R. W., *Oil and Gas J* 26 (4), 137 (16 June 1927)
- CADMAN, W. H. *J I P T* 11, 487 (1925)
- *Ind Eng Chem* 26, 315 (1934)
- CHARLES, H. H., and PAGE, J. H. *Bull Amer Assoc Petr Geol* 13, 367 (1929)
- CLAPP, F. G. *Bull Amer Assoc Petr Geol* 8, 202 (1924)
- CLARKE, F. W. *The Data of Geochemistry* Bull 770, U S Geol Survey
- COTNER, V., and CRUM, H. E. *Bull Amer Assoc Petr Geol* 17, 877 (1933)
- CREMERS, M. *Ind Eng Chem* 16, 98 (1924)
- DROPS, ROY. Bull no 25, Kansas City Testing Laboratory (1931)
- DALY CONDOT, D. *Bull Amer Assoc Petr Geol* 18, 283 (1934)
- DEVINE, J. M., and WILHELM, C. J. U S Bur of Mines, Reports of Investigations no 3128 (Sept. 1931)
- DOBWIN, C. E. Cf reference no 58
- DUDLEY STAMP, L. *Bull Amer Assoc Petr Geol* 18, 315 (1934)
- DUNSTAN, A. E. *J I P T* 10, 54 (1924)
- *Scientific Foundations of Refining of Petroleum* Cantor Lectures, Roy Soc Arts (1928)
- Eleventh Ann. Report, Research Council of Alberta, 1930, Report no 26, 66 (Edmonton, 1931)
- ELWORTHY, R. T. Mines Branch, Dept of Mines, Canada, Report no 586, 1921, 56 (Ottawa, 1923)
- *Natural Gas in Alberta* Canadian Dept of Mines, Report no 616A, 1924
- *Helium in Canada* Canada Dept of Mines, Report no 679, 1926
- ERDELY, DR. A. Private communication
- ERKINE, A. M. *Ind Eng Chem* 18, 722 (1926)
- FULWELLER, W. H. *Proc 3rd Int Conf on Bit Coal*, 1931, 1, 165
- GARDESCU, I. I. *Bull Amer Assoc Petr Geol* 18, 871 (1934)
- GRAHAM, J. IVOR, and SHAW, A. *Trans Inst Min Eng* 73 (6), 529
- HASHIMOTO, K. *Trans Fuel Conf (World Power Conf)*, London, 1928, 1, 544 CF UWATOKO, K., *Bull Amer Assoc Petr Geol* 11, 187 (1927)
- HOPKINS, G. R., and BACKUS, H. *Natural Gas in 1931* U S Bur of Mines, 2, 24 (1933)
- HUME, G. S. *J I P T* 14, 669 (1928)
- JONES, G. W., YANT, W. P., and BURTON, E. P. U S Bur of Mines, Serial no 2553 (Dec 1923)
- KLING, K., and SUCHOWIAK, L. *Trans Fuel Conf (World Power Conf)*, London, 1928, 1, 821

- 37 LAKE, F W *Petr Eng Handbook*, 1st ed 162 (1930)
- 38 LINDSELY, B E U S Bur of Mines, Tech Paper 554
- 39 McLENNAN, J C British Science Guild Publicity Service Pamphlet no 1 (1923) Cf Mines Branch, Dept of Mines, Canada, Report no 322, 65
- 40 MACGRUDER, P S *Petr Eng Handbook*, 1st ed 296 (1930)
- 41 MARTIN, J W *Ind Eng Chem* 25, 256 (1931)
- 42 MILLER, J C *Oil and Gas J* 32 (25), 19 (9 Nov 1933)
- 43 MONTAIGNE BELL, H T *The Near East Year Book*, 1931-2
- 44 MOSS, K NEVILLE *Gases, Dust and Heat in Mines* (1927)
- 45 MOUREU J. C. S. 123, 1905 (1923)
- 46 NAMETKIN, S S, ZABRODINA, A S, KARKONAS, A S, KURSANOV, D N, SOKOLOV, V A, and USPENSKI, S P *Rept Govt Petr Research Inst Moscow*, 1932, 124-37
- 47 NASH, A W, and STANLEY, H M *Fuel*, 7, 397 (1928) Cf HATHFIELD, W D, SYMONS, G E, and MILLS, R R, *Ind Eng Chem* 20, 174 (1928), 18, 407 (1926)
- 48 ODELL, W W U S Bur of Mines Tech Paper no 483 Cf U S P 1,918,254
- 49 POWERS, S, and CLAPP, F G *Bull Amer Assoc Petr Geol* 16, 719 (1932)
- 50 ROSEWARNE, P V, CAMPBELL, W P, and OFFORD, R J Mines Branch, Dept of Mines, Canada, Report no 737 (1933)
- 51 SOKOLOV, V A *Neft Khoz* 18, 793 (1930) Cf MAXIMOV, N P, and AKIMOV, I N, *Neft Khoz* 20, 49 (1931)
- 52 STEFANESCU, N N *Oil Weekly* 73 (9), 165 (1934)
- 53 STILLE, H, and SCHLUTTER, H *Bull Amer Assoc Petr Geol* 18, 719 and 736 (1934) Cf GROTENSOHN, A., *Petr Z* 30 (5), 1 (9) (1934)
- 54 STRAHAN, A *Memoirs of Geol Survey, Special Reports on the Mineral Resources of Great Britain*, 7
- 55 THOM, W T *Proc 3rd Int Conf Bit Coal* 1931, 1, 84 Cf HARRER, R. B. *ibid* 194
- 56 TOBLIN, I, and ARAKELYAN, A *Neft Khoz* (1) 52 (1932)
- 57 TOLWINKI, K *Bull Amer Assoc Petr Geol* 18, 892 (1934)
- 58 *United States and other North American Gases Geology of Natural Gas Amer Assoc Petr. Geol* (1935)
- 59 WOOLNUGH, W G *Bull Amer Assoc Petr Geol* 18, 226 (1934)

Other References

- CHAHNAZAROFF, D Accumulation of Gas in Petroleum Formations *Proc World Petr Cong* 1, 294 (1933)
- PODBELNIAK *Analyses Ind Eng Chem Anal ed*, 3, 177 (1931), *Refiner*, 8, (5), 55 (1929)
- COMINS, D Gas Saturation Pressure of Crude under Reservoir Conditions *Proc World Petr Cong* 1, 458 (1933)
- STEWART, A *Helium* U S Bur of Mines, Inf Circ 6745 (Sept 1933) Cf RUEDEMANN, P and OLDS, L M, *Bull Amer Assoc Petr Geol* 13, 799 (1929)
- WASHBURN, E W Hydrocarbons in Petroleum *Ind Eng Chem* 25, 891 (1933)
- KANE, G P, KRISHNASWAMI, K R, and WATSON, H E *Indian Gases J Indian Inst Sci* 17A, 33 (1934)
- MEALS, S W *Natural Gas Industry Penn State Coll Bull* 12, 1933, 1
- BONDANOWICZ, C *Natural Gas in Russia Bull Amer Assoc Petr Geol* 18, 746 (1934)
- WILK, Z Nitrogen in Natural Gas *Przemysl Naft* 8, 343 (1933)
- OSTERMAYER, J B Radioactivity Measurements for locating Natural Gas *Proc World Petr Cong* 1, 121 (1933)
- BIRSWALD, W B, and JOHNSON, T W Viscosity of Natural Gas U S Bur Mines, Tech Paper no 555
- HAMMERSCHEIDT, E G *Ind Eng Chem* 26, 851 (1934)
- SOUTHWELL, C A P, and MAY, C J *J I P T* 20, 537 (1934)
- BEALL, I N *Refiner*, 15, 264, 407 (1936)
- STOCKMAN, L P *Oil and Gas J* 35 (18), 48 (1936)
- DUNSTAN, A E, and HOWES, D A *J I P T* 22, 347 (1936)
- McMILLAN, W A *J I P T* 22, 616 (1936)

HELIUM

By Professor F. A. PANETH, Ph.D.

Imperial College of Science and Technology, London

I. Properties, Radioactive Formation, and Analytical Detection of Helium

HELIUM is the second element in the Natural System and the lightest of the rare gases. The weight of 1 litre of helium (N.T.P.) is 0.1785 g., its specific gravity is 0.138 as compared with 1 for air. Its atomic weight is 4.002, but in all probability there exists another kind of helium atom of mass 3.016 formed by certain processes of artificial transmutation [46, 1934]. It has not yet been possible to detect this helium of atomic weight 3 in nature, nor could the reports [23, 1934] on its production in quantity be confirmed [51, 1935].

Helium diffuses generally about 3 times as quickly as nitrogen ($\frac{1}{3}$ as quickly as hydrogen), but there are certain materials, for instance vitreous silica, ordinary glass at higher temperatures, and gelatine, celluloid, and cellophane [56, 1936], which are practically airtight but nevertheless possess an abnormally high permeability for helium.

Being a rare gas, helium has not the faculty of forming stable chemical compounds, those reported by various investigators [4, 1925, 40, 1927, 44, 1927] have not been confirmed [37, 1925, 50, 1928]. For the same reason it has neither taste nor smell. Its optical spectrum is very characteristic, especially the prominent yellow line 5875.63 Å., which is essentially responsible for the colour of rarefied helium under the influence of electric discharges. Other lines in the visible part of the spectrum which can also be easily observed have the wave-lengths 6678.15, 5015.68, 4921.93, 4713.15, and 4471.48 Å.

The thermal conductivity of helium is approximately 6 times that of air. Its solubility in water is only 0.97 vol. in 100 vol. water at 0° (nitrogen 2.35, oxygen 4.89 vol.).

Helium is the most difficult of all gases to liquefy, its critical temperature is -267.9°C (5.2°K). Its boiling-point under atmospheric pressure is -268.9°C (4.2°K). The density of liquid helium depends on both temperature and pressure, at a temperature of 4.2°K and a pressure of 1 atm its density is 0.125 or $\frac{1}{8}$ that of water. At low temperatures and high pressures it is possible to obtain helium also in the solid state.

Helium is produced in the course of many natural and artificial atomic transmutations. The α -rays of radioactive substances like uranium, radium, radon, or polonium consist of positively charged helium atoms. In the successive stages of the transmutation of a uranium atom into lead 8 helium atoms are liberated, in the transmutation of a thorium atom into lead, 5 helium atoms. Consequently, in the course of geological times a certain amount of helium is produced in all minerals and rocks containing uranium or thorium, 1 g. of uranium develops 1.16×10^{-7} c.c. helium per year, 1 g. thorium 2.43×10^{-6} c.c. Whether the whole amount of helium remains occluded or not depends upon the hardness of the minerals (or rocks) and upon the temperatures to which they have been subjected after their solidification; the escape of helium is greatly facilitated by the presence of hydrogen [12, 1934, 50, 1928]. The feeble radioactive rocks generally retain their helium content better than minerals rich in uranium or thorium [16, 1929;

25, 1936, 32, 1935]. This may be due to the smaller gas pressure in ordinary rocks the helium content never exceeds the order of 10^{-4} c.c. per g., while a radioactive mineral, as, for instance, thornamite, contains up to 9 c.c. per g.

As instances of artificial processes of atomic disintegration by which helium is produced we may quote the bombardment of lithium by hydrogen [14, 1932] according to the equation $\frac{1}{2}\text{Li} + \frac{1}{1}\text{H} = 2\frac{1}{2}\text{He}$ or the impact of neutrons on boron [1, 1935, 9, 1935, 48, 1936] $\frac{10}{5}\text{B} + \frac{1}{0}\text{n} \rightarrow \frac{4}{2}\text{He} + \frac{3}{1}\text{Li}$. It is possible that in nature, besides the radioactive disintegration processes, other elementary transformations similar to those artificially produced take place, and that such a formation is responsible for the occurrence of helium in beryllium minerals [22, 1934] or perhaps even in natural gases.

Thanks to its characteristic spectrum and the ease of its separation from other elements, the methods for the detection of helium are extremely sensitive, a fact which simplifies the study of its distribution in nature. The limit of the qualitative detection of helium is at present about 10^{-9} c.c. [49, 1928]. For the determination of quantities of the order of 10^{-8} to 10^{-9} c.c. the method of Prani is especially suitable, it is based on the conductivity of helium for heat [52, 1931].

II. Occurrence of Helium

Like the other rare gases, helium is a constituent of the atmosphere. Its quantity near the surface of the earth amounts to 5.3×10^{-6} c.c. per c.c. of air. For theoretical reasons it is probable that in the stratosphere its relative proportion is increased, and it has been reported [34, 1935] that its ratio is already higher at altitudes between 9 and 17 km., but with a more accurate method even at a height of 18 km. no difference has been found. One air sample from 21 km. height contained 5.64×10^{-6} c.c. (N.T.P.) per c.c. of air [47, 1937], i.e. a surplus of 7%.

Unlike the other rare gases, helium occurs not only in the atmosphere but, as a product of radioactive disintegration, in all minerals and rocks containing uranium or thorium (see part I). It has been estimated that between 8 and 30 million cu. m. of helium are generated annually by radioactive processes [57, 1921]. As mentioned before, a fraction of the helium content of the earth's crust constantly escapes and accordingly a current of helium rises from the earth into the air, it is probable that this current enriches the atmosphere every year by several million cubic metres of helium [42, 1923, 54, 1928]. As the helium in the whole atmosphere may be taken to be about 10^{14} cu. m., an amount equal to the present helium content would be added every 10 million years or so. Since this is only a small fraction of the time the atmosphere must be assumed to have existed, the conclusion is unavoidable that the helium, owing to its lightness, is not permanently retained by the gravitational field of the earth but escapes into the void. It is not yet known whether a dynamic equilibrium between the two processes has been reached and whether, therefore, the helium content of the atmosphere is constant.

There are several places on the earth where the escape

of helium, together with other gases, is especially marked. Here the quantities of helium which leave the earth's crust are so considerable that they cannot have been freshly formed from rocks by radioactive processes, they consist of 'fossil' helium which has been collected during geological periods and has only recently found an opportunity to escape. It follows that these helium discharges are not constant, but are bound to decrease and come to an end after a definite period.

Such high concentrations of helium have been observed especially in three groups of natural gases [69, 1934, 72, 1923] gases from mineral wells, volcanic gases, and gases from petroleum fields. Each of these may, however, occur also practically free from helium and so far one has not succeeded in establishing a connexion between the chemical composition of natural gases and their helium content. Most of the helium-bearing gases from mineral wells in France, Italy, Germany, and Japan consist almost exclusively of nitrogen, some of French origin contain also carbon dioxide in considerable quantity. This latter gas is the main constituent (up to 99%) in the 'Soffioni' in Italy and in similar volcanic gases in Japan. The gases from petroleum fields consist in most cases mainly of combustible hydrocarbons, but there are exceptions with a high percentage of nitrogen or of carbon dioxide, in these gases much nitrogen is an indication of the presence of helium [57, 1921], there is, however, no proportionality between helium and nitrogen content. Very similar in composition are the gases in coal-mines, in particular those of French, German, and Japanese origin have been analysed. It may be mentioned that the gases occluded in coal contain also traces of helium [19, 1932, 64, 1933].

The lack of any close relationship between the chemical composition of the gases from petroleum fields and their helium content is clearly shown by Table I, in which a few important cases are selected from the large number of published analyses. It can be seen that some gases especially rich in helium contain up to 85% of nitrogen. On the other hand, natural gases with more than 90% nitrogen may contain any helium amount between zero and 10%, and volcanic gases, mainly composed of carbon dioxide, may be almost free from nitrogen, while containing at the same time a considerable amount of helium. Neither is the geological occurrence of a gas sufficient to predict, with our present knowledge, whether it contains any appreciable amount of helium, the only means of deciding this question is a direct helium analysis.

To ensure a promising industrial exploitation a high percentage of helium is, of course, not sufficient, in addition the total output must be very large. The four producing gas-wells of the Cliffsfield (Potter County, Tex.), the site of the Amarillo plant, have a total initial open-flow of 30,000,000 cu ft. per day [62, 1934]. Where the absolute yield is so small, as, for example, in the thermal wells in France containing a helium percentage up to 10, no practical use can be made of the helium. Extensive surveys in France [45, 1915-16], Germany [21, 1934], Italy [35, 1932], Poland [28, 1927], Roumania [8, 1926-7], New Zealand [58, 1930], and Japan [26, 1926] make it highly improbable that there will ever be found helium occurrences of any practical value. So far no official report has been published about the result of the survey carried out for many years in the vast area of U.S.S.R. Even the Canadian fields (mainly in the provinces of Ontario and Alberta) [17, 1926, 39, 1920, 59, 1932] cannot compete with those in U.S.A., where helium content, volume of the gas, and the topographical and geographical situation combine so favourably that a helium production on a commercial scale could be established.

Gases containing more than 1%—which is generally considered as the lower limit for economical extraction [62, 1934]—are uncommon even in U.S.A. and restricted chiefly to the Mid-Continent region and to smaller areas in Colorado and Utah [57, 1921, 70, 1935], the main Mid-Continent helium fields are situated in the states of Texas, Oklahoma, Kansas, Missouri, Tennessee, Ohio, and Pennsylvania. The most important of the U.S.A. fields are the property of the Government. While the Cliffsfield (Potter County, Tex.) is exclusively used at present for drawing all the helium necessary for the Government, other fields are retained where the helium is stored in its natural reservoir underground [62, 1934]. This is the case in the 'Helium Reserves' I (Woodside, Utah) and II (Grand County, Utah), gas from the first contains 1.3%, from the latter about 8% helium. A few rich fields at Dexter, Kans., and Thatcher, Colo., belong to private companies which since October 1927 intermittently have produced helium for sale, the raw gas at the Thatcher, Colorado, Plant contains also 8% helium [38, 1929].

III. Origin of Helium in Natural Gases

It has been pointed out in part II that the larger quantities of helium evolved in natural gases are no doubt 'fossil'. A simple calculation [10, 1934] shows that the

TABLE I
Analyses of Natural Gases from Wells in the United States and Canada [15, 1935]
(Percentage)

State or province	Field or district	Depth in feet to gas horizon	CH ₄	C ₂ H ₆	CO ₂	O ₂	N ₂	He
<i>United States</i>								
Colorado	Model Dome	909	0.00	0.00	12.19	0.92	79.71	7.18
Kansas	Augusta	500	10.54	1.64	0.13	0.00	85.56	2.13
Kansas	Augusta	1,440	79.10	7.44	0.00	0.00	12.44	0.25
Kansas	Dexter	310	14.85	0.41	0.00	0.20	82.70	1.84
Texas	Cliffsfield	3,200	59.80	13.70	0.70	0.10	23.90	1.80
Texas	Petrolia	1,600	51.30	10.40	0.10	0.00	37.20	1.00
Utah	Woodside	3,120	0.00	5.70	31.70	0.27	62.33	1.31
Utah	Harley	860	5.10	2.30	1.10	0.00	84.40	7.16
<i>Canada</i>								
Alberta	Row Island	1,900	89.55	1.90	0.10	0.21	7.91	0.33
Ontario	Woodhouse Tp	1,150	87.60	4.90	0.10	0.40	7.62	0.38

uranium and thorium content of ordinary rocks, even in a limited area, is high enough to produce in geological times all the helium in the richest helium-containing wells. It seems certain, therefore, that important helium occurrences in Texas are ultimately due to the uranium and thorium content of underlying volcanic rocks (Pegmatites and Granites), and that the helium content of gases in the Tuscan Maremmae and French springs can also be traced to volcanic rocks below, on the other hand, for large helium occurrences in Kansas the helium production of sedimentary layers may be responsible [57, 1921, 60, 1929]. It is true that G. Sh. Rogers [57, 1921] doubted whether the natural radioactivity of the basic layers was high enough, and was inclined to attribute the origin of helium in the petroleum fields to an unknown radioactive process, while Lepape [33, 1933], more definitely, suspected hypothetical cka-cesium as the helium source, but at present there does not seem to be any reason to consider the uranium and thorium content of rocks as inadequate, if sufficient time for helium formation be given. As would be expected, gases originating in older geological layers contain more helium than those from tertiary formations [3, 1935, 27, 1932, 57, 1921, 72, 1923].

The helium gas, produced by radioactive disintegration in rocks, may be so tightly held that only an insignificant fraction escapes during hundreds of millions of years, this is proved by the possibility of basing a geological age-determination on the helium content of rocks even of archaic type [32, 1935]. But in other cases more than 99% of the helium accumulated in old rocks was released in consequence of being exposed for some time to higher temperatures [25, 1936]. If similar conditions prevail today, such a tapping of a 'primary' helium deposit may fully account for the helium content of gases in thermal springs, which sometimes amounts to as much as 10% where the whole yield of gas is nevertheless of small volume. On the contrary, all the industrially important helium-wells discharge such enormous quantities of helium that the supposition of some 'secondary' deposits where the helium gas has been stored seems inevitable [3, 1935].

It is obvious that for the formation of such secondary helium reservoirs three different conditions are essential: the helium must have been (1) generated in radioactive rocks, (2) released from these rocks, and (3) caught in a reservoir. The small probability of all three conditions being fulfilled is very likely the reason why so comparatively few large helium-wells exist. Granitic rocks with their high uranium and thorium content are frequent enough, but geological factors favouring helium release (high temperatures, disintegration of the rocks) are, in general, unfavourable for its collection, the helium will in most cases escape into the atmosphere. If, e.g., the structure of the earth's crust is as broken as in western Europe, the accumulation of large quantities of helium in gas-tight reservoirs seems impossible [3, 1935], and since specially suitable domes, or anticlinal folds, with an impervious cap-rock are obviously necessary for helium storage, it is hardly astonishing that even slight local structural variations may cause wide differences in the helium content of gas-wells, that, e.g., the helium in the Bush Dome (Amarillo field, Texas) gases amounts to as much as 2% while it is much less in the larger neighbouring dome seems hardly explicable except by accidental geological changes [60, 1929] which baffle any general treatment.

The primary importance of rock quality seems to be borne out by the fact that the gases in the Iran and Iraq oil-

fields apparently do not contain any appreciable amount of helium, two analyses of Iranian gases showed only 2.4 and $2.7 \times 10^{-3}\%$ helium, and a gas sample from the Kirkuk oil-field as little as $2.1 \times 10^{-4}\%$ [20]. Such low values are hardly ever found in any of the American gases from petroleum fields which, on the contrary, not infrequently contain several per cent of helium. Now the most obvious difference between the stratigraphy of Southern Iran and Iraq and that of the American helium-rich regions is the absence in the former of any granite mass closely underlying the oil- and gas-bearing strata as in West Texas and Kansas [71]. The succession of strata in Iran from the Miocene beds (in which the oil is found) down to the Cambrian, is some 20,000 ft. thick, and is dominantly composed of carbonate rocks (dolomite, limestone, and marl), whereas in most American oilfield regions, even where no granite floor lies immediately below the oil-bearing strata, the stratigraphic column shows a high proportion of quartz-sandstone, a material which must have been produced at some time or other by the disintegration of granites or granitoid rocks [71]. Since it is well known that granites are the rocks richest in uranium and thorium, while carbonates are very poor, this would seem to be direct evidence for the importance of the nature of underlying rocks, however, a larger survey of the helium content of gases from Iran and Iraq wells is certainly desirable.

As for the second condition mentioned above, i.e. helium release, we know from laboratory experiments that the escape of helium is very much accelerated by grinding as well as by heating the rocks. We should therefore expect that destruction of the original granite would have a similar effect, in this connexion it is interesting to note that the helium-wells of Amarillo (Texas) are separated from ancient granitic rocks by a layer of coarse arkose grit which has a much larger surface from which helium can escape than granite [3, 1935]. With regard to the temperature, it is very likely that very moderate heating (to less than 100°C) may have a large effect, as laboratory experiments shown that at 200°C the helium loss is appreciable in a few hours [25, 1936], obviously much lower temperature must suffice to drive out most of the helium if the time be not measured by hours but by thousands or millions of years.

Finally, in connexion with the third condition, the trapping of the released helium, there exists a regularity which no radiologist or geologist is likely to have expected *a priori*: the only commercially important helium-wells are found in petroleum fields. For this fact some reason has to be given.

Some geologists are satisfied with the explanation that helium is produced in similar quantities by rocks in many other places of the earth, but that generally it escapes into the atmosphere through cracks and fissures in the soil and therefore cannot accumulate during geological times; in their opinion the liquid layer of petrol forms a kind of trap for the gas. It would be expected, however, that the helium would be richest in the deepest oil deposits which are nearest to the radioactive rocks, while, in fact, as a rule the shallow wells contain more helium [57, 1921]. Recently there has been advanced another hypothesis linking the helium occurrence with the presence of petroleum. It is well known that minerals release their helium content more easily in the presence of hydrogen [12, 1934, 50, 1928]. Chlopin [10, 1934, 11, 1934] thinks that hydrogen, which is of very rare occurrence in nature, may be produced by disintegration of the hydrocarbons present in oil and so

facilitate the liberation of helium from rocks underlying the oilfields. There is some difficulty in the assumption that the influence of hydrogen leads to the storage of helium in such quantities, as the temperatures necessary for the thermal decomposition of hydrocarbons are much higher than can in general be assumed for the rocks under the oilfields [3, 1935].

In recent years the remarkable fact has been established in Russia [13, 1932, 66, 1930], Czechoslovakia [2, 1935], and Germany [5, 1936] that the waters which lie below petroleum possess a much higher percentage of radium than those from any other locality. While the normal radium content of surface-waters and of sea-waters is of the order of 10^{-14} g per c c, and even the so-called 'radioactive' springs generally contain not more than 10^{-14} g of the long-living radium per c c, and owe their high radioactivity to the quickly decaying radon, these brines under petroleum have been found to contain radium up to concentrations of 10^{-10} g per c c. It is more than probable that the high radium content is closely connected with the fact that these waters are poor in sulphates, for it is known that, owing to the extremely low solubility of radium sulphate, only water containing no more than 0.2% of sulphates can dissolve radium. The absence of sulphates in the water underlying petroleum has apparently enabled it to extract radium from the rocks, 1% of the radium content of volcanic rocks brought into solution can account for the radium content of the richest waters [29, 1933, 30, 1932, 55, 1929, 1932]. As radon is easily soluble in petroleum and by its decay there produces helium, it is possible that the radium content of the waters plays a role in the accumulation of helium in the oil.

It has been pointed out, too, that in some regions with rich helium-wells the granite is closely associated with the radioactive mineral carnotite, it is therefore possible that the formation of such radioactive minerals in certain places acts in similar fashion as an intermediary in the process of forming helium reservoirs [57, 1921], but so far no calculation has shown that their influence is of quantitative importance.

Finally, a few theories must be mentioned which have attempted genetically to link the production of helium with that of petroleum. Lind [36, 1931] has pointed out that the α -rays of radioactive substances (which in any theory must be postulated as the ultimate source of helium) may by their impact on a few members of the methane series convert them into a very complex mixture of higher hydrocarbons, and finally into petroleum. M. N. Rogers [18, 1928, 58, 1930] supported this theory by showing that the relative quantities of the helium and petroleum are of the order to be expected. However, this theory, in its original form, neglected the origin of petroleum from micro-organisms (which for many reasons seems to be beyond doubt), and found it difficult to account for the absence of hydrogen—a necessary by-product in the reaction considered by Lind. A somewhat different theory deserves, therefore, perhaps more consideration. It has been established [7, 1927, 68, 1933] that some micro-organisms are able to concentrate radium and mesothorium (possibly also uranium and thorium), and some scientists think that the α -rays of these radioactive substances and of their disintegration products have helped to transform the body of the micro-organisms into petroleum, while they themselves finally gave helium gas. Such theories have been backed by Salomon Calvi [61, 1931] and Vernadsky [67, 1935], but here, too, any quantitative proof is still missing. It deserves

to be specially emphasized that there is no connexion between the amount of hydrocarbons and helium; for instance, the field at Thatcher, one of the richest in helium and at the same time producing a very large amount of gases, contains only 2% of hydrocarbons [38, 1929]. The importance of a high nitrogen content is much more strongly indicated by the analyses (see part II), in agreement with this is the fact that in none of the Iranian wells whose low helium content has been mentioned above [20] has as much as 1% of nitrogen been found [71], but so far not a single plausible theory has been put forward to account for this parallelism.

At present it does not seem very likely that the last-mentioned theories will supersede the main explanation for the presence of helium in petroleum fields, i.e. the escape of helium from underlying radioactive rocks and its trapping in domes, although in some places they may contribute to a deeper understanding of the mechanism of this process.

IV. Extraction and Purification of Helium

In parts I and II details have been given about the presence of helium in the atmosphere, in rocks and minerals, and in gas-wells. From all these three sources helium can be prepared.

(a) Helium from the Atmosphere.

Liquefaction of the gases of the atmosphere and fractional distillation makes it possible to separate every constituent. A description of this procedure is outside the scope of the present article. Many of the plants for the preparation of oxygen from air are in a position to supply helium also, an especially efficient procedure has been worked out by Meissner [41, 1932].

This source of helium is, of course, available in every country, but the price of the final product is high, a British firm, for example, supplies helium from atmospheric air at 27s 6d per litre.

(b) Helium from Radioactive Minerals.

Whenever the solid constituents of radioactive minerals are extracted the helium is driven out, it is in general not too difficult to conduct the process in such a way as to permit collection of the helium. Since 1 kg of thorite (an oxide of thorium and uranium) contains about 9 litres of helium, and 1 kg of monazite (a cerium phosphide, with thorium) about 1 litre, this source of the rare gas is a very convenient one for laboratory preparation of small quantities. Where large amounts of the raw material are available the process may be conducted even on a commercial scale [53, 1925, 65, 1929]. This method for the production of helium is, of course, limited in scope, and much more expensive than the exploitation of gas-wells. A firm in Berlin has for many years supplied helium of 85% purity, produced from monazite sands, at a price of 4.50 Marks per litre.

(c) Helium from Natural Gas.

The only gas-wells permanently used for helium production are in the petroleum fields in U.S.A. In Italy an attempt has been made since the war to make use of the Maremma of Tuscany, they are valuable for the heat they produce, and it has been shown that their helium can be collected. No permanent plant, however, has been established [14a, 1933], for some of the American wells yield helium in such large quantities that not only the Italian plant with its very poor raw material (about 0.1% helium)

but even the experimental plants built in the Canadian oil region which could be operated on fairly rich gas-wells (0.3 to 1.0% He) have been brought to a standstill. In U S A the first plants were erected at Petrolia and at Fort Worth (Tex.), but these, too, have now been abandoned, and the only one still working is in Amarillo (Tex.) [64, 1933] which is run under such favourable conditions that the cost of helium is lower than anywhere else.

The production of helium at the Amarillo plant is treated in the article by R. R. Bottoms (p. 1517).

The price of helium from gas-wells depends mainly on the costs of production. The Amarillo plant was able to reduce it to \$11.61 per 1,000 cu ft of 98% purity, and allowing for returns from the sale of the residue gas, the net cost of operation amounted only to \$8.60 per 1,000 cu ft of helium produced. A private plant, the Helium Co (Louisville), during the years 1927-30 was able to supply helium at about \$34 per 1,000 cu ft.

For the past few years helium production of non-Government plants in U S A was of the order of 1,000,000 cu ft per year [62, 1934-5], but operations have now apparently completely stopped, this helium was mainly used in small, privately owned dinghies. The Amarillo plant produced, in the six years prior to the end of 1934, more than 60,000,000 cu ft, i. e. an average of more than 10,000,000 cu ft per year. This output could, if necessary, be increased at least 3 times.

V. Uses of Helium

Small quantities of helium are frequently wanted in scientific laboratories for various physical or chemical operations. On account of its inertness and high heat conductivity it is valuable for cooling electric motors and fireproofing high-tension switchboxes, and for chemical reactions requiring to be studied in a gaseous medium which does not participate in the reaction. In the cathodic sputtering of beryllium and aluminum or in the purification of metals in the molten state helium can afford protection against oxidation [31, 1932]. Glossy metal parts can be annealed in an atmosphere of helium. Its high conducting power for heat renders it useful as a circulating medium in heating and cooling plants. It is also used for the filling of radio valves, gas-thermometers, and, sometimes, toy balloons, and can be applied as a drying agent in cases where the application of a vacuum would reduce the temperature too much and thereby slow down the process [63, 1930].

Helium is absolutely indispensable for the attainment of very low temperatures, here the liquefaction of helium is always a necessary step.

For all these purposes comparatively small quantities of helium suffice. Larger amounts are required by the electric-sign industry, helium-filled electric discharge tubes emit a pale yellow light. In Deep-sea diving and Casson work an artificial helium-oxygen atmosphere offers advantages [24, 1927]: because helium is less soluble than nitrogen in the blood and escapes more quickly and in smaller bubbles as soon as the pressure is released, the so-called Casson illness can be avoided, and the decompression period shortened. It is not improbable that in future the foodstuff industry, too, will demand larger quantities of helium [38, 1929], since it has been proved that the fermentation processes in fruit juices, cakes, and so on can be suppressed by a helium atmosphere as well as by the more expensive application of a refrigerator.

By far the largest demands on the capacity of helium

plants have been made by aeronautics. Its employment in floating balloons and airships recommends itself strongly, as the lifting power of helium is more than 92% of that of hydrogen, over which it has the great advantage of being non-inflammable, this diminishes the danger of accidents and in times of war renders an airship much less vulnerable. This use of helium will now be considered here in some detail, as 'the future of lighter-than-air craft will determine the future of helium production' [62, 1934]. Only helium-filled airships need be considered here, since the occasional inflating of big balloons, e. g. in 1935 of the stratosphere balloon Explorer II which consumed 250,000 cu ft of helium, is too rare an event to influence the helium demand.

The idea of filling airships with helium instead of hydrogen was first seriously discussed when during the war a German Zeppelin flying over England seemed fireproof and was therefore supposed, albeit erroneously, to be filled with a non-inflammable gas [43, 1926]. The English navy tried to imitate this by using helium, and in Canada, and later in U S A, plants were erected for its preparation on a large scale. This industry was ready just at the end of the war, and then many countries desired to possess airships filled with helium. This accounts for the very intensive search for helium-rich gas-wells during the post-war years, success was, however, everywhere disappointing, with the one exception of U S A. Since, e. g., at least 6 million cu ft. of helium are required to fill an airship of the size of the *Hindenburg*, all the helium-containing wells of Germany together could only provide the necessary quantity in about 1000 years. Even in Canada, with her immensely richer supply, not more than about 60,000 cu ft of helium were produced during the whole trial runs from 1919 to 1920.

The U S A is at present the only country where practically unlimited quantities of helium can be obtained. From the figures given in part IV it appears that for the U S A Government helium is available at such a low price that the first filling of an airship with this gas is little more expensive than a hydrogen filling. And as hydrogen, once contaminated, must be thrown away, while helium can be very cheaply purified and used again [63, 1930, 64, 1933], it actually costs less to operate an airship with helium, the reduced risk of an explosion will, in addition, lower the rates for insurance of any commercial airship [6, 1929].

It is doubtful, however, whether full use will ever be made of the possibilities in U S A of preparing millions of cubic metres of helium, for during recent years all countries except Germany seem to have lost interest in the construction of large airships. The main reason is that it became clear that a helium filling ensures no guarantee against catastrophes. It is certain that the extent of the disaster of the English airship 'R 101' would have been less had it been filled with helium instead of hydrogen, but a number of American airships have perished in spite of their using helium, while, on the other hand, the German airship *Graf Zeppelin* has managed to travel on hydrogen for more than one million kilometres without any major accident, its journeys including a trip round the world and more than a hundred crossings of the Atlantic. As Germany possesses no helium supply of her own (see part II), hydrogen was again adopted as a filling gas for the ill-fated airship *Hindenburg*. There had been plans to diminish the inflammability by inflating all its outer cells with helium, this was to be done after its first crossing to U S A and would have involved only a fraction of the total gas volume; but it seems that even this limited usage of helium was later thought to be unnecessary. So the present situa-

OCCURRENCE AND PRODUCTION OF HELIUM IN THE UNITED STATES

By R. R. BOTTOMS

Director of Research, The Girdler Corporation

HELIUM belongs to the group of rare gases of the atmosphere, which group comprises, besides helium, neon, argon, krypton, xenon, and radon. All these elements are monatomic gases, and are characterized by their chemical inertness and, with the exception of helium and argon, by their comparative rarity.

Helium was isolated from the gases evolved from the mineral cleveite and identified as a terrestrial element by Sir William Ramsay in 1895 [6]. Later researches have shown that helium is a very widely distributed element, that it is a constituent in small amounts of gases from mineral springs, of volcanic gases, occurs in minute quantities in river-water and sea-water, occurs in traces in nearly all rocks and minerals, and that it constitutes 1 part in 185,000 parts of atmospheric air. It has also been shown that helium is a variable constituent in nearly all natural gases [3, 1907, 4, 1926, 5, 1911, 7, 1921, 8, 1912].

In 1906 Cady and McFarland [3] of the University of Kansas investigated a peculiar non-combustible gas from the town of Dexter in Kansas, and found helium to the extent of 1.84%. This discovery led to the examination of other gases from the same locality, and also gases from other points in Kansas, and helium was found to be a constituent of all of them. These investigations have been greatly extended by Cady and his students, and also by others since these discoveries, and to-day the testing of natural gas for its helium content is a regular procedure the world over.

Helium occurs in natural gases in the United States in commercial quantities in widely separated areas. Helium has been found in natural gases in Canada, in Japan, and it has been reported that helium occurs in commercial quantities in U.S.S.R., however, this latter has not been confirmed. It has been reported recently [1, 1935] that a flow of natural gas encountered on the east coast of Sweden on Öland Island analysed 1.4% helium. In Canada there are two gasfields with helium-bearing gases just bordering on what might be considered commercial quantities. One of these gasfields is located near Calgary in Alberta a few miles north of the Montana line, and a field in Ontario north of Lake Erie. In the United States helium occurs to some extent in most natural-gas deposits. However, there are some gas deposits occurring on the Pacific Coast and on the Gulf Coast of Louisiana which show no helium that can be detected by the usual analytical methods. Natural gases from different fields and even from different geological strata in the same field may vary widely in chemical constitution and helium content. A few typical analyses are given in Table I. This table, however, represents only a very few of the analyses that have been made of the natural gases of the United States, but will serve to give an idea of the helium content in various localities.

The accompanying map (Fig. 1) shows the location of the principal helium-bearing areas in the United States. Commercial deposits of helium, however, are found in only 9 of the 48 States. The helium-bearing gas areas of the United States, all but 1 of which lie west of the Mississippi

River, have been divided into 5 geological provinces. This has been done because the general geological features affecting the origin of the structures, and probably the origin of the gases, are similar throughout the individual provinces. The provinces and the area embraced by each province are as follows:

- 1 Central Province, comprising central and western Kansas, Oklahoma, and north central Texas
- 2 Eastern Rocky Mountain Province, comprising south-eastern Colorado, north-eastern New Mexico, and the Texas and Oklahoma panhandles
- 3 Western Rocky Mountain Province, comprising south-western Wyoming, eastern Utah, north-eastern Arizona, north-western New Mexico, and western Colorado
- 4 Northern Province, comprising north central Montana and southern Alberta
- 5 Eastern Province, comprising southern Michigan, southern Ontario, western New York, and eastern Ohio

The central helium province includes all of Kansas east of the 99th meridian, all of Oklahoma except the panhandle, and the extreme northern tier of counties in Texas except the panhandle.

Several areas in south central and central Kansas have developed helium-bearing gas. One area in north central Texas also is productive of helium-bearing gas. In the Central Province the rocks which are productive of helium-bearing gas range from Ordovician to Permian.

The three most important helium-bearing gas areas of the Central Province are those located at Dexter in Cowley County, Kansas, Bison in Rush County, Kansas, and at Nocona in northern Texas and southern Oklahoma. In the Dexter area a structure which gives rise to the helium-bearing gas is a north-south narrow anticline. Oil and helium-bearing gas have been produced on the Dexter anticline for a number of years, and a large number of wells have been drilled. The wells have initial productions ranging from 1 to 7 million cu ft of gas per day, and a rock pressure of 260 lb. A plant for the commercial production of helium has been built at Dexter, utilizing the gases from this area for the production of helium, and has been in operation since 1927. The estimated quantity of helium available from the Dexter anticline is approximately 172 million cu ft. Other producing areas within piping distance of Dexter have been estimated to contain recoverable helium of the amount of about 150 million cu ft.

The Bison area is located in Rush County, Kansas, near the town of Bison. Since there have been few wells drilled on this structure, little is known of the total probable producing area of this pool. The estimate of helium reserves in this pool, deduced from the meagre information obtainable, is about 54 million cu ft. The helium reserves in the Nocona area have been estimated to be approximately 320 million cu ft.

NATURAL AND REFINERY GASES

TABLE I
Typical Analyses of Natural Gas

State	County	Analyses						Ratio N ₂ He		
		O ₂	CO ₂	CH ₄	C ₂ H ₆	N ₂	He			
1	Arkansas		Union	4.79	71	20	0.04	900		
2			Ousehilla	0.50	93.0	4.49	0.01	500		
1	California	2.85	Takama	0.59	66.3	30.20	trace			
4		1.40	K ngs	0.90	79.9	17.70	0.10	177		
5			Los Angeles	0.30	99.5	0.45	0.02	22.50		
6	Colorado	2.28	Huerfano	1.68	37.20	53.90	4.90	0.04		
7		1.93	Las Animas	14.68	none	74.75	7.65	8.65		
8		0.31		7.12	11.87	71.44	9.26	7.75		
9			Yuma	0.21	85.80	10.30	3.62	52.00		
10			Larimer	0.30	0.35	75.00	24.00	0.13	0.02	17.00
11		1.16	Weld	0.29	0.00	0.00	98.55	0.01	9.855	
12			Las Animas	14.70	0.00	0.00	77.60	7.70	10	
13		0.58	Moffatt	1.06	42.60	0.99	55.41	0.05	923	
14	Idah	0.50	Payette	0.43	80	bal	0.00			
15	Illinois		Crawford	1.34	16.00	68.85	3.70	0.11	36	
16	Kansas		Cowley	trace	0.18	15.30	8.28	74.26	37.50	
17				0.016	none	99.00	0.005	100.000	0.005	
18		0.49	Rush	0.05	68.75	5.25	23.91	1.52	15.50	
19		8.00	Newton	1.75	1.8	87.40	1.01	87		
20			R ce							
21		0.31	Summer	0	56.00	16.00	bal	0.73	40	
22			Waburness	0.02				1.60		
23			Sedgewick					1.14		
24		0.30	Elk	0.62	68.65	10.42	19.31	0.70	28	
25		0.11	Reno	0.31	38.84	12.95	46.75	1.04	46	
26			McPherson	12.41	16.40	21.80	46.00	0.13		
27		0.80	Stevens	0.80	0.19	71	0.00	23.64	60	
28		0.77	Harvey	0.40	58.64	11.00	28.75	0.74	40	
29		0.24	Edwards	0.00	61.50	9.40	28.78	0.68	360	
30			Chase					0.95		
31			Chataqua					1.28		
32			Elk	0.25		26	70+	3.40	20	
33			Greenwood	0.00		64	35	1.38	25	
34			McPherson	0.00		41	56.65	2.45	23	
35			Russell	0.04		45.6	bal	1.64		
36	Kentucky			0.61		98.4	0.63	0.36		
37			Jefferson					0.55		
38	Louisiana	0.15	Richland	0.0	60.80	21.20	17.76	0.09	0.01	
39			Caldo					0.03		
40			De Soto					0.00		
41	Michigan	0.50	Isabella	0.11	62.00	9.90	6.2	0.96		
42		0.31		0.00	32.10	25.50	14.30	2.00	7.00	
43			Muskegon	0.40			14.00	0.24	56	
44		1.70	Sillwater	1.10		96.98	0	0.22		
45	Massesppi	0.45	Hinds	0.34	19.00	0	0.21	0.001		
46	Montana		Toole	45.00	0.00	5.80	48.40	1.12	210	
47			Petroleum	0.36	23.00	19.60	bal	1.50		
48			Muscellah				54	16.00	3.40	
49		0.44	Carbon	1.28	50.24	38.60	bal	0.03		
50	New Mexico	0.30	Eddy	0	28.95	3.84	68.67	0.04		
51		9.67		49.70	none		bal	1.99		
52			Mora	97.29	0.07	0.10	bal	trace		
53	New York		Allegany	0.00	98.00	1.50		0.50		
54	Ohio		Vinton	0.00	57.50	11.76	30.00	0.50	60	
55	Oklahoma	0.19	Alfalfa	0.00	0.00	0.00	99+	0.72	141	
56			Forker					0.56		
57			Jefferson	0.33	53.20	9.00	bal	0.97		
58			Texas	1.71	0.21	78.00	19.71	0.36		
59	Pennsylvania							0.37		
60			Davidson	0.53	0.22	94.40	0.20	0.24	0.08	
61	Tennessee	0.33	Warren	0.26	68.00	31.00		0.20	0.24	
62			Forster					1.70		
63	Texas		Hartley					0.96		
64			Eastland	1.2	0.00	18.75	79.00	0.51	0.04	
65		1.0		0.825	44.60	7.34		0.99		
66		1.2		3.5	17		1	7.07		
67	Utah (Harley Dome)		Grand		(Also contains neon)			2.30		
68			San Juan	0.26	48.05	28.15	22.78	0.76		
69			Grand	0.00	23.80	25.84		2.16		
70			Benton	0.39	0.17			trace		
71	Washington			0.11	68.50	10.00		0.06		
72	West Virginia	1.25	Framont	1.35	23.40	59.40		0.02		
73	Wyoming		Sweetwater	5.46	1.16	37.35	8.40	46+	0.89	
74		1.85		0.487	97.50		1.27	0.00		

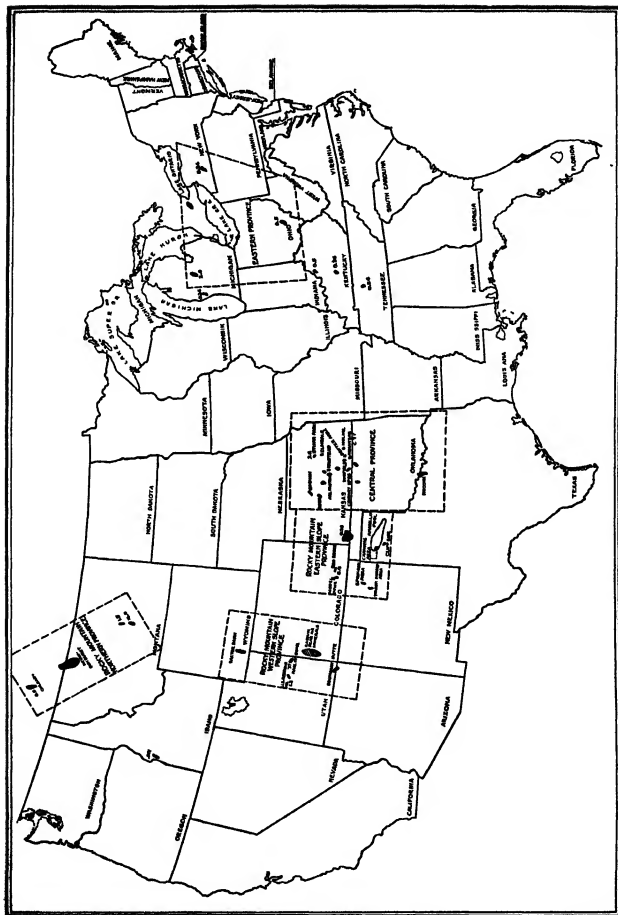

FIG 1 Principal Helium bearing Areas in the United States

NATURAL AND REFINERY GASES

The Rocky Mountain Eastern Slope Province contains probably the most important of the present industrial sources of helium. There are five main areas so far discovered in this province. The Cliffside Structure near Amarillo, Texas, is the gas-pool from which the Government helium plant obtains its supplies of helium-bearing gases. The Channing area comprises the western part of the great Amarillo gas-pool. In the south-west corner of Kansas is another large pool in which some of the geological formations carry gas with a helium content of about 0.75%. In the south-eastern corner of Colorado in Las Animas County are two helium-bearing areas known as the Model Dome and the Red Rocks Structure, both of which produce gas with a helium content of 8%. The Model Dome is another source of gas from which the Helium Company produces helium. In this same province in north-eastern New Mexico there are two other helium-bearing areas known as the Springer area and the Wagon Mound area. The gas from these two areas is high in carbon dioxide content, one of these in excess of 97% and the other in excess of 65% CO₂.

In the Rocky Mountain Western Slope Province are located four main helium-bearing areas that have been so far discovered. These are the Baxter Basin field in southern Wyoming, the Harley Dome in Grand County, Utah, and the U S Helium Reserve No. 1, known as the Woodside Dome, in Emery County, Utah, and the Boundary Butte Structure in San Juan County, Utah. The gas in the Harley Dome analyses 7.7% helium, while that in the Boundary Butte area analyses approximately 1% helium. On the map in Fig. 1 there is also shown a shaded area where helium-bearing minerals occur. This fact is interesting as throwing some light on the origin of helium in this province. The Rocky Mountain Northern Province is of minor importance at the present time as a source of helium-bearing gas, although a gas carrying 16% helium has been discovered in central Montana. The well from which this helium was obtained, however, had but a small production of gas and the helium reserves would be rather light. The Kevn Sunburst field in northern Montana contains some helium-bearing gas, and farther to the north-west the Bow Island field near Calgary in Alberta produces gas in some instances analysing as high as 0.8% helium. The Eastern Province, which centres around Lake Erie, has but one helium-bearing area in which helium-bearing gas of commercial quality is produced. This is a small field in Isabella County in central Michigan.

Estimated Quantity of Helium Available

A number of attempts have been made to estimate the reserves of helium which have already been discovered in the United States. The following is perhaps the most complete estimate that has been made. This estimate was made by engineers of the Helium Company.

	<i>Recoverable helium, cu ft</i>
<i>Eastern Rocky Mountain Helium Province</i>	
South-eastern Colorado Helium District	
Model Dome, Las Animas County, Colo	68,000,000
Red Rocks Dome, Las Animas County, Colo	20,000,000
<i>North-western New Mexico Helium District</i>	
Springer, Colfax County, New Mexico	3,000,000
Wagon Mound, Mora County, New Mexico	5,000,000
<i>North-western Texas Helium District</i>	
Channing, Hartley County, Texas	180,000,000
Cliffside Structure, Potter County, Texas (John Wray and Bush Domes)	1,000,000,000
Total	1,276,000,000

	<i>Recoverable helium, cu ft</i>
<i>Western Rocky Mountain Helium Province</i>	
<i>South-western Wyoming Helium District</i>	
North Baxter Basin, Sweetwater County	583,000,000
South Baxter Basin, Sweetwater County	698,000,000
Woodside (U S Helium Reserve No. 1), Emery County, Utah	1,118,000,000
<i>Harley Dome Helium District</i>	
Harley Dome, Grand County, Utah	115,000,000
<i>Boundary Butte Helium District</i>	
Boundary Butte, San Juan County, Utah	41,000,000
Elk Ridge, San Juan County, Utah	20,000,000
Organ Rock, San Juan County, Utah	20,000,000
San Juan Lime Ridge, San Juan County, Utah	20,000,000
Total	2,615,000,000

<i>Central Helium Province</i>	
Arkansas City Pool, Cowley County, Kansas	18,000,000
Arlington Pool, Reno County, Kansas	240,000,000
Bison Area, Rush County, Kansas	54,000,000
Conway Springs, Sumner County, Kansas	112,000,000
Derby Area, Sedgwick County, Kansas	99,000,000
Dexter Area, Cowley County, Kansas	172,000,000
Elmdale Area, Chase County, Kansas	21,000,000
Gorham, Russell and Ellis Counties, Kansas	480,000,000
Halstead, Harvey County, Kansas	196,000,000
Moline Pool, Elk County, Kansas	100,000,000
Nocona, Montague County, Texas	200,000,000
Sylvan Park, Morris County, Kansas	105,000,000
Winfield, Cowley County, Kansas	240,000,000
Total	2,037,000,000

Summary

Eastern Rocky Mountain Helium Province	1,276,000,000
Western Rocky Mountain Helium Province	2,615,000,000
Central Helium Province	2,037,000,000
Grand total estimated helium reserves of United States	5,928,000,000

In addition to the above there is one other major gas-pool which carries a helium content of 1.8%, whose location has not yet been divulged and which has an estimated reserve of recoverable helium in excess of 2,500,000,000 cu ft. This gas occurs at a depth of nearly 4,000 ft., and has a rock pressure in excess of 100 atm. Sufficient drilling has been done in the field, such that an estimate of the gas-producing area and consequently the volume of recoverable gas can be estimated with some degree of certainty.

Industrial Production of Helium

In the technical methods of producing helium the difference in the various physical properties of the constituent gases, particularly in the boiling-point, is taken advantage of in effecting the separation of the helium from the other constituents. Helium, being the most difficult gas to liquefy, makes it very easy, therefore, to separate helium from other constituents with which it is associated by liquefaction of the other constituents and the separation of the gaseous helium from the liquid. Every process for the production of helium is based primarily on these facts.

In the accompanying diagrams, Figs. 2 and 3, are shown schematically the methods by which helium is separated from natural gases. Fig. 2 shows in schematic diagram the process used at the Government plant at Amarillo, Texas. Referring to the diagram, the high-pressure gas enters the apparatus through a gas heat exchanger and is conducted into a combined liquefier and heat exchanger where a large

part of the hydrocarbons are liquefied. This mixture of liquid and gas is then conducted to a separator pot where the liquid is trapped out. The crude helium remaining after separation of the liquid is throttled from the top of this separator pot into an additional separator where more of the gases are liquefied. The low-pressure crude helium is then conducted through a helium heat exchanger to a crude helium compressor where the pressure is increased about 2,000 lb., and then returned to the apparatus again through the helium heat exchanger counter-current to the low-pressure crude helium, then to a purifier column where the residue of nitrogen and hydrocarbons are liquefied in a coil and trapped out in a separator in the base of the column. The high-pressure crude helium is then taken off the top of the separator and passes out of the apparatus through the helium heat exchanger, and is conducted to storage. In the operation of this cycle, the necessary refrigeration for maintaining liquid-air temperature is derived from a nitrogen cycle shown on the right-hand part of the diagram. This nitrogen refrigeration cycle is a modification of the Claude cycle, and obtains its refrigeration by expansion of the gas in standard Claude expansion engines. The liquid is then conducted to the helium purifier column, and this liquid nitrogen surrounds the coil through which the high-pressure crude helium is circulated. The Government plant at Amarillo, Texas, was put into operation in 1928 and produces helium of about 98% purity for Government lighter-than-air craft.

In Fig 3 is shown in diagrammatic section the process utilized by the Helium Company [8, 1912] for the production of helium. Whereas the Government plant utilizes a 'two-step' process for the production of helium, together with an external refrigeration cycle, the process represented in Fig 3 utilizes a 'single-step' process and makes use of the gas itself for obtaining the necessary refrigeration to maintain sufficient liquid nitrogen in the purifier to obtain separation. The natural gas enters the system through a low-pressure gas main, is compressed to a high pressure, that is, from 1,500 to 2,000 lb. pressure, is conducted through

a passage in the heat exchanger where it is cooled to a low temperature, then through a coil in the purifier and into a trap where the liquid nitrogen and liquid hydrocarbons

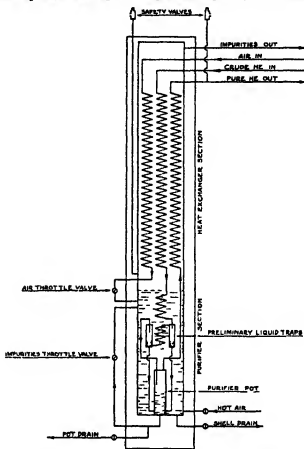

Fig 4 Apparatus for purifying helium contaminated with air

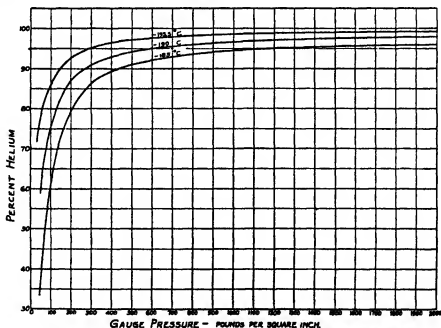

Fig 5. Purity of helium obtained when separating helium from nitrogen at various pressures and temperatures.

are trapped out. These liquids are then throttled by means of a throttle valve into a separator where the helium dissolved in the liquid gases is released. This helium that was dissolved in the gases is returned to the compressor as low-pressure crude helium and then mixed with the original natural gas and recycled. The liquids from the bottom of the separator are throttled into the purifier where such liquids surround the coil and furnish the refrigeration necessary to liquefy the gases. After vaporization the gases pass out of the system through the heat exchanger, cooling the incoming gases to a low temperature. The helium, which is practically 98% pure, is conducted from the top of the liquid trap in the purifier back through the heat exchanger and into storage. This is a highly simplified apparatus, but would not be adaptable to the production of helium from gases low in helium content. The gases utilized by the Helium Company in this apparatus contain from 2-8% helium.

Purification of Helium

Due to the relatively high cost of helium as compared with hydrogen, it has been found necessary in the use of helium in airships to take unusual precautions to conserve such helium. The helium used in airships gradually accumulates air due to leakage, and the airship gradually loses some of its lift. Periodically this helium is withdrawn from the airship and re-purified for further use. The method of purification of helium is basically the same as the method of producing helium from natural gases. In Fig 4 is shown diagrammatically the type of helium purification apparatus

as used in the purification of helium for airships. The helium is withdrawn from the ship when air has accumulated to the extent of about 15% of the volume of the helium. Therefore, due to the large percentage of helium in the gases to be purified, the "single-step" system, as shown in Fig 3, cannot be used without external refrigeration. Therefore in this system a separate cycle for the liquefaction of air is used to furnish the necessary refrigeration to obtain the liquid-air temperatures required to condense the impurities out of the helium. In this system the crude helium is compressed to a pressure of about 2,000 lb per sq in and passed into the apparatus through one passage in the heat-exchanger section, then through a series of liquid traps. The purified helium is taken off the top of the trap and returned through a passage in the exchanger and into storage. The chart, Fig 5, shows the purity of helium that can be obtained at various pressures and temperatures when helium is so treated.

TABLE II
Properties of He, N₂, and CH₄

	He	N ₂	CH ₄
Crit temp, °C	-267.94	-146.53	-82.1
Crit pressure atm	2.26	33.49	45.6
Boiling-point, °C	-268.91	-195.59	-161.61
Freezing-point, °C	-271	-201	-184
Sp heat cal/g	1.26	0.248	0.405
Density pounds 0-760° per cu ft	0.01115	0.07808	0.04475
Latent heat of vaporization cal/g	15.15	47.65	123.0
Thermal conductivity	339 × 10 ⁻⁶	56.9 × 10 ⁻⁶	64.7 × 10 ⁻⁶

REFERENCES

- 1 *Bortech* Z 4, 112 (1935)
- 2 BORTON, R. R. U S P 1,881,115 (1932)
- 3 CADD, H. P., and MCFARLAND, D. F. *J A C S* 29, 1533 (1907)
- 4 KANO, Y., and FAMAQUHI, B. *Rep Aero Res Tokyo*, 1, 347 (1926)
- 5 MONBEAU, C., and LEPAPE, A. *Compt rend* 153, 847, 1043 (1911)
- 6 RAMSAY, W. *Nature*, 51, 543 (1895)
- 7 SHELBURNE ROGERS, G. *U S Geol Survey, Prof Paper* 121 (1921)
- 8 SHVEYKING, H., and LAUTENSCHLAGER, L. *Phys Z* 13, 1043 (1912)

THE ANALYSIS OF PETROLEUM GASES

By H. M. STANLEY, Ph.D., A.M.Inst.P.T.

Research Chemist, Distillers Company Ltd, Epsom

NATURAL gas, which is found in many parts of the world, either alone or, more usually, in association with crude petroleum, consists essentially of a mixture of homologous hydrocarbons of the paraffin series, including methane, ethane, propane, *n*-butane, isobutane, &c. While the so-called 'wet' natural gases contain appreciable quantities of the higher homologues of methane, the latter is the predominating hydrocarbon constituent of the 'dry' gases. Natural gases contain, in addition to hydrocarbon constituents, varying amounts of non-hydrocarbon gases, such as carbon dioxide, nitrogen, hydrogen sulphide, and helium. The absence of unsaturated hydrocarbons, hydrogen, and carbon monoxide from natural gases sharply differentiates them from the gaseous products of cracking or of destructive distillation of carbonaceous substances. Benzene, cyclopentane, and cyclohexane hydrocarbons are known to occur in small quantities in wet natural gases, but cyclopropanes and cyclobutanes are generally believed to be absent.

The gases produced as a by-product in the commercial cracking of hydrocarbons for the production of motor fuels, i.e. the so-called 'cracking gas' or 'cracked gas', contain, in addition to paraffin hydrocarbons, appreciable proportions of hydrogen and unsaturated hydrocarbon gases, including ethylene, propylene, the butylenes, 1,3-butadiene, &c. Non-hydrocarbon constituents, such as nitrogen and hydrogen sulphide, may also be present, while carbon monoxide may also occur in gases produced when cracking is conducted in the presence of oxygen or steam.

The analysis of the complex mixture of saturated and unsaturated hydrocarbons present in many petroleum gases presents difficulties not encountered in the quantitative examination of other common gaseous fuels, such as coal gas, coke-oven gas, and producer gas, in which methane, ethane, and ethylene are the main hydrocarbon constituents. In the case of the latter gases, therefore, a combined absorption and combustion method is generally sufficient to furnish complete analytical data. Such methods are, however, quite inadequate in the case of petroleum gases, in which at least three members of a homologous series usually occur together.

The profound importance of reliable analytical methods for the quantitative examination of gaseous hydrocarbon mixtures is now widely recognized. They are essential in the control of certain plant operations, particularly in the production and stabilization of natural-gas gasoline, and are of vital significance in the rapidly developing industry based on the chemical utilization of the gaseous products of cracking. Progress in pure research on the thermal transformation of hydrocarbons has also been greatly facilitated by the substantial advances made in analytical technique during the last few years.

The usual methods of gas analysis, involving absorption and combustion procedure, may be used, with suitable modifications, for the examination of petroleum gases, but only in special cases can complete information be obtained by such means. By a series of absorptions in suitable liquid reagents, certain of the non-hydrocarbon constituents of petroleum gases, such as carbon dioxide, hydrogen sul-

phide, oxygen, and carbon dioxide, as well as the total content of unsaturated hydrocarbons can be readily estimated. Moreover, absorption in sulphuric acid of suitable concentrations may serve to furnish valuable information as to the type of unsaturated hydrocarbons present in such gas mixtures, although complete analytical data on this point cannot usually be obtained in this manner. However, the ordinary combustion or explosion methods of analysing residual mixtures of nitrogen (and helium) and paraffin hydrocarbons are only applicable when not more than two such paraffin gases are known to be present. This limitation renders the precise analysis of most petroleum gases quite impossible by simple absorption and explosion procedure unless some physical method of segregation of the paraffin hydrocarbons is first applied. The newer developments in the analytical investigation of complex hydrocarbon gas mixtures involve the partial or complete separation of the component hydrocarbons by refined physical methods, the most important being fractional distillation or condensation. In general, therefore, a complete quantitative examination of complex gas mixtures can only be effected by a combination of all the three main methods of analysis, namely

- (i) Absorption methods
- (ii) Combustion, or explosion methods
- (iii) Physical methods of segregation.

Absorption Analysis

Since the subject of gas analysis by absorption is adequately described in numerous text-books, only a brief description of such methods with special reference to their application to petroleum gases becomes necessary here. Briefly, the absorbable gaseous constituents, carbon dioxide, hydrogen sulphide, acetylene, oxygen, unsaturated hydrocarbons (including monoolefines, diolefines, and aromatic hydrocarbon vapours), and carbon monoxide, are quantitatively absorbed in a series of absorptions in contact with suitable liquid reagents, the absorptions being conducted in a definite order. Since the absorbent medium used for any particular constituent must be specific and must not absorb more than traces of other constituents, the choice of suitable reagents is limited and the order of successive absorptions of prime importance.

Various forms of apparatus are employed for absorption analysis, but accurate results can only be obtained by observing certain precautions. Thus, while the amount of reagent employed should be ample, excess of absorbent should be avoided, while the time of contact should also be standardized. For optimum results, it is desirable to use fresh reagent for each absorption. In England, the Bone and Wheeler apparatus, modifications of which have been well described by Blair and Wheeler [2, 1922] and by Grace and Payman [21, 1924], is employed extensively for accurate work since it embodies all the above features. In this apparatus gas measurements are made in terms of pressure at constant volume rather than as volume at constant pressure. Moreover, all absorptions are carried out over mercury, using only 2-5 ml of reagent per absorption.

and for standardized times of contact. Similar features are also embodied in the precise Orsat apparatus developed by the U.S. Bureau of Mines and described by Shepherd [46, 1931].

Whatever form of apparatus is employed, the gaseous constituents of complex mixtures may be successively absorbed by the following reagents for times of contact of 2-5 min and observing the following order of absorptions:

(1) Carbon dioxide and other acidic gases, such as hydrogen sulphide and sulphur dioxide, are absorbed in 40% aqueous solutions of caustic potash.

(2) Acetylene is absorbed in a reagent due to Lebeau [27, 1917] and prepared by dissolving 25 g of mercuric iodide and 30 g of potassium iodide in 100 ml of water and mixing with an equal volume of 40% aqueous caustic potash solution in the pipette immediately before use. Other proposed reagents, such as ammoniacal cuprous chloride and silver salts, exert a marked solvent action on carbon monoxide and olefine hydrocarbons. However, where only traces of acetylene are present, this hydrocarbon is most conveniently estimated in a separate analysis by means of a colorimetric method suggested by Riese [40, 1931].

(3) Oxygen may be absorbed in a solution obtained by mixing in the pipette immediately prior to absorption 4 vols of 40% aqueous caustic potash and 1 vol of a concentrated solution of pyrogallol in water (28 g of pyrogallol in 100 ml of water). Dilute sulphuric acid solutions of chromous sulphate are also satisfactory and specific absorbers for oxygen, but are less readily prepared than alkaline pyrogallol.

(4) Unsaturated hydrocarbons, including both mono- and diolefines, are best estimated by a series of absorptions in aqueous sulphuric acid of increasing concentrations, as described later. In general, tertiary olefines such as isobutylene and trimethylethylene are absorbed in 63-8% sulphuric acid, propylene, *n* butylenes and butadiene in about 87% sulphuric acid, and the residual ethylene is finally removed by means of one or other of the reagents proposed for determining the total unsaturated hydrocarbon content. For the latter purpose a suitable reagent, proposed by Tropsch and Dittrich [50, 1925], consists of a mixture of 15 vols of a 0.6% solution of silver sulphate in concentrated sulphuric acid and 1 vol of a saturated solution of nickel sulphate also in concentrated sulphuric acid. This reagent readily absorbs ethylene and other olefines but, unlike fuming sulphuric acid, has no tendency to dissolve paraffin hydrocarbons. Another reagent for the estimation of ethylene, or total unsaturated hydrocarbons, is a saturated solution of bromine in 5% aqueous potassium bromide, preferably diluted with at least an equal volume of water. The disadvantages of this reagent include a tendency to foul the mercury-containing liquid and to attack saturated hydrocarbons. The latter effect is most pronounced in bright sunlight and can be minimized by employing a blackened absorption pipette, as advocated by Boyd and Oberseider [4, 1931]. Schultze [44, 1932] has described the precautions necessary when using bromine water in exact gas analysis.

The use of fuming sulphuric acid or bromine water to absorb ethylene necessitates a final washing of the gas with caustic potash solution prior to measurement.

(5) Carbon monoxide is conveniently absorbed in an ammoniacal solution of cuprous chloride, prepared by adding concentrated aqueous ammonia (density 0.88) to a suspension of 75 g of cuprous chloride in 200 ml of a

12.5% aqueous solution of ammonium chloride until complete dissolution takes place. The reagent should be freshly prepared and stored in air-tight containers. Several absorptions, each of 5 min duration and with fresh reagent for each absorption, are necessary to ensure complete removal of the carbon monoxide. Before final measurements are taken, the gas should be washed with 5% aqueous sulphuric acid to remove ammonia vapour.

Estimation of Hydrogen and Paraffin Hydrocarbons by Combustion or Explosion Methods

After the reactive gaseous constituents have been removed in the above series of absorptions, the residual gas may contain, in addition to traces of helium and rare gases, nitrogen, paraffin hydrocarbons, and, possibly, small amounts of carbon monoxide remaining undissolved from the treatment with ammoniacal cuprous chloride solution. Even when methane and ethane are the only paraffinic gases present, as in coal gas, complete analytical data can only be obtained by explosion or combustion methods if the hydrogen is first removed and estimated. In the case of gases containing other paraffin hydrocarbons in addition to methane and ethane, a preliminary partial or complete segregation by physical methods is necessary before the analysis can be completed.

Hydrogen.

Hydrogen (as well as traces of carbon monoxide) may be estimated in mixtures containing nitrogen and paraffin hydrocarbons by taking advantage of its greater ease of oxidation. According to Grice and Payman [21, 1924], 'oxidized' palladium sponge, prepared by heating ordinary palladium sponge to a dull red heat in air, rapidly and quantitatively absorbs hydrogen, partly by oxidation and partly by occlusion, leaving the paraffin hydrocarbons and nitrogen unchanged. Contact of the gas with the palladium sponge at 100° C for 15-20 min is usually sufficient for complete absorption, the sponge being frequently revived by heating in contact with air. In admixture with methane and ethane, hydrogen may be determined by catalytic oxidation (in contact with 8 vols of oxygen) in the presence of a bed of activated palladium black at 80-90° C. MacGillivray [30, 1932] has found that the temperature of the palladium is important, since explosions may result if too high temperatures or too rapid passage of the gas are used. For high concentrations of hydrogen a temperature of 80° C is sufficient, but the temperature should be raised to 90° C if less than 20% of hydrogen is present. A solution of colloidal palladium at 50° C has also been used for the analytical absorption of hydrogen in gas mixtures [37].

The very convenient method developed by King [24, 1922] for the determination of hydrogen depends upon the rapid preferential oxidation of this gas to water under the influence of copper oxide at 280-300° C. In the absence of appreciable oxidation of paraffin hydrocarbons the hydrogen content is thus measured directly by the contraction in volume resulting from the oxidation treatment. Any carbon monoxide present becomes oxidized to carbon dioxide and may be estimated by the usual absorption procedure. About 30 min is required for the preferential oxidation, which is quite satisfactory for mixtures containing methane as the main paraffinic constituent. However, it has been shown by King and Edgcombe [25, 1931] that ethane, propane, and butane undergo a slow oxidation in contact with freshly prepared copper oxide at 280° C,

NATURAL AND REFINERY GASES

so that hydrogen determinations by the King method are subject to small errors if substantial proportions of the higher gaseous paraffins are present

Paraffin Hydrocarbons.

The gaseous mixture remaining after removal of all absorbable constituents and hydrogen consists of paraffin hydrocarbons and nitrogen as well as, possibly, the rare gases. By complete combustion of the paraffin hydrocarbons and absorption of the carbon dioxide produced, the mean molecular weight of the paraffin gases present (or the mean value of n in the formula C_nH_{2n+2}) may be readily deduced. At the same time the residual non-hydrocarbon gases may be measured directly. In cases where not more than two paraffin hydrocarbons of known molecular weight are present, the data obtained by complete combustion are sufficient for complete analysis. *In the general case, however, combustion alone is inadequate to furnish complete analytical data and can only indicate the content of total paraffinic gases and the mean molecular weight of the mixture.*

For the complete combustion of gas mixtures containing paraffins and nitrogen, the so-called *explosion method* is widely used. In this method a suitable volume of the gas is mixed with an excess of air, or oxygen, and exploded by a spark, suitably in a pear-shaped explosion vessel. Care must be taken that a sufficient excess of oxygen is present and that the explosion vessel and mercury-containing medium are clean. From the contraction in volume due to the explosion, the volume of carbon dioxide produced and the oxygen consumed, the mean value of n and the percentage of C_nH_{2n+2} hydrocarbons may be calculated from the following relationships:

$$\frac{\text{Carbon dioxide produced}}{\text{Contraction on explosion}} = \frac{2n}{n+3}$$

$$\frac{\text{Carbon dioxide produced}}{\text{Oxygen consumed}} = \frac{2n}{3n+1}$$

$$\text{Volume of } C_nH_{2n+2} \text{ hydrocarbons} \\ = \frac{\text{Volume of carbon dioxide}}{n}$$

Although simple in theory, the explosion method is frequently attended with considerable practical difficulties. Thus the adjustment of the correct excess of oxygen often requires many trial tests when analysing gases of unknown composition. Moreover, in the presence of the higher paraffin hydrocarbons the large oxygen requirement and lower explosive limits render the use of air alone quite impossible unless electrolytic gas is added to produce an explosive mixture. On the other hand, when oxygen or air-oxygen mixtures are used, the explosion is very violent and there is some risk of oxidation of tap grease. However, MacGillivray [30, 1932] has shown that ethane-methane mixtures may be analysed satisfactorily by explosion with 12 vols of pure oxygen.

A less accurate, but much more convenient, method of analysis of paraffin gas mixtures consists in passing the gas, in the absence of added air or oxygen, over copper oxide heated to 700–800° C in a quartz tube, whereby the hydrocarbons are oxidized to carbon dioxide and water. Although the oxidation is never quite quantitative owing to the retention of small amounts of the carbon on the copper oxide, this error is relatively small and the method is well adapted to a preliminary examination of unknown gases prior to the use of the explosion method. The addition of

lead chromate and cobalt oxide has been found by Campbell and Gray [7, 1930] to increase the activity of the copper oxide in the oxidation. The analytical results obtained by this method may be interpreted as follows: If

A = volume of gas mixture before combustion,
 B = volume after combustion,
 and C = volume after absorption of CO_2 ,

then

$$\left. \begin{aligned} \text{volume of } C_nH_{2n+2} &= \frac{A-C}{B-C} \\ \text{mean value of } n &= \frac{A-C}{A-C} \\ \text{and} \quad \text{volume of nitrogen} &= C \end{aligned} \right\}$$

Complete combustion of paraffin hydrocarbons in excess of air or oxygen may also be effected in the presence of a heated platinum spiral, a method which obviates much of the trouble associated with the explosion method. This method is particularly useful in the determination of very low concentrations of paraffin hydrocarbons in air.

Physical Methods of Gas Analysis

As previously pointed out, the usual absorption and combustion methods of analysis are adequate to furnish complete analytical data only in the case of special gas mixtures containing relatively few hydrocarbons. In the analysis of the usual type of petroleum gases, some physical means of partial or complete segregation is essential, the usual methods involving fractional condensation or distillation of the hydrocarbon mixture under conditions suitable for the accurate measurement of the fractions obtained. A number of other methods of segregation have also been advanced, including fractional absorption in suitable solvents or preferential adsorption in charcoal or silica gel.

Methods Involving Fractional Condensation or Distillation.

Two distinct types of procedure must be distinguished, in both of which the gas mixture under examination is subjected to liquefaction at low temperatures, usually at the temperature of liquid air or nitrogen. In one mode of operation, which may be termed the fractional condensation method, the liquefied mixture is subjected to a series of simple distillations or condensations at very low pressures with a minimum of rectification. In the second type of procedure the liquefied gas mixture is rectified in suitable fractionating columns at low temperatures, but at substantially atmospheric pressure. The former method relies entirely on the wide differences in vapour pressures of individual hydrocarbons at very low temperatures, whereas the latter system depends on efficient rectification.

Simple fractional distillation at low pressures and temperatures was applied to the analysis of natural gas by Burrell and Seibert [5, 1915] in 1914, advantage being taken of the previous pioneer work of Travers [49, 1901], Erdmann and Stoltzberg [16, 1910], and Lebeau and Damiens [28, 1913]. The natural gas was first liquefied at liquid air temperatures and the different paraffin hydrocarbons distilled off at suitably adjusted temperatures and at low pressures. Methane was removed at liquid air temperature, ethane at –150° C to –140° C, and propane at –135° C to –120° C. Subsequently, Shepherd and Porter [47, 1923] developed a more complicated apparatus on the same principle, in which the number of manipulations and time

THE ANALYSIS OF PETROLEUM GASES

required were reduced. In spite of the complicated apparatus and technique, the degree of separation obtained with the Shepherd-Porter method was relatively poor in the case of the butane and pentane fractions, so that the application of this procedure has been limited mainly to special research work. More recently Shepherd [45, 1929] has described a modification of the Shepherd-Porter apparatus specially designed for the accurate determination of the gasoline content of natural gas, but also applicable to the analytical separation of natural gases by fractional isothermal distillation. Here, again, the procedure involves a large number of simple distillations and condensations at selected low temperatures.

In the analytical method due to Tropisch and Dittrich [50, 1925] the gas mixture is liquefied at the temperature of liquid air and, after removal of all uncondensable gas and practically all the methane by the application of high vacuum, the residual gas is subjected to fractional condensation at low pressure in a series of bulbs cooled to -90°C , -120°C , and -180°C respectively. In this way, there are obtained three fractions, each containing only two paraffin hydrocarbons (i.e. ethane and propane at -180°C , propane and butane at -120°C , and butane and higher paraffins at -90°C), associated with the corresponding olefine hydrocarbons, if originally present. Each fraction can thus be analysed separately by the usual absorption and combustion procedure so that complete analytical data can be obtained. The method fails, however, to characterize the higher hydrocarbons condensed along with the butanes, while numerous subsidiary analyses are necessary. In order to minimize the labour involved in analysing the several fractions obtained, Tropisch and Mattox [51, 1934] have devised a simplified procedure in which each fraction is washed with sulphuric acid absorbent of suitable concentration to remove olefine hydrocarbons and the residual mixture of two homologous paraffins analysed by density measurements in a Stock electromagnetic gas-density balance.

All analytical methods involving multiple simple distillations or fractional condensation at low pressures involve complicated analysis and technique so that rectification methods, which possess obvious theoretical advantages and permit of fairly sharp separations in one operation, have now largely displaced the former methods. Nevertheless, although the tedious and cumbersome, though accurate, Shepherd-type apparatus has been discarded, the basic features of the method have been retained in a short-cut control method described by Rosen and Robertson [41, 1931], which requires only 200–50 ml of liquid nitrogen refrigerant and can be completed in 60–75 min. This procedure, which is limited to the analysis of ternary mixtures containing ethane, propane, and butanes and to such mixtures containing, in addition, methane and fixed gases, involves simple distillation without fractionation, the results being correlated by means of a master-graph. The procedure has also been extended to the rapid analysis of stabilizer bottoms and similar gases containing propane, butane, pentane, and heavier hydrocarbons [42, 1934].

The outstanding advance in the analysis of complex hydrocarbon mixtures by physical methods is undoubtedly the development of efficient fractionating columns capable of being applied to the precise distillation of small amounts of hydrocarbon liquids at temperatures down to about -190°C . Progress in this field has been largely due to the pioneer work of Podbielniak, although Frey and Yant [18, 1927] described a pyrex fractionating column suitable

for the fractionation of a butane fraction several years prior to the publication of Podbielniak's work.

The Podbielniak Apparatus [38]

The apparatus consists essentially of (a) an efficient pyrex fractionating column, connected to (b) a mercury manometer through (c) a second mercury manometer to (d) an evacuated receiver of known value, or, alternatively, to a series of such calibrated receivers. The complete layout of equipment is shown in Fig 1, which also shows an arrangement of fraction-collecting burettes in cases where it is desired to subject individual fractions to further examination, i.e. for the determination of olefines by absorption methods. Several types of fractionating column have been developed by Podbielniak for various temperature ranges and degrees of sensitivity, but all are vacuum jacketed and silvered opaque except for two clear vertical slits for purposes of observation. In the earlier type of column the jacket and the column were constructed in one piece, but this type is now obsolete. In the standard precision equipment now generally used the jacket and reflux chamber are constructed in one piece independently of the column proper, and air-currents in the annulus between the column and the loose-fitting jacket are minimized by suitable packing material placed at the base of the jacket and of the reflux chamber. The distilling bulb is also vacuum jacketed and is heated by means of an external resistance wire, the heat input being controlled by suitable variable resistances. A very important feature of the column is the wire packing which is claimed by Podbielniak to give most efficient fractionation with maximum contacting of liquid and vapour and minimum hold-up of refluxing liquid. Reflux control is obtained by means of the reflux-cooling chamber at the top of the column and so designed as to allow of regulated heat removal. In earlier types of equipment cooling was effected by a bath of gasoline cooled by the introduction of regulated amounts of refrigerant (liquid air, or, preferably, nitrogen) into cooling coils immersed in the bath. In an improved type of cooling vessel, liquid reflux baths are eliminated and, instead, heat transfer is effected through the medium of fine copper powder filling the annular space between the column and the metal cooling vessel, the latter being fed with controlled amounts of refrigerant. It is also possible, in this type of apparatus, to introduce the refrigerant directly on to the glass wall of the column when methane and other low-boiling liquids are being fractionated. Vapour temperature is measured by means of a thermocouple located near the top of the fractionating column.

The analysis is carried out by liquefying all, or part, of the sample in the distilling bulb and subjecting the liquid to careful fractionation, the volume of the gaseous overhead products being measured in receivers of known volume (initially evacuated) connected to mercury manometers. Uncondensable gas first passes into the receiver, after which methane commences to distil. During the course of the distillation, observations of vapour temperature and receiver bottle pressure are recorded at short intervals. The gas sample, which should preferably have a gas volume of at least 6 litres, must be freed from moisture and carbon dioxide (by passage over magnesium perchlorate trihydrate and potash respectively) prior to introduction into the apparatus. The gas sample is introduced into the evacuated column via a precooled tube attached to the distilling bulb, both tube and bulb being cooled with liquid air or nitrogen. In this way most of the methane

and all the higher hydrocarbons are condensed and the column will contain uncondensable gas with a little methane. Alternatively, the bulk of the methane may, if desired, be vented from the top of the column simul-

taneously with the introduction of the gas, by cooling the distilling bulb in a gasoline bath maintained at an appropriate temperature. Where a series of gas-sampling burettes are available, the methane and uncondensable gas may be

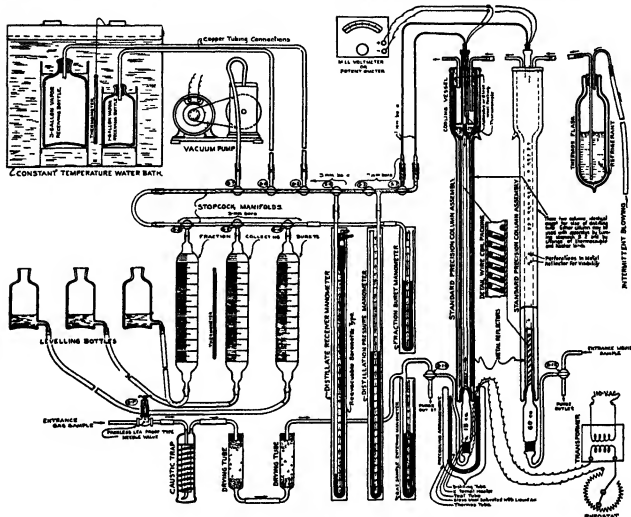

Fig 1 Diagram of standard precision apparatus

(Reproduced by permission from W J Podolsnik, 'Ind Eng Chem' (1933-5), p 173)

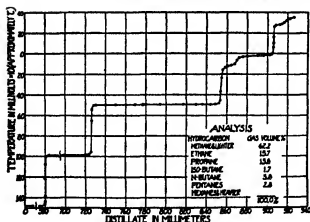

Fig 2. Low-temperature distillation of natural gas

(Reproduced by permission from W J Podolsnik, 'Ind Eng Chem' (1933-5), p 139)

collected in one fraction and subsequently analysed by explosion methods, thus reducing the time of distillation.

As soon as all the sample has been introduced into the column, the column pressure is brought to atmospheric by applying a small current to the distilling bulb and, by balancing this heat input and the supply of refrigerant to the reflux chamber, the column pressure can be maintained at any desired value during the distillation. Efficient fractionation can only be obtained if the column were packing is wetted with the minimum amount of reflux to form capillary films, and flooding of the column should be avoided as far as possible. All hydrocarbons boiling below room temperature may be fractionated at atmospheric pressure, but it is recommended that pentanes and pentenes should be distilled at 300 mm, hexanes and hexenes at 100 mm, and heptanes at 20 mm. The apparatus is unsuitable for the fractionation of hydrocarbons of more than 7 carbon atoms. By a careful control of the distillation, one hydrocarbon after another is distilled with sharp temperature rises until the whole sample is distilled or an

undistillable residue remains. The series of simultaneous readings of column pressure, reflux temperature, and receiver pressure taken at short time-intervals during the distillation are used to construct a graph of vapour temperature (corrected to a standard pressure) against distillate volume. The resulting graph shows a series of plateaux, each corresponding to individual hydrocarbon constituents, with practically vertical separating lines in the case of the lower boiling fractions. Typical results obtained in the fractionation of a natural gas are shown in Fig 2. Podbielniak recommends that the cut-points be determined by the 'equal area' method rather than by the mid-point. The amounts of each individual constituent, identifiable from the boiling-point, are thus determined from the distance between the cut-points.

Accurate and reproducible results on this type of analytical distillation can only be obtained by rigid standardization of apparatus and technique. In order to obviate the personal factor as much as possible, Podbielniak [39, 1932] has developed an automatic control device which supplies refrigerant to the reflux cooler, controls distillation rate according to the difficulty of fractionation, summons the operator with a buzzer and warning light whenever assistance is required, and produces a complete distillation curve showing the distillation rate throughout the analysis.

Several investigators, including Schaufelberger [43, 1930], MacGillivray [30, 1932], and Vandaveer [55, 1931], have described fractionating equipment for the analysis of hydrocarbon gases very similar in principle to, but differing somewhat in details from, that advanced by Podbielniak. The MacGillivray column is of interest in that reflux cooling is controlled by means of a variable-pressure hydrogen buffer interposed between the reflux chamber and the cooling cup, which is filled with liquid nitrogen. The column proper consists of two lengths of glass tubing connected by three turns of a glass helix acting as an expansion joint, the whole being vacuum jacketed. The packing material consists of a glass rod wound with new silver wire. An increased degree of reflux control is obtained by silvering the hydrogen buffer chamber only up to a certain level so that cooling due to radiation is dependent upon the level of the refrigerant in the cup. The mode of operation of the MacGillivray does not differ in any important respects from that used in the Podbielniak apparatus.

A critical study of apparatus design and operating technique and analytical fractionation of low-boiling hydrocarbons has been contributed by McMillan [31, 1936], who has also compared the efficiencies of various columns using synthetic hydrocarbon mixtures of known composition. McMillan points out that the Podbielniak and similar methods of analysis, in spite of their obvious theoretical and practical advantages, have yielded erratic results and met with considerable criticism mainly because analytical results could not be correlated when run on different apparatus or by different operators, while serious discrepancies have been too frequently found when plant production or laboratory yields are checked against analyses. One serious source of error is due to excessive dead space in the apparatus, and it was found that, towards the end of distillations when the packing was almost dry, a false break was obtained, the amount of gas left in the column being almost exactly equal to the volume of the kettle, column, and manifold connections. It follows that in the customary procedure for dry-gas analysis, the reported values for pentane plus are almost without exception subject to errors as high as 100% of that fraction. In order

to reduce dead space, McMillan advocates the use of Y-type manometers in place of the open-end manometers ordinarily employed. The most practical method of reducing dead space in the kettle is to fill it with mercury after it has become dry and before reducing the pressure. Alternatively, an auxiliary or 'micro-column', such as that described by Fitch [17, 1931], may be employed for handling the small end fractions, but such a procedure presents certain disadvantages. Other methods of reducing kettle dead-space error include reduction of pressure and the addition of a 'chaser', or substance of higher boiling-point than the heaviest components. McMillan concludes that the use of mercury and reduction of pressure are the simplest and best methods for eliminating dead-space error.

Various column packings were compared by McMillan, who found that most of the suggested packings were inadequate in promoting intimate contact of vapour with reflux liquid. The most suitable packing found by this investigator consisted of a spiral of No. 15 gauge brass wire (6 turns per in.) with an insert of No. 23 gauge straight wire. Another satisfactory packing was a No. 14 gauge aluminum spiral with a No. 23 gauge nichrome insert. McMillan's conclusions regarding the influence of other factors on the efficiency of fractionation may be summarized as follows:

- 1 The heating of the liquid in the distilling bulb is best effected by means of internal heaters, i.e. electric heaters immersed directly in the liquefied gases.

- 2 Superheating of vapours between the surface of the liquid in the distilling bulb and the fractionating section must be reduced to a minimum by efficiently insulating this region from the surrounding relatively warm atmosphere.

- 3 The optimum reflux ratios are somewhat critical and differ for various columns, being 11-15 for the usual Podbielniak columns.

- 4 The design of the condenser section at the top of the column is vitally important if irregularities in the distillation curves (usually in the form of humps or reverse breaks at the end of each plateau) are to be eliminated.

- 5 The best position of the thermocouple at the top of the column is about 7.5 cm below the rim of the condenser bath, but may be varied 5 mm in either direction without materially affecting results.

- 6 From both theoretical and practical points of view, the best method of determining cut-points is to take the temperature at which a 50-50 mol per cent of the binary mixture is in equilibrium in the vapour state. This method has also been proposed by Fitch [17, 1931].

- 7 A careful comparison of various fractionating columns showed that the old 'L'-type and 'Regular' one-piece Podbielniak columns were not very satisfactory, although the latter could be made to give extremely precise results if used in conjunction with McMillan's heavy-type packing and a bead-packed condenser. The Podbielniak 'micro' precision equipment gave good results, although the degree of fractionation and reproducibility did not approach those obtained with a column developed by McMillan and consisting essentially of a California Natural Gasoline Association column [6], modified in accordance with McMillan's conclusions. This modified CNGA column was also simpler to operate, since it gave sharp, smooth breaks in a minimum of time and had no tendency to flood.

Although undoubtedly superior to all other processes for the analysis of hydrocarbon gas mixtures, the methods of precise fractional distillation suffer from certain obvious disadvantages, chief of which are the time required for a

complete analysis (up to 8 hr) and the considerable consumption of liquid air or nitrogen (2-5 litres). Attempts have been made to simplify the procedure and to reduce the consumption of liquid air or nitrogen or to employ the cheaper carbon dioxide in place of liquid air or nitrogen. Thus, in the simple fractional distillation apparatus developed by Davis [8, 1929], a suspension of carbon dioxide snow in acetone is employed as refrigerant. The Davis fractionating column consists of 3-5 metres of 5 mm glass tubing bent into a spiral of 30-40 turns with a low pitch encased in a silvered vacuum jacket, the upright head at the top of the column being surrounded by a cooling cup for reflux control. Distillation is carried out at atmospheric pressure and the distillates are collected in liquid form. The application of this type of column to the analysis of complex hydrocarbon mixtures has been described by Davis and Daugherty [9, 1932]. For this purpose the dried gas mixture is introduced into a condensation bulb, cooled to -80°C , the uncondensed gas being measured and analysed separately. The liquefied hydrocarbon mixture is then subjected to fractional distillation to yield the following fractions, each of which are analysed by absorption and combustion methods.

- (1) A gas cut consisting of ethane, ethylene, and small amounts of methane, propane, and propylene
- (2) A liquid fraction, b.p. up to -30°C , consisting of propane and propylene only
- (3) A butane-butene fraction, b.p. -30°C to $+10^{\circ}\text{C}$
- (4) A pentane-pentene cut, b.p. up to $+45^{\circ}\text{C}$

Although the fractional distillation is simple and rapidly effected, the analysis requires much time for completion owing to the large number of subsidiary analyses involved. Bosschart [3, 1934] has described a fractionating apparatus in which liquids boiling from -170°C to $+200^{\circ}\text{C}$ may be rectified at ordinary pressure in such a way that the highest boiling components are recovered first. This unusual effect is obtained by a species of inverted fractional distillation, the more volatile components being continuously vaporized and returned to the top of the column with fresh liquid feed. In this way the volatile components accumulate at the top of the column while the heavier constituents are rectified in the column and escape from the bottom. This type of apparatus would seem to be particularly useful in the analysis of hydrocarbon gases for their content of higher hydrocarbons, i.e. for gasoline content. In cases where the chief interest of the analysis lies in the content of the higher boiling constituents, this type of analytical fractionation should be economical in time and labour. The original paper should be consulted for details of this ingenious system.

Other Methods for Analysis by Physical Means

Attempts have been made to apply both preferential adsorption and solubility phenomena to the analytical separation of hydrocarbon gases, and Kuhn [26, 1931] has described the use of silica gel at low temperatures for the analysis of coal gas.

An interesting method of gas analysis advanced by Van Dyck [56, 1932] consists in subjecting the gas mixture, under examination, to the solvent action of a regulated slow stream of a suitable solvent (nitrobenzene, toluene, or binary mixtures of these substances) at constant temperature in a specially designed and standardized apparatus. The amount of gas absorbed is measured by volume change at constant pressure, and the results are interpreted by plotting the volume of absorption liquid against the

volume of gas absorbed. No refrigerant is required, and it is claimed that analytical results can be obtained with an accuracy of 0.5%, while the minimum amount of any component which can be identified with certainty is about 2.5%. Rigid adherence to certain specified conditions and to definite dimensions of apparatus is stated to be essential to the success of this procedure.

Special Methods for the Analysis of Unsaturated Hydrocarbon Gases

In analysing gaseous mixtures containing both saturated and unsaturated hydrocarbons, such as fractions obtained during the analytical fractional distillation or condensation of cracked gases, advantage is taken of the high chemical reactivity of the unsaturated constituents to remove these substances by means of reagents which leave the paraffins unattacked under the operating conditions. Reagents which have found wide application for this purpose include sulphuric acid and bromine.

Segregation of Olefines by Absorption with Aqueous Sulphuric Acid of Varying Concentrations

The fact that the total olefine content of gaseous mixtures may be readily determined by absorption in fuming sulphuric acid or in activated concentrated sulphuric acid has already been mentioned. However, on account of the great variation in the rates of reaction of different olefine hydrocarbons in aqueous sulphuric acid solutions, absorption in the reagent may be employed to determine not only the total content of unsaturated gases, but also, in many cases, the proportions of certain individual hydrocarbons in complex gas mixtures. In fact, when absorption in certain graded concentrations of aqueous sulphuric acid is employed in conjunction with some type of physical separation, such as fractional distillation, more or less complete analytical data may be obtained.

The rates of absorption of individual olefine gases in sulphuric acid of varying concentrations have been measured by Michael and Brunel [35, 1909], Tropisch and von Philippovich [54, 1923], Dobryanski [15, 1925], Davis and Schuler [11, 1930], and Marcovitch and Moore [33, 1930-1], while the extensive literature of the subject has been ably reviewed by Tropisch and Mattox [53, 1934]. In general the rate of absorption of any individual olefine gas is proportional to its partial pressure in the gas phase and to the acid surface exposed. As might be expected, absorption rates are greatly dependent upon the concentration of acid and tend to increase rapidly with rising concentration. On the basis of their rates of absorption in aqueous sulphuric acid of different concentrations, the olefine gases may be grouped into the following three main classes, namely:

- (1) Olefines readily absorbed by aqueous sulphuric acid of concentrations of 60-70%. This class includes isobutene, trimethylethylene, 2-methylbutene-1, and isoprene [9, 1932].
- (2) Olefines not readily absorbed in 60-70% sulphuric acid, but easily absorbed by acid concentrations of 80-7%. This group embraces the secondary olefines propylene, butene-1, butene-2, and pentene-2 as well as 1,3-butadiene.
- (3) Olefines not absorbed at an appreciable rate by 87% acid, but readily absorbed in more concentrated acid. The only member of this group is ethylene.

The above classification is substantiated by the following experimental data of Davis and Schuler for the relative rates of absorptions of various gaseous olefines in sulphuric

acid of different concentrations at 25° C both in stationary and rotating absorption chambers.

Rates of Absorption Velocities of Different Olefines

Sulphuric acid, % R.F.M. of pipette	95.8		87.0		80.0		70.0		60.0	
	0	28	0	28	0	28	0	28	0	28
Propylene ethylene	238	350	283	350	362					
1-Butene propylene	1.9	3.2	1.8	1.7	1.7	1.8	1.3	0.8		
2-Butene propylene			4.3	3.6	3.9	2.6	3.7	1.4		
2-Butene 1-butene			2.4	2.1	2.3	2.6	2.3	1.7		
Isobutene 2-butene			20.9	18.1	9.2	61.6	36.5	80		

In actual practice the analytical segregation of the various olefines by the sulphuric acid method is best carried out by a series of absorptions for definite times in standardized amounts of sulphuric acid of the requisite concentration, the observed absorption being thus corrected for the slow absorption due to the less reactive olefinic constituents. Thus in the absorption of the olefines of group 1 a series of 5-min absorptions in 63% sulphuric acid is carried out, observations of gas volume being taken over a total absorption period of 25-30 min. The initial rapid absorption, due to isobutene and similar hydrocarbons, is succeeded by a much slower and constant absorption due to propylene, *n*-butenes, and butadiene. If the progress of the absorption is plotted graphically, the actual proportion of group 1 olefines may be determined by extrapolating the straight-line portion of the curve (representing the absorption of the less reactive olefines) to the ordinate axis. Slight variations in the acid concentrations employed do not markedly affect the results obtained. Sulphuric acid concentrations of about 63% have been used for the absorption of isobutene and similar reactive olefines by Dobrynski [15, 1925], Marcovch and Moore [33, 1930], and by Hurd and Spence [23, 1929], although Marcovch and Pigulevski [34, 1932] and Whitmore and Langlois [57, 1932] prefer to employ 68% acid, whereby the time of absorption is materially reduced.

After the removal of isobutene and similar reactive olefines, the olefines of group 2 are similarly absorbed together by more concentrated acid, and here again a series of absorptions for definite intervals of time must be made in order to correct for the slow absorption of ethylene. Although the absorption of propylene in 87% sulphuric acid is stated by Tropisch and von Philippowicz to be complete in 10 min, Manning, King, and Sminatt [32, 1928] consider it desirable to continue the absorption for 20 min with gas measurements at intervals of 5 min each so that a correction can be applied for the slow absorption of ethylene. Sulphuric acid of 87% strength is now generally used for removing olefines of group 2, although Dobrynski used 83-4% and Hurd and Spence recommended 82.4% acid for this purpose. Attempts to apply the sulphuric acid absorption method to the analytical separation of the various olefines of group 2 are unlikely to be successful in view of the data already given. The rates of absorption of 1,3-butadiene, *n*-butenes, and propylene are too close to one another to allow of any such separation.

After removal of all the higher olefines, ethylene may be absorbed in any of the reagents previously described for the estimation of the total olefine content of gaseous mixtures. In connexion with the activation of sulphuric mixtures by the sulphates of nickel and silver, Davys and Quiggle [10, 1930] have shown that addition of these salts to 87% sulphuric acid greatly reduces the effectiveness of the separation of propylene and ethylene in contact with this acid absorbent.

Analysis of Unsaturated Gases by Bromination

Quantitative bromination has been proposed as a method of estimating the total unsaturated content of gaseous mixtures, the amount of bromine combining additively with a given volume of gas mixture being determined by methods similar to those used in the examination of liquid hydrocarbons. Dobrynski [15, 1925] has made use of the Francis reagent for this purpose, the advantage of this solution, which consists of an aqueous solution of potassium bromide and bromate acidified with sulphuric acid, being that bromine is slowly liberated according to the equation

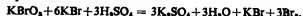

so that the concentration of bromine present in the system can always be maintained at a low value. In the method suggested by Dobrynski, a known volume of gas is introduced into an evacuated flask containing a solution of potassium bromide and sulphuric acid, and a definite weight of potassium bromate is introduced and reaction allowed to take place. Finally, excess bromine is estimated by the addition of potassium iodide solution and titration with standard thiosulphate solution. Bromine addition is said to take place exclusively with the formation of dibromides from monoolefines and tetrabromides from diolefines and acetylenes. However, it has been shown by Davys, Crandall, and Higbee [12, 1931] that the quantitative addition of bromine to diolefines and acetylenes is inhibited by the presence of oxygen, so that these investigators recommend a procedure in which a measured gas volume is introduced into an evacuated vessel containing the bromide-bromate solution, dilute sulphuric acid being run in from a burette until a slight excess of bromine is present. The estimation is then completed in the usual way.

Conversion of unsaturated hydrocarbons into their bromine addition compounds followed by fractionation of the resulting bromides constitutes one of the oldest methods of identifying individual unsaturated hydrocarbons in complex gas mixtures. In this way ethylene, propylene, and butadiene were isolated from 'oil gas' by Armstrong and Miller [1, 1886], while this method has been subsequently employed by several investigators. However, the application of this procedure to the quantitative estimation of individual unsaturated hydrocarbons is rendered difficult by the simultaneous occurrence of side reactions, including substitutive bromination and, in some cases, elimination of hydrogen bromide from the unstable olefine dibromides first formed. Nevertheless, undesirable side reactions may be minimized by controlled bromination at low temperatures, so that, in spite of its inherent disadvantages, the conversion of unsaturated hydrocarbons into their bromides undoubtedly constitutes an investigative method of proved value.

A method of analysis of the gaseous products of coal carbonization has been advanced by Manning, King, and Sminatt [32, 1928] depending upon the formation of bromine addition compounds. Thus the bromine addition compounds obtained by passing about 10 cu ft of gas through two 2-litre Woolf bottles, cooled in a freezing mixture of ice and salt and each containing 25-75 ml of bromine covered with 100 ml of a 10% aqueous solution of potassium bromide, are washed with dilute caustic soda solution, then with water, separated, and weighed. The mixture is then subjected to distillation under reduced pressure to yield the following fractions

(a) Boiling up to 80° C. at 20 mm., this fraction contains

- all the ethylene and propylene dibromides and the major part of the butylene dibromides
- (b) Boiling at 80–130° C under 20 mm, this fraction contains the remaining butylene dibromides and bromine derivatives of higher olefines
- (c) Residue, consisting mainly of butadiene tetrabromides

Known weights of fractions (a) and (b) are then treated with the zinc-copper couple in alcoholic solution, and the liberated olefines are examined by the usual absorption and combustion procedures. The residue, (c), contains two forms of butadiene tetrabromide which are present in approximately equimolecular proportions. Since the higher melting form is scarcely soluble in cold alcohol, it can be recovered from (c) by extraction with boiling alcohol followed by cooling the filtered solution to 0° C. The deposited crystals are weighed and the butadiene content can then be calculated, assuming that only 50% of the total butadiene tetrabromides are recovered in this way.

Special Methods for the Estimation of Olefines of Four Carbon Atoms

Hurd and Goldsby [22, 1934] have drawn attention to a sensitive and selective test for isobutene, which depends on the formation of an orange turbidity or precipitate in the presence of the reagent discovered by Denigès [13, 1898]. The reagent is prepared by heating a mixture of 20 g of mercuric oxide in 100 ml of water with 40 ml of concentrated sulphuric acid, the solution being diluted with water to 400 ml. When passed into this reagent, isobutene gives a yellow turbidity, which increases on warming, while boiling the solution causes the separation of a heavy orange precipitate. Although the other butenes dissolve in this reagent, no precipitate is formed on warming, while trimethylethylene also does not give the test. The possibility of extending this remarkable reaction to the quantitative estimation of isobutene in gas mixtures is indicated by the work of Hurd and Goldsby. Various procedures for the determination of the proportions of the three isomeric *n*-butenes (i.e. butene-1, *cis*-butene-2, and *trans*-butene-2) have been elaborated on the basis of conversion of mixtures of these hydrocarbons into their dibromides. Bromination of such a mixture is best carried out at low temperatures, the addition of bromine being finally completed after allowing to warm to room temperature. In order to determine the proportion of butene-1 in admixture with the other *n*-butenes, Frey and Yant [18, 1927] suggest bromination followed by heating the mixed dibromides with 15% alcoholic potassium hydroxide in a sealed tube at 100° C for 2–5 hours. Under these conditions 1,2-dibromobutane only is converted to the extent of 51% into ethylacetylene, which may be readily estimated in the form of its silver derivative.

Attempts to develop an analytical method for estimating the relative proportions of *n*-butenes in mixtures of these hydrocarbons by careful fractionation of their dibromides have proved unsuccessful [29, 1930], but Dillon, Young, and Lucas [14, 1930] have been able to devise a method based on the different reaction rates of these dibromides with potassium iodide in methanol solution at 75° C. For details of this somewhat complicated method the original papers should be consulted.

Butadiene is most conveniently recognized as its characteristic tetrabromide, m.p. 118° C. A lower melting stereoisomeric tetrabromide is also formed so that methods of analysis based upon determinations of the weight of the

higher melting bromide formed from a given volume of gas can only be accurate if the ratio of these isomers produced under given conditions is accurately known. Values for the butadiene content of gas mixtures obtained by weighing the crude mixtures of tetrabromides remaining after removal of admixed volatile olefine dibromides by vacuum distillation are likely to be too high on account of the presence of other non-volatile bromination products [34, 1932]. The titrimetric bromination methods have been found unsatisfactory for the determination of butadiene except in the case of highly rectified butene-butadiene condensates [34, 1932]. Methods have been advanced for the determination of butadiene in the form of its tetrachloride by Sorokin and Belikova [48, 1925] and as its dihydrochloride by Ostromusslenski [36, 1915], but have found no general application. More recently Tropch and Mattox [52, 1934] have described a very convenient volumetric method of analysis of butadiene depending upon the rapid absorption of this gas in molten maleic anhydride at 100° C to form a non-volatile addition compound. The apparatus used by these investigators consisted merely of a gas burette for gas measurement at constant pressure and a small bead-packed absorption vessel, containing 2–2.5 g of maleic anhydride and maintained at 100° C by means of a boiling-water bath. In order to minimize errors due to physical solution of other hydrocarbons it was necessary to employ the minimum of maleic anhydride and to first saturate the absorbent with the hydrocarbons by a preliminary treatment with a sample of the gas under investigation. Tropch and Mattox showed that olefines and acetylene, the latter in concentration up to 15%, did not interfere with this method. However, maleic anhydride is a specific reagent for conjugated diolefines and rapidly absorbs isoprene, cyclopentadiene, and dimethylbutadiene. The application of this method to the estimation of butadiene and similar conjugated diolefines in coal gas has been described by Gooderham [20, 1937], who, however, obviated difficulties due to physical solution of non-diolefinic hydrocarbons by evacuating the absorption pipette both before and after absorption. The absorption of butadiene in maleic anhydride at 100° C is said to be complete in 12 min. at atmospheric pressure, although other conjugated diolefines react more rapidly.

Estimation of Helium in Natural Gases

Methods for the estimation of the helium content of natural gases are based on the observation that all gases, except neon and helium, are adsorbed by active charcoal at the temperature of liquid air. The apparatus usually employed for this analysis consists of a series of condensation vessels, cooled in liquid air, in which all hydrocarbon constituents, except small amounts of methane, are liquefied. The residual gas is then introduced into an evacuated bulb containing charcoal, previously degassed at elevated temperatures, the bulb being cooled in liquid air. Under these conditions all gases except neon and helium are completely adsorbed. The helium and neon may then be pumped into a burette for volume measurement and for spectroscopic examination. In the removal of the helium and neon, pumping to a low pressure is essential, since charcoal at liquid-air temperature adsorbs appreciable quantities of helium (about 2.5 ml. per g. of charcoal at atmospheric pressure). A relatively simple apparatus for carrying out helium determinations has been described by German, Gagos, and Nelson [19, 1934], who have also furnished an excellent literature summary of this subject.

REFERENCES

- 1 ARMSTRONG, H E., and MILLER, A K *JCS* 49, 74 (1886)
- 2 BLAIR, E W., and WHEELER, T S *JSCI* 41, 187r (1922)
- 3 BOMBCHART, R A *J Ind Eng Chem Anal Ed* 6, 29 (1934)
- 4 BOYD, J H., and OBERSEIDER, J L *Ind Eng Chem Anal Ed* 3, 123 (1931)
- 5 BURELL, G A., SEIBERT, F M., and ROBERTSON, I W U S Bureau of Mines, Tech. Paper, no 104 (1915)
- 6 California Natural Gasoline Association Bull TS-321
- 7 CAMPBELL, J R., and GRAY, T *JSCI* 49, 432t, 447t, and 450t (1930)
- 8 DAVIS, H S *Ind Eng Chem Anal Ed* 1, 61 (1929)
- 9 DAVIS, H S., and DAUGHERTY, J P *Ind Eng Chem Anal Ed* 4, 193 (1932)
- 10 DAVIS, H S., and QUIGGLE, D *Ind Eng Chem Anal Ed* 2, 39 (1930)
- 11 DAVIS, H S., and SCHULFR, R *JACS* 52, 721 (1930)
- 12 DAVIS, H S., CRANDALL, G S., and HIGGINS, W E *Ind Eng Chem Anal Ed* 3, 108 (1931)
- 13 DÉNGHÉ, G *Compt rend* 126, 1043 (1898)
- 14 DILLON, R J., YOUNG, W G., and LUCAS, H V *JACS* 52, 1953 (1930)
- 15 DOBRYANSKH *Neft Khoz* 9, 565 (1925)
- 16 ERDMANN, E., and STOLTZENBERG, H *Ber* 43, 1702 (1910), STOLTZENBERG, H *ibid* 43, 1708 (1910)
- 17 FITCH *Nat Petr News*, 23, 66 (1931)
- 18 FREY, F E., and YANT, W P *Ind Eng Chem* 19, 488 and 492 (1927)
- 19 GERMANN, F E E., GAGOS, K A., and NELSON, C A *Ind Eng Chem Anal Ed* 6, 215 (1934)
- 20 GODDARDHAM, W J *JSCI* 56, 32r (1937)
- 21 GRICE and PAYMAN *Fuel*, 3, 236 (1924)
- 22 HURD, C D., and GOLDSBY, A R *JACS* 56, 1812 (1934)
- 23 HURD, C D., and SPENCE, L U *JACS* 51, 3356 (1929)
- 24 KING, J G *Fuel*, 1, 103 (1922)
- 25 KING, J G., and EDGECOMBE, L J Fuel Research Tech Paper no 13 (1931)
- 26 KUHN, G *Z angew Chem* 44, 757 (1931), cf PETERS, VON K., and WEIL *Z physik Chem* 148A, 1 (1930), PETERS, VON K., and LOHMAN, W *Brenn-Chem* 18, 41 (1937)
- 27 LEBEAU, P., and DAMINIS, A *Ann Chim* 8, 221 (1917), LEBEAU, P., and BEDEL *Ber* 37, 772 (1924)
- 28 ——— *Compt rend* 156, 325 (1913)
- 29 LUCAS, H J., DILLON, R T., and YOUNG, W G *JACS* 52, 1949 (1930)
- 30 MACGILLIVRAY, W E *JCS* 941 (1932)
- 31 McMILLAN, W A *JIPT* 22, 616 (1936)
- 32 MANNING, A., KING, I., and SINNATT F Fuel Research Tech Paper no 19 (1928)
- 33 MARCOVICH, M B., and MOORE, B G *Nat Petr News*, 23, no 41, 33 (14 Oct 1931), *ibid* 23, no 42, 27 (21 Oct 1931), MARCOVICH, M B., MOORE, B G., and DEMENTIWA *Neft Khoz* 19, 604 (1930)
- 34 MARCOVICH and PIGULEVSKI *Refiner*, 11, 259 (1932), *ibid* 11, 260 (1932)
- 35 MICHAEL and BRUNEL *Amer Chem J* 41, 118 (1909)
- 36 OSTROMISLENSKI *J Russ Phys-Chem Soc* 47, 1983 (1915)
- 37 PAAL, C., and HARTMANN, W *Ber* 43, 243 (1910), *Bret Fuel*, 7, 45 (1928), HAGUE, E N., and WHEELER, R V *Fuel*, 6, 560 (1929)
- 38 PODBIELNIAK, W J *Ind Eng Chem Anal Ed* 3, 177 (1931), *ibid* 5, 119 (1933), *Oil and Gas J* 38 (17 Jan 1929), *ibid* 30 (16 May 1929), *ibid* 235 (2 Oct 1930), *ibid* 22 (4 May 1931), *Refiner*, 8, no 3, 55 (1929), *Petr World*, 14, 102 (1929)
- 39 ——— *Oil and Gas J* 68 (31 March 1932)
- 40 RIEBE, W *Z angew Chem* 44, 701 (1931)
- 41 ROSEN, R., and ROBERTSON, A E *Ind Eng Chem Anal Ed* 3, 284 (1931)
- 42 ——— *Ind Eng Chem Anal Ed* 6, 12 (1934)
- 43 SCHAUFELBERGER *Oil and Gas J* 46, 163, and 167 (4 Sept 1930)
- 44 SCHULTZE, G R *Z angew Chem* 45, 573 (1932)
- 45 SHEPHERD, M Bureau Standards J Research, 2, 1145 (1929), U S Bureau Standards Research Paper 75 (1929)
- 46 ——— Bureau Standards J Research, 6, 121 (1931)
- 47 SHEPHERD, M., and FORSTER, F *Ind Eng Chem* 15, 1143 (1923)
- 48 SOROKIN and BELKOVA *J Ind Chem (Russian)*, 1, 28 (1925)
- 49 TRAVERS, M W *The Experimental Study of Gases* (1901)
- 50 TROPSCH, H., and DITTRICH, E *Brenn-Chem* 6, 169 (1925)
- 51 TROPSCH, H., and MATTOX, W J *Ind Eng Chem Anal Ed* 6, 235 (1934)
- 52 ——— *Ind Eng Chem Anal Ed* 6, 104 (1934)
- 53 ——— Paper read before Production and Chemical Committees of Amer Gas Association, New York City (May 1934), Universal Oil Products Booklet no 138 (1934)
- 54 TROPSCH, H., and von PHILIPPOVICH, A *Brenn-Chem* 4, 147 (1923)
- 55 VANDANVEER *Amer Gas Assoc Proc* 1043-6 (1931)
- 56 VAN DYCK, W J D *JIPT* 16, 145 (1932)
- 57 WHITMORE, F C., and LANGLOIS, D P *JACS* 54, 3445 (1932)

THE UTILIZATION OF LIQUEFIED PETROLEUM GASES

By G. G. OBERFELL and T. W. LEGATSKI

Phillips Petroleum Company

The possibilities of creating markets for large quantities of liquefied petroleum gases were visualized many years ago, but the extensive development of these potential outlets awaited the solution of the many technical problems having to do with the manufacture, transportation, and utilization of the product and the formulation and execution of plans pertaining to the merchandising of the commodity. Developments along these lines were greatly accelerated by the economic pressure exerted by ever-increasing supplies of raw material for the manufacture of such products.

A conception of the economic and technologic changes which have been taking place in the natural gasoline, petroleum-refining, and automotive industries is necessary in order to properly understand the ever-increasing potential supplies. A brief summary of these changes will be helpful.

Natural gasoline, a product extracted from natural gas, has long been advantageously used to blend in small quantities with refinery gasoline to make a finished motor fuel. In past years the rapid growth of the automotive industry taxed the ability of the petroleum industry to keep pace with the demand for motor fuel. Consequently, refiners were prone to 'cut' deeper into the crude oil in order to produce from each barrel increasing amounts of a product which might pass as motor fuel. Blending with small quantities of light natural gasoline to improve the starting characteristics of such fuels was common practice. In order to secure proper vaporization of this fuel, automotive designers were forced to embody various types of manifold heaters in their fuel-induction systems during this period. The ever-increasing demand for motor fuel next caused the refiners to concentrate on the development of cracking processes, and the progress made in this field of endeavour brought with it a large supply of gases from which a product similar to natural gasoline could be recovered. The increasing demand for motor fuels of improved anti-knock characteristics also supplied a powerful incentive to the more extensive application of cracking.

Coupled with the over-production of crude oil of recent years, the increased oil-cracking capacities at refineries created a supply of the highly volatile constituents of gasoline greatly in excess of that which could be successfully used in motor fuel without encountering vapour-locking difficulties in the fuel feed system of the automobile. It was, therefore, found necessary to reduce the volatility of the natural gasoline used in motor fuel, and this was accomplished by removal of practically all the propane and a large portion of the butane from natural gasoline. This step furnished the necessary impetus to natural gasoline manufacturers to develop the liquefied gas markets for propane and butane because of the immediate availability of these products. Through the expansion of their oil-cracking facilities and the installation of more efficient vapour-recovery systems, many refiners are now finding themselves similarly situated with an excess supply of propane and butane. Hence large refineries, when favourably located with respect to markets, now constitute a second important source of supply.

Many independent estimates have been offered as to the potential supply from both of these sources. The potential supply of butane alone was estimated early in 1934 as being approximately 250,000 bbl per day. Approximately one-quarter of this amount finds its way into motor fuel. With continued improvement in automobile fuel-system design, it is expected that eventually half of the currently available supply may find its way into motor-fuel channels. This still leaves available for other uses at least 125,000 bbl per day plus such additional supplies as may be created through more extensive applications of the cracking processes.

The potential propane supply, although considerably greater in quantity, is nevertheless more difficult to predict with any great degree of accuracy. There is reason to believe that the potential propane resources of the United States are approximately 500,000 bbl per day. Since present extraction practices are such that the economical recovery is limited to about 25%, the potential figure is immediately reduced to around 125,000 bbl per day. Of this amount probably at least half exists at plants too small to be considered for economical extraction or in localities too far removed from potential markets. The remainder, approximately 60,000 bbl per day, is available, and this amount could undoubtedly be increased by further modifications in the extract.

Method of Extraction

Although a variety of methods are in use, the most widely accepted process for recovering propane and butane is one of a number of steps comprising absorption from the gas, recovery of the absorbed material from the absorbent by distillation, chemical treatment of the recovered material, and lastly a series of fractional distillation steps for the purpose of segregating the several finished products.

The absorbent used is a narrow boiling-range oil of about 200 mol wt. This is circulated through absorption towers or scrubbers of the bubble-plate type in quantities calculated to effect the proper degree of removal of the constituents desired from the gas. Since most refineries have vapour-recovery plants similar in design to natural gasoline plants, the extraction of the propane and butane may be considered as a by-product operation of the manufacture of natural and vapour-recovery gasoline.

The quantity of low molecular weight hydrocarbons contained in the saturated absorbent along with the natural gasoline or vapour-recovery plant gasoline varies with the conditions of temperature, pressure, and oil circulation rate under which the absorption was conducted. The absorbed materials are removed from the absorbent oil by distillation, and are later rectified to separate the vapour recovery or natural gasoline. In present commercial practice the gasoline thus made contains butane in amounts varying from traces to as high as 30% by volume, depending upon the seasonal requirements of the refinery product in which it eventually is blended.

The excess butane from the above rectifying operation, together with propane and lighter gases, constitutes the raw material for liquefied gas manufacture. Since this material

in most cases contains hydrogen sulphide, mercaptans, and other organic sulphur compounds in appreciable quantities, a chemical treatment is necessary at this stage. The treatment usually takes the form of a caustic wash for the purpose of removing hydrogen sulphide and some of the mercaptans, followed by a hypochlorite wash. These operations are finally followed by a thorough water wash.

The treated feed stock free of mechanically entrained water is pumped to the first of a series of two fractionating towers, where a separation is effected between the butanes and the propane and lighter fractions. The bottom product of this operation is finished butane. The top product, after being completely condensed, is run to a separating vessel, where a water layer separates and is periodically drawn off. The hydrocarbon layer is pumped to the second column, where a separation is made between propane-propylene and the lighter constituents. The nature of this separation is such that it should be conducted at low condenser temperatures (about 40° F) if high recoveries of saleable product are to be realized. When this distillation step is conducted with proper care, the bottom product will always be sufficiently dehydrated for bottled-gas use and will also be an acceptable product in every other respect.

Properties of Liquefied Petroleum Gases

The materials classified as commercial liquefied petroleum gases in general fall into two more or less distinct grades, known as propane and butane. The number of grades are, however, by no means limited, since the classification is a loose one. Source of raw materials, the purpose, and the details of utilization all play an important part in determining the product characteristics. Although there are two sources of supply, natural gasoline plants and refineries, the materials are so similar that they may be used interchangeably in most applications. The properties of the major products as affected by their sources will be briefly considered, followed by a discussion of the requirements imposed on the products by the use for which they are intended.

The liquefied gas raw material from natural sources is a somewhat uncertain mixture consisting primarily of propane, *iso*-butane, and normal butane, as well as small percentages of ethane and pentane. Depending upon the locality, such products also may contain appreciable quantities of hydrogen sulphide and the various organic sulphur compounds of comparable boiling-points. In the course of refining this material a fairly uniform product containing 95-9% propane can normally be produced. The composition of the concurrently produced butane fraction will be much more variable, depending upon the amount of normal butane which was removed from the original raw material with the light gasoline for incorporation in motor fuel. Variations in composition of from traces to 10% in propane, 10-70% in *iso*-butane, 30-90% in normal butane, and from traces to 3% in pentane contents have been observed in some instances. However, the average product of the manufacturing operation normally contains about 5% of propane and from 20-30% of *iso*-butane, the balance being normal butane. Fortunately, the properties and the behaviour of the constituents which vary most widely in their occurrence are so similar that they can be wholly disregarded in the use of the product as a fuel. The sulphur content of the treated products is very low, being of the order of 2-12 grains per 1,000 cu. ft. of vaporized material. On a thermal basis

the sulphur content would be equivalent to that of a 550 B Th U. gas containing less than 2 grains per 1,000 cu. ft.

The raw material for liquefied gases from refinery sources is much more variable than that from natural sources, since the composition is affected very materially by the magnitude and type of cracking operations practised. As would be expected, such a raw material contains not only the hydrocarbons of the paraffin series, but also the various olefinic derivatives. The percentage of olefines in the mixture appears to vary from 10% to as high as 40%. Here, again, it is fortunate for the fuel user that the olefines resemble the paraffins so closely in all their important combustion characteristics. The concentration of sulphur compounds in the refinery raw material is usually somewhat higher than in the natural raw material, but experience has shown that proper treatment will give products comparable to the natural products.

The intended use and the method of utilization place some important restrictions on the permissible range in composition of the products. Experience has quite definitely shown that the bottled-gas grade of liquefied gas must contain approximately 95% propane or propylene if uniformly good results are to be had under all climatic conditions. This grade of material must also be used in all larger scale operations where vaporization is to be accomplished by batch distillation from the storage vessel. The second important requirement in the case of such a product is that it be at least partially dehydrated. If not sufficiently dehydrated, considerable trouble will be experienced with ice forming in the pressure-regulating equipment when the atmospheric temperatures approach the freezing-point of water. The third requirement is that the product be substantially non-corrosive to avoid deterioration of the equipment. Because these gases are practically odourless, it is now becoming quite common practice for manufacturers to add small percentages of highly odiferous materials to the finished product in order to minimize hazards occasioned through leakage in equipment or appliances. Ethyl mercaptan is probably the most widely used odorant for this purpose. A very important requirement for a suitable bottled-gas odorant is that it shall be sufficiently volatile so as not to result in a building-up of residues in the batch distillation process. Average characteristics of bottled-gas grade propane are presented in Table I.

Commercial butane has its largest ultimate use in a diluted form and it can, therefore, be regarded primarily as an enriching medium. The chief requirements of an enriching medium are that it be reasonably consistent in heating value and that it be free of more than traces of heavier materials which might introduce complications in the vaporization process. Experience with various types of vaporizers has indicated that the maximum amount of material of higher boiling-points than butane which can be satisfactorily handled is somewhere in the range 2-5%. The actual amount is, of course, dependent upon the nature of the heavy material, the type of vaporization apparatus employed, and the enriching practices that are followed. Barring this restriction, the hydrocarbon composition can vary within wide limits in enrichment applications, since even appreciable quantities of propane do not materially affect the heating value. For industrial applications the product normally consists of about 90% butanes and butylenes. Although large quantities of sulphur could readily be tolerated in butane used for enrichment purposes, the average amount present after proper chemical treatment to remove the more corrosive forms of sulphur

is so low as to be insignificant. Table I gives the average characteristics of butane intended for industrial or enrichment use

TABLE I
Average Properties of Liquefied Petroleum Gas Products

	Commercial propane	Commercial butane
Vapour-pressure lb per sq in gauge		
at 70° F	124	31
at 50° F	167	69
at 100° F	192	59
at 105° F	206	65
at 150° F	286	97
Specific gravity of liquid (60°/60° F)	0.509	0.582
Inflated boiling-point at 14.7 lb per sq in abs * F	-51	15
Weight per U S gallon of liquid at 60° F, lb	4.24	4.84
Mean coefficient of thermal expansion, liquid		
50-100° F	0.00145	0.00104
0-100° F	0.00186	0.00122
Dew-point at 14.7 lb per sq in abs, * F	-46	24
Specific heat of liquid, B Th U per lb per * F at 60° F	0.588	0.549
Cu ft of gas at 60° F, 30 in Hg per U S gallon of liquid at 60° F	36.28	31.46
Specific volume of gas, cu ft per lb at 60° F, 30 in Hg	8.55	6.50
Specific heat of gas, B Th U per lb per * F at 60° F (C _p)	0.404	0.382
Specific gravity of gas (air = 1) at 60° F, 30 in Hg	1.52	2.01
Ignition temperature in air, * F	920-1,020	900-1,000
Maximum flame temperature in air, * F	3,595	3,615
Per cent gas in air for maximum flame temperature	4.2-4.5	3.3-3.4
Maximum rate of flame propagation in 25 mm tube		
cu per sec	84.9	87.1
in per sec	33.4	34.3
Limits of inflammability in air, gas per cent in gas-air mixture		
at lower limit, %	2.4	1.9
at maximum rate of flame propagation, %	4.7-5.0	3.7-3.9
at upper limit, %	9.6	8.6
Required for complete combustion		
cu ft O ₂ per cu ft gas	4.9	6.3
cu ft air per cu ft gas	23.4	30.0
lb O ₂ per lb gas	3.60	3.54
lb air per lb gas	15.58	15.3
Products of complete combustion		
cu ft CO ₂ per cu ft gas	3.0	3.9
cu ft H ₂ O per cu ft gas	3.8	4.6
cu ft N ₂ per cu ft gas	18.5	23.7
lb CO ₂ per lb gas	3.0	3.1
lb H ₂ O per lb gas	1.6	1.9
lb N ₂ per lb gas	12.0	11.8
ultimate CO ₂ , % by volume	13.9	14.1
Latent heat of vaporization at boiling-point		
B Th U per lb	185	167
B Th U per U S gallon	785	808
Total heating values (after vaporization)		
B Th U per cu ft	2,522	3,261
B Th U per lb	21,560	21,180
B Th U per U S gallon	91,500	102,600

In addition to the basic products discussed above, products of almost every description are available for less or for more exacting applications. These products range from the pure hydrocarbons themselves to mixtures of every conceivable composition. The basic products previously described constitute by far the greater percentage of the output

Handling and Transportation

Propane, butane, and the various intermediate grades of liquefied petroleum gases are handled from the time of manufacture in much the same manner as other less volatile liquids. The products are transferred by maintaining pres-

sure differentials on the containing vessels or by means of specially designed transfer pumps

Storage tanks used at the point of manufacture are most commonly of about 15,000 gallons capacity. Such tanks are designed and built in accordance with specifications of the American Society of Mechanical Engineers for unfired pressure vessels. Propane tanks are usually built for a working pressure of 200 lb per square-inch gauge, and butane tanks for a working pressure of approximately 80 lb per square inch.

The products are transported by rail in I C C cylinders, or in tank cars approved for the purpose, and by highway in cylinders and tank trucks. Water shipment in specially constructed tank ships has also been resorted to, and in at least one instance pipeline transportation has been used with success.

At the point of use storage tanks are installed either above or underground as the soil conditions or space limitations may require. The valves, gasket material, liquid-level gauging devices, thermometers, and other tank appurtenances are of those types especially designed for liquefied gas service. Detailed descriptions of the arrangements most commonly used are to be found elsewhere in the literature.

Two general systems are employed to vaporize the product at the point of consumption. The first of these, which is applied to propane where the rate of withdrawal is not excessive, is one of batch distillation from the storage vessel. Since the necessary latent heat of vaporization in such instances is atmospheric heat which must flow through the walls of the containing vessel to the body of liquid in the vessel, it is needless to remark that it can only be used where the latent heat requirements are not large and are not subject to wide variations. Such vessels can, however, be fitted with auxiliary heating coils to take care of greater requirements. The vaporized propane leaves a tank through either a single or series of pressure-reducing regulators which are set to maintain whatever pressures are necessary on the distribution system. The nature of the gaseous product makes it feasible to pipe it anywhere without fear of condensation difficulties. Hence it is frequently piped to various locations in industrial plants at pressures as high as 30 lb for utilization in special types of insulating equipment. Similar practice is followed in distribution systems for small towns with service regulators to reduce further the pressure at the consumers' premises.

The second system of vaporization which is much more widely employed is one of flash vaporization. Butane and also mixtures of butane and propane are used through such systems, since fluctuations in heating value are thereby eliminated. If the equipment in such an installation is designed for the maximum requirements, sudden peak loads may readily be handled. Because of the great flexibility of this system, it has even been applied to propane in preference to the batch distillation system, particularly in the larger installations. In brief, this system consists of a line from the liquid storage tank through which the liquid flows to a pressure-reducing regulator. From the discharge side of the regulator the liquid flows at from 5-10 lb. pressure to the vaporizing apparatus. The vaporizers used are of various types in which steam or hot water constitute the heating medium. Vapours pass from the top of this apparatus through a series of pressure regulators which reduce and maintain the pressure at the desired level. The amount of liquid passing to the vaporizing apparatus is controlled by the pressure on the vaporizer which, in turn,

is subject to the demand for vapours. With lines properly insulated or otherwise protected, the vapours may be handled in the undiluted state for considerable distances. However, in instances where it is intended eventually to use the vapours as a partial or as a total pre-mix with air, it is customary to locate the proportioning equipment close to the vaporization apparatus. When this is done the pre-mixed gas may be piped anywhere without fear of condensation difficulties, since the dew-point temperature of the mixed gas is lower than temperatures commonly encountered in distribution systems.

Competitive Position of Liquefied Petroleum Gases

Liquefied petroleum gases are being used in a number of ways at the present time, and the possibilities are that other applications will be developed in the future. Utilization is classified into four major groups, based on the methods of distribution and application of these hydrocarbons, and are as follows:

- 1 Direct gas service in which the undiluted gases are employed.
 - (a) Individual domestic distribution in cylinders
 - (b) Community distribution in pipelines
 - (c) Industrial use
- 2 Gas enrichment or cold carburetion
 - (a) Enriching water gas, blue gas, or other gases of low thermal value to meet calorific standards
 - (b) Recarburetion to offset thermal loss due to compression and transmission of manufactured gas
- 3 Base material for manufacturing gas
 - (a) Meeting peak-load conditions
 - (b) Reforming to produce a low-gravity gas of high thermal value
 - (c) Propane-air and butane-air carburetion
- 4 Special uses
 - (a) Solvents, extraction mediums
 - (b) Dewaxing of lubricating oils
 - (c) Refrigeration
 - (d) Base for organic chemicals
 - (e) Fuel for internal-combustion engines
 - (f) Welding and metal-cutting operations

The competitive position of liquefied petroleum gases in the first three groups listed above is immediately obvious when a comparison is made of various fuels. Although ideal materials are often regarded as imaginary or impracticable, all engineers recognize certain characteristics of an ideal fuel. Such a fuel must be gaseous so as to be easily handled, transported, and controlled, and to permit a maximum quantity of heat to be released in a minimum combustion space in the shortest length of time. It must be free from foreign or deleterious substances and from corrosive constituents. It must have combustion characteristics that adapt it to the multitudinous demands of hundreds of industries and thousands of processes. It must be uniform and unchanging in composition to ensure like results under like conditions. It must be generally available and in practically unlimited quantities, regardless of the point of use. It must possess flexibility and universal adaptability, and it must be economical in use. Such a fuel naturally will produce results superior to those obtained with ordinary fuels and, therefore, will find a large and universally acknowledged place in industry.

Practically every one will concede that natural gas most nearly fills these requirements. However, it is not available generally and the supply is not always adequate. Coal has availability, distribution, and economy in its favour, yet one recognizes its limitations for the higher classes of thermal processing, upon calling to mind the enormous investment and the high capital and operating costs involved in converting it to coke, to coal gas, and to water gas, and other more adaptable and, therefore, more valuable classes of fuel. Producer gas has its serious limitations, coal-gas production lacks the flexibility demanded by industry, and water gas usually requires carburetion. All these gases are inherently variable in composition, specific gravity, and calorific value. In practice these handicaps are minimized by judicious mixing in holders or by frequent adjustment of the combustion apparatus in use.

Oil is generally available and is usually less costly per unit of heating value than the higher forms of fuel evolved from coal, but it suffers by comparison with such fuels. It is not gaseous, it requires a large volume of combustion space, it is variable in quality, and its precise control offers difficulties.

Liquefied petroleum gases are competitive in one application or another with practically every type of fuel being used to any extent at the present time. They have all the advantages of a gaseous fuel—cleanliness, convenience, heating efficiency, ease of handling, accuracy of control, and at the same time they possess the principal advantage of the solid and liquid fuels in that they can be made available for use anywhere. Long-range transportation is simplified because they are shipped as liquids. Short-range transportation is convenient because they are used as gases.

Utilization of Liquefied Petroleum Gases

A complete description and analysis of each of the various uses previously outlined would be beyond the scope of this article. Consequently, the major uses will be but briefly described.

Individual Domestic Distribution in Cylinders.

As early as 1912 liquefied petroleum gases were used for cooking and hot-water heating purposes, although the adoption of this fuel did not become general until tank-car methods of transportation of the commodity were perfected. The decrease in transportation costs made bulk-station facilities possible, and this has resulted in rapid development. Since that time the number of consumers has been constantly growing until at the present time the number in the United States is estimated at near 250,000. Although no accurate figures are available, the use of bottled gas in Europe and in northern Africa has been reported as rapidly increasing.

Two methods of 'bottled-gas' service are commonly employed. The first of these, known as the One-drum System, consists of a single cylinder or tank containing approximately 90 days' normal fuel supply which is permanently installed on the customer's premises. The cylinder is periodically refilled by means of a tank truck, the cylinder being weighed before and after the refilling operation. The amount of fuel consumed is readily determined from the differences in weight. A more commonly employed system, known as the Two-drum System, consists of two cylinders manifolded together so that when one cylinder is empty, the other can be turned on, and in this way practically uninterrupted gas service is obtained. The

empty cylinder is collected by the fuel distributor and refilled at the bulk-station charging plant

The approximate cost of equipment for a Two-drum installation is as follows

1 cabinet	\$10 50
2 cylinders	16 00
1 regulator	4 50
2 valves	2 30
Manifold, piping &c	6 65
Total	\$39 95

The cost of a complete One-drum unit is somewhat lower, being approximately \$26. However, offsetting this lower cost is the higher cost of truck-delivery equipment. Hence, for servicing scattered customers over a wide area the Two-drum System is undoubtedly the most economical. The One-drum System will find its chief application in thickly settled suburban areas where trucking costs will be low.

The price at which propane is customarily sold to the domestic consumer is from a minimum of 4 to a maximum of 14 cents per pound, from which it is self-evident that it is not competitive with natural gas or even with manufactured gas at prevailing average rates. This difference in cost in reality amounts to a service charge which the users pay for gas convenience beyond the gas mains. This retail price is such that it is more economical for cooking and water-heating purposes than electricity at prevailing rates.

Community Distribution in Pipelines.

A survey conducted a few years ago in the United States showed that there were hundreds of communities between 1,000 and 2,500 population, and an appreciable number over 2,500 population without gas service. The total gas required for any of these communities is small. The load factor is very apt to be extremely low, hence supplying these towns with gas through transmission lines economically is often quite out of the question, inasmuch as the fixed charges would be prohibitive. Liquefied gases in many instances have furnished the solution to this problem in the form of so-called undiluted vapour plants.

In this system a central storage tank of from 10,000 to 15,000 gallons capacity is periodically filled with propane shipped by tank car. In localities where the climate is more mild a mixture of propane and butane is sometimes used. Propane being self-vaporizing at all temperatures above minus 44° F obviates the necessity of a vaporizer, so that the plant equipment is reduced to a liquid storage tank, regulators, and a station meter. The propane vapour is withdrawn from the top of the tank.

The pressure is reduced in two stages first, by means of a ratio-type regulator located on the vapour line at the liquid storage tank which maintains a reduced pressure proportional to the tank pressure. This prevents the possibility of any liquid condensation in the vapour line leading from the tank to the regulator and meter house. The final regulation to the pressure carried on the distribution system is obtained by a conventional-type regulator. The gas is metered on the downstream side of the regulator before entering distribution mains, which usually operate at from 1-5 lb., with individual house governors ahead of the customers' meters. The distribution system normally consists of 2-in., 1½-in., and 1-in. mains.

Modifications of this system to handle groups of still smaller towns are possible. The central stations necessary in this system are also employed for recharging cylinders used in the various bottled-gas systems.

Industrial Use.

While liquefied petroleum gases are generally applicable to any industrial heating process to which any other fuels can be applied, this discussion will consider only those applications which have so far been the most common.

For heating operations such as annealing, normalizing, hardening, drawing, cyaniding, and similar heating work, and for soft-metal melting, carburizing, vitreous enamelling, galvanizing, smelting, malleabilizing, &c., propane and butane are ideal fuels because of their purity, high combustion efficiencies, and their uniform physical characteristics. Automatic proportioning equipment of the variable or fixed orifice type have proved very satisfactory for use with the undiluted gases. These types will operate equally satisfactorily with partial butane-air mixtures of 600-800 B.Th.U. values. With this equipment it is interesting to note that the initial heating-up time is usually reduced about 50% as compared to the time required with city gas, due to higher burner-manifold pressures obtained with a given air pressure to the inspirator.

Liquefied petroleum gases are excellent fuels to be used with 'radiant' and 'diffusion' flame burners on forging and other high-temperature heating operations because of the high percentage of carbon present in the molecule as compared to city gas and natural gas. Propane contains about 82% carbon by weight, and natural gas (methane) 75% carbon. The combustion of propane or butane can be so regulated as to produce free carbon in the flame. The free carbon becomes incandescent before the combustion reaction is entirely completed, thus providing a radiant flame from which the heat is transferred by radiation directly to the material being heated, giving equally as rapid, if not more rapid, heating up than is possible with the use of fuel oil. Several commercial applications using propane or butane for forging with 'radiant' and 'diffusion' flame burners are now successfully operating in the plants of automotive parts manufacturers. The relative absence of scale on the stock in the billet heater is an outstanding feature of these operations. The value of this absence of scale cannot be over-estimated as many indirect but tangible advantages result, such as longer die life, a minimum of metal loss, material reduction in machining costs, and a minimum of rejections.

It may be noted further that increased production per furnace, i.e. more pounds heated per square foot of hearth area, and longer life of furnace refractories, result with this method.

For oven-heating operations, such as drying, japanning, enamelling, burn-off, core baking, and the like, propane and butane have proved to be very satisfactory. They are flexible, clean, easy to handle, and form products of combustion free of injurious products such as sulphur compounds, dust, tars, or gums. On this type of work these gases are burned in various appliances. Both direct and recirculating or indirect air heaters equipped with low-pressure inspirator automatic proportioning equipment are used with air pressure at approximately 1 lb. Compound injector burners using propane or butane at several pounds have also been employed, primary air being inspirated at the mixer and secondary air supplied by suction fans on the heaters. High-pressure inspirator burners have likewise been used with success. On many small drying, baking, and burn-off ovens these gases are used at line pressure through compound injectors and pipe or ribbon burners. Pipe burners are either ordinary drilled pipe or pipe fitted

with various kinds of tips such as ribbon, lava, steel, blast, multiple tube, &c. Improved atmospheric appliances are now available for use with undiluted propane or butane at low pressures as a result of co-operative research work with various manufacturers of such equipment. These improved appliances were not available in the early stages of development of these gases as there was little demand for them.

Located along many high-pressure natural-gas transmission lines are industrial plants using large amounts of natural gas for manufacturing glass, cement, brick, lime, and for smelting lead and zinc. These types of gas loads are termed 'main-line industrial', and are sold direct by the pipeline company at low rates with the provision that the service may be shut off on short notice, when and if the supply from the transmission line is required to handle domestic demand. Stand-by fuels are necessary in all such plants in order to maintain production on continuous processes during periods when gas is not available. Oil has been the principal stand-by fuel, but propane and butane offer decided advantages because of the similarity in combustion characteristics to natural gas, and because the same burners can be used, thus eliminating duplicate pipe-distribution systems and burners within the plant. These products as stand-by fuels provide the best possible assurance of continuous production.

An important recent development in the field of space heating is the use of propane or butane through unit heaters. This method of space heating is being used in a large number of industrial plants and in numerous other applications, such as heating of fruit houses, and has shown many economies over steam heat. Automatic temperature regulation, of course, is used. The initial investment in liquefied gas plant and unit heaters is usually much less than for an equivalent steam system. The efficiency of heat transfer is much greater, since the heat of fuel can be utilized directly instead of indirectly. For supplementing an over-taxed steam-heating system or for heating outlying buildings, these gaseous fuels have great possibilities.

Can-makers are using butane at a number of plants for soldering, sweating, lithographing, and other heating work. Such plants use a total pre-mix system on all soldering and sweating work. Uniform flame-length and high flame temperatures are important advantages of propane and butane for this specialized work. In heating lithograph ovens, the absence of sulphur compounds and other deleterious substances in the products of combustion minimize the number of rejections in the finished ware.

Results from the use of propane or butane as a carburizing medium in both rotary and continuous furnaces prove these fuels to be excellent for the purpose. Among the important advantages of these fuels over solid carburizers may be listed the following:

- 1 Lower labour cost
- 2 Lower fuel cost
- 3 Lower cost of carburizing medium
- 4 Uniformity of results
- 5 Flexibility

For glass-melting and annealing operations these fuels provide the clean, soft, long, luminous flame necessary for rapid and uniform melting. They may be used with or without preheated air, depending upon the type of container heated. The absence of sulphur compounds in the combustion products eliminates discoloration of finished ware in open-fired annealing furnaces. Bending and cutting-off operations are readily performed, due to the constancy of conditions which it is possible to maintain.

Many other industrial applications for these gases could be mentioned. With a better knowledge of the behaviour of these gases they will doubtless be extended to other fields of use in industry.

Gas Enrichment or Cold Carburetion.

Liquefied petroleum gases offer distinct possibilities in the field of blue-gas enrichment and for recarburetion to offset heating-value losses occurring in transmission systems. At the present time gas oil is almost universally used in the first of these applications. However, any future increases in the amount of motor fuel produced, assuming no great increase in the production of crude oil, will necessitate further cracking which will result in a decrease in the quantity of gas oil available. The quality of the gas oil available will also tend to be lowered. It would thus appear that the manufactured gas industry will eventually either have to lower the legal B Th U standards or obtain some other material for enrichment purposes. Since butane has been successfully used in place of gas oil in this application and also for purposes of recarburetion to offset the effect of condensation in mains, its use in such applications can be expected to increase.

Base Material for Manufacturing Gas.

The problem of meeting peak-load demands is one of serious importance to the gas industry. The low cost of liquefied petroleum gas storage, handling, and utilization equipment results in a low investment cost, with attendant low fixed charges and maintenance. In addition, the flexibility of the fuel and range of control are added characteristics that make these products valuable means of meeting peak loads with both manufactured and natural gas. Some of the many methods whereby increased capacity to meet peak loads can be obtained will be briefly outlined.

In the case of manufactured gas where the peak load is small and of short duration, propane added in undiluted form has proved to be an easy solution. When the volume of gas required is larger, it is undoubtedly more economical to use propane-air gas or butane-air gas, since the allowable volume increase is greater. A butane-air installation in California installed for this purpose increases the daily capacity of the oil-gas generating equipment about 35%. The total cost of the increased capacity is approximately 25% of the estimated cost of oil-gas equipment of similar capacity.

In the case of natural gas, it is possible by the addition of undiluted butane vapour to increase the volume approximately 11% and still be within the 20% allowable specific gravity increase. Due to the fact that this mixed gas would have a calorific value of approximately 1,300 B Th U per cubic foot, the total thermal increase would in reality be over 30%. This method is applicable when the peak load is a small one. However, when the peak volume is of any magnitude, it is more feasible to employ a liquefied gas-air mixture of 1,100 B Th U per cubic foot. Such a gas requires 10.72 U.S. gallons of butane per 1,000 cu ft and when used permits an overall volume increase of 30%. In the event of a percentage greater than 30% being required, it would be necessary to increase the thermal value of the butane-air mixture. Calculations show that a mixture of butane and air of higher calorific value would be interchangeable with natural gas in all proportions as far as appliance adjustments are concerned, thus providing a means of supplying gas service in an emergency. Various

tried and proved equipment for mixing, proportioning, and controlling these gases are available to the industry at a moderate cost. Numerous commercial installations of the nature of those outlined are being successfully operated, and wider use of such processes may be expected.

The cracking or reforming of butane or propane offers an additional means of meeting peak loads. Inasmuch as the calorific value, specific gravity, and chemical composition of the gas obtained in this manner can be varied over a wide range, it possesses a high degree of flexibility. Processes of this general type can be divided into three classes:

- 1 Straight cracking
- 2 Reforming through an incandescent bed of coke
- 3 Continuous catalytic processes

Each of the above types of processes offers distinct possibilities, and their application to various problems of gas manufacturing is a mere matter of economics.

Uninterrupted service is one of the prime requisites of good gas service. The probability of a break in transmission lines is admittedly remote, but ever present. The supply of gas required in such a case is in reality a special peak-load problem. Where peak-load equipment is installed, the cost of providing additional capacity to care for such an emergency is not excessive if advantage is taken of the availability of butane.

The cost of additional finished gas storage will vary, depending upon whether low- or high-pressure storage is used, as well as the size of the holders. The cost will range from \$60 to \$120 per 1,000 cu ft of capacity. Butane and propane, on account of their high thermal value and the fact that they can be stored in a liquid state, occupy but 1/136th (in the case of butane) of the volume that the thermal equivalent of natural gas of 1,100 B Th U at 75 lb gauge pressure would occupy. Consequently, the cost of storage for the butane equivalent of 1,000 cu ft of natural gas is approximately \$0.90 as compared to the figures previously given. It is, therefore, quite apparent that for reserve stand-by use, butane and propane offer distinct economies.

Special Uses.

Some special uses of propane found to be highly satisfactory are in connexion with oxy-propane cutting, either by hand or with machine torches. Several leading manufacturers of automobile bodies are using propane or butane and compressed air through hand torches for brazing, soldering, and local or spot annealing with much success. In these cases the new gas has replaced manufactured gas and some acetylene. The inflammable range for propane (2.4-9.6%) is much less than for manufactured gas. This means that close attention on the part of the torch operator is necessary if the proper and most efficient air-gas ratio is to be maintained when using manufactured gas. With propane the flame is necessarily efficient when it is satisfactory. With manufactured gas the flame may appear quite satisfactory over a large portion of the inflammable range, but since it is only efficient within narrow limits, the operator may inadvertently waste considerable gas. Plant engineers who have used propane or butane and manufactured gas estimate that the B Th U requirements are reduced by 5-15% when liquefied gases are used. Special torches designed for use with these gases are now generally available and have proved to be very satisfactory.

Internal-combustion engines of the large stationary type are also using propane and butane as fuel with excellent

results. The power developed in such cases is used for generating electric current, pumping liquids, or operating air and gas compressors. This application has proved itself to be an excellent supplementary one in plants using propane and butane for heating purposes, as no additional investment is necessary in the way of storage and vaporizing equipment. The combustion characteristics of these gases are ideal for smooth and efficient engine operation. Many small manufacturing plants have a high electric rate, and the use of propane- or butane-fueled engines as a means of generating electric current in such cases will frequently result in substantial savings.

Similarly, a number of large motor-car and industrial engine manufacturers are using propane and butane for their block-testing or 'wearing-in' operations. Practice in this respect differs widely regarding 'wearing-in' speeds, time, and method of mixing or carburetting. Gasoline and manufactured gas have been replaced at these plants by propane or butane. The advantages claimed for the latter gases in this work are:

- 1 Low fuel cost
- 2 Clean motors—elimination of carbon deposits on pistons and valves, absence of scale on valves
- 3 Improved idling characteristics
- 4 Cooler running motors
- 5 A more thorough or rugged test
- 6 Quicker starting of motors
- 7 Smoother running of engines—less 'loping'

The use of these fuels to replace gasoline on commercial truck and bus lines and also on new high-speed streamlined trains is becoming an important outlet. In such cases the engines must be of somewhat higher compression ratio if the greatest benefits are to be realized. It seems apparent that the use of liquefied petroleum gases as automotive fuels in the near future will be confined to those sections of the country where propane and butane are available in small quantities at prices lower than gasoline, and in other sections to those operators whose consumption is large enough to justify purchase in tank-car quantities, and in those vehicles which are operated on regular runs between points at which fuel storage is available. However, the advantages and simplicity of using liquefied petroleum gases, especially propane, for the combined use of refrigeration, air-conditioning, and fuel purposes in general will afford wider usage as soon as prospective users are more fully convinced of the merits and possibilities of these gases.

The applications of these products as special solvents, or as extraction mediums, although of little commercial importance at this time, are interesting. Limited quantities are being used for the purpose of extracting natural oils from seeds, fish, &c., where the commoner extraction agents would impart undesirable characteristics to the extracted product or to the residues. Limited quantities are also being used in new processes for the dewaxing of lubricating-oil stocks where the liquefied gases replace the more commonly used naphthas. In such cases the ordinary refrigerants are likewise dispensed with, since advantage is taken of the refrigerant properties of the new products.

Undoubtedly a market also exists for special highly purified propane, *iso*-butane, normal butane, &c., in the field of organic chemicals. The fact that such products can be made available in large volumes, of exceptionally high purity, and at moderate cost should prove to be a powerful stimulus in this field. Increasing interest is being manifested in these new chemical raw materials.

THE UTILIZATION OF LIQUEFIED PETROLEUM GASES

1541

Future Possibilities

Although the volume of liquefied gas sales has grown by leaps and bounds since this product first began to attract widespread attention in 1927, the field has been barely touched. The field for expansion in the utilization of this product, whether for gas-making purposes, for industrial fuel, or for bottled gas, is a large one. One authority estimates that at the present time in the United States the various fuels for domestic purposes are divided as follows

15,500,000 families using gas	
7,700,000	" " wood and coal
6,500,000	" " oil and kerosene
1,000,000	" " electricity
250,000	" " bottled gas

According to these figures, there are some 14,200,000 users of coal, wood, and oil that should be potential users of gas, of course, the locations of many of these are so remote that it will be impossible to furnish them with bottled-gas service, but to a large percentage this service will be available. In an attempt to survey the potential field for butane-gas and for undiluted propane distribution through pipelines, the latest available statistics were taken of towns of over 1,000 population with gas service. In the smaller communities undiluted propane would undoubtedly be the more feasible, while the larger towns would justify butane-gas plants. The data obtained show that in the United States there are 2,423 towns of between 1,000 and 2,500, and 667 towns of over 2,500 population without gas service. These figures are believed to be conservative ones. The volume of 140 million gallons of liquefied gas annually, estimated as required to supply these towns, is approximately twice the total present consumption and is approximately 7 times the volume that is at present being used for domestic gas service.

TABLE II

Liquefied Petroleum Gas Production and Consumption Estimates

Propane and butane	Thousands of barrels (42 gal) per year	Thousands of gallons per year
	Potential supply*	228,125
Estimated immediately available supply†	67,525	2,836,500
Consumption in 1937 for all purposes‡	2,540	106,652

* This figure does not include the extra butane it is expected will eventually find its way into motor fuel with the development of improved fuel systems.

† This figure likewise does not include the extra butane which eventually should find its way into motor fuel, although much of it is available and may remain available for some time. If such butane is included, the figure is increased by approximately 50%.

‡ Taken from U.S. Department of Interior, Bureau of Mines, Mineral Market Report No. M M S 543 of 19 May 1937.

It is recognized that in many of the towns surveyed it will be more economical to furnish manufactured or natural gas than to utilize these liquefied gases. However, in any event, there will be a large number where the cost of transmission lines will prove excessive, and we can look forward to an increasing number of liquefied gas plants to take care of such instances.

Of those potential customers who are too widely scattered to be economically reached by present methods of distribution, there are many who can be considered as potential bottled-gas users. What the possible saturation point in such cases will be is hard to estimate, due to the newness of the industry. However, if we assume that 1 family in 10 will eventually have gas service of this kind, it represents a potential field of at least 1,300,000 users. Assuming the average consumption per customer remains

TABLE III

Marketed Production of Liquefied Petroleum Gas in the United States

Year	Total sales			Distribution—gallons per year					
	U.S. gal per day	10,000 U.S. gal. tanks cars per day	Per cent increase over previous year	Bottled gas	Per cent increase over previous year	Industrial and miscellaneous	Per cent increase over previous year	Gas manufacturing	Per cent increase over previous year
1922	222,641	0 06							
1923	276,863	0 08	24 4						
1924	376,488	0 10	36 0						
1925	403,674	0 11	7 2						
1926	465,085	0 13	15 2						
1927	1,091,005	0 30	134 6						
1928	4,522,899	1 24	314 6	2,600,000		400,000		1,500,000	
1929	9,930,964	2 72	119 6	5,900,000	126 9	1,500,000	275 0	2,500,000	66 7
1930	18,017,347	4 94	81 4	11,800,000	100 0	2,200,000	46 7	4,000,000	60 0
1931	28,769,576	7 88	59 7	15,294,648	29 6	7,171,686	226 0	6,303,242	57 6
1932	34,114,767	9 35	18 6	16,244,103	6 2	8,167,194	13 9	9,703,470	53 9
1933	38,931,008	10 67	14 1	16,625,588	2 4	13,987,095	71 3	8,316,325	-14 3
1934	56,427,000	15 46	44 9	17,681,000	6 4	32,448,000	132 0	6,298,000	-24 3
1935	76,855,000	21 06	36 2	21,380,000	20 9	47,894,000	47 6	7,581,000	+20 4
1936	106,652,000	29 22	38 8	30,014,000	40 4	67,267,000	40 4	9,371,000	23 6

In the above table, 'Total Sales' were obtained from U.S. Bureau of Mines Reports. 'Distribution' for the years 1931 to 1936 was obtained from the same source. All other volumes are estimated by the writer. The total sales volume includes all liquefied petroleum gases (propane, butane, and propane-butane mixtures) when sold as such. It includes the sale of pentane when sold for any purpose other than motor fuel blending. It does not include butane when blended with heavier petroleum fractions for motor fuel purposes. Inter-company sales transactions, such as purchases of liquefied petroleum gases by one company and then resold as liquefied petroleum gases, have been eliminated in order to avoid duplication of sales figures. The data do not reflect sales of liquefied petroleum gases used directly by the producer at the point of production, for fuel, polymerization, solvent, de-waxing, &c. Neither do the figures include sales of gaseous mixtures of hydrocarbons delivered by pipeline to the few large chemical plants which are adjacent to the points of production of these raw materials, such sales are included if liquefied petroleum gases are in liquid form when sold.

as at present, this means an additional outlet for 120 million gallons per year.

The future possibilities of liquefied petroleum gas products as stand-by fuels, as peak-load fuels, as a substitute for gas-oil enrichment, as a direct industrial fuel for special heating applications, and as a fuel for internal-combustion engines are much more difficult to predict. In each of these instances the product is more directly competitive with other fuels which it must displace on the strength of possible lower investment requirements, fuel costs, &c., or on the strength of such intangible advantages as flexibility and final results obtained. Whereas its use in some of these cases may be partially upset whenever natural gas becomes more generally available, the use in other applications, particularly as peak-load or stand-by fuels and as a substitute for gas oil, will continue to increase. Any accurate prediction as to the ultimate volume going to their fields of use would quite obviously be an impossibility.

With the above ultimate possibilities estimated in so far as it is possible to do so, it is interesting to compare briefly

the figures on the available supplies, the estimated ultimate consumption, and the present consumption. Since conservation of natural resources is always of interest, these figures are of particular significance since the product is derived from an otherwise wasted raw material. The figures in Table II, based on 1936 observations, indicate the present status of supply and consumption for the United States on a yearly basis.

A break-down of the consumption figures for the period up to and including 1936 should also prove to be of considerable interest. The figures in Table III were taken from the U S Bureau of Mines Reports.

From the above analysis it is quite apparent that while considerable progress has been made in developing outlets for these new products, the field has been barely touched. Since the potential supplies are far in excess of the present demand, it is only to be expected that economic pressure will continue to play its part in securing outlets for a product which is so directly competitive in fuel markets.

SELECTED BIBLIOGRAPHY

GENERAL

- OBERPELL, G G *Oil and Gas J* 21 May 1931
 — *Gas Age-Record*, 8 Feb 1936
The Handbook of Butane-Propane Gases (1935)

UTILIZATION

Bottled-gas Use

- SETRUM, O M, and WRIGHT, L H. *Amer Gas J* Oct 1930
 THOMAS, H E *Western Gas*, March 1936

Central Plants for Small Communities

- BRENNAN, G L, and WRIGHT, L H. *Gas Age-Record*, 10 Jan 1931

- SETRUM, O M. *Ind Eng Chem* 23, 1190 (1931)
 THOMAS, R W, and SETRUM, O M. *Proc Southern Gas Association Convention*, 4 May 1932

Industrial Use

- BENZ, G R. *Oil and Gas J* 31 March 1932
 MCBRIDE, R S. *Chem Met Eng* 37, no 1 (1930)

Base for Gas Manufacture

- ODELL, W W. *Bureau of Mines Report of Investigations*, no 2,973 (Dec 1929)
 Report of Water Gas Committee. *Proc Amer Gas Association Convention* (1929)

SECTION 25
DISTILLATION

**Separation of Petroleum Hydrocarbons by Dis-
tillation**

**G GRANGER BROWN and
M SOUDERS, JR**

**Distillation in the Refining of Petroleum
Laboratory and Small-Scale Distillation**

W. A PETERS

**The Manufacture of White Spirits, Special
Naphthas, and Petroleum Solvents, by Dis-
tillation**

M R FENSKE

L CLEMENT

SEPARATION OF PETROLEUM HYDROCARBONS BY DISTILLATION

By GEORGE GRANGER BROWN, A.I.C.E., *Professor of Chemical Engineering*, and MOTT SOUDERS, Jr., Ph.D., A.I.C.E., *Consulting Engineer*
University of Michigan, Ann Arbor, Michigan

PART A. THEORY

In the petroleum industry 'distillation' is a generic term which includes simple batch operations, flash vaporization, gas absorption, and steam stripping as well as stabilization, rectification, or fractionation. In general, distillation refers to those processes which attempt the separation of the more volatile from the less volatile materials of a mixture by means of the distribution of a component between vapour and liquid phases in direct contact.

Calculations dealing with distillation processes usually involve, among other factors, the computation of temperature, pressure, and heat requirements, and the quantities and qualities of the separated products. Such computations are based upon the fundamentals of vapour-liquid equilibrium and heat and material balances.

Vapour-liquid Equilibria

Vaporization may be defined as the change from the more dense phase (usually liquid) to the less dense phase (vapour) in a system composed of two phases. When vaporization results from the application of heat to a mixture of hydrocarbons under a constant pressure, part of the energy is absorbed by the expansion involved in the change of phase, and part is expended in raising the temperature of the mixture. The rise in temperature increases the tendency of all components of the mixture to leave the liquid and enter the vapour phase. Therefore, the vapour rising from a liquid contains some of each of the components present in the liquid. The escaping tendency for the more volatile components, however, is greater than for the less volatile components. Thus the vapour is richer in more volatile components and poorer in less volatile components than the liquid remaining, and the residual liquid is richer in less volatile and poorer in more volatile components than the original liquid before the heating and vaporization occurred. Moreover, the vapour necessarily is richer in more volatile components than the original liquid unless the mixture is heated to a temperature at which it is completely vaporized, in which case the vapour will have the same composition as the original liquid.

Condensation is essentially the inversion of vaporization. It follows, therefore, that the condensate is richer in less volatile and poorer in more volatile components than the original vapour (unless the vapour is all condensed) and the remaining vapour is richer in more volatile components than the condensate.

The change of state from liquid to vapour or from vapour to liquid is not unidirectional. Although the escaping tendency of the liquid molecules may be greater than the escaping tendency of the vapour molecules, some of the gaseous molecules will re-enter the liquid phase. This may be explained by the non-uniform distribution of energy among the molecules, some of which have greater velocity than others as the result of collisions or other effects, so

that the 'slow' vapour molecules 'fall' back into the liquid and some of the more active liquid molecules break from the liquid surface and re-enter the vapour phase.

When the rate at which molecules leave the liquid is equal to the rate at which vapour molecules re-enter the liquid, the system is said to be in equilibrium, and neither vaporization nor condensation appears to be taking place. In reality, however, both are occurring simultaneously but at equal rates, so that the system is dynamically balanced.

Ideal Equilibrium Constant.

The ideal solution is defined as a solution in which the rate of escape of each component is proportional to the mole fraction of that component. It implies among other things that the volumes and heat contents of the individual components are additive. Thus the rate at which molecules of any particular component of an ideal solution leave one phase to enter another is equal to the product of the escaping tendency of the pure component and the mole fraction in that phase. At equilibrium the rate of escape from the liquid phase is equal to the rate of escape from the vapour phase, so that the ideal vapour-liquid equilibrium constant may be defined as the ratio of the mole fractions of a component in the vapour and liquid phases or as the ratio of the escaping tendencies of the pure component from the liquid and vapour phases. That is

$$K = \frac{y}{x} = \frac{\text{escaping tendency from liquid}}{\text{escaping tendency from vapour}} \quad (1)$$

(For definitions of these and subsequent symbols see Table of Nomenclature.)

In treating mixtures of hydrocarbons it has been customary in the past to assume the validity of Raoult's and Dalton's laws, in which the escaping tendency from the liquid phase is measured by the vapour pressure of the pure component, and from the vapour phase by the total pressure, i.e.

$$K = \frac{p}{P} = \frac{y}{x} \quad (2)$$

The evaluation of K from Raoult's and Dalton's laws is valid for ideal solutions only when the vapour phase is an ideal gas or when the total pressure is of the same order of magnitude as the vapour pressure of the component in the pure state. Thus the application of Raoult's and Dalton's laws to problems in petroleum distillation is justifiable only at low pressures (less than two or three atmospheres) and with mixtures of relatively narrow boiling-range.

A measure of escaping tendency more fundamentally correct than vapour pressure or total pressure is available in the 'fugacity' proposed by G. N. Lewis [15, 16, 1901] and computed from pressure-volume-temperature data for petroleum hydrocarbons by Selheimer, Souders, Smith, and Brown [29, 1932] and Lewis and Luke [17, 1932]. When fugacities are used as measures of the escaping

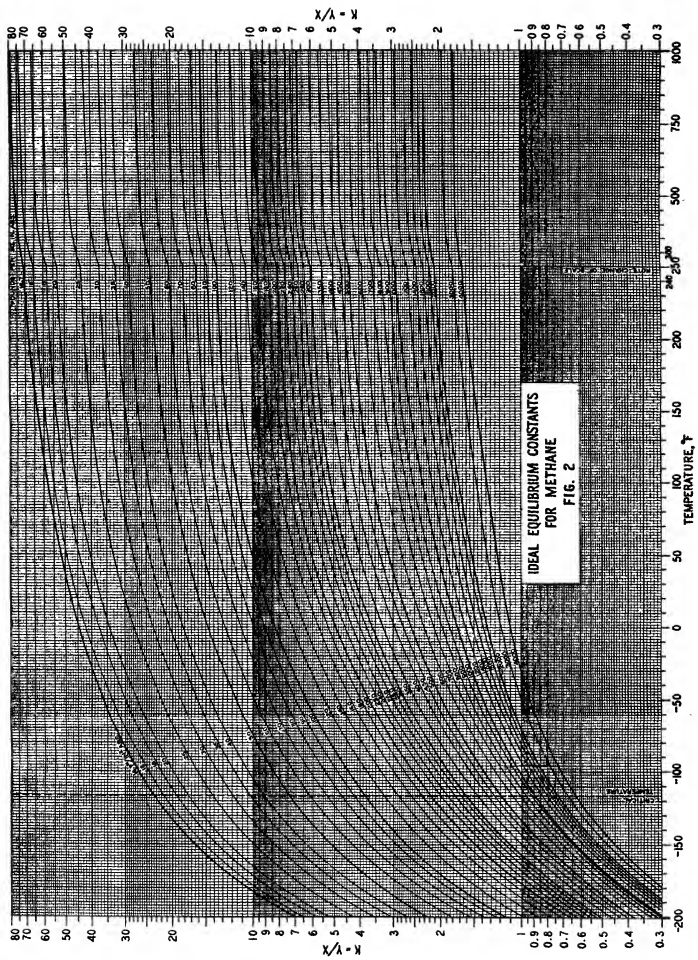

tendencies, equation 1 for vapour-liquid equilibria in ideal solutions becomes

$$K = \frac{p}{x} = \frac{f_L}{f_V}, \quad (3)$$

where f_L = fugacity of a component as a pure liquid at temperature and pressure of equilibrium,
 f_V = fugacity of same component as a pure vapour at temperature and pressure of equilibrium

The ideal equilibrium constants, K , as defined by equation 3, avoid the errors of Raoult's and Dalton's laws and are more easily applied and more readily extrapolated than are the individual fugacities

charts for methane, ethane, propane, iso- and *n*-butanes, iso- and *n*-pentanes, *n*-hexane, and *n*-heptane are given in Figs 2 to 10 inclusive

To determine K under conditions where Raoult's law is not valid for hydrocarbons or petroleum fractions of greater molecular weight, Fig 11 representing relative values of K , may be used (Katz and Brown [13, 1933]). The values for the higher molecular weights are uncertain, but the chart is considered reliable for molecular weights up to about 200, and is the best means available for extrapolating these data to include compounds of higher molecular weight

In order to find the value of K for any component at

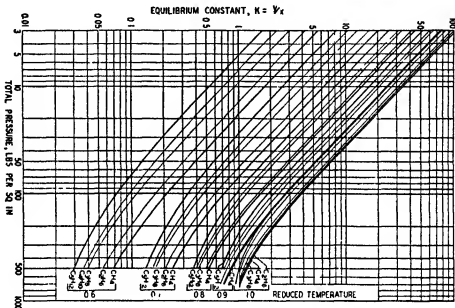

FIG. 1. Equilibrium constant as function of pressure

Logarithms of these equilibrium constants have been plotted in Fig 1 as a function of the total pressure on curves of constant reduced temperature (ratio of the absolute temperature to the absolute critical temperature) for paraffin hydrocarbons from methane to pentane inclusive (Souders, Selheimer, and Brown [33, 1932]). The lines are straight and parallel at the lower pressures and for the low-molecular-weight hydrocarbons. At higher pressures and for higher molecular weights the lines become curved concavely upwards. The form of the chart is well adapted for extrapolation which is necessary for the petroleum fractions of higher molecular weight. This extrapolation is accomplished by determining the vapour pressure of the pure component at the desired temperature, thereby locating the total pressure at which the value of K is unity. The desired value of K at any other total pressure at the chosen temperature may then be estimated by extending a curve through the vapour-pressure point (unit K) parallel to the pentane curve of the same reduced temperature and reading the intersection of the extended curve with the ordinate of the desired total pressure (Brown and Souders [4, 1932]).

Although Fig 1 is well adapted to extrapolation, it is not convenient for use in equilibrium calculations. Charts in which K (on a logarithmic scale) is plotted against temperature (in $^{\circ}$ F) on curves of constant pressure (in lb per sq in abs) are more convenient to use. Such

any temperature and pressure, it is necessary to know the molecular weight, the critical temperature, and the vapour-pressure characteristics of the compound. By definition K is unity when the vapour pressure p equals the total pressure. The value of K for each and every component in a mixture is also equal to unity at the critical point of the mixture. This fact must be considered and the values of K modified accordingly near the critical point of a mixture.

The value of K for any component may be found as follows: Determine the vapour pressure of the component at the desired temperature of the equilibrium from a boiling-point of the component by the vapour-pressure chart. Using Fig 11, choose the curve corresponding to the molecular weight of the component and the reduced temperature at which the value of K is desired. The intersection of this curve with the pressure abscissa equal to the vapour pressure of the component at this temperature determines the ordinate which has unit value ($K = 1$). The scale of K along the ordinate is entirely relative, and must be given absolute value for each determination in this manner. Set a pair of dividers to the difference between the ordinate of this point of intersection and the ordinate indicated as unity on the K scale shown in Fig 11. Lay off this same length, or difference in ordinates, from the curve at any desired total pressure to read the value of K for that total pressure directly on the K scale of the figure.

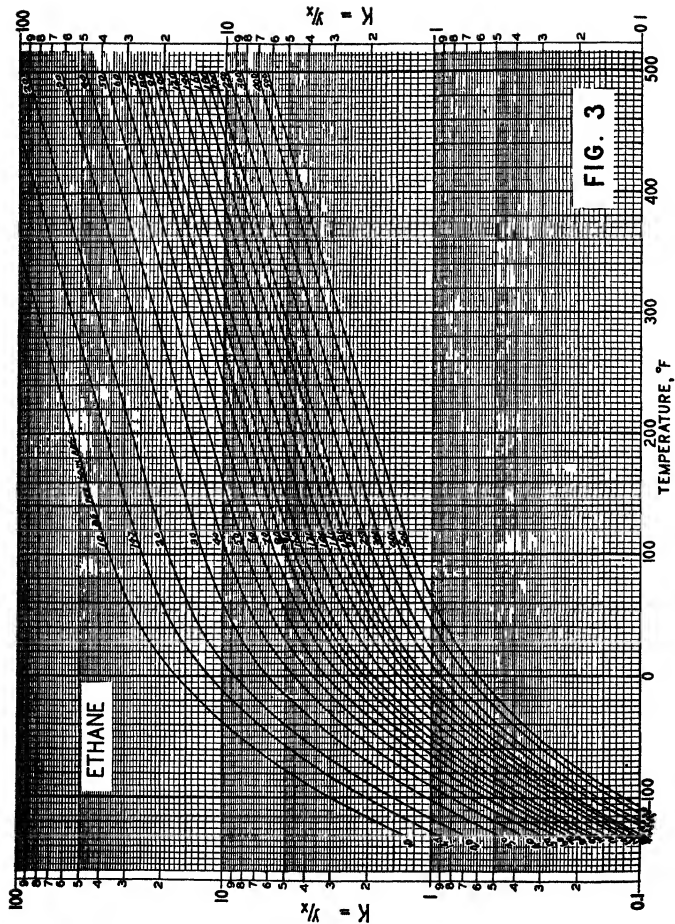

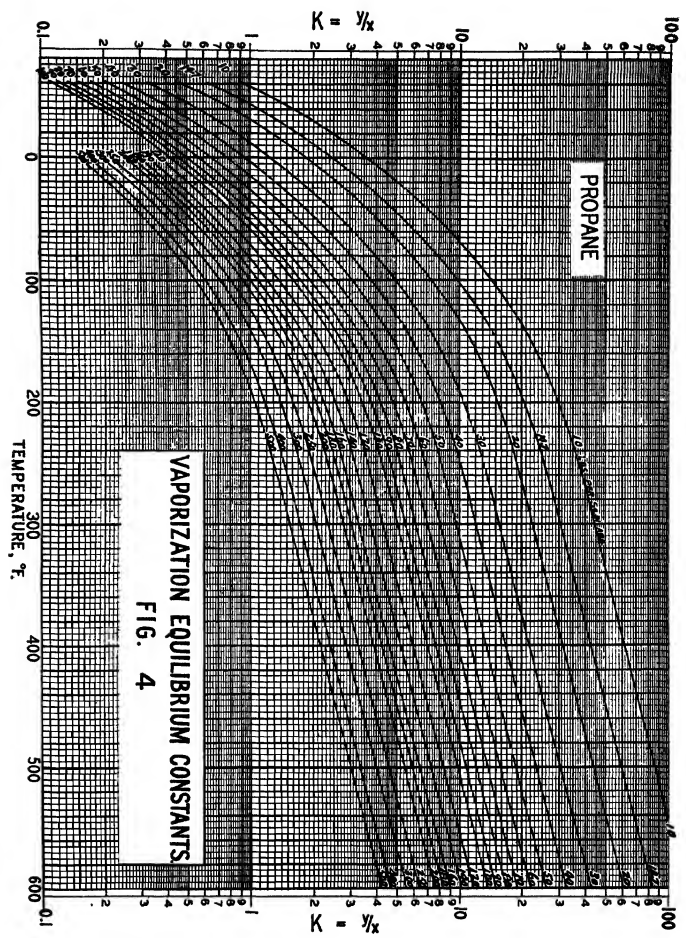

Deviation from Ideal Solutions.

The values of the equilibrium constants presented in Figs. 1 to 11 are for ideal solutions. Since these values of K are based on the fugacities of the pure component (mole fraction of unity), the ideal values of K should be most reliable in actual solutions when applied to components present in large concentrations.

Brown and Souder [4, 1932] report an apparent positive deviation of almost 100% for methane present in low concentrations in absorption oil. Recently Matheson and Cummings [20, 1933] have determined the deviation in Raoult's law at low pressure as a function of concentration of the paraffin hydrocarbon in an absorption oil. These deviations are largely deviations from ideal solutions, and may be used as such for correcting the values of K . The corrections indicated in Fig. 12 represent the best available data on the deviation from ideal solutions and may be used to correct values of K for concentration, particularly of the more volatile components in the liquid phase. This is done by multiplying the value of K by the correction factor as indicated in Fig. 12 according to the molecular

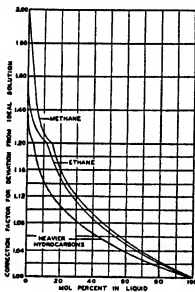

FIG. 12. Multiply value of equilibrium constant, K , by correction factor according to mole fraction in the liquid as indicated in this figure.

percentage of the component in the liquid. This correction is important when dealing with natural gasoline and gaseous components, particularly when dissolved in heavier solvents, but does not appear so necessary for the higher-molecular-weight components encountered in heavy oils. This may be due to greater accuracy of the plots and analytical methods when applied to gases and gasoline components.

The approximate accuracy of the values of K for the more volatile hydrocarbons has been checked by comparison with reflux and residue gas from natural gasoline rectifiers. Data from Raigorodsky and Rector [27, 1932] are compared in this way with the computed equilibrium conditions at 75° F and 268 lb per sq in abs.

These data given for normal paraffin hydrocarbons also include considerable quantities of unsaturated compounds. The agreement between the values for y/x computed by the ideal solution relationship as obtained from

Fig. 2-10 and the values obtained from actual analysis is generally satisfactory, and much better than between Raoult's law and actual analysis. The corrections for deviations from ideal-solutions as given in Fig. 12 modify the values as shown in the last column, which are very close to the experimental values.

TABLE I
Comparison of Calculated and Experimental Equilibrium Constants for Volatile Hydrocarbons

(At 75° F and 268 lb per sq in absolute pressure)

Component	By analysis			Calculated y/x		
	Mol fraction			By Raoult's law	By K from Figs 2-10	K cor by Fig 12
	In residual gas, y	In residual flux, x	y/x			
CH ₄	0.393	0.027	14.6	35	8.2	14.3
C ₂ H ₆	0.257	0.125	2.06	2.2	1.63	1.96
C ₃ H ₈	0.261	0.46	0.567	0.5	0.6	0.63
iso-C ₄ H ₁₀	0.088	0.374	0.235	0.186	0.27	0.238
C ₅ H ₁₂			0.127	0.20	0.214	
C ₆ H ₁₄	0.001	0.014	0.07	0.035	0.066	0.078

At the critical point of a mixture at which the vapour and liquid phases merge into a single phase, the equilibrium constant of each component of the mixture becomes unity. For this reason the ideal equilibrium constants of Figs. 2 to 11 must be modified for each particular mixture when equilibrium calculations are to be made at temperatures and pressures near the critical point of that mixture. In this connexion it should be noted that the critical pressure of a mixture of hydrocarbons frequently is greater than the critical pressure of the most volatile component of the mixture.

Vaporization of Hydrocarbon Mixtures

From the fundamental equilibrium equation, equation 1, and material balances around a vaporizing or condensing process it is possible to develop a number of useful equilibrium equations.

Dew-points and Bubble-points.

The vapour pressure of a known liquid mixture of hydrocarbons at any temperature is readily calculated as the sum of the products of the mole fractions and the corresponding vapour pressures at the indicated temperature.

$$\text{Vapour pressure} = \sum (xp), \quad (4a)$$

Or by trial and error, when using the equilibrium constants K , until the correct value for P is found, when

$$\sum (xK) = 1 \quad (4)$$

The bubble-point, or temperature at which vapour will begin to form from a known liquid mixture at any pressure, may be calculated by a trial and error method in which the vapour pressures, or equilibrium constants, K , of the individual hydrocarbons are determined for an assumed temperature, and the vapour pressure of the mixture computed for the assumed temperature, the proper solution is readily obtained by graphical interpolation, using the vapour-pressure curve of the mixture so computed by equations (4) or (4a) to indicate the temperature at which the mixture has the desired vapour pressure.

The dew-point of a known vapour mixture, or tempera-

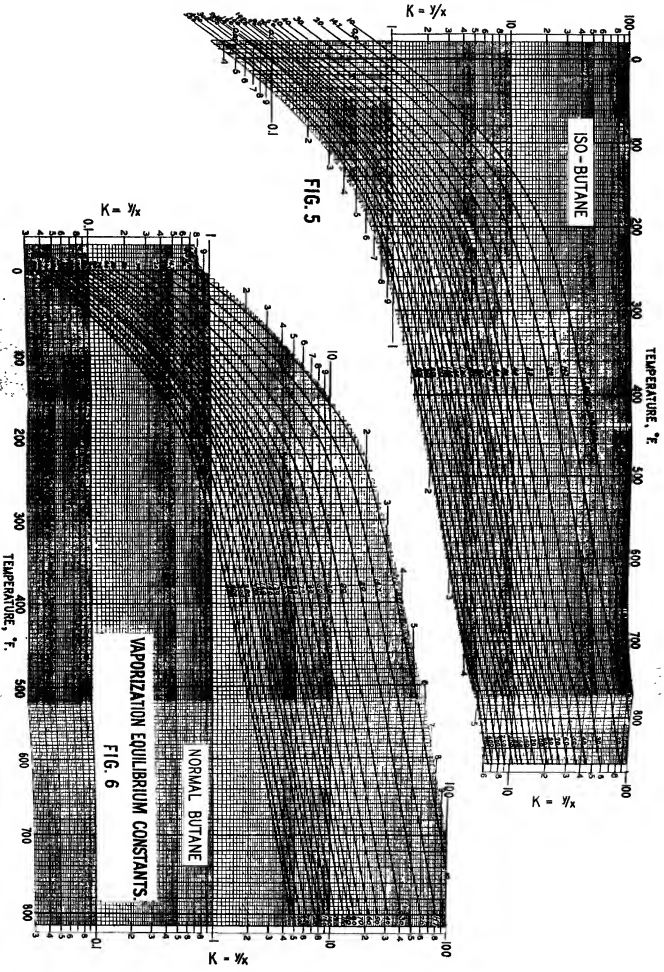

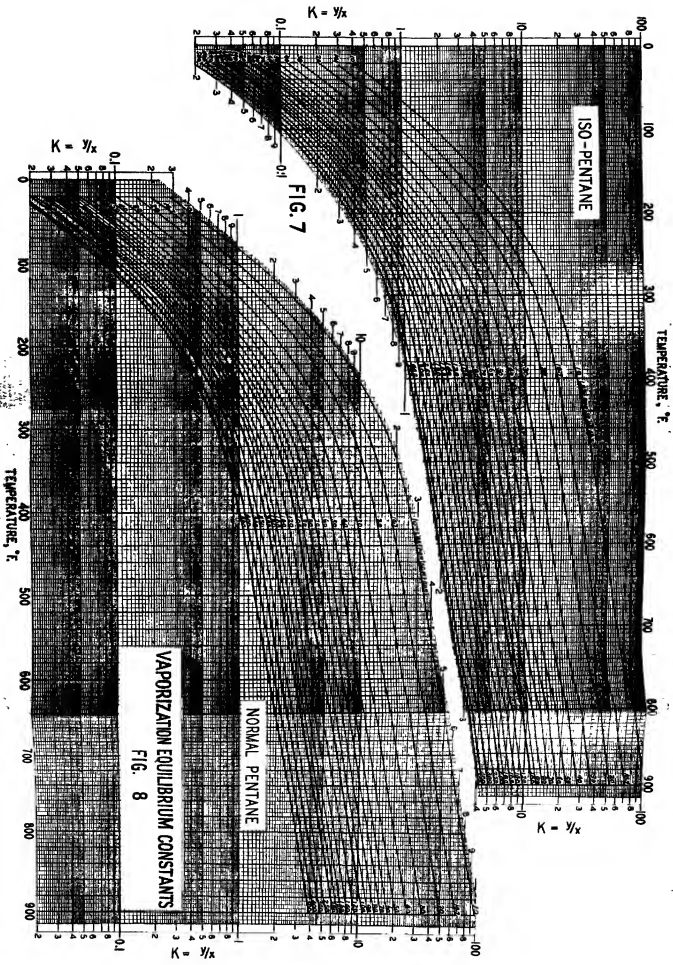

ISO-PENTANE

FIG. 7

NORMAL PENTANE

VAPORIZATION EQUILIBRIUM CONSTANTS
FIG. 8

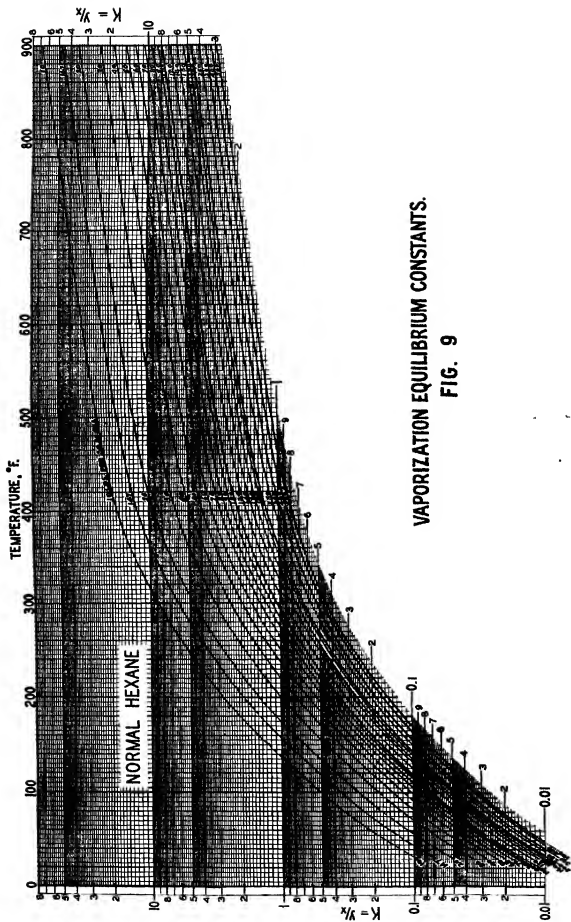

VAPORIZATION EQUILIBRIUM CONSTANTS.
 FIG. 9

NORMAL HEPTANE

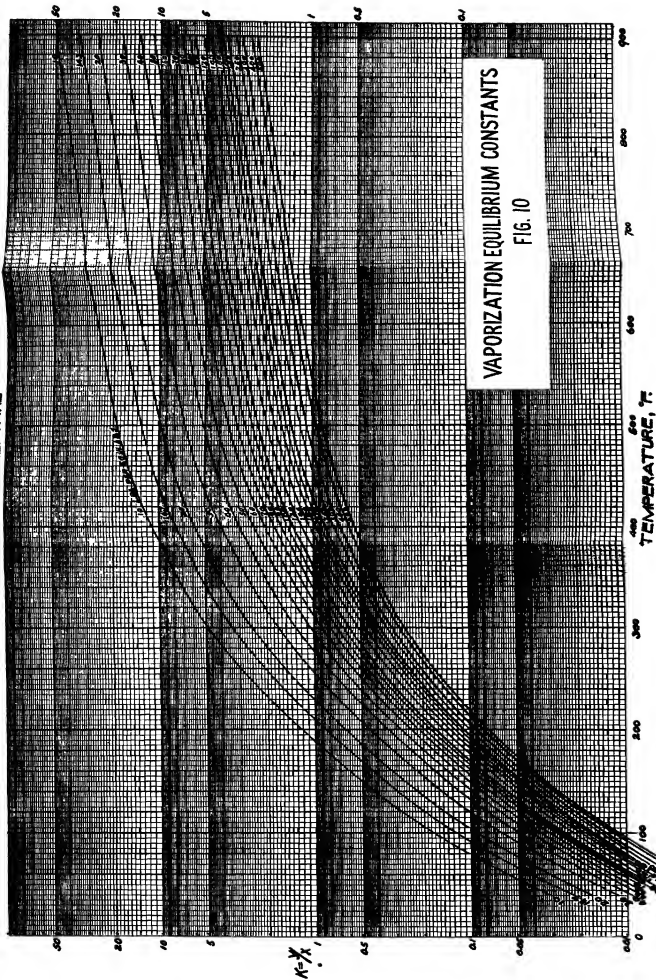

VAPORIZATION EQUILIBRIUM CONSTANTS
Fig. 10

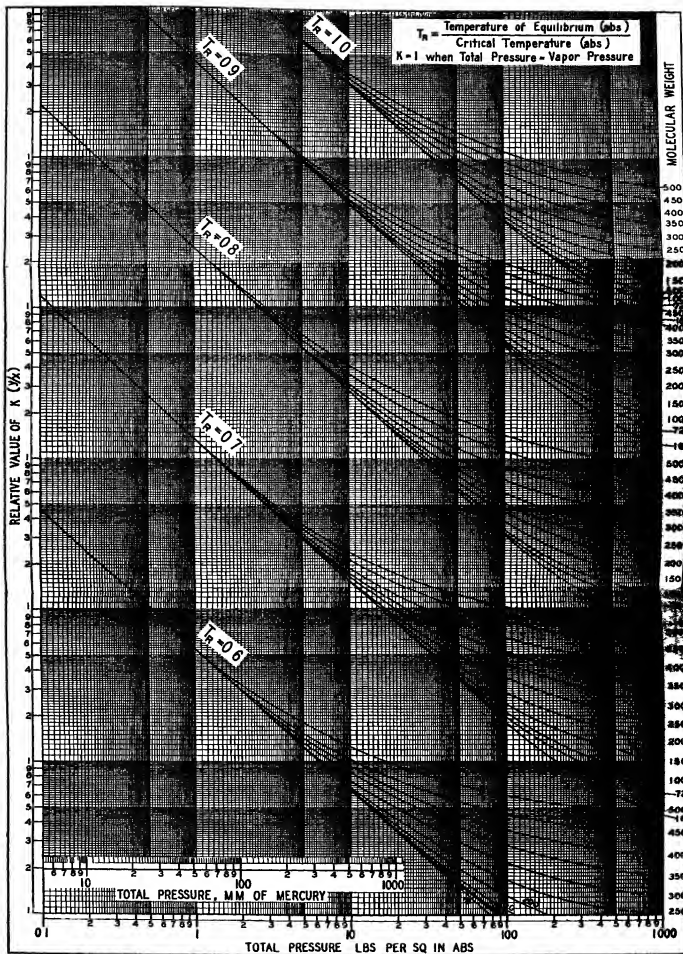

FIG 11

ture of initial condensation at any pressure, may be calculated by trial and error as the temperature at which

$$\sum \left(\frac{y_i}{p} \right) = \frac{1}{P}, \quad (5a)$$

or

$$\sum \left(\frac{y_i}{K} \right) = 1 \quad (5)$$

This method may be used to include mixtures of hydrocarbon vapour with air or other gases

Equations (5) and (5a) may also be used to determine the pressure, P , of initial condensation of a known vapour at any temperature. In this case equation (5a) may be solved directly, but trial and error methods must be used for equation (5)

Flash or Equilibrium Vaporization.

The quantity vaporized and the quality of the vapour and liquid formed under equilibrium conditions at a stated temperature and pressure from a mixture or feed of known composition may be calculated as follows

By a material balance,

$$F = V + L, \quad (6)$$

where

$$\begin{aligned} F &= \text{moles of feed to column,} \\ V &= \text{moles of vapour, and} \\ L &= \text{moles of liquid overflow} \end{aligned}$$

By a material balance for each hydrocarbon,

$$zF = yV + xL, \quad (7)$$

in which z = mole fraction of a component in the feed

Substituting y/K for x in equation (7) and solving for y gives

$$y = \frac{zF}{V + L/K} = \frac{F}{V} \left(\frac{Kz}{K + L/V} \right) \quad (8)$$

Similarly, substituting Kx for y and solving for x gives

$$x = \frac{F}{V} \left(\frac{z}{K + L/V} \right) \quad (9)$$

Since the sum of the mole fractions of all the hydrocarbons in the liquid equals unity, and the sum of the mole fractions of all the hydrocarbons in the vapour equals unity,

$$\sum y = 1 = \frac{F}{V} \sum \frac{Kz}{K + L/V} \quad (10)$$

$$\sum x = 1 = \frac{F}{V} \sum \frac{z}{K + L/V} \quad (11)$$

Solving for V/F from each equation gives

$$\frac{V}{F} = \sum \frac{Kz}{K + L/V} = \sum \frac{z}{K + L/V} \quad (12)$$

The values of K are for each hydrocarbon at the temperature and total pressure of the equilibrium

The quantity vaporized is found by trial and error, by assuming a value of V for any desired quantity of feed, F , and determining the values for either summation in equation (12). This is done by determining the value of the expression for each hydrocarbon and adding all of these values to determine the value of the summation. The correct solution has been obtained when the value of the summation is equal to the assumed value for V/F . Usually the results of two or three trials may be plotted against the assumed value for V/F and the solution obtained by interpolation

The quality of the vapour, and liquid, expressed in terms

of mole fraction, is readily obtained by use of equations (8) and (9) for each of the hydrocarbons

Complex Mixtures.

Complex mixtures may be considered as a mixture of close-cut fractions, each of which has the properties of a pure hydrocarbon, and treated in the manner described, or the same relationship may be used in the differential form and applied to complex mixtures in which the composition may be expressed as a true boiling-point curve as obtained from an efficient column distillation in the laboratory, in terms of components identified by their boiling-points

Since it is required that the composition of the mixture be expressed in terms of mole fraction, it is necessary to convert the true boiling-point curve from a weight to a molecular basis. This may be done by considering the whole sample as composed of a number of close-cut fractions, as obtained by dividing the true boiling-point curve of the entire sample into a number of arbitrary fractions. Each of these close cuts has a molecular weight which may be determined from its average boiling-point by means of a curve of molecular weight vs average boiling-point as determined experimentally on a number of cuts from the sample, or by means of the average boiling-point and the gravity as suggested by Watson and Nelson [38, 1933]. If the source of the material is known, the molecular weight may be determined as a generalized function of the average boiling-point. The weight of each close-cut fraction per unit weight of total sample is divided by the molecular weight of the fraction to determine the number of moles. The mole fraction in each of the close-cut fractions is then determined by dividing the number of moles in the fraction by the total number of moles in the unit weight of the whole sample. From these data and the boiling-range of each fraction a true boiling-point curve may be constructed, expressed in terms of mole fraction and used to indicate the molecular composition of the sample

The above equations derived for mixtures of individual hydrocarbons may be put into the differential form

$$\int dx = \frac{F}{V} \int \frac{1}{K + L/V} dz \quad (13)$$

$$\int dy = \frac{F}{V} \int \frac{K}{K + L/V} dz, \quad (14)$$

where dx , dy , dz = mole fraction of the differential component boiling between T and $(T+dT)$ as defined by the molecular true boiling-point curve as described above

In these equations the properties of the complex mixtures are assumed to be continuous—i.e. form a smooth curve throughout the entire range of composition, enabling one to use the data and properties of the pure hydrocarbons for any point on the true boiling-point curve. These equations may be integrated graphically between the limits of $z = 0$ and $z = 1$ by plotting the expression $1/(K + L/V)$ or $K/(K + L/V)$ as a function of z , using as many points as desired to obtain the required accuracy in the curve. This integral must equal V/F since the integral of dy and of dx must be equal to 1 when integrated between the corresponding limits. This graphical method may be applied in exactly the same manner as has been described for the method of summations in computing the quantity of vapour and liquid formed in an equilibrium vaporization

The quality of the liquid and vapours are also obtained in a similar manner. When the proper values of L and V

have been inserted in the equation, the integral curve multiplied by F/V gives x or y as a function of z . Since the boiling-point is known as a function of z from the true boiling-point curve of the feed, the true boiling-point curve of the liquid or vapour may be readily constructed by plotting boiling-point as a function of x or y .

From these equations the vapour pressure, dew-point, bubble-point, and equilibrium vaporization may be calculated almost as readily for complex mixtures as for mixtures of individual hydrocarbons.

For complex mixtures,

$$\int dy = \int K dx, \quad (15)$$

which may be used in exactly the same way as $\sum y = \sum Kx$ for determining vapour pressure, bubble-point, and dew-point, as has been described for mixtures of hydrocarbons.

A complete example of the use of these equations in calculating the vaporization of complex mixtures is presented by Katz and Brown [13, 1933].

Empirical Methods.

The amount of liquid and vapour formed in an equilibrium vaporization at atmospheric pressure is usually expressed as an equilibrium vaporization curve which shows the percentage of vapour formed in an equilibrium vaporization as a function of temperature. An empirical relationship between the equilibrium vaporization curve and the ASTM and the true boiling-point curves was found to exist by Proomov and Beiswenger [26, 1929]. The equilibrium vaporization curve was assumed to be a straight line and its slope was found to be related to the

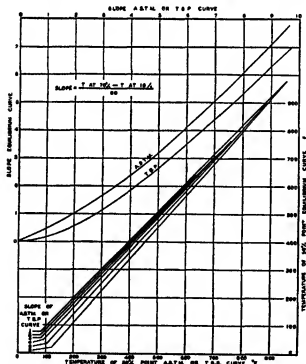

FIG 13 Empirical method for determining equilibrium vaporization curve

(T B P = true boiling-point)

slope of the ASTM or true boiling-point distillation curve between the 10% and 70% points. The point of intersection of the equilibrium vaporization curve with the

ASTM or true boiling-point curve was related to the 50% point on the distillation curve and the slope of the distillation curve.

For pressures greater than atmospheric it was suggested that the point of intersection be raised according to the vapour-pressure curve of a pure hydrocarbon.

A similar but somewhat more convenient type of plot suggested by Nelson and Souders [22, 1931] has been constructed on the basis of all available data. This plot (Fig 13) relates the slope of the equilibrium vaporization curve to the slope of the batch-distillation curve, and the 50% point of the equilibrium-vaporization curve to the 50% point of the batch-distillation curve with a correction for the slope of the latter.

The use of Fig 13 may be demonstrated by application to the California naphtha used for illustrative examples by Katz and Brown.

The slope of the true boiling-point curve between 10% and 70% points is 2° F per %, and the 50% point is 350° F from data in Table III.

From the slope (2° F per %) of the true boiling-point curve, the slope of the equilibrium-vaporization curve is found to be 0.52. The 50% point of the equilibrium-vaporization curve is 346° F as determined from the 50% point and the slope of the true boiling-point curve. To find the percentage vaporized in a vaporization at 350° F, locate the 50% point of the equilibrium-vaporization curve at 346° F and draw a line through this point with a slope of 0.52° F per %. The intersection of this vaporization line with 350° F at 58% indicates that 58% vapour would be formed compared with 60.2% as determined experimentally (Table II).

TABLE II

Comparative Results on Quantity of Vapour from Equilibrium Vaporization of a California Naphtha

	Feed vaporized at 350° F (177° C) and 760 mm	
	Mole %	Wt %
Experimental (3)	63.4	60.2
Raoult's law	65.7	62.6
Raoult's law modified by $k = 0.9$	50.5	47
Ideal solution K	65.5	62.4
Empirical method	61.0	58.0

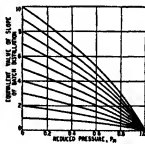

FIG 14 Correction of slope of equilibrium vaporization curve for different pressures

Use the equivalent slope of the batch distillation as indicated in this figure for determining the slope of equilibrium vaporization curve (if the pressure of vaporization is other than atmospheric) use with Figs 13, 15, 16.

$$\text{Slope} = T'' \text{ at } 70\% - T'' \text{ at } 10\%$$

60

Similar methods are applied in using the relationship between the equilibrium vaporization curve and the

ASTM distillation, using the proper curve for the relationships between the slopes.

For estimating the equilibrium vaporization curves at higher or lower pressures, the 50% point of the equilibrium-vaporization curve may be modified according to the vapour-pressure curve of a pure hydrocarbon, and the slope obtained by applying the correction indicated in Fig. 14 to the slope of the batch distillation. The curves shown in Fig. 14 were derived from limited data, but their use is justified until more accurate data are available.

Equilibrium Curves.

Equilibrium curves of the type suggested by Obryadchakoff [23, 1932] may be readily and accurately calculated from the composition of the vapour or of the liquid. These equilibrium curves are constructed by plotting along the ordinate the percentage of material boiling below any temperature (T') in the vapour and along the abscissa the percentage of material boiling below the same temperature (T'') in the liquid in equilibrium with the vapour. This method assumes that for equilibrium purposes any complex mixture may be considered as composed of two components, one representing all the material boiling below any chosen temperature and the other representing all the material boiling above this temperature in either liquid or vapour. Obryadchakoff has indicated that a single equilibrium curve may be used for any pair of such components for a given mixture. These curves are a most convenient means for expressing equilibrium compositions of vapour as a function of that of the liquid, since they simplify all complex mixtures to equivalent binary mixtures.

These curves may be constructed in an accurate and convenient manner by means of the equilibrium constants, using equation (15) for calculating mole fraction in vapour (y) as a function of mole fraction in liquid (x) boiling below the same temperature. Equation (16) may be used in the same manner when the composition of the vapour is known in terms of a boiling-point analysis. The integrals of the curves of K as a function of x or $1/K$ as a function of y give the equilibrium curve directly, as both integrals must equal unity.

If it is desired to find the weight per cent composition of a vapour from a weight per cent curve of the liquid, the following relationship holds:

$$\int_0^1 dy' = \frac{M_L}{M_V} \int_0^1 K dx' = 1, \quad (16)$$

in which dy' = weight per cent of the differential component in the vapour,

dx' = weight per cent of same component in the liquid,

M_L = average molecular weight of liquid,

M_V = average molecular weight of vapour.

This equation appears to require the molecular weights of the vapour and liquid for its solution, but the fact that M_L/M_V times the integral equals unity at equilibrium makes it possible to solve the equation without the knowledge of either molecular weight. The ratio of the molecular weights may be calculated from the integral evaluated between limits of zero to one and may be applied to the integrals for all the intermediate values of x' .

The corresponding equation for computing the composition of the liquid,

$$\int_0^1 dx' = \frac{M_V}{M_L} \int_0^1 \frac{dy}{K} = 1 \quad (17)$$

may be utilized in a similar manner.

In estimating the quality of vapour and liquid formed in an equilibrium vaporization, empirical equilibrium curves of the type suggested by Obryadchakoff may be used with satisfactory results in most cases, particularly relatively close-cut fractions.

A relationship has been found between the slope of this equilibrium curve and the slope of the batch-distillation curve of the feed material. The available data have been carefully analysed, and equilibrium curves based on true boiling-point distillation curves are indicated in Fig. 15.

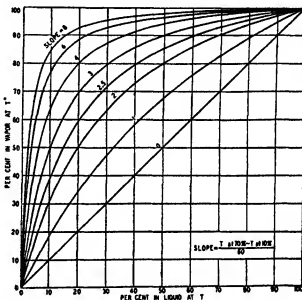

FIG. 15 Equilibrium curve for true boiling-point or column distillation data. Figures on curves indicate slope of distillation curve of feed.

$$\text{Slope} = \frac{T'' - T'}{60} \text{ at } 10\%$$

and similar curves based on ASTM distillation data are given in Fig. 16. The numbers on the curves indicate the slope, usually between 10% and 70%, on the batch-distillation curve of the feed for which the equilibrium curve may be used. These curves are based upon equilibrium conditions at atmospheric pressures, but may be used for other pressures by using a curve corresponding to a different slope for the batch distillation as indicated in Fig. 14.

From a knowledge of the quantity of vapour and liquid formed in an equilibrium vaporization as determined from Figs. 13 and 14, the quality of the vapour and liquid expressed as a distillation curve can be obtained from the composition of the feed by use of Fig. 15 or 16 in the following manner. The percentage of the vapour as indicated along ordinate y and the percentage of the liquid as indicated along abscissa x will distil at temperature t on the true boiling-point curve of the feed, corresponding to the percentage of the feed equal to $yV + xL$, where V and L represent percentage total vapour and percentage total liquid based on feed. This percentage of the feed is obtained by multiplying the percentage of the vapour as indicated on ordinate y by the percentage of feed vaporized,

and adding to this product the product of the corresponding abscissa x and the percentage of feed left as a liquid in the equilibrium vaporization. This sum is the percentage of the feed distilled at temperature t in the batch-distillation feed

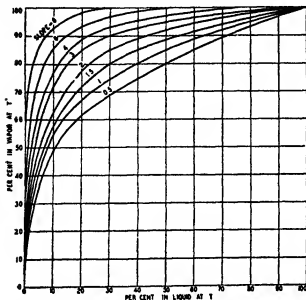

FIG 16 Equilibrium curve for A S T M distillation data. Figures on curves indicate slope of A S T M distillation curve of feed

$$\text{Slope} = T^{\circ} \text{ at } \frac{70\% - T^{\circ}}{60} \text{ at } 10\%$$

The quantity of vapour formed in the equilibrium vaporization of the same California naphtha was determined in the manner indicated as 58%. In order to introduce no extraneous error, the experimental value of 60% for this naphtha is used in this demonstration. Equilibrium curve 2 in Fig 15 is used because the slope of the batch-distillation curve is 27°F per %. Fifty per cent of the vapour is distilled at the same temperature as 20% of the liquid residue. Fifty per cent of the vapour is 30% of the feed because the total vapour is 60% of the feed. Twenty per cent of the liquid is 8% of the feed because the total liquid is 40% of the feed. Therefore the temperature of 50% of the vapour and 20% of the liquid is that of 30+8

TABLE III

Comparative Results on Quality of Vapour from Equilibrium Vaporization of a California Naphtha

From true b p curve wt %	Normal boiling-points			
	Feed exptl [t] ° F	Vapour exptl [t] ° F	as ideal sole* ° F	empirically† ° F
0	180	122	180	
5	240	220	227	225
10	268	251	253	253
20	295	278	281	280
30	320	300	301	300
40	335	319	321	320
50	350	331	334	332
60	370	348	347	345
70	387	363	365	361
80	408	383	383	381
90	437	415	410	414

* Using K as from Fig 11

† From Fig 15

or 38% of the feed. From the distillation curve of the feed this is found to be 332°F.

The results for the quality of vapour determined in this manner are compared with the experimental results, and those computed by the theoretical method, in Table III. The agreement in this case is better than may usually be expected.

Although the equations and methods of calculation have been illustrated with vaporization problems, it should be apparent that they may be applied equally well to condensation problems.

Differential Vaporization.

Instead of a flash or continuous equilibrium vaporization, the process may be one of differential vaporization in which the vapour is removed as rapidly as it is formed. In differential vaporization the liquid loses and the distillate gains a differential quantity of material so that

$$(L-dL)(x-dx) + (y+dy)dL = Lx,$$

neglecting differentials of the second order. Integrating between the initial and final quantities of total liquid and the initial and final mole fractions of a component in the liquid

$$\ln \frac{L_1}{L_2} = \int_{x_2}^{x_1} \frac{dx}{y-x},$$

and since $y = Kx$

$$\ln \frac{L_1}{L_2} = \frac{1}{K-1} \ln \frac{x_1}{x_2} \quad (18)$$

In equation (18) K is not constant, since temperature or pressure must vary to produce the differential vaporization. This requires the use of an equivalent average value of K which usually may be taken as the arithmetical average of the values of K at the initial and final temperatures. If the final temperature is not known, it may be assumed and later checked by the bubble-point of the final liquid.

For differential condensation, V and y may be substituted for L and x .

An alternate form of equation (18) is based on the use of total moles (or weights) of individual components rather than on mole fractions (or weight fractions). This equation has the form

$$\ln \frac{a_1}{a_2} = \frac{K_a}{K_b} \ln \frac{b_1}{b_2}, \quad (18a)$$

in which

- a_1 = total moles of component a in initial mixture,
- a_2 = " " " " a in final mixture,
- b_1 = " " " " b in initial mixture,
- b_2 = " " " " b in final mixture.

Again the values of K_a and K_b are not constant, but the ratio, K_a/K_b , is very much less sensitive than K_a or K_b to change in temperature, so that this ratio calculated at the initial temperature may often be used over the whole range of temperature encountered during the vaporization. The ratio K_a/K_b is called the relative volatility of components a and b .

Counter-current Vapour-liquid Processes

The enrichment of the vapour in more volatile components and of the liquid in less volatile components by means of partial vaporization and condensation has been indicated above. Although a satisfactory separation may be eventually be secured by successive equilibrium vaporiza-

tions of the residual liquid followed by successive equilibrium vaporizations of the condensate, this method of operation has the prohibitive disadvantages of an excessive use of heat and of a large number of discontinuous distillations.

An apparatus is required in which the successive vaporizations and condensations may be carried out continuously, simultaneously, and with a minimum use of heat. Such an apparatus is the bubble-plate column in which each plate acts simultaneously on the countercurrent vapour and liquid streams as a partial condenser and as a partial vaporizer. Ascending vapours come into intimate contact with cooler liquid so that less volatile components are partially condensed from the vapour and more volatile components are partially vaporized from the liquid. Thus the ascending vapour gains incrementally in more volatile components and the descending liquid in less volatile components.

The operation of such a column depends upon the difference in composition between the vapour and liquid and their relative quantities leaving each plate and upon the number and efficiency of the bubble plates.

The Equilibrium Plate.

Plate efficiency may be defined as the ratio of the separation obtained by an actual plate to the separation effected by some standard plate. The standard plate here employed is the 'equilibrium plate', so defined that all the vapour rising from a plate after contacting the liquid thereon has an average composition that is in equilibrium with the liquid overflowing to the plate below. Such an equilibrium plate affording a single equilibrium contact per plate.

Plates in an actual column, however, usually involve a number of successive contacts per plate. The liquid changes composition progressively as it flows across the plate, so that the vapour flowing through each successive row of caps approaches equilibrium with a liquid of different composition. Even if equilibrium were obtained at each contact, the average composition of the vapour leaving the plate would be considerably different from the composition of the vapour in equilibrium with the liquid overflowing from that plate.

It may be demonstrated (Brewster [2, 1930]) that the successive contact plate, upon which equilibrium is attained at each contact, produces a greater change in the vapour passing through it (i.e. is more 'efficient' under ideal conditions) than does the standard equilibrium plate which involves only a single equilibrium contact.

There is no inconsistency either in theory or practice in an actual column developing plate efficiencies equal to or greater than 100%.

Absorption and Stripping Factors.

The concept of an absorption factor which is an independent function for each component of the mixture to be separated was developed by Kremser [14, 1930], and applied by Souders and Brown [31, 1932] to gas absorbers and oil strippers and by Brown, Souders, Nyland, and Heiler [7, 1935] to gas and gasoline fractionators.

The absorption factor method uses the absorption or stripping factor in a general equation which involves the number of equilibrium plates required to effect the desired change in the terminal concentrations of an individual component.

If the quantities of ascending vapour and descending

liquid are assumed to be constant, a material balance for any one component and around any plate, n , in the column above the feed gives the equation

$$y_{n+1} = y_n + \frac{L}{V}x_n - \frac{L}{V}x_{n-1} \quad (19)$$

When the equilibrium equation, $y = Kx$, and the absorption factor, $A_n = L/K_nV$, are substituted, the equation becomes

$$y_{n+1} = (1 + A_n)y_n - A_n y_{n-1} \quad (20)$$

For the top plate of a column, equation (20) becomes

$$y_2 = (1 + A_1)y_1 - A_1 K_1 x_0$$

For plate 2,

$$y_3 = (1 + A_2)y_2 - A_2 y_1$$

and substituting the value of y_2 from the preceding equation

$$y_3 = (A_1 A_2 + A_2 + 1)y_1 - A_2(A_2 + 1)K_1 x_0$$

This procedure applied to a number of successive plates down the column leads to the general equation

$$y_{n+1} = (A_1 A_n + A_2 A_n + \dots + A_n + 1)y_1 - A_n(A_1 A_n + A_2 A_n + \dots + A_n + 1)K_1 x_0 \quad (21)$$

When the absorption factor, A , is a constant the two right-hand terms each contain a power series in A , and since

$$\frac{A^{n+1} - 1}{A - 1} = A^{n+1} + A^n + \dots + A + 1,$$

equation (21) may be rearranged as

$$\frac{y_{n+1} - y_1}{y_{n+1} - K_1 x_0} = \frac{A^{n+1} - A}{A^{n+1} - 1} \quad (22)$$

Equation (21) is the general equation of the absorption-factor method, in which

y_{n+1} = mole fraction of any component in vapour entering a section of the absorbing or rectifying column,

y_1 = mole fraction of same component in vapour rising from top plate of the section,

x_0 = mole fraction of same component in liquid entering top plate of the section,

K_1 = equilibrium constant for same component at temperature and pressure of top plate of the section,

n = number of equilibrium plates in the section,

$A = L/KV$ = the absorption factor for the same component.

A similar derivation for a section of a column below the feed leads to the equation

$$\frac{x_n - x_m}{x - y_{m+1}/K_m} = \frac{S^{n+1} - S}{S^{n+1} - 1} \quad (23)$$

where x_n = mole fraction of any component in the liquid entering a section of the stripping column,

x_m = mole fraction of same component in liquid overflowing from bottom plate of the section,

y_{m+1} = mole fraction of same component in vapour entering bottom plate of the section,

K_m = equilibrium constant for same component at temperature and pressure of bottom plate of the section,

$S = KV/L$ = the stripping factor for the same component.

In designing equipment to operate on a particular feed material to effect a desired separation it is essential to establish

1 The composition and quantity of the overhead product

- The composition and quantity of the bottom product.
- The quantities of liquid and vapour flowing at each plate of the column
- The number of theoretical plates required
- The plate efficiency, and
- The vapour and liquid capacities of the column

Some of these factors are independent and some are dependent on the other factors. In general they are related through material balances, equilibrium relationships, thermal characteristics of the materials, and factors influencing mechanical design of the column.

The problems involved in the fundamental design of various types of fractionating equipment are considered in detail in Part B.

Design of Gas Absorbers

Fundamental design of an absorber requires a quantitative relationship between temperature and pressure of operation, oil rate, number of plates, properties and composition of the absorption oil, composition of the entering gas, and the desired recovery of gasoline components. Such a relationship is provided by the absorption factor equation (equation 22 of Part A) which is represented graphically by Fig. 17.

Effect of Operating Conditions.

The absorption factor for any component is directly proportional to the oil-gas rate and inversely proportional to the equilibrium constant of that component at the

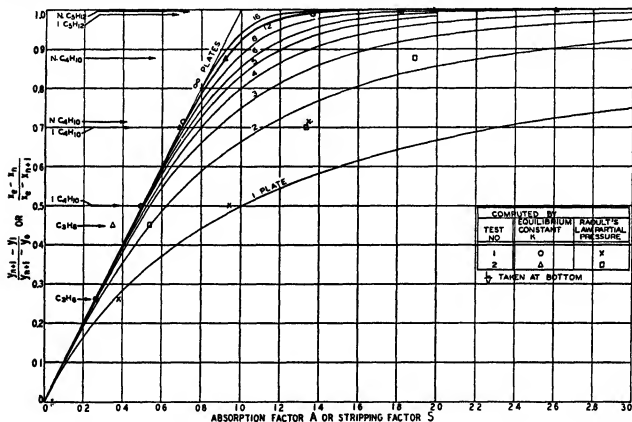

FIG. 17

PART B. METHODS OF CALCULATION AND DESIGN OF FRACTIONATING EQUIPMENT

Selection of the process and conditions of operation to provide the maximum economic return on the capital invested is a primary function of design. Such fundamental design usually involves an economic balance between fixed and operating costs of the process on the one hand, and net realization from the sales of the product on the other hand.

To be useful in comparing costs and selecting from alternative designs, the methods of calculation must be reasonably simple, readily applied, and sufficiently accurate for engineering purposes. Because of these requirements, laboriously extended calculations from plate-to-plate in a fractionating column are not suitable for design purposes.

effective temperature and pressure of operation. Since K varies widely among different components, although the operating conditions remain constant, the absorption factor will have a different value for each component. This equation 22 may be applied to any single component or, in turn, to all of the components in the gas mixture.

For a constant oil rate the absorption factors A for the different components are inversely proportional to the corresponding equilibrium constants K . Therefore fixing the relative absorption of any one component determines the absorption factors for all components. This fact has been used in constructing Fig. 18 which indicates the relative absorption of the gasoline components as a function of the relative n -butane absorption for various numbers of equilibrium plates in the column and for low pressures at 80° F. Inspection of this figure will indicate the effect on the relative absorption of the different com-

ponents, obtained by varying the number of equilibrium plates or other operating conditions

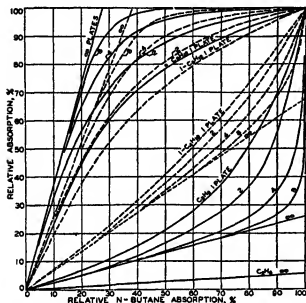

FIG 18 Relative absorption of gasoline components at 80° F

Temperature and Pressure.

Temperature and pressure affect the absorption factor through the equilibrium constant K . Since a minimum lean-oil temperature permits a minimum oil rate with a fixed value for the absorption factor, adequate facilities for cooling the lean oil are of major importance in the economical operation of the plant. With absorbers operating at high pressures or upon rich gases it is often advantageous to use a heat-exchanger between sections of the absorber to remove the heat of absorption and thus obtain a lower operating temperature of the absorption oil.

In general, increase in the operating pressure decreases the oil rate required, although higher pressures increase the oil temperature because of the greater quantity of material absorbed.

At high pressures the equilibrium constants and absorption factors for the various paraffin hydrocarbons are less widely separated than at low pressures. This effect reduces the selectivity of absorbers operated at high pressures, so that, as is found in practice, more plates are generally used for the same or equivalent absorption at high than at low pressures.

Number of Plates.

Fig 17 illustrates the importance of employing an adequate number of plates in the absorber. With a constant value of the ordinate, or recovery of any component, it is apparent that the value of the absorption factor required increases with a decreasing number of equilibrium plates. This increase is large when the number of plates is small but becomes almost negligible with more than 16 equilibrium plates.

If substantially complete recovery of one component is required, the percentage recovery of the more volatile components will be decreased by using a larger number of plates. For example, recovering 99% of the pentane (Fig. 18), a single plate absorber will recover 88.3% of the propane, an 8-plate absorber 11.4%, a 16-plate absorber

8.7%, and an absorber with an infinite number of plates will recover 7% of the propane. The increase in the selectivity of the absorption process with increase in the number of theoretical plates indicates a frequent advantage in the use of a large number of plates.

Properties of Absorption Oil.

The absorption factor is directly proportional to the specific gravity and inversely proportional to the molecular weight of the absorption oil. In general the molecular weight of absorption oil increases with the gravity of the oil but at a relatively greater rate than the gravity. The use of an oil of relatively low molecular weight appears to be advantageous. On the other hand, the stripping operation becomes more difficult and more expensive the lower the molecular weight of the oil. In the design of new plants the choice of the absorption oil requires a consideration of both the absorption and the stripping operations as well as the price of various oils. In operating plants the choice of the absorption oil is largely limited by the performance of the existing stripping equipment.

Stripping of Lean Oil.

The effect on the absorption process of the concentration of gasoline components in the oil entering the absorber is expressed by the term, $K_1 x_0$, of equation 22. x_0 is the mol fraction of a component in the lean oil entering the absorber. An examination of equation 22 indicates that the larger x_0 becomes, the larger must be the absorption factor A , and since A is proportional to the oil rate the larger must be the oil circulation, if the percentage recovery of the component is to be kept constant. Increase in the oil circulation to compensate for insufficient stripping of the lean oil, however, cannot be continued indefinitely since $K_1 x_0$ cannot exceed y_1 , and $K_1 x_0$ can equal y_1 only with an infinite number of plates. The recovery efficiency of the absorption process is usually limited by the gasoline content of the lean oil.

Frequently the only data available regarding the composition of the lean oil is its vapour pressure. Usually the lean oil may be assumed to be effectively stripped of butane and lighter components. If the vapour pressure at 100° F of the lean oil is assumed to be due to pentane, the mol fraction of pentane in the lean oil may be expressed by the equation

$$x_0 = 0.00125 p,$$

where x_0 = the mol fraction of pentane in the lean oil,
 p = the vapour pressure in millimetres of mercury of the lean oil at 100° F

Evaluation of Absorption Factor.

In engineering practice it is customary to express the liquid-gas ratio, L/V , in U.S. gal of oil per 1,000 standard cu ft of gas measured at 60° F and 14.7 lb per sq in abs. Since the volume of a pound mol of gas is 379 std cu ft., and the weight of 1 U.S. gal of oil is 8.33 x 4 lb

$$A = \frac{L}{KV} = \frac{3.156 dG}{KM},$$

where G = oil per 1,000 std cu ft of gas, U.S. gal.
 d = specific gravity of absorbent oil (at 60° F),
 M = molecular weight of absorbent oil

The basic assumption in the derivation of the absorption factor relationship is that " A " is constant, i.e. oil and gas

quantities and oil temperatures are constant throughout the absorber. When this assumption does not approximate closely the actual conditions in the absorber operation, such adjustments must be made in evaluating the absorption factor as will provide an equivalent, mean absorption factor for use in the calculations.

Low Pressure, Lean Gas. Low-pressure absorbers operating on lean gases closely approximate constant oil-gas rates and constant temperatures throughout the absorber. For this reason it is usually more convenient to use the oil and gas quantities entering the absorber for determining the oil rate and to use the temperature of the oil as the mean effective temperature of the absorber. The latter assumption is sufficiently accurate, unless the temperature of the gas is quite different from that of the oil.

Low Pressure, Rich Gas. In low-pressure absorbers operating on rich gases the increase in the quantity of oil due to the absorbed components must be considered in evaluating the absorption factor. Due to difficulties in obtaining a properly weighted average, it is recommended that the oil-gas rate at the bottom of the column be used. Fig 19 shows the results of computations in which the change in liquid from plate to plate was computed and used in a rigorous plate-to-plate calculation on actual terminal conditions of an absorber operating at 45 lb per sq in gauge pressure on a rich gas. The actual absorber contains 10 plates which were found to be equivalent to the 5 equilibrium plates shown in the figure, thereby indicating an overall plate efficiency of 50%. Fig 19 shows the composition of the liquid and vapour on each plate, and the temperature of the oil on each plate.

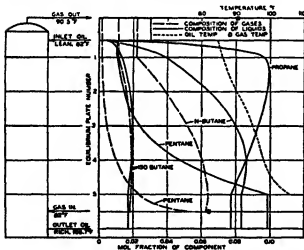

FIG 19 Temperature and composition distribution in low-pressure absorber

The mean effective temperature is practically the arithmetic average of the inlet and outlet oil temperature. The temperature of the oil leaving the absorber may be estimated from plant data or calculated from the latent heat of absorption of the absorbed components. In the absence of operating data this requires the assumption of a mean effective temperature for preliminary determination of the quantity of material absorbed. The temperature of the outlet oil is then calculated on the basis of the latent heat of the absorbed components. The mean effective temperature can then be determined more accurately, and a second calculation of the absorber is usually sufficient to obtain satisfactory check results.

Since the heat of absorption of a component of the gas in the absorber is usually not the same as the latent heat of condensation of the pure component at the same temperature, ordinary values for latent heats of pure components should not be used in making heat balances on absorbers, strippers, or fractionating columns. A correct value for the heat of absorption may be obtained by application of the van't Hoff equation

$$\frac{\partial \log K}{\partial T} = \frac{\Delta H}{RT^2}$$

to the actual equilibrium constants such as are plotted in Figs 2-10 for ideal solutions. Reduced to common logarithms as plotted and substituting 198 for R and solving for ΔH ,

$$\Delta H = \frac{4.67^2}{\partial T} K \cdot 4.67^2$$

If a ruler is placed tangent to the curve at the desired temperature and pressure and the ΔT read between $K=1$ and $K=10$

$$\Delta H = \frac{4.67^2}{K_{x=10} - K_{x=1}} B \text{ Th U per lb mol}$$

High Pressure. High-pressure absorbers include those operating at all pressures over 100 lb per sq in, and require special treatment in some respects. Because of the relatively high absorption of the more volatile components at high pressures, the oil-gas rate at the bottom of the column should be used in determining the absorption factor. In calculating the quantity of oil at the bottom of the absorber the equilibrium constants of the more volatile components should be corrected for deviations from ideal solutions according to Fig 12.

At low pressures the solubility of the methane and ethane is almost negligible and usually need not be considered.

Perhaps the most difficult factor to estimate in designing high-pressure absorbers is the mean effective temperature to be used in determining the absorption factor. Because of the relatively large amounts of methane and ethane

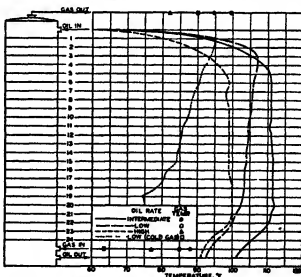

FIG 20 Liquid temperature gradient in high-pressure absorbers

absorbed at high pressures in the upper part of the absorber, it is not possible to calculate the average temperature. For this reason it is necessary at present to rely upon experience in estimating the mean effective temperature.

Usually the mean effective temperature under such conditions may be taken as about 15° F higher than the temperature of the entering gas. Fig 20 shows the actual temperature distribution in absorbers operating at 470 lb gauge pressure (Brown and Souders [4, 1932]). In this figure the plates are actual plates, and the temperatures actual measurements of the temperature in the liquid overflow from each plate.

The complete test data from these absorbers operating with different oil rates serve as an excellent indication of the accuracy of the results obtained from the use of the equilibrium constants as compared with those computed by the assumption of Raoult's law.

Actual measurements on a 24-plate absorber operating at 470 lb per sq in gauge, in which the mean effective temperature was 105° F., show that 57.5 std cu. ft. of gas were dissolved in 5.95 U.S. gal of lean oil per 1,000 std cu. ft. of inlet gas. The lean oil had a molecular weight of 161 and a specific gravity of 0.8363.

The mols of rich oil at the bottom of the absorber per 1,000 std cu. ft. of inlet gas were

$$\frac{57.5}{379} \div \frac{5.95 \times 8.33 \times 0.8393}{161} = 0.409,$$

and the molal oil/gas ratio L/V at the bottom,

$$\frac{L}{V} = \frac{0.409 \times 379}{1,000} = 0.155 \text{ mols rich oil per mol inlet gas}$$

The mol fraction of normal butane in the inlet gas was 0.0166, in the outlet gas 0.0047, and in the lean oil zero. For normal butane at 485 lb per sq in abs and at 150° F., the equilibrium constant K is 0.22 (from Fig 6)

$$\frac{y_{n+1} - y_1}{y_{n+1} - y_0} = \frac{0.0166 - 0.0047}{0.0166 - 0} = 0.717,$$

$$A = \frac{L}{KV} = \frac{0.155}{0.22} = 0.705$$

These values are the coordinates of a point plotted on Fig 17.

The results of similar calculations for all components above ethane are also plotted in Fig 17. The same absorber when operating with an oil/gas ratio of 6.82 U.S. gal per 1,000 cu. ft. provided additional points. With the exception of a single point for propane, which is without doubt due to an error in analysis, all of the calculated points fall almost exactly on the curve for 12 equilibrium plates, indicating an apparent overall efficiency of 50%.

The results of conventional calculations based on Raoult's and Dalton's laws are also indicated for purposes of comparison. Not only do such calculations indicate unreasonably low plate-efficiency of about 8 to 12%, but they are inconsistent among themselves.

This comparison clearly shows that Raoult's and Dalton's laws may not be used for calculating high-pressure absorbers, but that the use of the equilibrium constants as outlined above gives reliable results consistent with actual operating data.

Application to Design Problems.

The absorption factor method is particularly useful in the design of new plants since it permits the quantitative estimation of the factors entering into the economic balance. Application of the absorption factor method to design problems is illustrated by the following examples.

Optimum Number of Plates. Ten million cu. ft. per day

of a gas containing 5.2 mol % of *n*-pentane are to be processed to recover 45% of the *n*-butane and substantially all of the pentane. Price considerations require the use of an absorption oil of 37.1 API and 180 molecular weight. The absorber is to be operated at 85 lb per sq in gauge and 80° F. The lean oil may be expected to contain 0.191 mol % of pentane and negligible amounts of other gasoline components. It is desired to find the optimum number of plates in the absorbers.

It is probable that the economical number of equilibrium plates will lie between 8 and 16. The capital and operating costs may be based on 8 plates and the optimum number of plates determined by balancing the sales realization from the increased recovery of pentane against the cost of the additional plates.

For *n*-butane with 8 equilibrium plates,

$$\frac{y_{n+1} - y_1}{y_{n+1} - K_1 x_0} = 0.45,$$

and

$$A (\text{butane}) = 0.45 \quad (\text{from Fig 17})$$

For pentane, $x_0 = 0.00191$

$$K_1 x_0 = 0.137 (0.00191) = 0.000262$$

$$A (\text{pentane}) = \frac{0.417}{0.137} \times 0.45 = 1.37$$

$$\frac{y_{n+1} - y_1}{y_{n+1} - K_1 x_0} = 0.977 \quad (\text{from Fig 17})$$

Since $y_{n+1} = 0.052$, and $y_1 = 0.00142$, the percentage of pentane recovered with 8 plates,

$$\frac{y_{n+1} - y_1}{y_{n+1}} = 0.973 \text{ or } 97.3\%$$

The lean-oil rate in U.S. gal circulated per 1,000 std cu. ft. of inlet gas

$$G = \frac{KAM}{3 \cdot 156d} \frac{1.37 \times 180 \times 0.137}{3 \cdot 156 \times 0.8393} = 12.8 \text{ U.S. gal per } 1,000 \text{ cu. ft.}$$

Although the rich-oil rate should be used if possible with rich gases, the use of a high overall plate efficiency of 75% will compensate for use of the lean-oil rate.

Since the inlet gas contains 5.2 mols of pentane per 100 mols of gas, 10,000,000 cu. ft. per day will make available to the plant on the basis of 300 days' operation per year

$$\frac{10,000,000 \times 5.2 \times 72.09 \times 300}{379 \times 100 \times 5.262} = 5,640,000 \text{ U.S. gal pentane per year.}$$

With 8 plates 97.3% or 5,486,000 U.S. gal pentane will be recovered per year.

If the absorption factor and oil rate are maintained substantially constant and the number of plates increased, the percentage recovery of butane will remain constant but the percentage recovery of pentane will increase.

The net realization from the sale of the additional pentane recovered, after deducting sales, handling, and stabilizing costs is 4 cents per U.S. gal. The cost for the addition of one actual plate to the proposed absorbers is \$675. Using an apparent overall plate efficiency of 75%, to compensate for the use of the lean-oil rate instead of the rich-oil rate, the annual cost for one additional equilibrium plate will be \$900.

The summary of the calculations for the economic balance with 8, 10, 12, and 16 plates in the absorbers appears in Table IV.

TABLE IV
Optimum Number of Plates

No equilibrium plates	8	10	12	16
% <i>n</i> -butane	45	45	45	45
<i>A</i> (<i>n</i> -butane)	0.45	0.45	0.45	0.45
<i>A</i> (<i>n</i> -pentane)	1.37	1.37	1.37	1.37
$\frac{y_{n+1}-y_1}{y_{n+1}-K_1 x_0}$ (pentane)	0.977	0.988	0.994	0.997
y_1 (pentane)	0.00142	0.00085	0.00055	0.00038
$\frac{y_{n+1}-y_1}{y_{n+1}}$ (pentane)	0.973	0.984	0.989	0.993
Annual pentane recovery, gal	5,486,000	5,548,000	5,580,000	5,598,000
Increase over recovery with 8 plates, gal		62,000	94,000	112,000
Realization, dollars		\$2,480	\$3,760	\$4,490
Cost of added plates, dollars		\$1,800	\$3,600	\$7,200

It appears that the optimum number of plates to return the additional investment in one year is about 12 equilibrium plates or 15 actual plates of 76% plate efficiency.

By means of similar calculations the optimum temperature to which the lean oil should be cooled may be determined by balancing the cost of cooling against the increased pentane recovery, or against decreased oil circulation with the same recovery. Or the cost of more thorough stripping may be balanced against the increased recovery, or against the decreased oil circulation with the same recovery. Or the cost of more thorough stripping may be balanced against the increased recovery, or against the decreased oil circulation with constant recovery.

Increase in Oil Rate. Preliminary calculations on a proposed absorber with an oil rate of 39.1 U.S. gal per 1,000 std. cu ft of raw gas indicate that the plant would recover the maximum quantity of butane that could be marketed. If a greater oil rate is to be used, the cost of any increase in oil circulation must be met by increased realization from natural gasoline alone.

The natural gasoline may contain a ratio of butane to pentane of 0.4. The net realization from the sale of additional product is \$0.04 per gal. The operating cost of oil circulation, including heating, stripping, cooling, and pumping, is \$0.0333 per year per gal of oil circulated per day.

With the oil rate of 39.1 U.S. gal, for pentane $A = 2.81$

$$\frac{y_{n+1}-y_1}{y_{n+1}-K_1 x_0} = 0.996$$

$$y_1 = 0.0017$$

and the percentage recovery of pentane

$$\frac{y_{n+1}-y_1}{y_{n+1}} = 0.9673.$$

Since the mol fraction of pentane in the inlet gas is 0.052, the total available pentane is

$$\frac{1,000 \times 0.052 \times 72.09}{379 \times 5.262}$$

$$= 1.88 \text{ U.S. gal per 1,000 cu. ft per day,}$$

$$\text{or } 564 \text{ U.S. gal per 1,000 cu. ft per year}$$

$$\text{of 300 days.}$$

If the absorption factor for pentane be increased to 3.0, $G = 41.8 \text{ U.S. gal per 1,000 cu. ft}$

$$\frac{y_{n+1}-y_1}{y_{n+1}-K_1 x_0} = 0.997$$

$$y_{n+1} = 0.0052$$

$$K_1 x_0 = 0.0015$$

$$y_1 = 0.00165$$

and

$$\frac{y_{n+1}-y_1}{y_{n+1}} = 0.9682$$

The annual increased recovery of pentane is

$$564 (0.9682 - 0.9673) = 0.508 \text{ U.S. gal}$$

per 1,000 cu ft of gas per day

The total annual increase in natural gasoline recovered is $0.508 \times 1.4 = 0.7112 \text{ U.S. gal per 1,000 cu ft of gas per day}$ and the increased realization from sale of the product is $0.7112 \times 0.04 = \$0.028448$ per 1,000 cu ft of gas per day.

The annual increased operating cost due to the increased oil circulation is $0.0333 (41.8 - 39.1) = \$0.09$ per 1,000 cu ft of gas per day.

To secure a larger recovery of pentane by increasing the oil rate is unprofitable.

High-pressure Absorber. An absorber operating at 470 lb per sq in gauge is to treat 11,084,000 std cu ft of gas entering at 77° F, with lean oil of 161 molecular weight and 0.8363 sp gr. The lean oil, supplied at 65° F, may be expected to be free of isopentane and the more volatile components and to contain 0.0073 mol fraction of *n*-pentane.

It is desired to recover 99.9% of the isopentane in the rich gas with 12 equilibrium (24 actual) plates.

The mean effective absorbing temperature is taken as 93° F.

For isopentane, since $y_b = 0$

$$\frac{y_{n+1}-y_1}{y_{n+1}-y_b} = 0.999,$$

so that from the curve for 12 plates on Fig. 17

$$A = 1.99$$

The absorption factors for the other components may be calculated from the absorption factor of isopentane, since the absorption factors vary inversely with the equilibrium constants.

From the known absorption factors, composition of the lean oil, analysis of the inlet gas, and the curve for 12 plates on Fig. 17, the mols of each component absorbed from the gas may be calculated. These calculations are summarized in Table V.

In an actual test under these conditions 6.82 U.S. gal of lean oil per 1,000 std cu ft of inlet gas were circulated.

Design of Oil Strippers

The factors involved in the design of stripping units include the compositions of rich and lean oils, the number of plates required, the properties of the absorbent oil, the steam consumption in heating and stripping, and the water consumption in cooling and condensing. The design of the stripping unit is closely related to the design of the absorption unit so that the selection of optimum conditions for the complete recovery plant usually requires an economic balance between absorption and stripping costs.

The stripping column usually consists of two sections. The bottom section is the stripping section in which the oil is stripped of gasoline components, and the top section

TABLE V
Design Calculations for High-pressure Absorber
Base 11,084,000 standard cubic feet inlet gas per day
12 equilibrium plates

Component	Mol fraction in inlet gas y_{n+1}	Mols per day in inlet gas	Vapour in equilibrium with lean oil at 65° F $K_1 x_n$	Equilibrium constant K at 93° F and 485 lb Abs	Absorption Factor A at 93° F and 485 lb Abs	$\frac{y_{n+1} - y_1}{y_{n+1} - K_1 x_n}$	Percent absorbed	Mols per day absorbed
CH ₄	0.8302	24,279	0	2.0 × 3.6	0.0257	0.0257	2.57	624
C ₂ H ₆	0.0841	2,460	0	1.3 × 1.22	0.1166	0.1166	11.66	287
C ₃ H ₈	0.0476	1,392	0	1.2 × 0.53	0.291	0.291	29.1	405
iso-C ₄ H ₁₀	0.0084	246	0	0.27	0.685	0.683	68.3	158
n-C ₄ H ₁₀	0.0166	485	0	0.20	0.925	0.877	87.7	425
iso-C ₅ H ₁₂	0.0061	178	0	0.093	1.99	0.998	99.98	178
n-C ₅ H ₁₂	0.0016	47	0.0000285	0.071	2.61	0.999	98.6	46
C ₆ H ₁₄ +	0.0054	158					98.6	156
Total		29,245						2,289

Using the absorption factor and equilibrium constant for *n*-butane, the molal oil/gas ratio at the bottom of the absorber

$$\frac{L}{V} = KA = 0.20 \times 0.925 = 0.185 \text{ mols rich oil per mol inlet gas}$$

$$29,245 \times 0.185 = 5,410 \text{ mols rich oil per day}$$

$$2,289 \text{ mols absorbed per day}$$

$$3,121 \text{ mols lean-oil per day required}$$

The gallons of lean oil required per 1,000 std cu ft of inlet gas

$$G = \frac{3,121 \times 161}{11,084 \times 8.33 \times 0.8363} = 6.52 \text{ lean-oil rate required, U S gal}$$

is the fractionating section in which the vaporized absorbent oil is fractionated out of the recovered gasoline

If temperature, pressure, and the quantities of liquid and vapour may be assumed to be constant throughout the stripping section, the stripping factor relationship represented by Equation 23 is applicable. Usually the assumption of constant pressure and temperature is sufficiently accurate. The assumption of constant quantities of liquid and vapour, however, may be erroneous because the relative increase in the mols of vapour from the bottom to the top of the column may be much greater than the relative increase in the mols of liquid, particularly when the mols of gasoline components stripped from the oil are large relative to the mols of stripping steam.

Although the assumption of constancy in the quantities of liquid and vapour may not be strictly accurate, any error introduced into the result by this assumption will usually be on the safe side. That is, the stripping factor method applied to conditions at the bottom of the column will determine the maximum steam consumption or the maximum number of theoretical plates required. For comparing the effect of varying the operating conditions and for calculating economic balances, the facility afforded by the stripping factor method usually far outweighs the inaccuracies introduced by errors in the basic assumptions.

Effect of Operating Conditions.

Temperature and Pressure. Temperature and pressure affect the stripping factor through the equilibrium constant K . Thus high temperature and low pressure provide a minimum quantity of stripping steam required for a fixed value of the stripping factor.

The highest attainable oil temperature is usually desirable, since the steam consumption for heating is practically constant, regardless of the oil temperature, because most of the heat is recovered by exchangers. Usually the maximum oil temperature is limited by the steam pressure economically available.

Although a low pressure is desirable in stripping, the pressure employed must be sufficient to condense an optimum quantity of overhead material in the presence of fixed gases. The optimum quantity to be condensed will depend upon whether the vapours are recycled, recompressed, or vented.

Number of Plates. Fig. 17 illustrates the importance of employing an adequate number of plates in the stripping column. For constant recovery of any component, it is apparent that the required value of the stripping factor, and hence the quantity of stripping steam, increases with decreasing number of equilibrium plates.

Increase in the number of plates also increases the selectivity of the stripping operation. With substantially complete stripping of hexane the percentage of less volatile components stripped (such as the lighter fractions of the lean oil) will be decreased by using a larger number of plates.

Properties of Absorption Oil. The difficulty and expense of the stripping operation increases with the more volatile oils of lower molecular weight. The increased cost is caused not only by the higher steam rate required but also by the larger reflux required to rectify the vaporized fractions of the absorbent oil. All of these effects increase the heat consumption and the cost of condenser operation. Since the properties of the oil which are most advantageous in stripping are detrimental to good absorber operation, the choice of the absorption oil necessarily involves a compromise.

Reheaters. The latent heat of vaporization of the components stripped from the oil is supplied by the sensible heat of the oil, resulting in a drop in temperature of the oil unless heated by some means. In the past, reheaters, when used, usually have been placed on the oil stream flowing from one of the lower plates of the stripper. As most of the vaporization occurs at the top plate when the hot oil is flashed into vapour in the stripper, most of the temperature drop of the oil occurs between the

entering oil and the overflow from the top plate. Thus the logical location for the reheater appears to be between the first and second plates of the stripping section.

Burdick [8, 1929] has obtained test data on the operation of a stripper still with and without a reheater. His results support the qualitative conclusion that the location of the reheater ordinarily should be between the first and second plates of the stripping section.

In many cases, however, the high-pressure steam which would be supplied to a reheater may be used to greater advantage as additional open or stripping steam. Although expansion of the steam down to the pressure of the stripper results in decreasing the temperature of the steam, the increase in the ratio L/V frequently produces a net advantage.

Evaluation of Stripping Factor.

Ordinarily steam is used for stripping, so that y_{n+1} , the mol fraction of a component in the vapour entering the stripper, equals zero and the stripping equation reduces to

$$\frac{x_n - x_m}{x_n} = \frac{S^{n+1} - S}{S^{n+1} - 1} \quad (23a)$$

In this case the ordinate read from Fig. 17 represents the fraction of the original content of the oil which is removed by the stripping operation.

In practice it is customary to express the steam required for stripping as pounds of steam per U.S. gal of oil. If W represents the pounds of steam per U.S. gal of oil,

$$S = \frac{KV}{L} = \frac{KMW}{150d}$$

where M = molecular weight of absorbent oil,

d = specific gravity (at 60° F) of absorbent oil

The steam-oil rate as determined for the bottom of the stripper is used in determining the stripper factor. The effective stripping temperature is also the temperature existing at the bottom of the stripper. This bottom temperature may be calculated from the latent heat of the material vaporized in the stripper. This material includes not only the gasoline components stripped from the oil, but also some of the absorbent oil itself. This may be computed by use of the stripping factor method, considering the light ends of the absorption oil as one component or, preferably, assuming three or four components to represent the absorption oil based upon the distillation curve of the oil. The values for the equilibrium constants of these components may be determined from Fig. 11 in the manner which has already been described.

Application to Design.

The design of the stripping unit must usually be developed in connexion with the design of the absorption unit. The quantity of oil required for absorption depends in part upon the completeness of stripping and the design of the stripping unit depends in part upon the quantity of oil and the completeness of stripping. Cost of pumping, heating, and cooling of the oil depend largely on the quantity of oil circulated. Economical design usually requires a balance between absorption, pumping, and heating and cooling costs, and stripping, stripping steam and condensing costs. The absorption factor and stripping factor methods provide means for relating the various factors in these costs.

Example It is desired to calculate the steam consumption per gallon of oil W in a stripper having 6

theoretical plates, operating at 60 lb per sq in abs and 300° F. The molecular weight of the oil is 180, the specific gravity 0.839, and the pentane content is to be reduced from 9.84 to 0.191%.

$$\frac{x_n - x_m}{x_n} = \frac{9.84 - 0.191}{9.84} = 0.9806$$

From Fig. 17 the stripping factor for 6 plates and ordinate of 0.9806,

$$S = 1.66 = \frac{KMW}{150d}$$

$$W = \frac{150dS}{KM} = \frac{150 \times 0.839 \times 1.66}{2.95 \times 180}$$

$$\rightarrow 0.394 \text{ lb steam per U.S. gal of oil}$$

Example It is desired to determine the most economical oil rate for an absorber of 8 and a stripper of 6 theoretical plates when 96% of the iso-pentane is recovered from a gas containing 2.1% of iso-pentane. The absorbent oil has a molecular weight of 180 and a specific gravity of 0.839. The unit annual capital and operating cost of oil circulation is \$0.24 per gal of oil per day. The capital and operating cost of stripping and condensing is \$0.0008 per lb of stripping steam.

For the absorber (at 75 lb and 90° F, for iso-pentane $K_A = 0.265$)

$$\frac{y_{n+1} - y_1}{y_{n+1}} = 0.96$$

Since $y_{n+1} = 0.021$, therefore

$$y_1 = 0.00084$$

$$x_n = \frac{V}{L}(y_{n+1} - y_1) + x_0$$

Since $\frac{L}{V} = K_A A$,

$$x_n = \frac{1}{0.265A}(0.021 - 0.00084) + x_0 = x_0 \text{ for the stripper oil rate}$$

$$G = \frac{AMK_A}{3 \cdot 156d} = \frac{180 \times 0.265 \times A}{3 \cdot 156 \times 0.839} = 18A$$

For the stripper (at 60 lb and 300° F, for iso-pentane $K = 3.33$) the pounds of stripping steam per gal of oil

$$W = \frac{150dS}{KM} = \frac{150 \times 0.839 \times S}{3.33 \times 180} = 0.21S$$

x_0 for the stripper equals x_0 for the absorber

Table VI summarizes the calculations for the economic coordination of the absorbing and stripping units. The annual costs of oil circulation and stripping and the sum of these two costs are plotted against the oil circulation. For the present example the minimum point on the curve of total cost is at about 23.5 U.S. gal per 1,000 std cu. ft., which quantity represents the optimum oil rate.

In the above example the temperature and number of plates in absorber and stripper were fixed and only one component, iso-pentane, was considered. The optimum temperatures, number of plates, and oil circulation, as well as the ultimate recovery of other gasoline components, may be determined by similar calculations.

Venting and Flashing of Rich Oil. When the saturation of the oil leaving the absorber is high, the rich oil frequently is passed through a vent tank in which the pressure is reduced and vaporization of some of the absorbed material takes place. Also an appreciable quantity of vapour

usually is formed in the heater through which the rich oil is passed before entering the stripper. Under these conditions the concentration of pentane and heavier absorbed components in the oil entering the stripper cannot be assumed to be equivalent to the concentration in the oil leaving the absorber.

TABLE VI
Coordination of Absorbing and Stripping Units
Basis 1,000 cu ft of inlet gas per day

x_0 Composition of the lean oil (K 80° F = 2.22)	0.00007883	0.0002455	0.0004901	0.0008554	0.0018982
$K_1 x_0$ at 80° Composition of vapour in equilibrium with lean oil	0.0000175	0.000545	0.001088	0.001899	0.0004214
$y_{n+1} - y_1$ $y_{n+1} - K_1 x_0$ for absorber	0.9608	0.9625	0.9650	0.96876	0.97966
A Absorption factor	1.25	1.26	1.275	1.30	1.40
G Oil rate gal per 1,000 cu ft in- let gas	22.3	22.68	22.95	23.4	25.2
x_0 Composition of rich oil	0.060939	0.060623	0.060157	0.059374	0.056238
$x_1 - x_0$ x_0	0.9987	0.9959	0.99185	0.9856	0.96625
S Stripping factor	2.79	2.25	1.97	1.77	1.475
M Lb stripping steam per gal oil	0.5859	0.4725	0.4137	0.3717	0.3098
Annual cost of oil circulation, dollars per year	5.40	5.443	5.508	5.616	6.048
Annual cost of stripping, dol- lars per year	3.164	2.572	2.276	2.088	1.874
Total annual cost, dollars per year	8.564	8.015	7.786	7.704	7.922

The composition of the oil leaving the vent tank or heater may be calculated by applying a rearrangement of equation (9) developed in Part A for equilibrium vaporization,

$$x_0 = \frac{z}{1 + V(K-1)} \quad (9a)$$

where z = mol fraction of any component in oil entering the vent tank or heater,

x_0 = mol fraction of same component in oil leaving the vent tank or heater;

K = equilibrium constant of same component at temp. and press. of vent tank or heater,

V = mols vapour formed per mol of entering oil

If the mols of the absorbent oil vaporized in the vent tank are assumed to be negligible,

$$V = \frac{\sum z - \sum x_0}{1 - \sum x_0}$$

These two equations are solved by trial and error methods. V is assumed in the first equation and the assumed value is checked by the second equation.

In the case of the heater it is usually permissible to

make a simplifying assumption which facilitates the estimation of the pentane content of the oil. If the mols of vapour V formed in the heater are assumed to be equal to the sum of the mol fractions in the feed z of all the components lighter than iso-pentane, the mol fractions of iso-pentane and n -pentane in the oil leaving the heater (i.e. entering the stripper) may be estimated directly. When pressures of from 30 to 75 lb per sq in abs are employed in the stripper, the error introduced by this assumption is usually less than 5% of the mol fraction of pentane. This simplification should not be applied in calculating the concentrations of lighter components nor used with a material balance.

The Fractionating Section.

The function of the fractionating section of the stripping unit is to separate the vaporized absorption oil from the overhead gasoline fractions. Because of the high volatility of the overhead materials and reflux, the equilibrium temperature at the top of the column usually falls below the dew-point of steam in the mixture so that a large part of the stripping steam condenses in the column. Water traps are provided for the plates near the top of the column to remove the condensed steam.

Because the heat content and quantity of the reflux depend on the quantity of steam condensed in the column and upon the top temperature, which in turn are influenced by the quantity and composition of the reflux, the calculations for the fractionating section become very complex.

Simple, straightforward methods for calculating the fractionating section are not available, and it is still necessary to resort to the trial-and-error method, in which the composition of the overhead and the amount of steam condensed is assumed, the heat balance is then made on the basis of an assumed top temperature, thereby fixing the reflux ratio with the material balance. A recalculation is then made to check the quantity of steam condensed. If this agrees with the assumed value, the calculations are considered satisfactory, otherwise, a second trial is necessary.

The usual practice in design has been to establish the number of plates in the fractionating section and the facilities for handling the water condensed in the column on the basis of operating experience rather than on the basis of the very laborious step-wise calculations.

Number of Plates for Gas and Gasoline Fractionators

General Equations.

By making heat and material balances around various parts of the column several general equations may be developed.

A material balance around the complete column leads to

$$F_2 + F_1 = F = D + B, \quad (24)$$

and for any one component

$$a_1 = a_2 + a_3 \quad (25)$$

or $x_1 F_1 + y_1 F_2 = x_2 D + x_3 B$ (25a)

A material balance around the overhead product and any plate above the feed plate gives

$$V_{n+1} = L_n + D, \quad (26)$$

and for any one component

$$y_{n+1} V_{n+1} = x_n L_n + x_D D \quad (27)$$

A material balance around the bottom product and any plate below the feed plate leads to

$$\bar{V}_m = \bar{L}_{m-1} - B, \quad (28)$$

and for any one component

$$y_m \bar{V}_m = x_{m-1} \bar{L}_{m-1} - x_B B \quad (29)$$

Similar equations derived from heat balances are

$$F_2 h_F + F_r H_r = D_2 h_D + D_r H_D + Q_c + B h_B - Q_o, \quad (30)$$

$$V_{n+1} H_{n+1} = L_n h_n + D_2 h_D + D_r H_D + Q_o, \quad (31)$$

and

$$\bar{V}_m H_m = \bar{L}_{m-1} h_{m-1} + Q_c - B h_B \quad (32)$$

The preceding nine equations assume only that there are no losses of either heat or material from the fractionating system and are generally applicable

The Operating Equations.

For practical purposes, the assumption that L and V are constant throughout the rectifying section and that \bar{L} and \bar{V} are constant throughout the stripping section is almost essential for convenient treatment of complex mixtures. This assumption is of much more general application than Trouton's rule which is usually given as the basis for the assumption and which merely states that the ratio of molal latent heat to absolute temperature, at the atmospheric boiling-point, is a constant for many different substances in the pure state. Even when Trouton's rule does not apply, as near the critical temperature of a component, the assumption of constant L and V may be valid. For closely related substances, such as the components in the feed to a natural gasoline stabilizer, the assumption is substantially correct.

Assuming constant quantities of liquid and vapour, equations (27) and (29) for each component become

$$y_{n+1} = \frac{L}{\bar{V}} x_n + \frac{D}{\bar{V}} x_D \quad (33)$$

$$\text{and} \quad y_m = \frac{L}{\bar{V}} x_{m-1} - \frac{B}{\bar{V}} x_B \quad (34)$$

Also with this assumption, several equations may be written relating the quantities of liquid or vapour flowing in the stripping section to the quantities of liquid or vapour in the rectifying section and the condition of the feed

$$\bar{L} = L + U, \quad (35)$$

$$\text{and since} \quad V = L + D, \quad (36)$$

$$\bar{L} = V - D + U \quad (37)$$

$$\text{Also} \quad \bar{L} = \bar{V} + B, \quad (38)$$

$$\text{so that} \quad \bar{V} = L + U - B, \quad (39)$$

$$\text{or} \quad \bar{V} = V + U - F, \quad (40)$$

$$\text{where} \quad U = \frac{F(H_F - H_D) + F_2(H_F - h_r)}{H_F - h_f} \quad (41)$$

When the feed is all liquid at the temperature of the feed plate, $F_2 = F$ and $U = F$, so that $\bar{V} = V$ and $\bar{L} = L + F = V + B$

When the feed is all vapour at the temperature of the feed plate, $F_r = F$ and $U = 0$, so that $\bar{L} = L$ and $\bar{V} = L - B = V - F$

An additional relationship is available from the fact that the sum of the mol fractions of the individual components in any mixture is equal to unity

Equations 33 and 34 may be regarded as operating lines

for the individual components on a y, x plot such as Fig. 15 (McCabe and Thiele [21, 1925]). The slope L/V of each of the rectifying operating lines, equation (33), is identical for all components, but the intercepts $(D/F)x_B$ vary with the individual components. The slope \bar{L}/V of the stripping operating lines, equation (34), which also is constant for all components, is related to the slope of the rectifying lines through equations (35) to (40)

Adding equations (33) and (34) for component a , and using equations (35) and (40) to eliminate L, V, \bar{L} , and \bar{V} , yields the linear equation

$$(F-U)y_a + Ux_a = a_r = y_{a,r}F_r + x_{a,r}F_2, \quad (42)$$

in which y_a and x_a are common solutions for the rectifying and stripping operating lines and give the locus of the intersection of the two operating lines. When the feed is all liquid at the temperature of the feed plate the intersection lies on the vertical line $x = x_F$. When the feed is all vapour at the temperature of the feed plate the intersection lies on the horizontal line $y = y_r$. For a feed which is a mixture of liquid and vapour equation (42) becomes

$$y = -\left(\frac{F_2}{F_r}\right)x_a + y_{a,r} + \left(\frac{F_2}{F_r}\right)x_{a,r} \quad (42a)$$

Equation (42a) is the equation of a line on the y, x plot having the slope $-F_2/F_r$ and passing through the point $x_{a,r}, y_{a,r}$

The coordinates of the point of intersection of the two operating lines for component a are given by the equations

$$x_a = \frac{a_r + \left(1 - \frac{L}{\bar{V}}\right)(U - F)x_{a,r}}{\left(\frac{L}{\bar{V}}\right)F + \left(1 - \frac{L}{\bar{V}}\right)U} \quad (43)$$

$$\text{and} \quad y_a = \frac{\left(\frac{L}{\bar{V}}\right)a_r + \left(1 - \frac{L}{\bar{V}}\right)Ux_{a,r}}{\left(\frac{L}{\bar{V}}\right)F + \left(1 - \frac{L}{\bar{V}}\right)U} \quad (44)$$

If the reflux returned to the column has the same composition as the distillate, the rectifying operating line intersects the line $y = x$ on the vertical line $x = x_n$. Similarly if the vapour returned to the column has the same composition as the bottoms, or if the reboiler is assumed to be the bottom theoretical plate of the column, the stripping operating line intersects the line $y = x$ on the vertical line $x = x_m$.

Minimum Reflux. In the special case of minimum reflux (i e infinite plates) the two operating lines intersect at a point on the equilibrium curve which is the equilibrium of the feed plate. Thus equations (43) and (44) give the concentrations of each component in the liquid and vapour leaving the feed plate when the reflux is a minimum. The minimum value of the ratio L/V may be determined as the value, in equations (43) or (44), necessary to make the sum of the mol fractions of all the individual components in the liquid or vapour leaving the feed plate equal to unity.

Methods of Calculation.

Underwood [35, 1932] is recommended for an excellent critical review of various methods of calculation

Since a binary mixture represents the simplest problem in fractionation, most of the methods proposed for calculating the number of plates have dealt with the separation of binary mixtures

According to the phase rule, for a system of two phases

there are as many degrees of freedom (i.e. independent values of temperature, pressure, and concentration) as there are components in the system. In a binary system, which has two degrees of freedom, fixing the pressure and the concentration of one component in either phase defines completely the temperature and the equilibrium compositions of the vapour and liquid phases. Hence the phase-compositions (y, x diagram) are independent of the vapour/liquid ratio or the number of equilibrium plates and the binary mixture is essentially a special simple case of the general problem of fractional distillation.

Multicomponent mixtures present two fundamental difficulties which are not present with binary mixtures. First, since there are more than two degrees of freedom, fixing the total pressure and the concentration of one component in a phase is not sufficient to define the temperature and phase-compositions, the y, x diagram is not a unique function of the system. Second, the quantities or concentrations necessary for a complete material balance cannot be chosen arbitrarily as with a binary mixture. For a given feed the variables involved in a material balance are the concentrations of all components in the distillate and bottoms and the total quantities of distillate and bottoms. If the number of components is C , there are $2C+2$ variables in a complete material balance for which $C+2$ independent equations may be set up. These independent equations include a material balance equation for each component, and two equations which express the fact that the sum of the mol fractions in the distillate and the sum of the mol fractions in the bottoms each equals unity. With $2C+2$ variables and $C+2$ independent equations, C variables remain to be fixed.

In nearly all cases only two or three components appear in significant concentrations in both distillate and bottoms. Thus it may be assumed that components more volatile than the distributed components have zero concentration in the bottoms and that components less volatile than the distributed components have zero concentration in the distillate. For all practical purposes this assumption is equivalent to fixing the concentration of each of these undistributed components in the distillate or bottoms, as the case may be. By fixing in addition as many variables as there are distributed components, the C independent variables required for a material balance may be established.

There seems to be some confusion among writers on distillation regarding the choice of variables in establishing conditions for design calculations. For a given feed the variables involved include the operating pressure, the ratio L/V , the number of equilibrium plates, and the quantities and concentrations of distillate and bottoms, a total of $2C+5$ variables. There is a single, but complex, independent relationship among number of plates, L/V , and compositions of the products, and $C+2$ independent equations based on material balances, making a total of $C+3$ independent relationships or equations. Thus only $C+2$ variables may be arbitrarily fixed, and they must be selected within limits consistent with a material balance and with the fundamental principles of column operation.

To establish the material balance the components more volatile and less volatile than the distributed components are assumed to be absent respectively from the bottoms and the distillate. Thus the number of independent variables is then equal to two plus the number of distributed components; and all of these are independent only within limits which are more or less restricted, depending upon which of the variables are chosen.

In general the most convenient variables are those with the widest limits, two of which are usually the operating pressure and the ratio L/V . The operating pressure must not be fixed at less than the pressure necessary to produce liquid reflux from the overhead material, nor greater than the critical pressure of the material in the column. The ratio L/V must be greater than the minimum required with infinite plates, and less than unity.

The remaining two or three variables to be fixed in addition to the pressure, L/V , and the zero concentration of undistributed components are selected as conveniently as possible to establish the basis of design. With two distributed components there are two remaining independent variables, and it is theoretically possible to fix, within limits, any of the pairs, (1) quantity of distillate or bottoms and concentration of one component either in the distillate or in the bottoms, (2) concentrations of one component in both the distillate and the bottoms, (3) concentrations of two components either in the distillate or in the bottoms, (4) concentration of one component in the distillate and concentration of the other component in the bottoms. When there are only two significant distributed components the operation must be such as to provide a relatively complete separation of the two distributed or "cut" components. In such operation the important quantities are the small concentration of the less volatile cut component permissible in the distillate, and the small concentration of the more volatile cut component permissible in the bottoms. Hence these two variables are usually chosen as the basis for design.

Similarly with three distributed components there are three remaining variables to be fixed, within limits, from a large number of theoretical combinations. Again the most important quantities are usually the small concentration of the least volatile cut component which may be tolerated in the distillate, and the small concentration of the most volatile cut component which may be tolerated in the bottoms. The third variable to be fixed may be either the quantity of distillate (or bottoms), or the concentration of the intermediate cut component in the distillate (or bottoms). The quantity of distillate (or bottoms) is usually selected because the limits within which the selection must be made are readily determined from a material balance.

The methods proposed by Brown and Souders [5, 1934], Lewis and Matheson [18, 1932], and Underwood [35, 1932, 36, 1933] are among the principal general methods which have been proposed for calculating the number of equilibrium plates required for the separation of mixtures containing more than two components.

Method of Lewis and Matheson. This method is essentially an algebraic plate-to-plate calculation starting from overhead and bottoms compositions employing equations (33) and (34) and (2). Equilibrium compositions at each plate are obtained by trial and error assumptions of plate temperatures until the sum of the mol fractions in each phase is equal to unity. The difficulty of obtaining consistent compositions of overhead and bottoms is minimized by assuming that only two components are distributed in appreciable quantities between overhead and bottoms, that is, none of the more volatile components are present in the bottoms and none of the less volatile components are present in the distillate. This assumption is substantially correct when the separation between two adjacent components is relatively complete, i.e. the mol fraction in the bottoms of the more volatile distributed

component and the mol fraction in the distillate of the less volatile distributed component are each relatively small quantities. In practice, however, this assumption introduces a further difficulty. Calculated compositions for plates above the feed plate include none of the less volatile components, and for plates below the feed plate none of the more volatile components.

To reconcile this inaccuracy it is assumed that there is negligible change in composition between the feed plate and the plate above for more volatile non-distributed components, and between the feed plate and the plate below for less volatile non-distributed components. Under these conditions equation (33) for the more volatile components becomes

$$K_{a_j} x_{a_j} = \frac{L}{V} x_{a_j} + \frac{D}{V} x_{a_D} \\ x_{a_j} = \frac{\frac{D}{V} x_{a_D}}{K_{a_j} - \frac{L}{V}}, \quad (45)$$

and for the less volatile components equation (34) becomes

$$K_{b_j} x_{b_j} = \frac{L}{V} x_{b_j} + \frac{B}{V} x_{b_B} \\ x_{b_j} = \frac{\frac{B}{V} x_{b_B}}{\frac{L}{V} - K_{b_j}} \quad (46)$$

By using equations (45) and (46) to adjust the composition at the feed plate, the calculations may be carried out from the approximated feed plate composition working towards both top and bottom of the column. When difficulties are encountered as the top or bottom is approached the composition of the feed plate is revised, and by successive approximations of the compositions at the feed plate a satisfactory solution may eventually be reached.

The procedure is laborious and as described is limited to conditions where a relatively complete separation is to be made between adjacent components.

Methods of Underwood. Underwood's paper [35, 1932] includes a step-wise method derived from ratios obtained by dividing equation (33) for one component by equation (33) for another component in conjunction with equation for the rectifying section

$$\frac{(L/D)x_{n+1} + x_{nD}}{(L/D)x_n + x_{nD}} = \frac{K_a x_{n+1}}{K_b x_{n+1}} = \gamma_{n+1} \\ \frac{(L/D)x_n + x_{nD}}{(L/D)x_{n-1} + x_{nD}} = \frac{K_a x_n}{K_c x_{n-1}} \\ \frac{(L/D)x_{n-1} + x_{nD}}{(L/D)x_{n-2} + x_{nD}} = \frac{K_a x_{n-1}}{K_c x_{n-2}}$$

Since for every plate $x_a + x_b + x_c = 1$,

$$x_{n+1} = \frac{(L/D)x_n + x_{nD}}{(L/D)N + C} \\ x_{b_{n+1}} = \frac{\frac{K_b}{D}(L/D)x_n + x_{bD}}{L/D + C},$$

where $N = x_{a_n} + \frac{K_a}{K_b} x_{b_n} + \frac{K_a}{K_c} x_{c_n} + \frac{K_a}{K_d} x_{d_n} +$
 $C = x_{a_D} + \frac{K_a}{K_b} x_{b_D} + \frac{K_a}{K_c} x_{c_D} + \frac{K_a}{K_d} x_{d_D} +$

Similarly for the stripping section by equation (34),

$$x_{a_{n+1}} = \frac{\frac{K_a}{K_b} \left(1 - \frac{B}{L}\right) x_{a_n} + \frac{B}{L} x_{a_D}}{N} \\ x_{b_{n+1}} = \frac{\frac{K_b}{K_c} \left(1 - \frac{B}{L}\right) x_{b_n} + \frac{B}{L} x_{b_D}}{N},$$

where $\bar{N} = \frac{K_a}{K_b} x_{a_n} + \frac{K_b}{K_c} x_{b_n} + \frac{K_c}{K_d} x_{c_n} + x_{d_n}$

From the relationships so obtained the compositions on successive plates may be obtained, starting with the liquid on the top plate in equilibrium with the overhead vapour, and with the bottoms, and working towards the feed plate.

By so working down from the top and up from the bottom the feed plate is found as the plate which satisfies the conditions

$$(L/D)x_y + x_{yD} < (L/D)x_{y+1} + (U/F)x_{yD} \\ (L/D)x_y + x_{yD} < (L/D)x_y + (U/F)x_{yD} \\ < \frac{(L/D)x_{y-1} + x_{yD}}{(L/D)x_{y-1} + x_{yD}} = \frac{K_b x_{y-1}}{K_c x_{y-1}} = \frac{y_{b_j}}{y_c} \quad (48)$$

$$\frac{x_{y_j}}{x_{y_l}} > \frac{K_c}{K_b} \frac{(L/D)x_{y+1} + (U/F)x_{yD}}{(L/D)x_{y+1} + (U/F)x_{yD}}, \quad (48 a)$$

in which b and c are adjacent components between which the separation is relatively complete.

The more volatile components which do not appear in the bottoms and the less volatile components which do not appear in the overhead are handled by adjusting the composition of the feed plate as calculated from the top to include the mol fractions of less volatile components as calculated from the bottom.

The minimum number of plates for total reflux is calculated from the equation

$$\frac{x_{b_n}}{x_{a_n}} = \frac{x_{b_1}}{x_{a_1}} \left(\frac{K_b}{K_a}\right)^{n+m+1} \quad (49)$$

in which the exponent $(n+m+1)$ is the total number of plates required for infinite reflux ($L/V = 1$) including the reboiler as one equilibrium plate.

Although Underwood's method is probably the least tedious and the most straightforward step-wise method of calculation which has been proposed, it is too laborious to be wholly satisfactory as a method of design.

A simplified method suggested later by Underwood [36, 1933] employs a modification of equation (47) applied successively to all plates in the section above the feed plate so that for any reflux ratio,

$$\frac{x_{b_j}}{x_{y_j}} = \frac{x_{b_1}}{x_{y_1}} \left(\frac{1}{G}\right)^n, \quad (50)$$

where n = number of plates above feed plate

and $G = \frac{K_b}{K_a} \left(\frac{1 + \frac{x_{cD}}{(L/D)x_{c_n}}}{1 + \frac{x_{bD}}{(L/D)x_{b_n}}} \right)$

Similarly for the section below the feed plate

$$\frac{x_{y_j}}{x_{y_l}} = \frac{x_{y_1}}{x_{y_l}} (J)^m, \quad (51)$$

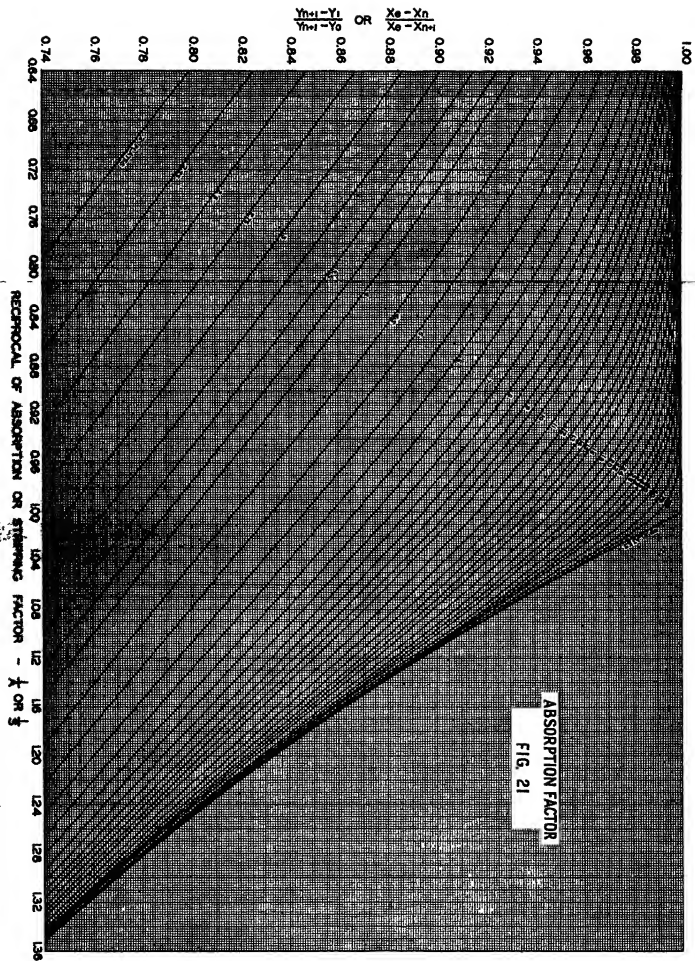

where m = number of plates below feed plate, including the reboiler as one equilibrium plate,

$$J = \frac{K_b}{K_c} \left(\frac{1 - \frac{x_{op}}{(V/B)+1} x_{c(m-1)}}{1 - \frac{x_{bp}}{(V/B)+1} x_{c(m-1)}} \right)$$

The averages of the values of G and J , as calculated for the two terminal plates of each section of the column, are used in equations (50) and (51) respectively.

To apply equations (50) and (51) it is necessary to estimate the temperature of the feed plate by assuming that the ratio of the temperature drop in the rectifying section to the temperature drop in the stripping section is equal to the ratio of the number of plates in the two sections as calculated for total reflux. For total reflux the number of plates in the entire column is calculated by equation (49) and the number of plates above the feed plate is determined as the largest value of n in the exponent $n+1$ which satisfies the relationship,

$$\frac{x_{bp}}{x_{cp}} \left(\frac{K_c}{K_b} \right)^{n+1} > \frac{b_p K_c}{c_p K_b} < \frac{b_p}{c_p}$$

With the temperature of the feed plate so estimated, equations (45) and (46) may be applied respectively to the components more volatile and less volatile than the cut components, b and c , and the sum of the mol fractions of b and c in the liquid overflowing from the feed plate obtained by difference. The limits of the mol fractions of b and c in the liquid at the feed plate are defined by this sum and the relationships (48) and (48a). By assuming that these mol fractions lie midway between the limits, the composition of the liquid at the feed plate may be estimated and equations (50) and (51) may be applied to calculate the number of plates required.

This method is simpler than Underwood's original method because it starts from the feed plate, but is open to the objections that the ratio of number of plates in the two sections of the column may not be independent of reflux ratio and that the mol fractions of the cut components at the feed plate do not necessarily lie midway between their calculated limits.

Recently Gilliland [11, 1935] has suggested that equations (50) and (51) be used in conjunction with the method of Brown and Souders [5, 1934] for calculating the temperature and composition at the feed plate as described in the next column (Absorption Factor Method).

Attempts to apply equations (50) and (51) over the entire column according to the methods outlined by Underwood [36, 1933] and Gilliland [11, 1935] have been unsuccessful with commercial stabilizer test data. Even in those cases for which the calculated number of plates for the entire column was reasonably correct, the calculated location of the feed plate and the relative distribution of plates between rectifying and stripping sections were grossly inaccurate.

Analysis of the results indicates that the assumption of a linear temperature gradient over the entire column, inherent in these methods, is the principal cause of the difficulty. If step-wise equilibrium calculations are made for a few plates down from the top and up from the bottom until the temperature gradients are substantially linear, equations (50) and (51) may be applied with more satisfactory results. It appears, therefore, that the methods outlined

by Underwood [36, 1933] and Gilliland [11, 1935] are subject to the same limitations as the Absorption Factor Method and somewhat less easily applied.

Absorption Factor Method. The application of the absorption factor method to fractionators as developed by Brown and Souders [5, 1934] uses equation (22) or (23) (plotted in Fig. 21) to determine respectively the number of plates required over a section of the rectifying or stripping sections of the column. The method may be applied to one component at a time and is not limited to relatively complete separations between adjacent components.

In setting up the conditions for a design problem for a given complex feed, the variables to be fixed are chosen as indicated on pp 1554-61.

Compositions at Top of Column. If the overhead condenser is a partial condenser, the product which is removed as a vapour may usually be assumed to be in equilibrium with the reflux liquid. Since the vapour from the top plate is made up of the distillate product and the pumped-back reflux, the compositions of these two streams, together with a material balance, suffice to calculate the composition of the vapour leaving the top plate of the column. When the overhead condenser is a total condenser, the vapour rising from the top plate has the same composition as the distillate product. The equilibrium temperature at the top plate may be calculated from the composition of the vapour leaving the top plate.

In many cases the temperature gradient between the plates at the top of the column is not linear. In such cases equations (1) and (3) should be used to compute the compositions and equilibrium temperatures for a few plates below the top until the temperature gradient between successive plates is substantially uniform, to determine a plate which may be used as the top terminal plate for application of the absorption factor.

Compositions at Bottom of Column. The composition of the liquid leaving the bottom plate may be calculated by assuming that the bottoms product is in equilibrium with the vapour entering the bottom plate and by making a material balance around the reboiler or kettle. The temperature difference between successive plates near the bottom is usually far from uniform, and it is advisable to use equations (1) and (34) to compute the temperatures for a few plates until the temperature gradient approaches a linear relationship, to determine the bottom terminal plate for the application of the stripping factor.

Temperature and Compositions at Feed Plate. Since the vapour rising from the feed plate is the feed to the rectifying section, and the liquid overflow from the feed plate is the feed to the stripping section, it is necessary to calculate the compositions at the feed plate. The computed composition of the liquid leaving the feed plate must have as its bubble-point the temperature of the feed plate. In order to fix this composition it is necessary to know the pressure and the ratio, L/V , and to assume a temperature for the feed plate which may be checked by a trial and error process.

For components which do not appear in the bottoms it may be assumed that the mol fraction in the liquid leaving the feed plate is the same as that of the plate above, so that equation (45) may be applied. Similarly, for components which do not appear in the distillate, equation (46) may be used.

When there are three components which appear in significant quantities in both overhead and bottoms, equation (45) may be applied to the most volatile of these

three components if the mol fraction of this component in the bottoms is small and the ratio of the number of plates above the feed to the number below the feed (n/m) is greater than two. The smaller the mol fraction in the bottoms and the larger the ratio of plates, the more applicable is equation (45). Equation (46) may be applied to the least volatile component appearing in both overhead and bottoms if the mol fraction of this component in the distillate is small and the ratio n/m is less than one-third. The smaller the ratio of plates, the more applicable is equation (46).

The mol fractions of all but two components in the liquid leaving the feed plate may usually be determined as described. The mol fractions of the two remaining components may be determined from the estimated temperature of the feed plate and the two relationships (1) sum of mol fractions of all components in the liquid leaving the feed plate is unity, and (2) sum of products of Kx for all components is unity. The equilibrium constants, K_i , are determined from the pressure and temperature of the feed plate, and the two simultaneous equations may be solved for the mol fractions of the two components whose concentrations in the liquid leaving the feed plate are as yet undetermined.

Check for Assumed Temperature of Feed Plate Although a fractionating column may be operated with the feed plate at any one of a number of different locations, in designing a column the feed plate should be located at the point for most effective operation. The feed plate is properly located when relationships (48) and (48a) are satisfied by the concentrations at the feed plate of the most volatile and least volatile distributed components. In designing a column relationships (48) and (48a) provide a means for checking the assumed temperature of the feed plate, since the temperature of the feed plate should be such as to yield compositions which satisfy these relationships.

In several of the illustrative theoretical columns of Table VII the feed plate was purposely mislocated with respect to the cut components in order to check the accuracy of the absorption factor method under adverse conditions. For such cases the assumption of a linear temperature gradient between top and bottom terminal plates is necessary in order to calculate the temperature of the feed plate. With the assumption of a linear temperature gradient the temperature of the feed plate may be calculated from the equation

$$t_f = t_t + \frac{n}{n+m}(t_b - t_t),$$

where t_t = temp of top terminal plate, °F
 t_b = temp of bottom terminal plate, °F

Application of Absorption and Stripping Factors The rectifying part of the column is assumed to act as an absorber of the least volatile distributed component and the stripping part of the column is assumed to operate as a stripper of the most volatile distributed component.

The value of the average or equivalent equilibrium constant, K_a , of the absorption factor, A , for the least volatile distributed component may be taken as the average value between the upper terminal plate, K_u , and the plate immediately above the feed plate, K_{f-1}

$$K_a = \frac{K_1 + K_{f-1}}{2} \quad (53)$$

The temperature of the plate above the feed plate:

$$t_{f-1} = t_f - \frac{1}{n+m}(t_b - t_f)$$

The value of the equivalent equilibrium constant, K_a , for the stripping factor, S , for the most volatile distributed component may be taken as the average value between the plate immediately below the feed plate, K_{f+1} , and the lower terminal plate, K_b

$$K_a = \frac{K_{f+1} + K_b}{2} \quad (54)$$

The temperature of the plate below the feed plate

$$t_{f+1} = t_f + \frac{1}{n+m}(t_b - t_f)$$

Example The application of the absorption factor method to the conditions used in calculating fractionating column 6 of Table VII will serve as an example of the method.

Assuming the temperature of the feed plate to be 166° F and applying equation (46) to n -pentane

$$x_{d1} = 0.233 \times 0.5$$

$$1.233 - 0.324 = 0.1281,$$

$$x_{a1} + x_{b1} = 1 - x_{c1} = 0.8719,$$

$$K_a x_a + K_b x_b = 1 - K_c x_c,$$

$$1.59x_{d1} + 0.738x_{d1} = 1 - 0.324 \times 0.1281$$

$$x_{d1} = 0.5022$$

$$x_{d1} = 0.3697$$

$$y_{d1} = 0.3706$$

Applying the absorption factor to n -butane above the feed plate

$$t_1 = 118^\circ \text{F}, \quad K_1 = 0.435$$

$$t_{f-1} = 153^\circ \text{F}, \quad K_{f-1} = 0.64$$

$$\text{Average, } K_a = 0.537$$

$$A = \frac{L}{K_a V} = \frac{0.9}{0.537} = 1.67,$$

$$\frac{y_f - y_{d1}}{y_f - K_{f-1} x_{d1}} = \frac{0.3706 - 0.04}{0.3706 - 0.435 \times 0.04} = 0.935.$$

From equation (22) (plotted in Fig. 21) 3.8 theoretical plates are required above the feed plate.

Applying the stripping factor to propane below the feed plate

$$t_{f+1} = 179^\circ \text{F}, \quad K_{f+1} = 1.69$$

$$t_b = 242^\circ \text{F}, \quad K_b = 2.29.$$

$$\text{Average, } K_a = 1.99$$

$$S = \frac{K_a V}{L} = \frac{1.99}{1.233} = 1.614$$

$$\frac{z_f - x_{d1}}{x_f - \frac{x_{d1}}{K_a}} = \frac{0.3697 - 0.01719}{0.3697 - \frac{0.01719}{2.29}} = 0.973.$$

From equation (23) (plotted in Fig. 21) 5.7 theoretical plates are required below the feed plate.

Checking the assumed temperature of the feed plate (166° F).

$$t_f = 118 + \frac{3.8}{5.7}(242 - 118) = 167^\circ \text{F}$$

If the numbers of plates above and below the feed plate have been determined by applying the absorption and stripping factors, respectively, to the least volatile and most

volatile distributed components, equations (22) or (23) may also be used to calculate the small concentrations in the distillate, or bottoms, of components which initially were assumed to be absent from these products

Discussion The use of the absorption factor for the design or the calculation of fractionating columns according to the method outlined involves assumptions which can be justified only if they yield reliable results. The estimated composition on the feed plate is not precise, particularly when more than two components are common to, and present in appreciable concentration in, both overhead and bottoms, but is much nearer the actual conditions than the simpler but misleading assumption that the composition of the feed itself might be used for the composition of the feed plate. Although use of the feed composition may give satisfactory results in special cases [6], it is an unsound assumption and should not be used.

If the concentration of the components to which the absorption factor is to be applied goes through a pronounced maximum between the terminal plates, the assumption of an average effective value for the equilibrium constant K as an arithmetic average between the terminal plates may lead to large errors. It appears that this difficulty may be eliminated by separating that part of the column into two sections with a terminal plate located at the maximum concentration of the component or by applying the absorption factor method to a component which does not go through a maximum concentration between the terminal plates.

Comparison of Methods of Calculation For purposes of comparison Brown, Souders, Nyland, and Hesler [7, 1935] set up and computed by step-wise calculations a number of problems involving three-component mixtures of propane, butane, and pentane. Table VII gives a summary of these results and the results on a five-component mixture computed by Underwood [35, 1932]. The results computed by means of the absorption-factor method, using the distillate and bottoms as the terminal conditions, are also included for purposes of comparison.

This comparison of the absorption-factor method with the rigorous step-wise calculation indicates that there are two sources of possible error in the application of the absorption-factor method as described.

1. Errors in the estimated composition of the feed plate, due largely to the improper use of equations (45) and (46). These, or equivalent, assumptions are also employed by all other methods which have been proposed for computing the number of plates for complex mixtures, and errors so introduced are not due to the use of the absorption factor but to these methods for estimating the composition on the feed plate.

2. Errors in the number of plates introduced by applying an arithmetic average for the value of the equilibrium constant K to a component which goes through a maximum composition between the terminal plates. Such errors may be avoided by applying the absorption factor to components which do not pass through a maximum concentration, either by selection of the proper component or by selection of segments of the column to avoid maximum composition between the plates used as terminal plates.

If the column is making a sharp separation between two adjacent components and the feed plate is so located as to accomplish this separation in the most efficient manner, the estimated composition of the feed plate is substantially correct; none of the cut components goes through a maxi-

mum in that part of the column where the absorption factor method would be applied, and the method as outlined may be used with satisfactory results.

If there are to be three distributed components present in appreciable quantities in both the overhead and the bottoms, as in the case of columns 1, 2, and 3, the estimated composition of the feed plate may be in considerable error unless the ratio of plates above the feed plate to the plates below the feed plate is two or more. In any column in which one component is distributed between the overhead and the bottoms—that is, not reduced to a minimum in either the overhead or the bottoms—the component so distributed is very likely to go through a maximum at some point between the terminal plates. Therefore it is necessary to apply the absorption factor method to another component which is not so distributed but is reduced to a minimum in either the overhead or bottoms, as the case may be, in order to obtain reliable results. This was done in columns 1, 2, and 3 by applying the absorption factor method to propane in the stripping section and pentane in the rectifying section.

In many columns that are apparently making a sharp separation between two adjacent components, the feed plate may be so located that in effect the column is actually distributing one intermediate component between the top and the bottom. In such a case reliable results can be obtained only by applying the absorption factor method to another component which is not so distributed. This type of operation is exemplified by column 4 in Table VII in which the composition of the tops and bottoms in respect to propane and butane are the same as in columns 5 and 6. But, owing to the peculiar location of the feed plate in column 4, the column is operating as though it were distributing butane between the overhead and the bottoms. The butane goes through a maximum in the rectifying part of the column and the correct number of plates can be obtained only by applying the absorption factor method to pentane in the rectifying part of the column.

If these difficulties, the equivalent of which are common to all methods, are kept in mind, the absorption factor method as outlined is a convenient and reliable procedure for the design or calculation of the number of equilibrium plates required for the separation of complex mixtures, provided equilibrium may be expressed in terms of an equilibrium constant as for ideal solutions.

Procedure for Design.

The combination of the absorption factor method with the plate-to-plate calculation at the extremities provides reliable information regarding the number of equilibrium plates required and the proper location of the feed plate. The complete procedure to be used in design is illustrated by the following example.

Separation Desired. The feed material of Table VIII is to be fractionated to produce a stable gasoline (bottoms product) which may contain 5.6 mol % (5.09 liquid vol. %) of *iso*-butane, and a distillate which may contain not more than 0.584 mol % (0.65 liquid vol. %) of normal butane. The bottoms are to be withdrawn from the reboiler. The distillate is to be removed as vapour from the overhead separator and all liquid from the separator is to be returned to the column as pumped-back reflux.

Quantity and Composition of Distillate. For convenience the basis of calculation throughout this example will be one mol of feed.

TABLE VII
Comparison of Absorption Factor Method with other Theoretical Methods

Column No.	Component	Feed mol fraction	Distillate			Bottoms			Feed plate					Number of Equilibrium Plates						
			Mol fraction	Temp °F	K	Mol fraction	Temp °F	K	Step-wise absorp. factor	Temp °F	K	$\frac{D}{F}$	$\frac{L}{F}$	Step-wise calcn	Absorp. non factor	Step-wise calcn	Absorp. non factor	Total No. of plates $n+m+l$	Absorp. non factor	
1	Propane	0.3333	0.6567	153	1.46	0.0100	258	2.41	0.109	0.0386	212	2.02	0.5	0.9	3	2.6	2.87	2.3	687	5.9
	Butane	0.3333	0.3333	0.65	0.3333	0.65	0.3333	1.38	0.560	0.7090	1.07	1.07	0.53	0.9	6	6	1.78	1.6	878	8.6
2	Propane	0.1500	0.47667	170	1.62	0.0100	269	2.31	0.0737	0.0334	248	2.33	0.3	0.9	6	6	1.78	1.6	878	8.6
	Butane	0.2500	0.51333	0.76	0.20857	0.76	0.20857	1.45	0.3828	0.3676	1.30	1.30	0.74	0.9	6	5	2.5	2.4	95	9.4
3	Propane	0.2500	0.1667	170	0.62	0.0100	269	2.31	0.0520	0.0200	243	2.28	0.3	0.85	6	5	2.5	2.4	95	9.4
	Butane	0.3500	0.5133	0.52	0.18143	0.52	0.18143	0.86	0.3699	0.3690	0.698	0.698	0.74	0.9	6	3	2.7	2.7	126	11.7
4	Propane	0.3000	0.9299	118	1.10	0.01719	242	2.29	0.1089	0.0936	304	1.04	0.3	0.9	8.6	8.0	3	2.7	126	11.7
	Butane	0.3300	0.0400	0.435	0.48286	0.166	0.48286	1.74	0.6730	0.7038	1.02	1.02	0.49	0.9	8.6	8.0	3	2.7	126	11.7
5	Propane	0.3000	0.9299	118	1.10	0.01719	242	2.29	0.5840	0.5650	144	1.37	0.3	0.9	2.1	2.2	8	7.4	111	10.6
	Butane	0.3300	0.0400	0.435	0.48286	0.166	0.48286	1.74	0.2910	0.3200	0.888	0.888	0.238	0.9	2.1	2.2	8	7.4	111	10.6
6	Propane	0.3500	0.90102	118	1.10	0.01719	242	2.29	0.3736	0.3697	166	1.39	0.3	0.9	3.5	3.8	6	5.7	105	10.5
	Butane	0.3500	0.0400	0.435	0.48286	0.166	0.48286	1.74	0.4820	0.5022	0.738	0.738	0.238	0.9	3.5	3.8	6	5.7	105	10.5
7	Propane	0.3500	0.0223	187.9	0.166	0.48286	285.3	0.692	0.1444	0.1281	0.328	0.328	0.238	0.9	3.5	3.8	6	5.7	105	10.5
	Butane	0.3500	0.9777	0.836	0.90134	0.836	0.90134	0.088	0.0028	0.0028	224.4	2.9	0.5777	0.75	6	5.6	10	10.3	17	16.9
	Hexane	0.210	0.536	0.29	0.431	0.296	0.431	0.362	0.3480	0.356	0.356	0.275	0.75	6	5.6	10	10.3	17	16.9	16.9
	Heptane	0.260	0.466	0.29	0.296	0.296	0.296	0.082	0.0726	0.0726	0.135	0.135	0.275	0.75	6	5.6	10	10.3	17	16.9
	Octane	0.187	0.00006	0.29	0.296	0.296	0.296	0.000	0.0564	0.0564	0.135	0.135	0.275	0.75	6	5.6	10	10.3	17	16.9
	Decane	0.112	0.00006	0.29	0.296	0.296	0.296	0.000	0.0564	0.0564	0.135	0.135	0.275	0.75	6	5.6	10	10.3	17	16.9

* Feed-plate compositions are for liquid on plate. Feed to column 1-6 considered as all liquid and at temperature of feed plate, pressure 200 lb per sq in abs. Feed to column 7, full vapour and half liquid, pressure atmosphere, equilibrium determined by Raoult's law, $K = p/p^*$

If it is assumed that none of the components more volatile than *iso*-butane appear in the bottoms and none less volatile than *n*-butane appear in the distillate,

$$D = 0.1383 + Dx_{10} + Dx_{nD}$$

From equation (25a)

$$Dx_{1D} = x_F - x_B(1-D)$$

so that

$$D = \frac{0.1383 + 0.0805 - 0.0560}{1 - 0.0560 - 0.00584} = 0.1735$$

With the value of D so determined, equation (25a) may be applied to each component of the feed to calculate the complete compositions of distillate and bottoms as presented in Table VIII

Composition of Reflux The pumped-back reflux is assumed to be the liquid in equilibrium with the vapour distillate. On the basis of the ideal solution equilibrium constants (Figs 2-10) the equilibrium temperature is 121° F (at 195 lb per sq in abs) and the reflux composition is as given in Table VIII

Maximum Temperature of Separator. When computing a single equilibrium such as might exist in the separator, the ideal equilibrium constants should be modified according to the deviation factors of Fig 12. The equilibrium temperature computed by the use of such factors was found to be about 115° F, which indicates the maximum temperature which can be tolerated in the separator and should be used to compute the minimum condenser surface and cooling water requirements. Actually a somewhat lower temperature may be required because true equilibrium conditions may not be obtained.

It is also advisable to make an equilibrium computation at the reboiler, or kettle, using these deviation factors in order to calculate the equilibrium temperature required at the reboiler. The temperature so computed, which is lower than that computed by the unmodified ideal equilibrium constants, may be used in most cases for computing heating surface and steam requirements at the reboiler. Although conservative design would suggest the use of the higher temperature, experience indicates that the lower temperature corresponds more closely with actual operating conditions.

In computing the number of plates required for gas and gasoline fractionators it is more convenient to use the equilibrium conditions as computed by the ideal equilibrium constants, and experience indicates that the deviation factors of Fig 12 should not be used.

Quantity of Reflux. The boiler plant can supply to the reboiler, 10,780 B Th U per mol of feed. With 80° F condenser water, the reflux may be cooled to 91° F. The feed is supplied to the column at 213° F, at which temperature the feed is below its bubble-point and thus all liquid. An ideal equilibrium calculation at the reboiler where the liquid is assumed to have the composition of the bottoms product indicates a temperature of 285° F. Equilibrium temperature of the top plate is assumed to be 132° F.

From a heat balance around the stabilizer column,

$$Fh_{213} + Rh_{91} + Q_r = Bh_{285} + DH_{132} + RH_{132}$$

Solving for the quantity of pumped-back reflux

$$R = \frac{Q_r + Fh_{213} - Bh_{285} - Dh_{132}}{(H_{91} - h_{132})R}$$

and substituting heat quantities above a datum temperature of 91° F.,

$$R = \frac{10,780 + 7850 - 0.8265 \times 8724 - 0.1735 \times 7544}{(7718 - 0)}$$

$$= 1.310 \text{ mols per mol of feed}$$

Step-wise Calculations at Top. The quantity and composition of the vapour leaving plate 1 is obtained from the equations

$$V_1 = D + R$$

$$V_1 y_1 = Dx_D + Rx_D$$

An equilibrium calculation with this vapour (Table VIII) indicates that the equilibrium temperature of plate 1 is 132° F (at 195 lb per sq in abs)

From a heat balance around plate 1,

$$V_1 H_1 + L_1 h_1 = Rh + H_4 V_4$$

and since $V_1 = D + R$ and $V_4 = D + L_1$,

$$L_1 = \frac{R(H_1 - h_4) + D(H_1 - H_4)}{(H_4 - h_1)L_1} = \frac{10,110 - 32}{6,775} = 1.489$$

Similar calculations from plate to plate are made until a uniform temperature difference between plates is obtained. The results of these calculations are summarized in Table VIII

Temperature and Compositions at Feed Plate. Preliminary calculations made by assuming a feed-plate temperature, calculating feed-plate compositions and applying equations (48) and (48a), indicate that a feed-plate temperature of 212° F is too low and 214° F is too high. Assuming $t_f = 213° F$ and applying equation (45) to the components more volatile than *iso*-butane and equation (46) to the components less volatile than *normal* butane, the compositions of the vapour and liquid at the feed plate are calculated as presented in Table VIII

Since the feed to the column is all liquid and at the temperature of the feed plate, $V = F$. Applying equations (48) and (48a) to *iso*- and *normal* butane,

$$\frac{(L/D)x_{1F} + (U/F)x_{1D}}{(L/D)x_{nF} + (U/F)x_{nD}} = \frac{(9.125)(0.0805) + 0.197}{(9.125)(0.2551) + 0.0084} = 0.3992,$$

$$\frac{y_1}{y_n} = \frac{0.2226}{0.5335} = 0.4172 > 0.3992,$$

$$\frac{(L/D)x_{1F} + x_{1D}}{(L/D)x_{nF} + x_{nD}} = \frac{(9.125)(0.1723) + 0.197}{(9.125)(0.4863) + 0.00584} = 0.3982 < 0.3992$$

These results indicate that the assumed temperature of 213° F and the corresponding compositions at the feed plate represent conditions required for most effective operation of the column

Step-wise Calculations at Bottom. With the temperature of the feed plate established at 213° F,

$$U = F, \quad \bar{L} = L + U = 2.5817, \quad \bar{V} = V + U - F = 1.7552 \text{ and } (\bar{L}/V) = 1.471$$

Proceeding upward from the reboiler, using equation (34) and the equilibrium relationships, the equilibrium compositions at each plate are calculated until a uniform temperature difference is obtained. The results are shown in Table VIII.

Application of the Absorbing and Stripping Factors. The absorption factor is applied to *n*-butane over the section of the column between the feed plate and plate 5. The temperature of the plate above the feed plate is assumed to be 210° F on the basis of 2 to 4° F temperature drop

per plate above feed, and the equilibrium temperature of plate 6 is 162° F. as computed.

$$K_A = \frac{0.73 + 1.072}{2} = 0.901,$$

$$\frac{1}{A} = \frac{K_A V}{L} = \frac{0.901}{0.901} = 1.00,$$

$$\frac{y_f - y_a}{y_f - K_A x_a} = \frac{0.5335 - 0.0816}{0.5335 - 0.73 \times 0.0896} = 0.9658$$

$$K_B = \frac{1.30 + 1.39}{2} = 1.345,$$

$$S = \frac{K_B \bar{V}}{L} = \frac{1.345}{1.471} = 0.9177,$$

$$\frac{y_f - x_{B-1}}{y_f - K_{B-1} x_{B-1}} = \frac{0.1723 - 0.1530}{0.1723 - 0.1988} = 0.637$$

From Fig 17, 2 equilibrium plates are required in this section

TABLE VIII
Summary of Design Calculations
Basis 1 Mol of Feed

	Feed		Bottoms		Distillate		Reflux		Feed plate	
									Vapour	Liquid
Pressure, lb per sq in Abs	205	200	195	205	200	200	200	200	200	200
Temperature, ° F	231	285	91	91	213	213	213	213	213	213
Quantities										
Mols	1.00	0.8265	0.1735	1.310	1.7552	2.5817				
Pounds	70.08	62.14	7.94	63.52						
U. S. gallons	13.10	11.25	1.85	14.58						
Mol fractions										
CH ₄	0.0010		0.00556	0.00069	0.0006	0.00006	0.00006	0.00006	0.00006	0.00006
C ₂ H ₆	0.0107		0.0616	0.02428	0.0616	0.02428	0.0616	0.02428	0.0616	0.02428
C ₃ H ₈	0.1266		0.7300	0.5403	0.5403	0.1290	0.1290	0.1290	0.1290	0.1290
i-C ₄ H ₁₀	0.0805	0.0560	0.1970	0.3229	0.3229	0.1723	0.1723	0.1723	0.1723	0.1723
n-C ₄ H ₁₀	0.2551	0.3072	0.00584	0.0127	0.0127	0.4863	0.4863	0.4863	0.4863	0.4863
i-C ₅ H ₁₂	0.1084	0.1313				0.0473	0.0473	0.0473	0.0473	0.0473
n-C ₅ H ₁₂	0.0727	0.0883				0.0242	0.0242	0.0242	0.0242	0.0242
C ₆ H ₁₄	0.2037	0.2462				0.0269	0.0269	0.0269	0.0269	0.0269
C ₇ H ₁₆	0.1413	0.1710				0.0080	0.0080	0.0080	0.0080	0.0080

Step-wise Calculation from Top Downward Pressure 195 per sq in abs

Plate No Temperature ° F Phase	1 132 0.896		2 141 0.898		3 148 0.900		4 154 0.901		5 158 0.901		6 162 0.901	
	Vapour	Liquid	Vapour	Liquid	Vapour	Liquid	Vapour	Liquid	Vapour	Liquid	Vapour	Liquid
Mols	1.4835	1.489	1.6625	1.5038	1.6773	1.5632	1.7552	1.5817	1.7552	1.5817	1.7552	1.5817
Mol fractions												
CH ₄	0.00124	0.00014	0.0007	0.00009	0.0007	0.00009	0.00063	0.00007	0.00061	0.00007	0.00061	0.00007
C ₂ H ₆	0.02865	0.0107	0.0160	0.00585	0.1164	0.00412	0.0099	0.00338	0.00915	0.0031	0.0089	0.00296
C ₃ H ₈	0.6510	0.5217	0.5440	0.4000	0.4345	0.3060	0.3482	0.2320	0.2810	0.1904	0.2440	0.1564
i-C ₄ H ₁₀	0.3072	0.4450	0.4190	0.5590	0.5211	0.6390	0.5930	0.6960	0.6454	0.7167	0.6650	0.7300
n-C ₄ H ₁₀	0.01191	0.0225	0.0207	0.0351	0.0320	0.0508	0.0463	0.0691	0.0628	0.0898	0.0816	0.1108

Step-wise Calculations from Bottom Upward Pressure 200 per sq in abs

Plate No Temperature ° F Phase	Reboiler 285 1.471		B-1 255 1.471		B-2 241 1.471		B-3 234 1.471		B-4 230 1.471		B-5 229 1.471	
	Vapour	Liquid	Vapour	Liquid	Vapour	Liquid	Vapour	Liquid	Vapour	Liquid	Vapour	Liquid
Mols	1.7552	0.8265	1.7552	2.5817								
Mol fractions												
i-C ₄ H ₁₀	0.0980	0.0560	0.1334	0.0849	0.1610	0.1087	0.1810	0.1275	0.1988	0.1410	0.2140	0.1530
n-C ₄ H ₁₀	0.4740	0.3072	0.5760	0.4210	0.6220	0.4900	0.6460	0.5207	0.6491	0.5374	0.6424	0.5387
i-C ₅ H ₁₂	0.1444	0.1313	0.1251	0.1402	0.1026	0.1270	0.0818	0.1119	0.0716	0.0980	0.0664	0.0910
n-C ₅ H ₁₂	0.0848	0.0883	0.0671	0.0860	0.0511	0.0740	0.0410	0.0631	0.0353	0.0561	0.0329	0.0523
C ₆ H ₁₄	0.1430	0.2462	0.0774	0.0738	0.0500	0.0812	0.0389	0.1129	0.0347	0.1050	0.0338	0.1025
C ₇ H ₁₆	0.0548	0.1710	0.0921	0.0210	0.0133	0.0691	0.0113	0.0639	0.0105	0.0625	0.0105	0.0625

From Fig 21, 28 equilibrium plates are required in this section.

The stripping factor is applied to iso-butane over the sections of the column between the feed plate and the fourth plate above the reboiler. The temperature of the plate below the feed plate is 214° F., assuming 1° F drop per plate before feed, and of the fifth plate above the reboiler is 229° F., as computed

In addition to an equilibrium condenser and an equilibrium reboiler the column requires 40 equilibrium plates, with introduction of the feed on the 34th plate from the top.

Plate Efficiency. An interesting comparison with the preceding design calculation is provided by a stabilizer of the general Petroleum Corporation, at Santa Fé Springs, California, which was described in the *National Petroleum News*, 26, No 41, 32 (10 October 1934). This stabilizer

was operated under the same pressure and with the same reflux ratio to produce the same bottoms product as that in the design calculation. The vapour distillate product from the stabilizer had a composition intermediate between that of the distillate, and vapour from plate 1, of the design calculation, indicating an overall difference of less than one equilibrium plate between the commercial stabilizer and the design calculation.

The commercial stabilizer was reported as having 38 actual plates. Later inquiry disclosed that the two bottom plates were short-circuited so that the column as operated contained 36 actual plates. Allowing one equilibrium plate for the difference in distillate compositions, the design calculation shows 39 equilibrium plates required, or an overall plate efficiency of 108%. This is practically identical with the plate efficiency obtained by Brown, Souder, Nyland, and Hesler [7, 1935] from a detailed analysis of other commercial stabilizer operating data.

Since the indicated overall plate efficiencies of commercial stabilizers is over 100%, the number of equilibrium plates as computed by the absorption factor method, as described, may be taken as the number of actual plates required, provided such plates are of modern efficient construction.

Caution. The values for the equilibrium constants of the individual hydrocarbons are intended for use in equilibrium calculations between the liquid and vapour phase, only at pressures and temperatures considerably below the critical pressure or temperature of the mixture. This fact must be kept in mind when using these values in the design of fractionating columns, since the numerical values of equilibrium constant K of all components equals unity at the critical point of the mixture, in determining the pressure or temperature at which a fractionating column is to be operated, it is absolutely essential to choose temperatures and pressures below the critical of the material existing in the column. At pressures or temperatures above the critical the material can exist in only one phase, and there can be no equilibrium between two phases and no functioning of the column. The equilibrium constant gives no information as to the critical temperature or pressure of the components or mixtures. This information must be obtained from other sources and given due consideration in studying the operating conditions in the design of fractionators.

Number of Plates for Highly Complex Mixtures

The problem of predicting the number of equilibrium plates required in the separation of highly complex mixtures, such as commercial products of petroleum, has presented so many practical difficulties that the selection of the number of plates has been based largely upon analogy with previous plant experience.

The most general theoretical method of calculation for such mixtures is that proposed by Thiele and Geddes [34, 1933]. In this method both the number of theoretical plates and the heat input are fixed at the start of the computations and the curve of temperature distribution throughout the column is assumed and later modified by successive approximations. An algebraic plate-to-plate calculation based on general heat and material balances, such as equations (27), (29), (30), (31), and (32), is used with the so-called True Boiling Point distillation analysis of the feed, to determine the composition of distillate and bottoms. Although this method is valuable in analysing

operating data, it is usually too tedious to serve as a practical method of design.

The methods of calculation described for gas and gasoline fractionators, which apply to definitely identified components, may also be used with highly complex mixtures by dividing the complex feed into arbitrary components represented by the materials falling within each of a number of successive narrow boiling ranges. The large number of such arbitrary components required, and the relative inaccuracy of the boiling-point analyses of the least volatile materials in a mixture, usually make these methods of calculation difficult to apply.

Obryadchikov [24, 1933] and Peters and Obryadchikov [25, 1933] used a single equilibrium curve (such as Fig. 16), based on the composition of the feed to a fractionating column, in a graphical method similar to that of McCabe and Thiele [21, 1925] to compute the number of plates required to separate the feed into overhead and bottom fractions containing selected percentages boiling below (or above) a chosen cut temperature. Adjustments in the slope of the operating lines, equations (33) and (34), were made at each plate for changes in reflux ratio, and apparently satisfactory results were obtained by a somewhat obscure procedure using Engler distillation data.

Attempts to apply the method, as described, to an entire column on the basis of either A S T M or so-called True Boiling Point Analysis distillation data, however, have been unsuccessful. The difficulty lies in the attempted use of a single equilibrium curve based on the feed composition, which can express accurately the equilibrium conditions only for a mixture with the same composition as the feed. Since the shape of the equilibrium curve depends upon the composition of the material, which differs from plate to plate and at no point is the same as the feed, successful application of this method requires the use of equilibrium curves based upon the composition on the plates where the equilibrium is supposed to exist and not upon the composition of the feed.

Although the method as proposed by Obryadchikov is inadequate, considerable study and experiment with actual column-operating data indicate that, with proper selection of the equilibrium curves and within certain limitations regarding concentrations at the cut temperatures and the number of equilibrium steps, the great facility of the graphical procedure may be combined with a satisfactory degree of accuracy.

The Equilibrium Curve.

The equilibrium curve used in this method is a 'y-x diagram' which is a unique function for each different material. It is based upon the so-called True Boiling Point curve of a complex mixture. The ordinate of each point represents the fraction of the vapour which boils below a corresponding cut temperature on the True Boiling Point curve of the vapour, and the abscissa represents the fraction of the liquid which boils below the same cut temperature on the True Boiling Point curve of the liquid. Fig. 15 is a generalized plot of such equilibrium curves, based on weight fractions, in which the equilibrium curves corresponding to different materials are related to the slopes of the True Boiling Point curves of the materials.

Since the curves of Fig. 15 are generalizations developed from a wide variety of materials, to obtain sufficient accuracy for fractionation problems it is frequently necessary to calculate the equilibrium curves for the particular materials upon which the design is to be based. Such

calculation may be made conveniently by dividing the True Boiling Point curve of the material into a number of arbitrary components each of which represents from 2 to 6 mol % of the total material. The composition of the liquid in equilibrium with a known vapour is obtained by successive approximations of the equilibrium temperature until the sum of the quotients y/K for the arbitrary components is substantially unity, or the composition of the vapour in equilibrium with a known liquid is obtained similarly when the sum of the products Kx is substantially unity. Table IX presents a summary of the calculations of equilibrium curves as applied to analyses of the distillate liquid on intermediate plate 6, and liquid on bottom plate 10 of a naphtha column investigated by Lewis and Smoley [19, 1930]

terminal plate without previous knowledge of the compositions at the intermediate plates.

When there are more than six or eight equilibrium plates in a section there is no assurance that the equilibrium curves for the terminal plates bound the area within which the intermediate equilibrium curves will lie. This difficulty is apparent from Fig 22, on which the three equilibrium curves calculated in Table IX are shown. Here the equilibrium curves for plates between plate 1 and plate 10 lie below the area bounded by the equilibrium curves for plates 1 and 10, although the curves for plates between 1 and 6 and between 6 and 10 lie within the respective areas bounded by the curves for plates 1 and 6 and by the curves for plates 6 and 10. Because of this difficulty it is usually unsatisfactory to proceed from top to bottom of a column

TABLE IX
Summary of Calculations for Equilibrium Curves

Distillate or plate 1				Plate 6				Plate 10 or bottom						
Vapour mol fraction		Liquid mol fraction		Liquid mol fraction		Vapour mol fraction		Liquid mol fraction		Vapour mol fraction				
Cumula- tion	Incr ment v	Avg temp of F	Incr ment v y/K	Cumula- tion	Incr ment x	Avg temp of F	Incr ment y Kx	Cumula- tion	Incr ment x	Avg temp of F	Incr ment y Kx	Cumula- tion		
0			0	0			0	0			0	0		
0.04	0.04	73	0.0065	0.0065	0.01	0.01	201	0.0206	0.0206	0.01	0.01	233	0.0213	0.0213
0.08	0.04	82	0.0075	0.0140	0.02	0.01	207	0.0189	0.0395	0.02	0.01	239	0.0197	0.0410
0.12	0.04	89	0.0082	0.0222	0.04	0.02	211	0.0347	0.0742	0.04	0.02	244	0.0376	0.0786
0.18	0.06	108	0.0166	0.0388	0.06	0.02	216	0.0323	0.1065	0.06	0.02	249	0.0340	0.1126
0.24	0.06	140	0.0279	0.0667	0.08	0.02	220	0.0307	0.1372	0.08	0.02	251	0.0334	0.1460
0.30	0.06	149	0.0329	0.0996	0.12	0.04	225	0.0570	0.1942	0.12	0.04	252	0.0656	0.2116
0.36	0.06	153	0.0348	0.1344	0.16	0.04	228	0.0541	0.2483	0.16	0.04	255	0.0625	0.2741
0.42	0.06	158	0.0381	0.1725	0.22	0.06	231	0.0762	0.3245	0.22	0.06	260	0.0880	0.3621
0.48	0.06	170	0.0451	0.2176	0.28	0.06	237	0.0722	0.3967	0.28	0.06	266	0.0815	0.4436
0.54	0.06	184	0.0575	0.2751	0.34	0.06	241	0.0661	0.4628	0.34	0.06	270	0.0756	0.5152
0.60	0.06	194	0.0675	0.3426	0.40	0.06	244	0.0638	0.5266	0.40	0.06	275	0.0699	0.5891
0.66	0.06	199	0.0711	0.4157	0.46	0.06	246	0.0620	0.5886	0.46	0.06	280	0.0651	0.6542
0.70	0.04	201	0.0504	0.4661	0.52	0.06	249	0.0594	0.6480	0.52	0.06	286	0.0602	0.7144
0.74	0.04	203	0.0524	0.5187	0.58	0.06	252	0.0574	0.7054	0.58	0.06	291	0.0545	0.7689
0.78	0.04	206	0.0537	0.5722	0.64	0.06	255	0.0544	0.7598	0.64	0.06	300	0.0488	0.8177
0.82	0.04	210	0.0582	0.6304	0.70	0.06	258	0.0512	0.8110	0.70	0.06	307	0.0448	0.8625
0.86	0.04	215	0.0627	0.6931	0.76	0.06	262	0.0489	0.8599	0.76	0.06	315	0.0398	0.9019
0.88	0.02	220	0.0352	0.7283	0.82	0.06	269	0.0439	0.9038	0.82	0.06	324	0.0339	0.9358
0.90	0.02	223	0.0368	0.7651	0.86	0.04	276	0.0261	0.9299	0.86	0.04	333	0.0200	0.9558
0.92	0.02	227	0.0391	0.8042	0.90	0.04	281	0.0238	0.9537	0.90	0.04	342	0.0170	0.9728
0.94	0.02	231	0.0411	0.8453	0.94	0.04	287	0.0220	0.9757	0.94	0.04	354	0.0140	0.9868
0.96	0.02	236	0.0453	0.8906	0.98	0.04	300	0.0179	0.9936	0.98	0.04	372	0.0102	0.9976
0.98	0.02	242	0.0510	0.9416	1.00	0.02	320	0.0062	0.9998	1.00	0.02	396	0.0030	1.0000
1.00	0.02	250	0.0586	1.0002										

* K from Raoult's law $P = 764$ mm Hg, vapour pressure at 190° F

† $P = 722$ mm Hg, vapour pressure at 250° F

‡ $P = 778$ mm Hg, vapour pressure at 290° F

For a section of the column consisting of not more than six or eight equilibrium plates, the equilibrium curves computed for the material on the top and bottom terminal plates usually represent the limits of the equilibrium curves for all plates in the section. The composition for the top plate of a section lies on the equilibrium curve for the material on the top plate, and the equilibrium point for the bottom terminal plate lies on the equilibrium curve for the bottom plate, with the equilibrium points for intermediate plates falling between. These intermediate points are selected so as to divide the horizontal or vertical distance between the terminal equilibrium curves into two segments such that the ratio of these segments equals the ratio of the number of plates above to the number of plates below the intermediate plate. By means of a preliminary estimate of the number of plates in the section, it is thus possible to proceed graphically from the upper to the lower

without knowledge or estimation of the composition at one or more intermediate plates. The most satisfactory results are obtained when the method is applied to short sections of the column, such as a section between the distillate and the highest side-stream, sections between the intermediate side-streams, and a section between the lowest side-stream and the bottoms.

Because of inaccuracies in distillation analyses, the method usually becomes uncertain when used with cut temperatures which correspond to more than 97% on the distillation curve at the upper terminal plate or which correspond to less than 5% to 8% on the liquid distillation curve for the lower terminal plate.

It should be noted that although each equilibrium curve applies to all cut temperatures, each cut temperature used requires a separate operating line, except for total reflux, because the fraction corresponding to the cut temperature

determines the intercept of the operating line. With total reflux all operating lines coincide because all have the intercept $y = 0$

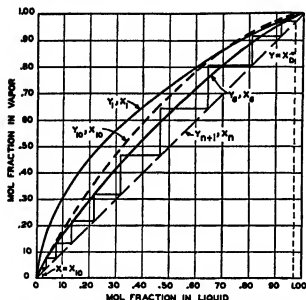

FIG. 22 Equilibrium curves computed by Raoult's law unmodified and graphical calculation of the number of equilibrium plates using cut temperature of 242° F. from distillate to Plate 10 with equilibrium curves for Plates 1, 6, and 10

Graphical Procedure.

Fig. 22 illustrates the method as applied to the naphtha column investigated by Lewis and Smoley [19, 1930], using a cut temperature of 242° F. This cut temperature corresponds to 0.97 mol fraction on the True Boiling Point curve of the distillate and to 0.025 mol fraction on the True Boiling Point curve of the liquid from the bottom plate, plate 10. The column was operated under total reflux, so that the operating line has a slope equal to unity and passes through the origin. The equilibrium curves are those calculated in Table IX.

From the point on the operating line (locus of the points y_{n-3}, x_n) where $y_{n-3} = x_n = 0.97$, the equilibrium points from plate 1 to plate 6, inclusive, are stepped off between the operating line and the area bounded by the equilibrium curves for these terminal plates in the manner previously described. Similarly from the equilibrium point on the curve for plate 6, the plates from plate 6 to and including the bottom plate are stepped off between the operating line and the area bounded by the equilibrium curves for plates 6 and 10 until a horizontal step intersects the vertical line $x = x_{10} = 0.025$. The number of equilibrium points is nine and the last fractional step is equivalent to 0.68 of an equilibrium plate, a total of 9.68 equilibrium plates required. In the actual column in which this separation was obtained by Lewis and Smoley there were ten actual plates, so that the overall plate efficiency appears to be about 97%.

Table X summarizes the results obtained by applying the graphical procedure to a number of different cut temperatures from the same operating data. The average of the number of equilibrium plates required for all cut temperatures is 8.78 plates, or an average overall plate efficiency of 87.8%.

Table IX also presents for comparison the results of

the graphical procedure for the same cut components when using the empirical equilibrium curves of Fig. 15. With the empirical curves the average number of equilibrium plates required is 7.25, or an average overall plate efficiency of 72.5%.

Lewis and Smoley reported individual plate efficiencies for this column of from 80 to 95% when treating this petroleum naphtha, corresponding to an average individual plate efficiency of 87.5%, which is in excellent agreement with the average overall plate efficiency of 87.8% computed by the graphical method.

Since the empirical equilibrium curves are based on weight fractions, the True Boiling Point curves and compositions should represent weight fractions and the slope of the operating line L/V should be calculated from a weight ratio. The Naphtha Column of Lewis and Smoley was operated with total reflux so that the ratio L/V is unity for both the mol basis and the weight basis.

The empirical equilibrium curves used were interpolated from Fig. 15 on the basis of the slopes of the True Boiling Point curves of the materials corresponding to the three terminal plates. The slope of the True Boiling Point curve (weight basis) of the distillate is 1.75 (% per °F), for which the equilibrium curve may be interpolated between the curves of slope 1 and 2 of Fig. 15. The slope for the liquid on plate 6 is 0.62 and the slope for the liquid on plate 10 is 1.05. The equilibrium curve of Fig. 15, which corresponds to a slope of unity, is used for both of these liquids.

Capacity of Columns

The capacity of a fractionating column may be limited by the maximum quantity of liquid that can be passed downward or by the maximum quantity of vapour that can be passed upward, per unit time, without upsetting the normal functioning of the column. The liquid capacity may be limited either by the capacity of the weirs and downspouts or by the resistance to the flow of vapour through the bubble plates. The vapour capacity may be limited either by the resistance to flow through the plates or by the quantity of entrainment that may be tolerated.

Weirs and Downspouts

In order to maintain a suitable liquid-level above the slots in the bubble caps, nearly all columns employ weirs. In the larger columns both inlet and overflow weirs, which are usually straight or rectangular, are provided to aid in the distribution of the liquid over the plate. In the smaller columns the downspout, which is usually a pipe or cylinder, projects above the surface of the plate and serves as the overflow weir, and the seal-pot or well at the base of the downspout represents the inlet weir.

The discharge capacity of standard rectangular weirs is given by the familiar Francis formula

$$Q = 0.0067H^{3/2} \quad (55)$$

in which

Q = discharge, cu ft per sec,

l = length of weir, in,

H = head above edge of weir, in of fluid flowing

The usual type of weir used in fractionating columns is not a standard rectangular weir since it passes through a chord of the plate-circle and is restricted at the back by the shell of the column. If the head over the weir does not exceed the maximum distance from the weir to the shell of

the column, however, equation (55) may be used with reasonable assurance in estimating the capacity of this type of weir

mate the capacity of circular downsouts which have uniform cross-sectional area, since their capacity is usually limited by the quantity of fluid which will enter them

TABLE X
Summary of Graphical Computation of Various Cut Temperatures
Naphtha Column of Lewis and Smoley [19]
From Distillate to Plate 6 (six actual plates)

	Cut temperatures							
	242 F		236 F		229 F		222 F	
	Equal curves from Table VIII	Fault curves from Fig 15	Equal curves from Table VIII	Equal curves from Fig 15	Equal curves from Table VIII	Equal curves from Fig 15	Equal curves from Table VIII	Equal curves from Fig 15
Distillate x_1	0.970	0.960	0.950	0.937	0.920	0.902	0.882	0.862
x_2	0.916	0.880	0.867	0.820	0.804	0.725	0.731	0.642
x_3	0.916	0.880	0.867	0.820	0.804	0.725	0.711	0.642
x_4	0.804	0.705	0.719	0.595	0.623	0.465	0.526	0.380
x_5	0.804	0.705	0.719	0.595	0.621	0.465	0.526	0.380
x_6	0.641	0.4725	0.5325	0.358	0.4195	0.248	0.316	0.194
x_7	0.641	0.4725	0.5325	0.358	0.4195	0.248	0.316	0.194
x_8	0.466	0.275	0.350	0.194	0.250	0.125	0.171	0.096
x_9	0.466	0.275	0.350	0.194	0.250	0.125	0.171	0.096
x_{10}	0.316	0.154	0.218	0.104	0.144	0.065	0.091	0.050
x_{11}	0.316	0.154	0.218	0.104	0.144	0.065	0.091	0.050
x_{12}	0.213	0.081	0.138	0.085	0.085		0.050	
Actual x_{12}	0.311	0.309	0.235	0.220	0.102	0.140	0.080	0.078
y_6 in equi with actual x_6	0.453	0.483	0.343	0.371	0.168	0.2575	0.137	0.149
No equi plates	5.08	3.95	5.05	3.95	5.77	3.98	5.41	4.46
Plate efficiency	85%	66%	84%	66%	96%	66%	90%	74%

From Plate 6 to Plate 10 (if we actual plates)

	Cut temperatures							
	295 F		278 F		265 F		259 F	
	Equal curves from Table VIII	Fault curves from Fig 15	Equal curves from Table VIII	Equal curves from Fig 15	Equal curves from Table VIII	Equal curves from Fig 15	Equal curves from Table VIII	Equal curves from Fig 15
Actual x_1	0.949	0.939	0.860	0.8415	0.760	0.735	0.675	0.661
x_2	0.949	0.939	0.860	0.8415	0.760	0.735	0.675	0.661
x_3	0.8915	0.881	0.760	0.718	0.640	0.570	0.548	0.483
x_4	0.8915	0.881	0.760	0.718	0.640	0.570	0.548	0.483
x_5	0.7815	0.778	0.617	0.549	0.4915	0.388	0.402	0.308
x_6	0.7815	0.778	0.617	0.549	0.4915	0.388	0.402	0.308
x_7	0.6175	0.626	0.447	0.367	0.334	0.233	0.262	0.175
x_8	0.6175	0.626	0.447	0.367	0.334	0.233	0.262	0.175
x_9	0.426	0.445	0.283	0.217	0.2005	0.128	0.153	0.093
x_{10}	0.570	0.535	0.409	0.371	0.235	0.220	0.175	0.1575
x_{11} in equi with actual x_{11}	0.7606	0.717	0.599	0.5525	0.3825	0.3715	0.296	0.280
No equi plates	3.13	3.38	3.11	2.98	3.69	3.11	3.76	3.21
Plate efficiency	78%	84%	78%	75%	92%	78%	94%	80%

For circular weirs where the diameter is greater than four times the head the discharge formula becomes

$$Q = 0.021DH^2 \quad (56)$$

in which D diameter inches

For circular weirs where the diameter is less than $4H$ but greater than $2H$

$$Q = 0.00823D^{2.676}H^{0.893} \quad (57)$$

and where the diameter is less than $2H$

$$Q = 0.0065D^3H^{0.8} \quad (58)$$

Equations (56), (57), and (58) may also be used to esti-

mate the capacity which do not have circular cross-section the capacity may be estimated from the usual orifice formula using a contraction coefficient of 5/6, i.e.

$$Q = 0.008AH^{0.8} \quad (58, a)$$

in which A = cross-sectional area, square inches

Pressure Drop Through Plate.

The resistance to the flow of vapour through a bubble plate is made up of the head of liquid above the top of the slots in the caps and the frictional resistance in the vapour path. The head of liquid above the slots may be estimated

as the sum of the vertical distance from the top of the slots to the edge of the outlet weir plus the head above the weir required to pass the liquid over the weir

The total resistance to the flow of the vapour through a bubble plate is given by the equation

$$H_0 = H_s + H_{ow} + H_f \quad (59)$$

in which

H_0 = total resistance to flowing vapour, in of liquid on plate,

H_s = static seal over slots distance from top of slot to edge of outlet weir, in,

H_{ow} = head over outlet weir in of liquid

H_f = frictional resistance, in on liquid

The frictional resistance to the flow of vapour through the cap is made up largely of eddy losses at the entrance to the riser or vapour uptake at the junction of riser and annular spaces and at the slots. This resistance depends in part upon the mechanical details of the cap. For the usual circular cap of good design in which the horizontal cross-sectional areas of the riser and of the annular space are each approximately equal to one-half the cylindrical area of the free space between the top of the slots and the face of the plate, the frictional resistance may be estimated by the equation

$$H_f = 0.65 \frac{d_v}{d_l} \mu^3 \quad (60)$$

in which

H_f = frictional resistance in of liquid on plate,

d_v = density of vapour,

d_l = density of liquid

μ = velocity of vapour in riser ft per sec

Priming.

Where the total resistance to the flow of the vapour through the plate exceeds the available balancing head of liquid in the downspout, the liquid ceases to flow and the column primes. The priming point represents the ultimate limit of column capacity, and is a function of the quantities of both liquid and vapour flowing, and of the dimensions and mechanical layout of the column and plates

For adjacent bubble plates which are alike mechanically, the maximum head of liquid available to balance the resistance to the flowing vapour may be expressed as

$$H_{max} = H_p - (H_s + H_{ow} + H_{ow}), \quad (61)$$

in which

H_p = distance between plates, in,

H_s = head over downspout, in of liquid,

H_{ow} = head over inlet weir, in of liquid,

H_{ow} = head over outlet weir, in of liquid

The minimum distance between plates for operation of the column without priming may be calculated by equating (59) and (61) and solving for H_p , i.e.

$$H_p = H_s + H_s + H_{ow} + H_{ow} + H_f \quad (62)$$

Because of possible inaccuracies in the assumptions used in calculating the various dynamic liquid heads and because of surging during operation of the column, it is advisable to use 150% of H_p from equation (62), when calculating the minimum spacing between plates or the ultimate capacity of the column, and not less than 200% for the basis of design

Entrainment

The capacity of a column at the priming-point represents the ultimate capacity without regard to the sacrifice of fractionating efficiency which may be necessary to attain this ultimate capacity. The vapour capacity, particularly in petroleum columns, is frequently below the priming-point and is limited largely by the quantity of entrainment that may be tolerated. For this reason, if the column is of good mechanical design and has adequate liquid capacity, vapour capacity is limited by permissible entrainment may be the controlling factor.

In a fractionating column entrainment signifies the upward displacement of liquid particles, from plate to plate, caused by the dynamic action of the vapour. Entrainment may be defined as the quantity of liquid carried upward from plate to plate by the vapour per unit of time, but possesses little quantitative significance unless expressed as a ratio, such as the quantity of entrained liquid to the quantity of vapour rising from a plate per unit of time E/Y , or as the ratio of entrained liquid carried upward by the vapour to liquid overflow from the plate E/L .

The effects of entrainment in fractionating equipment are largely the impairment of colour, loss of liquid overhead as in oil absorbers and decrease in plate efficiency.

The effect of entrainment on colour is most important in flash jugs or chambers without fractionating plates, since a small quantity of dark residual material may have a relatively large effect on the overhead material. In fractionating columns where several plates separate bottoms and overhead the effect of entrainment on colour is less important since each plate acts as an entrainment separator, and the dark material is progressively diluted by the liquid overflowing from plate to plate.

The function of a plate is to change the composition of the vapour rising through the plate. This, in turn depends upon the fact that there is a difference in composition between the liquid and vapour leaving the plate. Entrainment of liquid particles in the vapour stream diminishes the effective difference in composition between the vapour and liquid and decreases the change in composition of the total material (dry vapour and entrainment) rising through the plate. For these reasons entrainment is an important factor in limiting the fractionating efficiency of a plate.

Factors Determining Entrainment.

Entrainment may be regarded as the result of two distinct effects of the flowing vapour, the actual carrying of droplets by the rising vapour and the throwing of liquid particles by the dynamic action of vapour jets. The first effect is a function of the mass velocity of the vapour, the densities of the liquid and vapour and the diameter of the particle which in turn is influenced by the surface tension of the liquid, density of the vapour, and agglomeration of individual particles into larger masses. The entrainment produced by the throwing of liquid particles is a function of the kinetic energy of the vapour jets, which, in turn, depends upon the density and the linear velocity of escape of the vapour, and is closely related to the spacing between plates.

Because of the complex nature of relationships between these numerous variables and the limited amount of quantitative data at present available, it is necessary to adopt elementary simple relationships between the most important variables in order to arrive at a practical solution. In the following treatment it is assumed that the mass

velocity of vapour upwards through the free space of the column controls the quantity of entrainment in the same manner as the upward mass velocity of any fluid is able to suspend solid or liquid particles, depending upon their density and size

Theoretical Suspending Velocity.

The upward velocity of a fluid required to suspend a body in the fluid stream may be determined from the resistance of the body to the moving fluid and the force of gravity on the body

The resistance of a sphere in a moving fluid is given by the expression (37)

$$F_a = K\mu \frac{\pi^{\frac{1}{2}}}{2} Dv + kd_1 \frac{\pi D^3}{4} v^2,$$

where F_a = total force on drop,

K, k = constants which must be evaluated empirically,

μ = viscosity of fluid,

D = diameter of particle,

d_1 = density of fluid,

v = linear velocity of fluid relative to drop

In a fractionating column the first term on the right may be neglected, since the viscosity of the vapour is small (0.01 to 0.001 centipoise), so that

$$F_a = \frac{kd_1\pi D^3}{4} v^2$$

The force of gravity (less buoyancy) on a spherical particle

$$F_g = \frac{\pi D^3}{6} (d_1 - d_2)g,$$

where d_1 = density of particle,

g = acceleration of gravity

When the force of gravity is equal to the resistance to the moving vapour the particle remains suspended,

$$F_a = F_g = \frac{kd_1\pi D^3}{4} v^2 = \frac{\pi D^3}{6} (d_1 - d_2)g$$

and the suspending velocity

$$v = \left(\frac{2gD(d_1 - d_2)}{3kd_1} \right)^{\frac{1}{2}}$$

Since mass-velocity of the vapour $W = 3,600vd_2$ in lb per sq ft per hour,

$$W = C[d_2(d_1 - d_2)]^{\frac{1}{2}}, \quad (63)$$

where C = a factor depending upon conditions,

d_1 = density of vapour, lb per cu ft,

d_2 = density of liquid, lb per cu ft

Practical Application To Entrainment.

Although the value of C in the above derivation is $3,600\sqrt{2gD/3k}$, equation (63) is used to include the effects of other variables than the theoretical suspending velocity, which are incorporated in the factor C

The range of sizes of the liquid particles (D) which comprise the entrained liquid is an indeterminate variable. Particle sizes probably are related to the surface tension of the liquid on the plate, since the dispersion of the spray produced by a bursting bubble appears to vary inversely with the surface tension on the film. Increase in density of the vapour also appears to promote atomization. The

tendency for individual particles to coalesce into larger drops which are less readily entrained may be influenced by surface tension and spacing between plates, or time, which may have a bearing on the probability of collisions between particles

In addition to the carrying of droplets by the rising vapour, entrainment is produced by the jet action of the vapour caused by the contraction of the path of flow through the bubble caps and vapour-liquid mixture on the plate. The throwing of droplets by vapour jets is related to the density and velocity of the vapour flowing through the slots in the bubble caps and the depth of the 'liquid seal'. In general, the penetration of droplets thrown by a jet decreases, and the dispersion increases, with increase of the density of the vapour. With other conditions constant (velocities, densities, surface tension, &c.), it appears that the entrainment due to the throwing of droplets should be influenced largely by the distance between plates

Increasing the velocity of the vapour through a column not only tends to increase the height to which droplets may be thrown but also decreases the free space above the vapour-liquid mixture on the plate. This effect is due to the vapour-lift action of the flowing vapour which raises the froth-level as the velocity is increased

For these reasons, if the limiting vapour velocity causing entrainment is to be expressed by a simple equation such as (63), factor C will depend upon surface tension, distance between plates, and the nature of the materials or service conditions. The numerical values to be used for C in equation (63) can be best determined in an empirical manner

Souders and Brown [32, 1934] analysed the operating conditions of a number of commercial fractionating columns operating at approximately the maximum vapour load compatible with satisfactory fractionation. The operating data include conditions from 0.192 lb per sq in (0.013 to 32 atmo) total pressure, 12 to 30 in plate spacing, and materials from lubricating oils to natural-gas gasoline. In each case the value of factor C corresponding to the maximum capacity of the column was calculated by means of equation (63)

In Fig 23 the values of C thus obtained from fractionating columns are plotted against the centre-to-centre distance between the bubble plates. Points where the surface tension of the liquid on the plates is above 12.7×10^{-4} lb per ft (20 dynes per cm) (plotted as circles) define the solid curve, points where the surface tension is less than 20 dynes suggest the location of the dotted curve for surface tension of 6.85×10^{-4} lb per ft (10 dynes per cm).

Since the values of factor C expressed in Fig 23 are based on data obtained from the upper or fractionating sections of petroleum columns, these values of C should be modified when applied to gas absorbers and probably require modification when applied to columns or strips of columns which are in different services, such as stripping columns

Fig 24 is a chart for evaluating the allowable mass velocity of the vapour in a column from the liquid and vapour densities and the value of C obtained from Fig 23, a graphical solution for equation (63). For example, in a topping column with gasoline overhead, d_1 is 0.094 and d_2 is 39.55 lb per cu ft, so that $d_1(d_1 - d_2)$ is 3.7. With plates spaced at 24 in, C (from Fig 23) is 640, and (from Fig 24) W , the allowable mass velocity of the vapour, is 1,200 lb per sq ft of column cross-sectional area, per hour.

All material comprising the vapour stream (including products, internal reflux, fixed gases, and steam) should be

included when calculating the density of the vapour and the vapour load of the column

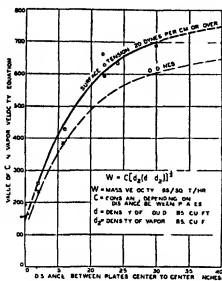

FIG. 23 Effect of plate spacing

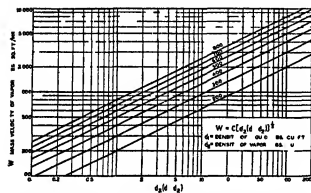

FIG. 24 Chart for evaluating allowable mass velocity of the vapour in a column from the liquid and vapour densities and the value of C from Fig. 1

Quantity of Entrainment.

Data on the quantity of entrainment in bubble plate columns, most of which were laboratory columns, have been reported by Chillas and Weir [9, 1929], Souders and Brown [32, 1934], Holbrook and Baker [12, 1934], Ashraf Cabbage, and Huntington [1, 1934], and Sherwood and Jenny [30, 1935].

Table XI compares the quantity of entrainment, expressed as lb of liquid entrained per lb of dry vapour, as reported by all of these investigators when their columns were operated with the mass-velocity of the vapour as calculated from Fig. 24 and equation (63).

The data of various investigators differ by several hundred per cent even when the reported conditions of operation appear to be comparable. In general, however, the mean quantity of entrainment corresponding to the mass-velocity as calculated from Fig. 24 and equation (63) appears to correspond roughly to about 0.04 lb of liquid per lb of dry vapour.

Ashraf, Cabbage, and Huntington [1, 1934] reported data on the quantity of entrainment carried into the residue gas line of a commercial natural gas absorber. This

column had a 6-ft space between the top plate and the top of the column in which two mist extractors were located. Even in this case the quantity of oil carried out of the column increased with increase in the mass-velocity of the vapour through the column, although from 95 to 99% of

TABLE XI
Comparison of Reported Data on Entrainment

Plate spacing in	C from Fig. 21	W from eq. (63)	Lb liquid entrained per lb dry vapour	River area Column area
12*	260	349	0.006	0.0598
12†	260	561	0.018	0.0865
15‡	410	1,100	0.016	0.0865
15‡	410	1,100	0.055	0.0494
15‡	410	789	0.016	0.05
15.5*	430	636	0.012	0.0598
16‡	450	990	0.07	
18*	545	807	0.042	0.0598
20*	570	844	0.048	0.0598
30‡	700	480	0.045	0.155
31‡	710	1,051	0.034	0.0598

* Holbrook and Baker [12] Steam salt Water System

† Sherwood and Jenny [30] Air water System

‡ Ashraf Cabbage and Huntington [1] Air Kerosene System

§ Chillas and Weir [9] Air water System

|| Souders and Brown [32] Straw oil Semi-commercial Vacuum Column

the entrainment was removed by the mist extractors. By assuming that the quantity of entrainment as measured in the residue gas line was representative of the entrainment from plate to plate within this absorber, Sherwood and Jenny [30, 1935] were misled into concluding that the quantity of entrainment in commercial columns is negligible even at very high vapour velocities.

Although this discussion deals exclusively with plate-fractionating columns, it is well to indicate that much greater entrainment may be expected in other types of equipment which do not contain plates or other types of entrainment separating devices. The actual entrainment in a flash chamber of a cracking plant (chamber free of any entrainment separating device) was observed to be more than twice the entrainment observed in a plate fractionating tower. The vapour-liquid mixture in this case entered the large chamber through a single pipe at high velocity, and the large kinetic energy of this stream was an important factor in increasing the entrainment over that of a plate column, although the stream was directed against the lower end of the side of the chamber.

Entrainment and Plate Efficiency

Defining plate efficiency as the ratio of the actual change in composition of the wet vapour passing through the plate to the change that would take place were the vapour leaving the plate in equilibrium with the liquid overflowing from the plate

$$\text{Efficiency, } e = \frac{y_1 - y_{n+1}}{Kx_n - y_{n+1}} \quad (64)$$

where y_n = mol fraction of a component in mixture of vapour and entrained liquid rising from plate n ,

y_{n+1} = mol fraction of the same component in the mixture of vapour and entrained liquid from plate below plate n ,

K = equilibrium constant = e the ratio between mol fraction in dry vapour and mol fraction in liquid under equilibrium conditions,

x_n = mol fraction of some component in liquid overflowing from plate n

Souders and Brown [32, 1934] derived the general equation for the effect of entrainment on plate efficiency

$$e = 1 - \frac{K(1-f) + \frac{E}{V}(kf-1)}{K - \frac{x_p}{x_n} \left(1 - \frac{L}{V}\right) - \frac{L}{V}} \quad (65)$$

where x_p = composite mol fraction in products withdrawn either (a) above plate n for plates above feed plate or (b) below plate n for plates below feed plate,

f = a factor which represents the degree of approach toward equilibrium between dry vapour and liquid overflow leaving the plate, and is dependent upon a large number of variables, including the mechanical design of the plate,

E = total mols of entrained liquid carried with dry vapour from plate to plate,

V = total mols of mixture of vapour and entrained liquid rising from plate to plate

The factor, f , may usually be taken as unity for gas and gasoline fractionators and columns operating on the more volatile fractions of petroleum if the plates are of good mechanical design

Using an entirely different definition of plate efficiency, Rhodes [28, 1934] has derived a relationship between reflux ratio, entrainment, and plate efficiency which is particularly useful with the McCabe and Thiele [21, 1925] diagram for binary mixtures

Equation (65) may be simplified for special conditions, such as

Equilibrium plate with total reflux

$$f = 1, \text{ and } V/L = 1 \\ e = 1 = E/V \quad (66)$$

Total reflux and no entrainment

$$e = 1 - \frac{K(1-f)}{K-1} \quad (67)$$

Top plate of a column where the reflux has the same composition as the overhead distillate—i.e. $x_{n-1} = y_n$.

$$e = \frac{1 - E/V}{\frac{V(K-Kf)}{L(Kf-1)} + 1 - \frac{V}{E} + \frac{E}{L}} \quad (68)$$

And for a top plate which is an equilibrium plate—i.e. $f = 1$

$$e = \frac{1 - E/V}{1 - \frac{E}{V} \left(1 - \frac{V}{L}\right)} \quad (69)$$

Using the entrainment data of Souders and Brown to compute E/V for different relative velocities and substituting in equation (69), Fig. 25 was constructed giving plate efficiency as a function of relative mass vapour velocity for various values of L/V . From Fig. 25 it is clear that plate efficiency may be maintained constant with a greater mass velocity (greater entrainment) if the value for L/V (ratio of liquid overflow to vapour) is increased accordingly, and if E/V is substantially independent of L/V .

The relationship between plate efficiency, liquid/vapour ratio, L/V , and relative mass-velocity of the vapour as

plotted in Fig. 25 indicates that the probable maximum vapour load or capacity for satisfactory operation as based on plate efficiency varies more or less directly with the liquid/vapour ratio L/V . Therefore it is to be expected

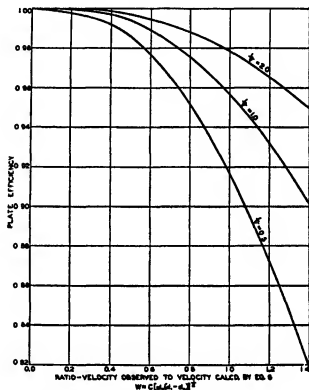

FIG. 25 Effect of vapour velocity on efficiency of top equilibrium plate

that fractionating equipment may be operated satisfactorily at higher capacities when the ratio of liquid to vapour L/V is larger. Thus, greater mass velocity might be tolerated in the stripping sections of stabilizers or steam strippers than in the rectifying sections of the same columns. Similarly, the permissible mass-velocity would be greater at the top of a topping column than at plates immediately above the feed plate, and the upper part of a topping column would be operated with greater mass-velocity of the vapour than the upper or rectifying part of a column for stripping natural gasoline from absorbent oil. This is found to be the case in commercial operation.

It has been assumed in the application of equation (69) and Fig. 25 that E/V is independent of L/V . Actually there is some evidence that E/V may increase with increasing values for L/V , due partly at least to increased submergence resulting in decreased free space between plates. If this effect is appreciable it will tend to minimize the differences in maximum capacity for the different services.

If adequate and reliable data concerning the effect of vapour-velocity on quantity of entrainment and plate efficiency were available, it might be possible to determine the optimum economic relationship among number of actual plates, column diameter, and spacing between plates for each design problem. Without such data, the capacities of columns as calculated from equation (63) and Fig. 24 usually may be used for design purposes with assurance that the quantity of entrainment will not be so

great as to decrease materially the effectiveness of fractionation

Procedure for Design

- 1 From heat and material balances or from L/V ratio, estimate quantities of liquid and vapour at point of greatest load in the column,
- 2 Calculate economic optimum plate spacing and diameter from equation (63) and Fig 23,
- 3 Estimate sizes of weirs and downspouts required, using equations (55) to (58a) and bearing in mind the limitations imposed by the diameter of the column,
- 4 Check the plate spacing by equation (62) to see that priming will be avoided

Nomenclature

- F Moles of feed to column, used as subscript to signify feed
- B Moles of bottom product, used as subscript to signify bottom product
- D Moles of distillate withdrawn as overhead product, used as subscript to signify overhead product
- V Moles of vapour rising from plate in rectifying section, used as subscript to signify vapour phase
- L = Moles of liquid overflowing from plate in rectifying section, used as subscript to signify liquid phase
- R - Moles of reflux, used as subscript to signify reflux
- V Moles of vapour rising from plate in stripping section
- L = Moles of liquid overflowing from plate in stripping section
- $a, b, c, d, \&c.$, refer to moles of individual components of which a is the most volatile, when used as subscript the letters refer to individual components
- x - Mole fraction of any component in the liquid

- y = Mole fraction of any component in the vapour.
- n - Number of theoretical plates above feed plate, used as subscript, refers to any plate in rectifying section
- m Number of theoretical plates below feed plate, used as subscript, refers to any plate in stripping section
- f - feed plate, i, e plate from which the vapour rising becomes the feed to the rectifying section and liquid overflowing becomes the feed to the stripping section, used as subscript refers to feed plate
- 1, 2, 3, &c., refer to the first, second, third, &c., plate of the column, numbering from the top downwards.
- P = Total pressure
- p = Vapour pressure of pure component
- K Equilibrium constant for a particular component
- A L/KV absorption factor for a particular component
- S KV/L stripping factor for a particular component

Heat Quantities

- H - 'Total heat', Enthalpy (above convenient datum temperature) of one mole of vapour
- h 'Total heat', Enthalpy of one mole of liquid
- Q_c Heat quantity removed by condenser in unit time
- Q_r Heat quantity supplied by reboiler in unit time
- U - Increase in quantity of flowing liquid caused by the introduction of the feed This is equivalent to the ratio difference in enthalpy between vapour feed at temperature of feed plate, and feed as delivered to column, divided by mole heat of vaporization, at temperature of feed plate
- $$\frac{F(H_f H_D) + F_D(H_f H_D - h_f)}{H_f - h_f}$$
- T Absolute temperature °F - 1 460
- t Temperature in degrees Fahrenheit

REFERENCES

- 1 ASHRAF, F A, CUBBAGE, T L, and HUNTINGTON, R L *Ind Eng Chem* 26, 1068 (1934)
- 2 BREWSTER, O C *Oil and Gas J* 28, no 46, 41 (1930)
- 3 BROWN, A C, and CAINE, G C *Trans Amer Inst Chem Eng* 21, 91 (1928)
- 4 BROWN, G G, and SOUDERS, M, Jr *Oil and Gas J* 31, no 5, 34 (1933), *Refiner*, 11, 376 (1932)
- 5 ——— *Trans Amer Inst Chem Eng* 30, 438 (1934)
- 6 BROWN, G G, SOUDERS, M, Jr, and NYLAND, H V *Ind Eng Chem* 24, 522 (1932)
- 7 BROWN, G G, SOUDERS, M, Jr, NYLAND, H V, and HESLER, W W *Ind Eng Chem* 27, 183 (1935)
- 8 BURDICK, G F *Proc Calif Nat Gasol Assoc* 4, nos 8, 9, 16 (1929)
- 9 CHILLAS, R B, and WEIR, H M *Trans Amer Inst Chem Eng* 22, 79 (1929)
- 10 CUMMINGS, L W T, STONES, F W, and VOLANTE, M A *Ind Eng Chem* 25, 728 (1933)
- 11 GILLILAND, E R *Ind Eng Chem* 27, 260 (1935)
- 12 HOLBROOK, G E, and BAKER, E M *Ind Eng Chem* 26, 1063 (1934)
- 13 KATZ, D L, and BROWN, G G *Ind Eng Chem* 25, 1373 (1933)
- 14 KREMER, A *Nat Petr News*, 22, no 21, 43 (1930), *Oil and Gas J* 29, no 1, 146 (1930)
- 15 LEWIS, G N *Proc Amer Acad* 37, 49 (1901)
- 16 LEWIS, G N, and RANDALL, M *Chemical Thermodynamics* (McGraw-Hill Book Co. N.Y. 1923)
- 17 LEWIS, W K, and LUKE, C D *Trans Amer Soc Mech Eng* 54, no 17, 55 (1932)
- 18 LEWIS, W K, and MATHESON, G L *Ind Eng Chem* 24, 494 (1932)
- 19 LEWIS, W K, and SHOLEY, E R *API Bull* 11, 73 (1930)
- 20 MATHESON, G L, and CUMMINGS, L W T *Ind Eng Chem* 25, 723 (1933)
- 21 McCABE, W L, and THILLE, E W *Ind Eng Chem* 17, 605 (1925)
- 22 NELSON, W L, and SOUDERS, M, Jr *Petr Eng* 3, no 1, 111 (1931)
- 23 OBYADCHIKOV, S N *Ind Eng Chem* 24, 1155 (1932)
- 24 ——— *Neft Khoz* 24, 129 (1933)
- 25 PETERS, W A, and OBYADCHIKOV, S N *Neft Khoz* 24, 50 (1933)
- 26 PINGOMOV, R S, and BEISWENGER, G A *API Bull* 10, no 2, 52 (1929)
- 27 RAIGORODSKIY, P M, and RECTOR, N K *Nat Petr News*, 24, no 34, 37 (1932)
- 28 RHODES, F H *Ind Eng Chem* 26, 1333 (1934), 27, 272 (1935)
- 29 SELPFEMER, C W, SOUDERS, M, Jr, SMITH, R L, and BROWN, G G *Ind Eng Chem* 24, 515 (1932)
- 30 SHERWOOD, T K, and JENNY, F J *Ind Eng Chem* 27, 265 (1935)
- 31 SOUDERS, M, Jr, and BROWN, G G *Ind Eng Chem* 24, 519 (1932)
- 32 ——— *Ind Eng Chem* 26, 98 (1934)
- 33 SOUDERS, M, Jr, SELPFEMER, C W, and BROWN, G G *Ind Eng Chem* 24, 517 (1932)
- 34 THIELE, E W, and GEODES, R L *Ind Eng Chem* 25, 289 (1933)
- 35 UNDERWOOD, J A V *Trans Inst Chem Eng* (London), 10, 112 (1932)
- 36 ——— *J S C I* 52, 224 t (1933)
- 37 VILLAMIL, R DE, *Resistance of Air* (E and F H Spon, Ltd., London, 1914)
- 38 WATSON, K M, and NELSON, E F *Ind Eng Chem* 25, 880 (1933)

DISTILLATION IN THE REFINING OF PETROLEUM

By W. A. PETERS, Jr., B.A., B.S.

Chemical Engineer, Badger & Sons, Co., Boston, Massachusetts

DISTILLATION may be considered a science so far as it concerns the separation of simple mixtures containing a few components the properties of which are known, but the separation of such a complex mixture as petroleum is rather an art than a science. The great advances made during the past 10 years in petroleum distillation practice have been either through the adoption of some method of distillation used in another industry or through trial of possible methods in the laboratory or plant. Such theory as has been developed has been worked out to explain existing operations rather than to point the way to any great improvements, and this is not because the industry is backward, but because the raw material is extremely complex and the specifications required on the products do not demand separation of individual compounds except in the light ends.

Recently the importance of anti-knock properties of gasoline and viscosity index of lubricating oils has made it desirable to separate petroleum into its component parts. So far the type of separation required can be obtained better by solvent extraction than by distillation methods, and the problems of distillation in the petroleum industry, except as regards the light ends, are still concerned with making roughly separated fractions.

These fractions may be divided into three groups: first, the light ends up to butane or pentane, which are of interest as practically pure compounds—the separation of these is treated in the section on Theory of Separation of Petroleum Hydrocarbons by George Granger Brown and Mott Souder, Jr.; second, the products that are used as fuels or solvents and are specified primarily by boiling range or volatility; third, the products used as lubricating oils, asphalts, &c., which are specified primarily according to viscosity or penetration and for which volatility (flash-point) is of secondary importance. A fourth group might be added of materials useful for their chemical properties, such as benzol or toluol obtained from aromatic crudes, or certain fractions obtained by solvent extraction that may have value as insecticides, &c.

Theoretical methods for calculating the design of fractionating equipment are given by Brown and Souder. These methods are as yet of practical use only in the range of the lighter products. While the method of Underwood [25, 1932] might be used, for example, to determine the relative efficiency of the plates of an operating column from actual test data, it is neither practical nor necessary to work out the design of a column by such a theoretical method where the products are complex mixtures all more or less widely overlapping one another.

Properties of Petroleum Important in Handling Distillation Problems

In addition to the properties mentioned above, namely, boiling range and volatility, viscosity, and penetration, the specific gravity, colour, melting-point, pour-point, and many others may be specified. Fortunately, all of these properties do not have to be determined for each fraction

of a crude petroleum in order to give a practically complete picture of that crude. Almost all crudes are found to have certain properties in common, and the analysis of any unknown crude can be much simplified by determining a few important points and then comparing with known crudes.

Boiling-point Curves

Most important of the properties common to all crudes is that, above the hexanes, they may be considered as consisting of an infinite number of compounds, each one of which differs infinitesimally from those next above and below in boiling-point. From this it follows that if a sample of any crude is distilled by the batch or differential vaporization method, the boiling-points of successive fractions—no matter how small these fractions are within practical limits—may be plotted against the per cent distilled off as a smooth curve. This curve, if the boiling-points were determined in an apparatus with a reasonably good fractionating column, is called the True Boiling-point Curve, abbreviated to T B P curve.

Washburn [29, 1933] gives an idea of the difficulty of separating the individual compounds which make up crude petroleum. In January 1927 the work of isolating and studying the component compounds of a mixed base Mid-Continent crude was started. Up to October 1933 an organization averaging 5 men had worked 6 years and isolated 30 compounds all below C_{11} . The compounds found in highest concentrations were *n*-heptane, *n*-octane, and *n*-nonane, and only 1% of each of these was present. Thus any reports of the isolation of appreciable quantities of simple compounds in the upper boiling ranges must be examined critically, and for all practical purposes, at least for some time, it can be considered that petroleum above the gasoline range is made up of an infinite number of compounds. There is then ample justification for considering the T B P curve of any crude or commercial fraction to be continuous, although it should be kept in mind that the absolute T B P must be represented by steps, the steps becoming smaller in the high boiling range. To avoid confusion, the definition of the T B P curve should be qualified by the statement that the distillation must be made with sufficiently sharp separation so that the results are additive for all fractions that may be considered. For example, if a crude, the T B P curve of which showed 25.6% boiling below 400° F., were separated without decomposition into various products which were in turn analysed in the T B P apparatus, the sum of the material boiling below 400° F. shown by the T B P curves of all the products should equal 25.6% within the limits of error for determination of the yields of the products. Obviously, if some product such as toluol is to be separated from the crude in a pure state, the assumption of a smooth curve is not consistent with this definition, for the smooth curve shows an infinitesimal amount of toluol in the crude and a finite amount is recovered. For practical purposes the T B P apparatus is satisfactory when the fractionation is sufficiently sharp, so that a sharper fractionation would

not give a curve showing lower boiling-points for the first 50% of the given sample

Simpler methods of distillation may be employed, such as the Engler, A S T M, or a short Hempel column may be used (see section on Laboratory Analyses by E H Leslie) All of these give boiling-point curves which lie above the T.B.P. curve in the lower range and below it in the upper range These curves are convenient for defining crudes and, especially, the lighter products Since most products which are to be used as motor and other fuels are specified by one of these simpler distillation analyses, the simpler curves give a sufficient definition of the product for commercial purposes There is, however, no simple relationship between these curves and the T.B.P. curve, for the differences depend on average temperatures, average slopes, and characteristics of the light ends of the curves The curves obtained by the simpler methods lack the one property of the T.B.P. curve that is of fundamental importance, namely, they are not additive Therefore the T.B.P. curve is the starting-point for any distillation problem

Vaporization Curves derived from the T.B.P. Curve

Given the T.B.P. curve, it may be possible to calculate by purely theoretical methods all the other boiling-point or vaporization relationships required Due to the complexity of the problem and uncertainty regarding the properties of the mixture of hydrocarbons making up petroleum, it is easier and safer to determine the required data by test in laboratory or plant

The type of data required will depend on the kind of distillation process used If it is the old-fashioned batch still without fractionation of vapours, a curve showing the temperature of the boiling liquid after any given per cent of material had been distilled off in an adiabatic flask would be useful If a batch still with fractionation is used, the same type of curve would be required, but the flask should have a fractionating column the hold-up in which was negligible compared to the liquid in the flask Since such types of distillation are only of historical interest today, these curves need not be considered

A method of distillation that is important in spite of the advances in pipe-still apparatus is the battery of shell stills with fractionating columns For problems involving such equipment it is necessary to know the boiling-point of any liquid residue from which a certain lighter portion has been removed and a portion of given boiling range is being continuously vaporized

Equilibrium Flash Curve

With the almost universal use of pipe stills, the equilibrium flash vaporization curve, called the Flash Curve, becomes of primary importance This curve is obtained by plotting the per cent vaporized against the temperature of vaporization, where the vaporization is carried out in such a manner that vapour and liquid portions are in equilibrium with each other at the given temperatures Several types of apparatus have been used to determine flash vaporization curves, and surprisingly divergent results have been obtained when heavy material is run under reduced pressures. The errors have been due to heat losses from the apparatus, to inaccurate measurement of temperature and pressure, and in the higher temperature ranges to cracking It is more difficult to get proper

measurements in this determination than would at first appear The vapour from an equilibrium flash of a broad fraction can be cooled nearly 100° F below the flash temperature before any large proportion is condensed Thus, only a small heat loss will cause a large error in reading the temperature of the vapour The temperature at the point of flash must be read and the material must be in equilibrium at this point For low-temperature work, the apparatus used by Leslie and Good [13, 1927] gives accurate results, but for determining the flash curve on a heavy residue, it is desirable to go to the maximum temperature that can be run without coking up the vaporizer and also to operate at a low pressure The apparatus described in the section by E H Leslie is convenient for this work The justification for this apparatus and proof of the accuracy of results obtained in it must be in the agreement of the results with those obtained in large-scale work under similar conditions, for it is difficult to check this apparatus on known mixtures at temperatures around 700° F and pressures below 30 mm The apparatus used to determine the flash curves of Figs 2 to 19 checked fairly well against units with capacities up to 7,500 bbl per day, in which the charge was vaporized without steam at pressures from 10 mm. to 30 mm abs Fairly close checks were also obtained against units in which steam was used in vaporizing the charge, although there was always a question as to the exact temperatures and pressures (partial of the hydrocarbon) to be taken as the equilibrium condition, and the results cannot yet be considered entirely satisfactory

Proomov and Beiswenger [23, 1929] worked out an empirical relationship between the T.B.P. and the flash curves which is reasonably accurate over certain ranges of crudes and fractions Nelson and Souders [17, 1931] suggested a refinement of this method, and Katz and Brown [11, 1933] give a revised plot based on their methods which is accurate over a wider range These various equilibrium curves are discussed by Brown and Souders in this section, p 1544 In this method it is assumed that the flash curve is a straight line, the equation of which is a function of the average slope between the 10% and 70% points of the T.B.P. or A S T M curve and the 50% point of these curves for the sample under consideration Obviously, the method is limited to materials with regular boiling-point curves and can apply only to the middle range where the curves are fairly straight These plots are useful in preliminary calculations and in checking the accuracy of laboratory determinations

The method developed by Murray [16, 1929] for calculating gas equilibria has been found useful for calculating equilibrium flash vaporization curves The procedure used for employing Murray's method is to divide the material under consideration into several arbitrary fractions, assuming molecular weights based on the mid boiling-points of each fraction For distillates this method gives almost a straight line coinciding closely with the line determined experimentally For reduced crudes Murray's method also gives results which coincide closely with the experimental data, if it is assumed that material boiling above a certain temperature is non-volatile under any conditions, but has a finite molecular weight A further discussion of this method is given later

Composition of Distillate and Residue

The characteristics of the products from any type of distillation must be known in order to obtain a complete

solution of a distillation problem. However, for the rough separations usually required it is necessary to know only approximately the type of boiling-point curves to be obtained. Leslie and Good [13, 1927] vaporized a light

The A.S.T.M. end point of the T.B.P. flask residue of the distillate from a single-flash distillation averages 165° F above the flash temperature and from a successive-flash distillation averages 150° F above the flash temperature.

The A.S.T.M. end point of the distillate from a differential vaporization averages 60° F above the final distillation temperature.

Leslie and Good pointed out that the single flash gives a greater yield of distillate and a greater exhaustion of residue for a given temperature than successive-flash or differential vaporization. The yield of distillate is certainly greater, but the single flash leaves more material with a boiling-point 150° F below the flash temperature in the residue than does the successive or differential flash. Since this light material amounts to only a few per cent, and since it is usually removed by stripping in either case, it is true that for practical purposes the single flash gives the best exhaustion of residue. Leslie and Good also stated that less heat is required to produce a given yield of distillate by the single than by the successive-flash method. This is only true when all flashes are carried out at the same pressure and no heat is recovered. It will be shown that for certain conditions a multiple-flash system, where heat is recovered and where the last flash is made at reduced pressure, may require much less net heat input from fuel than a single-flash system.

From the results tabulated above, it is seen that the difference in composition of corresponding distillates and residues produced by the different methods is not great. By single flash the yield of distillate is greater at a given temperature and more heavy material is found in the distillate. By successive flash more light material is found in the residue. In general, the method of distillation which is best suited for a particular practical case will depend on factors other than the sharpness of separation between the primary cuts into which the crude or other petroleum product may be divided.

Equilibrium Curves

Obyrdchakoff [18, 1932] suggested that equilibrium curves similar to those used for a mixture of two definite compounds be used for calculating the separation of petroleum mixtures according to the graphical method of McCabe and Thiele [14, 1925]. As explained by Brown and Souders, Part A, p. 1544

"These equilibrium curves are constructed by plotting along the ordinate the percentage of material boiling below any temperature in the vapour and along the abscissa the percentage of material boiling below the same temperature in the liquid in equilibrium with the vapour. This method assumes that for equilibrium purposes, any complex mixture may be considered as composed of two components, one representing all the material boiling below any chosen temperature and the other representing all the material boiling above this temperature in either liquid or vapour."

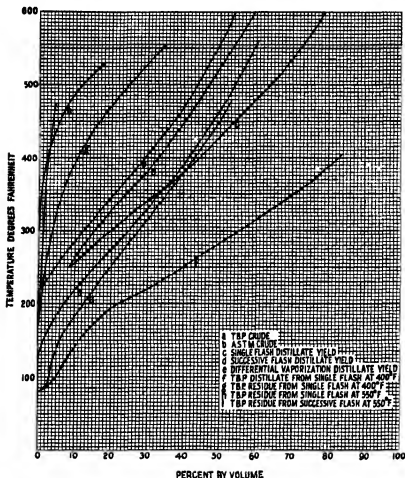

FIG. 1 Cabin Creek Crude Sp. gr. 0.7947 Equilibrium flash vaporization (Data from Leslie and Good)

Pennsylvania type crude by the methods of single-flash and successive-flash vaporization. The successive vaporizations were made by flashing the residues from a previous vaporization at 50° F higher temperature than that of the previous vaporization. The flash curves are given with other data on this crude in Fig. 1. The curve *e* gives the yield of distillate by differential vaporization. The data for this curve was obtained by distilling a sample of the crude in a 500-c.c. flask, the walls of which were heated with gas flames to prevent condensation.

The true boiling-points of the products obtained by single flash are given in Table I, and a comparison of the products obtained by single and successive flash and by differential vaporization is given in Table II. Data for the single and successive flashes were read from Figs. 4 and 7 of Leslie and Good's article [13, 1927]. Data on the differential vaporization are from unpublished laboratory records.

Of course, the batch or differential distillation is simply the successive-flash method in which the temperature interval between the steps is made infinitely small. The successive-flash method followed by Leslie and Good was entirely arbitrary, both as to temperature interval and temperature of first flash.

TABLE I

True Boiling-points of Products from Single Equilibrium Flash Vaporization of Cabin Creek Crude sp gr 0.7947

Temp of equal flash	Coordinates of T B P curves of distillates				
	100° F	200 F	300° F	400 F	500 F
250	*	*	*	%	%
300	25.9	62.8	91.6	98.7	100
350	10.7	40.7	83.3	96.5	100
400	5.7	29.5	68.0	91.2	99
450	5.0	22.0	56.3	82.9	95.7
450	4.3	18.2	47.0	71.5	89.0
500	2.5	15.0	40.0	67.0	82.3
550	2.4	13.0	37.7	56.3	75.4
600	2.5	11.6	32.7	51.2	70.0

Temp of equal flash	Coordinate of T B P curves of residues				
	100 F	200 F	300 F	400 F	500 F
250	0.3	*	*	*	*
300		6.2	20.5	36.5	51
350		2.7	13.5	28.5	44.5
400		1.4	7.0	18.4	35.5
450		0.7	4.0	10.3	27*
500		0.5	2.3	6.1	20*
450			1.7	4.0	13*
450			1.0		

* Calculated as difference between crude and distillate

TABLE II

Comparison of T B P Curves of Fractions produced from Cabin Creek Crude sp gr 0.7947 by Single and Successive Flash and from a similar Cabin Creek Crude sp gr 0.8003 at 50° F by Differential Vaporization

Flash	Coordinates of T B P curves of distillates				
	100 F	200 F	300 F	400 F	500 F
Single 400 F	*	*	*	*	*
Successive 400 F	5.2	22.0	56.3	82.9	95.7
Differential to 400 F	6.4	29.0	68.0	91.5	99.0
Single 500 F	2.5	15.0	40.0	62.0	82.3
Successive 500 F	4.5	21.3	54.0	80.5	94.0
Differential to 500 F	5.3	27.0	59.0	85.0	94.0

Flash	Coordinates of T B P curves of residues				
	100 F	200 F	300 F	400 F	500 F
Single 400 F	%	*	*	*	*
Successive 400 F		0.7	4.0	10.3	
Differential to 400 F		4.0	16.0	34.5	
Single, 500° F		6.2	20.0	39.0	
Successive 500° F		1.0	4.0	10.0	
Differential to 500° F		trace	5.5	19.0	
		1.0	8.0	24.0	

The proportions of distillate and residue boiling below the flash or flask temperatures for the three types of distillation are given in Table III below

TABLE III

	Distillate		Residue	
	%	%	%	%
Single flash	82.3	11.6		
Successive flash, final flash at 400° F	92.8	16.4		
" " " 500° F	94.6	19.0		
Differential vaporization	96.0	22.0		

Obyadchakoff stated that the equilibrium curve could be represented fairly closely by an equation of the form

$$y = 1 + (\alpha - 1)x^2 \quad (1)$$

in which y and x are concentrations of low boiling component in the vapour and liquid respectively. The constant α is related to the slope of the T B P curve. Katz and Brown [11 1933] state that equilibrium curves of this type 'may be used with satisfactory results in most cases particularly close-cut fractions', and they present plots showing various equilibrium curves for materials with T B P curves of various slopes. See Fig 13 in article by Brown and Souders p 1550. The equilibrium curves they give for use with T B P distillation data are similar in form to curves obtained by assigning different values to α in equation (1) although their curves were obtained by graphical interpolation and leveling of actual experimental data and they state 'These curves related more or less empirically to the T B P curve can be considered only as approximations which are usually more reliable for relatively close cut fractions than for materials of wide boiling range. As a first approximation the relation between α and the slope of the T B P curve may be taken from the following table

TABLE IV

Slope of T B P curve	α
1	2.0
2	4.0
2.5	5.9
3	9.1
4	16.0
6	70.0
8	45.0

The equilibrium curves for use with A S T M distillation data are not symmetrical. These equilibrium curves were said to be satisfactorily accurate for dealing with a California naphtha which had an initial boiling point of 180° F and a 90% b.p. of 437° F by T B P distillation. The equilibrium curves were given in weight or volume per cent.

Fig 2 shows the curve obtained by substituting a value of 35 for α in equation (1), which value corresponds to the slope of 6.6 for the Cabin Creek Crude. It will be noted that all the coordinates taken from the equilibrium flash data of Table I are within the limits of error on a single line and that this line follows the curve of Katz and Brown very closely up to about the point 85%, 15%. Above this point the experimental curve is well above the Katz and Brown curve. The Katz and Brown curves are to be used with weight or volume percentages. If mol percentages are used, the relation between the values of α and the slope of the T B P curve will be changed, but the equilibrium curve will still be unsymmetrical.

There is some question as to how far these equilibrium curves can be used in practical problems. Brown and Souders have obtained good results on a problem involving close-cut fractions (see Part A of their paper, p 1551). The method looks promising, especially for the solution of certain types of problems, but in using the petroleum equilibrium curve it must be kept in mind that the reflux ratio varies at different points in the column, because of the withdrawal of side streams and because of the large temperature differences in different sections of the column. Furthermore, the petroleum equilibrium curve depends on the

composition of the material present and will not be the same for all sections of the column. If the equilibrium curve is properly determined for each section of the column on the basis of the composition of the material in that part of the

or when the cut comprises the residue in which case there is an entirely different relationship between viscosity and flash and percentage of cut on crude. The whole problem of determining the maximum possible yield of a given cut with certain viscosity and flash specifications is complicated by the difficulty of obtaining accurate yield figures on the heavy fractions and by the question existing in many cases as to whether the viscosities and flashes may not be appreciably altered by cracking.

Within the limits of accuracy required at present it is found that the viscosity of the fractions of a crude plotted against the percentage distilled off up to the mid percentage point of the fraction forms a smooth curve and that this curve is the same whether the smallest possible fractions are taken or fractions amounting to 20% or more of the crude. The curve obtained by plotting the open cup flash point against the viscosity or against the mid percentage of the fraction is also the same over a considerable range of width of the fractions taken. The closed cup flash point curves which can be made more accurately than the open cup flashes would be constant for narrower widths of fractions. The curves for viscosity and flash points determined on 10% or narrower cuts seem to be accurate enough for all practical purposes provided the separation is made with a sufficiently good column. These curves can be used for estimating viscosities and flash points of the fractions for various break up of a crude when no individual fractions make up more than about 25% of the crude.

The viscosity or penetration and flash point of the residue plotted against the percentage distilled or the percentage residue give smooth curves useful when a residue lubricating stock or asphalt is to be run.

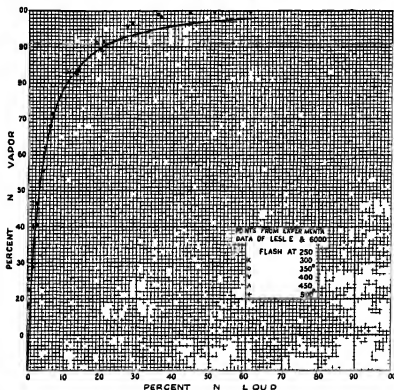

FIG. 2 Equal brium curves for Cab n Creek Crude. Comparison of curve based on data of Leslie and Good and curve constructed from the formula

$$y = 1 - (\alpha - 1)^x \quad \text{in which } \alpha = 35$$

(Data from Laboratory of E. B. Badger & Sons Co.)

column as can be done by means of the equilibrium constants described in the paper by Katz and Brown [11 1933] any ordinary problem can be handled in a satisfactory manner using the graphical method of McCabe and Thiele.

Viscosity and Penetration of Intermediate and Residue Fractions

It is found that within the limits of error of the analytical work the viscosity of a small fraction is not changed by adding to it equal small fractions cut from the crude directly above and below the given fraction. Furthermore the relationship of flash point to viscosity is not changed provided all fractions are reasonably sharply cut. The width of fraction that can be taken without throwing off the viscosity or the viscosity flash relationship is not accurately known. It varies according to the slope of the TBP curve and the location in the crude. Below are given data on fractions from a California Tar and Reduced Crude and a Mid Continent Crude showing that the flash-viscosity relationship is constant for cuts comprising from 2.5% to 31.7% on the tar, 3.3% to 23.3% on the reduced crude and 3.3% to 13.3% on the crude.

This relationship will not be constant when the upper end of the fraction cuts far into an asphaltic residue,

TABLE V
Unpublished Data from Laboratory of E. B. Badger & Sons Company

Sample	Cut	rd. v. c.	B range cut per cent F	SU vs.	Flash COC
Sample A	Cal form a Reduced Asphaltic Crude				
	Sp. gr. Sample 0.966				
Sample B	Cal form a Mid dewy Tar				
	Sp. gr. Sample 0.942				
Sample C	Mid Continent Crude				
	Sp. gr. Sample 0.932				
A	8	2.5	713-29	229 at 100 F	360
A	9	2.5	729-40	324	364
A	3-15 incl	31.7	582-851	271	365
Average from curve					
B	5	3.4	606-30	61.1	285
B	2-8 incl	23.3	509-680	57.8	295
B	12	3.3	731-49	305	370
B	9-15 incl	23.3	680-783	307	375
B	18	3.3	812-26	73.3 at 210° F	420
B	19	3.3	826-32	82.0	430
B	16-22 incl	23.3	783-865	79.2	425
Average from curve					
C	11	3.3	747.78	317 at 100 F	390
C	10-13 incl	13.3	720-850	325	390

The cut point temperatures are reduced to 760 mm by the O. G. Wilson chart.

crudes and for checking the accuracy of analyses Watson, Nelson, and Murphy [28, 1935] present interesting data on the characterization of fractions of crudes by various properties

Discrepancies in the relationship between flash-points and boiling-points in particular would indicate errors in the analyses For any sharply cut narrow fraction the open-cup flash-point must depend on the boiling-point If the flash-point obtained is abnormally high, there must be something wrong with the boiling-points, if abnormally low, the fractionation must be at fault, or the boiling-points may be wrong, or both The curve plotted in Fig. 20 is not given as the limit in accuracy There is reason to believe that the determination of the temperature of the vapours in a laboratory fractionation of petroleum is subject to what may be termed at present as normal errors of 10° F to 15° F Furthermore, it may be found that sharper fractionation than is now ordinarily obtained in the laboratory may give higher flash-points for a given boiling-point

O. G. Wilson's chart [29, 1928] for conversion of boiling-points to atmospheric pressure is also given in Fig. 24 This chart is accurate enough for pressures down to about 10 mm The chart given by Beale and Docksey [1, 1935] is probably more accurate than the Wilson chart for lower pressures This is given in Fig. 25 Although these curves and charts are not extremely accurate, they are close enough for all practical distillation problems

For more detailed data on these properties of petroleum see Section No. 20

DISTILLATION METHODS

The methods of distillation commonly used in petroleum refineries may be classified according to the type of apparatus employed or according to the material handled The apparatus falls into the following general classes

Shell stills, batch or continuous, heated by fire or steam

Pipe stills with columns operating under pressure or at substantially atmospheric pressure or under reduced pressure

Steam-heated column stills

Units for handling the various materials may be classified as follows

Topping units, single- or multiple-stage units for taking overhead lighter products from crude

Topping and reducing units, single- or multiple-stage units, including vacuum units, for running crude down to small percentages of residue

Re-run units for lubricating oil, including solution recovery units

Re-run units for pressure distillate

Cracking units These are described in the section on cracking

Crude and gasoline stabilizer units The gasoline stabilizer units are described in the article by Brown and Souder

Any detailed description of all the variations of heating and fractionating apparatus in use, or the different combinations which have been or may be used, would take up too much space Only the arrangements in general use need be considered, and no attempt will be made in this section to describe in detail the construction of the pumps, heaters, columns, &c., which make up the units

The main consideration in any distillation unit is of course the total cost of making a required separation Into this total cost will enter the following items.

Amortization, obsolescence, and interest on first cost of unit

Charge for ground on which unit stands

Operating labour

Repair cost, labour, and material

Utilities—fuel, water, steam, air, electricity

Losses

Special overhead charges determined by type of unit

Since the cost is an overall figure based on throughput over an indefinite period, the idle time of the unit must be considered and this is affected in an indeterminate way by fire and explosion hazards Anything in the design that increases such hazards must be counted against the unit

The accurate evaluation of all these factors is impossible, the answer to any problems of design must be the result of long experience and is often largely a question of judgement

For example, a unit might be designed to operate with half the fuel consumption of units now in use, but the saving in fuel might entail frequent shut-downs for cleaning or repairs There might be shown a net gain for the saving in fuel over the cost of the shut-downs and repairs, but the added risk of accidents and fires on account of the more frequent shut-downs might well offset this apparent net gain It is for such reasons that the advance in petroleum distillation practice has been slow and has, to some extent, been determined by custom or fashion rather than definite theoretical considerations To keep down the losses, methods of heating and of separation must be such that the material is not subjected to excessive temperatures This consideration rules out many methods that might seem to have great theoretical advantages

There is a further complication in that the 'required separation' is not definite The commercial specifications of the products may allow or require considerable overlapping of the cuts For example, the gasoline cut may be specified with an ASTM end point of 400° F, but kerosene of a certain viscosity may be required If the maximum yield of gasoline is taken, there may be no kerosene By putting some of the heavy ends of the gasoline into a kerosene cut with material boiling above 400° F which would otherwise go into gas oil, a greater overall return on the crude may be obtained Even if the actual value of the kerosene is less than the value of the gasoline and gas oil which goes into it, the gasoline may be so improved in anti-knock or volatility characteristics by putting some of the heavy ends into the kerosene, rather than in re-forming these heavy ends, that there would be an overall advantage in making an overlap between the gasoline and kerosene Theoretically there might be a further advantage in making a sharp separation between the gasoline and kerosene, substantially excluding material boiling below, say, 375° F from the kerosene and above 380° F from the gasoline Sharper separations cost more for equipment and fuel, and there will always be a limit to the degree of separation which it is worth while making. A further discussion of this point is given in the description of the two-stage unit on p. 1598.

General Considerations in Design of Crude Topping Units

Shell-still Units.

The simplest distillation unit consists of a shell still and a condenser If charged continuously, it would divide the charge into one overhead and one residue cut; or if run batch, it could produce any number of overlapping

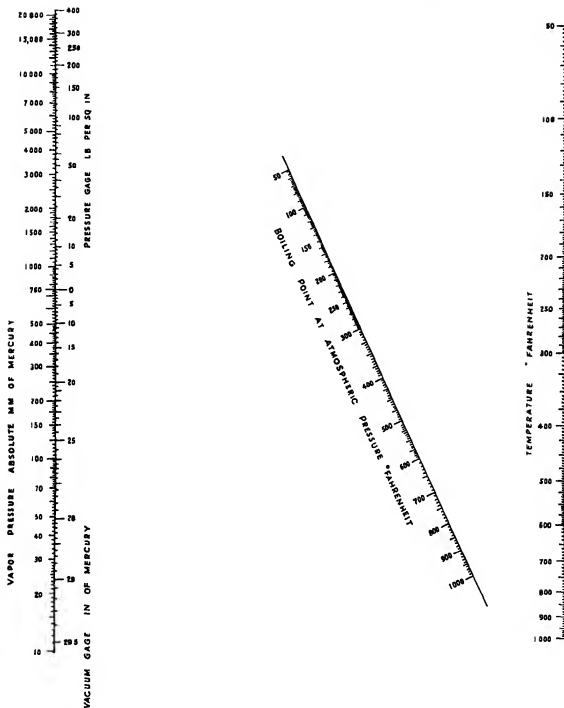

**VAPOR PRESSURE OF NORMAL
PARAFFINE HYDROCARBONS**

Nomographic chart of the vapor pressure of normal paraffine hydrocarbons from the equation

$$\log \frac{p}{p_0} = \frac{0.0002091(t_0 - t)}{5.318 - t + 0.0001491 t^2}$$

where p = absolute vapor pressure mm Mercury
 p_0 = normal atmospheric pressure = 760 mm
 t = temperature ° F
 t_0 = boiling point of normal atmospheric pressure ° F

FIG 24 O G Wilson boiling-point conversion chart

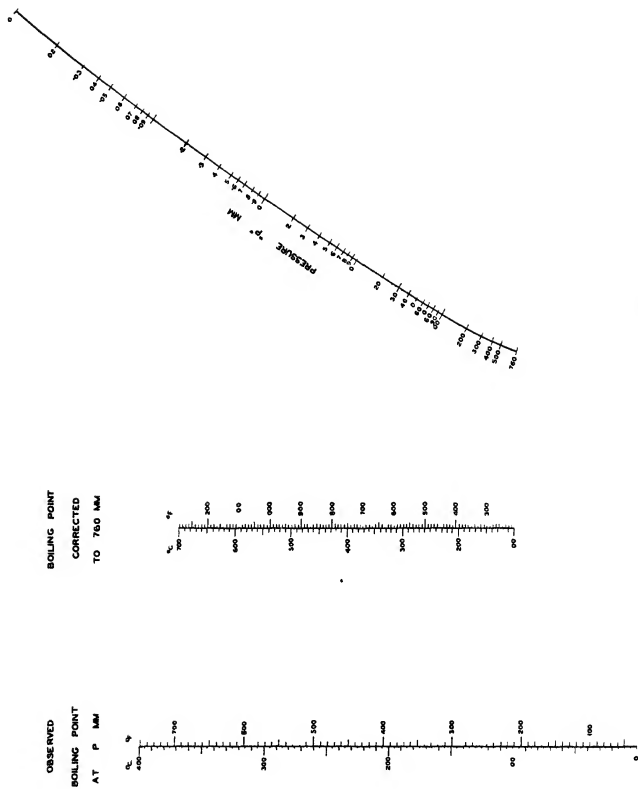

FIG. 25 Beale and Dockery boiling point conversion chart

distillate cuts and a residue. The early units were of this latter type. Partly because there was no great advantage in making sharp separations of the distillates and partly because of a non-technical attitude in the industry, efficient fractionating devices for the vapours were not used until comparatively recently.

It is evident from the data given on the composition of vapours produced by differential and successive vaporization that there would be little theoretical difference between a continuous unit which employed shell stills and one which employed pipe stills for heating the charge. There are, however, several practical disadvantages in the shell still which have led to its replacement, in many cases, by the pipe still. Considered as a heating unit, the shell still

TABLE VI
Operating Cost for Combination Shell-still and Pipe-still Unit of Figs 26 and 39

Average daily throughput	30,000 bbl
Type crude	Mid-Cont
% bottoms	11.8 cents/bbl
Operating wages	0.53 "
Fuel at 75 c per 42-gal bbl	1.42 "
Steam	1.49 "
Repairs	0.54 "
Total direct expense	3.98 "
General plant overhead	1.23 "
General overhead depreciation and taxes	1.54 "
Total distillation cost excl pumping	6.75 cents/bbl

SHELL STILLS WITH TOWERS

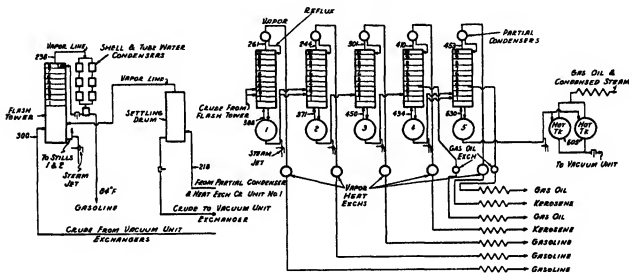

FIG 26

costs more and takes up more room than a pipe still of similar capacity. A shell still 15×42 ft, with internal tubes, can absorb about 15 to 17 million B Th U per hour at an efficiency of 70% to 74%. A pipe still of the same capacity would take up a space about 20×24 ft, and could easily be designed to operate at an efficiency of 75% (although it is usually considered better practice with present-day fuel costs to design for 65% to 70% efficiency).

It is not practical to build shell stills larger than 15×45 ft, and if greater capacities than about 15 million B Th U per hour are required, more than one still must be put in.

Fig 26 shows a typical continuous shell-still battery with a heat input to the oil of 75 to 80 million B Th U in five stills (For operating data see end of article). It will be noted in comparing the fuel consumption of this unit with the various pipe-still units shown in the figures following that it is just as low as the most efficient pipe-still units. Furthermore, the cuts are as sharp as those obtained from modern pipe-still units. Comparison of the operating costs of the large combination shell-still unit and vacuum unit of Figs 26 and 39 in Table VI with those of the pipe-still units given in Table VII shows no very great difference. The units of Tables VI and VII were operated by different companies. The cost figures given are therefore not strictly comparable.

since different systems of accounting were used for the different units. The main mechanical disadvantages of the shell still are its greater first cost, greater space requirements, and greater hold-up of oil for a given heat input. A further disadvantage is that the film of oil on the bottom heating surface tends to become overheated to such an extent that it deposits coke on the still bottom, or in the case of charging stocks valuable for their lubricating oil, it will decompose to lighter and less valuable products. This last effect may be an advantage in the case of certain heavy residues from which increased yields of lube stocks can be obtained by prolonged heating in shell stills.

Shell stills are usually fitted with perforated pipes near the heated bottom plates. Steam blown through these pipes agitates the oil and allows a considerably higher heat input per sq ft of heating surface than would be possible without the steam. C W Stratford circulated oil with centrifugal pumps, discharging it through many jets to impinge against the heating surface. He obtained very high transfer rates and greatly increased the capacity of the stills by this method. Later he substituted a large internally fired flue for the bottom shell of the still as a heating surface. This flue was easier to keep clean. In his final design Stratford uses a firing tube with dimensions in the proportion of 4 ft in diameter and 12 ft long. This tube is corrugated and is surrounded by a steel cylinder into

TABLE VII
Operating Costs of Large Pipe-still Units

	A		B	
	27,100 bbl Mid-Cont 7 to 10	8,450 bbl Coastal 18 to 20		
Average daily throughput	27,100 bbl	8,450 bbl		
Type crude	Mid-Cont	Coastal		
% bottoms	7 to 10	18 to 20		
Salary, supplies, and clerical	0 14 cents/bbl	0 24 cents/bbl		
Operating wages	0 33 "	0 99 "		
Inspection and cleaning	0 07 "	0 12 "		
Laboratory	0 04 "	0 09 "		
Miscellaneous	0 03 "	0 06 "		
Vacations	0-03 "	0 04 "		
Fuel	1 76*	2 39*		
Steam	0 78†	1 66†		
Chemicals		0 32 "		
Condenser water	0 39‡	0 46‡		
Compressed air	0 01 "	0 02 "		
Oil		0 01 "		
Repairs labour	0 11 "	0 50 "		
" material	0 32 "	0 32 "		
" expense	0 02 "	0 02 "		
Total direct expense	4 03 "	7 24 "		
Indirect expense	0 26 "	0 68 "		
Overhead depreciation and taxes	1 49 "	2 42 "		
Total distillation cost	5 78 "	10 34 "		
Yard pumping	0 77 "	0 52 "		
Total incl pumping	6 55 cents/bbl	10 86 cents/bbl		
* Fuel at 75 c per 42-gal bbl		† Steam at 33 33 c per M		
‡ Water at 4 c per M				

which is fixed the oil-circulation nozzles. A third cylinder or outer shell surrounds the second cylinder. This third cylinder has a circular manifold for distributing the oil to the circulation nozzles. The oil flow from the jets at a velocity of 25 to 30 metres per sec, maintaining a high, short film velocity on the surface of the firing tube. A full description of this heater is given by Dobrescu [6, 1933]. The data tabulated below is taken from an acceptance test on the unit described by Dobrescu.

TABLE VIII
Operating Data on Stratford Still
(Furnished by C W Stratford)

Net projected radiant surface approx	120 sq ft
Temp flue gas from radiant section	670° C
" " " air preheater	285° C
" preheated air to burner	260° C
% CO ₂ in flue gases	12%
Net overall thermal efficiency	85%
Recovery of heat in radiant section	67%
" " " convection	8%
" " " air heaters	10%
Stack loss and radiation	15%
Total heat in combustion gases	100%
Total heat input to oil, normal rating	7,200,000 B Th U
Heat fired per sq ft net projected radiant surface	71,000 "

The normal rating was for a throughput of 2,400 bbl of crude per day per firing tube. A rate of 2,750 bbl per day was attained, at which higher rate the load on the heater was 8,250,000 B Th U per hour.

The Stratford arrangement of the radiant surface is compact and comparatively inexpensive. The convection section and air preheater are, of course, the equivalent of those on any other unit and no saving is made nor could any greater efficiency be obtained, except possibly through better engineering design in this part of the equipment.

One reason why high rates can be obtained in the

Stratford heater is that only flashed crude is put through the radiant section. The greater cause of dirty tubes in the usual pipe still is salt which comes out at the point where the moisture in the crude flashes. If the moisture is removed by a primary flash, as in the units of Figs 34, 35, and 38, much higher rates can be run in the conventional pipe still without burning the tubes. Another reason for the high rates obtained in the Stratford heater is that the air to the burners is preheated and a type of fuel-oil burner is used that will give an ideal flame. Experience with a vertical cylindrical heater in which the tubes were arranged on the circumference of a 12-ft diameter circle indicated that ordinary refinery fuel and ordinary refinery labour might lead to trouble when the flame was allowed to come as close to the heating surface as it does in the Stratford radiant heater. It may be that the velocity of circulation is high enough so that the surface cannot be burned, especially if the flow is arranged so that there is no vaporization in the heating zone. This can only be demonstrated by experience.

M P Youker invented an arrangement of shell stills with a single column that gave good results. This invention, covered by U S P 1,735,558, consists in running the crude in series through several shell stills and leading the vapour from the stills into a single column, the lightest vapour from the first still entering the column near the top and the heavier vapour streams being introduced at progressively lower points in the column. The gasoline or lightest cut is taken overhead from the column, and kerosene or other intermediate cuts are taken from suitable points at the side of the column. A battery of four shell stills at the Paragon Refinery, Toledo, was hooked up according to this method, by E H Leslie. While the products obtained were acceptable, the results were not good enough to make the shell stills show up favourably in comparison with pipe stills, and no further installations were made.

Youker also covered, in U S P 1,735,558, a similar system of distillation in which the series of shell stills was replaced by a column. Crude was introduced at the top of this primary column and heat supplied at the base. Vapour from the top and from intermediate points was introduced at suitable points in the second column, and finished products were taken from the top, side, and bottom of this second column. This system did not come into general use, for the reason that the temperature at the base of the primary column had to be so high that the column coked up.

It is evident that a great many combinations are possible in hooking up several shell stills to one or more fractionating columns. The stills might be run in parallel and the vapour and liquid from each still discharged together through one line or separately through two lines into a fractionating column. Or they may be run in series and the residue from one still be stripped in a column with steam or by vapour from the next succeeding still. The reflux from each column may be introduced into the next succeeding column instead of running back into the still.

Perdew [19, 1929] gave 10 methods of modernizing old shell-still batteries. He states that the 'shell still or shell still-pipe still hookup can be made just as efficient in respect to fuel consumption and just as automatic in respect to operation as can any tube still-bubble tower hookup', and further 'It should be noted that a new shell still battery or shell still-pipe still hookup in which all these heat exchangers and instruments are employed will

cost more than a new tube still-bubble tower hookup which will do the same work.

It is not probable that the shell still will come into general use again—certainly not until conditions in the petroleum refining industry have changed a great deal.

Pipe-still Units.

Heaters. The rapid introduction of pipe-still units started about 1926, although pipe stills had been used long before this time. The earlier pipe stills, like the earlier shell stills, were comparatively inefficient, the surfaces were not arranged to give the maximum heat input without overheating the charge, and the poor mechanical construction led to shut-downs and high upkeep costs. The problems involved were simple, and as soon as engineering principles were applied to the design a type of still was developed that has since been changed only in minor details of construction and arrangement. The important factors which had been missed in the early design were first, to keep the velocity of oil in the heated tubes high enough so that heat passed into the body of the oil without overheating the film of oil against the tube wall and, second, to arrange the tubes so that the heat went into as much of the surface as possible at a reasonably high rate. The maximum practical rate for normal oil velocities (3–10 ft per sec) was found to be about 8,000 B Th U per sq ft of total heated surface per hour. With clean charging stocks this could be greatly exceeded, and with some heavy stocks it could be reached only if the oil velocities were high. At this rate of heat input it was found that 40–50% of the heat in the fuel could be put into tubes arranged in the fire-box to absorb largely radiant heat, and the remainder would be absorbed in a convection or economizer section, the size of which, and amount of heat absorbed, depended on the thermal efficiency desired. Various arrangements, such as the Stratford heater described above, have been proposed to allow for higher rates of heat input into the heating surfaces. It is possible to reach rates of 100,000 B Th U per sq ft if the velocity of oil across the surface is high enough. The cost of operating with the high oil velocity required may be greater than the advantage obtained from reduction in radiant heating surface, and there has been little development along this line. The main advance in design has been in arrangement of surfaces to give the most even rate of heating in the most compact setting. The de Florez vertical heater gives very even rates of heating, but at an increased cost, so that it is better adapted for cracking work, where a premium can be paid for even heating, than for topping units.

The cost of a pipe-still heater will depend on the allowable firing rate and the heat recovery required. Below are tabulated approximate costs of heaters erected, based on a rate of 60,000 B Th U fired per sq ft projected radiant heat absorbing surface and 67% heat recovery.

	\$
10,000,000 B Th U input to oil cost about	18,000
20,000,000 " " " " "	30,000
50,000,000 " " " " "	53,000

Steam boilers with the same heat inputs would cost roughly about \$6,000, \$11,000, and \$26,000, based on a rating of 200%.

The shell still used in the battery of Fig. 26, which has a capacity of about 16 million B Th U per hour, would cost approximately \$36,000 (without stack).

It is possible that a more economical type of heater than the pipe still will be developed. Sodium liquid or vapour

has been suggested, and mercury vapour heaters are in use. A mixture of salts with low melting-point has also been suggested for transferring heat from the furnace to the oil. Direct combustion of air in the oil is a possibility and is, in fact, successfully used in the Clark cracking process, in which fuel is burned under pressure and the products of combustion mixed directly with gas-oil vapours [8, 1935]. This method has certain disadvantages, such as the formation of oxygen compounds and the large amount of gases from which the lightest product must be recovered.

Various radical departures from accepted design of heaters have been made at times, with the idea that the method of heating had some effect on the separation obtained. For example, a large amount of money was spent on a device to put the heat into a thin film of oil. Another heater used for vacuum distillation was designed to remove vapour as quickly as possible from the charge as it flowed through the heater tubes. Such devices never have had, and certainly never will have, any merit except in so far as they may conform to the specifications for an efficient petroleum heater, the principles of which are that it shall burn the fuel efficiently and that the heat shall be put into the oil without overheating on the heating surface.

Fractionating Columns. In order to make use of the possibility of putting all the heat into the charge in a single heater, it was necessary to use fractionating equipment that would separate the combined vapours into the desired products. It was found, in some cases, that a single bubble-cap column gave sufficiently sharp cuts. The lightest product, gasoline, would be taken from the top, kerosene, gas oil, and other intermediate products from the side, and residue from the base. Of course, with a single column, each side product must come off with somewhat more light material than is present in a mixture in equilibrium with the vapours at the point of withdrawal, and the bottoms will be in equilibrium with the total vapours at the vaporizer. In order to remove some of the lighter ends from these side products and the bottoms, they are often put through stripping sections and stripped with open steam. The permissible overlap for the commercial main column is usually so great that a relatively inefficient main column and small steam strippers give adequate separations.

Many kinds of fractionating columns have been used in petroleum refining, such as various types of baffle towers, packed towers, columns with sieve plates, and columns with bubble plates. The latter type have proved most satisfactory for many reasons, principal of which are their greater efficiency per dollar of cost and greater flexibility. The best baffle towers have a high HETP (Height of Equivalent Theoretical Plate) [21, 1922], as have packed towers, unless the packing is very small. It is difficult to get proper distribution of reflux in large packed towers with small packing. Sieve-plate columns have many theoretical advantages, but they lack the necessary flexibility, and the perforations in the plates are too likely to become enlarged by corrosion, or plugged up by deposits of coke, resins, or dirt, for them to be of practical value in ordinary petroleum work.

The cost of bubble-plate columns is relatively small, and they take up little room in a refinery, but for sharp separations they must be quite high, if sufficient space is left between the plates to make cleaning safe and easy. Smaller fractionating devices, such as the Podbielniak centrifugal fractionator, may be developed to do the same work, but the chances are they would not compare with the bubble-plate column for petroleum work, where it is

essential that there be no small openings to plug up or very large surfaces that may have to be cleaned.

Although the bubble-plate column is old in the art of distillation, it is so difficult to check its performance by accurate quantitative efficiency tests, particularly with mixtures like petroleum, that there is a considerable variation in design of the caps, plates, down-pipes, &c. Many loose statements regarding the relative merits of different designs go unchecked, and some columns are built that show surprisingly low efficiencies, when it is possible to make a quantitative check on them.

It has been commonly assumed that a well-designed column will give a plate efficiency of 50% to 60% when separating materials in the range of gasoline and kerosene, because the same type of column shows this efficiency on mixtures of benzol and toluol, which are similar to the lighter petroleum products. Brown and Souders report an efficiency of 108% for a stabilizer column and efficiencies of 72.5% to 97% for an experimental column running naphtha (see p 1609). It appears that the efficiency obtained depends on the material being separated and also on the method of calculation used. Particularly in dealing with the higher boiling, more complex mixtures, there would seem to be little use for theoretical calculations of plate efficiencies, except in comparing operating units, and until much sharper cuts are demanded, it would appear best to use the same plate design for petroleum work that has been proved by quantitative tests and long experience to give the highest efficiency in work with acids, alcohols, coal-tar products, &c.

Heat Exchangers and Recovery of Heat. The introduction of continuous distillation processes made possible and economically essential the extensive use of heat-recovery apparatus. When heat exchangers were first introduced there was a tendency to try to recover the greatest possible amount of heat. Improper design of the heat-exchange equipment, and corrosion troubles, led to a higher cost for keeping the exchangers in operation than the recovered heat was worth. Until fuel becomes more valuable, the best balance will be obtained by putting exchangers only where they will give the least trouble, and by not trying to recover all the heat that theoretically could be recovered. As fuel becomes more valuable it will pay to install more complicated systems for heat recovery, but, at the same time, more attention will be paid to using cheaper fuels, such as powdered coke or coal. On topping units the principal corrosion is in those parts where water can condense, thus vapour heat exchangers were found to be responsible for the most shut-downs for repairs and are sometimes eliminated in the later units. Nearly as much heat can be recovered economically with the same amount of surface from those products which are taken from the column in liquid form only as can be recovered if vapour heat exchange also is used. This applies particularly to the simple single-flash unit making a relatively light gasoline overhead.

The arrangement of the heat exchangers on any unit is entirely a matter of economic judgement. The added complication of the extra lines and valves and the cost of these lines and valves is a more serious item than the cost of the exchanger, when the cut from which heat is to be recovered is of a certain minimum size. The total cost of lines, valves, and exchangers may overbalance the value of the fuel saved where the cut is less than, say, 200 bbl per day. Even on this cut the exchanger will take some time to pay out, for, assume that its temperature is reduced

250° F in the exchanger, 90% of the heat being recovered in the charge, and assume the mean temperature difference to be 100° F and the transfer rate 30, the total heat transferred amounts to 330,000 B Th U per hour, worth 5 6 cents in fuel at 70 cents per bbl, with a heating value of 145,000 B Th U per gal burned with a recovery of 67% of the total heat. The exchanger with 125 sq ft would cost about \$1,093 installed and insulated, and the valves and lines to by-pass the exchanger would cost \$267, making the total cost of the exchanger \$1,360. The extra cost of the pipe heater to put in 360,000 B Th U would be approximately \$500, making the net cost of the exchanger \$860, an amount that would be paid off in 1,535 hr, or 2 years of 320 days. This may seem a short time to require an exchanger to pay out, but the chances of leaks, corrosion, &c., and the time required for cleaning, may make even a shorter time advisable.

The amount of exchanger surface to be used and the arrangement of this surface give more chance for variation than any other points in the design of a unit and, until sharper separations are required, will often be the determining factor in the design. In nearly all distillation problems outside the petroleum field it is of advantage to run as high a reflux ratio as possible, under the conditions, at every point in the column. In separating petroleum products it may often be found that more heat is required to vaporize the products than is necessary to make the desired separation of the lightest cuts. Thus, it may be of advantage to recover heat from an intermediate point in the fractionating system.

This can be done by passing some or all of the vapours from an intermediate plate through an exchanger and back into the column. Alternatively the reflux may be passed through exchangers at one or more points down the column. Where the desired amount of heat cannot be obtained from the net reflux passing down the column, it may be convenient to recirculate liquid back over a plate or in a spray.

One case in which heat is taken from the reflux is illustrated in Fig 27 (For operating data see end of article.) If no heat were removed from the column in this single-flash system, the reflux of overflow to vapours ratio (R) (excluding steam, if present) would be 0.82 at the top of the column and 0.73 at a point half-way between the kerosene and gas-oil draw-off. By taking out 8,050 B Th U per bbl of charge, used in this case to reboil light products, R is reduced to 0.8 at the top and 0.66 at the intermediate point of the column, values which are ample to give the required separations.

Fig 28 shows a unit in which vapours from an intermediate point in the column are put through a heat exchanger removing 27,600 B Th U per bbl charge and reducing R at the top of the column from 0.965 to 0.9.

A system of circulating reflux for taking heat from the top or from an intermediate point in the column was developed in 1918 on the old Trumble topping units. This system is convenient when the vapours are corrosive. If the circulated liquid is taken out at a temperature above the condensation point of water, it will not attack the condensing or cooling surfaces. If, further, the cooled liquid is sprayed back over chemical ware tile or other corrosion-resisting material in the column, the troubles from corrosion in topping units are to a great extent eliminated.

Peterkin [20, 1928] has given a description of an ideal distillation plant that still stands to-day for certain opera-

tions with a single-flash unit He contemplates a pipe-still outlet temperature of 800° F with 80% of the charge vaporized and a temperature of 283° F for the vapours from the top of the tower, and he shows the heat that may

the vapours in the tower as well as from the products, preheating the charge to 530° F Although Peterkin did not consider the second arrangement practical, there is no reason why sufficient heat could not be obtained from the

SINGLE FLASH UNIT WITH GASOLINE RERUN TOWER & HEAT TAKEN FROM MAIN TOWER

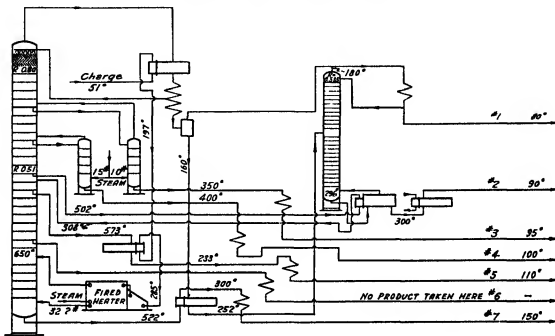

FIG 27

SINGLE FLASH UNIT WITH INTERMEDIATE HEAT EXCHANGERS

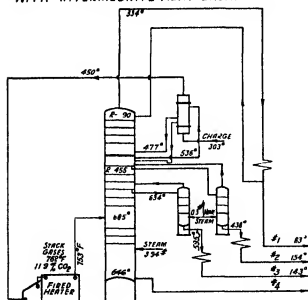

FIG 28

be recovered from the vapour and liquid products alone, on the assumption that the end temperature difference in all exchangers is 20°, a figure which he admits is optimistic With this arrangement there is required 106,000 B Th U per bbl. heat input to the oil and steam in the heater He also shows an arrangement in which heat is taken from

tower and products to preheat the crude to 550° F, if the cost of equipment to recover this amount of heat were justified In 1928 Peterkin assumed that equipment was justified if it would pay out in 5 years To-day, equipment which is not essential to the operation must pay out in much less time—in fact, many refiners demand that it pay out in less than 1 year

In the unit described by Brandt [2, 1928] of Cities Service plant at Philadelphia, a large proportion of the heat in the column is recovered by heat interchange with the crude which passes through exchanger coils in the column It is understood that in spite of the apparently great economy of this type of unit it was not practical because of difficulties from corrosion and fouling of the exchanger surfaces, at least such units have not come into general use

S M Jorgensen has proposed an arrangement by which even more heat may be recovered He would preheat the crude as far as possible by heat from the products and then introduce it into preheater sections in the column These preheater sections are constructed of a large number of vertical tubes, the lower ends of which are rolled into a plate with the upper ends open The crude flows around these tubes and the vapours rise through them Vapours liberated from the crude mix with the vapours rising through the tubes By properly choosing the location of the tubular sections, Jorgensen states that a comparatively large amount of heat can be recovered Apart from the practical difficulties involved, such as the difficulty of cleaning between the tubes, and in boiling crude into the tubes, there is the disadvantage that the sharpness of separation between the cuts must be considerably reduced,

not only on account of the heat abstracted at intermediate points in the column, but also because the vapours from the crude would have a wide boiling range. A further disadvantage arises from the fact that in all cases where a substantial amount of heat can be recovered from the column without affecting the separation too much, the vaporizer temperature is high—often as high as can be run without breaking down the oil. If much of the light ends are taken off before the charge is heated and vaporized, the required vaporization cannot be obtained at practical temperatures. It is possible to go to comparatively low bottoms by the single-flash system because of the carrying effect of the light vapours. When the light ends are removed, the boiling-point of the residue is greatly increased. Jorgensen proposes to reduce this boiling-point by circulating a considerable amount of heavy reflux from the base of the column through the heater. There is probably a range in single-flash distillation systems between the case where too little distillate is taken to permit of heat being recovered from the column and the case where a high vaporizer temperature is run and a low percentage of bottoms made in which the Jorgensen system would be economical. It certainly represents the theoretical limit in one direction of heat recovery, as the Youker system (see p 1590) may be said to represent the theoretical limit of heat utilization for separation. Both systems are limited in their practical advantages by the fact that petroleum cannot be heated, even in pipe stills, beyond a certain point without cracking.

Condensers and Coolers Tubular condensers and coolers can be made that are entirely satisfactory from the mechanical standpoint, and their cost is considerably less than that of cast-iron coils for the same duty.

The cast-iron coil is still used, both on account of the fact that it can be more surely protected from corrosion and, especially, because the large amount of water in the coil box eliminates the danger from fire in case of a failure of the water supply. If a large unit with tubular condensers is not shut down within a few minutes after the cooling water fails, it will blow vapours from every vent.

When reasonably clean water is available, a direct-contact type of condenser may have advantages over the tubular or coil type, especially in large-sized units.

Instruments, Pumps, &c. The present-day continuous pipe-still unit depends as much on the development of suitable control instruments as on the steel return bends and fittings that make the large heaters a possibility. But just as in the case of heat exchangers, the application of automatic control was pushed too far, and on some of the earlier units the instruments gave as much trouble as all the rest of the apparatus together. It has been found that the least control that can possibly be used gives the best results and that no control that is indispensable, i.e. that cannot be replaced by hand operation for short periods, should be used. By fixing certain basic points the control is greatly simplified, and complicated units will run almost by themselves. It is desirable that steam pressure be constant with a variation of less than 1%, and it is entirely practicable to make it so, electricity should, of course, be of constant voltage, and water pressure reasonably constant. With constant steam pressure, large pumps will run at a very even rate and can be operated by hand control fairly well, but it is so important to get a constant charging rate that a recording flow controller is essential.

Given a constant charge rate and constant firing which

can be obtained almost as well by control of the amount of fuel as by temperature, all other points on a unit except the overhead streams can be taken care of by controlling the volume of liquid flowing. Not only is there likely to be more variation in the percentage of lightest cut in the charge, but the use of partial condensers complicates the control of overhead cuts by volume, and it is found more practicable to control by temperature. The instrument companies have developed intricate thermostatic controllers for reflux which work well if treated properly. The care of these thermostats and flow controllers requires a specialized skill that was not formerly available in refineries. Direct volume control checked by recorded temperatures for all side streams greatly simplifies the operation of a unit making a large number of cuts.

In general, the large present-day units have been developed both because of requirements within the industry and as a result of manufacturers of steel fittings, pumps, instruments, &c., making available improved equipment. The improvements were made partly as a result of the demand from the petroleum industry, particularly the cracking section, and partly because of demands made by other industries. Quoting Howard and Loomis [10, 1928] 'There are many reasons for this limited use of vacuum distillation. Crude petroleum has been relatively cheap and there has been little incentive to make the maximum yield of lubricants from it. Vacuum equipment is more expensive in proportion to its size than that for atmospheric operation and requires better workmanship.

Only within recent years have manufacturers been able to furnish pumps, steam jets, etc. which will satisfactorily and cheaply maintain high vacua on large commercial equipment.' The same situation existed in regard to all petroleum products, the raw material was cheap, labour unskilled, and apparatus for making large units run economically had not been developed.

Examples of Typical Topping Units

Shell-still Batteries.

The single-batch shell still is practically obsolete and need not be considered here. The shell still can, of course, be used as a heating element in any distillation units where the distillation temperature does not rule it out. Naturally, the cheaper pipe still will be used except in small units, and it is not worth while considering cases in which shell stills would replace pipe stills as the heating element. A conventional shell-still battery, mentioned on p 1589, is shown in Fig 26. The arrangement shown may be improved to give somewhat better separations between the cuts by running the residue from one still into a stripping column through which the vapours from the succeeding column pass on the way to the rectifying column of that still. The two columns would usually be made in one shell. A small saving in fuel and proportional increase in capacity can be made by taking the reflux from the base of each rectifying column and introducing it at an intermediate point in the succeeding rectifying column. The effect on sharpness of cut by thus transferring the reflux is nearly negligible with efficient columns, but the saving in fuel may be considerable. At least, the control of the operation is easier, for if the reflux is run back to the still, the boiling-point of the still charge increases very little as more vapour is taken off. The operator can increase the heat input up to the limit of the still and the reflux ratio up to the limit of the condensing equipment without any appreciable effect except to

a given A.S.T.M end-point than is shown to be present in the crude by T.B.P. up to the temperature of the A.S.T.M end-point. As Good and Connell [9, 1933] showed, this

second column, part of the reflux for which is furnished by two preliminary cuts drawn from intermediate points in the upper part of the first column. (For operating data see end

SIMPLE SINGLE FLASH UNIT WITH SIDE STRIPPERS

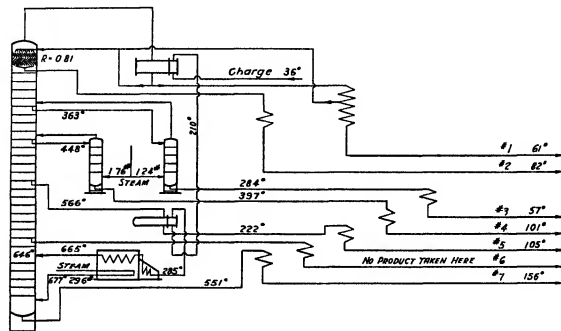

FIG 31

SINGLE FLASH UNIT WITH SECONDARY TOWER & SIDE STRIPPERS

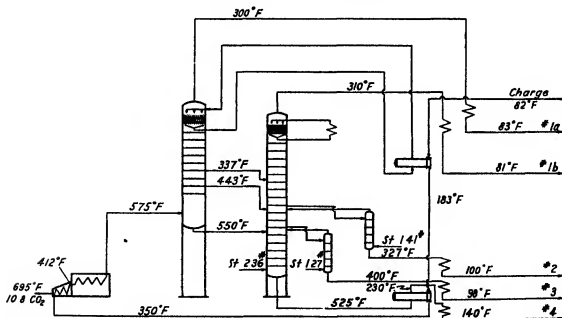

FIG 32

difference is due to a variable error in the determination of end boiling-point by the A.S.T.M. method.

Figs. 32 and 33 show a single-flash two-tower unit in which the flash is made without steam in one column, the residue then being stripped with steam in a second column, the stripped vapours passing through the upper part of this

of article.) A comparison of the data in Figs. 30 and 32 shows that the two-tower system is no improvement over the simpler single-flash system. (The greater fuel consumption shown for the two-tower unit is on account of less heat exchanger surface in the particular unit from which the data for Fig. 32 was taken and is not a necessary defect of the two-tower

system.) Fig 34 shows a two-tower system similar to that of Fig. 32, except that the preheated charge is flashed before going to the heater. (For operating data see end of article)

Two-flash Two-tower Topping Units.

Fig 35 shows the arrangement of a unit in which the crude, preheated by heat exchange, is flashed in a primary

SINGLE FLASH UNIT WITH SECONDARY TOWER & SIDE STRIPPERS

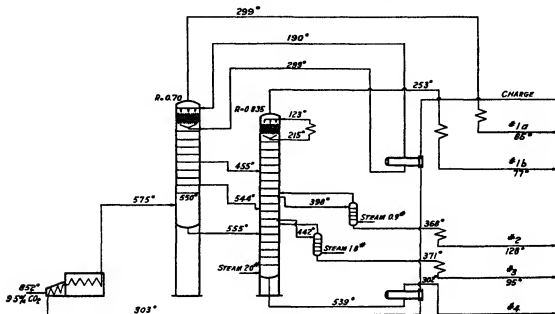

FIG 33

UNIT SIMILAR TO '32' PLUS PRELIMINARY FLASH

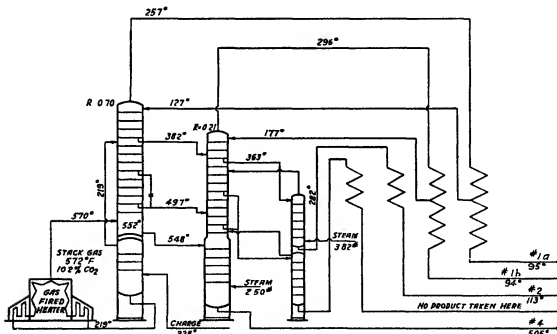

FIG 34

There are some practical advantages in the two-tower system in certain cases, especially when the percentage residue is large, but in general the single-flash unit is better for smaller, and the two-flash unit for larger capacities.

column from the top of which is taken the lowest boiling product. Heat can be furnished at the base of the primary column by circulating material through the heater and back to a lower plate of the column, open steam may also be

added at the base of this column to reduce the temperature of vaporization. The reduced crude from the first or heat exchanger flash is heated to the required temperature in the heater and flashed in the main topping column from which the heavier products are taken, as in the single-flash system.

This system has many advantages over the single-flash system, among which may be mentioned the following: The lightest cut can be taken off without steam, permitting low end-point products to be made without trouble from water condensing on the upper plates of the column.

primary column. In certain cases this may make the two-flash system less economical than the single-flash system, but in general a topping and vacuum or a three-stage system will be more economical than the single-flash system (see p 1595) in such cases.

Test data on the unit of Fig 35 for different degrees of separation in the primary tower are given in Table IX.

With low overflow-vapour ratios, $R = 0.30$ and 0.35 , at the top of the column, the overflow entering the feed plate from above was almost negligible, so that small variations in temperatures caused large variations in the distillation

SUCCESSIVE FLASH-TWO TOWER UNIT

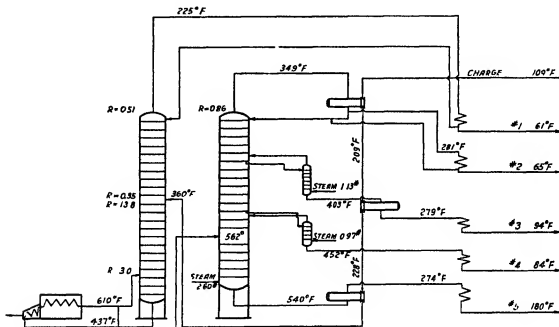

FIG 35

Certain corrosive materials can be removed in the small primary tower out of contact with steam and condensed water. Sharper separation can be made between the light cuts. Pressures on the heat exchangers are much lower and the charging pressure to the heater is lower.

When it is necessary to go to low bottoms, sufficient distillation steam may have to be added in the second column to make up for the light material removed in the

ranges of the products. As might be expected, the operation with these low ratios was somewhat irregular and the data on tests 1 and 2 are only to be taken as an indication of the overlap to be expected under conditions of minimum overflow.

Peters and Obryadchakoff [22, 1933] have worked out the separation to be expected in column 1 of the unit of Fig 35 using equilibrium curves adjusted for A S T M distillations. Their results checked the plant operation surprisingly well. However, the facts that separate equilibrium curves must be used for the upper and lower parts of the column and that, in the run considered, R varies from 0.51 at the top to 0.35 just above the feed plate, and from 13.8 on the feed plate to 3.0 at the base, and that assumptions must be made as to conditions at the feed plate, all together make calculations by this method so much a matter of judgement that it is doubtful if they have much practical value at the present time, except for columns in which rather narrow cuts are being re-run.

An approximate idea of the heat required to make separations with different degrees of sharpness can be obtained from tests 3 and 4 above, and from the data on the units of Figs 30, 38, and 29.

The important data on these tests are tabulated below. Data from tests 3 and 4 of the units of Fig. 35 are added for comparison.

TABLE IX
Separation in Two-stage Unit

Test no	1	2	3	4
R at top of primary column	0.30	0.35	0.51	0.68
A S T M end-point of overhead from primary column, °F	358	405	307	307
A S T M initial of overhead from secondary column, °F	307	396	307	340
Material in secondary column overhead by T B P analysis below A S T M end-point of primary column overhead, %	49.2	38	18.65	5.6
Yield primary column overhead % by wt		21*	14	13.8
Yield secondary column overhead % by wt		5*	8	8.3

* Approximate figures for yield taken from T B P curve of crude

TABLE X

Comparison of Reflux Ratios and Separations in Topping Units

	Fig 30	Fig 38	Fig 29	Fig 35	Fig 35
Overhead cut, % of charge	27.54	11.4*	20.3	149	13.8†
Second cut "	1.92	3.9†	16.6	8†	5.2†
R at top of column	0.715	0.865	0.866	0.51	0.66
R at second cut draw off	0.595	0.62†	0.719		
Number of plates between top of column and second cut draw off					
Steam in side stripper, lb per bbl side cut	3	7		22	22
Gap by A. S. T. M. distillation, °F	19.6	0	0	0	0
Overlap by T. B. P. ‡	9	-16	19	0	33
% of material (based on charge) boiling below A. S. T. M. end-point of overhead that appears in second cut	7.85	15	3.0	18.65	5.6
	0.70	0.98	0.5	1.50	0.46

* Based on charge to secondary column
 † Per cent by weight. All other percentages are by volume
 ‡ Percentage in heavier cut by T. B. P. boiling below the A. S. T. M. end-point of the lighter cut

A direct comparison between the different sets of data presented above is difficult because there are too many variables, and too many assumptions have to be made about the method of recovering heat. A very rough comparison may be made on the basis of the following assumptions. First, that no reflux heat at the top of the column is to be recovered. This is a fair assumption because heat can often be recovered more economically from other points in a unit than from the primary column vapours. Second, that steam for stripping be charged at one-third of its latent heat, this assumption being made on the basis that exhaust steam is used at a value of one-third that of live steam. Third, that it will be economical to recover heat from the column at the level of the second cut draw-off.

Comparing, first, tests 3 and 4 of the unit of Fig. 35, it is seen that an increase in overflow-vapour ratio from 0.51 to 0.68, representing a difference in heat input to the unit of 850 B Th U per gal of overhead of sp gr 0.72 and having a latent heat of 135 B Th U per lb, increases the recovery of end-point material by $1.04 = 7.5\%$, or, 1 gal of additional overhead costs $\frac{850}{0.07 \times 5} = 11,300$ B Th U.

Approximately the same recovery of overhead is obtained in the units of Figs 29 and 38, but (on the above assumption that the reflux heat at the top of the tower is wasted) this recovery requires 3,500 B Th U more per gal of overhead than is required by the unit of Fig. 35.

The arrangement of Fig. 30 produces results in the range of those from Figs 38 and 29 and test 4 of the unit of Fig. 35.

It will be noted that the overflow-vapour ratio for the unit with strippers (Fig. 30) is less than that for the units without strippers (Figs 29 and 38), but more than that for the double flash unit (Fig. 35). The heat equivalents for

TABLE XI
Heat Equivalent of Reflux

R	B Th U per gal net overhead products
0.51	834
0.68	1,700
0.715	2,000
0.865	5,126
0.866	5,170

the different amounts of reflux are tabulated below. It is assumed that the latent heat is 800 B Th U per gal in all cases.

The heat equivalent of the steam used in the stripper of Fig. 30 is almost negligible, especially on the assumption that only one-third of the latent heat of the steam is charged against the operation. 1.75 lb steam per bbl charge = 0.15 lb steam per gal net overhead = 49 B Th U per gal net overhead.

In general, it may be stated that the system of Fig. 35 will give the sharpest separation between two adjacent cuts, but that the system of Fig. 30 will give very sharp cuts if the overflow-vapour ratio and the number of plates in the column are increased. There is a practical limit to the separation that can be obtained in a side stripper with open steam. To go beyond this limit it is necessary to put heat into the base of the stripper. A unit similar to that of Fig. 30, with many plates and heat in the base of the stripper, could be made to accomplish any separation required, and from the standpoint of separation only would be preferable to the unit of Fig. 35. The latter unit is desirable on account of practical considerations not directly connected with sharpness of separation of the products.

Two-stage Topping and Vacuum Units

Limitations to Operation at Atmospheric Pressure. The percentage of distillate that can be obtained from a topping unit operating at atmospheric pressure is limited by several practical considerations. The charge cannot be heated above a certain temperature without loss of viscosity in the heavier fractions and loss of quality in regard to both stability and colour in the lighter fractions. Primrose [24, 1931] states that at a tube-still outlet temperature of 750° F the gasoline from Seminole crude was +30 colour and the kerosene +24. At higher temperatures the colour of these streams gradually fell off, and at 800° F tube-still outlet temperature the gasoline was 22 colour and the kerosene 17 to 18 colour. The exact temperature at which the colour is affected will vary with the crude run and the construction of the heater. In general, it may be assumed that the maximum is 750° F for the heater outlet and about 720° F for the vaporizer, although some refiners obtain products they can sell when operating at higher temperatures.

With this upper limit for the vaporizer temperature, it would be possible to vaporize a certain amount from any given crude without steam at atmospheric pressure, if more distillate were required, the pressure in the vaporizer would have to be lowered or an inert gas such as (superheated) steam added, to lower the partial pressure of the oil vapours. It is not usually practical to operate a topping unit under vacuum because the light vapours cannot be condensed with cooling water. It is often economical to use steam which may be available from the pumps of the topping or other units in the plant up to about 25 lb per bbl of crude charged. The unit shown in Fig. 31 used 29.6 lb steam per bbl in the vaporizer, and Vobach [26, 1928] reported 19 lb of steam to the vaporizer per bbl crude charged in a similar unit. Peterkin [20, 1928] proposed to use 21 lb steam per bbl running with a pipe-still outlet of 800° F. The vapours making up the lighter 90% of the Mid-Continent crude will run about 1.3 mol per bbl crude. Assuming a pressure of 2½-lb gauge, 890 mm abs, in the vaporizer, the partial pressure of the oil vapours would be reduced to $\frac{890 \times 1.3}{2.7} = 430$ mm by the use of 25 lb steam per bbl. At this pressure and a

vaporizer temperature of 720° F about 84% would be vaporized from a 37° API Mid-Continent crude. In order to vaporize 92% at the same temperature, the partial pressure of the oil vapours must be reduced to about 60 mm, requiring 350 lb steam per bbl of crude. While it is entirely possible to vaporize 92% of the crude with steam at atmospheric pressure, it is not economical.

Another practical objection to the single-flash distillation for low bottoms is the high fuel consumption. As mentioned on p 1595, a single-flash unit, with the conventional arrangement of heat exchangers, running to about 20% bottoms on Mid-Continent crude, would use about 2.65% fuel based on crude charged. Vobach [26, 1928] reported a fuel consumption of 2.96% on the single-flash unit running to 17.1% of 635 SR stock from a 41.2° API Pennsylvania crude. The amount of fuel given by Vobach is greater than would be calculated from the data given, namely, crude to heater 259° F, from heater 753° F., steam per bbl crude 19 lb superheated to 590° F., flue gases 420° F 8.5% CO₂, reflux to top of tower 1.06 bbl gasoline at 75° F per bbl crude charged. The amount of reflux given indicates that there is considerable excess vaporization at the vaporizer, probably necessary to get the required flash on the cylinder-stock bottoms. Assuming a radiation loss of 8% from the heater and 17% loss in the flue gases, a fuel consumption of 2.96% would give approximately 135,000 B Th U heat input per bbl charge to the oil and steam. Certainly this figure is a maximum for single flash and represents operation with low recovery of heat in the exchangers.

Primrose [24, 1931] gives some data on the operation of an atmospheric unit running Seminole crude to 9.8% bottoms with a heater inlet of 350° F, outlet 800° F, superheated steam 750° F. It may be estimated that the heat to the oil and steam for this operation is 115,000 B.Th.U per bbl, which with an overall heater efficiency of 65% would give a fuel consumption of about 2.9%. This compares with the two-stage vacuum unit described by Primrose [24, 1931] which required 2.35% fuel to go to 6.89% residue on Seminole crude, or the combination shell-still and vacuum unit of Figs 26 and 39 in which 1.89% fuel was required to go to 13.6% bottoms on East Texas crude.

The single-flash unit described by Peterkin (see p 1592), in which the maximum heat was recovered from the products, would operate with 106,000 B Th U per bbl charge when running with a pipe-still outlet temperature of 800° F, and if the maximum heat was recovered from the tower also, as he proposed, this might be reduced to 87,000 B Th U per bbl. This second figure is approximately the heat required in a two-stage unit with rather less than normal heat recovery in the exchangers.

There is no absolute theoretical basis on which the single-flash and the two-stage unit can be compared as regards fuel consumption. At the limit when the maximum heat was recovered from towers and products of each unit, the heat requirements might be about the same. But for arrangements of heat exchangers ordinarily considered practical to-day it may be assumed that the two-stage unit will use less fuel than the single-flash unit for operations requiring vaporizer temperatures higher than 600° F with moderate amounts of steam.

The Two-stage Unit.

The division of the duty between the stages of a two-stage unit presents the opportunity for wide variations in

design. Primrose [24, 1931] suggests that 'To always insure good colour of the lighter products, as well as an increased yield of overhead cylinder stock of higher flash, a vacuum flash chamber should be installed as an auxiliary to the main tower'. Assuming that the vaporizer temperature must be limited to 720° F in order to ensure good colour, the amount that can be flashed subsequently will be limited by the pressure on the vacuum-flash tower and by the temperature of the bottoms fed to this flash tower. This temperature will be reduced as the steam to the base of the atmospheric tower is increased. Theoretically there is no limit to the reduction of pressure in the flash tower. Distillations without steam were carried on commercially many years ago at absolute pressures of 2 or 3 mm. With open steam the pressure is generally limited to about 40 mm by the temperature of cooling water available, unless a booster ejector is used, in which case it is practical to get down to 10 mm to 20 mm abs. In general, the auxiliary flash tower will have rather limited use and will probably be most practical as an addition to an existing atmospheric tower where a small additional amount of heavy overhead is required. The addition of a flash tower to a vacuum unit would usually give a negligible increase of distillate. As Primrose states [24, 1931], 'The increase yield of cylinder stock (from the auxiliary flash tower) is so small that the advisability of the increased investment would depend largely on specific conditions'. Actually, the same investment applied to the main vacuum unit would probably produce a greater yield of distillate. This auxiliary vacuum-flash tower is, of course, a vacuum stage with the heater omitted.

With the addition of a heater, the charge to the vacuum unit can be brought to any desired temperature. When the required distillate can be obtained at reasonable pressures with temperatures below 700° F, the problem is simply one of balancing equipment size against fuel, steam, and power consumption, with all the variables easily determinable. But if temperatures above 700° F are required, or if, as is more generally the case, it is desired to obtain the maximum yield of overhead distillate, all the variables are not easily determinable and the problem becomes extremely complicated. The principal difficulty is that the heavier portion of the crude does not vaporize to any appreciable extent under conditions which can be obtained in the plant, or even in the laboratory. Various investigators have found it impossible to obtain appreciable amounts of distillate from compounds with molecular weights higher than 800 to 1,000. Carothers, Hill, Kirby, and Jacobson [5, 1930] came to the conclusion that probably no organic compound with a molecular weight higher than that of Heptacotane (mol wt 983) could be distilled under any experimental conditions, however favourable. Their conclusion was based on a comparison of the molecular cohesion and the latent heat, using values calculated by Dunkel [7, 1928]. Since they used latent heat values for normal boiling-points instead of for the temperature and pressure in question, it would appear that the agreement between their experimental results and Dunkel's calculations is fortuitous.

Burch [3, 1929] was able to distil compounds from Pennsylvania petroleum which had molecular weights of 801 as determined by cryoscopic methods, and was unable to obtain distillates with higher molecular weights, using a molecular still.

Data on the boiling-points of hydrocarbons with molecular weights above 500 are fragmentary and inconsistent. Flash vaporizations of many different reduced crude

samples indicate that about the 1,150° F point on the T B P curve (extrapolated on the basis of Wilson's chart) is close to that above which no appreciable distillate can be obtained by methods so far tried. Fig 36 shows the T B P and flash curves for a 46% reduced Mid-Continent crude (For operating data see end of article) The boiling-points for the curves of Fig 36 were reduced to atmospheric equivalent pressure by the Wilson chart. The T B P curve is extrapolated above 900° F, and the flash curve is estimated above 1,100° F. Both curves are open to question in the higher ranges. The T B P curve is shown running into the vertical line at a slight angle. Since the apparently non-volatile residue will hold some volatile material in the liquid phase regardless of the (theoretical) temperature or pressure at which a flash vaporization is made, the flash curve would cross the upper end of the T B P curve as shown.

The hypothesis that the residue above a molecular weight of 1,000 is practically non-volatile, or at least that its vapour pressure is extremely small, is supported by a large amount of data obtained in the laboratory of E B Badger & Sons Company, and this hypothesis explains many apparent inconsistencies in the results obtained in distilling petroleum under extreme conditions of vacuum and temperature, especially the differences in yields obtained with and without a stripping section for the residue. As mentioned on p 1581, an equilibrium curve can be calculated for a distillate by Murray's method which closely approximates the curve determined experimentally, and this curve is nearly a straight line. If it is assumed in this calculation that the vaporization is made in two successive steps, the first without steam, and the second with steam or other inert gas, the final resulting residue as calculated will be less in amount than if a single flash were assumed under conditions such that the pressure was equal to the partial pressure that would result if the steam in the second step had been brought to equilibrium with the material flashed in both steps of the successive-flash vaporization.

This may seem an arbitrary assumption having little relation to any practical method of distillation, but actually it approximates the conditions existing in a flash-distillation unit where the residue is stripped with steam. In such a unit it is usually considered, first, that the vapours from the stripping section come to equilibrium with the whole charge in the flash-vaporization zone, and second, that there is some selective vaporization due to the counter-current flow of residue and steam in the stripper. Possibly in a very small unit there may be some effective contact between the vapours from the stripper and the flashing charge, but the effect of this contact in larger units must be negligible. The increase in yield in the stripper due to counter-current flow may not be negligible, but it would not be sufficient to be noticed in any test data available.

The assumption regarding the two successive flashes

and the equivalent single flash will be made clear by an example. Assume that 100 lb per hour of the pressed distillate of Fig 39 is to be distilled to obtain 80% of distillate. The required temperature for a single-flash distillation at 760 mm pressure will be 755° F. The molecular weight of the distillate will be approximately 310 and there will be 97 mols per hour of distillate. Assume that the distillation is to be carried out at 525° F, from the Wilson chart (Fig 24) it is seen that a pressure of 30 mm on the oil vapour

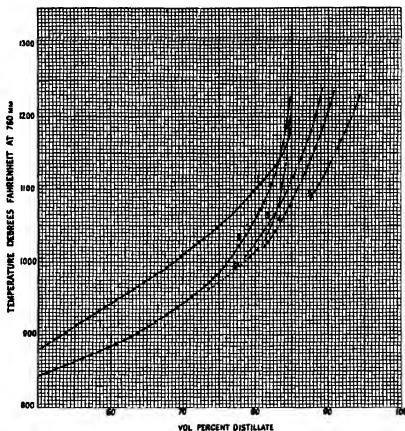

FIG 36 T B P and equilibrium flash distillation curves for 46% reduced Mid-Continent crude

- Curve 1 T B P curve
- Curve 2 Equilibrium flash curve for no cracking
- Curve 2A Equilibrium flash curve without cracking Bottoms stripped with inert gas in single-plate counter-current stripper
- Curve 3 Equilibrium flash made at 750° F
- Curve 4 Equilibrium flash made at 760° F
- Curve 5 Equilibrium flash made at 780° F

is required. If the pressure in the vaporizer is 60 mm, there will be required 97 mols of steam per hour to give a partial pressure on the hydrocarbon vapours of 30 mm. A single flash, then, at 525° F with a total pressure of 60 mm at the vaporizer and 97 mols of steam will produce 80% of distillate. Next assume that an equilibrium flash vaporization of the same material is made at 525° F and 60 mm pressure with no steam and that the residue is then flashed in equilibrium with 97 mols of steam at 525° F and 60 mm pressure. The equivalent temperature at 760 mm for the first flash, converted by Wilson's chart, would be 708° F, and there would be vaporized 25% with an average molecular weight of about 285, leaving 55%, or 71 mols, to be vaporized in the second flash. The calculations show that more than 97 mols of steam, or a temperature higher than 525° F, will be required

to vaporize this amount from the first flash residue, or conversely, if 97 mols of steam are used at a temperature of 525° F and a total pressure of 60 mm, there will be vaporized less than 71 mols per hour from the first flash residue. It should be kept in mind in the above discussion that yield of distillate only was considered and not composition of distillate and residue as it might affect flash-points. On the basis of such calculations it would be expected that, for vaporizing a distillate, steam in a stripper would not be as effective for measuring the gross yield of distillate as the same steam added in the vaporizing zone, provided complete equilibrium could be obtained in the vaporizing zone. No experimental data is available to substantiate these calculations, and the differences are so small that it will be difficult to find them in an operating unit.

If Murray's method is applied and a boiling-point is assumed for the final fraction on the basis of an extrapolated T B P curve, the calculated equilibrium flash curve turns out to be nearly a straight line quite similar to the curve for a distillate. Even if the final fraction is assigned a boiling-point well above any figure that might reasonably be obtained by extrapolation of the T B P curve, the calculated equilibrium flash curve will not be greatly curved up to 100% vaporized. Furthermore, the calculated yield of distillate will be greater by single flash than by two successive flashes, one without and one with steam, equivalent to the single flash as described above for distillates.

Both of these calculated results for residues are at variance with experimental data. The actual equilibrium flash curve for all residues turns up very sharply at the heavy end, and the yield of distillate by two successive flashes, one without steam and one with steam, is greater than that obtained in an equivalent single flash in which the steam is brought into equilibrium with the total distillate.

If that part of the residue boiling above about 1,150° F is assumed to be non-volatile, an equilibrium flash curve calculated by Murray's method closely approximates to the experimentally determined curve, and the calculated yield of distillate by two successive flashes, the second with steam, is greater than the calculated yield for a single flash under equivalent conditions. The exact point on the T B P curve above which the residue should be assumed non-volatile will be different for different types of crude. Sufficient data is not yet available to enable this point to be predicted for any crude.

It is extremely difficult to obtain accurate data on the vaporization of the heavy fractions of petroleum because the rate of cracking becomes large compared with the rate of vaporization obtainable under any conditions of vaporization so far known. Whenever a distillation is carried out at a temperature above about 700° F appreciable cracking will take place and the point representing yield of distillate up to, or at, a given temperature for batch or flash distillation will lie to the right of the curves representing the yields of distillates for conditions under which no appreciable cracking takes place. The displacement to the right will represent the amount of cracking. According to the Beale and Docksey chart, 700° F at 10 mm., 1 mm., and 0.1 mm equals 1,045° F, 1,190° F, and about 1,330° F respectively at 760 mm. It is evident that the point of practical non-volatility cannot be approached closely in the usual plant operation without using temperatures that will cause cracking. Actually, in a well-

designed unit the cracking that takes place for heater outlet temperatures of 750° F and below is negligible, but 750° F heater outlet means not over 690° F vaporizer temperature. At this temperature and a partial pressure on the hydrocarbon vapours of 10 mm corresponding to a temperature of 1,030° F at 760 mm by Beale and Docksey chart, there would still remain 6.7%, based on reduced crude, of distillate product in the residue of the 46% reduced Mid-Continent crude. The pressure might be reduced to 5 mm or even 3 mm at the vaporizer without running into prohibitive costs for equipment and steam, but even at 3 mm and 690° F, equivalent to 760 mm and 1,115° F by Beale and Docksey chart, there still remains 2½% volatile and 15% practically non-volatile residue.

It is found that this residue can be easily reduced by raising the temperature to a point where appreciable cracking takes place. Apparently the heavier part of the charge breaks down to form volatile products in the lube oil range with properties so similar to those of the uncracked material that the alteration can usually be detected only by careful measurements of the viscosities of all the products and by the formation of small amounts of lighter products and gas. It is probable that the character of the products varies according to the temperature and the time of heating. Curve 2 in Fig 36 represents the yields obtained under conditions that give substantially no cracking, curves 3, 4, and 5 represent yields of distillate obtained with increasing degrees of cracking. For curve 2 the vaporizer temperature was held below 715° F. For curve 3 the vaporizer temperature was 750° F, for curve 4, 760° F, and for curve 5, 780° F. The gas formation varies with the volumetric capacity of the vaporizer and the heating coil and transfer line, so that consistent results can only be obtained from runs made in the same or similar apparatus. Curve 2a in Fig 36 shows the yields to be expected when the residue is stripped with steam. The equivalent temperatures at 760 mm are based on an equivalent single flash in which steam equal in amount to that used in the stripper is assumed to be in equilibrium with the total charge material at the temperature and pressure existing in the vaporizer.

There are so many variable factors and so many methods of operating a vacuum unit that little accurate data on the various methods are available. The following conclusions have been drawn from test runs on plant units, checked against laboratory results.

(1) Where temperatures are below the cracking-point, the yield of distillate by single-flash vaporization depends only on the temperature and total or partial pressure of the hydrocarbon vapours, and the points represented by yields of distillate plotted against temperature reduced to 760 mm by O G Wilson's, Beale and Docksey's, or other reasonably accurate conversion chart give a smooth curve.

(2) For temperatures above the cracking-point, the yield of distillate will be increased for the same equivalent temperature at 760 mm as the actual temperature at the vaporizer is increased. It is possible that, for a given equivalent temperature, the distillate yield will increase as the actual temperature and pressure increase only up to a certain point, beyond which a decrease of distillate may be found due to coking of the residue.

(3) Yields of distillate will be the same for the same total or partial pressure in the vaporizing zone, regardless of whether the pressure on the hydrocarbon vapours is obtained by direct reduction of pressure on the system or

by adding steam or other inert gas. Kerosine, or any hydrocarbon boiling well below the boiling-point of the material to be vaporized, acts exactly the same as an equivalent volume of steam or any inert gas. When steam is added in the tubes of a heater, it is effective in producing the full vaporization to be expected at the resultant partial pressure. Steam added in the transfer line, especially in large amounts, does not come into effective contact with the hydrocarbon, and the vaporization produced may be considerably less than anticipated for the resultant partial pressure. In small (laboratory or semi-works) units, steam added in the transfer line has been found nearly 100% effective.

(4) Where the residue is run through a stripping tower countercurrent to steam, kerosine, or any other effectively inert gas, the total yield of distillate will generally be somewhat greater than that obtained in a single equilibrium flash made at the same vaporizer temperature and a pressure equivalent to the partial pressure of the total distillate product in the presence of the inert stripping gas at the vaporizer.

Calculations by Murray's method show that the increase in yield of distillate obtainable by the stripping section will reach a maximum a few per cent short of the point where the T.B.P. curve becomes vertical. Curve 2A, Fig. 36, shows the results to be expected from a stripping section according to calculations by Murray's method.

(5) An increased yield of distillate can be obtained by recirculating bottoms through a heater and over a stripping tower. A minor part of this increase may be due to the higher average temperature which can be maintained in the stripper due to the heat carried by the recirculated bottoms. In most cases the greater part of the increase is due to cracking of the heavy residue. Where the properties of the residue are important, as, for example, in the production of asphalt, there may be an advantage in keeping the maximum temperature to which the charge is subjected as low as possible. H. Van de Waerden in Brit. Pat. 361,173 (accepted 19 Nov. 1931) proposes to produce very high melting-point asphalt by recirculation through a heater and over the plates of a steam stripper. In this process the recirculated residue acts as a heat carrier, allowing the temperature in the stripper to be kept high with a low maximum temperature in the heater. Whatever cracking takes place during the reheating of the heavy asphalt does not appear to affect its quality, and there is evidence indicating that the same results cannot be obtained by running the charge once through the heater and raising to a temperature high enough to reduce the bottoms to the percentage of high melting-point asphalt obtained by Van der Waerden's process.

Coubrough in U.S.P. 1,980,612 (issued 13 Nov. 1934) describes a method of distillation in which residue is recirculated through the heater with the original charge.

In U.S.P. 1,905,156, 1,991,791, and 1,991,792 Coubrough suggests the use of a light hydrocarbon carrier

to aid in the vaporization of the heavier portions which may be described as distillate. There is no indication that a light hydrocarbon will be more effective in producing vaporization than an equal volume of any inert gas, such as steam. The specific volume of the hydrocarbon vapour must be low, usually it will be less than one-tenth that of steam. There may be some cases in which the hydrocarbon carrier will be economical, but in most cases the desired results could be obtained with steam at a far lower cost for fuel and equipment.

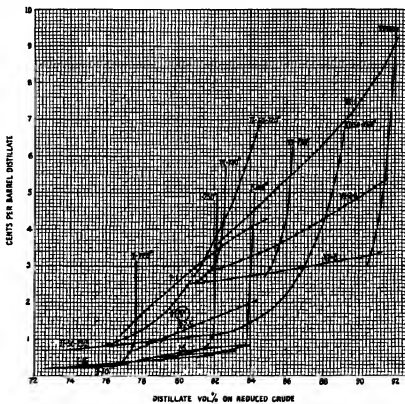

FIG. 37. Approximate relative utility costs of distilling 46% reduced Mid-Continent crude to various percentages bottoms by various methods.

(6) For stripping towers with three or more plates there appears to be no advantage in superheating the steam unless the quantity of steam is very large compared to the quantity of residue. For example, with 4,000 lb of steam to 16,000 lb residuum, no appreciable gain would be made by superheating the steam, but with 4,000 lb of steam to 1,600 lb of residuum there would be a gain.

Design of Vacuum Units.

It is evident from the points brought out above that the design of a vacuum unit may be subject to almost infinite variations in pressure, temperature, use of steam in heater tubes or transfer line or stripping tower, use of light hydrocarbons instead of steam, &c. In each particular case the choice of operating conditions will be determined by the desired degree of cracking, if any, by the separation required between the products, and by the relative costs of high pressure and exhaust steam, electricity, fuel, water, &c.

In order to show the relative importance of some of the factors entering into the design of a vacuum unit, the variable utility costs for distilling the reduced crude of Fig. 36 by several different methods are given on the chart,

Fig 37 (For operating data see end of article) These costs are based on the following assumptions regarding costs for utilities

Exhaust steam	12 cents per 1,000 lb
135 lb gauge steam	30 " " "
Water at 85° F	0.5 cents per 1,000 gal
Electricity	0.75 cents per K W H U
Fuels \$1 per bbl or approximately 25 cents per million B T h U absorbed	

Vacuum equipment to remove 100 lb per hour of gas of sp gr 1 will require steam and water as follows

TABLE XII

Dry Vacuum System using Steam Ejectors Pressures in Distillation Unit given in mm Mercury

Pressure at ejectors	Steam at 135 lb	Water for inter- and after-condensers	Cost of steam and water per 100 lb gas
mm	lb	gal	\$
1	7,500	75,000	2.62
2.5	3,200	32,000	1.12
5.0	1,260	8,400	0.42
10	800	5,400	0.27
15	700	4,200	0.23

Dry Vacuum System using Reciprocating Pumps

Pressure	K W H	Cost of Power
15 mm	38	50.28

The mechanical vacuum pump is more costly than the ejector when lower pressures are required. In some cases combinations of ejectors and mechanical pumps may show a saving, although the first cost will be greater and the mechanical pumps require skilled attention

TABLE XIII

Distillation with Steam

Pressure	Steam at 135 lb	Water for inter- and after-condensers	Temp rise main barometric condenser
mm	lb	gal	° F
40	1,400	6,900	5
45	1,025	5,500	8
50	835	4,500	10.5

Booster Ejectors.

To raise the pressure on steam from the final tubular condensers from 25 mm to 50 mm pressure will require approximately 0.9 lb of 135 lb steam per lb of steam to the booster

To raise the pressure on recirculated steam from 50 mm to 85 mm pressure will require approximately 0.8 lb of 135 lb steam per lb of steam to the recirculating booster

TABLE XIV

Product	% by vol on charge
Gas oil	4
Wax distillate	44
Light lube	22
Heavy lube	14.3
Residuum	15
Gas	0.7 max

The yields of heavy lube and residuum and the amount of gas will vary according to the temperatures and pressures employed. It will be assumed that 0.5 lb gas per bbl is

produced when the vaporizer temperature is 725° F, and that the gas is doubled for each increase of 25° F

To separate the overhead products there will be required nine plates, if a single-stage unit is used. If the distillate is taken off in bulk from a primary stage, there will be required eight plates above the vaporizer of a secondary tower for separating the products. Pressure drops through the towers and condensers will be as follows

1.5 mm	per plate in towers
4 "	through condensers for dry distillation
10 "	" " for steam distillation
7 "	" " for distillation with kerosene

Data on six systems are given in Fig 37 and in Table XV on p 1606. Only the steam and water used in the ejectors and in condensing the distillation steam or kerosene are considered. The cost of one-half the fuel required to heat the charge from 700° F to the final distillation temperature is added as a variable cost. This is on the assumption that one-half of the heat required for the primary distillation can be recovered. Two-thirds of the heat required for the secondary stage distillation in case VI and all the heat for heating and vaporizing the kerosene in case V is charged to the respective operations. No heat can be recovered from the kerosene used in distillation, for it must be condensed at a low pressure and hence at a low temperature, or it will be less effective in vaporizing the charge.

The costs of the utilities and fuel considered are, in many cases, a relatively small part of the total cost of distillation, nor are these costs a constant proportion of the total costs, especially when the first cost of the equipment is considered. Nevertheless, the chart and table do give a fairly good picture of the relative merits of the different systems and of the practical and theoretical limits of each. It must be kept in mind that changes in the costs of steam and fuel, or in the products required, will change the relative distillation costs. The size of the unit will also have a great effect on the relation of utility to overall costs. In figuring the gas to be handled no allowance was made for air leakage. In a small unit this would be a relatively large item, especially in the case of dry distillation at low temperatures and pressures. In a large unit operating at high temperatures the air leakage in a well-built unit is negligible. In all units using steam in the towers there is a carry-over of gas oil into the barometric well. Most of this gas oil may be recovered in settling ponds, but there is some net loss in all units and a very large loss in some.

The systems considered are as follows

Case I. Dry distillation single stage. Pressure at ejectors 1, 2.5, 5, 10, and 15 mm. Pressure at vaporizer 17.5 mm, higher than at ejectors. Temperatures at vaporizer 720° F, 750° F, and 760° F.

It will be noted from Fig 37 that a decrease in ejector pressure from 15 mm to 5 mm gives more distillate at no great increased cost. Decreasing the ejector pressure from 5 mm to 1 mm greatly increases cost with the production of very little more distillate. This is because the pressure drop in the system, 17.5 mm, is large compared to the lower ejector pressures. The difference in cost with ejector pressures from 5 mm to 15 mm is negligible in the range of 72% to 82% distillate. In this case the highest pressure and highest temperature would probably be used.

This system is particularly characterized by the absolute limitation on distillate yield at the maximum distillation temperature. The yield cannot be increased by sacrificing throughput.

Case II. Distillation with steam in a stripping section

below the vaporizer. Pressure at ejectors 40 mm, 45 mm, and 50 mm. Vaporizer temperatures 720° F, 750° F, and 760° F. Curves 2, 3, 4, and 5 of Fig. 36 are based on scanty test data, curve 2A is derived by calculations based on a hypothesis for which there is as yet little proof. Most of the test data available indicates that the yield curve for flash distillation followed by stripping the residue with steam lies to the right of the single-flash curve, but the data is not complete enough to show how far to the right it should be placed. In the calculations for cases II, III, and IV, where a stripping section for the residue is assumed, the yields have been taken from curves 2, 3, 4, and 5 of Fig. 36 and curve 2A has not been used. This introduces an error and makes the comparisons in Fig. 37 and Tables XV and XVI somewhat too favourable to the dry-flash systems. Actually the curves for case II in Fig. 37 should be displaced to the right and an addition should be made to the yields given for cases II, III, and IV in Table XV. On the other hand, the residue from the dry flashes can be stripped at small additional expense, especially in large units.

In any case, the errors viewed from the practical standpoint will not be large and will not affect the conclusions drawn from the curves and tables, which are to be considered as very rough approximations only. On the chart only the lines for 50 mm pressure and 720° F and 760° F vaporizer temperature are shown. One line connecting the points on the temperature lines at 23.5 lb steam per bbl is also shown. The minimum costs by this system are not as low as in single-stage dry distillation, but the yield of distillate can be increased more or less indefinitely by adding more steam. For yields of distillate above 84% and below 87% this system is more economical than dry distillation either in single or double flash. This system is also more flexible than the dry distillation, as air leakage does not affect the operation so much and yield can always be increased (within reasonable limits) at a sacrifice of throughput. It will be noted from Table XV that the higher ejector pressure gives lower operating cost. At some point a little above 50 mm this will be reversed, as the added stripping steam required will more than offset the saving in ejector steam.

Case III. Distillation with steam as in case II, except that a booster ejector is used to reduce the pressure at the exit of the tubular condensers. This system shows more advantage when the pressure drop between vaporizer and ejectors is low. In the present case (see Table XV) the saving in stripping steam is more than offset by the booster steam. It is doubtful, in any case, if this system will show an advantage over case II for large pressure drops, or case I for low pressure drops between vaporizer and ejector, even if exhaust steam is charged at the same rate as pressure steam. In that case the system of case IV will generally show lower costs. The arrangement of the booster for case III is the subject of U.S.P. 1,619,348, issued to G. A. Kramer, 1 March 1927.

Case IV. Distillation with steam as in case II, except that the distillation steam is recirculated by a booster between the outlet of the tubular condensers and the stripper base. Only the amount of steam added in the booster will go to the barometric condenser. This system shows a little advantage over that of case II. It will show more advantage if exhaust steam is charged at a higher figure and if the pressure drop through the system is lower. In the present case it was assumed that the booster picked up recirculating steam at the pressure of the vapours to

the barometric condenser. In some cases lower steam consumption may result if the booster takes all the steam from the tubular condensers, compressing it to the point required for the stripper base. Excess steam and gas would then go to the barometric condenser and ejectors at the stripper-base pressure.

The main point in the comparison between cases II, III, and IV is that there is little, if any, advantage in the use of boosters under the assumed conditions, and such advantage as may exist is in favour of a recirculation system. A recirculating system is covered by U.S.P. 1,961,211, taken out by H. M. Graham.

Case V. Kerosine with a boiling range of 400° F to 500° F, molecular weight 180, is recirculated through the system to reduce the partial pressure in the vaporizer. In this case it is assumed that three additional plates are required to separate the recirculated kerosine from the lightest product cut. Pressure at the entrance to ejectors will be taken at 15 mm, at which pressure the kerosine can be condensed with small loss at a final condensate temperature of 150° F. The pressure at the vaporizer will be 43 mm. Since the kerosine is added with the charge to the vaporizer, it cannot be expected to have any greater effect than that due to the lower partial pressure resulting for the heavier hydrocarbons. One case only is considered for a vaporizer temperature of 750° F, partial pressure on distillate 28 mm, equivalent temperature at 760 mm 1,032° F, yield of distillate 80.2%. Steam, water, and fuel costs are 50% greater than the utility costs of case II to produce the same yield of distillate. Equipment costs will probably run more than 50% greater than those for case II, and both utility and equipment costs will run higher than for the dry distillation method of case I. It is possible that some extreme cases may exist where recirculated kerosine will give the desired results at the lowest cost or will be the only practicable method of getting results. For example, to obtain more than 92% distillate from the reduced crude of Fig. 36 would appear to be impractical by any of the methods considered. If it could be done with kerosine, the cost would be higher than the highest point of the chart of Fig. 37, and the cost for additional distillate above 92% would be very high. A rough approximation of the cost is given by the following example. To get 92% distillate requires a vaporizer temperature of 780° F and a partial pressure of 5 mm (equivalent temperature at 760 mm 1,189° F by Beale and Docksey chart). Assuming that the 180 molecular weight material could be condensed at 5 mm in the presence of the heavier material, the primary vaporizer might be run at 9 mm pressure, allowing a 4-mm pressure drop from condenser to vaporizer. There would be required 0.64 mol or 115 lb of kerosine per bbl of charge to reduce the pressure on the distillate from 9 mm to 5 mm. This kerosine must be heated and vaporized twice, once in the primary and once in the secondary system. Neglecting loss of kerosine due to cracking, the approximate cost of the utilities considered in Fig. 37 to obtain 92% distillate will be 6.6 cents per bbl distillate, or less than that required in case VI at 1 mm ejector pressure. To obtain 93% overhead would require recirculating 230 lb kerosine per bbl charge, and the relative utility costs would be 9.8 cents per bbl distillate. The extra distillate produced above 92% costs about \$3 per bbl for the utilities considered alone. Obviously such operations are beyond the range of practical refinery practice to-day.

Case VI. The charge is flashed first in a vaporizer connected directly to a condenser. All the distillate is

condensed at the highest practicable temperature and then recirculated and run to a second tower in which the products are separated. From the chart Fig 37 it is seen that this system is most economical in the range above 87% distillate. On the basis of the assumptions made there is a sharp limit to the yield of distillate obtainable by this method. However, if it were actually required to get above the break-point of 91% to 92% overhead, several operating conditions could be made more favourable than those assumed for this comparison. This system gives the most practicable means for getting the greatest yield of overhead in standard equipment. It is especially economical where exhaust steam costs are high.

Below are tabulated the relative utility costs based on the assumptions given above for obtaining 80% distillate by the various methods discussed.

TABLE XV
Approximate Relative Utility Costs to obtain 80%
Distillate

Method	Ejector pressure	Vaporizer pressure	Vaporizer temp	Steam or kerosene to stripper per bbl charge	Cost per bbl dist
	mm	mm		lb	cents
I	15	32.5	755		0.5
	10	27.5	750		0.53
	5	22.5	740		0.6
II	50	73.5	750	23.5	1.06
	45	68.5	750	21	1.16
	40	63.5	750	18	1.31
III	50	73.5	750	100	2.15
	25	48.5	750	3.5	1.2
IV	50	73.5	750		1.0
V	15	43.5	750	78	1.53
	1	5	750		3.0
VI	2.5	6.5	750		2.8
	5.0	9	750		2.5

The real problem in determining the economics of any particular operation is to find the extra cost for additional distillate produced by the cheapest method. Table XVI gives some figures on the cost of additional yields of distillate. These figures are to be taken as very rough approximations only, and it must be realized that they are based on assumed conditions that will be different in each plant, and for each charging stock.

TABLE XVI
Relative Utility Costs for Incremental Yields of Distillate

Range of yield	System of distillation	Cost per bbl distillate
		\$
0-73.0	Case I	0.002
73.0-83.7	" I	0.05
83.7-85.5	" II	0.55
85.5-87.0	" VI	0.60
87.0-90.6	" VI	0.11
90.6-92.0	" V-VI	2.20
92.0-93.0	" V-VI	3.00

The lower cost for the increment between 87% and 90.6% is due to the increase in vaporizer temperature allowed for case VI and the increase in distillate due to cracking at the higher vaporizer temperature.

In the preceding discussion no account was taken of the possible loss of viscosity of the distillate for the higher operating temperatures. It is found that at vaporizer temperatures above about 770° F., or lower if there is a considerable hold-up in the heater, the viscosity of the overhead will be appreciably less than would be the case

if the same yield were produced at lower temperatures. Thus in running for lubricating oil there would be a practical limit to obtaining an increased yield of distillate by increasing the temperature, and this limit would come at the point where the loss of viscosity due to cracking the total distillate more than overbalanced the additional yield due to cracking the heavy residue. For maximum yields of distillate of the highest possible viscosity the distillation should be carried out in three steps. For greatest economy the first might be a dry distillation according to the method of case I or case VI. In the second step residue from the first would be stripped of remaining volatile material in a steam stripper. In many cases these two steps would be combined according to the methods of cases II, III, or IV. In the third step the residue from the second, made up of material which was practically non-volatile, would be subject to controlled cracking, and the more readily volatile products, resulting from this cracking, removed, preferably by stripping with steam. The second and third steps can be combined and the residue progressively cracked by recirculating through a heater and over stripping plates as suggested by Van der Waerden. If all three steps are combined and the bottoms are recycled with the fresh charge as suggested by Coubrough, the original practically non-volatile material in the charge may be considerably reduced by cracking, and some of the advantages of the three steps will be obtained in the one unit.

No figures are available for the additional yields to be expected under given conditions by the second and third steps described above. It is probable that the cost of a small increment of distillate obtained by step two, or by a combination of steps two and three, will be lower in many cases than the costs for certain increments shown in Table XVI.

A great many patents have been taken out on various types of vacuum distillation methods and processes for obtaining high yields of distillate from petroleum. Data available at present indicates that the distillate can be increased by reducing the pressure, total or partial, and by stripping readily volatile materials from practically non-volatile residues, by increasing the temperature, and by cracking heavy residues. The increase due to pressure reduction, or to be obtained by stripping, appears to follow well-known laws applying to the vaporization of liquid mixtures. The increased yields due to temperature increases also follow these laws up to the point where appreciable cracking begins, above this point there is a greater yield of distillate than would be calculated from the properties of the original compounds present in the charge. There appears to be little room for advantage, except in a few special cases, from any of the patented methods so far made public, and such methods will, therefore, not be further discussed.

Separation of Cuts in Vacuum Units and Examples of Operating Limits.

In the foregoing discussion of methods of vaporizing the charge to a vacuum unit it was assumed that three plates per cut would make the desired separation. There are usually no definite specifications on the boiling range of cuts from vacuum units, and the design of columns has been entirely a matter of judgement, with no specific trend developing nearly 10 years after the first large vacuum towers were built.

In atmospheric distillation there is no great disadvantage in having extra plates in the column, the added cost is small, and the pressure drop is not important. In vacuum

not required between a wax distillate and slop-wax cut to give a maximum yield of pressable wax distillate. A stripper would obviously not help the wax-distillate cut, though a side stripper on the slop-wax cut might give a slightly increased yield of wax distillate.

improvement in open-cup flash-viscosity relationship. If the closed-cup flash is important, and it is not now apparent why it should be, a side stripper would probably be of advantage, regardless of the number of plates in the main column.

VACUUM UNIT WITH STEAM AND STRIPPERS

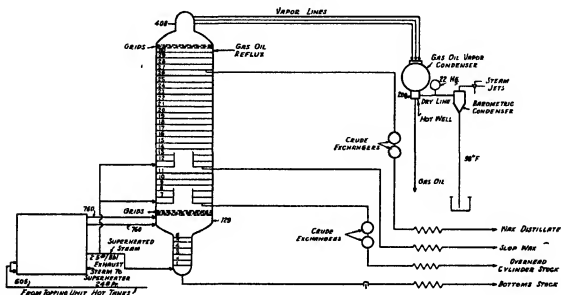

FIG 39

VACUUM UNIT WITH STEAM & SIDE STRIPPERS

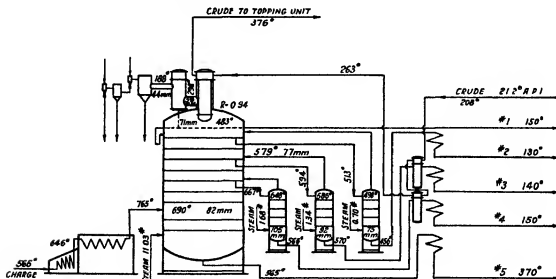

FIG 40

Where the maximum open-cup flash for a given viscosity is not required, and it seems evident that such a requirement is an arbitrary one having no demonstrable connexion with the value of a lube stock, it would appear that 2 plates per cut were sufficient. Where the maximum open-cup flash is required it would seem advisable to go to 3 plates per cut. It is doubtful whether, with 3 properly designed plates per cut, side strippers would show any

In spite of the great variation possible in arrangement and method of operation of vacuum units, one arrangement has come to be regarded as more or less standard. This standard unit is arranged to take off about 3 side cuts and to operate with open steam when running to low percentage bottoms. The vacuum section of the unit described by Primrose [24, 1931] was characterized as a general utility unit, and he gives data on its performance

with three different types of crudes. The column had 19 rectifying plates which must have led to a high pressure in the vaporizer. From the data presented below, it would seem that a column with 10 rectifying plates would have greater flexibility and that the side cuts would be well enough separated for all practical purposes with a lower pressure in the vaporizer.

Multiple-stage Units for Re-running Pressure Distillate

It had long been recognized that acid-treated pressure distillate gave a better product if the temperature was kept low during re-running. However, it was not until 1927 that the Gulf Refining Company determined that there was a definite decrease in quality of the distillate at temperatures above about 275° F. At about this temperature certain sulphur compounds broke up, forming low-boiling products which distilled over and lowered the colour and stability of the product. In the ordinary distillation of pressure distillate at atmospheric pressure, the temperature may be reduced to about 325° F, by recycling the bottoms and using a large amount of open steam. To keep the temperature below 275° F would require a very large amount of steam, and it is more practical to carry out the distillation in two or more stages, the second and any subsequent stages being under vacuum. The first units were to be built where the cooling water was quite warm, and were therefore designed for operation without open steam in the vacuum section. There were several practical difficulties with these units, and they were not quite as satisfactory as the next, which were built for open steam in both vacuum and atmospheric sections.

A comparison of the atmospheric re-run unit with and without recycled bottoms, with the atmospheric and vacuum unit, given by the Arthur G. McKee Company [15, 1931], is reproduced in Table XVIII.

Burdick and Woods [4, 1933] describe a unit with two vacuum stages designed to operate at 250° F. maximum temperature. They state that the steam required for stripping is one-third to one-half of that required in a two-stage unit, although no figures are given for comparison. It would appear that the comparison was made with a two-stage unit originally designed to operate at 275° F. which was later operated at 250° F. Actually, the amount of vacuum stripping steam can be reduced to zero as it was in the first units built, which were operated without steam. The number of stages used will depend on the size of unit and the importance of economizing heat. It is probable that for very large capacities a four-stage dry-distillation unit would give the best results.

Data on two operating units of a type that has become standard are given in Figs 41 and 42. (For operating data see end of article.)

Solution Re-run Units.

The method of distillation to be employed for the separation of solvent used in dewaxing or treating lube stocks will depend on many factors, chief of which are the boiling-point of the solvent, the maximum temperature to which the mixture is to be exposed, the number of fractions to be made. If the solvent only is to be distilled off, a low temperature will generally suffice. If some of the lube stock is to be taken overhead, or if it is desired to heat the charge in order to break up various compounds

TABLE XVIII

Technical Data and Utility Requirements when Operating for 437° F. End-point Gasoline

	Single flash	Recycle	Atm sec.
<i>Type unit temperatures</i>	° F	° F	° F
Charge to vapour exchanger	70	70	70
" pipe still (to steam heater on vacuum unit)	225	225	200
Charge from pipe still (from steam heater on vacuum unit)	375	325	275
Atmospheric unit vaporizer flash	350	325	275
Recycle to pipe still		300	325
" from pipe still		300	275
Bottoms from atmospheric tower	320	290	240
Exhaust steam to atmospheric tower	350	325	275
Vacuum charge to heater			275
from heater			275
Top of vacuum tower			210
Bottoms from vacuum tower			275
Exhaust steam to vacuum tower			275
<i>Pressures</i>			mm
Top of vacuum tower			65
Vaporizer section			70
<i>Utility requirements</i>			
Exhaust steam to atmospheric tower, lb per bbl charge	34.0	61.3	21.2
Exhaust steam to vacuum tower, lb per bbl charge			2.5
Total process steam (exhaust)	34.0	61.3	23.7
Live steam to pumps, lb per bbl charge	16.10	29.00	18.2
" to ejectors lb per bbl charge			9.2
" to fuel-oil burners, lb per bbl charge	3.36	3.06	
Total live steam	19.46	32.06	23.4
Cooling water, gal per bbl charge	234	323	224
Heat developed by pipe still B Th U per bbl of charge	6,300	5,710	3,920

Comparative Costs of Various Type Units

	%
(1) Atmospheric single flash—pipe-still unit	100
(2) Atmospheric recycle—pipe-still unit	110
(3) Combination atmospheric-vacuum unit (steam heated)	136
(4) Combination atmospheric vacuum pipe still unit (direct heated)	145
(5) Combination atmospheric-vacuum pipe still unit (indirect heated)	155

that would injure the finished oil if not decomposed, a high temperature may be required. In the case of a low-boiling solvent like sulphur dioxide the distillation may be carried out in many stages.

With the increasing use of solvents, the number of different kinds of units becomes very great, and a description of all the units in use would cover a large part of the general field of distillation. Only two examples will be given here.

Fig 43 shows a unit designed to remove naphtha from a cylinder stock without exceeding a temperature of 325° F. The cylinder stock was to be run to closed-cup specifications and all but traces of naphtha had to be removed. It was found that it took 10 times as much naphtha to affect the open-cup as the closed-cup flash.

Fig 44 shows a unit for removing naphtha from a solution in a conventional atmospheric single-flash distillation with steam.

Pressed Distillate Re-run Units.

In re-running pressed distillate it is desirable to get the maximum possible fractionation, for the most valuable product is the viscous neutral bottoms, and this product must be kept out of the side streams. Pressed distillate is usually run at atmospheric pressure, there being no harmful effect from high temperatures, in fact, Bahlke (U.S.P. 1,778,445) claims that a temperature sufficient to vaporize

DISTILLATION
CRACKED DISTILLATE RERUN UNIT-TWO STAGE

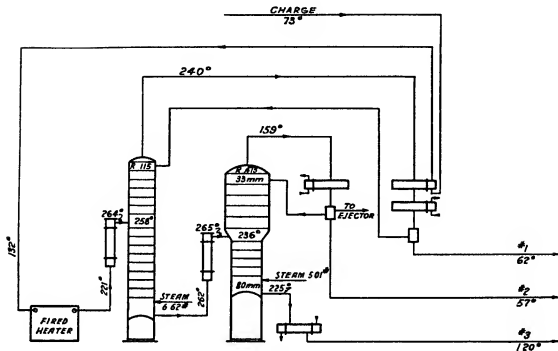

FIG 41

CRACKED DISTILLATE RERUN UNIT-THREE STAGE

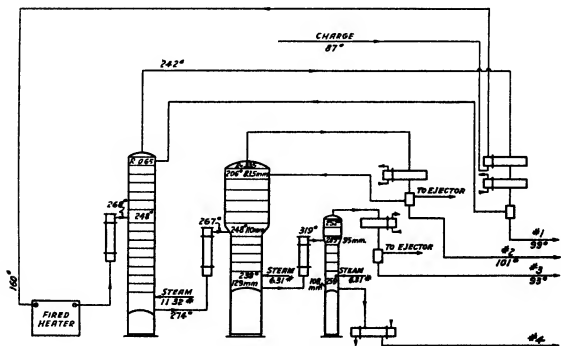

FIG 42

and superheat all the charge improves an acid-treated pressed distillate

Fig 45 shows the operation of a typical pressed distillate re-run unit (For operating data see end of article)

*BRIGHT STOCK SOLUTION UNIT
STEAM HEATED*

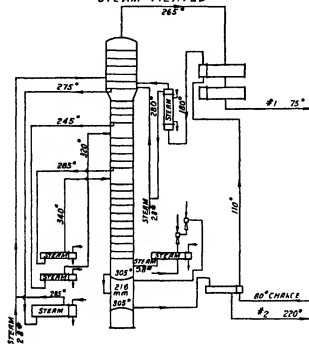

FIG 43

*BRIGHT STOCK SOLUTION UNIT
FIRE HEATED*

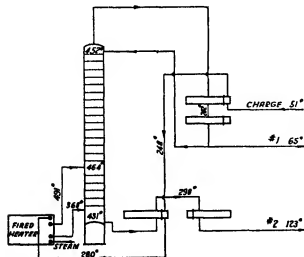

FIG 44

Trend of Design in the Future.

Peterkin [20] in January 1928 summed up the requirements for an ideal distillation unit as follows

'The heating element would waste as little heat as let us say, a steam boiler built along the most approved

lines, and operate with as great a heat input per square foot of heating surface

'The heat recovery equipment would be designed to recover in useful form the highest percentage of the heat input consistent with the desired separation of the constituents of the material under process. This means that heat would be recovered at the highest available temperatures and wherever possible from condensing vapours

'The oils produced would require no further distillation to render them suitable for processing of a different kind or for sale

'Each element of equipment not essential to the main purpose of the operation would effect an annual economy of, at least shall we say, one-fifth its cost'

*PRESSED DISTILLATE UNIT
SINGLE FLASH WITHOUT SIDE STRIPPERS*

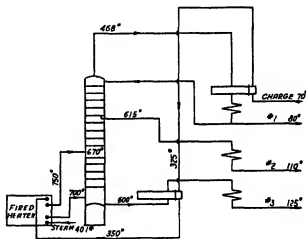

FIG 45

In the 7 years since there has been a great improvement in units as regards ease of operation, but no improvement in what might be termed the non-essentials of heat recovery and thermal efficiency. Improved column design and better arrangement of the parts of the unit have given the required products with less equipment, and much more attention has been paid to cutting down the capital cost and reducing the time for repairs and cleaning than to decreasing the fuel consumption. It might therefore be said again to-day that the tendency would be towards efficiency in the heater equivalent to that obtained in a good steam boiler, and to the highest possible recovery of heat. However, when waste or low value products no longer furnish sufficient fuel in the refinery, the heater will be fired with powdered coal or coke, and thermal efficiency will remain a secondary consideration until the relative costs of labour and capital decrease with respect to the cost of the cheapest fuel available.

As pointed out previously, heat can be recovered from the column at the expense of separation. There has been very little reason to design for sharper separations, and as long as the greatest portion of petroleum products is used as fuel, there may be no demand for much sharper cuts.

Of course, the proportion of lighter products used in the

chemical industries will increase and special units will be used to produce sharp cuts, but only of a relatively very small portion of the crude charged.

It is improbable that the primary distillation unit will change much for a long time. The vacuum unit will probably be designed to go to lower bottoms and at the same time to make sharper cuts. This will probably lead to the two-stage unit noted on p 1605, case VI, although whether this type of unit, or a unit with an efficient column which might be developed to operate with practically no back-pressure, is used would depend on relative costs.

The distillation of heavier residues may well be combined with a mild cracking to produce lighter lube stocks and Diesel fuels, and it might be that this type of operation

would supplant the present type of vacuum distillation to minimum bottoms.

Altogether it does not appear that there will be any great change in the primary distillation equipment in the near or intermediate future. The introduction of new solvents and new treating methods will require more distillation equipment, but equipment of a type that is in use at the present time. The greatest change in primary distillation equipment to be anticipated in the intermediate future, i.e. within 10 to 15 years, is the change-over from oil to a cheaper fuel in the refinery and an increased use of indirect heating methods to minimize cracking as products become more valuable and there is a tendency to greater refinements in processing.

Operating Data on Fig 26

Product	Gasoline				Kerosine			Gas oil	Bottoms
% yield			31.41			14.87		6.42	47.3
Stream	Fl 17	61	62	63	64	65	65 R		
Per cent	9.67	9.05	5.97	6.72	9.80	5.07	6.42		
Grav	68.4	61.7	63.0	54.1	43.2	39.2	35.7		24.4
I B P	93	97	104	154	331	398	469		
F B P	362	390	338	381	522	520	678		
5%	116	133	140	212	354	425	501		
95%	361	367	305	347	505	496	638		
140° F	14	6	5						
212° F	58	33	37	5					
400° F					30	1			
Colour				30	22	22			
Abel	30	30	30		118	86			
CT							20		

Capacity

% fuel

Lb steam per bbl

about 30,000 bbl per day

1.39

.19

Operating Data on Fig 27

Products	1 Gasoline	2 Naphtha	3 Kerosine	4 Gas oil	5 Wax dist	7 Cyl stk	Charge Pa cr	B Th U per bbl charge
Yield, % by vol	16.9	19.4	11.3	16.0	19.5	17.2	100.0	Heat input, exchangers heater
Gravty, ° API	76.3	53.3	45.0	39.0	33.7	26.0	44.0	49,470
A.S.T.M. distillation °F								94,500
I B P	80	268	368	530				Total heat input
F B P	257	398	525	649				143,970
5%	107	280	404	538				Heat to cooling water
10%	118	285	425	546				121,600
20%	136	290	437	555				Total distillation steam, per bbl crude
30%	177	312	455	575				34.7 lb
80%	206	348	476	610				
90%	238	367	488	626				
S U via					86 at 100° F	147 at 210° F		
O C flash, °F					285	545		

Operating Data on Fig 28

Products	1 Heavy naphtha	2 Gas oil	3 Lub stk	4 Residue	5 Gulf Coast crude	B Th U per bbl charge
Yield, % by vol	4.0	42.9	8.2	44.9	100.0	Heat input, exchangers
Gravty, ° API	38.7	26.8	20.5	16.4	21.6	" " heater
Engler distillation, °F						Total heat to charge
I B P	226	435			406	93,000
F B P	506					Heat to cooling water
5%	284	455			455	49,600
10%	306	470			489	Total distillation steam, per bbl charge
20%	330	491			536	4.24 lb
30%	368	543				
80%	410					
90%	440					
S U via at 100° F		45	414		221	
O C flash, °F			355			
F M flash, °F		200				

Operating Data on Fig 32

Products	1		2		3		4		Charge W Texas crude	Loss and slip	B Th U per bbl charge	
	1a	1b	Composite gasoline	Kerosene	Gas oil	Residuum	ASTM	ASTM			%	
Yield, % by vol	22.68	3.00	25.68	7.90	10.52	55.90					43,000	43.5
Gravity, ° API	57.5	49.0	55.5	37.8	33.1	20.8		30.7			56,000	56.5
Distillation, °F	ASTM	ASTM	ASTM	ASTM	ASTM	ASTM	ASTM	T B P				
I B P		190	112	416	445	481		26°-406			99,000	
F B P		406	406	548	694						55,000	
10%		264	192	440	493	603		30.8% - 437				
20%		284	230	446	511	645						
30%	284	324	298	462	549	675						
80%		352	356	486	603						5.04 lb	
90%		368	378	505	635							
% below 406 by T B P				9.71	3.00	0.58						
% " 437 " "				24.7	7.3	1.3						
Flash				195	225	300						
Fire				205	250	345						

Operating Data on Fig 33

Products	1		2		3		4		Charge W Texas crude	Loss and slip	B Th U per bbl charge	
	1a	1b	Composite gasoline	Kerosene	Gas oil	Residuum	ASTM	ASTM			%	
Yield, % by vol	20.96	4.19		17.08	8.29	47.02					38,700	38.5
Gravity, ° API	56.8	52.5		15.2	30.4	19.1		30.4			62,000	61.5
ASTM distillation, °F												
I B P	110	126		430	506	554	154				100,700	
F B P	400	404		664							39,000	
10%	183	220		460	530	640	318					
20%	216	234		470	546		400					
30%	288	313		498	588		620					
80%	350	359		550								
90%	374	376		624								
% below 400° F by T B P				3.35	0.5	0.21						
% " 437° F " "				21.65	2.3	0.405						
Flash				198	255	355						

Operating Data on Fig 34

Products	1		2		4		Charge W Texas crude	Loss and slip	B Th U per bbl charge	
	1a Gasoline	1b Naphtha	Composite 1a+1b Gasoline	Kerosene	Gas oil	Residuum			%	
Yield, % by vol	20.6	6.8	27.4	9.7	61.2	100			71,100	
Gravity, ° API	63.3	51.1		39.4	21.4	33.1			44,000	
ASTM distillation, °F										
I B P	102	137	111	392	434	132				
F B P	374	395	381	503						
10%	144	238	158	412	565	244				
20%	171	273	187	417	607	328				
30%	238	325	264	433	682	589				
80%	300	355	326	460						
90%	333	369	353	476						
T B P distillation, °F										
I B P				294	185	100				
1%				350	380	118				
2%				369		134				
5%				386		169				
10%				397		220				
20%				413		320				
30%						410				
% below 370° F				2.5	0.97	25.8				
% " 381° F				3.67	1.03	26.5				
% " 390° F				6.3	1.10	27.5				

Operating Data on Fig 35

Products	Charge					Charge	B T U per bbl charge		%
	1 Benzine	2 Naphtia	3 Kerovine	4 Gas oil	5 Residuum		Heat input, exchangers	Heat to cooling water	
Yield, % by vol	16.5	8.7	19.7				41,000		42
Yield, % by wt	14	8	19	6	53		56,000		58
Sp gr	0.72	0.78	0.82	0.85	0.94	0.85	Total heat to crude	97,000	
A S T M distillation, °F			455	577			Heat to cooling water	51,000	
I B P		307	595				Total distillation steam, per bbl	4.7 lb	
E P	307	415							
10%	162	328							
30%	203	341							
50%	226	352							
70%	230	369							
90%	278	394							
T B P distillation, % by vol									
At 307° F		18.65				17.7			
I B P		194° F							
1%		254				119			
2%		260				140			
3%		264				160			
5%		273				191			
10%		290				244			
15%		302				285			
20%		311				328			
30%		328				408			

Operating Data on Fig 38

Charging Stock Oklahoma City Crude

Yield, % by vol	Charge	Gasoline		Lt naphtha		Heavy naphtha		Kerosine		Atm gas oil		Vac gas oil		Wax dist	Slop wax	Residue	
		* 9.5	69.8	10.1	56.8	1.5	49.1	12.0	16.8	37.1	3.8	14.5	30.7	8.55	6.6	27.6	22.5
API gravity	36.8							43.9								21.1	
S U vis at 100° F																	
" " 210° F																	
Distillation, °F	T B P	ASTM	ASTM	T B P	ASTM	T B P	ASTM	T B P	ASTM	T B P	ASTM	T B P	T B P	T B P	T B P	T B P	
I B P	82	180	<116	322	208	367	191	470	536				612	675	938		
1%			145		266		280				393		441				
1.5%							367				430		488				
3%			155		302		367				449		506		643	728	
5%	180		219	166	331	321	389	378	498	449	551	506	643	753	902	879	
10%	231	136	228	190	334	312	396	386	507	479	556	532	656	788	935		
15%			201		338		390		492		547		669	800			
20%	233	158	238	212	337	342	404	395	519	504	563	553	678	815			
30%	423	166	248	234	340	346	410		529	519	569	565	692	832			
40%	505	190	257	256	343	348	415		538	519	575	575	712	849			
50%	593	202	265	272	345		420		549	580	578	578	726	850			
60%	691	218	276	286	347		426		560	585	584	584	747	860			
70%	800	232	285	296	349		432		575	591	592	592	760	875			
80%	822	250	296	307	353		441		598	598	594	594	775	882			
90%		280	309		359		453		631		608						
95%		318			366		463		662		617						
E P		326	338		380		492		690		632						
Recovery	97		99.5		99.5		79.5		79.0		79.0						
Residue			0.5		1.0		0.5		1.0		1.0						
Loss			0.5		0.5		0.0		0.0		0.0						

* Loss assumed to be 0.5%

	B T U per bbl charge	%
Heat to oil in atm heater	59,500	
" " vac "	19,000	
Total in heaters	78,500	66.8
Heat to oil in exchanger	39,000	33.2
Total heat to oil	117,500	
Heat out in cooling water	71,000	

Operating Data on Fig 39

Capacity		13,300 bbl per day				Typical Side Products	
% fuel		1.06				Wax distillate	
Lb steam per bbl		34				Wax stop	
Water consumption G P M		approx 3,500					
Pressure at vaporizer		about 105 mm					
Typical products	Gas oil	Crk stk wax dist	Slop wax	Crk stk old cyl	Bottoms stk	Test b Gravity, °API	
Test a						Pour °F	
% yield (on crude)	1.99	24.71		6.29	13.60	S U Vis at 100° F	30.5
Gravity	34.8	30.2		22.9	12.3	" " 210° F	75-80
C T	12	80		120		Flash	72
Vis at 100° F		83				T B P distillation, °F	320
" " 210° F				84	1,684	1*	
O C flash, °F		325		490		5 1/2*	513
M P bottoms, °F						10*	550
						20*	580
						30*	614
						50*	645
						80*	711
						90*	807
							839

Running for cracking stock

Operating Data on Fig 40

Products	1 Gas oil	2 Light lab oil		3 Medium lab oil		4 Heavy lab oil		5 Residue	Charge reduced Oil Count crude
		Before stripper	After stripper	Before stripper	After stripper	Before stripper	After stripper		
Yield, % by vol	7.3	20.4	7.5	18.5	39.4	11.0	18.4	34.7	100.0
Gravity, °API	22.2	360	385	435	450	503	550	11.1	16.8
O C flash, °F		290 at 100° F	352 at 100° F	77 at 210° F	84 at 210° F	155 at 210° F	203 at 210° F		
S U Vis									
T B P distillation, °F									
1%		620	655	685	720	725	862		
5%		665	685	745	758	803	906		
10%		688	707	764	778	849	929		
20%		712	724	789	798	887	949		
30%		749	756	827	836				
80%		788	793	887	898				
90%		810	810	922	926				

B T H U per bbl charge

Heat input, exchangers (to crude) heater 53 600
 Total heat to charge 46 600
 Heat to cooling water 68 200
 Total distillation steam, per bbl charge 14 75 lb

Operating Data on Fig 41

Note—Tubular heaters and stripping plates of towers heated by circulating oil

Products	1 Atm ohd	2 Atm bins	3 Vac ohd	4 Vac bins	Charge	Combined gasoline	B T H U per bbl charge	
							Heat input, exchangers oil	heater and circulating
Yield, % by vol	41.9	58.1	19.9	37.2	100.0	61.8	7,900	
Gravity, °API	66.9	40.3	49.0	35.8	50.3	60.0		
A S T M distillation, °F								
1.8 P	94	312	285	415	108	100		42,500
F.3 P	385	584	393	621	368	392		50,400
10%	138	344	304	431	185	161		54,300
20%	162	360	309	438	242	200		
30%	225	413	329	459	348	276		
80%	283	469	354	504	441	334		
90%	328	504	366	540	480	360		11-63 lb
T B P distillation, °F								
1%		237		360				
5%		277		385				
10%		306		400	135			
20%		343		418	213			
30%		418		457	345			
80%		489			456			

DISTILLATION IN THE REFINING OF PETROLEUM

1617

Operating Data on Fig 42

Note—Tubular heaters and stripping plates of first two towers heated by circulated oil

Products	1		2		3		4		Charge	1+2 Combined gasoline	B Th U per bbl charge
	Atm ohd	Atm hms	First vac, ohd	First vac hms	Second vac ohd	Second vac hms	Final hms	Final hms			
Yield, % by vol	44.5	52.8	28.0	24.8	3.3	21.5	21.5	100.0	72.5	Heat input exchangers heater and circulating oil	10,000
Gravity, °API	64.7	41.2	47.9	35.5	40.6	34.7	34.7	51.4	51.4		54,300
A S T M distillation, °F										Total heat to charge Heat to cooling water	62,600
I B P	106	309	276	414	366	428	108	104	104		18,640
F B P	383	375	418	421	464	432	535	402	402		
10%	152	333	307	429	379	441	188	174	174		
20%	177	349	315	436	384	448	234	213	213		
50%	230	394	334	459	396	470	328	281	281		
80%	286	452	361	500	414	510	429	339	339		
90%	325	488	376	536	427	547	490	362	362		
T B P distillation, °F											
1%		255	241	363		375					
5%		280	218	385		399					
10%	94	299	277	403		414					
20%	140	330	297	425		430					
50%	217	395	340	451		462					
80%	288	460	379	497		514					
90%	325										

Operating Data on Fig 43

Products	1		2		B Th U per bbl charge
	Naphtha	Light stock			
% by vol	70	30			Heat input, exchangers steam heaters
A S T M distillation	°F				14,200 39,700
I B P	185				Total heat to charge
F B P	315				53,900
10%	225				Heat to cooling water
20%	235				49,400
50%	249				Distillation steam, per bbl charge
80%	269				15.4 lb
90%	281				
O C flash, °F		525			
Moisture %		<0.002			

Operating Data on Fig 44

Products	1		2		Charge brl stk solution	B Th U per bbl charge
	Naphtha	Brl stk				
Yield, % by vol	64.2	35.8	100.0		Heat to exchangers " " heater	33,400
Gravity, °API	60.5	26.9	46.6			51,800
A S T M distillation, °F					Total heat to charge	85,200
I B P	200				Heat to cooling water	67,000
F B P	341				Total distillation steam, per bbl charge	21.8 lb
5%	221					
10%	230					
20%	237					
50%	250					
80%	269					
90%	287					
S U vis at 210° F			159			
O C flash °F			560			

Operating Data on Fig 45

Products	1		2		3		Charge pressed distillate	B Th U per bbl charge
	Gas oil	Non-viscous neutral	Non-viscous neutral	Viscous neutral	Viscous neutral	Viscous neutral		
Yield, % by vol	15.2	68.9	15.9	100.0			Heat to exchangers " " heater	43,600
Gravity, °API	39.8	33.3	30.9	34.2				100,000
Distillation, °F	A S T M	T B P	T B P	T B P			Total heat to charge	143,000
I B P	215	593	720	320			Heat to cooling water	137,600
1%		338	653	748			Total distillation steam, per bbl charge	40.1 lb
5%		414	692	762				
10%		512	700	778				
20%		607	722	810				
50%		658	757	767				
80%		687	776	794				
90%		41	81	188	74			
S U vis. at 100° F				368	440			
O C flash °F								

REFERENCES

- 1 BEALE, E S L., and DOCKSEY, P *J I P T* 12, 860 (1935)
- 2 BRANDT, D G *Oil and Gas J* 27, no 19, 128 (1928)
- 3 BURCH *Proc Roy Soc (London)*, 123, 271 (1929)
- 4 BURDICK, G F., and WOODS, F H *Refiner and Nat Gas Manufacturer*, 12, no 9, 344 (1933)
- 5 CAROTHERS, W H., HILL, J W., KIRBY, J E., and JACOBSON R A *J A C S* 52, 5279 (1930)
- 6 DOBRECU, STEFAN *Refiner*, 12, no 7, 266 (1933)
- 7 DUNKEL, Z *Physik Chem* 138, 42 (1928)
- 8 GARMAN, REED W *Petr World*, 32, no 3, 38 (1935)
- 9 GOOD, A J., and CONNELL, A J *Refiner*, 12, 56 (1933)
- 10 HOWARD, F A., and LOOMIS, N E *API Bull* 9, no 7, 157 (1928)
- 11 KATZ, D L., and BROWN, G G *Ind Eng Chem* 25, 1373 (1933)
- 12 LANE, E C., and GARTON, E L. U S Bureau of Mines, R I 3279 (Sept 1935)
- 13 LEBLIE, E H., and GOOD, A J *Ind Eng Chem* 19, 453 (1927)
- 14 McCARE, W L., and THIELLE, E W *Ind Eng Chem* 17, 605 (1925)
- 15 ARTHUR G McKEE & Co *Nat Petr News*, 23, no 49, 33 (1931)
- 16 MURRAY, W J *Ind Eng Chem* 21, 917 (1929)
- 17 NELSON, W L., and SOUDERS, JR, W *Petr Eng*, 3, 131 (1931)
- 18 OBRVADCHAKOFF, S N *Ind Eng Chem* 24, 1155 (1932)
- 19 PERDREW, W E *Nat Petr News*, 21, no 44, 83 (1929)
- 20 PETERKIN, A G., JR. *Oil and Gas J* 26, no 33, 64 (1928)
- 21 PETERS, W A., JR. *Ind Eng Chem* 14, 476 (1922)
- 22 PETERS, W A., JR., and OBRVADCHAKOFF, S N *Neft Khoz* 24, no 1, 50 (1933)
- 23 PROOMOV, R S and BEISWENGER *API Bull* 10, no 2, 52 (1929)
- 24 PRIMROSE, JOHN *Refiner*, 10, no 3, 69 (1931)
- 25 UNDERWOOD, A J V *Trans Inst Ch Engrs (London)*, 10, 112 (1932)
- 26 VORACH, A C *API Bull* 10, Section II, Proceedings of 9th Annual Meeting 1928
- 27 WASHBURN, EDWARD W A P I Meeting, 26 Oct 1933
- 28 WATSON, K M., NELSON, E F., and MURPHY, GEO B *Ind Eng Chem*, 27, no 12, 1460 (1935).
- 29 WILSON, O G *Ind Eng Chem* 20, 1363 (1928)

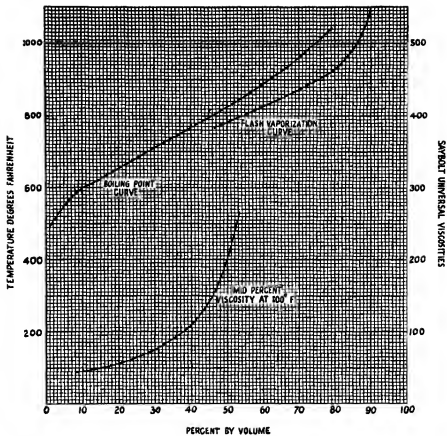

FIG 4 Reduced M-C Oklahoma City Crude Crude = 37.9° API Reduced crude = 26.7° API, 52.4% on the crude (Data from Laboratory of E. B. Badger & Sons Co)

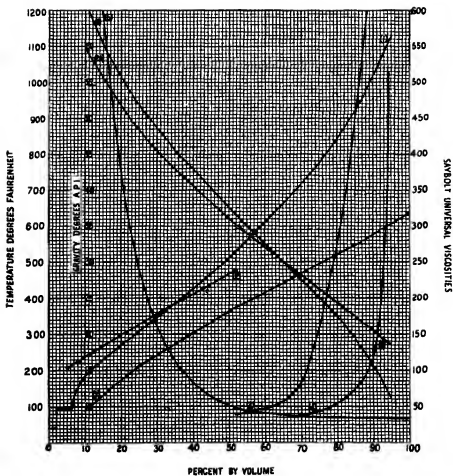

FIG 5 Properties of Iranian Crude (Data from the Laboratory of the Anglo-Iranian Oil Company)

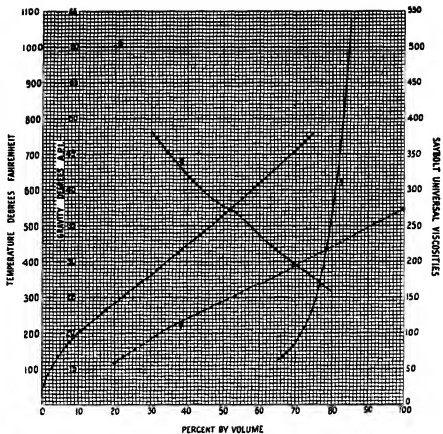

FIG 6 Mexia Crude 37° API
(From Laboratory of Standard Oil Company of New Jersey)

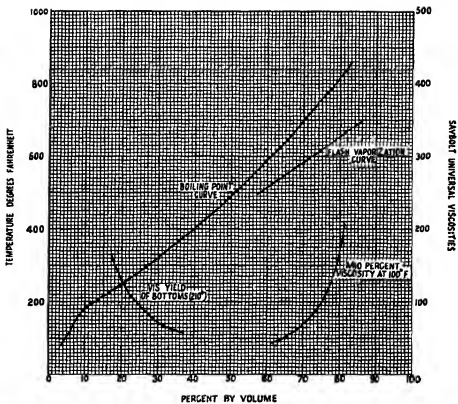

FIG 7 Penna Bradford Crude 44° API Bradford Refining Company.
(Data from Laboratory of E B Badger & Sons Co)

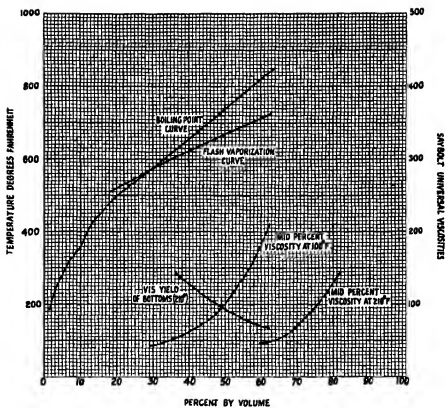

Fig 8 Franklin (Penna) Crude 31.5° API Franklin Creek Refining Company
(Data from Laboratory of E. B. Badger & Sons Co.)

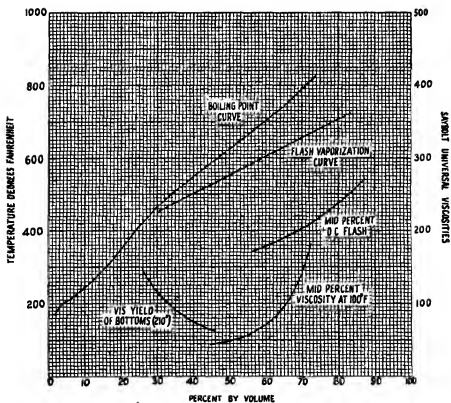

Fig 9 Cochran (Penna) Crude 37.6° API Franklin Creek Refining Company
(Data from Laboratory of E. B. Badger & Sons Co.)

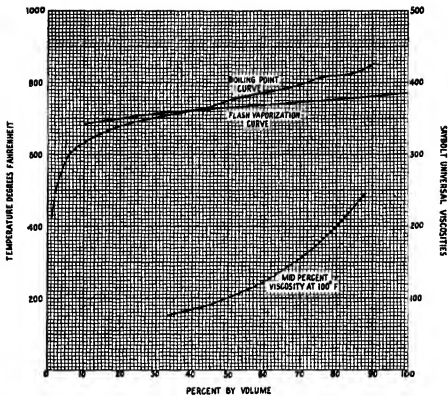

FIG 10 Pennsylvania pressed distillate 32.5° API 89.7 S U vis at 100° F McKean County Refining Company
(Data from Laboratory of E. B. Badger & Sons Co)

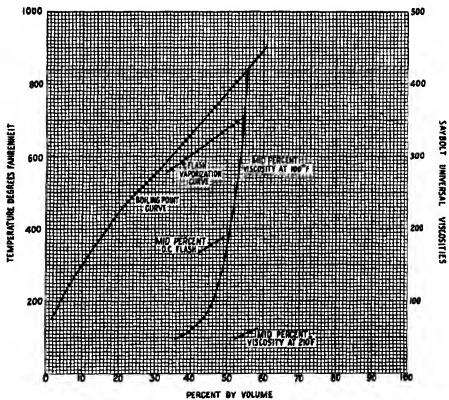

FIG 11 Healdton Crude 25.4° API Magnolia Petroleum Company
(Data from Laboratory of E. B. Badger & Sons Co)

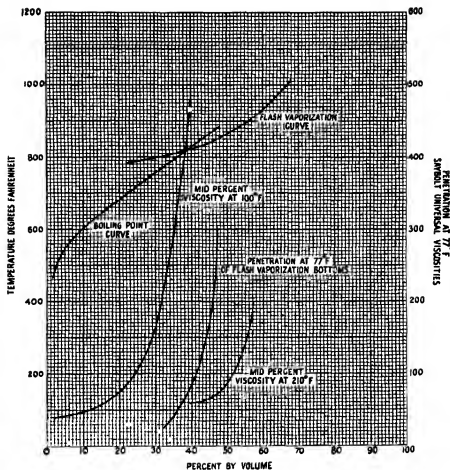

FIG 12 Reduced Healdton Crude = 25.4° API Reduced crude = 18.5° API 68.3% on the crude Magnolia Petroleum Company (Data from Laboratory of E B Badger & Sons Co)

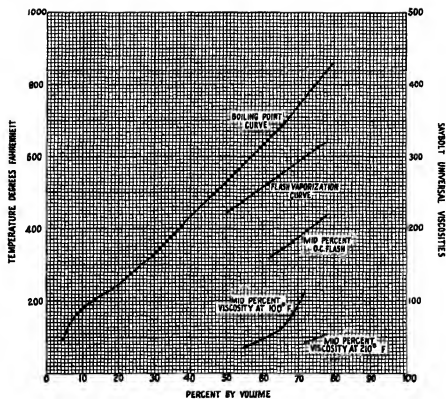

FIG 13 Rusk County Crude 37.7° API Crown Central Refining Company (Data from Laboratory of E B Badger & Sons Co)

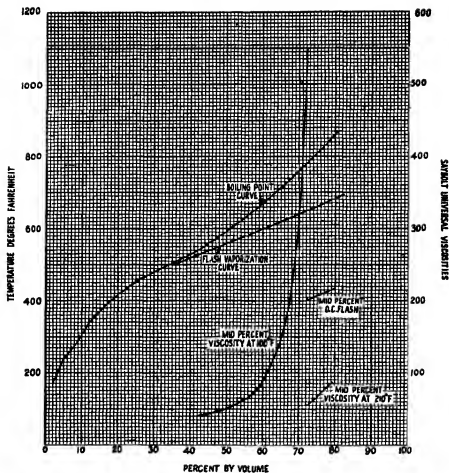

FIG 14 Sugarland Crude 27 6° API Deepwater Oil Refineries (Data from Laboratory of E B Badger & Sons Co)

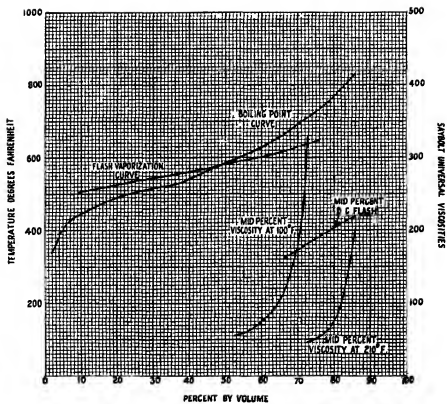

FIG 15 Miranda Crude 20 9° API Crown Central Refining Company (Data from Laboratory of E B Badger & Sons Co)

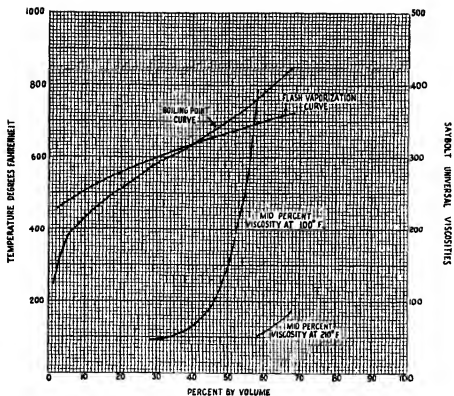

FIG 16 Oha Crude
19.7° API Tatsumi
Commercial Corp
(Data from Laboratory
of E. B. Badger
& Sons Co)

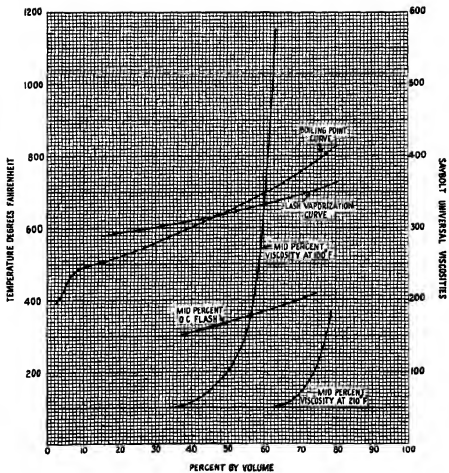

FIG 17 Mille
Crude 16.4° API
Tatsumi Commercial
Corp
(Data from Laboratory
of E. B. Badger
& Sons Co)

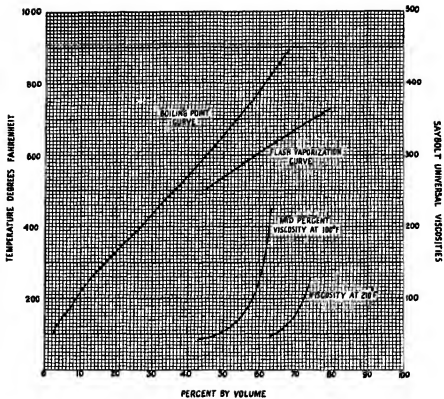

FIG 18 Pozo Rica Crude 30° API Cst Mexican "El Agula" (Data from Laboratory of E. B. Badger & Sons Co.)

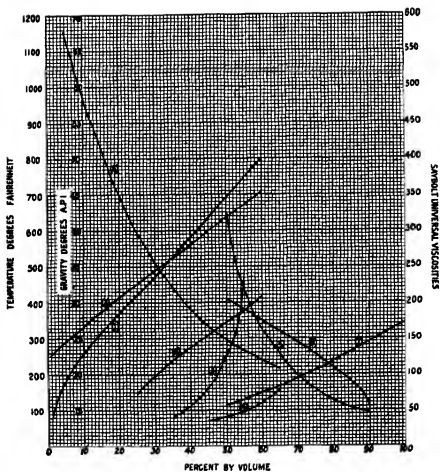

FIG 19 Colombia Crude 27° API (Data from Laboratory of Standard Oil Company of New Jersey)

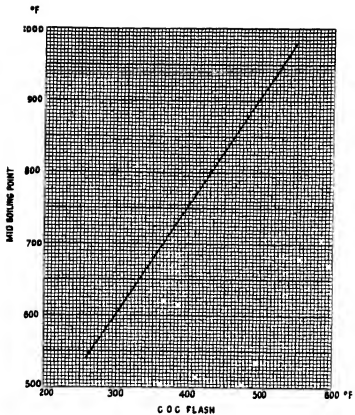

FIG 20 Relationship between Cleveland open-cup flash and mud boiling-point

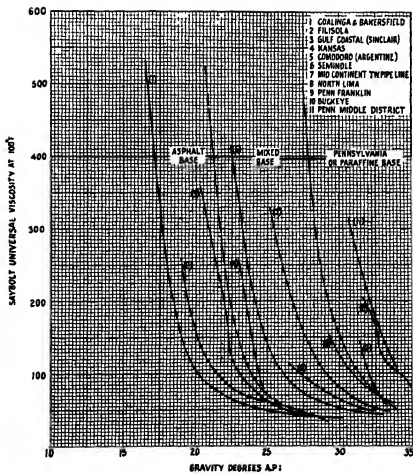

FIG 21 Relationship between A P I gravity and S U viscosity at 100° F

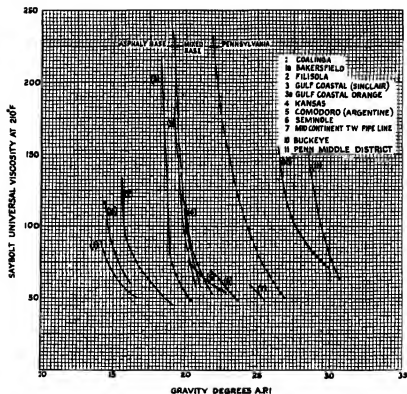

FIG 22 Relationship between A P I gravity and S U viscosity at 210° F

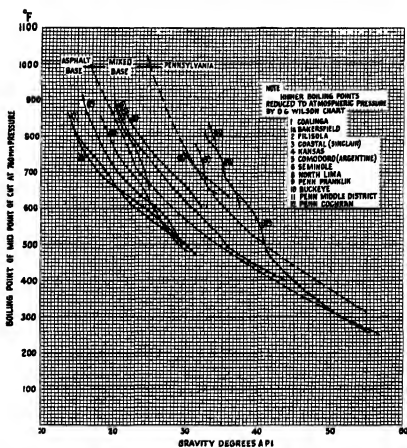

FIG 23 Relationship between A P I gravity and boiling-point of mid-point of cut at 760 mm pressure

LABORATORY AND SMALL-SCALE DISTILLATION

By MERRELL R. FENSKE, A.I.C.E.

Professor of Chemical Engineering, The Pennsylvania State College

General Principles

DISTILLATION is one of the most useful processes in petroleum refining. Through its use crude oil is rapidly and effectively separated into the common petroleum products such as gasoline, kerosene, fuel oil, lubricants, and the like. In laboratory and small-scale work, distillation serves to evaluate crudes as well as finished products, to determine optimum refining methods, and to analyze and control the various refinery operations. In research work it frequently is an important phase of any new development as well as being a very effective analytical means. Fractional distillation, in general, is the most common as well as the most effective single means for separating complicated liquid mixtures into their components or groups of components.

The understanding of the basic principles of distillation is a relatively simple matter. The vapours evolved from a liquid mixture that may be considered to be a perfect solution always contain more of the lower-boiling components than the liquid in equilibrium with these vapours. A simple means to obtain vapours in equilibrium with a liquid is to boil the liquid. In this way a partial segregation of lower-boiling materials is effected, for the vapours may be readily led to a condenser wherein they are condensed to liquid and so, in this very simple and elementary way, any portion of the liquid may be volatilized and condensed as a distillate. If the components of the liquid boil far apart, then the first portions of distillate are relatively rich in the low-boiling component, whereas if the boiling-points lie close together, the first distillates may be just perceptibly richer in the lower-boiling component. This method of generating vapours by boiling a liquid and leading the vapours directly into a condenser, wherein they are completely condensed to liquid, is conveniently termed simple distillation.

Fractional distillation differs from simple distillation in that the vapours, instead of being led directly to the condenser, first pass through some contacting or scrubbing device wherein they are intimately contacted with liquid (condensed vapour) flowing countercurrently to the vapours. At the end of this scrubbing device is the condenser in which the vapours may be partly or completely condensed to liquid, a part of this liquid being returned to the scrubbing device intimately to contact the vapours. The remainder of the liquid not delivered to the scrubbing device is the product or distillate. The liquid used to contact or scrub intimately the vapours is called reflux. The reflux ratio is expressed either as the ratio (in the same units) of liquid returned to the column to that removed as product in the same time, or as a ratio of the liquid reflux to the vapours rising. In plant usage, when equipment operation is referred to, reflux ratio denotes quantity of reflux per unit quantity of condensate. For design purposes reflux ratio is often taken as the ratio of liquid reflux to vapour at any given point in a rectifying column.

It can be shown that intimate contacting of liquid and vapour while flowing countercurrently is equivalent to a number of consecutive simple distillations. The vapours

as they pass from the still to the condenser progressively become enriched in low-boiling materials, while the liquid or reflux as it flows from condenser to still progressively increases in concentration of high-boiling components. Thus there is a gradient set up along the contacting or scrubbing section, the highest concentration of low-boiling components being at or near the condenser, and the highest concentration of high-boiling components being in the still.

Since the contacting section placed between the still and condenser may be viewed as a number of successive simple distillations, it is convenient to rate the efficiency of this section in terms of the number of perfect distillations to which it is equivalent under arbitrarily chosen operating conditions. These arbitrarily chosen conditions are usually those existing at total reflux. That is, all the vapours are completely condensed in the condenser and all the liquid so produced is introduced into the top of the fractionating column, as this scrubbing section is called, as reflux.

The more intimate the contact of vapour and liquid, or the more effective the scrubbing, under otherwise comparable conditions, the greater the concentration gradient established in the column. In other words, the column is equivalent to a larger number of simple distillations. It is clear that the most effective removal of high-boiling components from the vapour will depend on two things: (1) the physical or mechanical devices employed to bring vapour and liquid intimately together and yet allow them to flow countercurrently while affording a reasonable amount of flow of each through any given cross-sectional area, and (2) the proportion or ratio of liquid to vapour used to effect the scrubbing, for a higher proportion of liquid to vapour enables more of the high-boiling components to pass from the vapour to the refluxing liquid, since they are more soluble in the reflux liquid than the low-boiling components. In this way the high-boiling components are returned to the still, where they concentrate, leaving the vapours as they move towards the condenser to become enriched in low-boiling components.

Thus the means for contacting vapour and liquid as well as the proportion of liquid and vapour flowing countercurrently in the fractionating column are two important factors controlling the performance of a fractionating column. One without the other is usually of little value. For example, if there were present very effective contacting means but no liquid flowing countercurrently to the vapours, the result would be exactly the same as that of a simple distillation, for to have contacting means without something to contact, namely, liquid with vapour, would obviously produce no fractionation. Again, if the column were operated under total reflux, i.e. the maximum proportion of liquid to vapour was used, but with very little contacting means provided, the result would again be little more than a simple distillation. In a limiting sense this case might be conceived to be one wherein vapours passed towards the condenser in one pipe and liquid or reflux returned to the still in another. Here a high proportion of liquid to vapour is of no value because of lack of intimate contact between liquid and vapour. In general, then, careful

attention must be given to each of these factors in the successful design and operation of a fractionating column.

There are a great variety of ways for obtaining intimate contact of vapour and liquid, but only one most effective way of employing reflux. Rather than introduce the reflux at various places along the fractionating column it is best to introduce all of it (i.e. the desired quantity) at the top of the column or nearest the condenser, while causing all the vapour to be fractionated to enter the column directly from the still rather than by-pass some of the vapours and then introduce them at several points along the column. In this way vapours and liquid contact each other in maximum quantity throughout the entire length of the column. This is true for the ordinary type of laboratory fractionating apparatus consisting of a still, a fractionating column, and a condenser. In large commercial units, where there are a great many other factors than efficiency of fractionation to consider, this method may not be the most suitable. In small-scale or laboratory work it is usually a very simple matter to provide for any desired proportion of liquid issuing from the condenser to be introduced in the top of the fractionating column for reflux.

It may not be apparent how saturated vapours, which condense to liquid on the slightest cooling, are led through the fractionating column so that any reasonable proportion of those entering the column ever reach the condenser. The best plan is to make the fractionating column as nearly adiabatic as possible, for without heat flow to the surroundings the vapours cannot condense. This procedure becomes more important the greater the difference in temperature between the fractionating column and the surroundings. In the case of fractionating liquids boiling below ordinary temperatures it is again necessary to avoid heat flow between the column and the surroundings, for in this case it is the reflux liquid that would be vaporized. Maintaining a small-scale or laboratory fractionating column substantially adiabatic is not a difficult matter. It may be done by thermal insulating materials, vapour or vacuum jackets, or electrical heating means to compensate for heat flow.

The variety of methods for contacting vapours with liquid may be divided into two types. In one type of contact the vapours bubble successively through small segregated quantities of liquid arranged uniformly along the length of the fractionating column with provision for the liquid to descend and the vapours to ascend the column. The bubble-cap or plate columns belong to this type. In the other type of contact the vapours and liquid contact each other continuously throughout the column length by means of uniform packing materials which causes the liquid to break into drops or spread out into films. Contact is provided in these packings by means of the relatively extended liquid and vapour interface.

It is necessary to have some method for measuring at least the relative efficiency of the various types of contacting devices. As indicated earlier, suitable experimental conditions would be to operate the fractionating column for test purposes under total reflux. There is only one rather complete study of the efficiency of packed fractionating columns under less than total reflux [19, 1935]. Certain peculiar and anomalous results were obtained, but for the most part in the separation of relatively close boiling materials efficiencies at less than total reflux are still of the same order as those under total reflux [19, 1935]. The concept of a perfect or theoretical plate is useful in this

efficiency study. A perfect or theoretical plate is one in which the vapour (coming from the plate below) contacts the liquid on this perfect plate so completely that equilibrium between all the vapour and all the liquid is reached. In other words, as the vapour passes through the liquid on its way up the column and as the liquid descends, on a perfect or theoretical plate every molecule of liquid has had opportunity to come in contact with every molecule of vapour, so that the final distribution of molecules between the vapour and the liquid is dependent only and entirely on equilibrium or solubility relationships, and is in no way dependent on any other factors, such as time of contact, surface of contact, contact area, contacting means, and the like. Thus any fractionating column may be viewed from the basis of the number of theoretical plates to which it is equivalent, while if the efficiency of the contacting means alone is wanted, then it is very convenient to rate its efficiency as the height in centimetres or inches of packing (if a packed column) equivalent to a theoretical plate, abbreviated H E T P [28, 1922]. In the case of bubble-cap or plate columns it is convenient to express their efficiency as the ratio or percentage of theoretical plates to actual plates. Other concepts have been employed to evaluate the performance of packed columns [9, 1935, 39, 1934], but for purposes here the H E T P method is sufficient.

A mixture of two liquids is very suitable for testing fractionating columns. The preferred characteristics of the binary mixture are (1) the liquids should be obtainable in a high state of purity, (2) they should be of the same type as those regularly used in the column, (3) they should be stable and non-corrosive in the column, (4) the mixture should be capable of easy and accurate analysis, and (5) the vapour-liquid equilibrium diagram for atmospheric pressure should be available if a perfect solution is not formed. Finally, the boiling-points of the two liquids should be so chosen that under the conditions of test neither one is produced in a high state of purity. The reason for this is that, in general, the accuracy of analysis is frequently greater under these conditions. Ethylene dichloride and benzene [38, 1933], carbon tetrachloride and benzene [16, 1932], acetic acid and water [28, 1922], alcohol and water [28, 1922], benzene and toluene [41, 1935], *n*-heptane and toluene [41, 1935], *n*-heptane and methylcyclohexane [41, 1935], and methylcyclohexane and toluene [41, 1935] have been used for testing columns with good results. For petroleum work the hydrocarbon mixtures are very suitable, particularly *n*-heptane and methylcyclohexane, and methylcyclohexane and toluene. Analysis of these mixtures is quite easy and accurate by means of refractive index or density measurements [4, 1933]. Fortunately it has been found that different hydrocarbon mixtures all give substantially the same results, while this is not always true with other non-hydrocarbon mixtures having more divergent physical as well as chemical properties [41, 1935]. Thus it appears that testing a column with a binary hydrocarbon mixture would, within reasonable limits, relate its performance on all the gasoline hydrocarbons, but not necessarily those more removed from these, such as the higher-boiling petroleum non-volatile and viscous oils.

Knowing the analysis of the distillate and the still liquid under total reflux for a definite vapour velocity or rate of boiling, the number of perfect plates required to produce the observed spread in concentration is obtained from a vapour-liquid diagram of the binary mixture using the

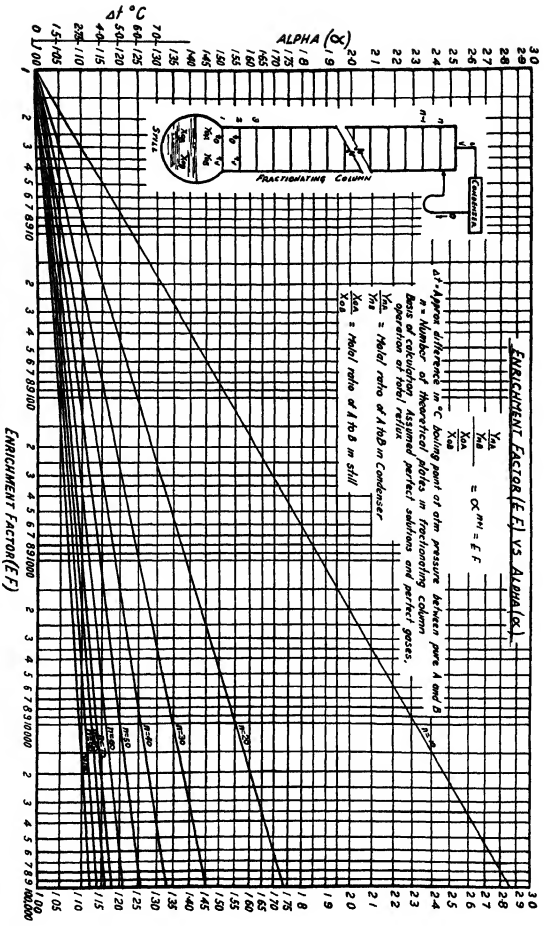

FIG. 1 The relation between enrichment, relative volatility, and number of perfect plates for operation at total reflux.

method of McCabe and Thiele [42, 1927] If the relative volatility or ratio of the vapour pressures of the two components at the same temperature is constant over the concentration range involved and perfect solutions are formed, then the equation

$$\frac{Y_{n,A}}{Y_{n,B}} = \alpha^{n+1} \frac{(X_{0,A})}{(X_{0,B})}$$

may be used to calculate the number of perfect plates required to produce the observed concentration gradient In this equation A and B represent the two components of the mixture, A being the lower boiling $Y_{n,A}/Y_{n,B}$ is the molar ratio of A to B in the distillate or condenser, while $(X_{0,A})/(X_{0,B})$ is the molar ratio in the still α is the relative volatility and n is the number of perfect plates required in the column [15, 1932] n -Heptane and methylcyclohexane form perfect solutions, and α is 1.07 at atmospheric pressure [2, 1934] Fig 1 shows for the case of perfect solutions and operation under total reflux the relationship between α , the number of perfect plates, and the enrichment produced

In order to determine the number of perfect plates in the column only, using the McCabe and Thiele method, one plate is subtracted to allow for the fact that the still liquid was analysed and not the liquid leaving the bottom of the column It is usually considered that there is one plate involved in going from the still to the column, inasmuch as the liquid in the still is boiling and the vapours rising from a boiling liquid are substantially in equilibrium with the liquid In tests of this sort a partial condenser should not be used, since the effect of the condenser would in this case be confused with that of the column A total condenser is necessary to analyse the performance of the column, and the distillate sample should be either the vapours entering the condenser or the liquid reflux to the column, it being assumed that with a total condenser these samples are of the same composition

Laboratory and small-scale fractional distillation equipment should be tested according to the method outlined here in order to know their true behaviour and performance There are so many varieties of fractional distillation apparatus that, in general, it is not possible to predict which is the more efficient or suitable Many times a more complicated apparatus is far less suitable, not only in efficiency, but also in ease of operation, than another type of apparatus that may seem too simple to be of any use Again, testing the apparatus is a very reliable method by which operators can become familiar with the best methods for using distillation apparatus Testing will quickly show in quite a convincing manner the effect of one or the other operating variables Finally, in transferring small-scale work to large-scale production it is very convenient to know and be able to give the engineering department a rather exact idea of the equipment needed to reproduce laboratory results

The following discussion is divided for convenience in presentation into the following topics (1) simple distillation, (2) fractional distillation, (3) molecular stills, and (4) other types of distillation equipment It is believed that in this way the various phases of distillation can be rather completely and yet compactly covered It is, of course, impossible to include every form of distillation apparatus that has been used Rather, it is hoped that those described here will represent typical apparatus of considerable utility in the petroleum field In case the desired apparatus

has been omitted, it is believed that those included here will offer sufficient suggestions so that any one familiar with only the simple principles of distillation will be able to realize the apparatus suitable for his particular problem

Simple Distillation

Simple distillation or a near approach to it is used considerably in specifications for petroleum products where general or overall volatility characteristics of a product are needed, for it meets many of the requirements of a simple evaporation test In a great proportion of petroleum products there are volatility specifications

Atmospheric. The Engler and ASTM [1, 1934] distillations for gasoline and naphthas, while not exact examples of simple distillation, are close approaches to it They are so well known that only mention of them suffices here However, as specifications become more exact it is altogether likely that the Engler and ASTM distillations will not be suitable, since these were never intended nor designed for more exact work Less importance is at present placed on the initial boiling-point in the ASTM apparatus, and pure substances of no boiling-point spread will give a boiling-range on the ASTM apparatus While it is not likely that in specification tests alone there will be any change from the ASTM distillation method because of its widespread use and familiarity throughout the industry, it is probable that in connexion with research work and new developments that some more exact apparatus will be needed for boiling-point and volatility measurements

The apparatus shown in Fig 2 enables true boiling-points to be obtained to within 0.1°C [34, 1934] In principle it resembles the Cottrell boiling-point apparatus [11, 1919] It can be built to handle as little as 5 cc of liquid, that shown in the figure uses 50 cc of liquid The inside glass tube is not sealed to the 48-mm flask it merely rests on the sides near the bottom as shown Boiling takes place in the annular space between the 7-mm and 13-mm tubes The heating area is rather large so as to reduce the possibility of superheating Vapour and liquid in intimate contact rise in the annular space between the innermost 13-mm and 22-mm tubes Both these tubes are open at the top as well as the bottom Vapour and liquid then escape at the top of the 22-mm tube and impinge on the thermocouple or thermometer The thorough mixing of liquid and vapour, as well as the rather high rate of boiling, ensures that true vapour-liquid equilibrium is reached without superheating as well as enabling ample quantities of liquid and vapour to contact the thermocouple, so that a true temperature is obtained with a minimum of effects of heat loss to the surroundings Above the top of the 22-mm inside tube the vapours and liquid separate, the vapours passing up to the condenser to be condensed The ring just below the condenser enables any suitable quantity of distillate to be withdrawn into the receiver This construction, together with the dimensions shown, gives a very small liquid hold-up This enables a good initial boiling-point to be obtained

Part of the liquid bubbling out of the top of the 22-mm tube falls down over the outside of this tube and into the main body of liquid in the rounded flask Part also descends the inside of the inner 13-mm tube and the inside of the 7-mm tube, where it escapes from the lower end of this tube The vapours ascending around the outside of the 7-mm tube circulates liquid down through the 7-mm tube and up around the heater

Liquid enters the 7-mm tube through the connecting tube or hole which joins the inside 13-mm and 22-mm tubes. This is the only point holding these tubes together. This hole connects the main body of liquid in the flask with the

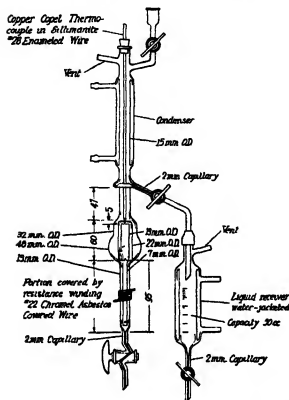

Note—All dimensions in mm
Dotted lines show wall thickness

FIG 2 Apparatus for accurate boiling-point measurements

inside of the 7-mm tube. In this way there is a steady circulation of the main body of liquid past the heating section. The small notch in the bottom of the 22-mm tube enables the main body of liquid to be withdrawn through the lower stopcock.

In operation the stopcock on the side arm is closed and heat is applied by means of the electrical resistance winding. The initial boiling-point is indicated when the thermocouple or thermometer attains a constant reading. The stopcock in the side arm may then be opened and any suitable proportion distilled off, after which it is again closed and the boiling-point read. Usually the stopcock may remain open and temperatures be recorded as the distillation proceeds. The apparatus has been found to give accurate boiling-points to temperatures higher than 200° C. With or without the side arm it is a very convenient way in which to measure vapour pressures, since any suitable pressure may be applied to the vent tube and the boiling-point under this pressure readily determined. For higher pressures (up to 10 atm.) in glass the condenser should not be sealed on as shown, but slipped on and held by rubber tubing. In this way there are no weakening joints or complicated glass seals.

Vacuum. Just as in atmospheric pressure distillations, there is a variety of simple vacuum distillations in use ranging from a simple distilling flask or Clausen flask with a side tube leading into a condenser to much more involved

pieces of equipment [44, 1935]. In petroleum the use is principally confined to volatility measurements of non-viscous as well as viscous oils. In so far as this equipment gives the desired facts its use is justified. However, it is not believed justifiable to attempt to add improvements and more involved standardizations to these devices without a careful analysis of the problems of simple distillation in vacuo.

The problems are more complicated than atmospheric distillation. The first problem is one of a suitable low pressure and its maintenance. Various manometers or manostats employing mercury or sulphuric acid have been developed for maintaining pressures at a few millimetres of mercury [14, 1932, 20, 1933, 27, 1935]. The next problem is to ensure that the vapours at the point where the temperature is measured are really at the observed pressure. This is the principal objection to most forms of apparatus in common use. The vapours from the distilling flask are led past the thermometer and then usually through one or more bends in rather small-diameter tubing and into a condenser, at the exit end of which, or even beyond this, is the connexion for the pressure measurement. There is no way of knowing what the pressure drop is from the thermometer to the point of pressure measurement. It is apt to be considerable, particularly at the lower pressures [21, 1932]. The best plan is to avoid bends and to make the tubing through which the vapours must pass as large as conveniently possible, rather than attempt to set up a rather elaborate standardization of the apparatus so as to make it give reproducible results.

There appears to be a real need and place for a simple and accurate distillation method for petroleum oils, for volatility specifications are becoming important. A variety of pressures have been used. It would seem very suitable to standardize on a given pressure, and 1 mm of mercury absolute pressure appears adequate for even rather viscous oils. In so far as possible the temperature observed should be the equilibrium point between vapour and liquid at this pressure.

The apparatus shown in Fig 3 is one of the best known for accomplishing this result. It has been in successful use for some time [29]. It is very similar to that shown in Fig 2. The heating element is internal rather than external. However, no great sacrifice of an extensive heating area has been made, for in this case the heating element is electrical resistance ribbon folded so that it consists of a large number of hollow triangles grouped together about the centre, but not touching each other, and extending out radially from the centre tube. In the apparatus shown here there is approximately 7 ft of resistance ribbon $\frac{1}{4}$ in wide, having a resistance of about 0.8 ohm per ft. Boiling occurs on the extensive surface of this ribbon. Referring to Fig 3, the vapours along with liquid rise through annular space *H* and up around tube *F*. Vapour and liquid then escape out of the top of tube *E* and impinge on the thermocouple *I*. In the space around the top of tube *E* the vapour and liquid are separated, the vapours passing up tube *C* to condenser *D*. Tube *J* is merely a tube with rings or baffles to deflect some of the vapours on to the cold condenser walls without affording any material resistance to flow and therefore pressure drop in the vapours. Liquid from the condenser runs down the walls of tube *C*, a portion or all of it collecting in the ring *K*, from which it can be withdrawn through the stopcock into the receiver *N*. It is the liquid that is led through small irregular paths rather than the vapour as in the case of most apparatus for this work.

The liquid is somewhat cooled when it reaches the stopcock leading from the ring *K*, and no trouble with the stopcock leaking has occurred. Even if it does, it in no way jeopardizes the temperature reading as long as the pressure remains 1 mm., for the vapours passing the thermocouple tip are saturated vapours. Any leaks above this point will not change the temperature as long as the pressure is unchanged.

Part of the liquid disengaged at the top of tube *E* flows down over the outside of this tube, and mixes with the

A means for controlling the pressure has been invented and is shown in Fig. 4. The complete assembly is also shown. Instead of some sort of a manometer controlling the pressure at 1 mm., the pressure is regulated by controlling the temperature on a narrow boiling or constant boiling liquid. At low pressures, \pm c of the order of 1 mm. mercury, the boiling-point of a liquid changes quite rapidly with a change in pressure. This shows that in order to control pressure, the control of temperature on a boiling liquid would be an exceptionally responsive method. This

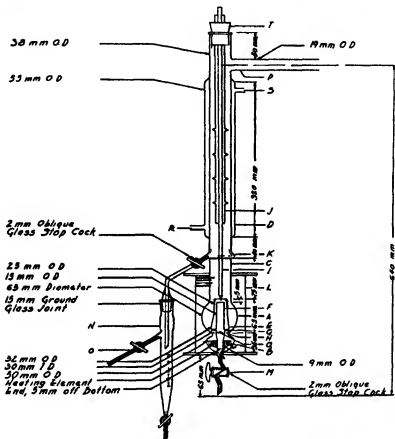

FIG. 3 Apparatus for measuring true boiling-points at reduced pressures

main part of the liquid in flask *A*, while part flows down the inside of tube *F* open at the top and bottom. This liquid as well as that from flask *A* by flowing in through tubes or holes *G* flows out at the bottom of tube *F* and up around the heater *B*, where part of it is vaporized. This affords very good circulation of the main part of the liquid past the heating surface. Tubes *E* and *F* are joined only by tubes *G*. There is no other point of contact. The assembly of tubes *E* and *F* merely rests on the lower part of flask *A* along the line *H*. A notch *Q* in the lower flared part of tube *E* permits liquid in the flask *A* to flow readily downwards when the apparatus is being drained through *M*.

Vacuum is applied at tubes *O* and *P*, while cooling medium, water or air, flows in at *R* and out at *S*. The rest of the operation is the same as that described in connexion with Fig. 2. The apparatus shown here holds 50 c.c. of oil. The glass jacket *L* is wound with resistance wire, and a thermometer placed in the air space between *A* and *L* affords means to compensate for some of the heat loss in working with high-boiling oils.

apparatus is shown at (1) in Fig. 4 [29]. The apparatus is made by sealing a 150-c.c. beaker to a length of tubing as shown. The flat bottom of the beaker is heated by an external electric heater, and affords a large heating area, thereby reducing superheating. A short length of glass tubing about 3 cm. in diameter rests on the bottom and is held centrally by small glass lugs attached thereto. This serves to conduct a good portion of the vapours over the thermocouple, while the vapours passing around the outside of the ring serve to protect the thermocouple from heat loss which is not excessive, since with diphenylmethane boiling at 1 mm. the temperature is about 80° C. The rate of heating is so adjusted that the liquid barely boils. Some 6-mm to 8-mm glass Raschig rings are placed in the bottom and about 5 c.c. of diphenylmethane or any other stable uniformly boiling liquid is added to the apparatus. The water condenser condenses the vapours completely and the liquid is returned to the heated flask. A very small change in pressure will cause sufficient change in temperature of the boiling liquid so that any sensitive temperature-

response device, such as a thermocouple or series of thermocouples, may be used and will control the pressure at 1 mm of mercury to within ± 0.01 mm of mercury over long periods of time [29]

by the thermocouples *Q* again becomes less so as to shift the light beam off the photo tube. This device is quite simple to build, can be made of any suitable sensitivity, and has a short period of oscillation so that it is quick to

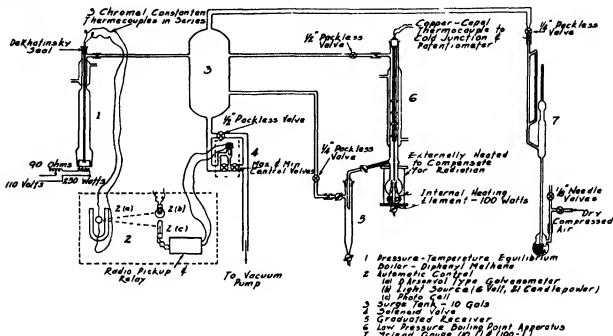

FIG 4 Pressure control and assembly of low-pressure boiling-point apparatus

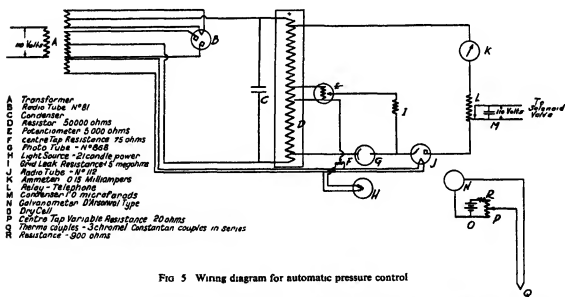

FIG 5 Wiring diagram for automatic pressure control

An ordinary thermocouple temperature controller has been used to actuate the solenoid valve (4) in Fig 4 instead of the vacuum tube assembly shown in Fig 5. However, the assembly in Fig 5 is cheaper to construct and with an ordinary sensitive galvanometer, which is operated by the thermocouple, the control is very close. In this case there is a small stop attached to the mirror of the D'Arsonval galvanometer so that the light beam from the light *H* in Fig. 5 is held on the photo tube *G* until the e m f generated

respond to temperature changes at the thermocouple *Q*. These couples are placed in apparatus 1 of Fig 4.

Another form of distillation apparatus for distilling lubricating oils at 1 mm mercury pressure is shown in Fig 6 [29]. This apparatus is used for analysing the blending of oils. The heater is external, consisting of an electrically heated aluminium casting which surrounds the flask. This type of heater for vacuum distillation has been found very suitable, for there is little tendency for bumping

or violent boiling of the liquid in the flask and the rate of distillation can be held constant or otherwise standardized very easily. The two-section distillate receiver enables the first portion, or light distillate, to be segregated from the

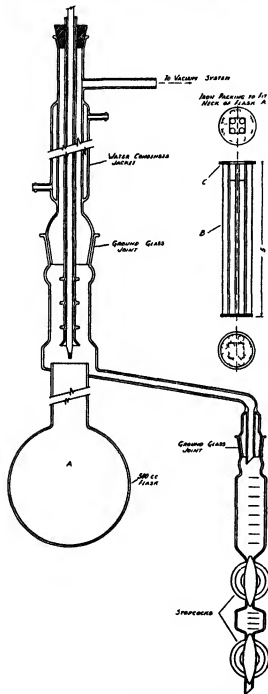

FIG. 6 Vacuum distillation apparatus

remainder of the distillate, so permitting certain inspection data to be obtained on it.

In order to produce a certain amount of reflux in a standardized way the bundle of iron rods shown at *B* is inserted into the neck of the flask at *A*, being held and supported by the lip *C*. This section has no source of heat other than the vapours passing over and through it. It is designed so as to permit ample contact with vapours while

affording the minimum of pressure drop as the vapours pass through. The temperature of this section always lags behind the temperature of the vapours, since it has a certain heat capacity which is standardized, and its only heat source is from the vapours. Some condensation of the vapours therefore occurs, thus producing a certain unknown but standardized amount of reflux so that the results are always reproducible. This rectification is usually sufficient to define more clearly the character of the light distillates used in preparing oil blends.

Fractional Distillation

There are three essential parts to a piece of fractional distillation equipment. They are the still, the fractionation column, and the condenser.

The still supplies to the column vapours of the material to be fractionated, and boils the liquid reflux from the column. Therefore in the still heat must be transferred from some heat source to the boiling liquid. In batch distillations it also serves as the container for the material to be fractionated. In this case care must be exercised, particularly in the fractional distillation of a large quantity of liquid, that the reflux from the column mixes completely with the contents of the still, and that the vapours generated in the still are those generated from or in equilibrium with all the liquid in the still. It is sometimes possible, in working with large quantities of liquid, that the reflux liquid or only a part of the contents of the still are subjected to boiling. By a little more careful and thoughtful design of the still and heating section, it is easily possible to have ample mixing and circulation of all the liquid in the still as well as to have mixing with the reflux liquid, and in addition to have the vapours entering the column in substantial equilibrium with all the liquid in the still.

In the usual type of batch fractional distillation the high-boiling components of the mixture being fractionated are subjected to heating for a relatively long time at increasing temperatures. Care should be taken, then, to avoid as much as possible any chemical changes or decomposition by the increased temperatures. In many cases the same amount of heat needs to be added to the still when the components are high boiling as when they are low boiling. With other things remaining the same, the heat flow is proportional to the heating area and to the temperature difference between the heating surface and the boiling liquid. It follows that it is highly desirable to use as large a heating area as possible, enabling the heating surface to be at the lowest possible temperatures, so avoiding chemical changes in the boiling liquid due to excessive temperatures. It is also desirable, when the distillation time is apt to be long and the temperatures high, to design the still so that as the quantity of liquid in it decreases the heating area remains large. In some cases, as when heating the sides of a still, the heating area is large when the still is full, but as it becomes empty the effective heating area is reduced, and to maintain the same heat flow it follows that the temperature of the heating surface must increase. The material in the still may not be able to withstand this extra increment of temperature without decomposition or other chemical changes.

The vapours should be generated in the still so that they enter the column in a steady uniform stream rather than in a pulsating manner. A uniform flow of vapours to the column enables a smoother and more uniform column performance.

In laboratory and small-scale work electric heating of

apparatus is, therefore, a sort of heat engine, heat is supplied at one temperature level, that of the boiling liquid in the still, and is removed or flows out at another lower temperature level, that of the condensing vapours in the condenser. In this way it is possible to produce work, but in a fractionating apparatus this work is used to effect the separation of the components of a mixture, since this requires work. A fractionating apparatus is, then, a rather

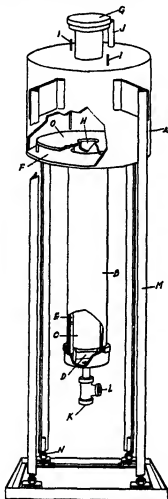

FIG 8 Still for gasoline distillation

unique piece of equipment in which work is produced by heat flowing from a higher to a lower temperature, but this work is consumed in the same apparatus and at the same time so as to cause a separation of the mixture being fractionated. If there is no temperature difference, then there is no work done and consequently no separation is possible. This is another way of saying that with a constant boiling liquid, either a mixture or a single substance, no separation is possible by distillation means.

There are two general types of condensers that may be used, namely, a total condenser and a partial condenser. In a total condenser all the vapours entering it are completely or totally condensed to liquid, a part of this liquid or a part of the vapours entering the condenser is withdrawn as the product or distillate, the remainder is returned to the top of the fractionating column as reflux liquid. In a partial condenser only a part of the vapours are condensed to liquid, this part being that required for reflux. The

remainder of the vapours escape, usually at the opposite end of the condenser, and are then led to a total condenser where they are completely condensed to become the product or distillate. By this means it is possible to get further enrichment of the vapours in low-boiling materials, or to effect further fractionation. This extra degree of fractionation may be considerable or small, depending on the construction and operation of the partial condenser.

A partial condenser is convenient where there is a wide difference in boiling-points of the materials entering it. Given a reasonably efficient column, this may happen when some of the materials are low-boiling or non-condensable at the temperature of the condenser. A partial condenser is a very effective way to segregate these materials. Again, a partial condenser can be operated to increase materially the sharpness of separation between fractions, for at this point, namely, when one component has been practically completely eliminated and the next higher boiling component is beginning to work its way up the column, the vapours entering the condenser may consist of materials of considerable difference in boiling-point despite the efficiency of the column. The partial condenser may be operated to reduce the size of this intermediate fraction. In general, the operation of a partial condenser requires constant attention, since it is to a certain degree accomplishing fractionation as well as controlling the reflux ratio to the column below it. Variation in the reflux ratio in the column usually produces vapours of a different composition entering the condenser, and the condenser operation must be changed accordingly. The operation of the condenser is usually varied by changing the heat that it picks up, or its effective cooling. Frequently this is done by changing the amount of cooling medium passing through it, it may also be accomplished by varying the surface available for cooling. These methods allow any suitable quantity of vapour to be condensed for reflux while permitting the desired quantity for product to pass through unchanged.

The simplest operation is with a total condenser, and in the majority of cases the condenser is operated as a total condenser. If a general increased degree of separation is desired, it is usually better practice and more convenient to attain this increased degree of separation either by designing the fractionating column to be more efficient or by adding to its length.

The Fractionating Column. General Features

Frequently a fractionating apparatus must be used for analytical purposes. That is, a given mixture may not be capable of analysis by chemical or other means, but may be composed of materials which are separable by physical means, for example, by efficient distillation. In these cases it is very important to have an efficient fractionating column and to operate it efficiently. Other things being equal, the column will produce the greatest change in concentration of a given component between the still and the condenser the more perfect plates it contains or is equivalent to, and the higher the reflux ratio used. Since for analytical purposes the fractionating apparatus is frequently small, some form of packed fractionating column is in widespread use in these cases.

The nature of the packing and the length of the column are the principal factors determining the number of theoretical plates to which the column is equivalent when it is operated adiabatically. In some cases, rather than use a uniform length of tubing containing packing material,



FIG 10 Packing materials for laboratory fractionating columns

- | | |
|---|-------------------------------|
| 1 No 16 double-link brass jack chain | 9 No 2 cut tack |
| 2 No 16 single-link iron jack chain | 10 Hollow square wire form |
| 3 No 19 single-link aluminum jack chain | 11 Double-cross wire form |
| 4 One-turn metal helix | 12 Bifurcated cross |
| 5 Two-turn metal helix | 13 Glass tube |
| 6 Six-turn metal helix | 14 Glass ring |
| 7 Straight carding tooth | 15 No 1 holei-Vanderhoef ring |
| 8 Bent carding tooth | |

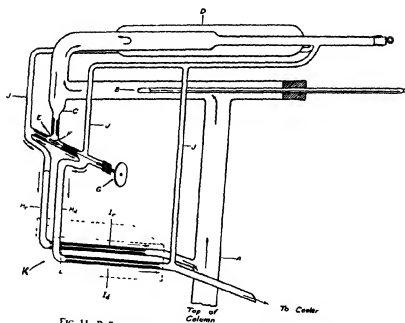

FIG 11 RFLux regulator for laboratory fractionating columns

the fractionating column consists of a length of tubing which has been shaped in various ways, examples being shown in Fig 9. However, experience has now shown that in general a more efficient column results by using a length of uniform tubing and proper packing materials

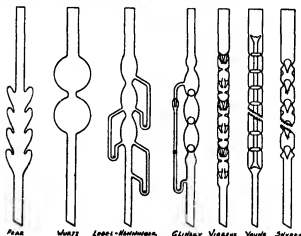

FIG 9 Various types of fractionating columns

The choice of the proper packing material for small-size fractionating columns depends on a number of factors, some of which are (1) pressure drop through the packing, (2) liquid hold-up on the packing, (3) height equivalent to a theoretical plate, H E T P, (4) maximum rate of vapour and liquid counterflow without flooding, (5) mechanical strength, (6) tendency to corrode, and (7) ease of fabrication. A few comments on each of these factors follow. For the most part, pressure drop is only important in vacuum fractionations. Since the principal purpose for employing vacuum is to vaporize materials without thermal decomposition, and the highest temperatures in the usual fractionation apparatus are in the still, the pressure in the still must be low. This obviously cannot be realized if there is a high-pressure drop or resistance to flow of the vapours through the packing, even if the pressure at the top of the column is kept very low.

The liquid hold-up on the packing is related to the size or proportion of the intermediate fractions produced in batch fractionations. For example, if a simple binary mixture of *A* and *B* were being fractionated and the separation such that it were possible to produce a quantity of substantially pure *A* as well as *B*, the size of the intermediate fraction, or that material resulting when the last amounts of *A* were being obtained as distillate along with the first amounts of *B*, would be dependent on the hold-up of liquid in the column, for the lower the hold-up the smaller it would be possible to make the intermediate fraction. The exact relationship between intermediate fraction volume and liquid hold-up in a column is a complicated one. It is of such a magnitude that the effect can be readily observed in changing from plate to packed columns for batch fractionations, and it also is a factor varying with the type of packing in the columns. If the hold-up of a given column is too high so that it is interfering with the sharpness of separation, the size of the liquid sample charged into the still might be increased, thus making the intermediate fraction a smaller percentage of the total distillate. A packing of low hold-up and yet high efficiency is desirable. There is little quantitative published data on this factor. The hold-up of packing materials in a static way

has been reported [15, 1932, 30, 1933]. This consists in wetting the packing with a known volume of liquid and determining how much adheres after certain arbitrarily chosen drainage times. While these results perhaps permit comparisons, it is doubtful whether they are significant for further more exact analysis of this factor. Recently it has been shown [41, 1935] that the true hold-up of liquid in a fractionation column can be obtained rather simply. This hold-up is that which exists when the column is in operation and may be variable with the rate of liquid flow through the column. The method consists in adding a definite amount of a soluble non-volatile substance to a definite amount of liquid charged to the dry still and column. When the desired operating conditions are reached while operating under total reflux, a known volume of the liquid in the still is withdrawn. The liquid is then evaporated, leaving the non-volatile material, which is weighed accurately on an analytical balance. Knowing the amount of liquid in the still associated with the total amount of non-volatile substance at the start and at the point of test, the liquid retained in the column is readily determined.

The H E T P of a packing material is a fairly definite and reproducible quantity under constant test conditions. However, there are certain sources of error and variables in the determination of H E T P values. Some of these are: analysis of samples, purity of test liquids, method of obtaining samples, extent to which the column is adiabatic, measurement of distillation rate, uniformity of distillation rate, uniformity of packing in column, possible corrosion of the packing, distribution of reflux liquid from the condenser to the column, distribution of descending liquid in the column, accuracy of the vapour/liquid diagram, effect, if any, of concentration on H E T P, and establishment of equilibrium conditions. H E T P data are available on a variety of packing materials [16, 1932, 18, 1934, 28, 1922, 41, 1935]. Some typical results on packing materials shown in Fig 10 are given in Table I [18, 1934]. Generalized results show that efficient packing materials need not be of a complicated shape or structure. The packing should be of such a type that it not only will pack uniformly in a horizontal direction, but also in a vertical one, and in addition it should fit the wall of the column snugly and closely. A uniform packing in a column reduces channelling of the refluxing liquid stream to a minimum, it enables the smoothest operation of the fractionating column with greatest efficiency. It is also true that there is a range of column diameters best suited for any given size or shape of packing, and that it does not appear practical to standardize and employ one type of packing for any size whatever of column. In general, the greater the diameter of the column the less efficient the column employing the same packing material. For this reason in columns of several inches or more in diameter some form of distributor should be used to reposition and redistribute the channelled refluxing liquid stream. Again, in columns in excess of perhaps 6 ft. in height it is advisable to use some form of distributor, spacing them in the column about 6-ft. apart. Exceptions to these generalities are likely to occur in the spiral type of continuous packing used by Podbielniak [30, 1933, 31, 1933].

While bubble-plate columns are in widespread use in large-size distillation equipment, they have been used successfully in small-scale work, due largely to a rather simple design [5, 1931]. Since the plate efficiency of small bubble-plate columns is high—of the order of 90% or

better—and it is possible to get a rather close plate spacing, a considerable number of perfect plates may be realized in the space ordinarily available for a fractionating column.

The maximum rate of liquid and vapour counterflow in a column without flooding obviously determines the capacity or throughput of the column. It is desirable to have this as large as possible without sacrifice of H E T P value. The most desirable packing is one which gives the rather unusual combination of low H E T P and high throughput [18, 1934]. In general it is easy to get one of these factors, but only by sacrificing the other. In vacuum fractionation, because of the higher vapour velocity as

the column to operate under total reflux for periodic times to serve as a guide for operating the column at less than total reflux. Sometimes it is desirable to carry out fractionations in this tentative way. On the other hand, it is often more desirable to choose from experience a practical reflux ratio and carry out the entire fractionation under conditions of constant reflux ratio. This is obviously the most reproducible way, and the method likely to be of most significance if operations are to be standardized or reproduced on a larger scale.

In either way it is desirable to have some idea of the reflux ratio. There are many methods of evaluating or estimating it. A simple but less exact way is to count

TABLE I
Correlation of Packing Measurements and H E T P

Packing	Area × % free space 100	Free space %	H E T P		Condensate at flooding velocity cu in/hr (l/hr)	Dimensions of test column (in.)
			in			
Straight $\frac{1}{8}$ -in carding teeth	47.0	84.9	1.5		92 (1.5)	0.76 × 27
Straight $\frac{1}{16}$ -in carding teeth	46.2	81.6	1.7			0.76 × 27
Cramped wire	44.5	64.0				
Bent $\frac{1}{8}$ -in carding teeth	40.4	84.0	1.7		122 (2.0)	0.76 × 27
1-turn no. 24 Lucero wire helix	38.2	82.0				
Miscellaneous carding teeth	35.1	92.1	2.2			0.76 × 27
Double-cross wire form	34.0	71.9	2.2		110 (1.8)	0.76 × 27
Outside prong rivets	31.3	66.2				
2-turn and 3-turn no. 24 Lucero wire helix	30.3	86.5				
Hollow-square wire form	27.3	79.6	5.4			0.80 × 55
No. 20 single-link iron jack chain	25.0	69.5	5.2			2.0 × 53
No. 2 cut tacks	23.3	64.5	2.4		53 (0.9)	0.80 × 55
6-turn no. 24 Lucero wire helix	21.1	91.2	8.0			0.80 × 66
No. 18 single-link iron jack chain	19.9	69.4	6.5			2.0 × 53
Loosing rings	19.0	84.7				
Bifurcated rivets	17.7	54.5				
No. 3 cut tacks	17.1	68.0				
Glass tubes	15.3	69.7	5.5		73 (1.2)	0.78 × 27
No. 16 single-link iron jack chain	15.0	72.3	4.2			0.76 × 27
Bird shot	14.2	39.4				
Cholet-Vanderhoef rings	12.6	90.0				
B B shot	8.4	41.5				

feet per second, and the necessity of avoiding too high a pressure drop, it is frequently necessary to sacrifice equivalent plates for low-pressure drop or high throughput.

Questions of mechanical strength, tendency to corrode, and ease of fabrication are definite problems easily recognized. In small fractionating columns mechanical strength is usually of no particular importance even in glass. The increasing variety of new alloys continually simplifies problems of corrosion and fabrication.

The Fractionating Column. Operating Details

At the start of a small-scale batch fractional distillation it is preferable to bring the apparatus to equilibrium by operating it under steady, uniform conditions at total reflux. This sets up the concentration gradient along the column, a steady state being noticed when the thermocouple or thermometer at the top of the column attains the lowest steady unchanging value. The product may now be withdrawn, maintaining the reflux ratio high enough to give the best possible purity or the desired temperatures at the top of the column. If the product is withdrawn too rapidly, the reflux temperature will rise rapidly and, if the total reflux again be established, it will be found that the temperature drops to a value that cannot be lowered. This is the lowest temperature attainable with the particular column and mixture being fractionated. It is frequently desirable in the course of a difficult fractionation to allow

the drops of liquid returning to the column and those withdrawn as product. If the entire distillation apparatus is adiabatic, and the heating of the still is electric, it is possible to estimate the rate of boiling from the wattage input to the still and the heat of vaporization of the liquid in the apparatus. The product withdrawal in a given time is usually easily obtained by volume measurement over a time interval. Sometimes it is possible to insert a small orifice meter at the top of the column near the condenser and calibrate this to read volume of liquid flow versus liquid head above the orifice. This is conveniently used to measure the reflux to the column, the product being measured directly as a volume in a given time. One of the simplest and a fairly reliable means of estimating the reflux flow, knowing the heat of vaporization of the material being fractionated, is to measure the heat imparted to the condenser water, i.e. make a heat balance around the condenser. This involves merely measuring the condenser water flow and its inlet and outlet temperatures. On larger columns this is a particularly useful means. While the cooling water might have cooled the condensate below its boiling-point and so removed more than its heat of vaporization, this cooled condensate could hardly descend the column more than one perfect plate before it would be heated to its boiling-point by condensing vapours. Thus even though this heat balance may not give the correct results for the reflux to the top plate, it should give

column of liquid. In the glass column of Fig. 16 the vapours enter from the still, pass up through tube *B*, and down through the annular space between tube *B* and bubble cap *C*, bubble through the liquid and pass on to the next plate to repeat this operation. Liquid descending the column is led across the plate as shown, the level being maintained at *D*, and the flow down through *E*.

Fig. 17 shows a complete all-glass bubble-plate column [5, 1931]. The liquid in still 1 is boiled by electric heater 2, the vapours entering the column at 7. A glass jacket 9 is wound with electric resistance wire and serves to reduce

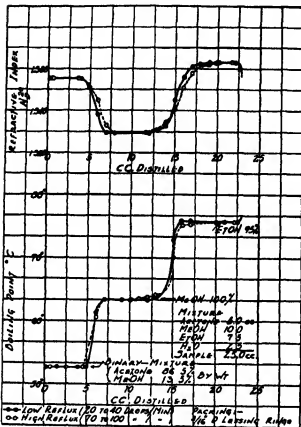

FIG 14 Fractional distillation curves for a column packed with Lessing rings

heat flow from column 6. At 10 is a liquid flow divider serving to divert any suitable amount of liquid condensed at the top condenser back to the column for reflux, and the remainder, as product, flows into the Cottrell boiling-point apparatus 11. This apparatus is very similar in function and purpose to that in Fig. 2. This enables the true boiling-points of distillates coming from the column to be continually determined. The boiling liquid from the Cottrell apparatus flows constantly through cooler 12 into receiver 13. The upper end of cooler 14 may be connected to any suitable constant pressure reservoir, maintained at either atmospheric or sub-atmospheric pressure. Columns of this sort have been used extensively for research on composition of gasoline at the National Bureau of Standards. Complete details of the construction of these columns are given in Bureau of Standards Research Paper no. 379.

Performance curves of these glass bubble-plate columns as well as a jack-chain packed column are shown in Fig. 18. The test liquid was a mixture of benzene (boiling-point

80° C.) and ethylene chloride (boiling-point 83° C.). These curves clearly show the possibility of separating very close boiling liquids by fractional distillation, provided

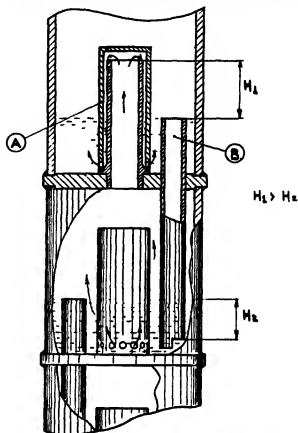

FIG 15 Section of all-metal non-sponging bubble-cap column

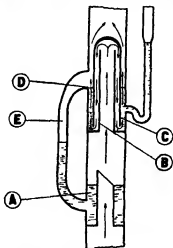

FIG 16 Explanatory diagram of glass bubble-cap column

there are sufficient perfect plates available and the reflux ratio is high enough. The diameters of the small, medium, and large columns were approximately 10-m.m., 18-m.m., and 25-m.m. (0.39-in., 0.71-in., and 1-in.) respectively.

It is possible to make a rather extensive analysis of gasolines using columns of the type shown in Figs. 19 and 20 [16, 1932, 17, 1932]. Since the amount of any one

hydrocarbon in an average straight-run gasoline is very small it is necessary, if further work is to be done on the fractions, to have fractions of reasonable size. This necessitates fractionating a rather large volume of gasoline, but there are no objections to doing so. Valuable information can be obtained by a careful fractionation of gasolines

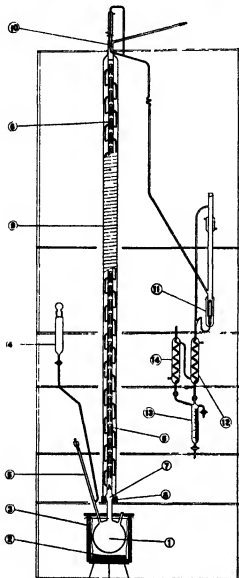

FIG 17 All-glass bubble-cap fractionating apparatus

in columns having of the order of 30 to 50 or more perfect plates. Using this number of plates with reflux ratios of about 20 to 1 or more, it is possible to make very effective progress towards reducing gasoline to a list of hydrocarbons or at least to effect a segregation of them which will prove very useful in analysing problems of possible chemical uses of gasoline, or production of special fuels, solvents, and the like.

For the primary fractionation of gasolines a column similar to Fig. 19 is useful. The still might be forty to a hundred gallons capacity, and the column for this size still about 4-in. in diameter and 40 or more feet tall. It may be packed with suitable non-corrosive packing such as glass, stoneware, or metal rings. With an apparatus of

this sort the complete fractionation of the gasoline would require from 3 to 7 days' continuous operation. It is believed that ample temperature measurements by thermocouples throughout the apparatus as well as electric heating are very much worth while. For average gasolines of low or moderate sulphur content, stainless steel and aluminum have been found to be good materials of construction. The still may ordinarily be of steel. It is not necessary to have the mica windows as shown. A little experience, and a manometer attached to the still to read the pressure drop through the column, will enable suitable and smooth

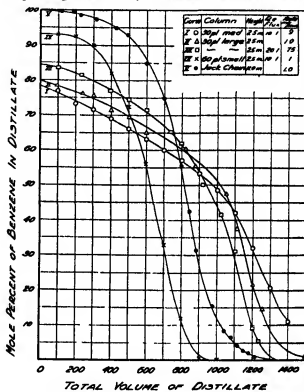

FIG 18 Fractional distillation curves of benzene-ethylene chloride mixtures

operation to be attained. Superficial vapour velocities at operating temperatures for this type of column can be of the order of 1-ft per sec. Electric heating along the column should be used as shown. This should be in at least three separate sections to enable the heating to be in accord with the temperature gradient in the column. The column in Fig. 20 is most suitable for a re-run column, i.e. one in which fractions from the larger column can be further fractionated. It should be noted in both these columns that the reflux is calculated from the heat imparted to the condenser water.

A very simple and yet efficient fractionating apparatus is shown in Fig. 21 [41, 1934]. The column is a nickel tube 33-mm (1.31-in.) outside diameter \times no. 20 Stube gauge wall thickness, and approximately 2.74-metres (9-ft.) tall. The condenser is a section of 25-mm (1-in.) Pyrex glass piping with one end flanged, the companion flange being attached to the nickel tube. This gasketed joint of Pyrex glass to metal has been found entirely satisfactory even for 3-in. diameter columns. The product is withdrawn as vapour from the column just below the condenser. The product line is a 6-mm (0.25-in.) o.d. tube brazed on to the side of the column, but does not project

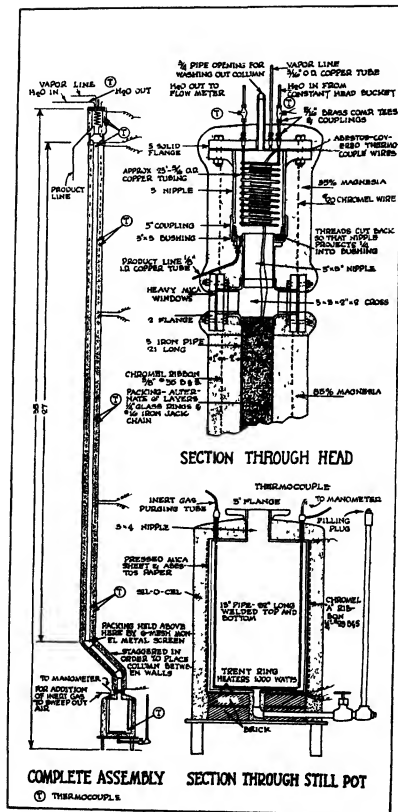

FIG 19 Equipment suitable for fractional distillation of gasoline

into it. By using three heat switches it is possible to have the minimum of external heat dissipation and power loss, while covering a wide range of wattage input to the still.

The nickel column is first covered with a 5-mm thickness of asbestos paper. Over this, asbestos-covered

duct withdrawal. It is not necessary to have any cup or collecting device on the end of the tube leading into the column, for once the tube, which is always inclined downwards, has liquid in it, the withdrawal of liquid product sucks more vapour, which is subsequently condensed, into the tube. For low-boiling materials it is best to have this product tube water jacketed.

The condenser of the form shown has been found satisfactory. By having it as close to the top of the column as possible, and the cooling water in the annular space as shown, the heat losses to the room are reduced to negligible proportions. In this way it is a simple matter to determine the amount of material being condensed per hour and so returned to the column as reflux. Thermocouples in the inlet and outlet condenser water are connected so that they read the temperature rise in the cooling water. The exit water from the condenser passes into a 500-c.c. graduated burette. Noting the time for a given amount of water to flow and the rise in its temperature, the heat picked up per minute or per hour is readily determined. For most hydrocarbons the heat of vaporization is known or may be calculated with sufficient accuracy, so that by observing the rate of product withdrawal from the column the reflux ratio is determined.

The packing material is the most important part of any column. Results on two wire-form packing materials are available for the column in Fig. 21. One form has the shape of a staple or carding tooth made from wire about 0.5-mm (0.02-in.) in diameter, the staple measuring 4 x 6-mm (0.157 x 0.23-in.). The legs of the staple are about 4-mm (0.157-in.) long, the distance between the ends of the legs being about 6-mm (0.23-in.). These staples are packed into the column at random. They have about 72% free space.

Results of testing this packing are given in Table II [41, 1934]. It is seen that the mixture of carbon tetrachloride and benzene behaves somewhat differently from hydrocarbons. As indicated in the table, a 2.74-metre (9-ft.) length of this packing is equivalent to about 35 perfect plates when tested with a mixture of *n*-heptane and methylcyclohexane at total reflux. With hydrocarbons a rate of boiling under total reflux of about 4 litres per hour is possible without flooding in this 32-mm (1.25-in.) inside diameter column.

Another packing material consisting of one-turn nickel wire helices or rings also proved efficient. This packing is made by winding no. 26 nickel wire on a 4-mm (0.156-in.) rod, and cutting each turn of the helix formed to give single rings. Such packing has about 86% free space. A 2.74-metre (9-ft.) length of this packing is equivalent to about 22 perfect plates when tested at total reflux with *n*-heptane and methylcyclohexane. A rate of boiling of about 6 litres of liquid per hour under total reflux is possible with hydrocarbons without flooding in a column 32-mm (1.25-in.) inside diameter. Data are shown in Table III [41, 1934].

Using the above one-turn rings or helices made from no. 26 gauge nickel wire wound on a 3.2-mm (0.125-in.) rod as a packing material in a 32-mm (1.25-in.) inside diameter nickel column, 12-metres (40-ft.) tall, enabled the equivalent of one hundred perfect plates to be obtained on testing with the *n*-heptane methylcyclohexane mixture. The column was operated both as a stripping and enriching column, and reproducible and consistent results were obtained. In construction the column was very similar to that shown in Fig. 21, except for the length [29].

A small, convenient, all-glass fractionation apparatus is shown in Fig. 22. The apparatus measures about 100-cm

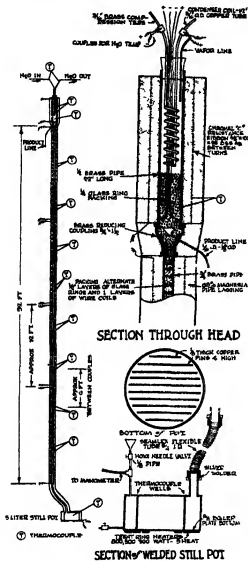

FIG. 20 Apparatus for refractonating narrow-boiling fractions

resistance wire is wound to attain the proper adiabatic operating conditions for the column. For ordinary purposes a maximum of from 50 to 100 watts per lineal foot is sufficient. Over this winding is placed standard asbestos or magnesia pipe insulation.

Asbestos-covered thermocouple wires are brazed to the column, and others brazed to copper strips about 250-mm long, 25-mm wide, and 2-mm thick, placed between the asbestos paper insulation and the heating wire. These latter couples attached to the copper plates enable average temperatures to be obtained. By adjusting the heat input to the column so that the temperature difference between the column and the copper strips is either zero or small, substantially adiabatic conditions are attained.

The product tube is fitted at the lower end with a small needle valve to permit easy adjustment of the rate of pro-

DISTILLATION

TABLE II

HETP Tests using U-Type Packing
(In nickel column, 32 mm i.d., and 2.74 meters packed section)

Run no	Velocity of liquid at top, l/hr	Pressure drop mm of Hg	Mol % more volatile component		Total theoretical plates	HETP	
			Distillate	Still		Cm	In
<i>Normal heptane and methylcyclohexane*</i>							
1	1.8	7.0	80.5	25.5	38.0	7.4	2.9
2	2.0	7.0	84.0	24.0	42.5	6.6	2.6
3	2.1	6.5	90.0	24.0	50.5	5.6	2.2
4	2.2	5.0	81.0	22.8	40.5	7.1	2.8
5	2.3	8.0	82.0	26.6	35.0	8.1	3.2
6	4.6	37.0	76.0	20.5	38.0	7.4	2.9
7	4.8	44.0	75.0	25.6	35.0	8.7	3.4
8	5.0	36.0	80.0	28.0	35.5	7.9	3.1
<i>Carbon tetrachloride and benzene†</i>							
1	1.6	10.0	76.5	5.5	35.5	7.9	3.1
2	1.6	10.0	78.4	8.0	35.0	8.1	3.2
3	2.7	8.0	76.0	9.5	31.5	9.0	3.5
4	3.6	38.0	72.2	2.5	34.5	8.1	3.2
5	3.7	33.0	66.8	8.2	25.0	11.5	4.5
6	3.8	38.0	71.5	4.0	32.0	9.0	3.5
7	4.0	40.0	74.6	6.0	32.0	9.0	3.5
8	4.8	41.0	71.5	10.0	27.5	10.0	4.0

* Maximum rate of liquid flow from top of column, without flooding, at start of test was 4.7 litres per hour, later it was 4.2 litres per hour

† Maximum rate of liquid flow from top of column, without flooding, when packing was new was about 4.7 litres per hour, a probable average value is 3.8 litres

(39-in.) in overall height. The column is 10-mm inside diameter and is packed for a length of 41-cm (16-in.) with one-turn glass helices [41, 1934, 45, 1933]. When tested with the binary mixture of *n*-heptane and toluene, the column was found to have the equivalent of 11 to 12 perfect plates, as the data in Table IV show. The different behaviour of carbon tetrachloride-benzene mixtures is probably due to the wider differences in physical and chemical properties than is the case with hydrocarbons. With hydrocarbons

a rate of boiling of 400 to 500-c.c. of liquid per hour under total reflux is possible without flooding.

To reduce heat loss from the column it is jacketed by vapours rising from the still. At the start of the fractionation the stopcock at the left of the column is opened. Because the pressure drop through the open annular space is less than through the packing, the vapours quickly rise in the annular space and heat the column. These rising vapours expel the air present in the annular jacket, and

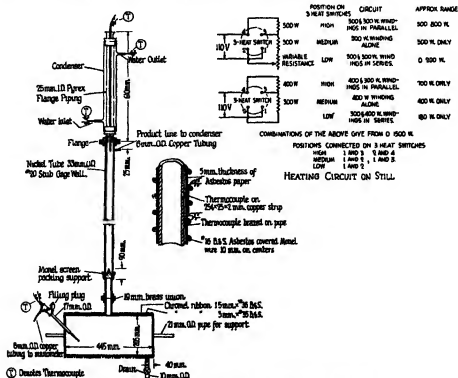

FIG 21 A simple type of efficient fractional distillation apparatus

TABLE III
HETP Tests using One-turn Helices
(In nickel column, 32 mm i.d. and 2.74 metres packed section)

Run no	Velocity of liquid at top, l/hr	Pressure drop mm of Hg	Mol % more volatile component		Total theoretical plates	HETP		
			Distillate	Still		Cm	In	
<i>Normal heptane and methylcyclohexane*</i>								
1	5.2	17	51.0	20.7	21.5	13.5	5.3	
2	5.5	18	47.0	19.3	20.5	14.0	5.5	
3	5.6	18	48.0	18.0	22.0	13.0	5.1	
4	5.8	22	45.8	17.5	21.5	13.5	5.3	
5	5.9	17	52.2	23.4	18.0	16.0	6.0	
6	6.0	22	63.8	20.7	29.0	9.9	3.9	
7	6.3	32	62.0	19.3	29.5	9.7	3.8	
<i>Carbon tetrachloride and benzene†</i>								
1	4.2	19	56.5	13.0	17.0	17.0	6.7	
2	4.7	24	56.2	11.6	17.5	16.5	6.6	
3	5.4	34	64.5	14.5	20.0	14.5	5.7	
4	5.6	36	69.0	24.5	19.0	15.0	6.0	
5	5.7	33	62.2	16.5	18.0	16.0	6.3	
<i>Methylcyclohexane and toluene</i>								
1	4.3	14	90.4	12.0	19.5	15.0	5.9	
2	4.4	14	90.4	16.7	18.5	15.5	6.2	
3	5.4	16	90.7	8.9	20.0	14.5	5.7	
4	5.6	20	90.4	5.4	21.0	13.5	5.4	

* Maximum liquid rate without flooding was 6.2 litres per hr

† Maximum liquid rate without flooding was 5.7 litres per hr

after they have reached the condenser the stopcock is closed. The vapours are now forced up the column and, as heat loss occurs, some condensation takes place in the annular space, the correct temperature level being thus maintained. Their condensation then draws more vapour into the annular space, with the net result that the heat loss from the column is compensated for by a slightly higher rate of boiling in the still. This method has the advantage

counting the number of times per minute this cup empties, and noting the rate of product withdrawal from the column, enables the reflux ratio to be known.

The heating of the still has been designed so that 90 per cent or more of the charge may be distilled off without interfering with or slowing down the rate of boiling. Performance curves for this apparatus are shown in Figs 23, 24, 25, 26 [4], 1934].

The Podbielniak apparatus shown in Figs 27 and 28 is well known throughout the petroleum industry. These columns contain a wire spiral as the equivalent of packing material and the columns are operated with partial condensers. The low-temperature column, or that used for the analytical fractionation of the normally gaseous hydrocarbons, is used very extensively in the natural gasoline industry or wherever there is need for an analysis of hydrocarbon gases. Liquid air is commonly used for condensing these gaseous hydrocarbons, and the entire apparatus, as well as technique for operation, has been carefully worked out. A special vacuum jacket has been developed which enables smooth operation to be attained even though the material undergoing distillation may be liquid methane. The normally gaseous hydrocarbons resulting from the fractionation are measured and collected as gases in the necessary auxiliary apparatus. Podbielniak has also developed an automatic apparatus capable of plotting its own fractional distillation curve [31, 1933].

The Podbielniak high-temperature apparatus (Fig 28) employs a special quartz vacuum jacket for the fractionating column permitting distillation temperatures up to 400° C or more, provided that the materials being distilled can withstand these temperatures without decomposition. The apparatus is therefore fitted so as to enable vacuum fractionations to be made for the case of high-boiling materials.

Another type of low-temperature fractionating column is shown in Fig 29 [13, 1929]. Here the column consists of a long spiralled tube usually containing no packing material whatever. The pitch of the spiral must be such

TABLE IV
HETP Tests at Total Reflux in Glass Column

Run no	Rate of liquid boiling, cc/hr	Mol % more volatile component		Total theoretical plates	HETP	
		Distillate	Still		Cm	In
<i>Normal heptane and toluene</i>						
1	110	88.5	19.0	12.5	3.6	1.4
2	130	87.2	15.9	12.3	3.6	1.4
3	240	87.0	22.2	11.5	3.9	1.55
4	390	85.0	9.3	12.5	3.6	1.4
5	410	85.6	19.7	11.5	3.9	1.55
6	410	86.0	18.8	11.5	3.9	1.55
7	410	85.0	15.2	11.5	3.9	1.55
8	420	85.2	26.4	11.5	3.9	1.55
9	420	87.0	77.0	12.0	3.7	1.45
10	420	89.4	32.0	11.5	3.9	1.55
<i>Carbon tetrachloride and benzene</i>						
1	360	50.0	27.5	8.0	5.9	2.3
2	370	29.2	9.1	8.0	5.9	2.3
3	390	46.3	22.0	9.0	5.1	2.0
4	450	43.0	21.5	8.0	5.9	2.3
5	490	46.3	21.0	9.0	5.1	2.0

that the proper temperature level for the column is automatically maintained. This manner of reducing heat loss from the column has been found suitable for materials boiling up to 140° C. For higher-boiling liquids a small electrical resistance winding around the air jacket surrounding the column may be used to afford ample additional control of heat loss.

The volume of refluxing liquid is measured by a small siphon cup having a capacity of about 1-c.c. and is attached to the lower end of the column as shown in Fig. 22. Simply

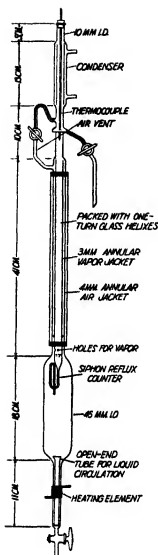

Fig 22 All-glass apparatus with vapour-jacketed fractionating column

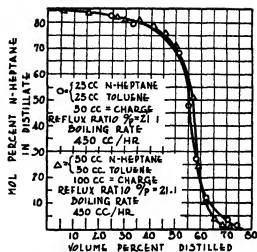

Fig 24 Effect of still capacity on the performance of apparatus shown in Fig 22

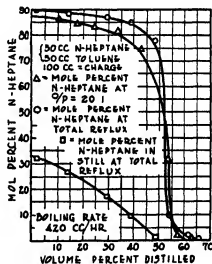

Fig 25 Comparison of operation at 20:1 reflux ratio and total reflux for apparatus shown in Fig 22

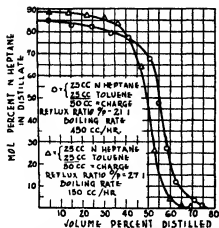

Fig 23 Effect of boiling-rate on the performance of apparatus shown in Fig. 22

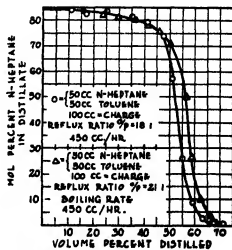

Fig 26 Duplicate fractionations in apparatus shown in Fig. 22

as to enable the liquid reflux to descend sufficiently rapidly to avoid flooding the column. A partial condenser is again used as shown, and the product may be collected as a liquid instead of as a gas.

Vacuum Fractionating Columns

Vacuum fractionation is used wherever it is necessary

the principal factor determining the lower limit of pressure. There is no advantage in having the pressure, say, 1 mm at the top of a fractionating column when the pressure drop through it may be 30-mm. Additional care must be given to the choice of the fractionating column to avoid undue pressure drop. For this reason it is also very good practice in vacuum fractionations to know the temperature in the

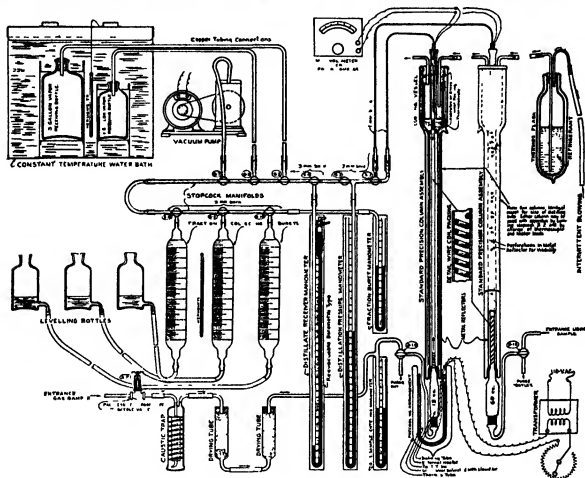

Fig 27 Podbielniak low-temperature fractional distillation apparatus

to separate or segregate liquids that cannot be boiled at atmospheric or ordinary pressures without decomposition. While there is no particular value for the pressures to be used, in general those employed are of the order of 10-mm to 30-mm or else below 1-mm. Obviously the higher the pressure used the more the problem resembles ordinary pressure fractionation, and conversely the lower the pressure used the more the practical operating difficulties likely to be encountered. In general, the pressure need not be reduced below that necessary to enable the material being fractionated to be thermally stable. For the most part vacuum fractionations at 10-mm to 30-mm, while somewhat more troublesome to carry out than atmospheric fractionations, are nevertheless quite smoothly and effectively done in some form of packed column. The throughput is ordinarily less than at atmospheric pressure, but the reduction is not at all proportional to the reduction in pressure, being for 20-mm perhaps of the order of one-third that at atmospheric pressure.

The pressure drop through the fractionating column is

still. In general, lower pressure drop may be obtained at a sacrifice of column efficiency or by increased HETP values. Here again it is difficult to find a packing material that will simultaneously afford (1) high throughput, (2) low-pressure drop, and (3) high efficiency or low HETP. For fractionations at pressures of the order of 10 mm of mercury the small wire helices (nos 5 and 6 in Fig 10) have been found to be good general type packing materials. They may be made of metal or glass.

Fig 30 shows a vacuum fractionation apparatus using these six-turn helices made of no 26 B and S gauge wire wound on a 3.2-mm (0.125-in) diameter rod [23, 1931]. In the case of vacuum fractionations the heating of the still needs to be particularly uniform so as to attain smooth and steady operation of the column. The aluminum block heater *A* is very satisfactory. Ample distillation rates are possible without bumping of the liquid in the still. The column proper is fitted with two glass joints. Having the cup *C* attached to the lower fitting enables a mercury or

heavy oil seal to be used To reduce heat loss from the column as well as in the condenser the heated jackets *E* and *G* are used The condenser *J* is a total condenser, liquid running off it into the tube *I* This is a straight tube flared at the top, but containing a flat piece of copper or platinum sealed into it as a bottom In this thin, flat, metal

at atmospheric pressure without breaking the vacuum on the fractionating column

An example of the results obtained with this column is given by the following data A mixture of 50-c c of decalin of b p 185–188° C at 735-mm and n_D^{20} 1.478, and 150-c c of tetralin of b p 203–206° C at 735-mm. and n_D^{20}

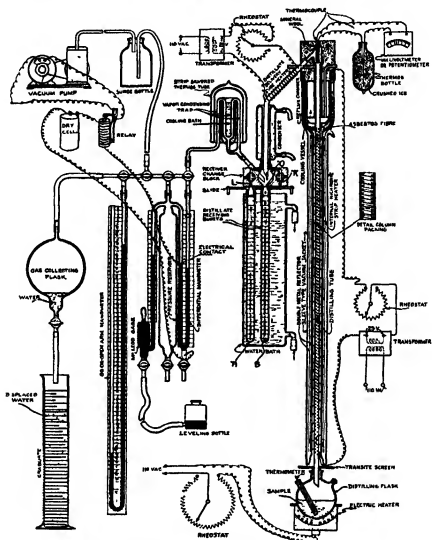

FIG 28 Podbielniak high-temperature fractional distillation apparatus

bottom is a small hole, out of which the liquid reflux escapes This small plate is a sharp-edged orifice, enabling tube *I* to be calibrated to read the amount of liquid flowing through it in a given time For various rates of flow there will be different heights of liquid in tube *I* With a sharp-edged orifice the reading will be least affected by the viscosity of the liquid being fractionated, i e the tube *I* will read volume of liquid flow independent of its viscosity The liquid flowing out of the bottom of tube *I* flows into cup *H*, where any suitable amount may be drawn out through stopcock *K* as product, the remainder overflowing *H* and descending the column as reflux Knowledge of the total amount of liquid condensed by means of *I*, and that drawn out as product in a given time as measured at *M*, enables the reflux ratio to be obtained The volume of tube *I* should be kept small The distillate collection at *M* and *Q* enables product to be withdrawn intermittently

1.540 was fractionated at 25–20-mm pressure, using a 10:1 reflux ratio The distillate was collected in 10-c c. fractions, and the refractive index of each was determined Fig 31 shows the distillation curve Examination of the curve shows that 60% of the decalin (fractions 1–3) and 67% of the tetralin (fractions 9–19) were obtained in a state of purity equal to that of the starting materials Sixty-five per cent of the original charge was obtained as pure product, while the intermediate fractions and hold-up accounted for the remaining 35% A rate of boiling of the order of 600-c c of liquid per hour was possible without flooding the column or sacrificing the smooth operating or boiling conditions For comparison purposes, the results are also shown of the distillation of a material of the same percentage composition using only an ordinary distilling flask at 17–20-mm. pressure.

Another type of vacuum fractionating column is shown

in Fig 32 [8, 1932] Here the packing is small jack chain suspended from a metal ring, and the column, 12-mm (0.47-in) in diameter and about 90-cm (3-ft) long, is also provided with electric heating and a vacuum jacket Provision for a thermometer is shown at *E* and a total condenser at *F* A suitable regulating valve for the product is shown at *H* which employs mercury as the regulating

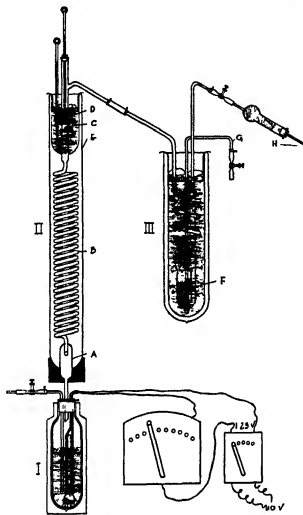

FIG 29 Spiraled tube fractionating column for analysis of normally gaseous hydrocarbon mixtures

means Turning inward the knurled knob *P* compresses the rubber tube *J*, forcing the mercury into the U-bend at *G*, thereby providing regulation of the liquid flowing out of the column as product Results of fractionating a three component mixture in this column at 8 mm pressure are shown in Fig 33

A column used for the vacuum fractionation of lubricating oils is shown in Fig 34 [29] The column normally is operated at about 0.2-mm to 0.5-mm at the top and 1.0-mm to 1.5-mm at the bottom This necessitates a packing that will afford very low pressure drop The column proper is about 5-ft. long (1.5-metres), constructed from 1.25-in standard steel pipe The packing consists of two sets of metal disks or washers, one set having a diameter of 19-mm to 22-mm (0.75-in. to 0.87-in.), the other fitting closely the inside of the 1.25-in. standard pipe, being therefore 35-mm (1.38-in.) in diameter The smaller disk has a hole in it 7.9-mm. (0.312-in.) in diameter fitting snugly on to a rod

B of the same diameter The larger disk has a hole in it of approximately 19-mm (0.75-in) diameter The small disks are brazed to the vertical rod at 7.6-cm (3-in) intervals, and the large disks are similarly equally spaced along the rod, but in between the smaller disks In the case of the large disks there is an annular space between the disk and the rod so that the disk is joined to the rod by means of a U-shaped piece of metal wire as shown When finished the packing constitutes one piece, namely, the rod with alternating equally spaced disks When placed inside the 1.25-in standard pipe, the vapours are forced to take a zigzag path in and out of the disks, for one set fits the rod snugly, the other the walls of the column snugly As the vapours reach the top of the column they enter the holes in tube *G* and come in contact with the total condenser *J* where they condense to liquid Liquid collects in *I* and flows down the walls of tube *G* and is led on to the rod *B* containing the disks or washers As the liquid descends it spreads out over the small disk and back on to the rod again At the velocities used very little, if any, of the liquid drops off or falls freely down the column as drops, but rather it is led in film form down the rod and over the small disks In this way there is good vapour-liquid contact with a minimum of pressure drop

Pipe *C* placed around the column affords an annular air space so that adiabatic conditions at high temperatures may at least be approximated Pipe *C* is wound with electric heating wire, and not only serves to reduce heat losses from the column, but materially aids in bringing the column up to temperature at the start of a fractionation Thermocouples suitably placed in the usual way along the column and pipe *C* permit any necessary temperature level to be maintained

The condenser *J* is a length of approximately 4.5 metres (15-ft) of 7.9-mm (0.312-in) diameter tubing coiled as shown Thermocouples at *L* read the inlet and outlet temperatures of the cooling water, for knowledge of the vapour flow in the column is obtained by calculation of the heat imparted to the condenser water The product receiver is any suitable size, perhaps of the order of 100 cc

The still is designed to hold a charge of about 1 litre, and is electrically heated by circular heaters placed on the bottom This design of still is simple, affords a large heating area, and at the same time does not permit a high static head of oil on the heating surface For boiling at low pressures it is very desirable to have a low liquid head on the heating surface to reduce superheating

A column of the design shown can be operated with quite a variation in rate of boiling Consequently McLeod gauges are attached to the still as well as to the top of the column to permit the pressure drop through the column to be known In this way the vapour velocity can be held at a value corresponding to the allowable pressure drop With light oils the boiling-points are sufficiently low to permit high velocities and consequently a higher pressure drop, and likewise a higher still temperature without danger of thermal decomposition In distilling Pennsylvania viscous neutral oils (approx 180 Saybolt at 100° F) in this apparatus it is possible to have a rate of boiling equivalent to about 600-c.c of liquid per hour with a pressure drop of about 2-mm., when the pressure at the top of the column is 0.2-mm to 0.4-mm The column is usually operated without any attempt at maintaining a fixed and predetermined pressure value Rather it is operated with the vacuum pump running constantly, and under these conditions

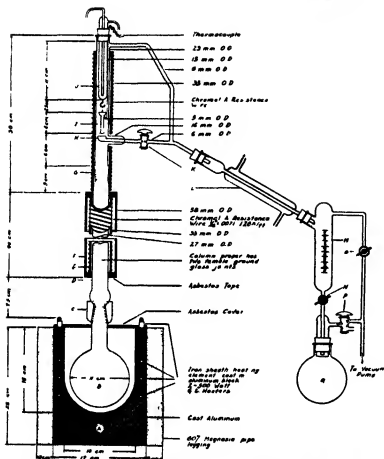

Fig. 30 Laboratory apparatus for fractional distillation at reduced pressures

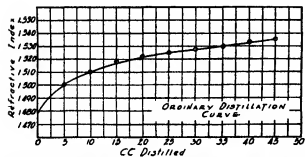
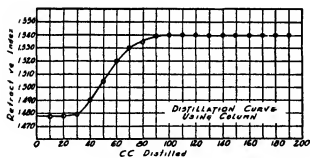

Fig. 31 Comparison of simple and fractional distillations of decalin and tetralin mixtures at 20-30 mm pressure. Fractional distillation made with apparatus in Fig. 30

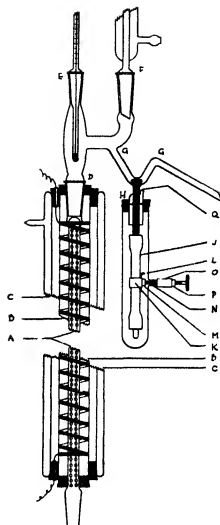

Fig. 32 Vacuum fractionating column employing strands of chain as packing material

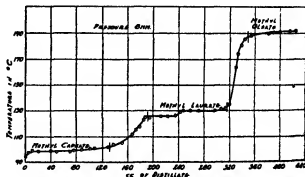

Fig. 33 Results of vacuum fractionation at 8 mm. pressure with column shown in Fig. 32.

reasonably constant pressures are obtained. No attempt is made to use the temperatures in the column for other purposes than following the general course of the fractionation and permitting the proper control of the operation of the column such as heat loss from the column, checking excessive still temperatures, &c. The fractions obtained are distilled separately in a vacuum Engler apparatus operating at 10 mm controlled pressure, or in the apparatus described earlier under Simple Distillation operating at 1 mm controlled pressure.

The efficiency of the fractionating apparatus shown in Fig. 34 was tested at atmospheric pressure as well as under

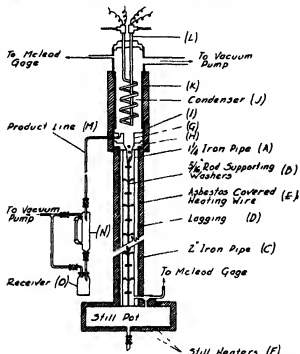

FIG. 34 Apparatus for vacuum fractionation of lubricating oils

vacuum. At atmospheric pressure the column was tested under total reflux with a mixture of carbon tetrachloride and benzene. At a superficial vapour velocity corresponding to 1 ft. per sec. the HETP was 10 in., indicating that the column was equivalent to 6 perfect plates.

It is more difficult to test a column under vacuum, for there is no binary liquid mixture with complete analytical data available. To make the test two oils, one a California other a Pennsylvania, were fractionated to give two narrow cuts boiling about 28° C. apart. The data are shown in Fig. 35. These two oils, because they are narrow fractions, could be treated as two single substances for distillation purposes, and a 50-50 wt % mixture was fractionated with the results shown in Fig. 35. During the fractionation the average reflux ratio was approximately 12 to 1. Also from the vapour-pressure data on these two oils it was possible to construct the usual vapour-liquid diagram assuming perfect gases and perfect solutions. During the fractionation samples were taken of the distillate and liquid in the still, and as samples were obtained simultaneously while operating at a 13 to 1 reflux ratio, they could be assumed steady state samples. Using the McCabe and Thiele method for distillation calculations for binary mixtures it was possible to calculate the theoretical plates in the column under these conditions

The results gave a HETP of 12 in., which is in reasonable agreement with the 10 in. obtained at atmospheric pressure [29].

Additional performance curves for the apparatus shown in Fig. 34 are given in Fig. 36.

Another fractionating column for use at pressures of the order of hundredths of a millimetre or less is shown in Fig. 37 [26, 1935]. Here the packing is a continuous spiral of the sort used by Podbielniak. No data on the performance of this apparatus are available.

Molecular Stilts

In a molecular still the process resembles more closely one of evaporation rather than boiling. In the gas phase there is more or less unrestricted movement of the molecules, that is, the mean free path is large. In the ideal case molecules leaving the surface of a solid or liquid do not collide with any other molecules before they hit a colder surface on which they condense. Essentially, in its most common form, the process resembles simple distillation in that the molecules leaving a solid or liquid become a gas, which in turn is directly condensed to the solid or liquid state. It follows that in order to have a large mean free path the pressure must be low, it is generally below 0.001 mm (1 micron).

The essential features [21, 1932, 43, 1929] of a molecular still are the following:

- 1 A vacuum equal to or better than the vapour pressure of the substance at the distilling temperature is necessary.
- 2 There must be a short distance between the evaporating surface and the condenser. Preferably this distance is less than the mean free path of the molecules in the gas phase.
- 3 A large and clean evaporating surface is necessary. The amount evaporating is directly dependent on the surface area, providing it is all at substantially the same temperature. The surface must be free from any foreign molecules of much lower volatility.
- 4 There must be an ample difference in temperature between the evaporating and condensing surfaces.

Molecular stilts are useful principally for high molecular weight substances which cannot be vaporized in any other way. Mercury, calomel, and paraffin wax have been distilled at ordinary temperature and cane sugar has been distilled at 120° C. [43, 1929].

The following equation for the rate of evaporation has been derived on the basis that there is unimpeded movement in the gaseous molecules, that every molecule that strikes the cold surface condenses, and that there is no reflection from this surface [22, 1911, 24, 1913],

$$w = 1333p \sqrt{\left(\frac{M}{2\pi RT}\right)}$$

w = gram distilling from 1 sq. cm. of surface in 1 sec.
 M = molecular weight of the substance in gram per gram mol,

π = 3.1416,

R = 8.316 $\times 10^7$, molecular gas content in ergs per degree,

T = temperature in degrees Kelvin,

p = absolute pressure in mm. of mercury.

Assuming spherical molecules, that any one molecule is moving with a uniform velocity determined by the kinetic equation for gases, and that the other molecules

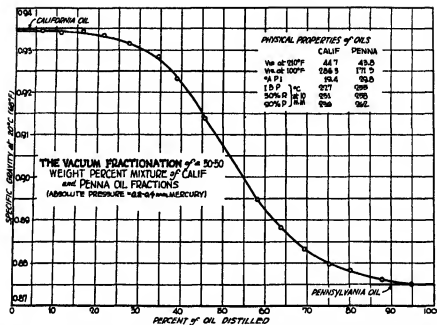

FIG 35 Vacuum fractionation of a 50-50 mixture of two narrow boiling oils in apparatus of Fig 34

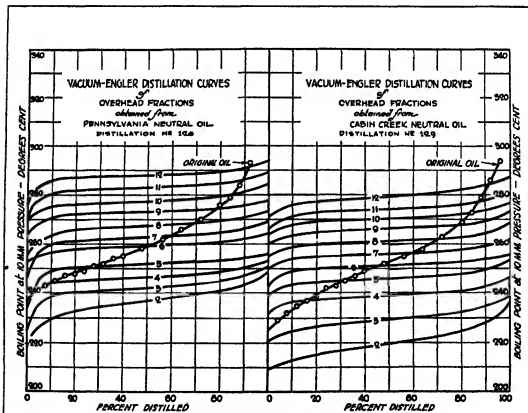

FIG 36 Results of vacuum fractionation of lubricating oils in apparatus of Fig. 34

among which it is moving are stationary, the following equation may be derived [25, 1934]

$$l = \frac{RT}{6.06 \times 10^{22} (p) (4\pi) (r^2)}$$

l = mean free path in cm,
 R = 82.07, molecular gas constant in c c atmospheres,
 p = absolute pressure in atmospheres,
 π = 3.1416,
 r = radius of a molecule in cm

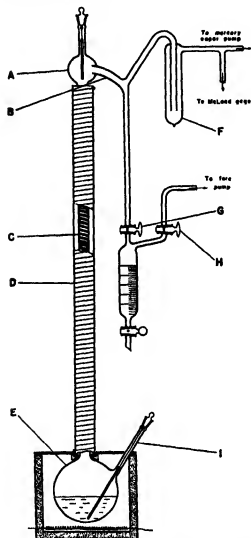

FIG. 37 Vacuum fractionating column employing a spiraled wire as a packing material

The equation for the rate of evaporation may be applied to any one of a number of components that may be present. Thus the molal ratio of two substances which have passed from the liquid to the vapour phase is directly proportional to the ratio of vapour pressures and inversely proportional to the ratio of molecular weights. As an illustration of the use of the two equations above, assume that a hydrocarbon of molecular weight 400, and molecular diameter 8×10^{-8} cm [12, 1934] is to be distilled at 400° K and at a pressure of 0.001 mm. The rate of distillation is calculated to be 0.21 g per hour per sq. cm of evaporating surface, and the mean free path for these conditions is

II

2 cm. The condensing surface should then be 2 cm or less distant from the evaporating surface.

One form of molecular still for distilling liquids is shown in Fig. 38 [36, 1935]. The liquid is contained in flask *E* and condenses on surface *B*, and runs down the walls to escape at *D*. Another form adaptable for distilling solids is shown in Fig. 39 [40, 1935]. Here the apparatus has been made of two pieces of flanged Pyrex pipe to enable the apparatus to be dismantled. The material to be dis-

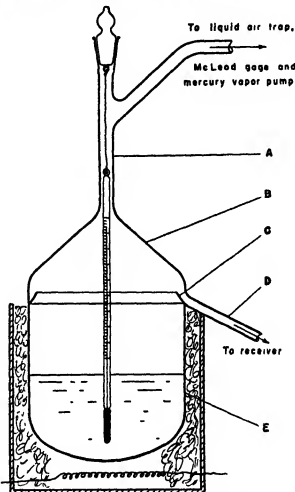

FIG. 38 Molecular still suitable for distilling liquids

tiled or sublimed is placed in the well, which is heated in an oil bath. Cooling medium circulates through the condenser and the solid condenses on the lower part of the condenser.

An apparatus permitting more than one distillate from a liquid to be obtained at one time is shown in Fig. 40 [36, 1935]. Here the liquid, for example, hydrocarbon oil, is contained in flask *C* and by means of the solenoid actuated valve *I* is permitted to drop on to the outside of vertical tube *L*. The inside of tube *L* is heated by a suitable liquid boiling in flask *S*. This latter liquid and its vapour is entirely separate from that in flask *C*. The hot vapours on the inside of tube *L* evaporate the liquid flowing down the outside of this same tube, these vapours condense on the cold walls *M*, and flow out through *N* and *O* into receivers *P*. The annular space between *L* and *M* is held at a very high vacuum by being connected to a high

vacuum source at *E*. Heater *D* serves only to keep the contents of flask *C* preheated. The inside of tube *L* is packed with suitable packing material, for example, jack chain. If now, for example, the liquid in still *S* were kerosine, the inside of tube *L* would serve as a fractionating column and so there would be a temperature gradient established along tube *L*. The condenser *G* would serve to condense the kerosine and reflux it back down tube *L*. The top part of tube *L* would be colder than the bottom so that the most volatile components of the liquid in

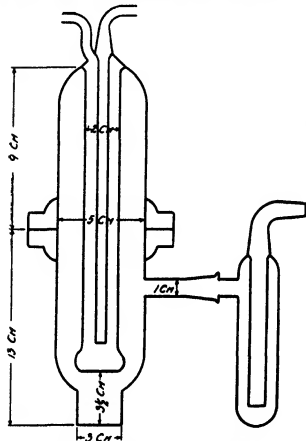

FIG 39 Molecular still for sublimation of solids

flask *C* would be concentrated in the top receiver *P*, while the least volatile would likely fail to vaporize and be concentrated in the lowest receiver. This apparatus has been used successfully in vaporizing and separating high-boiling, high molecular weight lubricating oils [36, 1935]

Other Types of Distillation Equipment

If a binary mixture of *A* and *B*, two components boiling quite far apart, is distilled in a simple distilling flask, the distillation temperature steadily rises as the distillation proceeds, or as vapours are withdrawn. The higher boiling component, *B*, in this case, is of course distilling at all times with *A*. If the problem is to vaporize the maximum amount of *B* in the mixture at some definite fixed temperature limit, it will be found that this is accomplished not by performing a simple distillation and stopping it when the fixed temperature is reached, but by arranging to carry out the distillation so that all the vapour is separated from the liquid at the fixed temperature level, and none is permitted to escape below this temperature. This is the ideal case. In other words, all the vapour is saturated with *B* at the

highest allowable temperature, for it is here that *B* has its highest vapour pressure. This type of operation is called flash distillation or flash vaporization. A simple example will further illustrate the argument. Consider a mixture of one mol of *A* and one mol of *B*. These form perfect solutions, and the ratio of vapour pressures over the temperature range to be used may be assumed constant.

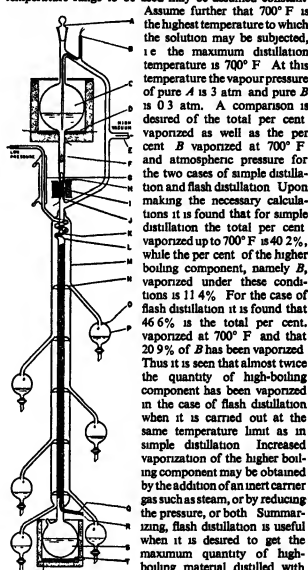

FIG 40 Continuous type of molecular still

is frequently desirable. The essential requirements of flash distillation are to have the charging material heated to the highest allowable temperature, in the shortest time, and to provide that all the vapours leaving the liquid be in equilibrium with all the liquid at this temperature.

A laboratory flash-distillation apparatus is shown in Fig 41 [37, 1935]. Here in order to utilize temperature as well as heat most effectively, the preheating and vaporizing of the material is done in a lead bath. Superheated steam as well as vacuum is employed to get a high per cent. of the charging material vaporized.

Another type of flash-distillation apparatus is shown Fig 42 [29]. Here Dowtherm (eutectic mixture of diphenyl and diphenyl oxide) is the heating medium. Dowtherm

Assume further that 700° F is the highest temperature to which the solution may be subjected, i.e. the maximum distillation temperature is 700° F. At this temperature the vapour pressure of pure *A* is 3 atm and pure *B* is 0.3 atm. A comparison is desired of the total per cent vaporized as well as the per cent *B* vaporized at 700° F and atmospheric pressure for the two cases of simple distillation and flash distillation. Upon making the necessary calculations it is found that for simple distillation the total per cent vaporized up to 700° F is 40.2%, while the per cent of the higher boiling component, namely *B*, vaporized under these conditions is 11.4%. For the case of flash distillation it is found that 46.6% is the total per cent vaporized at 700° F and that 20.9% of *B* has been vaporized. Thus it is seen that almost twice the quantity of high-boiling component has been vaporized in the case of flash distillation when it is carried out at the same temperature limit as in simple distillation. Increased vaporization of the higher boiling component may be obtained by the addition of an inert carrier gas such as steam, or by reducing the pressure, or both. Summarizing, flash distillation is useful when it is desired to get the maximum quantity of high-boiling material distilled with the minimum possibility of thermal decomposition. In lubricating-oil preparation this

vapours are generated in *B* by boiling the liquid by means of electric immersion heaters *C*. The vapours pass up through *E* and through *F* where they enter the flash-vaporization section *K*. This consists of a length of square tubing *H*, containing a large number of small tubes *J*, which are arranged at right angles as shown, using the four sides of the square tube as headers. Dowtherm vapours are forced to flow in parallel through all these tubes because plates *O* on opposite edges of the square tube are welded to the square tube as well as to the walls of the enclosing cylindrical pipe *K*. Plates *L* at the top join the walls of *K*

disengaging section and a conical deflector *I* which serves to keep any liquid from flowing out through *A*. The vapours formed in the flash distillation flow out through *A*, and to any suitable condenser that may be attached thereto. A source of vacuum may be applied to the condenser, so placing the entire flash-vaporizing section under

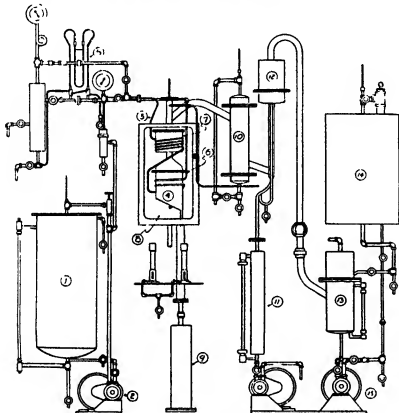

FIG 41 Vacuum flash distillation apparatus.

with the walls of the square tube *H*, so that the top contains only the opening of the square tube, into which projects a spray nozzle *M*. In other words, Dowtherm vapours enter at *F*, and must pass through the criss-crossed small tubes *J* before they can escape out through *O*. In this way the square tube is completely surrounded by Dowtherm vapours, and thereby effectively protected against heat loss to the surroundings. The material to be flash vaporized, for example, oil, is pumped in at *N* through the preheater coil, and sprayed out at *M* over the small tubes *J*. The oil in film and drop form passes down through the layers of tubes *J*, which function in two ways (1) they serve as a type of low pressure-drop packing material ensuring that the vapour and liquid flowing concurrently down through the apparatus will be in equilibrium with each other by the time they reach the lower level of tubes, and (2) they simultaneously serve as an extensive heating surface from which the heat of vaporization of the oil is obtained. It is the Dowtherm condensing on the inside of tubes *J* that furnishes the heat of vaporization for the oil flowing downwards on the outside of these tubes. Below tubes *J* is a

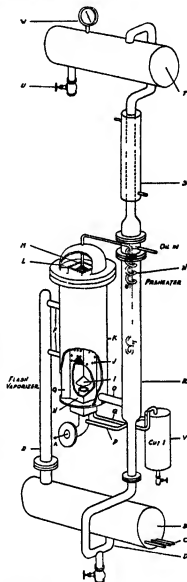

FIG 42 Flash distillation unit employing Dowtherm as the heating medium

vacuum. Liquid in equilibrium with escaping vapours flows out through pipe *Q* into receiver *V*. Pipe *P* is simply a vent enabling the receiver *V* to be at the pressure of the rest of the apparatus. Dowtherm liquid and vapour pass out through *O* into *R* where the liquid Dowtherm flows downwards through *D* back into the Dowtherm boiler *B*. Dowtherm vapours pass up through *R* and the preheater *N* where they preheat the incoming oil. Remaining Dowtherm vapours now pass up through air or water condenser *S* and are completely condensed to liquid which flows down into the boiler *B*. Tank *T* contains nitrogen or carbon dioxide or other inert gas which is applied to the Dowtherm system. Varying the pressure in tank *T*

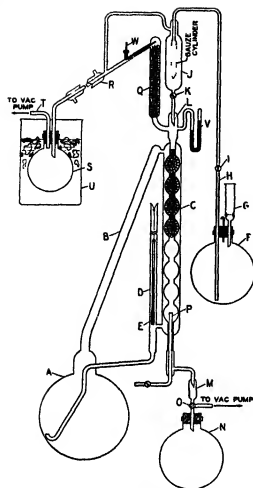

Fig. 43 Continuous laboratory topping unit

imposes any suitable pressure on the Dowtherm, thereby giving any desired constant temperature on the flash-vaporization apparatus. There is then no possibility of oil overheating or hot spots in the flash-vaporization system, and the apparatus is very flexible. The oil is heated effectively, in a short time at the maximum allowable temperature, and under such conditions that it is in substantial equilibrium with all the vapours generated. Inert gas, such as steam, or volatile liquids may also be introduced at *M* to cause additional vaporization. In vaporizing relatively heavy oils it is convenient to add a volatile liquid that is soluble in the oil, for example, a lower boiling hydrocarbon fraction. This liquid upon vaporizing in the apparatus further increases the per cent of heavy oil that is flash vaporized. By choosing this liquid so that it has a relatively low vapour pressure at ordinary temperatures, but yet is practically completely volatile at the vaporizer temperature, vacuum flash distillation is made relatively easy.

Apparatus of the sort shown in Fig. 42 is useful as an isothermal stripping or fractionating apparatus when employing countercurrent (instead of concurrent) flow of vapour and liquid. This may be accomplished in a continuous way by introducing at *M* the liquid to be fractionated or stripped of more volatile components, and by introducing inert gas or vapour at *A*, and by providing a vapour outlet in the top of the hemispherical cap which in turn is connected to a condenser. The stripped liquid then flows out through *Q* into receiver *V*. Depending upon the length of the section containing tubes *J*, and their temperature, and the proportion of gas or vapour introduced at *A*, any suitable degree of fractionation or stripping under substantially isothermal (rather than adiabatic) conditions may be attained.

A continuous laboratory topping apparatus is shown in Fig. 43 [35, 1935]. The heat needed for the distillation is supplied by the hot vapours of a liquid boiling in the flask *A*. These vapours ascend through line *B*, enter the outside chamber of isothermal heating unit *C* at the top, and pass through the chamber and out at the bottom to *D*, where they are condensed and returned to the boiler, thus completing the circuit for the heating medium. The temperature of the vapour leaving the bottom of the still is determined by thermometer *E*. In operation the vapour stream should have a velocity and volume sufficient to maintain this temperature constant, whether or not the topping section is being used.

The topping system may be illustrated by following the paths of crude oil gas and vapours through the apparatus. The crude oil to be topped is poured into storage flask *F* through strainer *G* and drawn by the vacuum in the system through *H* and valve *I* into a degasser and foam breaker *J*. The crude then enters the top of the isothermal heating chamber *C*, through stopcock *K* and drifter *L*. The heating chamber is simply an eight-bulb condenser, the four top

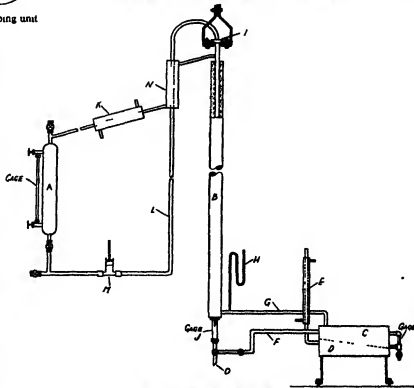

Fig. 44 Batch stripping column

bulbs are packed with no. 18 steel jack chain, and the four bottom bulbs are empty. The chain provides much surface and serves as a heat reservoir to heat the cool, incoming crude quickly. The oil passes downwards through the still and eventually runs out of dripper *M* into topped-off receiving flask *N*. By proper manipulation of stopcock *O*, flask *N* may be removed, emptied, and re-evacuated without stopping the distillation.

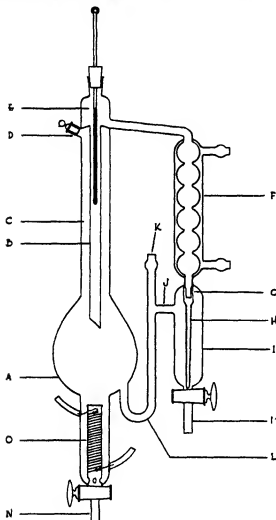

FIG 45 Equilibrium still

While the crude oil is flowing downwards through the heater, a small stream of inert gas is admitted in the centre of the bottom bulb at *P*. This gas rises countercurrent to the descending-oil film and carries the vapours evaporated from the crude into fractionating tower *Q*, also packed with no. 18 steel chain. Here the heavier fractions of the distillates are separated and washed back, while the vapours pass to condenser *R* where they liquefy, the condensate collecting in the receiver, *S*. The gas passes through flask *N* and line *T* to the vacuum pump and thence to the atmosphere. True boiling-point stills for analysis of crudes have also been described [3, 1932].

A batch stripping column is shown in Fig. 44 [29]. In this apparatus the highest boiling components are those that are obtained first, rather than last as in the ordinary type of fractionating (enriching) column. The charge to

be fractionated is contained in *A*, and a small proportioning pump *M* feeds it as liquid at a predetermined and constant rate through preheater *N* to the top of the fractionating tower *B*. For tall columns the method of support shown at *J* is convenient. The liquid passes down through the column and out through sight glass *J* and line *F* into vaporizer *C*. Here it is completely vaporized by a higher boiling liquid boiling in *D* and undergoing reflux condensation in *E*. The surface between *C* and *D* on which the liquid is completely evaporated is large, and by choice of the liquid in *D* it is easily possible to have a very steady

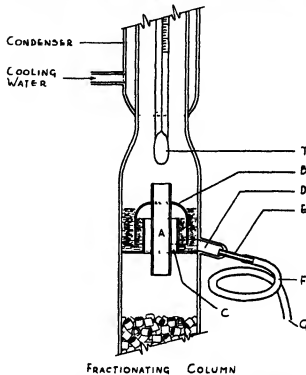

FIG 46 Device for permitting intermittent withdrawal of distillate from a fractionating column

and yet complete evaporation of the liquid in *C*. The gauge shows whether or not the evaporation has been complete. The vapours enter the base of the column through *G*. A manometer, *H*, indicates the pressure drop through the fractionating tower. These vapours then pass up through the tower and thus flow countercurrently to the descending liquid. At the top of the column the vapours pass out through preheater *N* and cooler *K* and are returned as liquid to container *A*. Care should be taken that this liquid mixes completely with the entire liquid in *A*. As this process is repeated the highest boiling component in *A* is gradually concentrated in *J* and line *F*. It may be withdrawn continuously or periodically through *O*. This procedure has been found very effective in separating gasoline into their components or groups of components, where the fractionating column *B* has of the order of 100 perfect plates [29].

The equilibrium still shown in Fig. 45 [26, 1932] is a useful piece of laboratory distillation equipment. It is used to obtain vapour-liquid equilibrium data. Liquid contained in flask *A* is boiled by electric heater *O*. Vapours go up through *B* past the thermometer and into condenser *F*, where they are completely condensed. Care should be taken that no condensation of vapours occurs before the

opening into condenser *F*. Otherwise there would be a change in their composition, and this composition would not be that originally produced by the liquid boiling in *A*.

To eliminate the possibility of condensation in *B* the flask *A* is provided with a long neck *C* which serves to surround *B* completely with vapour. The liquid leaving the condenser *F* is led to the bottom of receiver *I* by tube *H*. A small vent is provided at *G*. The liquid completely fills *I* up to the level *J*, when it overflows through *J* back into flask *A*. The opening *K* is to the atmosphere or to a source of any desired pressure. After the processes of boiling in *A* and condensation in *F* have been repeated many times, the liquid in both *A* and *I* will attain constant compositions unchanging with time. This is the equilibrium state. A simple material balance over the apparatus will show that the liquid in *I* has the composition of the vapours leaving and in equilibrium with the liquid in *A*. In other words, drawing samples of liquid for analysis from *M* and *N* gives the vapour and liquid compositions respectively in equilibrium at constant pressure. Using different liquid compositions in *A*, and proceeding in the same way, gives a series of points on the curve.

In small-scale fractionating columns it is sometimes difficult to control the flow of distillate being withdrawn continuously from the column. Instead of withdrawing it continuously it may be withdrawn periodically or in batches as shown in Fig 46 [29]. Vapours from the fractionating column pass up through tube *A* into the complete condenser. A thermometer is shown at *T*.

Liquid flowing down the walls accumulates as shown and then flows up continuously under bell cap *B*, and down into the fractionating column through annular space *C*. The attachment of a flexible product tube *F*, which may be small-diameter lead tubing, to the glass side tube *D*, of the glass fractionating column may be accomplished by a small length of platinum tubing *E*. The platinum tube is sealed into the glass, while the lead tube is soft soldered to the platinum tube. A suitable metal valve may then be attached at *G*. In operation no product is withdrawn for

a time through *F*. It overflows continuously through *C*, and a quantity of low-boiling material is then produced. If the time is sufficient the composition of this quantity of liquid will become constant, representing that which the column can produce at total reflux. At suitable time intervals this product may be withdrawn to constitute small fractions of distillate.

A batch fractionating column in which the lowest as well as the highest boiling components are simultaneously produced is shown in Fig 47 [29]. The charge, or liquid to be fractionated, is introduced through *O* into flask *P*. At the start the liquid in this flask is boiled by electric immersion heater *N*, with electric leads at *H*. Vapours rise and pass through the holes in tube *I* into the packed fractionating column *E*, and are completely condensed by total condenser *B*. Vent *A* is open to the atmosphere or any desired source of pressure. A thermometer *D*, which would read the boiling-point of the lowest boiling component, is shown. The low-boiling product may be withdrawn through *C* in the usual way. The liquid reflux flows down column *E* countercurrently to the rising vapours, and out through tube *J* and into tube *K*. From here the liquid flows into cup *K*, which is periodically emptied by the siphon attached to it. The liquid now descends the stripping column *Q*, and at the end of this column it is caused to flow on to the walls by means of plates *S* which have a central opening as well as several openings around their edges. Electric heating wire *U* is wrapped around the column as shown, and the liquid is completely vaporized back up the column by this heater. The heat is adjusted so that no liquid accumulates on plate *W*, which is sealed to the walls of column *Q*. A length of capillary tubing is inserted at *X*, and by means of rod *Y* the thermometer *T* is supported as shown. This thermometer reads the boiling-point of the highest boiling components in the mixture being fractionated. A tube for withdrawing the high-boiling materials is provided at *Z* by means of clamp *Y*. The capillary tube *X* permits product vapours to be withdrawn without a great deal of condensation below *W*, which would be unnecessary liquid hold-up. The vapours generated by electric heater *U* pass up through *S* and the packed stripping column *Q*. They then rise through *L* and down through bell *M* and pass out through the slots in the bottom of *M*, thereby bubbling up through the liquid contained in flask *P*. They pass on up through the enriching column *E*. As vapours are generated from *U* the heat at *N* is reduced or completely eliminated. Generally in steady operation enough heat is supplied at *N* to make up for products withdrawn at *C* and *Z*. Jackets *R* and *F* are provided to reduce heat loss from the columns. Cup *K* may be calibrated so that the rate of liquid flow may be obtained from the number of overflows from *K* in a given time. Flange *G* is the same or similar to that used in connecting sections of Pyrex piping. It should be pointed out that the reading on thermometer *T* will be higher than the atmospheric boiling-point if the apparatus is operated under atmospheric pressure, because of the pressure drop through the apparatus. A tee connexion may be provided at *Z*, one side of which leads to a manometer to observe this pressure drop and enable a temperature correction to thermometer *T* to be made. The other tee opening may be for product removal.

A centrifugal countercurrent apparatus for fractional distillation has been developed [32, 1935; 33, 1935]. However, no technical data are as yet available on its performance. Applications would appear to be most suitable for large-scale distillation equipment rather than that of laboratory size.

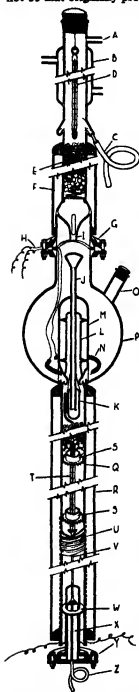

Fig 47 Batch fractionating apparatus for simultaneously concentrating the lowest and highest boiling components

REFERENCES

- 1 A S T M Designation D 86-30 (1934)
- 2 BRATTY, H A., and CALINGBART, G *Ind Eng Chem* 26, 504 (1934)
- 3 BRUWINKER, G A., and CHILD, W C *Ind Eng Chem, Anal Ed* 2, 285 (1932)
- 4 BRUMLEY, E W., and QUIGGLE, D *Ind Eng Chem* 25, 1136 (1933)
- 5 BRUNN, J H., and SCHICKTANZ, S T *U S Bureau of Standards J Research*, 7, 851 (1931)
- 6 ——— *Ind Eng Chem*, Anal Ed 1, 212 (1929)
- 7 ——— *Ind Eng Chem*, Anal Ed 7, 359 (1935)
- 8 BURB, M T., and SCHWARTZ, A M *Ind Eng Chem*, Anal Ed 4, 142 (1932)
- 9 CAULTON, T H., and COLBURN, A P *Ind Eng Chem* 27, 255 (1935)
- 10 COOPER, C M., and FASCE, E V *Ind Eng Chem* 20, 420 (1928)
- 11 COTTELL, F G *J A C S* 41, 721 (1919)
- 12 DAVIS, W P *A Study of Crystal Structure and its Applications*, 557 (McGraw-Hill, 1934)
- 13 DAVIS, H S *Ind Eng Chem*, Anal Ed 1, 61 (1929)
- 14 ELLIS, L M, JR *Ind Eng Chem*, Anal Ed 4, 319 (1932)
- 15 FENKEL, M R *Ind Eng Chem* 24, 482 (1932)
- 16 FENKEL, M R., QUIGGLE, D., and TONBERG, C O *Ind Eng Chem* 24, 408 (1932)
- 17 ——— *Ind Eng Chem* 24, 542 (1932)
- 18 ——— *Ind Eng Chem* 26, 1169 (1934)
- 19 HERBST, W A Chem Eng Doctor's Thesis, 1935, The Pennsylvania State College
- 20 HERBERG, E B., and HUNTRESS, E H *Ind Eng Chem*, Anal Ed 5, 344 (1933)
- 21 HICKMAN, K *J Franklin Institute*, 213, 119 (1932)
- 22 KNUDSEN *Ann Phys* 34, 593 (1911)
- 23 KRUGGER, P A *Amer Chem Soc, 4th Organic Symposium*, New Haven, Dec 1931
- 24 LANGMUIR, I *Phys Rev* 2, 331 (1913)
- 25 NOTER, A A., and SHERRILL, M S *Chemical Principles*, 30 (McGraw-Hill, 1934)
- 26 OTTNER, D F *Ind Eng Chem*, Anal Ed 4, 233 (1932)
- 27 PALKIN, S *Ind Eng Chem*, Anal Ed 7, 436 (1935)
- 28 PETERS, W A, JR *Ind Eng Chem* 14, 476 (1922)
- 29 Petroleum Refining Laboratory, The Pennsylvania State College FIVRIS COMMUNICATION
- 30 PODREBNIAK, W J *Ind Eng Chem*, Anal Ed 5, 119 (1933)
- 31 ——— *Ind Eng Chem*, Anal Ed 5, 172 (1933)
- 32 ——— U S P 2,003,308 (4 June 1935)
- 33 ——— U S P 2,004,011 (4 June 1935)
- 34 QUIGGLE, D., TONBERG, C O., and FENKEL, M R *Ind Eng Chem*, Anal Ed 6, 466 (1934)
- 35 RALL, H T., and SMITH, H M *Ind Eng Chem*, Anal Ed 6, 373 (1935)
- 36 ROSSINI, F D A P I Meeting, Tulsa, Okla., 15 May 1935
- 37 SCHEUMANN, W W., and STEWART, J F A P I Meeting, Tulsa, Okla., 15 May 1935
- 38 SCHICKTANZ, S T *U S Bureau Standards Journ Research*, 11, 89 (1933)
- 39 SHERWOOD, T K., and GILLILAND, E R *Ind Eng Chem* 26, 1093 (1934)
- 40 STRAIN, W H., and ALLEN, W M *Ind Eng Chem*, Anal Ed 7, 443 (1935)
- 41 TONBERG, C O., QUIGGLE, D., and FENKEL, M R *Ind Eng Chem* 26, 1213 (1934)
- 42 WALKER, LEWIS, and McADAMS *Principles of Chemical Engineering*, 2nd ed., McGraw-Hill, 1927
- 43 WARHORN, E W *U S Bureau Standards J Research*, 2, 476 (1929)
- 44 WATSON, K M., and WIRTH, CHAS *Ind Eng Chem*, Anal Ed (1935)
- 45 WILSON, C D., PORTER, G T., and LAUGHLIN, K C *J A C S* 55, 2795 (1933)

THE MANUFACTURE OF WHITE SPIRITS, SPECIAL NAPHTHAS, AND PETROLEUM SOLVENTS, BY DISTILLATION

By L. CLEMENT, M.A., F.I.C., M. Inst. P.T.

Shell Refineries, Ltd

The manufacture of white spirits and special naphthas from crude oil generally requires more than one distillation. The usual practice is to separate first a crude white spirit and a crude benzene and then to redistil the crude white spirit and crude special naphtha. The first stage in the manufacture of crude white spirit and crude special boiling-point spirit would be effected by means of the usual type of continuous distillation plant for crude oil, involving a modern fractionating column, such as is diagrammatically illustrated in Fig 1.

In this plant the crude oil leaves the heaters at a temperature of 275° C and passes into the 6 ft by 17 ft 6 in

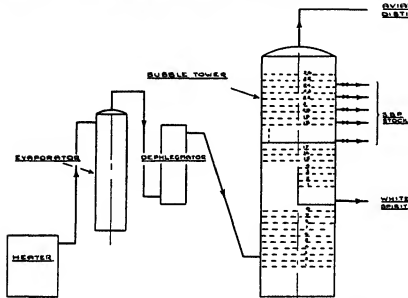

FIG 1

evaporator. The vapours from the evaporator are discharged through two 12-in lines to two dephlegmators in parallel which operate as spray-catchers. Two 12-in vapour lines from the dephlegmators combine into a 20-in header which enters a 10-ft by 70-ft fractionating tower, containing 26 trays, above the second tray. The vapours rise through trays 3 to 10, where they enter a chimney, by-passing a four-plate steam stripping section (trays 11, 12, 13, 14). From the down pipe of tray 15 a 6-in bootleg connexion returns reflux, regulated by a temperature control valve, to tray 10. This temperature control maintains the final boiling-point of the spirit at 205° C. The bottoms of the 4th tray steam-stripping section, that is, tray no 11, are drawn off through a float control valve and a cooler to the white-spirit tanks. The vapours passing through tray 15 flow through trays 16 and 17 into another short chimney which by-passes a 3 ft 3 in accumulating section just under tray 18.

The vapours from this point pass through trays 18, 19, 20, 21, 22, 23, 24, 25, and 26 to the top of the tower. In

each down pipe of the trays 19, 21, 23, and 25 and close to the weir box in the tray below are draw-off lines for tray cuts, which pass to a single surge tank.

The following are the boiling ranges of the products obtained from the column:

	I B P	F B P
Tops	40° C	160° C
White spirit cut	150° C	205° C
Tray draw-off cuts		
Tray 19	115° C	180° C
" 21	110° C	170° C
" 25	100° C	160° C

The redistillation of the cuts obtained in the above type of plant can be performed either in continuous or in batch stills, the latter being used where small quantities of material are dealt with or where several fractions are required in the redistillation. For some markets, however, the above white spirit would be sufficiently closely fractionated.

Redistillation by the Continuous Method

The crude spirits obtained in the primary distillation are produced continuously and may be fed directly into another fractionating column via the necessary reheaters with possibly only a surge tank separating the two units. In most cases, however, this interlocking is not desirable, so the surge tank gives place to a main storage tank and

the plants become completely independent units.

The secondary distillation by the continuous method may be effected by plant of varying type, but the particular design adopted will depend on various factors such as the quality of the crude cut and the specification of the required products. Three different plants will be described to illustrate current practice in this connexion.

1. Continuous Steam Still operating at Atmospheric Pressure.

This plant (Fig 2) was designed for the purpose of producing white spirits and spirits with a boiling-point range of the order of 20° C. In the distillation of white spirits in a plant of this type the provision of adequate preheating facilities is of first importance, whilst in the distillation of the lighter close boiling-point range fractions the provision for reheating in the second column is the major factor. The following is a description of the plant.

Columns. There are two columns each having a welded shell 48 in diam by 38 ft high. The bottom head is welded

to the shell whilst the top head is flanged and bolted. Each column has 22 removable bubble-cap trays, complete with drain holes and reflux pipes. Each cap has three rows of holes at different heights, the lowest being brought into use at maximum throughputs. The minimum height of liquid

Second Preheater

Heat transfer area	40 sq ft
Length of tubes	36 in
Diameter of tubes	$\frac{1}{2}$ in O D
Passes in tubes	6
Passes in shell	2

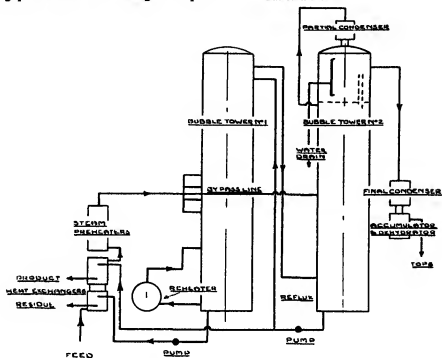

FIG 2

is $2\frac{1}{2}$ in. Each tray is provided with a thermometer pocket and tapped boss for sample cock, and a fixed weir forms a sump for the reflux. No 2 column, which carries a reflux condenser, is also fitted with a reflux head, in the form of a blank tray fitted above the top bubble tray. Two reflux down-takes are arranged from this tray to provide sufficient liquid height for the efficient separation of water from the spirit, the latter being withdrawn automatically by an external drain. Each column is provided with a live steam coil above the liquid-level at the bottom of the column, and a float-level controller. The columns are lagged with 2-in. magnesia composition and asbestos mattresses covered with galvanized sheeting.

Heat Interchangers. These are two in number, and have the following specification

	1	2
Heat transfer area	35 sq ft	175 sq ft
No of passes in tubes	4	20
No of passes in shell	4	20
Material of tubes	Admiralty	Admiralty
	Bronze	Bronze
Length of tubes	18 $\frac{1}{2}$ in	18 $\frac{1}{2}$ in
Diameter of tubes	$\frac{1}{2}$ in O D	$\frac{1}{2}$ in O D

In normal operation no 1 is coupled with no 1 column and no 2 coupled with no 2 column, but these can be reversed should the ratio of the products from each column change.

First Preheater

Heat transfer area	70 sq ft
Total number of tubes	248
Length of tubes	18 $\frac{1}{2}$ in
Diameter of tubes	$\frac{1}{2}$ in O D
Material of tubes	Admiralty bronze
No of passes in tubes	8
No of passes in shell	1

Third Preheater

Heat transfer area	65 sq ft
Total number of tubes	176
Size of tubes	$\frac{1}{2}$ in O D
No of passes in tubes	12
No of passes in shell	1

Reboiler No 1 Column

Heat transfer area	210 sq ft
Total number of tubes	470
Size of tubes	$\frac{1}{2}$ in O D
No of passes in tubes	2
No of passes in shell	1

Partial Condenser

Heat transfer area	120 sq ft
Total number of tubes	328
Length of tubes	24 $\frac{1}{2}$ in
No of passes in tubes	8
No of passes in shell	1

Final Condenser

Heat transfer area	300 sq ft
Total number of tubes	820
Length of tubes	24 $\frac{1}{2}$ in
No of passes in tubes	20
No of passes in shell	1

Dehydrator. It is 4 ft 10 in high, 3 ft in diameter fitted with an automatic water and spirit drain.

Pumps. The bottoms of no 1 tower are circulated through the reboiler by a 3-in turbine-operated centrifugal pump.

The feed and the bottoms of each tower are pumped by three or four pumps, size $4\frac{1}{2} \times 3\frac{1}{2} \times 4$ in. The two pumps for the column bottoms are operated by $\frac{1}{4}$ -in motor valves controlled by the floats in the base of the columns the feed pump is controlled by hand. The fourth pump is a standby.

Operation of the Plant. The crude spirit to be distilled is drawn from a storage tank of 500 tons capacity and pumped via the residue-crude exchanger and the product-crude heat exchangers to the three steam-heated preheaters. The amount of steam supplied to these is regulated by means of a temperature controller of the vapour-pressure type with air-operated relay, and the vapour-liquid mixture passes at the required temperature to either the first or second column. If the crude white spirit has to be split into three fractions both columns are required, but if the crude has to be topped only, then the second column is used. In the first column alternative feed supply to 4 trays is provided (the 11th, 13th, 15th, and 17th, counting from the top). Normally the feed is taken to the 11th tray and the liquid falls to the 22nd tray and thence to the bottom of the column. The bottoms of the column are recirculated by means of the centrifugal pump to the 20th tray through the reboiler. There is a temperature control fitted in the spirit-return line to the column from the reboiler which controls the amount of steam being fed to the reboiler and so maintains the bottoms of the column at the required temperature. The vapours ascend the column and pass through a vapour line to the base or the middle of no. 2 column. The reflux is provided by the product pump of no. 2 column in the delivery line of which is fitted a control valve operated by the temperature relay at the top of no. 1 column, enabling the top of no. 1 column to be kept at a definite temperature, which temperature controls the final boiling-point of the white spirit obtained at the base of no. 2 column. The stripping of the bottoms of no. 1 column is aided by live steam, which is provided through a perforated pipe situated above the liquid-level in the base of no. 1 column. The percentage of bottoms obtained in crude white spirit distillation is a very variable quantity and may be as low as 1%, but it is generally desirable to obtain a good separation between white spirit and residues since the residues should have a flash-point of 150° F. The vapours from the top of no. 2 column pass to the partial condenser in which both water and spirit are condensed and fall to the blank tray at the top of the column from which the water is withdrawn by an external drain. The amount of reflux used is controlled by means of a by-pass valve fitted across the inlet and outlet water-supply lines to the partial condenser, the valve being operated by the temperature relay from the top of no. 2 column. By this means the initial boiling-point of the white spirit is controlled. The vapours remaining uncondensed after passage through the partial condenser are led to the top of a final condenser, water-cooled, and the condensate gravitates to the automatic water and spirit separator.

Operating Data. For each given crude white spirit and for each different grade of product required, there will be different optimum conditions, which have to be explored for each individual case and sometimes involve modification of the plant. The following particulars are given to illustrate the production of 98° F. flash-point white spirit from a crude white spirit

Analysis of Intake

Specific gravity at 60° F		0.785	
Flash-point (closed)		85° F	
<i>Distillation</i>			
<i>I B P</i>	10%	20%	30%
149° C	154° C	157° C	158° C
	60%	70%	80%
166° C	169° C	173° C	180° C
		90%	<i>F B P</i>
			197° C

Plant Conditions

	98° F white spirit
Throughput tons per hr	4.5
Temperature crude to column	159° C
" " No. 1 Vapour Line	148° C
" " No. 2 " "	113.5° C
" " No. 2 " "	168° C
" " No. 2 " "	149° C
" " Bottoms to reboiler	169° C
" " from reboiler	172° C

In starting distillation, steam is turned on the preheaters and the column, the feed pump is then started, and after 1½ hours the product is obtained, and after a further 2 hours steady conditions have been established.

Analysis of Products

98° White Spirit			
	Tops	98° F W S	Residue
Specific gravity	0.775	0.792	0.818
Flash-point (closed)		100° F	152° F
<i>Distillation</i>			
<i>I B P</i>		156° C	196° C
<i>F B P</i>	162° C	189° C	10 ¼/200° C

Yields

Tops	18.6%
98° white spirit	80.5%
Residue	0.9%

Steam Consumption. The still requires 1,250 lb of steam per hour as live steam and 4,000 lb per hour as total steam. Of the 1,250 lb per hour of live steam 860 lb are used in the preheater and 390 lb in no. 1 column.

Reflux Ratios. When operating the plant on a crude containing only 1% of residue, no reflux is used on the first column, whilst on the second column the reflux ratio used is of the order of 8.

2. Pipe Still operating under Slight Pressure.

Fig. 3 illustrates a plant [4, 1927], in which kerosene is treated for the production of a heavy naphtha top, a white spirit, and a gas-oil residue. It consists essentially of two pipe stills connected with two bubble-cap towers and two heat exchangers. The diagram indicates the lay-out.

The crude kerosene intake is split into two streams, one of which exchanges heat with the residual gas-oil bottoms and the other with the vapours from no. 2 bubble tower. These two preheated kerosene streams then combine and are charged into the first bubble tower, where they flow down over the plates and are stripped of the heavy naphtha content. The hot oil is then led back into the first compartment drum, which acts as a reservoir. This material is then charged through no. 1 pipe still and into the other compartment of this same drum, where evaporation takes place. The vapours enter the base of the column and the heavy naphtha vapours are taken overhead and condensed. A portion of this condensate is pumped from the reflux drum on to the top tray of the bubble tower to furnish the necessary reflux. The tower is operated under about 20-lb pressure, the pressure being controlled by means of the valve on the rundown line from the reflux drum.

The kerosene with the heavy naphtha removed is then charged into no. 2 bubble tower, where the white spirit is removed. The arrangements on the back-trap drum and pipe still of this second tower are similar to those on the first tower. The white-spirit vapours are sent through a vapour-heat exchanger before entering the condenser and the reflux drum. It is found necessary to operate no. 2 bubble tower at a pressure about 5 lb, lower than no. 1

bubble tower The residual gas-oil fraction is drawn out of the compartment drum through the bottoms heat exchanger and delivered to storage.

The pipe stills are of the conventional type, and the plant handles 1,700 bbl of kerosene per day

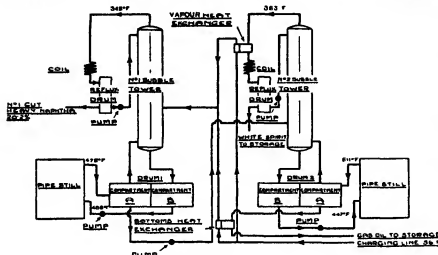

FIG. 3

Plant Operating Data

Yield	Intake		
	20 2% heavy naphtha	19 9% white spirit	59 8% gas oil bottoms
Sp gr at 60° F	0 820	0 776	0 803
Distillation			
1 B P	134° C	116° C	155° C
10%	151° C	121 5° C	157° C
20%	166 5° C	125 5° C	160 5° C
30%	181° C	129° C	162° C
40%	193 5° C	132° C	164 5° C
50%	205° C	134° C	165° C
60%	218° C	137° C	165 5° C
70%	231° C	140° C	166 5° C
80%	248° C	146° C	170° C
90%	273° C	150 5° C	175° C
F B P	327 5° C	164° C	184° C
Recovery	98 5%	98%	98%

The fuel consumption is 2.3% by volume. It is possible to obtain a gap between the heavy naphtha and the white spirit if this is required.

3. Vacuum Still for Cracked Naphthas.

It has been determined that the decomposition of acid compounds formed in treating cracked naphthas increases rapidly above 275° F. The following plant [5, 1932] was erected to redistill 7,000 bbl per day of heavy, cracked naphthas, having an initial boiling-point of 275–325° F (135–163° C). The maximum temperature of the oil in the column was specified at 275° F. The plant consists essentially of a vacuum tower 16 ft. in diameter, with a steam pre-heater, a partial condenser, a side column with recycle cooler, a tubular residue-to-intake heat exchanger, and barometric condensers. The lay-out of the plant is as follows:

The vacuum tower is fitted with six fractionating and two stripping trays and is equipped with internal heaters and reboilers. The heaters and reboilers consist of tubes within a trough. Steam is used through the tubes and the heavy naphtha gravitates from the upper trays outside the

tubes, overflowing a weir at the end of the trough. The intake is the bottoms from the atmospheric steam stills, which are treated, when necessary, with acid and neutralized with caustic soda. The feed exchanges heat with the vacuum-still residue in a tubular heat exchanger and is then passed through a steam preheater, before entering the tower at the second fractionating tray at a temperature of approximately 71° C., at which temperature no vaporization of the feed takes place. The absolute pressure on the dry line is 53 mm., and the pressure at the bottom of the column is 60 mm. The small pressure-drop indicates the excellent design of the bubble trays and partial condenser.

The oil after entering the tower is heated to 130° C by means of steam flowing through internal tubular heaters located in troughs on the second tray, whilst the final heating of the bottoms before leaving the tower is accomplished with two internal reboilers on the bottom tray of the tower. The temperature at the base of the column is 135° C.

The vapours leave the column at a temperature of 101.5° C and enter a partial condenser, having its tubes so arranged as to ensure a constant velocity through them. Under these conditions the pressure differential between inlet and outlet is only 1–2 mm. The liquid and gas are separated in a side column which has a vertical baffle. The liquid drops to the base of the column and is cooled to 32° C and pumped to the top of the column. This liquid acts as an absorption medium for the uncondensed vapours from the partial condenser, with the result that the loss is only 0.5 to 1.0% in the distillation. The product is withdrawn from a collecting tray in the side column and pumped to storage. The side tower and recycle cooler could be eliminated by increasing the tube area of the partial condenser so as to obtain a temperature equivalent to that of the finished gasoline leaving the side tower. At the time of erecting the plant the heat-transfer rates in partial condensers operating under a vacuum were indefinite. In operation a 'K' value of approximately 125 is obtained in the partial condenser. The recycle is not withdrawn from the tower, but is permitted to rise until the naphtha flows over the baffle on to the collecting tray. The tower is refluxed with the finished product at a rate of 0.35 pt reflux to 1 pt of product. A vacuum as low as 15 mm can be obtained.

Data for runs on steam still bottoms are given in Tables I and II. Test runs have also been made of vacuum distillation of the pressure distillate bottoms from debutanizers. Feed stock from the latter has an initial of 65–71° C with a maximum of 1% by volume of butane. The object of this test was to determine the economical value of processing this stock directly in a vacuum still. The flow of the feed and products is essentially the same as when operating on steam still bottoms.

Redistillation by the Discontinuous Method

Batch Still Distillation.

Batch still distillation involves much more supervision and more frequent sampling than is the case with a con-

TABLE I
Plant Data for Steam Still Bottoms

	Feed	Overhead	Bottoms
Sp gr at 60° F	0.809	0.805	0.844
Flash-point	110° F	170° F	98° C
Colour	2 N P A	28 Saybolt	6 N P A
Distillation			
I B P	158° C	153° C	203° C
10%	167° C	163° C	206° C
20%	171° C	167° C	212° C
30%	175° C	171° C	215° C
40%	180° C	174° C	219° C
50%	184° C	178° C	223° C
60%	187° C	181° C	227° C
70%	190° C	184° C	238° C
80%	197° C	188° C	243° C
90%	205° C	194° C	254° C
F B P	240° C	206° C	320° C

Operating Conditions

Temperatures		
Feed from storage		39° C
" " exchanger		60° C
" " preheater		74° C
Bottom of tower		135° C
Reboiler		134° C
Heater		127° C
Tray no. 5		118° C
Tower top		98° C
Steam		193.5° C
Partial condenser outlet		46° C
Vapour from partial condenser		39° C
Dry line		38° C
Spirit to cooler		39° C
" from cooler		32° C
Bottom of tower		134.5° C
" from exchanger		66° C
Bottom of cooler		47° C
Water from spirit cooler		30.5° C
" " reflux "		34.5° C
" " recycle cooler		39.5° C
" " bottom "		31.5° C
" " partial condenser		50° C
Fresh water		31° C
Water from 1st barometric condenser		31° C
" " 2nd "		34° C
Condensate from heater		147° C
" " reboiler		142° C
Absolute pressures		53 mm
Reboiler		61 "
Heater		59 "
Partial Condenser inlet		55 "
" " outlet		53 "

TABLE II
Plant Data for Distillation of Debutanized
Pressure Distillate

	Feed	Overhead	Bottoms
Sp gr at 60° F	0.7835	0.770	0.8398
Flash-point			148° F
Colour	10 Saybolt	30 Saybolt	8 N P A
Distillations			
I B P	70° C	68° C	193° C
10%	104.5° C	101° C	199° C
20%	119° C	111° C	201° C
30%	130° C	123° C	204° C
40%	140° C	131° C	206° C
50%	151° C	140° C	210° C
60%	163° C	146° C	214° C
70%	175° C	156° C	218° C
80%	186° C	170° C	223° C
90%	199° C	184° C	233° C
F B P	229.5° C	222° C	

Operating Conditions

Temperatures		
Feed to heat exchanger		39° C
" from heat exchanger		58° C
" from preheater		69° C
Reboiler		98° C
Heater		132° C
Tower top		99° C
Partial condenser outlet		36° C
Absolute pressures		
Dry line		104 mm
Tower top		103 "
" bottoms		117 "

tinuous still. In addition, batch still fuel and steam consumptions are considerably higher. In spite of these disadvantages, however, the method is still very largely employed to-day on account of its great flexibility in operation. Various methods of heating may be employed and distillation may be effected at atmospheric pressure or under vacuum.

Distillation with Steam at Atmospheric Pressure.

The essential features of this type of plant are well known, and the following is a particular specification

Still	Average inside length	26 ft 10 in
	Inside diameter	9 ft 10½ in
	Total capacity	55.66 tons water
	Working capacity	42.11 " "
	Thickness of side plates	½ in
	" " end "	½ in
	Size of manhole	15½ in
	" " oil inlet	4 in
	" " residue inlet	4 in
	No. of closed steam coils	3
	Total no. of lengths of pipe to coil	48
	Total length of pipe	1,238 ft
	Size of pipe	2½ in O D
	Effective heating surface	729 sq ft
	Details of closed steam outlet lines	3, 1 in
	No. of open steam lines	1, 1 in
	No. and size of perforations on open steam lines	50 staggered, ½ in

The still is lagged with 2½ in of 85% magnesia composition and metal sheathed. It carries 2 gauge glasses, 1 thermometer pocket, 1 combined vacuum pressure gauge, and 1 safety valve set to blow at 10 lb per sq in.

Fractionating Column. The column is mounted directly on top of the still and contains a series of horizontal perforated trays. The perforations are fitted with collars on the upper side, and these collars are covered with caps

Details

Height of column	18 ft 8 in
Internal diameter	5 ft 3½ in
No. of trays	2 in
Depth of trays	½ in
Thickness of plate	½ in
Thickness of trays	½ in
Distance between trays	7 in
No. of capped perforations on each tray	46
Total no. of capped perforations	1,380
Diameter of perforations	4 in
Height of collars	2½ in
Inside diameter of collar	3½ in
No. and size of distillate outlet pipe between trays	1, 8 in on alternate 4, 4 in trays.
Size of vapour outlet	10 in
Size of distillate return from dephlegmator column	7 in

WHITE SPIRITS, SPECIAL NAPHTHAS, AND PETROLEUM SOLVENTS, BY DISTILLATION 1667

The column is lagged with 2½ in. of 85% magnesia composition

Dehlegmator. The dehlegmator is of the vertical tubular type, water flowing through the tubes and vapour through the shell Details

Length over end angle faces	13 ft 1 in
Inside diameter	3 ft 3 in
Thickness of shell	½ in
Size of vapour inlet top	10 in
" outlet bottom	7 in
Size of distillate return (bottom)	7 in
" water inlet (bottom)	3 in
" outlet (top)	4 in
Baffles	Nil
No and size of tube plates	2, ¾ in thick
No of tubes	221
Diameter of tubes	1½ in
Overall length of tubes	10 ft 3½ in
Distance between plates	10 ft 1 in
Effective cooling surface of tubes	902 sq ft
Lagging—85% magnesia composition	

The reflux return line from the dehlegmator to the column is fitted with a drain cock at the bottom of the U-bend

Condensers Vertical tubular type, water through tubes, vapour through shell Details

Length over end angle faces	19 ft 8½ in
Inside diameter	2 ft 7 in
Thickness of shell	½ in
Size of vapour inlet (top)	7 in
" distillate outlet (bottom)	4 in
" water inlet (bottom)	3 in
" outlet (top)	4 in
No and type of baffles inside shell for baffling vapours	4 transverse covering ½ section
No and size of tube plates	2, ¾ in thick
No and type of tubes	128 swelled one end
Diameter of tubes	1½ in O D
Thickness of tubes	½ in
Overall length of tubes	17 ft 1½ in
Length of tubes between plates	17 ft 0½ in
Effective cooling surface	832 sq ft

Operation of Plant The still is charged with the spirit to be distilled, and after the steam coils are covered with spirit the steam is turned on and a careful watch is kept on the temperature. When the still approaches the distillation temperature of the charge, the steam is reduced to give the required rate of distillation, and the water on the dehlegmator is adjusted to give the required reflux ratio. To assist the distillation of the components of higher boiling-point, live steam is admitted to the still when the temperature has reached 150° C. In routine distillations, the rates of distillation and reflux are fixed and the distillation can be controlled and the cuts made on the results of hourly determinations of the specific gravity of samples drawn from a sight glass through which the distillate from the condenser flows on its way to a manifold header from which it may be allowed to pass to any required tank. In special cases the cutting from one grade to another may be determined by the distillation test of the sight-glass sample or of a sample from the distillate receiver

Operating Data. The following is the log of a still run when producing 98° F flash-point white spirit from a crude white spirit

Time	Still Temp ° C	Steam press lb sq in	Temperature of		Sp gr at 60° F	Running to tank
			Cooler water, ° C	Distillate ° C		
3 00	158	142	22	22	0.754	38
4 00	160	142	24.5	24.5	0.760	38
5 00	162	142	26	26	0.764	38
6 00	164	144	25.5	25.5	0.768	38
7 00	164	150	24	24	0.768	38
8 00	166	138	25.5	25.5	0.769	38
9 00	167	140	25	25	0.769	38
10 00	167	136	25	25	0.770	23
11 00	169	140	25	25	0.770	23
12 00	170	138	31.5	31.5	0.777	23
13 00	170	140	35	35	0.779	23
14 00	169	140	36	35	0.781	23
15 00	169	138	36.5	36	0.781	23
16 00	170	142	36.5	36.5	0.782	23
17 00	170	144	27	25.5	0.782	23
18 00	170	147	30	30	0.782	23
19 00	171	150	30	30	0.783	23
20 00	172	146	27	27	0.783	23
21 00	172	136	31.5	26	0.784	23
22 00	172	142	31.5	24	0.784	23
23 00	172	140	29.5	29.5	0.785	23
24 00	170	142	31	29.5	0.786	23
1 00	170	140	31.5	26	0.787	23
2 00	171	141	31.5	26	0.788	23
3 00	172	142	31.5	25.5	0.789	23
4 00	170	140	30.5	26.5	0.791	23
5 00	169	138	30.5	26	0.792	23
6 00	171	142	31	26	0.793	23
7 00	172	140	30.5	25	0.794	23
8 00	172	140	29.5	24.5	0.796	23
9 00	172	146	30	24.5	0.797	23
10 00	170	140	29.5	24.5	0.798	23
11 00	170	146	29.5	24	0.800	23
12 00	170	134	30	24	0.801	23
13 00	170	142	30	25	0.802	23
14 00	170	140	30	25	0.803	23
15 00	170	144	30	24	0.803	23
16 00	167	136	30.5	24.5	0.805	23
17 00	165	140	31	25	0.806	23
18 00	165	147	31	25	0.807	23
19 00	164	140	31.5	25	0.807	23

Analysis of Tank 23 flash-point, 100° F, distillation I B P 154° C, F B P 188° C

The rate of distillation is approximately 0.75 tons per hour using a reflux ratio of the order of 1.5. The steam used in distillation, the total live steam and distillation steam, amounts to 0.6 tons steam per ton of throughput (Fig. 4)

Hot Oil Distillation.

In some instances it is possible to utilize hot oil from an adjacent plant in place of steam for the distillation of white spirits. This has the advantage of saving the steam previously used for distillation of the white spirits and the water previously used for cooling the hot oil. It may provide a higher temperature than steam, but dependence on an adjacent plant is frequently undesirable.

Vacuum Distillation.

Batch stills of the sort described may be operated under a vacuum of some 60 cm for the production of white spirit in the following manner. The white spirit receivers and the lines to them from the stills are made as gas-tight as possible and the vacuum lines are taken from the tops of the receivers to a vacuum pump. The discharge from the vacuum pump passes through a cooler before discharging into a small tank containing baffles to trap condensed benzene. The still is charged and closed steam is opened up carefully until the distillation starts. The initial rate of

distillation is 1-1½ tons per hour. Water is put on the dephlegmator, and the distillation is continued at this rate until the white spirit fraction is reached. The rate of distillation is then increased to 2 tons per hour, and when the distillate has an average boiling-point of 140° C a vacuum is put on the receiver. This vacuum is about 20 cm to start with and is gradually increased during distillation to a maximum of 60 cm Hg towards the end of the distillation. Open steam is not used until it is necessary to maintain the rate of distillation.

The loss of benzene using vacuum during the distillation is negligible, and very little is condensed from the vacuum pump exhaust.

Batch stills may also be operated under a slight vacuum, where the stills have had the seams welded and the stills themselves have been braced to meet the conditions, by operating a closed system as in the following instance:

The still is fitted with a fractionating column and the vapours are condensed in two water-cooled tubular condensers working in parallel, the condensate flowing through a common rundown line to a surge tank. The surge tank is fitted with a water run-off and a constant water-level is maintained by the balanced head principle. Two pumps driven by a steam engine through a common shaft take suction on the surge tank through a common suction line. One pump delivers the spirit required for reflux, whilst the second discharges the product through a 'cool in tank' type final cooler to the sight glass. Both pumps are fitted with a variable stroke control so that the reflux ratio can be controlled over wide limits. The system at the beginning of the distillation is vented at the condenser outlet to allow non-condensable gases to pass to the scrubber. When these gases have been removed the vent is closed, and the result is a closed system up to the surge tank placed at ground-level. A vacuum is then developed which gradually increases as distillation proceeds, reaching about 15 in mercury towards the latter part of the distillation.

The Refining of White Spirits

The principal object of refining white spirit is to obtain a spirit of good odour which is free from sulphur compounds, since sulphur compounds, if present, may darken such paint pigments as lead salts and metallic powders.

The sulphuric acid and caustic soda method of refining is still the most widely used process, and the plant employed may be batch or continuous agitators. Since white spirits are handled in relatively small quantities, the batch method is employed almost exclusively. In batch treatment a quantity of white spirit is fed into an agitator and there mixed with a measured quantity of refining agent. Mixing is effected either by stirrers or by circulating, and, after a definite reaction time, the spent reagent is withdrawn.

The agitators commonly used vary in size from 15 to 200 tons capacity. They are usually of cylindrical shape with cone-shaped bottoms and are lined with chemical lead.

The following is the programme for the refining of a particular white spirit in an agitator of 15 tons capacity, fitted with stirrers of the typhoon type

	Time of agitating (min)
1st sulphuric acid 15% (98.4%)	20
Settle and drain	15
2nd acid, 15%	20
Settle and drain	15
Water wash	10
Settle and drain	15
Water wash	10
Settle and drain	15

	Time of agitating (min)
Water wash	10
Settle and drain	15
1st caustic soda 15% Be soln 0.025%	20
Settle and drain	15
2nd caustic soda 15% Be soln 0.025%	20
Settle and drain	15
Water wash	10
Settle and drain	15
Water wash	10
Settle and drain	15

In some cases it may be necessary to extend the sulphuric acid treatment to 3-4% in three or more treatments. During the refining the final boiling-point of the white spirit usually rises a few degrees, and this fact must be remembered when preparing white spirits to a final boiling-point specification.

Special Naphthas and Petroleum Solvents

Special naphthas and petroleum solvents may be prepared by distillation in the same type of plant as has been described for the preparation of white spirits. In view, however, of the fact that these solvents are generally produced in much smaller quantities than is white spirit, and that from a distillation a greater number of fractions are segregated, the batch still method of production is that most frequently adopted. For such products the selection of basic material is a matter of great importance and generally turns on the aromatic content of the crude benzene. Aromatic hydrocarbons occur in most crudes but generally in small amounts. Certain crudes, on the other hand, contain relatively large proportions of aromatic hydrocarbons. Chavanne and Simon [1, 1919] examined Borneo benzene and claim to have identified cyclopentane, methyl cyclopentane, cyclo-hexane, &c. Tizard found the composition of the benzene fraction of Koetzi oil to be paraffins 26%, naphthenes 35%, and aromatics 39%. The separation of toluene from Borneo benzene [3, 1921] was effected on a large scale in England and France during 1914-18.

When the objective is the preparation of a product of high solvent properties, a basic material rich in aromatics will be selected, the distillation being conducted so as to concentrate aromatic hydrocarbons in the product, and subsequent chemical refining processes being used which will have as slight a tendency as possible to remove aromatic bodies. When, on the other hand, it is desired to segregate a product with low or even zero aromatic content, a basic material as free as possible from aromatics will be chosen, and a chemical refining process will follow which is definitely designed to leave no aromatics in the final product. A product of this sort is Sludge Testing Spirit, used in the determination of the sludging value of transformer and switch oils.

High Aromatic Content Spirits

A typical intake would be a crude benzene of the following analysis:

Distillation	Specific gravity at 60° F					Aromatics
	10%	20%	30%	40%	50%	
I B P	10%	20%	30%	40%	50%	0.7915
61° C	93° C	102° C	107° C	113° C	119° C	.36%
60%	70%	80%	90%	F.B.P.		
125° C	133° C	141° C	152° C	173° C		

from which the following products might be prepared:

WHITE SPIRITS, SPECIAL NAPHTHAS, AND PETROLEUM SOLVENTS, BY DISTILLATION 1669

	75-95 spirit	100-120 spirit	Rubber solvent	White spirit	60% 134.5° C	70% 146° C	80% 157° C	90% 171.5° C	F B P 197.5° C
Sp gr at 60° F	0.776	0.790	0.795	0.810					
Distillation					<i>Analysis of Distillate</i>				
I B P	75° C	101° C	114° C	155° C	I B P	10%	20%	30%	40%
F B P	94° C	117° C	157° C	178° C	61° C	75° C	78° C	81° C	84° C
									87° C

This distillation may be carried out on a batch still of the type previously described. The still is charged with the spirit to be distilled, and after the steam coils are covered with spirit the steam is turned on and a careful watch is kept on the temperature. When the still temperature approaches the distillation temperature of the charge the steam is reduced to give the required rate of distillation. The topping of the still and the preparation of the 75/95 boiling-point spirit is carried out at a very slow rate—the distillation proceeding at the rate of 0.14 ton per hour with a reflux ratio of 10. After the preparation of the 75/95 spirit the rate of distillation is increased to approximately 0.50 ton per hour, whilst the reflux ratio falls to 5. The rubber solvent is next collected, whilst the residues of more than one charge are subsequently distilled to obtain a white spirit. Care must be taken in the handling of special solvents, and, if common lines or pumps have to be used, the lines must be washed through with water and the spirit in the lines tested before being used to effect a transfer.

Low Aromatic Content Spirits

An example of such a product is to be found in the sludge testing spirit, which must conform to the following specification

- (a) Its specific gravity at 60° F shall not be over 0.700
- (b) When tested by I P T Method G 3, its I B P shall not be under 60° C, at least 75% by vol shall distil at 100° C, and its F B P shall not be over 120° C
- (c) Its iodine value (Hubl method) shall not be over 0.30%
- (d) When tested by I P T Method G 30 the percentage by weight of aromatic hydrocarbons obtained by multiplying the increase of the C S T by 1.19 shall not exceed 2% by weight. The C S T after treatment with 98-100% sulphuric acid shall not be below 58° C

This material would be prepared on a batch still of the type identical with that previously described from a crude spirit low in aromatics and the product given a refining with oleum

Analysis of Intake

Sp gr at 60° F.	0.730				
Distillation					
I B P	10%	20%	30%	40%	50%
45° C	78.5° C	94° C	106.5° C	116.5° C	123° C

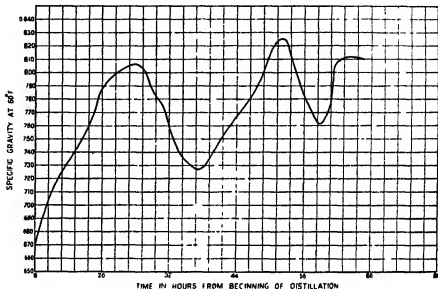

FIG 4 Specific gravity time curve for distillation of spirit of high aromatic content

60%	70%	80%	90%	F B P
90° C	92.5° C	97° C	102° C	102.5° C

Refining

1st wash	1% 98% sulphuric acid (for drying)
2nd "	5% oleum 20% strength
3rd "	" "
4th "	" "
Agitation period	½ hr each wash
Settling period	10 mins

The spirit then contained 0.18% aromatics and was given a further 5% oleum, which completely eliminated the aromatics. This treatment was followed by the usual water and soda washes, using 0.05% solid soda in a 15° Be solution

Analysis of Final Product

Sp gr at 60° F	0.6985				
C S T	62.4° C				
Aromatics	Nil				
Formolite reaction	Negative				
Distillation					
I B P	10%	20%	30%	40%	50%
63.5° C	76° C	79° C	82° C	85° C	88° C
60%	70%	80%	90%	F B P	
90° C	93° C	96.5° C	101° C	114.5° C	

Yields

From distillation	31.1%
Refined sludge spirit	23.4%

REFERENCES

1. CRAVANCE and SIMON *Comp Rend*, 285 (1919)
 2. GOODLAW, A H *Trans Inst Chem Eng* 12, 107 (1934)
 3. KARLEY, J. *J.I.P.T* 7, 209 (1921).
 4. KOCH, F C. *Oil and Gas J* 25, no 42, 135 (1927)
 5. NOLL, H D. *Oil and Gas J* 30, no 46, 66 (1932)

PRINTED IN
GREAT BRITAIN
AT THE
UNIVERSITY PRESS
OXFORD
BY
JOHN JOHNSON
PRINTER
TO THE
UNIVERSITY

DATE OF ISSUE

This book must be returned
within 3, 7, 14 days of its issue. A
fine of ONE ANNA per day will
be charged if the book is overdue

--	--

For Reference

—•••••—

NOT TO BE TAKEN FROM THIS ROOM