

BIRLA CENTRAL LIBRARY

PILANI (RAJASTHAN)

Class No. 691

Book No. T17B

Accession No. 31527

THE BUILDER'S MATERIALS

By the Same Author

PRACTICAL BUILDING MECHANICS

THE
BUILDER'S
MATERIALS

by

NEWMAN TATE

M.I.Mech.E., M.I.Struct.E., M.J.I.E., M.I.Loco.E.

Technical Director, Clarke Barton and Co., Ltd. Lecturer in Building Construction, Building Mechanics, Builder's Quantities, at Croydon School of Building. Sometime Lecturer in Strength of Materials, Theory of Machines, Mechanics, at Willesden Technical College. Sometime Lecturer in Strength of Materials, Technical Drawing, Engineering Science, at Leyton Technical College.



LONDON

CHAPMAN AND HALL LTD.

37 ESSEX STREET W.C.2

1947

First Published

1947



*This book is produced in complete
conformity with the authorized economy
standards*

Catalogue No. 329/4

PRINTED IN GREAT BRITAIN BY W. & J. MACKAY AND CO., LTD., CHATHAM
BOUND BY G. & J. KITCAT, LTD., LONDON. FLEXIBACK BINDING

AUTHOR'S PREFACE

AN attempt has been made to write this book in such a form as to make it interesting, and easily readable. It is not intended to be a specialist's book, but the material is technically sound and it should prove useful to students taking classes in which a knowledge of materials and the way they are produced is required. It is hoped the book will be interesting and useful to builders and engineers.

My thanks are due to the proprietors and the Editor of *The Illustrated Carpenter and Builder* for permitting me to use material from my articles which have appeared in that excellent journal.

I thank the publishers Messrs Chapman and Hall for the help they have given in the production and the suggestions they have made.

My thanks are due to Mr Colin Peter, A.M.I.M.E., for his help in preparing the drawings.

N.T.

November, 1946.

CONTENTS

I	FROM IRON ORE TO FINISHED PRODUCT <i>Iron and Steel—Classes of Iron Ores—Weathering of Calcined Ore—Effect of Sulphur—From Ground to Blast Furnace.</i>	I
II	BLAST FURNACE <i>Blast Furnace—Size—Material Charged in—Temperature—Gas—Hot Stoves—Layers—Blastpipe—Description of Operation of Blast Furnace—Impurities in Iron Ores—Analysis of Pig-iron—Coke—Limestone—Slag.</i>	7
III	CAST-IRON <i>From Pig-iron to Castings—Cupola—Kinds of Pig-iron—Graphite—Carbon—Malleable Cast-iron—Chilled Iron.</i>	16
IV	WROUGHT IRON PRODUCTION <i>Wrought Iron—Puddling Furnace—Balls and Blooms—Use of Wrought Iron—Effect of Heat-Strength.</i>	24
V	BESSEMER STEEL MAKING <i>Pig-iron to Bessemer Steel—Early Days—Converter—Effect of Impurities—Linings for Converters—Spiegeleisen—Ingots—Soaking Pits.</i>	30
VI	OPEN HEARTH STEEL <i>Open Hearth Steel—Siemens-Martin—Gases—Hearth-Lining—Silica—Dolomite—Stainless Steel—Chromium—Nickel—Classification of Carbon Steels.</i>	37
VII	ELASTIC PROPERTIES OF MATERIALS <i>Technical Terms—Stress—Strain—Modulus of E—Yield Point—Elasticity.</i>	47
VIII	LINTOLS AND BRESSUMMERS <i>Lintols—Bressummers—Load to be Carried—Bending Moments—Types of Lintols—Rolled Steel Joists—Flitched Beam—Reinforced Concrete.</i>	55
IX	LINTOLS AND BRESSUMMERS (continued) <i>Design of Lintols, using Rolled Steel Beams—Design with Concrete Strengthened with Tee-Irons—Design using Concrete Reinforced with Bars.</i>	62
X	COPPER <i>Copper—Furnace—Matte—Converter—Methods of producing Refined Copper—Electrolytic refined Copper—Paling—Pitch—Effect of Alloying with Zinc—Brass—Bronze.</i>	71
XI	LEAD, ZINC, NICKEL, CHROMIUM <i>Iron Perrons—Metals—Galena—Discovery of Lead—Furnace—Matte—Solder—Red Lead—Litharge—Zinc—Nickel—Chromium.</i>	79

XII	TIN, ALUMINIUM, TUNGSTEN	86
	<i>Tin, Properties of—Tin-foil—Malleability—Cry of Tin—Reverberatory Furnace—Pickling Sheet before Tinning—Aluminium—Symbols for Various Metals.</i>	
XIII	CEMENT MAKING AND CONCRETE	93
	<i>Cement Making—Wet Process—Kiln—Gypsum—Kinds of Cement—Ordinary Portland Cement—Rapid Hardening Portland Cement—High Alumina Cement.</i>	
XIV	PLASTIC, WOODWOOL, FIBRE-GLASS	100
	<i>Light Weight Concrete—Woodwool—Glasswool—Plastics—Terra Cotta—Slag Wool—Stoneware.</i>	
XV	REINFORCED CONCRETE	107
	<i>Reinforced Concrete—Tensile Strength—Why is Concrete Reinforced?—Stresses used in Reinforced Concrete Design—Grip Strength—Arrangement of Bars—Types of Columns—Effect of Mix on Water-tightness of Concrete.</i>	
XVI	LIMES AND PLASTERS	116
	<i>Limes and Plasters—Rich Limes—Mortars—Lime Mortar, Cement Mortar—Impurities in Limestone—Quicklime—Hydraulic Limes—Plaster of Paris—Keenes Cement.</i>	
XVII	BRICKS	124
	<i>Bricks—Wirecuts—Famous Brick Buildings—Different Clays—Pug Mill—Sand Lime Bricks—Colour of Bricks—Refractories—Analysis of Fireclay Bricks—Chrome—Segar Cones.</i>	
XVIII	COAL	133
	<i>Origin of Coal—Peat—Lignite—Bituminous Coal—Ash-Content—Heat Value—Coal Tar—Benzol—Town Gas—Ammonia—Dyes.</i>	
XIX	TIMBER	141
	<i>Protection of Timber—Dry Rot—Moisture Content—Creosote—Star Shakes—Timber—Hardwoods—Soft Woods—Faults in Timber—Strength of Timber—Decay.</i>	
XX	STONE	153
	<i>Stone—Oldest Stones—Igneous Rocks—Metamorphic, Sedimentary or Aqueous Rocks—Quartz—Felspar—Tracing History in Stone—Roman Stone in London—Blarney Stone—Dakota Memorial in Granite—Protecting Stone.</i>	
XXI	GLASS	162
	<i>Glass and its Uses—Early Coloured Glass—Sound Insulation—Crown Glass—Resisting Fire.</i>	

LIST OF PLATES

	<i>page</i>
1 Iron Ore to Finished Products.	5
2 Iron Ore to Pig-Iron.	9
3 From Pig-Iron and Scrap-Iron to Castings.	19
4 Pig-Iron to Wrought Iron.	25
5 From Molten Pig-Iron to Bessemer Steel.	33
6 Open Hearth Steel.	39
7 Elastic Properties.	49
8 Lintel Beams. Safe Loads on Fitched Beams.	57
9 Lintols.	63
10 Copper Furnaces.	73
11 Non-Ferrous Metals : Lead, Zinc, Nickel, and Chromium.	81
12 Non-Ferrous Metals : Tin, Aluminium, Tungsten, etc.	89
13 Limes and Plasters.	95
14 Reinforced Concrete.	109
15 Cement.	119
16 Brick-Making.	127
17 Coal and Its Bye-Products.	139
18 Timber.	143
19 Stone.	155
20 Glass.	165

CHAPTER I

FROM IRON ORE TO FINISHED PRODUCT

*Iron and Steel—Classes of Iron Ores—Weathering of Calcined Ore—
Effect of Sulphur—From Ground to Blast Furnace.*

IRON AND STEEL

IN one of its many forms, iron is still the metal most used by the builder. It was most certainly well known to the Romans more than 2,000 years ago, and there is a good deal of evidence to show that in Egypt and Assyria man was using iron nearly twenty centuries before the Christian era began.

The Old Testament itself makes many references to the use of iron. We know that Tubal Cain was a forger of copper and iron. The Book of Deuteronomy records that the land of Canaan was a land whose stones were iron. In the same book the "iron furnace" is mentioned.

The Stone and Bronze Ages preceded the Iron Age, but as far back as 3,500 years ago iron was already beginning to displace the bronze in India and the Mediterranean. We know that during the Roman occupation of this country, iron was used, for every schoolboy is aware of the fact that Boadicea attached sharp scythes or cutting irons to the chariot wheels of the Britons when they opposed the Roman invaders.

It was not until about the fourteenth century that cast-iron was produced in England. It was first produced in Sussex on a very limited scale, as would be expected since wood fuel was used. Until the beginning of the eighteenth century, when industry moved to the North, as a result of coal and coke displacing wood as a fuel, Sussex remained the centre of iron industry in this country. In these later days a good deal of industry has returned to the South, and to many resident Southerners the sight of blast furnaces is familiar.

There are authorities who estimate that something like 5 per cent of the total substance of this earth is iron. Many rocks contain small quantities of it, but sometimes the ore, may contain as much as 60 or 70 per cent of iron. As a rule it is not an economical proposition to extract the iron from a mineral ore unless it contains more than 25 per cent of iron.

THREE CATEGORIES

The various iron ores are generally divided into three main categories :

1. *Hematite* (FeO_3) which exists in two forms, red and brown. Both forms are found in large quantities in this country and both exist as ferric ores (Fe_2O_3).

2. *Magnetic or magnetite ores* which are very largely found in Sweden. It is from these ores that the world-famous Swedish iron is made. These are ferrous ores (Fe_3O_4), and they contain the largest proportion of iron. There are very large quantities of this ore in the U.S.A. Red Hematites are easier to treat than the ferrous magnetites which are very hard and dense. It is for this reason that the red hematite ores are generally not roasted but treated direct in the blast furnace, while magnetite ferrous ores are calcined and weathered.

3. *Carbonate ore*, of which large deposits are found in the Midlands and the N.E. of England, and also in Spain. When pure, these Carbonate ores (FeCO_3) contain 40 per cent of iron. They are sometimes called the Blackband. Clay Iron Stone and Spathic ore, sometimes called the Blackband, are largely found round the Scottish coalfields and contain coal impurities. Clay Iron Stone comes from South Wales.

Coal is mined from the ground in a form which can be directly used. Iron is found as an iron-stone ore, is mixed with many other impurities and these must be removed before the iron itself can be used.

MINERAL ORES

Mineral ores are usually classified according to the form in which the iron exists. The Latin name for iron is *Ferrum*, and iron is usually denoted by the letters Fe. Every schoolboy knows that in chemistry, oxygen is denoted by the letter O. The ordinary form of rust is a chemical compound of iron and oxygen, and if ordinary iron is left in the air it will be attacked by the oxygen in the air, and will rust. In technical words we may say that ferrous oxide has been formed on the iron. There are three compounds of oxygen and iron : (1.) Ferrous oxide, in which there is a proportion of one atom of iron to one atom of oxygen ; this is written as FeO . (2.) Ferric oxide, which is a combination of two atoms of iron to three atoms of oxygen ; this is written as Fe_2O_3 . (3.) Magnetic oxide, which is made up of three atoms of iron to four atoms of oxygen, and is written Fe_3O_4 . In addition to the iron in the ore, there are impurities : phosphorus, silica, carbon, manganese, being the chief. Unfortunately the iron ore frequently contains other impurities such as arsenic, lead, zinc and copper.

When an element combines with oxygen to form a compound, it is said to be oxidised. Carbon and oxygen can be mixed to form a gas ; in fact, the burning of all coal is really the combining of the carbon in the coal and the oxygen in the air, and if we know the analysis of the coal it is not very difficult to find exactly how much oxygen must be passed through the coal in order to make it burn. We also know that air is a chemical mixture which contains roughly twenty parts oxygen to eighty parts nitrogen, that is, roughly speaking, air has four parts to one part of oxygen.

Some impurities in the iron ores are detrimental. Too much sulphur, for instance, in iron would make it brittle when red hot. In technical words it is said to be "red short." Too much phosphorous, however, will make iron and steel brittle "cold short." On the other hand, phosphorous makes metal run easier when melted, and the presence of phosphorous, therefore, helps in the making of smooth and clean castings. The quantity of phosphorous in the iron ore is very important, as it will have a large effect in deciding which process will be used if it is to be converted into steel. Because of this, iron ores are often divided into phosphoric and non-phosphoric.

We illustrate (*Plate 1*) the various processes by which iron ore is changed until it becomes a finished product in the form of grates, pipes, rails, beams, boiler plates, or any other of the thousand-and-one commonly used articles which are made of steel and iron.

Magnetite ores are very hard and dense, and in order to render them more open or porous, so that the gas in the blast furnace can get through easier these magnetite ores are calcined, or roasted. The red hematite (Fe_2O_3) ores contain 70 per cent of iron when pure, and as a general rule these are not very dense and fairly easy to smelt, so that they are not calcined by their first treatment in the blast furnace.

In later chapters we shall deal with each of these processes more completely, but at this stage it is desirable that a general picture should be obtained.

After the mineral has been calcined, it is sometimes taken direct to the blast furnace ; sometimes it is heaped on the ground and weathered. The purpose of this weathering is to wash out sulphur which has not been removed during the calcining process.

The first real smelting of the iron-stone takes place in the blast furnace. Here the mineral ore is converted into pig-iron, slag and gases. These blast furnaces are generally between 70 and 100 feet high and are really hollow cylinders of steel plates protected from the heat by a lining of thick firebricks. The iron-stone, fluxes and fuel are charged into the blast furnace at the top. Out of the bottom of the furnace comes the molten pig-iron ; a little farther up, the slag is run off, and the gases are taken off near the top of the blast furnace.

Detailed explanations of the workings of a blast furnace will be given later.

The molten slag is run into special ladles or wagons, which run on rail tracks, and are taken off and tipped on to the slag heaps. So far as iron is concerned, the slag is a by-product, but it is by no means all waste.

QUESTIONS ON CHAPTER I

What are the three principal categories of iron ores?

What percentage of iron would a pure carbonate ore contain?

What impurities are found in iron ore?

What effect does too much sulphur have on iron?

What is red shortness?

What is the purpose of weathering iron ore?

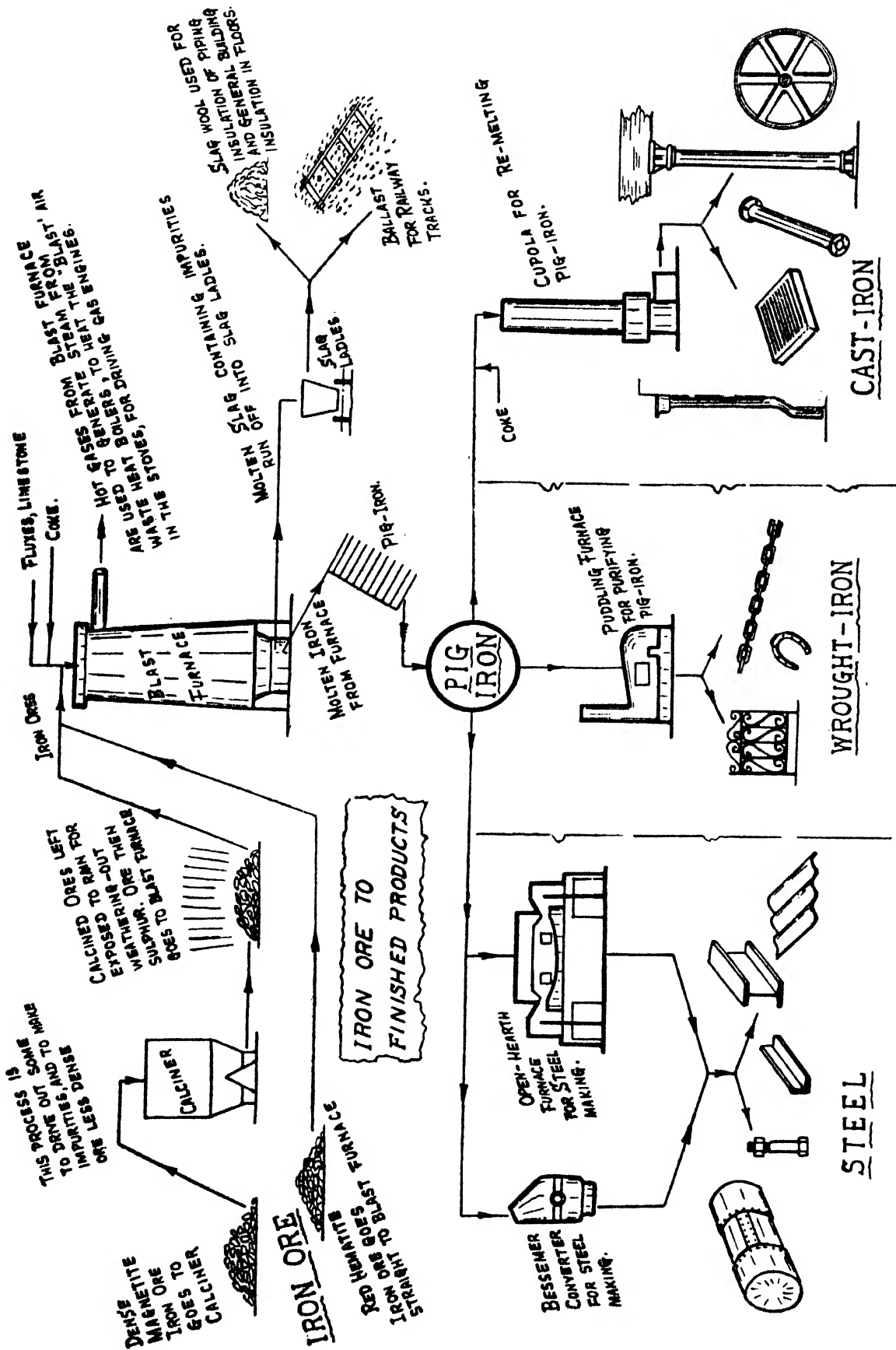

BLAST FURNACE

Blast Furnace—Size—Material Charged in—Temperature—Gas—Hot Stoves—Layers—Blastpipe—Description of Operation of Blast Furnace—Impurities in Iron Ores—Analysis of Pig-iron—Coke—Limestone—Slag.

IRON ore is a form of natural iron rust which is a combination of iron and oxygen. Earthy impurities exist in iron ore as mined and the job of a blast furnace is to separate the various impurities and produce pig-iron, which contains more than 80 per cent of pure iron. A blast furnace is a round cylinder made of steel plates and has a diameter of six or seven yards. The inside of the steel plates is protected from the intense heat by a thick lining of firebricks.

Starting at the bottom end of the blast furnace we have the hearth, a little higher up the furnace shell opens out, and this part is called the bosh; and from the top of the bosh to the top of the furnace the diameter gradually reduces, this part being called the furnace stack. (*Plate 2.*)

At the moment we will deal only with the blast furnace and the production of pig-iron. We shall split it up into four separate sections:—(1) What goes into a blast furnace; (2) What comes out of a blast furnace; (3) What takes place inside the furnace; and (4) Description of plant. Certain technical names will be used, and a short definition of these terms will now be given.

Slag.—The residue from the ore, which, being lighter than the metal, floats on top of the melted iron. It is really a *scum*. This slag residue is tapped off from a hole in the blast furnace, called a slag hole, which is higher than the hole from which the melted iron itself is run away.

Tuyeres.—The pipes through which the hot air is driven into the furnace.

Bosh.—This is the lower part of the furnace where the real melting and fusing and mixing up takes place. In this part of the furnace there is a mixing and conglomeration of materials which may be likened to the mixed up, unclear, statements which call forth the remark: "Don't talk bosh."

Flux.—As iron ores are generally mixed with other materials which require a very high temperature to melt them, it is necessary to add to the charge in the furnace something which will help in the fusion; for instance, silica

requires a higher temperature to melt it than is generally found in the blast furnaces ; but the silica must be removed from the iron, and when it is removed, it must be in the form of a liquid, so that it may be tapped from the furnace. To make this possible a flux, such as limestone, is added to the furnace. This, when heated, chemically combines with the silica, and the combination has a lower melting point than the temperature in the blast furnace. Whatever material is added to assist in lowering the melting temperature of the impurities in the iron ore (which have to be run off in slag) is called a flux.

Hot Stoves.—These are large cylinders lined with firebrick with special chambers. The hot gases from the blast furnace heat up the bricks in the stove to such a temperature that the cold air from the blowing engines is heated up as it passes through this stove on its way to the furnace.

Reducing and oxidising are common terms used in connection with the making of iron and steel. When oxygen is attached to some other element, the element is said to be oxidised. For instance, rust forming on iron is oxidisation of iron. In this case the oxygen in the air has attached itself to the element iron and produced rust, another name for which is iron oxide. When oxygen is removed from oxidised iron, we say it has been reduced. This reduction of the iron oxide causes metallic iron to form.

Three things go into a blast furnace, the iron ore, the coke and the flux. Iron ore is the only material which contains iron ; the coke serves as a fuel, and for the blast furnace work should be very hard and porous ; the limestone serves as a flux.

Most of the iron stones have impurities (called gangue) which are acid, and for this reason lime in the form of limestone is used as a flux. The exact amount of flux (and the material which should be used as a flux) depends upon the nature of the ore charged into the furnace.

At the base of the furnace the molten iron is tapped off into channels, sows and pigs, which are grooves formed in the sand. If the iron is to be made into steel, it is sometimes run direct from the furnace into ladles, which might be large enough to hold fifty tons. The ladles are carried by large overhead electric cranes, and the molten metal is emptied into a large drum called a metal mixer. We shall see what happens to it after that when we come to deal with the making of steel.

A little higher up the furnace molten slag is run off. This consists of the earthy impurities which were in the iron ore, the lime from the limestone, and the ash from the coke.

Iron ore, flux, and fuel (coke) are filled into a double bell hopper at the top of the furnace. Inside the furnace is a burning mass. At the top the

MATERIALS WHICH ARE PUT INTO BLAST FURNACE.

IRON ORE WHICH IS:- FERRIC OXIDE... Fe ₂ O ₃ . + SILICA... SiO ₂ + ALUMINA... Al ₂ O ₃ + SMALL QUANTITIES OF COMPOUNDS OF MANGANESE PHOSPHORUS, SULPHUR ETC. + MOISTURE	FLUX WHICH IS:- LIMESTONE CONTAINING LIME... CaO CARBON + DIOXIDE... CO ₂ .	FUEL WHICH IS:- COKE CONTAINING CARBON... C + ASH. + MOISTURE.
---	--	--

THIS IS WHAT TAKES PLACE IN THE BLAST FURNACE.

COKE BURNS, AND ITS CARBON (C) COMBINES WITH THE OXYGEN (O) IN THE HOT BLAST AIR TO FORM CARBON MONOXIDE (CO). THIS HOT GAS RISING IN THE FURNACE COMES IN CONTACT WITH THE FERRIC OXIDE (Fe₂O₃) IN THE IRON ORE, AND RESULTS IN THE FORMATION OF METALLIC IRON (Fe) AND CARBON DIOXIDE (CO₂).
STATED CHEMICALLY IT IS Fe₂O₃ + 3CO = 2Fe + 3CO₂
PART OF THE SILICA (SiO₂) IN THE ORE IS REDUCED BY CARBON (C) FROM THE COKE DIRECTLY INTO SILICON (Si) WHICH PASSES INTO THE MOLTEN IRON. AT THE SAME TIME CARBON MONOXIDE GAS (CO) IS GIVEN OFF.
THE PHOSPHORUS, MANGANESE AND SULPHUR ARE SIMILARLY REDUCED FROM THEIR COMPOUNDS, AND PASS INTO THE MOLTEN IRON.
BY CONTACT WITH THE INCANDESCENT COKE THE IRON ALSO ABSORBS CARBON. THE CO₂ IN THE LIMESTONE JOINS THE FURNACE GASES, AND THE LIME (CaO) COMBINES WITH THE ALUMINA AND REMAINING SILICA IN THE ORE TO FORM THE SLAG.
THE EXIT GASES CONSIST OF NITROGEN (N), CARBON MONOXIDE (CO), CARBON DIOXIDE (CO₂), HYDROGEN (H) AND STEAM.

-IRON ORE TO PIG-IRON.

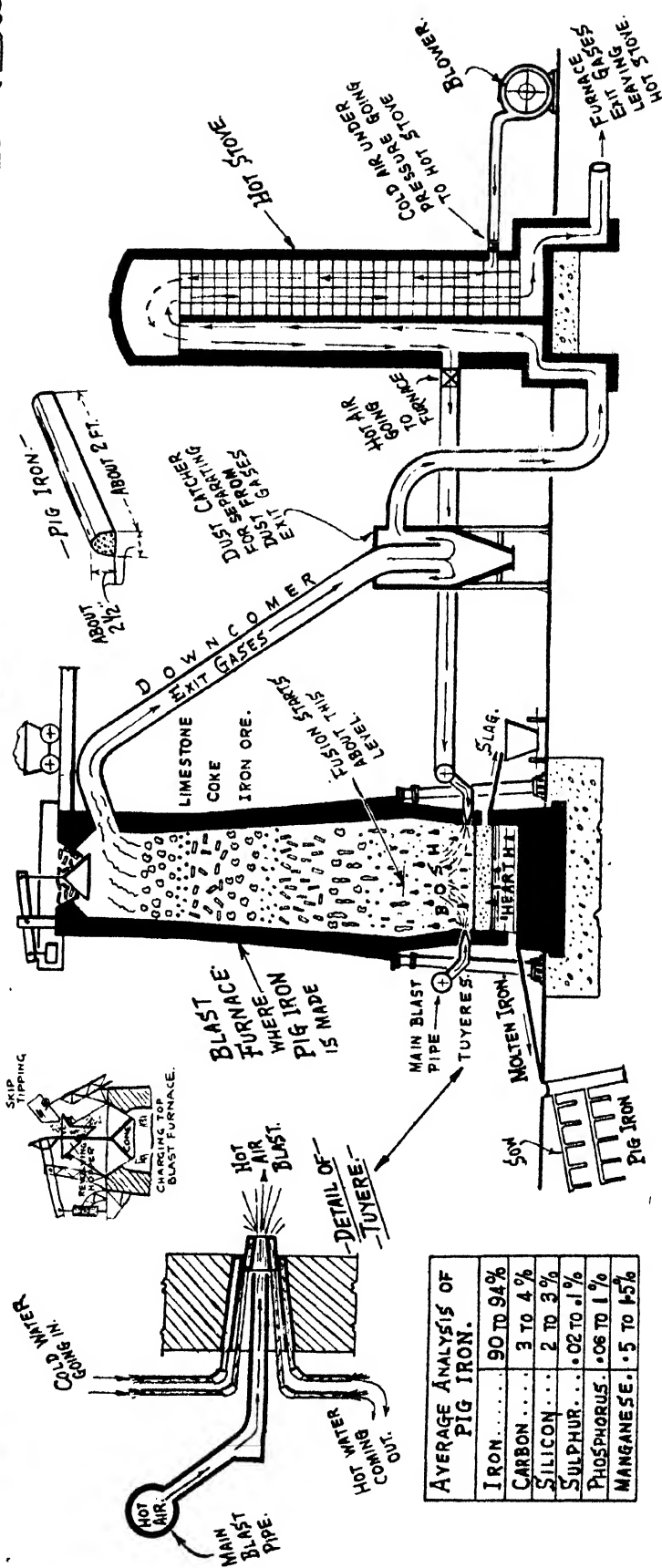

AVERAGE ANALYSIS OF PIG IRON.

IRON	90 TO 94%
CARBON	3 TO 4%
SILICON	2 TO 3%
SULPHUR	.02 TO .1%
PHOSPHORUS	.06 TO 1%
MANGANESE	.5 TO 1.5%



temperature will be not less than 500 deg. F., and it gets hotter all the way down the furnace, until the tuyere level (where the hot gases are blown in) is reached. Here the heat is around 3,000 deg. F.

IN THE FURNACE

Keep in mind that there are two main movements in the furnace ; firstly, a large volume of gases goes up and a slow movement of solids down ; secondly, there are three actions taking place, the oxygen in the hot air blast unites with the carbon in the coke to produce heat, the carbon in the hot gases causes the oxide of iron to give up this oxygen, and thus reduces it to metallic iron ; the flux unites with the silica and clay in the ore to form slag. We therefore have heat production, chemical reduction and slag formation.

In the previous chapter we drew attention to the fact that the very dense ores were calcined before they went into the blast furnace so as to drive off some of the carbonic acid gas (carbon dioxide CO_2) and also to render the mineral more porous and make it more easily melted.

Many kinds of pig-iron are made, some suitable for foundry work, others for making into wrought iron or steel. The class of mineral ore to be fed into the furnace, the amount and kind of flux to be added depend on what sort of pig-iron is required. In most cases limestone is used as the flux, and limestone contains lime and carbon dioxide. Iron ore may contain between 30 per cent and 65 per cent of iron. In addition it contains silica, phosphorous, sulphur, alumina and manganese. The duty of the blast furnace is to separate these various impurities from the iron ore and to produce one or other of the pig-irons, which all contain more than ninety per cent of iron.

HEATING THE MATERIAL

The charge of iron ore, coke and flux falls on to the hot bed of the furnace. When the coke burns away the column of material in the furnace sinks and the lower down the furnace it gets the hotter it becomes. When the heat is about 1,100 deg. F. the limestone begins to decompose and lets off carbon dioxide gas which goes into the gas stream, while the residue, which is burnt lime, moves down with the other solids. (The burnt lime itself will not melt even at the very high temperature which is reached near the bosh of the furnace, but it will unite with the silica and alumina from the mineral ore and the ash from the coke to form a molten slag.)

A change also takes place in the iron ore itself. When the hot blast air enters the furnace it comes immediately into contact with the incandescent coke. Hot carbon monoxide gas is formed ; it rises in the furnace, comes into

contact with the iron ore, and changes the iron oxide into a metallic iron and carbonic acid gas. The metallic iron comes down the furnace and the gases go up. Fusion begins near the top of the bosh, and by the time it reaches the tuyere level the whole mass is molten.

WHAT HAPPENS

What has happened to the various materials during their passage down the furnace? The limestone has been divided into lime and carbon dioxide. The coke has been burned, giving off carbon, and the resulting ash has passed down the furnace. The iron ore has been melted and, by action and interaction of the gases, become metallic iron, phosphorous, sulphur, alumina, and manganese. On its way down the furnace the metallic iron has absorbed carbon and silica. In the bosh all these materials have now become molten. The molten iron, carrying with it carbon, silicon, sulphur, phosphorus, and manganese, sinks to the bottom of the furnace hearth. Burnt lime, silica and alumina form together a molten slag and, being lighter than the molten iron, float on top of it. The molten iron is run off through a hole at the bottom of the hearth into the pig beds and the molten slag is run off through a slag hole a little higher up the furnace.

We have already seen that the charge is put in at the top. Near the bottom of the furnace there are openings for the molten pig-iron, the molten slag exit, and a series of holes in which the tuyere pipes are placed. There might be about fifteen of these pipes placed at equal spaces around the shell. Through these tuyeres the hot air, which may have a pressure of 15 lb. to a square inch, passes into the furnace.

To get some idea of what this pressure means, think of the effect of being out in a real raging gale. The force of the wind in a real gale might be as much as 15 lbs. on each square foot, and since there are 144 square inches in a square foot, it means that the pressure per square inch resulting from a real gale would be about $1/10$ th of a pound. This will give some idea of the enormous pressure behind the hot air going on to the furnace, 15 lb. a square inch is nearly 150 times as much as the pressure of a real gale of wind.

It is an interesting fact that for every ton of pig-iron produced by the blast furnace four tons of hot air are blown into the furnace from the tuyeres, and since for every ton of pig-iron produced more than two tons of material must be charged into the top of the furnace, we see that the weight of the gases going up the furnace shaft is probably double the weight of all the material coming down.

Another way to look at it is that if a blast furnace produces 800 tons of pig-

iron in the course of twenty-four hours, more than 1,600 tons of gas will have left the top of the furnace and gone down to the dust catcher. This waste gas is very hot and contains a lot of dust. When it leaves the furnace it is travelling at a high speed and carries the dust along with it. If the dust catcher has an area four times as big as the downcomer pipe it follows that the speed of the gas in the dust collector will be only one quarter as much and therefore the large particles of dust will fall to the bottom of the collector. The dust contains some iron, and after treatment, is sometimes put back into the blast furnace.

THE HOT GASES

After passing through the dust catcher the hot gases pass through stoves, where they heat up the special brickwork. They then pass along to be further cleaned. They are still very hot and the power in them is used for generating steam in waste heat boilers, coke ovens, or for the blowing engines.

Where does the hot blast air come from? Air is drawn from the atmosphere by means of special machines and compressed to 15 lbs. or more per square inch. This air then passes through the openings in the brickwork in the hot stoves. These have been made hot by the exit gases from the furnace. The air, as it leaves the hot stove, may have a temperature of 800° F. or more. This hot gas is forced along pipes until it reaches the large main pipe, which runs all round the blast furnace. From this large pipe run fifteen or more smaller pipes, which terminate in the tuyeres in the blast furnace shell.

It used to be said that in the meat-packing factories everything about the pig was used except the squeal. As we have seen, the pig-iron is used for making into castings, or into wrought iron or steel; the dust is collected from the exit gases, mixed with other materials, and put back into the furnace; the power in the exit gases is used for heating the incoming air, for driving boilers, for generating steam, and now one anticipates the obvious question, "Ah, but what becomes of the slag?" There is a lot of use for this. Among other things, slag is used for ballast on railway tracks. In certain kinds of concrete it is used as an aggregate. In Germany bricks made of granulated slag mixed with lime have been used for house building. Strange as it may appear, by blowing a jet of steam through slag, it can be changed into a material very similar in feel to cotton wool; it is grey in colour and used for insulating pipes and also for insulation in the floors of buildings.

AN ANALYSIS

We have already shown the materials which go into the making of pig-iron, and it may be of interest if we now give some rough general idea of what

these materials contain. So far as the pig-iron itself is concerned we shall deal more fully with the analysis of various kinds of pig-iron in the next chapter.

AVERAGE ANALYSIS OF :—

Pig-Iron	Iron (Fe)	93%
	Total Carbon (C)	4%
	Silicon (Si)	1%
	Manganese (Mn)	1%
	The remainder is sulphur (S) and Phosphorus (P)		
Coke	Carbon (C)	85%
	Ash	10%
	Moisture (H ₂ O)	2%
	The remainder will be sulphur (S) and other impurities.		
Limestone	Lime (CaO)	5%
	Carbon Dioxide (CO ₂)	40%
	The balance is made up of Magnesia (MgO), Alumina (Al ₂ O ₃), and Silica (SiO ₂).		
Slag	The analysis of the slag will of course depend on the mineral ore and the flux, but the following analysis gives a good idea of what slag contains.		
	Lime (CaO)	45%
	Silica (SiO ₂)	33%
	Alumina (Al ₂ O ₃)	15%
	The balance is made up of Magnesia (MgO), Ferric Oxide (FeO), Calcium Sulphate (CaS), and Manganese Oxide (MnO ₂).		

Pig-iron is re-melted in a smaller furnace, called a cupola, before being made into rainwater pipes, radiators, ornamental pillars, letter boxes, and fire-grates.

QUESTIONS ON CHAPTER II

What is the average height of a blast furnace?

What materials are charged into a blast furnace?

What comes out of a blast furnace?

What is flux and why it is used?

Sketch and describe a blast furnace.

What are hot stoves?

How much pig-iron can a blast furnace produce in 24 hours?

Is the air blown into a blast furnace hot or cold?

What is the maximum heat in a blast furnace?

What is an average analysis of :—

(1) *Pig-iron.* (2) *Coke.* (3) *Limestone.* (4) *Slag?*

CHAPTER III

CAST-IRON

From Pig-iron to Castings—Cupola.—Kinds of Pig-iron.—Graphite—Carbon—Malleable Cast-iron—Chilled Iron.

As a preliminary, we now suggest a few questions which any reader may well ask. What is pig-iron? What is cast-iron? Are there different grades of cast-iron? Is all cast-iron of the same strength; if not, why not? What are the principal properties of various kinds of cast-irons, and for what are they used? What is foundry iron? How is malleable cast-iron made? What is a chilled casting?

We showed in the last chapter how pig-iron was produced by smelting the iron ores, which are mined from the ground, in blast furnaces. As a distinction, therefore, we can say that pig-iron is the product from a blast furnace which has not been refined. It is, therefore, the crudest form of commercial iron, and the term pig-iron itself indicates no special quality or composition. According to the way the iron ores are smelted and the different ores which are used, various pig-irons are produced.

If we broke a number of pigs by means of a striking hammer and examined the fracture, we should notice that all the pigs had one thing in common; they are crystalline, just as salt or sugar are made up of little crystals. It would further be noticed different pigs show different colours, and the size of the crystals also varies. There are three main colours, and these are sometimes used as a means of classification. They are: White iron, grey iron, and mottled iron.

The different colours are caused by the different materials in the iron, for although all classes of pig-iron contain between 90 per cent and 94 per cent of iron, they also contain several other materials. These are carbon, silicon, phosphorus, manganese, and sulphur. We shall see how each of these substances affects the pig-iron. Grey irons are also sub-divided. They are generally classed as Nos. 1, 2, and 3. The White irons are also sub-divided, and the mottled irons are something between the grey and the white irons. As a rule, for commercial purposes pig-irons are divided, therefore, into seven or eight varieties.

SOFTER IRONS

Nos. 1, 2, and 3 are the greyer and the softer irons, and these are generally used for the making of foundry cast-iron. These are the goods which are cast in moulds, and which builders use as cast-iron pipes, radiators, manhole covers, fire-grates, and the like. For heavy machine castings more of the No. 3 than No. 1 would be required, and the proportions of how much No. 1 pig, No. 2 pig, and No. 3 pig are required is a matter, of course, for the expert foundryman to decide.

The harder and whiter irons are used for making into wrought iron and these are generally known as Nos. 5, 6, 7, and 8. No. 4 is sometimes mixed with No. 3 to form a foundry iron. Nos. 5 and 6 are generally known as forge. They are between grey irons and the white irons, and of mottled appearance.

Although the product from the blast furnace is a crude kind of cast-iron, it is always known as pig-iron.

The pig-iron for making into iron castings is melted in a smaller-sized cylindrical furnace, which has an outside shell of steel plates and is lined with firebrick. *Plate 3* shows one type of this furnace, which is known as a cupola. The materials which are charged into the cupola are alternate layers of pig-iron and scrap iron, fuel which is generally coke, and as much limestone as is required to form a flux for the ash.

OYSTER SHELLS

There seems to be little connection between oyster shells and cast-iron, but if the reader should on some occasion be passing a cupola and see about half-a-ton of oyster shells near the base, he will probably be quite wrong in assuming that the management have had a grand feed, and that these oyster shells are being burnt in the cupola to hide up the traces. Oyster shells contain calcium carbonate, which makes a very good flux. The air blown into the blast furnace is preheated, but the blast used in the cupola is cold.

When the pig-iron and scrap are melted, the molten iron is run off near the bottom of the cupola. During the melting time some of the manganese in the pig-iron has been oxidised off, and although the total amount of carbon will not have been much altered, the nature of the carbon has been changed. Carbon exists in iron in two forms. It can be either combined with the iron or it can be separate from the iron in the form of graphite. We know that carbon exists in many forms. Eight parts out of ten of coal and coke are probably carbon. A diamond is a form of carbon, and graphite is another form. Most of the blacklead used for polishing fire-grates is graphite. The lead in a pencil is not lead, but is also a graphite.

The effect of carbon upon iron is very important. Whether that carbon exists as a combined carbon or only as a graphite carbon makes a great difference to the nature of the cast-iron. We, therefore, see that although most pig-irons contain between 3 per cent and 4 per cent of carbon, we cannot tell to

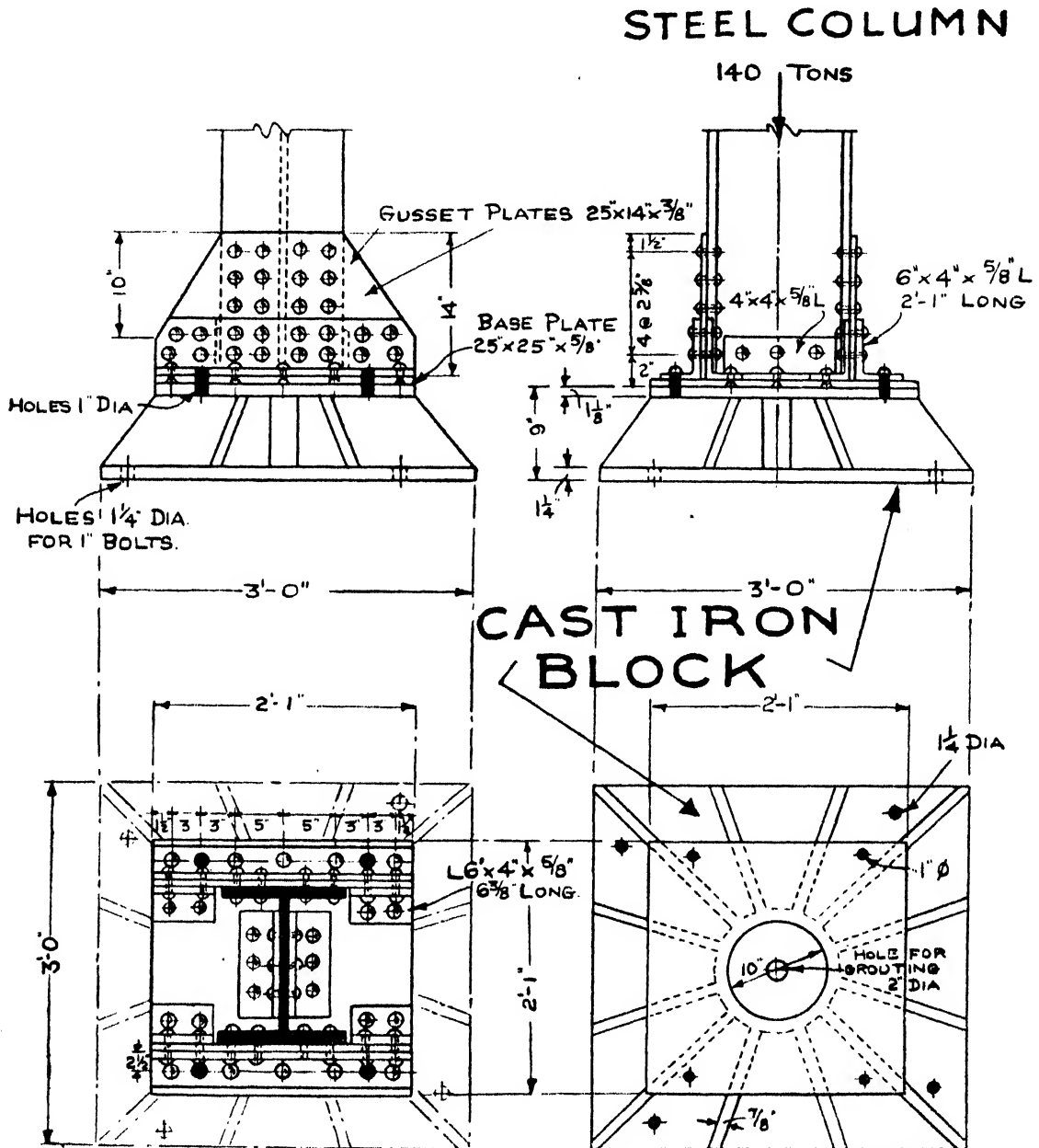

what grade the pig-iron belongs unless we know whether the carbon exists in the combined form or as a graphite. A pig-iron, which when broken has small white crystals will contain most of its carbon in a combined form. This makes the iron hard, strong, brittle, and easy to melt. If, on the other hand, the broken pig-iron has large grains, and the fracture looks grey, it is probably because

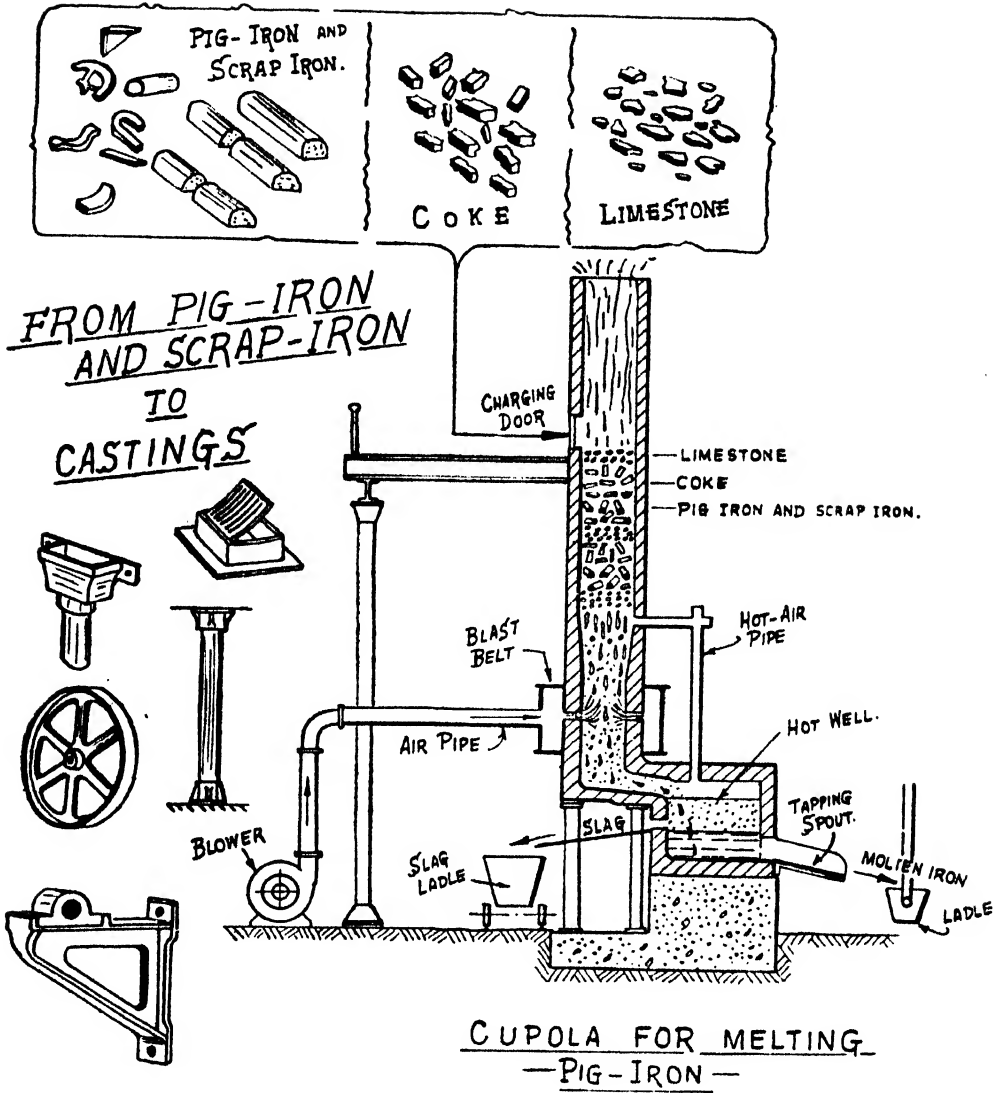

most of the carbon is in the form of a graphite. This iron will be softer than the white iron.

We already know that the pig-irons graded as Nos. 1, 2, and 3 are grey and soft irons. This is because the carbon is a separate graphite. We also know that pig-irons Nos. 5, 6, and 7 are white irons. In these the carbon exists in a combined form, and is really part of the iron.

After the pig-iron has been melted in the cupola and run into special moulds in the foundry, the resulting shapes are called iron castings, and these are the articles generally called cast-iron, or castings.

CAST-IRON COLUMNS

Cast-Iron Columns are frequently met with in alteration work and the following Table gives a few examples of Safe Loads in Hollow Cast-Iron Columns in accordance with clause 52 L.C.C., 1932 Code, and L. B. Act 1930, Third Schedule, Section 20.

SAFE LOADS FOR CAST IRON COLUMNS OF HOLLOW CIRCULAR CROSS SECTION					
OUTSIDE DIAMETER	THICKNESS OF METAL	HEIGHT IN FEET WITH BOTH ENDS FIXED :-----			WEIGHT PER FOOT :-
		8	10	12	
INCHES	INCHES	TONS	TONS	TONS	LBS.
12	2"	262.3	241.8	219.9	196
	1½"	209.7	191.9	176.8	155
	1"	147.9	136.6	126.2	108
10	1½"	156.9	140.9	125.7	125
	1¼"	135.9	121.0	110.0	118
	1"	113.2	101.8	91.9	89
8	1¼"	92.7	79.5	66.2	83
	1"	78.9	68.2	57.2	69
	¾"	61.9	54.2	46.5	54
6	1"	44.7	34.5	23.5	49
	¾"	36.7	28.7	20.4	39
	½"	26.3	21.1	15.5	27

USE OF SCRAP IRON

Cast-iron has a very valuable property of getting stronger and more dense by being remelted. For this reason, and also because it is cheap, scrap iron is often mixed with the pig-iron. Scrap iron is cast-iron which has been broken up. Old gear wheels, machine frames, broken pillars, faulty castings produced in the foundry, all these are used as scrap iron. Sometimes as much as a third of the total iron charged into the cupola is scrap iron.

The flux is used in this case to carry off into the slag anything in the iron which is not metal, to help to remove any sulphur which may exist either in the iron or in the fuel, and also to carry off the ash content in the fuel. The flux is generally in the form of limestone.

The fuel is generally coke, and its prime object is to produce the necessary heat for melting the iron and the flux.

Materials are put into the cupola through a charge door near the top. Air is blown into the cupola through the openings or tuyeres located near the bottom. Whereas the blast furnace runs continuously day in and day out for months, a cupola does not run continuously. It is a daily operation. Molten iron is tapped off usually late in the afternoon. Moulds which have been made in the foundry are filled from a ladle which receives molten metal from a spout near the base of the cupola.

Silicon makes molten iron run more freely, but it causes precipitation of graphite. It is helpful to some extent because it prevents the formation of blow holes in the castings. On the other hand, it also tends to make a casting weaker.

AMOUNT OF SULPHUR

Sulphur makes cast-iron weaker. Castings made from pig-iron which is high in sulphur are likely to have flaws in the form of blow holes or cracks. The amount of sulphur should, therefore, generally not exceed one quarter of 1 per cent.

Phosphorus makes cast-iron remain fluid, and run freely. For this reason it is possible to get very intricate and complicated castings by using a pig-iron which is high in phosphorus, but, on the other hand, it makes the cast-iron weak. Generally more than half of 1 per cent of phosphorus is not considered desirable.

An analysis of the softest grade of iron, such as No. 1 would be approximately : Iron 92 per cent ; graphite carbon, 3.5 per cent ; combined carbon, 0.2 per cent ; silicon 3 per cent. (This is the softest of the grey foundry irons.)

The hard white irons Nos. 0 and 7 would have an analysis : Iron, 94

per cent ; graphite carbon, 0.5 per cent ; combined carbon, 3 per cent ; silicon, 0.5 per cent.

Malleable cast-iron is made by annealing iron castings. We have already seen that to produce a white iron, the carbon must be in a combined form, and the annealing process consists of converting this hard white iron into a ductile, tough, and malleable iron. This is done by changing the combined carbon into free carbon. The castings are cleaned and packed into boxes containing crushed hematite ore, iron scale, or a slag which is very rich in iron oxide. The boxes are then placed in a special annealing oven, which has a temperature of about 700 to 750 degrees centigrade, and are kept there for three or four days, depending on whether the castings are small or large. Cooling should be as slow as possible, and generally a day or more is allowed for cooling down the oven.

As a result of this process an iron casting which before being made malleable was brittle and hard is made tough and malleable. Most of the iron chains used on bucket elevators are made of malleable iron ; a great many pipe fittings, elbows, bends, and window fittings are also made of it.

Sometimes a hard surface and a soft interior is required. The process really means the changing of a grey iron casting into one which has a grey interior and a white or hard skin. This is done by introducing chills into the mould. These chills are made of iron, and when the molten iron from the cupola is poured into the mould, the part which comes into contact with the iron chill cools very rapidly, while the interior of the casting cools more slowly.

In the slow cooling iron the carbon tends to separate and take the form of graphite. In the fast cooling casting the carbon remains as a fixed or combined carbon. This produces a white and hard iron. What it really amounts to is that the surface or rim of the wheel which is cooled rapidly is very hard and does not wear away, while the inside part of the wheel is relatively soft, and, therefore not very brittle, and does not break very easily.

QUESTIONS ON CHAPTER III

Is cast iron all the same strength ?

What is a chilled casting ?

How is malleable cast iron made ?

What is pig iron ?

What is an iron casting ?

What is the effect of sulphur and phosphorous on cast iron ?

What is combined carbon ?

Sketch and describe a cupola.

WROUGHT IRON PRODUCTION

Wrought Iron—Puddling Furnace—Balls and Blooms—Use of Wrought Iron.—Effect of Heat—Strength.

WROUGHT IRON PUDDLING FURNACE

IN these days mild steel has largely displaced wrought iron. Wrought iron which really means worked iron is made from pig-iron in a puddling furnace. In Chapter III we showed that pig-iron was divided into about eight different grades, and that Nos. 1, 2, 3 and sometimes 4 were used for making into iron castings, and are therefore known as foundry irons. The whiter and harder irons are used for making into wrought iron and steel. The pig-iron best suitable for making into wrought iron is known as forge iron. It should contain less than $\frac{1}{2}$ per cent of silicon, less than 1 per cent of phosphorus, and less than $\frac{1}{10}$ th of 1 per cent of sulphur. Pig-iron will have between 3 and 4 per cent of carbon and between 92 and 94 per cent of iron. Pig-iron used is a brittle material; it cannot be bent either cold or hot. Wrought iron, on the other hand, is particularly ductile, can be hammered into various shapes and bent either hot or cold.

THE PUDDLING FURNACE

What takes place in the puddling furnace to cause the pig-iron, which is a brittle material, to become ductile? A very good grade of wrought iron might contain as much as $99\frac{1}{2}$ parts of iron out of every 100, so that all the impurities put together, including carbon, silicon, phosphorus and slag will be less than half a part in 100. In the reverberatory furnace, therefore, we can say that the non-metallic substances have been driven off. There are various grades of wrought iron. The ordinary grade has about 97 per cent of pure iron, and as we have just said, a very good grade has $99\frac{1}{2}$ per cent of pure iron. How has this change from pig-iron to wrought iron been brought about?

A view of a typical puddling furnace is shown, (*Plate 4*). A puddling furnace is a reverberatory furnace, that is to say, the flame from the fire is "reverbered" or "beaten back" on to the metal which rests on the hearth of the furnace. The sides and bottom of the furnace are lined with some material

- A... FIREGRATE.
- B... FIRING DOOR FOR FUEL.
- C... WORKING DOOR.
- D... WORKING BED OR HEARTH.
- E... DAMPER
- F... REVERBERATORY ROOF.

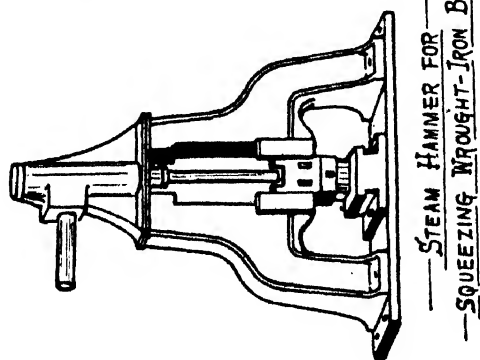
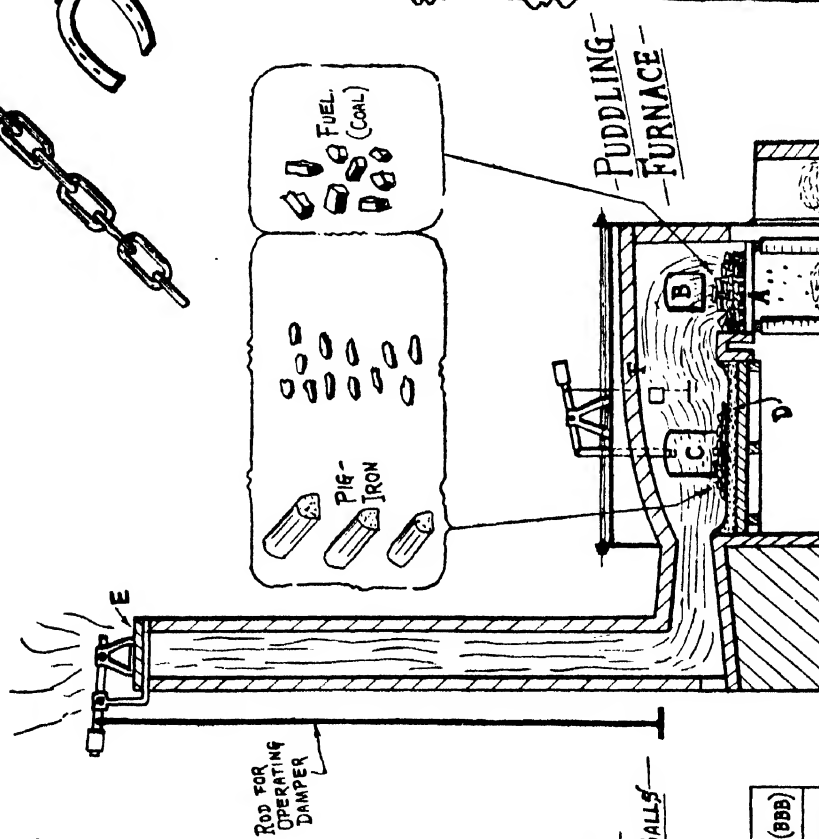
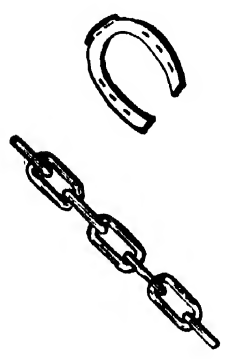
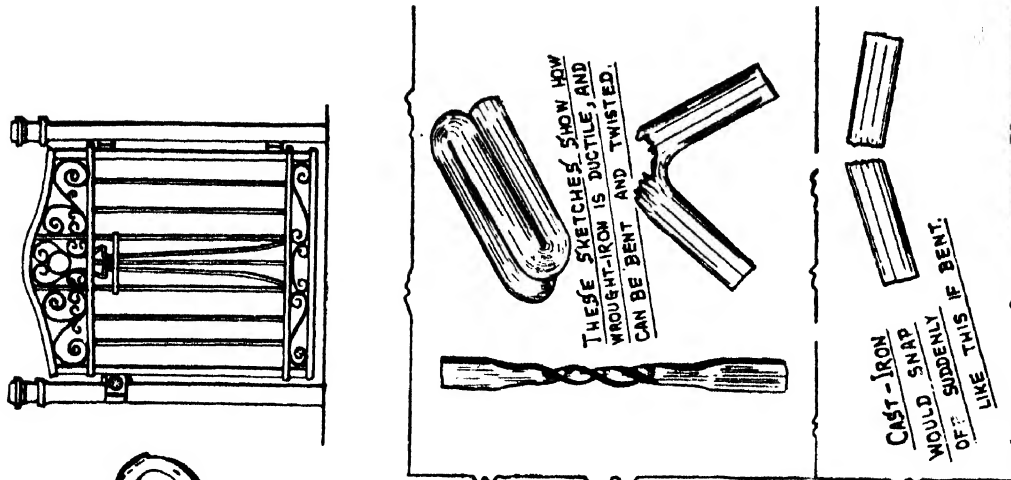

FIG - IRON TO WROUGHT - IRON

ANALYSIS OF GOOD WROUGHT IRON (BBB)

IRON	CARBON	SILICON	SULPHUR	PHOSPHORUS	MANGANESE
99.5%	.07%	.1%	.01%	.08%	.04%

THIS IS VERY NEARLY PURE IRON.

rich in iron oxide. This material may be a high grade hematite ore, the roasted tap cinder or slag from the puddling furnace, or the iron scale which is collected from round the steam hammers.

The pig-iron is charged by hand, and flames from the coal fire beat upon it. The iron melts and is stirred or puddled with long rakes which are pushed through the working door. The carbon in the pig-iron is converted into gases, and this carbon monoxide gas causes the metal to bubble and boil, during which time the puddler stirs or agitates the iron vigorously.

During this boiling period the slag is tapped off. When this is cool it is known as tap cinder. As the carbon and other impurities in the pig-iron are removed by oxidation the material begins to form into a pasty mass, and this is collected by the puddler into balls or blooms of soft spongy iron. These are pulled from the puddling furnace on to a steel-plate floor and dragged either to a steam hammer or squeezing machine, where the slag which is much more fluid than the pasty iron, is squeezed out of the metal.

The iron is now a crude form of wrought iron. It is further improved by re-heating and re-hammering, cutting up, and heating and re-rolling several times. Each time this process is done the strength and quality of the iron is improved and the grade of iron is indicated by the marks B, BB, and BBB. The B, which is the lowest commercial form of wrought iron, is suitable for general smithing purposes, while the double B and treble B are used for chains, some boiler plates, and very important work where a uniform quality is essential. Wrought iron is rolled and forged into shape; it is never melted and cast into a mould like cast-iron or cast-steel.

We have already mentioned that wrought iron resists corrosion or rusting better than ordinary mild steel, and for this reason wrought iron is often used for links and chains and belts, particularly where these are located between tide levels. Iron which is alternatively wet and dry, that is, sometimes under the sea at high tide and in the air at low tide, will corrode more quickly than where the iron is always under water or always in the air.

Although stainless steel is capable of resisting corrosion of sea water and will not corrode if exposed in air, it is more brittle than wrought iron. It does not stretch as much before breaking, and for this reason first class quality treble B Lowmoor iron is still largely used for chains and bolts on piers and wharves.

The man in the blacksmith shop, or in the builder's yard, may have a piece of iron and not know whether it is cast-iron, wrought iron, or mild steel. A good general way of distinguishing them is to nick one side of the bar with a set or chisel, and then bend the bar over with the cut on the outside of the bend. If the material is wrought iron it will show distinctly fibrous something like the

fibres on the branch of a tree. If it is ordinary wrought iron the presence of black-looking slag lines will be seen. In the best quality wrought iron these slag lines will not be seen, because the slag will have been eliminated during the process of making the wrought iron, but the fibrous fracture will be very noticeable. If it is mild steel, the bar will show very little fibre, but will snap fairly smartly across.

EFFECT OF HEAT TEST

To the inexperienced eye it is not very easy to distinguish from the fracture whether the material is mild steel or cast-iron; a heat test will immediately show the difference.

If a mild steel bar is heated to a red heat, the bar will bend without breaking but if it is cast-iron it will snap off. Cast-iron, when heated to a red heat, is said to become rotten. Although a malleable cast-iron is very ductile when cold, in fact, it can be twisted all over the shop without breaking, it loses its ductility when heated to a red heat.

These sort of tests are not difficult to make, and they are often used to distinguish between the various materials.

Two bars of wrought iron can easily be welded together if they are previously heated to a good white heat. If a full red, wrought iron becomes pasty and plastic, and will stand any amount of hammering and reduction in size, either under a steam hammer or a blacksmith's anvil.

It can be bent and rolled. Although it welds better than mild steel it is not so strong, and for this reason mild steel has very largely displaced wrought iron.

Cast-iron, if it is made hot and hammered, snaps very quickly. If it is desired to make a hole through a wrought iron bar, this can be done by heating in a fire and punching out a hole on the anvil, or alternatively a hole can be punched when the metal is cold by a punching machine. Wrought iron can also be "swaged down" or "knocked up" after heating by a blacksmith, but none of these operations is possible in the case of cast-iron; they would all cause the iron to break.

BREAKING POINT

If a bar of wrought iron one inch square with an eye forged at each end is supported at the top end and hung vertically, it would probably take a steadily applied load of about twenty tons to break it if the wrought iron was an average commercial quality. It might be as much as twenty-six or twenty-eight tons for best quality refined wrought iron.

The suspension bar is one inch square, and is therefore one square inch in

area. The load is pulling it apart, that is, causing it to fail in tension. We, therefore, say that wrought iron has a breaking strength in tension of between twenty and twenty-eight tons per square inch, depending on the quality of the wrought iron. It is interesting to notice that wrought iron stretches about $1/10,000$ th part of its length for each ton per square inch of section.

Generally, before the bar breaks it will stretch $1/5$ th of its length, so that the marked distance of ten inches would be increased to twelve inches before the bar broke. It is easy to see this stretch by eye, and therefore, a good deal of warning is given before the bar breaks.

QUESTIONS ON CHAPTER IV

What is wrought iron?

Sketch and describe a puddling furnace.

Can wrought iron be bent or twisted?

How pure can wrought iron be made?

How long has man used iron?

CHAPTER V

BESSEMER STEEL MAKING

*Pig-iron to Bessemer Steel—Early days—Converter—Effect of Impurities—
Linings for Converters—Spiegeleisen—Ingots—Soaking pits.*

FROM MOLTEN PIG-IRON TO BESSEMER STEEL

EGYPTIANS and Assyrians made and used iron more than 3,000 years ago. Since they had carbon in the form of charcoal, it is probable that they made some form of steel, either intentionally or unintentionally. For steel is really a mixture of pure iron or nearly pure iron and carbon. We know that in a puddling furnace the impurities can be removed only after repeated heatings and hammerings, and that we can get a wrought iron which is 99½ per cent pure iron. In other words, out of every 100 tons of this special wrought iron, more than 99½ tons are pure iron, and all the impurities put together weigh less than half a ton.

EARLY DAYS

About 300 years ago steel began to be made in this country by heating bars of relatively pure iron with charcoal. Layers of iron and charcoal were placed one on top of the other, and lighted. When the heat reached about 600 degrees centigrade, the carbon from the charcoal became absorbed in the iron, and the longer the heating was carried on, the deeper the carbon sank into the iron. This process is known as the cementation process.

Although steel was produced, it was not a reliable product. In 1740, a Doncaster watchmaker named Benjamin Huntsman, requiring a reliable steel for making into clock and watch springs started to make experiments to that end. After trials and failures, he at length succeeded in making a cheap and reliable steel which was superior to the steel made by the cementation process. Huntsman's process was to cut up the iron into small pieces and melt them in a crucible. The heat was supplied by a coke fire, which surrounded the melting pot. Huntsman had found the method of making steel by the crucible process. To this day some of the best tool steels are made by a process very similar to that which Huntsman discovered.

The crucibles are made from a mixture of clay and graphite. It will be remembered that in the chapter on pig-iron we pointed out that graphite was

a flaky form of carbon. Graphite alone is not strong enough, and clay alone would shrink and crack.

In 1856 Henry Bessemer discovered that by blowing a current of air through molten iron (without adding any additional fuel), a lot of the impurities contained in pig-iron were removed. This discovery proved to be one of the most important inventions of the century. Bessemer had found a means of making purer iron without the necessity of using either coal or charcoal. Although manganese, silicon, carbon and some of the earthy impurities had been removed from the iron, sulphur and phosphorus had not been removed. For this reason there were many disappointments at first, for sulphur in iron makes it red short. Phosphorus, too, although it makes the iron melt easier, and remain fluid longer, causes brittleness and weakness.

To the engineer, as to other men, difficulties are there to be overcome, and it was found that by adding spiegeleisen (mirror iron) to the molten iron after it had been "blown" in the converter a good commercial steel could be produced. Spiegeleisen contains carbon and manganese, and by adding this to the molten purified iron, a good steel is produced, for the manganese, which is very hard and tough, corrects the red shortness (brittleness when hot due to sulphur), and the carbon produces the necessary hardness.

From this time steel was made on a commercial basis. In these days, steel has very largely displaced cast-iron for railway bridges and beams, and mild steel is now very rapidly replacing wrought iron. If a refined iron which has been melted, and to which a definite amount of carbon has been added, contains less than half of 1 per cent of carbon, it is known as mild steel. If the carbon content is between $\frac{7}{10}$ ths of 1 per cent and 1 per cent, the steel is medium hard steel. If the steel contains more than 1 per cent and less than $1\frac{1}{2}$ per cent of carbon, it is known as a hard steel.

THE CONVERTER

The vessel in which the molten iron is poured and through which the air is blown is pear-shaped and known as a converter. *Plate 5* shows a mixer, a ladle, and the Bessemer converter in various positions. Molten pig-iron from the blast furnace is run into either channels in the sand for the making of pig-iron, or it can be run into a large cylindrical drum, which may hold anything from 150 to 400 tons of molten metal, called a mixer. The mixer revolves on runners, and the molten metal can be tipped out into ladles. The ladle is carried along to the front of the converter. This vessel is turned down to near the horizontal position as shown in the drawing, and the molten iron from the ladle is run into it. Before the converter is turned back to the vertical position the air blast is turned on. The air blowing through

the molten metal causes an increase of temperature. As the silicon, manganese, carbon, sulphur, and phosphorus begin to burn off, a blazing shaft of burning gases shoots out of the mouth of the converter. As the various impurities are burned off the flame shortens, and the sparks become much less dazzling. Although scientific instruments are provided, the skilled worker can tell by the appearance of the flame belching out of the mouth of the converter at which stage the process has arrived.

When the first converter was made the lining was of silica. We have already noticed that the amount of phosphorus and sulphur in the molten pig-iron was not reduced, and that the addition of spiegeleisen was necessary to produce a good steel. In addition to Bessemer, other men were working on this problem, of how to get the sulphur and phosphorus out of the iron while it was yet in the converter. They found that if, instead of using a silica brick or silica rammed lining in the converter, they used a basic lining—that is, a material such as magnesite ore or burnt dolomite mixed with hot tar—it was possible to remove both sulphur and the phosphorus as well as other impurities. When the molten metal is charged into the converter, lime is added, and by this means a basic slag (the opposite of an acid slag) is produced. The excess of lime absorbs the phosphorus into the slag.

THREE SEPARATE PARTS

The converter consists of an outside shell of heavy steel plates and a lining of refractory material. The converter is made in three separate parts, so as to permit the lining to be renewed—the base, the body, and the throat. Heavy hollow steel journals mounted in bearings support the converter, and to these journals are fixed toothed wheels which are turned by a high-power motor.

The method of making steel in the Bessemer converter revolutionised the industrial world, but it was not many years before another method of making steel, known as the open-hearth process, was invented, and at the present time for every ton of steel made in Great Britain by the Bessemer process twenty tons are made by Siemens-Martin open-hearth furnace.

Pig-iron suitable for making into steel by the acid Bessemer process should be low in sulphur and phosphorus and fairly high in silicon. An analysis of a pig-iron suitable for Bessemer acid process is as follows :

Silicon	1.5 to 2.5 per cent
Manganese	0.4 to 1.0 per cent
Carbon	3.5 to 4.0 per cent
Phosphorus	0.04 to 0.1 per cent
Sulphur	0.02 to 0.07 per cent

The balance is iron.

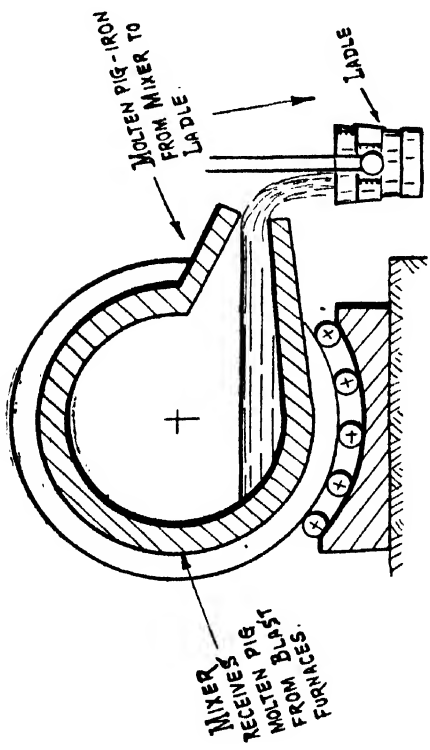

IN THE FIRST BESSEMER CONVERTERS THE LINING WAS SILICA. WITH SILICA LINING THE PHOSPHORUS AND SULPHUR IN THE MOLTEN PIG-IRON ARE NOT REMOVED. IN THE ACID BESSEMER PROCESS, THEREFORE, ONLY PIG-IRON WITH VERY LOW PHOSPHORUS AND SULPHUR CAN BE TREATED. IT MUST ALSO BE FAIRLY HIGH IN SILICON. THE STEEL PRODUCED IS CALLED ACID BESSEMER STEEL.

LATER EXPERIMENTS PROVED THAT IF THE LINING WAS MAGNESITE OR BURNT DOLOMITE, THE PHOSPHORUS AND MOST OF THE SULPHUR WOULD BE REMOVED AND ABSORBED IN THE SLAG. THIS LINING IS A BASIC LINING, AND ALLOWS PIG-IRON CONTAINING MORE SULPHUR, MORE PHOSPHORUS AND LESS SILICON TO BE USED. THE STEEL PRODUCED WITH THIS LINING IS CALLED BASIC BESSEMER STEEL. THE FLUX USED IS LIME

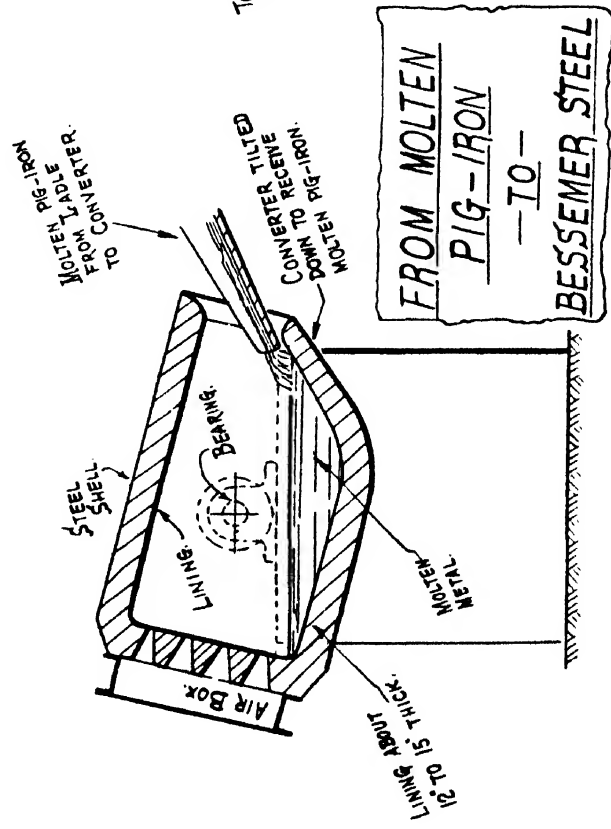
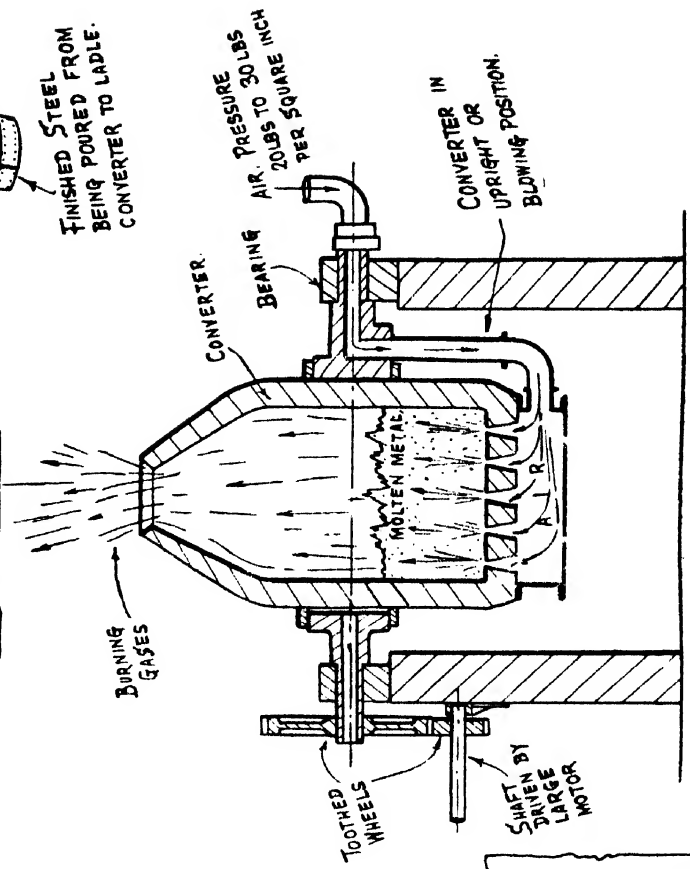
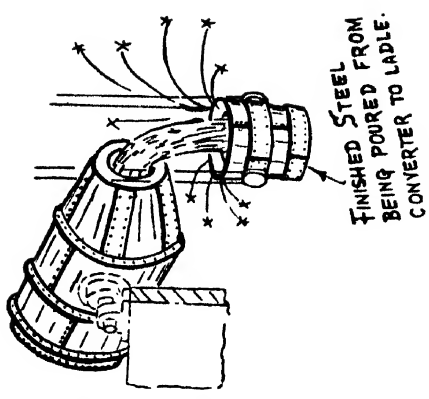

It will be noticed that the amount of silicon is rather high ; this is in order to ensure that a sufficient quantity of slag of a satisfactory character is made, and also to provide heat. (Silicon has a high calorific or heating power.) The slag from the acid converter will probably contain more than 60 per cent of silica, and the lining of the converter gradually becomes fluxed away.

In the basic process, where the lining is magnesite or dolomite, not only the carbon, silicon, and manganese, but the phosphorus and sulphur are also removed. For this reason, pig-iron to be used for making into Bessemer steel can have a fairly high phosphorus content, but the silicon should be kept low, otherwise there is a danger of producing an acid slag, especially as lime is added as a flux. The pig-iron used for making into basic Bessemer steel is generally within the following limits :

Silicon	0.2 to 1.0 per cent
Manganese	0.3 to 2.0 per cent
Carbon	2.75 to 3.5 per cent
Phosphorus	1.0 to 3.0 per cent
Sulphur	0.02 to 0.3 per cent

The balance is iron.

In the basic process the slag is first eliminated. Then the carbon is oxidised. The amount of phosphorus remains the same until the carbon has been completely eliminated. The phosphorus then becomes oxidised, and is taken into the slag together with some of the sulphur.

After the blow or process is finished and the molten steel in the Bessemer converter has reached its standard of purity, the converter is revolved on its trunnions and the molten steel poured into a special ladle which is lined with refractory bricks. The ladle is suspended from an overhead crane, which carries the ladle to the ingot moulds. These ingots might be twelve inches or fourteen inches square and five feet high. They are generally made a little bigger at the base than at the top, so that the mould can be more easily pulled off, or stripped, from the ingot. This stripping is done as soon as the ingots are solid and while they are still very hot. The ingots are then taken to special soaking pits. These are deep chambers let into the ground which are kept hot, either by coal or gas.

TEMPERATURE OF INGOTS

The object of putting the ingots into the soaking pits is to equalise the temperature of the ingot. The walls of the soaking pits get very hot and reflect the heat. By doing this the heat from the middle of the ingot is allowed to soak out slowly to the outside face. If this was not done, steel would not

satisfactorily forge or roll. The solid ingots from the soaking pits are rolled into smaller-sized shapes, called billets, blooms, and slabs, and from these billets and blooms tramlines, railway lines, rolled steel beams, and the round bars for reinforcing concrete are made, by passing the hot material through a succession of steel rollers.

The slabs are rolled into mild steel plates for making into tanks and steamship plates. They are later re-rolled into thinner plates called sheet steel, from which corrugated iron sheets are made.

From this mild steel drop forgings or stamping are made. The dies are made of special steel, and a great many articles, such as coupling-links between railway trucks, spikes for rail tracks, and spanners are made by drop forgings. We showed in a previous chapter how castings are made in iron.

In these days many castings are made in steel because they are much more tough and not liable to snap. Many-toothed wheels, heavy machine frames, and locomotive parts are made as steel castings.

QUESTIONS ON CHAPTER V

What did Bessemer discover about blowing a current of air through molten iron?

What is a converter?

How does the lining effect the steel produced?

What is an ingot?

CHAPTER VI

OPEN HEARTH STEEL

Open Hearth Steel—Siemens-Martin—Gases—Hearth-Lining—Silica—Dolomite—Stainless Steel—Chromium—Nickel—Classification of Carbon Steels.

THE production of steel by the Bessemer converter process had a tremendous effect on the industrial life of this country. Not many years after its introduction another process was perfected which was destined to be even more used than its predecessor. It was the open hearth process, and is usually known as the Siemens-Martin process, because it was the result of the work of Siemens in England and Martin in France.

Siemens was the first to use the regenerative system of heating by gas. Martin did a lot of experimenting on the metallurgical side of the operation. He found out that soft iron and steel scrap could be mixed in with the charge of pig-iron. The furnace is quite different from the Bessemer converter. In the open hearth furnace the hearth is supported on heavy girders, the hearth is of special firebrick and the pig-iron and scrap are melted in the hearth by means of a mixture of preheated producer gas and air.

PREHEATING PROCESS

This preheating is done by utilising the heat carried away from the furnace by the burnt gases. These gases, on their way to the chimney, are sent through regenerative chambers filled with chequer brickwork. They heat up the brickwork in the chambers in the same way as the gases from the blast furnace heat up the brickwork in the hot stoves.

In *Plate 6* the regenerators are shown and the arrows show the gases and air going from the right-hand side of the furnace, passing over the molten metal in the hearth, and leaving the furnace on the left-hand side. At this stage the chequer brickwork in the regenerator on the right side of the hearth has already been heated, and therefore the incoming gas and air are preheated before they reach the furnace hearth.

The gases leaving the furnace hearth pass through the two chambers to the left and away to the chimney. After they have been passing through the

brickwork for twenty minutes or half an hour the bricks are, of course, at a tremendous heat. The valves are then operated so that the gas from the producer and the air which is necessary to mix with it to cause combustion, come into the furnace on the left-hand side through the chambers where the brickwork has been made really hot.

The burnt gases then go out at the right-hand side to warm up the bricks, which by this time have given up a good deal of their heat to the gas and air. The air going into the furnace is heavier than the producer gas, and to ensure complete mixing the air port is put in higher up than the gas port.

In the drawing five doors are shown, and it is through these doors that the pig-iron, scrap and molten metal are charged to the furnace hearth. The molten metal is charged through a ladle, and the other materials are often charged by a special charging machine. The charging door side is generally called the front of the furnace.

Just as in the Bessemer process acid and basic steel are produced, so also in the open hearth process acid and basic steel are produced. The general construction of the furnace is the same, but the lining has a silica base for the acid steel and a basic base such as burnt dolomite or magnesite for basic steel. The main difference between the two processes is that in the acid process the phosphorus in the charge is not reduced, while in the basic process the phosphorus is reduced. In both processes the carbon, manganese and silicon are removed. The carbon oxidises to carbon dioxide and escapes with the gases. In the basic process lime is added as a flux. The oxygen in the iron ore combines with the phosphorus, manganese and silicon to form oxides which unite with the limestone and form the slag.

Probably eight out of every ten tons of steel produced in Great Britain are produced by the basic open-hearth process. In the furnace itself the carbon is generally reduced below the amount which will be required in the final steel. It is therefore necessary to add some carbon to bring the final product to the required amount. In the case of basic steel this can be done by adding crushed coal, charcoal, or coke, or a pig-iron called ferro-manganese, which is rich in both manganese and carbon. These are generally added to the molten steel as it flows into the ladle.

At the back of the furnace there are holes through which the slag and molten steel are run off into the ladles. The slag from basic steel contains quite a large amount of phosphorus, and is useful when finely ground as a fertiliser. The slag from acid open-hearth furnaces does not contain phosphorus, and it is of no use as a fertiliser.

The molten metal from the furnace is run off into ladles, from which it is poured either into ingots or into moulds made in the sand. These, of course,

BASIC STEEL OR ACID STEEL?

WHEN THE FURNACE IS LINED WITH SILICA BRICKS, SILICA SAND OR STICEOUS ROCK NAMED GANISTER (FROM WHICH SILICA BRICKS ARE MADE), THE STEEL PRODUCED IS KNOWN AS ACID STEEL.

WHEN THE FURNACE IS LINED WITH MAGNESITE BRICKS OR BURNT DOLOMITE (WHICH IS A LIMESTONE CONTAINING MAGNESIA), THE STEEL PRODUCED IS KNOWN AS BASIC STEEL.

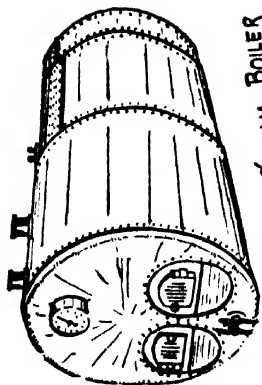

STEAM BOILER MADE OF MILD STEEL PLATES.

WATER-TANK MADE WITH PRESSED STEEL PLATES AND SUPPORTED ON FRAMED STRUCTURE MADE OF ROLLED STEEL SECTIONS.

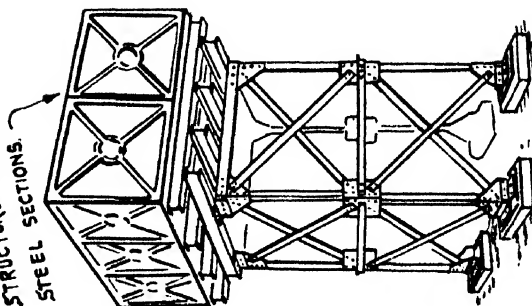

HEARTH LINING.

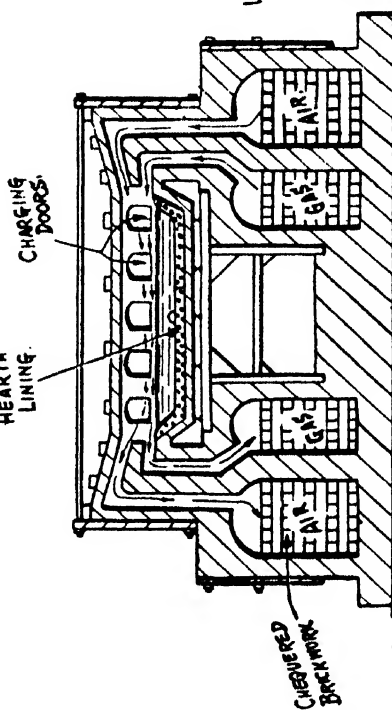

MOLTEN STEEL

TAPPING HOLE

LADLE

INGOT

CHARGING DOORS.

CHARGING FLOOR.

SIDE VIEW OF TAPPED FURNACE, SHOWING MOLTEN STEEL BEING TAPPED OFF INTO LADLE, AND THEN INTO INGOT MOULDS.

—SIEMENS - MARTIN OPEN - HEARTH FURNACE.—

when cold are steel castings. All kinds of railway wagon wheels, spanners, parts for machines, gear wheels, pump casings, turbine casings, liners for ball mills, hammers, picks, knives, scissors, saws, chisels and razors are made from steel.

MANY KINDS

To enumerate the different kinds of steel is a task about as easy as counting the pebbles on the seashore. Although the articles we have just enumerated, and many thousands of others, are made of steel, it is not to be assumed that they are of the same kind of steel ; in other words, the ladle carrying the molten metal from one furnace charge does not contain a steel which is suitable for every purpose. The steel, for instance, which is suitable for rolling into steam beams for buildings and bridges would be unsuitable for making into a crank shaft for a motor-car.

Just as pig-iron is divided into various classes, so steel is divided into various classes. There are straight carbon steels, and there are alloy steels in which other materials such as tungsten, manganese, chromium and vanadium are added. Sometimes two or more elements may be added to the steel.

STAINLESS STEEL

Mr. Brierley in 1912 was making experiments and testing various steels to try and find a material which would be suitable for lining guns, so that when the shell was fired the corrosive gases which force the shell on its way would not damage the bore of the gun. Many specimens and test pieces of steels containing varying amounts of chromium and other alloys were tested, and the results noted. One of the men around the plant where the experiments were being made noticed that one of the test pieces was still bright and shiny, although it had been exposed to the air for days. It had been found that a steel containing between 10 and 14 per cent of chromium would resist rust.

It is difficult to realize in these days, when there are a thousand and one uses for stainless steel, that this discovery was made less than half a century ago. Dishes, sinks, surgical instruments, furniture, ashtrays, turbine blades, saucepans, heads of golf clubs, handrails, bacon slicing machines, and lots of ornamental fittings, are made of this stainless steel. Most of the stainless steel used for cutlery contains between 12 and 14 per cent of chromium. For many industrial purposes, where the steel must be tough, stainless steel contains about 18 per cent of chromium and 8 per cent of nickel.

An important property possessed by steel, but not by mild steel, is that of resisting corrosion. This resistance is brought about by the addition of chromium

into the ordinary steel. A stainless steel is, therefore, an alloy steel, and might be known as a chrome steel.

Ordinary steel to which no other alloy has been added is called a straight carbon steel. The addition of nickel makes the steel much stronger and tough. The addition of chromium within certain limits makes for strength, but too much chromium makes the metal brittle and it will snap easily.

The correct mixtures for steel are, of course, a matter for the expert metallurgist. The addition of manganese to steel makes the steel hard and able to resist abrasion ; in fact, a hard manganese (steel with 12 to 14 per cent in it) is extremely difficult to machine.

Steel containing between 7/10ths and 1 per cent of carbon can be made into excellent tool steel by the addition of from 14 to 18 per cent of tungsten. Tungsten is an expensive material, and it is for this reason that tool steel, such as is used for first class twist drills, milling cutters, file cutters, special punches and wood saws, might cost ten or twenty times as much as ordinary rolled steel sections, such as round bars, angles and beams, which are straight low-carbon mild steel.

Amazing progress has been made during the last twenty-five years, in fact, even during the last five years, in the production of special alloy steels, such as are required for the automobile and aircraft industries, and just a few of the alloy steels made are chrome steel, tungsten steel, nickel steel, nickel-chrome steel, chrome-vanadium steel, molybdenum steel, silicon steel, copper steel and chrome-molybdenum steel.

Each of these group classifications can be sub-divided and each has its own particular properties. The silicon steel, for instance, has a very high elastic limit, and for this reason some of the world's largest bridges have been built of silicon steel, because the weight of the steel itself is less than if ordinary rolled steel were used.

A manganese steel is very hard wearing and very hard to machine. Its cost is high. It is probably the best material to use for dredger buckets and the jaws of the machines used for crushing rock and stone. It is also used for the points and crossings on tramlines, where the wear would be excessive unless special steel was put in.

Tungsten steel has the remarkable property of remaining hard after it has been heated to temperatures so high that ordinary carbon steel would be soft. For this reason twist drills and cutting tools are made in tungsten steel.

We have now seen how cast-iron, wrought iron, and steel are made, and at this stage we cannot do better than "sum up" the three materials.

Cast-iron is relatively cheap to produce, and for this reason is much used for stoves, columns, grates, rainwater pipes, machine frames and manhole

covers. It cannot be forged, welded, or tempered. It is brittle and snaps without warning. Cast-iron is between 92 and 95 per cent pure iron, and in addition to 3 to 4 per cent of carbon contains other impurities. During the last ten years much improvement has been made, both in the strength and other properties of cast-iron.

Wrought iron can be bent and twisted and easily forged when made hot, and for this reason, it is used for making certain chains, railings, ornamental gates, lamp standards and horse shoes. A good wrought iron will be more than 99 per cent of iron and the carbon is generally less than $\frac{1}{2}$ per cent.

Steel is really pure iron which has been melted and to which carbon and other alloys have been added. Carbon steel is a steel to which carbon, nickel, chrome, or other alloy have been added. Mild steel is very ductile and can be bent. Unlike wrought iron, mild steel contains in addition to pure iron, phosphorus, sulphur and manganese. Mild steel is very similar to wrought iron, and in recent years has largely replaced it. Structural steel, in the form of round bars, angles and joists, is made from mild steel which has a breaking strength of from twenty-eight to thirty-three tons per square inch. Mild steel can be easily forged.

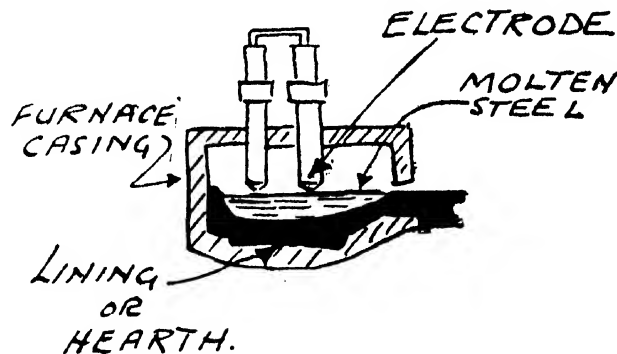

CLASSIFICATION OF STEELS

Carbon Steels are generally classified as dead soft if carbon is under 0.1 per cent.

Mild Steel if carbon is between 0.1 and 0.25 per cent.

Medium Steel if carbon is between 0.25 and 0.6 per cent.

Hard Steel if carbon is between 0.6 and 1.2 per cent.

Extra Hard Steel if carbon is more than 1.2 per cent.

Steel which contains less than 0.1 per cent of carbon cannot be hardened by heating and rapid cooling. If the carbon contained in the steel is more than

ROOF DETAILS

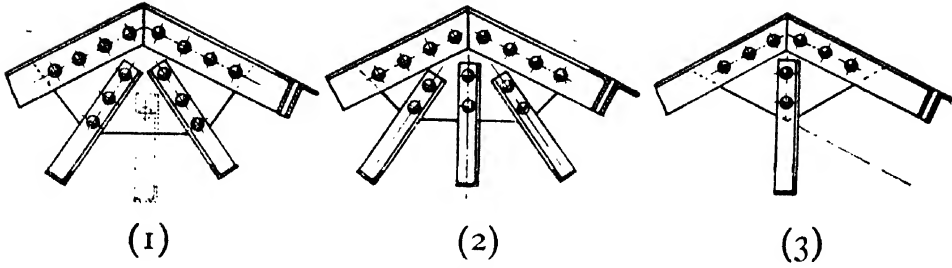

CROWN JOINTS

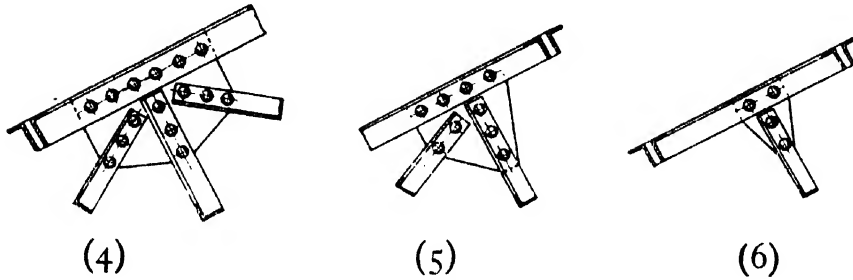

RAFTER AND STRUT JOINTS

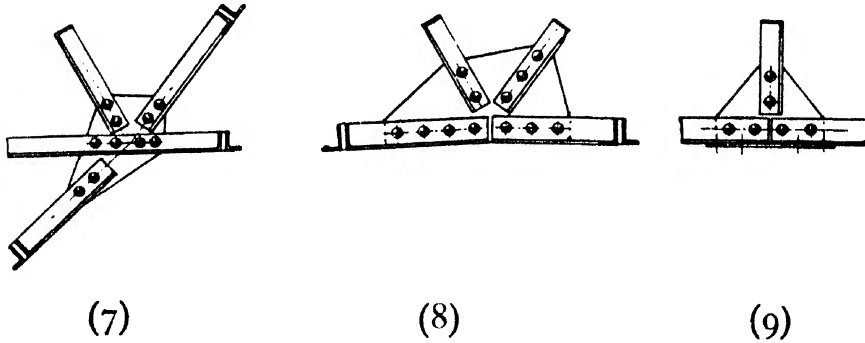

BOTTOM CHORD JOINTS

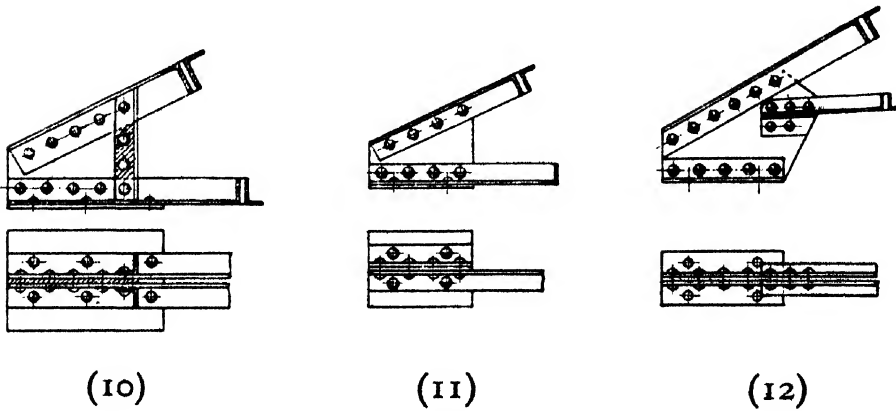

SHOE DETAILS

0.15 per cent it can be hardened by heating and rapid cooling. An increase in the amount of carbon in steel causes an increase in the tensile strength and hardness but it also causes a reduction in the ductility and toughness of the steel.

QUESTIONS ON CHAPTER VI

What is an open hearth furnace?

What is (1) mild steel, (2) medium steel, (3) hard steel?

What is an alloy steel?

What is straight carbon steel?

What are the properties of manganese steel?

CHAPTER VII

ELASTIC PROPERTIES OF MATERIALS

Technical Terms—Stress—Strain—Modulus of E—Yield Point—Elasticity.

IT might be well at this stage to consider some of the properties of materials. Most materials used in engineering and building are elastic. It is easy to see that if a block of rubber four inches square and six inches high carried a 56 lb. weight, as shown in the diagram on *Plate 7*, the block shortens in height. When the weight is removed the rubber returns to its original height of six inches. The actual change of length due to the loading can be measured without a great deal of difficulty.

SHORTENING BLOCKS

If, instead of a rubber block, we used a wood block or a concrete or steel block of exactly the same dimensions, and loaded each one with a fifty-six pound weight, each block would shorten when the weight was applied, and each would return to its original length when the weight was removed. The difference between the various materials is that although they all possess the same property, they do not possess it to the same extent. It is probable that the wood block would shorten more than the concrete block, which in turn would shorten more than the steel block. The amount by which they shorten is called the alteration of length, and if we divide this alteration of length by the original length of the block we get the term which is known as "strain."

$$\text{Strain} = \frac{\text{alteration of length}}{\text{original length}}$$

A great many tests have been made on all kinds of materials to find out their elastic properties, and we now know within reasonable limits what shortening we can expect under a given load and what lengthening we can expect if the particular material is in a state of tension under a load trying to lengthen it.

If a round bar of 1 in. in diameter has tensile load of 8 tons, we say that the stress of the bar is :

$$\text{Stress} = \frac{\text{load}}{\text{area}}$$

$$\text{Stress} = \frac{8}{\text{area of 1 in. dia.}}$$

$$\text{Stress} = \frac{8}{.7854} = 10.2 \text{ tons per sq. in.}$$

The measure of the elastic properties of a material is known as the modulus of elasticity. If we had a long rod of mild steel with a hook at the top and a hook at the bottom we could find exactly how much various weights would cause this bar to stretch.

From many previous tests and experiments which have been made we should expect that if the suspension bar was one inch square a load of one ton would stretch the bar 1/13,000th part of its length. A load of two tons twice as much. Loads of three, four, five, six and probably up to fifteen tons would stretch the bar in direct proportion to their amounts. Thus a load of ten tons on a bar one square inch in area would probably stretch the bar 1/1,300th part of its length, so that if we measured an original length of thirteen inches we should expect to find by very accurate measuring with a special machine known as the extensometer the thirteen inches would have stretched to thirteen inches and 1/1,300th part of thirteen inches. The new length would therefore be thirteen inches and 100th part of another inch. The stretch or alteration of length would be a difference between the new length and the original length, and this would amount to 100th part of an inch. This, it is true, is a very small dimension but if instead of taking an original length of thirteen inches we took a length of 130 inches (*Plate 7*) then the extension would be 1/1,300th of 130 inches which would be 1/10th of an inch, and now we are getting into dimensions which can easily be measured. If the load of ten tons put on to the bar were removed, the bar would (after a time) return to its original length. This proves its elastic property.

If we continue to increase the load we shall come to a stage when the stretch will not be in direct proportion to the load applied. This stage is called the elastic limit.

Elastic limit, yield point, and limit of proportionality are (strictly speaking) not the same thing, but for our present purpose it will be near enough to consider that they are the same.

In the case of ordinary mild steel, the elastic limit would probably be something in the region of eighteen tons per square inch. If this is so, it follows

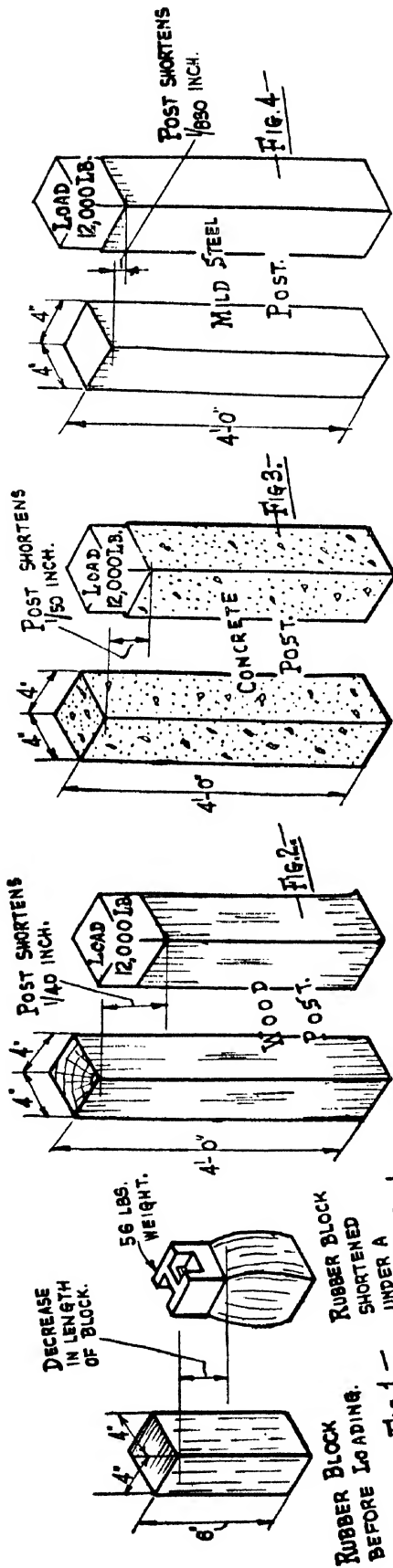

THESE SKETCHES SHOW THAT POSTS CARRYING THE SAME LOAD AND OF THE SAME SECTION AND LENGTH, BUT MADE OF DIFFERENT MATERIALS, WOULD ALL SHORTEN, BUT NOT BY THE SAME AMOUNT.

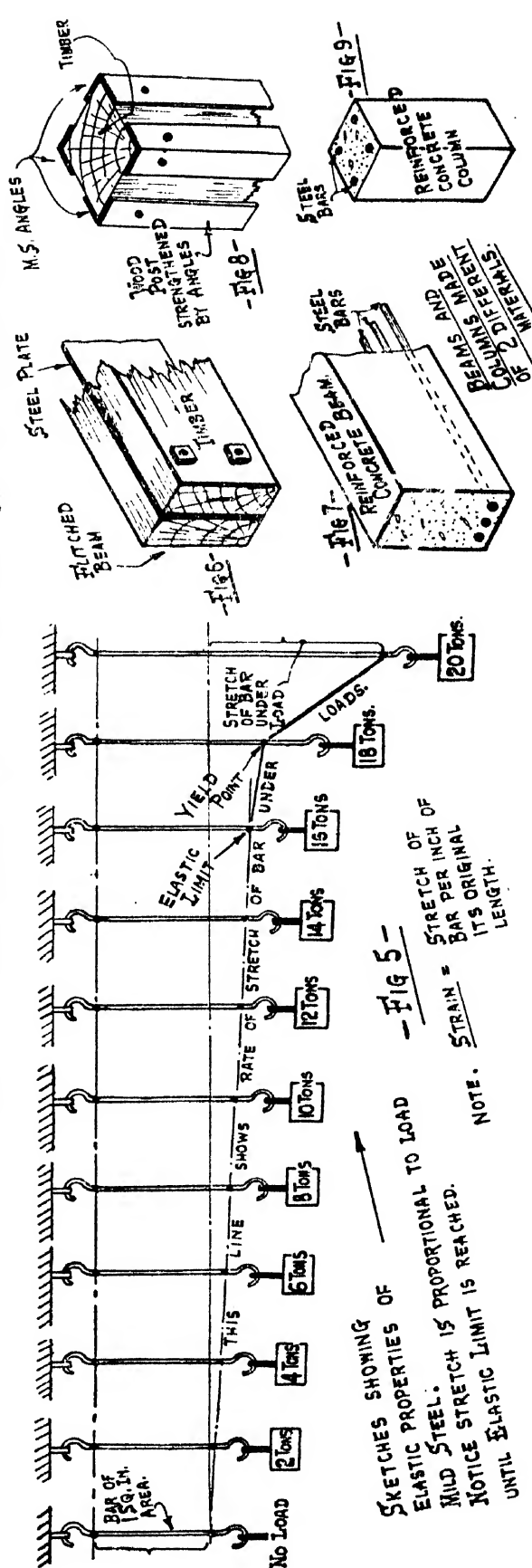

that we could have continued loading the bar so that it was carrying ten, twelve, fourteen or sixteen tons, and the alteration in length would have been in direct proportion to the load carried. In other words, when carrying sixteen tons the stretch would have been just twice as much as when the bar was carrying eight tons ; similarly, when carrying twelve tons the stretch would have been twice as much as when the bar was carrying six tons, and four times as much as when the bar was carrying three tons.

At eighteen tons the bar would probably stretch more than twice the amount it stretched at nine tons, it follows that somewhere near to the eighteen ton load a considerable change in the elastic properties of the bar has taken place. It has passed through what is known as the yield point, and the stretch is no longer in proportion to the load carried.

We draw particular attention to this point because it answers a question often asked, " Why is it that if it would take about thirty tons per square inch to break a bar, it is only considered safe to carry a load of about seven and a half tons a square inch ; that is, about a quarter of the breaking load ? " Many people feel that it should be safe if the load is not more than half the breaking load. This is a false idea.

If you have got a clear picture of what yield point and elastic limit really mean, you will see that it would be extremely risky to allow loads or stresses of anything like fifteen tons a square inch, as this would be getting very near to the elastic limit. Again, the exact amount of load coming on to a structure is seldom known. It might be estimated that a road or railway bridge will carry a certain weight, and in ten years' time the bridge might be carrying considerably more weight. If it has not been properly painted and looked after some of the steel may have rusted away. Therefore, if the stress in the steel was near to the elastic limit when the bridge was first designed, it follows that it would be past the elastic limit when carrying the increased load on material, part of which had rusted.

Naturally the elastic limit of various materials varies within very wide limits. We know that for ordinary mild steel a load or stress per square inch of 30,000 lb. would probably cause a stretch of 1,000th part of the original length ; thus a bar ten inches long with a tensile stress of 30,000 lb. would probably stretch to 10.01 inches, if the bar was 100 inches long it would probably stretch to 100.1 inches, that is, it would lengthen one tenth of an inch. Not a lot, you might say, but what about cracking in a reinforced concrete building ?

ELASTIC PROPERTY

This property, and the fact that we know how much a bar will stretch under a load, is of the greatest importance. We know perfectly well that it

would be impossible to stretch a mild steel bar to twice its original length without breaking it, but in order to get some common scale by which to calculate the extension which would take place, we use the term "modulus of elasticity" and this really means the force which would stretch a bar to twice its original length if the bar did not lose its elastic property.

That sounds simple enough, but the writer knows only too well from many years' teaching experience that a statement made in the course of a lecture is very often not understood. At the risk of being a little boring, we shall elaborate a bit on this modulus of elasticity.

The modulus of elasticity enables us to calculate how much the bar would stretch under a given unit stress, since the stress is proportional to the load, until the elastic limit is reached. If 30,000,000 lb. per square inch would stretch the bar to twice its original length, if its elastic properties held good, then 30,000 lb. per square inch would actually stretch the bar.

$$\frac{30,000}{30,000,000} = \frac{1}{1,000} \text{ of its length}$$

In other words, a stress of 30,000 lb. per square inch on a mild steel bar would probably cause an alteration of length of 0.001 inch for each inch in length.

From these points it will be clear that if we know the modulus of elasticity for a material, we can find how much it will lengthen or shorten under a given stress, provided the stress is not greater than the elastic limit of the material.

Many tests have been made, and roughly speaking, we know that the modulus of elasticity for average timber is about 1,500,000 lb., for concrete it can be assumed to be 2,000,000 lb., and for most grades of steel the modulus of elasticity is about 30,000,000 lb. per square inch.

I can well imagine you saying, after having waded through all this, what good is it any way? We shall see.

Consider three posts each four inches square and four feet high; one of steel, one of concrete, and one of wood. Each post carries a load of 12,000 lb. (roughly five and a half tons), how much will each post shorten when loaded?

Answer :

$$\begin{aligned} \text{In all cases stress} &= \frac{\text{load}}{\text{area}} \\ \text{stress} &= \frac{12,000}{4 \times 4} = \frac{12,000}{16} = 750 \text{ lb. per sq. in.} \end{aligned}$$

Case 1.—Wood post (Fig. 2, *Plate 7*).

Modulus of elasticity, say, 1,500,000 lb.

Actual stress=750 lb.

Alteration of length in proportion to original length :

$$\frac{750}{1,500,000} = \frac{1}{2,000}$$

Original length was 4 ft. = 48 in.

Alteration of length will be $\frac{1}{2,000}$ of 48 in.=very nearly 1/40th of an incl.

Case 2.—Concrete column (Fig. 3, *Plate 7*).

Modulus of elasticity, say, 2,000,000 lb.

Actual stress=750 lb.

Alteration of length in proportion to original length will be the same as the relationship between the actual stress and the modulus of elasticity.

$$\text{Actual stress} = \frac{750}{2,000,000} = \frac{3}{8,000}$$

Alteration of length will be $\frac{3}{8,000}$ of 48 in.=very nearly 1/50th of an inch.

Case 3.—Mild steel (Fig. 4, *Plate 7*).

In this case the modulus of elasticity is 30,000,000 lb. per square inch. The stress is 750 lb. a square inch, and the proportion of these two is :

$$\frac{750}{30,000,000} = \frac{1}{40,000}$$

The original length was 48 in. so that this steel column would shorten about 1/830 in.

Notice that although all three columns were of the same size before they were loaded, the wood column shortens more than the concrete column, and the concrete column more than the steel column. Although it is not easy to see by eye this actual shortening, the figures which have been calculated by using the term modulus of elasticity shows definitely how much alteration in length would take place.

We make use of our knowledge of the elastic properties of materials when finding the strength of reinforced concrete beam columns, or flitch beams, in which the wood is strengthened by a steel flitch plate (see Fig. 6).

It has been shown that if we know the load and stress on a body we can find how much it will be lengthened or shortened, and in like manner if we know the amount of the lengthening or shortening, the area of the piece, and

the elastic properties, we can find what force or stress is causing that alteration of length.

How this is applied in practice will be shown in the next chapter, but in the meantime we set out below a few general formulæ :

$$\text{Stress} = \frac{\text{load}}{\text{area}} \dots \dots \dots (1)$$

$$\text{Strain} = \frac{\text{alteration of length}}{\text{original length}} \dots \dots \dots (2)$$

$$\text{Modulus of elasticity} = \frac{\text{stress}}{\text{strain}} \dots \dots \dots (3)$$

$$\text{Alteration of length} = \frac{\text{stress}}{\text{mod. of E.}} \times \frac{\text{original length}}{1} \dots \dots \dots (4)$$

Keep this clearly in mind when thinking of reinforced concrete. Here the steel and the concrete move the same amount, so the concrete stretches or shortens (change of length) the same amount as the steel.

From formula (3) :

$$\text{Stress} = \text{Modulus of E.} \times \text{Strain}$$

$$\text{Strain} = \frac{\text{Modulus of E.}}{1} \times \frac{\text{change of length}}{\text{original length}}$$

QUESTIONS ON CHAPTER VII

What do you understand by stress ?

What is elasticity of metals ?

What is elastic limit ?

Is strain a dimension ?

CHAPTER VIII

LINTOLS AND BRESSUMMERS

Lintols—Bressummers—Load to be Carried—Bending Moments—Types of Lintols—Rolled Steel Joists—Flitched Beam—Reinforced Concrete.

LET us now deal with the practical way of designing lintol beams and bressummers.

Where there are openings in walls for doors or windows, the brickwork above is generally carried either by arches or beams. When beams are used, they are sometimes called bressummers and sometimes lintols and where this distinction is made the word bressummers is used where the opening below the beam is not filled in by a fixed frame, and the word lintol is used where the space below is filled in by a fixed frame. For instance, the beam running across the top of a window frame might be called a lintol, while the beam running over an opening in which there were sliding or swinging doors might be called a bressummer. Actually, in practice, the word lintol is often used for both cases. The important thing to realise is that whether bressummer or lintol is the word used, it is a beam for carrying the weight of the wall over an opening.

ARCHES AND BEAMS

From the point of view of building mechanics, the main difference between an arch and a beam is that in the case of the arch there must always be outward thrusts at the supports or abutments, while with the beam the load will cause only vertical reactions in normal circumstances. It is an important point which should be kept in mind, and it will be referred to more fully later.

Several forms of lintol beams are shown in *Plate 8*, and it will be seen that they are made of rolled steel sections, wood beams, cast-iron beams, flitched beams, and reinforced concrete. The drawback to wood beams is, of course, that they have not the fire-resisting qualities of the other materials, but unless the building is generally made of fire-proof construction, this is no objection, and in many localities where wood is easy to get, or where the architectural features make it desirable, wood lintols are frequently used.

It is not a difficult job to design lintols, only an elementary knowledge of bending moments, shearing forces and strength of materials being required.

The principles of simple bending moments and shearing forces are fully explained in my book *Practical Building Mechanics* (Chapman and Hall).

Actually, the amount of load which a lintol has to carry is somewhat uncertain. Where there are no windows immediately over the lintol beam, and where the distance from the opening to the end of the brickwork is more than half the span of the beam, it is generally assumed the lintol must be made strong enough to carry the weight of brickwork contained within a triangle which has a base equal to the width of the opening and sides, which slope at 60 deg. This is shown at A in Fig. 1 (*Plate 8*).

The height of the triangle of brickwork is easily found, for if S is the opening, then :

$$H = \frac{S}{2} \times \tan 60^\circ = 0.866 S$$

This is very nearly seven-eighths of the span.

Let w be the weight per superficial foot of brickwork. This is something between 9 lb. and 10 lb. per inch of wall thickness.

If w is the weight per superficial foot, then the total weight of the triangle of brickwork can be represented by W. The area of the triangle is half the base multiplied by the height.

$$\text{Area} = \frac{S}{2} \times \frac{H}{1} = \frac{S}{2} \times \frac{0.866 \times S}{1}$$

$$\begin{aligned} \text{Weight of triangle of brickwork} &= \frac{S}{2} \times \frac{0.866 S}{1} \times \frac{w}{1} \\ &= .433 \times S^2 \times w \end{aligned}$$

Example :—If a lintol beam spans over an opening of 10 ft. and supports a brick wall 9 in. thick, what will be the weight of the triangle of brickwork that the lintol carries ?

$$\text{Weight} = .433 \times S^2 \times w$$

In this case S is 10 ft., w is 85 lb. or say $\frac{3}{4}$ cwt.

$$\text{Then weight} = .433 \times 10 \times 10 \times \frac{3}{4} \text{ cwt.} = \frac{130}{4} = 32.5 \text{ cwt.}$$

It will be immediately seen that if the beam is loaded by a triangle of brickwork, the load increases from the ends of the beam to the centre and the formula for finding the maximum bending moment in such a case is :

$$BM = \frac{W \times L}{6}$$

Where BM is the bending moment in ft.-lb.

L is the span of opening in ft.

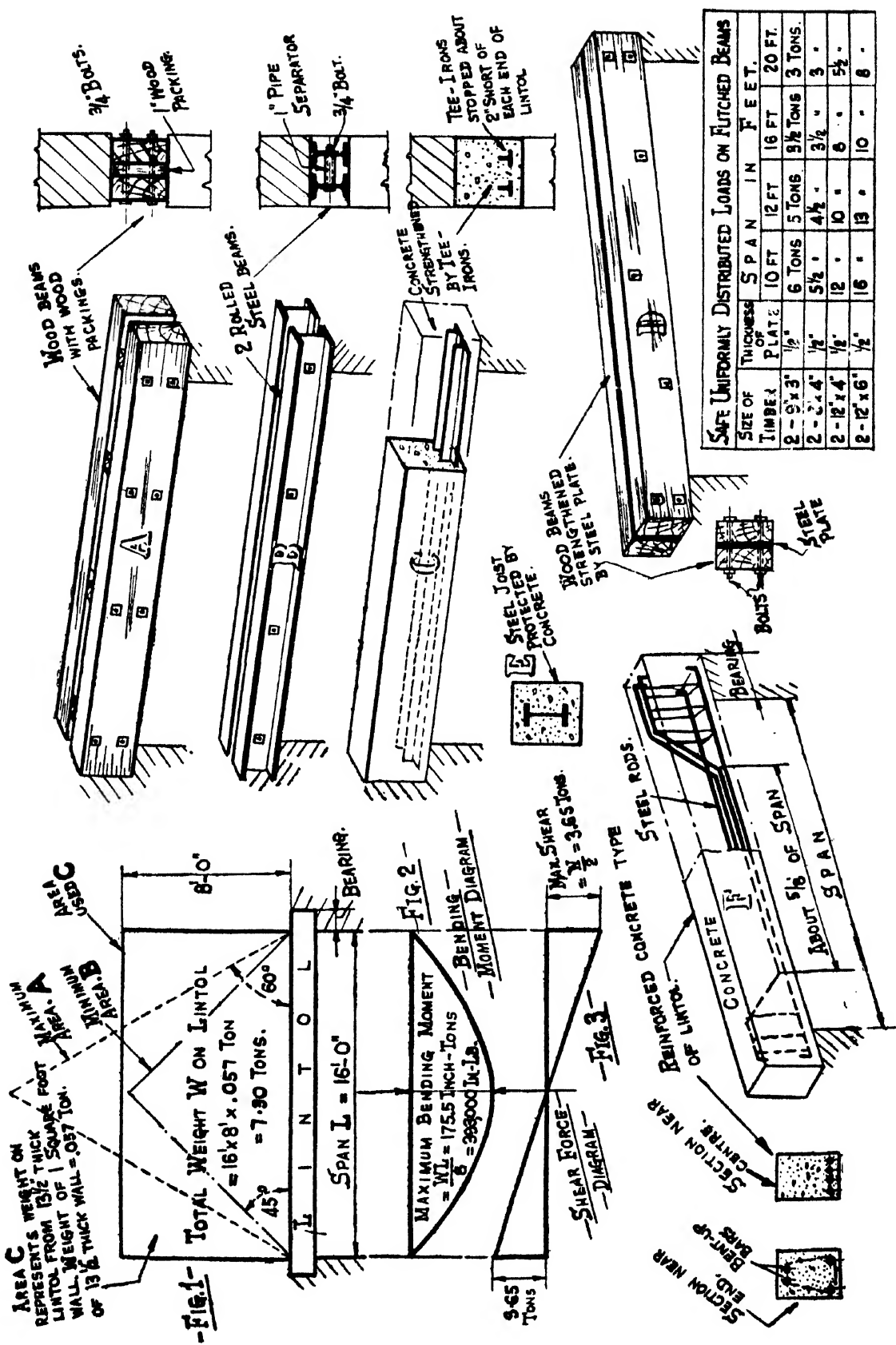

W is the total weight of brickwork carried in lb.

We have already seen that the weight of brickwork W is :

$$W = 0.433 \times w \times S^2$$

$$BM = \frac{(0.433 \times w \times S^2) \times L}{6}$$

If the bending moment is to be in in.-lb. then :

$$BM = \frac{(0.433 \times w \times S^2) \times L}{6} \times 12$$

It is important to notice that if w , the weight of brickwork per superficial foot, is taken in cwt. the bending moment will be in in.-cwt. and not in in.-lb.

S and L are both the span of the beam and the above formula can be reduced to :

$$BM = 0.866 \times w \times S^3 \text{ or } BM = 0.866 \times w \times L^3.$$

Another method of finding the weight which the beam has to carry is to consider the triangle substituted by a rectangle of brickwork. If the height of this rectangle is made half the span, the area will be :

$$S \times \frac{S}{2}, \text{ and the weight will be : } W = S \times \frac{S}{2} \times w$$

In this case the load is uniformly distributed over the length of the beam so that $BM = W \times \frac{L}{8}$

Substituting we get :

$$BM = \frac{(S \times \frac{S}{2} \times w) \times L}{8} \text{ ft.-lb.}$$

$$BM = \frac{(S \times \frac{S}{2} \times w) \times L}{8} \times 12 \text{ in.-lb.}$$

But L and S are equal :

$$BM = \frac{(L \times \frac{L}{2} \times w) \times L}{8} \times 12 \text{ in.-lb.}$$

$$BM = 0.75 \times w \times L^3 \text{ in.-lb.}$$

This is the maximum bending moment which would occur at the centre of the lintol beam if it was loaded with bricks having an area of a rectangle

with a height equal to half the span, and it will be seen that this is less than the bending moment which results from a triangle of bricks shown in Fig. 1. (*Plate 9.*)

Sometimes an area with angles of 45 deg. at the base and 90 deg. at the apex are assumed. In this case the load will be less than that shown in Fig 1. It is sound to assume the loading area as shown in Fig. 2. In Fig. 3 it will be seen that there are openings in the brickwork above the lintol and the area of brickwork may be as shown in Fig 4. (*Plate 9.*)

Look for a moment at Fig. 6 and it will be seen that if the lintol sagged too much the brickwork immediately over the lintol may follow it down, causing the wall to crack as shown by the thick lines. If these conditions arose, the brickwork above the crack would be really carried on a rough sort of arch. The vertical load on an arch causes a thrust or push on the abutments, and if the wall on either side of the opening was too weak, this thrust would probably cause the wall to bulge out as shown by the dotted lines, and a complete collapse may result.

In order to make sure that this sort of thing does not happen, it is wise to make the lintol sufficiently strong to ensure that there is no undue sagging or deflection, and with this in mind the load which the beam was designed to carry is increased. Therefore, when the width of the brickwork on either side of the opening is less than half the width of the opening, the area of brickwork which is assumed to be carried by the beam is a square. This is shown in Fig. 5. It naturally follows that if the beam is designed to carry this amount of wall which is exactly twice the amount of wall shown in Fig. 2 the lintol will be very much stronger. There will then be very little likelihood of the beam sagging as shown in Fig. 6. Consequently the brickwork is not likely to crack. If the lintol is sufficiently stiff to prevent the wall cracking, as shown in Fig. 6 the load will pass vertically down the wall and there will be no outward thrust tending to bulge the wall out. (*Plate 9.*)

Various forms of lintols commonly used are shown in *Plate 9.* Fig. 7 is a cast-iron lintol. Notice that because cast-iron is strong in compression and weak in tension, the top flange is made very much smaller than the bottom flange. At the support stiffening ribs are put in.

Fig. 8 shows a lintol formed of two rolled steel channels, the space between them being filled with concrete.

Fig. 9 shows a simple lintol made of two steel angles. This type is often used for small spans on 9 in. walls.

Fig. 10 shows a lintol formed of two rolled steel joists with gas-pipe separators. The floor beams rest directly on these lintol beams.

Fig. 11 is a rolled steel joist encased in concrete.

Fig. 12 a fitch beam lintol, is formed of two timbers with a steel plate about half inch thick running the full length of the beam.

Fig. 13 is a reinforced concrete lintol.

QUESTIONS ON CHAPTER VIII

What is a lintol beam ?

What are lintol beams made of ?

Make a sketch showing how much wall a lintol beam carries.

Sketch three kinds of lintol beams.

CHAPTER IX

LINTOLS AND BRESSUMMERS (*continued*)

Design of Lintols, using Rolled Steel Beams—Design with Concrete Strengthened with Tee-Irons—Design using Concrete Reinforced with Bars.

LINTOLS AND BRESSUMMERS

IT has already been shown that lintols spanning over doorways and other openings were called upon to carry a certain proportion of the weight of the bricks above them. Consider (*Plate 9*) Fig. 1. It was stated that some authorities assume that the lintol shown must be designed to carry a weight of brickwork indicated by the triangle A, which has sides inclined at 60 deg. to the horizontal. Other authorities assume a triangle with angles inclined at 45 deg. as shown at B. The difference between these two triangles is marked, and for practical design an area such as C can be taken. This is a rectangle with a height equal to one half the span of the lintol.

It is important to remember that these areas, A, B, C, can only be used to design a lintol where there is an amount of brickwork on each side of the lintol exceeding one half of its span. If there is an amount of brickwork less than one half of the span on either side of the lintol, this area of brickwork must be increased, thus increasing the weight of the wall carried by the lintol, and therefore the required size of the beam. Also it is assumed that there are no windows directly over the lintol in Fig. 1. The presence of these windows would also increase the weight of the wall it is assumed the lintol carried.

To design a lintol several points should be kept in mind. First, the lintol beam should possess a resisting moment equal to or exceeding the bending moment on the beam due to the loading. If not, then there is a danger of the lintol failing by bending in the centre and causing cracks in the wall, and the lintol.

Second, the safe shear stress in the material (from which the lintol is made) should not be exceeded. If so, the lintol is liable to fail by shearing off at the supports, letting the brickwork over the beam fall down.

The third, the deflection of sag of the beam should not be excessive, or the bricks above the beam will tend to crack.

Fourth, the width must be sufficient to enable the required thickness of wall to be built over the lintol.

Fifth, the most economical section depends on the relative weights and costs of the materials adopted.

Sixth, there must be enough bearing area at the end of the beam where it rests on its supports to see that the load is distributed over a sufficiently large area to prevent crushing of the support or the beam at this point.

We shall now proceed to design a lintol. Design suitable lintols to carry a $13\frac{1}{2}$ in. brick wall over a 16 ft. opening (see *Plate 8*, Fig. 1). There is more than 8 ft. of brickwork on either side of the opening, and there are no windows directly above the lintol. Neglect the weight of the beam itself.

Answer : The maximum bending moment on a beam carrying a uniformly distributed load and assumed freely supported at each end.

D is the depth of beam in inches.

F is the safe bending stress in timber.

According to the type of timber used, the value of F will alter, but for pine half-ton per square inch is about average.

$$\text{B.M.} = \frac{\text{Load} \times \text{Span}}{8}$$

$$\text{B.M.} = \frac{7.3 \text{ tons} \times 16}{8} = 14.6 \text{ ft.-tons}$$

$$\text{B.M.} = 14.6 \times 12 = 175.5 \text{ in.-tons}$$

$$\begin{aligned} \text{B.M.} &= 175.5 \times 2240 \text{ in.-lbs.} \\ &= 393,000 \text{ in.-lbs.} \end{aligned}$$

Then $RM = BM$.

$$\frac{B \times D^2}{6} \times \frac{1}{2} = 175.5 \text{ in.-tons}$$

$$BD^2 = 175.5 \times 6 \times 2 = 2106.$$

If we make the beam of two timbers each 6 in. wide with 1 in. packings between them, this will provide a width of 13 in. which is suitable to build the wall on.

Then $B = 12$ in. and $12D^2 = 2106$

$$D^2 = \frac{2106}{12} = 175$$

$D = \sqrt{175} = \text{say } 13 \text{ inches.}$

Two timbers, 6 in. by 13 in. with 1 in. packings are suitable as regards bending stresses. On spans such as this the shear stress is usually low, but it is a good point always to check up to see it is not exceeded.

Maximum shear stress for beam of rectangle section inch-pound per square inch :—

$$\begin{aligned} &= \frac{3}{2} \times \frac{\text{max. shear in.-lb.}}{\text{area of beam}} \\ &= \frac{3}{2} \times \frac{3.65 \times 2240}{12 \times 13} \\ &= 79 \text{ lb. per square inch.} \end{aligned}$$

The allowable safe stress in shear for timber averages about 150 lb. per square inch, so that the beam is quite safe.

There must be a sufficient bearing area of the lintol on the supports to see that the beam does not sink into the walls. Reaction at wall = 3.65 tons. Safe bearing pressure on brick set in cement and lime mortar = say, 10 tons per square foot approx.

$$\text{Required bearing area} = \frac{3.65}{10} = .365 \text{ sq. ft.} = 53 \text{ sq. in.}$$

$$\text{Width of beam} = 12 \text{ in.}$$

$$\text{Bearing length} = \frac{53}{12} = 4\frac{1}{2} \text{ in.}$$

In practice, the bearing length would be made 6 in.

DESIGN B. (ROLLED STEEL BEAMS)

If a steel beam is preferred, its design will require the designer to possess one of the handbooks giving the properties of the standard sections rolled by British steelmakers.

The resisting moment of a R.S.J. = modulus \times F. Where modulus is the area of one flange \times depth of beam approx.

F = safe bending stress which can be taken at 8 tons per square inch in ordinary conditions.

$$\text{And as RM} = \text{BM then modulus required} = \frac{\text{BM}}{\text{F}} = \frac{175.5}{8} = 21.9 \text{ in.}^3$$

It has been stated that to avoid excessive deflection the depth of the lintol must be at least 1/24th of the span, in this case :

$$\frac{1}{24} \times 16 = \frac{2}{3} \text{ ft.} = 8 \text{ inches.}$$

Reference to steel section makers' handbooks will show that the smallest section 8 in. deep is the 8 in. \times 4 in., having a modulus of 13.9 in.³. Two such joists will have a total modulus of 2 \times 13.9 = 27.8 in.³, and these can be used.

It is as well to check up to see that the joists are safe against failure of their webs in the shear. The safe shear stress on a web of a joist can be found by the formula :

$$\text{Safe shear stress} = 5.5 - \frac{d}{25t} \text{ tons per sq. in.}$$

where d is the depth of web = 7.2 inches,
and t is thickness of web = $2 \times .28$ inches.
= .56 in.

$$\begin{aligned} \text{Safe shear stress} &= 5.5 - \frac{7.2}{25 \times .56} \\ &= 5.5 - .5 = 5 \text{ tons per sq. in.} \end{aligned}$$

$$\text{Actual sheer stress} = \frac{\text{max. shear}}{\text{area of webs}} = \frac{3.65 \text{ tons}}{(7.2 \times .56)} = .90 \text{ tons per sq. in.}$$

The joists are therefore quite safe against failure in shear.

The flanges of the joists at the end of the lintol where it rests on the wall give a total bearing width of $2 \text{ in.} \times 4 \text{ in.} = 8 \text{ in.}$ Allowing 10 tons per square foot as the safe breaking stress of the beam on brick wall set in cement and lime mortar, then (as for the timber beam) a bearing area of 53 square inches is needed, from which :

$$\text{Bearing length required} = \frac{53}{8} = \text{say } 7 \text{ inches.}$$

The two joists would be spaced at about 9 in. centres, and 1 in. pipe separators with $\frac{3}{4}$ in. bolts can be used to hold the joists together.

DESIGN C. (CONCRETE STRENGTHENED BY TEE-IRONS)

The resisting moment of a rectangular reinforced concrete lintol can be found by using the formula : $RM = 100Bd^2$ in.-lb. Where B is the breadth of the beam in inches, d is the effective depth of beam, which is the distance from the top of beam to centre of reinforcing bars.

The compressive stress in the concrete in the part of the beam above the neutral axis is limited to 650 lb. per square inch, while the tensile stress in the steel is about 16,000 lb. per square inch.

$$RM = BM \quad 100Bd^2 = 393,000. \quad Bd^2 = \frac{393,000}{100} = 3,930$$

The beam is to carry a wall $13\frac{1}{2}$ in. thick. Make beam $13\frac{1}{2}$ in. wide.

$$13.5d^2 = 3,930. \quad d^2 = \frac{3,930}{13.5} = 292. \quad d = \sqrt{292} = 17.2 \text{ inches.}$$

Allowing for covering of bars, make beam 19 in. deep.

Size of beam = $13\frac{1}{2}$ in. \times 19 in. Check for shear.

Maximum shear stress on a rectangular reinforced concrete beam =

$$\frac{8}{7} \times \frac{\text{max. shear}}{\text{effective area of beam}} = \frac{8}{7} \times \frac{3.65 \times 2240}{13.5 \times 17.2} = 40 \text{ lb. per sq. in.}$$

The safe shear stress is about 60 lb. per square inch, so there is no fear of failure in shear.

The required area of reinforcing steel will be given approx. by :

$$\frac{.75 \times B \times D}{100} = 1.75 \text{ sq. in.}$$

Where B = Breadth of Beam $13\frac{1}{2}$ in.

„ D = Effective Depth 17.2 in.

Reference to any steel section maker's handbook shows that a 2 in. \times 2 in. \times $\frac{1}{4}$ in. tee has an area of .94 sq. in. Two such tees can be used and give an area of $2 \times .94 = 1.88$ sq. in.

$$\text{Required bearing length} = \frac{53 \text{ sq. in.}}{13.5 \text{ in.}} = 4 \text{ in.}$$

Make 6 in. long.

DESIGN F. (REINFORCED CONCRETE BEAM)

The design of this beam follows exactly on the lines of the concrete beam strengthened by tee-irons. As shown, at the centre of span 1.75 sq. in. of reinforcing are needed. Four round rods each $\frac{3}{4}$ in. diameter give an area of 1.76 sq. in. and could be used. These can be spaced at 3 in. centres, and the two inner bars will be turned up at an angle of 45 deg. as shown on the drawing. As the bending moment reduces when the supports are approached, a smaller area of reinforcing is required at the bottom of the beam, and also as the shear increases, the bent-up bars can be used to take care of this increased shear. This point was explained in my book on *Practical Building Mechanics*.

DESIGN D. (FLITCHED BEAM)

If the depth of the beam is limited, but it is wished to adopt timber in its construction, a flitched type of lintol may be used. This consists of two or more timbers, between which a steel plate or plates about $\frac{1}{2}$ in. to $\frac{3}{4}$ in. thick run. This has the effect of reducing the required depth of the timbers. As any reader will know who has some knowledge of building mechanics, two materials tied or bolted together must stretch or contract the same amount under any load,

and within the elastic limit the ratio between the stress in the timber and the stress in the steel will be the same as the moduli of elasticity of the two materials.

Then :

$$\frac{\text{Stress in timber per sq. in.}}{\text{Stress in steel per sq. in.}} = \frac{E \text{ of timber}}{E \text{ of steel}}$$

Where E of timber is about 1,500,000 lb. per sq. in.

E of steel is about 30,000,000 lb. per sq. in.

Then :

$$\frac{\text{Stress in timber}}{\text{Stress in steel}} = \frac{1,500,000}{30,000,000} = \frac{1}{20}$$

$$\text{Stress in timber} = \frac{\text{Stress in steel}}{20}$$

If the steel is stressed to 8 tons per sq. in.

$$\text{Stress in timber} = \frac{8}{20} = .4 \text{ tons per sq. in.}$$

Resisting moment of a rectangular timber

$$= \frac{BD^2}{6} \times \text{stress per sq. in. in timber.}$$

Where B is breadth of timber in inches.

D is depth of timber in inches.

Resisting moment of rectangular steel plate

$$= \frac{tD^2}{6} \times \text{stress per sq. in. in steel.}$$

Where t is thickness of plate.

D is depth of plate.

A 13½ in. wall is to be supported and employing a ½ in. thick plate, the timbers must have a combined breadth of 13 in.

$$\text{Then RM} = \text{BM and } \left(\frac{BD^2}{6} \times .4 \right) + \left(\frac{tD^2}{6} \times 8 \right) = 175.5$$

$$\left(\frac{13 \times D \times D \times .4}{6} \right) + \left(\frac{\frac{1}{2} \times D \times D \times 8}{6} \right) = 175.5$$

$$.88 D^2 + .66 D^2 = 175.5$$

$$1.53 D^2 = 175.5$$

$$D^2 = \frac{175.5}{1.53} = 114$$

$$D = \sqrt{114} = \text{say } 11 \text{ inches.}$$

The beam can be made of two timbers $6\frac{1}{2}$ in. \times 11 in. and a plate $\frac{1}{2}$ in. thick by 11 in. deep. A table will be found in *Plate 8* giving suitable sizes of timbers for flitched beams carrying various loads.

At E is shown another very common type of lintol consisting of a rolled steel beam protected by concrete. (*Plate 8.*)

QUESTIONS ON CHAPTER IX

What is the shear in a beam?

What is the Modulus of elasticity for timber?

What is the Modulus of elasticity for steel?

What is a flitched beam?

CHAPTER X

COPPER

Copper—Furnace—Matte—Converter—Methods of producing Refined Copper—Electrolytic refined Copper—Paling—Pitch—Effect of Alloying with Zinc—Brass—Bronze.

THE PRODUCTION OF COPPER

WHAT is “ non-ferrous ” metal ? The Latin word for iron is *ferrum*, and iron is generally represented by the letters Fe. We have seen in the previous chapters that there are many kinds of iron. Metals (which are not iron), such as lead, copper, aluminium, silver, gold and tin, are known as non-ferrous metals. The builder uses large quantities of copper, lead, tin and zinc. In years gone by some builders even possessed and exchanged golden coins.

SIXTY CENTURIES AGO

Long before primitive man used iron he was working and using copper. Probably our ancient forebears were attracted by the bright appearance of the mineral ore. It has quite a reddish colour. Copper is much softer than iron, and one can imagine that in the dim and distant past a primitive man found that by beating it with stones and bones it could be knocked into various shapes. Copper objects have been found in the ground below the clay deposit left behind in Mesopotamia after the Great Flood of forty days and forty nights which we are told covered the face of the earth. Some scholars believe that this Great Flood occurred somewhere about 4,000 years before the birth of Christ. We have good reason to believe that copper was worked in Persia, Arabia, Cyprus, and around the valley of the River Euphrates sixty centuries ago. Time marches on, but copper is still one of the most useful metals known to man, and it plays an important part in many phases of his activities. As far back as 1500 B.C. the Phœnicians knew of the mineral deposits in Cornwall.

In the British Museum there is a bull's head made of cast copper, which was found at Ur, and is supposed to date back to about 3000 B.C. The Chinese made copper bells and vessels, for water or wine, more than 1,000 years before Julius Cæsar set foot in this country.

Copper is not found and mined in solid blocks as is coal. It is found in mineral ore and the impurities have to be removed. If the mineral ore contains six tons of copper in every 100 tons of mineral taken out of the ground, it is considered to be very high-grade ore. A low-grade ore might contain less than one ton of copper for every 100 tons of mineral. Fortunately the mineral generally contains other important materials. One hundred tons of pyrites, for instance, might contain, in addition to one ton of copper, forty-eight tons of sulphur and forty tons of iron. The balance would be lead, quartz, silver, tin, zinc, arsenic and phosphorus.

The method of extracting copper from the mineral ore will depend on the nature of the mineral. We have seen in the chapters dealing with the production of iron and steel how the impurities can be eliminated by oxidisation in the furnace. Some of the plant used in the production of copper is shown in *Plate 10*. The mineral ore is crushed down to be a suitable size by passing it through some suitable type of crusher, either a jaw crusher or a gyratory crusher.

A picture of one of these jaw crushers, which works on the same principle as nut crackers, is shown in Fig. 1. The mineral is now fed into a blast furnace, and by the addition of suitable fluxes and an air blast, the ore and the flux are melted together. The gases which contain the sulphur are treated separately, and the matte, which is, of course, a liquid, is run off from the bottom of the furnace (see Fig. 2) into a settler, which is really a large tank, where the matte separates from the slag by gravity. (*Plate 10*.)

For many years copper matte was reduced to metallic copper in a reverberatory furnace. Most of this copper refining was done in South Wales, and this system is, therefore, often known as the Welsh process. This is quite an art, and men cannot quickly be trained into the practical ways of copper refining.

Metallurgical experts of forty or fifty years ago began to see the possibility of using a converter, very similar to the one used by the steel makers. We have already dealt with these Bessemer converters in the chapter on steel.

Fig. 3 shows a view of one of these converters. The air is blown in through the tuyeres, which are located near the base on the converter. Converters are lined either with special magnesite bricks or with a rammed lining, which may be made of a crushed magnesite or crushed quartz or silica.

There now seems to be a tendency to use tamped lining, which really means putting a wood former inside the converter and ramming between the former and the converter shell, small-grained materials, which set hard when fired. This is something like lining a furnace with concrete, except that the material is very much drier and has to be continually rammed while the lining is being put in.

THE ARMA.



THE ANCIENT
EGYPTIANS
SYMBOL FOR
COPPER MEANS
EVERLASTING
LIFE.

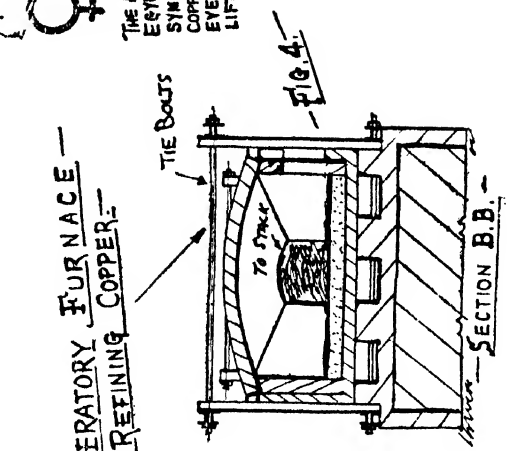

REVERBERATORY FURNACE
FOR REFINING COPPER.

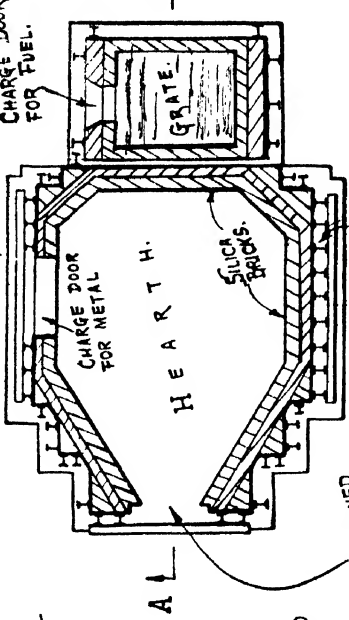
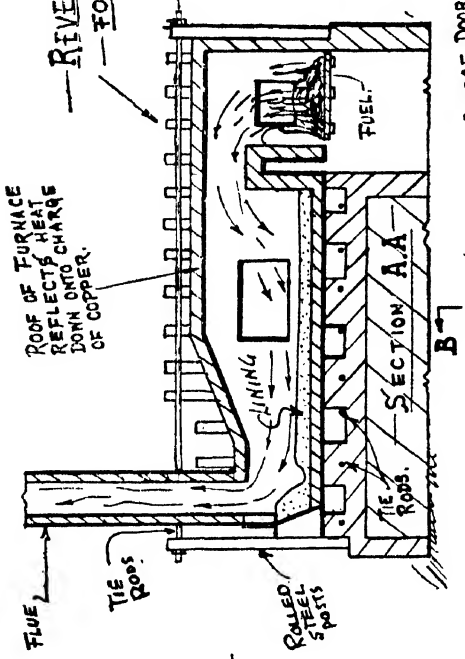

MOLTEN REFINED COPPER TAKEN IN HERE, EITHER IN LADLE OR THROUGH TRAPPING HOLE.

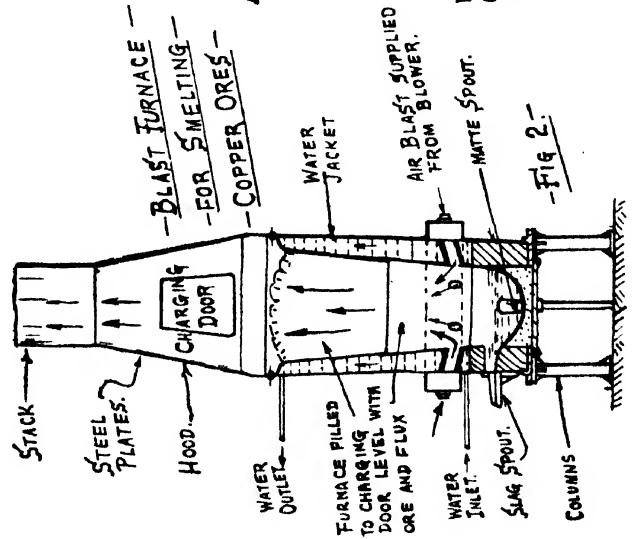
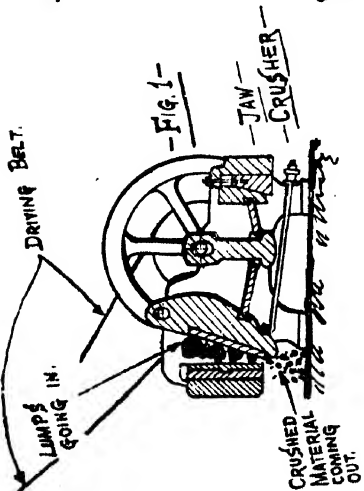

BLAST FURNACE
FOR SMELTING
COPPER ORES.

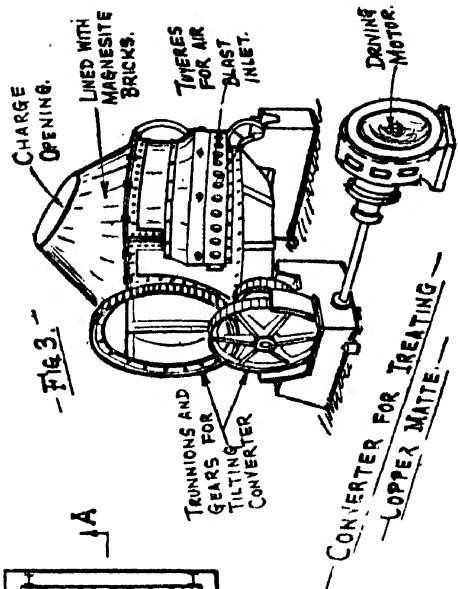

CONVERTER FOR TREATING
COPPER MATTE.

PROCESS OF CONVERTING

The process of converting is as follows :

To remove the impurities, air is kept blowing until the skilled operator can judge by the colour of the flame at the mouth of the converter that the impurities have been dealt with. The molten slag is poured off into special wagons, and either dumped on slag heaps or if it contains too much copper it is re-treated. Once the slag has been poured off, the copper is then poured into moulds, and is known as blister copper. At this stage the blister copper might contain 96 or 98 per cent of pure copper, but it still contains impurities which might be in the form of iron, silver zinc, arsenic and bismuth. These are eliminated in the next stage, which is known as copper refining.

The specification for refined copper may require that the copper be 99.9 per cent pure copper. In other words, out of every 100 tons of refined copper there must be 99 tons 18 cwts. pure copper. The remaining 2 cwt are impurities. which may be in the form of nickel, arsenic, bismuth and oxygen. Copper which is made for the purpose of drawing into very fine wire must be produced with not more than 1/10th of one per cent oxygen. When it is realised that the molten copper has to be poured into moulds, and that all the time this is being done the copper is taking in oxygen from the air, it will be realised that the molten copper as it leaves the furnace must be almost entirely pure copper.

REFINED COPPER

Refined copper is produced in a reverberatory furnace, a type of which is shown in Fig. 4. In this furnace blister copper containing 98 per cent of copper can be refined into almost pure copper. In the same furnace precipitate copper can also be refined. Precipitate copper is obtained by placing iron bars in a strong copper liquor. The iron is eaten away and the deposit left is known as precipitated copper.

The reverberatory furnace is low in height, and this gives it the name, for the word reverberate means to beat back, and this is precisely what the roof of the furnace does, because the flame from the fire at one end of the furnace is beaten down on to the charge, which thus becomes melted. The process of eliminating the impurities so that of the blister copper, which goes into the reverberatory, not more than 98 per cent copper can be taken out as 99.9 per cent containing copper, is as follows :

Through the side door in the furnace the blister bars, which weigh 2 cwt. apiece, are loaded. The doors of the furnace are closed, and the heat in the furnace, which is supplied by a coal fire at one end of the furnace, melts down the charge. The idea is to keep the furnace walls as tight as possible so that air

which contains oxygen is not sucked into the furnace. The slag which forms, floats on the surface of the molten metal. The slag can be skimmed off. The coating of cuprous oxide must be reduced, otherwise the copper will contain too much oxygen, and this makes it difficult to draw into wires, because it tends to be brittle.

The oxygen must be removed and this is done by poling. Sticks of green timber as large as can be got into the furnace are pushed through the front door into the bath of molten metal. The hydro-carbon gases reduce the oxygen content into the copper, and sometimes a covering of fine charcoal is spread to prevent further oxidisation. The molten metal, when it is "up to pitch," is removed from the furnace either through the tapping hole, which may be located in the opposite side of the furnace to the charging door, or sometimes it is taken out by ladles through the front door. The molten copper is then run into ingot or wire moulds, and as soon as the copper is set, which is a matter of only a few minutes, the mould and the copper bars are tipped into a bosh of cooling water.

Impurities, particularly arsenic and bismuth, can be a nuisance and greatly affect the characteristics of copper, particularly where used in the electrical industries. A method now very largely used is known as the electrolytic process, whereby copper of almost 100 per cent purity can be obtained, and for this kind of copper, (known as electrolytic copper), the market is prepared to pay some £5 per ton more than the copper price for ordinary refined copper.

Electrolytic deposition of copper is done in long wood tanks lined with lead. Special shaped blocks of cast copper form the anodes or positive plates, while the negative plates, or cathodes, are made of pure copper about $\frac{1}{4}$ in. thick. Both anodes and cathodes are in a dilute solution of acid (copper sulphate and sulphuric acid), and by passing an electric current through this solution the copper of the anodes (impure copper) is scaled off and deposited as pure copper on to the negative plates. Any small quantities of silver and gold in the impure copper precipitate as mud, which settles to the bottom of the tanks as a slime, while other impurities go into the solution.

By the electrolytic process a copper which is 99.98 per cent pure can be obtained. The significance of what this means will be better understood if we realise that out of every 100 tons of electrolytic copper produced, 99 tons 19 cwt. 2 quarters and 12 lb. are pure metallic copper, and that all the impurities combined amount to only about 44 lb. (less than $\frac{1}{2}$ cwt.).

Although copper is one of the softer metals, it is extremely malleable, of a reddish colour, and because of its corrosion resisting properties copper frequently is used as a roof covering over domes of churches and important

buildings. It can be rolled into very thin sheets and drawn into very fine wire. Pure copper is an extremely good conductor of electricity and for this reason it is largely used in the electrical industry for cables.

In all sorts of industries we find copper used either in the fairly pure form or as an alloy in the form of a brass or a bronze. Locomotive engineers use it for fire-boxes. Copper tubes, bolts, nuts and wire are used in many industries.

ADDITION OF ZINC

Brass is the term usually employed for alloys of copper and zinc. The range of mixture varies over wide limits, but there is always more copper than zinc. The reason for mixing or alloying zinc to copper is that copper in itself is very soft and weak in tension. The addition of zinc increases the tensile strength, provided the mixture has not more than about 40 per cent zinc. If more than this amount of zinc is added to the copper the brass becomes brittle.

What is known as cartridge brass contains 70 per cent copper and 30 per cent zinc. Red brass is about 85 per cent copper and 15 per cent zinc, and is so called because of its red colour. What is known as standard brass or alpha brass is about 70 per cent copper and 30 per cent zinc. It resists corrosion quite well, and can be worked into intricate shapes, rolled into sheets, and turned into tubes or wire. The brasses known as Muntz metal are especially suitable for castings. The mixture does not roll cold, but is very suitable for hot rolling or hot stampings.

Yellow brass is about half copper and half zinc. This is sometimes used for making brass castings. A little lead added to brass softens it somewhat and makes it more easily machined. Unfortunately it reduces the strength. Aluminium added in small quantities to brass increases its tensile strength. For this reason aluminium-brass, which is a mixture of copper, zinc and a little aluminium is used largely for marine work, where a strong non-corrodible metal is required.

Bronze is an alloy of copper and tin. Nearly all the bronzes contain 80 per cent of copper, the object of adding the tin being that it definitely hardens and strengthens the copper so long as the amount of tin does not exceed 20 per cent. Bronze was so well known and so well used by the ancients that we have a definite age in history known as the Bronze Age. We have had a Stone Age, Bronze Age and Iron Age, and perhaps, this age will be known as the Plastic Age. Sometimes zinc and sometimes lead is added to make the mixture suitable for a special purpose.

Copper is heavier than iron and lighter than lead, weighing about 550 lb. per cubic foot.

The ancient Egyptians knew the extraordinary qualities of copper, and it is therefore not surprising that the symbol used for copper, known as the Ankh, is a cross suspended from a circle which means "everlasting life."

QUESTIONS ON CHAPTER X

What is a non-ferrous metal?

Is copper softer than iron?

Where was copper first used and when?

What is a reverberatory furnace?

How is the purest copper made?

Can copper be rolled into very thin strips?

Can copper be drawn into very fine wire?

What is (1) brass, (2) bronze?

What is the effect of alloying zinc with copper?

What is the weight of a cubic foot of copper?

What is electrolytic copper?

CHAPTER XI

LEAD, ZINC, NICKEL, CHROMIUM

Iron Perrons—Metals—Galena—Discovery of Lead—Furnace—Matte—Solder—Red Lead—Litharge—Zinc—Nickel—Chromium.

THE principal non-ferrous metals are copper, aluminium, zinc, tin, lead, nickel, and chromium.

Lead is found as an ore and is mixed with impurities such as arsenic, bismuth, nickel, cobalt, tin, iron and sulphur, and these impurities have to be removed before a good commercial lead can be made. Nearly all lead is got from an ore containing lead-sulphide. This is known as galena. In the old days of wireless sets using the cat's whisker, the crystal was often galena.

DISCOVERY OF LEAD

Long before the Christian era, lead was known and used. When it was first discovered is not known, but it was certainly used by ancient Egyptians, Greeks, and Romans, and records show that as far back as 800 B.C. the King of Assyria took tribute from a conquered nation in the form of a galena. The Romans did quite an amount of lead mining both in Britain and Spain about the time of Julius Cæsar. Lead ores are now found in many parts of the world. Often lead ore, as mined, contains only five or six tons of lead in 100 tons of material mined.

The lead ore is generally roasted before being smelted. The purpose of roasting is to reduce the sulphur content in the lead ore. In the roasting a current of ore is passed through the material, which has been previously finely crushed. This oxidises the metal and agglomerates or builds together the material in the form which makes it suitable for the blast furnace or reverberatory furnace.

Although lead is a very easy metal to reduce from its ores, it is difficult to recover all the lead in a pure form. On broad lines the reverberatory furnace *Plate 11, Fig. 1* used for lead is the same as for copper. The fine roasted ore is charged into the hot furnace and spread over the floor. The ore is turned and spread on the furnace hearth to make the roasting even, before the final melting stage starts. As the molten lead begins to flow it is tapped out of the furnace.

A skin of material flows on top of the lead and this is "set up to pitch" by mixing it with lime. The slag from the furnace sometimes contains sufficient lead to merit another smelting in a separate furnace.

The blast furnace for smelting lead ores is shown in Fig. 2. The fuel used is often coke. Iron and iron oxide are added to the blast furnace to form reducing and fluxing agents, and lime is also used as a flux and to reduce the sulphur. The lead is ladled, and goes into moulds, and this pig-lead, which often contains silver, antimony, copper and arsenic, is then taken to the refining furnaces, because lead for the market must be practically 100 per cent pure.

The final refining is done in reverberatory furnaces. Along with the lead, the blast furnace produces a matte and a slag. In this matte there will be practically all the lead which was present in the original ores. There will also be some lead-sulphide and some gold and silver, if these were present in the original ore. The matte is roasted and re-smelted in order to recover these precious metals, if they are present in sufficient quantities to merit the expense.

SOFTEST METAL

Blue-grey in colour, lead has a clean surface when freshly broken. The metallic shine disappears after being exposed to the air for some time. Being the softest of the metals in common use, lead flows rapidly under pressure, and can be pressed or hammered into quite complicated shapes. Although lead cannot be drawn into very fine wires, as copper can, it can be rolled into very thin sheets. Many of the tea-chests are lined with lead foil to protect the tea from becoming wet during its ocean voyage.

In building work lead sheets are used for flashing around chimney stacks, the lining of gutters (see Fig. 3), and for the covering of roofs and skylights. Lead rolled into sheets is also used for the lining of pipes. Lead does not corrode, and resists many acids. For this reason it is much used for lining pipes which convey liquors containing acids, and the impellers of pumps are sometimes made either of lead or the pipes are lined with lead to protect the iron casting from corrosion. Pewter work is very well known, and this is made of a mixture which contains between 15 and 20 per cent of lead and 85 and 80 per cent of tin. Plumbers know that lead is much used in red lead paints for the protection of iron and steelwork.

We may remark here that red lead is one of the oldest pigments known to the painter. Pliny, the historian, mentions that the painter Nicias used red lead as a pigment about 320 B.C. In those days the paint was used, of course, for painting miniature articles. In these days huge quantities of red lead are used for the protection of important steelwork and bridges.

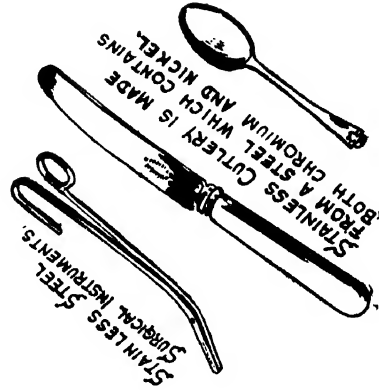
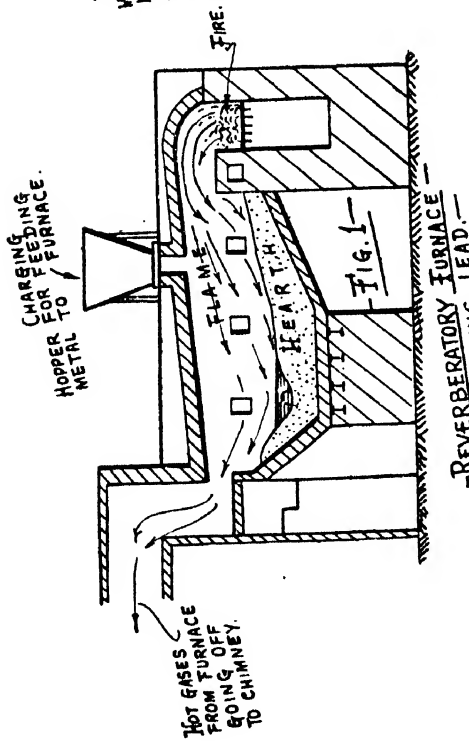
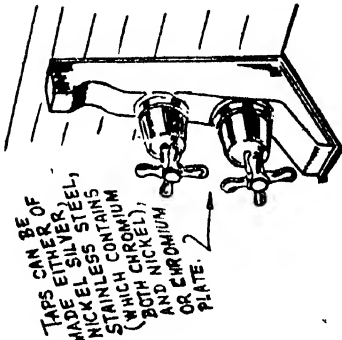
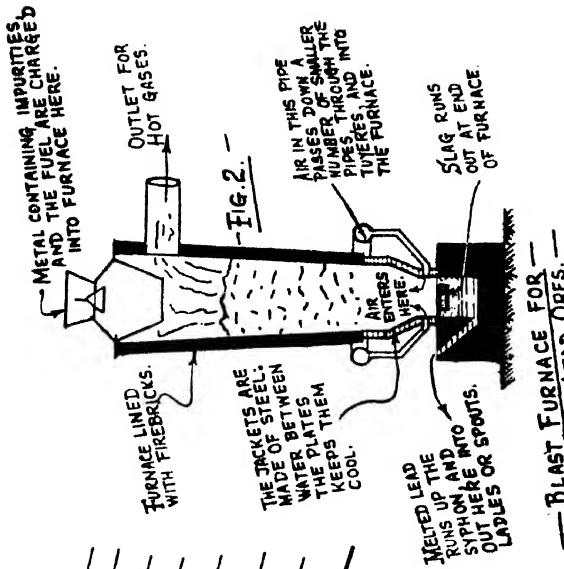

h
THE ANCIENT SYMBOL FOR LEAD.

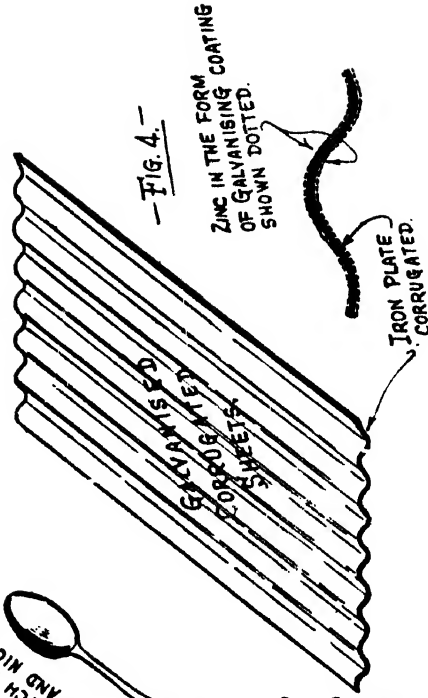
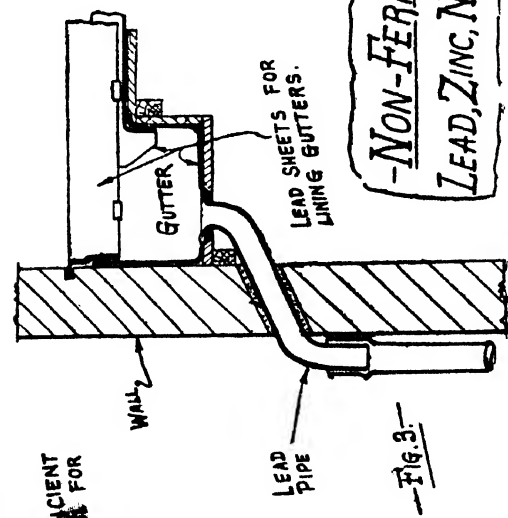

-NON-FERROUS METALS-
LEAD, ZINC, NICKEL & CHROMIUM

MELTING SOLDER

In the printing trade, lead is used in the making of type metal and for stereo plates. The plumber, builder, and almost every handyman about the house uses solder, which is generally a mixture of two parts of lead and one part of tin. When the tin and the lead are melted together, they form a new alloy. The interesting thing about the alloy is that it melts at a lower temperature than either of the two metals of which it is formed. The lead, for instance, melts at a relatively low temperature of 620 deg. F. (about 327 deg. C.). Tin melts at about 450 deg. F. (about 232 deg. C.), yet the alloy when formed as solder melts at about 360 deg. F. This makes it possible to melt the solder when joining together two lead pipes or two pieces of tin plate, without melting the lead pipes or tin plate.

Lead is a very poor conductor of both heat and electricity. When bismuth and cadmium are mixed with tin an alloy is formed which melts at the exceedingly low temperature of about 160 deg. F. and it is from this mixture that the plugs in the pipes of water sprinklers which protect buildings from fire are made. The holes in the pipes are stopped up by this low temperature-melting material, and if a fire breaks out in the building, the heat melts this alloy and allows the jets of water to sprinkle over the floor of the building. Fortunately the melting point is sufficiently high that it does not melt on a hot summer's day.

Motorists will remember that some years ago a special anti-knocking petrol was brought on to the market. This was really a petrol into which a compound of lead-tetra-ethyl was introduced. The effect of this was to make the explosion in the motor-car cylinders a little later than when the ordinary petrol mixture was used, and thus what is known as "knocking" was reduced if not eliminated.

Most of the anti-friction metals, also known as white metals, which are used for the bearings in which shafts run, contain lead. Those known as bronzes are generally mostly copper, but many of the white metal bearings are largely composed of lead.

An exceptionally pure brand of lead can be obtained if lead is refined electrolytically. The electrolytic process was mentioned in the chapter dealing with copper, and will therefore not be described here. It is sufficient to say that electrolytic lead can be produced which contains 99.98 per cent of pure lead. In other words, the lead is so pure that in 100 tons there are actually 99 tons 2,200 pounds of pure metallic lead, so that all the impurities put together weigh only about 40 pounds in 100 tons of this electrolytically pure lead. It is not suggested, of course, that ordinary commercial lead is as pure as this.

Litharge is lead oxide, generally produced by heating metallic lead in a current of air. It is used in making flint-glass. Antimonial lead, sometimes known as hard lead or type metal, is made from lead ores and is not produced from the pure metal. Generally antimonial lead carries about 17 per cent of antimony and about 2 per cent of other materials such as arsenic, bismuth, copper, etc. The effect of adding antimony and arsenic to lead is not that it makes the lead hard, but that it destroys its malleability.

Lead is one of the heaviest of metals, weighing 707 pounds a cubic foot.

Although in these days zinc is well known to builders, it is one of the more recent metals. It has only been known as a distinct metal for about 300 years, and has been produced commercially less than 100 years. It has a bluish-white colour, and takes a good polish. Zinc is both ductile and malleable between a range of about 110 deg. and 150 deg. C. Within this range it can be drawn into wire or rolled into sheets, but outside this range it is neither very ductile nor very malleable. Its melting point is about 415 deg. C. It is a poor conductor of heat and electricity. When in cake form zinc is generally known as spelter.

Although it does not alloy easily with lead, it alloys very well with most other metals, particularly copper. One of its principal uses is forming an alloy with copper, known as brass. To the builder the principal use of zinc is to form a coating for corrugated sheets, which is known as galvanising, in order to prevent them rusting (see Fig. 4 in *Plate 11*).

The process of galvanising corrugated sheets is not difficult. After the iron sheets have been cleaned by a weak acid and wire brushes they are heated in a furnace and plunged into a bath of molten zinc. Here the surface of the iron sheets becomes alloyed with the zinc, and this coating protects the iron sheets from the action of the air or sea water.

Zinc is obtained from sulphide ores in various forms known as zinc blende or black jack. Frequently zinc is found associated with galena (lead sulphide), pyrites and copper. Whatever the original state of the zinc in the ore, it is necessary to get it to the form of an oxide before metallic zinc can be obtained.

If metallic zinc is required, the condensation must be done at a temperature higher than the fusion point of metallic zinc, otherwise the zinc will be collected in the state of zinc fume or zinc dust.

Although this dust is of use for certain purposes such as paint pigments, it cannot be remelted and turned into spelter.

Lead, iron and cadmium are impurities which have a bad effect on zinc, and therefore specifications frequently call for a zinc where the maximum amount of iron, lead and cadmium combined is less than 1 per cent. Although a little iron hardens spelter, it makes it brittle. Lead in small quantities makes

the spelter softer and easier to roll, but weakens the zinc so far as it effects a coating when used for galvanising steel roof sheets. Cadmium makes zinc brittle and is therefore a nuisance in the galvanising process because the coating cracks and falls off. Zinc in the form of castings weighs about 450 lb. a cubic foot, and in the form of sheet weight about 430 lb. a cubic foot.

NICKEL AND CHROMIUM

Although extremely important in the making of alloy steels for engineering, the average builder does not come into contact much with nickel as such. It is a metal which approaches silver in colour. It is principally used for nickel plating and for the making of German silver. It alloys very well both with copper and steel and adds great strength. The well-known Monel-metal is about $\frac{2}{3}$ nickel and nearly $\frac{1}{3}$ copper. It also contains a little iron and a little manganese. It resists corrosion very well, and has a high tensile strength when made into castings.

Chromium as a metal was discovered about a century and a half ago. Chromium plating is known to everybody. It looks well, is hard (a good deal harder in fact than steel), does not corrode or discolour. The French chemist who first isolated it as a metal called it chromium after the Greek word *chroma*, meaning colour.

An alloy steel containing 12 to 14 per cent of chromium and about 8 per cent of nickel does not tarnish, rust or stain. This alloy steel is today used for saucepans, scientific instruments, artificial legs, motor-car fittings, pressed sinks, bacon slicers, gardening tools, chairs, fireside fittings, valves and taps. In the heavy engineering field, chrome-steel is used for making the huge rollers which crush mineral ores. Chrome-steel, because it is rust-resisting and heat-resisting is used in chambers where the dust from very hot gases is collected.

QUESTIONS ON CHAPTER XI

How long has lead been used?

Is lead found (like coal) in a usable state?

What does the builder use lead for?

What is solder?

How much does a cubic foot of lead weigh?

Is chromium a recent discovery?

Is lead a good conductor of heat?

What is Monel-metal?

CHAPTER XII

TIN, ALUMINIUM, TUNGSTEN

Tin, Properties of—Tin-Foil—Malleability—Cry of Tin—Reverberatory Furnace—Pickling Sheets before Tinning—Aluminium—Symbols for Various Metals.

TIN

THE thin, shiny wrappings around cheese, chocolates, tobacco, etc., are often made of tin-foil, even if these are known as silver paper. Most of the tin cans in which fruits, vegetables, soups and milk are packed are not all tin, but a tin coating on a thin iron plate. More than 4,000,000 tons of tin plate is produced and used in a year ; this does not mean 4,000,000 tons of tin, but 4,000,000 tons of material actually coated with tin.

In addition to its use as a coating or plating for making containers for foodstuffs tin is very largely used for rolling into sheets for the covering of roofs and when mixed with other materials, is used in solders, white metal-bearing alloys, type metal for printers, pewter work and bronzes.

The chief sources of tin are the Federated Malay States, Bolivia, and Nigeria. In addition tin has been found in Australia, Russia, Mexico and Cornwall.

Tin is one of the whitest of metals—in fact, it is nearly as white as silver, but has a yellowish tinge, and is capable of taking a high polish. It has the characteristic of a crackling musical sound when bent—this is known as the “cry” of the metal, and there may be some analogy here when one refers to a singer’s voice as being “tinny.”

A MALLEABLE METAL

Tin is very malleable and ductile. It can be rolled into very thin sheets (remember the tin foil around chocolates or cheeses). It can be drawn into wire (but not easily and not as fine as copper wire). It melts at about 230 deg. C., and alloys very well with nearly all the common metals, but particularly well with lead. Tin resists corrosion satisfactorily either by air or water and is not dissolved by organic acids.

Tin ores contain many impurities and require a good deal of concentrating

before they can be smelted. After being crushed and washed the ores are roasted in order to convert the sulphides into sulphates. A sulphate is soluble in water, and by means of leaching or washing the oxides are separated from the heavy tin oxide by gravity. The product thus obtained is a more concentrated form than it was when originally found, and is known as a concentrate, generally as "black tin."

In Cornwall, the famous tin deposits have been worked for thousands of years. They were visited by the Phœnicians. In this country tin is reduced in reverberatory furnaces. Black tin, anthracite and fluxing agents are used. The tin, being heavier than the slag, collects under the slag as the charge becomes melted inside the furnace. The molten bath of metal is well stirred, and finally molten tin is tapped out of the furnace. The furnace in most essentials is very like the copper refining furnace, as will be seen by referring to *Plate 12*.

TIN PLATING

When a piece of iron or steel is reduced to a very thin sheet by passing it through rollers the steel becomes hard. In order to soften the sheets again, they are annealed by heating them in a special furnace and then dipping them in a very weak sulphuric or hydrochloric acid solution; this is known as "pickling" the sheets, and is done for the purpose of removing the scale. In order to remove the acid from the sheets, they are washed in lime water and are then ready for plating with tin.

A deep bath of molten tin is prepared and the thin, clean, iron sheet is pushed into this bath of molten tin through a box which contains zinc chloride. This zinc chloride cleans the surface of the iron before it enters into the molten tin. The sheet is completely immersed into the bath, and then, by means of special tools, is lifted until it is gripped by a pair of rollers, which revolve so as to lift the sheet upwards out of the bath of molten tin. There are three or four pairs of these rollers, one arranged above the other so that the lower rollers draw the tin to the next set; the next set lift it still higher until the top set of rollers is reached. The rollers run in molten grease; this ensures that the coating is of equal thickness (see sketch on *Plate 12*).

In a journal published by the International Tin Research and Development Council, I came across an interesting account of how veal which had been tinned for 127 years was still in perfect condition when it was opened in 1938.

The meat was originally canned in 1811 by a firm near London, and was one of many thousands taken out as a food store on the third voyage in search of the North-West Passage. For some reason or other, this particular tin of

meat was not used, but was brought back, and was included among the food stores in the next voyage, which began in 1826. Once again it was not used and the tin, which contained roast veal, found its way into a museum in Whitehall.

For years it lay unhonoured and unsung, until finally permission was granted to open the tin in 1938 in the presence of many chemical and medical experts. Examination of the contents was made on April 13th, 1938. The meat, says the report, was found to be in perfect condition, the appearance being like recently cooked veal. Tests carried out on the meat showed that it was of good quality originally, and that it had retained for over a century its nourishing properties to a high degree. Tin openers were unknown in those days, and this accounts for the wording on the label, which said, "Cut round the top with a hammer and chisel."

Aluminium, in a chemical form, constitutes a large part of the earth's crust but it is only during the last 70 years or so that the chemical production of metallic aluminium has been of real importance. The chief source of aluminium is bauxite which contains alumina, ferric oxide, silica, calcium, and manganese. Alumina is used in the making of Portland cement and for brick making, particularly some forms of fire brick. Aluminium is also obtained from eryolite.

LIGHT IN WEIGHT

Aluminium is a relatively soft metal which can be made to take a high polish, and it is a silvery-white in appearance. One of its main valuable properties is its lightness, and it is for this reason that it has been alloyed with other materials, particularly in the aircraft industry, where weight is of the utmost importance. Aluminium can be made into aluminium castings, and in this form is quite strong. It can be drawn into wire. It flows very easily under pressure, and is both malleable and ductile. Like tin and copper, aluminium can be rolled into very fine sheets. As an electrical conductor, it is fairly good. If the electrical conductivity of silver can be taken as 100, aluminium is about 58.

Although aluminium will resist cold, weak sulphuric acid it will not resist sulphuric acid in a concentrated form or hot. Aluminium is, however, unattacked by water, even boiling water, and for this reason it is very much used in the kitchen because it is good in appearance, and very light, and does not rust.

Aluminium alloys very well with zinc, copper, silica, nickel, tin and chromium. Aluminium zinc is largely used for castings, but, unfortunately, it is a somewhat brittle alloy. Duralumin is an alloy which has been largely

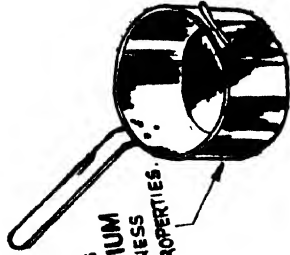

MANY KITCHEN UTENSILS ARE MADE OF ALUMINIUM BECAUSE OF ITS LIGHTNESS AND RUST RESISTING PROPERTIES.

MANY OF THE FITTINGS IN AEROPLANES ARE NOWADAYS MADE OF ALLOYS CONTAINING ALUMINIUM BECAUSE OF THEIR LIGHTNESS AND STRENGTH.



-NON-FERROUS METALS-
TIN, ALUMINIUM
TUNGSTEN, ETC.

ALL KINDS OF VEGETABLES, MEAT, FISH, POULTRY, AND FRUIT ARE NOWADAYS PRESERVED BY PLACING IN AIR-TIGHT STEEL CANS, COATED WITH A THIN FILM OF TIN.

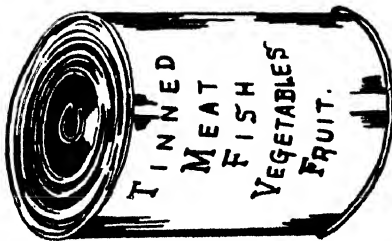

SOME KINDS OF PEWTER CONTAIN A SMALL AMOUNT OF COPPER.

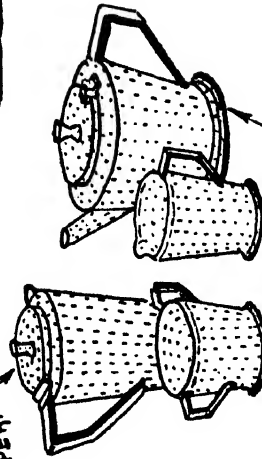

PEWTER TABLE WARE IS MADE FROM AN ALLOY WHICH CONSISTS OF ABOUT 80% TIN AND ABOUT 20% LEAD

GOOD QUALITY ELECTRIC LIGHT BULBS HAVE COVERED FILAMENT COATED WITH TUNGSTEN TO ENSURE THE FILAMENT LIFE FOR THE FILAMENT.

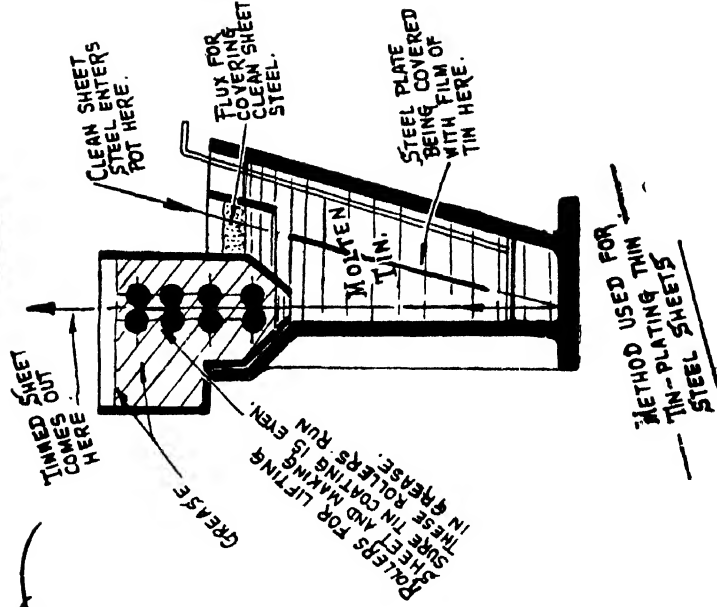
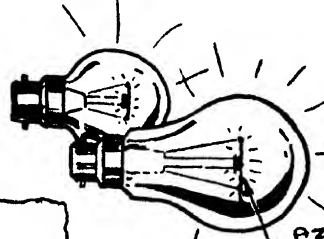

used in aeroplane and motor-car work because of its lightness and strength. Roughly the analysis of this material is :

Copper	4 per cent
Manganese	less than 1 per cent
Magnesium	” ” ” ”
Aluminium	the remainder

Aluminium-steel is extremely strong, and in the U.S.A. bridges have been built of this material because of the saving in weight.

Aluminium will not alloy with lead. It cannot satisfactorily be soldered.

Some metals have been known and used by man for many thousands of years, others have been discovered only in recent times. Because of this, some of the older metals have chemical symbols which come from the ancient Greek or ancient Roman names, while some of the more recently discovered metals have chemical symbols which are the first two letters of the metal.

Tin was known to the Romans nearly 20 centuries ago as *Stannus*, and for this reason the chemical symbol for tin is “Sn.” Aluminium as a metal has been known only about 100 years and its chemical symbol is “Al.” The various symbols which are used for the metals most commonly met with are given below :

<i>Material</i>								<i>Symbol</i>
Iron	Fe.
Copper	Cu.
Tin	Sn.
Lead	Pb.
Zinc	Zn.
Aluminium	Al.
Nickel	Ni.
Silver	Ag.
Chromium	Cr.
Manganese	Mn.
Gold	Au.

Molybdenum has been known for 150 years or so, but it is only during the present century that it has been largely used in the manufacture of steel. It is light grey in colour, hard and brittle, and has a high melting point. It is, of course, due to this latter quality that it is alloyed with iron manganese, or nickel, and is largely employed in the making of special tool steels. It has been

used also in the manufacture of armour-piercing shells and heavy guns. It has a much higher tensile strength than ordinary mild steel.

Tungsten is a hard metal which, when alloyed with steel, makes it highly resistant to shock. In very fine threads it is used for electric lamp filaments and can replace metals of the platinum type. It is about three times as hard as platinum. Tungsten has an electrical resistance of about two-thirds that of platinum, and its melting point is about twice as high. Although tungsten is expensive when compared with the ordinary metals, it is cheap when compared with the cost of platinum.

Tantalum is insoluble in all acids excepting sulphuric acid, and even sulphuric acid attacks it very slowly. It is a very hard metal, hard enough, in fact, to scratch quartz. It is very ductile and has high tensile strength. It is largely used for the preparation of metallic filaments for electric lamps, and when alloyed with iron makes a very tough material suitable for making into cutting tools, files and drills.

QUESTIONS ON CHAPTER XII

Is tin ductile and malleable?

Where is tin found?

What is the "cry" of tin?

Why are iron sheets "pickled" before tinning?

How long has alumina been used?

What is aluminium used for?

What are the symbols for iron, copper, tin, lead, silver?

Was tin known to the Romans?

What is tungsten used for?

CHAPTER XIII

CEMENT MAKING AND CONCRETE

Cement making—Wet Process—Kiln—Gypsum—Kinds of Cement—Ordinary Portland Cement—Rapid Hardening Portland Cement—High Alumina Cement.

CEMENT MAKING AND CONCRETE

Now we come to the manufacture of cement. Concrete is made of a mixture of cement, sand, aggregate and water. Aggregate is made of crushed stones, pebbles or ballast.

Although the Romans and even the Egyptians knew how to make joints between stone slabs by using mortar made from lime or burnt gypsum, it was not until 1827 that Aspdin produced what is now known as Portland cement. The name Portland Cement was given to it by Aspdin because concrete made from it resembled the well-known Portland stone. The materials from which cement is made are chalk, clay or marl, limestone and gypsum. These materials are to be found in many parts of the world and during the present century the manufacture of cement has increased tremendously. In fact, concrete and reinforced concrete can really be considered as a product of the twentieth century.

WET PROCESS

We show (*Plate 13*) the various processes through which the raw materials must pass in the preparation of cement by the wet process. The chalk or clay is taken out of a quarry by means of a steam or electric shovel, and then crushed in rolls of jaw crushers. Thence it passes to a washing mill. It will be realised that it is very important to have the correct amount of lime and water in the mixture, and before the crushed clay or chalk goes into the washing mill the correct proportions of clay, chalk and water are adjusted. This washing mill is really a tank. In the tank are arms which slowly rotate by means of a centre shaft. Each of these arms has some vertical projections which look rather like rakes or teeth. The flints and stones settle to the bottom of the tank as well as any heavy sand.

At the outlet of this wash tank screens are provided to catch any stones or flints which have not settled. The product from the wash-tank is a slime which

in the trade is known as a slurry. An analysis of the slurry is taken from time to time, and if it is not correct it is finally corrected in a dosage tank. From here the slurry is pumped or run to other tanks for storing and correcting. These storing tanks have moving arms or stirrers so that the slurry is kept well stirred up. By means of pumps the slurry is drawn off from these storage-agitating tanks and forced to the kilns. Where convenient the kilns are located fairly close to the tanks, but in some cases the slurry is pumped quite a long distance ; in fact, in one plant in South America the kilns are located more than five miles from the storage tanks.

The kiln is a long hollow tube made of steel plates riveted together. To protect the steel from the heat inside (which is generally about 2,300 deg. F.) a fire-brick lining is required. The kiln revolves slowly and its duty is to calcine or burn the slurry (which enters at the upper end) into a clinker. These kilns are sometimes 100 yards long and as much as 10 feet in diameter.

At the lower end of the kiln heat is provided by feeding in finely ground or pulverised coal through a burner.

The heat inside the rotating kiln is intense and the wet slurry which comes in at one end is burnt and comes out at the other end of the kiln as hot clinker. This clinker contains many lumps. To the lower end of the rotating kiln a rotating cylinder, of much smaller diameter than the kiln, is provided for the purpose of cooling the clinker. It must be cooled before it can be handled in the special grinding machines which reduce the clinker from lumps down to a powder almost as fine as flour.

This cooler is a double cylinder, one inside the other. The hot clinker as it moves down the cylinder is met by a cool current of air which cools it. The heat which is taken out of the hot clinker warms up this air which then passes into the rotating drying kiln.

The crushing of clinker is sometimes done in a tube-mill, which is a cylindrical tube suitably lined and containing rods which rise as the tube rotates and, by the cascading or falling action, crushes the clinkers. Inside the drum are a number of hard steel balls. As the drum rotates it carries these balls around until they fall on to the knobs, or, as they are generally called, the nodules, of cement, and this grinding pulverising is continued until the cement is small enough to pass through the perforations in the plates.

Crushed gypsum is added to the clinker which comes from the cooler before the grinding in the tube mills or ball mills is done. The purpose of adding this small quantity of gypsum is to retard the setting time, when concrete is being made. This gives more time for placing and ramming the concrete into position. The finished cement is now stored in large bins known as silos, and from thence to the bagging plant.

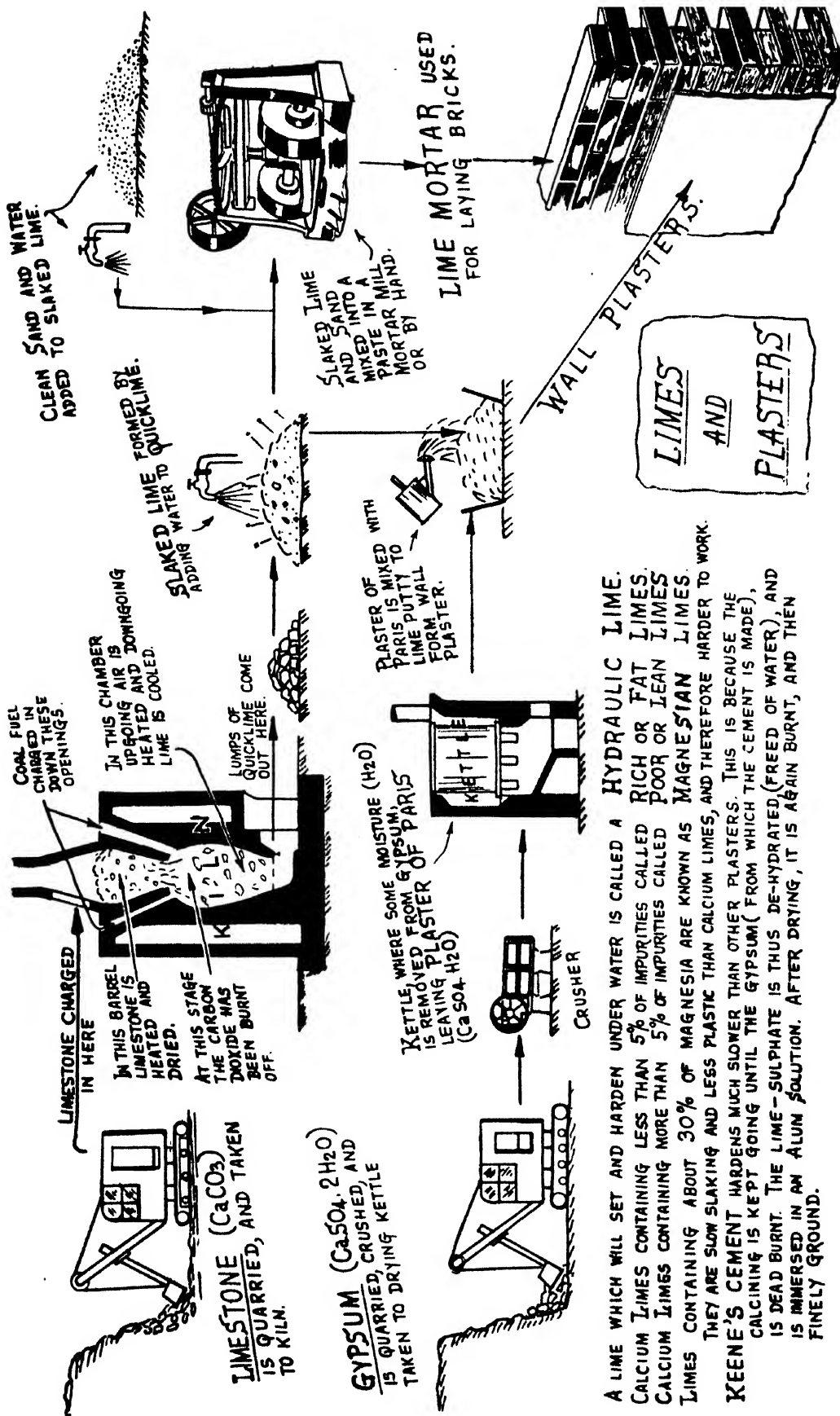

A LIME WHICH WILL SET AND HARDEN UNDER WATER IS CALLED A **HYDRAULIC LIME**. CALCIUM LIMES CONTAINING LESS THAN 5% OF IMPURITIES CALLED **POOR OR LEAN LIMES**. CALCIUM LIMES CONTAINING MORE THAN 5% OF IMPURITIES CALLED **MAGNESIAN LIMES**. LIMES CONTAINING ABOUT 30% OF MAGNESIA ARE KNOWN AS **MAGNESIAN LIMES**. THEY ARE SLOW SLAKING AND LESS PLASTIC THAN CALCIUM LIMES, AND THEREFORE HARDER TO WORK. **KEENE'S CEMENT** HARDENS MUCH SLOWER THAN OTHER PLASTERS. THIS IS BECAUSE THE CALCINING IS KEPT GOING UNTIL THE GYPSUM (FROM WHICH THE CEMENT IS MADE), IS DEAD BURNT. THE LIME-SULPHATE IS THUS DE-HYDRATED (FREED OF WATER), AND IS IMMERSSED IN AN ALUM SOLUTION. AFTER DRYING, IT IS AGAIN BURNT, AND THEN FINELY GROUND.

Cements are divided according to their setting or hardening qualities. There are three main kinds : (a) ordinary Portland cement ; (b) rapid hardening Portland cement ; (c) high alumina cement.

MATURING OF CONCRETE

Ordinary concrete made with normal hardening Portland cement will probably develop about 35 per cent of its ultimate strength after seven days. About $\frac{2}{3}$ of its maximum strength will have been developed 28 days after mixing and placing. The concrete will continue to increase in strength for many weeks after that ; probably 90 per cent of its maximum strength will have been reached after the concrete has been in position for three months.

It naturally follows that if the strength of the concrete has not been developed, the forms which are used for making columns and beams cannot be removed, as the concrete would collapse under its load. It is for this reason that forms are kept in position from seven to fourteen days after the concrete has been poured.

This, of course, slows down construction, and to overcome this drawback *Rapid Hardening Portland cement* has been developed. The main difference between this rapid hardening cement and the ordinary cement is not a chemical one, but a more fine grinding. With this class of cement 50 per cent of the maximum strength of an ordinary concrete would be developed three days after the concrete has been placed. It follows that the formwork or shuttering need remain in position only about half the time required when ordinary Portland cement is used.

HIGH ALUMINA CEMENT

Tests.—Tests are made for :

- (a) Fineness.
- (b) Chemical composition.
- (c) Compressive strength.
- (d) Setting time.
- (e) Soundness.

Fineness.—(1) The residue of a 170×170 mesh sieve shall not exceed 12 per cent.

(2) The residue on a 72×72 mesh sieve shall not exceed 1 per cent.

No rubbing should be done, but lumps may be broken down with the fingers. Sieves to be made from woven wire-cloth.

Chemical Composition.—The total alumina content will be between 36 per

cent and 39 per cent of the whole. The percentage of lime (CaO) will usually be about 38 per cent of the whole. The percentage of alumina to lime should not be less than 0.9 and not more than 1.3.

Strength (Cement Mortar).—Use one part by weight of cement, three parts by weight of sand, gauged with clean fresh water. Testing-sand is white sand which has been thoroughly washed and dried. The cement and standard sand must be thoroughly mixed before the water is added, and then thoroughly gauged on a non-absorbent surface with 8 per cent of water by weight of the dry materials. The tests should show a tensile strength of 600 lb. per sq. in. after three days, and about 650 lb. per sq. in. after seven days. The compressive strength of sand and cement cubes 24 hours after gauging must not be less than 5,000 lb. per sq. in., three days after gauging, not less than 6,000 lb. per sq. in. Concrete blocks made of this aluminous cement, sand, and aggregate, will probably show a compressive strength of 6,000 lb. per sq. in. 24 hours after gauging.

Tests for Setting Time.—The initial and final setting times is determined by means of the Vicat needle apparatus. Neat cement gauged with 22 per cent by weight of water should show initial set in not less than 30 minutes nor more than 4 hours. (Usually it is between 2 and 4 hours.) The final set should be not more than 2 hours after the initial set.

Soundness.—The cement can be tested for soundness by the “Le Chatelier” method.

PORTLAND CEMENT

The main essential elements in the raw materials used for Portland cement are lime, silica and alumina. Lime is found in materials such as limestone, chalk and marl. Silica and alumina, the first as quartz or flint, and the second as corundum or emery, are unsuitable for cement because of their extreme hardness, but silica and alumina as clay or shale are used extensively for cement. The approximate proportions for cement are 75 per cent calcium carbonate, and the remainder silica and alumina.

The raw materials are classified as (1) calcareous, in which the lime predominates; and (2) argillaceous.

Calcareous

Limestone.

Marl.

Chalk.

Marine shells.

Argillaceous.

Clay.

Shale.

Slate.

Blast furnace slag.

In England chalk is extensively used, 75 per cent of the cement being made from it in combination with clay.

Blast furnace slag is an artificial material produced as a by-product of the smelting of iron ores, with limestone as the fluxing material.

QUESTIONS ON CHAPTER XIII

How is cement made ?

What is the kiln for ?

Name three kinds of cement.

CHAPTER XIV

PLASTIC, WOODWOOL, FIBREGLASS

*Light Weight Concrete—Woodwool—Glasswool—Plastics—Terra Cotta—
Slag Wool—Stoneware.*

HARDBOARDS, FIBREBOARDS

HARDBOARDS of first quality have a good tensile strength and can be used to support about the same amount of weight as softwood of a similar thickness and span. The range of quality is rather wide and the thickness is generally something between $\frac{1}{8}$ in. and $\frac{3}{8}$ in. These hardboards are made of wood fibre consolidated under pressure. Often it is the by-product of the wood pulp used in paper making. The second quality product has very little tensile strength and damp quickly disintegrates it. By special process, good hardboard can be made which has a considerable resistance to moisture penetration. Hardboards can be sawn, planed, and nails can be driven through without causing splitting.

PLYWOOD

Enormous developments have been made in plywood production since 1920. Plywood is certain to be largely used in house construction in future years. Some of its advantages are lightness, resistance to corrosion and fairly good insulation. It is easy to handle and is assured of a place for thin walls and partitions. The plies are resin bonded or glued together and tests have shown that water or dampness does not separate the plies. Steel, copper and lead have been bonded to plywood and there is no trouble due to temperature contraction and expansion, as the adhesives used have elastic properties.

ASBESTOS WOOD

This material can be drilled, sawn and planed. Composed of asbestos fibre and cement there are a number of makes which are in common use.

ASBESTOS CEMENT SHEETS

As the name indicates, these are made from asbestos and Portland cement. When freshly made, the sheets are quite damp and as the cement has not yet

hardened completely, the sheets are easy to cut and are not very brittle. If kept for a good while in a dry storeroom, the sheets harden as the moisture dries out and they become brittle and certainly harder to cut. If they are of good quality, asbestos cement sheets are very durable but some of the inferior stuff which has come on the market from time to time easily crumbles. Most common faults to look for in flat asbestos sheets are waney edges, air cracks and variable thickness of the sheet.

WOODWOOL : CEMENT

The name is misleading, for it is nothing like wool and is not furry at all. It is really "shavings" which for building purposes may be $\frac{1}{8}$ in. wide \times $\frac{1}{100}$ in. thick. Woodwool when mixed with cement, silicate of soda and water can be made into wall slabs or panels. The material has good heat insulation properties and resists fire quite well. Sometimes the slabs are made under mechanical pressure. The size and the properties of the woodwool is quite important where the slabs are made in moulds without mechanical pressure being applied. In this latter case the slurry is forked into a mould, and as the cement sets, the panel is formed. Asbestos sheets about $\frac{3}{16}$ in. thick can be fixed both inside and outside of these wall slabs. It is important to notice that where the slabs are made without pressure being applied, there are several factors which determine whether the woodwool is satisfactory or not. The material should neither be dusty nor contain dry rot.

Woodwool cement has been in use for many years, but trouble has always been experienced, mainly with the non-setting of the cement, due to injurious substances in the wood. It was recognised early in their production that hardwoods were unsuitable for this purpose, but little is really known about the causes of failure.

Wood consists of cells, having walls of cellulose, which are cemented together with lignin. The interior of the cells contains water in which starches and sugars are dissolved. Also scattered throughout the structure are ducts which contain resins, fats, waxes and tannins. About half the weight of the dry timber is cellulose.

When cement is mixed with water an alkaline solution is produced which dissolves the lignin. It is not known that lignin has any deleterious effect on the setting of cement, but tannin certainly has.

The inclusion of bark raises the tannin content of any wood whilst knots increase the quantity of resin present.

Another detrimental effect of resins, gums and waxes in timbers is that of coating the surface of the woodwool strands so that the cement is not keyed to

the woodwool. This causes the cement slurry to run off the strands before it sets, and where it does not do this the adhesion is very easily broken by jarring of the finished product.

The surface coatings are often removed by dipping the woodwool before use in a solution of silicate of soda. This dissolves the resins and gums and so produces a clean surface.

Turning now to physical causes of the difficulties occurring during production, these fall mainly under two headings :

- (a) Size of the woodwool.
- (b) Moisture content of woodwool.

The moisture content of the woodwool is important.

MASTIC

This is really a material of a putty-like nature. It should be capable of sticking to two different materials such as concrete and steel. Putty is not suitable for filling in the space between concrete walls or concrete panels and steel window frames because it hardens on exposure. The mastic to be suitable must remain plastic (like plasticine). Various compositions using rubber and resin are used with varying success. Cement mortar is often used between the frame and the wall, but it is not really very suitable as the cement shrinks when it dries and leaves cracks through which damp penetrates.

ARTIFICIAL STONES

These are usually made of crushed granite or other natural stone, mixed with Portland cement. To fill up the voids, the blocks or slabs are soaked in silicate of soda. (This is water-glass, the stuff used for preserving eggs.) This forms a hard glass-like surface. Silicate of soda, or sodium silicate, is often used to coat the inside of concrete tanks used for storing liquids.

CEMENT BLOCKS

These are used for garages, farm buildings and sheds. They are made of Portland cement, sand and crushed stones. Natural cements are not so strong as Portland cement. Usually the proportions are about 1 of cement to 6 of aggregate. If the blocks are made with this mix and with a mortar made of 1 of Portland cement to 2 of sand, a good-looking and waterproof surface will be obtained.

PLASTICS

There are a great number of plastics, many varieties and many uses. The one thing common to all is that at some stage in the process of manufacture the material is *plastic*. It may be liquid, but this is not essential. What do we mean by plastic? Almost the opposite to elastic. When a child plays with plasticine it retains the shape into which it is pulled, bent, squeezed. It does not spring back like elastic or rubber. In some form or other plastic material is used in almost every industry: in buildings, table tops, panel facings, door facings, cupboards, floors and partitions.

For partitions which do not carry loads from floors as does a brick partition, centre slabs made of wood pulp, waste wood, sawdust bonded with resin and formed under pressure, have been made and used. This type is called non-load carrying and this should be kept in mind. The loads can, of course, be carried by steel columns and the "plastic slabs" used as panels between. The panels are light, easy to erect and can be quickly placed. Coverings may be made with plywood, veneer on each side of the slab or plastic materials of the Bakelite type can be used. These are made in various shades so that the facing on one side in one room may be quite different in colour to the facing which covers the slab and is seen in another room. For actual building wall construction, bricks have still many advantages which no other materials possess: structural strength and a large number of joints, each of which can move to some extent. Plastics have a great many uses but it will be a long time before brick and concrete are displaced by plastics as the materials for walls. For many purposes plastics will be increasingly used by the builder and engineer.

FIBREGLASS OR GLASSWOOL

Glasswool is an insulating material which has been developed during the last ten years. The materials of which it is made are silica, soda and lime. These ingredients are fed to the furnace in powder form. The furnace is lined with special heat-resisting bricks and heated by producer gas. In this furnace the materials are melted into glass which flows freely out through openings in the bottom of the furnace case. Jets of steam are made to impinge against the molten streams of glass, and these break it up into thin fibres. The glass is now in very fine threads and in the form of a fluffy material and is collected into a large box. Bitumen solution is sprayed on to this fluffy material in order to bond it together. A wide flat conveyor collects this sprayed glass, which looks like a dark coloured blanket, 2 in. thick, as it travels along to the drying chambers. Here heat is applied and very much drier material passes on its way to the cooling chambers. Cooling is done by air. After passing through various

rolls, the blanket of fibreglass, glasswool as it is sometimes called, arrives at the end of the machine in a continual strip, which may be anything from 2 ft. to 4 ft. wide and about 1 in. thick. Fibreglass is taken off the machine in rolls, a leaf of paper having been inserted mechanically during the travel of the material along the conveyor. The material is particularly light, and a roll of 4 ft. wide and 3 ft. diameter can be quite easily handled by one man. Glasswool has very good insulating properties and can easily be cut to sizes by means of a sharp knife and a straight edge.

SLAGWOOL

Slagwool is an insulating material produced by heating slag in a cupola and breaking it up into a woolly form by passing jets of steam through the molten material. The binder is provided by spraying resin or bitumen into the thin fibrous material. The fibres are about 1/50th of an inch in diameter. In order to get uniform moisture content the blanket mat is passed through a steam chamber which ensures sufficient wetness. From this chamber the material travels on a flat conveyor to a drying chamber. The finished product is then sawn off to the required lengths. Most of these woodwool products are fairly easy to handle in small panels, but require some careful handling if the panels get large.

ALUMINIUM FOIL INSULATION

Thin sheet aluminium has been successfully used as an insulating medium. It depends for its insulating properties on reflection. It is formed of two thin sheets, one straight and the other in the form of half rounds of V's. The inner sheet is straight and the other sheet in plan is a series of triangles. As the heat strikes the inclined surfaces it is reflected back in much the same way as light beams are reflected. This type of insulation has been successfully used in the walls of temporary houses. The metal should be kept at least $\frac{1}{2}$ in. clear of the main framework.

STONEWARE

Stoneware is a material of the greatest importance in building operations. The substance can be defined as pottery-ware of the coarser class, baked hard and finally glazed to give it a protective covering.

Ordinary drain-pipes, sewer-pipes and general drainage fittings are made of glazed stoneware.

Glazed stoneware articles are not affected by chemical action, nor by a polluted atmosphere. In its unglazed state stoneware is practically non-absorbent, and resists dampness, but the glazing is done as an additional safeguard to ensure that the material shall be quite impervious to moisture, and

better able to resist the actions of the many destructive agents it is likely to come into contact with.

The essential properties of lias-clay for stoneware manufacture are (a) plasticity, or the quality of being easily worked when moist, into any desired shape, (b) the property of becoming perfectly hard, dense and durable when burnt in kilns at a suitable temperature.

The lias-clay in its natural state consists of about 76 per cent of silica and 24 per cent of alumina, together with traces of iron, calcium and other minor ingredients. The natural clay develops a tendency to excessive contraction or shrinkage during the firing process. This is counteracted by mixing in with the clay the other material, such as sand, powdered stoneware, or granite ground fine.

TERRA-COTTA

Terra-Cotta can have either a glazed or unglazed face, although the latter finish is seldom used for facing buildings nowadays.

The blocks should have true lines and be free from cracks, warps and twists. The face of the block has a more vitrified finish than the interior and for this reason care must be taken to avoid chipping or rubbing in fixing and transportation. Cutting should be avoided and every block should be to correct size to fit in its particular place. The blocks are numbered and fixed according to a key plan. It is usual to back terra-cotta with either brickwork or concrete and the block dimensions are some multiple of brick-size, but should not exceed 4 cubic feet.

Suitable clay is found in many districts, the constituents and mixing methods varying in different localities. A high silica and low alkali content in the clay gives it a refractory nature, but sufficient alkali should be present to provide the vitrified surface which gives the material durability.

The blocks must be well soaked before filling. The best filling materials are $\frac{3}{4}$ in. crushed ballast, clean sand and Portland cement in the proportion 1 : 7. An alternative filling is composed of 6 parts crushed brick and 1 part Portland cement. Neither of these fillings are liable to expansion and for this reason breeze should never be used.

The filling should be done before fixing.

The joints should be $\frac{1}{4}$ in. approximately and weathered to prevent spalling. A dove-tailed slot is often provided in the vertical joints and these should be filled with cement grout after fixing. Care must be taken to keep the surface clean and free from mortar stains.

Cramps and dowels should be of copper or galvanised iron.

Slabs in various sizes and about 1 in. in thickness are obtainable and are

used to provide a veneer to brickwork or concrete. The slabs are bedded to the surface of the stoneware with cement mortar 1 : 3 and tied back at regular intervals. Bonding courses should be provided on large areas.

PERSPEX

This is a new material which looks like glass. It is light in weight and can be planed, drilled and sawn. It is tough and does not easily break. Perspex is made in various colours, and has many uses. When made into corrugations of the same size as roofing sheets it can be used as roof glazing, or when not corrugated can be used as roof lights. Suitable for furniture and decorative work, it can be sprayed with cellulose covering. Since it is not very brittle it does not fracture and fly as glass does. Perspex will play quite a part in the materials which builders will use in the future, particularly when production reaches such limits as will reduce the price.

QUESTIONS ON CHAPTER XIV

What is fibreglass?

What is woodwool?

What is fibreboard?

What is hardboard?

CHAPTER XV

REINFORCED CONCRETE

Reinforced Concrete—Tensile Strength—Why is Concrete Reinforced?—Stresses used in Reinforced Concrete Design—Grip Strength—Arrangement of Bars—Types of Columns—Effect of Mix on Water-tightness of Concrete.

REINFORCED CONCRETE

WE know that the various materials which go to the making of concrete are stone, either in a natural form or in an artificial form, sand and cement ; also that the various proportions of these materials are measured by volume and not by weight. The proportions are known as the mix, and a 1-2-4 mix means that there is one part of cement by volume, two parts of fine aggregate, generally sand, by volume, and four parts of coarse aggregate, which may be in the form of pebbles, crushed stone or certain furnace slags ; these are also measured by volume. If a bag of cement holds 112 lb., the volume will be very near to one and a quarter cubic feet. In Chapters VIII and IX, dealing with lintols and bressummers, we showed that if an ordinary beam is supported at both ends, the lower side of the beam stretches, and the top side of the beam shortens when the beam bends.

TENSILE STRENGTH

The fundamental thing to keep in mind about concrete is that it is very strong in compression and very weak in tension. As a matter of fact, although concrete has certainly some strength in tension, it is quite in line with good design to neglect this tensile strength altogether, and to put in steel rods to take care of all the tensile stresses, in order to prevent the concrete cracking and breaking.

If we look at *Plate 14*, Fig. 1 shows a short column in which the length of the column is not more than eight times the least side. Such a column might be made of plain concrete and without any reinforcing steel bars, provided the load was directly over the column.

Now look at Figs. 6 and 7. In Fig. 6 the brick wall $13\frac{1}{2}$ in. thick has no footing and rests on concrete, which has no steel reinforcing bars. The weight on the floors of the buildings and the weight of the wall itself rest on this concrete footing. Obviously, if the ground was a sludge or very soft, the

whole wall could sink, but if it is chalk or clay the ground would resist the downward force which is trying to compress it, and because the ground has elastic properties, just as a piece of rubber, it is actually pushing upwards with the same force as the load is pushing downwards.

If the concrete is too thin, failure might take place by the concrete breaking as shown in Fig. 7. Notice that the foundation block has cracked open on the underside, so that the length from C to D is longer than the length from A to B. It is therefore clear that there is a tendency for the concrete on the underside of the footing to stretch, or, to use technical words, the concrete is in tension. To take care of these tensile stresses and to prevent the concrete breaking, steel bars can be put in the concrete as shown in Fig. 9. Sometimes expanded metal is put in instead of steel rods. This type of footing is quite safe, and the reason it is not more commonly used is that the cost of buying and placing the steel is often more than the cost of making a thicker concrete footing or, alternatively, of spreading the wall as shown in Fig. 8.

The difference between using a foundation like Fig. 8 and Fig. 9 is that in Fig. 8 the wall is spread so that there is very little bending moment on the concrete footing, whereas in Fig. 9 there is bending moment, but sufficient steel is put into the concrete to resist this moment, and to prevent the concrete breaking up as shown in Fig. 7.

Mild steel bars are very strong both in tension and compression. In order to break a steel bar which is 1 in. square by pulling it apart, we should probably have to pull with a force of about 32 tons. Naturally, in order to be safe, we allow a load which is very much less than this figure. Actually, about eight tons is considered safe for a 1 in. square bar. Technically, we say mild steel has a safe working stress of eight tons a square inch in tension.

Reinforced concrete design is made on the assumption that the concrete itself takes care of the compression and that sufficient steel should be put in to take care of the tensile of pulling stress. The right amount of steel and the correct position of the steel is, of course, a matter for the expert, and we cannot deal with it in this chapter. The table below gives the working stresses which are generally used in reinforced concrete design. By reinforced concrete we mean concrete which is strengthened by the introduction of steel.

	<i>lb. per sq. in.</i>
Concrete in compression in beams ..	600 to 800
Concrete in shear in beams	60 to 80
Grip strength of concrete to reinforcing bars	80 to 100
Steel bars in tension	16,000 to 18,000
Steel in shear	10,000 to 12,000

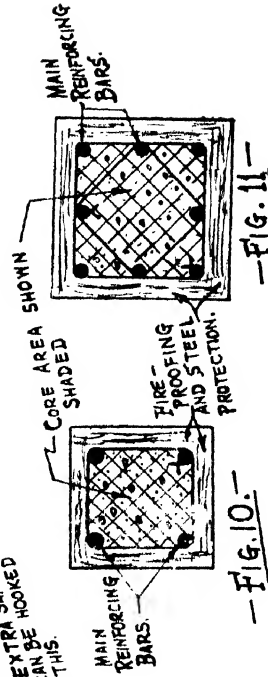
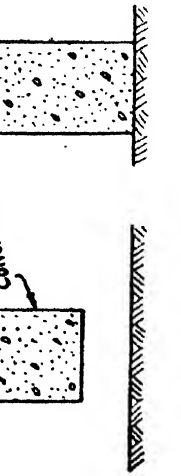
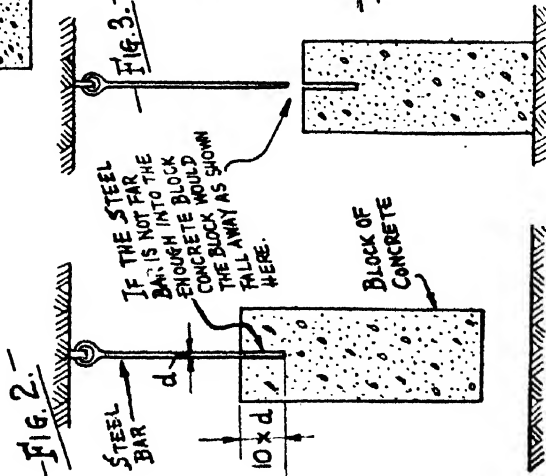
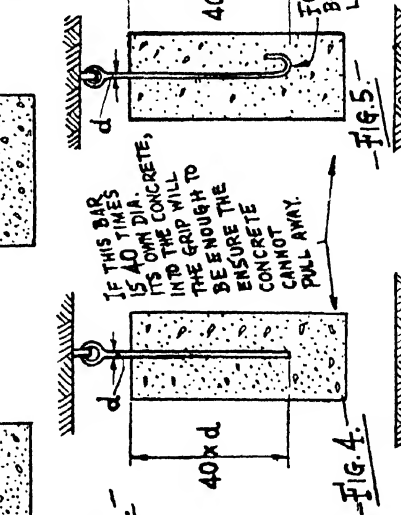
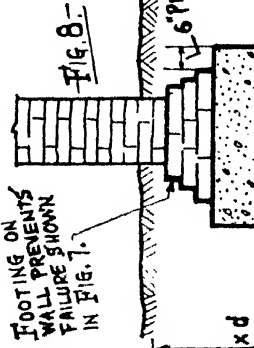
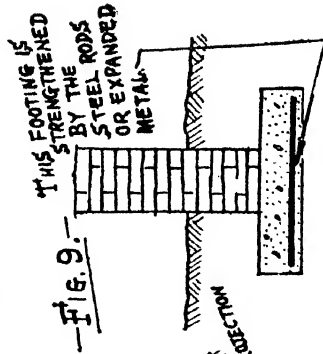
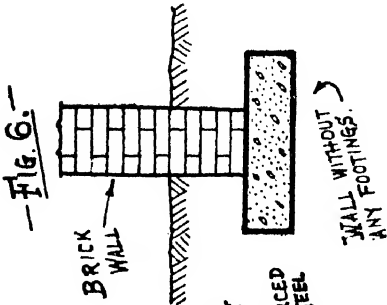
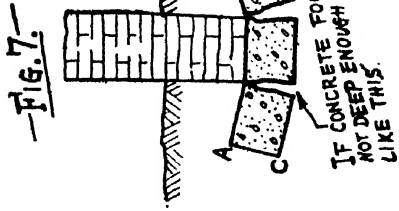
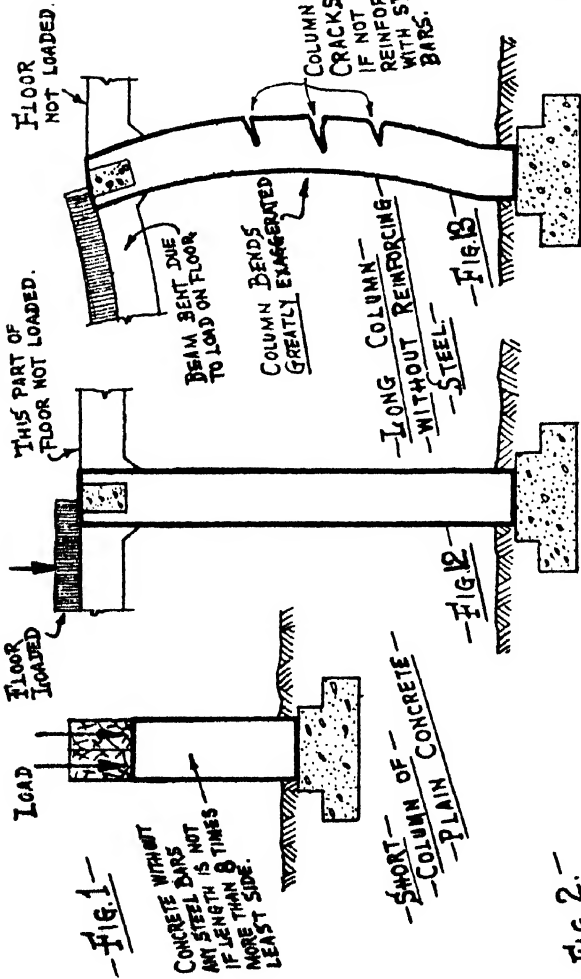

By looking at Figs. 12 and 13 in *Plate 14* we can see why it is necessary to put steel bars into long concrete columns such as we find in large buildings. On the different floors there will always be some part loaded and some part not and this causes the floor beams and the columns to bend. The amount of beam bending and column cracking are shown greatly exaggerated in Fig. 13, but it is in order to prevent these cracks in the beams and columns that steel bars are introduced.

CARRYING LOADS

The reinforced concrete building is quite a different type from the steel-frame building. In the former the concrete is used for carrying loads and is reinforced or strengthened by steel bars. In steel-frame construction, the steel columns and steel beams are designed strong enough to carry all the loads, and the concrete covering around the steel sections is for the purpose of fire protection and architectural effect.

A little thought will show that the strength of the reinforcing steel rods in concrete cannot be developed unless there is adhesion or grip between the concrete and the steel. Looking at Figs. 7 and 9 again, we can see that if the steel bars shown in Fig. 9 were very highly polished and greased with vaseline before the concrete was poured there would be little or no grip between the concrete and the steel. In such a case, the footing could break exactly as shown in Fig. 7 because the steel in the middle piece of the concrete could remain in position while the two outer pieces could slide up the greasy steel bars. To prevent this sort of thing from happening, reinforcing bars should not be polished or greasy. To increase grip strength still further there are many patent bars on the market which have special shapes or projections so that they cannot pull through the concrete.

Many experiments have been made to find just how much grip there is between an ordinary round mild steel bar and concrete. It has been found that it would take something between 300 lb. and 400 lb. per square inch of surface to pull a steel rod out of concrete when once the concrete is properly set. It is therefore considered generally safe to allow a bond stress or a grip stress up to 100 lb. a square inch.

In Fig. 2 it is easy to see that the surface area of the bar which is in contact with the concrete is the perimeter (distance round the bar) multiplied by its length. The perimeter in the case of a round bar is the circumference, which is 3.14 times the diameter of the rod, and in the case of the square bar, is the four sides added together. With a reinforced rod 1 in. square, buried 10 inches into the concrete, the surface in contact will be four sides each 10 inches long. This will make a total of 40 square inches of steel touching the concrete. If the

bar is 1 in. diameter and 10 inches into the concrete as before, the perimeter will be 3.14 inches, and the length 10 inches, so that in this case the area of contact is nearly $31\frac{1}{2}$ square inches.

PULLING OUT STEEL

As we stated previously, experiments have shown that in order to pull the steel out of the concrete a force of 400 lb. would have to be exerted on each square inch of surface in contact. With the 1 in. square bar buried 10 inches in concrete, the contact surface is 40 square inches, so that the force to pull the bar out would be something in the region of 40 by 400=16,000 lb., that is, very nearly $7\frac{1}{2}$ tons. In the case of the round bar, the contact area is 31.4 square inches, so that the force to pull this bar out would be something in the region of 31.4 by 400, say, 12,600 lb.

This point will be made quite clear if we consider the block of concrete in Fig. 2 as weighing $7\frac{1}{2}$ tons. If the steel bar from which the concrete is suspended is square, it will be touch and go whether the concrete block falls or not. If the bar is round, it is very probable that the block will rip off, as shown in Fig. 3. Naturally we do not take too many risks when designing buildings, so that generally the maximum adhesion or bond stress is taken at 100 lb. per square inch. (See *Plate 14.*)

In the example dealt with, the bars were buried only 10 times their diameter into the concrete, and it was a case of touch and go whether there was any slip or not. In order to make sure that there is no slip, the grip length is generally made something in the region of 40 times the bar diameter, as shown in Fig. 4. As an extra measure of safety, the ends of bars are often hooked over as shown in Figs. 5 and 14. The arrangement of steel bars in a concrete beam is shown in *Plate 9*, page 63, and it will be seen that the ends of the bars are bent over.

ARRANGEMENT OF BARS

Two typical arrangements of bars are shown in Figs. 10 and 11. The main reinforcing bars shown in black circles are the vertical bars, and are tied together and held in position by smaller bars or spaced at between 6 inches and 12 inches apart and should be not less than $\frac{1}{4}$ in. diameter. Where the columns are round, the vertical bars are sometimes held in position by these small bars wrapped around in the form of a spiral. (*Plate 14.*)

Until a few years ago it was assumed that the effective area of a column was the concrete inside the ties.

This was known as the core area, and is shown by the shaded lines on the

drawing. The area outside the lines was assumed to be fireproofing or steel protection, and was not taken into account in calculating the strength of the column. In recent years this has been altered, and now the safe load on a reinforced concrete column is calculated by assuming the total cross sectional area of the column as being effective in the case of square columns.

There are about eight principal kinds of columns used in buildings.

- (1) Plain concrete, sometimes used for short columns, has no steel reinforcing bars.
- (2) Concrete columns reinforced with vertical steel bars tied together with smaller bars at definite intervals.
- (3) Concrete columns reinforced with vertical steel bars held in position by a continuous steel spiral hoop.
- (4) Columns with a rolled steel joist in the centre, spiral hoop around the joist, and the whole encased in concrete.
- (5) Rolled steel sections covered with concrete for fire resistance. In this construction the strength of the steel column only is taken into account.
- (6) Rolled steel or built-up steel sections without any form of concrete protection.
- (7) Cast-iron pillars either hollow-round or hollow-square. This type of construction used to be very common on railway stations and in the textile mills in the north of England. With the increased tensile strength which modern research has made possible in cast-iron, and the shortage of steel these days, it is quite likely that cast-iron columns may be increasingly used in the near future.
- (8) Timber columns or posts.

In addition to being largely used on building construction, reinforced concrete is used for making bridges, grain storage silos, water tanks, machinery foundations, retaining walls, roads, chimney stacks, piles under foundations, piers, wharves.

WATERTIGHTNESS

An important point to keep in mind is that the ordinary mix of concrete is not completely watertight. If some waterproofing material is mixed in with the concrete, the compressive strength of the concrete will be reduced. A richer mix such as 1-1-2 can be damp-proof and waterproof. Although there will be more cement used per cubic yard of concrete placed, concrete made of a 1-1-2 mix is considerably stronger than concrete made with a 1-2-4 mix. Therefore the total amount of concrete required will be less for the rich mix than for the ordinary mix. A 1-1½-3 mix of concrete, although not absolutely damp-proof, can be considered watertight.

WORKING TEMPERATURE

In Britain, the temperature is seldom sufficiently high to cause any trouble with concreting, but in countries where high temperatures are reached, the stone in the aggregate should be very thoroughly wetted and the sand kept away from the direct sunshine. It will also be a wise precaution to have the concrete mixing machine roofed over to protect it from the sun's rays. Otherwise the heat will cause quicker setting of the cement and there is a tendency to produce lumpy concrete.

It is generally considered bad to do concreting work when the temperature is below freezing point. The setting is slowed up. Concrete work has been satisfactorily done when there have been one or two degrees of frost. In such cases salt is generally added to the water to prevent the concrete from freezing. More than 8 or 10 per cent of salt should never be used. One of the troubles of adding salt is that it causes the surface of the concrete to be covered with a white deposit known as efflorescence.

Although there is no difficulty in making joints in concrete which is not completely set, it is quite a difficult job to join new concrete on to old. Where it is necessary to do this the old concrete should be thoroughly hacked and chipped so as to expose a good clean surface. After thoroughly wetting a couple of coats of a rich cement mortar should be applied to the old work, and before these are set, fresh concrete can be placed. The strength of such a joint is always somewhat uncertain.

The following table gives the areas, weights and circumferences of round and square bars.

ROUND BARS

Diameter of bar Inches	Weight per foot lb.	Circumference of rod Inches	Area Square Inches
$\frac{1}{4}$.17	.78	.049
$\frac{5}{16}$.26	.98	.077
$\frac{3}{8}$.37	1.18	.11
$\frac{1}{2}$.67	1.57	.19
$\frac{5}{8}$	1.04	1.96	.31
$\frac{3}{4}$	1.50	2.35	.44
$\frac{7}{8}$	2.04	2.75	.60
1	2.67	3.14	.78
$1\frac{1}{8}$	3.38	3.53	.99
$1\frac{1}{4}$	4.17	3.92	1.22

SQUARE BARS

Side of bar Inches	Weight per foot lb.	Area Square Inches
$\frac{1}{4}$.21	.062
$\frac{5}{16}$.33	.097
$\frac{3}{8}$.47	.14
$\frac{1}{2}$.85	.25
$\frac{5}{8}$	1.32	.39
$\frac{3}{4}$	1.91	.56
$\frac{7}{8}$	2.60	.76
1	3.40	1.00
$1\frac{1}{8}$	4.30	1.26
$1\frac{1}{4}$	5.31	1.56

QUESTIONS ON CHAPTER XV

What is reinforced concrete?

What is concrete reinforced with?

Why is it necessary to reinforce concrete?

What is concrete made of?

What is grip strength?

Name four principal kinds of columns used in building construction.

What do you understand by "Concrete mix"?

Is concrete watertight?

CHAPTER XVI

LIMES AND PLASTERS

Limes and Plasters—Rich Limes—Mortars—Lime Mortar, Cement Mortar—Impurities in Limestone—Quicklime—Hydraulic Limes—Plaster of Paris—Keenes Cement.

LIMES AND PLASTERS

LIME is made from limestone. There are many varieties of limestone ; chalk for instance, is a fine grained limestone composed of very fine shells. The chalk may be a very pure material containing only 2 or 3 per cent of siliceous material in the form of siliceous alumina, or it may be a less white colour containing 10 or 15 per cent of clayey (argillaceous) material. This clay is really a fundamental part of the chalk and cannot be removed. If the chalk contains less than about 5 per cent of this clay stuff the lime produced is known as a " rich " or " fat " lime. These rich fat limes are easy to work. This sort of lime should not be used in positions where there is dampness. If chalk lime is used for mortar in outside brick walling it will not set and in time will crumble.

CHALK DEPOSITS

The chief deposits of chalk in England are in the Thames Estuary and on the Downs. Marble is really a limestone and as a matter of fact one of the purest of limestones. It is not used for lime-making, because it is so very hard that it would be a costly process to grind it up to the fineness required. Sometimes in laboratory work marble is actually ground up for making into lime.

The best limestone deposits in this country are in the Peak District of Derbyshire. Lime burning has long been an industry in this district, and some of the limestone is as pure as is found anywhere in the world. Derbyshire limestone is particularly good for making into plasters, as it contains the highest percentage of calcium carbonate.

Calcium carbonate (carbonate of lime), is really quicklime and carbon dioxide. In a pure calcium carbonate there would be 56 per cent of quicklime and 44 per cent of carbon dioxide.

No limestone exists in an absolutely pure state, but some of the best Derbyshire limestones contain more than 98 per cent of carbonate of lime. Impurities are silica, iron oxide, alumina and magnesia.

Magnesium limestones are not nearly so pure as the best Derbyshire limestones ; they contain anything up to 20 per cent of magnesium. Limes made from chalk or limestones, which contain very little magnesium, are known as calcium limes. These contain less than 1 per cent of magnesium.

If there is 10 per cent or more magnesium, slaking will take place much more slowly. Care is necessary to make sure that the quicklime has been thoroughly slaked.

A good limestone is composed very nearly entirely of calcium carbonate. It should be noted that this calcium carbonate is a mixture of quicklime and carbon dioxide. To get the quicklime, the carbon dioxide is burned off. By heating the limestone to a temperature of 800 deg. C. or more, the calcium carbonate is disassociated or broken up. Carbon dioxide is driven off as a gas while the white solid calcium oxide is left behind. This calcium oxide is generally known as caustic lime or quicklime, and is the main constituent of mortar which bricklayers and builders have used for more than 1,000 years. In recent years cement mortar has been largely used because it is stronger than lime mortar.

Lime burning is done in various forms of lime kiln, most of them vertical. Some of these are built entirely of brick, others are of a steel shell lined with firebrick. Sometimes a rotary kiln of the cement making type is used.

Mortar as used by builders for bricklaying consists of a lime paste. This is really a lime putty into which sand has been mixed. Slaked lime is a powder formed by adding water to quicklime.

If quicklime or caustic lime in lump form is placed in a vat or tub, water is poured on it, the mixture swells and generates considerable heat. Steam is driven off, there are a number of small explosions or poppings all the time as the lumps crack. If the amount of water added has been equal to about one-third of the quicklime, the lumps crack up and fall in a fine powder which is known as slaked lime.

By adding more water and stirring, a thick paste (lime putty) is formed. It will be found that the lime putty occupies considerably more space than did the original quicklime. From this lime putty mortar is made by mixing sand with the lime. Sand is considerably cheaper than lime, and as it increases the bulk, the cost of the mortar is less than the cost of pure lime.

During the process of slaking, the lime expands considerably, when setting the volume decreases, and for this reason it cannot be used for a mortar, as there would be shrinkage and cracking.

PREVENTION OF CRACKING

Where furnaces are lined with firebrick (silica or magnesite), the joints are generally kept as thin as possible. This is done to keep cracking down to a minimum.

The mixing of the lime and sand may be done by hand or by grinding or mixing in a form of machine known as a "Chilean mill" or pan grinder. This consists really of two heavy rollers working in a pan; these crush down the sand and mix very thoroughly the lime and sand together.

A sketch of such a machine is shown in *Plate 15*.

The sand used should be clean and sharp and gritty. It should be free from clay and salts; for this reason river sand from fresh water streams is best, and sea sands should not be used unless they have been well washed to free them from salt.

High calcium limes generally contain less than 5 per cent magnesium. Magnesium limes contain between 5 and 30 per cent of magnesia. A lime which contains 5 per cent or more of impurities in the form of silica, alumina iron oxide, or magnesia, will be generally dark in colour. They will take a long time to slake, and the bricklayer will find them more difficult to trowel. These are known as impure or lean limes.

When Smeaton was building the Eddystone Lighthouse, one of the difficulties he found was how to get a lime which would set under water. Ordinary lime mortar will not do this. After experiments he found that limes prepared from limestone which contains a fair amount of clay would set even under water. For this reason, limes which will set hard even under water are known as "hydraulic limes."

Limes containing less clay, but which will set hard under water after a long time are called "moderately hydraulic or semi-hydraulic limes."

HYDRAULIC LIMES

Blue-lias limestones are about the best hydraulic limes in England.

The lias formation is a clay-silica limestone, and was formed mainly from the organic remains of giant reptiles which infested the sea and land. Such limes slake very slowly, and swell but little. They rapidly set, even under water, but because they contain a considerable proportion of silica and alumina in the clay which is combined with the lime, a smaller amount of sand need be mixed with the lias limes than with the more pure limes.

Hydraulic limes should always be used for making lime concrete but should not be used for plaster work. Chalk lime should be used for internal plaster work.

Hydralime is not a hydraulic or water lime. It is carefully prepared, burnt, slaked, and despatched from the works in the form of a very fine powder. It therefore mixes more intimately with sand than lime, which is not so finely ground. It also hardens quicker and forms a stronger mortar. The fine grind-

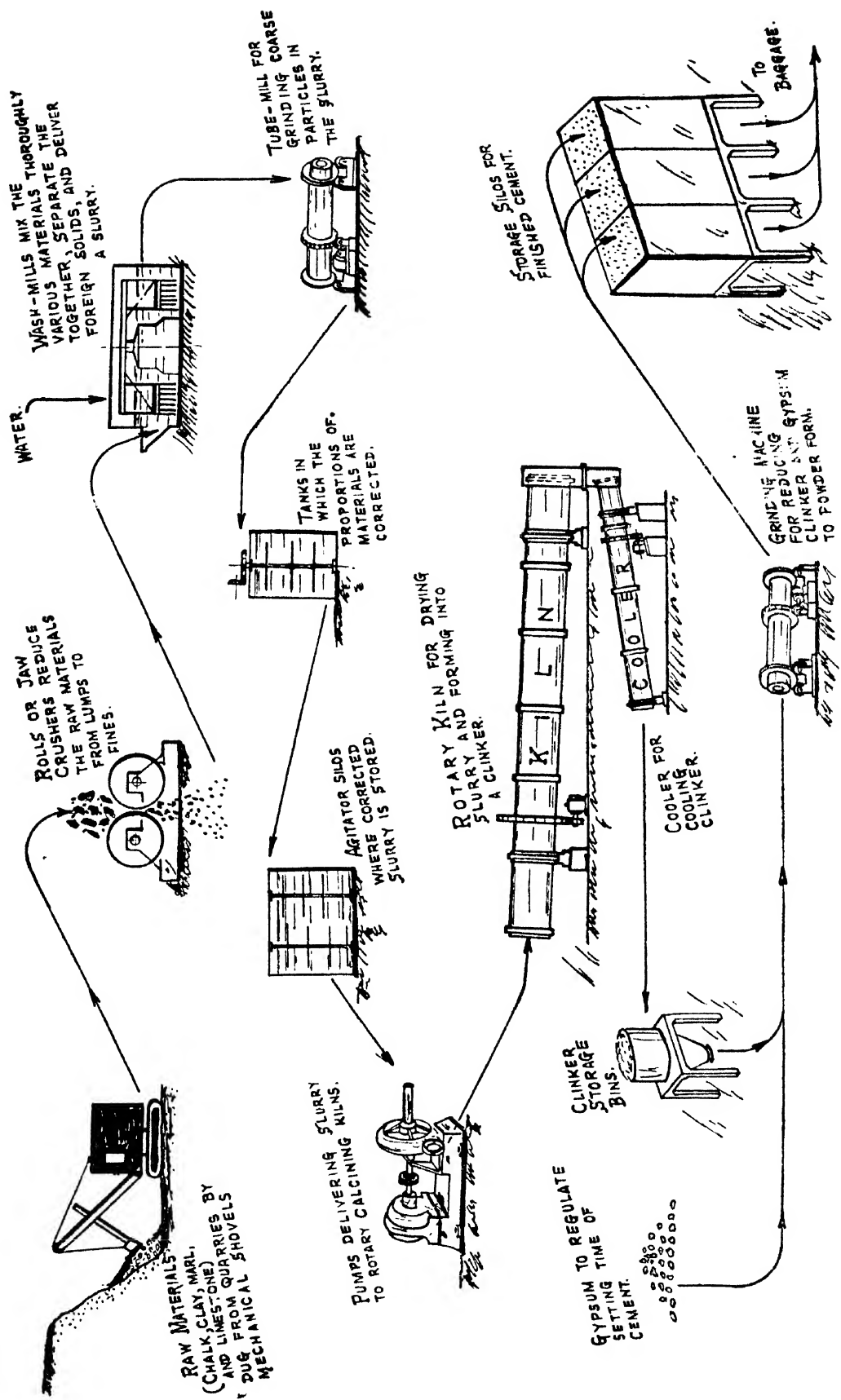

ing costs money, but in some cases the additional cost is justified, as hydralime stores better than lump lime. More sand can be used, thus making a greater bulk per unit cost of hydralime.

If a small amount of plaster of paris is added to limes which contain silica and alumina or to magnesium limes, selentic lime is formed and mortar made from it will set more quickly. It also allows a larger percentage of sand to be added to ordinary lime without loss of strength. It is thus a time-saver and at very little if any extra cost.

Lime mortar for setting bricks usually consists of one part of grey-stone lime and two parts of sand. In wet ground blue-lias lime should be used, as this sets under water. Chalk lime is not good as it is very soluble and does not set satisfactorily. It is important to see that the sand used is sharp, and free from dirt.

A good rendering coat for lathing is about two parts sand, one part lime, and something like eight or nine pounds of hair per cubic yard.

For a floating or second coat, three parts of sand, one part of lime, and four pounds of hair per cubic yard is a pretty good average mixture. The final coat will have plaster of paris added to the lime.

For plastering the inside of brick walls, the first coat might be of three parts of sand and one part of lime, and five pounds of hair per cubic yard of mixture. Because brickwork is porous the plaster will dry quicker on a dry wall than the first coat on wood laths. The various coats must be dry before the next coat is applied. This takes time.

The second coat on walls might be the same as the first, and the final coat might be one and a half parts of sand and one part of lime. Some builders add up to 20 per cent of plaster of paris.

Internal plaster work will blister if lime is not properly slaked.

Plaster of paris is made from gypsum, which is a hydrated sulphate of lime, found as a rock or stone. It is found in many parts of England, the Continent, and U.S.A. It is probably because of the large quantities existing around Paris that this product of gypsum has received its name. Gypsum is mined or quarried by blasting and removed by mechanical shovels or excavators.

A general idea of the process through which gypsum passes before it becomes plaster of paris is shown in *Plate 15*. After the gypsum is crushed, it is put into a lined vessel (known as a kettle) and heated by a coal fire. Some of the water in the gypsum is driven off, but the gypsum is not completely dry-burnt. Gypsum, as found, contains impurities such as silica, alumina, magnesium, but in a good gypsum-rock these impurities often amount to less than 5 per cent of the whole.

PLASTER OF PARIS

Plaster of paris has the property of readily recombining with water to form gypsum again. It hardens in a very few minutes, and one of its characteristics is that during this hardening process it shrinks and then expands. For this reason it is very useful for filling up holes.

The builder uses plaster of paris chiefly for making ornaments on ceilings, and for the plastering of walls. It is not used as a wall coating by itself, but is added to the finishing coat.

When squeezed in the hand, good pieces of plaster of paris will tend to stick together if the hand is gently opened. A plaster which has become dead by dampness will fall to bits immediately, and such a plaster is of very little use.

There are a number of plasters which set to a very hard surface. Keene's cement is probably the best known of any of them. In the making of ordinary plaster of paris, gypsum is not fully calcined or dead-burnt; in other words it is not completely freed from water. In the making of Keene's cement, the gypsum is completely dried. The result of this is that it hardens much more than ordinary plasters.

This hardening process can be somewhat accelerated by the use of alum, and after the gypsum has been fully burnt, it is put into the bath of alum. After this it is dried and again burnt, and finally ground to a very fine powder.

CEMENT MORTAR

In these days many bricks are laid in cement mortar. This is more expensive but a good deal stronger than the ordinary lime mortars. A strong cement mortar might be two volumes of sand to one of cement, while a weak cement mortar might have five volumes of sand to one of cement.

The amount of cement to be used in the mortar depends largely on the amount of waterproofing necessary. If the joint is to be made under water or where exposed to much water, a rich mixture of cement should be used, that is, the mixture should not be more than two of sand and one of cement. For ordinary building construction, if the walls are set in cement mortar, a 4 to 1 or 5 to 1 mix is often used.

The sand and cement are generally mixed in a mortar mill (i.e., two heavy rollers), because this is much quicker and better than hand-mixing. A type of roller mill is shown in the drawing. (*Plate 15.*)

A typical analysis of the ash in coal may contain from 40 per cent to 60 per cent of silica, 20 per cent to 30 per cent of alumina, 5 per cent to 20 per cent of iron oxides, together with some magnesia, calcium, and other impurities. It will therefore be seen that to mix in some good clinker ash with the sand and

cement will not do any harm, but will increase the bulk and cheapen the cost. This does not mean, of course, that any rubbish or yard cleanings can be thrown into the roller mill, as these are bad and will certainly reduce the quality of the mortar produced.

As soon as the cement and sand are mixed together they should be used, otherwise setting commences, which makes the mortar harder to trowel into position. All cement mortar will, of course, readily harden under water, and is therefore a hydraulic cement.

QUESTIONS ON CHAPTER XVI

What is lime made from ?

What is chalk ?

What is mortar ?

What are (1) Calcium limes, (2) Magnesium limes ?

What are hydraulic limes ?

What is " Plaster of Paris " ?

What are (1) lime mortar, (2) cement mortar ?

CHAPTER XVII

BRICKS

Bricks—Wirecuts—Famous Brick Buildings—Different Clays—Pug Mill—Sand Lime Bricks—Colour of Bricks—Refractories—Analysis of Fireclay Bricks—Chrome—Segar Cones.

BRICKS AND THEIR MANUFACTURE

BRICKS have been used by man from very early times, and brick-making is one of the oldest crafts known. The well-known Bible story of how the children of Israel made bricks in the land of Egypt shows that many centuries before the Christian era began, the ancients knew how to make and use bricks. It is probable that in those days the bricks were made of cut straw and mud. The mixing may have been done by throwing these materials into pools of water, and treading them out until they were sufficiently well mixed together to enable them to be moulded into shape and dried in the sun. I have seen many sun-dried bricks made in Spain within the last 20 years.

It is probable that the walls round the ancient city of Babylon were built of bricks, and although in the very early stages the bricks were probably made by squeezing the puddled clay into separate moulds, and drying the material in the sun, there is a good deal of evidence available that the art of burning bricks was known to the Greeks and Romans more than 2,000 years ago. We know that the Romans were acquainted with the method of burning bricks in kilns before Julius Cæsar and his armies invaded this country 55 B.C.

The great wall of China was built to keep out the wandering Tartars, that race of people who were so pugnacious and insistent on having their own way that even today we have the saying "He is a regular Tartar." When we say that bricks were used in building the Great Wall, it should be remembered that we allude to a brick as a shape made from a dried clayey substance, and that we do not mean to infer that if the reader is fortunate enough to pay a visit to China he would find a wall several hundreds of miles long, made of 9 in. \times 4½ in. \times 3 in. bricks nicely laid in lime mortar. Still, these examples do serve to show that brick-making has been long practised.

It is strange that although the Romans certainly knew how to make building bricks, and probably used them during their occupation of this country for

building cities, bridges and walls, we have not many examples left with us. About 600 or 700 years ago brickwork began to flourish again in England. Some excellent brickwork can be seen at St. Albans, and many old English brick buildings erected between the thirteenth and seventeenth centuries are still worthy of notice as showing the beauties of the brick-maker's art.

St. James's Palace, Hampton Court, The Temple, Kew Palace, St. Pancras Station are all excellent examples of what can be done with bricks. In more recent times we have Westminster Cathedral, and I remember seeing in Copenhagen a church built entirely of brickwork which showed the remarkable skill of the architect.

A fair average composition of a good brick earth may be silica SiO_2 , $\frac{3}{5}$ ths; alumina Al_2O_3 , $\frac{1}{5}$ th; and the remainder iron oxide, magnesium, calcium (i.e., chalk or limestone), some manganese, and some potassium. If there is too much lime or chalk the bricks tend to be of bad shape. If there is too much sodium or salt, the bricks are also of bad shape, and dampness causes efflorescence, that nasty-looking white coating which is often seen on new buildings. For this reason, brick earths, found near the sea, although they may contain a good plastic clay, are often unsuitable for use in brick-making.

DIFFERENT CLAYS

Different kinds of clays are used in the making of bricks, but whatever type of brick is being made the clay must be sufficiently plastic to allow it to be moulded, and should have the quality of not shrinking too much when it is dried and burned. By plasticity we mean the property of a substance to yield to pressure and to remain in the shape after the pressure has been removed. A perfect idea of what plasticity means can be got by considering the properties of plasticine, with which every child plays.

After the clay has been quarried and the flints and stones removed, it can be weathered during the winter months. The idea of this weathering is that it breaks up or disintegrates the mass, and a better and more uniform brick can thus be produced. Instead of weathering, materials are sometimes mixed together in wall-mills and then allowed to settle. The water is drained off, the residue covered with ashes, and the whole mass left to disintegrate. Sometimes, in order to save time, a part or whole of this weathering is dispensed with, and the brick earth or clay is crushed or ground by rollers.

IN THE PUG-MILL

After the weathering or grinding process is completed, the mass is then taken to a pug-mill, where it is kneaded into a plastic shape. The action of this

pug-mill has exactly the same results as are obtained by the mother who still makes her own bread, for she kneads the dough before putting it into the loaf tins. The pug-mill does precisely the same to the materials from which we make the bricks. It thoroughly mixes them together.

This mixed material is now ready for the moulds, and the bricks may be hand-made or machine-made. Nearly all bricks these days are machine-made. After the plastic material has been shaped in the moulds, the shapes are stacked under cover to keep them dry before they are burned. Sometimes this burning is done in a clamp, which is really a framework made from underburnt bricks. Inside this clamp there are alternate layers of bricks and breeze. Faggots are placed in the fireholes, and the burning may continue for a month or so.

Sometimes kilns are used instead of clamps. In these days, when scores of millions of bricks are made, briquetting presses are used instead of hand-moulding. The shapes are taken to special kilns. (*Plate 16*).

In the wire-cut process, the plastic material is passed out of the mixing-mill or pug-mill through an opening about $9\frac{1}{2}$ in. wide by 5 in. high. The section passes through a machine which has wires so arranged as to cut off strips about 3 in. long. The shapes then pass on to the kilns. Although these wire-cut bricks are regular in form and easy to produce, they are not very popular with lots of people as they are difficult to cut, the appearance is often poor, and they have, of course, no frogs.

In *Plate 16* the various stages in the manufacture of bricks, and some of the machines used are illustrated.

Many millions of sand-lime bricks have been made in Britain, America and Germany. Although, for building purposes they are not so good as the better-known standard Flettons, London stocks, or Staffordshires, there is no doubt that many satisfactory buildings have been put up in these sand-lime bricks.

The fine siliceous sand and a high-calcium lime are thoroughly mixed together, the shaping and pressing is done in special toggle-operated machines, known as briquetting machines. These exert a pressure of as much as five tons a square inch on each side of the brick or briquette. After being thoroughly pressed, the bricks are taken to hardening cylinders, and steam treated.

Here are some useful figures to remember in connection with brickwork :

A thousand bricks $8\frac{3}{4}$ in. \times $4\frac{1}{4}$ in. \times $2\frac{5}{8}$ in. if closely stacked will occupy about 58 cubic feet. If the same number of bricks are loosely stacked they will occupy about 70 cubic feet. These 1,000 bricks will probably weigh about 55 cwt., but if they are 9 in. \times $4\frac{1}{2}$ in. \times 3 in. they might weigh 66 cwt.

The weight of a cubic yard of brickwork is approximately $1\frac{1}{2}$ tons.

A rod of brickwork measures $16\frac{1}{2}$ feet square, if the wall is $1\frac{1}{2}$ bricks thick, contains about $11\frac{1}{3}$ cubic yards of brickwork, and if laid in mortar requires about 4,350 bricks.

Bricks vary considerably in weight, but, for most purposes, it is near enough to assume that a square foot of brickwork, 9 in. thick, will weigh 90 lb. ; a square foot in a $13\frac{1}{2}$ in. wall will weigh about 135 lbs.

A cubic foot of brickwork requires 17 standard bricks.

A common brick must have sufficient strength to carry the loads, should be regular in shape, free from cracks, entirely close grained, free from lime, stone or pebbles and should give a metallic ring when hit by a hammer. A dull thud is a definite indication that the brick is soft. A brick when soaked in water should not absorb more than $1/6$ th of its own weight.

COLOUR OF BRICKS

The colour will depend largely on the chemical nature of the material from which the brick is made. For instance, if the clay contains iron oxide, but is otherwise free of alkalies, it should be a clear, bright red colour. Staffordshire bricks, on the other hand, generally contain alkalies, and are usually a dark, bluish shade. The presence of carbonate of lime bleaches bricks and the well-known London stocks have a definite yellow tone.

A firebrick is a brick made from fireclay.

A silica brick contains more than 92 per cent of silica.

A refractory material is one which is difficult to fuse, soften or melt by heat.

Ganister is a silica clay containing more than 75 per cent silica ; some good ganisters contain over 95 per cent of silica.

Silica is a hard, glassy, flint-like material. Some sands contain more than 85 per cent silica (SiO_2). The silica becomes soft at about 1,500 deg. C., glassy at about 1,700 deg. C., and melts at around 1,750 deg. C. For this reason it is the principal material used in making firebricks.

Alumina is an oxide of aluminium. It has a melting point of 2,050 deg. C., and is the material largely used with silica for making the bricks which line furnaces and the combustion chambers of boilers.

When firebricks are subject to a great heat there is a tendency for the bricks to crack and splinter. This is called spalling.

For lining furnaces where there is a high temperature, special heat-resisting bricks made from clays of a refractory nature are required. In earlier chapters we have shown that blast furnaces, cupolas and refining furnaces are all lined with firebricks, or, as they are sometimes called, refractory bricks.

The heat-resisting qualities depend on the silica, alumina and iron oxide in the clay. A good chemical analysis for fireclay bricks is :

Silica	55 to 70 per cent
Alumina	25 to 35 per cent
Iron oxide	2 to 3.5 per cent
Titanic acid	1 to 1.5 per cent
Lime, magnesia and potash in small amounts.				

A poor quality fireclay brick may show signs of fusion and deformation at 1,300 deg. or 1,400 deg. C., but a first grade fireclay brick will not show much sign of fusion or softening until a temperature of about 1,700 deg. C. has been reached. This corresponds to roughly 3,000 deg. F.

For some metallurgical jobs bricks containing as much as 95 per cent or 96 per cent of silica are used. These are, of course, firebricks, but in order to distinguish them from fireclay bricks which contain from 25 per cent to 35 per cent of alumina, we generally designate them as silica bricks. They are made from quartzite, sandstone or silica-sand, and are burned at a higher temperature than firebricks. These high-silica bricks keep their strength and shape up to higher temperatures than the firebricks, which contain less than 70 per cent of silica.

When we were discussing steels we drew attention to the acid steels and basic steels. The ordinary firebrick, which contains between 25 per cent and 35 per cent of alumina, gives the brick a basic reaction, and for this reason the fireclay brick and the silica brick are used to resist the action of the siliceous and other acid slags.

For lining Bessemer converters and open-hearth furnaces which are subject to the action of basic slag, magnesite bricks are often used. These are sometimes called basic bricks. They are made from magnesite, which is nearly a pure magnesium-carbonate, the best supplies coming from Greece and Austria.

The temperature range at which deformation and softening starts is fairly wide. A fair quality magnesite brick will show signs of trouble at less than 1,700 degs. C., while a first-grade magnesite brick may not show signs of softening until around 2,000 degs. C. has been reached.

Sometimes in furnace construction the conditions are such that a firebrick which is neutral can be used. These can be made of bauxite or chromite. The bauxite, which often contains more than 50 per cent of alumina, is burned, crushed and mixed with fireclay. Such bricks will resist fairly high temperatures, but unfortunately they shrink a lot and are not very much used.

ADDING CHROME

Most neutral bricks are made by mixing chromite either with fireclay or with manganese. Such bricks may contain about 30 per cent chrome, 35 per cent magnesite, 10 per cent iron oxide, 15 per cent alumina. Generally the chrome content is something between 30 and 40 per cent. Although manganese-chrome bricks resist the action of slags and hot gases, they are not generally considered safe for temperatures as high as those which can be used where the lining is first-grade quality magnesite brick.

One of the advantages of lining with high-alumina bricks is that they have about four times greater conductivity value than ordinary fireclay bricks.

They have a good consistency of volume, excellent resistance to spalling and basic slag attack, a high heat-resisting capability, about 1,700 deg. to 1,800 deg. C. The alumina content is generally between 45 and 70 per cent, most of the balance being silica. These bricks are used in the combustion chambers of marine boilers and for lining lime and cement kilns.

The method generally used for testing the temperatures which bricks, made from a given mixture, will stand was introduced by Dr. Segar in 1886. Segar cones are actually three-sided pyramids about $2\frac{1}{2}$ inches high. They are made of finely-ground mixtures of a definite composition, and according to the mix used the cone or pyramid will slowly bend over from its upright position if placed in a furnace or oven.

The different cones are numbered, and each number represents the temperature at which the Segar cones will bend over, so that the top of the cone is nearly level with the base. The squatting temperatures of a few of these cones are as follows :

Segar Cone No.	Cent.	Fahr.
1A	1,100°	2,012°
10	1,300°	2,372°
20	1,530°	2,786°
30	1,670°	3,038°
40	1,920°	3,488°

There are all the intermediate cone numbers, each having its own value. A cone of the material from which the firebricks will be made is tested against Segar cones at the same time. One is about 20 to 30 deg. C. below the expected standard of the piece being tested, another is a number which corresponds to about 30 deg. C. higher than the specimen being tested, and the other half-way between.

QUESTIONS ON CHAPTER XVII

How long have bricks been used by man ?

What materials does a " good brick earth " contain ?

What is efflorescence ?

What is the wire cut process ?

What effects the colour of bricks ?

What is the analysis of fireclay bricks ?

Is chrome used in making bricks ?

What is a Segar Cone ?

CHAPTER XVIII

COAL

*Origin of Coal—Peat—Lignite—Bituminous Coal—Ash-Content—Heat Value
—Coal Tar—Benzol—Town Gas—Ammonia—Dyes.*

COAL AND ITS BY - PRODUCTS

HUNDREDS of thousands of years ago, the coal which is now being mined was alive. Through the scores of centuries the trees and vegetable matter passed through various chemical stages in which the ground vegetation took carbon from the air under the influence of sunshine, so that coal can really be considered as a sort of bottled sunshine. The study of geology which deals with the composition, structure and physical history of the rocks in the earth, is fascinating.

GEOLOGICAL HISTORY

The student of history divides England's story into Norman, Plantagenet, Tudor, Stuart, Hanoverian, and Windsor Periods. An architect studies building forms in categories known as Tuscan, Doric, Ionic, Corinthian, and Composite. In like manner the geologist divides up the Earth's story into Ages or Periods. Each of these may have lasted tens of thousands of years, some of these may have lasted hundreds of thousands of years, some of them may have lasted even millions of years. The main divisions are known as the Primeval Age, Primary or Paleozoic Age, Secondary or Mesozoic Age, Tertiary or Cainozoic Age, followed by the Pleistocene Age. Each of these main periods of time is divided into sub-periods or sections.

In the Primeval Age, which most geologists consider occurred scores of millions of years ago, the earth began to cool and the igneous or fire-rocks began to form. During the succeeding Primary or Paleozoic Age, the sponges, scorpions, fishes, ferns, forests, insects, and some of the earliest forms of reptiles appeared. This Age is divided into the Cambrian, Ordovician, Silurian, Devonian, Carboniferous, and Permian Periods, and through the centuries which each of these periods occupied, the slates, limestones, sandstones, and coal measures which resulted from the decaying forests and vegetation were formed. Through the multitude of years between that Age and our own

the reptiles, fish, crocodiles, flowering plants, elephants, cat forms, such as the leopard, tiger, and lion, all appeared.

During these ages of time, the sandstones, blue clay, marl, peat and chalk had been formed. We are not called upon here to discuss this question further, but it is interesting to let the mind wander over the changes which have taken place on the surface of the earth during the time which has elapsed since the coal which we know in its present carbonaceous form formed part of the forests or vegetation.

There are two points of view as to how the present coal seams were formed. Some authorities consider that vegetable matter drifting downstream was deposited at the mouths of rivers. Those who believe in this theory point out that both peat and lignite have been found in river deltas, and that the fossil remains of creatures which have lived in the sea have been found in the rock strata both above and below the coal.

The other point of view is that the deposits of coal accumulated in the swamps where the vegetation and trees originally grew. In favour of this argument we know that in certain coal seams the roots of trees have been found in the clay under the coal. It seems impossible that this could have happened if the trees had been washed down the rivers.

Nearly everybody knows that peat is largely used in Ireland as a fuel. Like coal, it is formed of forest and vegetable matters, in fact, it is probable that peat is the first stage in the formation of coal. Some authorities think that when this vegetation was growing, the rate of growth was much faster than in these days. It is explained that there was regular and abundant rainfall, probably a temperate climate, and that because of these things there was little evaporation of water from the ground and there was more carbon-dioxide in the air. As the years passed by there was an accumulation of plant material, and decay took place because of the action of very small live organisms.

ORIGINS OF PEAT

It is probable that the peat bogs began round a lake, and that as the ground sank the plants near the edge decayed. One type after another would become submerged. Other forms would grow and the process of growth and decay of the plants would go on. The nature of the wood and the vegetable matter became changed because of the very small organisms and fungi and masses. As this decaying wood sunk further below the surface of the ground the life of these organisms was retarded or stopped after the woody matter had only become partly decomposed.

It is this partly decomposed forest vegetation which we now know as peat,

and which makes a very good fuel. The woody fibre arrangement of the original timber is still to be seen in peat, which, although an excellent fuel, contains more water and less carbon than coal, and even when peat is compressed it has only about one-quarter of the heating value of good coal.

Lignite is also formed from the vegetation of the past ages, and can be considered as a sort of intermediate stage between the formation of peat and coal. Lignite is a brown soft coal, and contains less than 70 per cent of carbon. Large quantities of lignite are found in Germany, Czechoslovakia, and in the U.S.A.

Some of the higher lignites are very near soft, bituminous coal. They are dark brown or nearly black in appearance. Most lignites contain quite a lot of water as they come up from the ground, and if they are left in the open air for any considerable time to weather, they tend to disintegrate or break up.

Coal is the final stage reached by the decayed and compressed former forest and vegetation. Through countless ages, chemical changes have taken place, so that the coal is now mined as a brittle, black rock, which may contain anything between 70 per cent and 90 per cent of carbon. A large proportion of the hydrogen and oxygen which was present in the original timber has gone. Roughly speaking, coal can be divided into two kinds; soft or bituminous coals and hard or anthracite coals.

BITUMINOUS COALS

Bituminous coals burn easily with a flame and produce an amount of smoke which varies considerably with the various grades of coal. A good steam coal, which is really a semi-anthracite or something between bituminous and anthracite, actually contains hardly any bitumen, and for this reason gives off very little smoke. The heating value of a coal depends on the amount of carbon it contains, and since this semi-anthracite coal has a high proportion of carbon, it has a high heating value. For this reason it is much used on ships and in boiler plants. Although more expensive than the lower grade bituminous coals, it is more economical to buy because a larger amount of steam can be raised for each ton of coal burnt.

A good semi-anthracite coal will have a heating value round about 15,000 British Thermal Units per 1 lb. of coal.

In order to find the heating and general properties of coal, we must know how much carbon in a fixed form the coal contains. Quite a lot of information can be found from what is known as proximate analysis. The amount of moisture, ash, and volatile matter is determined by test and the fixed carbon is the remainder.

As mined from the ground, coal contains a good deal of moisture, which is

generally known as pit-water. A sample of known weight after being ground very fine is allowed to dry in the air. This air-dried sample, after being kept at a temperature of about 105 deg. C. in an oven, is taken out, cooled, and weighed. The moisture content in the coal will clearly be the difference between the weight of the original sample and the weight of the dried coal.

When coal is burnt, the volatile matter, consisting of the gaseous hydrocarbons, and carbon-monoxide with oxygen, distils off. This distillation does not begin until a temperature of more than 350 deg. C. is reached, but when the temperature is as high as 800 deg. C. the volatiles are quickly burnt off. To determine how much volatile matter there is in a given coal, the method generally used is to heat one gram of powdered coal in a crucible at a temperature of 950 deg. C. for about seven minutes. The volatile matter and the moisture from the coal are burnt off, and by weighing a combined loss is found. By another test already described the moisture content will have already been found, so that the volatile matter can now be found by difference.

To find the amount of ash, another sample is taken and burned in an uncovered crucible until the carbon contents are all burnt off, and the amount of ash left in the crucible can be found by weight. By these tests we know the moisture content, the amount of volatile matter, and the percentage of ash, so that by adding these three together the difference between this total and 100 per cent determines the percentage of fixed carbon in the coal. Once this approximate analysis is known, the expert is in possession of sufficient information to enable him to judge within reasonable limits the quality of the coal.

CONTENT OF COAL

By more competent analysis, called the ultimate analysis, the fixed carbon, hydrogen, nitrogen, sulphur, phosphorus, and oxygen content of the coal can be found. Once these values are known, we can find by formulæ the heating value, or, as it is technically called, the calorific value of any particular coal.

Dulong's formula is :

$$\text{B.T.U. per lb.} = 14,600C + 62,000 \left(H - \frac{1}{8}O \right) + 4,300S$$

where C is the carbon in 1 lb. coal.

H is the hydrogen in 1 lb. of coal.

O is the oxygen in 1 lb. of coal.

S is the sulphur in 1 lb. of coal.

Coal is much more dense than peat, and it is quite probable that a coal seam which is now 10 ft. thick, was once a peat bed 100 ft. thick. Anthracite is a hard coal much used in kitchen boilers. It does not soften or cake together when burned, and gives off very little smoke. Because it has a very high carbon content anthracite gives out a great heat and burns with a short blue flame.

Although the process of formation from vegetable matter of the peat and lignite stages to the coal seam has probably taken millions of years, it is less than two centuries ago that scientists were able by their observations and experiments to put forward the now generally accepted theory that the coal seams of today were formed from the peat bogs which existed in the dim and distant ages. It is true that coal as a fuel was known to the ancient Greeks two or three centuries before the Christian era, and it seems to be well established that the Romans used it for fuel in England.

We have seen in previous chapters that iron and bronze were used by primitive men long before those times, so that compared with those metals, coal is a comparatively recent discovery; and yet this is not altogether true. We should have said, coal used as a fuel is a comparatively recent discovery, for jet, which is a form of coal, was used for the making of ornaments in prehistoric times. To this day brooches of Whitby jet can be bought.

The rocks most common in coal measures are sandstone, limestone, shale and fireclays, while coal deposits with beds of iron are also often found. Due to subterranean movements which have taken place over the years, the seam is frequently found to be faulted, troubled, slipped, or hitched. All coal miners know that coal is found in rough cubical pieces which have shiny and glossy surfaces. These were caused by earth movements, which account for the folding and dislocation of coal stratas. A section showing a typical method of coal mining is shown in *Plate 17*.

Coal is still the material best known and most used for fuel, but mankind in the search for materials from which energy can be obtained, has used wood, peat, coal, oil, and even harnessed the power of wind, tide and water. Windmills have not been much used in this country, but in Holland they are a common sight. Water power for driving electrical generators is not so much used in England as in Scotland. In Norway, Sweden, Switzerland and the U.S.A. cheap power is obtained by using the stored-up energy of falling water. The great masses of sea water moved by the tides are for the most part wasted. Engineers know that in some places it would be possible to make use of this tidal power, but generally the cost of the scheme is very high.

WOOD AS FUEL

In some parts of Australia and America, the high price of coal has made the use of wood almost general, both for domestic heating and even as a fuel supply for the steam boilers in the mines and industrial plants. The mighty power of the sun is still not used directly to any very great extent, but may be some day. Oil is being very much used as a fuel in all kinds of industrial plants. Although coal itself is still burnt in the grate as a fuel, there has been

a very marked tendency in recent years to get better value by turning the coal into coke and collecting the other valuable materials which coal contains.

With suitable plant and equipment, it is possible to get out of 100 tons of coal, 70 tons of coke, 17 tons of crude liquor, and nearly 6 tons of crude tar. From the coke we get domestic and industrial fuel. From coke and coal gas our town gas is produced. Benzene and Naphtha, sulphate of ammonia, and liquid ammonia are all made by treating this by-product of coal.

In addition to being used on roofing felts, for protecting steel against rust, and for the making of roads, coal tar is the source from which pitch is made. How many schoolboys remember the sight of the boiler during road spraying, and the hidings they got for allowing their boots and clothes to be sprayed while the operations were in progress.

COAL TAR PRODUCTS

There seems to be no end to the products made from coal tar : benzol and motor spirits, the creosotes used for protecting wood sheds and fences (the sleepers which carry our railway tracks, are soaked in creosote). We have Bakelite doorknobs, finger panels, wireless cases, calendar holders, telephone frames, penholders, ashtrays, and the synthetic resins which are used in the making of this plastic material receive a contribution from coal tar.

Carbolic acid and many of the disinfectants find their origin in coal tar. It even contributes to the making of explosive used in mining and making war.

In the textile industry many of the dyes are made from coal tar.

Although black in itself, it is really the essence of stored-up sunshine, and therefore contains all the colours of the spectrum. Naphthol black, aniline blue, alizarine orange, naphthol yellow, brilliant greens are all colours which the dyeing industry obtains from this all-providing coal tar.

Some of the main products of coal and coal tar are shown in *Plate 17*. The priceless treasures formed by Mother Nature during the passing of the countless centuries are now at the disposal of man.

QUESTIONS ON CHAPTER XVIII

What is coal and how is it formed?

What is peat?

What is lignite?

Was coal used by the Greeks and Romans?

What is the heating value of a semi anthracite coal?

What is coal tar?

What are some of the products made from coal tar?

CHAPTER XIX

TIMBER

*Protection of Timber—Dry Rot—Moisture Content—Creosote—Star Shakes
Timber—Hardwoods—Soft woods—Faults in Timber—Strength of Timber—Decay*

TIMBER AND ITS USES

WITHOUT doubt wood is still one of the most used materials. It was probably the first material used by man for making himself a shelter and providing fuel. When the tree which he had felled lay across a stream, man had formed the earliest bridge. By sitting astride a trunk or branch, prehistoric man paddled his way down the streams. The first rough canoes made it safer for our forefathers to move down the crocodile-infested rivers. The kindly trees probably supplied him with at least part of his food.

In these days, iron, steel and concrete have displaced timber to some extent in the constructional field, but even today timber has a thousand and one uses. *Plate 18* shows some of them. In locations where there is ample supply of timber there is often a scarcity of iron and steel. Frequently there is no possible means of transport, and the cost and time required are some of the factors which make it desirable and possible to use wood as a constructional material.

ADVANTAGES OF TIMBER

There are some cases where timber has a definite advantage over iron and steel. Timber piers and wharves alongside which boats and ships bump and knock are often made of timber. It stands shocks and bumps a good deal better than either iron or concrete, and in the case of damage, can often be more quickly and easily repaired. In recent years there has been a tendency to build piers, wharves and jetties of cast-iron or steel or reinforced concrete and then protect them from the bumps of ships by building a timber framework against which the cargo-carrying vessels can be moored and fastened.

The principal drawback to the use of timber is the fire risk. It is, of course, a fact that many timbers are not suitable for resisting the ravages of time when exposed to air and water. Some of the characteristics of various woods will be dealt with later on in this chapter.

If we happen to be near when a tree trunk has been sawn through, and

interested enough to examine it, we should find that there are really three separate main parts. The pith or heart or centre of the tree tends to dry up as the tree gets old. Around this pith is a wood fibre which is really a series of long hollow tubes arranged in rings. Each year one of these rings is formed, and for this reason they are known as annual rings. From the heart of the tree and radiating out are another series of tubes. These are known as medullary rays. The outside of the tree is the bark. The age of the tree can roughly be found by counting the number of rings, and in museums sections of trees are to be seen which show that they have reached the venerable age of nigh on a thousand years before being cut down. I know a yew tree in a village churchyard at Ninfield, Sussex, which is reputed to be around 700 years old. Often, as I pass, I try and conjure up visions of the happenings during the years which have passed since that old fellow was a tender young sapling. The Tudors have come and gone. Raleigh, Drake, Cromwell and his Ironsides, Wellington, Nelson, Disraeli, Gladstone, and General Booth have all contributed their part to the nation's history, and passed on, yet here and in many English villages, these wonderful trees remain.

The strength of wood depends on quite a number of things, its density and weight, whether it is wet or dry, seasoned or unseasoned, and whether it is defective or sound timber. The weight and density depend on the rate of growth which can be measured by the spacing of the annual rings. In some of the very hard woods the annual rings are not easy to see, as they are so narrow and close together. This shows that the tree has grown very slowly, and that is why it is a hard wood. Hardness, as we have seen in previous chapters, refers to the resistance to indentation and the resistance to abrasion or wear. Generally speaking, therefore, the heavier and denser a wood, the stronger it is.

Now the weight of wood varies both with the class of tree and the amount of water the wood contains. What is known as green wood will generally contain between 50 and 70 per cent moisture. Air-dried wood or air-seasoned wood might contain anything between 10 and 20 per cent of moisture. Kiln dried will contain less than 10 per cent of moisture. Well-seasoned timber is much more durable than a green or only partly-seasoned wood.

Woods have all kinds of values. There is the strength value, which means the ability to resist a force or a load; calorific value, which is the heating or fuel value of the wood; the hardness value, which is its ability to resist wear; and a cleaving or splitting value. Some woods are able to resist the destroying work of borers and insects.

The best time for felling trees, which are to be used on building work, is after they have reached full age. If cut too young, the wood will be relatively soft, liable to decay, because of the quantity of sap included in it. On the other

-TIMBER BUILDING-

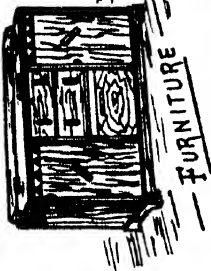
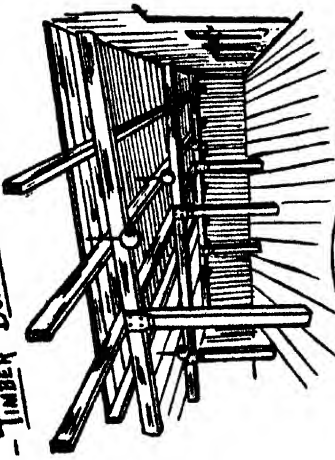

FURNITURE

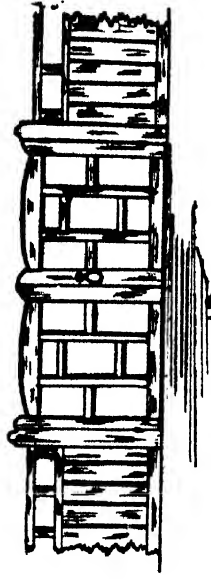
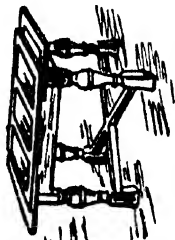

FENCES
GATES

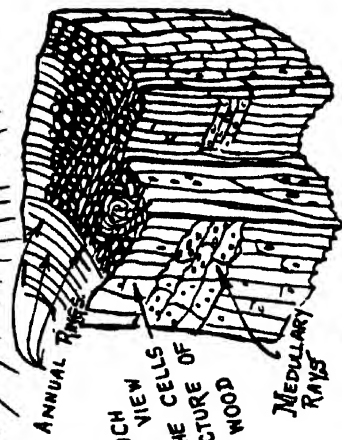

VERY MUCH ENLARGED VIEW SHOWING THE CELLS OF AND STRUCTURE OF A SOFT WOOD

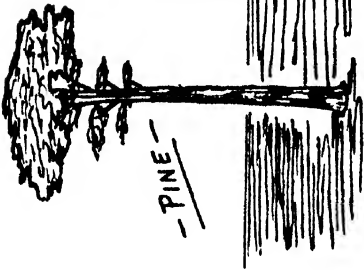

-PINE-

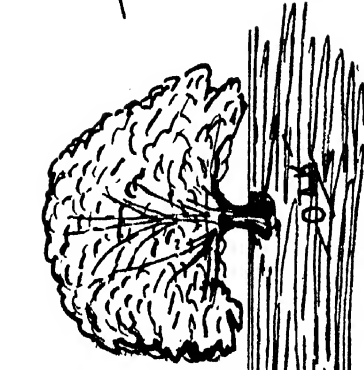

OLD

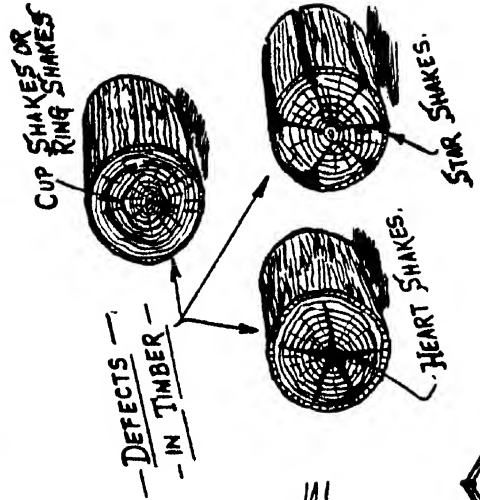

CUP SHAKES OR RING SHAKES

DEFECTS IN TIMBER

HEART SHAKES

STAR SHAKES



FORMWORK STAIRS FOR CONCRETE STAIRS

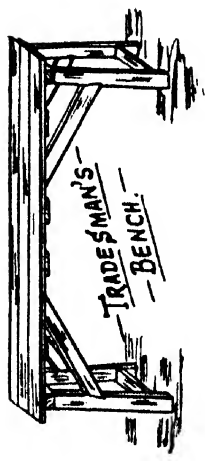

TRADESMAN'S BENCH

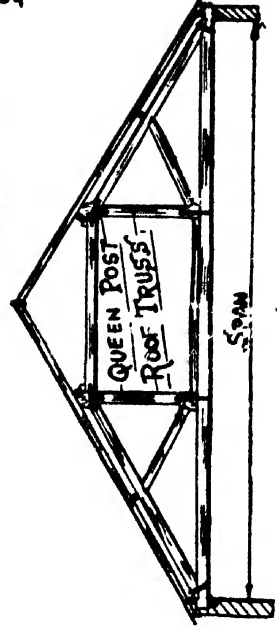

QUEEN POST ROOF TRUSS

SPAN

hand, if the tree is not cut until the heart wood is beginning to decay, the timber will be weak, crisp and brittle, and not nearly so elastic as it would have been if cut at the proper time. The best time for cutting trees is when the sap has ceased to circulate, and this is either in mid-summer or mid-winter.

CONIFEROUS TREES

Coniferous trees generally produce softer wood than trees which bear leaves. Pine, for instance, is much softer than a good British oak. The oak tree contains a valuable acid known as tannic acid. This acid is used medicinally for burns and is also used for the tanning of leather. For this reason, the bark of an oak tree is sometimes stripped off in the spring when the bark is good, while the tree is not felled till the following mid-summer.

Unfortunately, timber is liable to many defects. These take the form of cup shakes, heart shakes, star shakes and knots. A knot is really a structural defect caused by the cross graining during growth. Pitch pine is particularly liable to the fault known as cup shakes. These are really cracks which take place along the circular annual rings. Heart shake is a crack or opening of the timber which passes through the centre or heart of the tree. If there are a number of these cracks radiating from the centre they are called star cracks.

In important work, star shakes might make it practically impossible to use any part of the tree. I have known cases where good-sized oak trees, which it was intended to use as crane jibs and boom members of heavy mechanical shovels, had to be rejected for this purpose because of heavy shakes. For a job such as this, a few knots here and there, provided that they were not very large, would not be a very serious defect. A good freshly-cut timber smells quite sweet, and any timber inspector knows that if the smell is unpleasant, it is extremely likely that the tree has become decayed.

Sometimes the tree is not just quite large enough to produce the square stick desired. The lower end of the tree may be all right, but towards the top end one or two edges of the balk or stick of wood may be the bark of the tree instead of being the wood. These edges are called waney edges. For some jobs a relatively small amount of waney edge is not at all a serious matter. It would, of course, be possible to cut a smaller size balk so as to show all square edges, but this would be a waste both of material and time.

An experienced inspector knows whether he can allow waney edges or not.

THE SOFT WOODS

Generally speaking, the soft woods are the fir timbers—that is, the pines and the spruces. The soft woods have the distinct annular rings, while in the

hard woods the annual rings are much closer together. Some of the soft woods are:
Alder.—This is easy to work, very light in weight, not suitable for building work except in the form of plywood, where it is very commonly used.

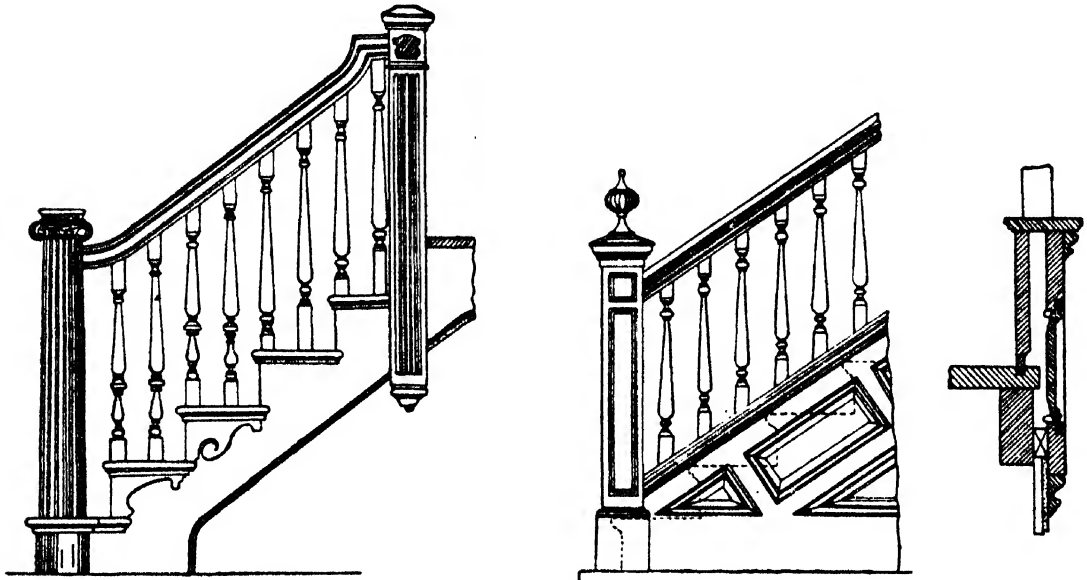

INTERNAL JOINERY

Northern pine.—One of the most common woods used in the building trades.

It is sometimes known as Norway pine, Baltic pine or Scotch fir; it is largely shipped from Russia, Norway, Finland and Sweden, and is much used in the joinery work of buildings, both internal and external. It is close grained and weighs about 36 lb. to the cubic foot.

Yellow pine or White pine.—Sometimes known as Weymouth pine. This tree grows around the middle states of North America and Canada, and is chiefly exported from Quebec. The medullary rays are very difficult to see.

It is remarkably free from knots, straight grained, shrinks very little after being seasoned, is easy to work, and can be cut in all directions. It is not very suitable for exterior work, as it does not stand up well to the weather; but is much used on internal joinery and for pattern making in the engineering trades.

Pitch pine.—This wood has great strength and durability. Unfortunately, it is very hard to work. As it grows in long trees, good heavy, long balks can be obtained, sometimes as big as 18 in. or 16 in. square and 50 ft. or 60 ft. long. It is much used for piles, jetties and wharves.

It is very heavy wood, weighing something like 45 lb. a cubic foot. Because of its beautiful grain, it is sometimes used for ornamental joinery work, although it is a more expensive wood than the Northern pine or the yellow pine.

Oregon pine.—This is a reddish yellow in colour, somewhat like pitch pine. It grows to a tremendous height, and is generally straight-grained. It is difficult to plane or saw, and because it is very strong, it is used for heavy constructional work. Oregon pine is sometimes known as Columbian pine and sometimes as Douglas fir.

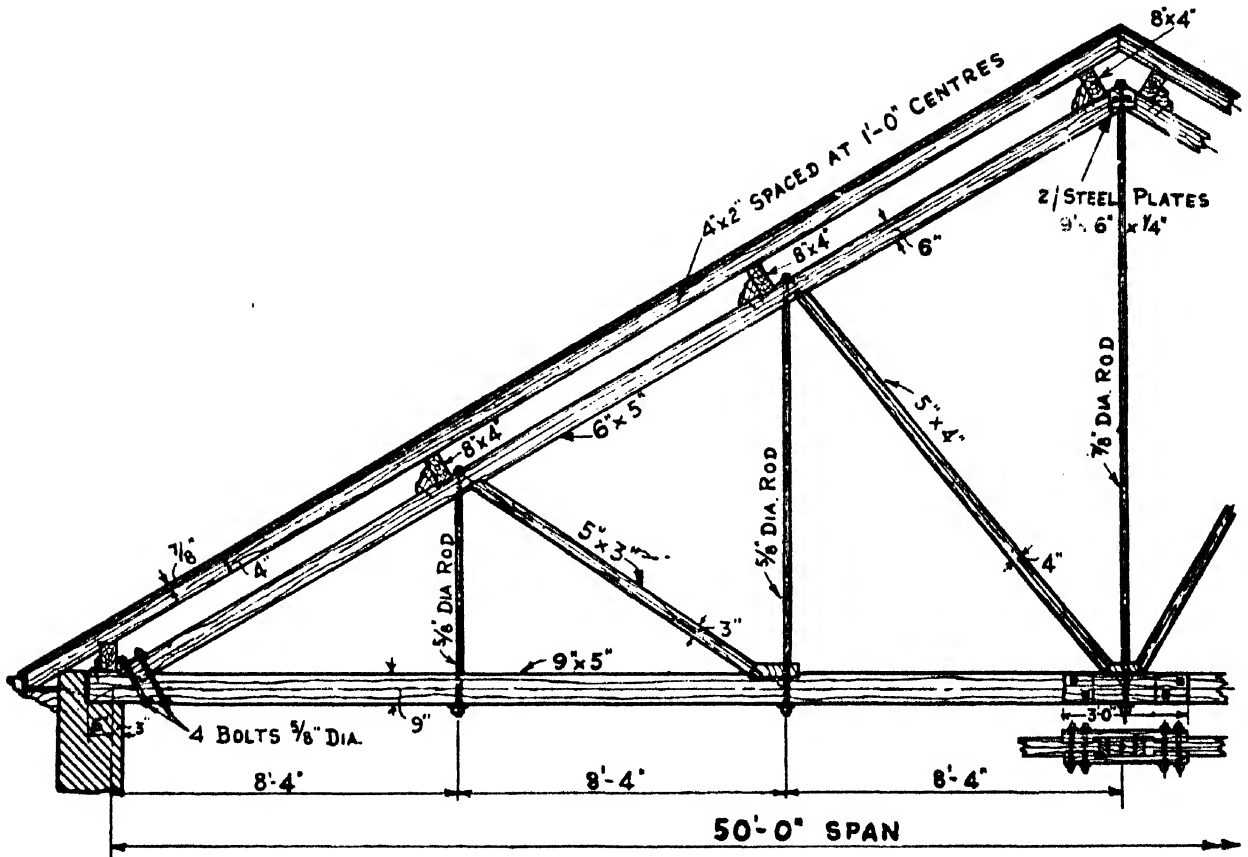

COMPOSITE ROOF TRUSS, 50' 0" SPAN

White fir or Spruce.—A light wood weighing only about 32 lb. a cubic foot ; but strong and elastic. Usually called white deal. The wood is liable to warp and twist. The knots are very hard ; but where there are no knots, the wood can be easily planed and sawn. It is much used for kitchen joinery, as dressers and tables ; and although not very durable when exposed to wet and dry weathers, it is frequently used because of its relative cheapness. The best white deal comes from Russia and Oslo, in Norway.

PROPERTIES OF OAK

Turning to the hardwoods, oak is the most durable timber grown in the Northern latitudes. It has good elastic properties, is strong, hard and tough, and is much used on heavy engineering work.

Oak is heavy, since it weighs more than 50 lb. a cubic foot, and is difficult to work.

It warps considerably, and is somewhat liable to "shakes." Oak also contains gallic acid, and this, although it increases the durability of the wood, corrodes any iron spikes or bolts. This is one reason why wood pegs are used instead of ordinary mild steel bolts; but, in recent years, the production of bolts made of stainless steel has made it possible to make good strong connections and joints. The annual rings are clear to see, and so are the medullary rays.

Although, as a rule, the grain is fairly straight, the old oak is often a gnarled and twisted tree. The Baltic oak, Austrian oak and American oak are all quite good timbers, but none of them are so strong or durable as British oak.

This wood has a sort of silverish grain, which can be made to take a high and durable polish.

Ash.—This wood is of a brownish-white colour. It is easily worked, close-grained, and, because of its toughness and elasticity, is used for hammer shafts, cricket stumps, horizontal bars for gymnasiums, rowing oars; in fact, any sort of a job where resistance to sudden shock is required. The annual rings can be clearly seen, but the pores and medullary rays are very fine and difficult to see. Ash is sometimes used in furniture work as an imitation of oak. Although it is very tough and strong, in fact, more so than English oak, it has the disadvantage of being too flexible for general use in heavy building work. It also tends to decay and become brittle after a number of years if it is in an exposed position.

Beech.—A large forest tree, very common in the English counties of Sussex, Hampshire and Bucks. The wood is hard and tough, even in grain, and works well. It is sometimes used for furniture making, and can be turned evenly in a lathe. The joiner knows that it is used for tool handles and the stocks of planes. Its chief drawbacks are that it is rather brittle, and although it is very good for use under water, as for sluices, weirs, etc., it rots quickly when subjected to alternate dry and wet conditions. It is also very liable to attack by timber worm and for this reason is not so much used for the making of bookcases, and wardrobes as it used to be. It is strong, tough and durable if kept dry, and is sometimes used for the making of teeth or cogs in gear wheels. It weighs about 45 lb. a cubic foot.

Elm.—A very tough and fibrous wood, which in years gone by was used for piling in difficult ground. Elm was used for the piles under old London Bridge, and when this was pulled down, it was found that the elm which had been under the ground for more than 700 years was in good sound condition. The wood does not easily split, and is remarkably free from cup shakes, star or heart shakes.

The grain is much twisted, and for this reason the wood warps and twists somewhat after being cut. It is difficult to work. Because of its ability to resist the action of water and damp, it has been much used for the making of coffins.

Walnut.—One of the most popular woods for good quality furniture. It is not very strong, and unsuitable for making into heavy beams for supporting floors.

Greenheart.—An extremely strong timber much used in heavy engineering work, grown in the northern part of South America and the West Indies. It is even grained and a dark green in colour.

The wood is exceptionally heavy, weighing between 60 lb. and 70 lb. a cubic foot, which is about twice the weight of ordinary pine or deal. It has enormous crushing strength, and contains an oil which makes it able to resist the attacks of sea worms. It is used in all kinds of marine structures for piles, posts of dock gates, and jetties. Its chief drawback is that it is very apt to split and splinter.

It can be got in sticks as big as 15 in. square and 70 ft. long. Unfortunately, the tree tapers a good deal, so that one often finds a large amount of waney edges in the large size sticks.

Jarrah.—Jarrah is a red Australian timber, sometimes known as Australian mahogany. It is hard, strong and very dense and durable. Like greenheart, it contains an acid which helps it to resist sea worms and ants. It is used on marine work, makes wonderful sleepers on railway tracks, and is a first-class plank for bridge flooring. It does not rot easily when built into masonry or concrete blocks in the ground, and has a long life when used as a telegraph pole. It is rather brittle and liable to cup shakes.

Practically all timbers, except ebony and greenheart, will float in water.

DESTRUCTION AND DECAY

Wood is liable to decay and destruction, either by the action of rotting or the attacks of wood beetles, marine borers and sea worms, or ants. The chief among the destructive sea worms is the toredo. Mr. J. R. Baterden, in his book on timber, says, "The *torredo novalis*, sometimes called ship worm, from its destructive attack on timber ships, is produced by eggs, and is so prolific that the eggs from a single specimen may number a million in one season. They are free swimming in three hours, have a well-developed shell before the end of the day, are very hardy, and nearly all seem to develop to maturity. Its method of operation is to bore by means of its small and beautifully-formed shell. It deposits a thin, calcareous coating on to the newly-cut surface of the wooden tunnel which it makes, forming an enamelled lining through which the animal can glide backwards and forwards."

These nuisances destroy timber quickly, particularly in warm water, so

that timber piles 12 in. one way and 15 in. the other had to be replaced after only six months service in the Gulf of Mexico. In order to protect wood against these sea worms, sheet zinc or copper is sometimes used, tar also seems to be of some use, but the natural protection which greenheart and jarrah possess because of the oil in the tree is the best preservative against the toredo, and for this reason greenheart and jarrah are much used for underwater construction.

Dry rot is caused by the confinement of warm air and stagnant gases around timber. The fungus which attacks the timber feeds on the wood and gradually reduces it to a powder. Wood which has been properly seasoned is much less likely to suffer from dry rot than un-seasoned timber; in fact, good ventilation and protection from dampness are the best means of preventing dry rot from setting in.

MOISTURE CONTENT

Where the moisture content in timber is less than 18 per cent the fungus becomes inactive, and it is to get this sort of condition that damp courses are put in walls, and that the foundations of houses and buildings often have a concrete slab covering to prevent the moisture which is in the ground rising to the floor beams and boards. Creosotes and other preservatives are used to stop the moisture penetrating below the surface of the wood.

Decomposition of wood cannot possibly be caused by dry air. If there is an absence of air and moisture, wood will be preserved in a perfectly good state for thousands of years. We know, for instance, that there are two sycamore coffins in the British Museum which are still in good condition, although they are probably more than 40 centuries old.

Where foundation piles have been in the ground under a river bed, they have sometimes been removed in a perfectly good condition, hundreds of years after they were driven down.

In some countries there is a kind of ant which is known as the termite or white ant, which does a great deal of damage to both live and dead timber. It is often this insect, and not a worm, which causes the damage to furniture.

In order to preserve woods, coal tar, creosote, sometimes known as creosote oil, is forced into the cells or tubes from which the wood is made. On another page we show a very much magnified view of these hollow tubes, and by thoroughly coating the sides, the wood is preserved against the action of wet and moisture.

Painting creosote on to wood fences or sheds is helpful, but where real long protection is required this surface painting is not enough. In the case of railway sleepers, telegraph poles, or the long timber piles which are used for foundations under buildings or to carry piers and jetties, the creosote must get well into the wood.

There are various means of forcing this creosote in, but we have not the space to describe them here. It is generally considered that for real protection about 10 lb. of creosote per cubic foot of timber should be forced into the wood. For some marine work as much as 15 lb. or 20 lb. may be desirable. In addition to creosote, zinc chloride is used in what is known as the burnetising process. Mercuric chloride and copper sulphate are also used, but there is no doubt that creosoting in one or other of its forms is not only the most widely used but the best preservative for timber.

Timber.—Timber used to be used to a fairly large extent in constructional work, but it has now been largely superseded by steel.

English oak has a tensile strength of from 3 to 9 tons per sq. in.; teak 2 to 7; pitch pine, 2 to 5; beech and ash 2 to 7; and elm 3 to 7. The average strength of timber is very variable, but a mean figure of 4 tons per square inch is often used, when the particular kind of wood concerned is not known with certainty.

Strength of timber to resist crushing varies from 2 to 5 tons per square inch, and a mean of $3\frac{1}{2}$ tons per square inch can be adopted.

ULTIMATE STRESSES IN LB. PER SQUARE INCH

Timber	Modulus of Rupture	Tension	Compression	Shearing		Young's Modulus E
				Across Grain	With Grain	
Northern Pine	6,000	6,500	5,000	5,000	600	1,400,000
Pitch Pine	11,000	6,000	5,000	5,000	700	1,700,000
Spruce	5,000	6,000	5,000	3,000	400	1,200,000
Larch	6,000	9,000	3,000	5,000	900	900,000
Oak	10,000	10,000	7,500	3,000	1,000	1,200,000
Beech	9,000	7,000	9,000	—	700	1,350,000
Ash	12,000	9,000	8,000	—	700	1,600,000
Elm	6,000	8,000	7,000	—	—	700,000
Mahogany (Honduras)	9,000	12,500	7,500	—	—	—
Teak	12,000	15,000	9,000	—	—	1,500,000
Greenheart	12,000	9,000	13,000	—	—	1,100,000

QUESTIONS ON CHAPTER XIX

What are the principal objections to using timber ?

How long does a tree live ?

On what does strength of wood depend ?

What are the three principal defects in timber ?

Name four soft woods and what they are used for.

Name four hard woods and what they are used for.

What causes dry rot ?

How is wood preserved ?

CHAPTER XX

STONE

Stone—Oldest Stones—Igneous Rocks—Metamorphic, Sedimentary or Aqueous Rocks—Quartz—Felspar—Tracing History in Stone—Roman Stone in London—Blarney Stone—Dakota Memorial in Granite—Protecting Stone.

BUILDING WITH STONE

IT seems that all through history, stone, bricks and timber have been used as building materials. In modern times, steel and concrete have come into general use as building materials, and glass is today playing an increasingly important part. We can, therefore, say that there are only about five or six kinds of building materials which have come into general use during all the centuries which have elapsed since primitive man started building.

The geologist who studies the formations of rocks and stones divides them into three general classes :

(a) The igneous rocks which were formed by heat ; probably the solidification of the molten material from volcanoes.

(b) The sedimentary or aqueous rocks or stones. An idea of this formation can be got from the word "sediment"—deposited through water.

(c) Rocks, known as metamorphic. These have been subjected to great heat or pressure, maybe both, and this has been sufficient to crush and cause alteration in the form or make-up of the stone. This accounts for the structure and colour of marble.

Expert geologists are generally of the opinion that this earth is mostly hollow with a crust not more than about 10 miles in thickness. All the rocks, shales and stones which are available to man are contained in this relatively thin crust. We have no exact means of knowing when these various stones were formed, but there is considerable evidence available that most of the stones were formed, not a matter of a few thousand years ago, but many hundreds of thousands of years ago ; in fact, it is extremely probable that millions of years have rolled by since the fiery molten materials from volcanoes cooled into the igneous stones.

Builders and engineers use stones for constructing dividing walls, retaining walls, dams, piers, buildings and bridge supports. The principal characteristics

which stones should possess for these purposes are—durability, weight, grain fineness, resistance to compression, resistance to weather ; and they should not be very porous. Some of the more common stones in general use will be considered from these points of view. (*Plate 19.*)

OLDEST STONES

It is generally assumed that the granite rocks are the oldest of the most durable stones. They are particularly hard and difficult to work, and for that reason their use is limited. Granites are composed of quartz, felspar, mica and hornblende.

Quartz is an exceedingly hard material, practically indestructible ; it is not soluble in water and is not attacked by sulphuric acid. It forms into crystals, sometimes looking like a dull glass, but certain crystals are coloured. They may be grey, pink, red, brown and even yellow.

Felspar is a mixture of silicates of aluminium which contain soda, potash and lime.

Felspar generally occurs in rocks of igneous formation ; the crystals are sometimes transparent like a dull glass, sometimes they have a grain, sometimes a red shade, and frequently they are not transparent at all. Felspar is not so hard as quartz, and although felspar does not dissolve in water, it can sometimes be broken up by hydrochloric acid.

Nearly everybody has seen mica and knows that, because of its cleavage property, it can be separated into very thin sheets of lamina. It is much used in electrical work ; it is not nearly as hard as felspar or quartz, and is formed of silicates of alumina and potassium. There are other crystallised earths in the formations, and sometimes iron and magnesium occur.

It is the presence of hornblende, sometimes found almost colourless, but more often in shades of dark green, which gives the green colour found in granites. Not soluble in water, and able to resist both nitric and sulphuric acid, the hornblende is hard and durable, and is a silicate of lime, magnesium iron and aluminium.

The weight of granite varies between 160 lb. and 180 lb. per square foot. Most of the granite quarried in Great Britain comes from Aberdeen and Cornwall.

A DURABLE GRANITE

Rubislaw Aberdeen granite is a grey, fine-grained stone which contains both white and black mica, and also crystals of felspar and quartz. It is one of the most durable of all granites, takes a high polish, and is much used for build-

THE TEMPLE OF THESEUS
AT ATHENS BUILT OF MARBLE
MORE THAN 2,000 YEARS AGO
STILL STANDS.

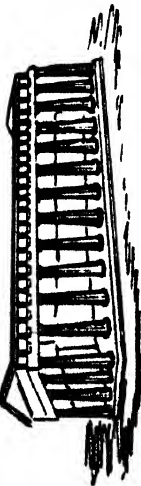

THE MAIN OF ROCKS
FORMATIONS AND
STONES AND
THE RELATIVE POSITION
OF THEIR STRATA
BELOW GROUND.

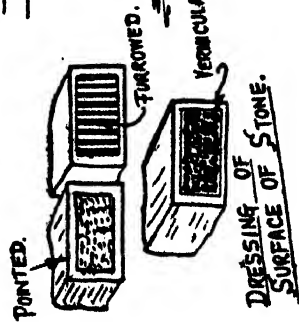
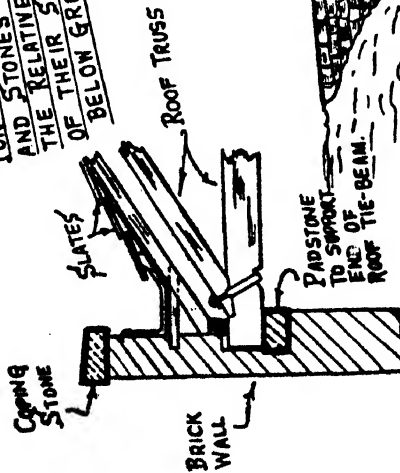
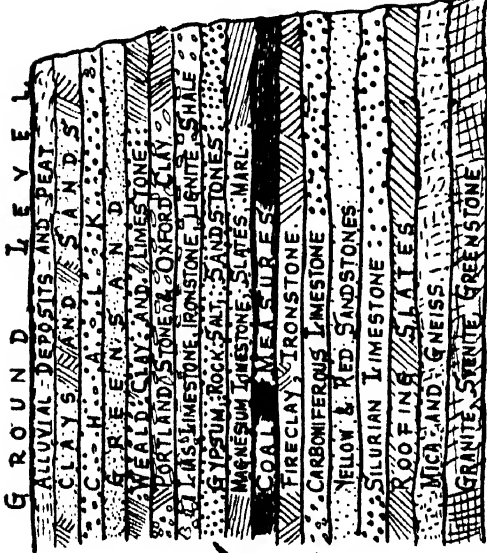

DRESSING OF
SURFACE OF STONE.

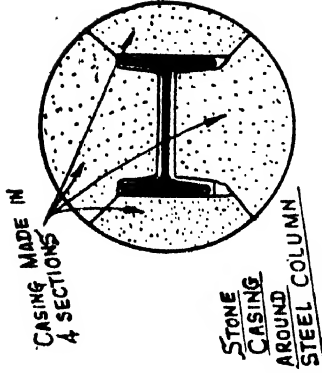

STONE
CASING
AROUND
STEEL COLUMN

STONE ENTABLATURES
AND
SUITABLE FOR ENCASING OVER
A SHOP FRONT.

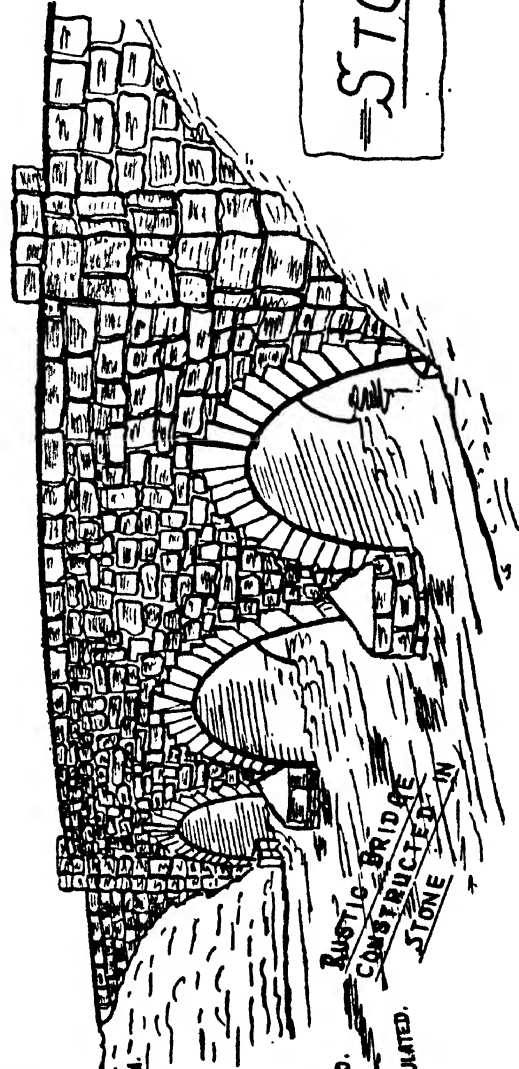
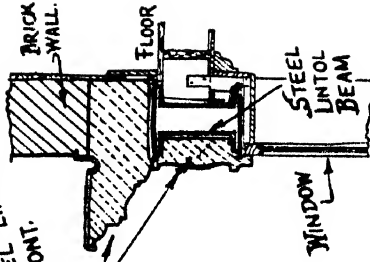

STONE

ing purposes. This granite, like most other granites, is terrifically strong, and it would take a load of 1,100 tons or more per square foot to crush it.

It should be borne in mind that nearly all stones begin to crack or split before half the final crushing load is reached, and for that reason, the safe load to be put on any stone should not be more than about $1/8$ th of the crushing load. In some cases, the actual load carried on stone should not be more than $1/15$ th or even $1/20$ th of the load which would finally crush the stone. This remark holds good not only for any kind of granite, but for any kind of stone used in building or construction work.

Peterhead granite is a coarse reddish-blue colour and like the Rubislaw granite, is found in Aberdeenshire, Scotland. It takes on a very good polish, and is largely used for buildings, civil engineering and monumental work.

Cornish granite is mostly rather coarse in texture and generally grey in colour, but speckled with pinky red crystals. It is a very good granite for general engineering, monumental work, and, like the two Aberdeenshire granites, absorbs very little water.

There are many varieties of limestone, and they are found in many different locations in this country. Their weight, strength, texture and grain are by no means constant. Limestones are sedimentary deposits, probably formed of the millions of small shell creatures which lived in the waters covering the land.

In *Plate 19* a section is shown which gives some idea of the geological periods when the various rock and stone stratas were formed. Although they are shown in the drawing by very nearly horizontal lines, and with each material roughly the same thickness, it is not to be assumed that these various ages were anything like the same length of time.

When a limestone contains 50 per cent or more of magnesium carbonate, it is known as a dolomite, so that a dolomite can really be described as a limestone which is about half carbonate of lime and half carbonate of magnesia.

Ancaster freestone is a good compact creamy-coloured limestone found round the Grantham district. It was used for some of the dressings on St. Pancras station, weighs about 135 lb. a cubic foot, and has a crushing strength of about 190 tons a square foot.

Bath stones are quarried chiefly in Somerset and Wiltshire, and include such varieties as Box Ground, Corsham Down, Combe Down, Farleigh Down, Monks Park. These stones vary in weight. Combe Down is generally about 128 lb. a cubic foot, and is a medium grain, light cream stone. Farleigh Down weighs about 120 lb. a cubic foot, Monks Park 137 lb., Corsham Down around 129 lb., and Box Ground roughly the same. The strength of these limestones is nothing like as great as the granites, and varies between about 90 tons and

140 tons per square foot. Of Bath stones, Box Ground is perhaps the weakest and Monks Park about the strongest.

Portland stone is quarried round the Portland district in Dorset. It is one of the strongest of the limestones, and probably one of the most used for buildings in the London area. It was, in fact, so well known, that when Aspdin invented his cement, he called it Portland cement because it looked like Portland stone. It is a whitish-brown colour, and the Portland Whitbed weighs about 132 lb. a cubic foot, and has an average crushing load of around 200 tons a square foot. The west front of St. Paul's Cathedral, the Horse Guards buildings, and the refacing of Buckingham Palace were all done in Portland stone.

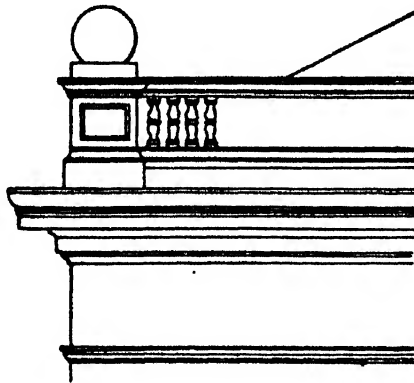

Some of the other limestones are Ketton, Ham Hill, Hopton Wood, and Kentish Rag.

Among the dolomites, the Anston, which is mined near Sheffield, is a cream colour. It is a fine-grained stone, and will take a good arris, and can be prepared to a good surface. Although it is a strong stone, having a crushing resistance of around 300 tons per square foot, there is a great danger of it weathering badly unless it is carefully chosen. The stone does not seem to stand up very well in soot-laden and polluted atmospheres.

HIGH CRUSHING STRENGTH

Red Mansfield is also a dolomite, which has even a higher crushing strength than Anston. Unfortunately, Red Mansfield also does not weather well when used on buildings in large industrial cities.

As the name implies, sandstones are formed of grains of sand or quartz, cemented together by carbonate of lime, iron oxide or clay, which contains alumina and magnesium. Beer stone is quarried near Lyme Regis, in Devonshire, and is a fine-grained and compact stone with a weight of about 130 lb. a cubic foot. Its crushing strength is about 150 tons a square foot; and although

it can be worked to a smooth face, it rubs up chalky. A lot of this stone was used in Exeter Cathedral. In clean country air it stands up well, but is hardly suitable for smoke-laden atmospheres in large cities.

Bramley Fall is mined near Leeds. It is a hard durable stone, but does not take on a smooth surface, and for this reason is not particularly suitable for architectural or ornamental purposes. It is very suitable for heavy engineering structural work, and much used for that purpose.

Craigleith is a Scottish stone found round the Edinburgh district, and is one of the strongest of the sandstones, having a crushing strength of over 800 tons a square foot.

Huddleston stone is distinctly crystalline, and is quarried in Yorkshire. It is a whitish-cream in colour, and was used on many of our historic buildings, such as York Minster and Westminster Hall. It is not a very strong sandstone, having a crushing strength of about 270 tons per square foot.

Another of the well-known sandstones is the red Corsehill stone, which comes from Dumfries. This stone weathers well. The numerous stones collected under the name of York stone quarried in the West Riding of Yorkshire are strong and resist the action of weather very well. Crow Hall and Heworth Burn both come from quarries in the county of Durham. Pennant is a very hard stone quarried in Gloucester, slaty-blue in colour. From Northumberland we get the Heddon and from Gloucestershire the Forest of Dean sandstone.

TRACING HISTORY

The history of a nation can often be traced through its stones, usually in the form of churches, monuments, or walls. The massive piles of stone which our forefathers erected at Stonehenge, on Salisbury Plain, are probably the remains of some druidical circle. The astonishing thing about them is that these stones seem to be of a texture entirely different from any found in the vicinity. This seems to indicate that they were brought from a considerable distance to the site where they were finally erected. Who brought them, how they were brought and who placed these 30 massive upright square pillars which form the outer circle into that particular arrangement still remains an unsolved mystery.

As far back as the Roman invasion into this country, stone was used for building and wall construction. In the wall of a church quite near to Cannon Street Station there is a piece of stone well known to Londoners as "The London Stone." It is interesting to note that in a book made up at the time when Ethelstan was King of the West Saxons, there is a reference to a piece of land which is located as near to the "London Stone."

Every schoolboy knows that it was the custom in the olden days (and, for

that matter, still is), to crown kings on a stone. Several of the early Saxon kings were crowned on a stone which is preserved at Kingston-on-Thames, and protected by stone pillars and iron railings.

The wonderful pyramids of Egypt have picture writings on the walls, and although these pyramids have rested on the Egyptian sands for centuries of time, the meaning of these hieroglyphics baffled students. Now their mystery has been solved, for in 1779, at Rosetta, in Egypt, the French discovered what is now the famous Rosetta Stone, and it was from this stone that the archæologists were able to get the clues which enabled them to solve the mysteries of the pyramids.

In Westminster Abbey, under the Coronation Chair, there is the famous Stone of Destiny which was brought to this country from Scotland by Edward the First.

After a terrible siege by Cromwell's generals, the Irish town of Limerick was forced to capitulate. The signing of this surrender was made over a stone in 1691; the stone can still be seen in Limerick, and is well known as the "Treaty Stone."

Much better known is the stone located in the wall of Blarney Castle, near Cork. Most people have heard of this "Blarney Stone."

There is an interesting granite memorial at North Dakota, U.S.A. Here there are gigantic granite rocks, and for some years scores of men were employed with machines, drills and chisels cutting out four heads of past presidents—those of George Washington, Abraham Lincoln, Jefferson, and Theodore Roosevelt. Some idea of the size and amount of work to be done may be gathered from the fact that it will probably cost £200,000 before the job is finished, and that the forehead of one of these is 200 ft. high. The face, eyes, and mouth have been carefully cut in relation to the features of the president they intend to immortalize. As the rocks are granite, it is not out of the bounds of possibility that civilizations thousands of years hence may gaze on these features just as tourists to Egypt gaze on the Sphinx today.

Marbles are crystalline limestones. The best white marbles, largely used for building decorations and memorial stones, come chiefly from Italy. Greece also exports a good quality white marble. The coloured marbles come from Devon and Cornwall, Ireland, Italy, Greece, Switzerland, Spain, Portugal and Scandinavia. The average weight of marble is about 170 lb. a cubic foot, but sometimes it is as low as 160, and, maybe, as high as 175.

Alabaster is a sulphate of lime, largely used for the bowls of electric lights. Onyx marble, generally known as onyx, is found in France, Mexico, Brazil and North Africa. It is very hard, takes on a wonderful polish, and can be obtained in a variety of colours from which really beautiful ornaments are made.

Although granites are long lasting and some of the sandstones and limestones have resisted the efforts of time for hundreds of years, the destructive action of sulphuric acid in the soots in some of our main cities is certainly making it quite clear that limestones and sandstones show very definite evidence of decay, even within 50 years of being placed in position.

PROTECTING STONE

There are many preservatives for protecting stone, but in most cases the preservative is more apparent than real, as the decay takes place beneath the surface of the protecting skin. This question of stone decay is a very real one, exercising the minds of eminent authorities.

There are many artificial stones now being made and successfully used in building work. It is possible that there will be an increased use of these artificial stones in the future.

QUESTIONS ON CHAPTER XX

What are (1) igneous rocks, (2) sedimentary rocks, (3) metamorphic rocks?

What are the oldest rocks and most durable stones?

What is (1) Quartz, (2) Felspar?

Name five kinds of building stones, and their properties.

What are (1) marble, (2) alabaster?

GLASS

*Glass and Its Uses—Early Coloured Glass—Sound
Insulation—Crown Glass—Resisting Fire.*

It is known that if sand and caustic soda are fused together a homogeneous and transparent material will be formed. How glass was first made we are not sure. Specimens of glass have been found which have been assumed to be from a period of about 2,000 years B.C. In some Egyptian tombs dating back to about that time, paintings have been found representing the art of glass blowing. It is certain that the Egyptians knew how to colour glass. The Chinese seem to have been acquainted with nearly everything at some stage or other of the remote past, and they certainly knew of glass hundreds of years before Julius Cæsar set foot in this country. The Greeks and Romans knew of the art of making glass, and the writer Pliny mentioned that soda was used in the manufacture of Roman glass.

EARLY COLOURED GLASS

The Egyptians coloured glass by mixing metallic oxides such as copper and cobalt into the glass mixture. The Romans produced coloured glass and also patterned glass by melting together glasses of different colours. How long glass has been known in this country can only be surmised. It is certain that glass windows were used early in the seventh century, but only in very rare cases, and that it was probably about the twelfth century before glass-making became really known in Europe. The art of glass-making was practised in England some 500 years ago. Both flint glass and plate glass were invented in English glass works.

Some say the name "glass" comes from the Latin word *glacies* meaning ice, others from the Gallic word *glassum* meaning amber, while some authorities claim the word comes from the Anglo-Saxon *glisnian* meaning to shine.

Glass has been defined as a hard, brittle, transparent, non-crystalline solid, consisting of a mixture of silicates of metals. Roughly, the composition of the different glasses most commonly used is :

Material	Window glass	Plate glass	Flint glass
Silica	70%	76%	50%
Potash	—	17	11
Lime	13	6	—
Soda	13	—	—
Lead oxide	—	—	—
Alumina	4	1	1

The raw materials used for glass making are silica sand, salt cake, soda ash, pulverised limestone, and cullet. (*Plate 20.*) Cullet is broken glass of the same kind as that which it is intended to prepare. The lead which is used in glass making is often in the form of red lead. The lead in the glass makes it bright and shiny. Although the art of manufacturing glass has been known for so long it is only within the present century that glass has come into its own, for modern research has made this almost a glass age.

Today glass can be made which has properties undreamed of 25 years ago. We said in our definition that glass was a hard, brittle substance. And yet today glass has been made which can be twisted and bent, which is so soft that nails can be knocked through, and which can even be planed like wood.

Every motorist knows the advantages of safety glass. Thicker glass made in the same way as the motor-car safety glass will resist bullets and hammer blows, and is therefore suitable for protecting bank buildings against the attacks of gangsters and armed criminals.

In a building erected in the U.S.A. in 1936 the framing is made with steel columns and the sides are glass bricks. Instead of using windows for light, long continuous blocks of these glass bricks were used. One wall of the building is 540 ft. long, and there are horizontal panels each 60 ft. long and 8 ft. 6 in. high. The architectural effect is really good, and whilst there is an extraordinary amount of daylight coming into the building through these glass bricks, the faces are irregular and therefore break up the glare which would be a terrific nuisance if ordinary window glass was used. All the glass blocks are laid in cement mortar richer than that generally used for brickwork.

SOUND INSULATION

Glass can also be made into a fluffy material known as glasswool, and this has very good acoustical and insulating properties.

Every housewife today knows that fireproof, heat-resisting glass can be safely placed in a hot oven.

Glass tubes and pipes are used in many industries, and have the advantage not only of being able to resist acids and other corrosive materials, but of being free from germ contamination; also they can be kept spotlessly clean. There is the further advantage that it is possible to make a glass pipe which can be scalded out with steam and which will not shatter.

In these days we can buy an electric light bulb quite cheaply, but this would have been impossible 35 years ago. Today when electric light bulbs are used by the million they are made on machines which turn out between 300 and 400 bulbs a minute. One such machine uses up more than 40 tons of glass in a single day.

In some buildings, panes of glass can be seen which have a sort of blob or bull's-eye in them. In years gone by this Crown glass, as it is called, was probably the most commonly used of any for windows. At the end of a blowpipe a mass of about 10 lb. of molten glass is collected from the furnace. By blowing down the pipe, the molten glass is thinned out somewhat, and the pipe is then revolved rapidly so that the glass spreads out into the form of a sheet by the action of centrifugal force. The disc is of fairly uniform thickness, except at the centre where it is attached to the blowpipe, and here a thickened lump or bull's-eye boss is formed.

CROWN GLASS

This Crown glass bull's-eye in a window admits light into a place, but does not make for clear vision. As a means of attracting attention and novelty it is sometimes used in special buildings, such as hotels, restaurants, and in modern houses built to represent Tudor construction.

The large glass used in some modern shop windows is plate or cast glass. The stages through which a plate-glass passes are : casting, grinding, and polishing. During the casting stage the melted glass from the furnace is tipped on to a flat iron table. Iron rollers are then moved over it so that it is flattened and reduced to an even and desired thickness. In some modern plants the molten glass from the furnace is drawn off in a continuous stream and passes through rollers on to a continuous conveyor, where it gradually cools.

Whichever system is used, it is necessary to grind and smooth the plates before they are ready for polishing. During this grinding operation the plate is much reduced in thickness. For instance, a plate which is passed through rollers so that it is 1 in. thick before grinding, might be reduced to $\frac{5}{8}$ in. thick after grinding. Grinding is done between two cast-iron plates, and between the plates and the glass there is powdered emery or sand flushed with water. After the plate has been ground smooth on both sides it is then ready for polishing by rubbers. Plate glass is generally not less than $\frac{3}{16}$ in. thick, and can be made more than 1 in. thick.

Ordinary house window panes are made of sheet glass. It can be either fluted, plain or corrugated. It is bought and sold by weight and not by thickness, although of course the weight determines the thickness. Thus we talk of a 15 oz. glass, a 21 oz. glass, 26 oz., 32 oz., 36 oz., and 42 oz. The weight is the weight for one square foot.

A year or two ago one of the best known American firms of glass makers succeeded in producing a glass reflector required for an astronomical telescope, the weight of this single piece of glass being 20 tons. Extraordinary skill was required to melt and pour into a single mould the glass to make this lens. It

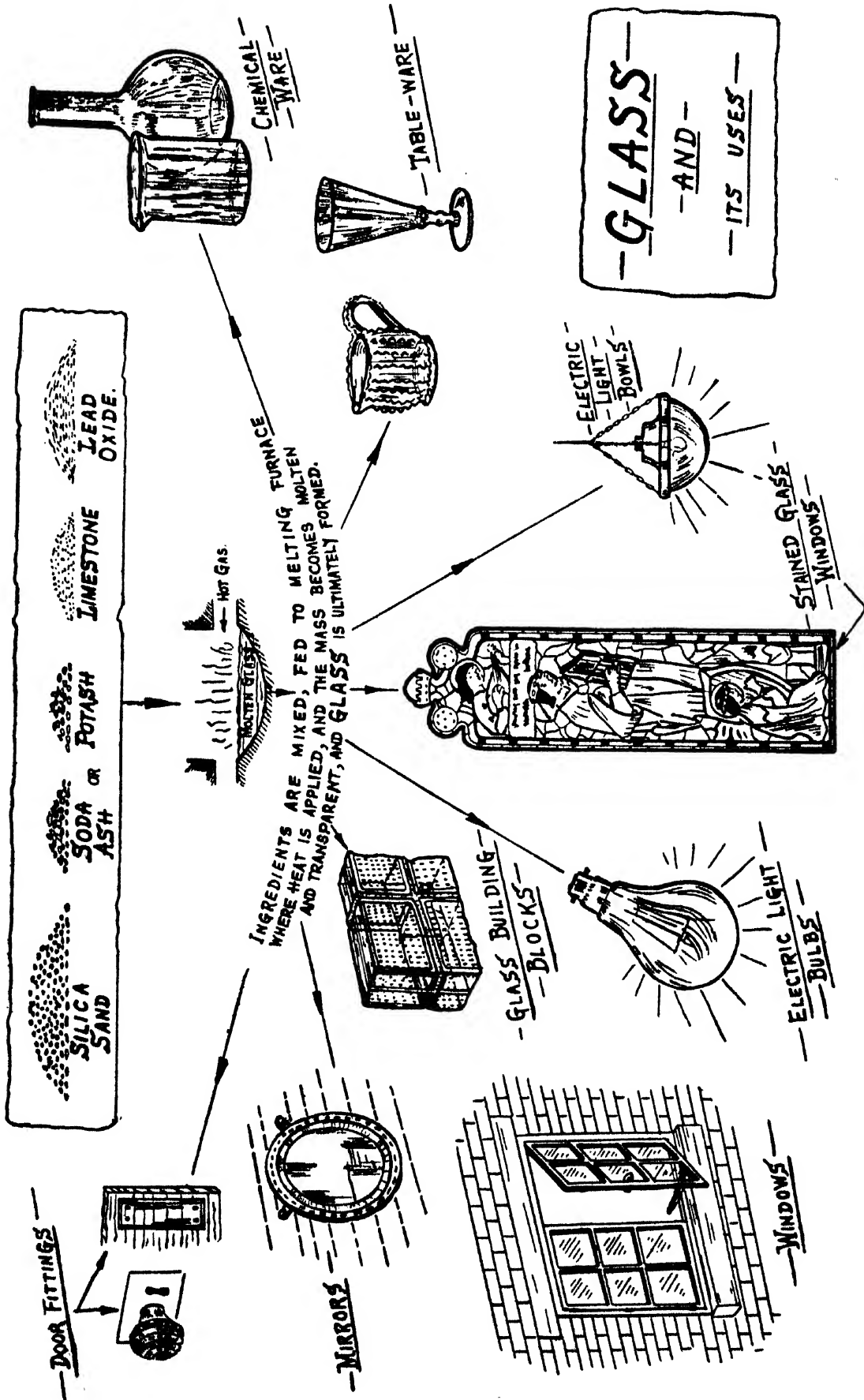

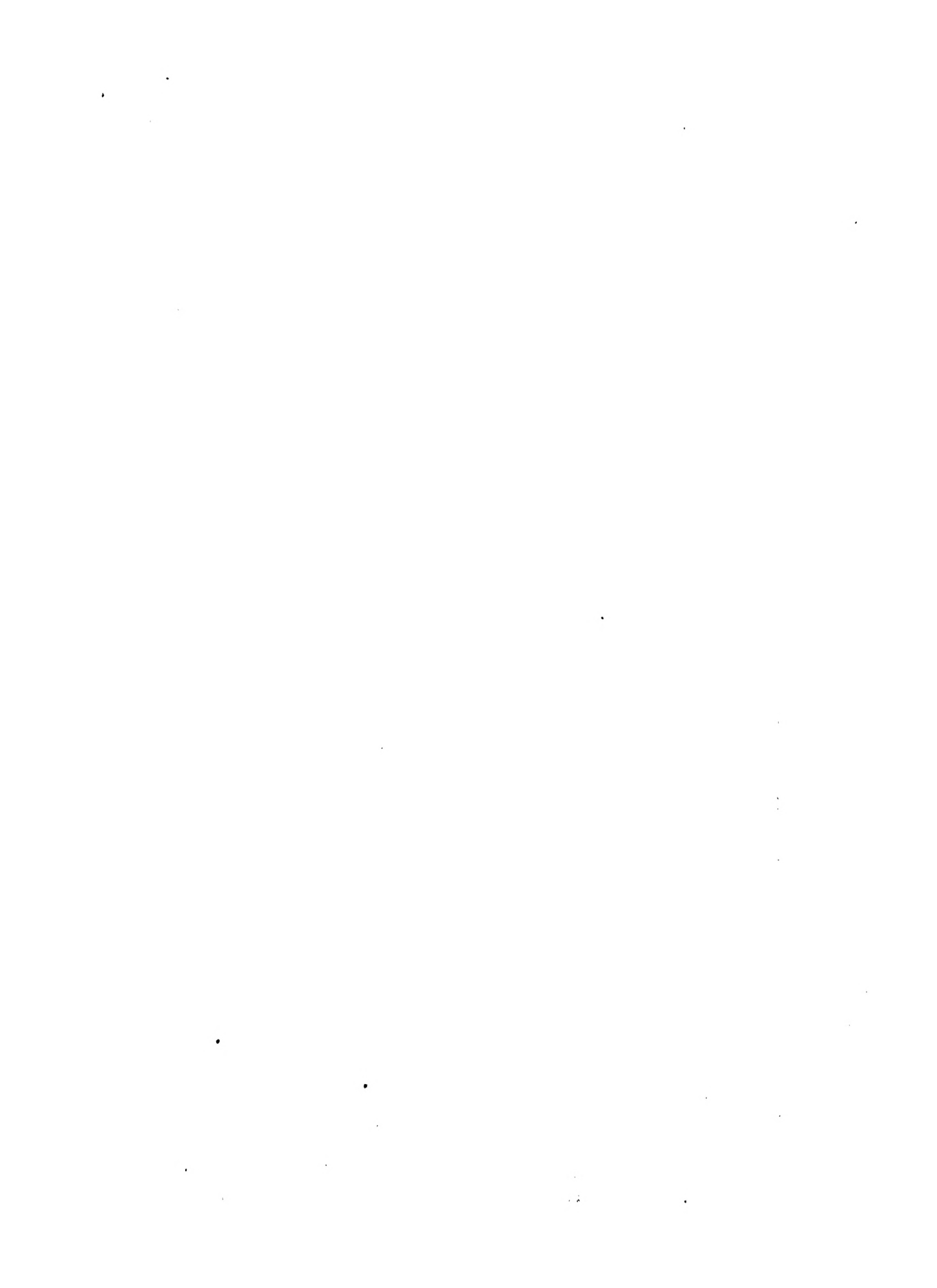

was not like pouring concrete, some one day and some the next, for it was necessary to get this one piece with no joints and no cracks.

Of another kind, but no less wonderful work, is the coloured glass in some of the Cathedrals in this country, and abroad. This is more specially so when we think that some of this glass was made before the grandfathers of the present generation were born.

From cathedral windows to glass for air raid shelters is a long distance, yet experiments with special glass as a means of resisting weight and shock have proved so successful that it was proposed to use glass to reinforce concrete slabs for the sides of air raid shelters.

RESISTING FIRE

It will be realised that there is a remarkable similarity between glass and a fire-resisting silica brick. In both cases the hardness is produced by the silica, and the reason why the glass is transparent is because of the addition of potash or soda. The firebrick, which might contain the same amount of silica as glass, is not transparent because it does not contain this soda or potash.

Glass varies in weight, but generally is about two and a half times as heavy as water, so that one cubic foot of glass weights roughly 160 lb. Plate glass is somewhat heavier, and may be as much as 170 lb. a cubic foot. Compared with this, ordinary drinking water weighs about $62\frac{1}{2}$ lb. a cubic foot, and a gallon of eight pints weighs almost exactly 10 lb. Builders sometimes use glass to hold liquids other than water, so here's health !

QUESTIONS ON CHAPTER XXI

What materials are used for glass making ?

Did the early Egyptians have coloured glass ?

What is brown glass ?

Why is lead used for glass making ?

INDEX

- ACID STEEL, 38**
Aggregate, 107
Alumina, 14, 93, 97
Aluminium, 86, 104
Annealing, 23
Arches, 55
Ash, 148
- BASIC STEEL, 37**
Beams, 61
Beech, 148
Bending Moments, 59
Bessemer, 31
Birch, 148
Blast Furnace, 7
Blister Copper, 77
Blooms, 27
Blow Holes, 22
Bond, 111
Bosh, 7
Brass, 77
Bressummers, 55
Bricks, 124
Bronze, 77
- CALCIUM, 14**
Carbon, 14, 17, 32
Castings, 16
Cast Iron, 16, 42
Cement, 93
Chalk, 98
Charcoal, 14
Chilled Iron, 23
Clay, 98, 125
Clinker, 94
Coal, 133
Coke, 14
Columns, 21
Concrete, 67, 107
Converter, 31, 72
Copper, 71
Corrugated Sheets, 84
Crown Glass, 164
Crushers, 94
Cupola, 14, 17
- Deal, 146**
Drain Pipes, 14
Dry Rot, 150
Dulong's Formula, 136
- Earths For Bricks, 125**
Elasticity, 47
Elastic Limit, 47
- Electrolytic Copper, 76
Elm, 148
- FELSPAR, 154**
Felt, 104
Ferrous Metals, 2
Fibre Glass, 103
Fir, 147
Fire Bricks, 129
Flettons, 126
Flitched Beams, 55
Floors, 149
Flux, 7
Forge, 1
Foundations, 150
Fuel, 8, 135
- GANGUE, 8**
Gas, 13
Geological Ages, 153
Glass, 163
Granite, 154
Graphite, 17
Gravel, 93
Greenheart, 149
Grey Iron, 16
Gypsum, 94, 121
- HEMATITE, 2**
High Alumina Cement, 97
- INSULATION, 103, 163**
Iron, Cast, 16
Chilled, 16
Grey, 16
Malleable, 17, 23
Mottled, 16
Pig, 14, 16
White, 16
Wrought, 24
Iron Ores, 2
- JOISTS, 61**
- KILNS, 94**
Knots, 147
- LEAD, 79, 84**
Lead Oxide, 79
Lignite, 135
Lime, 116, 121
Limestone, 10
Lining, 24, 32, 129
Lintols, 55
- MALLEABLE IRON, 17, 23**
Manganese, 42
- Mix of Concrete, 107
Moisture, 150
Mortar, 121, 122
- NICKEL, 85**
Non Ferrous Metals, 79
- OAK, 147, 151**
Oxides, 2
Oxygen, 3
Oyster Shells, 17
- PEAT, 134**
Perspex, 106
Plaster of Paris, 121, 124
Plasters, 116
Portland Cement, 98
Puddling Furnace, 24
- QUARTZ, 154**
- RAPID HARDENING CEMENT,**
Reinforced Concrete, 107
Reverberatory Furnaces, 24
Rolled Steel Beams, 66
Round Bars, Area of, 114
- SEGAR CONES, 131**
Soft Wood, 145
Solder, 83
Stainless Steel, 41
Steel, Bessemer, 30
Classification, 31, 43
Hard, 31
Medium, 31
Open Hearth, 37
Soft, 31
Steel Beams, Rolled, 61
Stones, 153
Strain, 47
Stress, 47
Sulphur, 22
- TEAK, 129**
Tension, 57, 108
Terra Cotta, 105
Timber, 141
Tin, 87
Tube Mill, 94
Tungsten, 41
- WALL LOADS, 56**
Wood, 141
Wood Wool, 101
Wrought Iron, 24
- ZINC, 77, 84**

