

**BIRLA CENTRAL LIBRARY**

PILANI [ RAJASTHAN ]

Class No. 621.8

Book No. B966 M54

Accession No. 43420





*Machine Tool Operation*

**PART II**

## MACHINE TOOL OPERATION

PART I CONTAINS THE FOLLOWING DIVISIONS:

<i>Safety</i>	<i>The Drill Press</i>
<i>Measuring Tools</i>	<i>The Lathe</i>
<i>Bench Work</i>	<i>Forge Work</i>

PART II CONTAINS THE FOLLOWING DIVISIONS:

<i>The Shaper</i>	<i>Hydraulics</i>
<i>The Planer</i>	<i>Metal Band Saws</i>
<i>The Milling Machine</i>	<i>Metallurgy</i>
<i>The Grinding Machine</i>	<i>Cutting Fluids</i>

# *MACHINE TOOL OPERATION*

## **P A R T II**

The Shaper • The Planer • The Milling Machine  
The Grinding Machine • Hydraulics  
Metal Band Saws • Metallurgy • Cutting Fluids

**BY Henry D. Burghardt**

**AND Aaron Axelrod, ED.D.**

*With the assistance of James Anderson*

**T H I R D E D I T I O N**

**McGRAW-HILL BOOK COMPANY, INC.**

*New York Toronto London*

*The Authors*

**HENRY D. BURGHARDT**

Late Head of Machine Shops, Wm. L. Dickinson High School, Jersey City, New Jersey; Author of *Manual for Machinists*, War Department Committee on Education and Special Training

**AARON AXELROD, Ed.D.**

Instructor of Machine-shop Science and Mathematics, Vocational and Technical High School, Bayonne, New Jersey; Formerly Instructor of Applied Science and Mathematics, School of Education, New York University, New York; Author of *Machine Shop Mathematics* and Coauthor of *Introductory Shopwork*

With the assistance of JAMES ANDERSON of the Queens Vocational High School, New York

Machine Tool ~~Operation~~, Part II

Copyright, 1954, by the McGraw-Hill Book Company, Inc.

Copyright, 1922, 1937, by the McGraw-Hill Book Company, Inc. Printed in the United States of America. All rights reserved. This book, or parts thereof, may not be reproduced in any form without permission of the publishers.

*Library of Congress Catalog Card Number: 53-8390*

# Preface

The preface of Part I gives the reasons for preparing this text. Part I deals with Safety, Measuring Tools, Bench Work, The Drill Press, The Lathe, and Forge Work. An attempt has been made in this volume (Part II) to organize the *fundamental principles of construction and operation* of the shaper, planer, milling machine, grinders, and band saws. Chapters embodying what every machinist should know concerning spur gears and bevel gears are included.

Only fundamentally has this work anything to do with production. Special rapid-production machines and tools represent various combinations of fundamental mechanisms, methods, and processes. The purpose of this text is to discuss these fundamentals and build a foundation for rapid production, the same sort of foundation that arithmetic builds for mathematical calculations.

The chapters on metallurgy and hydraulics have been greatly expanded to include the most modern machine tools which operate under hydraulic power. A new chapter on cutting fluids has been added, because a knowledge of this information is very vital today in modern machine-shop practice. Another new chapter is on metal-cutting band saws. This tool is now almost universally used in production shops as well as in vocational and technical high-school shops. Because of the increase in the use of cams in machine-tool operation, material has been added on cam milling.

Perhaps a statement regarding the way in which the following text is presented and the reasons therefor should be made here:

*First:* While there are a great many sizes, types, and kinds of each of the standard machine tools, and while the makers differ in details of design, the fact remains that the primary function, and the basic principles of construction and operation of the given class of machine, are the same, regardless of the size or of where it is made. Therefore, a well-known example of each of the machine tools under discussion has been selected and described, and typical mechanisms illustrated and explained in such a way as to bring out the general details.



*Second:* The operator's production, interest, and progress are in proportion to his understanding of the basic principles of the construction of the machine he is running—the special mechanical features, feed changes, speed changes, and adjustments of the machine. Consequently, these things have been discussed early in the study of the particular machine.

*Third:* The broader the student's knowledge concerning the cutting tools used in the given machine, and the more quickly he gets a fairly comprehensive idea of the shapes, sizes, and characteristics of these tools, the easier and better he can "run the machine." Therefore, the cutting tools used have been explained in considerable detail.

*Fourth:* It is well worth while to look up or reason out correct answers to questions concerning a subject in which one is interested; it not only adds that bit of information to the store of facts one has but makes for progress. Several hundred questions appear in the book as an incentive.

*Fifth:* Information concerning operations and methods, or suggestions concerning typical setups may be expected from a text, and brief instructions regarding the job at hand may be obtained from the foreman or the instructor. However, the student must understand that if he hopes to succeed, he must use his own reasoning powers and develop his resourcefulness. Hence, principles have been discussed and unnecessary details omitted.

Many concrete examples of specific operations have been given in order that the apprentice or the student will be able to learn the *correct* method of doing and setting up the particular job. This lends itself for positive learning.

It is hoped that these pages will prove helpful to the young man beginning his work on the various machines; that the text is clear, comprehensive, and interesting enough for the reader to enjoy studying it; also, that the descriptions and illustrations, the suggestions and the questions, will stimulate the student to seek further information contained in numerous treatises on machine tools.

The following factory representatives have cooperated in a large measure in the writing of this text and deserve our sincere thanks: T. F. Gray, Assistant Sales Promotion Manager, The Carborundum Company; J. J. Murphy and A. G. Baumgartner, The Cincinnati

Shaper Company; Doris Keene, The DoAll Company; W. Grindrod and H. J. Dods, The Cincinnati Milling Machine Company; L. Goff and A. W. Bartlett, The Brown & Sharpe Manufacturing Company; Franklin Kahle, The G. A. Gray Company; E. B. Knowlton, The Norton Company; J. A. Abbott, The Shell Oil Company; Carl G. Nordmark, The L. S. Starrett Company; H. W. Franke, Kearney & Trecker Corporation; and R. B. Purdy, The Socony-Vacuum Oil Company.

The following have read the manuscript and to them we owe our gratitude and thanks for the suggestions offered: Oliver C. Wade-man, Curtiss-Wright Corporation, Training Division, Wood-Ridge, N.J.; F. D. Manganelli, Asst. Director, Hartford Regional Technical School, Hartford, Conn.; Joseph I. Salzman, Instructor, Vocational & Technical High School, Bayonne, N.J.; and H. O. Linsley, Associate Editor, American Machinist, New York, N.Y.

Mr. James Anderson, Queens Vocational High School, Long Island City, N.Y., has revised Chapters 8, 9, and 10, and to him our many thanks.

Finally, Mrs. Edith R. Axelrod has spent days and nights typing the manuscript, and to her, our humble gratitude.

AARON AXELROD, Ed.D.



# Contents

## PREFACE

v

## THE SHAPER

### 1. SHAPER CONSTRUCTION

1

The Value of the Shaper	Power Rapid Traverse
Parts of the Shaper	Feed
Reasons for Gib Adjustments	Worktables
Lubricating the Shaper	Tool Head
Operation of the Shaper	Vertical and Angular Downfeed
Other Construction Details	The Hydraulic Shaper

### 2. SHAPER WORK

25

Shaper Cutting Tools	To Sharpen a Square-nose Tool for Finishing Cast Iron
Shaping with Carbide Tools	Setting the Head for Vertical and Angular Cuts
Right-hand and Left-hand Tools	Shaping Vertical or Angular Surfaces
Toolholders	To Shape a Rectangular Block or Similar Piece Square and Parallel
Speeds and Feeds	Shaping an Irregular Cut
Holding the Work	Shaping Tongue and Groove
Clamping Work to the Table	Shaping Slots, Keyways, etc.
Causes for Inaccurate Work	Shaping Dovetails
Inaccurate Vise or Vise Settings	Measuring Dovetails
Chips and Burrs as a Cause for Inaccurate Work	The Vertical Shaper
Preliminary Hints on Shaper Work	
How to Adjust the Length of Stroke	
The Horizontal Cut	

## THE PLANER

### 3. PLANER CONSTRUCTION

81

Parts of the Planer	The Planer Platen
Size of the Planer	The Crossrail
Openside Planer	The Tool Head
Modern Planers	Quiet-running Qualities of the Planer
Units of Planer Construction	Planer Feeds and Speeds
The Planer Bed	Safety Precautions for the Planer

**4. PLANER WORK**

93

Methods of Holding Work  
Clamping Accessories  
Principle of Clamping  
Clamping Hints  
Leveling  
Laying Out  
Measuring and Gaging  
Planer Cutting Tools  
Setting the Tool

Cutting Speed, Depth of Cut, and Feed  
Starting the Cut  
General Precautions  
Typical Planer Job  
Similarity of Shaper and Planer Work  
Planing T Slots  
Use of Tool Lifter

**THE MILLING MACHINE****5. MILLING-MACHINE CONSTRUCTION**

127

Types of Milling Machines  
Milling Machines Having Vertical Adjustment of Worktable  
The Universal Milling Machine  
The Plain Milling Machine  
The Vertical-spindle Milling Machine  
Parts of the Brown & Sharpe Universal Milling Machine  
Attachments for the Milling Machine  
The Index Centers  
The Raising Block  
The Tilting Table  
The Vertical-spindle Milling Attachment  
The Universal Milling Attachment  
The Slotting Attachment  
The Circular Milling or Rotary Attachment  
The High-speed Milling Attachment

The Rack Milling Attachment  
The Vertical Milling Machine  
Typical Operations on the Vertical Milling Machine  
Safety on the Milling Machine  
The Jig Borer  
Parts of the Jig Borer  
Inserting Shanks in the Spindle of the Machine  
Setting Up the Work  
Making Settings  
Locating the Position of Work on the Table with Respect to the Table Coordinates  
Suggested Order of Operations  
Drilling and Boring  
The Rotary Table  
The Jig Grinder

**6. MILLING CUTTERS AND THEIR HOLDING DEVICES**

170

Milling Cutters and Milling  
Classification of Milling Operations  
Common Milling Operations  
Milling Cutters  
Kinds of Milling Cutters  
Milling-cutter Materials  
Right-hand and Left-hand Cutters  
Advantages of Coarse Teeth  
Sharpening Cutters

Holding the Cutter  
The Standardized Spindle End  
Milling-machine Arbors  
The Collet for Taper-shank Mills  
The Brown & Sharpe Cam Lock  
Holding Straight-shank Cutters  
Holding Face-milling Cutters  
Screw-on Cutters and Arbors

## CONTENTS

*xi*

### 7. SPEEDS, FEED, AND DEPTH OF CUT

206

Cutting Speed	Analysis of Cutting-feed Conditions
Cutting-speed Calculations	The Depth of Cut
Milling-machine Feeds	The Finishing Cut
Definition of Feed	Lubricating the Cutter
Conditions Governing the Amount of Feed	Direction of Cutter and Feed

### 8. TYPICAL MILLING SETUPS AND SIMPLE OPERATIONS

214

Clamping Work to the Table	How to Mount the Milling Cutter
Holding Work in a Vise	Setting the Speed and Feed
The Plain Vise	Setting the Feed Trip
The Flanged Vise	Use of the Positive Stop
The Swivel Vise	The Unwanted Undercut
The Cam-action Vise	Examples of Plain Milling Operations
The Toolmakers' Universal Vise	Milling a Rectangular Piece
Milling-machine Fixtures	Squaring the Ends
Setting Up the Milling Machine	Boring and Drilling
Accurate Mounting of Work-holding Devices	Simple Graduating
Methods of Alignment	Face Milling
Special Vise Jaws Used as a Fixture	Cutting a Keyway or Similar Groove
The Milling-machine Setup	Locating the Cutter Central
Introduction	Adjusting for Depth of Cut
Setting Up the Job	"Woodruff" Keys

### 9. THE INDEX HEAD AND INDEXING OPERATIONS

250

The Index Head	Typical Indexing Operations
The Gear-cutting Attachment	Milling a Square or a Hexagon
The Spiral-milling Head	Straddle Milling
The Universal Spiral-milling Head	Holding Work for Drilling
Methods of Indexing	The Index Head Used for Rotary Milling
Direct Indexing	Fluting Reamers, Taps, etc.,
Simple Indexing	The Cut-and-try Method
Angular Indexing or Indexing in Degrees	The Layout Method
Graduating with the Index Head	Unequal Spacing or Increment Cut
The Wide-range Divider	Boring in the Milling Machine

**10. HELICAL OR SPIRAL MILLING** 303

The Spiral or Helix	Short- and Long-lead Attachment
The Lead of the Spiral	To Use the Card Furnished with the
Five Features of Spiral Milling	Machine
The Gears Necessary for Spiral Milling	The Operations of Cutting a Spiral
Spiral-head Gearing	The Spiral-milling Cutter
The Index Head with Bevel Gears	Reasons for Double-angle Cutters
The Index Head with Spiral Gears	Setting the Cutter for Spiral Milling
Change Gears for Spiral Milling	The Operation of Setting a Double-
Calculating the Gears for Spiral Milling	angle Cutter
The Angle of the Helix or Spiral	A Typical Spiral-milling Job
Milling Steep Spirals	Cam Milling
	The Machine Setup for Milling a Cam
	The Rotary Table

**11. SPUR GEARS AND BEVEL GEARS** 343

Definition of a Gear	The 20-deg. Stub Tooth
Common Gear Types and Their Uses	Values Not Standard
Methods of Cutting Gears	Metric Gears
Spur Gears	Bevel Gears
Reasons for Gears	Pitch Cylinders, Pitch Cones, Spur
The Pitch Circle or "Pitch Line"	Gears and Bevel Gears
Tooth Parts	Laying Out Bevel Gears, Shafts at
The Module	Right Angles
Gear Nomenclature	Laying Out Bevel Gears, Shafts Not
Definitions and Rules, Spur-gear	at Right Angles
Elements and Tooth Parts	Calculations for Bevel Gears
Rules and Formulas for Dimensions	Definitions and Rules, Bevel-gear
of Spur Gears	Elements and Tooth Parts
Shape of a Gear Tooth	Example Showing Calculations for
The Base Circle and Pressure Angle	Miter Gear
Gear Cutters	Cutting a Bevel Gear in a Milling
Full Depth 14½-deg. and 20-deg.	Machine
Involute Gears	Gear-generating Methods

**THE GRINDING MACHINE****12. GRINDING-MACHINE CONSTRUCTION** 393

The Grinder in Mass Production	Setup Adjustments and Controls of the
Types of Grinders	Brown & Sharpe Universal Grinder
Cylindrical Grinders	Plunge-cut Grinders
Roll Grinders	Ordinary Plunge-cut Grinders
Piston Grinders	Crankpin Grinders
Universal Grinders	Camshaft Grinders

## CONTENTS

*xiii*

Thread Grinders  
Gear Grinders  
Internal Grinders

Surface Grinders  
The Tool-and-cutter Grinder  
Definition of Grinding Terms

### 13. GRINDING WHEELS

426

The Abrasive Tools of the Machine Shop  
Component Elements of a Grinding Wheel  
Abrasive Grains  
Bonds  
Grade  
Structure  
Standard Grinding-wheel Shapes  
Mounted Wheels  
Operations in Making the Wheel  
Cut-off Wheels

Wet Cutting  
Low and High Speeds  
Factors in the Selection of Grinding Wheels  
Standard Wheel Markings  
Examples of Wheel Specifications  
Recommended Wheel Speeds in Surface Feed per Minute  
Handling, Storage, and Inspection  
Diamonds and Diamond Wheels  
Wheels for Grinding Carbide Tools

### 14. GRINDING PRINCIPLES AND PRACTICE

456

Safety on the Grinder  
Kinds of Grinding  
Factors in Successful Grinding  
Arc and Area of Contact  
Mounting the Wheel  
Truing and Dressing a Grinding Wheel  
Types of Wheel Dressers  
The Diamond Dressing Tool  
Grinding Practice  
Setting the Work  
Setting the Wheel Speed  
Setting the Work Speed  
Setting the Table Speed  
Setting the Depth of Cut  
Causes of Inaccurate Work and Imperfect Appearance  
Causes of Wheel Wearing Too Rapidly  
Causes of Wheel "Glazing"

Causes of Wheel Loading  
The Advantages of Using Dead Centers in Grinding  
The Use of Back Rests or Steady Rests  
Roughing and Finishing Cuts  
The Use of Cutting Lubricants in Grinding  
Grinding Operations  
A Few Suggestions  
Cylindrical Grinding  
Shoulder Grinding  
External Taper Grinding  
Internal Grinding  
Face Grinding  
Cutter Sharpening  
Surface Grinding  
The Centerless Grinder  
Features of Centerless Grinding  
Laps and Lapping

## HYDRAULICS

### 15. HYDRAULIC POWER TRANSMISSION

503

Advantages of Hydraulic Transmission

Hydraulic Principles  
Elements of Hydraulic Systems



Driven Units	Automatic Control
Cross-fed Mechanism	Hydraulic Oil Requirements
A 35-ton Hydraulic Press	Some Modern Hydraulic Machine
Rapid-traverse and Feed Circuit	Tools

**METAL BAND SAWS**

<b>16. METAL-CUTTING BAND SAWS</b>	<b>544</b>
Band-tool Terminology	Table Feeds
Technique of Using Blades	Coolant and Lubricant Agents
Friction Cutting or Sawing	Typical Operations on the Metal
Setting Up the Band Tool	Band Saw
The DoAll Contour-matic Sawing	Some Operations on the Metal Band
Machine	Saw
Operating Speeds	

**METALLURGY**

<b>17. METALLURGY, PROPERTIES, AND USES OF FERROUS METALS AND ALLOYS</b>	<b>565</b>
Definition and Scope	The Open-hearth Process
Atoms and Their Behavior	The Bessemer Process
Properties of Metals	The Electric Process
Definitions of Properties of Metals—	Chemical Nature of Steel
Types of Metals	Carbon in Steel
The Production of Iron and Steel	Manganese in Steel
Iron Ores	Silicon in Steel
Mining of Iron Ores	Phosphorus in Steel
Refining of Iron Ores	Sulfur in Steel
The Blast Furnace	Alloy Steels
Cast Iron	The S.A.E. Numbering System
How Castings Are Made	Effects of the Alloying Elements
Steelmaking Processes	High-speed Steel

<b>18. METALLURGY, PROPERTIES, AND USES OF NONFERROUS METALS AND ALLOYS</b>	<b>601</b>
Copper	Manganese Bronze
Tin	Tobin Bronze
Zinc	Naval Bronze
Lead	Brass
Aluminum	Babbitt
Bronze	Monel Metal
Bearing Bronze	Duralumin
Phosphor Bronze	

## CONTENTS

*xv*

### 19. HEAT-TREATMENT OF STEEL

611

Normalizing	Tempering Experiment
Annealing	Hints on Tempering
Hardening and Tempering	High-speed Steel
Theory	Testing the Hardness of Steel
Machine Steel and Carbon Tool Steel	Cas-hardening and Pack Hardening
The Hardening Heat	Terms Relating to Heat-treatment
Metcalf's Experiment	Operations
Hints on Hardening	

### CUTTING FLUIDS

#### 20. CUTTING FLUIDS

627

Desired Characteristics in Cutting	Heat of Friction
Fluids	Types of Cutting Fluids
Sources of Heat Due to Metal Cutting	Functions of Cutting Fluids
Heat of Deformation	Classifying Cutting Oils
Heat of Chip Distortion	Choosing the Correct Cutting Fluids

### APPENDIX

#### LIST OF TABLES

1. Mensuration	637
2. Cutting Speeds: Lathe Work, Drills, Milling Cutters	638
3. Planer Cutting Speeds	639
4. Diagonals of Hexagons and Squares (Inches)	640
5. Weights of Steel and Wrought Iron	641
6. Different Standards for Wire Gages and Sheet-metal Gages in Use in the United States	644
7. Woodruff Keys and Cutters	645
8. Finding Total Keyway Depth	646
9. Index Table for Fluting Reamers with Unequal Spacing	647
10. Tooth Parts of Gears	648
11. The Dimensions of Gears by Metric Pitch	649
12. Offsets for Obtaining Clearance on Milling Cutters	650
13. Trigonometrical Formulas, Etc.	651
14. Trigonometric Functions	652
15. Decimal Equivalents of the Number and Letter Sizes of Twist Drills	667
16. Cutting Fluid Recommendations	668
INDEX	669



# The Shaper

---

## CHAPTER 1

---

### Shaper Construction

The function of the shaper is, primarily, the production of flat surfaces. The work is held on an adjustable worktable, or more often in a vise fastened to the worktable, while the cutting tool, which is given a reciprocating motion, that is, caused to move forward and back, peels off a chip on the cutting stroke. At the end of the return stroke the feed operates to move the table (and work) the desired amount.

Shapers are classified as to size (14, 16, 20 in., etc.) by the maximum length of the cut that may be taken, and a standard shaper of a given size will hold and machine a cube of that size.

The *crank* shaper (Fig. 1-1), in which the tool carrier is driven forward and backward by an oscillating arm operated by a crankpin in the main driving gear, or "bull wheel," and in which the feed is transmitted to the worktable by ratchet-and-pawl mechanism, is so commonly used as to be termed standard.

In machine construction, circular motion may be changed to reciprocating motion in several ways; for example, through a cam, an eccentric, or a crankpin. In the standard shaper, the crankpin is used. The *reciprocating* motion (forward and return) is given to the ram by the circular motion of the large gear, called the *crank gear* or the *bull wheel*, acting through a crankpin and an oscillating arm, or *rocker* arm.

The lengths of shaper jobs vary, and as the length of the stroke should be only about  $\frac{3}{4}$  in. longer than the cut to be taken, provision is made to change the stroke to any length from zero to maximum.

It should be noted, however, that the *hydraulic* shaper (Fig. 1-2) is becoming increasingly popular. The tools used, the work-holding

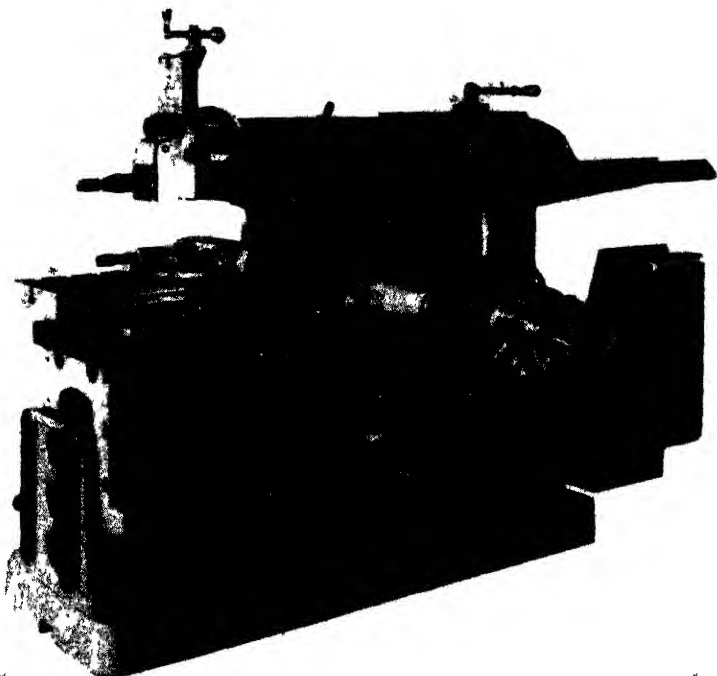
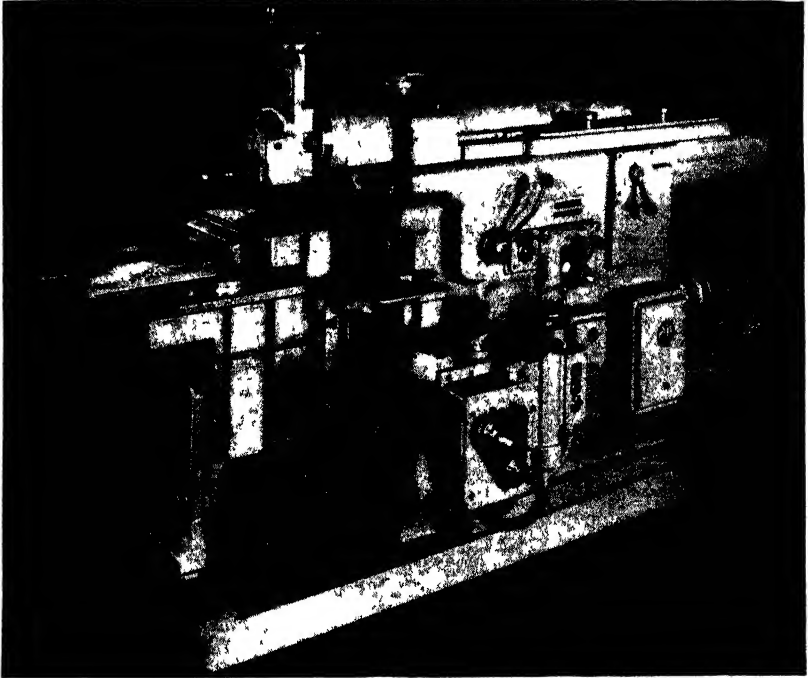


Fig. 1-1. A standard crank shaper (*The Cincinnati Shaper Company*)

devices, the methods, and the general operations are the same for either type.

### VALUE OF THE SHAPER

The relative values of different methods of doing a job, or of the kinds of machines to use, is one of the most profitable and interesting studies in machine-shop work. For example, for a small number of pieces it may be better to machine one piece at a time in a shaper; for a larger number of pieces it may be more efficient to set up and plane several at a time in a planer. It may be cheaper and quicker to take one or more cuts on, say, 25 pieces in a shaper or planer rather than in a milling machine; on the other hand, if there are enough pieces to make the extra initial expense worth while, it probably



**Fig. 1-2.** Hydraulic shaper. (*The Rockford Machine Tool Company*)

would be much better to provide a special fixture and a special cutter, and to machine them in the milling machine.

The shaper is especially adapted to small work which may be held in a vise bolted to the worktable. The tool head is so constructed as to permit of horizontal, vertical, or angular cuts being taken. For toolroom work, such as punch and die work or jig and fixture parts, and on short work for other special tools or machines, the shaper is practically indispensable.

The cutting tool is easily ground to the desired shape for the cut to be taken and, when dull, may be quickly sharpened. The ranges of stroke and position of stroke, of vertical adjustment of worktable, of feeds—lateral, vertical, and angular—together with the adaptability of the single cutting tool, serve to make the shaper more efficient for many jobs than the milling machine would be. This is

especially true in model work or tool work involving only a few pieces. On the average shorter cuts within its capacity, the shaper is more efficient than the planer for the following reasons: It costs less to buy, it takes less power to run, occupies less space in the shop, is about one-third quicker, the work is more easily adjusted, and generally speaking less skill is required in operation.

A wide variety of very accurate work may be easily and quickly accomplished in the shaper if the machine is in good condition, clean, and well oiled, and if the operator understands its construction and the principles of its operation.

### PARTS OF THE SHAPER

On the following pages, a standard crank-driven shaper is illustrated (Figs. 1-3 and 1-4) and the major parts are identified and their functions described. In connection with the job of operating a shaper, the learner should study the illustrations (and machine) and the text carefully, in order to become familiar with the names, locations, and functions of these parts.

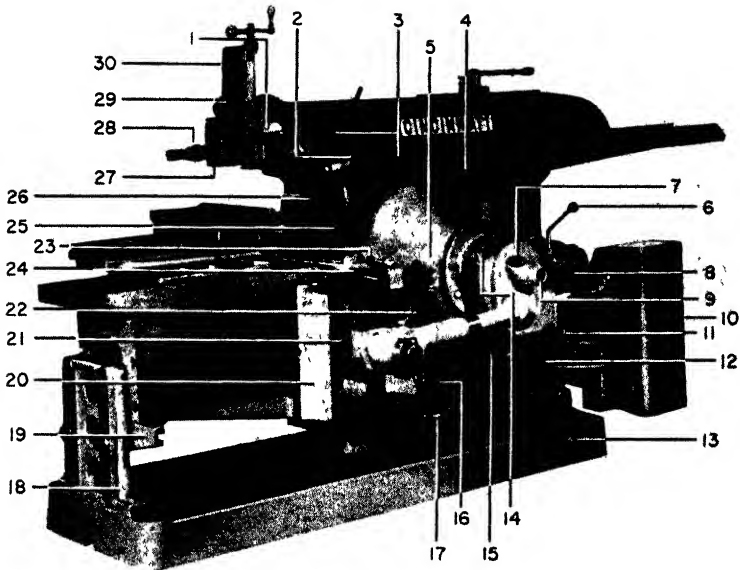
A machinist who can intelligently run a lathe made by a manufacturer in Cincinnati will have no particular difficulty in operating a lathe made by another company in Hartford. These lathes may have different features in design but, in principle, they are alike in construction and operation. So with shaper work. A shaper is built for certain operations, and the machinist who understands the construction of a given standard shaper will have no trouble in understanding quickly the constructional features, that is, the functions of the various levers, handles, etc., of any shaper.

**Names and Functions.** For the parts of the standard crank-driven shaper illustrated in Fig. 1-3 (front view), study the following:

1. *Toolslide Clamp Screw.* Used to clamp the head to the head swivel when shaping with the horizontal feed.

2. *Serial Number.* Each shaper manufactured is numbered. This number is the serial number and is used as a means of identification by the manufacturer as to its size, date of manufacture, type, etc.

3. *Finished Pads.* Used to attach the power feed to the head.



- |                                |                                   |
|--------------------------------|-----------------------------------|
| 1. Toolslide clamp screw       | 16. Rail-elevating manual control |
| 2. Serial number               | 17. Cross-feed safety crank       |
| 3. Finished pads               | 18. Table support                 |
| 4. Tool shelf                  | 19. Table-support bearing         |
| 5. Start and stop buttons      | 20. Apron                         |
| 6. Back-gear lever             | 21. Cross-feed screw              |
| 7. Stroke-indicator dial       | 22. Cross-feed engagement lever   |
| 8. Speed-indicator plate       | 23. Clutch and brake lever        |
| 9. Stroke-adjusting shaft      | 24. Rail-clamp control            |
| 10. Motor starter              | 25. Column rail bearing           |
| 11. Gearshift lever            | 26. Column throat-chip guard      |
| 12. Transmission drain plug    | 27. Clapper                       |
| 13. Oil-sight gage             | 28. Tool post                     |
| 14. Power cross-feed selector  | 29. Clapper box                   |
| 15. Power rapid-traverse lever | 30. Toolslide                     |

**Fig. 1-3.** Parts of the shaper, front view. (The Cincinnati Shaper Company)



4. *Tool Shelf.* A place for tools.

5. *Start and Stop Buttons.* Generally, *black* is used for starting the machine and *red* for stopping the machine.

6. *Back Gear Lever.* Gives two ranges of speeds with four changes in each range, making a selection of eight speeds.

7. *Stroke-indicator Dial.* Shows the length of the stroke in inches.

8. *Speed-indicator Plate.* A direct-reading indicator for speeds. Adjustments are easily made from the operator's natural working position.

9. *Stroke-adjusting Shaft.* Used to adjust length of stroke. The length of stroke is maintained without the use of a clamping nut on the stroke-adjusting shaft, the purpose of the nut being fulfilled automatically. The length of the stroke may be changed while the ram is in motion. A guard covers the stroke-adjusting shaft.

10. *Motor Starter.* Electrical device that helps to start the motor when the button is pushed. Thus, an electrical overload on the motor is avoided.

11. *Gearshift Lever.* Used to shift the gears in the internal transmission mechanism. This transmission provides eight selective speeds, covering a wide range of desired speeds. The changes are made by two levers brought within easy reach of the operating position. These speeds are shown on the speed indicator. The ease with which speed changes can be made encourages the operator to use the correct cutting speed at all times. The gears are housed in a gear chamber, which forms an enclosed reservoir, free from dirt and grit, for the oil in lubricating both the speed gears and the rest of the machine. *Do not change gears while machine is in motion.*

12. *Transmission Drain Plug.* Plug used to hold the oil in the gear chamber. It is opened to take out the old and worn oil.

13. *Oil-sight Gage.* Visible gage showing the height of oil in the oil reservoir.

✓ 14. *Power Cross-feed Selector.* Used to indicate the kind of feed desired. The unique feature of the feeding motion of this particular machine is that it is actuated by a series of cams and not by an eccentric and a ratchet. This gives a smooth, rather than an abrupt, movement and enables the entire feed under any conditions to be confined wholly within the return stroke.

There are 11 feeds, ranging from 0.010 to 0.170 in. Just a twist of

the wrist changes the feed. A second lever for feed engagement has three positions: "stop," "right-hand," and "left-hand," indicating the direction of the table movement.

✓ 15. *Power Rapid-traverse Lever.* Lever that operates the built-in power rapid traverse to the table. It instantly moves the work up to the tool for the cut. Also, when the piece is finished, time is saved, since the table can be quickly moved (traversed) to one side, so that the work can be loaded or unloaded without interference of the tool and the post.

16. *Rail-elevating Manual Control.* Used to raise or lower the rail by hand.

17. *Cross-feed Safety Crank.* Used for traversing the table right or left by hand feed.

18. *Table Support.* Supports table, the sliding action taking place at the bottom of the table instead of at the shaper base. With this type of support, parallel action is not dependent upon the exact alignment of the base.

19. *Table-support Bearing.* Holds the table and allows the table to feed horizontally.

20. *Apron.* Carries the table and is hooked over the rail, and moves right and left on the rail.

21. *Cross-feed Screw.* Moves the apron right and left on the rail.

22. *Cross-feed Engagement Lever.* Gives left, right, or neutral position.

23. *Clutch and Brake Lever.* Starts and stops the machine. This machine uses an electric clutch.

24. *Rail-clamp Control.* Clamps the rail to the column when shaping.

25. *Column-rail Bearing.* Bearing on which the rail operates to raise or lower the table.

26. *Column-throat Chip Guard.* Prevents chips from falling into the column.

27. *Clapper.* Holds the tool post that supports the cutting tool.

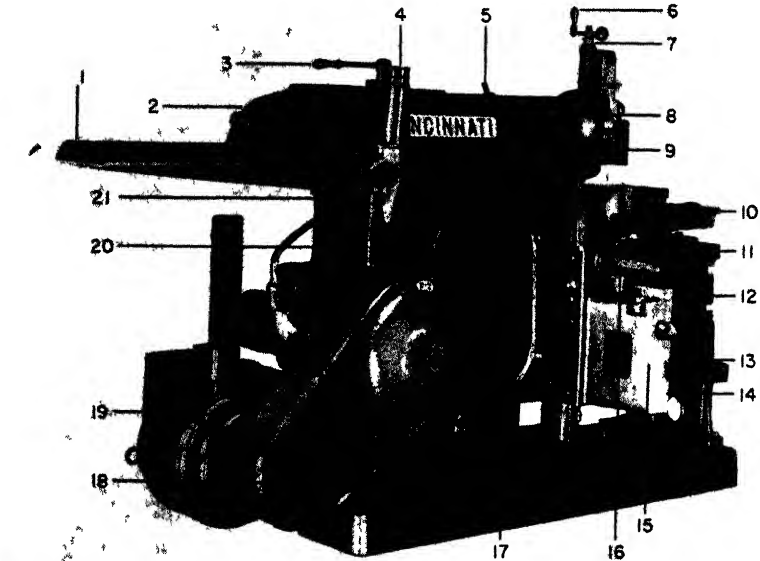
28. *Tool Post.* Holds the cutting tools.

29. *Clapper Box.* Holds the clapper.

30. *Toolslide.* Raises and lowers, to feed the tool down or up.

Figure 1-4 shows a rear view of the shaper with the parts identified. Study these parts carefully and note their locations.

1. *Ram Guard.* Covers the ram at the rear of the machine.
2. *Ram.* The movable part of the shaper which carries the tool.
3. *Ram Clamp.* Clamps the ram at different positions of the stroke.



- |  |                         |
|--|-------------------------|
| 1 Ram guard                            | 11. Table               |
| 2 Ram                                  | 12-14 Bearings          |
| 3. Ram clamp                           | 15 Crossrail            |
| 4. Sight-feed oil distribution station | 16 Crossrail chip guard |
| 5. Ram-positioning shaft               | 17 Base                 |
| 6. Ball crank                          | 18 Motor-drive guard    |
| 7. Feed-screw dial                     | 19 Motor                |
| 8. Graduated-head swivel               | 20 Column               |
| 9. Ramway                              | 21 Ram-gib adjustment   |
| 10. Vise                               |                         |

**Fig. 1-4.** Parts of the shaper, rear view. (*The Cincinnati Shaper Company*)

4. *Sight-feed Oil-distribution Station.* Shows whether oil is circulating in the automatic oiling system.

5. *Ram-positioning Shaft.* Used to change the position of the ram on the stroke.

6. *Ball Crank*. Used to raise or lower the toolslide.
7. *Feed-screw Dial*. Indicates the amount of feed on the toolslide.
8. *Graduated Head Swivel*. Used to swivel the head for angular shaping.
9. *Ramway*. Way on which the ram travels.
10. *Vise*. Device to hold work on table of the shaper.
11. *Table*. Support of the vise; work may be bolted to it.
12. )
13. ) *Bearings*. Bearings for apron on the rail.
14. )
15. *Crossrail*. Used to carry the worktable and saddle; also part of the table feeding mechanism.
16. *Crossrail Chip Guard*. Used to prevent chips from getting in between the column and the crossrail.
17. *Base*. Pan-shaped, to keep oil off the floor.
18. *Motor-drive Guard*. Guard for the pulleys and belts used in driving the machine.
19. *Motor*. Electric motor used in driving the machine.
20. *Column*. Main support for the operating mechanism. The top is machined and scraped to form a flat bearing for the ram.
21. *Ram-gib Adjustment*. Used to adjust the bearing clearance between the ram and the ram bearing.

### REASONS FOR GIB ADJUSTMENTS

Accuracy depends a great deal upon the proper adjustment of gibs. Gib adjustment also is important in smoothness of operation and cutting. Accordingly, *keep all gibs properly adjusted*.

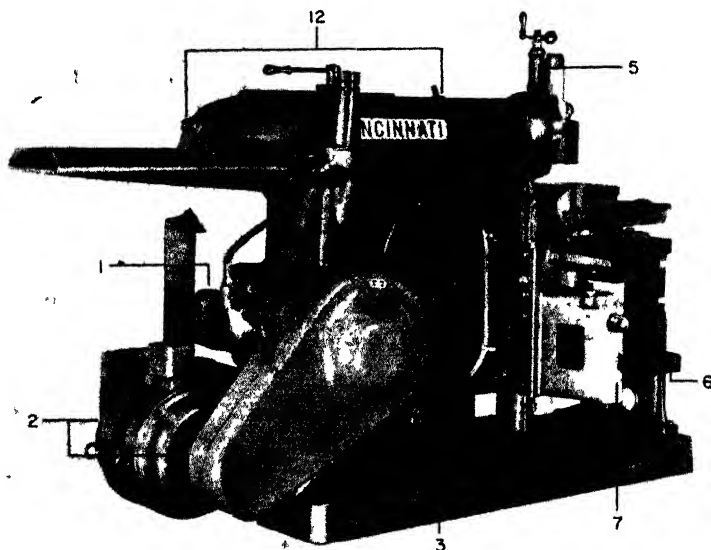
In general, gibs should be adjusted with a minimum clearance. A small clearance on a properly fitted bearing is favorable to the formation of a strong oil wedge or film. When making adjustment, be sure that uneven wear has not taken place. That is, movements of the table, ram, and sliding block are usually confined to a certain portion of the entire travel. Accordingly, after a long period of time, there will be more wear in this portion than elsewhere. If a **gib** is adjusted for the worn portion, it will be tight for the portion that is little used. This condition exists only after a long period of operation and eventually requires refitting. However, in the meantime, **the**

gibs are still useful in keeping proper clearance between the working parts.

When adjustment is necessary, taper gibs should be drawn up snugly. The gib should then be backed off or relieved until a clearance of not less than 0.002 in. is obtained between the glazed bearing surfaces. Further adjustment may be required, depending on conditions and on the operation of the shaper.

### LUBRICATING THE SHAPER

The most important factor in the life of any machine is *proper lubrication*. There are definite places on all machines that *must* be oiled daily while other parts may be oiled weekly, monthly, etc. An apprentice must learn very early in his training that an oiled machine is usually a trouble-free machine.



- |                                     |                          |
|-------------------------------------|--------------------------|
| 1. Oil reservoir                    | 6. Table support surface |
| 2. Motor                            | 7. Rail sliding surface  |
| 3. Return basin and main reservoir  | 12. Oil holes of ram     |
| 5. Sliding surface of the tool head |                          |

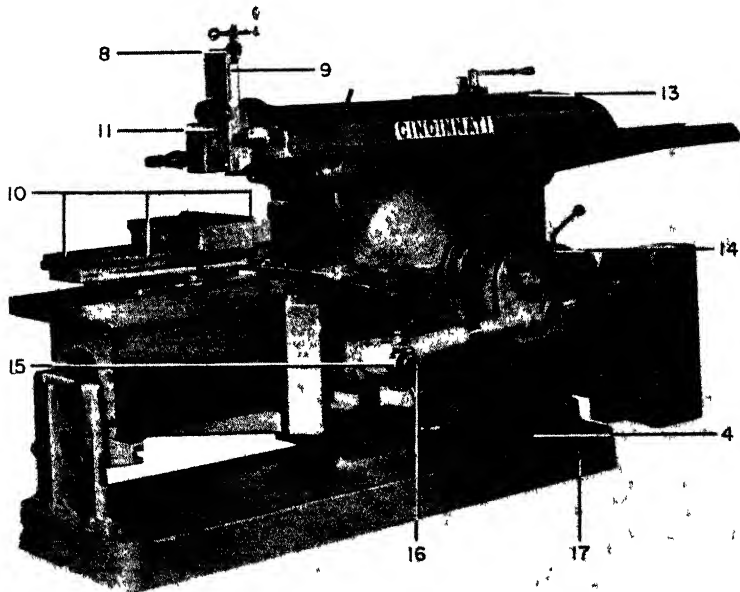
**Fig. 1-5.** Lubricating points. (*The Cincinnati Shaper Company*)

Figures 1-5 and 1-6 show the parts to be oiled. Study these illustrations very carefully and remember what parts are to be oiled daily, weekly, monthly, etc., and be sure that you do the required oiling.

**Before Starting the Machine.** Before the shaper is started, the following four items must be performed (see Figs. 1-5 and 1-6 for location of oiling points).

**NOTE:** Required *only* on new machines or when changing oil.

1. Fill transmission reservoir until oil overflows into the return basin.
2. Lubricate the motor according to the motor manufacturer's recommendations. *Do not overlubricate.*



- |                             |                                 |
|-----------------------------|---------------------------------|
| 4. Oil-pressure gage        | 13. Ram-adjusting screw         |
| 8. Feed-screw bearing       | 14. Speed-change-lever bearings |
| 9. Feed screw               | 15. Crank clutch                |
| 10. Sliding surface of vise | 16. Oil feedbox                 |
| 11. Clapper pin             | 17. Oil-sight gage              |

**Fig. 1-6.** Lubricating points. (*The Cincinnati Shaper Company*)

3. After filling the transmission reservoir, open the column door and fill the return basin until oil overflows to the main reservoir.
4. After filling the return basin, remove the main reservoir cover and fill with oil until the level is  $\frac{1}{2}$  in. from the opening. Add oil as required.

**Daily Oilings.** These oilings *must* be done every day before the machine is started.

1. Clean and oil the sliding surface of the tool head.
2. Clean the surface of the table.
3. Clean the sliding surfaces of the rail.
4. Oil the feed-screw bearing.
5. Oil the feed screw.
6. Clean and oil the sliding surfaces of the vise. Fill oil holes.
7. Oil the clapper pin; clean frequently.

**Weekly Oilings.** These parts should be oiled every week. As a suggestion, choose Monday of each week to do the oiling job, or the first workday of the week if Monday happens to be a holiday.

1. Fill the oil hole at rear of the ram and the two oil holes near the ram adjustment shaft.
2. Oil the ram-adjusting screw through the opening in the ram.
3. Oil the speed-change-lever bearings.
4. Oil the crank clutch.

**Monthly Oilings.** Remove the plug and add oil to the feedbox.

**NOTE:** Do not allow the oil level to fall below the sight gage when the shaper is stopped.

## OPERATION OF THE SHAPER

It is suggested that the beginner carefully study the following pages on the operation of the shaper, so that he may be able to go to the machine and, with a little help from the instructor, get to know how to operate the machine. Study the illustrations very carefully as you read the text material.

### Starting

1. Put the gearshift lever in neutral position and see that the stroke dial reads zero.

Eleven feeds, ranging from 0.010 in. to 0.170 in. are usually provided. The amount of feed is conveniently controlled by means of a lever, mounted on a direct-reading dial, indicating the feed in thousandths of an inch. All feed changes may be made while the machine is running.

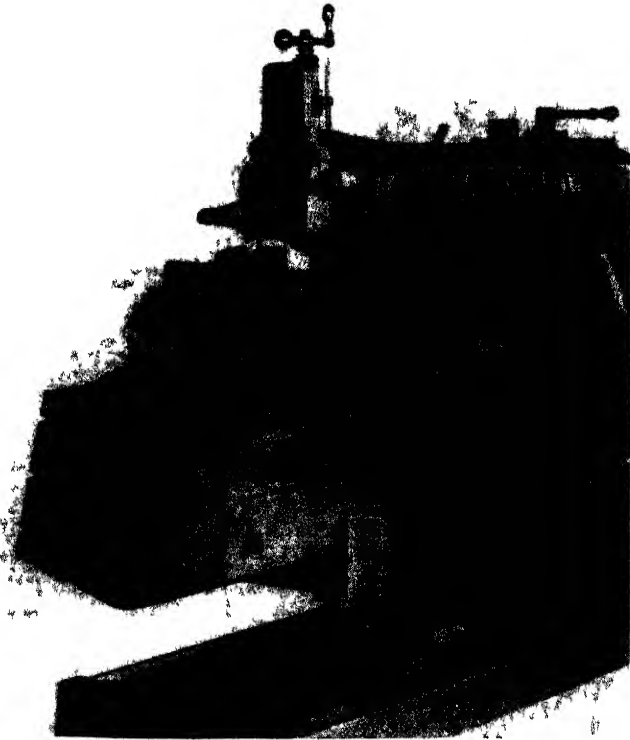


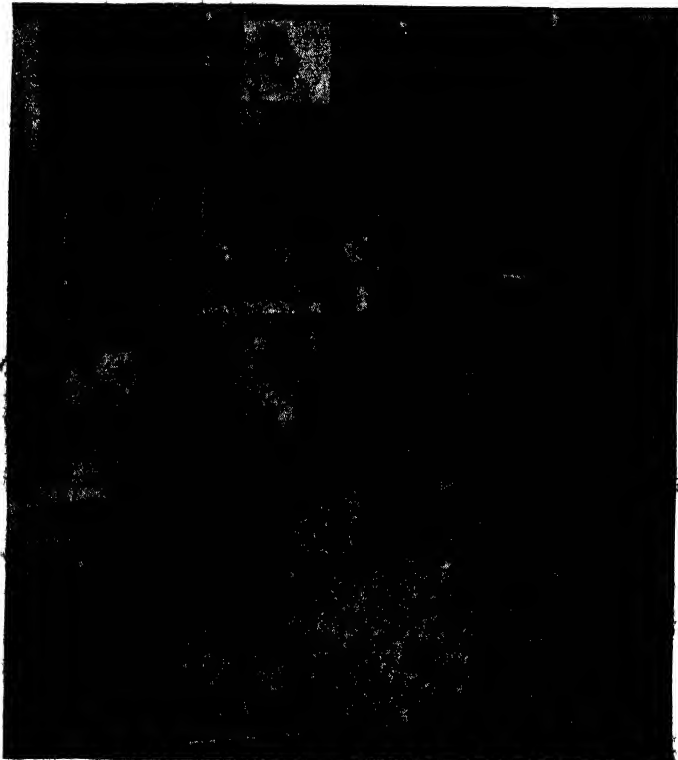
Fig. 1-11. The universal table (*The Cincinnati Shaper Company*)

**Worktables.** Worktables, usually supplied with shapers, may be of two kinds: *plain* and *universal*. The plain type is the one usually supplied unless the universal is specified. Figure 1-10 shows a plain type and Fig. 1-11, the universal.

The worktable may be fed horizontally either by hand or by power, and it may be adjusted vertically to provide for different



jobs which may vary considerably in height. This type of table cannot be swiveled or turned but is stationary in position, bolted to the saddle. It is provided with T slots on the top and on both sides, for the purpose of holding bolts for clamping the work or the work-holding devices. Figure 1-12 illustrates a casting being shaped while



**Fig. 1-12.** Piece clamped to the table. A side cut is being taken with the clapper box in an upright position. In this position, the operator must make sure that it will clear the top of the work. Some machinists prefer to set the clapper box over in setting up the same job. (*The Cincinnati Shaper Company*)

bolted to the table. Figure 1-13 shows a piece held in a vise which is bolted to the table.

Universal tables, in combination with the swivel vise, permit the work to be rotated. This type of table is especially useful in tool and

die shops. The table usually has one solid face, similar to the plain table, and one tilting face with adjustment up to 15 deg. either way from the horizontal and on an axis at right angles to the trunnion. Figure 1-14 shows the use of such a table in combination with a swivel vise.

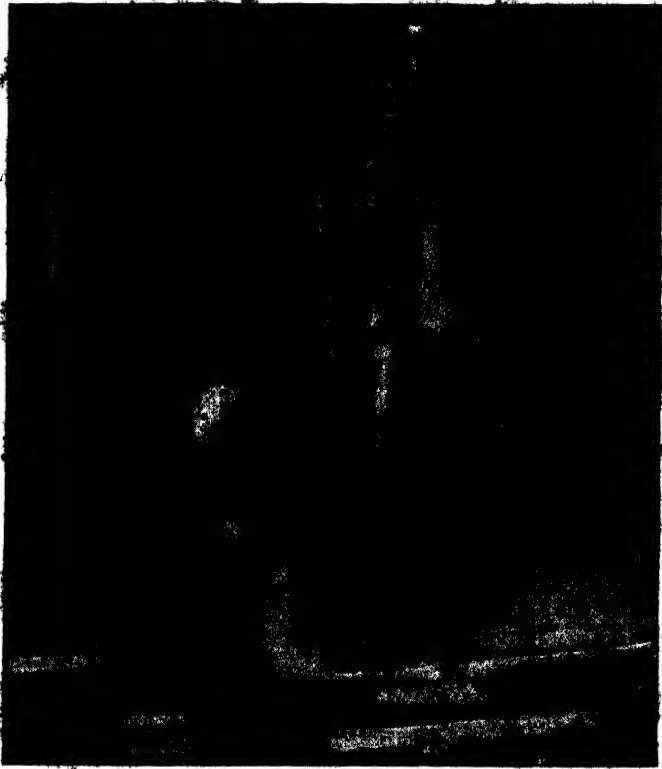


Fig. 1-13. A piece being held in a shaper vise. (*The Cincinnati Shaper Company*)

**Tool Head: Vertical and Angular Downfeed.** The toolhead (Fig. 1-15) is designed to hold the tool and also to be used in adjusting the tool for the desired cut. A graduated collar on the downfeed screw serves to indicate the movement of the slide (and tool) in thousandths of an inch. Moreover, the slide and the screw permit a

considerable amount of downfeed and, because of the swivel construction between the head and the ram, this feed may be vertical or at any desired angle in the plane of the swivel. That is, a vertical cut of considerable depth, or a fairly wide bevel cut may be taken in the shaper by means of the downfeed. The swivel headplate is



**Fig. 1-14.** Use of the universal table in combination with a swivel vise. (*The Cincinnati Shaper Company*)

graduated in degrees, and is easily adjusted after the binding bolts have been loosened.

The cutting tool is held in the tool post securely against the tool block, or "clapper block." The tool block fits snugly to the sides and back of the clapper box and is held by the hinge pin.

1. The ball crank on the top of the vertical feed screw is for manually feeding the tool head up or down. Directly below the crank is a graduated collar which shows the amount of travel. Each graduation of the dial represents a movement of 0.001 in. of the tool head. A power feeding mechanism may be obtained for the tool head when so ordered.

2. The length and position of the ram stroke is determined by the setting of these knobs.

3. Reversal of the direction of the ram stroke at any point during either cutting or return is accomplished by means of this lever.

4. This lever starts, stops, and selects the speed of the ram.

5. This knob and plunger must be pulled outward to allow lever 4 to be shifted to the high-speed range.

6. The valve operated by this lever varies the quantity of oil delivered to the ram cylinder and thereby governs the speed of the ram.

7. The amount of cross or vertical feed to the table is regulated by this handwheel.

8. This valve will be used quite frequently. It is for closing off the oil supply to the feed cylinder or, if the feed piston seems to have too much of a pounding action, it may be softened by adjusting this valve.

9. When the crossrail is to be raised or lowered by hand, the safety crank is to be used on this shaft.

10. This is the screw for moving the table along the crossrail. 11 and 12. These two levers are used in conjunction with each other. Lever 11 selects the setting for either vertical or horizontal movement of the table and, after it has been set, lever 12 selects the direction of movement for that setting.

13. Before lowering the table, be sure to loosen the clamp nuts on the outboard support. After the table has been moved to the desired position, these nuts should be tightened in order to provide a rigid support for the table during the shaping operation.

14. Plates used to hold the crossrail to the column.

### **QUESTIONS ON SHAPER CONSTRUCTION**

1. What is the function of a shaper?
2. How are shapers classified as to size and type?

3. What is meant by reciprocating motion? How does it apply to the shaper?
4. What are the differences between crank and hydraulic shapers?
5. Of what value is the shaper in a machine shop? Be very specific in your answer.
6. Name 10 major parts of the shaper.
7. Describe the functions of these parts.
8. Why should machine tools be lubricated?
9. What parts of the shaper must be lubricated daily?
10. Why must the machine be kept clean at all times?
11. How many speeds has the standard shaper?
12. What is the usual range of feeds?
13. In what directions may the tool be fed to the work?
14. How is the table moved? In what directions may the plain table be moved? the universal table?
15. What advantages has the universal table over the plain table?
16. What is meant by power rapid traverse?
17. How does it work?
18. What is meant by manual feed? power feed? How do they work?
19. What is the function of the tool head?
20. How is the feed measured and by what?
21. What is the function of the clapper box?
22. Does the clapper box raise on the return stroke? Why?
23. What advantages, if any, has the hydraulic shaper over the crank type?

## Shaper Work

**Shaper Cutting Tools.** The variety of cuts that may be made in a shaper on any of the metals used in machine work calls for tools of various shapes. Shaping, that is, cutting on a shaper, can be done to the right or to the left. It also includes roughing cuts, finishing cuts, slotting, contouring, undercutting, dovetailing, and a variety of operations. Tools are ground differently for the different cutting operations. Tools can be made from solid bars of steel or they may be made from smaller pieces of tool steel, called *bits*, which are ground to the desired shape and held by being clamped in a tool-holder. The large, solid tools are especially good for very heavy work because they carry away the heat from the cutting edge of the tool more rapidly. There are also toolholders using forged bits. The tool-holder with the ground bit is probably the most popular combination on a shaper.

The shape of the cutting tool varies with the character of the work. The general shapes of shaper-cutting tools for shaping cast iron and mild steel as recommended by The Cincinnati Shaper Company are shown in Figs. 2-1 and 2-2. Study these shapes very carefully. It will prove worth while during your apprenticeship as well as for later work on the shaper.

The shape of the tool is also determined by the type of work that is to be done. For the production of an ordinary flat surface, the tool is either right-hand or left-hand. The left-hand tool is more common because it permits the operator to see the cut better than the right-hand tool does. A dovetailing tool is, naturally, quite pointed. A finishing tool is the reverse, because a broad-nosed or square-nosed tool will largely eliminate feed marks, whereas feed marks will be more noticeable with a pointed tool.

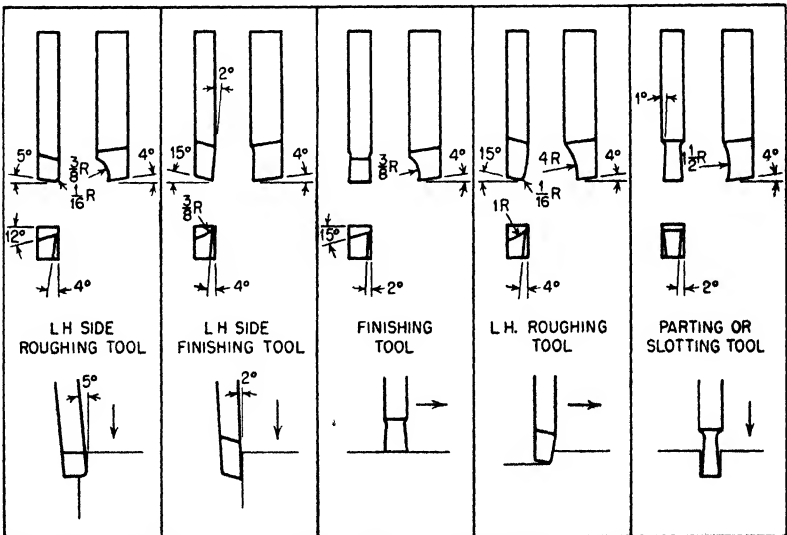
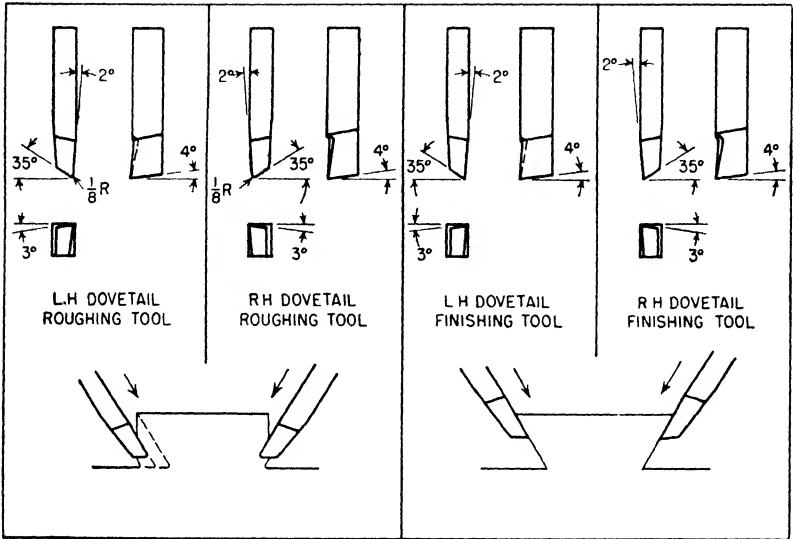


Fig. 2-1. Shaper tools for cutting cast iron. (The Cincinnati Shaper Company)

There are other factors that help in the determination of the shape of the tool. These factors are the finish required, the kind of material

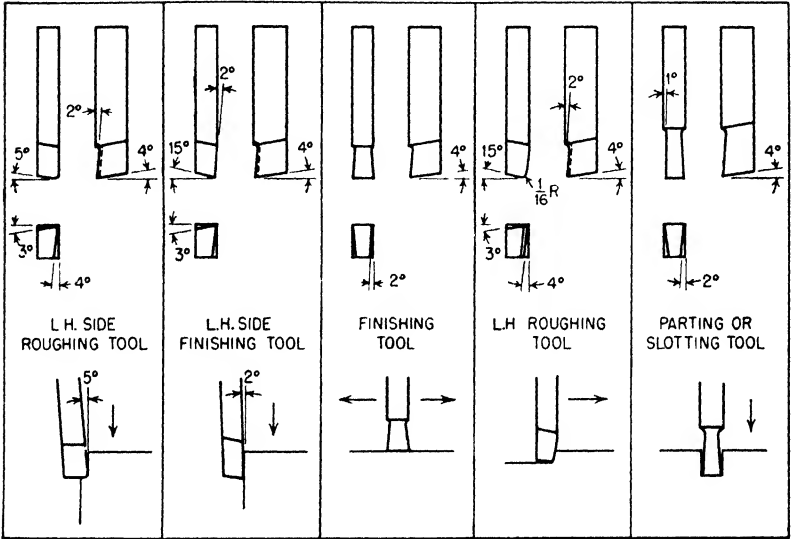


Fig. 2-2. Shaper tools for cutting mild steel. (The Cincinnati Shaper Company)

being cut, and the condition of the machine, as well as feed and speed.

The elements of a shaper tool or a planer tool, that is, the front rake, front clearance, side rake, etc., are in the same relative positions as on the lathe tool, regardless of the fact that the shaper tool when in use is held vertically, while the lathe tool is held horizontally.

**Clearance Angles.** There is no rocker in the tool posts of the shaper, hence the tool cannot be adjusted for clearance; the proper clearance angles must be ground on the tool. As shown in Fig. 2-3, the front clearance angle is 4 deg.

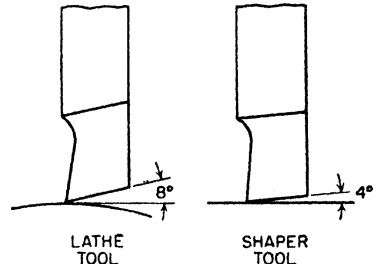


Fig. 2-3. Comparison of front clearance angles of lathe and shaper tool bits.



Since the shaper feed does not operate during the cut as does the lathe feed, a side clearance of 2 or 3 deg. is sufficient.

If a shaper tool is given *too much* front clearance, it will dull quickly because the cutting edge, not being strong because of the lack of supporting metal, crumbles away; if it is given *no* front clearance, the cutting edge cannot get under the chip and will merely rub, spoiling the appearance of the work by leaving grooves and tool-

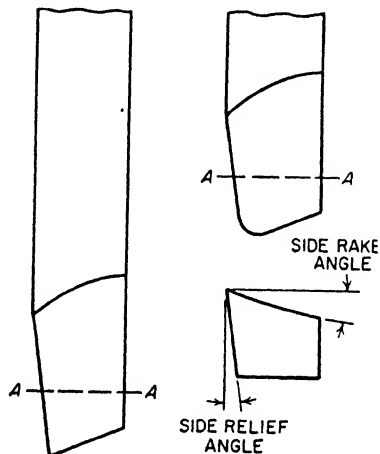


Fig. 2-4. Rake angle and side relief angle on shaper tools. A-A are cross sections of the tools.

marks. The same is true with regard to side clearance. Briefly stated, the shaper cut is a straight-away cut and just sufficient front and side clearance are given the cutting edge of the tool so that there is no tendency for any part of the tool to rub on the work. Remember, the recommended front clearance angle should be 4 deg., and the side clearance angle about 2 or 3 deg.

*Rake angle.* The shaper tool is usually given side rake of 10 deg. or more, depending on the kind of tool and on the hardness of the metal to be machined, but no front rake is given except on finishing tools.

Study Fig. 2-5 carefully for a simple explanation of the cutting action of a shaper tool when a plane surface is being machined. Note that the tool is offset so as to get the tool point toward the center of the shank. This will prevent the tool from digging. Most shaper and planer manufacturers recommend this type of tool for general work.

**Shaping with Carbide Tools.** Almost any type of material that is machinable with high-speed-steel cutting tools can be economically machined with carbide tools. In situations where the life of the tool is short, as for machining chilled cast iron, die steels, etc., the carbide tool is more efficient and economical.

In order that a shaper may be suitable for carbide shaping, it must

be capable of speeds exceeding 100 ft. per min. because it has been determined by experiment and actual industrial conditions that 100 ft. per min. is the absolute minimum speed at which carbides can be economically used. At slower speeds, there is no appreciable difference as to cost of operation between the high-speed tools and the carbide tools.

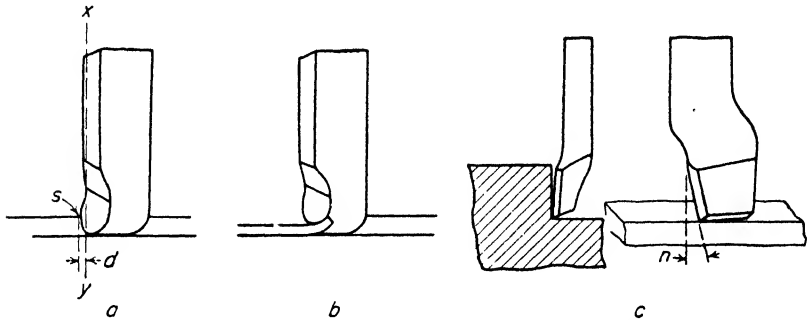


Fig. 2-5. Cutting action of tool when machining a plane surface. Note in view (a) the line  $xy$  is parallel to the base of the tool and therefore the tool has no front rake. Note also that since the cutting edge is given side rake, the start of the cut is made at  $s$  and the distance  $d$  is traversed before the full depth of the cut is taken; thus the tool enters the work gradually and prevents the shock of having the full cutting edge strike the metal at once. The way in which the chip curves is shown in (b). In (c) is shown a side tool with the cutting edge ground flat to take a finishing cut, say,  $\frac{1}{4}$  in. or more wide. Note the angle of shear  $n$  to give an easy start and finish of the cut. A side tool, ground in this way, is much used in shaper and planer work for finishing cast iron.

The shaper must also be capable of producing uniform feeds. This condition must be met; if it is not, excessive tool wear will result because of the varying feeds between strokes.

The shaper must be equipped with a good tool lifter (Fig. 2-6). Sintered tools will not stand up if allowed to drag on the return stroke. On account of the high speed of the machine, it is almost impossible for the operator to lift the clapper box manually on the return stroke of the ram; the tool lifter does exactly that.

The shaper must be in excellent operating condition to ensure accurate work without chatter marks and, at the same time, guarantee long tool life.

The motor should be capable of supplying the needed horsepower when carbide tools are used, because the use of such cutting tools demands greater power. The horsepower requirements will vary in direct proportion to the speed of the machine. Shaping at 150 ft. per min. requires  $1\frac{1}{2}$  times the horsepower used at 100 ft. per min.

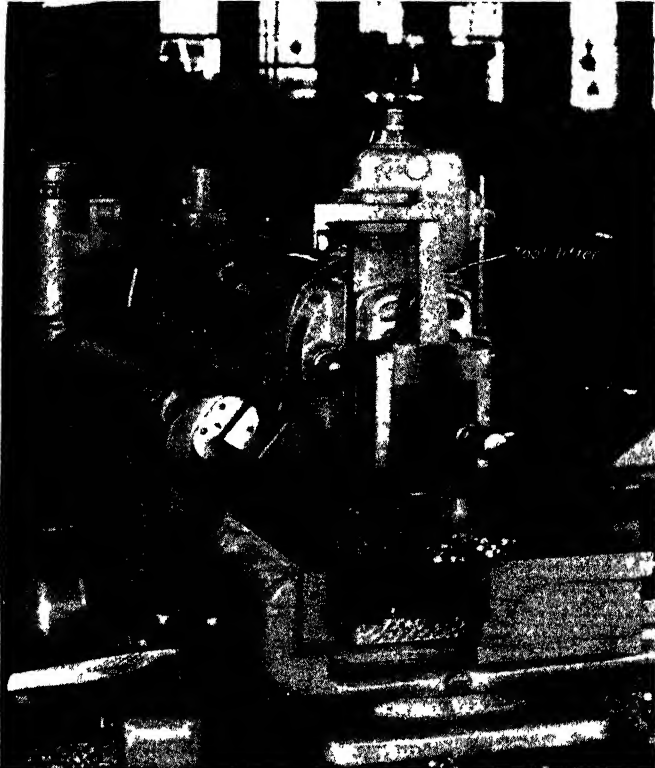


Fig. 2-6. A tool lifter attached to a shaper. (*The Cincinnati Shaper Company*)

**Right-hand and Left-hand Tools.** When a job is being set up in any machine, it is best, if possible, to arrange the work and also the tool in such a way that the operator can readily see the cut from his normal position at the machine, that is, from the position in which he controls the machine. For this reason it is customary when taking a horizontal cut on the shaper or planer to start the cut on

the side toward the operator and, when shoulder or similar cuts are to be made, to arrange the work so that these cuts will come on this side. Many shaper jobs, however, include tongues, grooves, and angles which involve cuts on both sides of the work. Since in work of that kind it often makes for greater accuracy and speed to *machine in one setting of the work all the surfaces possible*, it is necessary to have right-hand and left-hand cutting tools. The terms *right-hand* and *left-hand* as applied to shaper or planer tools are derived from lathe tools of similar shape; that is, a right-hand cutting tool is one that cuts from right to left and a left-hand cutting tool is one that cuts from left to right.

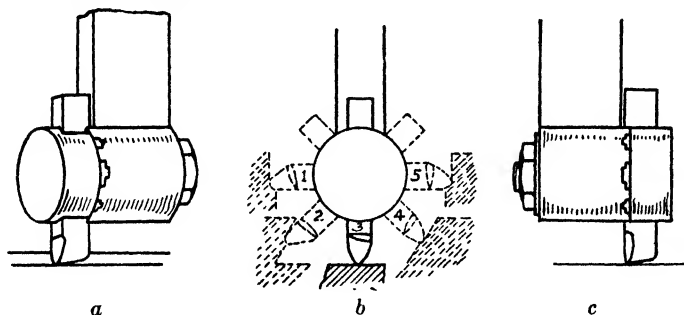


Fig. 2-7. Armstrong planer and shaper toolholder. (a) Normal position for horizontal cut; (b) tool arranged for (1) vertical cut, (2) angular cut (inside angle), (3) horizontal cut, (4) angular cut, (5) vertical cut; (c) toolholder (and tool bit) reversed, brings cutting edge back of shank of toolholder.

**Toolholders.** The toolholder and high-speed-steel bit have largely superseded the forged tool for shaper work. The tool bit may be ground to the shape required to accomplish the desired result for practically any operation. Figure 2-7 shows a patented toolholder (Armstrong) which, in the smaller size, is used for shaper work and, in the larger size, is very efficient for use in the planer. The construction of this toolholder permits the tool bit to be securely and rigidly held in any one of the five positions shown in *b*, so that horizontal, vertical, or angular cuts, either right-hand or left-hand, may be made. Another advantage of this toolholder lies in the fact that for heavy cuts the toolholder may be reversed in the tool post (and, of course, the tool bit is also reversed, [*c*, Fig. 2-7]). Since the cutting edge is then back of the shank of the tool, the tendency of the tool to

chatter or to "dig in" is eliminated. In any case the tool bit should not be allowed to project too far as this will result in unnecessary spring.

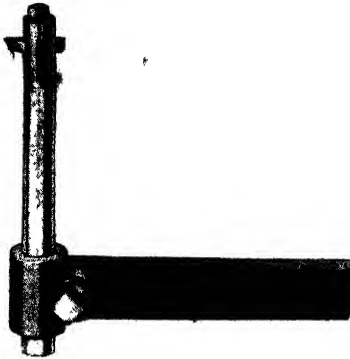


Fig. 2-8. Another type of shaper toolholder. (*Armstrong Bros. Tool Company*)

The lathe-turning toolholder and bit can be used as a shaper tool, provided the tool bit is not given too much clearance, especially too much front clearance. Of course, the position of the bit set at an angle of 20 deg. with the shank of the tool gives a front rake which, while not desirable, is not prohibitive for light cuts.

Other types of toolholders are used in shaper work, and some of them are shown in Figs. 2-8, 2-9, and 2-10. The toolholder shown in Fig. 2-8 should remind you



Fig. 2-9. A large lathe-type toolholder being used in a shaper. (*The Cincinnati Shaper Company*)



Fig. 2-10. Cutting a keyway. (*The Cincinnati Shaper Company*)

of the boring bar used in the lathe. This particular type of holder is used whenever it is necessary to hold the tool far away (comparatively speaking) from the tool post. It is also used whenever the shape of the piece to be machined is such that the cutting must take place in a part of the work away from the tool post. Figure 2-9 shows a large Armstrong holder being used. This is similar to the lathe toolholder but is larger and, most important, the toolbit is *not* at an angle to the holder but parallel to it. Figure 2-10 shows a toolholder similar to that shown in Fig. 2-7 but heavier in construction. The arm is also longer and heavier. With this toolholder, the clapper box must be locked in position.



Fig. 2-11. Tool bit clamped directly to tool post in shaper. (*The Cincinnati Shaper Company*)

There are many instances in which a toolholder is not used. Figure 2-11 shows such an instance. Here the shaper operator is using a solid cutting tool held directly in the tool post. The tool is strong and heavy enough so that no toolholder is necessary. This tool is commonly used for very heavy work.

## QUESTIONS ON SHAPER CUTTING TOOLS

1. Why is it necessary to have many different-shaped tools for work on the shaper?
2. Why is it necessary, at times, to use forged tools?
3. What factors determine the shape of a cutting tool to be used in the shaper?
4. What size of angle is recommended for the front clearance? for the side clearance?
5. What would happen to a tool with a front clearance of 15 deg.?
6. Name some important considerations that must be given when a carbide-tipped tool is being used in a shaper.

7. What is a tool lifter? How does it help the tool?
8. What is meant by a right-hand and a left-hand tool?
9. How may tools be held in the tool post of the shaper?
10. Are toolholders always necessary? State why.

**Speeds and Feeds.** The reason for machining metal parts (in any machine tool) is usually twofold: (1) to remove surplus metal to bring the work to a given size, and (2) to produce a smooth finish on the surface. To accomplish these results, at least two cuts, one or more roughing cuts and a finishing cut, are nearly always necessary. To operate the machine efficiently to produce these results means a reasonable understanding of the proper speed, feed, and depth of cut for roughing and also for finishing.

To understand the cutting speed is comparatively easy; it depends almost entirely on three things: (1) the kind of material being cut is a factor, the softer the material the faster the speed at which it may be cut; (2) the amount of material being removed in a given time is another factor, a light cut may usually be taken at a greater speed than a heavy cut; and (3) the kind of steel from which the cutting tool is made is a very important consideration because a high-speed tool will cut at least at double the speed of a carbon-steel tool.

*Depth of Cut and Feed.* The value of any machine tool depends upon its power, the strength and rigidity of its construction, the rapidity and smoothness of its action, its convenience in operation, and its accuracy. Modern shapers may be classed as particularly rugged machines, carefully designed and accurately built. *Whenever a considerable amount of metal must be removed, the shaper should be made to work during the roughing cut; that is, the cutting speed should be suitable and the depth of cut and feed should be proportioned to remove as big a chip as the shaper will drive, provided that the nature of the work, the way it is held, and the strength of the tool will permit.* This point is entirely basic. It should be emphasized. It applies to other machining as well, on other machine tools. You can "make time" in roughing only. Finishing cannot be hurried. It is impossible to give a rule for the depth of cut or the amount of feed, or for a proportion of feed and cut, but the following suggestions may help the beginner.

With a given tool and the given amount of metal to be removed per cut, a really coarse feed and less depth are not so efficient as a

finer feed and a deeper cut for two reasons: (1) the thick chip does not curl so easily and takes more power, and (2) the tear in the metal is greater, thus producing a rougher surface. A safe rule to follow is to give as much feed as is consistent with the surface desired, and then all the depth of cut that the tool and the motor will stand, provided that amount of metal must be removed.

The following table of (average) cutting speeds and feeds of cutting tools made of carbon and high-speed steels is given for the convenience of the beginner.

Table of Speeds and Feeds

Cutting tool	Cast iron		Machine steel		Carbon steel		Brass	
	Speed	Feed	Speed	Feed	Speed	Feed	Speed	Feed
High-speed steel	60	0.085	80	0.060	50	0.050	160	0.050
Carbon steel	30	0.060	40	0.050	25	0.040	100	0.050

The usual practice is to run the shaper too slowly. It is well for the beginner to calculate the number of strokes necessary to give the proper cutting speed for the work at hand until he gets accustomed to seeing the shaper move fast enough.

For cutting with a carbide-tipped tool, the following chart shows the recommended feeds and speeds with relation to depth of cut as

Chart of Feeds and Speeds

Material	Depth of cut, in.	Feed per stroke, in.	Maximum speed, ft. per min.
C.I., hard	$\frac{1}{32}$ – $\frac{1}{2}$	0.005–0.020	100
C.I., soft	$\frac{1}{32}$ – $\frac{1}{2}$	0.005–0.020	maximum available
Cast steel	$\frac{1}{32}$ – $\frac{1}{4}$	0.005–0.010	150
S.A.E. 1020 steel	$\frac{1}{32}$ – $\frac{7}{16}$	0.010–0.015	100
S.A.E. 1045 steel	$\frac{1}{32}$ – $\frac{3}{8}$	0.010–0.015	150
S.A.E. 1080 steel	$\frac{1}{32}$ – $\frac{1}{4}$	0.005–0.020	150
Die blocks	$\frac{1}{32}$ – $\frac{1}{4}$	0.005–0.020	150
Brass, hard	$\frac{1}{32}$ – $\frac{7}{16}$	0.010–0.015	100



practiced in industry. Consult this chart whenever this type of cutting tool is being used.

Compare both charts and note the differences in speeds, feeds and depths of cut when the various types of cutting tools are being used. Mass production demands (in most cases) that the carbide-tipped tools be used.

*Cutting-speed Calculations.* The calculations for cutting speeds for shaper work are more involved than those for lathe or drill-press work, because the shaper cuts only during the forward stroke and, further, because the return stroke is faster than the cutting stroke.

Given the ratio of return-stroke *time* to cutting-stroke *time* as 2:3, the sum of the terms of the ratio equals 5; and  $\frac{2}{5}$  of the time equals the *time* of the return stroke; and  $\frac{3}{5}$  of the time equals the *time* of the cutting stroke.

Given the length of stroke in inches and the number of strokes per minute, their product gives the number of inches cut during one minute of the machine's operation. Since cutting speed is expressed in feet per minute, this must be multiplied by  $\frac{1}{12}$  to convert the inches to feet. As noted above, the actual time of cutting this distance is  $\frac{3}{5}$  min. Therefore, since distance divided by time equals rate, divide the distance (in feet) by  $\frac{3}{5}$  (that is, multiply by  $\frac{5}{3}$ ) and the result will be the cutting speed. Instead of multiplying in every problem first by  $\frac{1}{12}$  and then by  $\frac{5}{3}$ , it will be quicker to multiply by 0.14 which amounts to the same thing ( $\frac{1}{12} \times \frac{5}{3} = 0.14$  approximately). Hence the following:

**RULE 1:** To obtain cutting speed (CS), *number of cutting strokes* and *length of stroke* being given:

Multiply the number of strokes per minute ( $N$ ) by the length of stroke in inches ( $L$ ) and the product by 0.14.

**FORMULA:**  $0.14NL = CS$

**EXAMPLE:** Length of stroke 8 in. Number of strokes per minute 30. What is the cutting speed?

**SOLUTION:**  $8 \times 30 \times 0.14 = .33.6$  ft. per min.

**RULE 2:** To obtain the number of strokes necessary, required cutting speed and length of stroke being given:

Multiply the cutting speed by 7 and divide by the length of the stroke in inches.

$$\text{FORMULA: } N = \frac{CS \times 7}{L}$$

DERIVATION: From Rule I,  $0.14NL = CS$ , or

$$N = \frac{CS}{L \times 0.14} = \frac{CS}{L} \times \frac{1}{0.14} = \frac{CS \times 7.2}{L}$$

and for practical purposes  $N = \frac{CS \times 7}{L}$  is near enough.

EXAMPLE: How many strokes are required to shape cast iron with a high-speed tool (60 ft. per min.), with a stroke of 5 in.?

$$\text{SOLUTION: } \frac{60 \times 7}{5} = 84 \text{ strokes.}$$

### QUESTIONS ON SPEED, FEED, AND DEPTH OF CUT

1. The proper cutting speed for a given job depends on three factors. What are they? Give an example of each.
2. What is a safe proposition to follow concerning the feed and depth?
3. About what cutting speed will be practical to start with on cast iron? Is the tool you are to use carbon steel or high-speed steel?
4. May it possibly be wise before long to change to a faster speed? To a slower speed? Give reasons.
5. How many strokes per minute are necessary to give the required cutting speed?
6. Do you suppose a machinist would use a formula to calculate the number of strokes necessary? How would he go about it? Of what value is the formula to the beginner?

**Holding the Work.** Most shaper work is held in a vise which is bolted to the top of the shaper table. However, the vise may be removed and work which is too large or otherwise impracticable to hold in the vise may be bolted to the top or the side of the table, or to an angle plate or any special plate or other holding device which can be fastened on the table.

*Shaper Vise.* Figure 2-12 shows a large-opening vise used in shaper operations. The principal parts are the base, the body, the fixed jaw, the movable jaw, the screw, and the plates which are attached to the face of the jaws. The base is bolted to the table of the shaper and is graduated through an arc of 180 deg., with a zero (0) position on the

right and left sides and the 90-deg. mark in the front, midway between the two zero marks.

The body may be swiveled on the base plate to any angle desired, graduations in degrees showing the angular setting. This swivel feature is often useful for beveling ends, shaping adjacent sides or faces at other than 90 deg., etc., but most of the work is done with the vise jaws either parallel with or at right angles to the direction of the cut. Figure 2-13 shows a piece of work held at an angle to the direction of cut other than 90 deg.



**Fig. 2-12.** A large-opening shaper vise (*The Cincinnati Shaper Company*)

The shaper vise is especially strong, the jaws are long and deep, and the adjustment is sufficient to take work of a considerable width. The jaws are usually hardened to prevent them from being scored and dented.

There are shaper vises equipped with double screws rather than with a single screw. Some of these vises, in addition to holding straight work, are used to hold pieces having a slight taper. Figure 2-14 shows a vise with a double screw holding a tapered piece.

Figure 2-15 shows a side vise, (a) showing the side which holds the work and (b), the other side of the vise. This vise has many uses in machine-shop practice.



Fig. 2-13. Shaper vise set at an angle. (*The Cincinnati Shaper Company*)

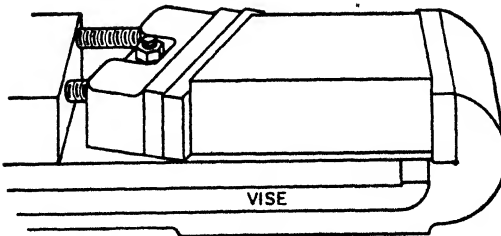


Fig. 2-14. Taper work with a double-screw vise. (*The Cincinnati Shaper Company*)

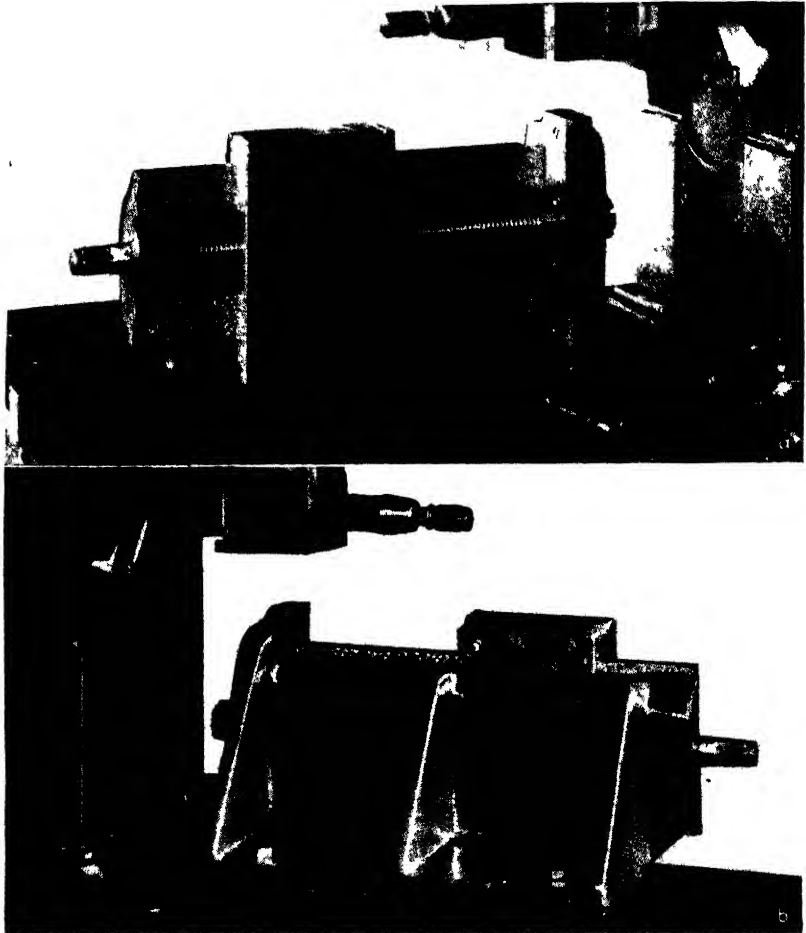


Fig. 2-15. A side vise showing (a) front and (b) back views. (*The Cincinnati Shaper Company*)

Then, again, there are many special vises used in the machine shop that are designed for specific or special jobs. Such a vise has a very limited use in other shops where different types of jobs are done.

*Parallels* (Fig. 2-16). *Parallels* are pieces of cast iron or steel of rectangular cross section, of considerable length in proportion to their width and thickness, with opposite sides parallel and adjacent

sides square. They are used to raise the work to the required height in the vise or otherwise to bolster and level it. Parallels are made in pairs. Two or more pairs may often be used together.

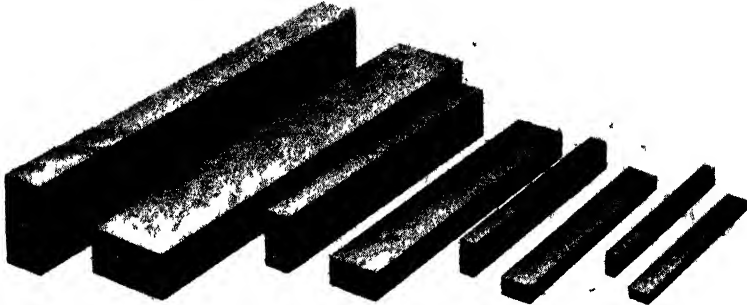


Fig. 2-16. Several sizes of parallels. Note sizes marked on edges. (The Taft-Pierce Manufacturing Company)

Another type of parallel is the *angular parallel* (Fig. 2-17). These parallels are similar to the regular parallels except that one side of each parallel is machined "out of square," with the adjacent side at a certain angle.

*Angle Plates* (Fig. 2-18). Angle plates are of any size required and are usually made of cast iron. An angle plate is composed of two members, or wings, the outer surfaces of which are machined flat at an angle of 90 deg. to each other. When in use, one surface is bolted to the table and the work is fastened to the other surface. Some angle plates have one of the inner surfaces finished, which permits work being clamped or bolted to this surface when desirable. Holes are drilled where necessary for the clamping bolts. Sometimes tapped holes are more convenient for the purpose of clamping the work. Often C clamps are used for this purpose.

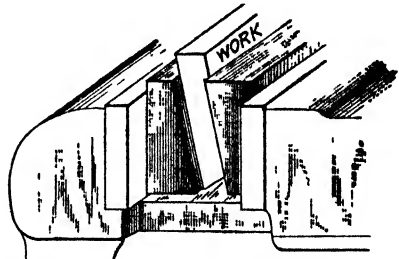


Fig. 2-17. Application of angular parallels.

*Hold-downs or Grippers* (Fig. 2-19). Hold-downs, or grippers, are thin pieces of approximately triangular cross section, of the length



Fig. 2-18. Angle plates (*The Taft-Pierce Manufacturing Company*)

desired (6 in. more or less), used most frequently to hold thin pieces in the vise. The narrow edge is rounded and the opposite edge is

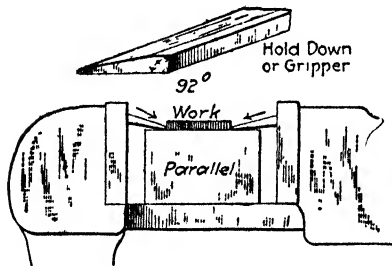


Fig. 2-19. Action of hold-downs

beveled about 2 deg. toward the bottom. This ensures the work's being held down on the bottom of the vise or on a parallel, as the case may be. Hold-downs are especially valuable when parallels of the required height to raise the thinner pieces just above the vise jaws are not available. They are very useful also when it is

desired to finish only two opposite surfaces of a piece.

*Toe Dogs* (Fig. 2-20). Toe dogs also are used to hold thin pieces in place. These dogs are held on the table and, with the help of two adjusting screws, the thin work is held in place.

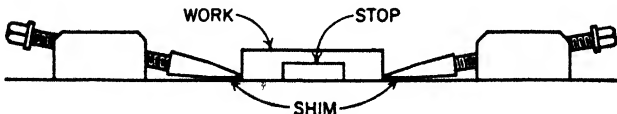


Fig. 2-20. Holding thin work with toe dogs (*The Cincinnati Shaper Company*)

*Shaper-index Centers* (Fig. 2-21). Shaper-index centers are very useful for certain curved surfaces that are partially cylindrical but

have projecting portions and consequently cannot be turned in a lathe. The splined shaft in the illustration is a good example of the use of index centers. They may often be used for finishing surfaces of pieces held on a mandrel more advantageously than the work



**Fig. 2-21.** Using index centers to cut splines. (*The Cincinnati Shaper Company*)

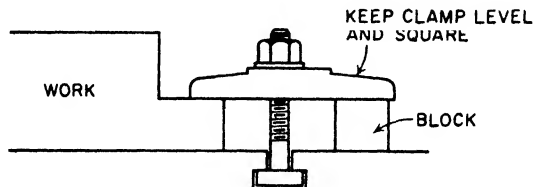
could be done in a milling machine. The construction of the index head and tailstock permits of a variety of indexing<sup>1</sup> operations.

Notice the various circles of holes in the plate that revolves on the worm. Notice, too, the pin that is used to fix the position of the plate. This procedure is further explained in Chapter 9 of this volume.

<sup>1</sup> Indexing is the method used in accurately dividing the circumference of a circle into any number of equal parts.



**Clamping Work to the Table.** Clamping work to the table properly is the first prerequisite for accurate work done on the shaper. If the work is *not* clamped properly, many things may happen. First of all, the work may move out of position and then it is usually spoiled; second, the tool may get caught in parts of the

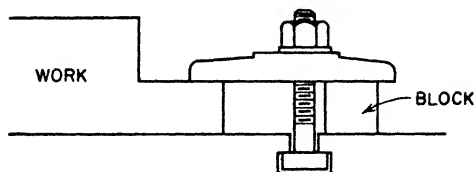


RIGHT

CLAMPING EFFECT IS ON WORK

Fig. 2-22. Correct method of clamping work to the table of a shaper. (*The Cincinnati Shaper Company*)

clamping devices and so it may be broken; third, somebody may get hurt when things start to fly. The object in proper clamping is to have the work absorb the clamping effect; that is, the pressure in clamping must be *on* the work, *not* on the block used in clamping. Remember this *always*.



WRONG

CLAMPING EFFECT IS ON BLOCK

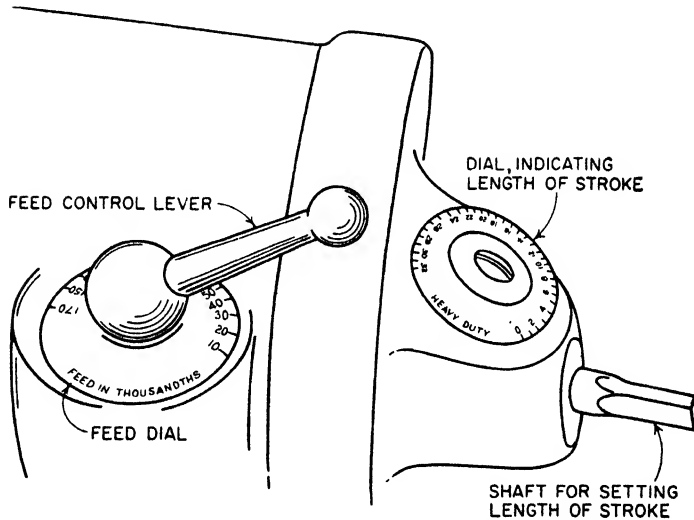
Fig. 2-23. Incorrect way of clamping work to a shaper table. (*The Cincinnati Shaper Company*)

Figure 2-22 shows the proper way to clamp work to the shaper table and Fig. 2-23 shows an incorrect way to clamp work to the table. Note the positions of the work in the two illustrations. In the right way (Fig. 2-22), the clamp is set directly over the work and the bolt is in the middle of the setup; while in the wrong way of

know how to change the stroke without too much help. It is a simple matter, and a little practice under the supervision of the instructor or the foreman should do the trick. Study the following procedure carefully.

### HOW TO ADJUST THE LENGTH OF THE STROKE

1. Loosen the clamping nut that locks the stroke setting shaft in position. If the shaper on which you are working has automatic clamping, like the one shown in Fig. 1-3, adjust the stroke-adjusting shaft (part 9, Fig. 1-3).



**Fig. 2-35.** Cincinnati stroke-adjusting shaft and feed dial. (*The Cincinnati Shaper Company*)

2. Using the crank provided for turning the stroke setting shaft, turn this shaft *in the direction* desired until the pointer on the stroke indicator dial (part 7, Fig. 1-3) registers the desired length of stroke. *Remember to take care of the added length for overtravel.*
3. If the crank is not needed, turn the shaft until the required reading is registered on the stroke indicator dial (Fig. 2-35).
4. After setting the desired length of stroke, tighten the clamping nut if one is used.

## SOME SHAPER OPERATIONS

**Horizontal Cut.** When the work is fed in a horizontal direction under the reciprocating cutting tool, the surface produced is a horizontal flat (or plane) surface. Most of the work done in the shaper is of this description. The length of the stroke is set for approximately  $\frac{3}{4}$  in. longer than the work and the position of the stroke is such that  $\frac{1}{2}$  in. of this extra length comes at the beginning of the cut, to

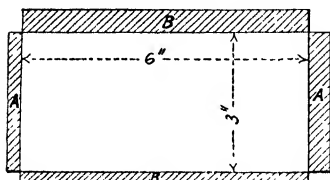


Fig. 2-36.

allow the tool block to seat properly for the next cut. If a given piece may be machined either crosswise with a short stroke or lengthwise with a longer stroke, other things being equal, it is better to take the longer stroke. To shape, for example, a piece  $3 \times 6$  in., twice as much time will be wasted cutting air when cutting crosswise as when cutting lengthwise. This is illustrated in Fig. 2-36 where the shaded portion *B* shows air cut with cross stroke and *A* the air cut with the lengthwise stroke.

However, there is still another factor. You usually make fewer strokes cutting in the 6-in. direction than crosswise, because the strokes per minute are not necessarily in the proportion of 3 to 6 in. This becomes especially apparent in finishing.

All work, however, cannot be machined with a lengthwise stroke. It is often more convenient (and makes for better practice), when extremely heavy cuts are being taken and when the work has only a very small gripping surface, to set the vise jaws perpendicular to the ram and use crosswise strokes, shorter strokes. With this setup, the work is less likely to slip in the vise.

An important point in shaper construction and operation may be emphasized here. The shaper manufacturer takes the utmost care to have the clapper block fit the box. The bearing surfaces are scraped to provide the best of sliding fits with no shake, the axis of the hinge pin is exactly at right angles and consequently the block *hinges freely* in the box during the return stroke and is rigidly supported during the cutting stroke. The bearing surfaces should be wiped clean and a very little oil applied at least once a week. If the

bearings are allowed to become dry or gummed with old oil, or if for any other reason the block does not always seat properly, trouble will surely result.

The position of the operator is at the right front of the machine with the speed and feed changes within easy reach. A low stool should be provided. In order that the depth of cut, the action of the tool, etc., can be more readily observed, the cut is usually started on the right side (the side nearer the operator), the feed of the table is arranged to move the work toward the operator *on the return stroke*, and the left-hand tool is used.

The smaller pieces or any pieces that will tend to tip under the pressure of the cut are best held with the vise jaws at right angles to the thrust.

There is practically no difference in roughing steel or cast iron except the cutting speed. For roughing plane surfaces of either cast iron or steel, the tools illustrated in Fig. 2-1 may be used. They must be held in a suitable holder.

#### **PROCEDURE FOR TAKING A HORIZONTAL CUT**

1. Thoroughly clean the vise and remove all burrs by scraping.
2. Thoroughly clean the work and remove all burrs by filing.
3. Select a pair of parallels wide and long enough to have the work project above the vise jaws (see Fig. 2-37).
4. Place the work in the vise as shown in Fig. 2-37 and tighten securely.
5. Make sure that the vise jaws are set perpendicular to the ram (see Fig. 2-37).
6. Select a roughing tool ground to the form shown in Fig. 2-1, page 26.
7. Select the proper toolholder, if one is needed, set tool in toolholder, and clamp. Whether a toolholder is needed or not, clamp the tool (or toolholder) in a vertical position (Fig. 2-38) or pointing *very slightly* in a direction *away* from the work, so that if, by *any chance*, the tool moves owing to the pressure of the cut, it will move *away* from the surface instead of undercutting it, as shown in Fig. 2-39. *Note the directions of the arrows.*

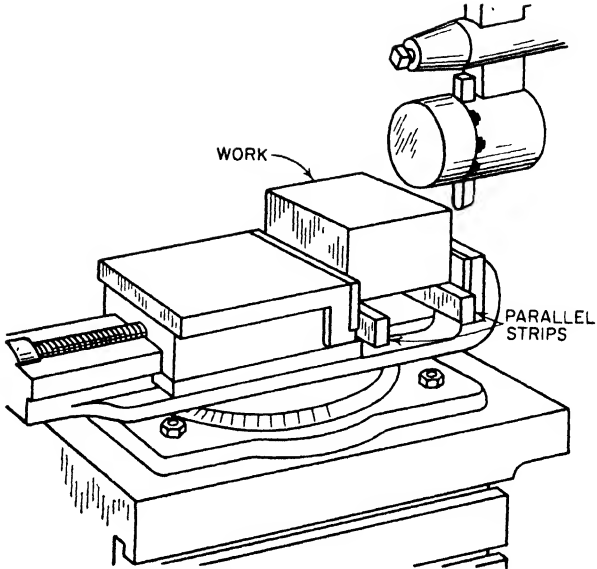
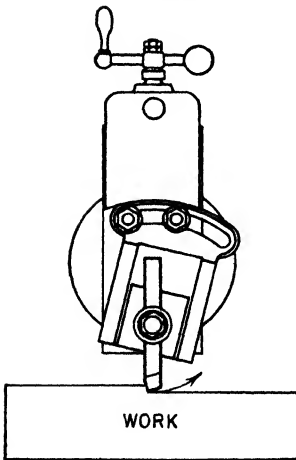


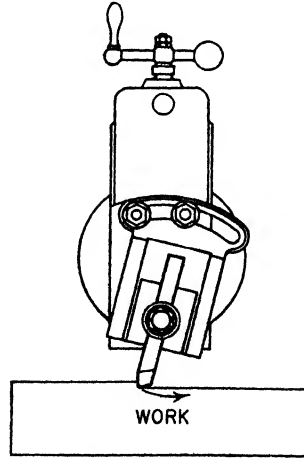
Fig. 2-37. Work in position for shaping.



RIGHT

TOOL WILL SWING OUT OF WORK

Fig. 2-38. The correct method of clamping a tool. (*The Cincinnati Shaper Company*)



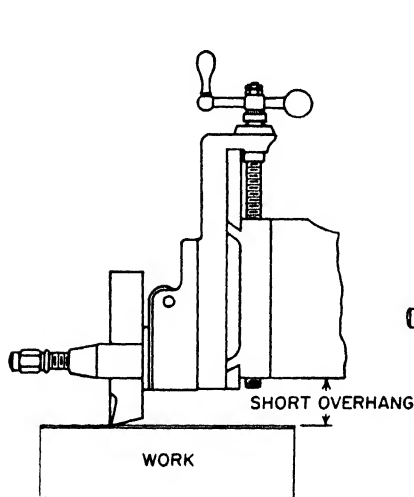
WRONG

TOOL WILL DIG INTO WORK

Fig. 2-39. An incorrect method of clamping a tool. (*The Cincinnati Shaper Company*)

8. Do not allow the cutting edge to project too far from the toolholder or the tool post—"catch it short"—and clamp it tight (Fig. 2-40).

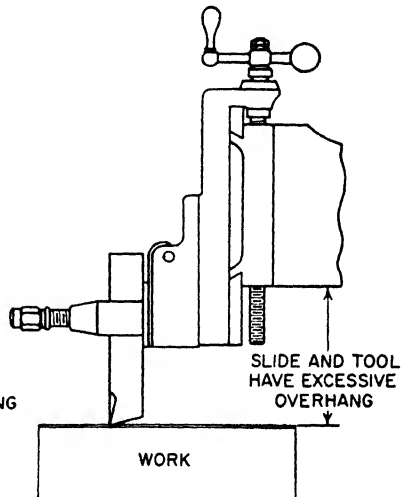
9. *Be sure the tool-head slide is not run down too far (Fig. 2-41), as this causes weakness and undue strain. It is much better to take*



**RIGHT**

KEEP SLIDE UP AND GRIP ON  
TOOL SHORT FOR RIGIDITY

**Fig. 2-40.** Correct amount of projection of the tool from the toolholder or tool post. (*The Cincinnati Shaper Company*)



**WRONG**

EXCESSIVE OVERHANG OF SLIDE AND  
TOOL MAY CAUSE CHATTER

**Fig. 2-41.** Incorrect amount of projection of the tool from the toolholder or tool post. (*The Cincinnati Shaper Company*)

*time to raise the worktable than to allow the toolslide to project below the head or have the tool project too far.*

10. Adjust the depth of cut to be taken by means of the downfeed handle.
11. Start the machine and feed the work by hand (cross-feed) until the cut is started, then, *and not until then*, throw in the power feed.
12. When the cut is completed, stop the machine and inspect the work.
13. If more stock is to be removed, repeat steps 10. 11. and 12.

When cast metals are being machined, the edge at the end of the cut should be beveled with a chisel or an old file about 45 deg., practically to the depth of the cut (see Fig. 2-42); otherwise chunks of the corner will break out below the surface, leaving the edge ragged.

Cast-iron scale is hard and gritty. Set the tool to take a chip deep enough *to get under the scale*. If during the cut a portion of the surface is low and the tool rubs on the scale, the cutting edge will very soon be ruined. Provided that it will not make the work undersize, take a deep chip, and if necessary reduce the amount of feed, but *get the roughing cut under the scale* if possible.

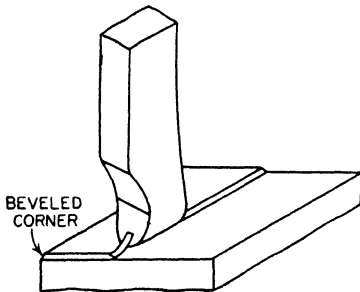


Fig. 2-42.

The finishing cuts should always be light. For finishing steel or wrought iron a fine feed will give the best result. A tool of substantially the same shape as the roughing tool, but with a narrower rounded end and a greater rake angle, produces an excellent finish; or if desired, the shear tool shown in Fig. 2-1, finishing tool, may be used.

The accepted commercial machine finish on flat cast-iron pieces of any considerable size is a surface that feels smooth and shows feed marks  $\frac{3}{8}$  in. or more apart. This finish is obtained by the scraping action of a broad square-nosed tool. This tool may be a forging, or the tool bit fitted to any one of a number of kinds of toolholders may be ground to shape. With a sharp tool, 0.002- to 0.004-in. chip, and  $\frac{3}{8}$  in. or more feed, a beautiful finish may be obtained. Use a slow speed and feed by hand. If the surface left by the roughing tool is badly torn, it may be necessary to take two cuts.

For finishing cast iron, the edge at the beginning of the cut should be filed slightly bevel so that the cutting edge of the tool will not strike the scale. Keep oil off cast-iron work; remember, even oily finger marks may defeat a good finish.

**Sharpening a Square-nose Tool for Finishing Cast Iron** (Fig. 2-43). Grind the front of the tool flat with 4- or 5-deg. clearance

and round the corners slightly, oilstone the top and set in the tool post as nearly correct as can be judged (cutting edge flat on surface to be finished). Place a sheet of heavy paper on the work and on the paper a good oilstone. The paper is to keep oil off the work. Raise the tool block, that is, hinge it forward, and bring the oilstone and the paper under the cutting edge of the tool. The tool block is now probably hinged forward 15 deg. or more; raise the slide until it only hinges forward a very little (about 4 deg.). Bearing lightly against the tool, rub the oilstone back and forth between the paper and the cutting edge. Lift the tool, that is, hinge it way forward occasionally, and note when it is oilstoned enough; then remove the oilstone and the paper, and allow the tool block to fall back into place. It is obvious that the tool is sharp and that the cutting edge is parallel with the work and has the proper clearance (about 4 deg.). Feed down carefully to the work and take a very light chip, a coarse feed, and a slow speed.

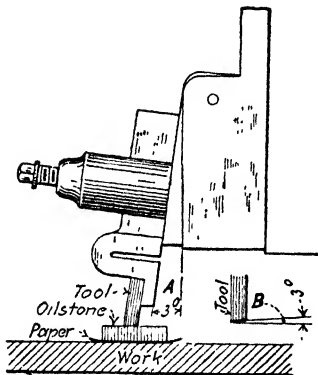


Fig. 2-43. If the tool is oilstoned when hinged forward, say 3 deg., as when at A, then, when it is seated, as during a cut, it will have a 3-deg. clearance, as shown at B.

**Setting the Head for Vertical and Angular Cuts.** The downfeed is used for vertical cuts, such as finishing the sides of tongues and grooves, squaring shoulders, squaring ends, cutting keyways, and occasionally for cutting off. It is used also for angular cuts, such as fairly wide beveled edges and ends, and for dovetails.

Except in the case of cutting off or a similar operation, or where the surface being machined is not much over  $\frac{1}{4}$  in. deep (or high) it is very necessary to swivel the apron when using the downfeed. This is illustrated in Fig. 2-44. When the top of the apron is moved in a direction *away* from the surface of the cut, the tool block and the tool will hinge in a direction up and *away from* the work during the return stroke. This is true in angular (bevel) cuts as well as vertical cuts (see Fig. 2-45).

The setup for an angular cut with the head swiveled and the apron



also set over sometimes appears awkward and wrong. It may help the beginner to imagine the angular cut as a vertical cut and set the

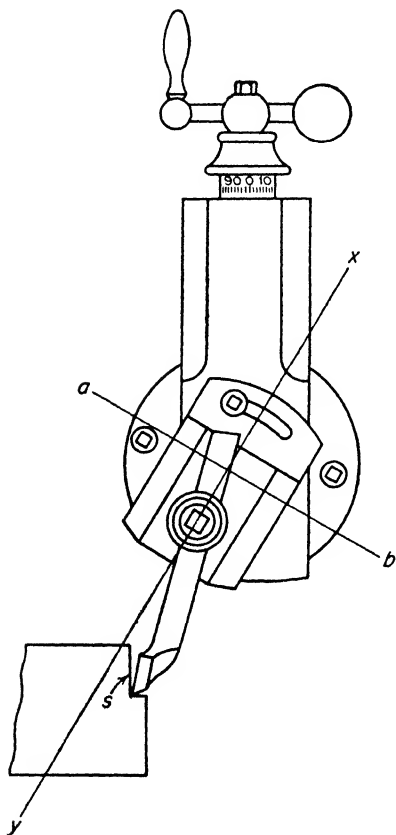


Fig. 2-44. Apron swiveled for a vertical cut. The axis of the hinge pin is in line with  $ab$ . The direction in which the tool block may rise on the return stroke is in a plane  $xy$ , at right angles to  $ab$ . If this plane is tipped away as illustrated, the tool will tend to raise in a direction away from the surface  $s$  and will not rub. If the plane is vertical, the tool will rub along the surface  $s$  on the return stroke.

apron accordingly. For all vertical or angular cuts it is important to understand and remember the following:

**RULE:** Always set the *top* of the apron in a direction *away from* the surface of the cut to be taken.

Although the construction permits of considerable downfeed of the head, it is not good practice to use the head with the slide run down much below the swivel plate, because in this position it is not so strong and rigid as when backed up by the ram. Sometimes it may

be advisable or even necessary, but in no other case than for a finish cut.

Be careful, when setting up, to have the slide high enough at the start for either a vertical or an angular cut, so that this weakness or this interference will not result during the cut.

**Shaping Vertical or Angular Surfaces.** A *vertical cut* is made in the shaper (or planer) by setting the head exactly on zero, arranging the apron so that the tool will clear the work on the return stroke, and feeding down.

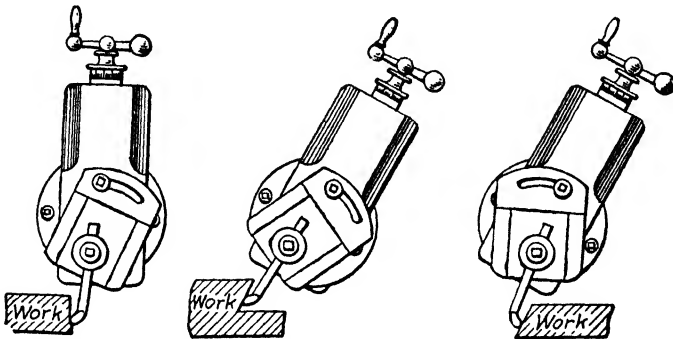


Fig. 2-45. Note that in each case the top of the apron is set over in a direction away from the surface being cut.

An *angular cut* is made by *swiveling the head* of the machine, arranging the apron so that the tool will clear the work on the return stroke, and feeding down.

It should be understood that it is not always necessary to take an angular cut to produce an angular surface. An *angular surface* is one that is neither parallel nor square to a given base or other surface. It may be machined in several ways:

1. The work may be supported on a tapered parallel (this is often called a taper cut).
2. A layout line indicating the position of the surface to be machined may be scribed on the work, and the work held in the vise with this line horizontal and the regular power feed used (for either taper or angle).
3. The work may be held in angular parallels (Fig. 2-17).

4. The vise may be swiveled to an angular setting.  
 5. Some shapers are provided with the universal table illustrated in Fig. 1-11.

6. The head of the shaper may be swiveled as shown in Fig. 2-45. Except for a downcut on a piece held in a vise which has been swiveled to a given angle (as in (4) above), all of the first five methods suggested require only the regular horizontal cut. The last method (5) involves the angular setting of the swivel head and is very properly called "an angular cut."

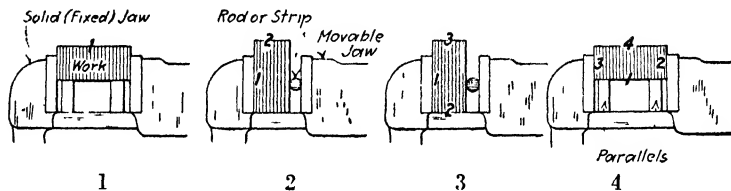
Attention is called to the setup of the shaper (or planer) for the downcut for producing either a vertical cut (*a*, Fig. 2-45) or an angular cut *b* or *c*, in the same figure.

### QUESTIONS ON SHAPER WORK I

1. What precautions should be taken regarding the vise jaws? Why?
2. What are parallels used for? How should they be cared for? Why?
3. Is it good practice to pound rough castings or forgings or bar stock down on parallels? How should they be protected?
4. What are "hold-downs" or "grippers"? How are they used? When are they used?
5. State four ways in which the vise may be "out" enough to cause inaccurate work.
6. Explain how you may test the work seat.
7. Explain how you may test the solid jaw.
8. How do you set the vise jaw *exactly* at right angles with the direction of the cut?
9. Why is it necessary, in order to do good work, to keep the vise jaws clean?
10. What causes a burr on the work? There are times when it is unnecessary to remove this burr. Explain. If you have several pieces, when do you remove the burrs?
11. How much longer than the length of the cut do you set the length of the stroke? Why?
12. How is the tool arranged in the tool post for a horizontal cut?
13. Frequently one sees the tool slide run down 2 or 3 in. below the head. What does this indicate? What is the remedy?
14. When taking a cut in cast iron, why should you, whenever possible, cut under the scale the first cut?

15. What is the proper way to take a finishing chip on cast iron?
16. Explain how to sharpen the square-nose tool for a shaper cut.
17. How does the clapper block fit the clapper box?
18. Are the bearing surfaces of the block and the box smooth and clean? When and how should these surfaces be cleaned and oiled?
19. How may the apron be swiveled? How much?
20. Explain how hammering the side of the apron may prevent the proper seating of the tool block.
21. Why is the clapper box made so it can be swiveled on the head?
22. What is the rule for setting the apron when taking a vertical cut or an angular cut? Why is this rule important?

**Shaping a Rectangular Block or Similar Piece Square and Parallel.** Machine one side, preferably one of the larger surfaces (1)

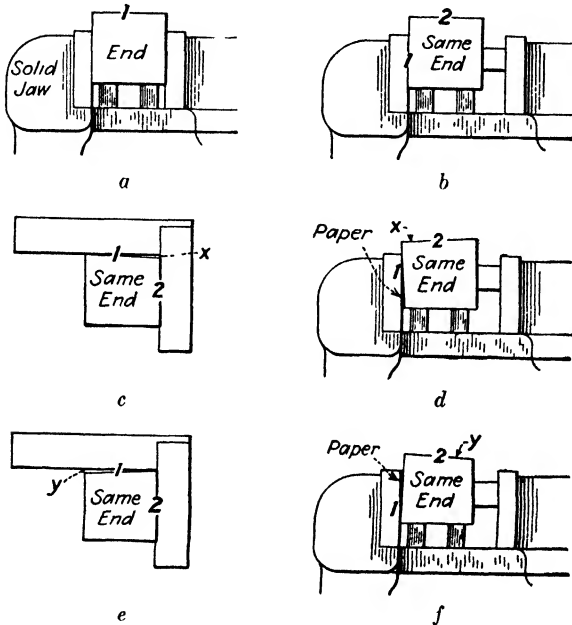


**Fig. 2-46.** The four successive steps in planing the sides of a rectangular block

in Fig. 2-46, then using this surface as a seat against the solid jaw, plane the adjacent side (or edge) (2). If the shaper vise jaw is square and smooth and if the surface first finished is clean and free from burrs and properly seated against the vise jaw, the second surface machined will be square with the first surface. In order to make sure that the surface first machined is properly seated against the vise jaw, it is customary to use a rod or strip between the movable vise jaw and the work. This will obviate any tendency for the work to change its position, owing to any "give" in the movable jaw.

Next, place the second finished surface down on the bottom of the vise, or on parallels if necessary, and the first surface against the solid vise jaw as before, with the rod or strip between the movable jaw and the work, and tighten the vise. With a babbitt hammer tap the work down in the vise to make sure that it is properly seated on the bottom, and plane surface (3). If the vise jaw is square and the tool is sharp and if care is taken to clean the surfaces of the finished

work from burrs and chips, the two edges just machined should be parallel, and both square with the first side machined. Now place the first machined surface down on suitable parallels, clamp the work between the jaws *without* the rod or strip, and with a babbitt hammer, tap (not pound) the work until it is properly seated. If the vise is true and the work is seated on both parallels so that neither



**Fig. 2-47.** The use of a paper shim. Suppose the cuts 1 and 2 are made as in (a) and (b), and tested with a square; if more than 90 deg. (shows light at *x*), shim along the bottom as in (d); if less than 90 deg. (shows light at *y*), shim along the top as in (f).

parallel can be moved, then it is obvious that the fourth surface will be parallel with the first surface and square with the other two sides.

It is better to seat the work on two parallels rather than on one, for the reason that it is easier to judge if the work is properly seated. Further, it may be desirable to measure the piece with a micrometer or caliper; this may be more readily accomplished if there is a space between the two parallels or between one parallel and the vise jaw.

*Adjacent Surfaces.* If a piece of work having one side machined is to have either or both adjacent surfaces machined square with this side, the work must be set up properly. If for any reason the work is not "square in the vise," the adjacent surface, when machined, will not be square with the surface already machined. If, for example, the solid jaw is "out of square" and the work tightened against the faulty surface, the work will be as much out of square as the vise jaw.

In testing the solid jaw of the vise, it was assumed that when the solid vise jaw is not square and true, time should be taken to correct the fault. This is not always possible; frequently it is advisable to shim the work in the vise rather than shim the vise jaw. This may be done, with paper usually, as shown in Fig. 2-47.

It is important to understand, further, that unless the *bottom* side is square with the side against the solid jaw, both of the parallels under the work will not be tight. This is shown in an exaggerated manner in Fig. 2-48. No amount of hammering will "squash" the steel and seat the work on both parallels when the work itself is out of square or when it is held out of square, but a few taps with the babbitt will seat the work on both parallels when conditions are right.

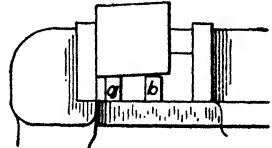


Fig. 2-48.

*Squaring the Ends.* The ends may be machined square in two ways, the shorter pieces by taking the cut horizontally across, and the longer pieces by cutting vertically downward. The short piece is set in the vise, either on the bottom of the vise or on a suitable parallel, and a finished edge or side set perpendicular by means of a machinist's square as illustrated in Fig. 2-49. Hold the square down hard on the parallel and the piece of work hard against the blade of the square and tighten the vise lightly. Check the setting, tap the work one way or the other if necessary, then tighten securely. If this is properly done, and the vise jaws clean and square, the end when machined should be square with the surfaces already machined. To finish the other end it is necessary merely to seat the work on the finished end, tap carefully with a babbitt hammer to make sure that it is seated, and finish to the length required.

If the work is too long to finish the ends in this manner, it may be set lengthwise in the vise, with one end projecting in a position to be

finished by a vertical cut. Use parallels to raise it substantially flush with the tops of the jaws and allow it to project from the end only a short distance. A forged tool like that shown in Fig. 2-50 may be used in this operation. Tighten the vise securely. Run the tool slide well up toward the top, swivel the apron, and adjust the tool. For the reason that the tool will probably have to project some little distance from the tool post in order to take the cut to the bottom of the piece without interference, a feed and chip somewhat lighter than for horizontal machining will be advisable. Care must be taken not to break out the corners at the end of the cut if cast metal is being machined. An excellent finish may be obtained on cast iron with a

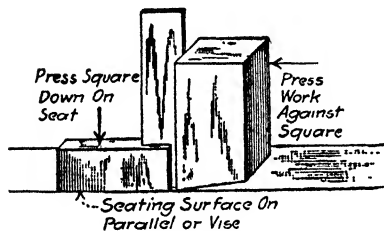
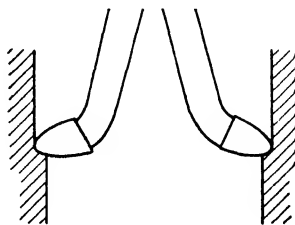


Fig. 2-49.



DOWNCUTTING

Fig. 2-50. A down-cutting tool.

side tool; have about  $\frac{1}{4}$  in. of the cutting edge ground straight and set vertically; take a very light chip and a half turn of the downfeed screw for feed.

**Shaping an Irregular Cut.** A narrow irregular surface may be finished very efficiently with a forming tool. It will be better to hold the forming tool in a toolholder. Even if only a few pieces are to be shaped, it will probably be worth while to make a suitable forming tool. When machining a wider irregular cut, it usually is customary to lay out the irregular shape on the end of the work and machine to this line. When shaping an irregular piece to such a line, it is a good plan to rough to within a  $\frac{1}{16}$  or  $\frac{1}{32}$  of the line and then with a file bevel the edge to the line at an angle of 45 deg. or more, as illustrated in Fig. 2-51. With a suitable tool, with a round nose if convenient to use, machine off the bevel. If the bevel only is removed, then the surface is finished to the layout line. It is easier to see the bevel and gage the cut than it is to split the line without the bevel. When machining

a wide irregular cut of a curved outline, the vertical *hand feed* may be employed in connection with the *power table feed*. It is easier and better to feed down than up; therefore, start at the highest part, feed

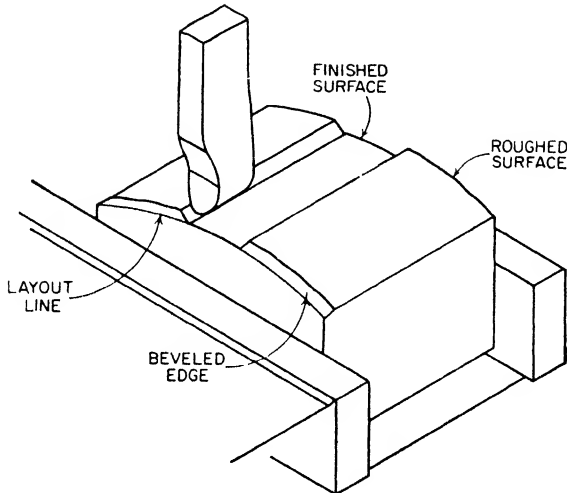


Fig. 2-51.

down by hand, and feed the table in the desired direction, either by hand or by power, usually by power.

**Shaping Tongue and Groove.** In nearly all cases where such operations as tongues and grooves (Fig. 2-52) or dovetails (Fig. 2-60)

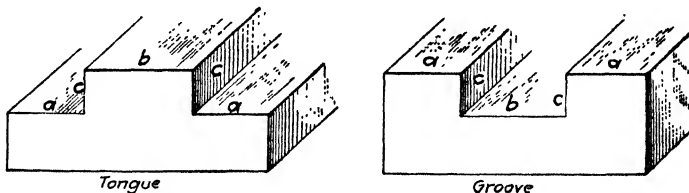


Fig. 2-52.

are to be made, a base surface is assumed to be finished. Also the surface where the tongue or groove or dovetail is to be cut is roughed to within  $\frac{1}{32}$  in. The other surfaces are usually machined square with the base surface at the same time if they are ever to be machined. Assuming that these surfaces are already machined, proceed



with the tongue or the groove, whichever is preferred. The tongue is considered easier because there is more room for the tool.

When shaping tongues and grooves or other shoulder operations, the roughing cuts should be made fairly close to the dimensions required, using the regular shaper tool with a small radius wherever convenient. When finishing, the surfaces *a* and *b* (Fig. 2-52) are machined to the degree of accuracy desired, but on each of these sur-

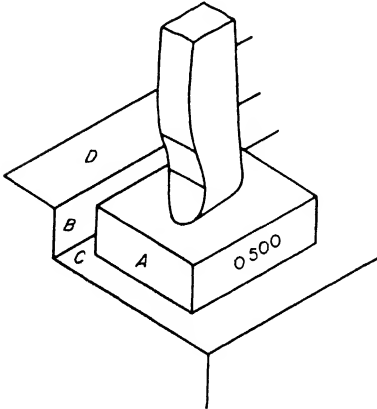


Fig. 2-53. Use of size blocks, *A*,  $\frac{1}{2}$ -in. size block; *B*, shoulder; *C*, finished surface; *D*, surface to be finished  $\frac{1}{2}$  in. from *C*.

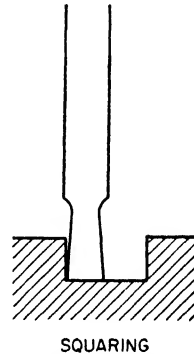


Fig. 2-54. A squaring tool.

faces there is usually left a thousandth or two for the fitter to file or scrape off. For the distance from the surface *a* to surface *b* the graduations on the downfeed screw may be accurate enough, or if desired a size block (Fig. 2-53) may be used.<sup>2</sup> If the work is cast iron, the tool illustrated in Fig. 2-54 may be used for finishing all the surfaces *a*, *b*, and *c*. If the work is steel, the finishing tools for the corners (and also for the bottom surfaces) may be shaped like (1) and (2) in Fig. 2-55. The cutting edges for side and bottom are represented by *x* and *y*, respectively. These tools are given 15- or 20-deg. side rake.

<sup>2</sup> A set of gage blocks or "size blocks" is of great value to gage the setting of the tool for shoulders or similar projections. Gage blocks of any desired size, hardened, ground, and lapped for extreme accuracy, may be purchased, but for ordinary shaper work a piece of cold-rolled steel of the required thickness will answer.

Many machinists prefer to finish the smaller shoulder cuts in steel as well as in cast iron with a square-nosed tool without rake (Fig. 2-54). This saves changing tools and is satisfactory for small jobs and light cuts.

*Horizontal Surfaces of Tongue and Groove.* To finish the horizontal surfaces, proceed as follows:

1. If the shoulder is under  $\frac{1}{2}$  in. high, use a square-nose tool and have the apron in normal (vertical) position. Be sure the tool is properly ground and set "square."
2. If the shoulder is over  $\frac{1}{2}$  in. high and the right- and left-hand shoulder tools are used, have the apron "set over" in the right direction and then set the tool square.

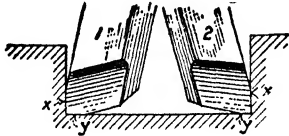


Fig. 2-55. Tool bits for finishing square-shoulder cuts. Surfaces  $x$  and  $y$  are at an angle of 90 deg. or a trifle less.

3. When using the graduations on the downfeed for gaging the vertical distance, first machine the top surface of the tongue ( $b$  in Fig. 2-52) to the finish size, then run the tool down the right distance and finish surface  $a$ , beginning at the edge and feeding toward the center. Both surfaces  $a$  may be finished with one setting of the tool.

4. When using a size block (Fig. 2-53) to gage the vertical distance, first machine surfaces  $a$ , then set the tool by the size block, and finish surface  $b$ .

5. When shoulder tools are used it will, of course, be necessary to reset the apron and change the tool to machine the second surface  $a$ . In this case, set the second shoulder tool to touch tissue paper on the finished surface and machine the second surface exactly in line with the first.

*Vertical Surfaces.* 1. When a vertical surface over  $\frac{1}{2}$  in. high is to be finished, it is usually necessary to set over the apron to allow the tool to clear the work on the return stroke; it is advisable to do this even when finishing the horizontal cut to a fairly high shoulder.

2. For the smaller jobs, say a tongue not over  $\frac{1}{2}$  in. high, the square-nose tool in Fig. 2-54, page 68, may be used for all surfaces (no setover of the apron is needed).

3. For the larger jobs the shoulder tools (Fig. 2-55) are best. Set over the apron according to the rule on page 61.

4. Whichever tool is used, first cut away (with this tool and hand feed) most of the fillet left by the round-nose tool when roughing. Then finish the vertical surface to the layout line, or to measure or gage if advisable, and feed down to the horizontal line.

5. To finish the second vertical surface if the apron has been set over for the first, reverse the position of the apron and change the tool.

6. If the square-nose tool is used without setting over the apron, merely run the tool up and over to the beginning of the other vertical surface and machine down to make the tongue the correct size.



Fig. 2-56. Adjustable parallels.

*Shaping the Groove.* Instructions for shaping the groove are similar to the above for shaping the tongue except for the roughing cut. To rough the groove proceed as follows:

With a cutting-off or similar tool, cut slots *inside* the layout lines for the groove, one slot on each side nearly to the bottom of the groove. Then cut away the metal remaining between the slots, possibly with the tool just used if only a small amount of stock is left. This will leave the groove roughed out nearly to the layout lines.

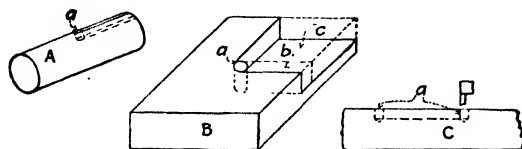
When finishing the bottom of the groove with shoulder tools (Fig. 2-55), finish half or more with one tool and the remainder when the apron is reset and the tool changed.

*Taper Parallels or Adjustable Parallels* (Fig. 2-56). These parallels are useful in gaging the width of a slot or a groove; slip one past the other until the slot is filled, then measure over the two with a micrometer. Possibly in a wider groove a straight parallel may be necessary to help fill the width of the groove.

**Shaping Slots, Keyways, Etc.** A keyway tool looks like a short cutting-off tool and has the same clearance angles. For shaping slots, keyways in shafts, or similar cuts, the average 14-in. shaper will carry a tool  $\frac{1}{4}$  in. wide in steel or cast iron, provided a fairly light chip—0.005 to 0.010 in.—is taken. For a wider slot, two cuts or more may be necessary. If more than two cuts are necessary, take the out-

side cuts to (or splitting) the layout lines, then remove the metal left between.

*Taking Cuts Which End in the Metal.* When making a cut which terminates in the metal (Fig. 2-57), it is necessary to drill a hole, and

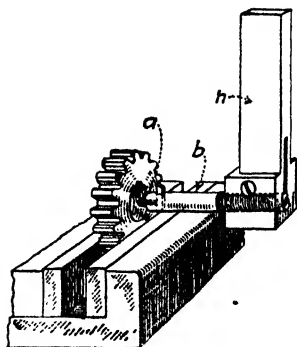


**Fig. 2-57.** In *A*, the diameter of the drilled hole (*a*) equals the width of the keyway. In such a job as *B*, first drill a hole at (*a*), say  $\frac{1}{4}$  in. in diameter; next, machine the slot (*b*); then machine the remainder (*c*), the cut ending in slot (*b*). Such a job as *C*, requires a drilled hole at the beginning and also at the end of the keyway. Keyways such as those shown in *A* and *C* are cut more easily in the milling machine, but occasionally must be cut in the shaper or the planer.

in wide cuts to machine a groove, at the end of the cut, for the reason that if the chips are not cut off, they will remain to clog the cut and soon break the tool. Occasionally it is required to machine a groove, a keyway for example, somewhere between the ends of a rod or shaft (*C*, Fig. 2-57). In such a case, holes should be drilled at the beginning and end of the slot.

**NOTE:** Modern shapers are constructed to permit the end of a shaft to extend beneath the ram as far as desired.

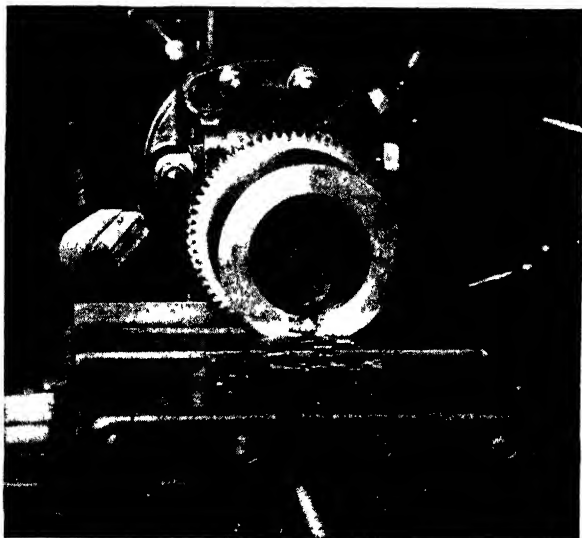
*Shaping Keyways.* It is often convenient to use a shaper to cut keyways in the hubs of pulleys, gears, etc. A forged tool for this purpose is not economical and is not much used. Figure 2-58 shows a homemade keyway tool-holder that works well. The tool point is held in the bar *b* by a setscrew *a* at the end. The thread on the bar screwing into the holder *h* helps materially in holding. Bars of various lengths may be used. It is much more efficient to set up the work with the layout on *top* and feed *up* because of the tendency otherwise for the tool to chatter and jump.



**Fig. 2-58.** Planing a keyway in a gear (see also Fig. 2-59).

If the diameter of the work to be keyseated is fairly small, use a short bar  $b$  and let the tool post travel back and forth over the top of the work. That is, while the toolholder  $h$  is not caught especially short in the tool post, this lack of rigidity is more than made up for by the shorter bar.

If the diameter of the work is so large that the tool post cannot move back and forth over the blank, the bar will have to project far



**Fig. 2-59.** Cutting a keyway in a ring gear. (*The Cincinnati Shaper Company*)

enough in front of the tool-post screw to go through the hole. In this case catch the tool short.

Notice that the diameter of the bar in Fig. 2-58 is smaller than the diameter of the hole. This is because the tool bit projects and both the bar and projecting bit must go through the hole.

It frequently happens, when work is held in the shaper vise as shown in Fig. 2-58, that the ram will not go back far enough. In such a case do one of three things: (1) Put one or more parallels, as high as the vise jaw, back of the work and clamp the work between the parallels and the movable vise jaw. (2) Clamp the work in a plain

vise (milling or drill press) and then clamp this vise in the desired position in the shaper vise. (3) Remove the shaper vise and clamp the work to an angle plate.

The tool bit for keyseating is quite small and must be very carefully ground. The cutting edge must have clearance in order to cut, and the sides also must be backed off a little; otherwise the tool will rub. Only a very little clearance is needed. To avoid any tendency to have the top of the keyseat wider than the bottom, the cutting edge of the tool should be the widest part, but only a trifle wider; use a micrometer and be careful. Give the tool very little, if any, front rake, and no side rake.

The layout for a keyseat takes only a few moments and is usually done at the time the keyseat is made by merely scribing a radial line, using the center square. If advisable, in addition, to lay out the full width of the keyseat, it may be done quickly in the shaper vise, using a flat square and a scale. However, if several pieces are to be scribed, the full width of the keyseat, it will be best to do the layout work before setting up the machine.

Most keyseats that are machined in a shaper may be made with a full-width tool bit. Draw a radial line indicating the center position of the keyseat. Grip the work lightly at first, and, with a square, set the radial line perpendicular. Then tighten the work securely.

After properly setting the tool, adjust the worktable until the radial line is central with the tool. Take one stroke of the shaper by hand to be sure that there is no interference. When the tool touches the work, set the graduations at zero and feed the required depth. On account of the springy nature of the tool, use a fairly slow speed and do not feed over 0.010 in. per stroke.

If the keyseat is too wide for one cut, it is best to lay out the sides of the slot to be cut, and cut to the lines. Possibly two cuts will make a satisfactory job, but often it is advisable to make three cuts—a full-depth “stocking” cut near the middle, and a finish cut to each line.

**Shaping Dovetails.** A dovetail slide bearing is illustrated in Fig. 2-60. To shape a dovetail calls for operations which are very similar to cutting a tongue and groove. If the student has not already cut a tongue and groove, his attention is called to information in detail

given in the paragraphs covering the shaping of tongue and groove, the horizontal surfaces of tongue and groove, the vertical surfaces, and shaping the groove, pages 67 to 70.

Refer to the drawing to note if other surfaces than the dovetail are to be machined, and if so, machine them first. Finish the base surface, for the reason that it is easier to lay out and work from a finished base or working surface. Then machine the other surfaces to within, say,  $\frac{1}{32}$  in. of the finished size. It is best to leave about  $\frac{1}{32}$  in. on both sides until after the dovetail is cut; then the sides of both the base and the slide may be easily finished in exact relation to the dovetail.

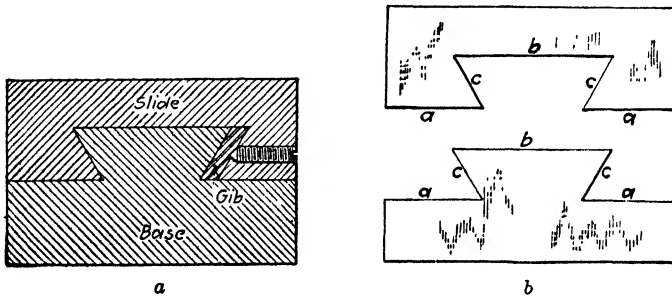


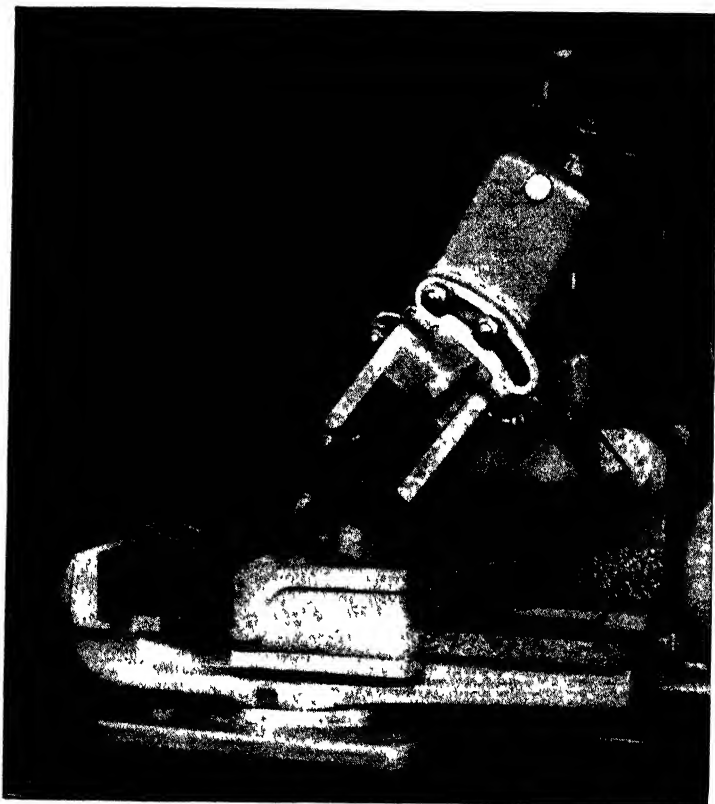
Fig. 2-60. Dovetail slide bearing.

Whether it may be advisable to *rough* one angle and then turn the piece end for end and rough the other angle will depend upon the job. It will save time of changing the tool and the setover of the apron, if practicable. It is not considered good practice to *finish* a dovetail by cutting one angle and then turning end for end; when one part of the dovetail is finished, the work should not be disturbed until the whole dovetail is finished.

The chief difference in shaping the tongue and groove and the dovetail is in the shaping of the surfaces *c* (Fig. 2-60). These surfaces, being angular, call for the setover of the *swivel head* of the shaper, also the setover of the *apron*, and for at least one pair of undercutting tools. The shape of the tools is illustrated in Fig. 2-61. A setup is shown in Fig. 2-61. If considerable metal must be removed, it will probably need a roughing and finishing tool for each side.

**CAUTION:** Do not run the ram back into the column with the slide at an angle.

Assuming the base and sides are already finished, or at least squared up, the surfaces *b* in Fig. 2-60 and the greater part of the

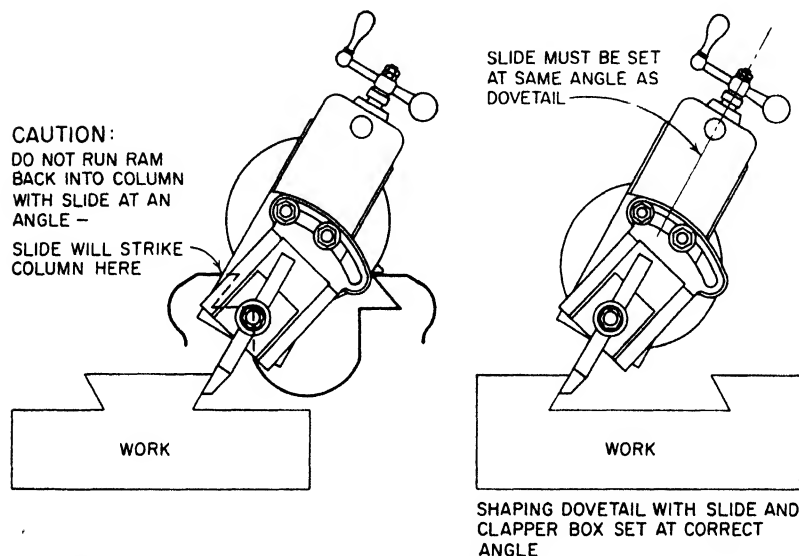


**Fig. 2-61.** Shaping a dovetail. (*The Cincinnati Shaper Company*)

surfaces *a* should be roughed practically as for tongue and groove, and, without the setting of the work's being disturbed, the surfaces *c* and the portion of the surfaces *a* under the overhang may then be roughed. The finishing operations are made in the same order. The tool that is used for finishing surface *c* may be properly used for sur-



faces *a* and *b*, provided that the tool is not too slender and the surface is not too large. The beginner should pay particular attention to the swivel of the apron. Remember that when *not* properly set it may appear all right, and therefore be *very sure* that the *top* of the apron



**Fig. 2-62.** Position of the slide when cutting a dovetail. (*The Cincinnati Shaper Company*)

is set in a direction *away* from the surface being finished. Study Fig. 2-62 very carefully for setting the slide.

**Measuring Dovetails.** Probably the greatest difficulty in producing dovetails is in measuring them. When a *gib*<sup>3</sup> is used between two of the sliding surfaces as great a degree of accuracy is not re-

<sup>3</sup> *Gib.* In machine construction a piece of metal arranged to provide an adjustment for a bearing. In *a*, Fig. 2-60, is shown a cross section of a *straight gib* between two bearing surfaces and adjusted by a series of screws. Frequently *taper gibs* are used, and the dovetail in the base is made correspondingly wider at one end. Such a gib is adjusted lengthwise to take up the wear in the bearing surfaces.

quired in machining as when the two pieces fit together. In either case, however, a smooth cut is necessary, a thousandth or two should be left for scraping, and care must be taken not to "leave too much," and certainly not to "take off too much." It is good practice to lay out the dovetail and, if possible, it should be scribed on a surface that has been finished. If several pieces are to be machined, it will be advisable to make a template of sheet metal  $\frac{1}{8}$  to  $\frac{1}{4}$  in. thick to use for laying out and possibly as a gage.

The table given below should prove helpful in making accurate measurements of dovetails to find how much more it may be necessary to shape an angular surface and also to check the finished product. It consists of a series of fixed values for determining the measurements for various angles of dovetails when using various sizes of drill rod.

At first glance the table may appear rather difficult, but its use involves only addition, subtraction, and multiplication of decimals. In principle it is similar to the three-wire method of measuring threads and its application is just as easy.

#### Measuring Dovetails with Pieces of Drill Rod

In the table,  $R$  is the diameter of the drill rod and the values of  $D$  and  $F$  have been calculated as follows:

$$D = R \left( \cot \frac{\angle a}{2} \right) + R. \quad F = 2 \cot \angle a.$$

Various diameters of drill rod, in.		Various values of angle $a$			
		45°	50°	55°	60°
$R = \frac{1}{4}$	$D =$	0 853	0 786	0.730	0 683
$R = \frac{3}{8}$	$D =$	1 280	1 179	1.095	1.024
$R = \frac{1}{2}$	$D =$	1.707	1.572	1.460	1.366
$R = \frac{3}{4}$	$D =$	2.562	2.358	2.190	2.049
	$F =$	2.000	1 678	1.400	1.155

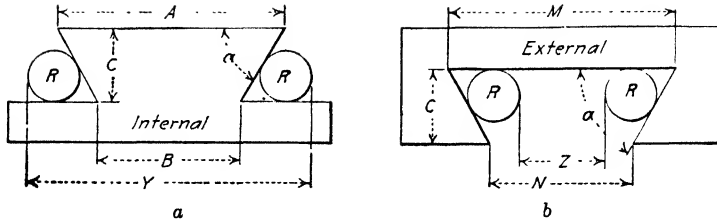


Fig. 2-63. Measuring internal and external dovetails.

### RULES

#### Internal

CASE 1: When the dimension  $B$  is given on the drawing.

$$Y = B + D$$

EXAMPLE: Angle  $a = 60^\circ$ ,  $B = 2\frac{1}{2}''$ . Using  $\frac{1}{2}''$  drill rod, what should  $Y$  measure?

SOLUTION:  $Y = 2.5'' + 1.366'' = 3.866''$ .

CASE 2: When the dimension  $A$  is given on the drawing it is necessary to find dimension  $B$  before proceeding further.

$$B = A - CF$$

EXAMPLE: Angle  $a = 60^\circ$ ,  $A = 3''$ ,  $c = \frac{3}{4}''$ . Using  $\frac{1}{2}''$  drill rod, what should  $Y$  measure?

SOLUTION: First find dimension  $B$  thus:  $3'' - 0.750'' \times 1.155 = 3'' - 0.866'' = 2.134''$ .

Then  $Y = 2.134 + 1.366 = 3.5''$ .

NOTE: The measurement of  $Z$  may be made with adjustable taper parallels placed between the rods (see Fig. 2-56).

#### External

CASE 1: When the dimension  $M$  is given on the drawing.

$$Z = M - D$$

EXAMPLE: Angle  $a = 60^\circ$ ,  $M = 3''$ . Using  $\frac{1}{2}''$  drill rod what should  $Z$  measure?

SOLUTION:  $Z = 3'' - 1.366'' = 1.634''$ .

CASE 2: When  $N$  is the dimension given on the drawing it is necessary to find dimension  $M$  before proceeding further.

$$M = N + CF$$

EXAMPLE: Angle  $a = 60^\circ$ ,  $N = 2''$ ,  $c = \frac{3}{4}''$ . Using  $\frac{1}{2}''$  drill rod what should  $Z$  measure?

SOLUTION: First find dimension  $M$  thus:  $2'' + 0.750'' \times 1.155 = 2'' + 0.866'' = 2.866''$ .

Then  $Z = 2.866'' - 1.366'' = 1.5$

**Vertical Shaper.** The vertical shaper (Fig. 2-64) is much used in general machine shops and toolmaking departments. The worktable with longitudinal, transverse, and rotary feeds, both hand and power, gives certain advantages; for example, a variety of power-fed cuts, straight and curved, with the layout lines always in plain sight of the operator.

The construction of the vertical shaper has many points in common with the standard (horizontal) shaper. The operation of the two

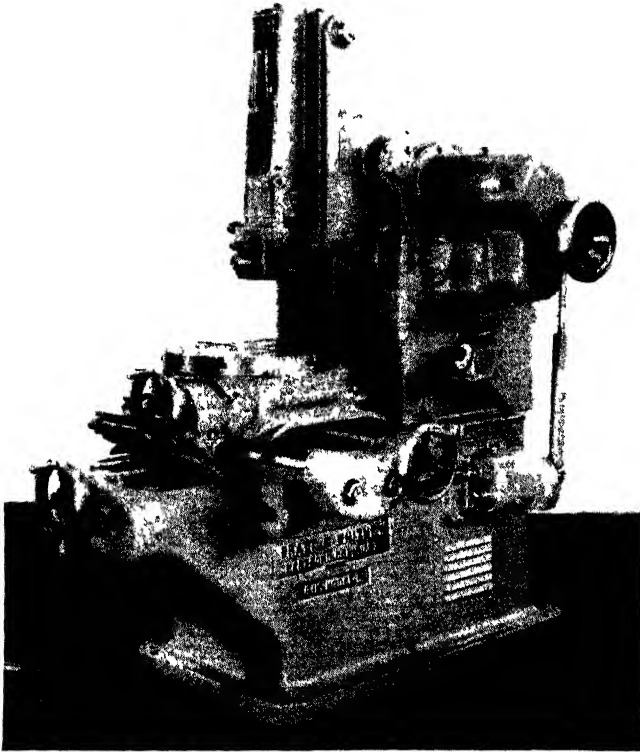


Fig. 2-64. The vertical shaper (*Prall & Whitney Company*)

types is very similar as to tools used, feeds, speeds, layout, and measurements.

### QUESTIONS ON SHAPER WORK II

1. Given a rectangular block, say, 2 by 6 in. and 1 in. thick, which side should you machine first? Which side will you machine next?
2. After machining the first surface, what objection is there to machining the opposite surface next?
3. Why is the surface that has been machined placed against the solid jaw of the vise?
4. Why is a strip placed between the movable jaw and the work?

5. When machining the third (and fourth) surfaces the use of two parallels, as far apart as convenient, is advisable. Why?
6. How does the arrangement suggested in the preceding question aid in making accurate measurement?
7. How are the ends machined when the piece is short? When the piece is over 6 or 8 in. long?
8. How is short work adjusted in the vise to make sure it is square when machining the ends?
9. Is a coarse feed or a fine feed used in finishing a cast-iron surface in a shaper? For finishing steel?
10. What kind of tool is used for finishing cast iron? For steel?
11. In machining cast metals, what precautions should be taken to prevent the metal breaking out at the end of the cut?
12. Why is it necessary to get under the scale when cutting cast iron?
13. What is a forming tool? Why is a spring toolholder excellent for holding a forming tool?
14. How is a comparatively narrow irregular surface planed?
15. After a wide irregular surface has been roughed out how is the edge beveled? What is the object of the bevel?
16. What kind of tool is used for finishing the sides of a tongue? The horizontal surfaces?
17. How may the groove be accurately and quickly measured?
18. Strange as it may seem, the cutter for keyseats works better up than down. How do you account for this?
19. When required to cut a keyway in a shaft a certain distance why do you first drill a hole at the end of the keyway?
20. What tool is used for finishing the angular surface of a dovetail?
21. State two distinct operating advantages of the vertical shaper.

# *The Planer*

---

## CHAPTER 3

---

### **Planer Construction**

The function of the planer is the production of flat surfaces on work that is impracticable to machine in the milling machine or too large to machine on a shaper. The work is fastened on the worktable, or "platen," which has a reciprocating motion past the tool head. The tool cuts only on the cutting stroke of the platen (as it moves toward the rear of the machine) and is held stationary except for the feeding movement. The feed may be in a horizontal direction across the top of the work, by reason of the movement of the tool head along the crossrail, or in a vertical or angular direction through the downward movement of the tool-head slide. The operation of the feeds will be explained later.

The single-point cutting tool produces a more accurate surface and one that is much better adapted to the scraping operation than a milled surface. Each of the standard machines in the shop has its particular advantages, and while the larger sizes of milling machines have taken the place of the planer in certain classes of work, they cannot compete with the planer in the production of flat surfaces that must be finished smooth and true. For example, such machine-tool parts as lathe carriages, the bases of headstocks and tailstocks, the sliding surfaces of shaper columns and rams, also shaper tables, worktables of grinding machines, milling machines, etc., are planed. For the bases, frames, and heavier sliding parts of such machines as steam engines, locomotives, printing presses, and rolling-mill, woodworking, and textile machinery, etc., the planer is indispensable.

The general run of planing is a more accurate flat-surface work and calls for a high degree of skill. Planer work should prove very

interesting. First-class planer hands are hard to find and, consequently, are among the best-paid mechanics in the trade.

To be able to handle a planer, the operator should understand, first, the general construction of the machine, especially the driving mechanism, the feed mechanism, the tool head, and the adjustment of the crossrail which carries the tool head; second, the various methods of clamping the work, which operation, on the planer, probably calls for more skill than in any other machine-shop tool; third, how to obtain the best and most efficient cutting action of the tools.



**Fig. 3-1.** A modern hydraulic planer with three heads. (*The Rockford Machine Tool Company*)

The difference in handling the various types and sizes of planers is, for the most part, in the degree of experience and skill required for the given job. As a matter of fact, some of the most exacting and interesting work is done on the smaller planers.

With few exceptions, all broad flat surfaces—particularly those having sliding contacts—are work for the planer. Work that is built up of parts bolted together, where good alignment is necessary, comes within the planer's field, too.

Planing is also the best method of finishing long, thin work that must be free from chatter or that would be distorted by local heat-

ing, as in milling or grinding. The planer tool distributes the heat evenly and rapidly and does not distort the work.

A modern four-head planer having hydraulic-drive and -feed mechanisms is shown in Fig. 3-1. References in this chapter apply more particularly to the standard gear-driven planer. Hydraulic power transmission for machine tools is discussed in Chapter 15, pages 503 to 539.

**Parts of the Planer.** In order to understand certain necessary descriptions which follow, it will be advisable for the beginner to become familiar with the names and functions of the planer parts.

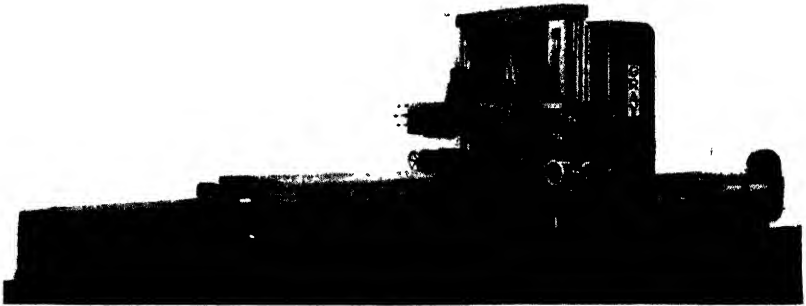


Fig. 3-2. A heavy-duty double-housing planer with four heads, two vertical and two horizontal. (*The G. A. Gray Company*)

In a general way, the names and descriptions given in the following pages apply to any standard planer of whatever make (see Fig. 3-3).

**Size of Planer.** Planers are classified as to size by the distance between the housings, the distance between the platen and the crossrail at its highest position, and the maximum stroke. For example, the machine tool illustrated in Fig. 3-2 is 48 by 48 in. by 14 ft. and is called a *heavy-duty double-housing planer*.

The smaller planers have only one tool head each; the larger planers have two heads apiece, with independent feed screws. Planers 28 in. wide and over may be provided with a sidehead mounted on the face of each housing. In such planers the finished faces of the housings are long enough to permit of the sideheads' being run down below the top of the table.

Perhaps a larger range of sizes obtains in planer manufacture than in any other machine tool except the lathe, but fortunately, in the



planer, as in the lathe, the principles of construction and operation are practically the same for any size.

**Openside Planer.** The value of the openside planer (Fig. 3-3) consists in its adaptability for planing parts much wider than would pass between the housings of a regular planer of equal size. For ordinary duty, it is not meant to supersede the regular type, but it is a practical machine for the purpose for which it is intended.

The openside planer, with one column, has been designed to give sufficient strength and rigidity to resist the severest twisting forces to which it may be subjected. Vertically adjustable on the side of the column is the knee, which, when set in position, may be rigidly locked. The massive column construction, together with the strength and stability of the knee, affords a support for the crossrail that prevents deflection under the heaviest cuts.

A steel hold-down gib, full length of the platen, runs in a flood of oil under a flange in the bed, to prevent any side-tipping of the platen caused by the weight of the overhanging part of a heavy casting. Also, a floor rest for supporting really wide pieces is made and furnished as an extra. When this is used, the overhang of the work is fastened to the rest which moves back and forth on an auxiliary rolling table.

**Modern Planers.** The large standard and openside planers have many advanced features of construction, such as: rapid traverse of any head in either direction; positive dial-set feeding mechanism for all heads, from 0 to 1 in. feed in increments of  $\frac{1}{64}$  in; special motor-driven rail-setting devices; double-length bed to eliminate overhang of the platen; safety clutches to prevent the feeding of any head too far, or of one head hard against the other; centralized and forced positive lubrication, with filtered oil, of all bearings; and the balanced helical-gear drive from the motor shaft to the table rack. A modern four-head gear-driven planer is shown in Fig. 3-2.

In the smaller planers improvements in design are also apparent. They have more rigid construction all through, in bed, housings, platen, rail, and gears; improved oiling systems; and a refinement in many details of design and construction of the bearings, slides, screws, and gears, to meet the demands for higher-speed, quicker-acting machines.

A very considerable amount of fine, accurate work was done on

planers 50 years ago, but in modern machines *quality* may be produced *more easily and quickly*. The planer hand today has better machines, better tools, better working conditions, and he must be alert to take advantage of modern machines with their greater speeds.

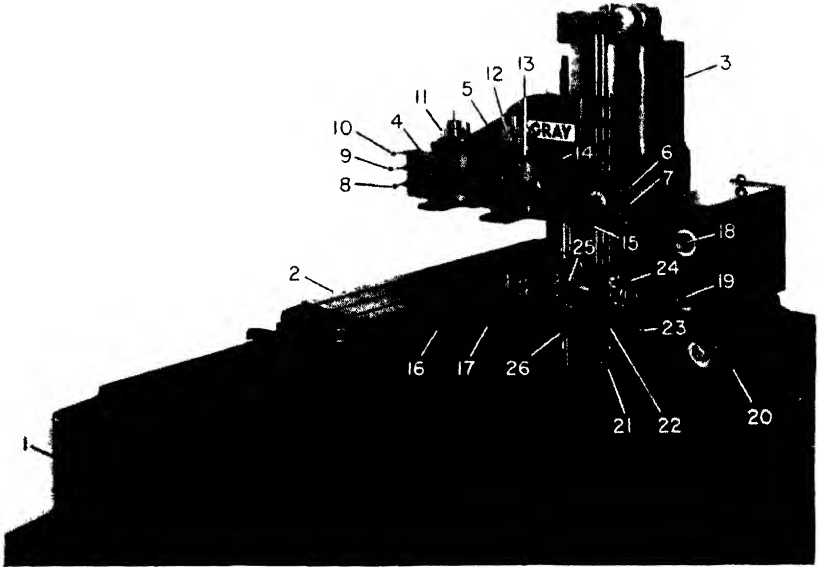
The cut stroke and the return stroke of the platen can be controlled by two rheostats. Most of the time the cut stroke is slower than the return stroke. However, some workpieces demand a cut stroke as fast as the return stroke.

You will also note that there are rapid-traverse controls for the various heads. This simply means that the heads may be brought into position or away from the cutting position faster by using these controls than by moving the heads by hand.

Another feature that many planers have is the tool lifter. This device is so arranged that when the return stroke is about to begin, the tool will be automatically lifted off the work, and thereby the rubbing of the tool on the work at this stroke is prevented. By the elimination of this rubbing action, the tool is kept sharp much longer and the amount of heat generated in the tool is considerably reduced. Tool lifters also prevent the chipping of carbide tools.

#### **Parts of the Planer (Fig. 3-3)**

1. *Bed*. Explained in a later section (page 87).
2. *Table, or platen*. Explained in a later section.
3. *Column*. Backbone of the machine; part to which rail and side-head are attached and clamped.
4. *Rail heads*. Parts on which the heads ride.
5. *Knee*. Part that contains the rail and is able to be raised or lowered.
6. *Knee- and rail-lock clamp*. Clamp that locks knee and rail to the column.
7. *Slide-selector lever*. Makes possible the choice of slide to be used in the operation involved.
8. *Feed and rapid-traverse control for R.H. rail head, cross-feed*. Controls the rapid traverse and feed of the right-hand rail head.
9. *Feed and rapid-traverse control for either rail head, vertical feed*. Controls the vertical feed for either the right-hand or left-hand rail heads.



- |  |   |
|--|---|
| 1. Bed   | 15. Feed-selector knob for rail-head feeds                      |
| 2. Table or platen   | 16. Front dog   |
| 3. Column  | 17. Master switch   |
| 4. Rail heads  | 18. Cut speed and selector knob                                 |
| 5. Knee  | 19. Return speed and selector knob                              |
| 6. Knee- and rail-lock clamp   | 20. Motor-generator set   |
| 7. Slide-selector lever  | 21. Tool-lifter engagement lever                                |
| 8. Feed and rapid-traverse control for R.H. rail head, cross-feed      | 22. Feed and rapid-traverse control for sidehead, vertical feed |
| 9. Feed and rapid-traverse control for either rail head, vertical feed | 23. Hand crank for vertical movement of sidehead                |
| 10. Feed and rapid-traverse control for L.H. rail head, cross-feed     | 24. Feed-selector knob for the side-head                        |
| 11. L.H. rail head   | 25. Sidehead  |
| 12. R.H. rail head   | 26. Saddle clamp  |
| 13. Slide clamp  |   |
| 14. Saddle clamp   |   |

**Fig. 3-3.** Parts of the planer identified. (*The G. A. Gray Company*)

10. *Feed and rapid-traverse control for L.H. rail head, cross-feed.* Controls the feed and speed of the rapid traverse of the left-hand rail head.
11. *L.H. rail head.* Head at the left side of the machine.
12. *R.H. rail head.* Head at the right side of the machine.
13. *Slide clamp.* Clamps the sidehead to the harp, which is fastened to the saddle.
14. *Saddle clamp.* Clamps saddle to knee.
15. *Feed-selector knob for rail-head feeds.* Knob used to set the amount of feed for the rail heads.
16. *Front dog.* Dog placed in position for the stroke.
17. *Master switch.* Limit switch controls movement of the table; operated by front and rear dogs.
18. *Cut-speed and selector knob.* Knob used to vary speed of table.
19. *Return-speed and selector knob.* Knob used to set the rate of the return speed of the table.
20. *Motor-generator set.* Motor-generator set used to supply direct current to the planer-drive motor only.
21. *Tool-lifter engagement lever.* Lever when engaged will lift the tool on the return stroke of the table.
22. *Feed and rapid-traverse control for sidehead, vertical feed.* Controls the feed and rapid-traverse engagement of the sidehead.
23. *Hand crank for vertical movement of sidehead.* Crank used to lower and raise the sidehead by hand.
24. *Feed-selector knob for the sidehead.* Knob used to set the feed for the sidehead.
25. *Sidehead.* Head holding the cutting tool; used for vertical cuts.
26. *Saddle clamp.* Clamps sidehead saddle to the column.

### UNITS OF PLANER CONSTRUCTION

**Planer Bed.** This unit, which is particularly heavy, is designed for strength and rigidity under great weight and heavy duty. The ways for the platen sliding surfaces are planed and scraped. They are automatically oiled under pressure through pipe lines from a reservoir or, in the older models, from oil wells suitably located. These wells should be filled every week and occasionally should be cleaned. The ways must be smooth and true if accurate work is to be

expected. Careless and ignorant operators frequently lose sight of this fact, and gritty dust and dirt are allowed to settle on the ways; in fact are often brushed into the ways. Be careful; remember that proper attention directed to the care of machinery marks the *real mechanic*, whether he is the operator or the superintendent.

**Platen Platen.** This is the unit that supports the work. It is provided with accurately finished T slots for the work-holding strips or fixtures and the necessary bolts. It is also provided with reamed holes for stops, poppets, etc. The platen is made of the best cast iron. For the sake of permanency in its finished shape it is rough-planed and then allowed to "season" a reasonable length of time before it is finish-planed and the sliding surfaces are scraped. To make for accuracy, the top is planed on its own bed before it is shipped.

The platen is *not* an anvil nor is it a suitable depository for half the bolts, clamps, and wrenches in the shop. The holes are accurately reamed to size and care should be taken to keep them round and smooth. Put a little oil on the stops or other planer "furniture" before you wring or tap them into the holes (never *hammer* them in). Two or three strips of old belting placed across the platen protect it during the placing of heavy castings. After the piece is in position it may be lifted, perhaps with a pry, and the belting may be removed.

**Crossrail.** The saddle and the tool head are carried by the crossrail. It is adjustable vertically on the finished front faces of the housings by means of two vertical screws, one in each housing. Both screws are moved an equal amount by turning a horizontal shaft arranged above the housings, motion of the shaft being transmitted through bevel gears to each screw at the same time.

The crossrail should be clamped rigidly to the housings when in use, and it is important to remember to loosen the clamps when adjusting for height.

The crossrail is of box-section construction, enclosing the feed rod for power downfeed and the feed screw for the regular cross-feed. Great care is taken to have the surfaces on the back scraped to an accurate flat bearing on the housings, and the surfaces for the saddle bearing perfectly fitted and parallel. The elevating screws are arranged to adjust the crossrail equally on each end, but for accurate work care must be taken that the rail when clamped is parallel to the platen.

To make sure the rail is parallel to the platen, lower it on suitable parallels arranged each side of the platen, and then clamp. Another way is to tighten an indicator in the tool post with the point touching the platen, and to note the reading as the head is run across the rail. Possibly one of the bevel (driving) gears will have to be readjusted.

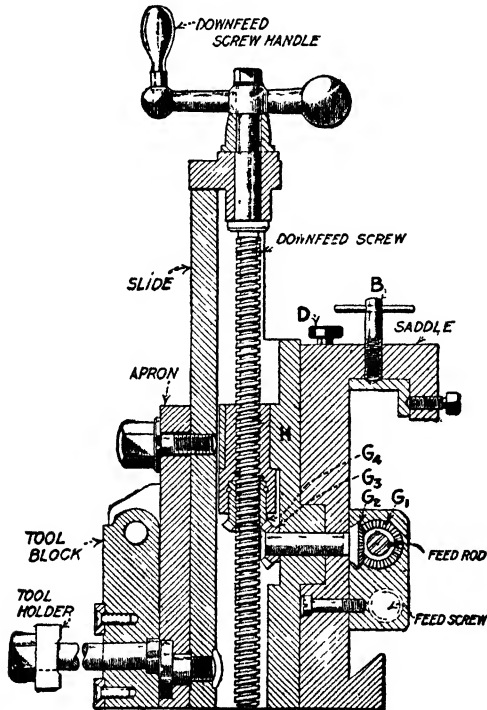


Fig. 3-4. Vertical section of planer head.

**Tool Head** (Fig. 3-4). In construction and operation, the planer head is very similar to the shaper head. As in the shaper head, the vertical adjustment of the tool is made by turning the downfeed screw handle. The *planer head*, however, is always provided with power downfeed, motion being transmitted from the feed rod through a toothed clutch feathered on the rod, thence through two pairs of bevel gears,  $G_1$  and  $G_2$ ,  $G_3$  and  $G_4$ , to the downfeed screw. When power downfeed is to be used, the gear  $G_1$  is engaged with  $G_2$  by turning a small knob or lever  $D$ .

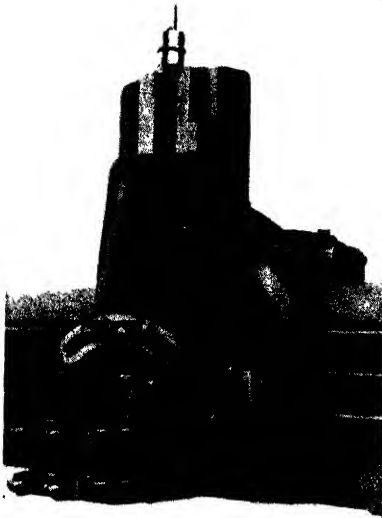


Fig. 3-5. A close-up of a tool head. (The G. A. Gray Company)

The tool-head slide is mounted on a swivel plate, or "harp," *H*, which is fastened to the saddle by two or more clamping bolts. When the bolts are loosened slightly, the head may be swiveled through an angle of 70 deg. either side of its vertical or normal position. Graduations in degrees indicate the angular setting. Similarly, as in the shaper head, the *apron* may be set over either side in order that the tool may clear the work when a vertical or angular cut is being taken.

A saddle-binder screw *B* is provided for holding the saddle rigidly in position when taking

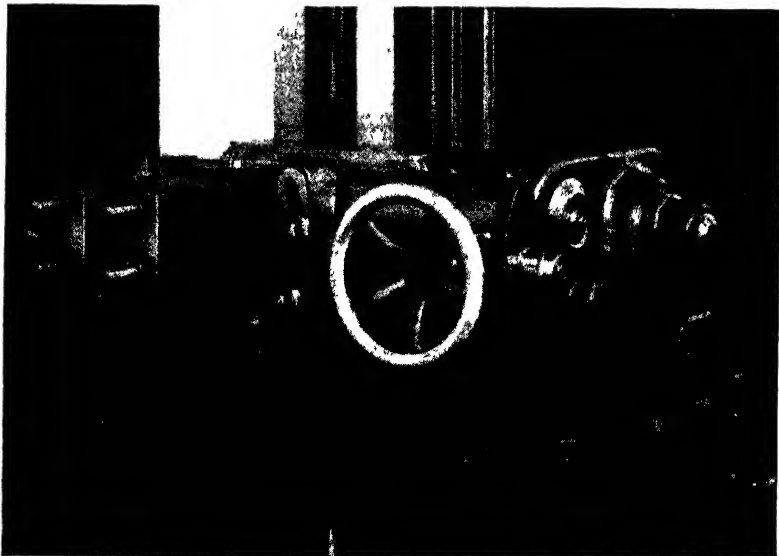


Fig. 3-6. A close-up of a side tool head. (The G. A. Gray Company)

a vertical or bevel cut, and a toolslide binder screw is provided for holding the toolslide when a horizontal cut is taken. Do not forget to loosen these screws when it is desired to move either part. *Remember always that every moving part of a machine should move freely.* Figure 3-5 shows a tool head mounted on the crossrail, for cross-feed. Figure 3-6 shows a side tool head mounted for vertical feed.

**Quiet-running Qualities of Planer.** Great care is taken in the design and construction of planers to ensure smooth running and long life. The gears are of ample size and are cut from the solid with special cutters made for the particular number of teeth in each gear. The shafts and bearings are proportionally large; in fact, the whole machine is especially rugged. If proper care is taken to keep the ways and other flat bearing surfaces cleaned, all the bearings, round and flat, properly oiled, and the gears well greased, a planer will keep quiet and do its work indefinitely. The boy who has learned to use a rag and an oil can *intelligently* on the machine he is running has gone a long way toward understanding the construction of the machine.

**Planer Feeds and Speeds.** It is impossible to recommend definite speeds and feeds for all types of jobs. The size of the work often limits the speed and the feed which can be used. In other cases, the clamping of the work on the table or in a fixture may be the limiting

**Cutting Speeds, in Feet per Minute**

Depth of cut Feed	For high-speed steel tools				For cast alloy tools				For carbide- tipped tools			
	$\frac{1}{8}$	$\frac{1}{4}$	$\frac{1}{2}$	1	$\frac{1}{8}$	$\frac{1}{4}$	$\frac{1}{2}$	1	$\frac{1}{16}$	$\frac{3}{16}$	$\frac{3}{8}$	$\frac{3}{4}$
	$\frac{1}{32}$	$\frac{1}{16}$	$\frac{3}{32}$	$\frac{1}{8}$	$\frac{1}{32}$	$\frac{1}{16}$	$\frac{3}{32}$	$\frac{1}{8}$	$\frac{1}{32}$	$\frac{1}{32}$	$\frac{1}{16}$	$\frac{1}{16}$
Cast iron, soft	95	75	60	50	160	135	110	95	255	205	165	140
Cast iron, medium	70	55	45	35	125	105	90	75	205	165	135	110
Cast iron, hard	45	35	25	..	95	80	65	..	140	110	90	..
Steel, free cutting	90	70	55	40	140	105	85	65	315	245	190	140
Steel, average	70	55	40	30	105	80	60	45	270	205	160	120
Steel, low machin- ability	40	30	25	..	65	50	40	..	195	145	115	..
Bronze	150	150	125	..	*	*	*	*	*	*	*	*
Aluminum	200	200	150	..	*	*	*	*	*	*	*	*

\* Maximum table speed.



factor. The ability of the work to withstand the pressure of the cut often limits the amount of feed which can be used. The power of the drive motor may be the limiting factor when heavy cuts are taken with several tools at one time. The speeds and feeds listed in the following table represent approximate values. In actual practice, the best speed and feed for the job must be determined by trial.

#### *Safety Precautions for the Planer*

1. *Do not ride the platen.*
2. Keep sleeves rolled up past the elbows.
3. Do not wear a tie. If you *must* wear one, wear a *bow* tie.
4. Never stand *in front* of the planer when in operation. The platen may strike you and cause injuries.
5. Be *sure* that the work is properly clamped. Test before taking the first cut.
6. Be sure that the stop dogs are firmly installed.
7. *No "foolin' around."*
8. Before starting the machine, make sure that the work clears the crossrail and tool heads.

#### QUESTIONS ON PLANER CONSTRUCTION

1. What is the value of the planer in the machine shop?
2. If a machine shop had a planer and a shaper, tell when each would be used.
3. What is the platen? What is its function?
4. What is the purpose of having a rapid return of the platen?
5. Why are the holes in the platen reamed?
6. What type of motion has the platen?
7. A planer having a sidehead as well as a rail head has what advantages over a planer without a sidehead?
8. What should a planer operator know about the machine if he is to become an expert planer operator?
9. Why is the planer a good machine tool for finishing long, thin stock?
10. How are planers classified? Give an example.
11. What is meant by an openside planer? double-housing planer?
12. What is carried on the crossrail?
13. What is the purpose of the tool lifter?
14. What safety precautions should be observed by the planer operator?

---

## CHAPTER 4

---

### Planer Work

Planer work is especially important for several reasons: (1) It is, for the most part, the finishing of accurate surfaces on expensive pieces. (2) It calls for more than ordinary intelligence, ingenuity, confidence, and carefulness. (3) It is interesting because it demands mental effort and manual skill to an unusual degree. (4) It pays better than average.

Planer work as a whole involves a considerable knowledge of general machine-shop skills, such as grinding and setting the cutting tools, judging speeds and feeds, measuring, etc. It involves the same sort of information as that used in shaper work; for example, how to get flat, square, angular, or irregular surfaces. Other similarities might be mentioned but, in addition to all of these, planer work has its own special requirements of laying out, leveling, and clamping work.

Like every other machine operation, planer work is easy enough if one knows how. At first, however, the expert planer hand had, somehow, to learn the fundamentals. In the beginning he found it fairly difficult to level the work and apply the clamps and stops mechanically right. He was probably a trifle nervous about the depth of cut and the feed, and, no doubt, fearful of a shoulder. But, because he studied and reasoned and worked intelligently on one job after another, he gained knowledge and skill.

#### METHODS OF HOLDING WORK

A great variety of shapes and sizes of work may be machined in the planer, and of course, this means that a variety of holding and clamping devices are necessary planer equipment.

Planer "furniture," in common with the work-holding appliances of any other machine tool, may be roughly divided into two classes—general-utility tools and special tools. In planer work, as in other machine work, the need and value of the special tools and fixtures is determined by the quantity of the work. That is, in case a great many duplicate pieces are to be planed, it is economical to make a fixture in which the work may be quickly set up, correctly aligned, suitably supported, and properly clamped. The fixture may be designed to hold a single piece or a dozen or more, depending on the size of the work.

On the other hand, for a single piece or a small quantity, the work could very well be held by means of general-utility furniture—

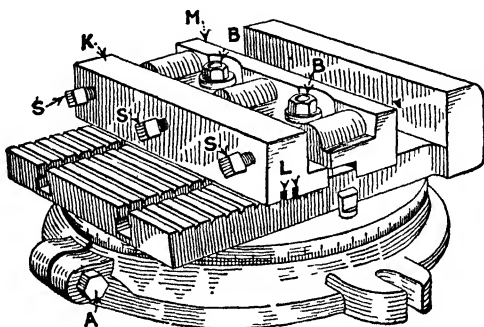


Fig. 4-1. The planer vise.

clamps, stops, angle irons, strips—whichever of them seems best suited. Certainly one who can intelligently use the regular holding tools will have no trouble using a fixture.

**Planer Vise.** The planer vise, sometimes called the planer chuck, is very useful for holding many jobs that are too large or of a shape such as to be impracticable for machining in the shaper. Planer vises are made with plain or swivel bases. Figure 4-1 illustrates a swivel vise. By loosening the binding screw *A* (in some vises, one, and in others, two) the body of the vise may be set in any desired position, the angle of the setting being indicated by graduations in degrees. A taper pin, with a squared head for easy removal, is sometimes provided exactly to locate the vise when the jaws are either parallel or at right angles to the direction of the cut. One jaw of the vise is fixed, and *T* slots are provided in the body for clamping the

movable jaw *M* by means of the two bolts *B*. The upper face of the body has cross slots to receive the thrust strips *L*, held in the backing block *K*, which are provided to keep the backing block from slipping after it is located. To fasten the work in the vise, place it against the solid jaw, move the sliding jaw up to the work, and tighten the nuts *B* lightly; bring up the backing block with the thinner section partly under the movable jaw and the thrust strips in the slots; tighten the three setscrews *S* sufficiently tight to hold the work; tap the work with a lead hammer, to make sure it is seated properly, before applying the final clamping pressure. This is particularly important when several pieces are clamped at a time because the center pieces always tend to lift up. Now tighten the nuts *B*.

Vise-work operations in the planer and shaper are in principle exactly alike. The planer has the advantage of a longer cut. A piece much longer than the vise may be planed if a suitable support, a jack for example, is provided under each of the projecting ends.

**Planer Centers** (Fig. 4-2). These appliances are comparatively little used as a means of holding work. Most jobs that require indexing can be more advantageously done on a milling machine. There are, however, occasions in the building of special tools and machines when the planer centers offer the most expedient way, or perhaps the only way, of finishing a given flat surface or a given curved surface, or one or more slots in an exact relation to a part already turned or in relation to a hole in which a mandrel may be inserted.

A suitable dog is fastened on the work or the mandrel, and the tail is clamped in the slotted driver by a setscrew after the work has been adjusted between the centers. The work may be adjusted for position by turning the handle which operates the worm and the worm wheel, and it is held in this position by the index plunger. For some pieces it may be advisable to take further measures for securing or steadying the work by blocks and jacks.

If it is desired to plane a curved surface, the tool is set "on center," a distance equal to the radius desired above center, and the work is "fed" for each cut by moving the worm handle a part of a turn.

The tailstock center is inserted in a block, adjustable vertically, for the purpose of planing tapered work.

**Holding the Work on the Platen.** In ordinary planer practice relatively few pieces are held by any of the methods previously

mentioned; by far the greater proportion of the work must be fastened more or less directly on the planer platen.

To be able to "set up" the average planer job intelligently, the operator must know the tools used for holding and clamping and the principles of their application. For the best method of clamping he must often rely upon his ingenuity.



**Fig. 4-2.** Planer centers Roll being machined in a planer using planer centers for indexing purposes. (*The G. A. Gray Company*)

The success of any job that must be clamped to the table of any machine such as the shaper, drill press, boring mill, or milling machine; the faceplate of a lathe; or the platen of a planer, depends almost entirely on the manner in which it is clamped, that is, on the knowledge and resourcefulness of the operator. Efficient clamping looks simple enough, but it certainly calls for brains.

### CLAMPING ACCESSORIES

**Bolts.** The familiar squarehead bolt (Fig. 4-3) is largely used and for ordinary clamping purposes is satisfactory. To be placed in posi-

tion, it must be pushed along the T slot from one end. The T-head bolt offers the advantage of being quickly placed in position, as

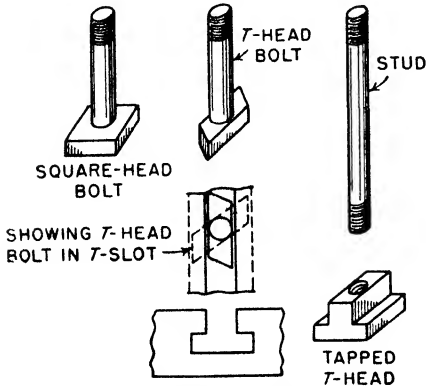


Fig. 4-3. Bolts.

shown. Simply drop the head lengthwise into the slot and turn it to the right. This is especially convenient for clamping on the inside of castings which would otherwise have to be lifted over the bolt. Many prefer the tapped T head, which is stronger and, in the end, probably more economical. If it is required to clamp inside a casting, the stud may be removed and the head pushed along the slot under

the casting to the desired position. Studs of various lengths may be used as needed, only a comparatively small number of tapped heads being required.

**Clamps.** For a description of some of the more common clamps used in planer work, study pages 45 to 47, Chapter 2, Shaper Work.

**Clamping Blocks.** The block under the outer end of the clamp may consist of a piece of handy scrap metal of the required dimensions or, if of considerable height, suitable pieces of hardwood may be employed. Have the wood of sufficient cross section to give the needed stiffness, and arrange the pieces under

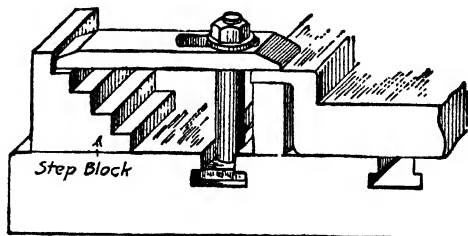


Fig. 4-4. Use of a step block.

the clamp so that the pressure will be exerted *lengthwise of the grain*, to avoid crushing. Figure 4-4 shows a step block which is very useful. Both bases are finished and either may be used.

**Shims.** A shim is a piece placed between the table and the work, or, for that matter, between any two pieces or parts to allow adjust-

ment or to give support. A shim may be rectangular or tapered slightly, and it may be of metal, wood, or paper. Usually, however, a shim is regarded as a thin piece of metal, while the heavier pieces are called "packing blocks."

**Planer Jacks.** For leveling up work or for supporting projections under cutting pressure, a jack is an invaluable tool. Figure 4-5 illustrates a very convenient size. The jack *a* is about  $1\frac{1}{4}$  in. in diameter at the base and has a range from  $2\frac{1}{4}$  to  $3\frac{5}{8}$  in. Two extension bases

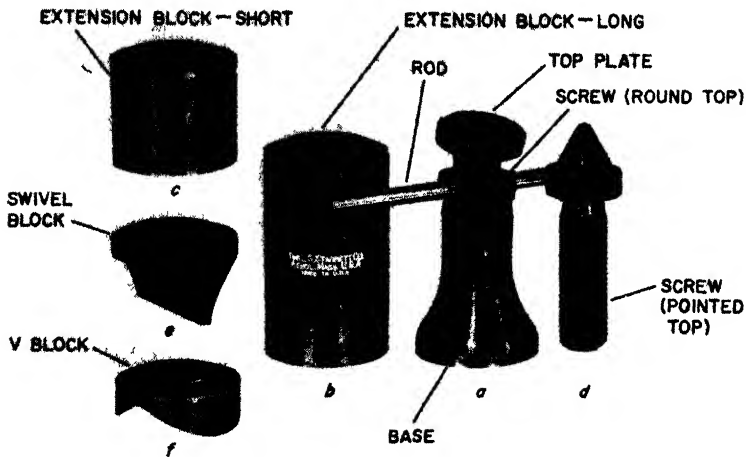


Fig. 4-5. Planer jack (*The L S Starrett Company*)

*b* and *c* are provided to extend the range to  $6\frac{1}{2}$  in. The swivel base *e* is supplied for use when such a shape is desirable and when the jack has to be turned for positioning. The pointed-top screw *d* is provided to be used in place of the screw with the swivel cap, in certain places where it may be needed, as in a corner, for example. The V block *f* is also supplied for positioning purposes.

**Braces.** Sometimes a job is of such proportions, fairly high and with a comparatively small seating surface, that braces are necessary to assist against the tendency to tip under the cutting pressure. Wooden braces, arranged from the work to stops in the table, are usually satisfactory.

If, however, a more substantial brace or perhaps an adjustable brace is desired, a piece of pipe of the length required may be provided between the jack *a* and the base *e* (Fig. 4-5), giving an excellent adjustable brace. A piece of pipe, with a washer, nut, and bolt or screw arranged in one end for the purpose of adjustment, makes a very satisfactory brace.

**Planer Poppets, Stops, Toe Dogs.** *Planer Poppets.* These may be made in either style, *a* or *b* (Fig. 4-6). The hole is drilled and tapped about 10 deg. out of parallel with the platen to give the screw

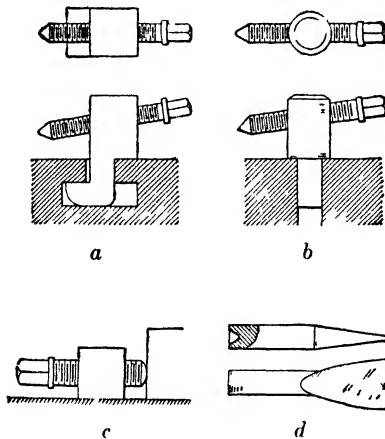


Fig. 4-6. *a* and *b*, planer poppets, *c*, stop for work, *d*, toe dog.

a certain downward thrust when in use. Style *b* may be made of round or square stock, as desired.

*Stops.* A stop is a metal block designed to prevent the work from moving endwise or sidewise under the thrust of the cut. It is usually provided with a setscrew to permit a certain amount of adjustment. Often one or two stops will act as well as half a dozen extra clamps on the work. A poppet made as shown at *c*, with the screw set low and parallel with the platen, is very satisfactory as a stop. Or a clamp securely tightened to the platen may be used.

*Toe Dogs* (*d*, Fig. 4-6). Used in connection with the poppets, toe dogs offer an excellent holding device, especially for thin work. To protect the planer table a piece of thin stock—for example, a



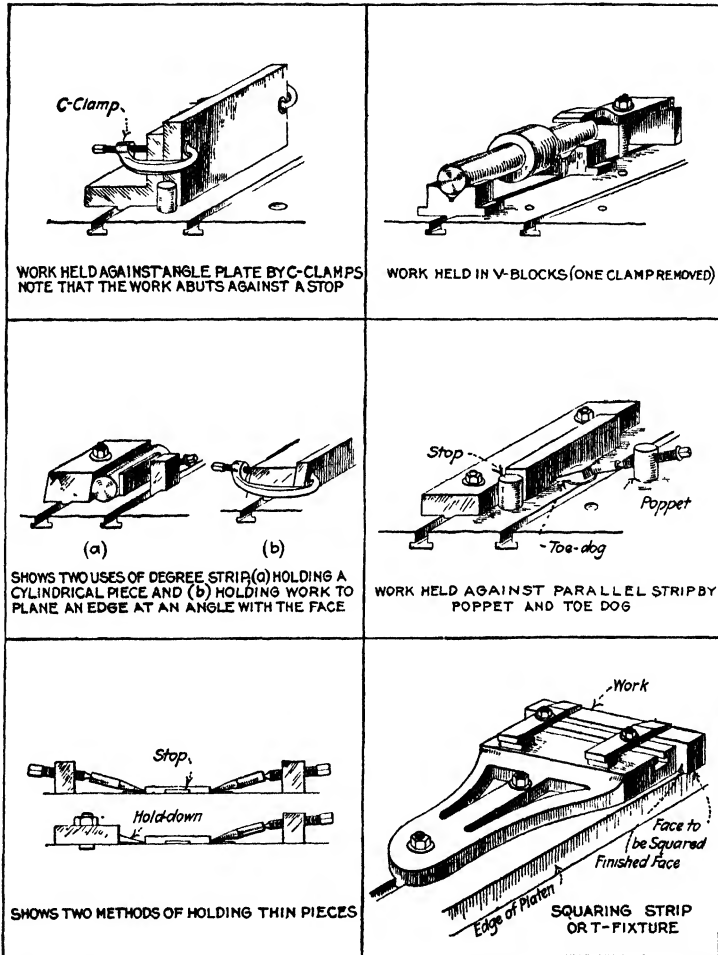


Fig. 4-7. Typical planer setups. In any planer setup, the idea is to have the work neatly and securely clamped, a stop used if possible, and particular care taken not to spring any part of the work. Avoid using bolts that are too short or much too long. The surfaces of all strips, parallels, and fixtures must be clean and free from burrs. Take real care to have the setup *mechanically* right.

washer—should be placed under the toe (see Fig. 4-7; also Fig. 4-9). A positive stop should nearly always be used when the work is held by toe dogs, and great care should be taken not to buckle the work by unduly tightening the poppet screws.

Suitable lengths of "pins," made, for example, of tempered steel about  $\frac{1}{2}$  in. in diameter, are sometimes used instead of toe dogs. They are pointed similar to a center punch on one end, to hold the work, and the other end is rounded to fit against a *cupped*-end poppet screw. If they are arranged to point slightly toward the stop, they will tend to hold the work snugly against the stop as well as down on the platen.

**Planer Strips, V Blocks, Angle Plates** (Fig. 4-7). These are pieces of metal, usually cast iron, with a uniform cross section of the desired shape and size and of any convenient length. The base surface of each is tongued or provided with keys that fit the slots in the platen, and bolt holes or flanges are provided for the purpose of clamping. Two or more may be used for the longer work or when several short pieces are to be planed at one setting.

### PRINCIPLES OF CLAMPING

What knowledge is necessary in order to produce planer work of satisfactory quality and quantity? What must one know to avoid inaccurate or spoiled work, to minimize the chances of accident to work or machine? In other words, what are the factors in planer work that make for skill? The answer may be stated very briefly: Handling the machine intelligently, knowing which tools to use, and taking the cuts to advantage are necessary and important factors, but it is safe to say that 90 per cent of planer skill is in *knowing how to hold the work*.

**Internal Stresses.** A very large proportion of planer work consists of machining castings, mostly iron castings, direct from the foundry.

When a casting is poured, the molten metal coming in contact with the surface of the mold chills quickly and forms a skin, or "scale," which is much harder and more brittle than the inside. This uneven cooling and the fact that the thin sections of the casting cool more quickly than the heavier parts cause interior stresses.

These stresses are held more or less in subjection by the scale, and when the scale is removed the casting gives or warps.

This is the reason why the roughing cuts should all be taken before any face is finished. This procedure is not always necessary but should be followed if practicable, and must be followed if a certain degree of accuracy is desired. If extreme accuracy is required, the casting should be allowed to "season" between the roughing and finishing cuts.

**External Stresses.** Practically all metals used in machine-shop practice—iron, steel, brass, aluminum, etc.—spring under pressure. If a piece is clamped in such a way that it is sprung or buckled while the cut is taken, when the pressure is released and the piece resumes its natural shape, the machined surface will be inaccurate.

For this reason it is essential, if the work does not seat perfectly, that it be shimmed or blocked, *particularly under the clamps*, to avoid springing. Usually, the sound of a light hammer blow, *before the clamps are applied*, will indicate whether or not the piece is properly seated. A piece may be jacked or braced, to avoid the tendency to spring under the cutting action. Be careful, especially if screw action is used, not to set up the brace or jack too tight.

**Placing the Clamps and Stops.** A clamp should be properly placed and the packing block under the clamp must be the correct height or the work may become loosened, with probable damage to both work and machine.

A very important point to be observed in the clamping of work is the position of the clamping bolt. It should be placed as near the work as conditions will permit.

The clamp should have a firm seat on both the work and the clamping block. Packing under the outer end of the clamp should be at least high enough to bring the clamp parallel with the surface on which the work rests. It must never be lower, or the clamp will have contact only on the edge of the work. It may be a trifle higher to ensure against an edge contact, but if it is either too high or too low, the bolthead contact in the "T" slot and the nut-and-washer contact on the clamp are faulty, and the clamping force correspondingly weak.

The clamp must not be placed over a part that will give or spring under pressure until suitable packing is placed under that part.

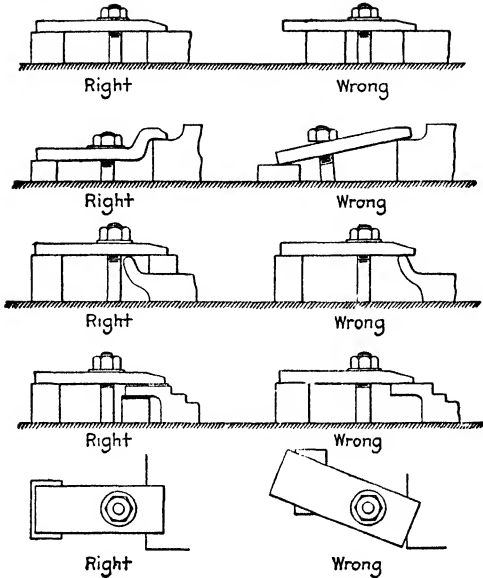


Fig. 4-8. Right and wrong applications of clamps.

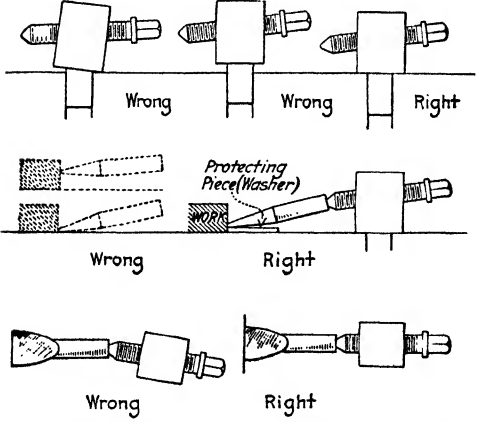


Fig. 4-9. Right and wrong uses of poppets and toe dogs.

In Figs. 4-8 and 4-9 are illustrated right and wrong methods of using clamps, poppets, and toe dogs.

The work should be held in the machine in such a way that it will not move under the cutting pressure. In planer work, the thrust of the tool is mostly in a forward direction and comparatively little in a sidewise direction. It is nearly always possible and advisable to use positive stops. Poppets may often be used, but if these are too high, a clamp may be bolted to the table; if they are not high enough, possibly an angle plate bolted to the table will do.

The first-class planer hand uses clamps and stops *when, where, and as* he should. As previously stated, this calls for brains. Size up the work to be planed, use *reasoning* when determining how best to hold it, place the stops, clamps, strips, poppets, toe dogs, whatever is necessary to hold the work, with careful attention to having them placed and adjusted exactly right. If one does this, the chances are that it is a good setup, and a good setup is often more than half the job.

### CLAMPING HINTS

1. Do not depend on the accuracy of vise jaws, parallels, angle irons, etc., without testing them.
2. Do not put a clamp on a finished surface without a protecting piece.
3. It is very easy to score the table by sliding a rough casting across its surface. Put down protecting pieces of cardboard or similar material. Also, do not fail to protect vise jaws, angle irons, parallels, etc., when clamping castings and forgings.
4. Many pieces are spoiled through carelessness in cleaning the parts against which the work seats or is clamped. When a piece is clamped in a vise, or against an angle iron or similar tool, care must be taken to clean away all chips and dirt.
5. After a piece is clamped in a vise, tap lightly with a Babbitt hammer to seat it. Do not tighten the vise again after seating the work, as this is likely to lift the work from its seat.
6. When work is held on a table against an angle iron or similar piece, place tissue paper under each end of the work to determine if it is properly seated. Tap it lightly if necessary.

7. Use a stop against the work wherever convenient, and avoid unnecessary clamping.
8. It is very easy to buckle a thin piece, and great care must be taken when clamping such a piece in a vise, or when using hold-downs or toe dogs.
9. Form the habit of sighting over the top of the work under the crossrail, and along the sides next to the housings *after* clamping, to make sure everything is clear.
10. Use the proper-size wrench to avoid rounding the corners of the nuts.
11. The selection of the wrench, the way it is held and *controlled*, and the judgment used in the amount of force exerted, are indications of a mechanic's skill.
12. The thread of the bolt or nut should be oiled occasionally to save time and trouble.
13. Never use a nut without a washer.
14. Avoid, if possible, using bolts that are excessively long, and do not in any circumstances use a bolt too short, with only three or four threads catching in the nut.
15. Particular care should be taken to return clamps, bolts, and all other clamping accessories to the place where they belong. This is only fair to all concerned.
16. To plane several pieces (a "string") at one time saves a considerable amount of time in adjusting and measuring, and very frequently in the cutting operation. If many duplicate pieces are to be planed, a "string fixture" has many advantages in respect to saving time and labor.

### PLANER-WORK PROCEDURES

**Leveling.** As previously stated, most work comes to the planer in the shape of rough castings. Leveling is the process of setting up the casting in such a manner (1) that it will machine to size and to the best advantage, and (2) that it is supported at the proper points by blocks, shims, or braces so that it will not buckle or spring under the clamping pressure.

In many cases, if care is not taken in leveling in the setup, the casting will not clean to dimensions required. Sometimes even a sim-

ple casting—a plate, for example—with apparently plenty of metal for machining, will be so badly warped that extra care must be taken when setting up for planing the first or working surface. It must be leveled with a surface gage (Fig. 4-10) in such a way as to average the corners for height, with due consideration for later planing of the

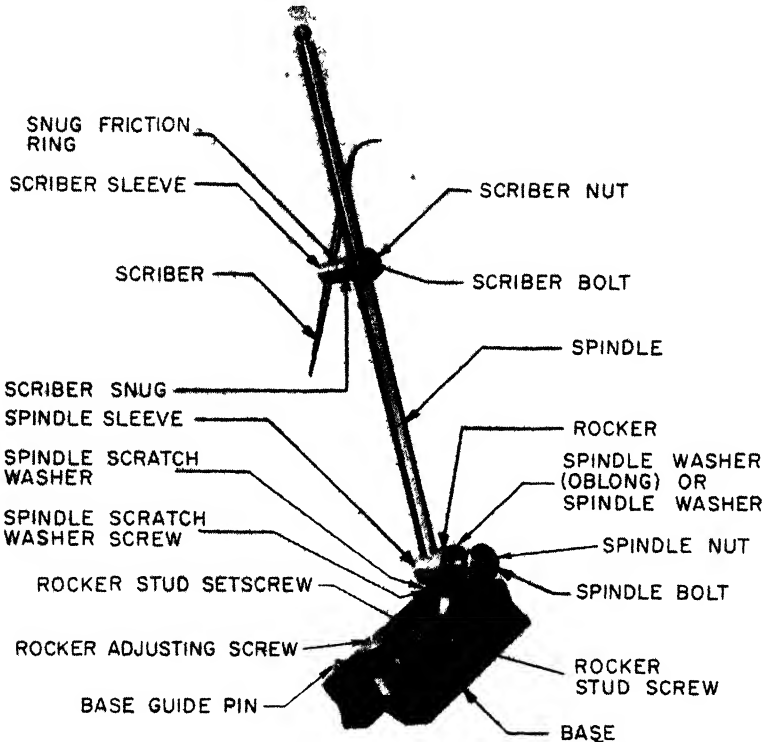


Fig. 4-10. Surface gage. This is an invaluable tool in planer work for scribing lines and for leveling either a surface or a line (*The L. S. Starrett Company*)

other side. It will possibly be necessary to shim under two corners, maybe three, and possibly all four corners. In addition, shims will no doubt have to be placed under certain points where the clamps are to be applied, no matter what kind of clamping device is used. This is because the tremendous screw pressure of the bolt and nut will

spring even a heavy casting unless it is solidly supported under the clamp.

**Laying Out.** The leveling of the usual casting means only proper blocking, shimming, and clamping, but averaging the surfaces of an intricate casting, or one having surfaces likely for any reason to be scant, calls for a preliminary layout. Usually this work is done before the casting comes to the planer, but quite often the planer hand must do it.

Every casting, but more particularly the irregular-shaped piece, has a base and possibly a side "working surface" that must be established before cuts are taken. The planer hand must know *how much stock* to take off these surfaces and *where* it must be removed. For example, it may be that  $\frac{3}{16}$  in. must be taken off one part of the base and only the scale from another part, in order that the casting will "clean up"; that is, every other surface that must be planed will have stock enough to finish. If other surfaces must be planed to finish a certain distance from a side or an edge, then the working side or edge must be established and the dimensions checked to make sure all surfaces will clean. In other words, if the machinist sets the casting without realizing that a certain surface, being low or "scant," should be "favored" and proceeds to take an even cut from the working surface, then the low part, in a later setup, will not clean, and the job is spoiled.

To check the dimensions from the base or edge, the work is tentatively leveled on a plate or table, often on the planer platen, and a layout is usually made. This layout is, in a sense, the measuring of a casting; lines are drawn on the chalked surfaces to verify on the casting the dimensions given on the drawing. The layout does not usually have to be especially accurate; the lines are merely check lines.

The tools used are various blocks and shims to use in leveling, parallels of the sizes required, one or more surface gages, a combination square, scales, a scribe, possibly a bevel protractor. For scribing distances, dividers and trammel points are often used. To whiten the surface, chalk may be rubbed on, or a mixture of chalk and water (whiting) may be applied with a brush.

Set up the casting to have it appear about right, shimming where necessary; that is, make a tentative leveling, and with a surface gage



or scale check any surface that seems to be low. If releveling is necessary, shim the work to bring the low surfaces high enough to clean. Sometimes, when the lines are being scribed, it will be found that a surface is undersize, which means that the casting will have to be leveled again and a new layout made. This is much better than finding the low surface after several cuts have been made and the work possibly spoiled.

Base lines or, if more convenient, lines that are parallel to the base should be scribed. These are used in setting up for planing the base.

After the layout is complete, the work is usually leveled to the base-surface layout, clamped, and the base planed. When the remaining surfaces are planed, the machinist does not, ordinarily, plane to the lines; the surfaces are *measured* or *gaged* from the base, or from another finished surface, as the case may be.

**Measuring and Gaging.** The test of a plane surface is, first its flatness, second its relation to another surface—its squareness or its other angularity to this surface, or its distance from another surface. The best method of testing for flatness is by placing a suitable straightedge on the work, or by turning the work over and placing the surface to be tested on a surface known to be flat. In the latter case, the platen of the planer is frequently used. When the surface is flat, there is no “rock” of the work on the platen or no “hollow sound” under a light blow given anywhere on the work.

If a straightedge is used, it should be tried in several positions on the surface with tissue-paper feelers<sup>1</sup> to determine the straightness and flatness of the surface. Feelers may often be used in a similar way between the corners of the work and the surface plate or planer platen.

Tissue-paper feelers are frequently used with a square to test whether a surface is at right angles with another surface, and they may be used with a bevel protractor to test the accuracy of an angular cut other than 90 deg.

For measuring or gaging the height of a surface, direct scale measurement may be good enough, or a surface gage set to a scale. For measuring the height of a shoulder, a size block (Fig. 2-53) or a

<sup>1</sup> If a straightedge is placed on a surface with narrow pieces of tissue paper between, say one at each end and one in the middle, and if any one of them pulls more easily than another, it indicates that the surface is not flat.

depth micrometer (Fig. 4-11) is useful. A combination square may be used to test the distance from one surface to another, either horizontally or vertically. When a considerable number of pieces are to be planed with angular cuts, shoulder cuts, etc., it is advisable to have tool-setting gages and work-testing gages as part of the equipment for that job.

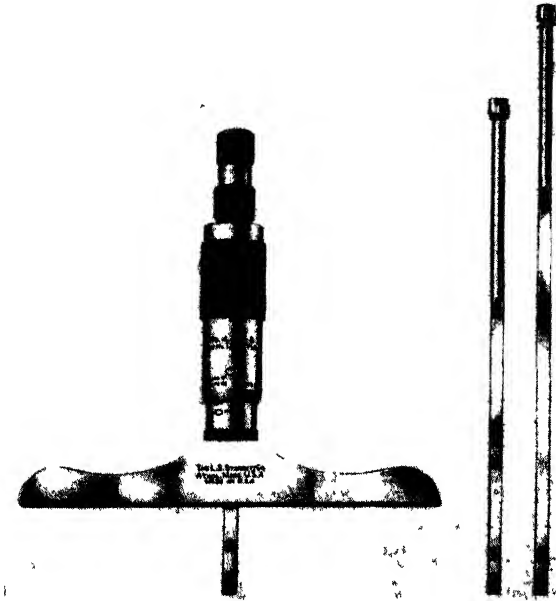


Fig. 4-11. A depth micrometer. (*The L. S. Starrett Company*)

**Planer Gage.** Another useful tool for planer operators is the planer gage (used on shapers as well). With this gage, time spent in adjusting the cutting tool is reduced to a minimum. This tool (Fig. 4-12) is provided with an adjustable slide, which can be moved along the base for various dimensions. It also has extension blocks (a 3-in. block is shown), which make it very versatile for a great many uses.

Planer gages are manufactured in various designs, but the principle of operation in most cases is exactly the same. The gages shown in Figs. 4-13 and 4-14 are different in some respects but, when used, all perform in almost the same way.

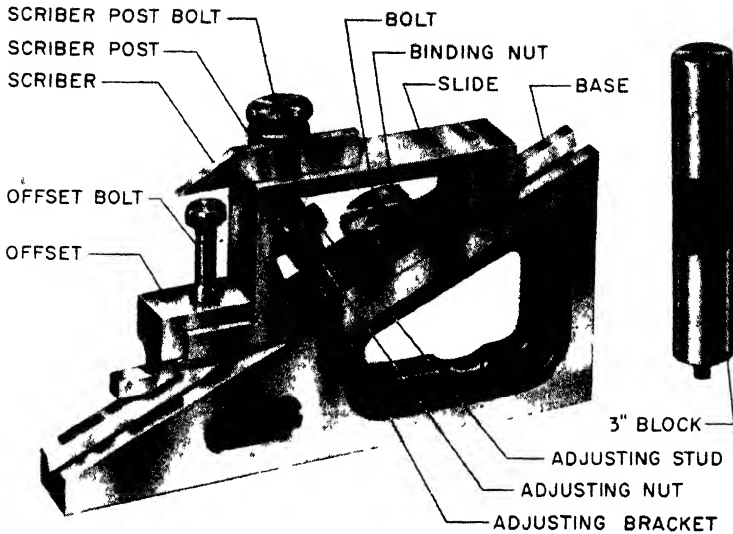


Fig. 4-12. Planer gage with parts identified. (The L. S. Starrett Company)



Fig. 4-13. Setting the planer tool. (The Brown & Sharpe Manufacturing Company)

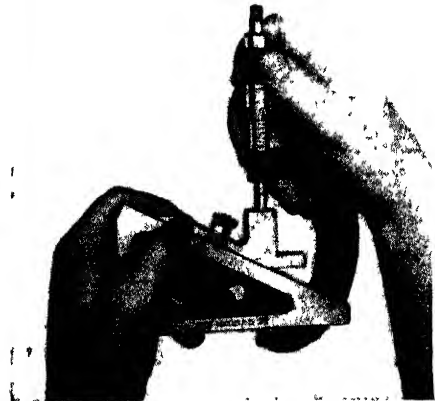


Fig. 4-14. Setting the height of the planer gage with a micrometer. (The Brown & Sharpe Manufacturing Company)

Figure 4-13 shows the planer gage being used in the setting of the planer tool. Figure 4-14 shows the height being set with the aid of a micrometer. Thus the gage has a wide range of sizes, which may be set by micrometer measurement to gage the width of slots, shoulder distances, or like dimensions, and to set the edge of the cutting tool, either a vertical or a horizontal distance from a base or a shoulder.

**Planer Cutting Tools.** The cutting tools generally used on planers are substantially like shaper tools for similar operations, the only difference being the size.

The following cutting tools are recommended by The G. A. Gray Company for use on their planers:

1. *Round-nosed Roughing Tool for Cast Iron* (Fig. 4-15a). Made of high-speed steel. General purpose, light roughing tool which can be used in feeding from right to left or from left to right. If surfaces *A* and *B* (Fig. 4-15b) should be at the same height, the tool is fed first over *A*, then without changing the setting it is fed from the left over surface *B* as indicated. Since the tool has no side rake, the depth of cut should not be more than  $\frac{1}{2}$  in.

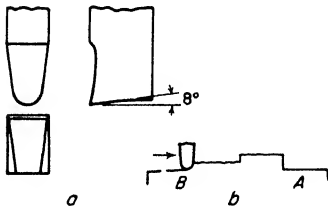


Fig. 4-15. Tool No. 1. (a) Round-nosed roughing tool for cast iron; (b) application of the tool. (The G. A. Gray Company)

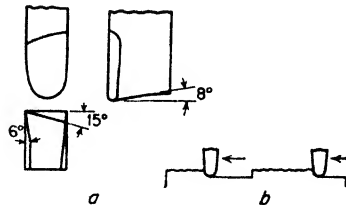


Fig. 4-16. Tool No. 2. (a) Right-hand round-nosed roughing tool; (b) application of the tool. (The G. A. Gray Company)

2. *Right-hand Round-nosed Roughing Tool* (Fig. 4-16a). Made of high-speed steel. The operator should have two of these tools for a planer with two rail heads. They are used for practically all roughing of cast iron. Feed from right to left; that is, away from the operator. Figure 4-16b shows the direction of feed.

3. *Left-hand Round-nosed Roughing Tool* (Fig. 4-17a). Made of high-speed steel. Use when it is necessary to feed from left to right, toward the operator. Also for feeding down with the right-hand side-

head (Fig. 4-17b). This tool is used for planing cast iron. For cast-steel or forgings, see tool 5.

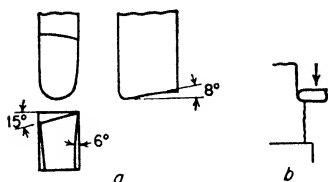


Fig. 4-17. Tool No. 3. (a) Left-hand round-nosed roughing tool; (b) Application of the tool. (The G. A. Gray Company)

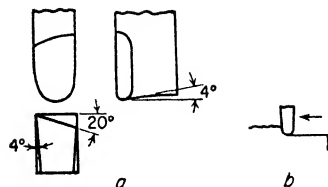


Fig. 4-18. Tool No. 4. (a) Right-hand round-nosed roughing tool for steel; (b) Application of the tool (The G. A. Gray Company)

4. *Right-hand Round-nosed Roughing Tool for Steel* (Fig. 4-18a). Made of high-speed steel. This tool is similar to tool 2 but is intended for roughing cuts in steel. The angles of this tool are not suitable for cast iron and, if used for that purpose, will pull in and cause chatter. This tool is for use in planing from right to left; that is, away from the operator (Fig. 4-18b).

5. *Left-hand Round-nosed Roughing Tool for Steel* (Fig. 4-19a). Made of high-speed steel. A companion tool to 4, used for roughing cuts in steel when feeding the head from left to right; that is, toward the operator, or when feeding down with the right-hand sidehead (Fig. 4-19b). If a considerable amount of stock is to be removed with tool 4 or tool 5, use a deep cut, heavy feed, and slow speed.

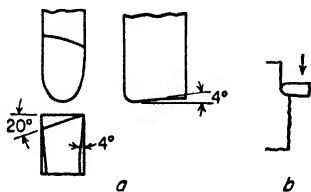


Fig. 4-19. Tool No. 5. (a) Left-hand round-nosed roughing tool for steel; (b) Application of the tool. (The G. A. Gray Company)

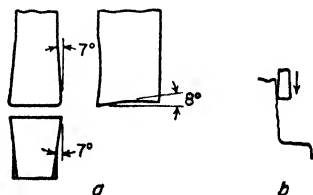


Fig. 4-20. Tool No. 6. (a) Square-nosed roughing tool for cast iron; (b) Application of the tool. (The G. A. Gray Company)

6. *Square-nosed Roughing Tool for Cast Iron* (Fig. 4-20a). Made of high-speed steel. For roughing cuts on flat surfaces where a sharp

corner is to be secured (Fig. 4-20b). This tool can also be used for straightening or heavy-finishing cuts when fine finish is not required (depth of cut, 0.004 to 0.005 in.). For lighter cuts and finer finishes, see tool 8. This tool can also be made by brazing a piece of high-speed steel on a machine steel shank.

7. *Square-nosed Finishing Tool for Cast Iron* (Fig. 4-21a). Made of high-speed steel. This is a general-purpose tool for straightening and finishing cuts (Fig. 4-21b). It is a good idea to have several on hand, of different widths, from  $\frac{3}{8}$  to 1 in. Be sure to have the cutting edge of the tool exactly parallel to the surface of the job, or the corner of the tool will dig in. The feed should be coarse, almost the width of the tool.

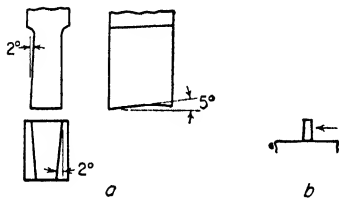


Fig. 4-21. Tool No. 7. (a) Square-nosed finishing tool for cast iron; (b) Application of the tool. (The G. A. Gray Company)

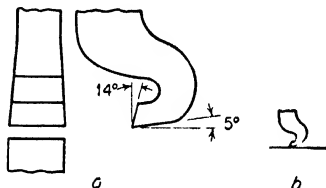
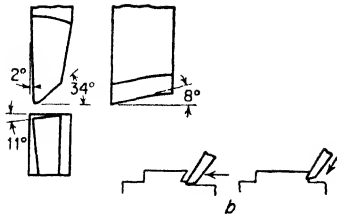


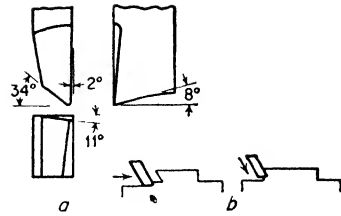
Fig. 4-22. Tool No. 8. (a) Gooseneck finishing tool for cast iron and steel; (b) Application of the tool. (The G. A. Gray Company)

8. *Gooseneck Finishing Tool for Cast Iron and Steel* (Fig. 4-22a). Made of high-carbon steel. For finishing flat surfaces in any metal, this tool, in combination with a very shallow cut and a coarse feed, is most satisfactory. After grinding, the cutting edge of the tool should be finished with an oilstone by hand to remove burrs and leave a keen, straight edge. Be sure that the cutting edge is exactly parallel to the surface of the job, or the corners of the tool will dig in (Fig. 4-22b).

9. *Right-hand Dovetail End-cutting Roughing Tool for Cast Iron* (Fig. 4-23a). Made of high-speed steel. This tool has the cutting edge at the end. The corner is rounded off so as to avoid breakdown in taking the roughing cut. It is to be followed by tool 11, which will leave a clean, sharp angle in the corner. This tool is to be fed downward or from right to left (Fig. 4-23b).



**Fig. 4-23.** Tool No. 9. (a) Right-hand dovetail end-cutting roughing tool for cast iron; (b) Application of the tool. (The G. A. Gray Company)

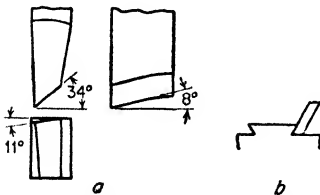


**Fig. 4-24.** Tool No. 10. (a) Left-hand dovetail end-cutting roughing tool for cast iron; (b) Application of the tool. (The G. A. Gray Company)

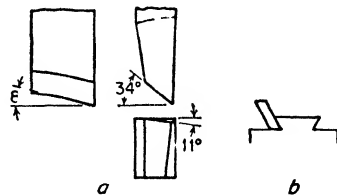
10. *Left-hand Dovetail End-cutting Roughing Tool for Cast Iron* (Fig. 4-24a). A companion to tool 9, this is to be used when feeding from left to right and downward (Fig. 4-24b). It may be followed by 12, to cut out a sharp angle. Made of high-speed steel.

11. *Right-hand Dovetail End-cutting Roughing Tool for Cast Iron* (Fig. 4-25a). Similar to tool 9 and intended to clean out corners after most of the metal has been removed by tool 9. This tool is not so well suited for general dovetail roughing as is tool 9, because the sharp corners break down. Feed downward or from right to left (Fig. 4-25b). Made of high-speed steel.

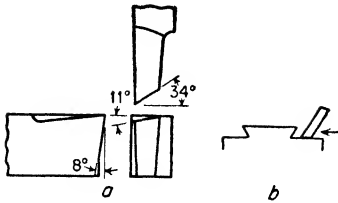
12. *Left-hand Dovetail End-cutting Roughing Tool for Cast Iron* (Fig. 4-26a). A companion for tool 11, used in feeding in the opposite direction; that is, from left to right (Fig. 4-26b). Can be fed downward. Made of high-speed steel.



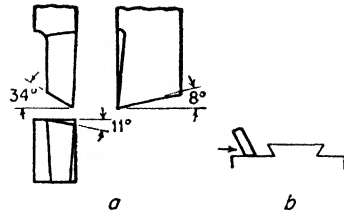
**Fig. 4-25.** Tool No. 11. (a) Right-hand dovetail end-cutting roughing tool for cast iron; (b) Application of the tool. (The G. A. Gray Company)



**Fig. 4-26.** Tool No. 12. (a) Left-hand dovetail end-cutting roughing tool for cast iron; (b) Application of the tool. (The G. A. Gray Company)



**Fig. 4-27.** Tool No. 13. (a) Right-hand dovetail end-cutting finishing tool for cast iron; (b) Application of the tool. (The G. A. Gray Company)



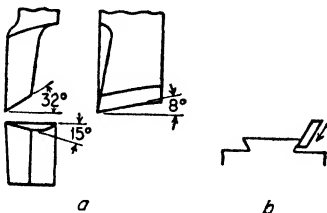
**Fig. 4-28.** Tool No. 14. (a) Left-hand dovetail end-cutting finishing tool for cast iron; (b) Application of the tool. (The G. A. Gray Company)

13. *Right-hand Dovetail End-cutting Finishing Tool for Cast Iron* (Fig. 4-27a). Made of high-carbon steel. For finishing flat surfaces with cutting edge at end of tool. Used after roughing cuts with tools 9 and 11. Feed from right to left (Fig. 4-27b).

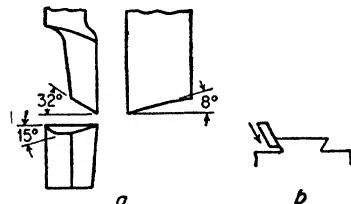
14. *Left-hand Dovetail End-cutting Finishing Tool for Cast Iron* (Fig. 4-28a). Made of high-carbon steel. Companion to tool 13. Use after tools 10 and 12. Feed from left to right (Fig. 4-28b).

15. *Right-hand Dovetail Side-cutting Finishing Tool for Cast Iron* (Fig. 4-29a). Made of high-carbon steel. Used for finishing angular surface of dovetail, as shown in Fig. 4-29b. Feed downward with coarse feed, taking a very light cut.

16. *Left-hand Dovetail Side-cutting Finishing Tool for Cast Iron* (Fig. 4-30a). Made of high-carbon steel. Companion for tool 15. Feed downward with a coarse feed (Fig. 4-30b).



**Fig. 4-29.** Tool No. 15. (a) Right-hand dovetail side-cutting finishing tool for cast iron; (b) Application of the tool. (The G. A. Gray Company)



**Fig. 4-30.** Tool No. 16. (a) Left-hand dovetail side-cutting finishing tool for cast iron; (b) Application of the tool. (The G. A. Gray Company)



Many machine shops use removable tool bits such as are shown in Fig. 4-31. The bits may be made of high-speed steel, or they may be tipped with cast alloy or sintered carbide. Various styles and shapes of tool bits can be used in the same toolholder. The tool bit can be removed from the holder while the holder is left in place in the tool apron. Figure 4-32 shows the type of toolholder ordinarily used with removable tool bits.

Some planers are probably equipped with three or four heads. To get the most out of the machine, as many tools must be used simultaneously as the job will permit.

Often the work must be arranged on the table in two rows, side by side, in order that all the heads may be used simultaneously.

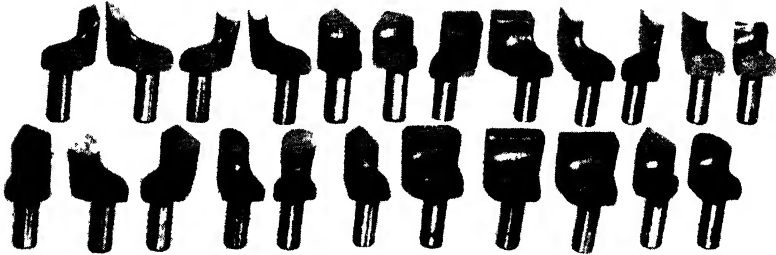


Fig. 4-31. Removable tool bits for planer use (*The O K. Tool Company*)

*Gang Tools.* As shown in Fig. 4-33, a gang tool, consisting of three or four tools set in a holder so that each tool takes its proportional share of the total feed, is sometimes used. This tool is especially adapted for surfacing large castings, and on this class of work, it will effect a large saving over the time required to do the same job with a single-point tool. The head is solidly secured to the shank, upon which it swivels, to a limited degree, by means of a deep and closely fitted tongue and socket; and, when set, its position is fixed by two steel collar screws, while two stop screws render slipping of the head impossible. The head is graduated, thus enabling the tool to be quickly and accurately set to any desired feed. It is a tool used, as a rule, in mass production, where time is very important.

Other recommendations made by The G. A. Gray Company pertaining to cutting tools are as follows:

1. For a fair finish, set roughing tool to final dimension. The finishing tool merely removes the high spots.

2. For accurate finish, leave 0.006 in. oversize when roughing. Take a straightening cut which leaves about 0.001 in. This is removed by the finishing cut.

3. Make tools from the following sizes of bar: 24- to 36-in. standard planers: 1- by  $1\frac{1}{2}$ -in. stock; 36- to 48-in. maximum service planers:  $1\frac{1}{8}$ - by  $1\frac{3}{4}$ -in. stock; 56- to 72-in. maximum service planers:  $1\frac{1}{4}$ - by 2-in. stock.

4. Planer tools with negative rake have the impact of the cut some distance behind the nose and are less likely to break the tip.



Fig. 4-32.

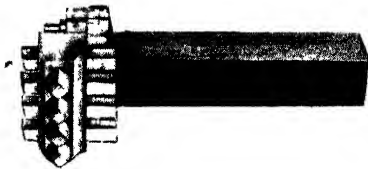


Fig. 4-33.

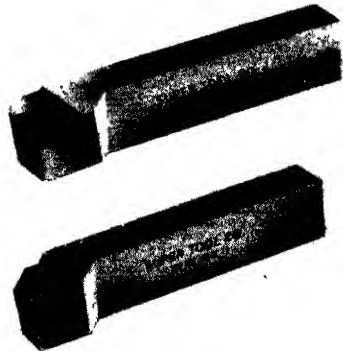


Fig. 4-34.

Fig. 4-32. Toolholder for removable tool bits. (*The O.K. Tool Company*)

Fig. 4-33. Gang toolholder with tools. (*The Armstrong Bros. Tool Company*)

Fig. 4-34. Carbide tools for planer use. (*The Super Tool Company*)

Although all the above-mentioned tools were made either of high-speed steel or high-carbon steel, many tools used on planers are carbide-tipped (Fig. 4-34). Because of its cost-cutting aspect, many of the progressive machine shops throughout the world have adopted the carbide planing technique as a means of substantially reducing production costs. Constant progress is being made in the design and development, and additional strides in the direction of higher cutting speeds, lower tool costs, and longer tool life may be expected.

Many tools have been developed and are commercially available that feature brazed-on tips. However, these are generally restricted to relatively fine cuts and light-duty work.

For those who are genuinely interested in these types of tools, it is recommended that the manufacturers of such tools be asked for any information needed. Two such manufacturers are the G. A. Gray Company and the Vascoloy-Ramet Corporation.

**Setting the Tool.** To accommodate different heights of work, the crossrail clamping device is loosened and the crossrail is adjusted

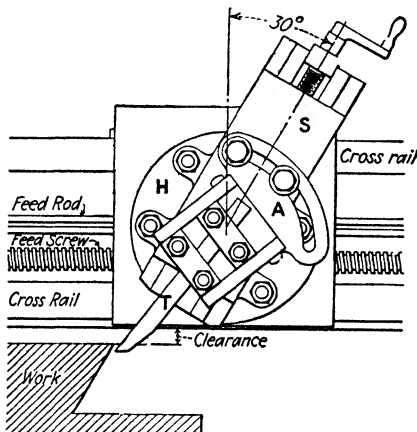


Fig. 4-35. Crossrail tool head set for 30-deg. angular cut, with the top of the apron *A* set over in a direction *away* from the surface being cut. Note that the slide *S* is well up at the start of the cut in order not to overhang too much at the bottom of the cut. Note also the *clearance* between the crossrail and the work. In this job, the tool *T* must project far enough to reach the bottom of the cut.

vertically. If there is doubt that the rail is parallel, test with an indicator.

If the crossrail is *set too low*, so that the work or the holding tools will not pass under (clear) during the cut, an accident is sure to happen. If the rail is *set too high*, it means that either the tool-head slide or the tool, or both, will project (overhang) too much, in order to have the tool reach the work. This will cause the tool to chatter on a light cut and to dig in on a heavier cut. Ordinarily an inch or two of clearance above the highest point of the work or the work holder is satisfactory. Note the clearance in Fig. 4-35.

When setting the planer tool, be certain that the clearance under the crossrail is all right—*enough and not too much*. Ordinarily there will be no overhang of the tool-head slide. For most horizontal cuts

the tool is held perpendicularly; if then, by any chance, it moves in the tool block, it will not cut deeper into the work. Catch the tool fairly short, for rigidity, and *always* clamp it tight.

When planing an angular cut, or a vertical cut using the crossrail head, it is best to have the slide well up at the start of the cut in order not to have it project too far as the tool reaches the bottom of the cut (see Fig. 4-35).

When it is necessary to have the tool overhang an unusual amount, a correspondingly light cut must be taken.

**Cutting Speed, Depth of Cut, and Feed.** In the planer, as in other machines, these must be considered. In the planer there is less need than in other machines for a variety of speeds, for the reason that the only variations to be considered are the kind of cutting tool used and the material being cut. A moment's thought will show that the speed of the planer need not be changed for different lengths of work, as in the shaper, or for different sizes of cutting tools, as in the drill press or the milling machine.

In many shops the planer is used altogether on the same class of materials and has but one speed forward, with a quicker return. However, four-speed countershafts and variators are not uncommon. They usually give cutting speeds of around 20 ft., 30 ft., 40 ft., and 50 ft. per min., and 100 ft. per min. return. (See Table 3, page 639.) The hydraulic planers have a continuous range from 0 ft. to 80 ft. per min. or more forward, and up to 150 ft. per min. return.

The planer is regarded as a rugged machine, capable of holding heavy pieces and taking heavy cuts. The very nature of the machine, carrying the heavy load, gives the impression of power. But while in theory the cutting speed, feed, and depth of cut are governed by the same conditions as in the lathe, shaper, or milling machine, it is probable that the planer averages much slower speeds than any other machine in the shop, for a number of reasons. For example: the nature of the machine, with its heavy reciprocating platen and load; the way most of the work must be held, such as irregular shapes held by clamps and braces; and the kind of cut, that is, machining very accurate surfaces on expensive castings. If the planer is equipped with speed changes, select the nearest speed suitable for the cutting tool and the material to be planed, with due consideration for the kind of setup and the nature of the operation.

The depth of the cut and the feed are also always governed by conditions. It is impossible to give a rule. The suggestions given on page 34 should prove helpful. Read these suggestions carefully; be sure to understand the importance of your judgment. Remember, it is thinking through each problem that counts for a satisfactory job and continued progress.

#### **STARTING THE CUT—GENERAL PRECAUTIONS**

1. Step to the end of the platen and sight under the crossrail and between the housings to be sure of *clearance* of all parts of the work and all holding tools.
2. See that the dogs are set for the proper length of stroke; remember, the feed should be completed before the tool begins to cut.
3. In addition to the gibbs for adjusting the downfeed slide on the tool head and the saddle bearing on the rail, there are *binding screws* that serve to tighten the slide or the saddle to make either one more rigid when its particular feed is being used. Do not fail to see that these binder screws are loosened in one case, tightened in the other, depending upon which feed is to be used.
4. The edge of the work is not always straight, and to avoid the chance of jamming the tool, or possibly spoiling the work, by too heavy a chip at either end of the cut, run the machine the whole length of the stroke before taking a cut, to judge how far to feed the tool in, by hand, before throwing in the power feed.
5. Remove the handle from the feed screw or feed rod when the power feed is being used.
6. Keep your hands away from the tool, and from the work near the tool, while the machine is running.
7. Never use a wrench on any part of the machine, or on any clamp, while the machine is running.
8. Do not brush off the chips when the machine is running, and never brush them in the direction of the ways. Cast-iron scale is hard and gritty; brushing it into the ways will soon destroy the accuracy of these bearings.

**Roughing Cut.** When taking a roughing cut, the combination of feed and depth should be as great as the nature of the work, the

manner in which the work is held, the kind of cutting tool used, and the strength of the machine will permit. When roughing cast iron, care must be taken that the tool does not rub on the scale during any part of the cut. Also in roughing cast iron, in order not to break the corner below the surface at the finish of the cut and thus leave a ragged edge, this corner should be chipped or filed to a bevel of about 45 deg. and to an amount about equal to the depth of the cut.

During roughing, the feeding movement should not take place at the end of the cut because the dragging of the tool on the scale will tend to injure the cutting edge. It should take place at the start of the forward stroke and *before the tool enters the metal*; otherwise the feeding mechanism is unduly strained. Usually allow about 6 in.

**Finishing Cut.** Usually a better finish is produced on *steel* with a fairly light chip and a fine feed. The commercial finish on *cast iron* is produced by using a wide square-nosed tool with a light chip (0.002 to 0.005 in.) and a feed of  $1\frac{1}{2}$  in. or more, depending on the size of the work (see page 58). That is, a better finish is obtained on cast-iron work by a fairly wide scraping cut than is obtained by a deeper cut with a finer feed. This is true on horizontal, vertical, or bevel surfaces. If the tool tends to chatter, the fault may often be remedied and the chatter marks be removed by the use of a tool which will give a shear cut.

**Typical Planer Job.** Directions for planing a bench plate or surface plate:

### The Horizontal Cut

1. **Place the casting on the platen, and level it.**
  - a. If the casting is likely to score the platen when moved around, use heavy cardboard or old belting underneath until the plate is in position.
  - b. Place one or two stops.
  - c. Remove the protecting pieces and level the work, using shims where necessary.
  - d. Tap the work, on the corners especially, and if it sounds hollow it may need further shimming.
2. **Place the poppets and toe dogs and tighten the poppet screws.**

- a. Depending on the width of the plate and the platen, either kind of poppet, *A* or *B* (Fig. 4-6), may be used, possibly *A* on one side and *B* on the other.
- b. Place poppets about 6 or 8 in. apart, usually along the sides and not on the ends.
- c. If lack of room prevents using poppets on the sides, they may be used on the ends, provided care is taken when the cut is being made that the tool cannot hit a poppet at either end of the stroke.
- d. Use a washer under each toe dog, and try to use reasonable judgment when tightening the poppet screws. Refer to Fig. 4-9.

**3. Select the tool.**

If necessary to sharpen the tool, be careful of the front clearance—give it enough, but not too much.

**4. Set the tool.**

- a. If necessary, loosen the clamps and adjust the height of the crossrail until it is 2 or 3 in. above the work.
- b. Let the tool project 2 or 3 in. from the tool post, set it about perpendicular, and clamp it tight.

**5. Set the dogs for the length of stroke.**

Arrange to have the feed take place before the tool begins to cut.

**6. With a chisel or an old file, bevel the edge of the work a little to prevent a ragged corner.**

**7. Bring the tool a little past the edge of the work nearest you and lower it for the proper depth of cut.**

On account of internal stresses and consequent warping of the work, do not remove more than is necessary to get under the scale, otherwise you may not have enough thickness to finish to size.

**8. Arrange for the amount of feed desired.**

**9. Sight along both sides and over the top of the work (hint 1, page 120).**

**10. With the consent of the foreman or instructor you are ready to proceed.**

**11. When one side of the plate is rough-planed it is turned over, carefully shimmed, and the other side roughed.**

It may be necessary to take another roughing cut over the first surface before the edges are roughed, in order to make this surface nearer flat and the plate nearer to the thickness required.

### Vertical Cut

12. **The plate should project about  $1\frac{1}{2}$  in. over the edge of the platen so that the down cutting tool cannot cut into the platen.**
13. **Be sure the swivel head is set on zero.**
14. **Set the apron (top of apron in a direction away from the surface to be cut).**
15. **Set the tool.**
  - a. Have the toolslide moved fairly high up on the head so that it may be fed down a considerable distance without projecting too far below the head (Fig. 4-35).
  - b. Bring the tool over the edge to be cut, in position to take the roughing cut.
  - c. Tighten the saddle-binder screw.
16. **Set the power downfeed.**
  - a. First try the hand feed to be sure the slide is nicely adjusted.
  - b. Probably three or four teeth will be sufficient for beginning. If later it seems too slow, get your instructor's permission to increase the amount of feed.
17. **Before starting the cut, have the setup inspected.**

### Finishing Cuts

18. **Read paragraph on finishing cut.**
19. **Having the work and the machine already set for the downfeed cut, you will probably finish the edges first.**
  - a. The side tool (Fig. 4-35) may be used or the tool shown in (1) or (2) b, Fig. 2-7 (page 31), with a tool bit ground to present a flat surface is very satisfactory.
  - b. Be sure the tool head is set exactly vertical.
  - c. When one edge is finished, set it square with the edge of the planer platen and plane the next edge.



## 20. Finish the horizontal surfaces.

- a. Take great care when clamping the work.
- b. Tool used, Fig. 4-21, page 113.

**Similarity of Shaper Work and Planer Work.** The similarity of the shaper and the planer with regard to several of the details of construction, many of the methods of holding the work, most of the operations, and consequently the cutting tools used, serves to make a knowledge of the one a very great help in understanding the other.

Descriptions and explanations of many of the operations common to both planer and shaper have been given in Chap. 2 and will not be repeated here. Substantially the whole of Chap. 2 is as applicable to planer work as it is to shaper work. It is suggested, therefore, that the student who is not already familiar with shaper work as therein outlined refer to that chapter in connection with his planer work.

**Memoranda.** *The planing of horizontal surfaces, vertical surfaces, rectangular pieces, angular or bevel surfaces, slots, tongues, grooves, keyways, keyseals, and doreails* has been described in the chapter on shaper work beginning on page 25. Consult the index for the particular page.

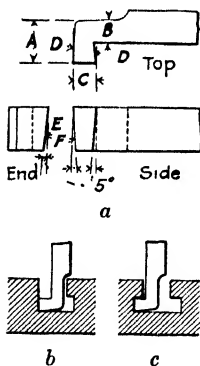


Fig. 4-36. Tools for planing T slots.

*B* must be narrow enough to permit the tool to cut its share of the T slot.

Many T slots in the smaller tables, fixtures, etc., are milled, but in the larger castings they are planed. A slot somewhat narrower than the finished size is planed to the depth required and with sides parallel. The lower part of this slot is then widened with the T-slot

**Planing T Slots; Use of Tool Lifter.** Figure 4-36 illustrates a tool for planing T slots. Two tools (right-hand and left-hand) are needed. The top face is flat (no rake), the cutting edge *C* is given clearance of about 5 deg. on the front *E*, sides *F*, and also from the front, as shown at *D*. As will be observed in parts *b* and *c*, which show, respectively, the start and finish of the cut, the width of the tool *A* cannot be greater than the width of the original slot (see *b*), and the width of the neck

tools, first one side and then the other, as illustrated in *b* and *c*, Fig. 4-36, after which the original slot is carefully planed to exact width. When planing a T slot, it is necessary to lift the tool out of the slot before the return stroke, or *to block it so it cannot lift*. Otherwise, the tool will tend to lift against the shoulder and will rub so hard as to spoil the work and break the tool. In order to obviate the

necessity of lifting the tool by hand each time, a tool lifter, (Fig. 4-37), may be used. There are a number of kinds of tool lifters, but a hasp or hinge fastened back of the tool, as shown, works very well. Sometimes an undercut on the edge of a piece of work is advisable. Such a cut may be made in the same manner as the T slot is cut. Further, the use of the tool lifter is frequently made when a finishing cut is taken over a large surface, as it prevents the rubbing of the tool on the work and serves to prolong the life of the cutting edge.

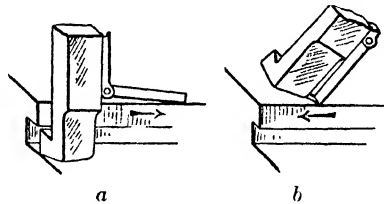


Fig. 4-37. This figure shows tool lifter: (a) cutting stroke; (b) return stroke.

### QUESTIONS ON PLANER WORK I

1. What do you understand by the term "fixture" in machine work? What is the value of a planer fixture?
2. Explain in detail the operation of gripping work in a planer vise. How is the movable jaw held down? When is it fastened down hard? How is it backed up?
3. What advantage has a T-head bolt over a square-head bolt?
4. What is the advantage of the tapped T head?
5. What, in your judgment, is the use of a washer?
6. Describe briefly four kinds of clamps used in holding planer work.
7. What is the difference between "blocking" and "shimming"?
8. What is the advantage of a step block? How would you make a step block with four steps giving eight different heights?
9. Is the height of the block under the clamp an important feature of clamping? Give reason.
10. Is the position of the clamping bolt in relation to the work of any particular importance? Give reason.

11. When is a jack used in setting up a planer job? What precaution should be observed when using a jack?
12. When clamping work down on the platen, what precautions should be taken to avoid springing it?
13. How may a comparatively thin piece be held on the platen and the whole top surface be planed at one setting?
14. What is the real purpose of a "stop" for the work?
15. In what respect is the "toc dog" like the hold-down or gripper?
16. Manufacturers of high-grade machines take a roughing cut on tables, beds, frames, etc., and then pile them in the yard for two or three months, possibly longer. What is the reason for this?
17. Why is it usually advisable to take all the roughing cuts before taking any finishing cut?
18. What do you understand by the term "leveling" in planer work?
19. State three different uses of the surface gage in planer work.
20. Frequently it is necessary to find the low spot on a surface to be planed and then set the tool to get under the scale the first cut. What gage would you use for finding the low spot? For setting the tool?

### QUESTIONS ON PLANER WORK II

1. What is the difference between a right-hand and a left-hand planer tool?
2. What is the effect of too much clearance on a tool?
3. What do you understand by a shear cut?
4. How do you reason the proper feed and a suitable depth of cut for a given planer job?
5. What are some of the reasons against running the tool-head slide down too far?
6. Why is the apron set over when a vertical or an angular surface is being planed?
7. What is the rule for setting the apron when taking a vertical or an angular cut?
8. How do you prevent the breaking of the edge at the end of the cut?
9. How do you oilstone the cutting edge of a square-nosed tool?

# *The Milling Machine*

---

## CHAPTER 5

---

### **Milling-machine Construction**

Milling machines may be described as the class of machine tools in which the metal is removed by causing the work to be fed against a revolving cutting tool called the milling cutter, which has one or more (usually several) cutting edges. There are several ways of holding the milling cutter, which rotates with the machine spindle. It may be bolted directly to the nose of the spindle, or mounted on an arbor, the taper shank of which fits the taper hole in the spindle, or held in a collet or other adapter which fits the spindle. These will be discussed presently.

In all milling machines, cutters of a wide range of shapes and sizes may be used, and provision is made for changing the spindle speeds to accommodate cutters of various diameters, and suitable automatic feeds for the worktable are provided in all except the small (hand) milling machines.

The milling cutter may be made in almost any desired shape, and may be sharpened without having its shape destroyed. Several cutters may be mounted together on the spindle to machine several surfaces at the same time. These features, in connection with the methods available of holding the cutter and the work, permit of a variety of operations that make the milling machine one of the greatest factors in rapid production of duplicate parts, as well as one of the most valuable machines in the general machine shop.

It seems quite proper to differentiate between *factory-production* milling, and *machine-shop* milling—that is, tool- or modelmaking or maintenance work—in much the same way that production turret-lathe work is differentiated from run-of-shop lathe work. The designing and making of the tools and fixtures for production milling, the setting of the machine, and the supervision of the work, are done by

experts who have learned the principles and methods of milling. The production work is done by an operator who has only to know how to load and unload the machine.

Some of the production machines are highly efficient as to quality and quantity of output, their adaptability, and ease in handling. Most of these machines, in various kinds and sizes, are now automatic or semiautomatic. This means, in the fully automatic, for



Fig. 5-1. A group of milling machines in a manufacturing department (*The Brown & Sharpe Manufacturing Company*)

example, that the table feeds may be set for automatic *rapid power traverse*, either direction, for return of table to starting position; for *intermittent* rapid-traverse and cutting feed, as when the surface machined is not continuous; for automatic reverse at each end of the cut, reversing at one end and stopping at the other, or stopping at both ends; and it means that *variable feeds*, for intermediate light or heavier cuts, are automatically controlled.

It is not the purpose of this book to discuss these machines or their production work.<sup>1</sup> They are mentioned here as examples of special

<sup>1</sup> For information about production milling, see *Practical Treatise on Milling*, Brown & Sharpe Manufacturing Company, Providence, R. I., and *A Treatise on*

and special-purpose machines which are all developments of machine-tool units provided with mechanical, electrical, or hydraulic control.

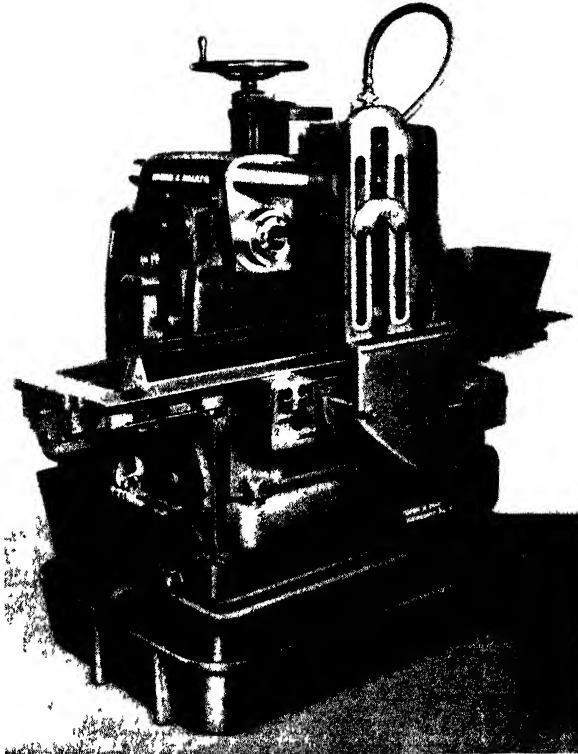
For the beginner in the machinist's trade, the most interesting and profitable experience is obtained by study and practice of the various operations on the standard machine. The principles of cutting tools, cutting speeds and feeds holding the work and the cutter, adjustments, measurements etc., apply to any type or size of machine.

Milling work offers all kinds of jobs, from routine drudgery in the factory to the most particular and interesting work in the machine shop. Of all the machine-shop tools, only the lathe is comparable to the milling machine in the variety of operations. Most boys have to begin with the simple jobs on any machine, but the ambitious boy who is determined to learn will soon be too valuable to remain with the drudges. Running the milling machine intelligently involves a considerable knowledge of the following things:

1. The construction of the machine, that is, the names and uses of the parts, the location of the oil holes, the operations of the speed and feed mechanisms, and the various adjustments.
2. The construction, use, and value of the various attachments and accessories.
3. The cutters, their names and uses, how they are properly held in the machine, and how they are sharpened.
4. The efficient speeds and feeds for various kinds of work.
5. The methods of holding the work.
6. The setup that is mechanically right.
7. The ever-present need for carefulness—*safety first*—around a revolving milling cutter.

It is suggested that the student read through this chapter and the next, to get the general idea of the machine and of the cutting and holding tools used, then go back and study the subjects in detail. Some parts will, of course, require more study than others; the purpose is to get such knowledge and understanding as will help in doing the milling job. Start with the idea that this machine with its great possibilities is simple enough, in any of its operations, if one understands the few fundamental principles.

**Types of Milling Machines.** There are two distinct types of milling machines—the bed type, which has a vertical adjustment of the spindle, and the column-and-knee type, which has a vertical adjustment of the worktable. Each type is made in many modifications and several sizes. The adjustable-spindle machine, with its



**Fig. 5-2.** Bed-type milling machine. (*The Brown & Sharpe Manufacturing Company*)

solid worktable base, is no doubt more rigid for a given size than is a machine with the adjustable support for the worktable. However, these machines are not nearly so easily and quickly adjusted or so adaptable for a variety of work as the machines having the adjustable-worktable support.

*Bed Type.* The original milling machine was of the type having a vertical adjustment of the spindle. The natural development has produced machines of this same general type in a wide range of sizes, and of great power and rigidity. Also the increased flexibility and ease of operation are notable. The cutters, of high-speed steel, or carbide-tipped, are made in a variety of kinds and sizes that offers a cutter for every purpose.

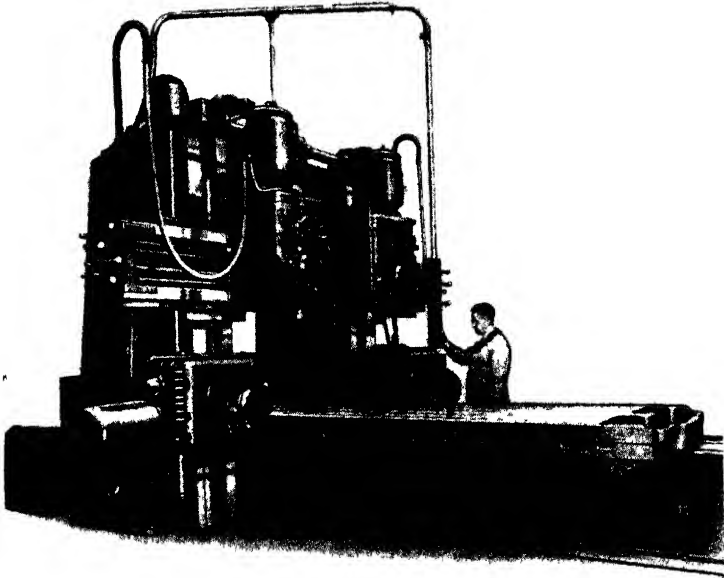


Fig. 5-3. Planer-type milling machine (Gidding & Lewis)

All those of the bed type are more particularly *manufacturing* machines. They are used in milling a large number of duplicate pieces. Sometimes an unskilled man or boy can operate several machines after they have been "set up" by a skilled mechanic. That is, after the machinist has made the adjustments to take the desired cuts, the operator can remove from one machine a piece that has been milled, and can put in the next piece, while the other machines are running. Figures 5-2 and 5-3 show two kinds of adjustable-spindle milling machines designed especially for manufacturing purposes.



*Profiling Machine.* This machine (Fig. 5-4) is practically a milling machine of the adjustable-spindle type with the spindle held in a vertical position. The special characteristic of the profiler is the guiding of the cutter, by means of a guide pin or "former pin,"

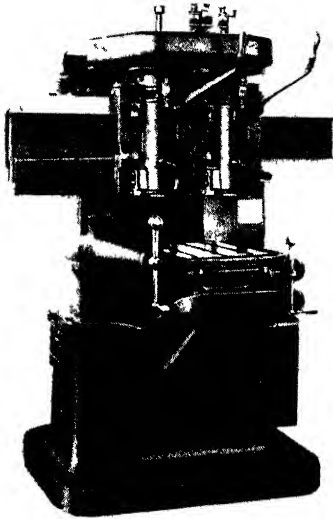


Fig. 5-4. Profiling machine. (Pratt & Whitney)

which is held against, and follows, the outline or *profile* on a template or guide block. The guide pin is fixed in relation to the cutter, and the template and the work are fastened to the worktable in exact relation to each other; thus if the guide pin follows a predetermined profile, straight or curved, on the template, the cutter will cut the given profile on the work. Also, if horizontal surfaces in different planes are to be finished, as, for example, bosses of different heights on a casting, a guide block with the required *steps*, exact distances one above the other, may be used to guide the cutter. The profiler is used in the making of small parts of irregular

shape, as in the manufacture of guns, sewing machines, etc.

The cutter is held in the spindle by a drawbar. Several spindle speeds are available for different sizes of cutters and different materials.

The spindle and the guide-pin holder are carried in a vertical slide on the head, which is, itself, carried on a sliding surface on the cross-rail of the machine. The *spindle slide* may be moved by a lever vertically through  $4\frac{1}{2}$  in. Positive vertical adjustable stops are provided, each having a dial graduated to read in thousandths of an inch. The spindle slide may be locked in any desired position.

The *head slide* is moved on the crossrail by a lever at the right hand of the operator through a rack and pinion. The *table* may be moved at right angles to the spindlehead slide by a lever at the left.

The table is controlled by the operator's left hand, and the head slide on the crossrail by his right hand; thus the guide pin is kept against the template as it moves along the guiding edge. For the cuts in different horizontal planes, the spindle is locked by a suitable lever exactly in place, as indicated by positioning the guide pin on the guide block.

The figure shows a two-spindle machine. By means of two spindles, a roughing and finishing cut may be taken in one setting of the piece.

**Milling Machines Having Vertical Adjustment of Worktable.** A large proportion of milling machines are of the type having the worktable adjustable for height. The saddle on which the worktable rests is supported on a knee which may be moved vertically on a finished face on the front of the column. The knee may be rigidly clamped in any desired position. This type of machine is classified as to kind as: *universal*, *plain*, and *vertical*.

*Universal Milling Machine* (Fig. 5-7). The universal milling machine was invented in 1862 by Joseph R. Brown, one of the founders of the Brown & Sharpe Manufacturing Company. It is so constructed that the table may be swiveled to a considerable angle in a horizontal plane to permit the milling of spiral (twisted) grooves, such as are cut in twist drills, spiral mills, etc.

The worktable may be moved longitudinally, by hand or automatically, in either direction; this is called the longitudinal feed or, more often, "table feed." The saddle is so arranged on the knee that it may be moved transversely by hand or power in either direction; this is called the crossfeed. The vertical movement of the knee may be used as a vertical hand feed in either direction, and in the larger sizes automatic vertical feed is provided.

Numerous attachments are built for the universal milling machine which permit a very large number of distinct operations. It is essentially a toolmaker's milling machine and is one of the most important, most adaptable, and most interesting machines in the shop. Refer to Fig. 5-5.

*Plain Milling Machine* (Fig. 5-6). The plain milling machine is a simplified model of the standard knee-type milling machine. It has largely displaced the bed type for milling a considerable variety of manufactured work. It is very similar in appearance and construc-

tion to the universal milling machine, differing chiefly in that it lacks the swivel-table construction. Many of the attachments made for the universal milling machine can be used on the plain milling machine.

*Vertical-spindle Milling Machine.* This machine is so called because the axis of rotation of the spindle is vertical. Except for the position of the spindle, it is similar in construction and opera-

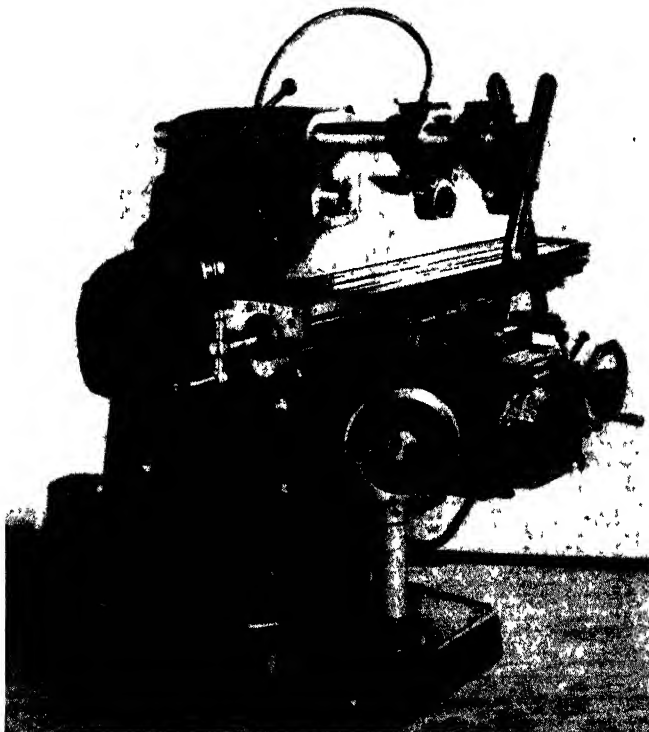


Fig. 5-5. A group of milling machines in a toolroom department. (*The Taft-Pierce Manufacturing Company*)

tion to the plain milling machine. For many end-milling and face-milling operations it is more adaptable than the machine with the horizontal spindle, because of the fact that the cutter and the surface being machined are in plain view, instead of over in back of the work.

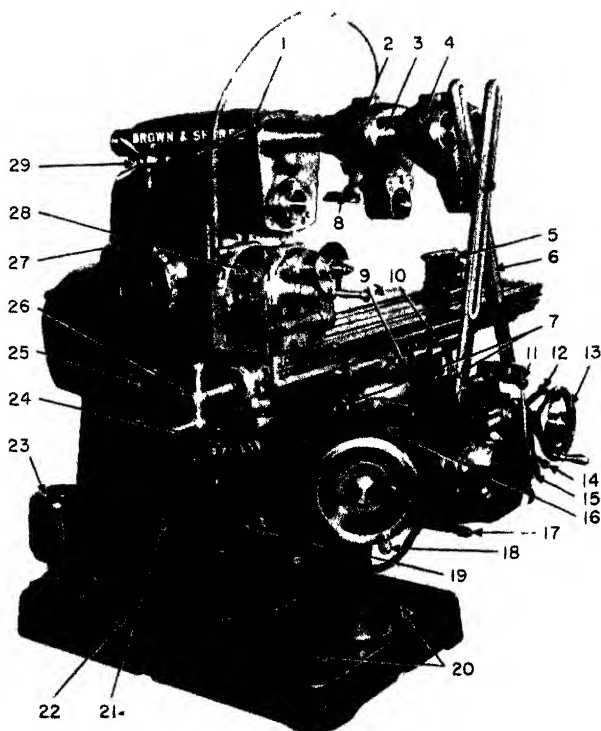
**Parts of the Brown & Sharpe Universal Milling Machine.** On the following pages is illustrated and described an example of the column-and-knee type of milling machine—the *Brown & Sharpe Universal Milling Machine*. Generally speaking, all makes of milling machines of this class have similar features of construction and opera-

ation. The spindle-speed changes are controlled by levers or dials, operating other levers, yokes, and forks, to slide clusters of gears for the various gear runs. The different table feeds—longitudinal, transverse, and vertical—are controlled by levers in a similar manner.



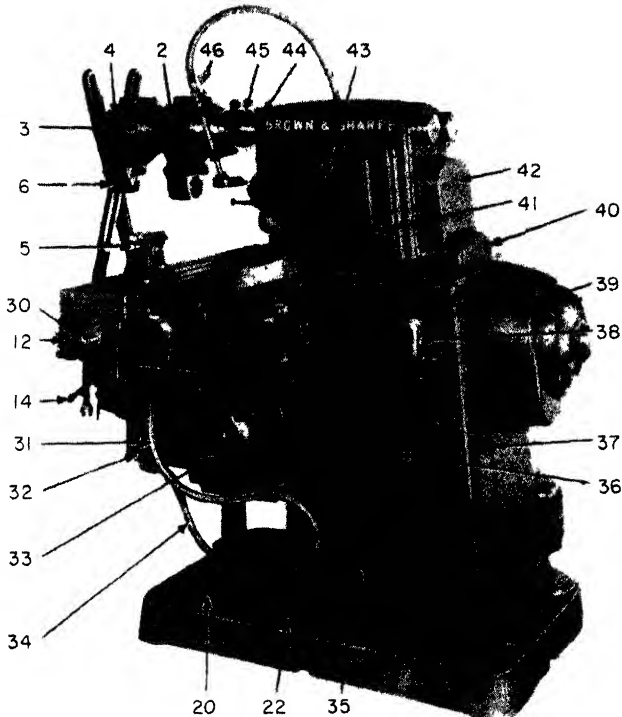
**Fig. 5-6.** No. 0 plain milling machine. (*The Brown & Sharpe Manufacturing Company*)

All of these machines now have the standardized spindle nose, use the same kinds of cutters and cutter holding tools, the same vises, and similar types of attachments. The beginner should learn the name and function of each part of the machine on which he is working.



- |   |  |
|---|--|
| 1. Machine start-stop lever   | 13. Transverse-adjustment handwheel          |
| 2. Inner arbor yoke   | 11. Vertical-feed-control lever              |
| 3. Overarms   | 15. Feed-selector lever and dial             |
| 4. Outer arbor yoke   | 16. Saddle-clamp lever                       |
| 5. Universal spiral-index center foot-stock                         | 17. Knee-clamp lever                         |
| 6. Adjustable arm braces  | 18. Vertical-adjustment handwheel            |
| 7. Table-swivel clamp screw (at front) and clamp nut (under saddle) | 19. Knee oil-reservoir sight gage            |
| 8. Coolant distributor  | 20. Coolant-reservoir cover plates           |
| 9. Table-clamp lever  | 21. Storage compartment for head-stock gears |
| 10. Longitudinal feed-control lever                                 | 22. Coolant-reservoir strainer               |
| 11. Power fast-travel lever   | 23. Motor-driven centrifugal coolant pump    |
| 12. Transverse feed-control lever                                   | 24. Sight indicator for knee-oiling system   |

**Fig. 5-7.** The Brown & Sharpe No. 2 universal milling machine. (a) Front  
luring Company)



- |  |  |
|--|--|
| 25. Filler and sight indicator for oil reservoir in column | 35. Electrical-control compartment                             |
| 26. Longitudinal adjustment hand-crank                     | 36. Coolant-pump switch  |
| 27. Speed-selector lever and dial                          | 37. Spindle-motor reversing switch                             |
| 28. Universal spiral-index center headstock                | 38. Main disconnect switch                                     |
| 29. Spider for overarm adjustment                          | 39. Spindle motor  |
| 30. Power take-off for driving rotary attachment           | 40. Spindle jog button   |
| 31. Flexible coolant-return pipe                           | 41. Lever-operated main start-stop switch (behind cover plate) |
| 32. Feed-clutch solenoid compartment                       | 42. Hinged guard for draw-in bolt                              |
| 33. Feed and fast-travel motor                             | 43. Pad for storing attachments                                |
| 34. Electrical conduit to knee                             | 44. Overarm clamp lever  |
|  | 45. Adjustable coolant-distributor bracket                     |
|  | 46. Coolant valve  |

view and (b) rear view with parts identified. (*The Brown & Sharpe Manufac-*

Figure 5-7 shows the Brown & Sharpe universal milling machine: (a) the front view and (b) the rear view. The names and functions of the parts are given below:

1. *Machine Start-stop Lever*. Lever to start and stop the machine.
2. *Inner Arbor Yoke*. Yoke between column and outer arbor yoke, used to support the arbor on the inside.
3. *Overarms*. Used for positioning the inner and outer arbor yokes; this machine has two overarms.
4. *Outer Arbor Yoke*. Yoke at end of overarm used for the outer support of the arbor.
5. *Universal Spiral-index Center Footstock*. Footstock (at times, called a tailstock) used with the dividing or indexing head.
6. *Adjustable Arm Braces*. Added support for the overarm. They are adjustable.
7. *Table-swivel Clamp Screw (at front) and Clamp Nut (under saddle)*. Screw used to clamp swivel table.
8. *Coolant Distributor*. Nozzle from which the cutting coolant is fed to work.
9. *Table-clamp Lever*. Lever used to clamp the table. Longitudinal power feed is locked out when the table is clamped.
10. *Longitudinal Feed-control Lever*. Lever used to control the direction of movement of the table; controls longitudinal feed.
11. *Power Fast-travel Lever*. Lever gives power fast travel in any direction of feed engaged, with spindle and feed drive either running or stopped.
12. *Transverse-feed-control Lever*. Lever controlling the amount of transverse feed.
13. *Transverse-adjustment Handwheel*. Used to adjust transverse feed; adjustable dial reads to 0.001 in.
14. *Vertical-feed-control Lever*. Used to control the vertical feed of table.
15. *Feed-selector Lever and Dial*. Single lever selects all feed rates. One turn in either direction gives feed change. Dial shows rate engaged.
16. *Saddle-clamp Lever*. Lever used to clamp the saddle in place.
17. *Knee-clamp Lever*. Knee is quickly clamped by single lever from operating position; lever used to clamp the knee.

18. *Vertical-adjustment Handwheel.* Handwheel used to adjust the vertical feed of table; automatically disengaged when power feed is engaged.
19. *Knee Oil-reservoir Sight Gage.* Shows level of oil in the knee.
20. *Coolant-reservoir Cover Plates.* Plates used to cover the reservoir of the coolant used on the machine; keep chips and dirt out, thus keeping the coolant clean.
21. *Storage Compartment for Headstock Gears.* Storage place for change gears of the universal spiral-index center.
22. *Coolant-reservoir Strainer.* Coolant reservoir in base of machine has large clean-out openings in top, covered by removable plates and strainers; used to keep chips and dirt out of lubricant.
23. *Motor-driven Centrifugal Coolant Pump.* Used to force the coolant through the nozzle (8); starts and stops with the machine spindle; can be stopped separately by switch at side of column.
24. *Sight Indicator for Knee-oiling System.* Indicator showing level of oil.
25. *Filler and Sight Indicator for Oil Reservoir in Column.* Shows level of oil in column; shows operation of automatic oiling systems for all gears and bearings in column.
26. *Longitudinal-adjustment Handcrank.* Crank turned by hand to adjust the longitudinal position of table.
27. *Speed-selector Lever and Dial.* Single lever selects all speeds. One turn in either direction gives speed change. Dial shows rate engaged; eighteen rates of spindle speeds are provided, 30 to 1,200 r.p.m. in either direction. Always stop the machine before changing speed.
28. *Universal Spiral-index Center Headstock.* Used for all types and kinds of indexing (see Chapter 9, The Index Head and Indexing Operations).
29. *Spider for Overarm Adjustment.* Used to move the overarms in or out of the column.
30. *Power Take-off for Driving Rotary Attachment.* When rotary attachment is used, this is used for power.
31. *Flexible Coolant-return Pipe.* Flexible pipe used for the return of the coolant to the reservoir.
32. *Feed-clutch Solenoid Compartment.* Compartment containing electrical controls.



33. *Feed and Fast-travel Motor.* Provides power for all feed and fast-travel movements, independent of spindle drive.
34. *Electrical Conduit to Knee.* Conduit containing electrical wires to knee.
35. *Electrical-control Compartment.* Contains all electrical controls for the machine.
36. *Coolant-pump Switch.* Starts and stops the coolant pump.
37. *Spindle-motor Reversing Switch.* Switch used to reverse the direction of revolution of the motor that revolves the spindle; reverses spindle.
38. *Main Disconnect Switch.* Sort of a safety switch that disconnects all electrical switches in the electrical compartment.
39. *Spindle Motor.* Motor driving the spindle.
40. *Spindle Jog Button.* If occasional difficulty should be encountered in changing the speed, a touch of this jog button will remedy the situation.
41. *Lever-operated Main Start-stop Switch (behind cover plate).* Switch controlled by part 1, machine start-stop lever.
42. *Hinged Guard for Draw-in Bolt.* Guard for draw-in bolt.
43. *Pad for Storing Attachments.* Used for storing some of the attachments used on the machine.
44. *Overarm-clamp Lever.* Used to clamp the overarms.
45. *Adjustable Coolant-distributor Bracket.* Bracket used to hold coolant distributor; is adjustable.
46. *Coolant Valve.* Controls the rate of flow of the coolant.

The more important parts of the B & S Universal milling machine are further described as follows:

*Spindle Reversing Switch* (Fig. 5-8). The direction of spindle rotation is controlled by a reversing switch at the right rear of the machine, the setting for right-hand and left-hand rotation being shown on the switch plate. With the switch at "off" position, only the spindle motor is disconnected. *Stop the machine before operating the reversing switch.*

*Controls and Adjustments at Front of Machine* (Fig. 5-9): **HAND ADJUSTMENTS.** Longitudinal, transverse, and vertical hand adjustments have adjustable dials reading to 0.001 in. To set a dial, turn the adjacent knurled clamp nut counterclockwise to release the dial;



Fig. 5-8. Spindle-reversing switch. (*The Brown & Sharpe Manufacturing Company*)

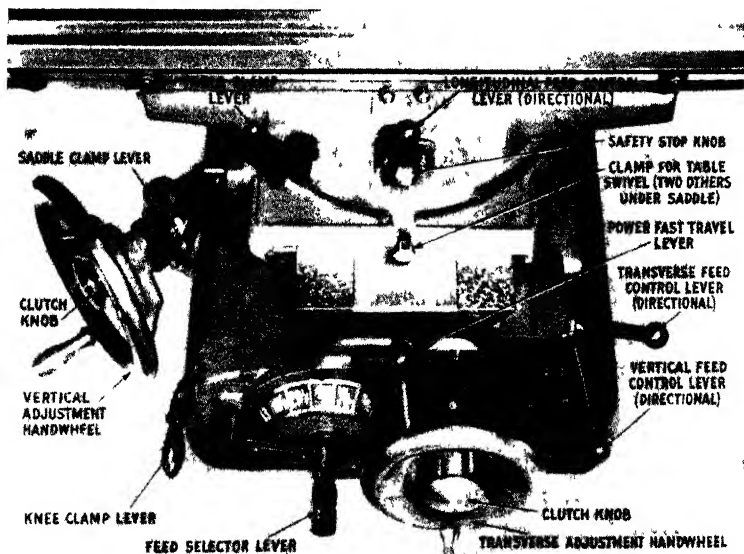


Fig. 5-9. Controls and adjustments at front of machine. (*The Brown & Sharpe Manufacturing Company*)

turn the adjustment crank or handwheel in the desired direction enough to take up the normal backlash; then turn the dial to the desired setting and tighten the clamp nut.

Each of the three adjustments is automatically disengaged when the respective power feed is engaged.

*Adjustment Clamps.* Clamps for the three adjustments are shown in Fig. 5-9. To clamp the table, pull the table-clamp lever upward;

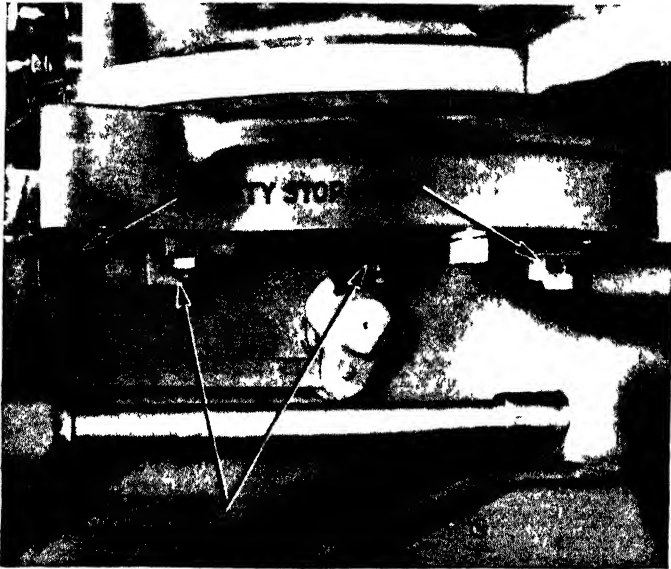


Fig. 5-10. Transverse feed-trip dogs (*The Brown & Sharpe Manufacturing Company*)

to clamp the saddle, push the saddle-clamp lever downward; and to clamp the knee, pull the knee-clamp lever to the left.

The angular adjustment of the table is clamped by a hexagonal-headed screw at the lower front of the saddle, shown in Fig. 5-9, and by a clamp bolt in a circular T slot under each end of the saddle. Tighten all three clamps before starting a cut.

*Selecting Rate of Feed.* Eighteen rates of power feed are provided— $\frac{1}{2}$  in. to  $20\frac{1}{4}$  in. per minute (with a 60-cycle motor). To change the feed rate, turn the feed-selector lever on the front of the knee

(Fig. 5-9). The lever can be rotated in either direction, and each complete turn gives a change in feed, the rate engaged being shown in inches per minute on the large rotating dial.

*Feed-control Levers.* Longitudinal, transverse, and vertical feeds are each controlled and engaged by a single lever. All feed-control levers are directional, so that to engage feed in a given direction the operator simply moves the proper lever (longitudinal, transverse, or vertical) in the desired direction of feed. For example, to engage left hand feed of the table, throw the longitudinal feed-control lever to the left; to engage upward feed of the knee, pull the vertical-feed-control lever upward; and so on. These levers are identified in Fig. 5-9.

*Fast Power Travel.* Power table movement in any direction—longitudinal, transverse, or vertical—can be instantly speeded up by means of the power fast-travel lever on the front of the knee, Fig. 5-9. Fast travel is engaged by pulling the lever to the left, and the original feed movement is resumed automatically when the lever is released.

*Trip Dogs.* Adjustable trip dogs are provided for longitudinal, transverse, and vertical power movements in each direction. In addition, safety stop dogs are fastened at both ends of each path of travel. The longitudinal dogs are on the front of the table, while the transverse

and vertical dogs are located under the right-hand side of the saddle and on the right-hand side of the column, as shown in Figs. 5-10 and 5-11, respectively.

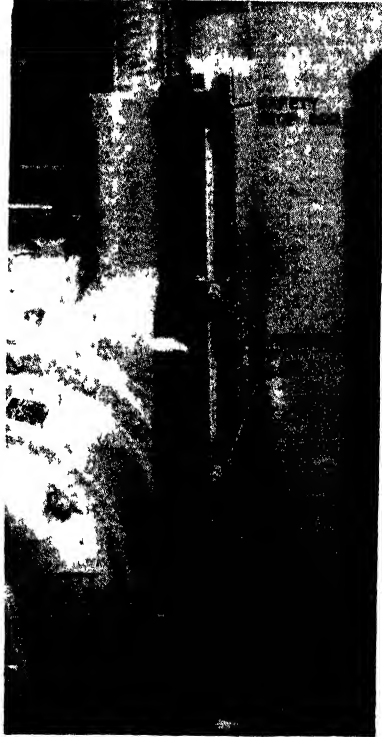


Fig. 5-11. Longitudinal stop dogs. (The Brown & Sharpe Manufacturing Company)

When longitudinal or transverse feed has been disengaged by a dog, power movement in the opposite direction can be engaged by the respective feed-control lever. When the vertical feed has been tripped out by a dog, the knee must be moved by hand a short dis-

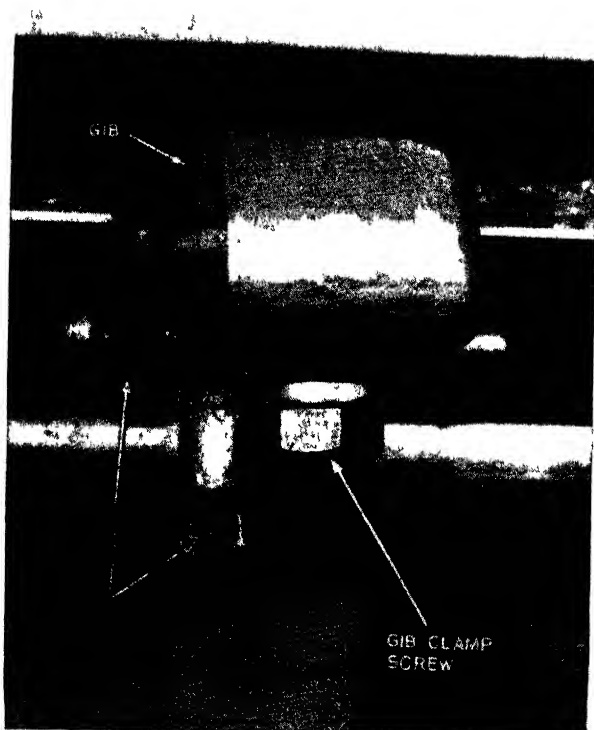


Fig. 5-12. Table stops. (*The Brown & Sharpe Manufacturing Company*)

tance in the opposite direction, until the plunger is off the dog before engaging the power movement.

*Table Stops.* The two positive stops for longitudinal movement of the table are clamped onto the front table way by means of a gib and clamp screw, as illustrated in Fig. 5-12. Fine adjustment of each stop is provided by a screw which bears against the saddle when the table reaches the desired stopping point, and a clamp screw maintains the adjustment.

Before starting the machine, the operator should make sure that the power feed will be disengaged by a feed-trip dog before the stop comes in contact with the saddle.

**Attachments for Milling Machines.** By means of various attachments, which have come to be recognized as practically standard equipment for the column-and-knee type of milling machine, many jobs can be done more quickly and conveniently than otherwise, and, in addition, a large variety of operations may be performed on one machine which, without the attachments, would require several kinds of machines.

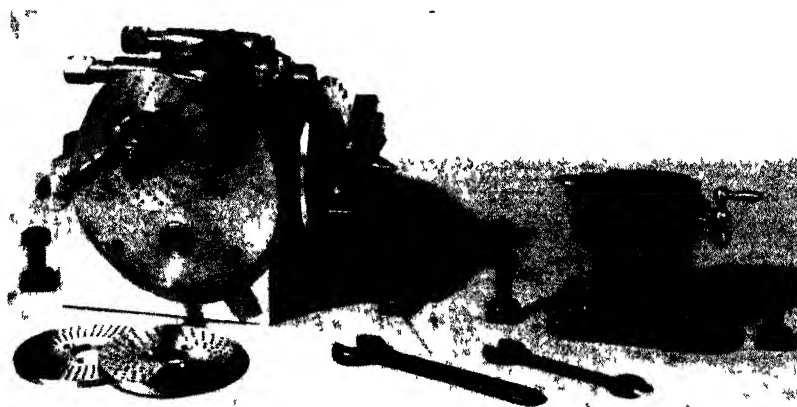


Fig. 5-13. The index centers consisting of the index or dividing head and tailstock (*The Brown & Sharpe Manufacturing Company*)

The manufacturers of milling machines furnish attachments that are interchangeable on their own make of machines of the same size, and many of these attachments, especially those which are clamped to the table, may be used on different sizes of machines or even on different makes of machines.

*Index Centers* (Fig. 5-13). The index centers, consisting of the index head and tailstock, comprise the most important attachment for the milling machine. The mechanism of the head is described in Chapter 9, page 250.

*Raising Block* (Fig. 5-14). This block is used when it is required to locate the dividing head at  $90^\circ$  deg. from its regular posi-

tion on the table. It is provided with T slots for the dividing-head bolts. In addition, the T slots are accurately milled to fit the dividing-head keys and are parallel to a finished edge of the block.



Fig. 5-14. The raising block. It shows the head held on the raising block and set around 90 deg.

*Tilting Table* (Fig. 5-15). In the milling of tapers of any description, this attachment is very useful. The vise, the index centers, or the work may be clamped onto this table.

*Vertical-spindle Milling Attachment* (Fig. 5-16). The spindle in this attachment can be set and securely clamped at any angle in a vertical plane, the position being indicated by graduations in degrees. This attachment offers an easy means of doing work which would be inconvenient to do with the cutter held in the main spindle and, more important, makes it possible to produce work that would otherwise require a vertical-spindle milling machine.

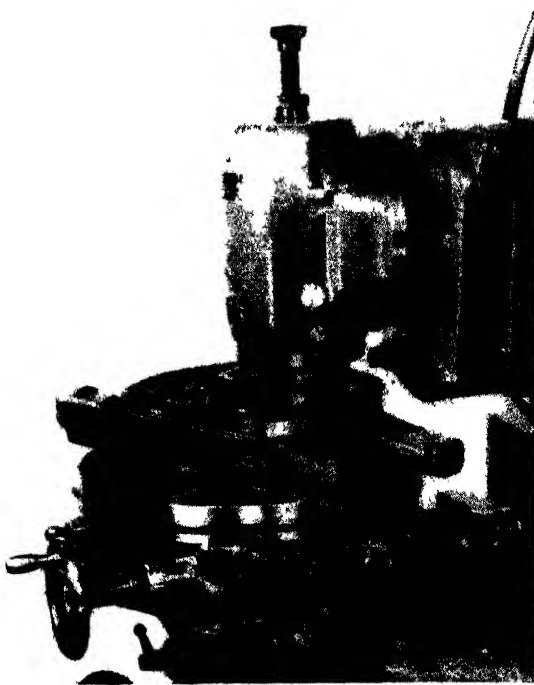
*Universal Milling Attachment* (Fig. 5-17). The spindle of this attachment may be set and securely clamped at any angle in either a vertical or a horizontal plane, the positions being indicated on the swivel plates by graduations in degrees. Besides having the advan-



Fig. 5-15. Tilting table. (The Brown & Sharpe Manufacturing Company)

tages of the regular vertical-spindle attachment, this attachment offers the advantages to be obtained by the use of a second swivel at right angles to the first, making it possible to take milling cuts at any angle in either plane.

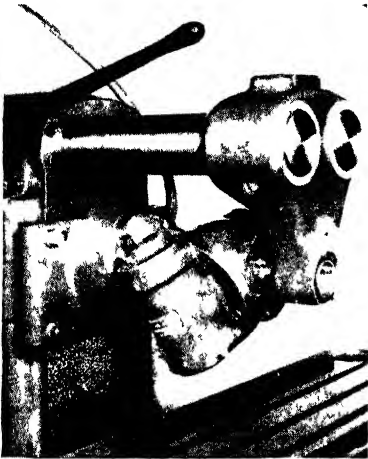
*Slotting Attachment* (Fig. 5-18). The tool-holding slide has a reciprocating motion and is driven by an adjustable crank which allows the length of the stroke to be changed. The head may be swiveled to 90 deg. either side of the center, the position being indicated by graduations in degrees. This attachment is very useful for cutting keyseats and for finishing the sides of square, oblong, or even



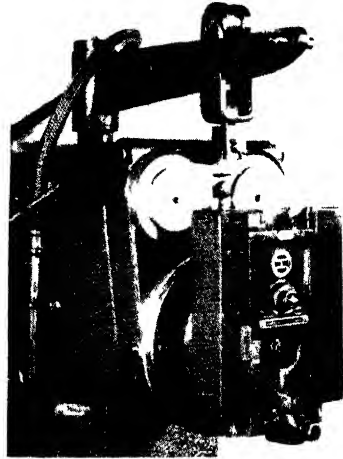
**Fig. 5-16.** The vertical-spindle attachment and the rotary attachment in use (*The Brown & Sharpe Manufacturing Company*)

irregularly shaped holes, such as are frequently needed in medium-sized machine or tool work and especially in making blanking dies. A set of cutting tools which consist of various sizes of rounds, squares, and special shapes is furnished with the attachment. These tools have cylindrical shanks and are secured in the holder by means of a setscrew. It is a simple matter to make special tools of the shape and size required.





**Fig. 5-17.** The universal milling attachment (*The Brown & Sharpe Manufacturing Company*)



**Fig. 5-18.** The slotting attachment (*The Brown & Sharpe Manufacturing Company*)



**Fig. 5-19.** The circular milling or rotary attachment (*The Brown & Sharpe Manufacturing Company*)

*Circular Milling or Rotary Attachment* (Fig. 5-19). An especially valuable attachment for vertical milling machines, or for horizontal machines when used with a vertical-spindle attachment or a slotting attachment, is this circular milling or rotary attachment. The circular table is rotated by means of an enclosed worm and worm wheel. The smaller size is provided with hand feed only, but the larger size

is driven from the feedbox and is provided with an automatic feed trip and adjustable feed-trip dogs. The illustration in Fig. 5-16 shows this attachment in actual use.

*High-speed Milling Attachment* (Fig. 5-20). Small milling cutters are efficient only when operated at the proper cutting speed. This attachment offers a means of obtaining a speed from four to six times the regular spindle speeds, since motion is transmitted from a gear fastened to the machine spindle to a pinion about one-fourth to one-sixth as large on the attachment spindle. The illustration shows the one generally used for horizontal-spindle milling machines.

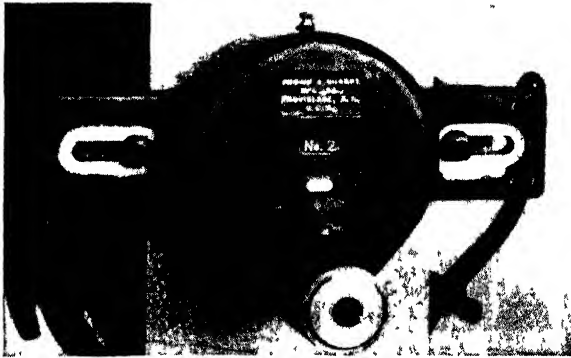


Fig. 5-20. The high-speed milling attachment for horizontal-spindle milling machines. (*The Brown & Sharpe Manufacturing Company*)

*Rack Milling Attachment* (Fig. 5-21). This is an almost indispensable attachment if racks more than 10 or 12 in. are to be cut. The cutter is mounted on the end of a hardened-steel spindle, which is driven parallel to the table T slots by spur and bevel gears.

At the left of the vise for holding the rack may be seen the rack-indexing attachment. It consists of a bracket fastened to the table and carrying change gears for gearing to the feedscrew, and a locking disk. When it is properly geared, one or more whole turns of the disk, to a locking pin, will advance the table an amount equal to the pitch of the rack tooth.

**Vertical Milling Machine.** This machine is similar to the plain milling machine (which has a horizontal spindle) except for the head, which has a vertical spindle. All other operating parts are the same and therefore will not be described here.

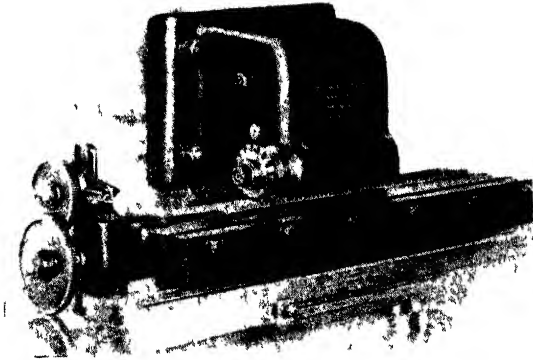


Fig. 5-21. The rack milling attachment. (*The Brown & Sharpe Manufacturing Company*)

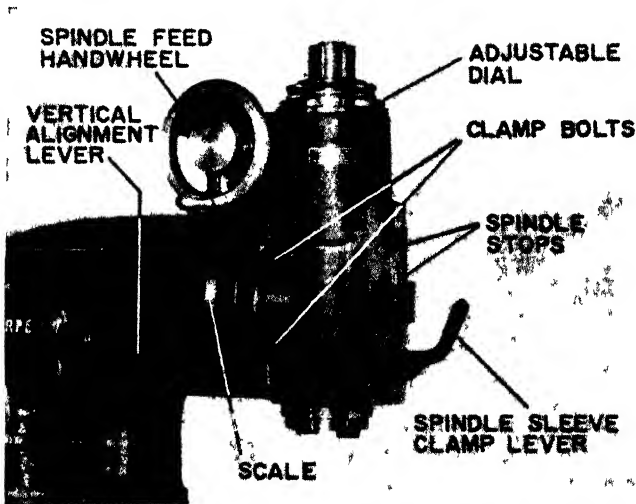


Fig. 5-22. The head of the vertical milling machine with its parts identified (*The Brown & Sharpe Manufacturing Company*)

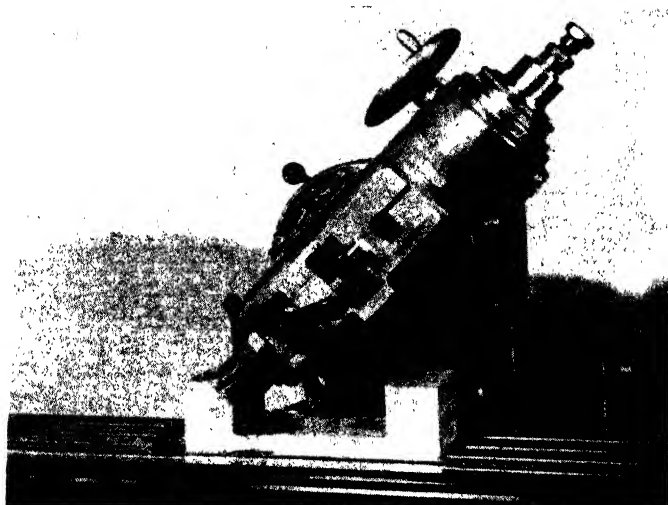


Fig. 5-23. Head of vertical milling machine set at an angle for first operation in cutting an angle on a piece. (*The Brown & Sharpe Manufacturing Company*)

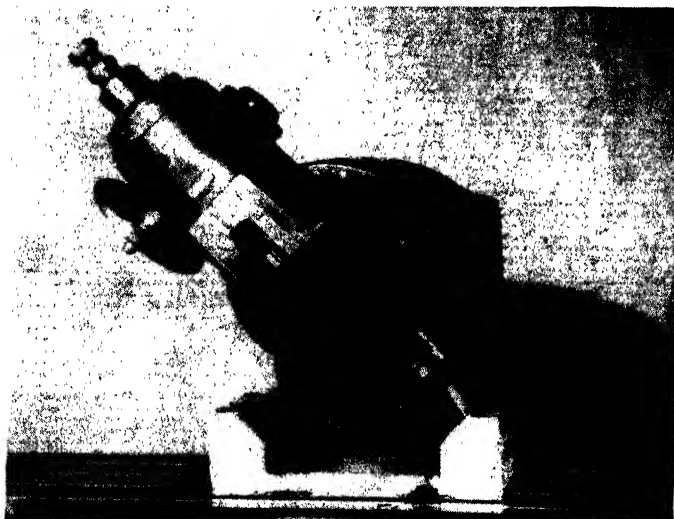


Fig. 5-24. Head set for second operation in cutting an angle of the same piece (Fig. 5-23) on the other side without having to relocate the work. (*The Brown & Sharpe Manufacturing Company*)

The important part of this machine is the *head*, the parts of which are identified in Fig. 5-22. A brief description follows.

*Spindle Head* The spindle head can be set at any angle up to 90 deg. each side of zero in a vertical plane parallel to the table ways.

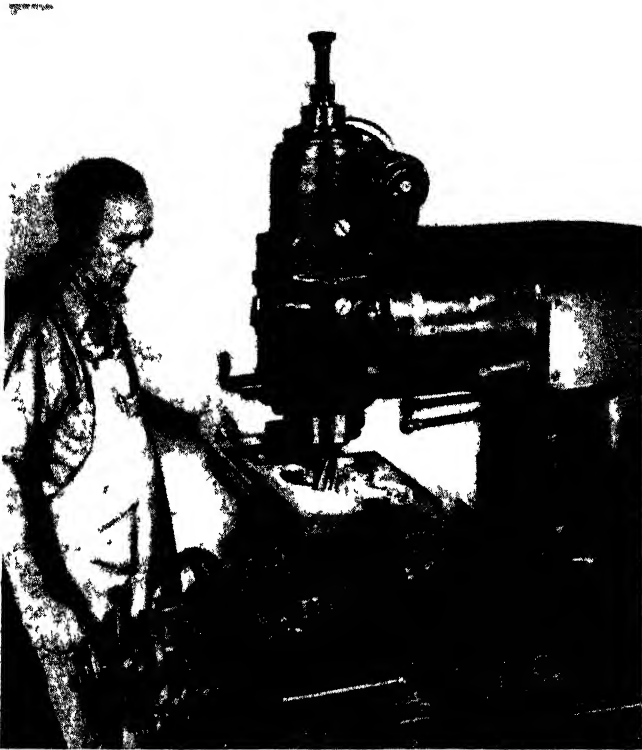
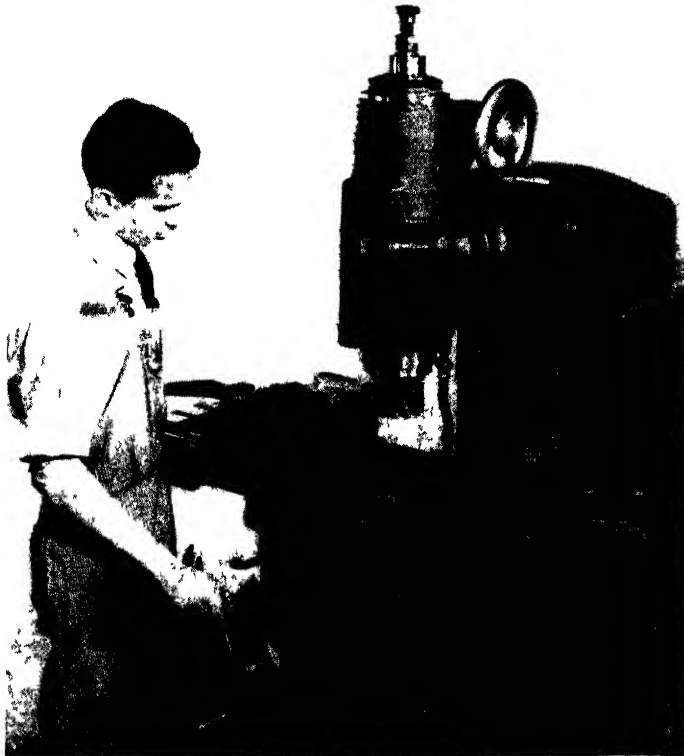


Fig. 5-25. Milling an irregular outline in the vertical miller (*The Brown & Sharpe Manufacturing Company*)

A scale reading to half degrees shows the angular setting from either side of the head.

In setting the head at an angle, first push the vertical alignment lever to the rear, to withdraw the alignment plunger from the head. Then loosen the four clamp bolts at the front of the head (two at each side). Swing the head to the desired angle and tighten the four clamp bolts. In bringing the head to a position considerably away

from the vertical, do not exert much more force than is necessary to move the head, as too hard a pull might cause the head to swing down and hit the table.



**Fig. 5-26.** Face-milling on the vertical miller. (*The Brown & Sharpe Manufacturing Company*)

If advantage is taken of the adjustments of the machine, surfaces can often be milled or holes drilled at various angles without relocation of the work on the table.

To set the spindle vertical, first bring the head to approximately zero setting by the angular graduations; then pull the vertical alignment lever forward, jiggle the head a few times to seat the plunger, and tighten the four bolts.

*Spindle Feed.* A 3-in. axial movement of the spindle is provided by the spindle-feed handwheel. To feed the cutter toward the work, turn the top of the handwheel toward the front of the machine; and to withdraw the cutter, turn the top of the handwheel toward the

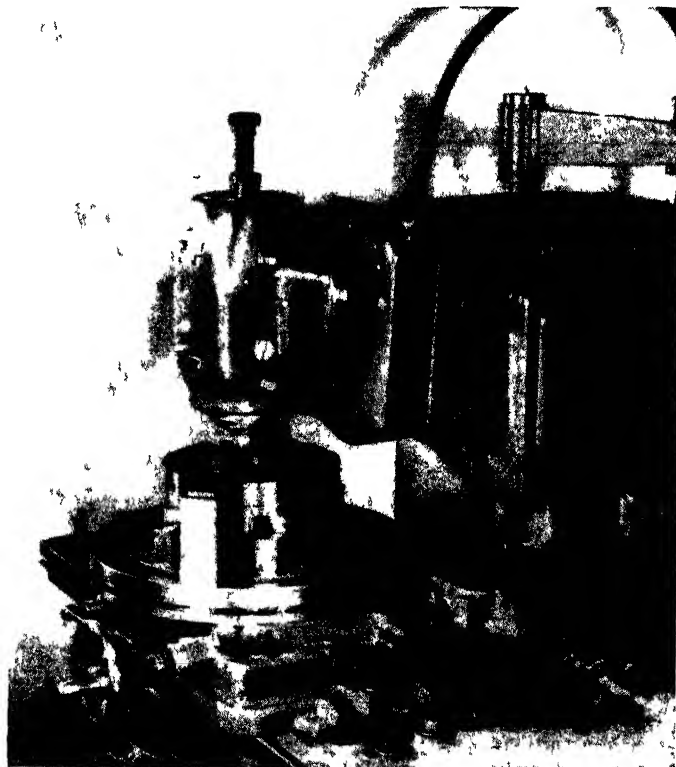


**Fig. 5-27.** Step-milling using a turret-type spindle head on a vertical miller. (*The Brown & Sharpe Manufacturing Company*)

rear of the machine. Graduations reading to 0.001 in. on the adjustment dial at the top of the head permit fine axial adjustment, and the spindle sleeve can be clamped at any point at the lower front of the head.

When the head is set at an angle, it is usually best to use the handwheel on the upper side of the head.

**Typical Operations on the Vertical Milling Machine.** Figures 5-23 and 5-24 show a typical sequence of operations performed without relocation of the work on the table. By this method of leaving the work clamped and taking advantage of the adjustments of the



**Fig. 5-28.** A rotary attachment used on a vertical miller (*The Brown & Sharpe Manufacturing Company*)

machine, these surfaces can be milled with the assurance of correct angular relationship.

Figure 5-25 shows the milling of irregular outlines due to the easy hand manipulation of the table. The illustration shows the operator coordinating the transverse and longitudinal movement of the table so that the proper area in the surface of the piece can be machined.



Figure 5-26 shows face milling, another typical job on the vertical milling machine. Work is loaded in one vise while being milled in the other, and fast travel is used to jump the gap between the two pieces, thus saving time in the operation.

Step milling of production jobs, such as the one shown in Fig. 5-27, is easily accomplished with the aid of the turret-type spindle stop. This equipment provides a simple means of securing accurate duplication in machining parts to one, two, three, or four depths.

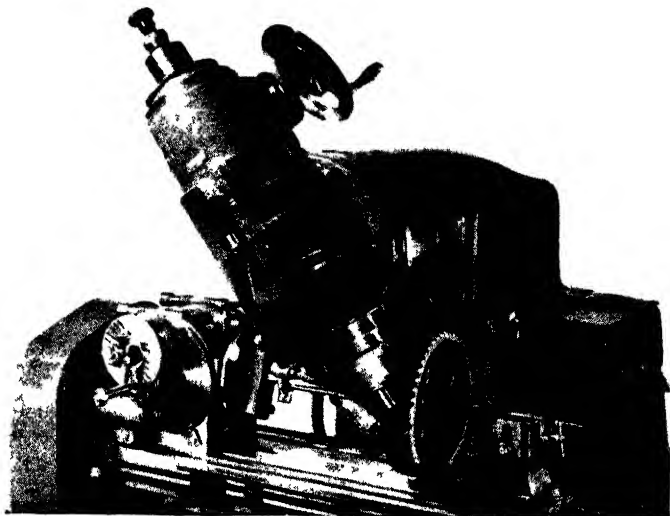


Fig. 5-29. Cutting a spiral gear. (*The Brown & Sharpe Manufacturing Company*)

The turret mechanism permits quick indexing, while the dial indicator assures precision in setting the spindle for depth of cut.

A rotary attachment can also be used in the vertical milling machine (Fig. 5-28). When used, this attachment makes possible a variety of rotary milling operations, such as milling segments of circles, circular slots and cams.

The gear-cutting job (Fig. 5-29) is typical of the spiral work that can be done on the vertical machine, using universal spiral index centers. The spindle head is swiveled to the angle of the spiral, and the table is adjusted vertically to bring the work centers in line with the center of the cutter.

**Safety on the Milling Machine.** When you have reached this part of the text, you should have become acquainted with the major parts of the milling machine, their names and their functions. The intelligent milling-machine operator will study and observe the following safe-working practices when operating the machine:

1. Learn how to operate the controls before using the machine.
2. Fasten the work *securely* in the vise or to the table.
3. Do not change spindle speeds of any machine while the machine is running (unless there is a device on the machine that can change spindle speeds while the machine is running).
4. Be sure to keep your fingers clear of the arbor bearing when setting the support arm in position.
5. Make sure that the cutter is clear of the work.
6. *Never* remove or tighten a milling-machine arbor nut with the power *on*. This *must* be done with the power *off*.
7. The support arm must always be in position when the arbor nut is being removed or tightened.
8. Keep hands and arms away from revolving cutters. *Never* reach over a revolving arbor to make an adjustment.
9. Do not check work or measure work while the cutter is revolving. Shut the machine off *first*.
10. Do not remove the guards from the machine.
11. Stop the machine and use a suitable brush to clean chips from the cutter (or cutters) or vise. Rags or waste must not be used near rotating cutters.
12. Do not lift heavy machine attachments alone. The same applies to heavy pieces of work. Ask someone to help you, or use a crane.
13. Do not walk away from the machine while the cutter is revolving. Shut off the motor.
14. *Never* permit another person to start or stop the machine for you. *Do it yourself*.
15. When removing end mills and face milling cutters, always hold a rag over the sharp edges of the cutting teeth. This will prevent painful cuts.
16. Keep the floor around your machine clean and free from objects that might cause someone to trip and fall.

17. Wear snugly fitting clothing. Loose garments, flapping ties, or long sleeves are easily caught in moving machinery.

18. Release all automatic feeds when you have finished using the machine.

19. Keep your mind on the job.

20. Do not lean on the machine. Keep both feet on the floor.

21. If you are not sure of the correct and safe methods of procedure, *ask your instructor.*

22. *Remember, "A moment's thought may prevent hours of pain"; you have eight fingers and two thumbs. Keep them.*

### QUESTIONS ON THE MILLING MACHINE

1. What is a milling machine?
2. How does it differ from a lathe?
3. Differentiate between factory-production milling and toolroom milling?
4. Name five important things a milling-machine operator must know in order to operate the machine intelligently.
5. Name two different types of milling machines. How do they differ?
6. Why should the spindle hole be clean? Why should it be wiped dry?
7. Name and explain the three different table feeds.
8. How many spindle speeds has the Brown & Sharpe universal milling machine? How are they obtained?
9. What is the function of the trip dogs?
10. What is the function of the table stops?
11. What is the normal direction of rotation of the spindle? Why?
12. How is the reverse direction of the spindle obtained?
13. Is the feed in this milling machine independent of the spindle speed?
14. Is there a power vertical feed? Is there a power crossfeed?
15. Name some attachments used in the milling machine.
16. Give the function or use of these attachments.
17. What kind of jobs can be done on a vertical milling machine?
18. Can these same jobs be done on a universal milling machine?
19. State 10 safety rules to follow when working on a milling machine.

### JIG BORER

The purpose of the jig borer (Fig. 5-30) is to locate accurately and to make the numerous holes so necessary for dies, jigs, fixtures, gages, and many other precision parts. The job of accurately locating

holes in parts has always been a very difficult and tedious job for the machinist and the toolmaker. They face this problem almost daily in their work and practically every toolmaking job today requires accurately located holes.

Although the single-point boring bar is the most important tool used, drills, reamers, and counterbores are also used. It can readily be seen that the operations of drilling, boring, reaming, and counterboring are done on the jig borer.

A jig borer has the essential elements of a vertical-spindle milling machine, but it is built lower to the floor and is of much more rigid and accurate construction. The machine must be rugged and sensitive at the same time—rugged for the heavy cuts and sensitive for the light cuts. It must have a wide range of speeds to allow boring the wide variety of holes which it is called upon to machine. Usual speeds are 40 to 1,500 r.p.m.

Various types of boring heads, chucks, and collets can be quickly fastened to the machine spindle for holding the many tools used with the machine.

A dial indicator with a grasshopper leg (bent) enables surfaces to be indicated or "picked up" so that the table can be moved a certain distance relative to that surface, to locate a hole. It is also used to align a workpiece edge with the travel of the table in either direction.

**Parts of the Jig Borer** (Fig. 5-31). This illustration shows the location of the important parts of the Moore No. 1 jig borer and every operator of this machine (or a similar machine) is urged to

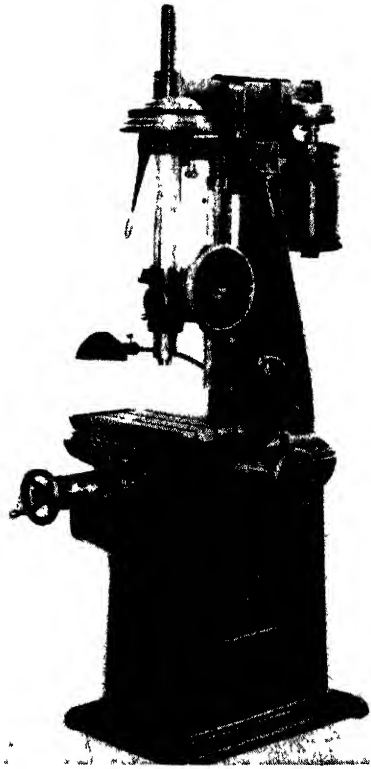


Fig. 5-30. The Moore No. 1 jig borer. (*The Moore Special Tool Company*)

know these locations and the functions of all the parts. However, since there are other jig borers on the market (jig borers manufactured by manufacturers other than the Moore Special Tool Company), the location of the various parts will vary accordingly.

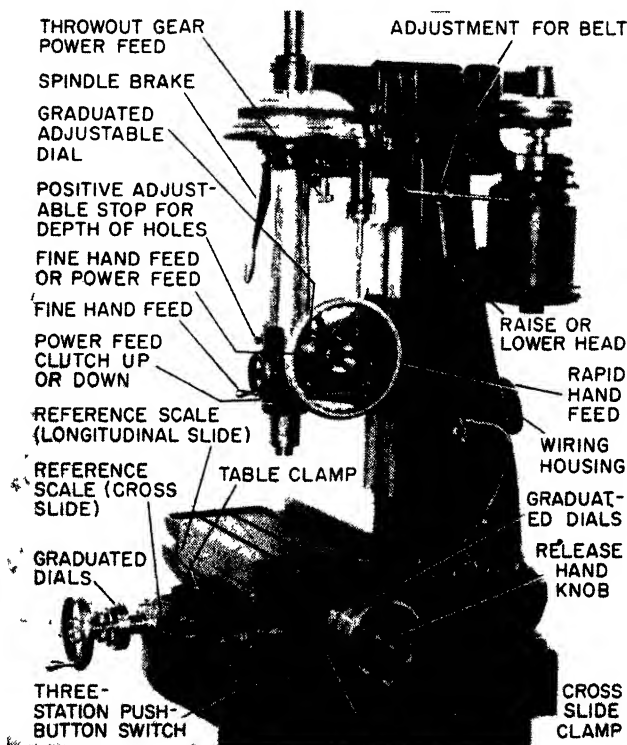


Fig. 5-31. Operating parts of the jig borer. (The Moore Special Tool Company)

The functions of the parts of the Moore jig borer follow:

*Throuout-gear Power Feed.* Pulling this knob downward engages the power-feed gears; pushing it upward disengages the power-feed gears. *Always stop the machine before engaging these gears.*

*Spindle Brake.* Used to stop the rotation of the spindle, this brake is manually operated and acts like an automobile hand brake.

*Graduated Adjustable Dial.* The dial is graduated in thousandths of an inch and can be adjusted to any reading.

*Positive Adjustable Stop for Depth of Hole.* This is a stop used to set a predetermined depth of hole to be drilled, bored, etc.

*Fine Hand Feed.* This is used for the fine feeding of the tool manually.

*Power-feed Clutch (up or down).* When the gears are engaged and the machine is started, the power-feed drive shaft rotates. This delivers power to the reversible clutches controlled by the power-feed clutch, and this will raise or lower the spindle, depending upon how the handle is used. Moving the clutch handle *up*, will raise the spindle; moving it *down*, will lower the spindle.

*Reference Scale (cross slide).* The scale is used as a reference point in moving the table perpendicular to the column; it determines the position of the starting point, or reference point, of the job.

*Reference Scale (longitudinal slide).* This scale is used as a reference point for the longitudinal movement of the table.

*Graduated Dials.* These are graduated dials in thousandths of an inch, used to measure the movement of the table when it moves away from and toward the operator.

*Three-station Push-button Switch.* This switch, used to rotate the spindle for three speeds—slow, fast, and stop—has a built-in transformer to supply 110 volts to the light and to switch and regulate the speed of the spindle.

*Table Clamp.* Used to clamp table to the cross slide.

*Cross-slide Clamp.* This is a clamp used to fasten the cross slide to the base of the machine.

*Release Hand Knob.* The knob is used to release the automatic feed of the table moving in a horizontal position.

*Graduated Dials.* These dials, graduated in thousandths of an inch, are used with the horizontal feed of the table.

*Wiring Housing.* This housing is a cover used to protect the electrical wiring of the machine.

*Fine Hand Feed or Power Feed.* This is used to engage the fine feed by hand or by power.

*Rapid Hand Feed.* This is a wheel used for larger feeds than those for fine feeds.

*Handle for Lowering or Raising the Head.* This handle is used only for lowering or raising the head.

*Belt Adjustment.* This is used to adjust the tension of the belt between pulleys.

**Inserting Shanks in the Spindle of the Machine.** Extreme care must be taken to be sure that the taper shanks on all tools inserted into the spindle are perfectly clean. Do not insert the shanks too tightly, especially when the spindle is warm. If the spindle is warmer than the inserted shank, the latter will subsequently expand and jam in the spindle.

Great care should be taken to protect shanks from finger perspiration, especially if the shanks are to remain in the spindle for any length of time. This might cause the shank and the spindle to rust slightly, making removal of the shank almost impossible.

When removing tools from the spindle, hold the brake firmly with the left hand and loosen the tool with the wrench in the right hand. While loosening the tool, make sure that the wrench does not slip out of the hand or off the hex on the shank. This might damage the table of the machine.

**Setting up the Work.** By means of the bolts and straps, clamp the work to the table of the machine securely and firmly enough to prevent it from moving its position while holes are being drilled or bored. Place the work to be bored on parallels, making sure there is sufficient space under the work to allow drills and boring tools to go through without hitting the table. In clamping, try to keep the bolts as close as possible to the work and to keep the ends of the straps directly over the points where the work rests on the parallels.

Either of two methods can be used to set work parallel with the direction of table travel. The first is simply to indicate one side of the job. The other is to place one side of the job against the straight-edge on the front or back of the table. In order to keep the work somewhere near the center of the table, it may be necessary not to have the job directly against the straightedge. In this case, feelers, size blocks, or parallels can be used, to make sure that the sides of the work are parallel to the straightedge.

**Making Settings.** With the Moore jig borer, the lead screws are used to make all longitudinal and transverse settings of the table. When making settings, therefore, always turn the handwheel in the direction of the arrow, thereby eliminating any error from backlash. If it is necessary to work backward, go past the setting farther than what corresponds to the backlash, then when making the final setting, turn to the right again, in the direction of the arrow.

**Locating the Position of Work on the Table with Respect to the Table.** There are various methods which may be used for locating or "picking up" work with respect to the spindle. Most of them involve the use of the small tools in the indicator set, which consists of an indicator with its holder, an edge finder, and a line finder.

The indicator is made so that it will work in both directions when it is used in conjunction with the holder. The point of the indicator is small enough to be used in holes about  $\frac{3}{16}$  in. in diameter. It can also be extended from the spindle far enough to pick up holes or bosses as large as  $7\frac{1}{2}$  in. in diameter.

If it is desired to locate the spindle centrally with the work, the point of the indicator can be swung back and forth, moving the table with the screw until the indicator reads the same on both sides.

*NOTE:* In setting the point of the indicator, care should be taken in swinging the point of the indicator that it be in the proper relation to the offset on the indicator holder.

Now loosen the dial clamp on the screw. Then set the dial to zero and clamp it firmly. Set the scale on some even inch. The position thus established should be checked by turning the screw to the left about 0.005 in. to 0.010 in. to be sure the back lash is taken up. Then, returning to the original zero position, swing the indicator both sides as before.

The edge finder may be used to set the center of the spindle over the edge of the work. This tool is ground so that the working face is exactly 0.200 in. from each side of the slot on the top. Hold the working face against the edge of the work to be located and indicate the slot so that the indicator reads the same on both sides. This position may be checked in the following manner: Back away 0.200 in. and touch the indicator to the actual face of the work. In this position, the indicator should read exactly the same as it did originally on both sides of the slot of the edge finder.

Occasionally, it will be found desirable to lay out lines on the work before setting it up in the machine. In order to pick up the location of these lines, use the wiggler or line finder. This is not so accurate as the indicator, but it is more convenient in some cases.



**Coordinates.** The method found to be most efficient in locating holes for jig-boring operations is the *coordinate* method. There are two systems of coordinates used to locate points on workpieces used in machine-shop practice, namely, the *rectangular* and the *polar*. The rectangular system is used where a point is to be located from two reference lines, or axes, usually called the  $X$  and  $Y$ . This system is used in the making of graphs. In the polar system, a point is located from a zero, or reference line, by an angle measurement as well as by a rectangular distance.

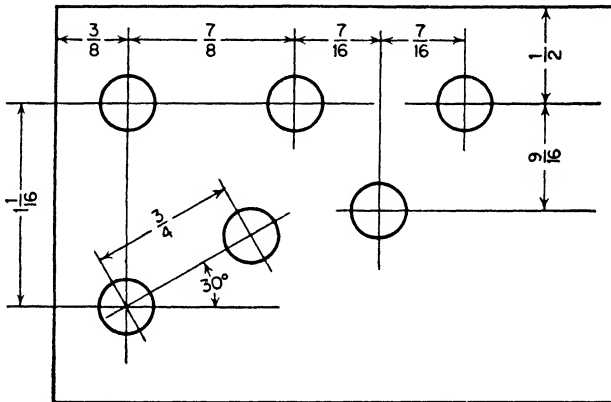


Fig. 5-32. The conventional method of locating holes

By means of two precision lead screws, working at right angles to each other, the workpiece can be moved into any desired position in relation to the fixed spindle. Any point on the workpiece may be used as a reference, or starting point, such as a hole, a dowel, the intersection of any two edges or lines, etc.

Having established this point in relation to the spindle by means of an indicator, edge finder, or line finder, lock the table, and the graduated dials are set and locked at zero. The scales may then be set to the nearest full-inch graduation and these figures noted, as they now become the actual starting point for all dimensions.

Assuming, for example, that the setting comes to 4.000 on the cross scale and 6.000 on the longitudinal scale for the typical conventionally dimensioned piece (Fig. 5-32), it should only be necessary to make a simple sketch (Fig. 5-33), adding the dimensions to the

previously established reference figures; *i.e.*, 4.000 and 6.000, in order to determine coordinates corresponding directly to readings shown by the scales and dials. The position of any hole may be set very quickly, enabling the operator to move from one hole to another, between operations. Hence, it is not necessary to finish one hole before proceeding to the next.

Study Figs. 5-32 and 5-33 and you will note that the very first hole on top of the piece is exactly  $\frac{3}{8}$  in. from the top left edge, when the

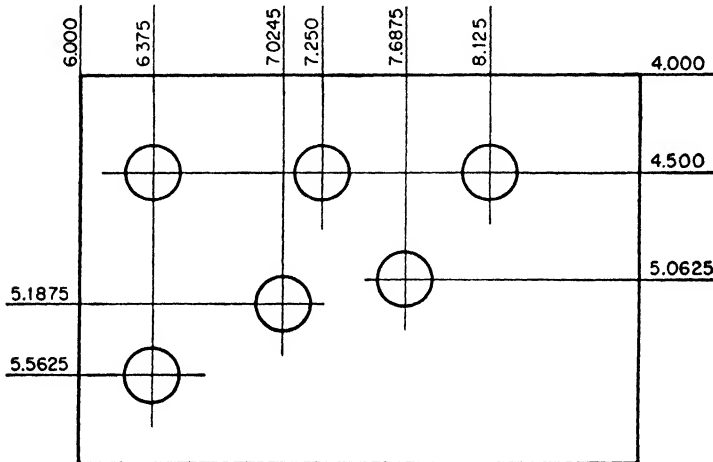


Fig. 5-33. The method used for locating holes for jig-boring operations.

reading becomes 6.375 in. instead of the  $\frac{3}{8}$  in. in Fig. 5-32, only because we added 6.000 (the starting point on the longitudinal scale) to the  $\frac{3}{8}$  in. indicated on the drawing in Fig. 5-32. All the other holes are in the same relative locations.

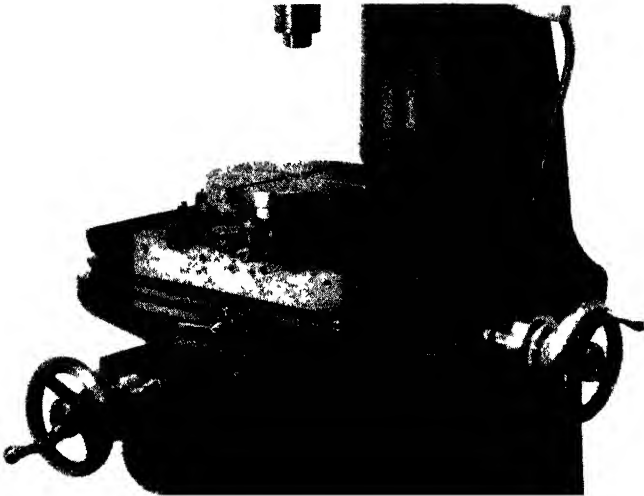
**Suggested Order of Operations.** The Moore Special Tool Company suggests the following order of operations in the use of their jig borer:

1. Spot-drill all holes on the workpiece.
2. Drill and bore all holes to the roughing dimensions.
3. Go back and check the original setting of the work to make sure that it has not shifted during the roughing operation.
4. Make the final finish-boring cuts in each hole.

**DRILLING AND BORING**

1. First spot the holes with a center drill held in the collet or chuck.
2. Drill a small hole, which is gradually enlarged by successively larger drills, increasing the diameter about  $\frac{1}{4}$  in. with each step. Carry this operation to within 0.005 or 0.010 in. of the final size.
3. Finish bore with a single-point tool.

The eccentric boring chuck furnished with the machine for finish-boring is of the swivel-block type. Therefore, the graduations have a



**Fig. 5-34.** The rotary table used with the jig borer. (*The Moore Special Tool Company*)

meaning only in connection with the length of tool used. When the tool bits furnished with the machine are used, each graduation represents 0.001 in.

Turning the adjusting screw to the right increases the size of the hole to be bored. Always loosen the swivel-block clamp screw before setting, and always clamp firmly before making the cut.

In making the final-boring cut, first set the tool accurately for the undersized hole and then advance the tool slightly. After this make a test cut and measure the hole size very accurately. This measurement, together with the graduations on the chuck, will then enable

the operator to set the tool accurately for the final cut. Always remember to tighten the swivel screw firmly before making the final cut.

**Rotary Table.** In locating holes to be bored on bolt circles, the *rotary table* (Fig. 5-34) will be found very handy. Angular measurements may be taken from the graduations and vernier on the edge of the table and radial measurements from the lead screws of the

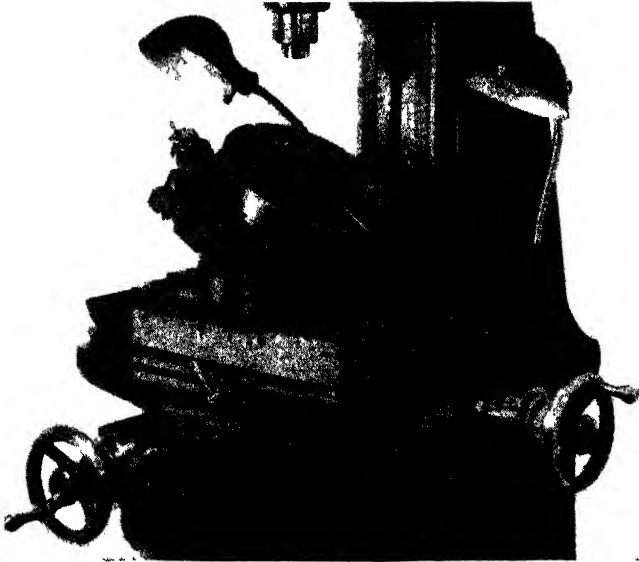


Fig. 5-35. The rotary table being used with a sine table. (*The Moore Special Tool Company*)

machine. The coordinate system of measurements cannot be used here, but a system of *polar* coordinates is used. Figure 5-35 shows a rotary table being used with the *sine* table. This sine table is used like the sine bar, where the height of the table is calculated by trigonometry and the height is set with gage blocks.

### JIG GRINDER

The jig grinder (Fig. 5-36) has the essential features of the jig borer and performs similar operations on the same work, but it uses

a grinding wheel or a diamond-charged mandrel on a hardened workpiece.

The jig grinder operates at much higher speeds than the jig borer, up to 50,000 r.p.m. It has a built-in taper adjustment for grinding

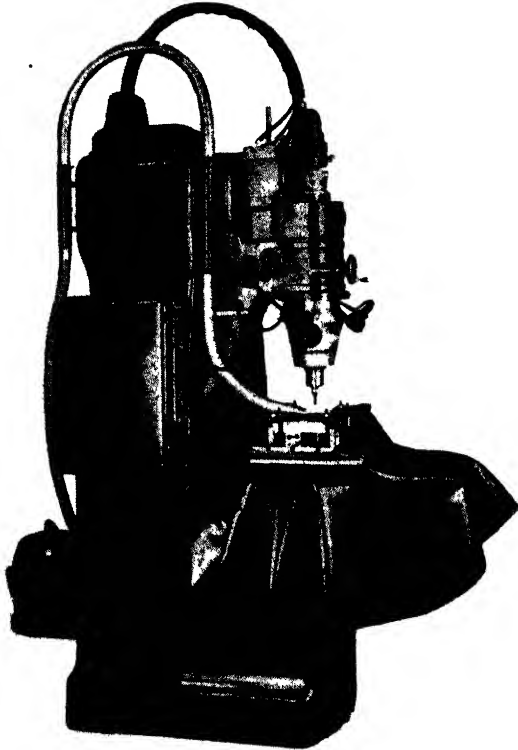


Fig. 5-36. The Moore jig grinder. (*The Moore Special Tool Company*)

slightly tapered holes. It also has a depth-measuring gage and depth control, like the jig borer.

### QUESTIONS ON THE JIG BORER

1. What is the chief function of the jig borer?
2. Why is the jig borer very similar to a vertical milling machine?
3. What operations can be performed on the jig borer?

4. Why is the jig borer able to locate holes accurately?
5. What is the function of the two accurate lead screws?
6. What precaution must be taken when inserting shanks into the spindle?
7. Tell how you would accurately locate the position of a job with respect to the table?
8. How is the indicator used on this machine different than the ordinary indicator?
9. Figure 5-37 shows a conventional sketch of a job in which holes are to be drilled and bored. Draw a sketch showing the same holes located using the coordinate method. Use 3.000 and 4.000 as starting points.

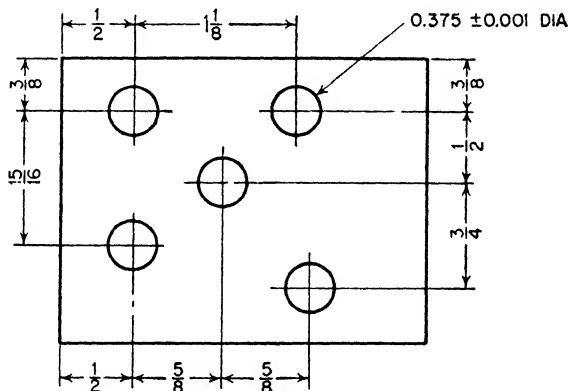


Fig. 5-37.

10. What is the suggested order of operations to be used in jig boring?
11. Of what use is the rotary table? Give examples.
12. Of what use is the sine table? Give an example.

## Milling Cutters and Their Holding Tools

Every machine tool has its complement of cutting tools, but, compared to milling cutters, the other cutting tools are few in number, simple in form, easy to sharpen, and inexpensive to buy. Do not think, however, that it is difficult to learn about milling cutters; the point is that it is an especially interesting and important subject.

One reason the milling machine is so valuable in toolmaking and in manufacturing, and so interesting to most machinists, is that there is an almost unlimited variety of jobs to be milled and, of course, the variety of work that may be done is dependent to a certain extent upon the variety of cutters. Also, it is true that the quantity and quality of milled work is particularly dependent upon the shape, size, kind, and condition of the cutting tool and the way it is held.

The purpose of this chapter is to give the student, at the beginning of his milling-machine experience, an idea of the variety of cutters, of the ways in which different cutters are held, and—to as great a degree as may be—an appreciation of what it means to select and set up, to use and care for properly the milling cutter best suited for the job at hand.

**Milling Cutters and Milling.** Efficient and economical milling operations are dependent on a number of factors, each one being more or less dependent on the others. These factors are:

1. The milling machine.
2. The milling cutter.
3. The size and shape of the piece to be milled.
4. The fixture or other methods of holding the work.
5. The finish desired.
6. The feed and speed of the milling cutter.

*Milling Machine.* The milling machine must be of rugged construction so as to be able to absorb both the forces and shock incident to the cutting of the material. Further, it must be maintained in good repair. Bearings, gibs, feed screws and nuts, clamps, and other operating parts should receive periodic inspection and necessary repairs.

*High-speed Milling Cutters.* The value of a milling cutter is determined by the rate at which it can produce, by the accuracy with which it can duplicate a required part, and by the number of pieces it can produce per sharpening. To be able to fulfill one or all of these outstanding requirements, a cutter must be made correctly, it must be dependable, and it must be long-lived.

Cutters must be designed to fit the job at hand. Coarse-tooth cutters are suitable for taking heavy cuts because they have ample chip space and ruggedness for just such heavy duty. For lighter cuts, fine-tooth cutters are better because more teeth will be in contact with the work and, therefore, a better finish will be produced. Rake angles also have a marked effect on the cutting action of cutters. In general, soft and ductile materials can be cut more easily with large rake angles (10 to 20 deg.) and hard and brittle materials are cut best with smaller rake angles (0 to 10 deg.). However, excluding special or "freak" cases, the best average rake angle for milling cutters lies between 10 and 15 deg., with a preference for  $12\frac{1}{2}$  deg., which has proved suitable for all-round work.

*Size and Shape of the Piece to Be Milled.* The nature of the piece to be milled has a bearing on the type of cutter to be used as well as on the permissible feeds and speeds. If the piece is thin, it will not withstand the strains of a heavy cut. Consequently, the feed must be reduced to a point where no vibration or breakage of the work will occur. When cutters with large spiral or helix angles are used, a smooth shearing cut is produced which eliminates "hogging in," allowing feeds to be greater than with cutters that have small spiral angles or straight gashes.

*Proper Design of Holding Fixtures.* The proper design of holding fixtures will, in many cases, permit much greater production than is possible if this detail is neglected. The fixture must support both itself and the work in such a manner that vibration is reduced to a minimum. This is even more important for climb cutting (Fig. 6-1a,



below) than for conventional cutting. The penalties for neglecting this factor are poor finish, inaccuracy, and chatter.

*Finish Desired.* It is obvious that if a very smooth finish is desired, the feed must be cut down to a point where tooth marks or revolution marks will not be visible. Here the condition of the milling machine and the support of the work and of the cutter arbor all have an important bearing on the finish and on cutter life.

*Feeds and Speeds.* Feeds and speeds cannot be prescribed, except in a very general way. Practically every job differs in some way from any other as to size of cut, condition of machine, etc. A close study

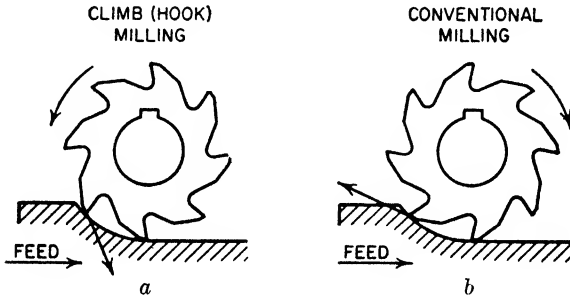


Fig. 6-1. Two methods of modern milling: (a) climb; (b) conventional. (*The Brown & Sharpe Manufacturing Company*)

of the job will in most cases give the experienced operator an idea of the proper feeds and speeds.

**Classification of Milling Methods.** There are two distinct methods of milling, classified as follows: *conventional* or *up-milling* and *climb* or *down-milling*.

Climb milling (Fig. 6-1a) differs from conventional milling (Fig. 6-1b) in that the work is fed in the same direction as the movement of the cutter teeth, rather than against the movement of the teeth.

In climb, or down-milling, the cutter has a tendency to spring *away* from the work and, at the same time, *push* the work *down* against its supporting surface. The chip thickness decreases uniformly, from a maximum at the top (beginning) of the cut to zero at the bottom (end) of the cut.

Conventional, or up-milling, makes use of the forces created to

13. If paper shims are used, check the four points once more, to make sure.

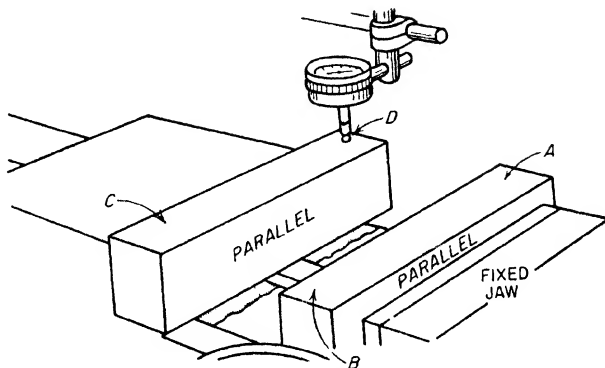


Fig. 2-32.

*To Test the Solid Jaw of the Vise.* If the face of either of the jaws of the vise is dented and scored, it should be repaired. If the solid jaw is not square with the seat, it is impossible to clamp the work against the jaw and to machine it square. To test for squareness takes only a few minutes. Follow this procedure:

1. Clamp the beam of a precision square against the solid jaw (with a piece of wood between the movable jaw and the square), as shown in Fig. 2-33.
2. Arrange the indicator and move the worktable the distance *A* to *B*.
3. If the indicator registers the same at both ends of the blade, the jaw is square. It will be best to try the jaw near each end and in the middle.
4. If necessary, shim the jaw until it is square.

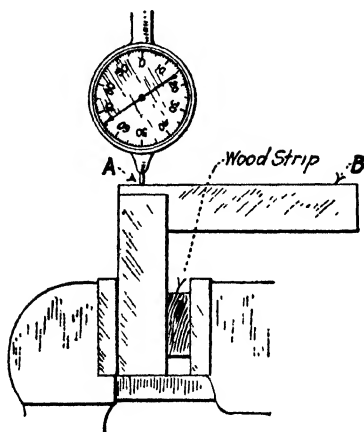


Fig. 2-33. Testing the solid jaw of a vise for squareness.

*To Set the Vise Parallel with Direction of Stroke.* While the graduations on the swivel plate are accurate enough for nearly all purposes, occasionally a cut, for example, a shoulder, must be made exactly parallel with the edge located against the jaw or the work may be spoiled. To test for this position is very simple. Arrange the length of stroke to about the length of the jaw, hold the indicator in the tool post and slowly run the shaper by hand to note if the indicator registers the same at both ends of the jaw. If necessary to make adjustment, clamp the vise lightly and tap with a babbitt hammer until the setting is correct, then clamp tight and test once more.

*To Set the Vise Square with Direction of Stroke.* To test and, if necessary, to correct the setting, the indicator is arranged as before, but, the vise being turned around 90 deg., the *worktable* instead of the *ram* is moved by hand to show the movement, if any, of the indicator needle.

*NOTE:* An angle plate or similar holding device when clamped to the worktable may be tested for square or may be set square or parallel with the direction of the stroke in exactly the same way as the vise.

**Chips and Burrs as a Cause of Inaccurate Work.** One of the most frequent causes of damaged or spoiled work is failure on the part of the operator before clamping the work to remove the burrs and clean the chips from the work and also from the holding device, whatever it is—vise, fixture, chuck, or clamp of any description.

*Chips.* Steel chips are worse than cast-iron chips, but if either are pinched between a finished surface of the work and the vise jaw, both the work and the jaw will be damaged, and possibly the work will be thrown out of true enough to ruin it. If chips are allowed to get under the parallels, or between the parallels and the work, it is obvious that the work will not seat properly and the finished surface cannot be accurate.

*Burrs.* Particularly on steel and wrought metal, the last few strokes tend to roll the metal over the corner, forming a burr. This burr is more or less difficult to remove, depending a great deal on the sharpness of the shaper tool. If the surface *x*, Fig. 2-34, over which the burr is rolled, is the next surface to be machined, it will cause no trouble, but if surface *x* is to be used as a seat for finishing the opposite side, or if *y* is to be used as a seat, the burr must be removed.

Burrs can be largely eliminated by cutting down the cross feed to a minimum on the last few strokes. Sometimes the heavier burrs are removed with a special burring chisel similar to a wood chisel; the lighter burrs are easily removed with a fairly fine file. In either case, be very careful not to spoil the corner.

Then there is another kind of burr, the kind thrown up by making a nick or dent in a piece of metal. For example, pinching a rough forging or casting between the soft vise jaws without using protecting pieces will dent the jaws and throw up burrs; likewise, pinching a chip between the vise jaw and the finished surface.

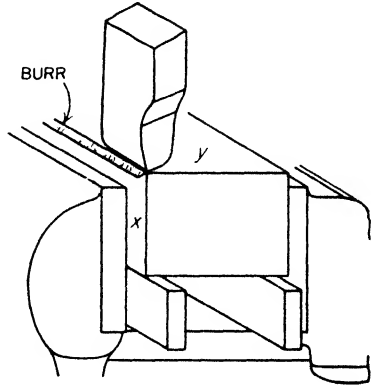


Fig. 2-34.

Dropping a parallel so that it strikes the machine may nick it and throw up a burr, and hammering a rough piece down on the parallel will do the same.

It is certain that if the work itself, the holding device, and the parallels are not clean and otherwise in good condition, at least two evils will result: (1) the work will be inaccurate, damaged, and possibly spoiled, (2) the parallels, vise, etc., will be damaged.

#### PRELIMINARY HINTS ON SHAPER WORK

1. Keep the machine clean and well oiled.
2. Use the proper wrench or handle and, when they are not in use, keep them where they belong.
3. A vise jaw that is scored and dented and out of true is a disgrace in any shop. A real mechanic is careful. Use brass or copper or cardboard to protect the jaws when clamping the rough surfaces of bar stock, castings, or forgings.
4. Parallels should be kept clean, free from burrs, straight, parallel, and square. Examine them before using and be sure they are at least clean and free from burrs. Do not hammer a rough piece down on a parallel.

5. Be sure there are no chips on the seating surfaces, or the clamping surfaces of the vise, parallels, and work.
6. Carefully remove the burr caused by any previous cut if it will interfere with the proper seating or clamping of the work.
7. Select the proper tool, grind it carefully and oilstone it. A workman is often judged by the tools he uses.
8. To seat the work use a babbitt hammer or babbitt ball. Do *not* use a wrench.
9. Do not hammer the work with the babbitt, tap it just hard enough to seat it. Do not tighten the vise again after seating the work, as this is likely to lift the work a trifle.
10. Tissue paper "feelers" between the parallels and the work are often very useful to determine if the work is properly seated.
11. Do not pinch a thin piece of work too tight or it will buckle more or less and be out of true when the pressure is released.
12. Be sure the top of the table and the bottom of the vise plate are clean and also free from burrs before resetting a vise that has been removed from the worktable.
13. When setting the tool to a surface already finished (or to a size block), be sure the tool block is firmly seated, place a piece of tissue paper under the cutting edge, and then feed the tool down to pinch the paper lightly.
14. When setting up irregular work, be sure the head and also the bottom of the ram will clear the work during the whole length of stroke and the whole width of the cut.
15. Be sure, at all times, that the tool block works freely and seats properly. Failure to do this has caused a lot of spoiled work.
16. Do not hammer the side of the apron to swivel it. If the edge of the seating surface of the apron is dented and burred it will cause the tool block to bind in the box.
17. Maintain taper gibs, pins, and other take-up devices.

**Length of the Stroke.** The stroke of the shaper ram is dependent upon the length of work that is to be machined. On mass-production jobs, once the length of the stroke is set, it is not changed until that particular job is completed. But in the school shop, the length of the stroke is usually changed with each different job, which usually entails the machining of very few pieces. The apprentice should

clamping (Fig. 2-23), the clamp is *not* directly above the work and the bolt is *not* in the middle of the setup. Clamping pressure must be evenly distributed over the work and block when clamped if it is to hold properly.

The description and use of some of the common clamps used in machine-shop work follows.

*Clamps*, or *straps*, as they are sometimes called, are designed to hold workpieces in place when they are being machined. These clamps are of various designs and shapes but all have the same function—to hold work in place.

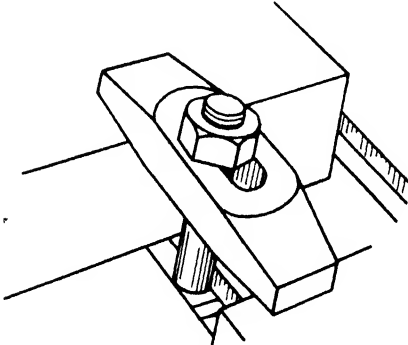


Fig. 2-24. The plain clamp.

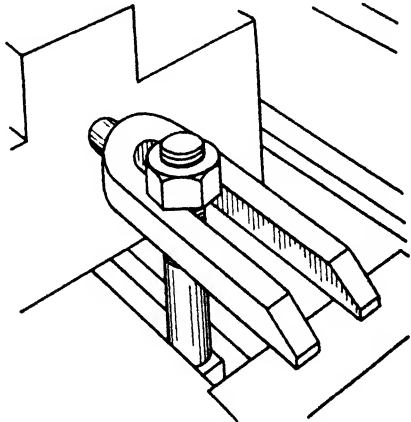


Fig. 2-25. The U clamp.

Some of the more common types of clamps and their uses are described here.

The *plain clamp* or *strap* (Fig. 2-24), which is strong, is used for general clamping purposes. It has an elongated slot through which the T bolt passes. The shape of the workpiece to be clamped must be such that the clamps will not interfere with the machining operation when the clamps are used.

The *U clamp* (Fig. 2-25), another type, is especially useful when the nut on the T bolt does not have to be removed. This is an advantage, in that the bolt may be set in the best position for clamping without having the nut removed from the bolt, and then the clamp is placed under the nut. Care must be taken not to exert great

pressure on this type of clamp, because it has a tendency to spread and bend under such conditions.

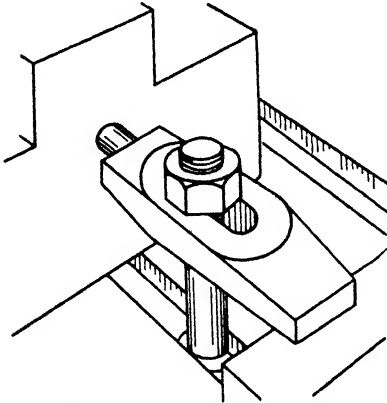


Fig. 2-26. The finger clamp.

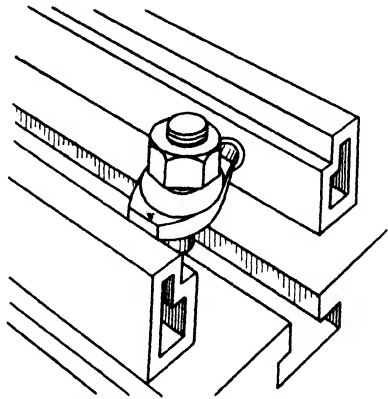


Fig. 2-27. The double-finger clamp.

The *finger clamp* (Fig. 2-26) is used where a cored or drilled hole is available as a support for the finger. This is a convenient way in which work may be clamped without interfering with the shaping operation.

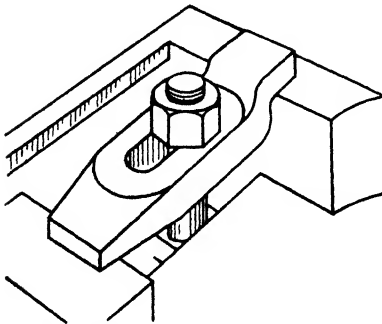


Fig. 2-28. The gooseneck clamp.

The *double-finger clamp* is similar to the single-finger clamp and is used in the same way. In this clamp two fingers may be inserted in the holes for support (Fig. 2-27).

The *gooseneck clamp* (Fig. 2-28), sometimes called an *offset clamp*, has the advantage of being below the surface that is being machined, when used in clamping.

The *C clamp* (Fig. 2-29), which is used, as a rule, when other clamps and bolts cannot conveniently be employed, gets its name from the fact that it is shaped like the letter "C." The parts to be held together are clamped between the pad and the end of the screw. When pressure is applied by turning the screw, the pieces are held

together. These clamps come in many sizes, the smaller ones designed for light work and the heavier ones for heavy-duty work.

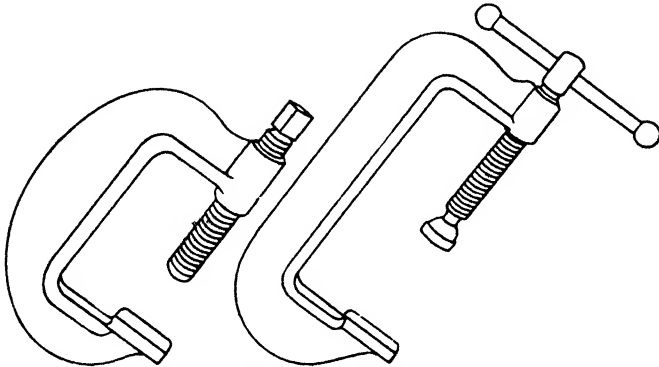


Fig. 2-29. C clamps.

### CAUSES OF INACCURATE WORK

**Inaccuracy in Vise or in Vise Setting.** In most shops it may be assumed that the shaper vise, as it is arranged, is right enough for the average job, but it may happen to be necessary to machine a piece which must be especially accurate—square and to an exact size—in which case it will probably be advisable to test the bottom of the vise (on which the work rests) for parallelism, and also to test the solid jaw, to make sure that it is square.

#### **HOW TO TEST THE WORK SEAT**

1. Open the vise wide and set the vise jaws approximately parallel with the direction of the stroke.
2. Be sure that the bottom of the vise is clean and smooth. This is important.
3. Select two parallels high enough to project above the top of the vise jaws and long enough to extend about an inch or two beyond the width of the vise. Be sure that the parallels are clean and smooth.
4. Set these parallels as shown in Fig. 2-30, one against each of the vise jaws.



5. Select an indicator (one with a dial face preferred) and make sure that the pointer on the dial does not stick.

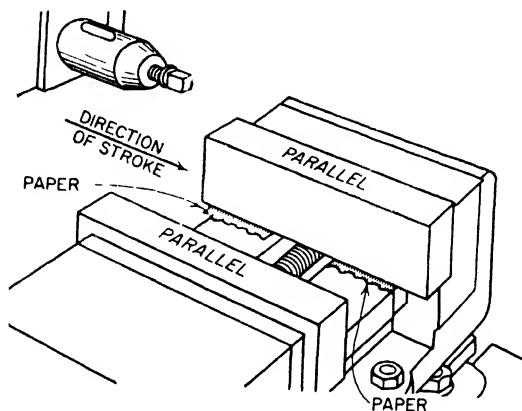


Fig. 2-30.

6. Arrange the indicator as shown in Fig. 2-31.

7. Bring the indicator contact point down to the parallel, using the feed handle of the machine; bring it down slowly until there is contact with the parallel.

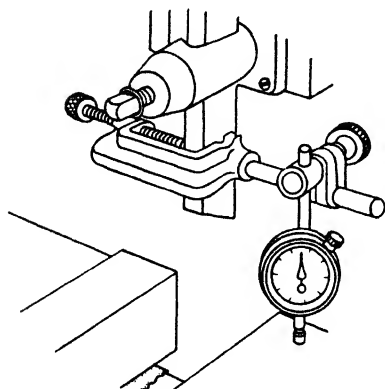


Fig. 2-31.

8. Give the feed handle a *slight* turn so as to get a reading on the indicator (about 0.010 in.)
9. Adjust the dial so that the zero mark of the dial is set at this reading.
10. Get readings at points A, B, C, and D (Fig. 2-32).
11. If the readings at all four places are the same (zero), the work seat is parallel.
12. If the readings are not the same, adjust by using paper shims between the worktable and the vise.

*lift* the work *into* the cutter and spring the cutter *down* into the work. The thickness of the chip increases uniformly at the top (end) of the cut.

“Climb milling can be used advantageously on many kinds of work to increase the number of pieces per sharpening and to produce a better finish. Its employment permits increased production, as a milling operation can be performed at each end of the machine table permitting loading and unloading of one fixture while the cutters engage the work held in the other fixture. With climb milling, saws cut long thin slots more satisfactorily than with conventional milling. Also, work can be held more securely as the cutter itself tends to force the work into the clamping fixture and against the table, a feature especially desirable when milling thin flat pieces.

“Stock cutters can be used for both climb and conventional milling except when climb milling soft steel of low carbon content. For work of this class, special cutters made with a large amount of rake and a steep spiral angle are required to produce a good finish. When ordering, complete details of operations to be performed should be given including the analysis of the material and amount of stock to be removed. Climb milling is not recommended ordinarily for use on cast iron or forgings.

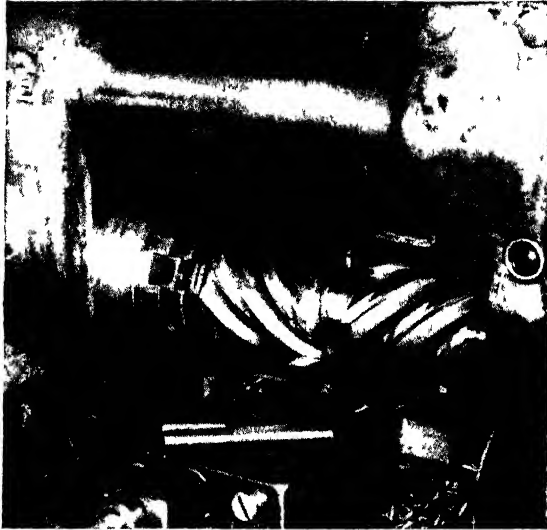
“Because of the tendency of the cutters to pull the work forward in climb milling, milling machines designed with special features adapting them for climb milling are essential to the success of this operation. Light climb milling cuts, however, may be taken on machines not designed for climb milling, provided means can be found to prevent the table from being pulled forward by the cutting action of the cutters.<sup>1</sup>”

**Common Milling Operations.** The milling machine is a very versatile machine and therefore many different kinds of operations can be performed on it. However, in this section, just a few of the more common milling operations will be explained. These are:

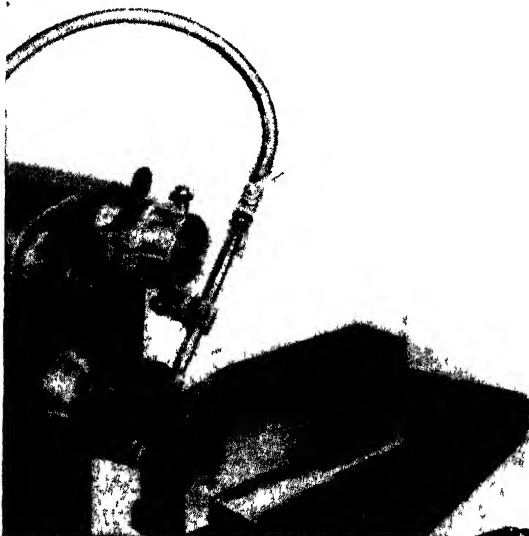
*Plain Milling or Slab Milling.* The production of a flat surface parallel to the axis of the cutter (Fig. 6-2).

*Face Milling.* The production of a flat surface at right angles to the axis of the cutter (Fig. 6-3).

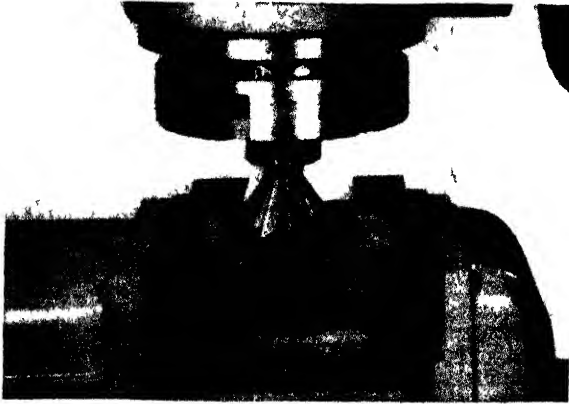
<sup>1</sup> Brown & Sharpe Manufacturing Company, Providence, R.I.



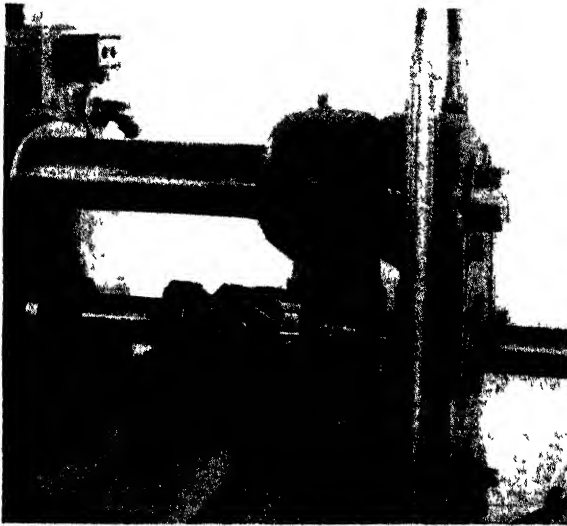
**Fig. 6-2.** Plain milling. Several pieces being milled at the same time (*The Brown & Sharpe Manufacturing Company*)



**Fig. 6-3.** Face-milling. (*The Brown & Sharpe Manufacturing Company*)



**Fig. 6-4.** Milling a dovetail using a single angle cutter (*The Cincinnati Milling Machine Company*)



**Fig. 6-5.** Form-milling using a gang of three interlocking cutters, (*The Brown & Sharpe Manufacturing Company*)



Fig. 6-6. Gang-milling operation using two side milling cutters, four heavy-duty plain milling cutters, and two staggered-tooth milling cutters on cast iron (*The Cincinnati Milling Machine Company*)

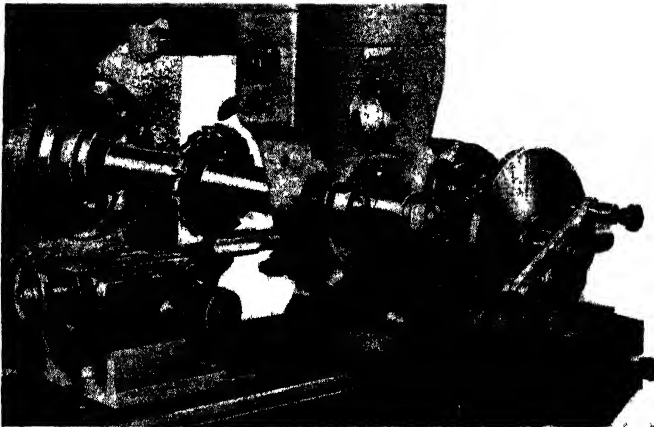
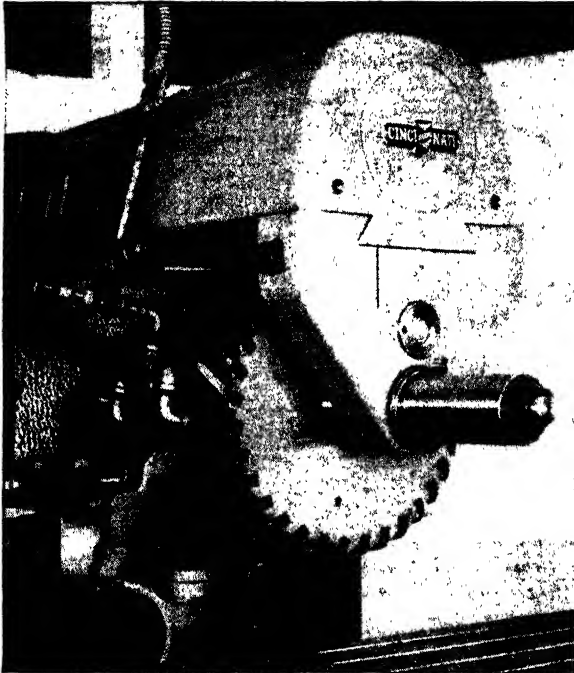


Fig. 6-7. Milling a four-flute tap using direct indexing. (*The Cincinnati Milling Machine Company*)

*Angular Milling.* The production of a flat surface at an inclination to the axis of the cutter (Fig. 6-4).

*Form Milling.* The production of a surface having an irregular outline (Fig. 6-5).

*Gang Milling.* Two or more cutters used together on one arbor (Fig. 6-6).



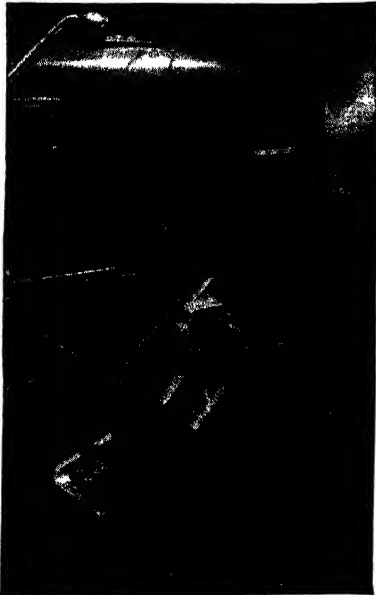
**Fig. 6-8.** Straddle-milling operation using two large-diameter inserted-tooth half-side-milling cutters. (*The Cincinnati Milling Machine Company*)

*Milling Flutes.* A term applied to the grooving or cutting of flutes on drills, reamers, taps (Fig. 6-7).

*Straddle Milling.* Term applied when two side-milling cutters are used and two sides of a piece are milled at the same time (Fig. 6-8).

Certain particular operations have their obvious names, such as *sawing* (Fig. 6-9), *grooving*, *slotting*, and *gear cutting*. *Profiling* is

milling to a predetermined outline by means of a guide bar and template. *Routing* is milling to a more or less irregular outline while guiding by hand.



**Fig. 6-9.** Mill sawing operation on aluminum, using an 8-in.-diameter metal-slitting saw, having side chip clearance and undercut sides. (*The Cincinnati Milling Machine Company*)

### MILLING CUTTERS

From the illustrations of the kinds of milling operations given in the previous paragraph, it will be apparent that a great variety of kinds and sizes of milling cutters are used. There are, in fact, more than 150 different kinds of cutters on the market, made in more than 4,000 different stock sizes, one company alone making more than 3,000 different stock sizes of cutters.

It is not enough to know that there are many kinds and sizes of cutters. The machinist should know the *names* of the cutters and, in a general way, the *sizes* that may be obtained. He should know the *uses* of the cutters. The same cutter may be used for a variety of operations and, on the other hand, any one of a number of kinds of cutters may be used to perform a given operation. In milling, as in other machine-shop work, the resourcefulness of the machinist is often taxed to perform the given operation. For example, the best cutter to use may not be available, but another kind of cutter may do almost as well, and the job can be finished without delay.

It is easy enough to become familiar with the names and sizes, but to get acquainted with *uses* of the various cutters will require more time and greater effort.

Learn to call for a cutter by the name and the size required. Do not be satisfied to use a cutter, the family name, given name, and

general characteristics of which you do not know. Get an idea of what the rest of the family, the big ones and the little ones, are like. For example, in a watch factory is used a slitting cutter 1 in. in diameter and  $\frac{1}{64}$  in. thick; in an armor-plate mill, a similar cutter is used that measures 6 ft. in diameter and is 2 in. thick. How many sizes of metal-slitting cutters are you able to find in your toolroom? How many sizes are given in a tool-cutter catalogue?

Learn the uses of the cutters by study, reasoning, asking questions, and observation. Learn to use your "head," your tongue, your ears, and your eyes. It will "pay off."

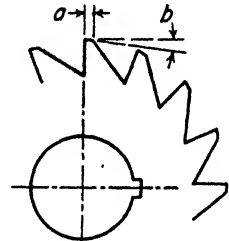
**Types of Milling-cutter Teeth.** Three distinct kinds of teeth are used in the manufacture of milling cutters: the *saw tooth*, the *formed tooth*, and the *inserted tooth*.

**Saw Tooth.** Until the last few years, the saw tooth (Fig. 6-10) was used almost universally for all kinds and shapes of milling cutters. It is the cheapest type of tooth to produce either in straight or in spiral form and is still in frequent use in end mills, metal-slitting cutters, and the smaller sizes of plain milling cutters. It will be observed that the cutting edge is given clearance by backing off the "land" about 5 deg. This is done in the cutter grinder when the cutter is sharpened.

The term *saw tooth* is not used today as standard practice. Teeth may be either form-relieved or profile-ground. In *form-relieved* milling cutters, the clearance angle is produced during manufacture in a relieving machine. These are usually sharpened on the *face* of the tooth, to preserve the clearance angle and the contour of the profile. In *profile-ground* cutters, the profile of the tooth is ground to the exact shape desired.

The cut (Fig. 6-10) shows a *radial* face of tooth. The tendency is to give the coarser tooth cutters about 10 deg. rake.

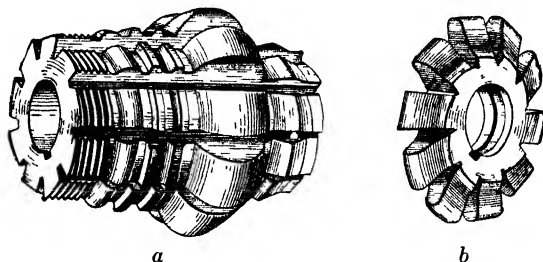
**Formed Tooth.** One of the chief values of the milling machine is the production of a large number of duplicate pieces having curved, shouldered, or other irregular surfaces. This kind of work can be done very much more quickly in the milling machine than in any



**Fig. 6-10.** This figure shows the clearance (b) on the land (a) of a saw tooth of milling cutter.



other machine, such as the shaper or the planer. Also, a very large number of pieces may be milled without changing the setting of the machine, thus making it possible to use more or less inexperienced workmen and still produce a fine and accurate grade of work. Owing to the fact that the so-called *saw tooth* of an irregular outline cannot be sharpened without changing the contour of the cutting edge, this tooth has been largely superseded, in the milling of irregular surfaces, by what is known as the *formed* tooth. For finishing certain irregular shapes to an exact outline, the use of the formed-tooth cutter (Fig. 6-11) in the milling machine is the most efficient method. A surface with an undercut cannot be finished in this way, but for

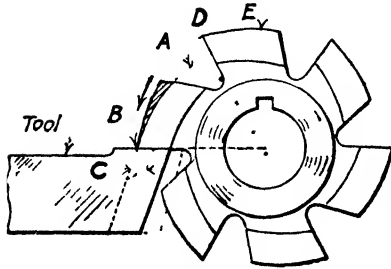


**Fig. 6-11.** Formed cutters. In (a) is shown a very special formed cutter, and in (b) a gear cutter.

most other irregular surfaces of a size not too large, and a quantity production that will warrant the cost of the cutter, this kind of cutter is advantageous. The formed cutter may be used, if desired, with other cutters to make up a gang (Fig. 6-6). The special advantage of the formed cutter lies in the fact that it may be sharpened many times without changing the shape of the cutting edge if, when sharpened, the *face of the tooth is ground radially*.

The formed cutter is made by leaving a land of considerable width between the grooves and then backing off or relieving this land eccentrically. This is accomplished in a special machine or in a lathe having a relieving attachment, by means of a forming tool of the correct shape. It is held so that its face is on a radial line with the cutter. This tool is so arranged in the machine or attachment as to automatically *feed in* to back off the land of each tooth and snap back through the tooth space, ready for the next tooth, as the cutter slowly revolves (Fig. 6-12).

*Inserted-tooth Cutter* (Fig. 6-13). Since the advent of high-speed steel, the inserted-tooth cutter has become very popular. Cutter



**Fig. 6-12.** Backing off a formed cutter. Note the eccentric curve of the land of the tooth, the tooth has been "backed off," or "relieved," or "given clearance" an amount equal to the shaded portion above B. As the cutter revolves and the point A approaches the point B, the tool moves "in," and when point A has reached point B, the tool has moved in an amount equal to C. Then the tool snaps back, ready to start at D its motion "in" to back off the next tooth E. A slow speed and a very fine feed (cross-feed) are necessary.

blades made of high-speed steel are inserted and rigidly held in a blank made of machine steel or cast iron. There are various methods of holding the blades employed by the different manufacturers. Inserted-tooth cutters are especially efficient for the reasons that they are economical in the first cost and that the worn-out or broken blades can be replaced by new blades. It is an especially desirable way of making large cutters.

**Kinds of Milling Cutters.** *Plain Milling Cutter.* The most common form of milling cutter is known as the plain milling cutter (Fig. 6-14), which is merely a cylinder having teeth cut upon its periphery for the purpose of producing a surface parallel to the axis of the cutter. When over  $\frac{3}{4}$  in. wide, the teeth are usually cut on a helix. The object of the helix tooth is to give a shearing cut. The shearing cut reduces the stress upon the tooth by preventing a distinct shock, which occurs in a cutter with straight teeth when each tooth starts to take its chip. The helix-tooth cutter produces a better and smoother finish, requires less



**Fig. 6-13.** Inserted-tooth cutter (*The Brown & Sharpe Manufacturing Company*)

power to operate, and reduces the tendency to chatter. It has *smooth action*. When of considerable length relative to the diameter, these cutters are called *slabbing cutters*. Slabbing cutters are frequently made with nicked teeth, the nicks following each other



Fig. 6-14. Plain milling cutters. (*National Twist Drill and Tool Company*)

alternately. The object of the nicks is to break up the chip and make it possible to take a coarser feed.

Right- and left-hand helix cutters may be mounted together on the arbor when taking heavy cuts, to avoid excessive end thrust on the machine spindle.



a

Fig. 6-15. Helical milling cutters: (a) hole type; (b) arbor type. (*The Brown & Sharpe Manufacturing Company*)



b

When a cutter has an especially steep helix (Fig. 6-15), it is called a *helical milling cutter*. Increasing the spiral (helix angle) to the degree shown seems to give increasingly smoother action. Figure 6-15 illustrates both the hole type and the arbor type.

*Metal-slitting Cutter* (Fig. 6-16). This is essentially a thin plain milling cutter, the sides of which are finished true by grinding. These

cutters are ground a little thinner toward the center; that is, they are given clearance toward the center in order that the sides of the cutter will not rub in the groove.

*Side-milling Cutter.* Figure 6-17 shows a side-milling cutter. This is a plain milling cutter with the addition of teeth on both sides. *Side mills* are frequently used in pairs with a collar between, and when so used are often called *straddle mills*. Pieces such as bolts, nuts, tongues, etc., that are to be milled on two parallel sides can be easily and accurately machined with a pair of side mills.

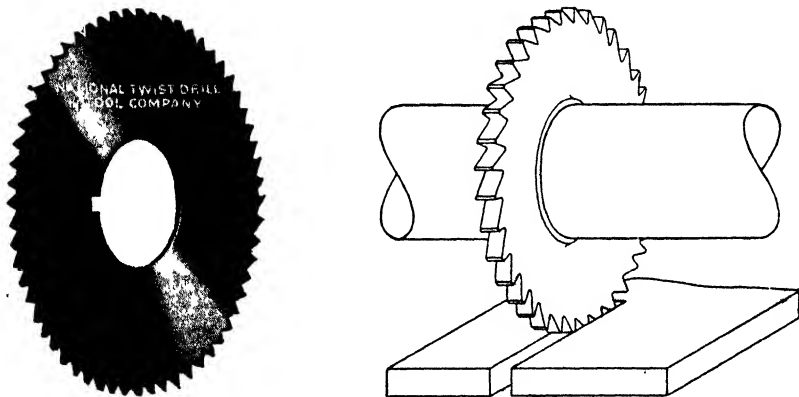


Fig. 6-16. Metal-slitting cutter: (a) cutter; (b) sawing action. (*The National Twist Drill and Tool Company*)

For milling slots to a standard width the interlocking side-milling cutter (Fig. 6-18) may be used. This cutter is made in two parts; in fact, there are two distinct cutters, with the inner surfaces of both parts milled to interlock. Even with repeated sharpenings the correct width of the slot may be maintained by placing thin metal washers between the hubs. If the cutters were not "interlocking," a ridge as wide as the space between the cutters would be left in the work.

*End Mills.* These cutters have teeth on the periphery and at the end (see Fig. 6-19). Most end mills have a taper shank which fits into a collet (Fig. 6-38) or an adapter (Fig. 6-39). End mills may be used for a large variety of light milling operations, such as machining the edges of fairly thin pieces, for squaring the ends of smaller

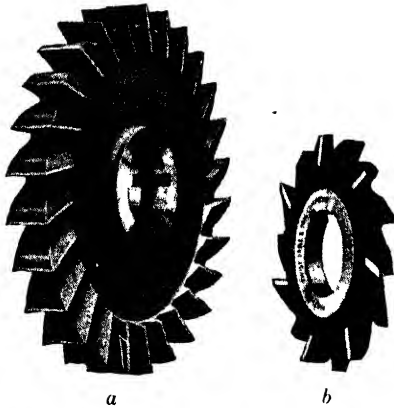


Fig. 6-17. Side-milling cutters: (a) plain; (b) staggered tooth. (*The National Twist Drill and Tool Company*)



Fig. 6-18. Interlocking side-milling cutter. (*The O.K. Tool Company*)

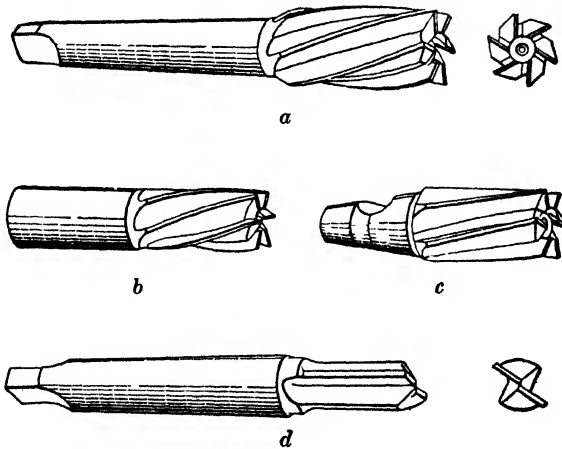


Fig. 6-19. End mills: (a) taper-shank spiral and mill; (b) straight shank end mill; (c) cam-lock shank; (d) two-lip end mill.

pieces, and often for making a corner cut (shoulder) where a fillet is desired. For slots or keyways it is often impossible to use any other form of cutter. End mills of a size over  $\frac{1}{4}$  in. are usually made with helical teeth.

In *d*, Fig. 6-19, is represented a two-lipped slotting end mill, sometimes called a cotter mill (from the English term *cotter*, or key). It is used for cutting slots and keyways. These mills, having end



Fig. 6-20. Shell end mills and arbor. (*The Brown & Sharpe Manufacturing Company and The O.K. Tool Company*)

teeth to the center similar to the lips of a drill, may be used for milling deep slots from the solid metal where there has been no drilled hole provided for starting the cut. The best results are obtained by a high surface speed with (1) a fairly deep cut and fine feed, or (2) a fairly shallow depth of cut with a medium feed. Use plenty of cutting lubricant.

*Shell End Mills.* End mills over 2 in. in diameter are made detachable from the shank, as shown in Fig. 6-20. These are known as *shell end mills* and are designed for the purpose of economy in replacing the cutter without necessarily replacing the shank. Shell end

Standard T Slots

Diam. of bolt	Width of throat A	Width of T slot B		Depth of T slot C		Depth of throat D	
		Max.	Min.	Max.	Min.	Max.	Min.
1/4	9/32	9/16	1/2	15/64	13/64	3/8	1/8
5/16	11/32	21/32	19/32	17/64	15/64	7/16	5/32
3/8	7/16	25/32	23/32	21/64	19/64	9/16	7/32
1/2	11/16	31/32	29/32	25/64	23/64	11/16	5/16
5/8	7/8	11/4	13/16	31/64	29/64	7/8	7/16
3/4	11/16	115/32	13/8	5/8	19/32	11/16	9/16
1	11/4	117/32	13/4	53/64	25/32	11/4	3/4
1 1/4	19/16	27/32	21/8	13/32	11/32	19/16	1
1 1/2	115/16	221/32	29/16	111/32	19/32	115/16	1 1/4

The minimum diameter of the width of throat *A* is the diameter of the bolt. The cutter is made maximum sizes (*B* and *C*) to allow for sharpening. The diameter of the neck of the cutter is made a trifle smaller than the bolt size for clearance, and the length of the neck is somewhat longer than the maximum depth of throat *D*.

mills have a standard-size hole of the proper diameter and have a slot milled diametrically across the back to fit a tongue on the arbor. The cutter is held on the arbor by a cap screw.



Fig. 6-21. Face-milling cutter. (The Brown & Sharpe Manufacturing Company)

*Facing Cutter.* The larger sizes (diameters) of cutters having teeth on one end or face are not provided with shanks but are fastened on the end of the machine spindle. They are called *face-milling cutters*, or *face mills*, and are usually made with inserted teeth (see Fig. 6-21).

*T-slot Cutter* (Fig. 6-22). This form of cutter is used for finishing T slots in worktables, etc. The central groove is milled with a side mill or an end mill, and then the wider part is milled

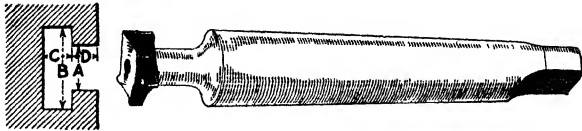


Fig. 6-22. T-slot cutter.

with the T-slot cutter. It will be observed that every other tooth is cut away alternately on each side. This makes for greater freedom of chip movement and greater ease in sharpening.

*Angular Cutters* (Fig. 6-23). The cutting teeth of an angular cutter are neither parallel nor perpendicular to the axis of the cutter but are at some oblique angle, such as 60, 70, or 80 deg. These cutters are used to cut teeth in ratchet wheels, for milling dovetails, etc. Sometimes the straight side is provided with teeth to give a better finish with this side when cutting grooves.

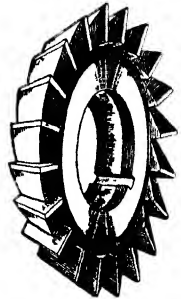


Fig. 6-23. Left-hand angular milling cutter.

*Double-angle Cutters.* In Fig. 6-24 at *a* is shown a double-angle cutter which is used for cutting spiral teeth in milling cutters, etc., and *b* illustrates how this cutter is set to obtain a radial tooth. These cutters are usually made with an angle of 12 deg. on one side and 40, 48, or 53 deg. on the other. The illustration shows a formed-tooth cutter, which has a much longer life than the saw-tooth cutter.

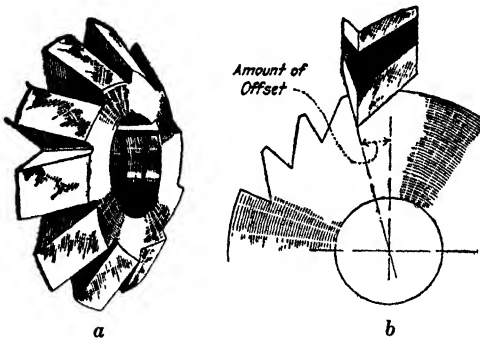


Fig. 6-24. (a) Double-angle cutter, left-hand, for fluting cutters with sawlike teeth, either straight or spiral; (b) cutter off set, to give radial face.



Double-angle cutters as shown, either right-hand or left-hand, also double-angle cutters for milling symmetrical 90-deg. V's are made in many sizes with either saw teeth or formed teeth.

*Tap and Reamer Cutter.* Figure 6-25 illustrates a cutter for grooving taps and reamers, and *a* and *b* show the manner in which the cutter is set to give a radial tooth. This cutter is substantially a double-angle formed-tooth cutter with the points of the teeth well rounded.

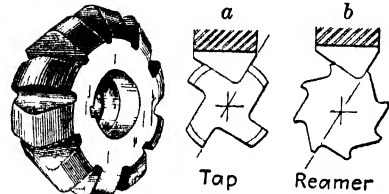


Fig. 6-25. Tap and reamer cutter.

Tap and reamer cutters are made in several sizes, and each size is stamped with the range of the diameters of taps and reamers for which it may be used.

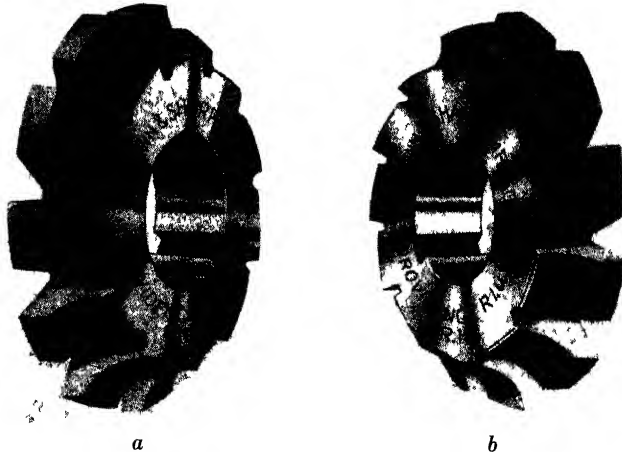


Fig. 6-26. Corner-rounding cutters (a) left-hand, (b) right-hand (The Brown & Sharpe Manufacturing Company)

*Corner-rounding Cutters.* Figure 6-26 shows left-hand and right-hand corner-rounding cutters, which are used for the purpose of finishing the corners and edges of work. These cutters are made for any desired radius.

*Convex and Concave Milling Cutters.* Figure 6-27 shows convex and concave formed milling cutters used for milling half circles or parts of half circles.

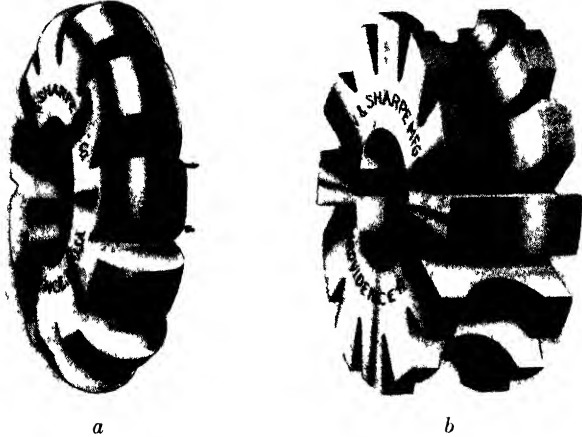


Fig. 6-27. Convex and concave cutters. (a) convex, (b) concave (The Brown & Sharpe Manufacturing Company)

*Fly Cutter.* The simplest form of cutter is the fly cutter, several shapes of which are shown in Fig. 6-28 together with the fly-cutter

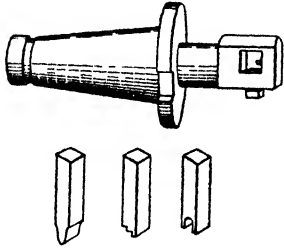
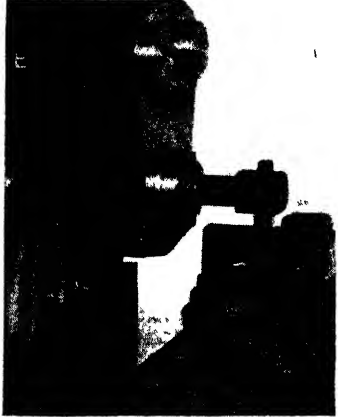


Fig. 6-28. Fly-cutter arbor and typical cutters

Fig. 6-29. Using a fly cutter Set the spindle speed for the diameter of the swing of the cutter Use a fine feed →



holder or arbor. It is a very useful form of cutter for experimental or hurry-up jobs where it would be impracticable, on account of the

time and expense necessary, to make a regular formed cutter. It is simply a piece of square steel, the end of which is formed (usually filed) to the desired shape, backed off and hardened. The shank of the arbor fits the taper hole in the milling-machine spindle, and the tool should be tightly clamped in the arbor. A fly cutter in use is shown in Fig. 6-29.

**Milling-cutter Materials.** The function of the milling cutter is no different from that of the tool bits, drills, reamers, etc., used on other machines; that is, the milling cutter must be able to remove metal efficiently and satisfactorily. To discharge this function, the materials used in the manufacture of milling cutters must be *stronger* and *harder* than the material being cut, and sufficiently tough to resist shock resulting from the cutting operation.

Not all the desirable qualities of any cutting tool are found in any one material, and the selection of the cutting material to use in a particular application depends to a certain degree on its properties. This has resulted in the development of a large variety of cutting materials, which may be grouped as follows:

1. Tool steels—carbon tool steel and high-speed steel.
2. Cast tool materials—cast high-speed steel and cast nonferrous tool materials.
3. Sintered or cemented carbide tool materials.

Each of these groups will be briefly discussed.

*Tool Steels.* The name *tool steel* has been given to all cutting materials which have iron as their chief constituent. They consist of a mixture of various elements, obtained by fusion at high temperatures.

When carbon is the only major element added to iron, the resulting product is called steel or carbon steel. The names *alloy carbon tool steel* and *alloy tool steel*, or *high-speed steel*, are applied to those steels in which other elements, such as tungsten, cobalt, chromium, vanadium, etc., are present, in addition to carbon.

Both carbon and alloy tool steels are used for all types of milling cutters. Cutters made of these steels are used for milling operations on parts made of all kinds of materials, including aluminum, bronze, brass, bakelite and plastic, as well as cast iron and steel, with due consideration, however, for the limitations imposed by the physical properties of both the material being cut and the cutting material used. This applies, in general, to all kinds of cutting materials.

Plain carbon tool steel is not widely used for milling cutters because of the rapid loss of hardness at temperatures above 400° F. Milling cutters made of this type of steel are used successfully for screw slotting and slitting, and for other light work. This is especially true for those carbon tool steels of *low* carbon content, known at times as *low-carbon* steel.

Plain carbon tool steel, with a higher carbon content, when used in making milling cutters, is a better material than the low-carbon steel. Carbon steels having a carbon content of 1.10 to 1.30 per cent are known as the *high-carbon* steels. They are used, as a rule, for finishing cuts and for accurate form tools.

Alloy tool steels form one of the most important and widely used groups of cutting-tool materials. They are commonly known as *high-speed steels*, since they can be operated at speeds of 2½ times those of carbon tool steels. These steels when used as cutting tools may be operated to temperatures up to approximately 1100° F., well above the low 400° F. at which the carbon steels lose their temper.

High-speed steels consists of iron with various amounts of carbon, chromium, tungsten, molybdenum, and vanadium. The latter elements combine with carbon, thus forming carbides, which give the steel such important properties as wear resistance, toughness, and strength.

Alloy steels have been named usually after the major alloying element; for example, tungsten high-speed steel is so called because tungsten is the chief alloying element; molybdenum high-speed steel, because the element molybdenum is the chief alloying element; etc.

*Cast-tool Materials.* Cast high-speed steels and cast nonferrous materials belong to the group of cast-tool materials because the tools made are usually shaped by the use of a mold.

Cast high-speed-steel cutters can be operated at high cutting speeds and are used for machining such materials as armor plate and aluminum.

Cast nonferrous tool materials are cast to the desired shape, are fully hardened after cooling to room temperature, and are finished to size by grinding. They are used for machining cast and malleable iron, semisteel, cast and forged steel, stainless, and other alloy steels.

Since cast nonferrous tool materials are brittle and cannot withstand shock, the cutter must not be stopped in the cut.

*Cemented Carbides.* The choice of the cutter will, in the majority of shops, be controlled by the limits of availability. There are, however, factors which must always be considered. For example, if there are a large number of pieces to mill, a milling cutter with sintered carbide-tipped teeth may be considered. The use of cutters tipped with various types of sintered carbides is becoming more common in machine shops, not only in the large mass-production shops but also in the small shops where the high cutting speeds and the fast feeds made possible by this type of cutter greatly affect production costs.

Many small shops make up their own face-milling cutters by inserting a carbide-tipped tool bit into a homemade holder, forming a single-point cutter often referred to as a *fly cutter*. When a large amount of metal is to be removed, the number of tool bits is increased to four and so inserted into the holder that each tool bit moves in an independent arc, each taking its share of the total cut.

The use of cemented carbides was at one time restricted to the machining of cast iron but has rapidly outgrown this, with very successful results. Cemented carbides are being used to machine every metal, from soft aluminum and magnesium alloys to tough alloyed steel. Because of the extreme hardness of these carbides, cutting speeds and feeds have been increased tremendously over those found possible with high-speed steel. For the same reason it has been found possible to reduce the allowance left for finishing, which results in a greater production with less operating cost.

There are various grades of cemented carbides, each with an individual number which denotes varying alloys and alloy combinations. There is no one grade of carbide that is suitable for machining all metals under any condition. For the efficient use of cemented carbides there must be a matching of tool-cutting material with the material to be cut. For this reason, there are many different grades of carbides, so that the many different machining conditions can best be met.

The condition of the machine is another important factor in the selection of the cutter. A machine must be rigidly constructed to withstand the strain set up by the fast speed and heavy feed made possible by the use of carbide-tipped cutters.

The type of coolant also is an important factor to be considered when cemented carbides are used. The wrong coolant will cause chipping or cracking of the cutting tip. An improperly applied coolant or an insufficient amount of coolant can also account for cracked and chipped tools.

In order to get maximum efficiency from carbide-tipped tools it is necessary to keep close watch that metal build-up on the cutting edge is removed as soon as it forms. It is not necessary to take the cutter from the arbor to do this for, when it is noticed in time, this metal can be removed from the cutting edge by honing.



Fig. 6-30. Carbide-tipped steel end mill (The O K Tool Company)



Fig. 6-31. Carbide-tipped cutters (The O K Tool Company)

There are many milling operations that cannot be satisfactorily accomplished by using cemented carbides; for instance:

1. Deep end-milling with small-diameter end mills.
2. Deep, narrow slotting operations.
3. Flimsy workpieces that cannot be adequately supported.
4. Complicated formed-cutter operations.

The successful use of carbides will depend upon the factors previously outlined. Whether this type of cutter is selected will be determined in large measure by where their use will prove profitable in time and result.

Practice and theory in the use of carbide-tipped milling cutters has been (and is still being) thoroughly analyzed by the research

department of the Cincinnati Milling Machine Company. There is much yet to be discovered in this field.

Sintered carbides are used in the form of tips which are brazed to inserted blades (Fig. 6-30) or directly to the body of the cutter (Fig. 6-31).

*Stellite.* Stellite is the trade name given to a group of steel alloys developed by the Haynes Stellite Company. This material retains its hardness even when "red hot." Milling cutters are cast to size and shape in Stellite, so that only a finish grinding is required. On large cutters the body, or hub, of the cutter is made of steel and the Stellite teeth are cast directly about the hub. Stellite gives best results in cutting cast iron.

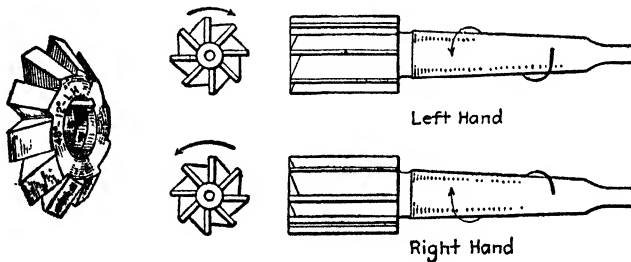


Fig. 6-32. Right-hand and left-hand cutters. At left is a 48- and 12-deg. left-hand double-angle cutter.

**Right-hand and Left-hand Cutters** (Fig. 6-32). Milling cutters are said to cut right-hand or left-hand according to the direction in which the cutter revolves when observed from the *back* of the machine or the back of the cutter. Cutters may be mounted on an arbor to be used either way, but angular cutters are marked *R* or *L*, assuming the angular teeth to be on the back side. Attention is called to the fact that a *left-hand* end mill is given a *right-hand* spiral, and vice versa, in order that the reaction against the tooth as it peels off the chip will tend to force the cutter toward the spindle rather than to loosen it. This is true also of spiral slabbing mills. It is customary, however, in heavy gang milling, as shown for example in Fig. 6-6, to use both right-hand and left-hand *spirals* to balance the force against the spindle-thrust bearing.

**Advantages of Coarse Teeth** (Fig. 6-33). The many practical experiments and tests that have been made with the purpose of

developing efficient milling cutters have clearly demonstrated the following advantages of the coarse-tooth cutters with the increased spiral, as compared with the previously recognized standards:

1. Ample chip space.
2. Increased strength of tooth.
3. Teeth may be undercut a little, that is, given *rake*, more advantageously.
4. More nearly perfect shearing cut, that is, less power required to remove a given amount of metal.
5. Free cutting action (larger chip per tooth) eliminating tendency of cutting edge to scrape or slide instead of cut, causing less friction and consequently less heat.

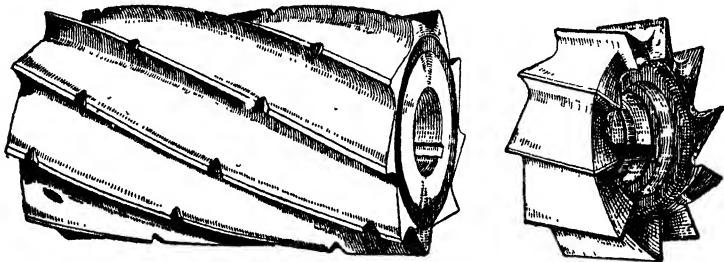


Fig. 6-33. Coarse-tooth milling cutters.

6. Longer life, less need for grinding; also may be ground a greater number of times and with less time spent at each grinding.

7. Notches, with clearance both sides, break the chip.

These advantages may be summarized thus: These cutters are capable of much greater production than the older style of cutter, and use comparatively less power.

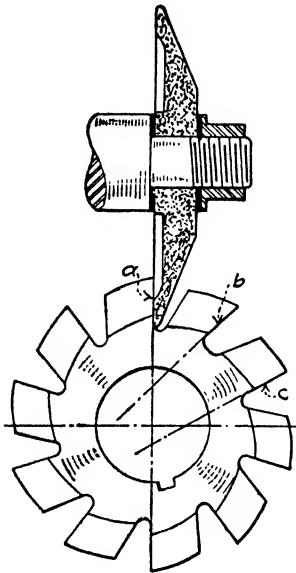
**Sharpening Cutters.** A milling cutter, like any other cutting tool, will do good work when it is correctly sharpened and under proper conditions will do a considerable amount of work before it is noticeably dull. If, however, it is operated when noticeably dull, the excessive friction generates heat enough to soften the teeth, and it will soon become *very dull* and possibly be ruined.

To sharpen a dull cutter takes only a few minutes and reduces each tooth only a small amount. To sharpen a *very dull* cutter takes



a long time and a large portion of each tooth must be sacrificed. *Keep cutters sharp.*

Formed cutters are sharpened by grinding the face of the tooth radially, and all teeth alike. If one tooth is ground less than another it is longer and consequently cuts more than its share and dulls quickly. When not ground radially, they are either "hooking" as at *b*, Fig. 6-34, or "dragging" as at *c*. In either case, the true profile is not produced because the teeth are so made that the outline of the cutting edge is correct only when the teeth are ground radially.



**Fig. 6-34.** Sharpening a formed cutter. Tooth sharpened on face radially, as at *a*, will cut its shape; if ground hooking, as at *b*, or dragging as at *c*, it will not cut correct shape.

Cutters with saw teeth or inserted teeth are sharpened by grinding the lands. The angle of tooth clearance is a very important consideration. The clearance is the amount the top of the tooth (the land) is relieved (or "backed off") so that this part of the tooth will not rub on the work after the cutting edge has passed. If the clearance is too great, the cutter dulls rapidly and, if not enough, the cutter rubs and does not cut. The proper clearance angle should be about 7 deg. for cutters under 3 in. in diameter, and about 5 deg. for those over 3 in. The clearance on end teeth (and side teeth) should be about 2 deg., and in order to avoid the tendency to drag and thus score the surface of the work they should be ground 0.001 or 0.002 in. lower toward the center. That is, placing a scale across the diameter of the cutter would show the end (or face) to be slightly concave.

The various manufacturers of cutter grinders furnish booklets illustrating and explaining the operation of their machines, and the operator, the beginner especially, will find such information very

helpful. The information given in connection with Fig. 6-35 is fundamental and applicable in any cutter-grinding machine.

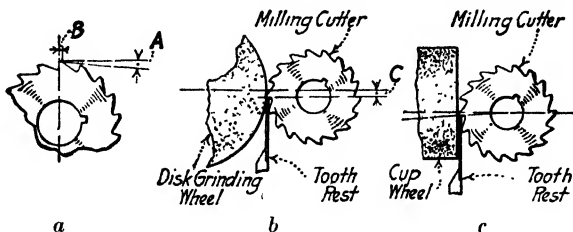


Fig. 6-35. Grinding the clearance on milling cutters. The angle of tooth clearance is measured from a line at right angles to the radial as shown, *A* representing the clearance, and *B* the land of the tooth. To obtain the clearance, the tooth rest must be given distance below the center of the cutter, as shown in (*a*) and (*c*). For the amount *C* to set the tooth rest below center, see Table 12, page 650.

When grinding cutters, use a soft wheel of medium grain (see Grinding Wheels). Keep the wheel clean and true and take light fast cuts to avoid drawing the temper of the cutter.

### HOLDING THE CUTTER

**Standardized Spindle End** (Fig. 6-36). The revolving main spindle of the milling machine carries with it the cutter. The spindle

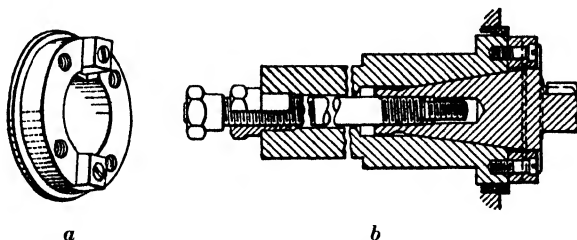


Fig. 6-36. Standardized spindle end. The method of holding arbors and adapters is shown in (*b*). The larger thread on the end of the draw-in bolt is used in most cases, but certain adapters, collets, etc., require the smaller thread.

is designed to hold and drive the cutter, whether arranged on an arbor, in an adapter, in a collet, or screwed on the nose of the spindle. Formerly the taper shank of the arbor was 0.5 in. per ft. B. & S.

taper (Fig. 6-37), and the end of the shank was provided with a tang to help hold and drive; but the present design, which fits the new standard spindle end, gives a much simpler and stronger drive besides many other advantages.

Manufacturers have adopted a standard spindle end and a complete series of arbors for all sizes of milling machines from 2- to 20-hp. In addition to securing interchangeability of all arbors and face-milling cutters in all makes of milling machines, and the consequent elimination of the great variety of sizes and kinds, the standard has retained and improved the best features of the older design.

1. The arbors are driven by two lugs instead of depending upon the hold of the taper plus the tang.

2. Since the taper is not used for frictional holding, but merely for centralizing the arbor or adapter, it is made with a steeper taper,  $3\frac{1}{2}$  in. instead of  $\frac{1}{2}$  in. per ft. Therefore the new design of arbor cannot "stick" in the spindle, and is quick releasing.

3. A draw-in bolt is used to pull the arbor tightly in place, obviating any chance of spoiling the work by the loosening of the arbor.

4. To remove the arbor, merely loosen the draw-in bolt part of a turn, tap the bolthead lightly, and then completely unscrew the bolt.

5. The entering end of the arbor is straight, and enters a straight part of the spindle hole, in order to have the tapped hole in line when putting in the drawbolt.

6. Various kinds of adapters are manufactured to make possible the use of older types of arbors, etc., in the newer machines.

7. An extension threaded end is provided on the drawbolt for securing auxiliary equipment, such as certain kinds of adapters.

8. Face-milling cutters are centralized on the spindle end, held by four bolts and driven by the two lugs.

**Milling-machine Arbors.** These arbors are made in various lengths and in standard diameters of  $\frac{7}{8}$ , 1,  $1\frac{1}{4}$ , and  $1\frac{1}{2}$  in. Figure 6-37 shows new and old style. The difference between the old and the new is in the taper shank. The shank of either is made to fit the taper hole in the spindle, and the other end is threaded to receive a nut. The remaining portion of the arbor is made cylindrical. Collars

are fitted freely over this part of the arbor and by means of the nut one or more cutters may be clamped between the collars. The collars, being of different lengths and removable, permit cutters of various lengths (or thicknesses) being clamped and also permit locating the cutters in the desired position on the arbor. The arbor is supported by the yoke from the overarm either by a center or in a bearing in the yoke. The bushing *B* which forms the journal in the outer bearing for supporting the arbor is of somewhat larger diameter than the collars and is ground to fit a bronze bearing in the arbor yoke. To avoid spring of the arbor, the bearing should always be located as

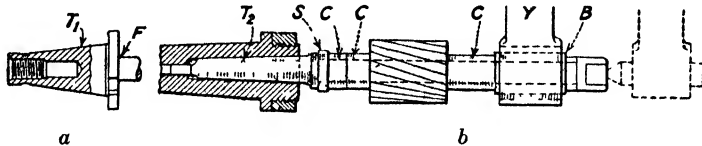


Fig. 6-37. Milling-machine arbor: *T*<sub>1</sub> shows modern type of taper shank; *T*<sub>2</sub>, old type of taper shank *F*, fillet, gives extra strength and stability; *S*, special collar to cover fillet; *C*, regular collars; *B*, special collar fits bronze bearing in yoke *Y*. The outer end of the arbor is threaded for a nut. In those machines (Brown and Sharpe, for example) where the cutter normally runs left-hand, the arbor and the nut are threaded left-hand, and thus the pressure of the cut does not tend to loosen the nut. Dotted lines show yoke center in end of arbor.

close to the cutter as will allow the yoke to clear the work and the vise or fixture that holds the work. For the same reason, the center should not be used unless it is impracticable to use the bushing in the bronze bearing.

The friction between the collars and the cutters is sufficient to hold the cutter for light cuts, but for heavy duty, the cutter *must* be keyed. Arbors are usually splined for keys.

Arbors which have the  $\frac{1}{2}$ -in. per ft. taper shank (old style) are driven home with a Babbitt hammer and are removed by means of a knockout rod.

**Collet for Taper-shank Mills.** End mills up to 2 in. in diameter are usually made solid with the shank. The shank, of a size to conform to the size of the cutter, may be (rarely) straight, or Brown and Sharpe taper ( $\frac{1}{2}$  in. per ft.), or, more recently, the steeper,  $3\frac{1}{2}$ -in. per ft. taper. Unless the size of the B. & S. taper shank is the same as

the taper hole in the spindle, it is necessary to use a collet (Fig. 6-38) to hold the cutter. It must be very carefully driven home with a hammer and a hardwood block. A milling-machine collet is the same sort of tool as the drill-press *socket* or the lathe *sleeve*, in that it serves to step the sizes of tapers. The taper, however, is *not* the same.

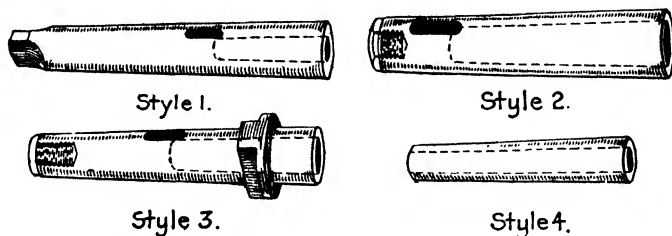


Fig. 6-38. Milling-machine collets. For adapters for standardized spindle end, see Fig. 6-40.

**Brown & Sharpe Cam Lock.** End mills with the steeper taper are held with the cam-lock adapter (Fig. 6-39). This adapter for stepping the steep-taper sizes gives a method of securely holding end mills and the like. It is not necessary to drive this adapter home.

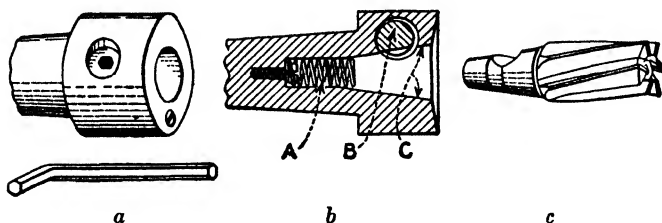


Fig. 6-39. (a) Brown & Sharpe "cam-lock" adapter. (b) Sectional view showing: A, the spring to keep the shank of the end mill floating to ensure correct seating; B, camlock, draws the end mill securely into taper and locks it there; C, standard milling-machine taper for quick release. (c) End mill with cam-lock shank.

A simple turn of the wrench turns a cam which quickly locks or releases the cutter.

All necessary cam-lock adapters, as well as the corresponding taper-shank end mills, and kindred cutters of every description, are commercially manufactured. Examples are illustrated in Fig. 6-40.

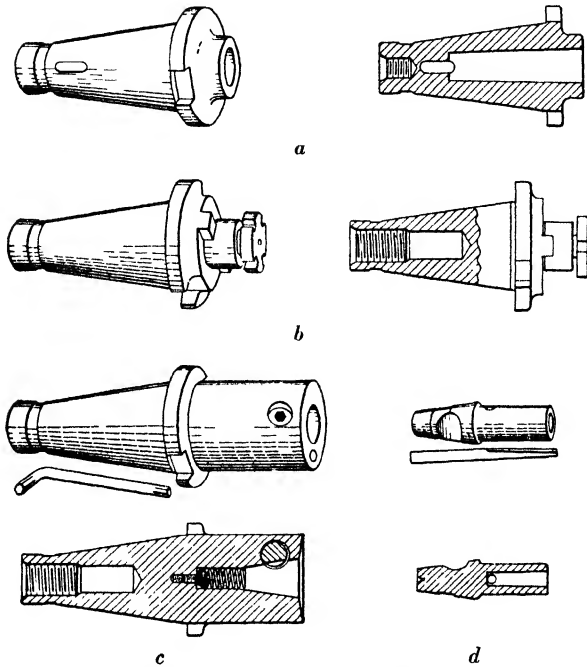


Fig. 6-40. Examples of adapters to fit the standard milling-machine spindle; *a*, for regular taper-shank end mills; *b*, for shell end mills; *c*, for the smaller Brown & Sharpe cam-lock collets, as in *d* or for end mills, etc., having cam-lock taper shanks.

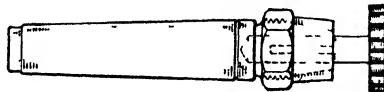


Fig. 6-41. Woodruff keyway cutter chuck. The front end of the arbor is slightly tapered for a short distance and then threaded, and the hole in the nut is correspondingly tapered and threaded. The end of the arbor is split by three equally spaced slots, and tightening the nut serves to grip the shank of the cutter. This type of chuck is often called a *spring* chuck.

**Holding Straight-shank Cutters.** End mills with straight shanks (*b*, Fig. 6-19) may be used if a special holding chuck is provided. Their cost is somewhat less than that of taper-shank mills of the same size, and in the smaller sizes they are very satisfactory. Most Woodruff keyway cutters are made with straight shanks.

Figure 6-41 shows a keyway cutter held in the spring chuck or "spring collet."

**Holding Face-milling Cutters.** The larger end-milling cutters are generally known as *face-milling* cutters. Face-milling cutters are mounted directly on the end of the milling-machine spindle, securely held by four bolts in such a manner as to locate the cutter accurately and drive it positively and also to make its removal easy.

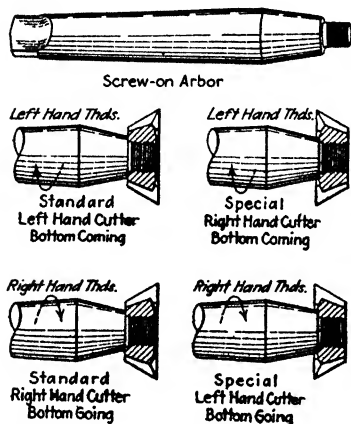


Fig. 6-42. Screw-on arbor and cutters. To avoid confusion when making or ordering right-hand or left-hand threads in right-hand or left-hand cutters, the four applications, two *standards*, and two *special*, must be considered.

### Screw-on Cutters and Arbors.

Many of the small cutters, such as corner-rounding, convex and concave cutters, and cutters for fluting the smaller sizes of end mills, reamers, counterbores, etc., are often of the form of screw-on cutters. The hole is tapped  $\frac{3}{8}$ -16 or  $\frac{1}{2}$ -16 and the screw arbor (Fig. 6-42) is threaded on the end to receive the cutter. In order that the cutter will not loosen and come off the arbor during the cut and thus spoil the work, right-hand cutters have right-hand threads

and left-hand cutters have left-hand threads. Screw-on cutter arbors are usually made either with No. 7 Brown and Sharpe taper shanks and fit into a collet, or with a cam-lock shank fitting an adapter.

## QUESTIONS ON MILLING CUTTERS

Obtain from the toolroom an example of each of the following milling cutters: Spiral mill, metal-slitting saw or slotting cutter, side mill, angular cutter, and end mill.

1. How large in diameter is this spiral mill? How long is the cutter? How wide is the face?
2. Roll the cutter fairly hard on a piece of paper and measure the angle of the tooth with the axis of the cutter. What is the angle of the spiral of the cutter?

3. What is a spiral milling cutter used for?
4. What is the advantage of the spiral tooth?
5. Lay the edge of a scale across the face of the slotting cutter. Why is it not made straight? Is the end of the spiral mill straight? Why?
6. What is meant by a plain milling cutter? Is the slotting cutter a plain milling cutter? Explain. Is the spiral mill a plain milling cutter?
7. What is the general shape of the tooth of the slotting cutter? Of the spiral mill?
8. How much clearance is given the cutting edges of these cutters? Why not more? Why not less?
9. Lay the edge of a scale across the face of the side mill, and look under it. Have the side teeth any other clearance than the tooth clearance? Give reason.
10. Is the length of the hub equal to the width (thickness) of the side mill?
11. If it is desired to use a pair of these side mills for straddle-milling will a collar be used which is the same thickness or length as the distance required between cutting surfaces? What thickness will be used?
12. Why should you think it advantageous to have thin metal collars or "washers" or "spacers" for obtaining the correct distance between straddle mills?
13. Do the side teeth of a side mill cut when straddle-milling? Of what use are they?
14. Could a side mill be used efficiently for cutting on one side only? Give reason.
15. What is meant by an interlocking cutter? How is such a cutter advantageous when milling slots of an exact width?
16. Examine the angular cutter. What angle is it? Is it so marked?
17. Is it a right-hand or a left-hand cutter? Is it so marked?
18. State how you can select a right-hand or a left-hand cutter that is not marked.
19. What is a double-angle cutter? What do you mean by a 90-deg. cutter? 60-deg. cutter?
20. What is the shape of a cutter for milling spirals? What is the difference between a 48-12-deg. cutter and a 53-12-deg. cutter?
21. What are the general characteristics of an end mill?
22. What is the largest size of solid end mill usually made? Why?
23. How are end mills of the larger sizes made? What is the advantage?
24. What is the cutter of still larger diameter with teeth on the face called?
25. When is an end mill useful for plain milling?
26. Is it advantageous to have the peripheral teeth of an end mill  $1\frac{1}{4}$  in. in diameter cut spirally? Of an end mill  $\frac{5}{8}$  in. in diameter?
27. What is the reason you cannot use an end mill as a drill?



28. What advantage has a cam-rock adapter?
29. What is a cotter mill? What is the advantage of having only two teeth?
30. How do you distinguish a right-hand end mill?
31. Of what kind of material is the body of an inserted-tooth cutter made? Of what kind of steel are the teeth made? What is the difference in the price of these materials?
32. If one tooth of a solid cutter breaks, does it affect the efficiency of the cutter? Can a solid cutter with a broken tooth be repaired? How may such a repair be made on an inserted-tooth cutter?
33. Can a worn-out solid cutter be remade to original size and shape? How can an inserted-tooth cutter be remade? What would be the cost of remaking compared to a new solid cutter?
34. Is it easy to harden a large solid cutter? Can you guarantee it will not crack?
35. Is it easy to harden teeth for an inserted cutter? Suppose one or two of the teeth are cracked, what would you do?
36. How are you able to shim under the teeth of an inserted cutter if necessary? When may this be advisable?
37. State all the advantages you believe an inserted-tooth cutter has.
38. Obtain from the toolroom a formed cutter: a gear-tooth cutter will do. What is meant by a formed cutter?
39. Can you explain how, in the process of making the cutter, the teeth of the cutter are formed to the irregular shape and "backed off" at the same time?
40. When the cutter is being formed and relieved (backed off), the forming tool is held exactly on center. Why is this necessary?
41. What part of the formed cutter is ground when necessary to sharpen the cutting edge?
42. How should the formed cutter be ground to preserve the original shape of the cutting edge? Why?
43. When should a formed cutter be ground? Why? How much of the tooth may be ground without destroying the original shape of the cutting edge? Why?
44. Why is a double-angle cutter, or a cutter for cutting spiral mills, or a reamer-grooving cutter, usually made with formed teeth rather than with saw teeth?
45. What is a helical cutter? State two advantages that it has.
46. How many reasons can you give for the efficiency of the formed cutter?
47. What is a fly cutter? When is it advantageous to make and use a fly cutter? How is a fly cutter held?
48. When making the fly cutter, what is the object of turning (forming) the cutter with the liner behind it?

49. The tendency of the manufacturers is to substitute, whenever possible, for the radial face on the teeth of milling cutters a face having a rake of about 10 deg. Further, since high-speed steel has largely superseded carbon steel for milling cutters, the tendency has been toward coarser teeth. What is the advantage of rake on milling-cutter teeth?
50. What are two advantages of coarse teeth on milling cutters?
51. Are formed milling cutters given a spiral cut? Give reason. Are they given rake? Give reason. Do they have coarse teeth?
52. Why do the longer spiral milling cutters have nicked teeth? How is the nick given clearance? Why is it given clearance?
53. Why is a right-hand spiral cut on a left-hand end mill?
54. Why are small-diameter cutters made with shanks?
55. What is the reason for making some cutters screw on a shank?
56. Why does a left-hand screw-on cutter have a left-hand thread?
57. What is a T-slot cutter? Why do you have to remove the central portion of the T slot before using the T-slot cutter?
58. If you go to the toolroom to obtain a milling cutter, how do you specify the cutter you wish?
59. It may be stated that half the life of many cutters is wasted by running when dull. Explain in detail.
60. How many of the various kinds of cutters listed in a catalogue of cutters are you able to find and examine?

## Speed, Feed, and Depth of Cut

The output of a machine is dependent, among other things, upon the efficiency of the cutting tool. To remove a given amount of metal, the cutting tool is efficient only when operated at the proper depth of cut and the proper speed and feed. Therefore, in the matter of production, the question of cutting speeds and feeds is of extreme importance to the employer. And, in the matter of making good, a knowledge of the conditions that enter into the question, "What is the right speed, feed, and depth of cut for this job?" is of great importance to the machinist.

**Cutting Speed.** As the work is fed against the revolving milling cutter, each tooth peels off a chip. The amount of metal removed in a given time depends on the width of cut, the depth of the cut, the thickness of the chip (fine feed or coarse feed), and the speed of the cutting edge through the metal (cutting speed). The width of cut, the depth of cut, the feed, and the speed are all variables. The feed and depth of cut are more or less matters of judgment, and conditions governing them will presently be explained; the cutting speed, however, is governed by practically fixed conditions.

As the work is fed against the revolving cutter, the rate at which the chip is cut is the cutting speed. In other words, the cutting speed of a milling cutter is the speed in *feet per minute* of the cutting edge of a tooth as it peels off its chip.

Taking the cut causes friction between the cutter and the work, and friction generates heat. When a cutter is overheated, the temper is destroyed and in many cases the cutter is ruined. The heat generated in cutting any material depends upon the hardness and toughness of the material being cut; the harder and tougher the metal, the more heat is generated and, therefore, the slower the cutting speed must be.

Because of its peculiar properties, a cutter made of high-speed steel may be run at double the speed (or more) of a carbon-steel cutter without spoiling the temper; consequently, the kind of material from which the cutter is made is an important factor in determining the cutting speed.

Other factors besides those mentioned in the above paragraph influence the cutting speed of milling cutters. Some of these are: (a) the amount of material to be removed, (b) the cutting fluid used, (c) the relation of depth of cut and feed, and (d) the finish desired.

Since milling machines are now built to take heavier, faster cuts with high-speed steel cutters, and since these cutters are now practically as low priced as carbon-steel cutters, there seems to be no reason to use the carbon-steel cutters except in special cases.

The use of carbide-tipped milling cutters is quite common, even in small plants, if the machines have the speed and power required for such use. Although these cutters are a bit more expensive than the high-speed steel cutters, machine shops are using them to reduce unit-production costs and at the same time, save the sharpening time allowed for the cutters. Great care must be exercised in the selection of the proper *grade* of carbide for the particular material. Also, in sharpening, special facilities are required, as well as skill and extra carefulness. For general machine-shop milling, the high-speed steel cutter, properly set for speed, feed, and depth of cut, is more efficient.

Iron castings of different chemical compositions and steels of different manufacture vary so much in their hardness, especially the carbon steels and the alloy steels, that it is impossible to offer a table except for average cutting speeds. What would be a safe speed for one kind of tool steel, for example, would utterly ruin a cutter in a short time on another kind of tool steel. The *average* cutting speeds used in machine-shop practice when machining with high-speed steel cutting tools are:

High-speed Steel Cutting Tool	Cutting Speeds, Ft. per Min.
For tool steel	70
For machine steel	90
For cast iron	90
For brass	200

When carbon-steel cutters are used, about half of the above speed is required.

It is advisable to start with a comparatively slow speed and advance this speed from time to time, if it is found possible to do so without stopping too often to sharpen (and change) the cutter.

**Cutting-speed Calculations.** The cutting speed of a milling cutter is the speed in *feet per minute* of a point on the circumference of the cutter. The number of revolutions per minute necessary to give the required cutting speed depends on the size of the cutter. Naturally, for a given cutting speed, the smaller the cutter, the faster it must run.

The cutting speed of the common metals used in machine-shop work is known and is usually controlled by *setting* the speed of the milling-machine spindle. For example, in order that a metal be cut at any desired speed, all the operator has to do is to calculate the revolutions per minute (r.p.m.) of the spindle, set the speed-control lever or dial to the nearest available speed, and the machine will cut at the desired speed.

To obtain the revolutions per minute necessary to give the required cutting speed, use the following formula:

$$\text{R.p.m.} = \frac{4\text{CS}}{D}$$

where CS is the proper cutting speed for the metal being cut, and  $D$  is the diameter of the cutter.

**EXAMPLE:** It is desired to mill a piece of machine steel at a speed of 35 f.p.m. (feet per minute) with a cutter 2 in. in diameter. How fast must the cutter revolve?

**SOLUTION:** Using the above formula and substituting the given values for CS and  $D$  in the formula, we get

$$\text{R.p.m.} = \frac{4 \times 35}{2} = 70$$

Set the spindle speed as near 70 r.p.m. as possible.

### MILLING-MACHINE FEEDS

**Definitions of Feed.** (1) Theoretically the feed of a milling cutter is the thickness of the chip per tooth of the cutter, that is, the dis-

tance the work advances against each succeeding tooth of the cutter. (2) In cone-pulley-driven machines the amount of feed is dependent on the spindle speed and is often rated as the distance the table moves per revolution of the spindle. (3) In milling machines having a constant-speed drive, the feed mechanism is usually independent of the number of revolutions of the cutter, and in these machines the feeds are arranged to move the table a certain distance per minute. For this reason it is now quite proper to speak of milling-machine feed as so much per minute, as 1-in. feed, or 10-in. feed, etc., meaning that the table feeds that distance in 1 min. The particular definition of feed is unimportant, the question is one of *proper amount*.

**Conditions Governing the Amount of Feed.** The problem of proper milling-machine feeds offers one of the most interesting and one of the least understood questions in machine-tool operation. There are so many conditions that enter into the question of feeds, that hard and fast rules are impossible. The depth of cut and the width of cut, also whether it is a roughing cut or a finishing cut, in other words, the amount of metal to be removed and the appearance desired are factors. Further, the diameter of the cutter; the number of teeth in the cutter; the proportion of thickness to the diameter; the speed at which the cutter is revolving; the way in which the cutter is held; the power and rigidity of the machine; and the rigidity of the work are all factors which must be taken into consideration in obtaining efficient feed.

**Analysis of Cutting-feed Conditions.** First, it will be understood that in any operation of cutting metal a considerable force is exerted against the piece being cut and equally against the cutter itself; and that the amount of metal removed (feed and depth of cut) is in proportion to this force. Therefore, the proper depth of the cut and the proper amount of feed depend to a certain extent upon each other and, in addition, both depend on the power and rigidity of the machine itself.

Second, the correct depth of cut and feed depend on the strength of the cutter and the rigidity with which it is held, and the strength of the work and the manner in which it is held. For example, a slender end mill or a thin slitting cutter cannot be given heavy duty; neither should a frail piece of work or a piece held in such a manner that it may spring or bend be given a heavy cut or feed.

Third, the teeth of the coarse-tooth cutter are proportionately stronger than the finer teeth, the chips wash out more readily, and the cutting fluid keeps the cutting edge cooler. For these reasons a heavier chip may be taken with a coarse-tooth cutter.

Fourth, while the coarse feed removes metal faster, the appearance and accuracy of the surface are not as good as is desirable for finished work; therefore, a finer feed is used for finishing.

An example will serve to show the action of a milling cutter. A cutter 3 in. in diameter cutting 35 ft. per min. will make 45 r.p.m. If this cutter has 12 teeth, then 12 chips will be cut each revolution; and 45 multiplied by 12 equals 540 chips per minute. If the feed is 6 in. per min. and 540 chips are cut per minute, each chip is 0.011 thick. This is theoretical; no milling cutter runs exactly true, but even so, probably no chip will be over  $\frac{1}{64}$  in. thick.

In ordinary milling practice, when using a fair-sized carbon-steel formed cutter on machine steel, with a good flow of cutting compound, a feed of 4 or 5 in. per min. is not excessive. With a coarse-tooth helical cutter 6 or 8 in. per min. is not too much to try and may probably be increased. Since cast iron must be cut dry, the feed is reduced about one third. High-speed-steel cutters running at about double the speed of carbon-steel cutters will stand up well under practically double the feeds (*in inches per minute*) of the carbon-steel cutters.

The general tendency is to *overspeed* and *underfeed* a milling cutter. The reason for most of the too quickly dulled cutters is too much speed, and rarely if ever too much feed. It will be well for the beginner to go fairly slowly at the start and avoid spoiling the cutter, the work, or possibly both, but to keep right on the job with the idea of advancing the speed or the feed as much as possible with due regard to the time it takes to sharpen the cutter.

**Depth of Cut.** On most work no more than two cuts are required—a roughing cut and a finishing cut. If it happens that two or more cuts are necessary, the rule is to take, for the roughing cuts, a coarse feed and about all the depth of cut the machine, cutter, and work will stand.

As in shaper or planer work, care must be taken when milling cast iron that the edges at the end of the cut are not broken away below the finished surface. Milling fixtures, special vise jaws, etc., for

manufacturing are designed to back up the metal at this point, thus overcoming the tendency of the corners to break off, but in many special jobs it may be necessary to feed carefully, by hand, toward the end of the cut.

**Finishing Cut.** Remember that attention to the slogan "keep cutters sharp" is one of the main factors in good milling; bear in mind that a surface that has been milled with a good sharp cutter is as accurate as a filed and polished surface. Also it is easier and quicker, and therefore cheaper, to mill to size than to finish by filing and polishing.

When it is advisable to make two cuts, a roughing cut and a finishing cut, leave at least  $\frac{1}{64}$  in. for the finishing cut. In any machine a cutting tool will do better work and last longer if the edge has a chance to get under the chip, where it has less tendency to rub.

There is always spring in every milling operation. If the feed is stopped while the cutter revolves on the work, the surface will be defaced by an undercut. *Do not throw out the feed on a finishing cut.*

For the same reason as above, if a cut just made is run back under a revolving cutter, the work will be marked each revolution of the cutter. Stop the cutter before running back or else lower the work a trifle.

**Lubricating the Cutter.** A cutting fluid should always be used in milling steel or wrought metals. It serves to wash away the chips, produce a better finish, keep the cutter cool, and give a longer life to the cutting edge. A good quality of mineral lard oil is an excellent cutting lubricant. There are, however, several specially prepared cutting compounds (soluble oils) on the market which are cheaper than lard oil and, for most operations, serve the purpose. Provision is made in all milling machines to save the cutting compound and use it over and over again. The manufacturing milling machines are equipped with a pump to effect the circulation and provide a steady stream of the size and force desired. The smaller machines and the universal machines are also equipped with pumps. The cutting compound should be used freely but should not be wasted, that is, should not be allowed to drench the machine and the floor. Remember, cast iron is always machined dry.

**Direction of Cutter and Feed.** It is usually considered better practice to feed the work against the cutter as shown at *a*, Fig. 7-1



rather than with cutter as shown at *b*. There are two good reasons for this: When the work is fed in the direction opposite to that in which the cutter revolves, the teeth do not come into contact with

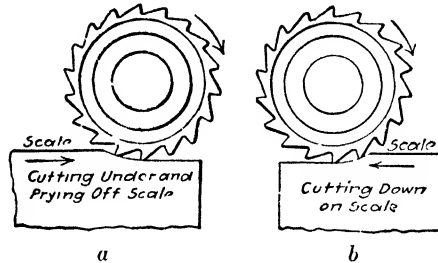


Fig. 7-1.

the scale, and also the backlash in the feed screw is taken up against the force of the cut, preventing any tendency of the cutter to “dig.”

**NOTE:** As an exception to the above, when cutting off stock and when milling comparatively deep or fairly long slots, there is less tendency for the cutter to crowd sidewise, thus making a crooked cut and possibly breaking the cutter, if the slotting cutter is operated as shown at *b*, Fig. 7-1.

The direction of the cutter with regard to the manner in which the work is held is important. (1) The arrangement should be such that any tendency of the work to spring will be in a direction away from the cutter. (2) The arrangement should be such that there will be no tendency to loosen or displace the work.

**CAUTION:** To run a cutter “backward” will break the teeth. Be very sure the cutter is mounted on the arbor to revolve in the proper direction and that the machine spindle is arranged to revolve in that direction.

## QUESTIONS ON SPEED, FEED, AND DEPTH OF CUT

1. What conditions govern the cutting speed of a milling cutter?
2. What is the difference between revolutions per minute and feet per minute?

3. What is the average cutting speed for the different metals used in machine construction when using carbon-steel cutting tools?
4. How many revolutions per minute should a carbon-steel milling cutter 3 in. in diameter be run to cut machine steel?
5. What is the formula for calculating revolutions per minute of milling cutters, having given the diameter of the cutter and the required cutting speed?
6. Having calculated the revolutions per minute, how do you set the spindle speed? Can you set it exactly right? Give reason.
7. How do you define milling-machine feed?
8. State at least six conditions that govern the amount of feed in milling.
9. How many different rates of table feed may be obtained in the machine you are running?
10. Generally speaking, how much of a chip may be taken in the roughing cut?
11. State three reasons why a dull cutter should not be used.
12. How much should be left for a finishing cut? Why?
13. What would happen if the finished surface is run back under the revolving cutter? How is this avoided?
14. What is the value of cutting fluid?
15. What is the general rule concerning the direction of the cutter and the feed? What are the reasons? State an exception to this rule.

## Typical Milling Setups and Simple Operations

### HOLDING THE WORK

The success of modern industry in producing machine parts of identical size and shape has been due, in large measure, to the versatility of the milling machine with its variety of attachments.

The milling machine has superseded the engine lathe as the most versatile machine in the metal-working industry by reason of its ability to machine several surfaces with one movement of the table

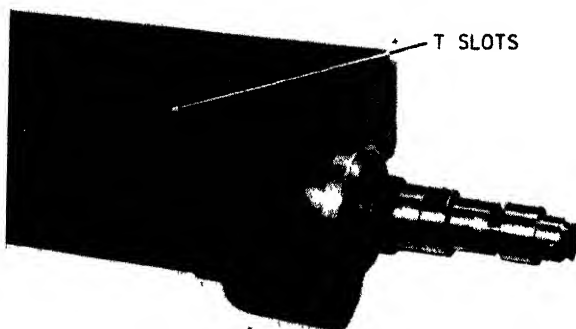


Fig. 8-1. The T slots on a milling-machine table. (*The Brown & Sharpe Manufacturing Company*)

and the diverse methods by which work can be set up and securely fastened.

**Clamping Work to the Table.** The table of the machine provides a surface upon which work and the work-holding fixtures and attachments can be fastened. The T slots, which run lengthwise along the table, are used for locating and aligning the work as well as retaining the bolts used for clamping (Fig. 8-1). The T slots are

accurately machined to size and are parallel to the sides of the table. The upper part of the slot provides an easy but accurate method of aligning work-holding fixtures and attachments. Milling-machine fixtures and attachments are usually fitted with keys mounted on the base for that purpose

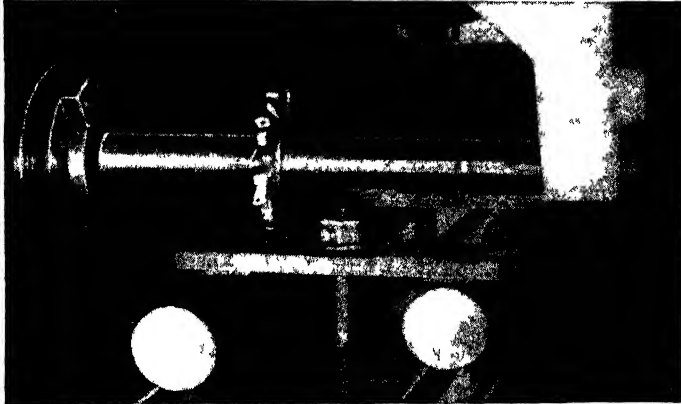


Fig. 8-2. Cutting a keyway in a 2-in shaft (James Anderson)

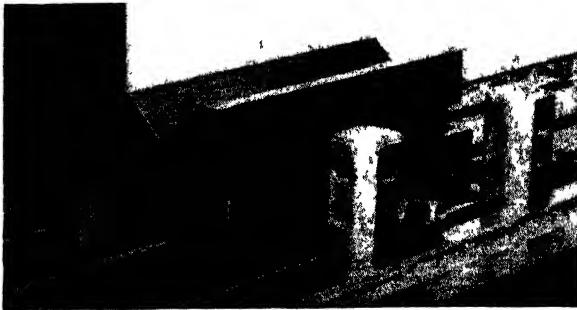


Fig. 8-3. Using upright, parallels, screws, and poppets (James Anderson)

The T slots are often utilized to do the work of V blocks when keyways are machined in round stock or shafting (Fig. 8-2). This method is not suitable for work requiring extreme accuracy, for with service, the edges of the T slots become worn and “out of true.”

The T slots can also be used to align work by means of upright parallels fitted firmly in the upper part of the slot, against which the work is clamped by means of toe-dog screws and poppets (Fig. 8-3).

Clamping the work to the table is common practice when castings of bulky size and irregular shape require milling (Fig. 8-4). The uneven surfaces of rough castings require the use of shims and wedges to remove any "rock"<sup>1</sup> they may have *before* they are strapped down to the table. If this precaution is not taken, a twist will appear in the finished job as soon as the clamps are released.

The principles of clamping work to the table, angle plates, V blocks, etc., are the same as for all types of machine work. These

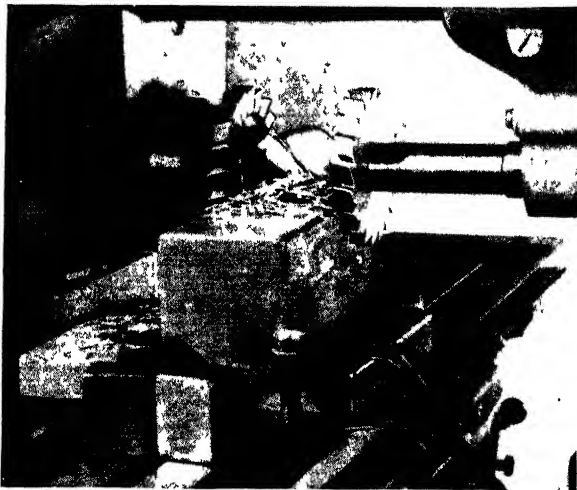


Fig. 8-4. Irregular-shaped castings fastened to table with straps and step block. (*The Brown & Sharpe Manufacturing Company*)

principles, which have been outlined in *Planer Work*, Chapter 2, page 37, should be reviewed and studied for their application to milling work.

**Holding Work in a Vise.** The most commonly used method of holding work on the milling machine is with the vise. Vises are simple to operate and can be quickly adjusted to the size of the work-piece. The operation of clamping work in a vise is one that is fundamental for machine-shop workers. Work can be secured quickly and accurately in a vise and, besides, can be released with a minimum of effort and with maximum speed.

<sup>1</sup> *Rock*: A seesaw movement; up-and-down motion.

Vises used in milling work are designed to hold the work securely and to give rigid support against the pressure of the cutter. The milling-machine vise is designed so that the jaws are kept as near the face of the table as possible, so that the cutting stresses can be withstood more readily.

*Plain Vise* (Fig. 8-5). The plain vise is used for light milling cuts parallel to the length of the work. The bed and the slide are of cast iron, while the jaws are of tool steel, hardened and ground. The vise is fastened to the machine table by means of a screw that passes through the bed and threads into a nut inserted in the table T slot.

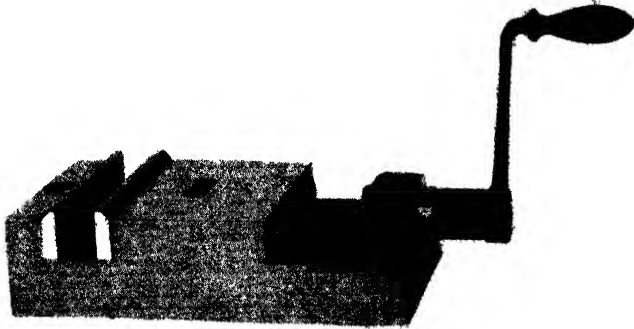


Fig. 8-5. The plain vise. (*The Brown & Sharpe Manufacturing Company*)

The head of the clamping screw fits into a counterbored hole in the vise bed, permitting a free movement of the movable jaw.

*Flanged Vise* (Fig. 8-6). A variation of the plain vise is designed to give greater rigidity because of the addition of a flange all around the base. On each of the four sides a slotted hole is provided to receive the T-slot bolts which fasten the vise to the milling-machine table. The underside of the base is slotted at right angles, and removable keys are provided by means of which the vise may be quickly and accurately aligned, either lengthwise or crosswise, to the table.

The jaws of the vise are made of steel, hardened and ground. They are held in the vise by means of fillister-head screws, and this makes it possible to replace worn or damaged jaws whenever necessary.

*Swivel Vise* (Fig. 8-7). It is frequently of great advantage to be able to mill an angular surface in relation to a straight one without removing the job from the vise. The swivel vise makes it possible to do this. This vise is divided into two sections. The upper, or gripping,

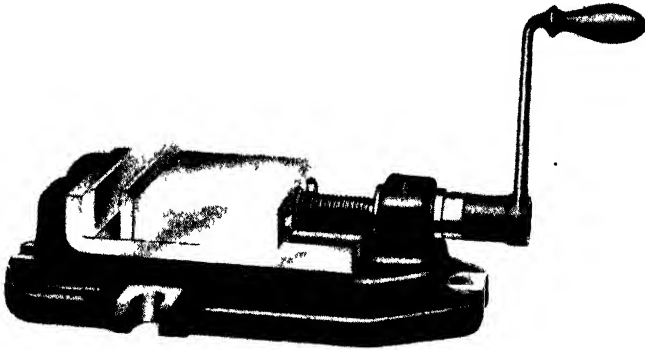


Fig. 8-6. The flanged vise (*The Brown & Sharpe Manufacturing Company*)

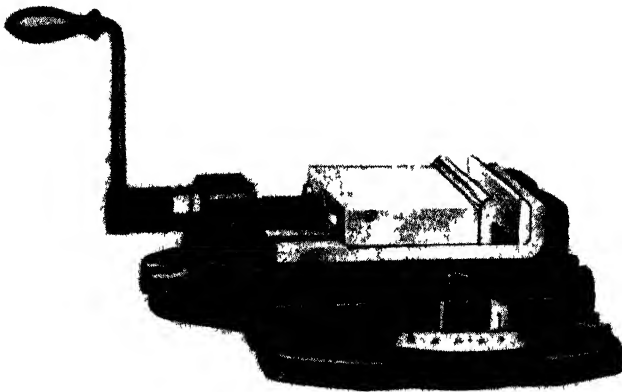


Fig. 8-7. The swivel vise. (*The Brown & Sharpe Manufacturing Company*)

section has the same design as the flanged vise (Fig. 8-6). The lower section, or base, is provided with a central pivot stud and is graduated in degrees. These sections are held together by two bolts, the nuts of which must be loosened to permit the work-holding jaws of

the vise to be swung to any angular position in relation to the cutter or spindle (Fig. 8-8).

*Cam-action Vise* (Fig. 8-9). There are occasions when many duplicate parts are to be milled, and these parts are of size within the clamping range of a vise, and the operation of tightening and releasing a screw-operated vise would prove too time-consuming. The

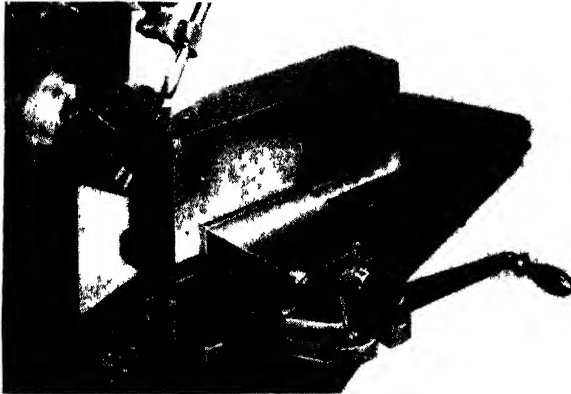


Fig. 8-8. The swivel vise swung to permit job to be cut at an angle to its base. (*The Brown & Sharpe Manufacturing Company*)

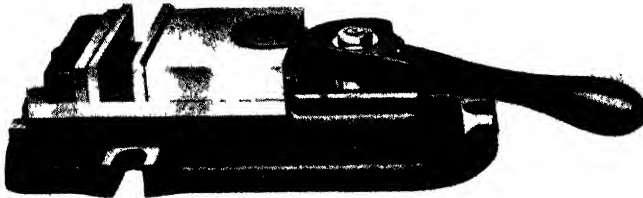


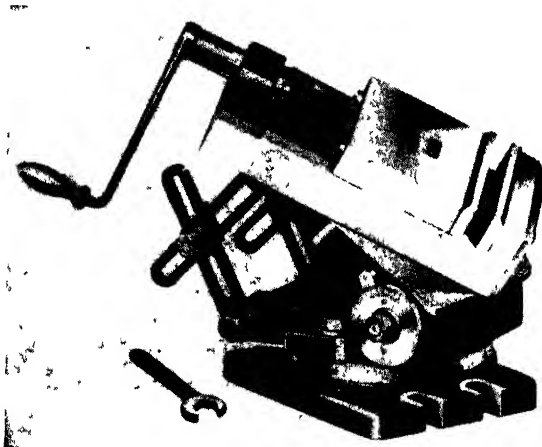
Fig. 8-9. The cam-action vise (*The Brown & Sharpe Manufacturing Company*)

cam-action vise is suitable for such work because a one-movement operation of the cam lever will move the sliding jaw sufficiently for tightening or releasing the work. Loosening the nut on the cam pivot allows the width of the opening between the jaws to be varied to suit the job. The cam pivot acts as a fulcrum for the cam lever and is given greater holding power by being fitted into machined serrations on the upper face of the vise base.



*Toolmakers' Universal Vise* (Fig. 8-10). The limited movement of the table and the comparatively fixed position of the cutting tool of a milling machine makes it necessary to alter the position of the work in order to do the various complicated milling operations found in toolmaking, modelmaking, diemaking, or experimental work.

The universal vise (Fig. 8-10) is designed to fill the need of those who find it necessary to machine work at various angles to precise measurement. The base contains the swivel features of the swivel



**Fig. 8-10.** The toolmakers' universal vise. (*The Brown & Sharpe Manufacturing Company*)

vise and is similarly graduated. There are two sets of slots, which give more convenient facility for clamping on the machine table. The vise, or upper, section is hinged to the base by means of a hinged knee similar to an adjustable angle plate. This permits tilting the vise at any angle, from 0 to 90 deg. The angle of vise from the base is shown on a graduated dial fixed at the hinge pin.

A third, swiveling, movement is provided for the vise section on the upper face of the hinged knee. The vise can be swiveled and tightened at any axis of the hinge. This vise can be utilized to great advantage when suitable angle cutters are not available. There are variations in the design of similarly named vises. Figure 8-11 shows the universal vise being used on an end-mill operation.

**Milling-machine Fixtures.** From the beginning of its development, the milling machine has been closely identified with the mass production of interchangeable machine parts. The two most necessary requirements in modern manufacturing methods are (1) accurate uniformity, and (2) the maximum efficiency of the operations of production. Nonproducing time for machine adjustment and job setup must be kept to a minimum. This has resulted in the development of quick-loading and -unloading work-holding devices that are

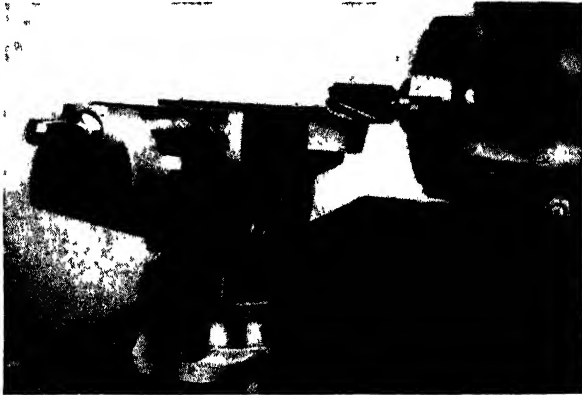


Fig. 8-11. Using the Cincinnati Toolmakers' universal vise to mill the 7-deg. side-rake angle on a single-point turning tool. (*The Cincinnati Milling Machine Company*)

fastened to the table of the machine. These are known as *fixtures* and are commonly used in production milling.

The usual milling-machine fixture is made up of a base and a frame (or body), in which is constructed a "nest" for the workpiece. The job is located accurately by pins and is secured by a clamping device, such as straps, setscrews or cam levers. They must be positioned so as to permit the cutter or cutters free and unhampered access to the surface to be milled, and allow quick placing and removal of the job.

The fixtures must be kept free of chips and dirt, as the presence of foreign material would affect the accuracy of the finished job. A blast from an air hose is the usual method of cleaning fixtures before each loading.

The construction of milling fixtures requires a thorough understanding of mechanical principals and a high degree of trade skill. Fixtures vary in design. The principal aim is to hold the job secure enough to permit the machine and cutter to operate at their maximum efficiency. Fixtures are also made to hold several workpieces

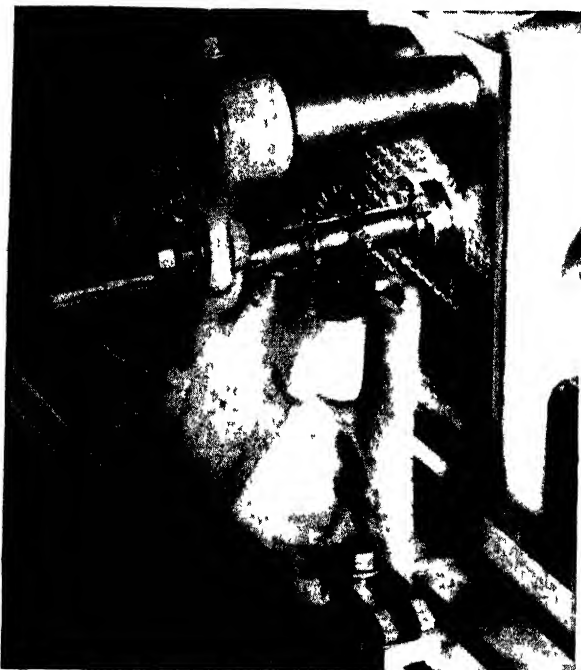
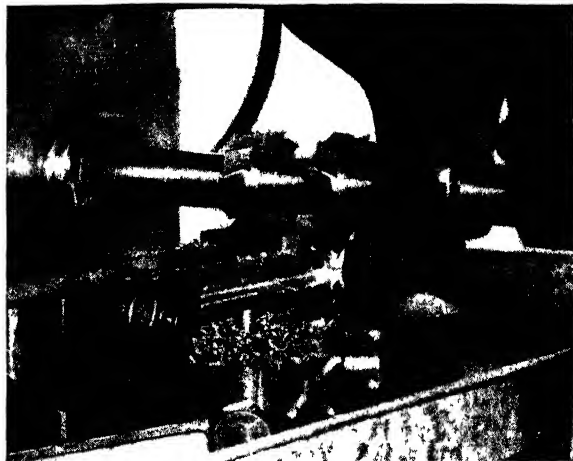


Fig. 8-12. Straddle-milling a casting. (*The Kearney and Trecker Corporation*)

for the same operation. Examples are shown in Figs. 8-12, 8-13, and 8-14.

**Setting up the Milling Machine.** *Accurate Mounting of Work-holding Devices.* There are two important requirements to keep in mind when a job is being mounted for milling: (1) The job must be held securely, giving no opportunity of tool "walk-in" or "chatter." The method selected must hold the work without marring its surface. (2) The work, or the device holding the work, must be aligned accurately with the path of the cutter, both as to its depth of cut and as to the direction in which it is cutting.



**Fig. 8-13.** Machining connecting rods in a fixture (*The Brown & Sharpe Manufacturing Company*)



**Fig. 8-14.** Milling teeth in angular refacing cutters held in a specially made fixture. (*The Brown & Sharpe Manufacturing Company*)

The manufacturers of modern machine tools have gone far toward making machines incapable of inaccuracies. Nevertheless, much still depends upon the skill and judgment of the machine operator and his careful attention to details.

The milling-machine vise is used more often than any other milling attachment. Each time that a vise is clamped onto the machine table, the accuracy of the finished job will depend upon its correct alignment with the center line of the machine spindle. Conditions that contribute toward misalignment are:

1. Alignment keys on the base of the vise may be worn or loose.
2. "T" slots in the table might be worn or damaged.
3. There may be misalignment of graduations on the base of the vise (if it is the swivel type).
4. There may be misalignment of the saddle with the graduations of the base.
5. There may be chips between the surfaces of the table and the base of the vise, or "burrs" and "nicks" on these surfaces.

*Methods of Alignment.* Therefore, whenever accurate results are required from a milling-machine operation, the job or the clamping device in which the job is held must be "trued up," or accurately aligned with the center line of the spindle and the path of the cut.

The best way to set the fixed or solid vise jaw exactly parallel with the cut, or exactly at right angles to it, is by using a dial indicator. This is true for all work-holding devices and for work clamped to the table, the only requirement being a finished surface that can be used as a guide.

First, set the surface to be aligned as near to the correct position as can be judged. Clamp the indicator to the machine arbor or the cutter (Figs. 8-15 and 8-16) just tightly enough to grip securely. The face of the indicator should be convenient for reading. Move the table to bring pressure between the contact point of the indicator and the surface being aligned. Adjust the dial to read zero. Then by moving the table by hand feed right and left in the longitudinal direction, the variation in alignment will be measured by the indicator and the amount recorded by the dial needle. Adjustments can be made accordingly.

If the surface is to be aligned parallel with the arbor, a similar process is followed, the saddle being moved transversely back and

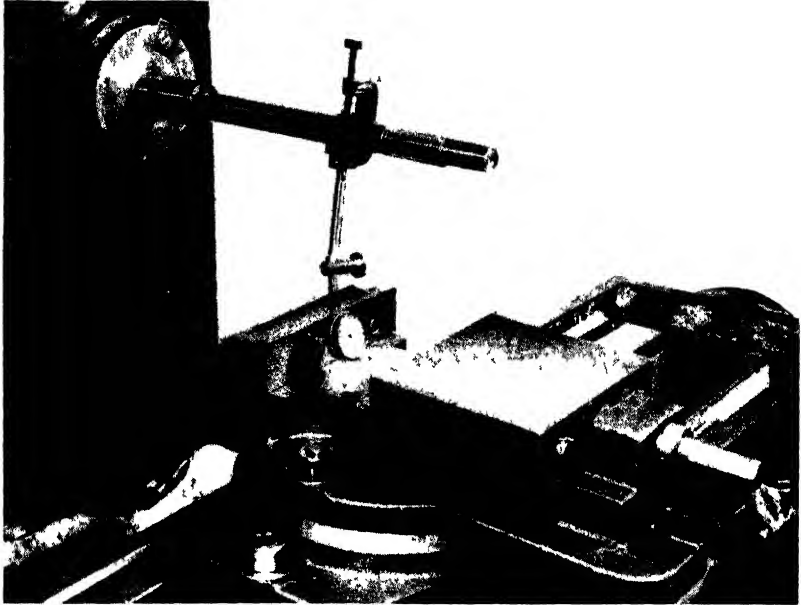


Fig. 8-15. Aligning the solid jaw of the vise parallel with the cut by means of a dial indicator clamped to the machine arbor (James Anderson)

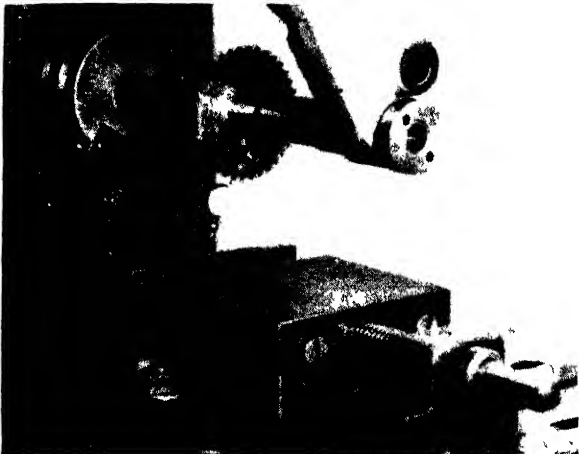
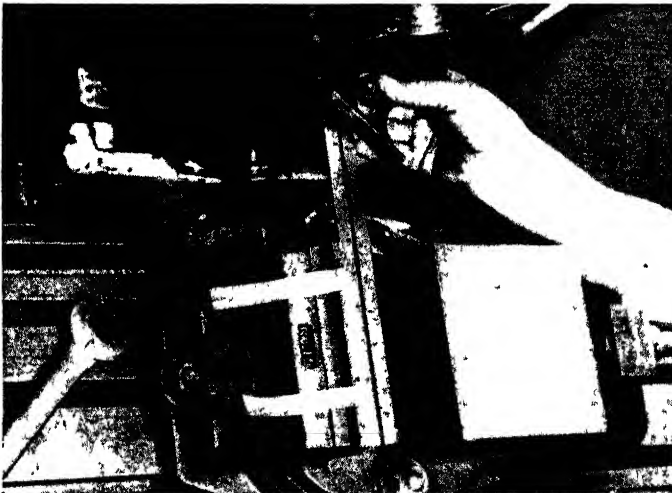


Fig. 8-16. The dial indicator can also be clamped to the milling cutter. (James Anderson)



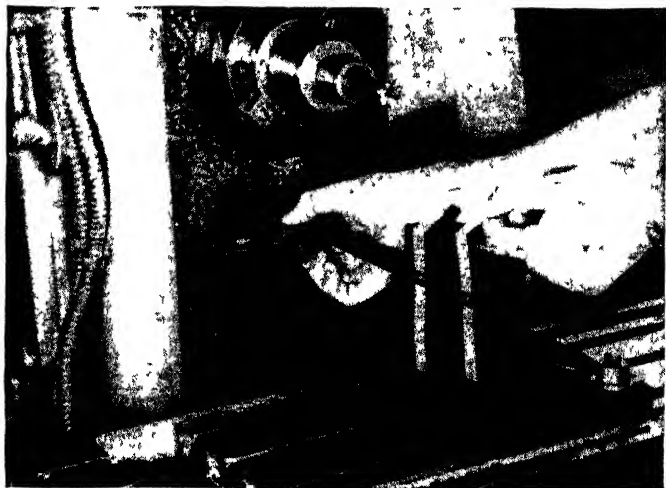
**Fig. 8-17.** Aligning the solid jaw of the vise parallel with the arbor (*James Anderson*)



**Fig. 8-18.** Squaring the solid jaw of the vise with the face of the column, using paper strips as feeler gages. (*James Anderson*)



**Fig. 8-19.** Testing by feeling the pull required to move the paper strip (*James Anderson*)



**Fig. 8-20.** Squaring the face of the angle plate with the face of the column. (*James Anderson*)



forth across the knee (Fig. 8-17). In this manner, either the face of the work, the vise jaw, the angle plate, or the surface most advantageous to align, can be "trued up" to the degree of accuracy measurable by the indicator. Indicators are usually graduated in thou-



**Fig. 8-21.** Truing the face of the angle plate with the center line of the spindle, using a dial indicator (*James Anderson*)

sandths of an inch; but they are also available in graduations of ten-thousandths.

If the job requirements do not call for a high degree of accuracy, a square may be used by placing the beam of the square against the finished face of the column and the blade along the vise jaw or other surface to be squared (Fig. 8-18).

Because feeling can be more accurate than seeing, strips of tissue paper are often placed between the surface to be tested and the blade of the square. If the same force is required to pull both strips, it can be assumed that the surface is square (Fig. 8-19).

The methods outlined for the alignment of the vise can be used for the same purpose and in a similar way when other job-holding devices require accurate positioning on the table of the machine.

Angle plates, accurately machined square and parallel, are often used on a milling machine to support the work. Figure 8-20 and 8-21 show two methods that can be used to assure an accurate mounting of the angle plate on the table of the milling machine.

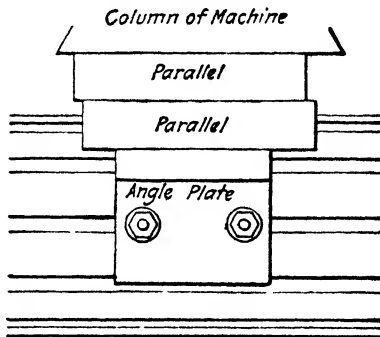


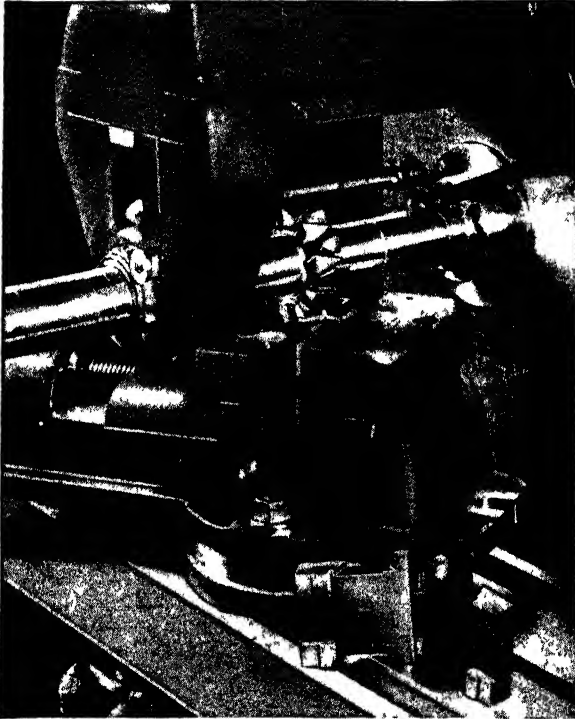
Fig. 8-22. Setting an angle plate parallel with the column face.

Parallels may be used for setting the angle plate fairly tight in its approximate position. Then lightly squeeze one or more clean parallels between it and the face of the column (Fig. 8-22). This will bring the surface of the angle plate in line with the edge of the parallel; then clamp the angle plate securely.

**Special Vise Jaws Used as a Fixture.** Quite often it is possible to utilize the vise as a fixture for holding jobs of unusual shape. This is done by removing the regular vise jaws and substituting jaws that are shaped to the general contour of the job, leaving an allowance to permit the vise to grip the work (Fig. 8-23).

It is not always necessary to remove the regular vise jaws. Whenever the finished dimensions of the job are not too exacting, false jaws, shaped to the contour of the work, can be clamped within the regular vise jaws. This method is commonly used when slots are

milled on the end of round stock, as when the screw-driver slot is being milled in the head of a screw.



**Fig. 8-23.** Simple fixture made by modifying the jaws of a milling-machine swivel vise. (*The Cincinnati Milling Machine Company*)

### PRECAUTIONS TO BE OBSERVED IN SETTING UP THE MACHINE

**Milling-machine Setup.** Fastening the job on the machine, mounting the cutter on the arbor, and adjusting the controls for the speed of the cutter and the amount of feed per minute of the work is known to the machinist as "setting up the job." This part of the job operation calls for careful attention to all the details, each of which is important to the successful completion of the job.

The safety of the machinist doing the job and of those around him

can be endangered by a job carelessly set up or by the flying pieces of a broken cutter that may result from a faulty setup. Excessive speed of the cutter or a too rapid rate of feed can bring about the overheating of the cutter, thus causing it to lose its temper and probably spoiling the job. An incorrect setup is often the cause of broken machines and always ends in nonproductive effort. Such results bring unhappy experiences: a job is spoiled, the tools are broken, the machine is damaged, and the careless worker loses his employment. An experienced machinist makes correct work practices a habit.

Before work on a job is started, it must be analyzed for determining the sequence of operations that will give the required finished product with the minimum number of changes and setups. This information is obtained by a careful reading of the blueprint. As the requirements of the job are noted, a list of the tools needed for completing the job can be prepared. This list will include tools from the machinist's kit and from the tool crib—squares, rules, calipers, indicator, etc., as well as the tools that are kept around the shop—vise, bolts, nuts, washers etc. The small amount of time and effort required for preparing this list will be repaid many times by a saving in repeated visits to the tool crib to obtain a few tools that were forgotten.

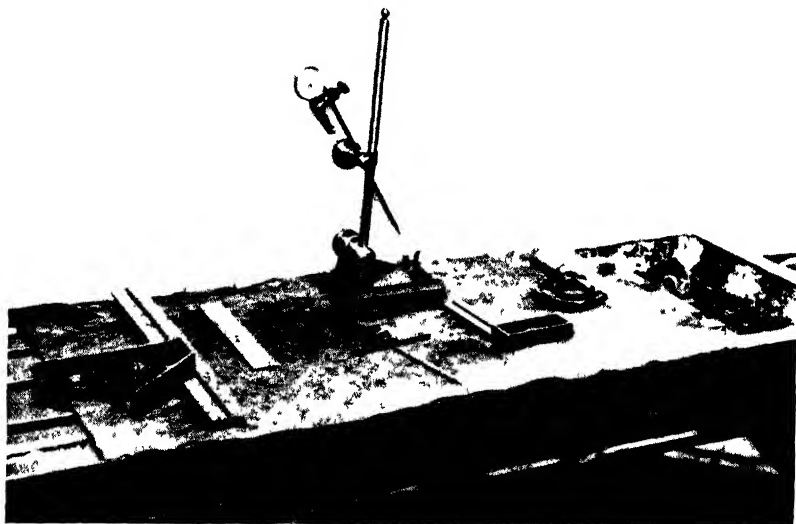
A checkup on the condition of tools to be used for holding the job comes next. Remove burrs and chips from the worktable of the machine and the base of the work-holding device, whether it be a vise or a fixture. A smooth file rubbed lightly over a burr is usually sufficient for removing it. The nuts should turn freely on each bolt and the bolt must slide easily in the T slots of the table. The washers



Fig. 8-24. The bolt on the left is *too* short and the few threads engaged in the nut can easily be stripped. (James Anderson)

used under the nut are important, for a bent or badly scored washer can cause the job setting to be forced out of alignment when the last turn is given to the nut. Bolts should be long enough to permit the engagement of threads for the full length of the nut. A short bolt can result in stripped threads and a subsequent moving of the work. (Figure 8-24 shows an incorrect and a correct bolt length.)

Protect the measuring tools and sharp cutters by placing them on a wiping cloth or on a wooden board (Figs. 8-25 and 8-26).



**Fig. 8-25.** Placing measuring tools carefully on a cloth protects their accuracy and prevents them from sliding off the table (*James Anderson*)

When several pieces are to be machined, arrange them in an orderly way; separate them, placing the unfinished on one side of the machine and the finished on the other. Keep the space around the machine clear. Remove any small pieces of metal lying on the floor and wipe up spilled machine oil. Good housekeeping is one of the habits developed by a good workman as a protection against accidents.

**Setting up the Job.** When all preparations have been completed—blueprint studied, operation sequence determined, tools with-

drawn and placed in a convenient place, clamping device and table made ready, etc., burrs and chips removed, nuts and bolts made free—the actual setup must be made.

The cutting action of the milling cutter is not smooth. Each tooth as it comes into contact with the work creates a small shock,

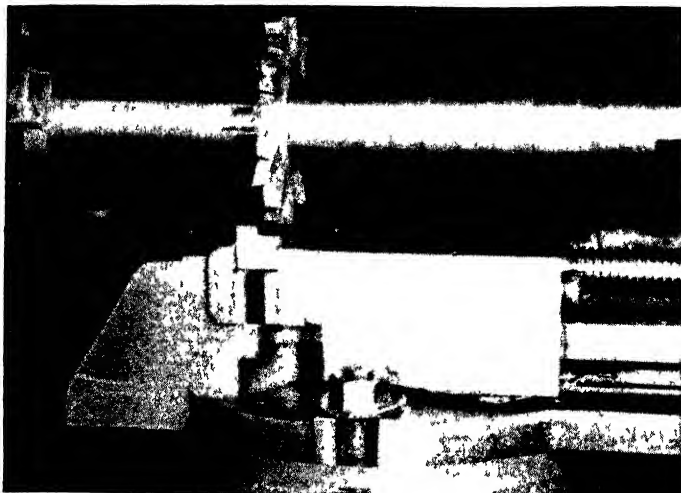


Fig. 8-26. Tools placed on a wooden board to protect the cutting edges and the face of the table. (*The Cincinnati Milling Machine Company*)

so that each revolution of a milling cutter makes a series of these small shocks. If there is the slightest give in the work; if the work is not rigidly supported by the vise jaw or holding device; if the work is not securely clamped in such a way as to make even the slightest move impossible, the repetition of this impact shock will set up

vibrations. Vibrations will result in a quick dulling of the cutting edges of the cutter. Instead of a smoothly machined surface, the cutter will leave an uneven surface of regularly spaced ridges. To avoid vibration, the following precautions must be observed:

1. The job must be clamped securely in the vise or holding device.
2. All possibility of spring must be removed by giving support to the job with shims, jacks, and parallel strips.



**Fig. 8-27.** Work securely held, supported on parallel strips and as close to the column as possible. Cutter mounted on arbor as near the spindle as is practicable. (*James Anderson*)

3. The table should be as close to the column as the job will permit (Fig. 8-27).

4. Mount the cutter onto the arbor as near the spindle as is practicable.

5. Remove burrs and chips from the faces of the spacing collars. A burr on a spacing collar will cause the arbor to bend when the arbor nut is tightened. This will result in a one-sided cutting action where only a few teeth of the cutter will come into contact with the work.

6. Keep the bearing sleeve for the overarm yoke as close to the cutter as is practicable.

7. Lubricate the bearing sleeve and/or the center which supports the outer end of the arbor.

**Selecting the Cutter.** Get the cutter that is of the right size and shape and be sure it is sharp. Never use a dull cutter. Considerable time may be wasted by using a cutter that is larger in diameter than is necessary. Referring to Fig. 8-28, suppose it is required to finish the surface *X*; the proper cutter to use is an end mill of about the diameter of *A*. In the figure, *B* shows the diameter of the smallest plain milling cutter that can be used and allow the arbor and collars to pass over the work, and *C* represents a cutter much larger than

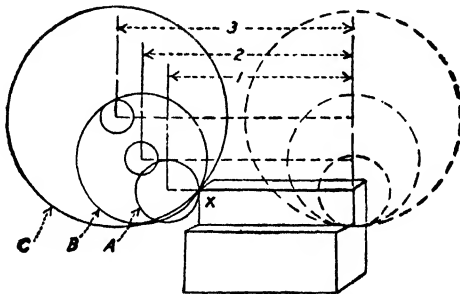


Fig. 8-28. A comparison of feeding distances required with small- and large-diameter cutters.

necessary. By comparing the feeding distances 1, 2, and 3 it will be apparent that the cutter of smaller diameter will takes less time.

#### HOW TO MOUNT A MILLING CUTTER ON A MILLING MACHINE

1. Clean chips and oil from tapered hole in the machine spindle.
2. Clean tapered shank of arbor; remove burrs with a smooth file or oilstone.
3. Insert and tighten draw-in bolt when arbor shank has steep taper. Drive arbor home with a Babbitt or a lead hammer when the shank has Brown & Sharpe No. 10 tapered shank.
4. Clean arbor and collars. Burrs on the face of the spacing collars will cause the arbor to bend when the arbor nut is tightened.
5. Mount cutter on the arbor as close to the spindle as practicable. The thread on the arbor will determine the cutting direction of



the cutter teeth. The resistance to the cutting action of the teeth could tend toward tightening the arbor nut.

*NOTE:* Cover the cutter with a cloth while it is being handled. This is a safe practice that will prevent accidents.

6. Tighten the arbor nut *handtight*, sufficient to grip collars and cutter firmly together.

*NOTE:* Do not tighten the nut with a wrench at this time. Being unsupported, the arbor can be easily bent.

7. Loosen the arm-clamp lever and push out the overarms far enough from the face of the column to allow for the placing of the arbor yoke. Lock it in this position.
8. Wipe off all fitting or contacting surfaces on arm, yoke, and arbor-bearing sleeve. Apply a thin film of oil to each surface.
9. Slide arbor yoke into position and tighten it to the arm.
10. With power shut off, engage the back gears to lock the spindle. This is done by setting the speed controls at the lowest speed.
11. Tighten the arbor nut. Use a wrench that fits the nut snugly. Disengage the back gears to free spindle.

*NOTE:* It is unnecessary to use a hammer on the wrench. The wrench is designed to give leverage sufficient to tighten the nut adequately.

12. Before operating the machine, clear the machine table of all the tools used in making the setup. Tools left on the machine may get jammed between cutter and job or between table and column.

No mention has been made in the above setup of keying the cutter to the arbor. Milling-machine arbors have a keyway running the full length. Cutters also have a keyway. When the cutter is keyed to the arbor, slippage is impossible. In production milling, the cutter or cutters and the arbor are keyed together. There are occasions when slippage would be preferable: Frictional pressure between the nut, spacing collars, and the cutter gives sufficient torque to the cutter and, under normal conditions, there will be no slippage.

If an end mill is to be used, it will be necessary to clean the mating surfaces and to drive the tapered shank of the end mill into the

spindle. The teeth of the end mill are easily chipped and broken off. Use a hardwood block between the teeth and the hammer when driving the cutter home (Fig. 8-29). Tooth breakage is commonly caused by lead or Babbitt hammers being applied directly to the teeth of an end mill, and should be avoided (Fig. 8-30).

**Setting the Speed and Feed.** Once the job has been bolted and clamped to the table and the cutter selected and mounted, it then



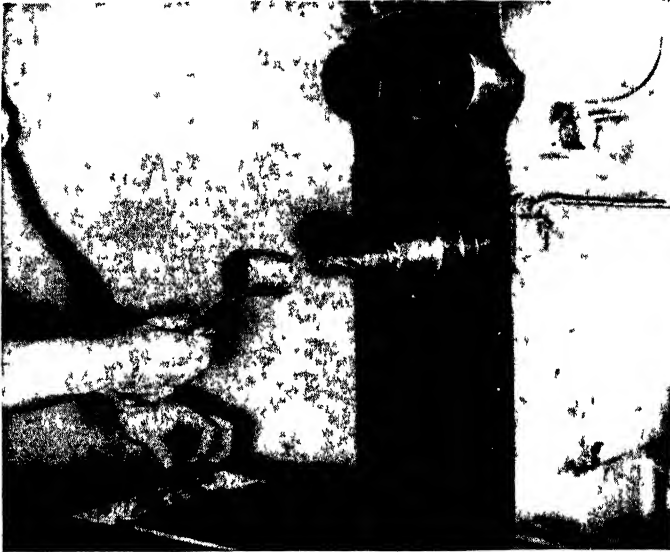
**Fig. 8-29.** Driving an end mill with a hammer and a block of hardwood. (*James Anderson*)

becomes necessary to calculate the proper r.p.m. of the cutter and to determine the correct feed of the work to the cutter.

To select the proper r.p.m. it is necessary to know the cutting speed (so many feet per minute) of the material to be cut and the diameter of the cutter to be used. Although the cutting speed of each metal is easily ascertained, either from handbook or local distributor, there are other factors that can influence the acceptance of that number: for instance, the shape of the job and whether it can be held rigidly while it is being cut; the sharpness and shape of the cutter teeth, and the age, type, and condition of the machine on which the

job is being machined. These factors, and others, will also influence the amount of the work feed rate or *feed*.

The amount of stock to be removed, per cut, will be an important factor, as will the type and quality of the desired finish. The general tendency is to set the feed much slower than capacity



**Fig. 8-30.** A common cause of broken cutters driving an end mill home with a lead hammer (*James Anderson*)

Wherever possible, finish the job in one cut. Two cuts, roughing and finishing, are necessary only under the following conditions:

1. When a considerable amount of metal must be removed
2. When the job has a tendency to spring away from the cutter and cannot be sufficiently supported.
3. When requirements call for a particularly accurate result or an excellent finish.

**Setting the Feed Trip.** When several pieces are to be milled and any of the automatic feeds are used, the feed-trip dog is set to operate at the desired point, usually as soon as the cutter clears the work at the finish of the cut.

The feed-trip dog is a valuable aid to the milling-machine operator who is dividing his attention between two or more machines. Once

the dog is set, the travel of the table will stop as soon as the cutter has passed over the job or traveled along the job to the required measurement.

**Use of the Positive Stop.** Whenever it is necessary to use the hand feed and the requirements of the job call for the cut to start or stop at a certain specified point, the positive stop must be set. An example of this would be the milling of the flutes of a tap or reamer, where the cut ends in the metal and where the end of each cut must coincide with its neighbor in position and finish (Fig. 8-31).



Fig. 8-31. Cutting the flutes of a helical taper reamer. The positive and adjustable feed-stop dogs are set in the required positions. (*The Cincinnati Milling Machine Company*)

Whenever it is necessary to start the cut by raising the table so that the revolving cutter cuts into the work, there is a danger of pulling the work into the cutter. The cause for this lies in the amount of backlash between the threads of the feed screw and the feed-screw nut. The positive stop can prevent the table from being pulled in the direction of the cutter.

**Unwanted Undercut.** It is advisable not to stop the automatic table feed and still permit the cutter to revolve. This will always result in a slightly deeper cut at that point. While this may prove insignificant on a roughing cut, it is disastrous on a finishing cut. Such an undercut will be more pronounced if the cutter or the arbor runs out of true.

If it becomes absolutely necessary to stop while making the finishing cut, *stop* the cutter (and the machine), but do not disengage the automatic feed. It is always advisable to stop the machine before running the table back to the starting position. If this is not done, a series of chatter marks will result.

### EXAMPLES OF PLAIN MILLING OPERATIONS

**Milling a Rectangular Piece.** One of the most common jobs on a milling machine is squaring the sides of a rectangular block, as illustrated in Fig. 8-32.

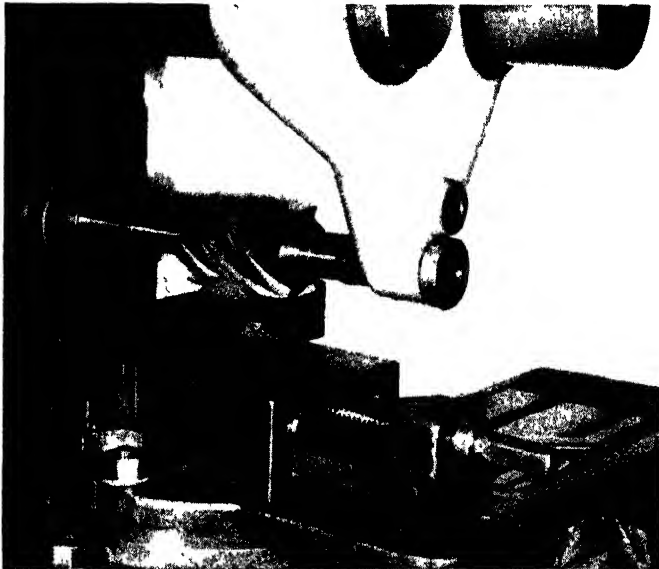


Fig. 8-32. Milling the sides of a rectangular block of cast iron. (*James Anderson*)

#### ***SQUARING THE SIDES OF A RECTANGULAR BLOCK***

1. The cutter selected should be wide enough to cover the broadest surface to be milled. A helical slab mill will give best results. Select parallels of the proper height, so that the work does not project too far above the jaws. Tighten the work securely in the vise, then tap with a hammer to make sure that the block is

firmly seated on the parallels. It is not necessary to use a Babbitt hammer except when a very shallow or sectionial cut is to be taken. Under normal circumstances any marks that a hammer will make on the surface of the job will be removed with the first cut. Narrow strips of tissue paper placed on the top surface of the parallel strips will act as a feeler gage and will show if and when the job is firmly seated on the parallels.

2. Set the speed-change levers for the correct spindle feed.
3. Set the feed levers for the correct feed per minute.
4. Bring the work under the cutter and, by using a strip of paper as a feeler gage, bring the table up until the cutter touches the work. Set the knee-elevating shaft dial to zero.
5. Move the work clear of the cutter, raise the table, to give the correct depth of first cut. Lock the knee to the column.
6. Set the cutter revolving and move the table until the cutter touches the job.
7. Move the work on to the cutter for  $\frac{1}{4}$ -in. long by hand feed. This will serve as a trial cut.
8. Stop the machine and bring the work clear of the cutter.
9. Measure the finished surface, to see if the size is suitable and the cut is parallel. This can be measured with calipers or micrometer.
10. Make whatever adjustment is shown to be needed.
11. Move the work to the cutter and engage the automatic table feed. Use necessary cutting lubricant.
12. Stop the machine at the end of the cut and move the table back to the starting position.
13. Remove the chips from the job and from the vise with a brush. *Brush chips into a small shovel instead of onto the floor. This is a part of good housekeeping.*
14. Remove the work from the vise; clean the vise and the parallels. Use a brush and a lintless cloth hand wiper.
15. Remove sharp corners and burrs from the job with a single-cut file.
16. Check the job with rule and straightedge.
17. Replace the job in the vise with the finished side against the solid jaw.
18. Place a piece of round cold-rolled steel between the movable vise jaw and the work. The round stock should be set almost halfway

down the depth that the job is set in the vise (Fig. 8-33). The round stock forces the finished side *flat* against the solid jaw of the vise and eliminates the possibility of the block's shifting in the vise.

19. Start the machine and bring the work to the cutter. Engage the feed and make test and full cut as on the previous side.

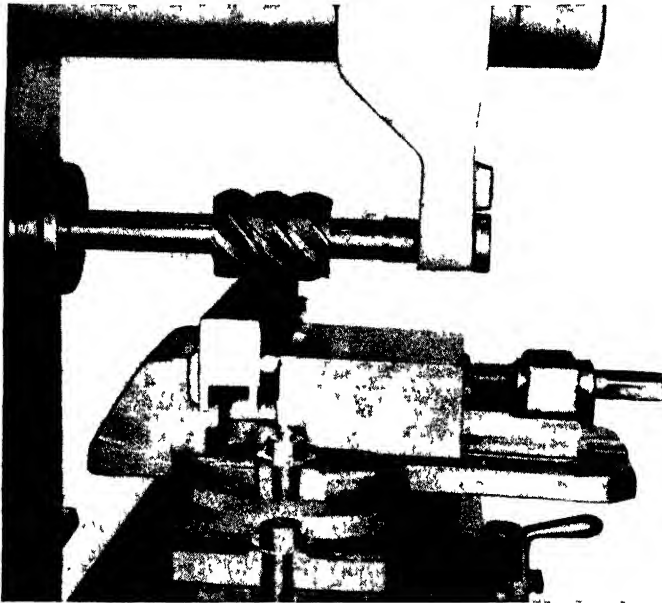


Fig. 8-33. Cutting the second side of the rectangular block (James Anderson)

20. Clean job, vise, parallels, and table as before and place the job in the vise with the finished sides resting against the solid vise jaw and on the face of the parallels.
21. Use round stock and proceed as outlined for the second surface. Check sizes after  $\frac{1}{4}$ -in. trial cut, with calipers or micrometer, depending on the required accuracy on the job. It will not be necessary to use round stock when milling the fourth and last side. The work should rest squarely against the solid jaw and parallel and square on the surface of the parallel strips. Here, too, a strip of tissue paper between each parallel and the job will give accurate indication of the job's lying square.

**Squaring the Ends.** The ends of a job are best squared by laying the work flat and allowing it to project from the vise or other holding setup and finishing with either an end-mill or a side-milling cutter, large enough to reach the necessary distance.

If the work is long enough to project a short distance from both ends of the holding device, vise or fixture, and if it is required in sufficient quantity, a pair of side-milling cutters can be spaced the correct distance apart with accurately measured spacing collars and both ends can be milled in one operation.

**Boring and Drilling.** There are times when the milling machine has to be utilized for machine-shop operations other than milling.

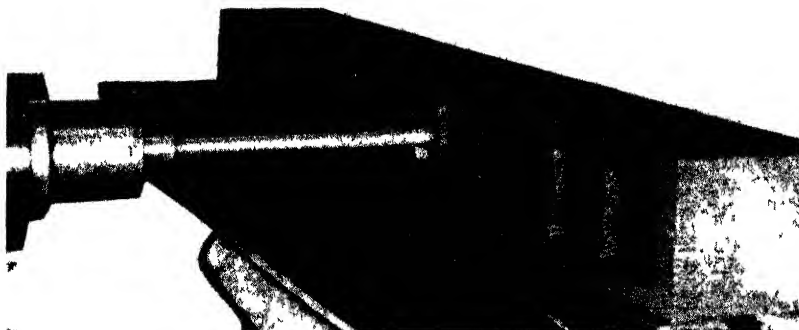


Fig. 8-34. Boring holes on accurately spaced centers. (*James Anderson*)

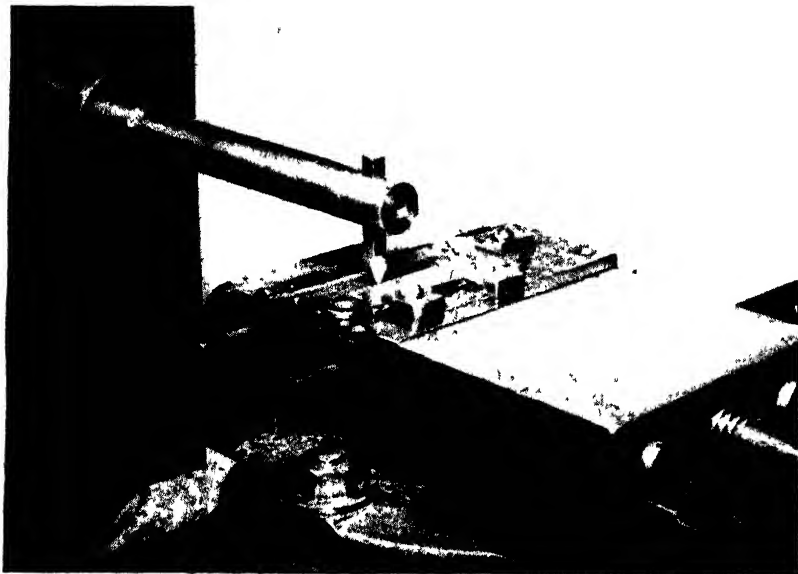
Because of the accuracy with which the table can be used in a longitudinal movement, the miller is well adapted for drilling and boring holes in specified pitch centers (Fig. 8-34). The drill chuck or boring bar can be inserted into the spindle and the holes can be bored on centers accurately spaced, not only horizontally, but also vertically.

**Simple Graduating.** The boring bar, when mounted in the spindle of the milling machine, can be utilized to indent the graduations in rules and squares. A sharp-pointed tool held stationary cuts the lines as the work is fed onto it by a hand-fed movement of the table (Fig. 8-35).

The longitudinal movement of the table, measured by the graduated dial of the table screw, can be measured to a thousandth-of-an-inch accuracy, assuming that the threads of the table screw are not badly worn.



**Face Milling** (see Fig. 8-36). Finishing a surface at right angles to the axis of the cutter is known as *face milling*. This does not mean that end teeth or side teeth do the cutting. As a matter of fact, the teeth on the periphery do all or nearly all of the cutting when "facing" is done by an end mill or a face mill or a side mill. The action of the teeth on the end (or side) when they are properly sharpened



**Fig. 8-35.** Method used to graduate a drill gage. (*James Anderson*)

is a slight scraping or finishing cut. If these teeth are dull or improperly ground, the surface produced will be rough and probably be gouged here and there.

During face milling, care must be taken to have the cutter securely in place, and also to make sure that there is no end play in the machine spindle.

If it is desired to finish a curved surface of the same radius as the cutter, this may be done by feeding parallel to the axis of the cutter. In this case, the end teeth do the cutting and the peripheral teeth do the finishing.

**Cutting a Keyway or Similar Groove.** There are several different milling-machine methods of cutting a keyway in a shaft, namely,

with a plain milling cutter, with an end mill, with a crotter mill, with a Woodruff cutter. Also there are several ways of holding the shaft—in a vise, in V blocks, clamped to the table itself, or between the index centers or in the index-head chuck. In any case, care must be taken to make the keyway parallel to the axis of the shaft.



Fig. 8-36. Face-milling work held in a toolmakers' vise. (*The Cincinnati Milling Machine Company*)

Arrange the worktable and the work as close to the column as practicable. The next step is to place the cutter in position. If it is a taper-shank cutter, place it in a suitable collet and drive home, carefully, with a wooden block against the end. If a Woodruff cutter (Fig. 8-40) is used, be very sure that it is firmly held in its chuck spring collet. If a slotting cutter mounted on an arbor is to be used, place it on the arbor in approximately the correct position over the work.

Assuming that a cutter of the correct width is used, the work must be adjusted until the cutter is central. This is usually called "locating the cutter central," but as a matter of fact it is the work that is located.

**Locating the Cutter Central.** One method is shown in Fig. 8-37. Feed the work carefully toward the revolving cutter until the cutter just tears a piece of tissue paper *A*. Then lower the table and feed in the previously calculated distance *D*, using the graduations on the feed screw. If extreme accuracy is desired, check the distance

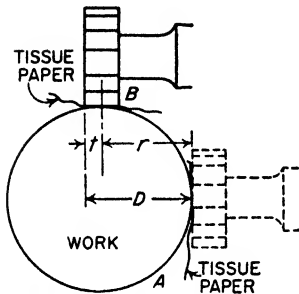


Fig. 8-37. The distance *D* equals one-half the thickness *t* of the cutter plus the radius *r* of the work.

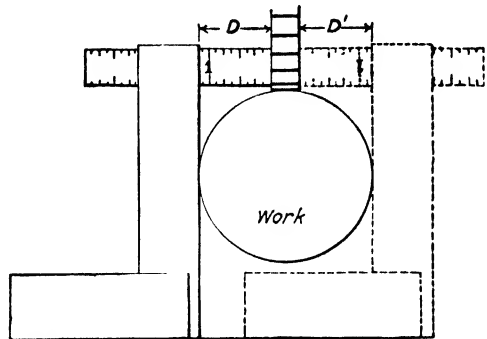


Fig. 8-38. The distance *D* equals the radius of the work minus one-half the thickness of the cutter.

and, in any event, *beware of the backlash*. If the keyway is to be cut with an end mill or cotter mill get peripheral contact first as in *B*, Fig. 8-37, then adjust the work an amount equal to the radius of the work plus the radius of the cutter.

A method which may be used if side or end contact is inconvenient (as happens sometimes with a slotting cutter) is shown in Fig. 8-38. Place a square against the shaft and measure the calculated distance *D* or, as many prefer to do, move the work until the measurement of *D* and *D'* are equal. The cutter must *not* be revolving.

Still another method that is much used and is fairly accurate is illustrated in Fig. 8-39. Adjust the work approximately centrally under the cutter and raise the table until a piece of paper is torn between the revolving cutter and the work, then raise it four or five

thousandths more, allowing a small "spot" to be cut. Stop the cutter, lower the table and run back a short distance. The small oval "spot" now clearly seen is exactly over the axis of the shaft and the table must be adjusted until the spot appears midway between the sides of the cutter.

**Adjusting for Depth of Cut.** When it is desired to make a cut a certain depth (or at a certain distance from a given surface), the work is carefully fed by hand in the necessary direction until a piece of paper held against the given surface is torn by the revolving cutter. (*Use a long piece of paper; keep your fingers away from the revolving cutter.*) This is the starting point for the final adjustment and it is a good plan to set the graduated collar at zero. Then move the work the distance required. The contact position when setting up for cutting the keyway (Fig. 8-37) is shown at  $B$ .<sup>2</sup>

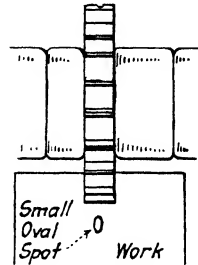


Fig. 8-39. Setting the cutter central by the small oval spot. The view is looking down toward the tailstock.

It makes no particular difference whether the surface to be gaged from is curved or flat, vertical or horizontal, the above suggestions will apply.

**Woodruff Keys.** A line of keys of standard sizes with cutters to correspond which is much used in machine construction is known as the *Woodruff*.

The keys, Fig. 8-40(a), are denoted by a number or letter, as the case may be, and the corresponding cutter (b) will cut a groove into which the key will fit properly. Frequently a series of two or more keys is used, as shown in (d).

Cutters are furnished either right hand or left hand as desired. For sizes of cutters and keys see Table 7, page 695.

<sup>2</sup> It should be remembered that the depth of keyways and similar grooves is measured from the edge of the slot and consequently the work must be raised a certain amount after it touches the cutter before beginning to cut the prescribed depth of the keyway. Table 8 gives the various amounts to raise the work for sizes of shafts up to  $2\frac{1}{4}$  in. in diameter. For larger sizes consult F. H. Colvin and F. A. Stanley, *American Machinist's Handbook*, 8th ed., McGraw-Hill Book Company, Inc., New York, 1945. For ordinary work, scale measurement from the edge of the keyway is satisfactory.

When setting up, adjust the machine table crosswise until the cutter is central over the shaft, Fig. 8-40(c). Scribe a line (on the first piece) indicating the middle of the key position  $d$ , and run the work under the cutter until the line is under the axis of the cutter. Then raise the table to cut the groove to the correct depth, using plenty of cutting compound. It is customary to cut the keyseat to such a depth that the key will project one-half its thickness above the shaft. When the correct position of cutter and depth of cut has been determined, set the graduations at zero; if a hand-milling machine is used, set the positive stops.

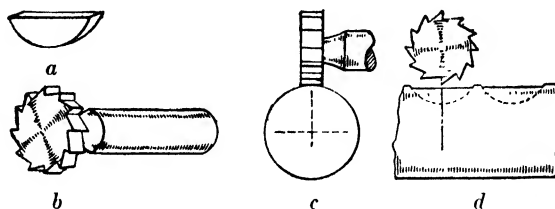


Fig. 8-40. (a) Woodruff key; (b) cutter; (c) end view of setup; (d) side view of setup.

Succeeding pieces should be located lengthwise by a suitable stop or otherwise to bring the key into the same relative position on each piece.

### QUESTIONS ON TYPICAL MILLING SETUPS AND SIMPLE OPERATIONS

1. Name the two most versatile machines in the metalworking industry.
2. Explain the use of the T slots in the milling-machine table.
3. What type of work requires the use of shims and wedges?
4. Name five types of vises used in milling-machine practice and explain their differences.
5. Give the uses of milling-machine fixtures.
6. What method is used to locate the job in a fixture?
7. Why is it necessary to clean the fixture before each loading?
8. Why is the milling-machine vise used more often than any other milling attachment?
9. Give three factors contributing to the misalignment of the milling-machine vise on the table.

10. Explain the method of aligning the vise jaw parallel with the cut using the dial indicator.
11. Explain the method of squaring the vise jaw at right angles to the cut using the dial indicator.
12. To what degree of accuracy can the milling-machine vise be aligned?
13. State two other methods of aligning the vise.
14. Explain how the vise can be used as a fixture on jobs of irregular shapes.
15. Give three hazards endangering the safety of the operator.
16. How should the machinist care for his tools when making milling-machine setups?
17. Explain the cutting action of a milling-machine cutter.
18. When would it be most practical to use a cemented-carbide cutter?
19. State reasons for using cutting fluids.
20. What is the correct method of securing an end mill in the machine spindle?
21. Explain what is meant by speed and feed.
22. When is it practical to use the positive stop?
23. Name three operations other than milling for which the milling machine can be used.
24. What type of milling cutter is used to mill keyways?

## The Index Head and Indexing Operations

Indexing may be defined as the process of causing the work to be moved any desired amount on its axis.

In the construction of modern machines, there are many parts that are round or circular in shape and that have slots, teeth, or spaces cut across their peripheral faces. A common example is the spur gear, or the roller chain sprocket. The basic requirement of such machine parts is that the distance from one slot, tooth, or space to the next is the precise amount required for its functioning. Each tooth of a gear or sprocket is the same size and shape as its neighbor and they are spaced exactly the same distance apart. This exact spacing is accomplished by means of a machine operation called *indexing*. Many methods of indexing are in use in modern machine manufacture. Mass production of machine parts requires the service of quick indexing attachments to speed job operations. In order to make this possible, indexing mechanisms are developed for the machining of single parts. None of them can be used for any other part that is of different shape or that is divided into a different number of parts (see Fig. 9-1).

**Index Head.** The attachment called the *index head* was originally developed for use on the milling machine. Its use has been extended to cover shaping and planing operations. The index head, or as it is commonly called by machinists, the *dividing head*, is nearly always used in conjunction with a *footstock*, often called a *tailstock*. Together they are known as *index centers*.

Of the several types of index centers, the simplest is called the *plain index head* (Fig. 9-2). The plain, or direct, index head is used for work of average accuracy. The index crank is connected directly to the headstock spindle and the crank and the spindle rotate as a

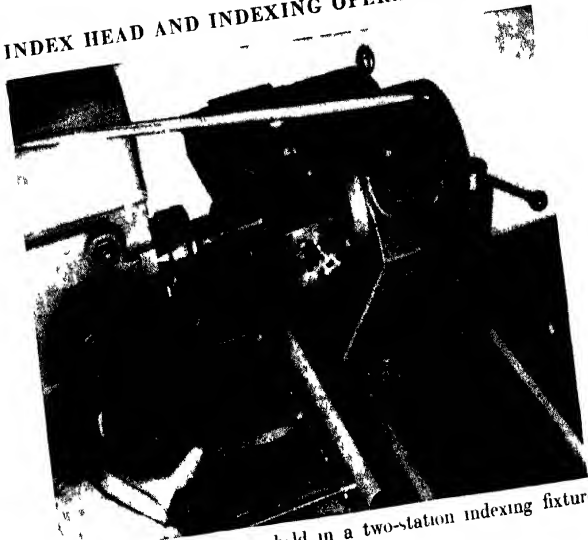


Fig. 9-1. Boring-pump bodies held in a two-station indexing fixture (The Cincinnati Milling Machine Company)

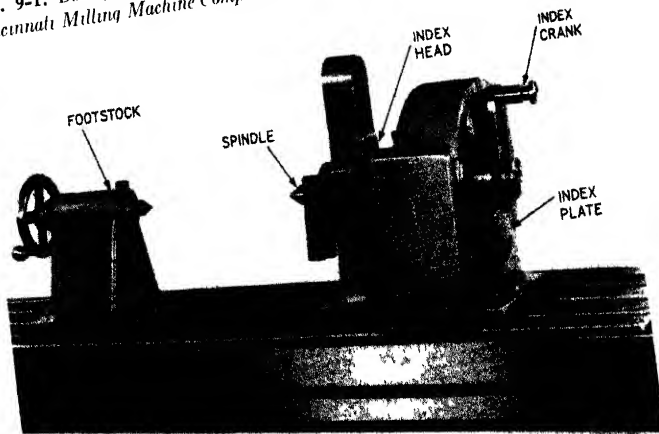
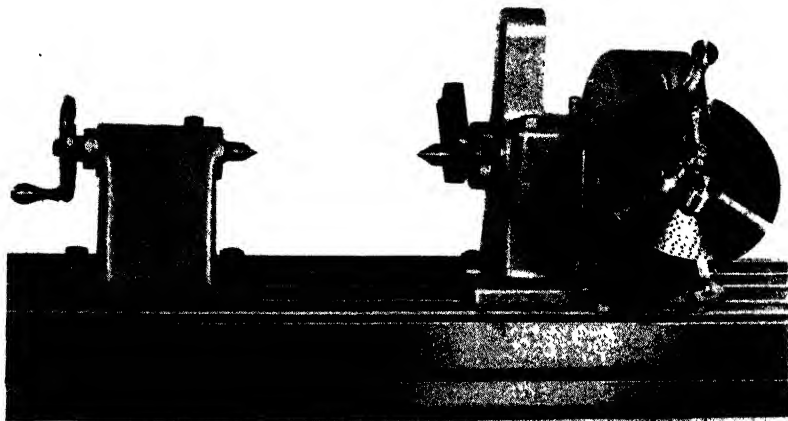


Fig. 9-2. The plain or direct index head, sometimes used when handling a large amount of work which requires indexing on jobs where great accuracy is unnecessary (The Cincinnati Milling Machine Company)



unit. This is known as *direct indexing*, and the number of divisions will be limited to the number of holes in the index plate; the maximum number possible is 50.

**Gear-cutting Attachment** (Fig. 9-3). The gear-cutting attachment is used for spur-gear cutting and similar work requiring a higher degree of accuracy and numbers above 50. Indexing on this type of index head is accomplished through a worm and a worm gear having a 40 to 1 ratio (to be described in a later section). All numbers



**Fig. 9-3.** The gear-cutting attachment is used for spur-gear cutting and similar work. (*The Cincinnati Milling Machine Company*)

up to and including 60, and all even numbers and those divisible by 5 from 60 to 120 can be indexed with this attachment.

**Spiral Milling Head** (Fig. 9-4). This attachment is similar in all particulars to the gear-cutting attachment, except for the addition of the driving bracket by which the headstock is connected, by gearing, to the lead screw of the milling machine. This arrangement makes it possible to cut helical gears, flutes in drills and milling cutters.

**Universal Spiral Index Head** (Fig. 9-5). This head is the one most likely to be found in the majority of machine shops. As its name implies, this type of index head can be used to execute all forms of indexing. It is not only versatile but accurate. Work can be supported between centers or held in a chuck. It is possible, through

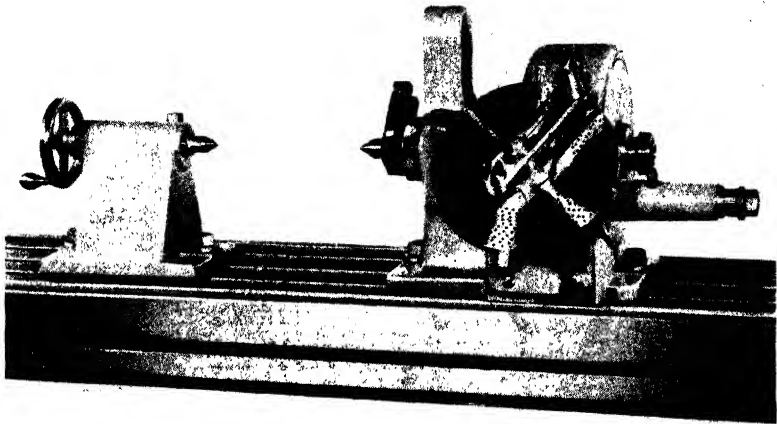


Fig. 9-4. The spiral-milling head. (*The Cincinnati Milling Machine Company*)

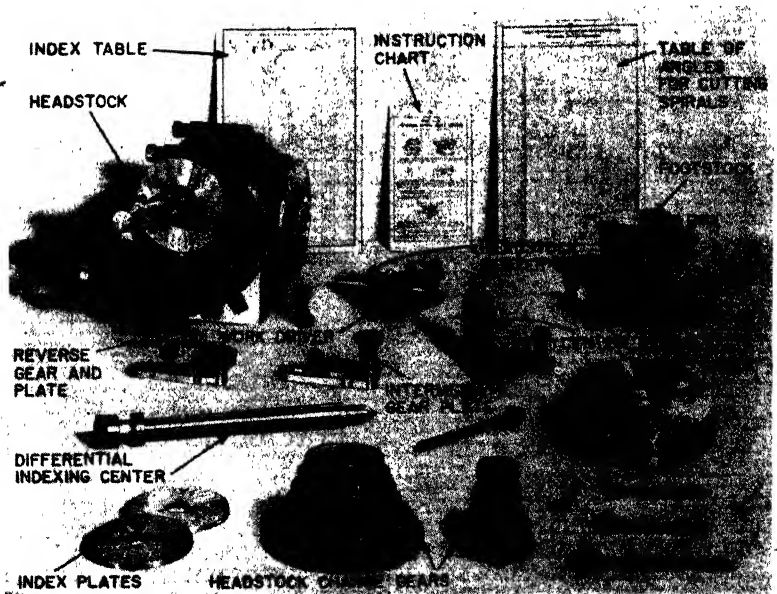
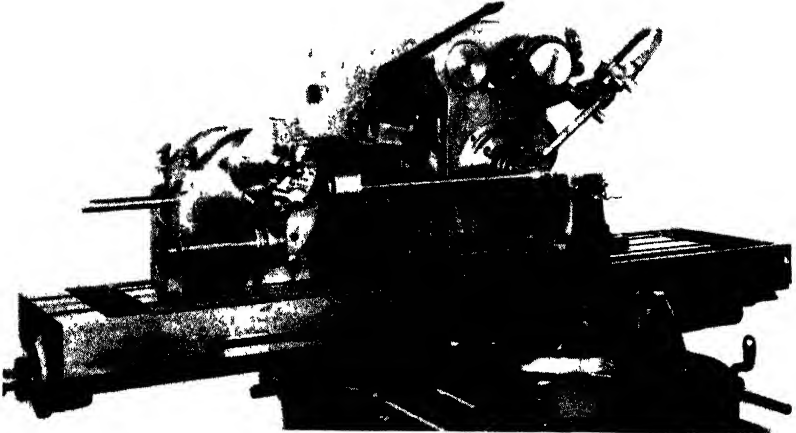


Fig. 9-5. The universal spiral-index centers with full equipment. (*The Brown & Sharpe Manufacturing Company*)

a train of selected gears, to index and rotate work in conjunction with the movement of the table.

The practice of several manufacturers is to arrange the index centers on the milling-machine table with the head at the left (Fig.



**Fig. 9-6.** The Brown & Sharpe index centers. The head is on the left end of the table. (*The Brown & Sharpe Manufacturing Company*)



**Fig. 9-7.** The Cincinnati index centers. The head is on the right end of the table. (*The Cincinnati Milling Machine Company*)

9-6), while other manufacturers design the head to be used at the right end of the table (Fig. 9-7).

**Headstock.** Although there are differences in the design and construction of index heads, the principle of their operation is basically

the same. The headstock (Figs. 9-8 and 9-9) contains the work spindle and the mechanism for obtaining a rotary movement of the spindle when required.

The *work spindle* is provided with a taper hole to receive the live center or the taper shank of other tools, special arbors, or work-holding tools. The nose of the spindle is threaded to hold a chuck. The spindle has a large bearing surface accurately fitted and, in addition, a clamping device to give greater accuracy and rigidity under a heavy cut. The spindle is carried in the *swiveling block*, which is arranged between housings cast as an integral part of the base plate. The swiveling block is constructed so that it may be tilted until the spindle is in any desired position,

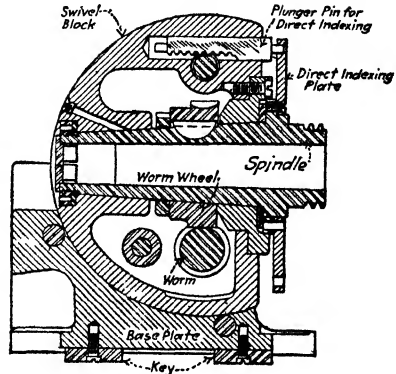


Fig. 9-8. The vertical section of a Brown & Sharpe index head.

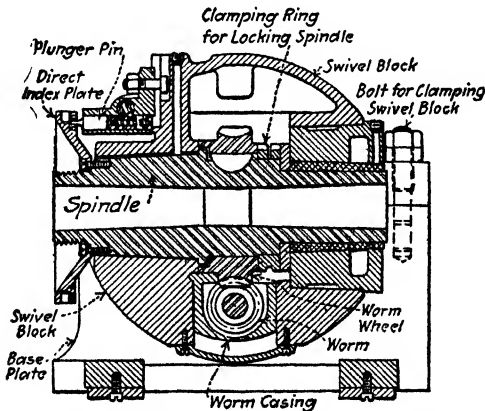


Fig. 9-9. The vertical section of a Cincinnati index head.

from 5 deg. below the horizontal to 10 deg. beyond the perpendicular, and then be clamped rigidly to the base.

Graduations on the side of the head indicate the angle of elevation to half degrees. The alignment of the head with the table longi-

tudinally is provided by means of two aligning tongues on the underside of the base plate, which fit a T slot in the table.

Descriptions of other parts of the index head are given when the mechanical functions are discussed.

*Footstock* (Fig. 9-10a). The footstock is used for supporting the outer end of pieces being milled. Primarily, it is for work held on centers, but it is also used to support the end of work held in a chuck.

The footstock center may be adjusted longitudinally and, in addition, the block which holds the center and its adjusting screw may be moved vertically. It can also be tilted out of parallel with

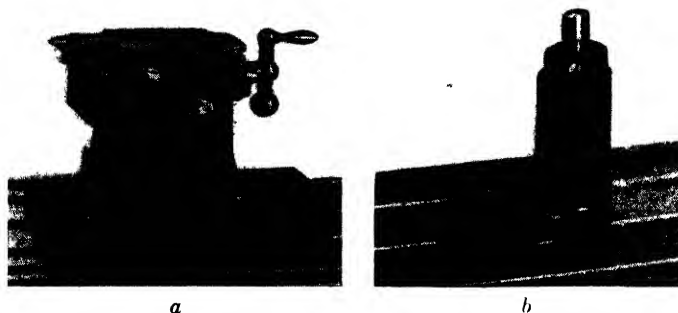


Fig. 9-10. The footstock, *a*, the adjustable center rest, *b* (*The Brown & Sharpe Manufacturing Company*)

the base, in order that it can be kept in alignment with the headstock center when the head is tilted for milling tapered work.

The adjustable center rest (Fig. 9-10b) is included with the universal spiral-index centers and is used to support long, slender work held between centers. It is adjustable and can be locked in position.

**Methods of Indexing.** The primary purpose of the mechanism of the index head is the exact division of a circle, or a part of a circle, into a specified number of parts. It is also possible to index for angular distances.

There are several methods of indexing, namely, *direct*, *simple*, *compound*, and *differential*. Of these methods, the direct and the simple are those most commonly in use. Compound indexing, which was extensively used in the past, is now almost obsolete, mainly

because of the chances for error and the inaccuracies resulting from its use. Differential indexing gives accurate results, but it is not in common use because of the longer time required for setup. In certain instances this method offers the only solution for indexing numbers beyond the range of simple indexing.

*Direct Indexing* To accomplish direct indexing, it is necessary to remove the plunger pin at the back of the direct-indexing plate

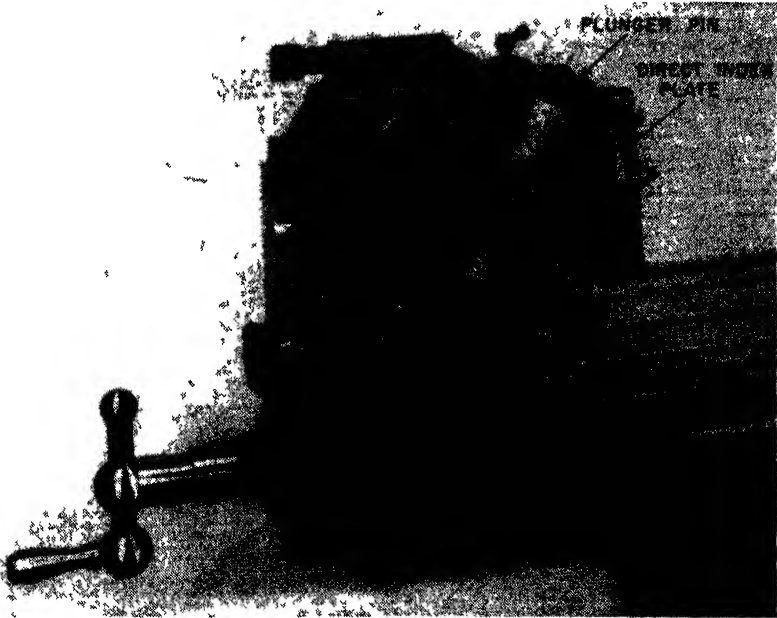
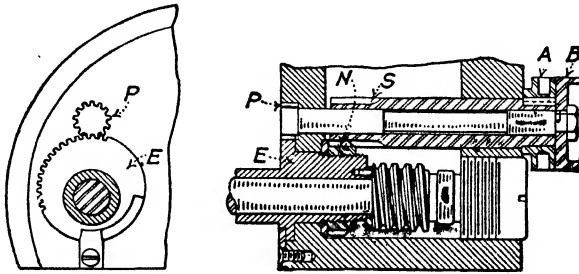


Fig. 9-11. The Brown & Sharpe index head showing the plunger pin and the direct-index plate (The Brown & Sharpe Manufacturing Company)

(Fig. 9-11). The construction of the universal index head permits disengaging the worm from the worm wheel. This is accomplished by turning, through part of a revolution, a knob or handle that operates an eccentric bushing or pin (Figs. 9-12 and 9-13).

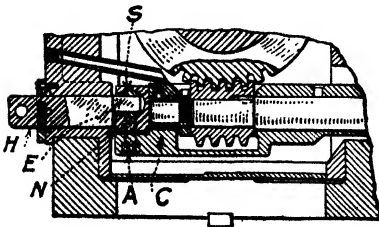
Direct indexing (often called *rapid indexing*) is accomplished after the worm is lowered from the worm gear. The spindle can then be turned freely and the distance measured by the number of holes on the direct-index plate passing the plunger pin. The direct-index

plate is to be found behind the threaded end of the spindle on a Brown & Sharpe index head. Near its outer edge it has 24 equally spaced holes, into which the plunger pin can be inserted (Fig. 9-11).



**Fig. 9-12.** Portion of *horizontal* section of a Brown & Sharpe index head. To lower the worm out of mesh with the worm wheel, *first disengage stop pin from index plate*, then turn knob *A* about one-quarter revolution in the *reverse* direction to that indicated by an arrow on *A*. This will loosen nut *N*, which clamps eccentric bushing *E*. (Note: The sleeve *S* and the nut *N* are provided with gear teeth.) After *N* is loosened, turn both knobs *A* and *B*; this will turn the pinion *P* and revolve the eccentric bushing *E*, which lowers the worm.

The plunger pin holds the plate in position. When the plate is turned by hand through the required part of a revolution, the index spindle and the work also turn, the same part of a revolution.



**Fig. 9-13.** Portion of *vertical* section of a Cincinnati index head. The worm is lowered out of mesh with the worm wheel by moving the handle *H* one-half turn. This operates eccentric *E*, which is journaled crosswise in the cylindrical sliding piece *S* carried in the holder *N*. The worm carrier *C* is fastened to *N* (by two screws *A*). Consequently, when the slide holder *N* is raised or lowered, the worm casing and the worm are raised or lowered.

Direct indexing is used to advantage for the milling of squares, hexagons, and fluting taps. Any number of divisions that is a factor of 24 may be quickly indexed, as 2, 3, 4, 6, 8, 12, and 24.

The Cincinnati dividing head is fitted with a direct-indexing plate that has three circles of holes, 24, 30, and 36. This plate makes rapid indexing possible for the following number of holes:

24-hole circle - 2, 3, 4, 6, 8, 12, 24

30-hole circle - 2, 3, 5, 6, 10, 15, 30

36-hole circle - 2, 3, 4, 6, 9, 12, 18, 36

To find the correct movement of the direct-index plate, divide the number of divisions required into the number of holes on the circle being used.

**EXAMPLE:** Determine indexing required to mill a hexagon on a Brown & Sharpe index head (24 holes).

**SOLUTION:**

1. Formula to be used is  $\frac{24}{N}$ .
2. Substitute 6 for  $N$  in formula:  $24\frac{4}{6}$
3. Spaces required for job equals  $24\frac{4}{6}$  or 4.
4. When cutting a hexagon, put plunger pin in every *fourth* hole on direct-indexing plate using the 24-hole circle. This will give an accurate hexagon.

*Simple Indexing.* Simple indexing, also called *plain indexing*, is accomplished by means of a mechanism (Fig. 9-14) which consists essentially of a 40-tooth worm wheel fastened to the index-head spindle, a single-threaded worm, a crank for turning the worm shaft and an index plate. Since there are 40 teeth in the worm wheel, one complete turn of the index crank will cause the worm wheel to make  $\frac{1}{40}$  of a turn or, in other words, *40 turns of the index crank revolves the spindle one full turn.*

If it is required to cut 8 equally spaced teeth on a reamer and 40 turns of the index crank makes one full revolution of the work, then  $4\frac{0}{8}$  or 5 turns of the index crank after each cut will space the circumference of the reamer for exactly 8 teeth. If it is required to equally space for 10 cuts, then  $4\frac{0}{10}$  or 4 turns of the index crank for each cut will give the desired result.

Note that in the examples given above, the answer in each case was a *whole number*. There are many cases in which a whole number



is impossible as an indexing result. For example, let it be required to index for 6 equal spaces; then  $40\frac{4}{6}$  equals  $6\frac{2}{3}$  turns. If 14 equal

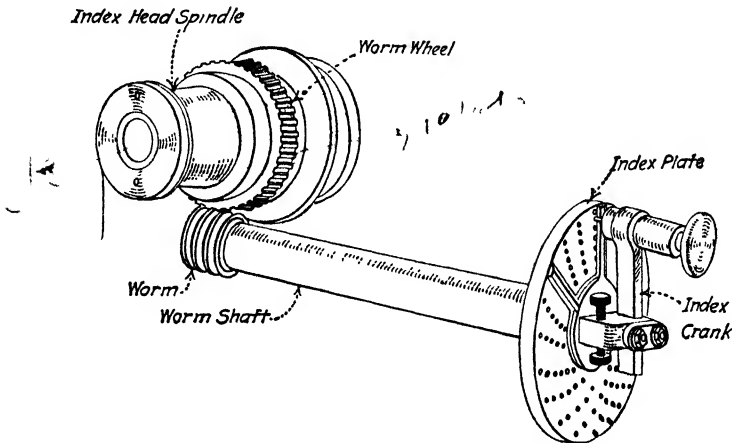


Fig. 9-14. Simple indexing mechanism.

spaces are required, then  $40\frac{4}{11}$  equals  $2\frac{6}{7}$  turns. In these examples, the answer was a mixed number.

#### **RULE FOR CALCULATING THE NUMBER OF TURNS OF THE INDEX CRANK**

To obtain the number of turns (whole or fractional) of the index crank for one division of any desired number of equal divisions on the work, divide the number of turns for one revolution of the spindle (usually 40) by the number of equal divisions desired.

The formula to find the number of turns is

$$T = \frac{40}{N}$$

where  $T$  = number of turns or parts of a turn and  $N$  = number of divisions required.

**EXAMPLE 1:** Index for 5 divisions.

**SOLUTION:** Using the formula above and substituting 5 for  $N$ , we get  $40\frac{4}{5}$  or 8 turns.

EXAMPLE 2: Index for 7 divisions.

SOLUTION: Using the above formula and substituting 7 for  $N$ , we get  $4\frac{0}{7}$  or  $5\frac{5}{7}$  turns.

EXAMPLE 3: Index for 48 divisions.

SOLUTION: Using the above formula and substituting 48 for  $N$ , we get  $4\frac{0}{48}$  or  $5\frac{5}{6}$  turn.

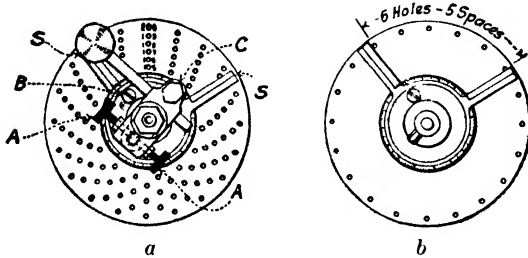


Fig. 9-15. Index plate and sector.

INDEX PLATE AND SECTOR. The fractional parts of a turn involve the use of an index plate and a sector. Referring to Fig. 9-14, it will be observed that the index pin at the end of the index handle enters a hole in the index plate. If only full turns were used in indexing, one hole only would be necessary; if only turns and half turns were required, two holes in opposite sides of the plate would answer; but a great number of different fractional parts of a turn are required for different spacings, and in order to measure them accurately and easily, the index plates and the sector are provided.

The *index plate* (Fig. 9-15) is a circular plate, arranged in front of the index handle, provided with a series of six or more circles of equally spaced holes.

The Brown & Sharpe Manufacturing Company regularly furnish index plates with circles of holes as follows:

- Plate 1 15-16-17-18-19-20
- Plate 2 21-23-27-29-31-33
- Plate 3 37-39-41-43-47-49

For divisions which cannot be obtained with any of these circles differential indexing is used.

The Cincinnati Milling Machine Company regularly furnishes one plate drilled on both sides which has circles of holes as follows:

First side—24-25-28-30-34-37-38-39-41-42-43  
 Second side- 46-47-49-51-53-54-57-58-59-62-66

This company furnishes as an "attachment," three plates drilled on both sides with holes as follows:

Plate	{	A	30-48-69-91- 99-117-129-147- 171-177-189
		B	36-37-81-97-111-127-141- 157-169-183-199
Plate	{	C	34-46-79-93-109-123-139-153-167-181-197
		D	32-44-77-89-107-121- 137-151-163-179-193
Plate	{	E	26-42-73-87-103-119-133-149-161-175-191
		F	28-38-71-83-101-113-131-143-159-173-187

The method of numbering the circles of holes in the index plates has been set by The Brown & Sharpe Manufacturing Company and the Cincinnati Milling Machine Company. Other manufacturers of index heads conform to one standard or the other.

The Kearney & Trecker Corporation conforms to the Brown & Sharpe method, while The LeBlond Machine Company's indexing attachment has almost the same circles as the Cincinnati.

With the index plates regularly furnished it is possible to obtain the spacings ordinarily used for gears, clutches, milling cutters, etc. Two examples will illustrate:

**EXAMPLE 1:** To mill a hexagon.

**SOLUTION:** Using the rule:  $4\frac{0}{6} = 6\frac{2}{3}$  turns, or six full turns and two-thirds of a turn on any circle divisible by 3; for instance, 12 spaces on the 18 circle or 26 spaces on the 39 circle.

**EXAMPLE 2:** To cut a gear of 42 teeth.

**SOLUTION:**  $4\frac{0}{42}$  or  $2\frac{0}{21}$  turns, that is, 40 spaces on the 42 circle (Cincinnati) or 20 spaces on the 21 circle (Brown & Sharpe).

Referring to Fig. 9-15, the index crank is adjustable radially (first loosen screw *C*), so that the index pin may be used in any of the circles of holes in the plate. The index pin is held in the hole by a spring contained in the handle and when the pin is pulled against the force of the spring, out of the hole, the crank may be moved.

The *sector* (Fig. 9-15) consists of two radial arms *S*, so constructed

that the angle included between them may be changed (first loosening the binding screw *B*). The use of the sector obviates the necessity of counting the holes, at each cut, for the fractional part of a turn, and in addition to saving time makes for accuracy. Select a circle divisible by the denominator of the required fraction of a turn (reduced to lowest terms) and bring the beveled edges of the arms of the sector to include the fractional part of the circle desired. In counting the holes in the plate when adjusting the sector *remember it is really the number of spaces between the holes that gives the desired fractional part of the whole circle*. Consider the hole the pin is in as zero. An example is illustrated in *b*, Fig. 9-15.

When the spindle is not clamped, the index handle should turn easily.

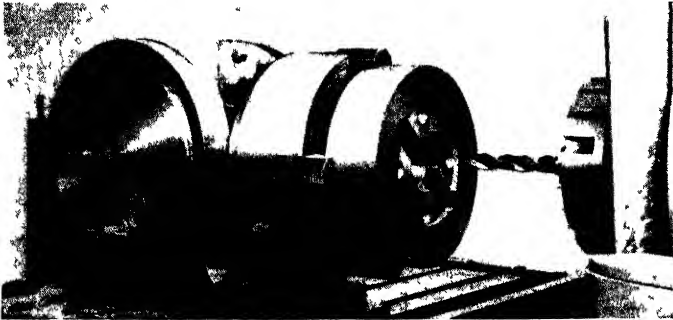
The sector is under spring tension so that it will remain set. It should, however, be easy to move to the next setting. Move the sector *immediately* after indexing, then it will always be in position for the next indexing operation.

The number of spaces on the index circle indicating the fractional part of a turn should be included between the *beveled* edges of the sector arms.

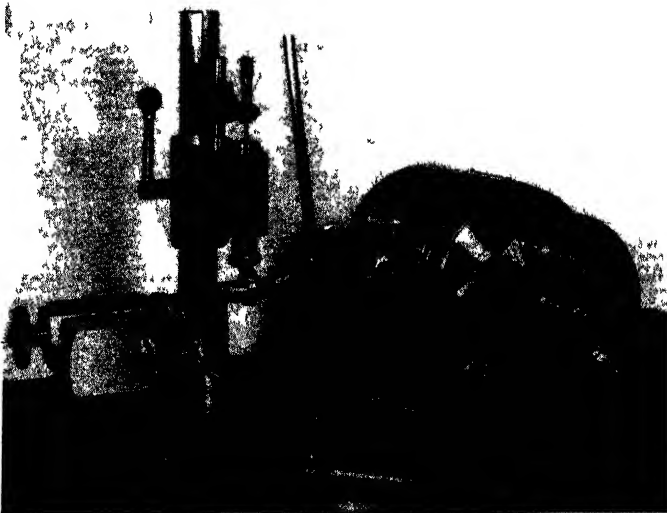
Form the habit of turning the *index handle to the right*, to avoid confusion. Stop between the last two holes and, gently rapping the handle, allow the pin to snap into place. If the handle is turned too far, turn it back far enough to *take up the lost motion* before allowing the pin to snap into place.

Sometimes after the work has been exactly adjusted—to a cut already made, for example—the index pin will come between two holes in the plate, and merely moving the pin to enter either hole will move the work a trifle, perhaps enough to spoil the cut. A means of allowing the pin to enter the nearest hole, *without moving the work at all*, is provided in the Brown & Sharpe machine by adjusting the screws *A* (Fig. 9-15); and in the Cincinnati machine, the index-plate lock is loosened, and the plate moved until one of the holes comes to the pin.

The worm and worm wheel and the spindle are so arranged within the swivel block as to permit of indexing in any position within the angular range, and this feature of the head is used for cutting clutches, end teeth on cutters, and many other jobs.



**Fig. 9-16.** Using the index head to locate holes at specified angles (*The Cincinnati Milling Machine Company*)



**Fig. 9-17.** The Index head being used to inspect a camshaft (*The Cincinnati Milling Machine Company*)

*Angular Indexing, or Indexing in Degrees.* Simple indexing can be used also for moving the spindle a specified number of degrees. This permits surfaces to be milled, or holes to be drilled, a required number of degrees from each other (Fig. 9-16). It also makes the index head suitable for use on the inspection table (Fig. 9-17).

There are 360 deg. in a circle and, since the index crank must turn 40 times to revolve the spindle one complete revolution, it can be seen that 40 turns of the index crank will turn the spindle exactly 360 deg. One turn of the index crank will revolve the spindle  $\frac{1}{40}$  of 360, or 9 deg. Consequently, one-ninth of one turn of the crank will rotate the spindle 1 deg.

In order to determine the number of turns, or a part of a turn, of the crank required to index for an angle given in degrees, it is necessary to divide the number of degrees movement required by 9.

EXAMPLE: Index for 72 degrees.

SOLUTION: Divide 72 by 9 and the answer is 8 turns.

Simple indexing can also be used to index fractional parts of a degree. Using the B&S dividing head, it is possible to index  $\frac{1}{3}$ ,  $\frac{2}{3}$ , and  $\frac{1}{2}$  of a degree if the 27-hole circle is used for the  $\frac{1}{3}$  and  $\frac{2}{3}$  of a degree. The 18-hole circle is used to index the  $\frac{1}{2}$  deg.

To index  $\frac{1}{3}$ ,  $\frac{2}{3}$ , and  $\frac{1}{2}$  deg., it is necessary to use a circle of holes divisible by 9.

EXAMPLE 1: Index for  $5\frac{1}{2}$  deg.

$$\text{SOLUTION: } \frac{5\frac{1}{2}}{9} \times \frac{2}{2} = \frac{11}{18}$$

The fraction  $11\frac{1}{18}$  means that 11 holes on the 18-hole circle must be used.

EXAMPLE 2: Index for  $6\frac{2}{3}$  degrees.

$$\text{SOLUTION: } \frac{6\frac{2}{3}}{9} \times \frac{3}{3} = \frac{20}{27}$$

The fraction  $20\frac{2}{27}$  means that 20 holes on the 27-hole circle must be used.

The 54-hole circle on the standard plate provided by the Cincinnati indexing attachment permits the indexing of  $\frac{1}{3}$ ,  $\frac{2}{3}$ ,  $\frac{1}{2}$ , and  $\frac{1}{6}$  of a degree. For smaller divisions than  $\frac{1}{3}$  deg. on a B&S index head, the method of differential indexing must be used. For smaller than  $\frac{1}{6}$  deg. on the Cincinnati, one of the extra plates may be used (Fig. 9-18a).

*Approximate Indexing in Minutes.* If it is required to index angles given in minutes and if some tolerance is allowed, the index crank

movement and the correct index plate can be determined as follows: If one turn of the index crank revolves the spindle 9 deg., then 9 multiplied by 60 will equal the number of *minutes* obtained with one turn of the index crank ( $9 \times 60 = 540$  min.). This number, 540, divided by the number of minutes required will give the circle of holes on the index plate on which the index pin should be moved one hole. This one-hole movement of the crank on this given circle of holes will result in the required number of minutes.

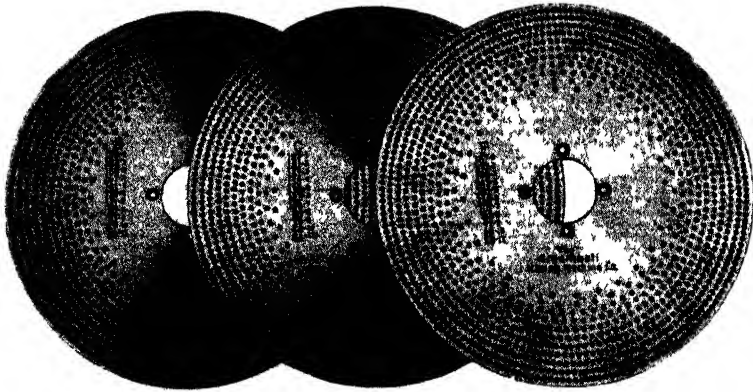


Fig. 9-18a. High-number indexing plates, drilled on both sides, giving a wider range of indexing (*The Cincinnati Milling Machine Company*)

OHIO

This method can be used only for approximate angles, since the resultant number may be one for which no index plate is available. However, if the number is nearly equal to a circle of holes in an index plate, that circle can be used with a slight error resulting.

EXAMPLE: Index for 24 min.

SOLUTION:  $540 \div 24 = 22.5$

There is no 22.5 circle of holes on the index plate, but a 23-hole circle could be used.

† Brown & Sharpe have simplified the accurate indexing of angles in degrees and minutes by making available angular indexing plates (Fig. 9-18b). An angular indexing plate can be attached to the index

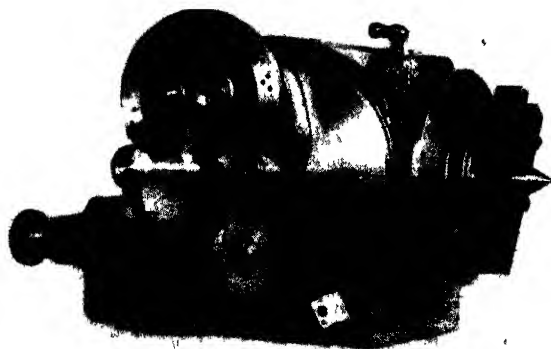


Fig. 9-18b. Angular indexing plate mounted on the headstock (*The Brown & Sharpe Manufacturing Company*)



Fig. 9-18c. Cutting a special disk, using an angular index plate. (*The Brown & Sharpe Manufacturing Company*)

head in place of the standard index plate. It has two circles of holes. The inner circle has 18 holes, each hole representing  $\frac{1}{2}$  deg. The outer circle contains 30 holes, each hole representing 1 min. Both the back pin and the index-crank pin are used with the plate. At times, both pins are withdrawn from the plate, which can then be revolved in either direction (Fig. 9-18c).

X



*Differential Indexing.* There are many divisions of the circle that are not possible to obtain with simple indexing. It then becomes necessary to use the method known as *differential indexing*.

The term *differential* is used because the needed division is obtained by a combination of two movements: (1) the simple indexing movement of the index crank, and (2) the movement of the index plate itself. These two movements happen at the same time with a *differential* in their movement relationship.

The amount that the plate moves for each turn of the index crank and the direction in which it moves are governed by change gears. This will be explained in detail in a later section.

Differential indexing may be used for divisions that cannot be obtained by simple indexing. With the change gears and the three index plates that are standard equipment with the B&S index head, it is possible to index all numbers not obtainable by simple indexing, from 1 to 382. In addition, many other divisions beyond 382 can be indexed.

The index-head spindle and the index plate are connected by a train of gears so that the index plate will turn either in the same direction as the movement of the crank or in the opposite direction, depending upon the requirements of the job. The stop pin at the back of the index plate must be released from the plate before the gears can be operated.

The speed of the movement must be exact, so that when the crank has been moved the precise amount, the index-plate movement will also be precise. This will result in the exact alignment of the latch pin with a hole in the index plate. The gears to use and their arrangement offer about the same problems as gearing a lathe for cutting threads. It is first necessary to understand how the index plate is caused to move.

In simple indexing, the index plate is held from turning by a stop pin; the index crank is turned and serves to revolve the worm shaft in the sleeve *L* (Fig. 9-19) and the worm moves the worm wheel and the index-head spindle. Again it must be emphasized that in differential indexing, the stop pin is withdrawn.

Note in Fig. 9-19 that the gear  $B_3$  and the index plate are both fastened to the sleeve *L*; therefore if the gear  $B_3$  is caused to move, the plate will move. To do this, a train of gears is arranged between the index-head spindle and the auxiliary worm shaft *M*.

The permanent gears within the index head are diagramed in Fig. 9-19, to show how this motion is transmitted. The explanation follows:

A special arbor is fitted and held securely in the taper hole in the index-head spindle and is hereafter referred to as the "spindle." One end serves as the live center and the other end projects through and holds the spindle gear *S*.

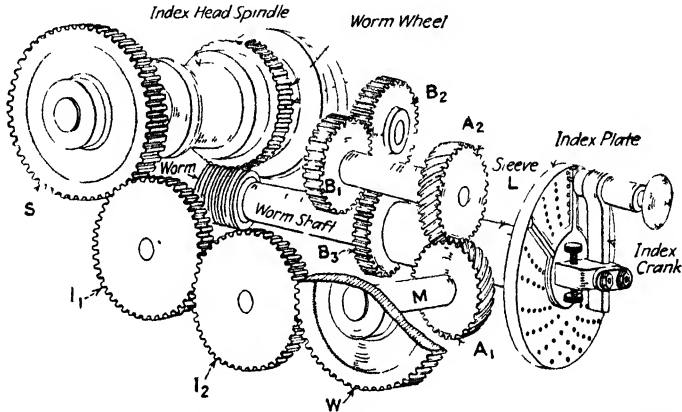


Fig. 9-19. This figure illustrates the gearing for differential indexing with a Brown & Sharpe index head (extended for clearness). In practice, one idler, or two idlers, or a compound of any two of the change gears with or without an idler, may be used between the gears *S* and *W*.

Arrange the train of gears: the spindle gear *S*, the idler gears *I*<sub>1</sub> and *I*<sub>2</sub>, and the worm gear *W* (on the auxiliary worm shaft *M*). Disengage the stop pin that locks the index plate to the head, turn the index crank and note the following: (1) The spindle, and the gear *S*, are put in motion by the movement of the index crank, through the worm shaft, worm, and worm wheel, in the ratio of 40:1, as in simple indexing. (2) The movement of the spindle gear *S* is transmitted through *I*<sub>1</sub> and *I*<sub>2</sub> to gear *W*. (3) From *W*, through shaft *M*, the motion is given to spiral gear *A*<sub>1</sub>, to other spiral gear *A*<sub>2</sub>, to *B*<sub>1</sub>, which is fastened to the same stud as *A*<sub>2</sub>. The gear *B*<sub>2</sub> is an idler gear, and motion is transmitted from *B*<sub>1</sub> through *B*<sub>2</sub> to *B*<sub>3</sub>, the sleeve *L* and the index plate. (4) The amount the index plate will move, relative to the movement of the index handle, will depend upon the relative sizes of the driving and driven gears (as *S* and *W*, in simple train or com-

pounded). (5) The movement of the index plate may be in the direction of the movement of the index crank, or in the opposite direction, according to whether one or two idlers are used.

Suppose there are equal gears,  $S$  and  $W$ , on the "spindle" and the "worm," respectively, with two idlers between them, and that the index pin is in a hole in the index plate referred to here as (1). Now pull out the index pin and move the index handle clockwise, then the index plate will move counterclockwise, and 40 turns of the index handle will cause the *index plate* to make one revolution, and the index pin will have caught up with the (1) hole just 41 times. If the handle is stopped each turn, that is, each time the pin comes to the (1) hole, and a cut is made—in a gear blank, for example—a gear of 41 teeth will be cut.

Now if only one idler is used, the movement of the index plate is clockwise, or in the same direction as the movement of the index handle. By making 40 turns of the index handle, the pin catches up with the (1) hole just 39 times, because of the one whole turn of the plate itself. If a cut is made each time the pin reaches the (1) hole, 39 cuts will be made.

Investigate a little further by putting a 48-tooth gear on the spindle, a 24-tooth gear on the worm, and use one intermediate. The ratio of the spindle to the worm is then 2:1, and when the spindle revolves once, the index plate will revolve twice, and the index pin will have caught up with the (1) hole 38 times.

With the above setting (with one idler), a "turn" from (1) hole to (1) hole each indexing will give 38 divisions; with 2 turns, 19 divisions; with  $\frac{1}{2}$  turn, 76 divisions;  $\frac{2}{3}$  turn, 57 divisions, etc. With two idlers, divisions as follows may be made: 1 turn, 42; 2 turns, 21;  $\frac{1}{2}$  turn, 84;  $\frac{2}{3}$  turn, 63 divisions, etc.

With a ratio, spindle to worm, of 3:1, the machinist can make, with one idler, 1 turn, 37 divisions;  $\frac{1}{2}$  turn, 74 divisions, etc. With two idlers, 1 turn, 43 divisions, etc.

Take a fractional ratio of spindle to worm, for example,  $\frac{2}{3}:1$  (that is, 2:3), 32 gear on spindle, 48 gear on worm:

$$40 - \frac{2}{3} = 39\frac{1}{3}$$

One-third turn ( $39\frac{1}{3} \div \frac{1}{3}$ ) gives 118 divisions.

Two-thirds turn ( $39\frac{1}{3} \div \frac{2}{3}$ ) gives 59 divisions, etc.

Enough has been said to illustrate the principle of differential indexing, how different ratios of gears from spindle to worm give divisions, such as prime numbers, that would otherwise be impracticable if not impossible. Following is an explanation of how the gear ratios are calculated, and, to simplify the calculations, definitions and notations are given.

**DEFINITIONS AND NOTATIONS: DIFFERENTIAL INDEXING**

*Simple Index Number* (40). The number of turns of the index handle to turn the spindle one revolution as in simple indexing.

*Differential Index Number (D)*. The number of moves (turns) of the index handle [from (1) hole around to (1) hole] necessary to make one complete revolution of the spindle.

*Change-gear Ratio (x)*. The ratio of the train of gearing between the spindle and the worm (and, *in effect*, between the spindle and the index plate).

*NOTE:* It will be observed from the examples given that the change-gear ratio is always the ratio of the difference between the simple index number and the differential index number and 1. For instance, in one of the examples given above the difference between 40 and  $39\frac{1}{3}$  is  $\frac{2}{3}$ , or a *ratio* of spindle to worm of  $\frac{2}{3}:1$  or  $2:3$ .

- (1) 40 = simple index number
  - (2) D = differential index number
  - (3) N = number of divisions required
  - (4)  $N_1$  = some number of divisions, usually quite near the required number, that may be obtained by simple indexing
  - (5) S = gear on spindle
  - (6)  $G_1$  = first gear on stud
  - (7)  $G_2$  = second gear on stud
  - (8) W = gear on worm
- } driving gears
- } driven gears
- (9)  $D:40 = N:N_1$  that is,  $D = \frac{40N}{N_1}$
- (10)  $x = \text{ratio} = (40 - D):1$ , when 40 is larger than D
- (11)  $x = \text{ratio} = (D - 40):1$ , when D is larger than 40
- (12)  $x = \frac{S}{W}$  (for simple gearing)
- (13)  $x = \frac{S \times G_1}{G_2 \times W}$  (for compound gearing)
- (14) The ratio should not exceed 6:1 on account of the excessive stress on the gears.

(15) When the differential index number is less than 40, use one idler (or the compound); when greater than 40, use two idlers (or one idler and the compound).

(16) The movement of the index handle will be the fraction of a turn indicated by  $\frac{40}{N_1}$ .

**NOTE:** The numbers in parentheses in the following explanation and examples are references to the notations above.

Method of calculations:

a. Select  $N_1$  (4)

b. Substitute for  $N_1$  its value, and solve for  $D$  (9)

c. Find the ratio (10) or (11)

d. If the ratio is not practicable (14), select another number for  $N_1$  and try again

e. Having ratio, arrange simple gears (12)

or compound gears (13)

f. Set the index pin and sector (16)

**EXAMPLE:**  $N = 59$ . (3)

**SOLUTION:**  $\frac{D}{40} = \frac{N}{N_1}$        $\frac{D}{40} = \frac{59}{60}$  (9)

$$60D = 40 \times 59$$

$$D = \frac{40 \times 59}{60}$$

$$D = 39\frac{1}{3}$$
 (9)

$$x = (40 - 39\frac{1}{3}):1 = \frac{2}{3}:1, \quad \text{or} \quad 2:3 \quad (10)$$

$$\frac{2}{3} = 4\frac{8}{72}; \quad 48 \text{ gear on } S, \quad 72 \text{ gear on } W \quad (12)$$

$$\text{Use one idler, } I \quad (15)$$

$$\text{Movement of index handle } 4\frac{0}{60} = \frac{2}{3} \text{ turn} \quad (16)$$

*Alternate Method of Finding Differential Indexing Setup.* Figure 9-20 shows a Brown & Sharpe index head geared for 271 divisions. Select an approximate number of divisions ( $A$ ) that is either greater or smaller than the required number ( $N$ ). The approximate number selected when divided by a factor of 40 will give a number that can be indexed by plain indexing. Form a fraction with 40 as the numerator and the approximate number ( $A$ ) as the denominator. Reduce to a fraction having as a denominator a number equal to the

holes in an index plate. To illustrate for 271 divisions:  $A = 280$

$$40_{280} = 1/7 \times 3/3 = 3/21$$

which means using 3 holes on the 21-hole circle.

The formula for finding the gearing ratio is as follows: Let  $R$  equal the required ratio of gearing; let  $N$  equal the required number of

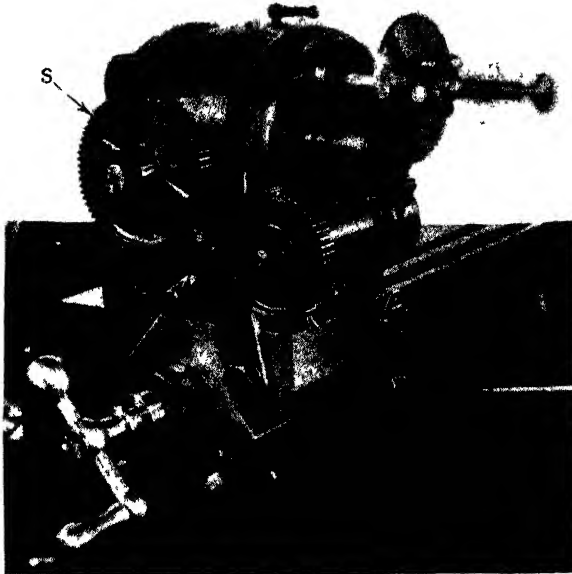


Fig. 9-20. A Brown & Sharpe index head geared for 271 divisions. (*The Brown & Sharpe Manufacturing Company*)

divisions; and let  $A$  equal the approximate number. Then

$$R = (A - N) \times \frac{40}{A}$$

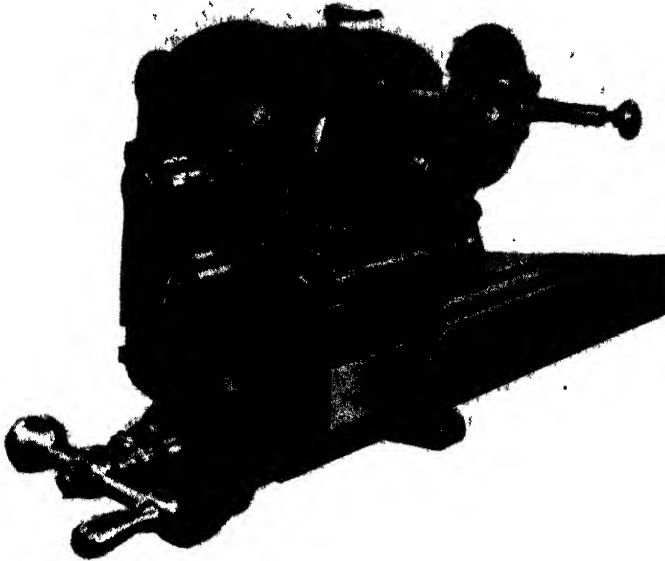
EXAMPLE: If the required number ( $N$ ) is 271 and the approximate number ( $A$ ) is 280, then

$$R = (280 - 271) \times 40_{280} = 9/1 \times 40_{280} = 9/7$$

$\frac{9}{7}$  is the ratio of the *driver* to the *driven* gears. The fraction  $\frac{9}{7}$  when raised to obtain numbers equivalent to available gears will be

$$\frac{9}{7} \times \frac{8}{8} = \frac{72 \text{ on spindle}}{56 \text{ on worm}}$$

The purpose of idler or intermediate gears in the gear train used for differential indexing is to (1) rotate the index plate in the same



**Fig. 9-21.** A Brown & Sharpe index head geared for 250 divisions (two idlers).  
(The Brown & Sharpe Manufacturing Company)

direction as the crank, or (2) to rotate the index plate in the opposite direction. The direction depends upon whether it is necessary to either increase (1) or decrease (2) the indexing movement.

When the approximate number ( $A$ ) is *greater* than the required number ( $N$ ), the index plate and the crank revolve in the *same* direction. Simple gearing will require one idler; compound gearing, no idler. When  $A$  is *less* than  $N$ , simple gearing will require two idlers and the compound gearing will require but one idler. The indexing

plate and the crank must rotate in opposite directions in this case (see Fig. 9-21).

Compound gearing will be required when the ratio of gearing does not conform to the available gear sizes or is impracticable to use. Figure 9-22 shows a B&S index head geared for 319 divisions with

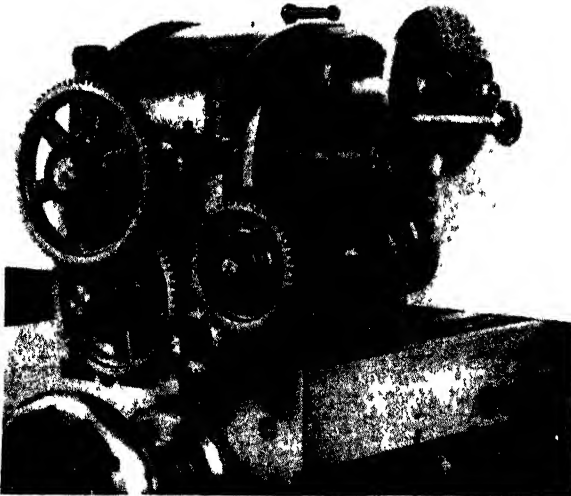


Fig. 9-22. A Brown & Sharpe index head geared for 319 divisions (compound gearing with one idler) (*The Brown & Sharpe Manufacturing Company*)

compound gearing and one idler. Let  $A$  equal 290 and  $N$  equal 319. Then using the formula

$$R = (N - A) \times 40/A$$

Substituting the values for  $N$  and  $A$  we get

$$R = (319 - 290) \times 40/290 = 29/1 \times 40/290 = 4/1$$

In terms of gears (compound) we get

$$\frac{4}{1} \times \frac{3}{3} = \frac{12}{3}, \quad \frac{3 \times 4}{1 \times 3}$$

$$\frac{3}{1} \times \frac{24}{24} = \frac{72}{24} \quad \frac{4}{3} \times \frac{16}{16} = \frac{64}{48}$$



Combining both fractions, we get

$$\frac{72 \times 64 \text{ drivers}}{24 \times 48 \text{ driven}}$$

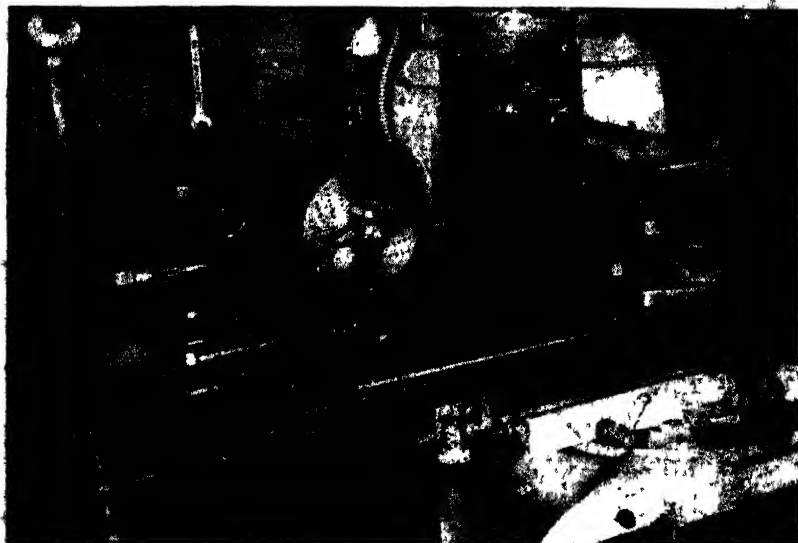
Since  $A$  is less than  $N$ , compound gearing will require but one idler.

$$\text{Movement of the index crank} = \frac{40}{290} = \frac{4 \text{ holes}}{29 \text{ circle}}$$

Change gears available with the B&S index head have the following teeth: 24 (two gears), 28, 32, 40, 44, 48, 56, 64, 72, 86, 100.

**Graduating with the Index Head.** Although the index head is regarded mainly as an attachment for dividing the circumference of work into accurate spaces, it can also be used for the accurate division of flat stock. This procedure is known as *graduating* and is used for accurate spacing of the divisions on flat scales and verniers.

The operation requires the use of the universal spiral index head and a single pointed tool, which is held stationary in a fly-cutter arbor or boring bar, mounted directly in the spindle. The scale to be



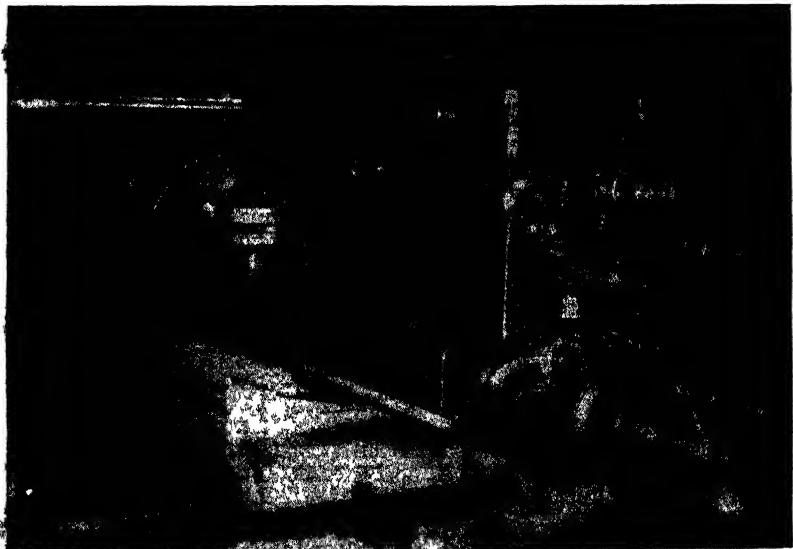
**Fig. 9-23a.** The Brown & Sharpe index head geared for graduating a flat scale or a flat surface. (James Anderson)

graduated is clamped to the surface of the table parallel to the slots or mounted in a vise or a fixture. No power is required, the lines are cut by moving the table transversely under the point of the cutting tool. This movement is done by hand (see Figs. 9-23a and 9-23b).

The dividing-head spindle is geared to the table feed screw with compound gearing. The indexing for the divisions required is obtained by moving the index crank the necessary number of holes on a particular circle of the index plate. The movement of the index crank rotates the spindle, the gear attached to the spindle transmits the movement through the gear train to the table feed screw.

It has already been explained that one turn of the index crank moves the headstock spindle  $\frac{1}{40}$  of a revolution. If equal gearing is employed between the spindle and the table feed screw, the feed screw will likewise turn  $\frac{1}{40}$  of a revolution.

The lead screw of a milling-machine table has four threads to the inch. The pitch of the thread is 0.250 in. Therefore, one turn of the index crank will move the table  $\frac{1}{40}$  of 0.250 in., or 0.00625 in.



**Fig. 9-23b.** Rear view of the graduating setup, showing the gearing used between headstock spindle and feed screw (*James Anderson*)

Suppose it is required to graduate a scale with lines 0.03125 in. apart. Quick observation will tell that, if one turn of the index crank moves the table a distance of 0.00625 in., it will take more than one turn to move the table a distance of 0.03125 in. Therefore,  $\frac{0.03125}{0.00625} = 5$  turns are needed of the index crank to space a distance of 0.03125 in.

If it is required to index the divisions on a vernier reading to a thousandth of an inch (0.001 in.) and the divisions are 0.024 in. apart, the indexing movement will be  $\frac{0.024}{0.00625} = 3.84$  turns. The fractional movement of 0.84 turn can be obtained within close limits by indexing 26 holes in the 31-hole circle. Three complete turns will move the table  $0.00625 \times 3 = 0.01875$  in. and  $\frac{26}{31}$  of a turn will give a table movement equal to  $0.00524 +$  in. Therefore, 0.01875 plus 0.00524 equals 0.02399, which is 0.00001 in. less than the required amount of 0.024 in.

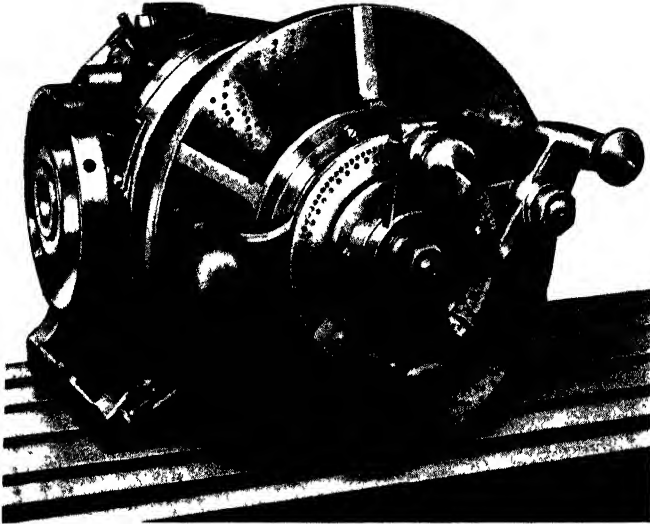
In order to prevent errors caused by any play or backlash, either in the gearing of the index head or wear between the threads of the table feed screw and nut, the index crank must always be turned in one direction, preferably clockwise—to the right.

The *Practical Treatise on Milling and Milling Machines*, published by the Brown & Sharpe Manufacturing Company, includes several pages of tables compiled by that concern for determining the circle and holes to be used for longitudinal graduating.

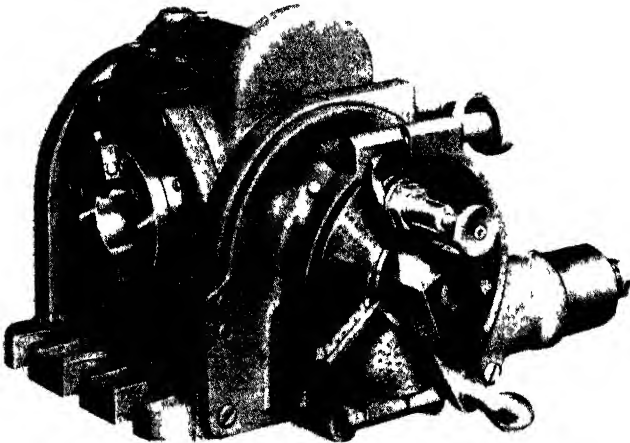
**Wide-range Divider.** The Cincinnati Milling Machine Company has a *wide-range divider* unit that can be applied to a Cincinnati universal dividing head (Fig. 9-24). It can be used for divisions ranging from 2 to 400,000 and for any desired angle in degrees, minutes, and seconds. The three indexing plates shown in Fig. 9-18a are utilized to obtain this wide range of divisions. The ratio between the worm shaft and the spindle is 40 to 1. The mechanism operates through a reduction gearing of 100 to 1 ratio within the housing.

The 40:1 ratio between the index crank and the spindle will be found in nearly all the index heads used in modern machine shops. However, there is one exception which merits description.

The Kearney & Trecker Corporation manufacture a dividing head that has a 5:1 ratio between crank and spindle. The model K uni-

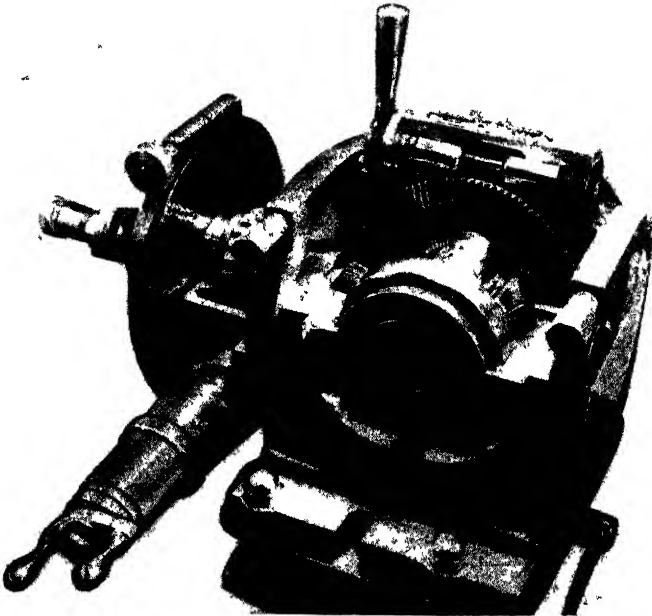


**Fig. 9-24.** The Cincinnati universal index head with a wide-range divider (*The Cincinnati Milling Machine Company*)



**Fig. 9-25a.** The Kearney and Trecker (Milwaukee) Model K universal spiral dividing head, 5 to 1 ratio (*The Kearney and Trecker Corporation*)

versal dividing head, Fig. 9-25a, has such a ratio. This company claims that more than 90 per cent of all indexing operations lie between 6 and 36 divisions. Using a 40:1 ratio dividing head, more than one full turn of the index crank is required to index any of these divisions. With a 5:1 ratio model K, all numbers within this 6 to 36 division range can be indexed with less than one revolution of the index crank. The movement between the index crank and the



**Fig. 9-25b.** The Kearney and Trecker (Milwaukee) Model K dividing head showing the hypoid bevel gearing, 5 to 1 ratio (*The Kearney and Trecker Corporation*)

spindle is transmitted through a hypoid bevel gear and a pinion (Fig. 9-25b).

One index plate comes as standard equipment for this index head. It consists of two standard plates bolted and doweled together. The plate can be reversed, making available seven circles of holes on each plate. These plates have the following circles of holes: No. 1—98, 88, 78, 76, 68, 58, 54 and No. 2—100, 96, 92, 84, 72, 66, 60.

A set of two high-number index plates are made available also. With the three plates it is possible to index for all divisions from 2 to 100, plus many other divisions up to 500 (Fig. 9-25c).

Because of the ease of obtaining the lower number of divisions, a direct indexing plate is found unnecessary.

The design of this index head provides for mounting gears for differential indexing.

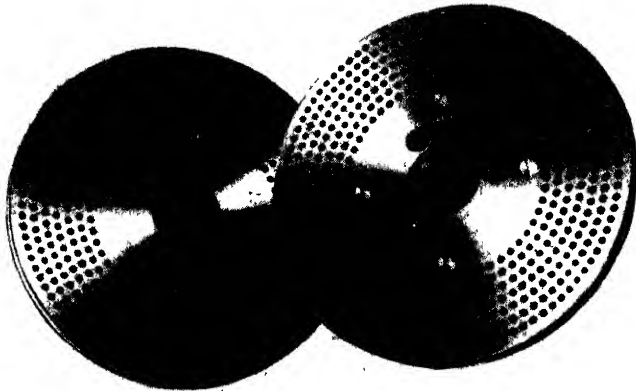


Fig. 9-25c. A set of two high-numbered index plates available with the Kearney and Trecker (Milwaukee) 5:1 index head. (*The Kearney and Trecker Corporation*)

The index-crank setting is calculated in the same way as for other dividing heads, except that 5 is used in place of 40. Thus, to index for the cutting of a 36-tooth gear, the following will illustrate the procedure:

$$\frac{5}{N} = \frac{5}{36} \text{ of a turn}$$

$$\frac{5}{36} \times \frac{2}{2} = \frac{10 \text{ holes}}{72 \text{ circle}} \quad \text{No. 2 plate}$$

### QUESTIONS ON THE INDEX HEAD AND INDEXING

1. Define the machine operation called *indexing*.
2. How many turns of the index crank are necessary in order to rotate the spindle one full turn? Use the Brown & Sharpe index head.

3. How many index plates are considered standard equipment for the Brown & Sharpe head?
4. Give number of the plate and the circles of holes on each.
5. How many turns are necessary to index for a gear of 20 teeth; 40 teeth; 80 teeth?
6. Where is the direct index plate located on the Brown & Sharpe dividing head?
7. How many spaces will it require to turn the direct indexing plate in order to cut a square?
8. Name the methods of indexing in modern use.
9. What parts of the indexing mechanism must be disengaged before using the direct method of indexing?
10. Give the formula required to solve direct indexing problems.
11. How many circles of holes are there on the direct indexing plate of the Brown & Sharpe head? On the Cincinnati head? Give numbers.
12. How many turns of the index crank are required to space the eight flutes of a reamer?
13. Give the formula required for solving problems by simple indexing. Use a Brown & Sharpe index head.
14. Give the index-head setting, turns, holes, and circle used to cut 14 teeth.
15. How many degrees will the index-head spindle move if the index crank is turned one complete revolution?
16. Give the index setting for  $6\frac{1}{2}$  degrees.
17. What circles of holes are used in the Brown & Sharpe head to index  $\frac{1}{3}$  and  $\frac{1}{2}$  deg.?
18. How many degrees and minutes will the spindle revolve if the crank is revolved  $4\frac{1}{2}$  turns?
19. What is the purpose of differential indexing?
20. Give the formula used in the alternate method of finding the differential indexing setup.

### TYPICAL INDEXING OPERATIONS

**Milling a Square or a Hexagon.** The size of a square or a hexagon is always given as the distance across the flats, *not* across corners. The distance across the corners will give the diameter of the stock on which the square or the hexagon may be cut.

The diameter multiplied by 0.707 will give a square with sharp corners. The diameter multiplied by 0.750 will give a larger square with slightly rounded corners. This is more desirable for the squares on taps and reamers.

Whenever it is necessary to mill a surface at the end of a long piece, it will be good practice either to mount the work between centers or to hold one end in the index-head chuck while the other end is supported by the footstock (Fig. 9-26). To remove the center from the headstock, turn the headstock spindle to a horizontal position. Drive out the center by using a piece of brass rod  $\frac{3}{4}$  in. in diameter by 8 in. long. Turn the headstock so that the spindle is vertical, remove the protective ring from the threaded nose, wipe off the threads, and screw the chuck on to the spindle. Be sure the chuck threads are clean and screwed on tightly against the spindle shoulder.

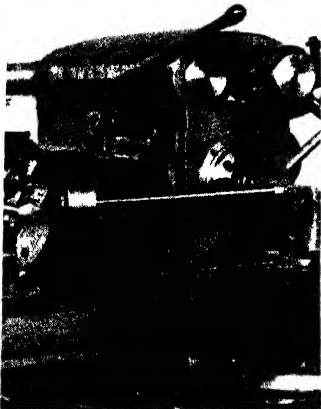


Fig. 9-26. Milling a square end on a long piece. Index-head spindle is horizontal.

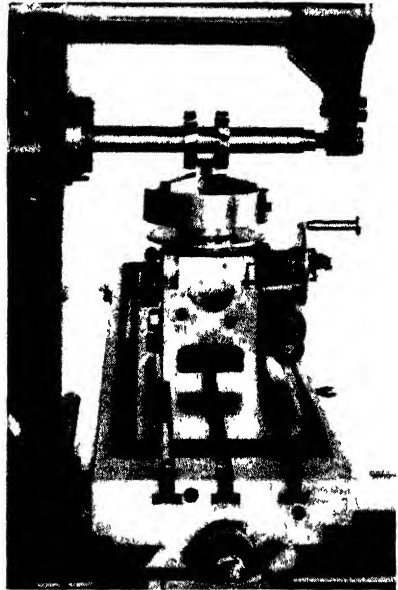


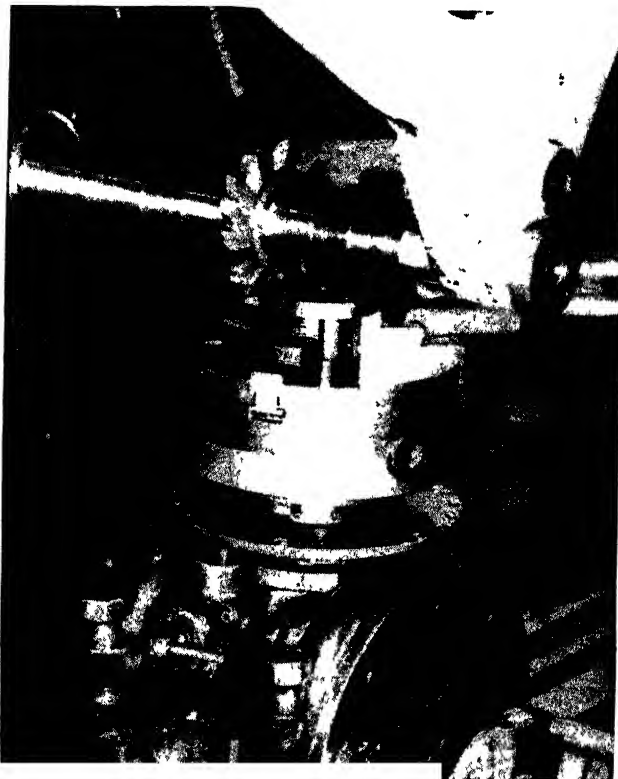
Fig. 9-27. Straddle-milling a bolt head to a sized square. (*The Brown & Sharpe Manufacturing Company*)

*Using an End Mill.* When the work is held vertically, the regular table feed may be used and the cutting action may be more easily observed. If a square is to be milled on the end of a long piece, it will best be done by using an end mill (Fig. 9-26). Drive home the end mill with a block of hardwood and a hammer (see Fig. 8-29). The amount of stock to be removed from each side will equal one-half the difference between the diameter of the piece and the width of the finished square. Take a trial cut on opposite sides of the first piece



(1) to check for size and (2) to check to see if the cut is parallel. Once these things have been established, each surface can be finished with one cut.

**Straddle Milling** (Fig. 9-27). If a number of pieces require milling on opposite sides, as for example a bolthead, the best and



**Fig. 9-28.** The *incorrect* method of milling a flat on a flanged bushing. (James Anderson)

most economical method is by *straddle milling*. This requires two side-milling cutters of the same diameter mounted on the machine arbor with a spacing collar placed between them. The spacing collar must be the exact length of the required width of the bolthead and must clear the top of the job as it passes between the cutters.

## OPERATION SHEET

## Straddle-milling a Bolthead to Squared Size

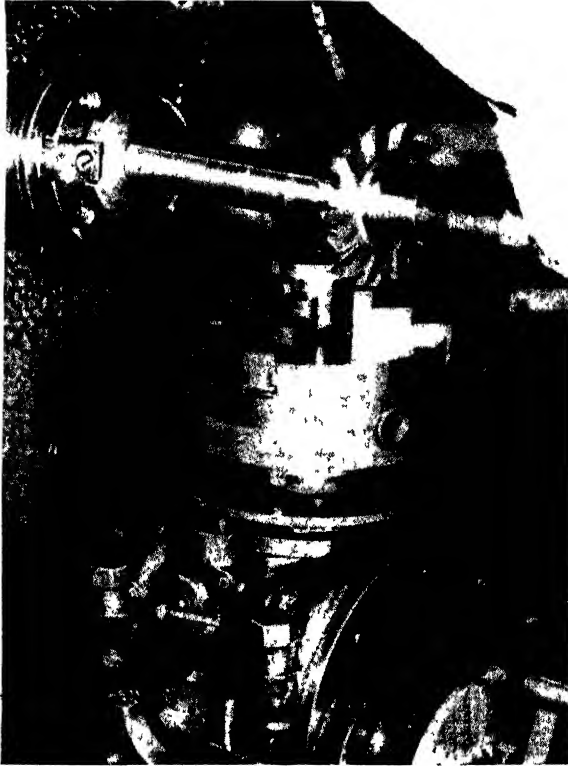
## Operations

1. Clean machine table and face of index head base.
2. Mount the index head on table. Mount head near to operating end of machine to avoid unnecessary stretching.
3. Clean hole in spindle and tapered shank of arbor. Place arbor in spindle and tighten draw-in bolt.
4. Clean arbor and collars; remove all burrs from the faces of the collars.
5. Secure proper cutters and mount with spacing collars between them in suitable position on arbor.
6. Clamp arbor yoke on overarms and arbor.
7. Tighten arbor nut. *Never* tighten or loosen arbor nut until the arbor is supported by the arbor yoke; this will prevent bending the arbor.
8. Mount chuck on index spindle. First clean and oil threads on spindle and chuck.
9. Swing index spindle to vertical position.
10. Clamp bolthead in chuck. Leave space between the bolthead and the chuck jaws to allow cutter to clear.
11. Centralize cutters with bolthead. Tighten saddle and knee-clamp levers and take trial cut.
12. Measure width of trial cut and make adjustments as required. If the final cut is too small, add extra spacing collars made of paper or thin metal. If the cut is oversize, either put in smaller spacing collar or face collar to required size.
13. Establish size and complete the cut.
14. Index for 90 deg. (10 turns) and take cut.
15. Remove bolt from chuck, test for size and squareness.
16. Remove all burrs and submit for inspection.

There are many occasions when a job requires only one flat side to be milled. This operation also requires the use of a side-milling cutter and, since the job is round in shape, it is held in an index head.

Figure 9-28 shows the *incorrect* method of milling the job for these reasons:

1. The flange of the job is resting on the jaws of the chuck, allowing no clearance for the teeth of the cutter.
2. The cutter is on the wrong side of the job. The cutter is moving in a clockwise direction and, since the chuck has a right-hand thread,



**Fig. 9-29.** The *correct* method of milling a flat on a flanged bushing. (*James Anderson*)

the first few shocks of teeth cutting the metal will tend to jar the chuck loose and spin the job into the cutter.

Figure 9-29 shows the *correct* method of mounting the job for milling.

**Holding Work for Drilling.** The index head is an invaluable aid when holes in round stock must be drilled in exact relation to each other. The drill chuck is mounted, by means of a special shank, into

the spindle of the machine (Fig. 9-30). Once the index head is centered with the machine spindle, holes can be drilled in the stock at different heights and angles.

The table of the machine can be lowered or raised distances exact

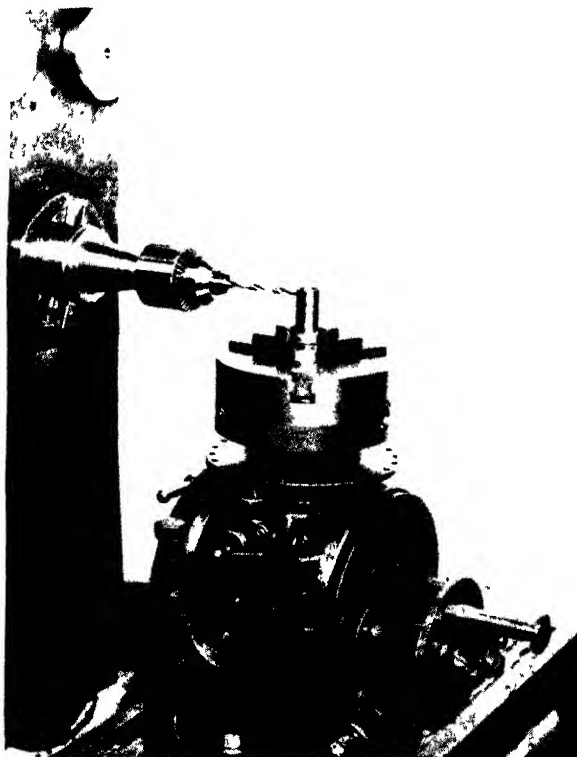
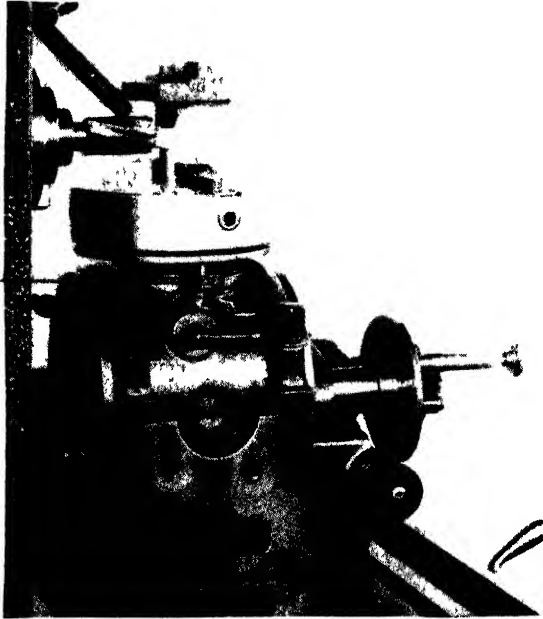


Fig. 9-30. Drilling holes in work held in the index head (*James Anderson*)

to a thousandth of an inch, and this is made possible by the graduations on the vertical adjustment handwheel dial. Holes can be drilled at various and accurate angles measured by the index crank and the index plate. This method is helpful when holes of different heights and angles are required to match holes in another part of the job.

**Index Head Used for Rotary Milling.** Although not designed for this type of work, the index head can be used within certain limitations as a means of making an uninterrupted cut around seg-

ments of circles or circular slots. Figure 9-31 shows a piece of work held in a three-jawed chuck on the nose of a dividing head. An end mill held in the machine spindle is milling the radius, blending the cut into a straight side of the job.



**Fig. 9-31.** Rotary milling using the index head (*The Brown & Sharpe Manufacturing Company*)

The cut is made by rotating the headstock by means of the hand crank. The hand crank is extended to its extreme length in order to make turning easier.

### QUESTIONS ON TYPICAL INDEXING OPERATIONS

1. What care must be taken when putting the chuck on any machine spindle?
2. How is the index-head center removed?
3. What is the purpose of the cap in the end of the index-head spindle?

4. If a considerable number of bolts are to be squared, why is straddle milling the best method?
5. If it is desired to use a pair of side mills for straddle milling, will a collar of the same thickness as the width of the cut be used? What thickness will be used?
6. Why are the collars for milling arbors furnished in various thicknesses or lengths?
7. Why are spacers of thin metal valuable when straddle mills are used? Could paper be used? Explain.
8. How many turns of the index handle are necessary to mill a hexagon bolthead? What circle do you use? How many holes? How many holes are included between the sector arms?
9. How would you proceed to obtain the correct size across the flats when using a pair of straddle mills?
10. How would you proceed to make sure the head is central?

### OPERATION SHEET

#### Cutting a Spur Gear—24 Teeth, 10 Pitch

**Operations** (see Figs. 9-32*a* and 9-32*b*)

1. Press gear blank on mandrel, using an arbor press. Wipe a thin layer of white lead over mandrel to avoid scoring the bore of the gear blank.
2. Mount index centers on milling-machine table. Clean off all chips and burrs. Check head and tailstock centers for alignment before bolting them to table. Allow sufficient adjustment on footstock screw to insert and remove mandrel.
3. Mount milling cutter (10 pitch No. 5) on machine arbor. Align with center of index centers (approximately). Remove all chips and burrs from the faces of the collars.
4. Set index head for correct indexing.

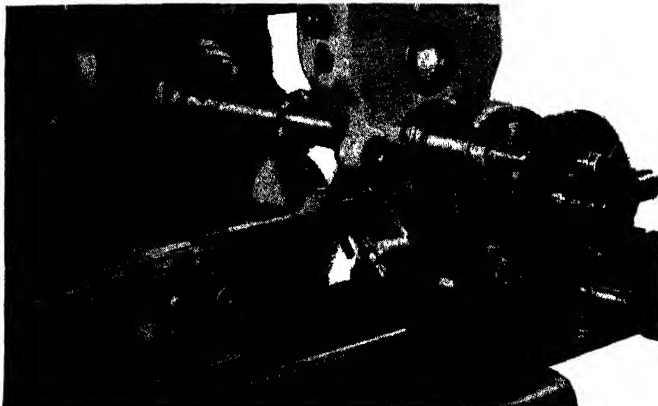
$$\frac{40}{N} = \frac{40}{24} = 1\frac{2}{3} \text{ turns}$$

$$\frac{2}{3} \times 1\frac{1}{11} = 2\frac{2}{33}$$

Indexing equals 1 turn and 22 holes on 33-hole circle.

**NOTE:** The 33 circle was selected because it is the outside circle on the plate. The longer leverage of the crank and the wider spacing of the holes will make the indexing operation easier.

5. Place dog on large end of mandrel and mount mandrel and job between centers with dog toward the headstock. White-lead the footstock end of the mandrel. Make sure that the tail of the dog has moving clearance in the slot of the work driver.



**Fig. 9-32a.** Cutting a spur gear in a Cincinnati milling machine (*The Cincinnati Milling Machine Company*)



**Fig. 9-32b.** Cutting a spur gear in a Brown & Sharpe milling machine (*The Brown & Sharpe Manufacturing Company*)

6. Clamp tail of dog with screw of work driver. While tightening the screw, see that the tail of the dog is not forced out of its normal position.
7. Centralize the cutter with the gear blank by placing the blade of a square tangent with the circumference of the blank and

measuring distance from the side of the cutter. Do the same on the other side of the gear blank and adjust until both sides measure the same.

8. Run the work under the cutter and raise the table until a piece of paper is torn between the revolving cutter and the blank.

*CAUTION:* Keep fingers on "up," or going-away, side of the cutter.

9. Allow 0.002 in. for paper thickness and set graduated collar on vertical adjustment at zero (0).
10. Move job clear of the cutter and raise the table to the depth of the roughing cut.

$$\text{Depth of tooth} = \frac{2.157}{P} = \frac{2.157}{10} = 0.2157 \text{ in.}$$

$$\text{Roughing cut} = 0.190 \text{ in.}$$

11. Rough out the first tooth and adjust the automatic feed trip.
12. Run the table back to starting position.
13. Index one turn 23 holes on 33 circle for the next tooth, and so on until all teeth are roughed out.
14. Raise the table to 0.216 in. (full depth) and take the finish cut for each tooth.

### QUESTIONS ON CUTTING A SPUR GEAR

1. If the gear blank is to be mounted on a mandrel for milling the teeth, why do you put white lead on the mandrel before forcing it into the hole?
2. Why must the index centers be in line?
3. How will you arrange the sector? Why?
4. In which direction do you turn the index handle? Why?
5. How do you select the proper cutter? What do the letters and figures stamped on the cutter indicate?
6. How is the cutter set approximately central by means of the dead center? By means of a square against the dead center?
7. How is the cutter set approximately central by cutting a very small spot on top of the blank and locating the cutter to line with the spot?
8. Why are screws provided to clamp the tail of the dog? Give reason.
9. How do you calculate the number of revolutions of the spindle to give the proper cutting speed for this job?



10. How much stock do you leave for a finishing cut?
11. How do you determine the depth of the cut to be made to give the correct tooth depth?
12. What is meant by a formed cutter? Is the gear cutter you are using a formed cutter?
13. What is a fly cutter? When is it advantageous to make and use a fly cutter? How is a fly cutter held?

**Fluting Reamers, Taps, Etc.** Standard cutting tools like drills, milling cutters, reamers, taps, counterbores, etc., can be purchased in the local hardware stores at less cost than they could be made in the average shop, because of the special facilities available in the tool-manufacturing industry. Nevertheless, there are occasions when special individual tools have to be made in the average machine shop. This means that the resourceful machinist is able to turn, mill, harden, temper, and grind these tools.

Reamers and taps are cut with special cutters. The operations incident to setting up the machine and taking the cut are substantially alike. The number of teeth and the width of the land depend upon the size and purpose of the given tool. If a blueprint is not furnished, possibly a standard tap or reamer of about the size called for is available for use as a model. Tables of sizes of all such tools are given in *American Machinists' Handbook*.

A double-angle cutter is best for fluting reamers, taps, end mills, etc., for the reason that both sides of the groove are then clean cut; that is, no part of the surface of the groove is scored by the dragging of chips. (This scoring often happens when a straight-faced single-angle mill is used, also when an end mill or a side mill is used for a facing cut.)

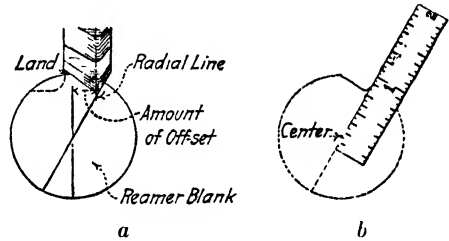
Most reamers are cut with the face of the teeth *radial*. To cut the groove with one side radial when using a double-angle cutter, it is, of course, necessary to offset the work laterally. The amount of offset depends on the number of teeth, the width of the land, and the shape of the cutter. Cutters vary in shape, and in many cases the "cut-and-try" method is preferred. If the cutter has a 30-deg. side, as in Fig. 9-33, the end layout may be used to advantage, especially by the beginner. In either case, judgment and care are necessary. *Study both methods*; they have many common features.

The beginner will find it rather difficult to set the cutter so that

when the face of the tooth is *radial*, the *land* is of the required width, and it will be advisable, for the first job at least, to use a practice piece of the same size as the reamer or the tap.

**Cut-and-try Method.** Apply blue-vitriol solution on the end of the blank and, using a center square and a sharp scribe, draw a radial line. Tighten a dog on the work, place on centers, and turn the index handle to line up the shorter edge of the cutter with the radial line, as shown in *a*, Fig. 9-33, for a trial cut. It is better to have the trial cut *somewhat less* than the proper depth for the reason that it may be necessary to index the work a trifle more, or to move the table laterally a trifle, or possibly both. Cut a short distance in the

**Fig. 9-33.** (*a*) Setting a reamer cutter. A radius is a straight line drawn from the center to the circumference. A radial tooth face will split the radial line. (*b*) Checking the radial face of a tooth.



first groove, run back, index to the next groove, and cut a short distance in that. Note if the cutter splits the line, and note also the width of the land. Assume that the line is split, giving a radial face to the tooth, but that the land is *too wide*. In this case it will be necessary to feed the table laterally, moving the radial line away from the cutter so that, when the table is raised for the deeper cut, the radial face of the tooth will be merely touched, not cut into. If the trial-cut tooth face is not parallel to or splitting the radial line, it will be necessary to “roll” (index) the work a little one way or the other.

To check the setup, stop the machine, remove the blank, and placing a scale against the tooth face, see if it is radial as in *b*, Fig. 9-33.

When the setting is correct, substitute the reamer for the trial piece. Remember that the cutter does not cut its full depth until the axis is over the end of the piece *A* (Fig. 9-34). Remember also to set the feed trip to operate when the axis is over the shoulder of the tap or reamer, as shown at *B*.

**Layout Method.** It may be easier, with cutters having a 30-deg. angle, to scribe two radial lines and index the first line until it is 30 deg. beyond the vertical, as shown in Fig. 9-35. In a study of the four steps given in Fig. 9-35 it will be observed (1) that the purpose of scribing the lines 45 deg. apart, as in *b*, is that there are eight teeth

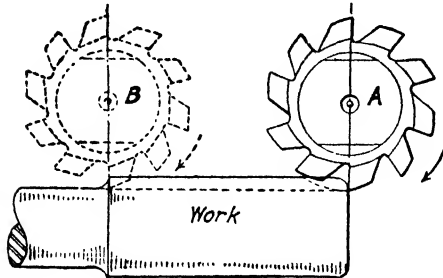


Fig. 9-34. *A*, cutting full depth of groove; *B*, end of cut. The feed trip should be set to operate when the axis of the cutter is directly over the shoulder.

in the reamer and the faces of the teeth are 45 deg. apart; (2) that *c* shows the second indexing step to get No. 1 line in a vertical position; (3) that indexing this line 30 deg. from the vertical, as in *d*, brings it in the correct relation to the 30-deg. side of the cutter; and (4) that the No. 2 line serves in *d* as a guideline to show the width of the land.

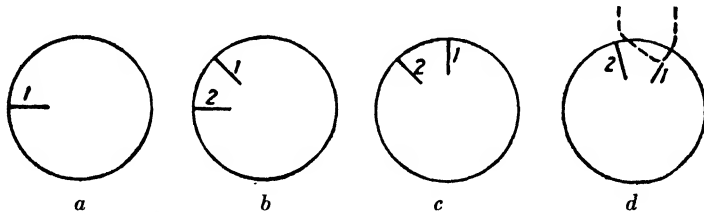


Fig. 9-35. Scribing lines for an eight-tooth reamer: (*a*) with the scriber of the surface gage set on center, scribe line No. 1; (*b*) index 5 turns for one tooth space, and scribe line No. 2; (*c*) index 5 turns to bring line 1 to a vertical position; (*d*) index  $3\frac{1}{3}$  turns (30 deg.) to bring line 1 to position for face of tooth, 30 deg. past vertical.

If there were, for example, six teeth in the reamer, the first indexing would be 60 deg. ( $6\frac{2}{3}$  turns), then 30 deg. ( $3\frac{1}{3}$  turns), to get the No. 1 line vertical, then 30 deg. ( $3\frac{1}{3}$  turns again), to get the No. 1 line in correct position for the 30-deg. side of the cutter.

**Unequal Spacing or Increment Cut.** When the teeth of a hand reamer are equally spaced, the tendency is for each tooth to cut a

trifle deeper than the preceding tooth, which produces a hole with a wavy surface—as many waves as there are teeth. Therefore, hand reamers are usually made with unequally spaced teeth.

The general rules to be observed for cutting reamers with unequally spaced teeth are:

Number of flutes must be even.

Faces of teeth must be opposite.

If *L* is the largest space between two teeth and *S* the smallest, and the smallest space follows the largest; then the difference between *L* and *S* should not be over 6 deg.

The number of teeth on Brown & Sharpe solid hand reamers are as follows:  $\frac{1}{8}$  in. to  $1\frac{7}{32}$  in.—(6);  $\frac{9}{16}$  in. to  $1\frac{3}{32}$  in.—(8);  $1\frac{1}{8}$  in. to  $1\frac{15}{32}$  in.—(10);  $1\frac{1}{2}$  in. to  $2\frac{1}{16}$  in.—(12);  $2\frac{1}{8}$  in. to  $2\frac{9}{16}$  in.—(14);  $2\frac{5}{8}$  in. to 3 in.—(16).

As an illustration of the operation, let it be required to cut a 1-in. reamer with eight teeth (Fig. 9-36). Assume the cutter is set to give a radial tooth of approximately the proper depth or a little less and that a 39 index circle is being used.

It will be advisable to start each successive reamer from the original position of the index handle; for example, cut the first flute in each reamer when the index pin is in the numbered hole in the circle. (Note in Fig. 9-36 that “8th index” will bring work to original position.)

Proceed as follows:

1. Cut the first flute.
2. Index 5 turns (1st index regular) and cut second flute.
3. Index 5 turns plus 15 holes (2d index) and cut (3).
4. Index (from the hole the pin is now in) 5 turns minus 10 holes (3d index) and cut (4).
5. Index (from the hole the pin is now in) 5 turns minus 5 holes (4th index) and cut (5).

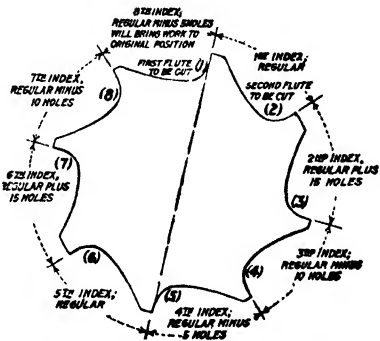
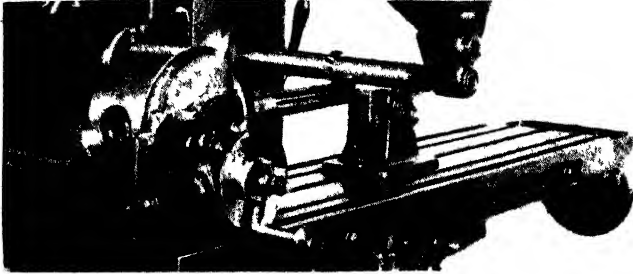
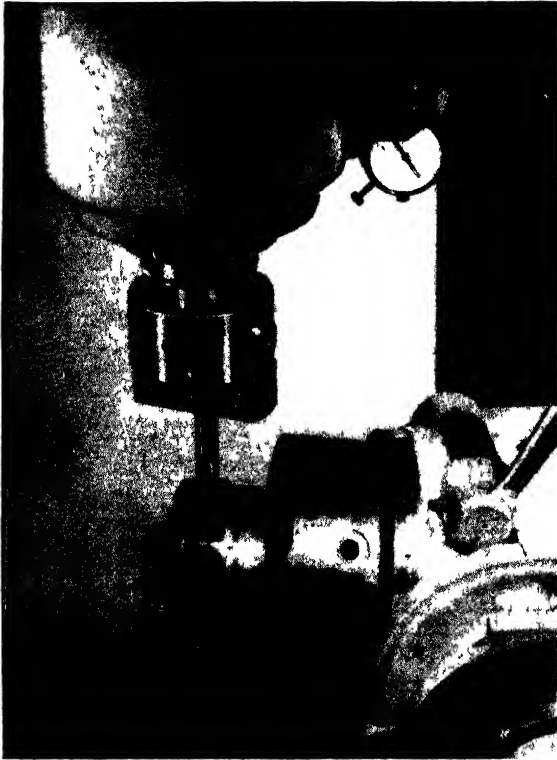


Fig. 9-36. Shows moves for unequal spacing of a reamer having eight teeth.



**Fig. 9-37.** Milling flutes in a taper reamer (*The Brown & Sharpe Manufacturing Company*)



**Fig. 9-38.** Boring operation using an adjustable boring head. (*The Kearney and Trecker Corporation*)

The fifth flute is now cut and the cutting face of (5) is exactly opposite the face of tooth (1).

The indexings for the teeth (6), (7), and (8) are duplicates of the movements 2d, 3d, and 4th, respectively, and the 8th index, which is a duplicate of the 5th, will bring the index handle to the original position.

Since opposite teeth are exactly opposite, many machinists prefer to cut a given tooth and then its opposite. Thus in Fig. 9-36, cut 1, then index 20 turns and cut 5; index for (6), cut 6, and index 20 turns and cut 2; index for (3) and cut 3; then 20 turns and cut 7, etc.

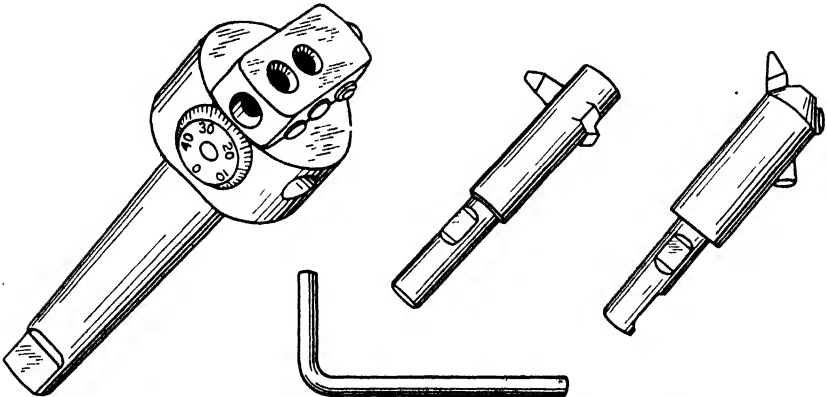


Fig. 9-39. Parts of an adjustable boring head. (C. C. Crayley Manufacturing Company)

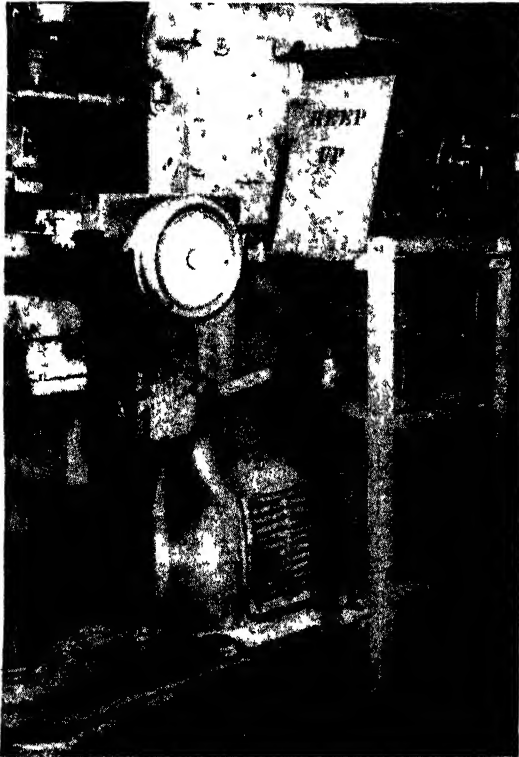
If the wider lands are too wide, lower the work a trifle and rotate the work to trim off the tooth, next trim opposite tooth; then arrange to trim back of another tooth and its opposite, etc. (see Fig. 9-37).

**Boring in the Milling Machine.** Boring may often be efficiently accomplished in a milling machine, especially in jig and fixture work (Fig. 9-38). The spacing between the holes may be obtained by means of the graduations on the feed screws, or the holes in the smaller circular jigs may be spaced by indexing.

Various adjustable boring toolholders or heads are manufactured (Fig. 9-39). They are made in several sizes. The material is hardened tool steel, and a high degree of accuracy is possible. The adjusting dial is graduated to 0.001 in. Such a toolholder may be provided

with a taper shank to fit the machine spindle or may be held in a chuck.

**Care of the Index Head.** The index head is a precision instrument, manufactured to extreme accuracy, and deserves the best of care in order that this accuracy may be preserved.



**Fig. 9-40.** The index head at "home base" when not in use (*James Anderson*)

Before it is mounted on the table, the base of the index head and the surface of the machine table should be wiped clean of oil and chips. All burrs should be carefully removed with a flat scraper or a smooth file.

**Hazards to Safety.** The safe worker will always stand on the "up," or *going-away*, side of the milling cutter and will use a *brush* to

free the cutter from chips. The action of the cutter must always tend to tighten the chuck onto the spindle of the headstock.

Accident statistics show that most accidents involving the use of the dividing head occur as the head is being lifted to and from the machine. Index heads are usually heavier than the average man can comfortably lift; therefore, a helper should assist in moving it from one place to another.

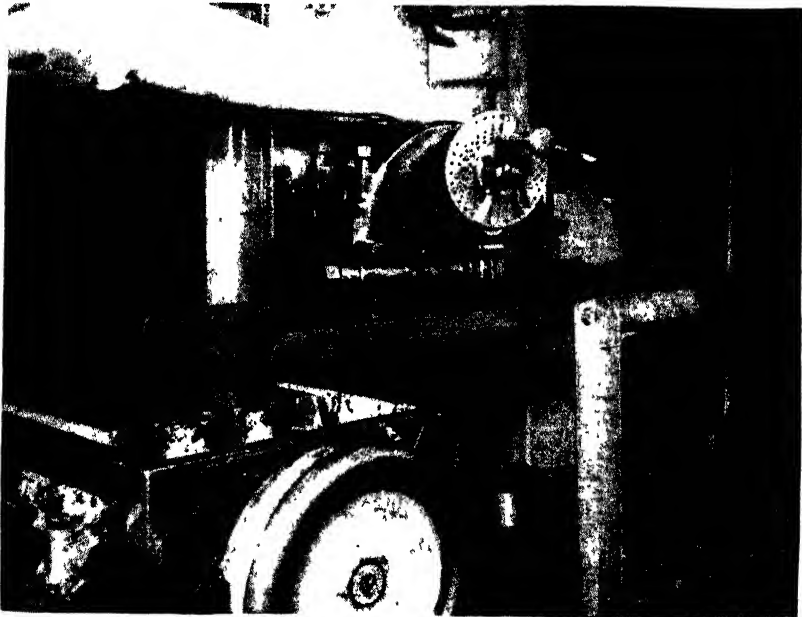


Fig. 9-41. The machine table lowered, the "gangplank" let down, and the index head slides across. (*James Anderson*)

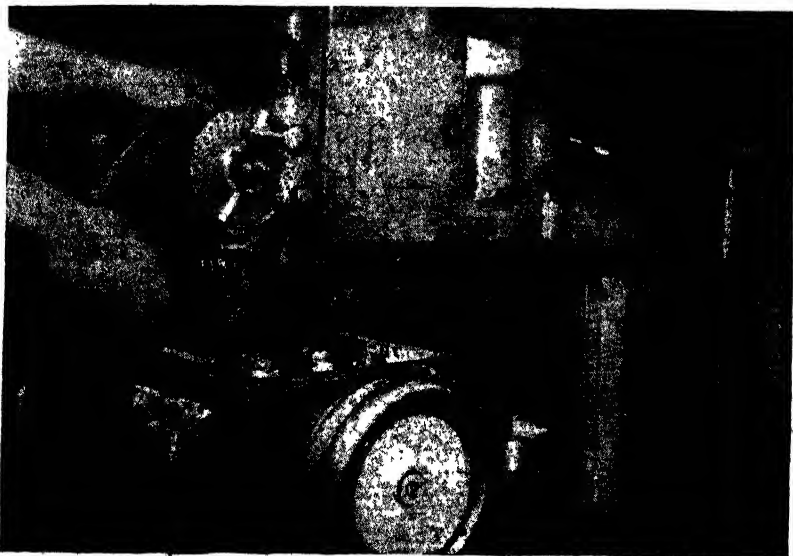
The table should be lowered as much as possible, preferably to waist height. The lifters should put both feet together, firm and flat on the floor, and close to the index head. Bending the knees and lowering the body, they should grip the index head firmly and raise it by straightening the knees, *keeping the back as nearly vertical as possible*. The index head should be raised by arm movement the balance of the distance required.

In some shops the index head is kept on a small wagon which can be wheeled to the table. The index head is transferred from the



wagon to the machine by being slid over. Care must be taken to keep the wagon close to the machine table. The operator must use his body and his feet to prevent the wagon from moving away from the table just as the index head is in mid-crossing.

Figure 9-40 shows a frame built to the side of the milling machine,



**Fig. 9-42.** The index head has been tilted, the base has been cleaned and is now being turned into its working position. (*James Anderson*)

on which is stored the index centers, chuck, steady rest, and the machine arbors. This frame prevents accidents caused by lifting the index head and minimizes the possibility of damage to the head itself.

When the use of the index head is required, the machine table is brought to the same level as the frame, the "gangplank" is unlatched and lowered. The index head is then slid across, as in Fig. 9-41.

As soon as it is on the table, the headstock can be tilted sufficiently to wipe the chips and oil from the base and can then be twisted into its working position, as in Fig. 9-42.

The headstock can be aligned by fitting the aligning tongues into the T slots and can be slid over into the required position on

the table. The "gangplank" can then be raised and latched (Fig. 9-43).

The operation is reversed in order to remove the heavy headstock from the table.

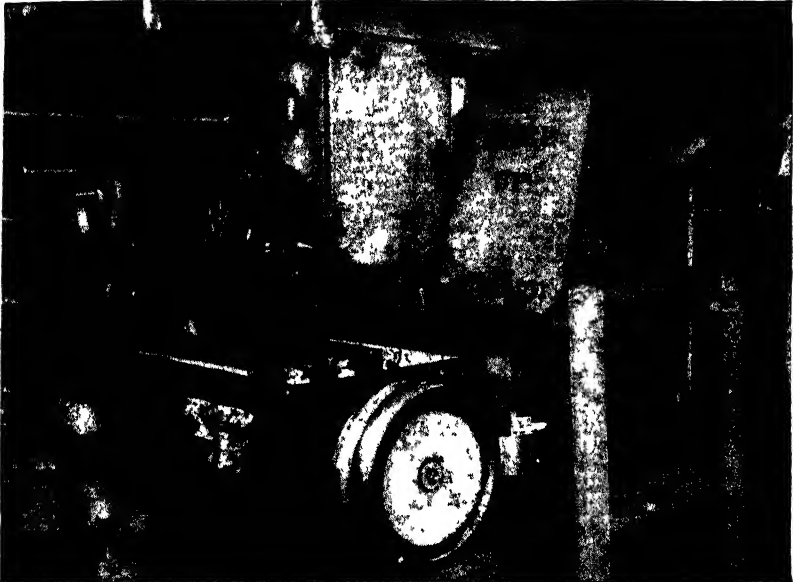


Fig. 9-43. The index head aligned by the fitting of the aligning tongues in the table T slots, and the "gangplank" is raised and latched. (*James Anderson*)

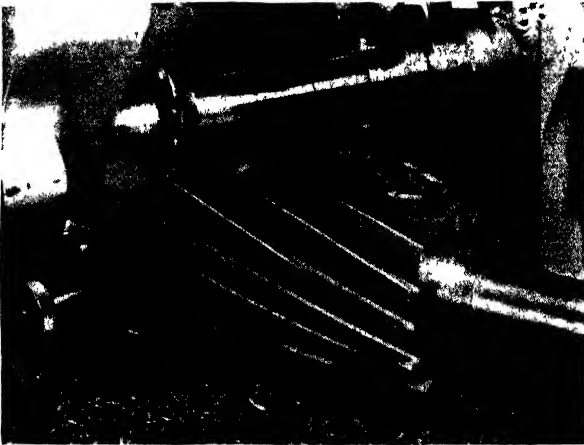
### QUESTIONS ON FLUTING TAPS AND REAMERS, BORING, ETC.

1. When may it be economical to make taps and reamers instead of buying them?
2. Why is an angular cutter inferior to a special double-angle cutter for fluting reamers?
3. Why is it necessary to offset the work from the center of the cutter?
4. When setting up, if the radial line of the layout is split, but the land is too wide, what corrections are made?
5. What is the advantage of an increment-cut reamer? Why are the teeth milled exactly opposite? Is this necessary in a taper reamer?

6. How may the index centers be adjusted to mill the flutes in a taper reamer?
7. Explain how one may do drilling, boring, and reaming in a milling machine.
8. What is the advantage of an adjustable boring toolholder?
9. How may the indexing device be used for feeding the work?
10. What precautions would you suggest to avoid the tendency of the chuck to loosen under the pressure of the cut?
11. Explain how you would remove the index head from the machine.

## Helical or Spiral Milling

Certain operations in machine-shop work seem to appeal to the student or the apprentice as being particularly interesting and worthwhile. One of them is cutting a thread in a lathe, and another is milling a spiral in a milling machine.



**Fig. 10-1.** Milling spiral-tooth milling cutter. (*The Cincinnati Milling Machine Company*)

There are points of similarity in cutting a thread and milling a spiral. When cutting a thread, the tool moves a certain distance while the work revolves once, and this distance is the lead of the thread and is governed by the “change gears” used. The same is true of milling a spiral, except that while the work is feeding against the cutter it is caused to revolve. The distance that it would have to

“feed” in order to make one complete revolution is the “lead” of the spiral.

While the lead of a thread is usually short in proportion to the diameter and the length of the thread, the lead of a spiral is usually long in proportion to the diameter and length (Fig. 10-1). For example, the lead of a  $\frac{7}{8}$ -in. diameter National Coarse thread is  $\frac{1}{9}$  in. (having nine threads per inch), and the lead of a standard  $\frac{7}{8}$ -in. counterbore (cutterhead about 1 in. long), cut with a spiral flute, is 10 in.

Setting up the machine for milling a spiral involves a knowledge of several mechanical principles. In the following pages the principles underlying the operation of spiral milling are first set forth as brief descriptions of the essential features. These features are then discussed in detail. To obtain a general survey of the subject, read through carefully and then, if possible, set up the machine and perform the operation, studying each paragraph until it is thoroughly understood.

### SPIRAL OR HELIX

The spiral is a line generated by the progressive rotation of a point around an axis. When the path of rotation is in a plane, it is called a *plane spiral*. A watch spring is an example of a plane spiral. If the convolutions of a spiral do not lie in a plane but form the shape of a cone, it is known as a *conical spiral*. If this line is wound around a cylinder, it is called a *helix*. The helical curve on a screw thread makes a number of complete turns within a comparatively short distance. The teeth of a spiral gear require only a small part of a complete turn; nevertheless, the tooth and the thread both are formed on a curve of the helix. The man in the shop seldom, if ever, speaks of cutting a helix; he knows it as a *spiral*. Spiral work includes the milling of spiral tooth-milling cutters, counterbores, twist drills, spiral gears, and cams with spiral grooves (Fig. 10-2).

In our discussion of the helix we will follow the common usage of the shop and call it a spiral.

**Lead of the Spiral.** The lead of a spiral is the distance it advances in one revolution measured parallel with its axis (Fig. 10-3). If gearing is so arranged as to cause the work to revolve once if it were fed 6 in., the lead of the spiral is 6 in. The length of the work or the

length of the cut taken makes no difference; that is, a lead of 6 in. to one turn may be cut on work 3 in. long, or a spiral with a lead of 6 in. may be cut 12 in. long. In the first case, the groove will go one half

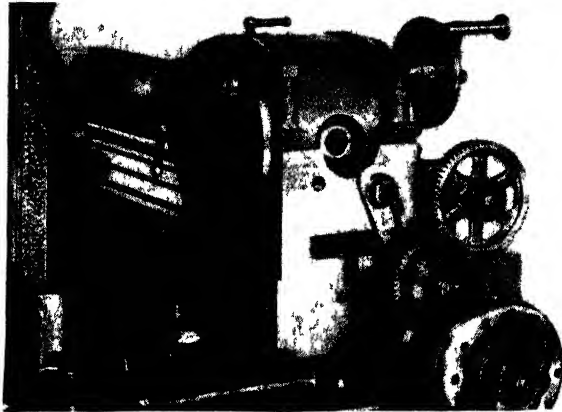


Fig. 10-2. Milling a steep spiral with an end mill (*The Brown & Sharpe Manufacturing Company*)

around the work; and in the second case, it will go twice around the work. The lead, however, is the same in both cases.

In most of the spirals cut in the milling machine the lead is more than 1 in., usually several inches; therefore spirals are designated in terms of "lead in inches to one turn" or merely "lead," as 1.5-in. lead, 24-in. lead, etc.

**Five Features of Spiral Milling.** 1. *Gearing.* Assume that a cutter is set to mill a groove in a cylinder and that, as the work is fed longitudinally under the cutter, it is at the same time given a uniform rotary movement. The groove will be a "spiral."

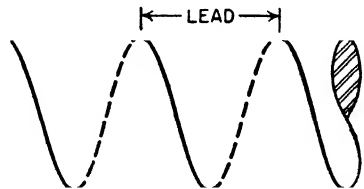
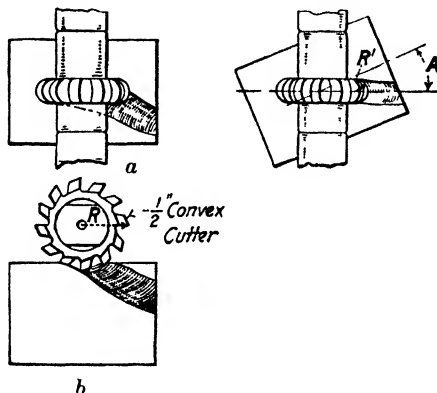


Fig. 10-3. The helical curve.

In order to mill a spiral, it is necessary to cause the work to rotate uniformly on its axis while it is being fed in the direction parallel to its axis. The design of the universal milling machine permits of obtaining these two movements, in practically any desired ratio to each other, by means of gearing from the table feed screw to the worm shaft of the index head,

similarly as threads of different leads may be cut in a lathe by using different change gears. The selection and arrangement of the change gears, as well as a description of the permanent gears in the index head, will presently be explained.

2. *Right-hand and Left-hand Spirals.* A spiral, like a thread, may be right-hand or left-hand, and the same definition applies. A right-hand thread or spiral turns or "twists" to the right as it advances; the left-hand spiral turns in the opposite direction (Fig. 10-19). An easy way of telling whether a thread or a spiral is right- or left-hand

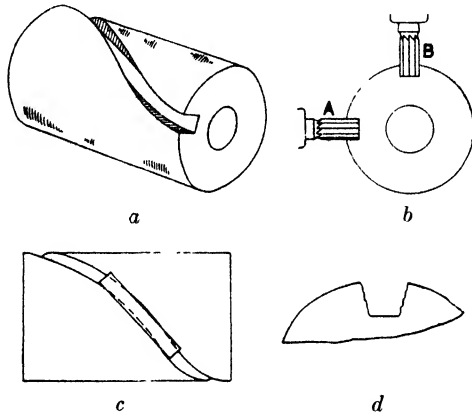


**Fig. 10-4.** (a) Top view and (b) front view of a spiral groove cut without swiveling the table. If the cutter is  $2\frac{1}{2}$  in. in diameter, the radius of the groove is about  $1\frac{1}{4}$  in., approximately equal to  $R$ , the radius of the cutter. Note in (c), which represents the top view with the table swiveled to the angle of the helix  $A$ , that the radius of the groove is  $\frac{1}{4}$  in., or equal to  $R'$ , the radius of the curve of the cutting edge.

is to hold it with the axis in a horizontal position and note the slant of the groove; if it slants *down* toward the right, it is right-hand; if down toward the left, it is left-hand. For example, observe that a twist drill has a right-hand spiral.

3. *Setting the Table.* If it is required to mill a  $\frac{1}{2}$ -in. semicircular spiral groove in a cylinder, a  $\frac{1}{2}$ -in. convex cutter may be used. If the cutter is set up with its axis at right angles to the axis of the work, as shown in *a*, Fig. 10-4, and the work is fed on a spiral, the groove, instead of having a  $\frac{1}{4}$ -in. radius will have a radius about equal to one-half the diameter of the cutter. This is shown in *b*, Fig. 10-4. In

order to mill this spiral groove the same contour as the cutting edge of the cutter it is necessary (1) to swivel the table of the machine to a certain required angle, or (2) to set the cutter to this angle, using the universal milling attachment. The relative positions of the cutter and the work in either case, (1) or (2), is illustrated in *c*. The angle is known as the angle of the helix (or spiral) and depends on *two* things: the *lead of the spiral* and the *circumference of the work*. How this angle is calculated will presently be explained.



**Fig. 10-5.** In (*a*) is shown a rectangular spiral groove, and (*b*) illustrates how this cut may be made with an end mill held horizontally, as at *A*, or in a vertical spindle, as at *B*. If it were attempted to mill such a groove with a narrow plain milling cutter or a slotting cutter as in (*c*), the groove when cut would not be rectangular but would appear about as shown somewhat enlarged at (*d*).

4. *The Shape of the Cutter.* Figure 10-5, *a*, represents a spiral groove with parallel sides, milled in a cylinder. This groove may be cut horizontally or vertically with an end mill or a cotter mill as shown at *b*, but it will be impossible to produce such a groove of rectangular shape with a regular slotting cutter, because a cutter with parallel sides cannot fit into a curved slot. This is illustrated in *c*. The effect of attempting to use such a cutter for spiral milling is shown in *d*; the sides of the slot will be ragged and the shape of the slot will not be rectangular. Further, an angle cutter with a straight side should not be used to cut spiral flutes, for the reason that the teeth on the



straight side will not produce a clean, smooth cut but will have an effect similar to that shown in *d* (Fig. 10-5).

It is, however, entirely feasible to use a cutter mounted on the arbor to mill a spiral groove, provided that the side-cutting edges incline more or less toward each other; for example, a double-angle cutter, or a convex cutter, or a gear-tooth cutter may be used to cut a spiral, because no part of the cutting edge of any tooth of such a cutter touches the work except when it is taking a chip (Fig. 10-18, page 325).

5. *Circular Pitch and Normal Pitch.* The section (or shape) of a groove generated, or of the tooth formed, by spiral milling is *normal* (that is, of true form), only when viewed (measured) at right angles to the direction of the groove or tooth. The section of either as seen or measured on the end of the work is distorted; that is, the groove

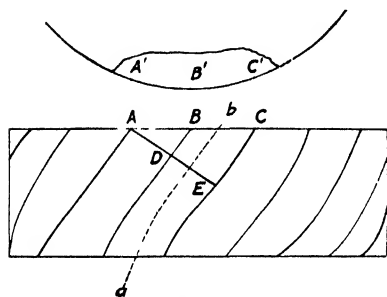


Fig. 10-6.

appears and is unlike the form of the cutter, and the tooth shape is correspondingly distorted when viewed at right angles to the axis of the work. This difference is shown graphically in Fig. 10-6, where *ABC* represents the circular pitch of a spiral gear, *AB* the tooth, and *BC* the tooth space. The dotted line *ab* shows the direction of the groove, and the line *ADE*,

at right angles to the side of the tooth at *A*, represents the normal pitch of the gear. It is obvious that the width of the groove as viewed on the end *BC* is greater than the width as viewed at *DE*, and the depth being the same in both places the shapes are unlike. This feature is of extreme importance when milling spiral gears and must sometimes be considered when judging or gaging the shape of other spiral teeth or grooves.

## QUESTIONS ON SPIRAL MILLING I

1. What do you understand by the term *spiral*? Is a thread a spiral?
2. What are the points of similarity of a thread and a spiral?

3. What is the chief difference between the helical groove of a thread and the helical groove of a spiral-milling cutter?
4. What is meant by the lead of a spiral? How is this distance measured and expressed?
5. Why is it necessary, when milling a spiral, to cause the work to revolve slowly at the same time it is being fed?
6. How is the work caused to revolve while it is being fed?
7. Assuming that the work revolves once as it is fed 10 in., what requires changing in order to give a lead of 20 in.?
8. How is the table of the milling machine set at an angle?
9. Why is it necessary to set the table at an angle when milling spirals?
10. State a simple method of determining a right-hand spiral from a left-hand spiral.
11. Give the reason why a regular slotting cutter cannot be used to cut a spiral groove of rectangular shape.
12. Is the angle of the flute or groove as measured on the end of a spiral-milling cutter exactly the same as the angle of the cutter that produced it?

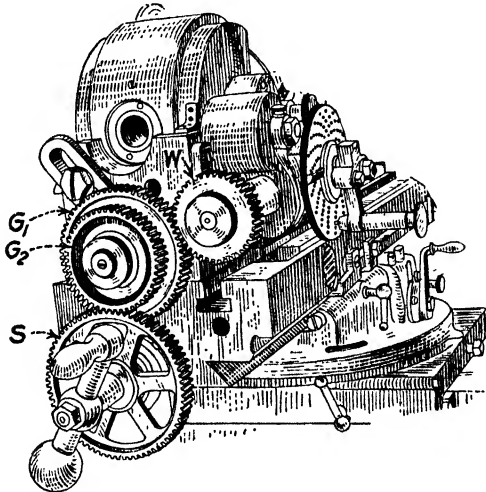
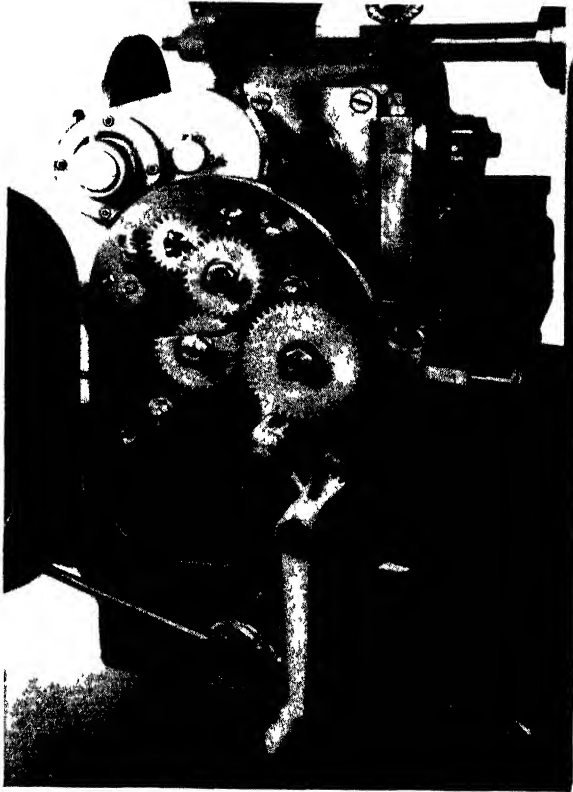


Fig. 10-7. Brown & Sharpe index head arranged for spiral milling.

**Gears Necessary for Spiral Milling.** Figures 10-7 and 10-8 show, respectively, a Brown & Sharpe index head and a Cincinnati index arranged for spiral milling. Both pictures show that there is a train of spur gears connecting the table feed screw to the index head.

Motion or movement is transmitted through this gearing, the rates of which will determine the amount of the lead. Lead, when used in connection with spirals, refers to the distance traveled in a straight line to make one complete turn. Before learning how to calculate the



**Fig. 10-8.** Cincinnati index head arranged for milling a right-hand spiral or helix. Leads from  $2\frac{1}{2}$  in. to 107 in. are possible with this mechanism. (*The Cincinnati Milling Machine Company*)

sizes of these gears for the various "leads" of the spirals, it will be best to determine how the gears *within* the index head operate to transmit motion from the worm gear and the spindle.

**Spiral-head Gearing.** The principle governing the construction of the Universal Spiral Index Head is the same for any standard

make. The purpose is to cause the worm shaft (and consequently the work) to turn by power-driven gearing, without interfering with the regular functions of the dividing head.<sup>1</sup>

To obtain this power movement, the index-head plate is caused to turn. It is therefore necessary to disengage the locking pin when one is setting up for spiral milling. For cutting spirals, only plain indexing can be used.

Because the shaft on which the worm gear is mounted *W* (Fig. 10-9) is at right angles to the worm shaft, the use of either bevel

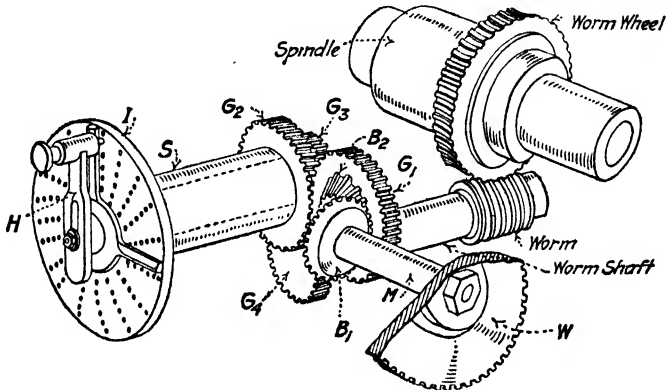


Fig. 10-9. Spiral-head gearing (Cincinnati). Motion transmitted from *W* through *M* to *B*<sub>1</sub> to *B*<sub>2</sub> to *G*<sub>1</sub> to *G*<sub>2</sub>, through shaft within *S* to *G*<sub>3</sub> to *G*<sub>4</sub>, through worm shaft, worm, and worm wheel to spindle and work.

gears or spiral gears is necessary to transmit motion from the one to the other.

**Index Head with Bevel Gears.** The way in which *bevel* gears may be employed is illustrated in Fig. 10-9. Motion of the gear *W* causes motion of the miter gear *B*<sub>1</sub>, both being keyed to the shaft *M*; *B*<sub>1</sub> engages *B*<sub>2</sub> which is fastened to *G*<sub>1</sub>; the gear *G*<sub>1</sub> engages *G*<sub>2</sub> which is fastened to the sleeve *S*, to which is also fastened the index plate *I*; consequently, when the gears are in motion the index plate revolves. The index crank *H* and the gear *G*<sub>3</sub> are fastened to the same shaft; therefore if the index pin is in a hole in the plate and moves with the

<sup>1</sup> Index head, spiral head, and dividing head are used in different places to mean the same thing. The universal spiral index head is an index head, or dividing head, which may be used for cutting spirals.

plate the gear  $G_3$  moves. The gear  $G_3$  engages  $G_4$ , which is keyed to the worm shaft and thus transmits motion to the worm and the worm wheel. It will be observed that the pairs of gears  $B_1$  and  $B_2$ ,  $G_1$  and  $G_2$ , also  $G_3$  and  $G_4$ , are equal; therefore 40 turns of the auxiliary shaft  $M$  will cause one turn of the worm wheel.

Ordinarily, for indexing, only the gears  $G_3$  and  $G_4$  are used; the index plate is held in position by a stop and does not turn. When the index crank is turned, its shaft turns freely through the sleeve  $S$ ,

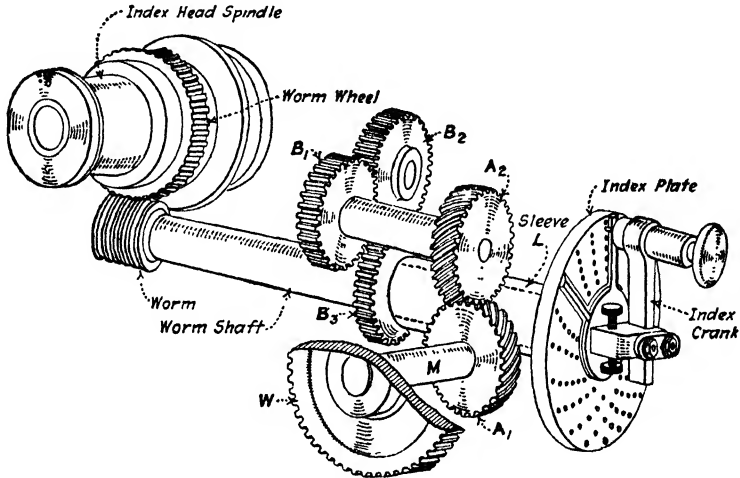


Fig. 10-10. Spiral-head gearing (Brown & Sharpe). Motion transmitted from  $W$  through  $M$  to  $A_1$  to  $A_2$  to  $B_1$  and  $B_2$  (idler) to  $B_3$ , through sleeve  $L$  to index plate to index crank to worm shaft, worm, worm wheel, spindle, and work.

moving the gears  $G_3$  and  $G_4$  and causing the worm and the worm wheel to move, thus indexing the work the required amount.

**Index Head with Spiral Gears.** In the cut (Fig. 10-10) is shown the arrangement of the gearing in an index head in which *spiral gears* are used to transmit the motion at right angles. The construction of the head is more compact than the cut indicates. This cut has been made with the idea of showing the arrangement more clearly.

Motion of the gear  $W$  on the shaft  $M$  is transmitted to the spiral gear  $A_1$  to the other spiral gear  $A_2$  to spur gear  $B_1$  to intermediate  $B_2$  to  $B_3$ . The gear  $B_3$  and the index plate are fastened to the sleeve  $L$ . Therefore, when  $B_3$  revolves, the index plate revolves and, when the

index pin is in, the index crank is carried around with the plate; and since the index crank is fastened to the worm shaft, this operates the worm and the worm wheel. Remember when setting up that the *stop pin* must be withdrawn.

In the above arrangement, it will be noted that simple indexing of the piece being milled on a spiral is accomplished in the usual way. (Pull out the index pin, turn the index handle, and the worm shaft turns in the sleeve  $L$  and causes the work to turn the required part of a revolution, entirely independent of the gearing for the spiral.) The idler gear  $B_2$  is in the swivel center of the head, and tilting the head in no way affects the engagement of the gears. The gears all have the same number of teeth, so that 40 turns of  $W$  will cause one turn of the worm wheel.

In connection with a study of the gearing, which may be regarded as a permanent part of the index-head mechanism, there are three outstanding features:

1. The operation of indexing is entirely independent of the spiral mechanism. For example, after one groove of a spiral mill is cut the table is run back and the work indexed in the usual way for the next groove.

2. The arrangement of the gears in the head is such that when not in use they in no way interfere with tilting the head, or with either simple or direct indexing.

3. One turn of the auxiliary shaft on which the gear  $W$  is mounted causes one turn of the wormshaft and  $\frac{1}{40}$  of a turn of the work; in other words, the operation is exactly the same as if the gear  $W$  were mounted direct on the worm shaft, and in any discussion of the mechanism and in the calculations for the change gears for cutting any spiral, the gear  $W$  is spoken of as the "gear on worm."

**Change Gears for Spiral Milling.** In Fig. 10-7 the gear  $S$  known as the *gear on screw* is keyed to the feed screw.  $G_1$  and  $G_2$  are respectively *first gear on stud* and *second gear on stud* (or first intermediate and second intermediate). They are both keyed to a sleeve, which rotates freely on a stud, which is fastened in an adjustable bracket; and they form the compound between  $S$ , the gear on screw, and  $W$ , which in spiral milling is known as the *gear on worm*.

Thus a movement of the feed screw, besides causing the table to feed, may cause the work to revolve if gears are arranged to transmit

motion from the feed screw to the worm shaft. The gears  $S$ ,  $G_1$ ,  $G_2$ , and  $W$  are the change gears. Twelve change gears are regularly furnished, and by the use of different combinations of gears, the ratio of the rotary movement of the work to the longitudinal movement of the table can be varied, and spirals of various leads may be cut. Introducing an idler serves to change the direction of the driven gear, consequently spirals may be either right-hand or left-hand.

The manner of arranging the change gears for spiral milling on the Brown & Sharpe milling machine is indicated in Fig. 10-11; *a* shows the arrangement when no idler is used, and *b*, when an idler is used.

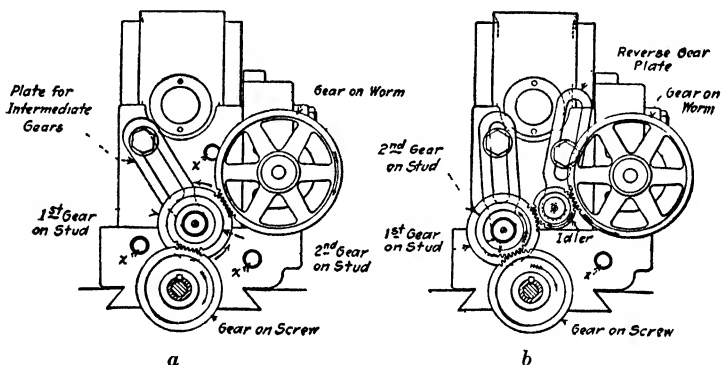


Fig. 10-11. Brown & Sharpe change gears arranged (*a*) for right-hand spiral, and (*b*) with idler introduced for cutting left-hand spiral

It will be noted that the gears on the stud and also the idler gear are mounted on adjustable brackets. Tapped holes ( $x$ ) are provided in the back of the index head and in the end of the table for the cap screws used for holding these brackets.

It will be observed that, when four change gears make up a compound gear train, two are driving gears and two are driven gears. Compound gearing is used for spiral milling because it makes possible a wider range of lead distance. It also makes possible, by combinations, the use of smaller gears, enabling the use of gear ratios that would prove impracticable in simple gearing. The center distance necessary for the use of simple gearing could not be fitted into the available space. The idler is neither a driving gear nor a driven gear. It is used to change the direction of the gears which follow it in the train.

**Calculating the Gears for Spiral Milling.** The lead of the milling machine can be found by placing gears that have the same number of teeth on the feed screws and the worm shaft. The gears can be connected with idlers. Forty turns of the feed screw will turn the worm shaft 40 times, which will revolve the index-head spindle once. Since the feed screw revolves 40 times, the table will move 10 inches. (Most milling machines have a  $\frac{1}{4}$ -in. feed screw, four threads per inch, 40 revolutions of the feed screw will feed the table  $40 \times \frac{1}{4}$  in., equaling 10 in. In spiral milling this distance is known as the *lead of the machine*.)

In spiral milling, the formula for calculating the gears to cut any spiral is similar to the formula for calculating the gears for thread cutting in a lathe, the constant in spirals being the "lead of the machine." The formula may be expressed as a proportion thus: the lead of the machine is to the lead of the spiral required as the product of the driving gears is to the product of the driven gears. Expressing the ratios as fractions:

$$\frac{\text{Lead of machine}}{\text{Lead of spiral desired}} = \frac{\text{driving gears}}{\text{driven gears}}$$

To illustrate the calculations two examples are given:

EXAMPLE 1: Spiral with a lead of 12 in. required.

Using the formula and substituting values

$$\frac{\text{Lead of machine (10)}}{\text{Lead of spiral required (12)}} = \frac{\text{driving gears}}{\text{driven gears}}$$

That is,

$$\text{The fraction } \frac{10}{12} = \text{ratio } \frac{\text{driving gears}}{\text{driven gears}}$$

Now if a simple gear train (one driving and one driven gear) were to be used and a 10-tooth gear for the screw and a 12-tooth gear for the worm were available, such an arrangement could be used. However, no such gears are at hand, and further, it is desired in this example to use four gears as a compound gear train because in most cases, if not in this, a compound gear train is advisable.

In order to select these gears, the fraction  $\frac{10}{12}$  is split into two fractions whose product equals  $\frac{10}{12}$ , for example  $\frac{5}{4} \times \frac{2}{3}$ , the terms of which will represent the two pairs of change gears.



If it were possible to obtain and use gears with 5 teeth and 2 teeth, they would be the driving gears and the 4-tooth and 3-tooth gears would be the driven gears. Of course, this is impossible; therefore both the numerator and the denominator of either fraction ( $\frac{5}{4}$  and  $\frac{2}{3}$ ) are multiplied by any number, whole or mixed,<sup>2</sup> that will give a numerator and a denominator that correspond to the numbers of the teeth on two of the available change gears.

Thus, multiplying both the numerator and denominator of the first fraction  $\frac{5}{4}$  by 8 for trial, and of the second fraction  $\frac{2}{3}$  by 24 for trial gives

$$\frac{5 \times 8}{4 \times 8} = \frac{40}{32} \quad \text{and} \quad \frac{2 \times 24}{3 \times 24} = \frac{48}{72}$$

or

$$\frac{5 \times 2}{4 \times 3} = \frac{40 \times 48}{32 \times 72} = \frac{\text{driving gears}}{\text{driven gears}}$$

That is, gears 40 and 48 may be used for the driving gears and 32 and 72 for the driven gears.

These gears may be arranged in the B. & S. machine, for example, as:

72 gear on worm (driven gear)  
 40 first gear on stud (driving gear)  
 32 second gear on stud (driven gear)  
 48 gear on screw (driving gear)

Or they may be arranged otherwise *if* the driving gears are arranged to drive and the driven gears are arranged to follow.

EXAMPLE 2: Spiral of 27-in. lead required.

$$\frac{\text{Lead of machine (10)}}{\text{Lead of spiral desired (27)}} = \frac{\text{driving gears}}{\text{driven gears}}$$

$$\frac{10}{27} = \frac{2 \times 5}{3 \times 9} = \frac{32 \times 40}{48 \times 72}$$

72 gear on worm (driven gear)  
 32 first gear on stud (driving gear)  
 48 second gear on stud (driven gear)  
 40 gear on screw (driving gear)

<sup>2</sup> Multiplying both the numerator and denominator of a fraction by the same number does not change the value of the fraction.

*NOTE:* Remember, when using the above formula, that the gear on the screw is the initial *driving gear*.

As a matter of fact, from a practical standpoint, the cards furnished with the machine will show the gears to use and the angles to set the table for a great variety of spirals. Further, all leads possible with the combinations of gears that may be used have been calculated and published by Brown & Sharpe Manufacturing Company and also by the Cincinnati Milling Machine Company. However, the man who is always satisfied to let someone else do his thinking for him is always cheap help. What would he do if one of the gears were lost or broken?

**Angle of the Helix or Spiral.** As previously stated on page 305, in order to cut a spiral otherwise than with an end mill, it is necessary to set the table or the cutter to a certain angle, that is, to the angle of the helix (or spiral) being cut.

The development of a spiral—in other words, the path of the spiral—may be represented by the path of the hypotenuse of a paper right-angle triangle (Fig. 10-12), when wound about a cylinder as shown. The adjacent sides *L* and *C* must equal respectively the *lead* of the spiral and the *circumference* of the cylinder, and the side *L* is parallel to the axis of the cylinder. The angle included between the sides *H* and *L* is the angle of the spiral and this is the angle to which the table must be set, or if the universal milling attachment is used, the angle to which the cutter must be set.

*C* - Circumference of Cylinder.  
*L* - Lead of Spiral.  
*H* - Hypotenuse.  
*a* - Angle of Spiral  
 $C = L \tan a$

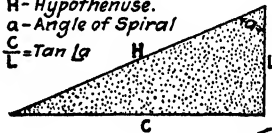


Fig. 10-12.

The angle of the spiral may be ascertained in two ways. By the first method it is found graphically, that is, by making a drawing of a right triangle similar to that shown in Fig. 10-12, *L* being equal to the lead, and *C* equal to the circumference of the work. The angle *a* may be measured with a protractor.

The second method, which is more accurate and often more convenient, involves mathematical calculations and the use of a table of tangents.

The calculations for the parts of a helix (or "spiral") are made

with the use of trigonometric tables.<sup>3</sup> In the right triangle, Fig. 10-12, the circumference of the cylinder corresponds to the *side opposite* the angle, and the lead corresponds to the *side adjacent* to the angle. Hence the following rules:

**RULE 1** To find the angle of the spiral having given the circumference of work (pitch circumference in spiral gears) and the lead:

Circumference divided by lead equals the tangent of the spiral angle or

$$\frac{C}{L} = \tan \text{angle } a$$

**EXAMPLE** Diameter of blank = 3 in. (*circumference* equals 9.42); lead = 24 in. What is the angle of the spiral?

**SOLUTION**  $\frac{9.42}{24} = 0.392 = \tan 21^{\circ}25'$ , or  $21\frac{1}{2}^{\circ}$  (near enough)

**RULE 2:** To find the lead having given the circumference of blank and the spiral angle: Divide the circumference by the tangent of the angle, or

$$L = \frac{C}{\tan \text{angle } a}$$

**Fig. 10-13.** Left-hand helical or spiral gears, 45-deg spiral angle.

angle of spiral equals 26 deg. What is the lead?

**SOLUTION:** Tangent of angle of 26 deg. equals 0.488. Dividing circumference 10.90 by 0.488 equals 22.5, or lead equals  $22\frac{1}{2}$  in.

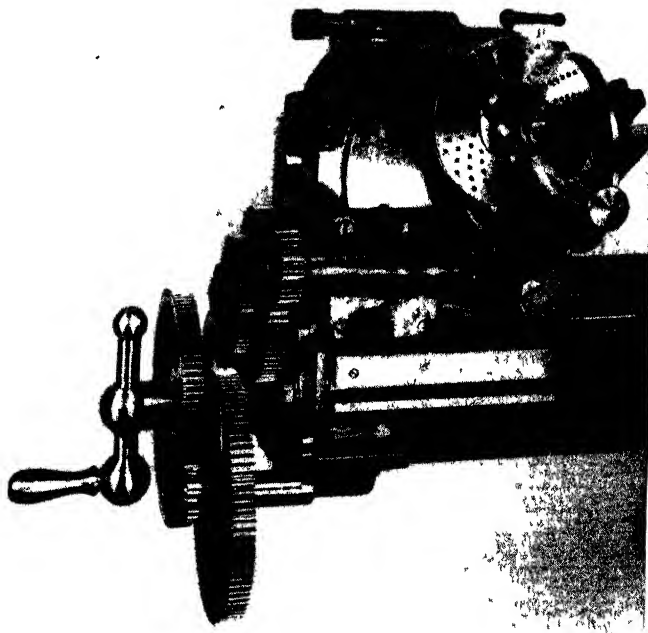
*Setting the Table for Right-hand and Left-hand Spiral.* For a *right-hand spiral* move the zero line on the swivel plate to the right of the

<sup>3</sup> For formulas and tables, see pages 651 to 666. For explanation of shop trigonometry, problems, etc. refer to Aaron Axelrod, *Machine Shop Mathematics*, 2d ed., pp. 160-182 McGraw-Hill Book Company, Inc., New York, 1951.

zero line on the saddle; move it in the opposite direction for a *left-hand spiral*.

### MILLING STEEP SPIRALS

There are many instances when it is required to mill steep-angle spirals, or, as they are also called, *short-lead spirals*. Figure 10-13

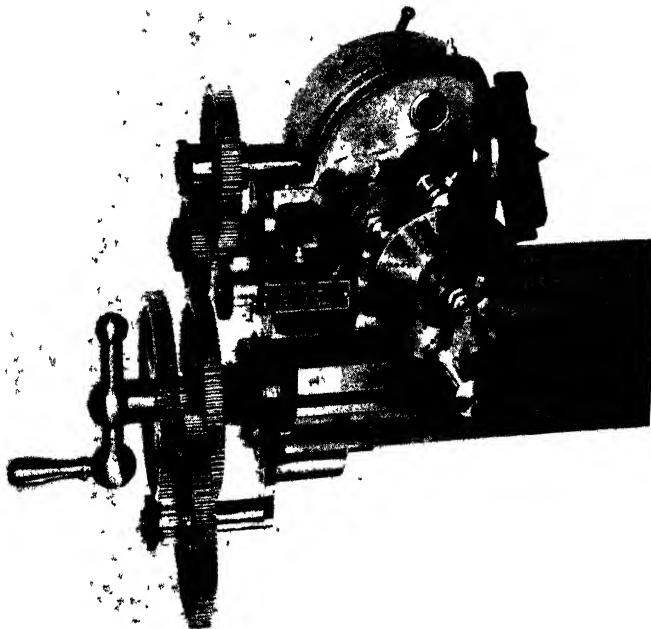


**Fig. 10-14.** Number 0 short lead and feed-reducing attachment. The drive is connected to worm. (*The Brown & Sharpe Manufacturing Company*)

shows a pair of mating spiral gears. The angle of the spiral teeth is 45 deg. and the lead of the teeth is very short. This makes it necessary for the index-head spindle to revolve while the table moves a comparatively short distance. This places excessive strain upon the gears and the mechanism, and it is found impracticable to cut steep spirals by the method previously outlined. The Brown and Sharpe Company manufacture a short-lead and feed-reducing attachment

(Fig. 10-14), which consists of nine spur gears and a mounting bracket, together with setup data, gearing diagrams, and formulas. Leads of 0.150 in. and higher are obtained by gearing to the headstock worm, as illustrated in Fig. 10-14.

Figure 10-15 shows the Brown and Sharpe attachment set up to cut very short leads. It can be observed that this method of gearing bypasses the regular indexing mechanism; the differential indexing



**Fig. 10-15.** The short-lead and feed-reducing attachment. The drive is connected to the differential spindle. (*The Brown & Sharpe Manufacturing Company*)

center is used and gives leads  $\frac{1}{800}$  of those normally obtained with a given gear train.

**Short- and Long-lead Attachment.** The attachment shown in Fig. 10-16 is the Cincinnati short- and long-lead attachment, manufactured by the Cincinnati Milling Machine Company as an attachment for its dividing head. The gears can be arranged as either a simple or a compound gear train.

The ball crank is used only to test the setup and is then removed so that the door can be closed for safe operation. Figure 10-17 shows the attachment closed and ready for use. By moving the two lower levers to the various positions it is possible to obtain five different

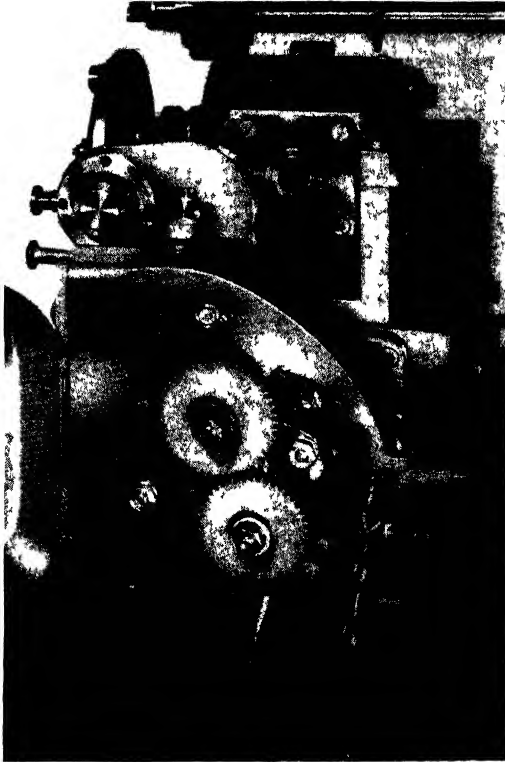


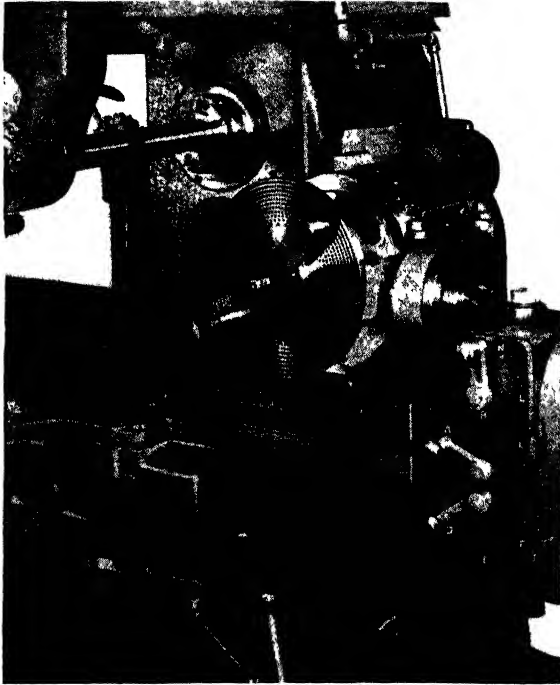
Fig. 10-16. The driving mechanism for the Cincinnati long and short-lead attachment. Lead range is 0.010 in. to 1,000 in. (*The Cincinnati Milling Machine Company*)

leads with each combination of change gears. In this way 13,720 different leads can be obtained, from .010 to 1,000 in.

The spiral can be cut on either the right or the left hand by means of the small lever shown near the top of the attachment housing.

**Using the Card Furnished with the Machine.** (Card marked, "Table of Approximate Angle for Cutting Spirals" or "Table of Change Gears, Angles, and Leads for Cutting Spirals.")

1. To find the *gears* to use: In the column marked "Lead in inches" find the required lead, and in line with the lead, the four gears that will give this lead are shown. The position of each gear is shown at the top of its column—as "gear on worm," "first gear on stud," "second gear on stud," and "gear on screw."



**Fig. 10-17.** Long- and short-lead attachment showing levers necessary to produce five series of leads. (*The Cincinnati Milling Machine Company*)

2. To find the *angle* at which to set the table: Near the top of the card under the heading "Diameter of Work" or "Diameter of Cutter, Drill, or Mill" are several columns captioned by figures representing various diameters from  $\frac{1}{8}$  to 6 in. In these vertical columns are figures representing the various angles to which the table must be swiveled to give the proper setting of a particular diameter of work for any spiral. The number of degrees the table

must be swiveled is found where the horizontal column to the right of the "lead" meets the vertical column under the "diameter."

EXAMPLE: Work,  $2\frac{1}{2}$  in. in diameter; lead, 22.50.

1. Find under "lead in inches to one turn" 22.50. In the same line are four gears; 72, gear on worm; 28, first gear on stud; 56, second gear on stud; 64, gear on screw.

2. Lay a card or a rule just under the horizontal column of figures to the right of the lead 22.50, then follow down column under  $2\frac{1}{2}$  diameter until the figure opposite 22.50 is reached, and find that the table should be set about  $19\frac{1}{4}$  deg.

### QUESTIONS ON SPIRAL MILLING II

1. What is the purpose of the "change gears" in spiral milling? How many are there?
2. What do you understand by "the spiral-head gearing?"
3. Why are either bevel gears or spiral gears used in the spiral-head gearing?
4. Why is it necessary to withdraw the stop pin or disengage the index-plate locking device, whatever it may be, when cutting a spiral?
5. Make a sketch which will show the way in which motion is transmitted from the table-feed screw to the spiral-head spindle.
6. Set up the machine for any convenient lead of spiral. In the change gear train, which is the initial driving gear? Is there a compound of two gears used? Is an idler used? Which is the final driven gear?
7. As for the setup in the preceding question, divide 10 times the product of the driven gears by the product of the driving gears. What is the answer equal to?
8. If it were possible to transpose the driving gears and still get the proper engagement of gears in the train, would this change the spiral? Explain.
9. Suppose the card furnished with the machine calls for certain gears to cut a given lead and one of the gears is lost, what could you do?
10. The card furnished with Brown and Sharpe milling machine calls for the gears 56, 32, 40, and 100 to cut a lead of 7 in. The gears 56, 40, 32, and 64, if properly arranged, may be used? How should they be arranged?
11. In the first case (question 10), 32 is a driving gear and 40 is a driven gear. Is this true in the second case? Explain.
12. On the card furnished with Brown and Sharpe milling machine, the angle of the spiral for a lead of 7 in. on work 1 in. in diameter is given as



- 24½ deg., and for work 2 in. in diameter the angle is 12 deg. Cut out triangles as explained in paragraph 255 and check results.
13. Cut out a triangle to show the angle of the spiral for a lead of ¼ in. on work 2 in. in diameter. How does this angle compare with the angle for work of the same diameter but half the lead (question 12)?
  14. State the *two* things that determine the angle of the spiral.
  15. Frequently a certain angle of spiral is required on a given diameter. How would you find the lead? How would you calculate the gears to use?

### OPERATIONS OF CUTTING A SPIRAL

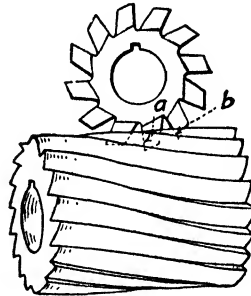
**Example Selected: Spiral-milling Cutter.** Operations in spiral milling which are not uncommon in most machine shops and which offer excellent practice are cutting the flutes in spiral-milling cutters, spiral end mills, and counterbores. These operations involve less mathematics than cutting either cams or spiral gears, but they do require the same knowledge of spiral milling and as much if not more skill in the setup.

The reason that the setup for cutting a spiral mill is more difficult is because the flute is not symmetrical, as is the cam groove or the gear-tooth space. To set the cutter for a spiral gear, for example, it is only necessary to set the cutter central with the blank before swiveling the table to the required angle, while to set a double-angle cutter to produce either a radial tooth, as is usually required on finishing cutters, or a tooth with 10- or 15-deg. rake for roughing cutters, it is necessary to offset the work under the cutter a certain distance. Since the distance the work is offset depends on (1) the angle of the cutter, (2) the diameter of the blank, (3) the number of teeth, and (4) whether a radial tooth face or an undercut tooth face is required, no set rule for the offset can be given. It is best to lay out lines indicating the faces of two adjacent teeth and proceed carefully to cut to the layout.

**Reason for Double-angle Cutters.** When an angular shaped groove is desired, as in a spiral-milling cutter, it is impossible to produce a radial tooth or a smooth surface with an angular cutter because such a cutter has one straight side and will act in a way similar to the cutter *c* in Fig. 10-5. A double-angle cutter should be used. The groove clearance of a double-angle cutter is illustrated in Fig.

10-18. It will be noted that after the slot is cut to depth, as at *a*, the tooth back of *a* does not touch the groove at all. The fact that the angular teeth in this way clear the groove already cut makes it possible to use this kind of cutter for spiral milling. For fluting spiral-milling cutters  $2\frac{1}{2}$ -in. in diameter or more and up to a 25-deg. spiral angle, a double-angle cutter with a 12-deg. angle on one side and either a 40-, 48-, or 53-deg. angle on the other side may be used. To cut a short-lead spiral on a small diameter, for example, a 4.26 lead on a 1-in. end mill, will require a greater angle than 12 deg. on the cutter. It will depend, of course, on the shape of the tooth desired whether a cutter with an included angle of 52, 60, or 65 deg. is used. In any case, the steep side should form the face of the tooth.

**Fig. 10-18.** Hold a double-angle cutter in the groove of a spiral-milling cutter with the cutting edges *a* vertical and touching the sides of the groove; then observe the amount of clearance (space) between the cutting edges *b* and the groove.



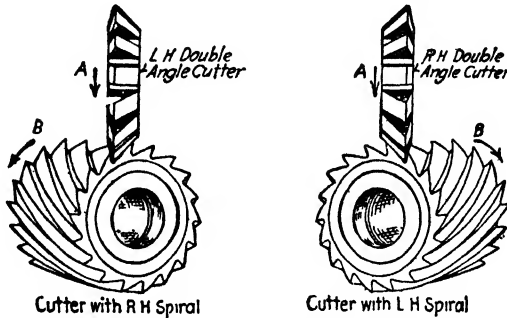
#### Use of Right-hand and Left-hand Double-angle Cutters.

A cutter should be selected, right-hand or left-hand as the case may be, which in operation will free the steep side of the groove; that is, the blank being milled should turn in a direction away from the 12-deg. side of the cutter. This will give a cleaner, smoother surface to the front (or face) of the tooth being milled. The correct setup for milling right-hand and left-hand spiral cutters is shown in Fig. 10-19.

**Setting the Cutter for Spiral Milling.** In the universal milling machine, the *axis* of the cutter and the *pivot center* of the table are in the same vertical plane. It is only in this plane that the cutter cuts its full depth (or its shape) in the work.

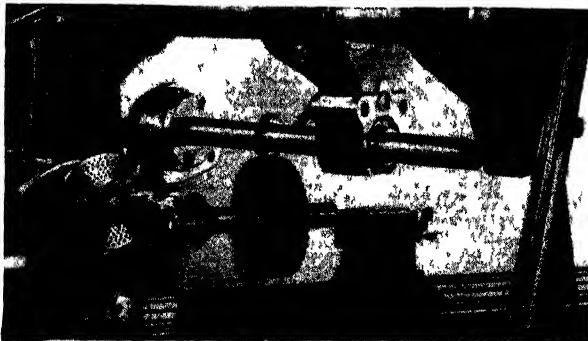
This is one of the most important points to remember in setting up for spiral milling. Suppose the machinist sets up to split a line when the edge of the blank is, say, a quarter of an inch in front of the axis of cutter. Not only is the cut made deeper when the work is fed the

quarter of an inch, but the work *rotates* at the same time it is *fed* and, of course, the line rotates with the work and its relation to the cutter is changed.



**Fig. 10-19.** Illustration of difference in the setting of the table and also in the cutter used when milling right-hand and left-hand spirals. Both views are shown as from the footstock end of the table. Arrow *A* denotes the direction of the cutter, and arrow *B* the direction of the rotation of the blank as the spiral groove is being milled.

When milling spiral flutes that are symmetrical, that is, alike on both sides (for example, the teeth on a spiral gear [Fig. 10-20]), *care must be taken to set the work centrally under the cutter before the table is swiveled.*



**Fig. 10-20.** Milling the teeth in a spiral gear, the teeth being symmetrical (*The Brown & Sharpe Manufacturing Company*)

In setting up for spiral milling when the groove is not symmetrical—for instance, the flute in a milling cutter—it is customary to draw lines on the end of the first blank to be milled which will indicate the

relative positions of the faces of two adjacent teeth. These lines are scribed after the blank is in position between centers, as will be explained later. The end of the blank is then arranged directly over the pivot center of the table, that is, directly under the axis of the cutter; next, the table is swiveled, and then the work may be adjusted on its axis or crosswise or vertically (but *not* longitudinally) under the revolving cutter until the cut made is according to the layout.

The greater the angle of the spiral, the farther the worktable must be moved away from the column, in order to allow the table to be swiveled the required amount. Also the cutter must be arranged on the arbor practically over the pivot center of the table. Since guessing at the position of the cutter on the arbor is likely to cause delay, the following procedure is advisable:

1. Place the work between centers.
2. Swivel the table to the angle of the spiral (Fig. 10-21).
3. Move the table laterally ("cross-feed") until there is  $\frac{1}{2}$  in. or so clearance between the table and the column.
4. Tighten the cutter on the arbor in substantially its proper position over the work. Now it is assured that the cutter is in the right place on the arbor.
5. Bring the table back to straight (zero) and set the end of the work under the axis of the cutter. This is in order to have the cutter in such a position, when the work is being adjusted, that the full depth and exact shape of the groove that will be cut may be noted. It is easier to judge the proper setting when the table is straight.
6. Swivel the table once more to the angle of the spiral, and tighten the clamping screws.
7. Proceed to make the necessary layout and adjustments as explained in the following paragraphs.

**Operation of Setting a Double-angle Cutter.** Many spiral-milling cutters are milled with a 48-12-deg. angle cutter. Assuming that such a cutter is used, the method of procedure for layout, etc., would be as follows: Apply blue vitriol on the end of the blank and with a surface gage, set to height of index centers, scribe a line (1), as shown in *a*, Fig. 10-22. Index for one tooth space and scribe another

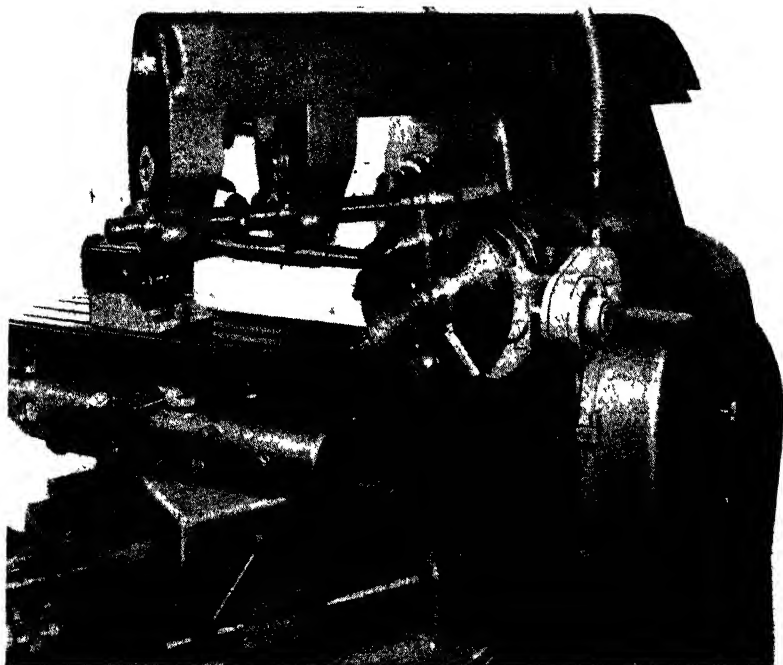


Fig. 10-21. Milling-machine table swiveled to the angle of the flutes of a  $1\frac{1}{2}$ -in.-diameter drill. (*The Cincinnati Milling Machine Company*)

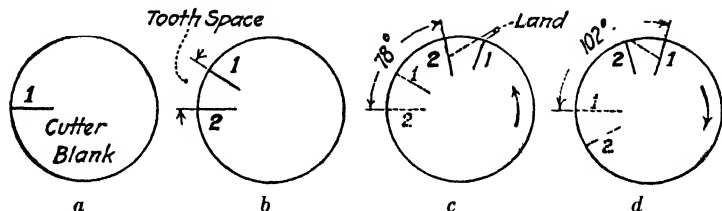


Fig. 10-22. This figure illustrates the method of laying out two adjacent tooth-face lines and indexing these lines to their proper position. (These views are from footstock end with the index head on the left end of the table, as in the Brown & Sharpe machine). Remember, when indexing for a certain number of degrees, that one turn of the index handle moves the work 9 deg.

line (2) as shown in *b*; these two lines represent the faces of two adjacent teeth. When cutting the groove between these two teeth, the cutter and the work must be arranged in such a way that one side of the cutter (the 12-deg. side) will split one radial line, and the other side of the cutter will leave an uncut space, equal to the land required, between the groove and the line representing the face of the next tooth. This is shown in *c*, where the lines (1) and (2) have been rotated to position under the cutter. In the rotating of the blank to bring the lines (1) and (2) into position, it makes a great difference whether a right-hand or a left-hand spiral is being milled. This is illustrated in *c* and *d* (Fig. 10-22). If a right-hand spiral is to be cut, the work will have to be revolved as illustrated in *c*. If the line (2) is moved (indexed) 78 deg. (90 deg. minus 12 deg.), it will bring this line in position for the radial face of the tooth. If the work is moved transversely and vertically until the cut made splits line (2) and approaches close enough to line (1) to leave the amount of land desired on the tooth, then the setting is correct.

If a left-hand spiral is to be cut, the method of procedure after drawing the two lines as illustrated in *d* is as follows:

Rotate the work *back* one tooth space to bring the line (1) on center (as it was originally, see *a*), then rotate it forward again 102 deg. (90 deg. plus 12 deg.) (see *d*, Fig. 10-22). This will bring the line (1) into position for the radial face of the first tooth and line (2) one tooth-space distant so that the amount of the land may be easily judged.

**NOTE:** Above are directions which apply to Brown & Sharpe milling machine and all machines where the index head is on the left end of the worktable. When head is on the right end of the worktable, as in the Cincinnati milling machine, the directions for layout for right-hand and left-hand spiral-milling cutters are reversed.

### A TYPICAL SPIRAL-MILLING JOB

**Job Description.** A right-hand spiral-milling cutter; 2½-in. diameter, 18 teeth, radial face, ⅓₂-in. land, 12-deg. angle of spiral, with 60-deg. (48- to 12-deg.) double-angle cutter.

**Tools Required.** Machine arbor, double-angle cutter 48 to 12 deg., surface gage, scribe, 12-in. combination square, 4-in. inside

calipers, blue vitriol or dykem blue, special shoulder-threaded mandrel, dog, and wrenches.

### OPERATION SHEET

1. Oil milling machine, dividing head, and feed mechanism.
2. Mount work on mandrel; tighten nut securely.
3. Wipe bore of spindle and shank of machine arbor and mount securely. Draw arbor home with draw-in bolt.
4. Adjust index sector for indexing setting

$$\frac{40}{N} = \frac{40}{18} = 2 \text{ turns } \frac{4 \text{ holes}}{18 \text{ circle}} \quad \text{or} \quad 2 \text{ turns } \frac{6 \text{ holes}}{27 \text{ circle}}$$

Withdraw the stop pin at back of plate.

5. Arrange change gears and test by using hand feed to be sure spiral mechanism operates freely.

$$\text{Lead} = \frac{\text{circumference}}{\tan \text{ of spiral angle}} = \frac{2.5 \times 3.14}{\tan \text{ of } 12^\circ \text{ angle}} = \frac{7.85}{0.213} = 36.8 \text{ in.}$$

The nearest lead with available gears on Browne & Sharpe Milling Machine is 37.04; on Cincinnati machine nearest lead is 36. Either will be near enough. Test movement and direction by hand.

6. Swing table to angle of spiral; tighten lightly in this position (temporary); check clearance of table and column; allow  $\frac{1}{2}$  in.
7. Mount cutter blank between index centers.
8. Locate position of cutter and swing table to zero (straight).
9. Adjust milling cutter to the center of the blank.
10. Put bluing solution on the end of the blank where lines are to be scribed.
11. With point of scribe on center draw radial line.
  - a. Fig. 10-22. Index one tooth space and draw line.
  - b. Then index as outlined; according to the arrangement of the head; left or right end of table.
12. Swivel table to required angle and clamp tightly.
13. Cut tooth space to depth, splitting tooth-face line and leave  $\frac{1}{32}$ -in. land. Do this without touching index crank and longitudinal table feed.

14. Either two cuts (roughing and finishing) or one may be taken, depending on condition of machine and cutter. When table is adjusted for the finishing cut set the graduated collars on cross feed and vertical feed at zero.

*NOTE:* The difference between the normal pitch and the circular pitch is, in this case, negligible.

*CAUTIONS:* Make sure that

1. Work is tight on mandrel.
2. Cutter arbor is tight in the spindle.
3. Dog is securely fastened.
4. Dog has plenty of clearance when turning.

*Be sure to lower the table at the end of each cut before returning it for next cut. Raise table before starting new cut.*

### QUESTIONS ON SPIRAL MILLING III

1. What advantage is there in having the card "Table of Approximate Angle for Cutting Spirals"?
2. What is a double-angle cutter? Why is a double-angle cutter better for milling spirals than a cutter with one angle?
3. Make a sketch that will show why a double-angle cutter must be "offset" from center in order to cut a radial tooth.
4. State why it is impossible to give a rule for the amount of offset.
5. Why are double angle-cutters made in both right-hand and left-hand forms? How do you tell one from the other?
6. What do you understand by a vertical plane? When is the end of the work in the same vertical plane as the axis of the cutter?
7. If a cutter is set central over the work before the table is swiveled, is it central after the table is swiveled? Give reason.
8. Is it easier to set the cutter central before or after the table is swiveled?
9. Why is it advisable to arrange the work, swivel the table, and feed the table laterally until it is about  $\frac{1}{2}$  in. from the column before arranging and tightening the cutter on the arbor?
10. When laying out the lines of two adjacent teeth on the end of a spiral-milling-cutter blank, why are the lines rotated either 78 deg. or 102 deg?
11. What is the difference between right-hand and left-hand spiral-milling cutters?
12. Make a sketch similar to Fig. 10-22 to show the method of laying out a right-hand spiral-milling cutter when using a milling machine with the head on the right-hand end of the table.



## CAM MILLING

Cams are being used in modern manufacture to an increasing extent. Cams provide the easiest method of obtaining the intricate and unusual mechanical movements that are often found in the complex machinery of today. Cams can be divided into three classes:

1. Radial, or plate
2. Cylindrical, or barrel
3. Pivoted beam



**Fig. 10-23.** Grinding the contour of a radial cam, using a cam-milling attachment. (*The Cincinnati Milling Machine Company*)

In these three classes, with their many variations and applications, are to be found unusual combinations and types of curves and these create problems in machining.

Whenever a number of cams of similar design have to be machined, economy will require that a cam-cutting attachment or homemade fixture be used (Fig. 10-23). There are other instances where a single cam must be made in order to further the operation of a production machine. An example of this would be the cams used on the auto-

matic screw machine. This type of cam comes under Group 1 and can be machined with the aid of a Universal index head and a vertical milling attachment (Fig. 10-24). The cam shown in this illustration is among the simplest to machine. It is a peripheral cam, more often called a *plate*, or *disk*, cam. These cams can be of many



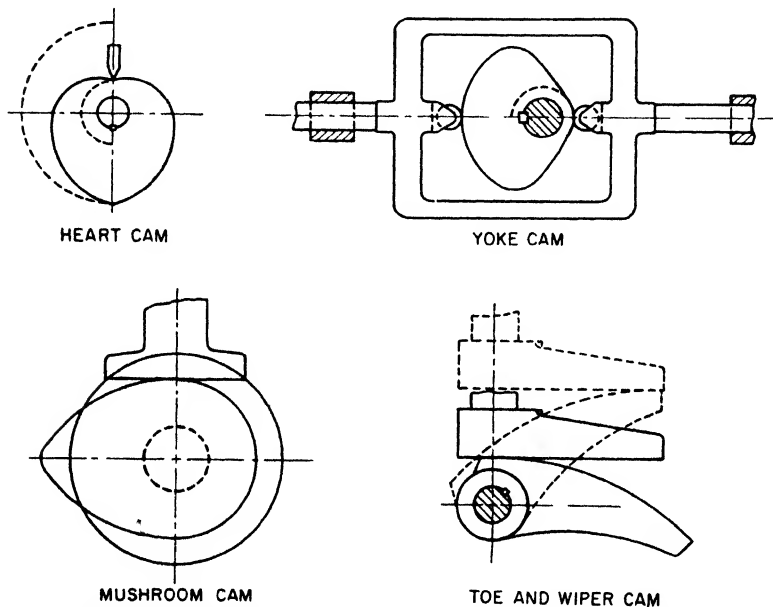
**Fig. 10-24.** Milling a cam, using a universal spiral index head and a vertical milling attachment. (*The Brown & Sharpe Manufacturing Company*)

designs or shapes but in each case the follower rides on the outside, or periphery, of the cam (Fig. 10-25).

The cam is mounted on a shaft that revolves at a uniform speed. One end of the follower has a roller which is held in close contact with the cam, usually by means of a spring. As the cam rotates, the

follower rises and falls to the shape of the cam outline, giving definite but changing motion.

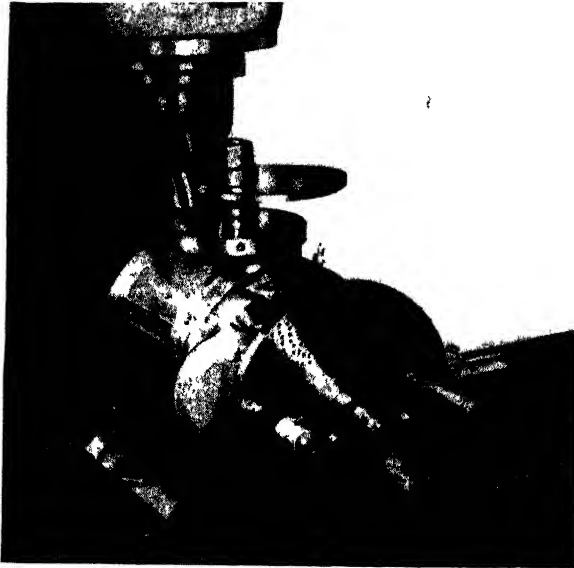
**Machine Set up for Milling a Cam.** There are occasions when a cam can be milled in an index head without any outside gearing (Fig. 10-26). This method often results in unevenly matched surfaces.



**Fig. 10-25.** Four types of cams that can be milled using an index head and a vertical attachment. (*The American Machinist*)

A better method is to gear the index head to the table-feed screw, as in spiral milling (Fig. 10-24). The cam blank is fastened to the index spindle by a special mandrel or in a chuck. An end mill is placed in the vertical milling attachment, which must be aligned with the index head so that the periphery of the cam will be square with its face. When a cam is being milled by this method, the axes of the dividing-head spindle and the spindle of the vertical attachment must always be parallel. The cutting is done by the teeth on the periphery of the end mill.

The principle of this method of milling cams is as follows: If the Universal index head is elevated to 90 deg., as shown in Fig. 10-27, and geared to the table-feed screw with any required lead, as the table advances and the blank turns, the distance between the axes of the index spindle and attachment spindle becomes less. The cut penetrates deeper and the radius of the cam becomes shorter, thus

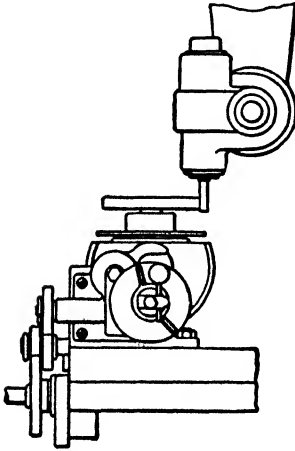


**Fig. 10-26.** Milling a heart-shaped cam with index head and vertical attachment. The cam profile is divided into two identical halves. Indexing 1 deg. for each cam increment, or turning the index crank 6 spaces on the 54-hole circle, the number of settings for each half of the profile is 180. This is duplicated for the other half of the cam. (*The Cincinnati Milling Machine Company*)

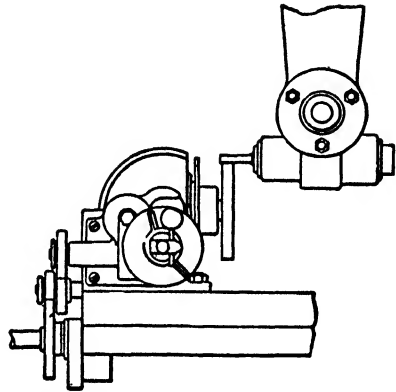
producing a spiral lobe, the lead of which is that for which the machine is geared.

Now, suppose that the same gearing is retained and the spiral head is set at zero (Fig. 10-28). The axes of the index spindle and the attachment will be parallel to one another. As the table advances and the blank is turned, there will be no change in the distance between the two spindles. This would result in the milling of a circle, with no rise or fall in the periphery of the cam blank.

If the headstock is elevated to any angle between zero and 90 deg. (Fig. 10-29), the amount of lead given to the cam will be between that for which the machine is geared and 90 deg. In this way cams with a large range of different leads can be obtained with one set of change gears. The problem of milling the rounded projections, or lobes, of a cam depends upon finding the correct angle for setting the index head to obtain any required lead.



**Fig. 10-27.** Index head set at 90 deg.  
(The Brown & Sharpe Manufacturing Company)



**Fig. 10-28.** Index head set at zero.  
(The Brown & Sharpe Manufacturing Company)

In order to illustrate the method of obtaining the correct angle, a drawing of a cam to be milled and the data required for its milling are here given (Fig. 10-30).

It is first necessary to know the lead of the lobes of the cam—that is, the amount of rise of each lobe if continued the full circumferences of the cam. This can be obtained from the drawing as follows. For cams in which the face is divided into hundredths (Fig. 10-30), multiply 100 by the rise of the lobe in inches and divide by the number of hundredths of circumference occupied by the lobe. For cams that are figured in degrees of circumference, multiply 360 by the rise of the lobe in inches and divide by the number of degrees of circumference occupied by the lobe.

Take Fig. 10-30, for example. We have a cam of one lobe that extends through  $\frac{91}{100}$  of the circumference and has a rise of 0.178 in. Then

$$\frac{100 \times 0.178}{91} = 0.1956 \text{ in. lead of lobe}$$

or 0.196 in., which is near enough for practical purposes.

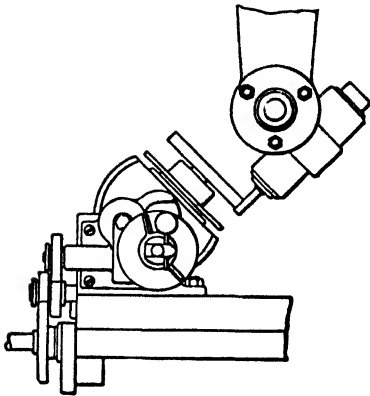


Fig. 10-29. Index head set at an angle between zero and 90 deg. (*The Brown & Sharpe Manufacturing Company*)

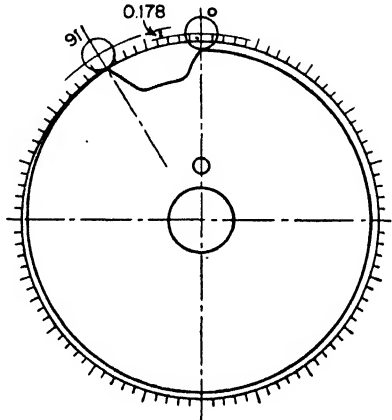


Fig. 10-30. Face of cam divided into 100 parts equally spaced in order to lay out the lobes. (*The Brown & Sharpe Manufacturing Company*)

As a 0.196-in. lead is much less than 0.67 in., which is the shortest lead regularly obtainable on the milling machine, the change gears that will give a lead of 0.67 in. may be used and then the angle of the head can be adjusted so that a lead of 0.196 in. will be obtained on the cam lobe with these change gears.

The rule for this is as follows: Divide the given lead of the cam lobe by a lead obtainable on the machine (see “Table of Leads” in *Brown & Sharpe Treatise on Milling and Milling Machines*) and the result is the sine of the angle at which to set the index head.

Continuing the calculation for the lobe of the cam in Fig. 10-30, we therefore have

$$\frac{0.196 \text{ in.}}{0.67} = 0.29253$$

Therefore, 0.29253 is the sine of the correct angle. Turning to the table of sines and cosines, we find that 0.29253 is very near 0.29265, which is the sine of the angle  $17^{\circ}1'$ . As the index head is not graduated closer than quarter degrees, it will be satisfactory to elevate the head very slightly over 17. Then, with the gearing for a lead of 0.67 in., a cam with a lead of 0.196 in. will be obtained. The minute errors between the actual lead 0.1956 and 0.196 in. and in the sines and angles of this calculation can safely be ignored, as it is not possible in practice to work very much closer than outlined.

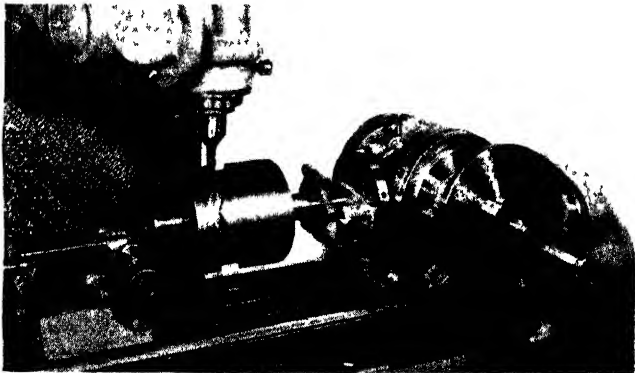


Fig. 10-31. Milling a drum cam with dividing head and vertical attachment. (The Cincinnati Milling Machine Company)

The portion of the periphery of the cam from  $9\frac{1}{100}$  to 0 represents a clearance of the cutting tool prior to the beginning of the throw. It is usually milled to a line or drilled, broken out, and filed. Whenever possible, the job should be set up so that the end mill will cut on the lower side of the blank, as this brings the mill and the table nearer together and makes the job more rigid. It also prevents chips from accumulating and enables the operator to see better any lines that may be laid out on the face of the cam.

When the lead of the machine is over  $2\frac{1}{2}$  in., the automatic feed can be used; but when the lead is less than  $2\frac{1}{2}$  in., the job should be fed by hand with the index crank.

This method of milling cams is suitable only when the lobes of the cam are few in number and within similar height range. Otherwise, it will mean changing the gear ratio.

Other types of cams can be milled with the combination of the index head and the vertical attachment. Figures 10-31 and 10-32 show cams being milled where a combination of power feed and manually controlled table movements are utilized. Figure 10-32 shows a face cam with double lobes, or rises of similar height, being milled. The cam is centered on the index spindle. The cutter is centered with the index spindle and the table is moved in a longitudinal

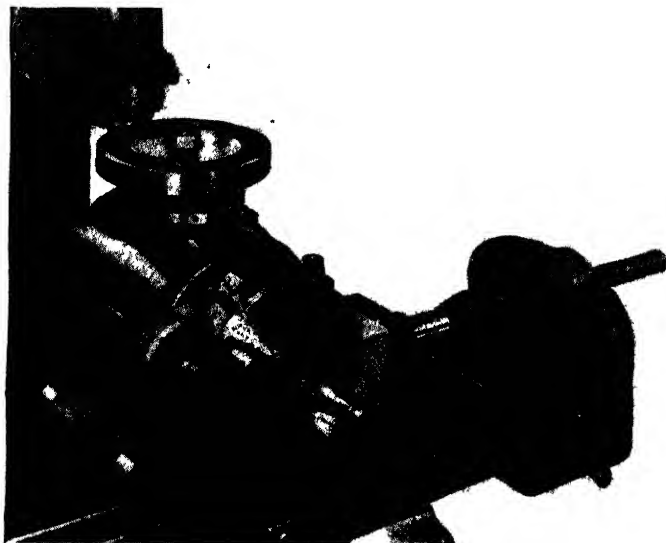


Fig. 10-32. Milling a double-rise face cam (*The Cincinnati Milling Machine Company*)

direction to obtain radius measurement. The cam dwell (the main radius, concentric with the center, where the follower roller remains at rest) is milled by turning the cam blank manually with the index crank while the table remains stationary.

**Rotary Table.** Another milling-machine attachment used to mill cams to accurate size and shape is the rotary table (Fig. 10-33), or, as it is also named, *circular milling attachment*. These attachments are built in two styles: (1) manual feed and (2) power feed, with both manual and power controls. In both styles the circumference of the table is accurately graduated in degrees, while the handwheel



dial is graduated in minutes. A T-handle clamp locks the table in the desired position, and four T slots are provided to bolt the work to the face.

The usual method employed when cams are to be cut on the rotary table is as follows: The cam is laid out to accurate size and shape. In



Fig. 10-33. Milling a template with the rotary table or circular milling attachment (*The Cincinnati Milling Machine Company*)

this procedure, the face is prepared with blue vitriol or dykem blue. The light prick-punch marks used to scribe radii are left in to assist in locating the cam under the center of the vertical attachment. A center is usually placed in the spindle of the vertical attachment for this purpose. Before the cam is placed on the rotary table, its shape—whether plate or groove—is roughed out by a series of drilled holes. The cam is then lined up on the rotary table (center of vertical attachment to center of radius to be cut, the rotary table being rotated for checking). The cam is next moved the exact dis-

tance of the radius. When a grooved cam is milled, a cutter smaller than the width of the groove is used and the sides of the groove are milled with separate cuts. Great care must be taken to remove backlash from the rotary table, and the table must be clamped to prevent any unwanted movement.

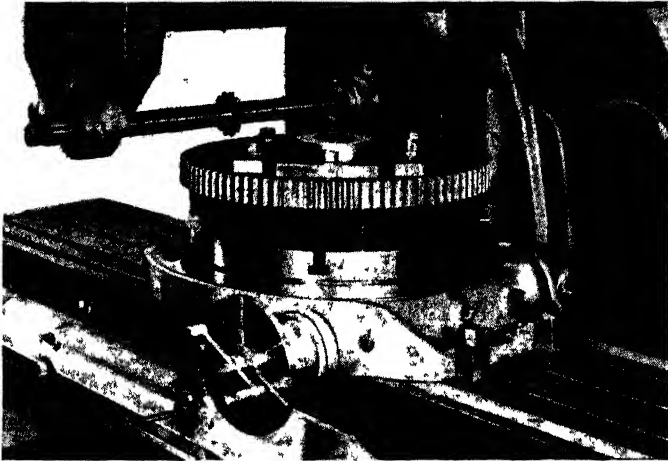


Fig. 10-34. Milling the teeth of a large-diameter spur gear. The circular milling attachment is equipped with a standard index plate. (*The Cincinnati Milling Machine Company*)

An indexing attachment can be fitted to the rotary table so that it can be used to cut gears. The plates used are the standard index plates (see Fig. 10-34).

QUESTIONS ON CAM MILLING

1. Name the three classes of cams.
2. Give the method used to machine many cams of the same shape.
3. Is the plate cam difficult to machine? Why or why not?
4. Explain what is meant by the periphery of a cam.
5. Explain the purpose of the follower.
6. Describe its mechanical features.
7. Is it possible to mill a cam without gearing? Explain.
8. What advantage is there in gearing the head to the table in milling a cam?

9. Make a sketch of the position of the index head, together with the vertical attachment in milling cams.
10. Explain the reason for this related position.
11. What is the *lobe* of a cam?
12. For what purpose does the outline of the cam vary in its distance from the center?
13. State the reason for dividing the face of the cam into a hundred parts.
14. When is it and when is it not safe to use the automatic feed on cam milling?
15. Make a drawing of the rotary table, and explain its use, and label all parts.

## Spur Gears and Bevel Gears

Although the term *gearing* has been rather loosely applied during the past to all elements used in the transmission of motion or power, it is the purpose of this chapter to discuss some of the essential characteristics of toothed wheels which are used for the transmission of angular motion between two shafts so that there will be no slip. In the case of belt drives, there must always be some slip or lost motion and, even though it is a small amount in most cases, this slip might be a disadvantage in the successful operation of certain machines.

By the use of toothed gears it is possible to drive shafts that are parallel, intersecting, or neither parallel nor intersecting, in such a way that a given amount of rotation of one shaft will produce a *definite* motion of the driven shaft. There are many cases, such as interconnected parts of a single machine, or batteries of synchronized machines, or materials-handling devices, where the application of gears provides the best solution of the transmission problem.

The present era of high-speed machinery and mass production has served to bring about a high degree of perfection in the design and manufacture of precision-cut gears from materials of great strength which are capable of transmitting extremely large loads at tooth speeds reaching a mile a minute, and with surprisingly little noise.

Gears are commonly incorporated in the building of machines such as lathes, milling machines, etc., or they are used in the construction of speed-reducing units for driving slow-speed machines by means of high-speed motors and line shafts. They are used in almost any machine that functions as a power transmitter.

This chapter will supply the beginner with sufficient information to enable him to understand gear terms and the rules used in making

spur gears and simple bevel gears. It will give him the application of the rules necessary to turn a gear blank in a lathe or to form the teeth on a milling machine, and will help him to recognize the various types of gears used in industry and to learn their functions—to know what he is doing. This chapter will also deal with the most modern methods of cutting gears for mass-production purposes on machine tools specifically designed to cut gears, such as gear shapers and gear hobbers. Gear-hobbing machines and gear shapers, and bevel-gear generating machines have been in use throughout the world for more than fifty years. These machines are used to cut a few gears when necessary and to cut gears on a mass-production basis, as well. Today, they are known as *universal* machines.

Certain gearing terms are defined, fundamental considerations of gear-tooth shape are introduced, and the rules a machinist should know are included for study and ready reference. In this connection, it is advised that several treatises on gears, including the complete tables of sizes for all gear parts, are published and are easily obtained through technical textbook publishers and gear manufacturers. Definite standards have been set up for gear terms and formulas concerning gears. Some of these have been included in this chapter.

**Definition of a Gear.** The term *gear* may be used in engineering practice for almost any kind of mechanism, but it refers especially to a *toothed wheel*. In other words, a gear is a wheel on which teeth have been formed.

**Gear Types and Their Uses.** The gear types most commonly used in industry are *spur*, *bevel* and *miter*, *internal*, *helical*, *herring-bone*, and *worm* gears. Each will be very briefly described and its ordinary uses mentioned.

**Spur Gear** (Fig. 11-1). This type of gear is a cylinder, wheel, or disk on the surface of which are cut parallel teeth. In the illustration shown, the larger gear is called the *gear* and the smaller, the *pinion*. Usually when two gears are in mesh and one is larger than the other, the names gear and pinion are applied.

Spur gears are most commonly found on industrial machines working under ordinary conditions, at moderate speeds, and with medium pressures exerted upon their teeth. When gears of various sizes, readily removable from both of two shafts, have been made, many different pairs of gears can be provided for the same drive,

giving many different speeds. This arrangement is used principally where different relative speeds are required, as on the standard change-gear lathe. These gears are also known as *change gears*. While it is possible to use other than spur gears as change gears, spur gears are always most convenient and are therefore used for the purpose.

*Bevel and Miter Gears.* Spur gears are used to transmit power from one shaft or element to another in cases where those shafts have their axes parallel. *Bevel gears* are used when it is necessary to transmit power from one shaft to another where the communicating shafts are located at an angle, with their axial lines

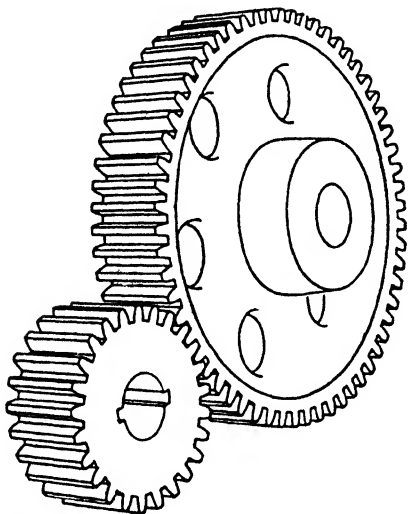


Fig. 11-1. A spur gear and pinion

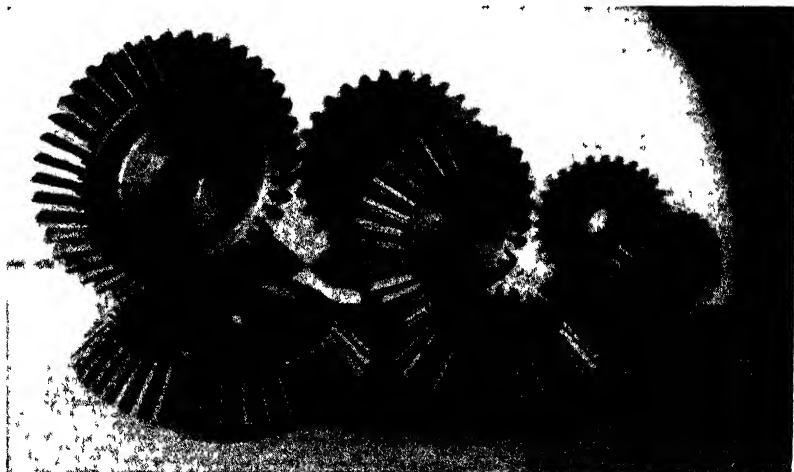


Fig. 11-2. Miter gears. (*Boston Gear Works*)

intersecting. Bevel gears are not restricted to shafts at right angles; there are right-angle bevel gears and angular bevel gears.

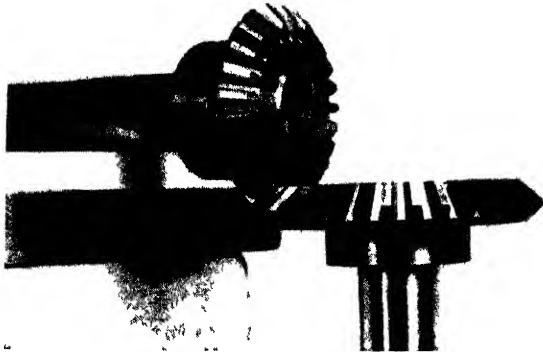


Fig. 11-3. Straight bevel gears.

In cases where the ratio of a pair of bevel gears is 1:1, both gears being the same size and having the same number of teeth, they are known as *miter gears* (Fig. 11-2). These gears permit the driving of one shaft at right angles to the other.

In a bevel gear the teeth are cut on a conical surface, such as would be represented by a truncated cone. Figure 11-3 illustrates bevel gears.

It is possible to make so-called *angular bevel gears* (Fig. 11-4)

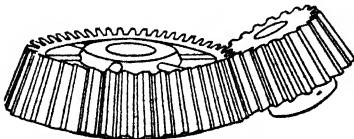


Fig. 11-4. Angular bevel gears.

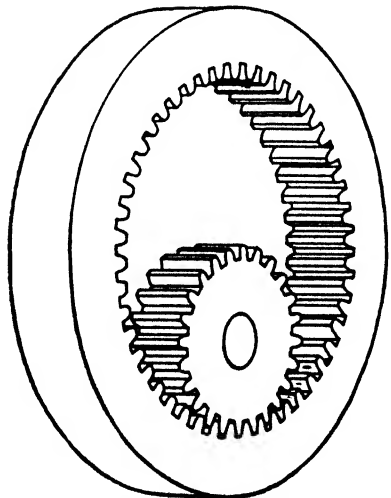


Fig. 11-5. Internal spur gear.

just as readily as bevel gears can be made. Wherever a pair of gears is used to transmit power from one shaft to another, and where the two shafts have their extended axial lines intersecting at some angle

other than 90 deg., the gears are called *angular bevel gears*. Thus, regardless of the particular angle at which a driving shaft is set with the driven, if the axial lines of the two shafts intersect when extended, a pair of angular bevel gears can be readily made which will transmit power from one to the other.

*Internal Gears* (Fig. 11-5). This type of gear has parallel teeth similar to the spur gear but cut on the inside of a cylinder or a ring.

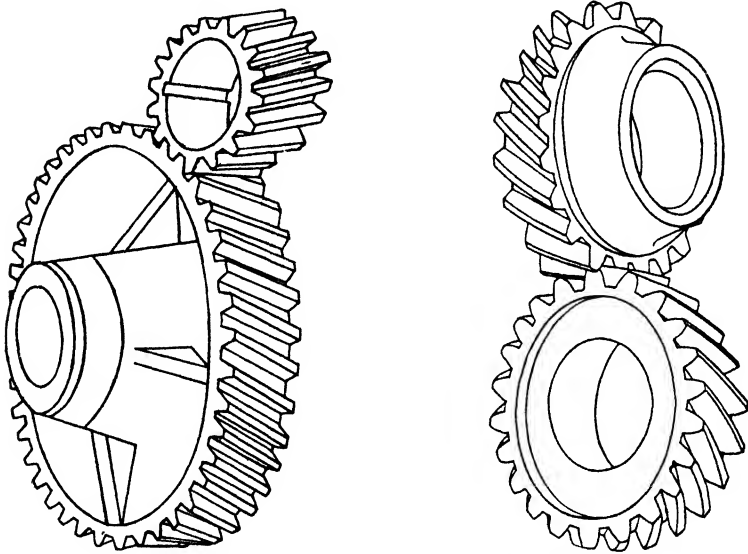


Fig. 11-6. Helical gears. (a) A design of parallel helical gears used to connect parallel shafts. These are sometimes called *spiral* gears. (b) Crossed helical gears, a pair of helical gears used to connect two shafts that cross each other and whose axes are in different planes.

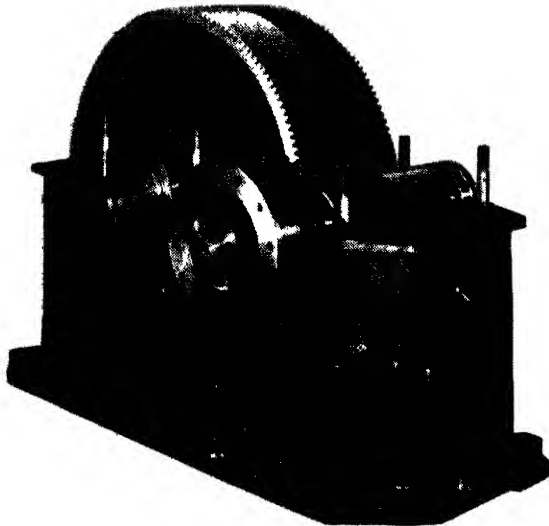
The mating gear may be a spur gear. However, there are internal helical gears and internal bevel gears.

The use of such a combination of gears gives a much more compact mechanism, because the centers on which the two gears revolve are so much closer together than they can be efficiently made with two external spur gears operating as a pair. Thus a large amount of speed reduction may be obtained in a relatively small amount of space. There is also more efficient rolling action between two spur gears when one of them is an internal gear, and there is more contact



of teeth because the tooth lines of both gears curve in the same direction. There is reduced friction and vibration, and there is greater strength with a given material because more teeth are always in mesh. This is one of the reasons why this type of gear is used as the main driving element on certain types of tractors for which great power is needed.

*Helical Gears* (Fig. 11-6). The helical gear resembles the spur gear in that the teeth are cut on a cylindrical body, but the helical gear



**Fig. 11-7.** A pair of continuous-tooth herringbone gears. These gears give the smooth-running advantages of helical gears and also eliminate the end thrust which helical gears set up (*Farrel-Birmingham Company*)

differs from the spur gear in that the teeth are spiraled around the body, instead of being formed parallel to the axis of the gear body. Spiraling the teeth gives a smoother operation. Such gears can be used to connect parallel shafts, and they operate far more smoothly than ordinary spur gears, because action of the teeth is progressive as they roll upon one another.

Helical gears may be used not only to connect parallel shafts but to connect shafts at angles with one another, provided that their axial lines do not intersect.

*Herringbone Gears* (Fig. 11-7). The herringbone gear resembles two helical gears with half right-hand and half left-hand teeth, placed side by side, so that the teeth come together to form a chevron pattern. Herringbone gears are *always* used with parallel shafts.

*Worm Gears* (Fig. 11-8). The machinists know that a worm, which is an integral part of a worm-gear mechanism, is made of a blank which has teeth cut into it in the form of a helix, or screw. It resembles a screw and its teeth are referred to as *threads*. The function of worm gearing is that of speed reduction.

Worms may be made with single, double, triple, etc., threads. Other things being equal, a double-thread worm will revolve the worm gear twice as fast as a single thread, a triple-thread worm will revolve it three times as fast, etc.

The idea of the speed ratio in worm gearing is no different from that in any other gearing; it is merely the ratio of the numbers of teeth. A single-thread worm is similar to a single-tooth gear.

Worm gears that run backward are not uncommon. However, the subject of self-locking or irreversible worm drives is discussed in many handbooks and texts.

*Racks and Pinions* (Fig. 11-9). Many types of racks are used in industry. Some have their teeth cut as spur, while others have helical teeth. The latter are called

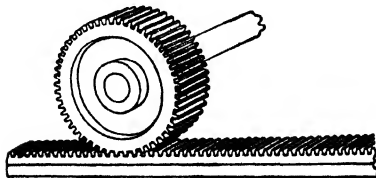


Fig. 11-9. Rack and pinion.

*helical racks*. Many such racks are used for adjusting the position of parts of machine tools. The function of rack and pinion is to transform circular motion to rectilinear motion.

**Methods of Cutting Gears.** Gear teeth are cut in the following ways: on a milling machine using a form cutter, on a gear shaper

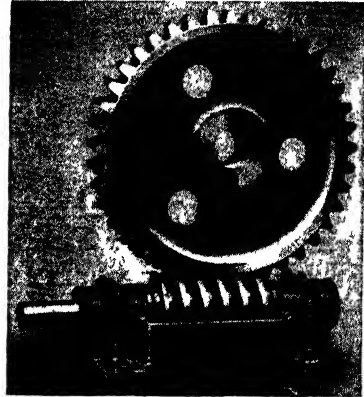


Fig. 11-8. Worm and worm gear  
(The W. A. Jones Foundry & Machine Company)

using special cutters having the shape of the tooth on them, and on a gear hobber using cutters called *hobs*.

Since most vocational and technical high schools of this country do not have gear shapers or gear hobbers as standard equipment, the method of cutting spur gears and simple bevel gears on a milling machine will be explained in detail.

However, for mass production of gears, the milling-machine method of cutting gears is almost obsolete, chiefly because the time taken to cut a gear is much too long, and that makes the procedure very expensive. In many small shops which do not buy their gears from gear manufacturers, the gears are milled on a milling machine. It is logical to believe that where many gears are needed they will either be made on a gear shaper or a hobber or else be bought from a gear company. Later in this chapter, the methods of cutting gears (called *generating gear teeth*) by the gear shaper and the gear hobber are discussed (see pages 385-392).

### SPUR GEARS

**Reasons for Gears.** If two rolls (as in Fig. 11-10a) are in close contact and one is turned, the other will revolve. The circumference of the driven roll will move as many inches as the circumference of the driving roll moves *if there is no slip*, but the drive of part *B* is dependent upon *friction* with part *A*, and only a very light load can be transmitted from *A* to *B*.

If, however, the faces of the two rolls are toothed (as shown in Fig. 11-10b), motion may be transmitted positively from *A'* to *B'* and as great a load may be transmitted as the strength of the teeth will permit. If positive dependence could be placed upon frictional contact, gears would be unnecessary, but as there must invariably be a certain amount of slip when using any kind of drive depending upon friction of rolls, belts, etc., gearing is used to give a positive definite velocity from one shaft or spindle to another.

**Pitch Circle or "Pitch Line."** The pitch circle, or "pitch line," of a gear is that line which represents, in drawings and calculations, an imaginary surface corresponding to the original friction surface. The pitch circles of the two gears *A'* and *B'* are shown in Fig. 11-10b,

and it will be noted that they correspond to the friction surfaces of the two rolls *A* and *B*, respectively, their diameters being equal.

The circles of the two rolls represent real surfaces; in the gears, the pitch lines represent theoretical or imaginary surfaces. However, the pitch circle or, more correctly, the diameter of the pitch circle, the *pitch diameter*, is a very important factor in gearing; the relative velocities of the gears in mesh depend upon their *pitch* diameters, not upon their outside diameters, and further, given the number of teeth, their shape and size depend upon the pitch diameter.

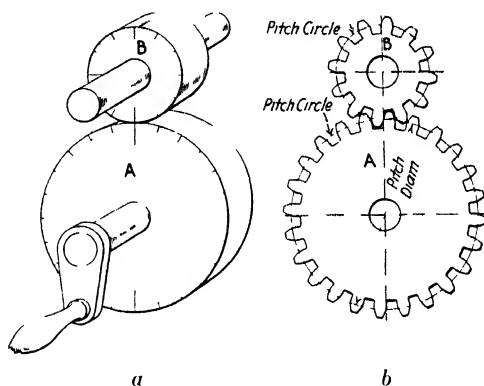


Fig. 11-10. In (a) *B* is half as large as *A* and, with no slip, will make twice as many turns as *A*. In (b) the *pitch circle* of *B'* is half as large as the *pitch circle* of *A'*; therefore, the gear *B'* will go twice as fast as *A'*.

**Tooth Parts.** It will be observed in Fig. 11-10 that when one is sizing the outside diameter of gear blanks, they must be made large enough to provide for the part of the tooth above the pitch circle; furthermore, the tooth *spaces* must be cut deep enough below the pitch circle to allow the teeth of the mating gears to engage properly. This radial distance between the pitch circle and the top of the tooth is called the *addendum* (Fig. 11-11), and between the pitch circle and the bottom of the tooth, the *dedendum*. In order that the top of the tooth of the gear shall not rub on the bottom of the space of the mating gear, the spaces are cut deep enough to allow for *clearance*. That is, the dedendum is made equal to the addendum plus the clearance.

The *whole depth* of a gear tooth is the radial distance between the outside circle and the root circle and is equal to twice the addendum plus the clearance. The *working depth* is equal to twice the addendum.

The *thickness* of the tooth (circular thickness) is measured on the pitch circle (see page 357).

The *face* of a tooth is the surface between the pitch-line element and the top of the tooth, and the *flank* is the surface between the pitch-line element and the bottom, including the fillet.

In order that the gear teeth shall transmit motion smoothly, they must be properly shaped. How the addendum, working depth, clearance, etc., are calculated will presently be explained; other definitions and explanations are in order first.

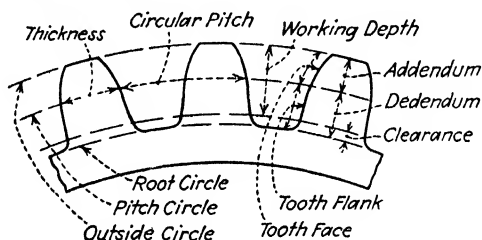


Fig. 11-11. Parts of a spur-gear tooth.

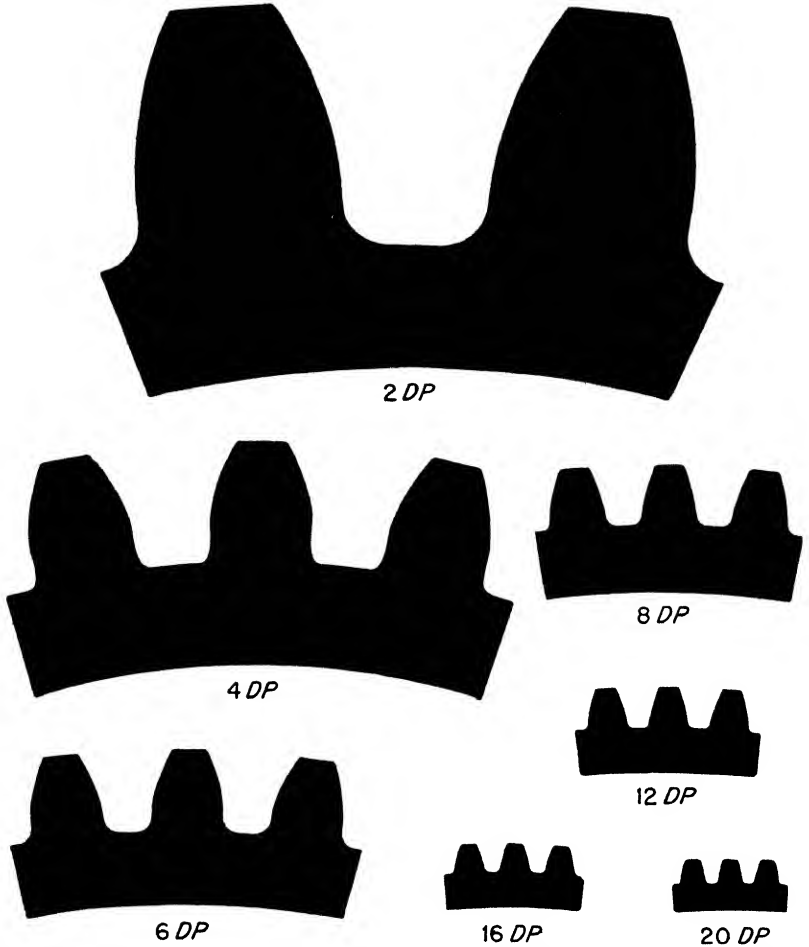
**Circular Pitch.** The distance between similar sides of adjacent teeth measured on the pitch line is called the *circular pitch*. (In racks it is called the *linear pitch*.) There are as many circular pitches in a gear as there are teeth in that gear.

The term *pitch* is used in machine work to denote a size. Before the days of indexing devices, formed cutters, and gear-cutting machines, most gears were cast gears, the patterns were laid out in the pattern shop, and then the gears were cast and filed more or less to shape. Circular pitch was then used to designate the size of the gear tooth, and easily measured pitches such as  $\frac{1}{4}$  in.,  $\frac{1}{2}$  in.,  $\frac{3}{4}$  in., etc., were used. The patternmaker used the circular pitch (or more correctly, he used the chord of the circular pitch or "chordal pitch") to space the teeth in the pattern gears, and the calculations for diameter, center distance, etc., were based on circular pitch. Today, however, the circular pitch is used only in calculations for gears of 3-in. circular pitch and larger, because a simpler and better system for the smaller pitches has been devised.

**Diametral-pitch Idea.** The circumference of a circle is 3.1416 times the diameter; consequently if either is a simple figure or fraction, the other is a decimal, more or less awkward to handle in calculations. There is no question of the value of a gear system in which the *pitch diameters* rather than the pitch circumferences are simple dimensions. Indexing devices have been developed for accurately spacing the teeth and consequently no layout for circular pitch or even chordal pitch is necessary, and further, since the formed tooth cutter will form the teeth within commercial limits of accuracy, no layout for the tooth shape is necessary in the shop. Therefore, there being no particular advantage in having the circular pitch an even number or an easily used fraction, and every advantage in having a system which simplifies calculations and measurements, the *diametrical-pitch system* was devised. This system bases the gear calculations and measurements on the pitch diameter rather than on the pitch circumference, and the pitch diameters, center distances between gears, working depth of teeth, etc., are easily handled figures and fractions.

**Diametral Pitch.** In the diametral-pitch system the pitch diameter is made a convenient dimension, 2 in., 3 in.,  $3\frac{1}{2}$  in., etc. A designer may put any number of teeth desired on a gear of a given diameter; for example, on one gear of 2-in. pitch diameter he may put 20 teeth and on another gear, of the same pitch diameter, he may put 40 teeth. On the 20-tooth gear he will have a larger, stronger tooth; on the other the teeth will be half as large but the gear will run more quietly. These gears, of course, will not mesh with each other but either of them will mesh with a gear having teeth of corresponding size. Note that on one gear (2-in. pitch diameter, 20 teeth) there are 10 teeth to each inch of pitch diameter, and on the other gear (2-in. pitch diameter, 40 teeth) there are 20 teeth to each inch of pitch diameter. In this system the one is a 10-*DP* gear and the other is a 20-*DP* gear. See Fig. 11-12 for the relative sizes of various pitch teeth.

The diametral pitch of a gear is the *number* which expresses the number of teeth in that gear for each inch of its pitch diameter. It expresses also the *size* of the gear tooth, as will be explained presently. Diametral pitch is represented by the letters *DP*; circular pitch by *CP*. In gearing, whenever the word *pitch* is used alone, *diametral*



**Fig. 11-12.** Relative sizes of gear teeth of seven different pitches. (*The Brown & Sharpe Manufacturing Company*)

pitch is meant. Perhaps a better idea of diametral pitch may be obtained more quickly if the student understands the module.

**Module** (in English Measure). The module (meaning measure) is the same proportional part of the pitch diameter as the circular pitch is of the pitch circumference. That is, if the pitch diameter of a

gear is divided into as many equal parts as there are circular pitches (teeth) in the gear, each part will be a definite distance, which is called the *module*. In a gear, for example, 3-in. pitch diameter, 30 teeth, the module is  $\frac{1}{10}$  in., and in a gear 2-in. pitch diameter, 24 teeth, the module is  $\frac{1}{12}$  in. Note in each case, that the module is a fractional part of an inch and equals one divided by the pitch  $\frac{1}{DP}$ . In other words, module is the reciprocal of the diametral pitch.

The term *module* is seldom used in this country; the expression  $\frac{1}{DP}$  is used instead.<sup>1</sup>

**NOTE:** As a possible means of making clearer the meaning and value of diametral pitch and module this note is added:

The circular pitch is 3.1416 times as large as the module, or the module is  $\frac{1}{3.1416}$  as large as the circular pitch. Therefore it is impossible to have both the circular pitch and the module an even number. It is better to have the pitch diameter of gears some common dimension such as 3 in.,  $3\frac{1}{2}$  in., 4 in., 6 in., 8 in., etc., and to let the circular pitch be what it may; consequently it is common practice when designing cut gears, to make the module some nominal part of an inch such as  $\frac{1}{12}$  in.,  $\frac{1}{8}$  in.,  $\frac{1}{4}$  in., etc. Now these common fractions (modules) could be used in gear calculations, but as it is easier to use whole numbers than it is to use fractions, the reciprocal of the fraction is used and it is called the *diametral pitch*. For instance, it is easier to say "12-DP gear" than it is to say " $\frac{1}{12}$ -inch module gear" and more convenient to express and perform multiplication by 12 than division by  $\frac{1}{12}$ .

**Gearing Nomenclature.** The understanding of gears, even spur gears and the simplest kinds of bevel gears as discussed in this chapter, means, of course, a knowledge of the terms used. Some of these gear terms have already been explained. For some time past, committees have been engaged in developing standards for the terms, abbreviations, and symbols for various gear elements. Many of the old terms have been approved, and some changes have been made

<sup>1</sup> In metric gears *module* is used and the term *diametral pitch* is not used (see page 354).

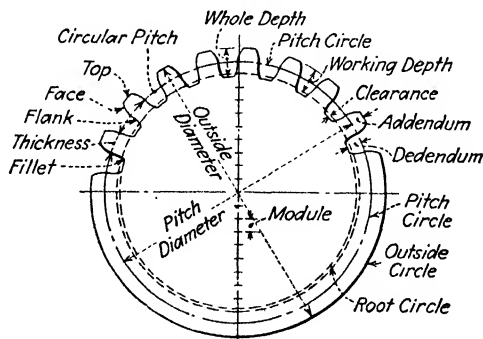


and approved. The terms and definitions used in this book are from "Recommended Practice of the American Gear Manufacturers' Association for Gearing Nomenclature."

It takes years to establish a "standard," and during this time manufacturers make and sell hundreds and thousands of their own designs of, say, tapers, machine keys, and gears. For several reasons—some of them, no doubt, sound reasons—these companies adhere to their sizes, etc., even after a standard has been well established. This is a fault if the accepted standard is as good or better than their design, but it is nevertheless a condition the machinist has to meet. He can usually meet it if he has an understanding of the principles involved, plus resourcefulness.

The machinist should know the meaning of the commonly used gear terms; he should be able to make the necessary calculations for spur gears, and the simpler types of bevel gears. It is not necessary to learn all the rules, but it is well worth while to know where to find them when needed, and how to use them.

#### **DEFINITIONS AND RULES: SPUR-GEAR ELEMENTS AND TOOTH PARTS** (Fig. 11-13)



**Fig. 11-13.** Spur-gear elements and tooth parts.

**Addendum.** The radial or perpendicular distance between the pitch circle and the top of the tooth; equals  $1 \text{ in.}$  divided by the diametral pitch. (This may be multiplied by a factor for special addenda.)

**Base Diameter.** The diameter of the circle from which the involute is generated; equals pitch diameter times the cosine of the pressure angle.

*Bore Diameter.* The diameter of the hole in the gear.

*Bottom Land.* The surface between the flanks of adjacent teeth.

*Center Distance.* The shortest distance between the axes of mating gears.

*Chordal Addendum.* The radial distance from the circular thickness chord to the top of the tooth. To obtain: Subtract from 1 the cosine of the angle obtained by dividing 90 deg. by the number of teeth; multiply the result by the pitch diameter and then divide by 2; add this amount to the addendum. (The chordal addendum and chordal thickness are used when a high degree of accuracy is required in measuring gear teeth.)

*Chordal Thickness.* The length of the chord subtended by the circular thickness. To obtain: Multiply the pitch diameter by the sine of the angle obtained by dividing 90 deg. by the number of teeth.

*Circular Pitch.* The distance on the circumference of the pitch circle between corresponding points of adjacent teeth; equals 3.1416 divided by the diametral pitch.

*Circular Thickness.* The thickness of the tooth on the pitch circle; equals 1.57 divided by the diametral pitch. See also *Chordal Addendum* and *Chordal Thickness*.

*Clearance.* The radial distance between the top of a tooth and the bottom of the mating tooth space; equals (usually) 0.157 divided by the diametral pitch.

*Delendum.* The radial or perpendicular distance between the pitch circle and the bottom of the tooth space; equals (usually) 1.157 divided by the diametral pitch.

*Diametral Pitch.* The ratio of the number of teeth to the number of inches in the pitch diameter. It indicates the number of teeth in the gear for each inch of pitch diameter; equals number of teeth divided by the pitch diameter.

*Face Width* (face of gear). The width of the pitch surface.

*Face of Tooth.* The surface between the pitch-line element and the top of the tooth.

*Flank of Tooth.* The surface between the pitch-line element and the bottom. It includes the *fillet*, which is the curved surface that adjoins the bottom land of the tooth space.

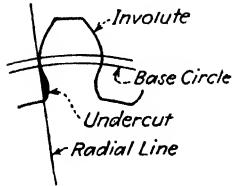
*Gear Ratio.* The ratio of the numbers of teeth in mating members.

*Interference.* Contact between meeting teeth at some point other than along the line of action. In the gears with a small number of teeth special provision is made to avoid interference, even to the extreme of an undercut (see *Tooth Surface*, Fig. 11-14).

*Involute.* See section on Shape of Gear Tooth and Fig. 11-15.

*Line (Path) of Action.* That portion of the common tangent to the base circles along which contact between mating involutes occurs (see Fig. 11-17).

*Module.* See section on the Module.



**Fig. 11-14.** Shows a gear-tooth undercut.

*Outside Diameter.* The diameter of the circle that contains the tops of the teeth.

*Pitch Circle.* The circle through the pitch point having its center at the axis of the gear.

*Pitch Circumference.* Circumference of the pitch circle.

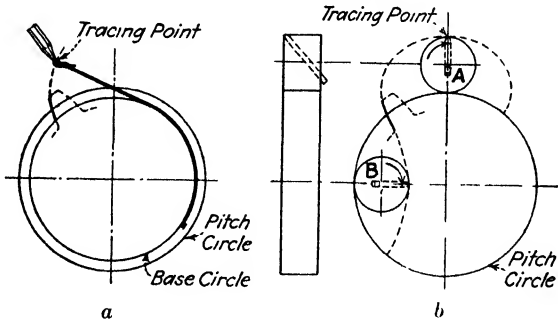
*Pitch Cylinder.* The cylinder corresponding to the pitch circle.

*Pitch Diameter.* The diameter of the pitch circle; equals number of teeth divided by the diametral pitch.

*Pitch Line.* The line formed by the intersection of the pitch surface and the tooth surface.

*Pitch Point.* The intersection, between the axes, of the line of centers and the common tangent to the base circles.

*Pitch Surface.* The surface of the pitch cylinder.



**Fig. 11-15.** Generating (a) an involute curve, (b) cycloidal curves (outside of circle, *epicycloid*; inside of circle, *hypocycloid*). These curves are interesting as showing the theory of gear-tooth shape. A high degree of accuracy is employed in making the cutters, and attention must be given to having them sharpened properly.

*Pressure Angle.* In involute gears, the angle between the line of action and a perpendicular to the common center line of mating gears; in any type of gear it is equal to a tangent to the tooth profile and a line perpendicular to the pitch surface;  $14\frac{1}{2}$  deg. and 20 deg. are standard pressure angles (see Fig. 11-17).

*Root Circle.* The circle containing the bottoms of the tooth spaces.

*Root Diameter.* The diameter of the root circle; equals pitch diameter minus two dedenda.

*Thickness.* See *Chordal Thickness* and *Circular Thickness*.

*Tooth Face, Fillet, and Flank.* See *Face of Tooth* and *Flank of Tooth*.

*Tooth Surface.* Includes both face and flank.

*Undercut.* That portion of the tooth surface, adjacent to the involute, lying inside a radial line passing through an imaginary intersection of the involute and the base circle (Fig. 11-14). Such a tooth outline is found in gears with few teeth.

*Whole Depth.* The radial distance between the outside circle and the root circle; equals addendum plus dedendum.

*Working Depth.* The greatest depth to which a tooth of one gear extends into the tooth space of a mating gear; equals addendum of pinion plus addendum of gear, or (usually) twice the addendum of either.

#### RULES AND FORMULAS FOR DIMENSIONS OF SPUR GEARS

These rules and formulas are for  $14\frac{1}{2}$ -deg. composite system;  $14\frac{1}{2}$ -deg. involute (generated) system, and 20-deg. full-depth stub involute system. (For information concerning stub-tooth gears see page 366).

**Shape of Gear Tooth.** To obtain a smooth, quiet, uniform rolling action (conjugate gear-tooth action) of mating gears of the same pitch regardless of size, the teeth must be properly shaped. The experience of many years has gradually limited the shape of gear teeth to the involute curve, or a composite of involute and cycloidal curves (see Fig. 11-15).

These curves are not laid out by the machinist or even by the average toolmaker; they are, however, a very important feature of gear-tooth design and as such should be of interest to the machinist (see Fig. 11-16). It has been learned that gears formed according to these curves can be made economically, and that, when running together, they have a *rolling action*, one against the other, at a prescribed *pressure angle*, in interchangeable gears of whatever size. Also, there is an absence of interference—the tendency of the top of one tooth to dig into a mating tooth—except in gears with few teeth, where it is easily corrected.

The gears cut with rotary cutters, as in the general-purpose machine shop, are of the *composite system*, which is *based upon the*

To find	Having	Rule	Formula
1. Diametral pitch	Circular pitch	Divide 3.1416 by the circular pitch	$DP = \frac{3.1416}{CP}$
2. Diametral pitch	Number of teeth and pitch diameter	Divide number of teeth by pitch diameter	$DP = \frac{N}{PD}$
3. Diametral pitch	Number of teeth and outside diameter	Add 2 to the number of teeth and divide by the outside diameter	$DP = \frac{N + 2}{OD}$
4. Circular pitch	Diametral pitch	Divide 3.1416 by the diametral pitch	$CP = \frac{3.1416}{DP}$
5. Circular pitch	Pitch diameter and number of teeth	Divide the pitch diameter of the product of 0.3183 and the number of teeth	$CP = \frac{PD}{0.3183N}$
6. Number of teeth	Pitch diameter and diametral pitch	Multiply the pitch diameter by the diametral pitch	$N = PD \times DP$
7. Number of teeth	Outside diameter and diametral pitch	Multiply the outside diameter by the diametral pitch and subtract 2	$N = OD \times P - 2$
8. Pitch diameter	Number of teeth and diametral pitch	Divide the number of teeth by the diametral pitch	$PD = \frac{N}{DP}$
9. Pitch diameter	Outside diameter and addendum	Subtract two times the addendum from the outside diameter	$PD = OD - 2s$
10. Outside diameter	Number of teeth and diametral pitch	Add 2 to the number of teeth and divide by the diametral pitch	$OD = \frac{N + 2}{DP}$

To find	Having	Rule	Formula
11. Outside diameter	Number of teeth and pitch diameter	Add 2 to the number of teeth and divide this sum by the quotient of number of teeth divided by the pitch diameter	$OD = \frac{N + 2}{\frac{N}{PD}}$
12. Outside diameter	Pitch diameter and diametral pitch	Add to the pitch diameter the quotient of 2 divided by the diametral pitch	$OD = PD + \frac{2}{DP}$
13. Thickness of tooth	Diametral pitch	Divide 1.57 by the diametral pitch	$CTh = \frac{1.57}{DP}$
14. Clearance	Diametral pitch	Divide 0.157 by the diametral pitch	$C = \frac{0.157}{DP}$
15. Whole depth of tooth or tooth space	Diametral pitch	Divide 2.157 by the diametral pitch	$WD = \frac{2.157}{DP}$
16. Center distance	Pitch diameters	Divide sum of the pitch diameter of the pair of gears by 2	$CD_t = \frac{PD + pd}{2}$
17. Center distance	Numbers of teeth and diametral pitch	Add together the numbers of teeth and divide one-half the sum by the diametral pitch	$CD_t = \frac{1}{2} \frac{(N + n)}{DP}$

*involute curve*, and have that curve in the proximity of the pitch line, but are modified by having the cycloidal curves for the remainder of the surface of the tooth (see Fig. 11-16). The modification is for the purpose of eliminating the interference on gears with the smaller numbers of teeth. The cutters are accurately formed to give the composite involute-cycloid curves on the tooth profile.

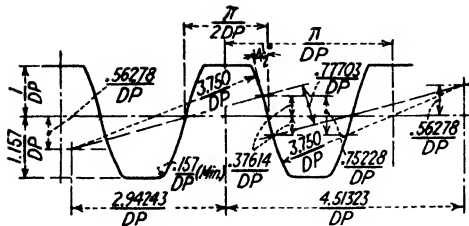


Fig. 11-16. Approximation of basic rack for  $14\frac{1}{2}$  deg. composite system. It is, in fact, the basic rack for the "standard involute gear" with a base circle of  $0.968 PD$ , slightly modified by the cycloidal curves at the lower and upper portions of the teeth. Without this modification, the gears with few teeth would be seriously undercut.

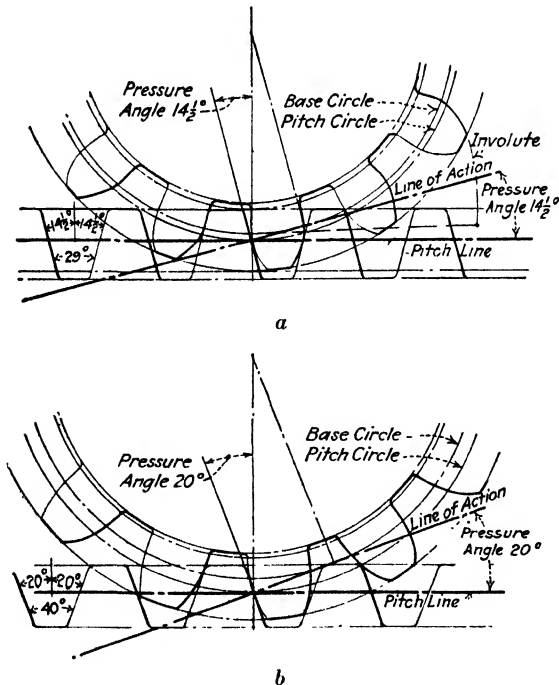


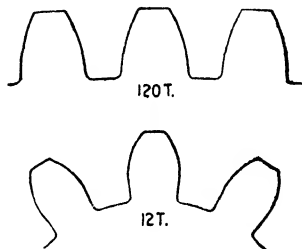
Fig. 11-17. Gear and rack; (a)  $14\frac{1}{2}$ -deg. pressure angle; (b) 2-deg. pressure angle. Note that the tooth in (b) is proportionally shorter; this is a "stub tooth."

**The Base Circle and Pressure Angle.** The base circle<sup>2</sup> of the gear (corresponding to the cylinder from which the involute curve is generated) is somewhat smaller than the pitch circle to give a profile of the tooth which will have the desired pressure angle.

Referring to Fig. 11-17, it will be observed that the pressure of one gear tooth against another is at right angles to the profile of the tooth along the line (or path) of action. This line of action is not tangent to the pitch circle but is tangent to the base circle and therefore forms an angle with the pitch line. (In mating gears the pitch line as shown in the figure would be a common tangent to the pitch circles of both gears.)

Angles of  $14\frac{1}{2}$  deg. and 20 deg. are standard pressure angles. Formerly the angle of  $14\frac{1}{2}$  deg. was the only standard, but the 20-deg. angle has found favor for the fast-running gears with fewer teeth, because it reduces the need of undercutting and hence gives

**Fig. 11-18.** This figure shows portions of two gears of same pitch, 120 teeth and 12 teeth. Note the difference in the shapes of the teeth and also in the grooves between the teeth.



a longer line of tooth action and therefore a smoother and more quiet action.

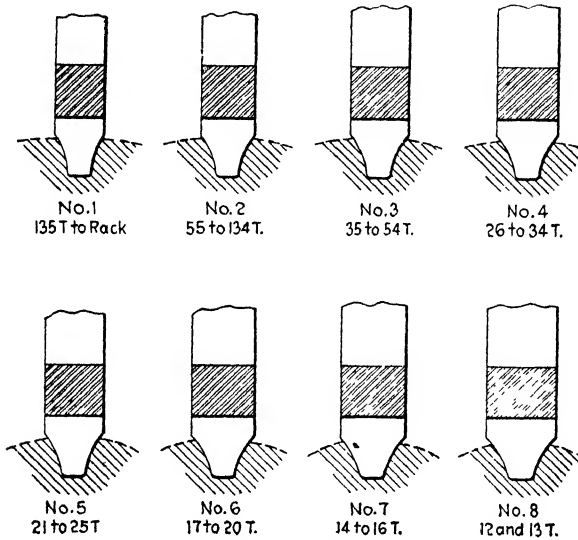
In any gear the shape of the tooth is more or less curved; the smaller the gear of a given pitch, the more it curves. This is illustrated in Fig. 11-18. Theoretically, to obtain a smooth rolling action between the pairs of gear teeth in mesh would require a different tooth curve, a different shape of tooth space, for each size of gear of

<sup>2</sup> With  $14\frac{1}{2}$ -deg. pressure angle the diameter of base circle is 0.968 of pitch diameter; with 20-deg. pressure angle the diameter of base circle is 0.940 of pitch diameter. (Diameter of base circle equals pitch diameter of gear multiplied by cosine of pressure angle.)

The terms *involute*, *base circle*, *pressure angle* relate more particularly to gear design than to the operation of cutting gears. Those interested in obtaining further information are referred to *Treatise on Gearing*, Brown & Sharpe Manufacturing Company, Providence, R.I., 1951.



the same pitch, this difference being more pronounced in the smaller gears. However, it has been found by experience that a set of eight cutters for each pitch will serve to cut all sizes of gears, from 12 teeth to a rack, and will give commercially satisfactory results. Figure



**Fig. 11-19.** The set of eight cutters for 10 DP.

11-19, which represents a set of cutters for 10 pitch, illustrates how the shapes of the tooth spaces vary.

**Gear Cutters.** Cutter manufacturers have adopted the following system (originated by Brown & Sharpe Manufacturing Company) of numbering the cutters for involute gear teeth:

**Involute Gear Cutters (Brown & Sharpe System)**

- No. 1 will cut gears from 135 teeth to a rack
- No. 2 will cut gears from 55 teeth to 134 teeth
- No. 3 will cut gears from 35 teeth to 54 teeth
- No. 4 will cut gears from 26 teeth to 34 teeth
- No. 5 will cut gears from 21 teeth to 25 teeth
- No. 6 will cut gears from 17 teeth to 20 teeth
- No. 7 will cut gears from 14 teeth to 16 teeth
- No. 8 will cut gears from 12 teeth to 13 teeth

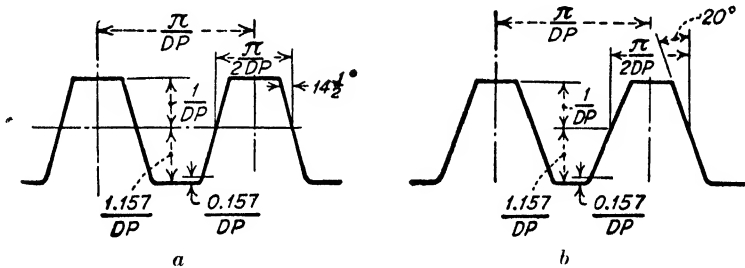
(Cutters made accurate as for the smallest gear in its range)

If a cutter is wanted for a gear, 40 teeth, 8 pitch, then the cutter required will be No. 3, 8 pitch, inasmuch as a No. 3 cutter will cut all gears containing from 35 to 54 teeth, inclusive.

For those who require a finer division of the number of teeth to be cut with each cutter the manufacturers will furnish cutters in half numbers as follows:

Number of cutter	Range	Number of cutter	Range
1½	80 to 134 teeth	5½	19 to 20 teeth
2½	42 to 54 teeth	6½	15 to 16 teeth
3½	30 to 34 teeth	7½	13 teeth
4½	23 to 25 teeth		

**Full-depth 14½-deg. and 20-deg. Involute Gears.** Most gears are made in quantities in gear-generating machines and are



**Fig. 11-20.** (a) Basic rack of 14½-deg. generated gear-tooth system; (b) basic rack of 20-deg. full-depth, gear-tooth system.

based on the involute alone because they can be more easily and accurately generated. They are made in 14½-deg. and 20-deg. full-depth systems. These gears are often made especially for the purpose intended and may be somewhat modified from the basic standards, the racks of which are illustrated in Fig. 11-20. Certain modifications are listed in tables<sup>3</sup> and no doubt some of them will eventually become standard. These changes do not apply to composite-system gears cut by rotating cutters in a milling machine.

<sup>3</sup> For special information, tables of sizes, etc., consult F. H. Colvin and F. A. Stanley, *American Machinists' Handbook*, 8th ed., McGraw-Hill Book Company, Inc., New York, 1945.

**The 20-deg. Stub Tooth.** When extra strength of the gear is needed, or when both mating gears have a smaller number of teeth

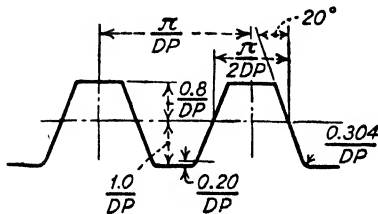


Fig. 11-21. Basic rack of 20-deg. stub-tooth gear system.

and fast speed with smooth quiet action is essential—as, for example, in automobile transmission gears—the stub tooth with 20-deg. pressure angle is used. The stub tooth adopted by the American Gear Manufacturer's Association is illustrated in Fig. 11-21, with the sizes of tooth parts. The rules

and formulas for finding the gear dimensions are the same as those on pages 360 and 361, except for the following substitutions:

$$(3) DP = \frac{N + 1.6}{OD}; \quad (7) N = OD \times DP - 1.6; \quad (10) OD = \frac{N - 1.6}{DP}$$

$$(11) OD = \frac{(N + 1.6) PD}{N}; \quad (12) OD = DP + \frac{1.6}{DP}; \quad (14) C = \frac{.2}{DP}; \quad (15) WD = \frac{2.2}{DP}$$

The Fellows Gear Shaper Company's system is based on two standard-involute diametral pitches, as for example  $\frac{4}{5}$ . The numerator indicates the diametral pitch to be used in calculating the thickness and the diametral pitch; the denominator indicates the diametral pitch to be used in calculating the addendum and the working depth (equals two addenda); the clearance equals  $\frac{1}{8}$  of the working depth. The calculations for  $\frac{4}{5}$  stub gear, for example, are as follows: Thickness is  $\frac{1.57}{4}$  same as for  $4DP$ ; addendum is  $\frac{1}{5}$ , equals 0.200, same as for  $5DP$ ; working depth equals two addenda, equals 0.400, same as for  $5DP$ ; clearance is  $\frac{1}{8}$  of the working depth, equals 0.050; depth below pitch line equals addendum plus clearance, equals 0.250; whole depth equals addendum plus depth below pitch line, equals 0.450.

**Values Not Standard.** The composite gear tooth with a  $14\frac{1}{2}$ -deg. pressure angle (Fig. 11-16) made according to the diametral-pitch system, as described in the preceding pages, is regarded in this country as standard. The metric gears, proportioned exactly the same, the difference in sizes being due to the difference in the units of measurement (English and metric) are regarded as standard in the countries using the metric system.

There is no doubt about the value of having standards and holding to standards as far as practicable; on the other hand, perhaps no standard is the best for all conditions. For example, special tapers, special screws, and special gears are often better adapted for a given purpose than standard sizes would be. Also new conditions, improved facilities, wider experience, and more thorough investigation may result in new standards.

The automobile is responsible for a new series of thread pitches now generally accepted as the National Fine (*NF*). The automobile is responsible also for the increased use of the 20-deg. pressure-angle gear.

Special gears require special cutters. These cutters may be obtained from cutter manufacturers or, possibly, may be already available, but in order to duplicate a special gear or to make a gear which will mesh with a special gear requires on the part of the operator or the foreman a general knowledge of gear standards and, in addition, *certain information concerning that particular gear*. Whether it is 14½-deg. or 20-deg., full-depth or stub gear, with or without modifications such as increased addendum on the pinion and decreased outside diameter on the mating gear, and sometimes whether or not it is a metric gear must be known.

### QUESTIONS ON SPUR GEARS

1. Watch two engaging gears run. Can you imagine the "original friction surfaces" or the two "pitch cylinders"?
2. What part of a tooth is the addendum? Dedendum? Working depth? Is the working depth equal to the whole depth? What is it equal to?
3. What is the circular pitch of a gear?
4. What is the difference between a ¼ in. module gear and a "4-pitch gear"?
5. The whole depth of a gear tooth is 2.157*DP*. Explain where you get the 2.157.
6. It is usually a simple matter to get from a broken gear or a worn gear sufficient information for calculating the sizes for a new gear. The first thing to get is the pitch. In the first calculation the answer may be a fraction, but it will be so near a whole number that no doubt this whole number may be taken as the pitch. The outside diameter of an old gear that is to be replaced is 32½-in. scale measurement, and there are 42 teeth on the gear. What is the pitch?

7. What is the exact diameter the new gear should be turned?
8. Suppose you should measure across the diameter of the old gear and find that from the *bottom* of one tooth to the *top* of the opposite tooth was a trifle less than  $3\frac{1}{2}$  in. How would you find the pitch?
9. A machinist apprentice had to make two *10DP* gears, 20 teeth and 40 teeth, respectively. He turned the blanks to the correct outside diameters. What sizes did he turn them?
10. Then he got a No. 3 cutter *10DP* from the toolroom and cut both gears with this cutter. What mistake did he make?
11. However, the gear was not spoiled. Why not?
12. What is your understanding of the term *standard* as used in machine-shop practice?
13. What differences are usually to be found between the standard-tooth and the stub-tooth gear?

### BEVEL GEARS

One should have a working knowledge of the parts and principles of the spur gear before attempting to study the bevel gear. To anyone who has this knowledge of spur gears the subject of bevel gears should prove easy to understand, if studied step by step in logical sequence. This text is presented in the following order:

1. Preliminary discussion and definitions.
2. Instruction for laying out gears. A layout is advisable to fix in mind certain necessary knowledge as well worth while for the machinist as for the draftsman.
3. Definitions and rules, bevel-gear elements, and tooth parts.
4. Example showing application of the rules. Size of gear selected is the same as for layout (2).
5. Cutting a bevel gear in a milling machine.

Do not rush. Try to understand each step before proceeding to the next.

**Pitch Cylinders, Pitch Cones, Spur Gears, and Bevel Gears.** In the same way—as was explained in spur gearing—that the motion of one cylinder will cause motion in a parallel cylinder that touches it, motion may be communicated from one shaft to another at an angle to it (whose center lines would meet if sufficiently prolonged) by means of cones in close contact. The apex of each cone is

at a point where the center lines of the shafts would meet. Motion may be communicated in the desired velocity ratio (Fig. 11-22, *a* and *b*) and at the desired angle (*c*, *d*, and *e*).

In the study of spur gears it was learned that positive motion may be transmitted between parallel shafts by means of spur gears, and that spur gears are, in effect, "pitch cylinders" with teeth built on the cylindrical surfaces. Bevel gears are, in effect, "pitch cones" with teeth built on the conical surfaces.

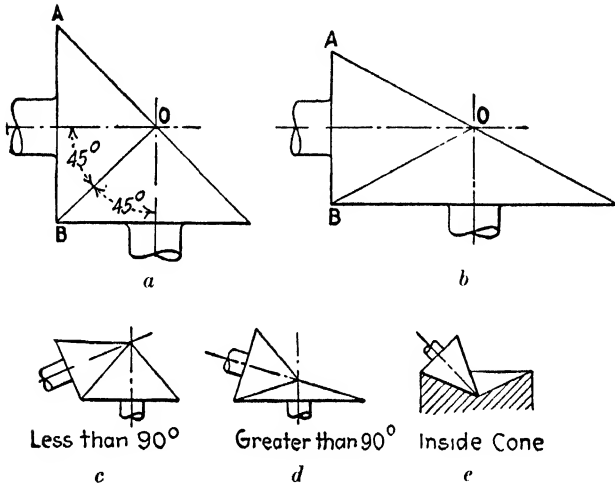


Fig. 11-22.

Spur gears communicate motion between parallel shafts. These shafts may be (within limits) any distance apart, and motion may be communicated (within limits) in any desired velocity ratio. Similarly, bevel gears communicate motion between shafts whose axes meet when prolonged.

In a pair of gears, spur or bevel, the smaller is often called the *pinion*.

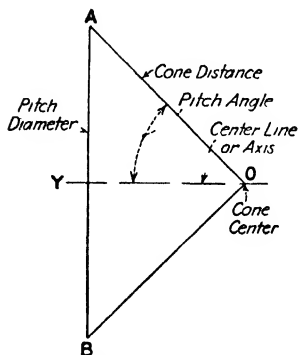
Bevel gears are called *miter gears* when they are of the same size and transmit motion at right angles.

*Pitch Cones.* The cones which represent in bevel gears the original friction surfaces are called the *pitch cones*. It is on frustums (portions

at the large end) of these cones that the teeth of bevel gears are built, similarly to the way the teeth of spur gears are built on the pitch cylinders.

It is important that one should have a very clear understanding of the elements of the pitch cone, for the reason that, although the bevel gear itself is only a portion of a cone, in drawings the whole cone is laid out and in calculations the whole cone is considered.

In the drawing (Fig. 11-23) the triangle  $AOB$  represents the pitch cone with the cone center at  $O$ . The line  $OY$  is the *center line* (axis) of the cone, and the lines  $OA$  and  $OB$  represent the *cone (apex) distances*. Either angle  $AOY$  or  $BOY$  is the *pitch angle*. The line  $AB$  will equal the *pitch diameter* of the bevel gear built on this cone.



**Fig. 11-23.** Elements of pitch cone. These elements apply to the bevel gear exactly as they apply to the pitch cone.

*Pitch Angle.* In any bevel gear, the angle that the cone distance makes with the center line is called the *pitch angle*. Figure 11-22a represents two shafts running at right angles with equal pitch cones. It will be noted that the pitch angle is one half of 90 deg. or 45 deg. It will be observed in Fig. 11-22b that in right-angle bevel gears, other than miter gears, the pitch angle

of either the gear or the pinion cannot be 45 deg. and that the pitch angle depends on the relative pitch diameters of the gear and the pinion. The pitch angle is one of the most important factors in bevel-gear calculations.

*Pitch Diameter.* When speaking of the pitch diameter of a bevel gear, the diameter at the large end of the pitch cone is meant. As a matter of fact, the diameter at any given point in the pitch cone is the pitch diameter of *that part* of the gear, but in practice no thought or consideration is given to any other pitch diameter than the largest in the gear.

*Face Width of Bevel Gear.* In making a bevel gear, the teeth are not cut on the whole pitch cone but only on a portion of it. The distance equal to the length of the tooth is called the *face width* of the bevel

gear (Fig. 11-24). The ends of the teeth are spoken of as the "large end" and the "small end."

In practice, the face width of the gear tooth is frequently shorter but never longer than one third of the cone distance. The dimension should be in sixteenths of an inch or greater, never in thirty-seconds or sixty-fourths.

*Cone Distance (Apex Distance), Tooth Size and Shape.* In any bevel gear of whatever diameter, angle, or face, the teeth and the spaces are largest at the largest diameter of the gear and decrease in size as the cone center of the original pitch cone is approached. If it can be imagined that teeth were cut along the whole pitch cone, halfway down the cone the teeth and the spaces would be half as large as at the large end and all would vanish at the cone center.

According to this reasoning, it will be clear that the sizes of bevel-gear-tooth parts, at the large end and at the small end, for example, are proportional to their respective cone distances. This proportion is used in practice (see rule for size of tooth parts at small end on page 377).

It will be understood that when the size of the tooth changes, the curve of the tooth also changes, and consequently it will be impossible to cut a bevel gear accurately with a rotary cutter because the cutting edge has a fixed shape and curvature. However, it is possible to mill a fairly accurate tooth shape by taking more than one cut, thus "trimming" the tooth, as will be explained later.

The drawing (Fig. 11-24) will serve to illustrate the principles thus far outlined of a bevel gear built on a cone. Let the triangle  $AOB$  represent the original pitch cone with a pitch angle of 45 deg. and a pitch diameter of 3 in. Suppose it is decided to put 30 teeth on this gear and to have the face one third of the cone distance. The module (gear 3-in. pitch diameter, 30 teeth) is  $\frac{1}{10}$  in., that is, the gear is 10DP. The cone distance  $OC$  is two thirds of the cone distance  $OA$  and consequently the module at the small end of tooth is two-thirds of the module at the large end of the tooth. That is, all the tooth parts, addendum, dedendum, thickness, at the small end of the

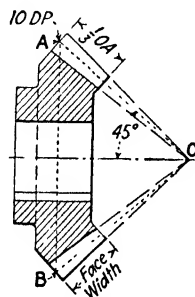


Fig. 11-24.



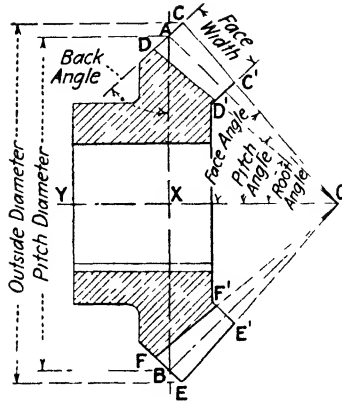


Fig. 11-25. Directions for laying out miter gear. Gear selected, 1 DP-20 teeth.

1. Draw center line  $OY$  and lay off  $OX$  equal to one-half pitch diameter =  $2\frac{1}{2}$  in.  $PD = \frac{N}{DP} = \frac{20}{4} = 5$  in.; one-half of 5 in. =  $2\frac{1}{2}$  in.)

2. Through  $X$  draw  $AB$  perpendicular to  $OX$  making  $AX$  and  $BX$  equal also to one-half of pitch diameter.

3. Draw  $OA$  and  $OB$ . These lines give size and shape of the pitch cone, and each is called the *cone distance*. Either cone distance with  $OX$  forms the *pitch angle* of the gear. (In this gear, and all miter gears, the pitch angle equals 45 deg.)

4. At points  $A$  and  $B$  draw lines  $CD$  and  $EF$  perpendicular to the cone distance lines  $OA$  and  $OB$ . These lines form with  $AB$  the *back angle*. In all

bevel gears, the back angle is equal to the pitch angle.

5. On line  $CD$  lay off points  $C$  and  $D$  distant from  $A$  equal to the addendum and the dedendum, respectively. (1 DP, addendum =  $\frac{1}{4}$  in.;  $AC = \frac{1}{4}$  in.; dedendum =  $\frac{1}{4}$  in. plus clearance = 0.289 in.;  $AD = 0.289$  in.)

6. Do the same at  $B$ . ( $BE = \frac{1}{4}$  in.;  $BF = 0.289$  in.)

7. Having decided on the *face width*, draw lines  $C'D'$  and  $E'F'$  parallel to  $CD$  and  $EF$ , respectively.

8. Draw  $CO$  and  $EO$ . These lines with  $OX$  form the *face angles* of the gear.

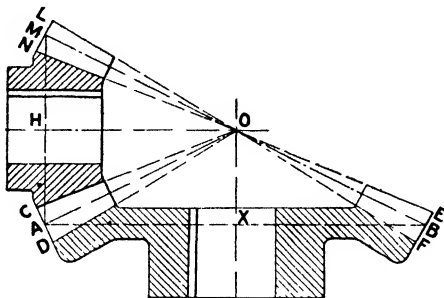
9. Draw  $DO$  and  $FO$ . These lines with  $OX$  form the *root angles* of the gear.

tooth will be two thirds as large as corresponding parts of the tooth at the large end.

**Laying Out Bevel Gears, Shafts at Right Angles.** Perhaps one of the best methods of becoming acquainted with bevel-gear parts and proportions is to lay out first a miter gear, then a gear and pinion. To get parts of miter gears to scale it is only necessary to draw one; to get the angles, proportions, etc., of the gear and pinion,

it is necessary to lay out both. It is usually best to make the drawings to a large scale if accuracy is required in measurements. In any event, in order to lay out bevel gears it is necessary to know *angle of shafts*, *numbers of teeth*, and *pitch of tooth*. Two examples with necessary directions follow (Figs. 11-25 and 11-26). Make these drawings full size or larger before proceeding further.

**Laying Out Bevel Gears, Shafts Not at Right Angles.** Bevel gears with shafts at other than right angles (Fig. 11-22, *c* and *d*) may



**Fig. 11-26.** Directions for laying out bevel gears, shafts at right angles. Gears selected: Gear 4 DP-24 teeth, pinion, 12 teeth.

1. Draw center lines of shafts at right angles intersecting at *O*.

2. Lay off *OH* equal to one-half pitch diameter of gear (= 3 in.) and lay off *OX* equal to one-half pitch diameter of pinion (= 1½ in.).

3. Through points *X* and *H* draw pitch diameters *AB* and *AM*, making *BX* = *AX* and *MH* = *AH*.

4. Draw *OA*, *OM*, and *OB*. These lines represent the pitch cones of the two gears. The point *O* of intersection of the lines *HO* and *XO* will also be the common point of intersection of all the lines *OL*, *ON*, *OC*, *OD*, *OE*, and *OF*, which are found and drawn the same as shown for miter gears (Fig. 11-26).

be drawn by the method shown in Fig. 11-26, except that the pitch diameters will not be at right angles to each other.

For example, if the angle of the shafts *HO* and *XO* (as in Fig. 11-26) were 80 deg. instead of 90 deg., simply draw pitch diameter *AM* of pinion at an angle of 100 deg. with the pitch diameter *AB* of gear and proceed as for regular bevels. (The smaller the shaft angle, the greater the distance *OX*.)

If the shaft angle is 110 deg., draw the pitch diameter *AM* at an angle of 70 deg. with pitch diameter *AB* and proceed as before.

The angle formed by the two *pitch diameters* will be just as many degrees less than 90 deg. as the shaft angle is over 90 deg., or just as many degrees over 90 deg. as the shaft angle is less than 90 deg.

**Calculations for Bevel Gears.** The outside diameter, the face angle, the root angle, etc., may be obtained fairly closely with a scale and protractor from a good drawing. They may be obtained also from tables of gear-tooth parts in handbooks, etc. These tables have been calculated by the use of rules, and in order to read the tables intelligently one should understand the rules. An example showing the calculations for a miter gear is given on page 377.

In order to calculate bevel gears, it is important to have a working knowledge of some of the functions of right triangles. If machinists realized how easily and quickly "shop trig" may be understood, more of them would spend a few hours in getting this understanding.<sup>4</sup>

*NOTE:* For trigonometric formulas and tables see pages 651 to 666.

**DEFINITIONS AND RULES: BEVEL-GEAR ELEMENTS AND TOOTH PARTS** (Fig 11-27)

Other gear terms common to both spur and bevel gears are defined beginning on page 356.

*Addendum.* Same as for spur gear, equals 1 divided by the diametral pitch.

*Addendum Angle.* The angle between the elements of the pitch cone and the face cone in a plane containing the axis of the gear.

**RULE:** The tangent of the addendum angle equals the addendum divided by the cone distance.

*Angles.* Addendum, back, dedendum, face, front, pitch, root, and shaft—see in alphabetical order according to name.

*Apex Distance.* See cone distance.

*Back Angle.* The angle between the plane of the pitch circle and a plane tangent to the large end of the tooth; equals the pitch angle.

*Back Cone.* The cone generated by revolving the back-cone radius about the axis of the gear.

<sup>4</sup> Any one of the following books will give the necessary information:

F. H. Colvin and F. A. Stanley, *American Machinists' Handbook*, 8th ed., McGraw-Hill Book Company, Inc., New York, 1945.

A. Axelrod, *Machine Shop Mathematics*, 2d ed., McGraw-Hill Book Company, Inc., New York, 1951.

*Treatise on Gearing*, Brown & Sharpe Manufacturing Company, Providence, R.I., 1951.

**Back-cone Radius.** The distance perpendicular to the pitch surface from the pitch circle to the axis; equals cone distance times the tangent of the pitch angle.

**Backing.** The distance parallel to the axis from the pitch circle to the face (end) of the shoulder or hub. (Do not confuse with crown backing.)

**Bore Diameter.** The diameter of the hole in the gear.

**Clearance.** Same as for spur gear.

**Cone Center.** The apex of the pitch cone.

**Cone Distance.** The distance from the cone center to any point on the pitch circle; equals one-half the pitch diameter divided by the sine of the pitch angle.

**Crown.** The circle formed by the intersection of the face cone and the back cone extended.

**Crown Backing.** The distance, parallel to the axis, from the crown to the shoulder or hub end. (Do not confuse with *backing*.)

**Crown Height.** The distance, parallel to the axis, from the cone center to the crown of the gear; equals the product of the cone distance times the cosine of the pitch angle, *minus* the product of the addendum times the sine of the pitch angle.

**Dedendum.** Same as for spur gear (usually 1.157 divided by the diametral pitch).

**Dedendum Angle.** The angle between elements of the pitch cone and root cone in a plane containing the axis of the gear. The tangent of the dedendum angle equals the dedendum divided by cone distance.

**Diameter Increment.** The amount added to the pitch diameter to obtain the outside diameter; equals two times the addendum multiplied by the cosine of the pitch angle.

(It will be observed in Fig. 11-27 that  $NC$ , the outside radius, is greater than  $XA$ , the pitch radius, by the length of  $KA$ , and *not* by the length of  $CA$ , the addendum. Do not add "two addendums" to the pitch diameter of a bevel gear.)

**Diametral Pitch.** Same as for spur gears; equals number of teeth divided by the pitch diameter.

**Face angle.** The angle between an element of the face cone and its axis; equals pitch angle plus addendum angle.

**Face Cone.** The right circular cone whose elements contain the top lands of the gear.

**Face Width.** The width of the pitch surface.

**Front Angle.** The angle between the plane of the pitch circle and a plane tangent to the small end of the tooth; equals the pitch angle.

*Heel.* A portion of the tooth at the large end; *toe* on the small end.

*Increment Angle.* See *Addendum Angle*.

*Module.* See page 354.

*Mounting Distance.* The distance, parallel to the axis, from the cone center to the shoulder or hub end against which the gear is mounted; equals crown backing plus crown height.

*Outside Diameter.* The diameter of the circle which contains the tops of the teeth; equals pitch diameter plus diameter increment.

*Pitch Angle.* The angle between an element of the pitch cone and its axis.

With shafts at right angles, the tangent of pitch angle of the *gear* equals number of teeth in gear divided by number of teeth in pinion, and pitch angle of *pinion* equals 90 deg. minus pitch angle of gear.

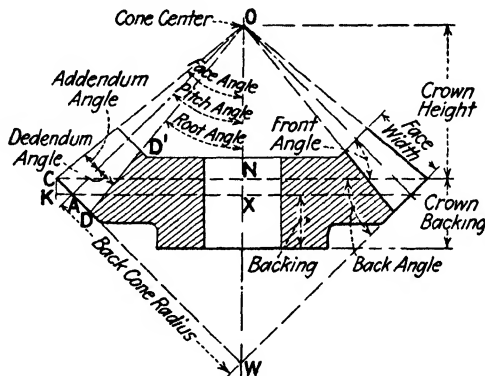


Fig. 11-27. Parts of a bevel gear.

*Pitch Circle.* The circle formed by the intersection of the pitch cone and a plane perpendicular to the axis. *Circumference* of pitch circle equals pitch diameter times 3.1416.

*Pitch Cone.* The cone generated by revolving the cone-distance line about the axis of the gear.

*Pitch Diameter.* The diameter of the pitch circle; equals the number of teeth divided by the diametral pitch.

*Root Angle.* The angle between an element of the root cone and its axis; equals pitch angle minus the dedendum angle.

*Root Circle.* The circle containing the bottoms of the tooth spaces.

*Root Cone.* The right circular cone whose elements contain the bottoms of the tooth spaces.

*Root Diameter.* The diameter of the root circle.

*Shaft Angle.* The included angle between the shafts upon which a pair of mating gears are to operate; equals the sum of the pitch angles of the two gears.

*Thickness, chordal, circular.* Same definitions as for spur gears.

*Toe.* A portion of the small end of the tooth *heel* on the larger end.

*Undercut.* See definition for undercut on page 359.

*Virtual Number of Teeth.* The number of teeth of a given pitch which would be contained in the *virtual pitch circle* whose radius is the back-cone radius.

**RULE.** Number of teeth for which to select the cutter for a bevel gear equals the number of teeth in the bevel gear divided by the cosine of the pitch angle.

*Size of Tooth Parts at Large Ends.* Same as for spur gear of same pitch.

*Size of Tooth Parts at Small End.* Divide the cone distance of small end by the cone distance of large end and multiply the respective tooth parts of large end by the quotient.

**Example Showing Calculations for Miter Gear.** Gear selected,  $ADP$ , 20 teeth (see Fig. 11-25). Use rules (*Definitions and Rules, Bevel-gear Elements and Tooth Parts*) as indicated by the terms introducing the calculations.

$$\text{Addendum} = \frac{1}{DP} = \frac{1}{4} \text{ in.}$$

$$\text{Dedendum} = \frac{1.157}{DP} = \frac{1.157}{4} = 0.289 \text{ in.}$$

$$\text{Pitch diameter} = \frac{N}{DP} = \frac{20}{4} = 5 \text{ in.}$$

$$\text{Pitch angle} = 45 \text{ deg. (45 deg. always in miter gears).}$$

Cone distance =  $\frac{1}{2}$  pitch diameter divided by the sine of the pitch angle =  $2.5 \text{ in.} \div 0.707 = 3.536 \text{ in.}$

Diameter increment = two times the addendum multiplied by the cosine of the pitch angle =  $2 \times \frac{1}{4} \times 0.707 = 0.3535 \text{ in.}$

Outside diameter = pitch diameter plus diameter increment =  $5 \text{ in. plus } 0.3535 \text{ in.} = 5.3535 \text{ in.}$

Addendum angle: Tangent of addendum angle equals addendum divided by the cone distance, equals  $\frac{1}{4} \text{ in.} \div 3.536 = 0.0707$ , which is tangent of angle  $4^{\circ}3'$ . Therefore addendum angle is  $4^{\circ}3'$ .

Dedendum angle: Tangent of dedendum angle equals dedendum divided by cone distance, equals  $0.289 \div 3.536 = 0.0817$ , which is tangent of angle  $4^{\circ}40'$ . Therefore dedendum angle is  $4^{\circ}40'$ .

Face angle equals pitch angle plus addendum angle  $45^{\circ}$  plus  $4^{\circ}3' = 49^{\circ}3'$ .

Root angle (cutting angle) equals the pitch angle minus the dedendum angle =  $45^{\circ}$  minus  $4^{\circ}40' = 40^{\circ}20'$ .

Size of tooth parts on large end are same as for spur gear of the same pitch.

Size of tooth parts at the small end: As one third of the cone distance (3.536 in.) is 1.179 in., let the face width of the teeth measure  $1\frac{1}{8}$  in. Then

$$3.536 \text{ in. minus } 1.125 \text{ in.} = 2.411 \text{ in.,}$$

which is the cone distance of the small end of teeth.

$$2.411 \div 3.536 = 0.682,$$

therefore multiply the parts of the tooth at the large end by 0.682 to obtain the sizes of the corresponding tooth parts at the small end. Addendum equals  $\frac{1}{4} \times 0.682 = 0.170$  in.

$$\text{Whole depth equals } \frac{2.157}{4} \times 0.682 = 0.367 \text{ in.}$$

Circular thickness equals  $\frac{1.57}{4} \times 0.682 = 0.267$  in.

Number of teeth for which to select the cutter for miter gear equals  $\frac{\text{number of teeth}}{0.707} = \frac{20}{0.707} = 28$ . (This is the same number of cutter as for a spur gear of 28 teeth, therefore the No. 4 bevel-gear cutter is used.)

**Cutting a Bevel Gear in a Milling Machine.** As previously stated, it is impossible to cut an *accurate* bevel gear in a milling machine. It often happens, however, that a bevel gear may be wanted in a hurry, or that an extremely accurate gear is not required, and it is then convenient to know how to mill one (Fig. 11-29).

*Selecting the Cutter.* In the study of spur gearing it has been learned that the same "form" of gear cutter—that is, the same number of cutter—is not used to cut a gear of 20 teeth that is used to cut a gear of 120 teeth. This is because the pitch surface of the 120-tooth gear

has a longer radius of curvature than the 20-tooth gear. In other words, it is more nearly straight.

Bevel-gear cutters are made in sets similar to spur-gear cutters with the same range of numbers of teeth to each cutter (see page 364). Bevel-gear cutters have a *curve of cutting edge* that is right for the large end of the tooth, but they are thinner than spur-gear cutters because they must pass through the spaces at the small end of the teeth. There is one feature in the selection of a bevel-gear

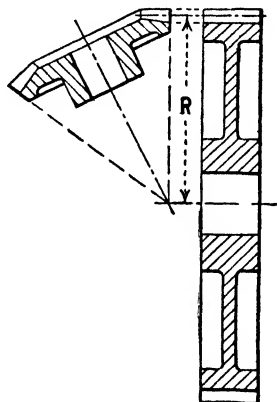


Fig. 11-28. Radius of rolling-pitch surface.

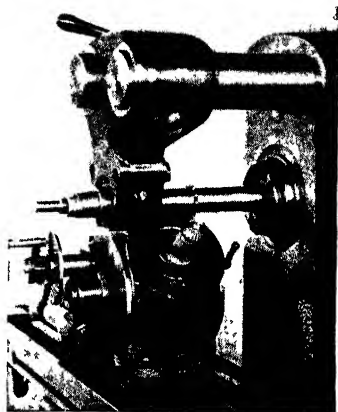


Fig. 11-29. Cutting a bevel gear in a milling machine.

cutter which at first seems difficult to understand; the cutter is not selected for the number of teeth in the bevel gear itself, but for a spur gear having a *pitch radius* equal to the *back-cone radius* of the bevel gear. For example, in Fig. 11-28 the number of cutter to select for the bevel gear would be determined by the number of teeth in the spur gear. The reason for this may be explained as follows:

The radius of the pitch surface of a spur gear is the same as the radius of the pitch circle of that gear, *but the radius of the rolling pitch surface of a bevel gear is longer than the radius of the pitch circle of that bevel gear.*<sup>5</sup> Thus in Fig. 11-28 the back-cone radius of the bevel gear is equal to the radius of curvature of the spur gear.

<sup>5</sup> The difference between the curvature of the *rolling pitch surface* of a bevel gear and the curvature of the *pitch circle* of that gear may be easily seen. Select a bevel gear (as large as 10 or 12 in. in diameter is best) lay a piece of paper along



The back-cone radius is not used directly in *calculating* the cutter to use (see rule below), but if a good drawing is furnished, it may be practically useful in determining the cutter, or in checking the calculation by the rule.

**RULE:** Number of teeth for which to select the cutter equals the number of teeth in the bevel gear divided by the cosine of the pitch angle.

*Order of Operations.* Let it be required to cut a bevel gear. The following directions in general will apply to any bevel gear; but select, for an example, say, a cast-iron gear of 24 teeth, *ADP* (Fig. 11-26). The data necessary to cut this bevel gear should be furnished with the order or on the drawing, but may be calculated, as previously explained. The sizes are as follows:  $DP = 4$ ; whole depth = 0.539 in.; circular thickness = 0.393 in.; addendum = 0.250 in. For small end of tooth, thickness = 0.267 in.; addendum = 0.170 in. The root angle (cutting angle) is  $50^{\circ}10'$ . Use No. 3 cutter.

**IMPORTANT PRECAUTION:** In any milling-machine indexing operation, the backlash or lost motion in the index-head worm and worm wheel, and in the feed screws, is a most serious consideration. *Do not neglect the lost motion.*

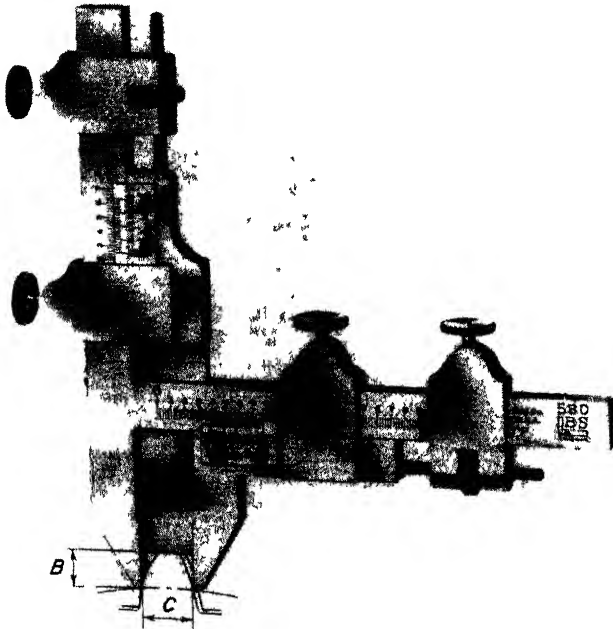
1. Check the measurements of the blank, especially the outside diameter and the face angle.
2. For 24 teeth, set the index pin in a circle divisible by 3. The largest circle is best to permit of finer adjustment for reasons hereafter explained (10). Set the sector to two thirds of one turn.
3. Set the dividing head to the root angle (equals  $59^{\circ}10'$ ).
4. Being careful that spindle, arbor, collars, and cutter are clean and that arbor runs true, set the cutter on the arbor so the direction of the cut will be away from the dividing-head spindle.

---

the outer edge of the teeth, in close contact against the edge of five or six teeth, and rub it to make an imprint of the teeth on the paper. Trim this paper to the pitch line of these teeth, and it will be cut to approximately the *curvature* of the *rolling pitch surface* of the gear. If, now, the paper is held at right angles to the center line of shaft, with the curve cut on the paper as nearly coincident with the curve of the pitch circle of the gear as possible, the difference between these curves will be apparent. The nearer the bevel gear approaches the spur gear—that is, the less bevel it has—the less is this difference.

Have the cutter as near the machine spindle as practicable and bring the work *central* under the cutter.

- Adjust the table until the revolving cutter just touches the gear blank at the *outside* diameter.

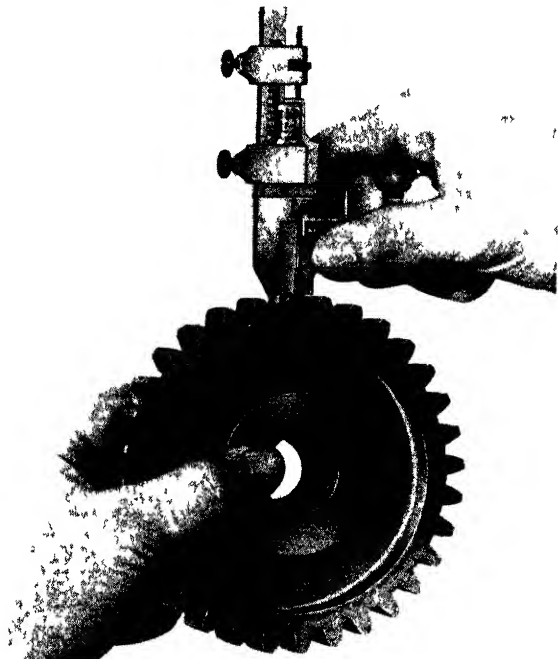


**Fig. 11-30.** Gear-tooth caliper—An almost indispensable tool if much gear work is done. Measures the chordal thickness  $C$  when set for the correct addendum  $B$ . (The Brown & Sharpe Manufacturing Company)

- Raise the table the whole depth (0.539 in.) and take a cut (perhaps a roughing cut will be advisable). Index for one tooth and take another cut.
- Measure the thickness of tooth, preferably with gear-tooth caliper (Fig. 11-30), at large end and at small end. (Fig. 11-31 shows the gear-tooth vernier in actual use.)
- Subtract the finished thickness of tooth ( $t = 0.393$  in.;  $t' = 0.262$ ) from the thickness as measured, and divide by 2 to know how much must be “trimmed” from each side ( $a$ , Fig. 11-31). Take

*both* halves away and the finished size will remain; take one half away and the size of tooth *when one side of the tooth is finished* will remain.

*NOTE:* There now are two spaces with a tooth between; the depth of tooth is established and the curve of the cutter is right for the large



**Fig. 11-31.** A gear-tooth caliper in actual use (*The Brown & Sharpe Manufacturing Company*)

end, but since the thickness of the cutter is about right for the finished space at the small end, the thickness of tooth at the large end is altogether too great. Since the curve of the cutter is correct for the large end of the tooth, the shape of the tooth at the small end is not right.

The job of cutting a bevel gear in a milling machine is to get the correct *thickness* of tooth, *at the pitch line*, at *both* ends of tooth by

trimming both sides of the tooth and then to file the small end to the correct curve (Fig. 11-32).

In any motion of a wheel on its axis a point on the rim passes through a greater arc, a greater distance, than a point on the hub. So, by the same principle, in any movement of a bevel gear or bevel-gear blank on its axis, the large end moves farther than the small end. That is, if the gear blank is revolved a very little (if the index pin is removed and advanced one or two holes on the plate), the tooth will be cut thinner, and a little more metal will be removed from the large end than from the small end, *but*, as it happens, *not enough in proportion*. If the gear is rotated, say, 5 or 6 holes in the

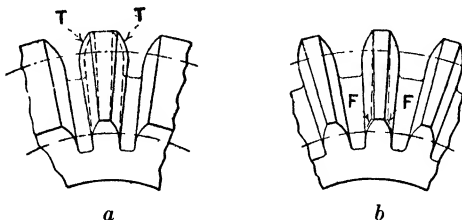


Fig. 11-32. Cutting a bevel gear: (a) trimmed with the cutter at *T* and (b) filed to correct curve at *F*.

39 circle, the large end may be right; but, the small end will be too thin. To avoid this, offset the blank; that is, move the table of the milling machine crosswise, bringing the gear tooth *away* from the cutter, and then *rotate* the gear tooth toward the cutter. This has the effect of taking more in proportion off the large end than off the small end.

To continue with the directions:

9. With blue-vitriol or dykem blue, paint the spaces cut; *take up the lost motion* in the cross-feed screw; set the dial at *O*, and, for a trial, offset the table about *one-seventh* the thickness of the tooth at the large end.
10. Pull out the index pin and rotate the blank until the large end of the tooth touches the cutter, and then *very carefully* (rotating the blank one hole (see 2) in index plate for each cut) *trim* the side of the tooth until the blue vitriol is nearly all cut off toward the small end.

11. Measure the thickness at the large end, and at the small end for sizes "*when one side is finished*" (see 8). If there remains more metal to be cut from the large end than from the small end, the blank must be offset a little more and the tooth trimmed again.
12. Having obtained the position of the blank to trim one side of the tooth for finish, *note the amount of offset and the number of holes which the blank was rotated.*
13. Index for the next tooth, take a cut, and so on, all around the gear blank, and there will be 24 teeth with *one side finished.*

*NOTE:* In a cast-iron gear of 5 pitch or larger or in a steel gear of 8 pitch or larger, it is usually advisable to take a *central* roughing cut or "stocking" cut before "trimming" either side.

14. Having finished one side of each tooth, offset the gear the same amount from center, being careful about the backlash, *in the opposite direction*, rotate the blank as many holes as noted (see 12) *in the opposite direction*, and carefully checking the measurements of first tooth (to finished size, see 8) proceed to trim the other side of each tooth.
15. File the small ends of teeth to size, as indicated at the lines marked *F* in Fig. 11-32.

*NOTE:* The amount of offset is from one seventh to one sixth of the thickness of the tooth at large end. In the above gear,  $4DP - 24$  teeth, it is about 0.060 in. In a  $12DP$  40-tooth *miler* gear it is about 0.018 in. In a pair of bevel gears,  $8DP$ , gear 24 teeth, pinion 12 teeth, offset for gear is 0.030 in., and for pinion 0.021 in.

*Too little offset leaves large end too thin.*

## QUESTIONS ON BEVEL GEARS

1. Look up the definitions of the words apex, cone, frustum, truncated.
2. Explain the following statement: A bevel gear may be said to be built on the frustum of an imaginary or theoretical cone.
3. Where is the center line of a bevel gear? The pitch diameter? The apex distance?
4. In shop drawings for turning bevel gears is it necessary to dimension the face angle? What angle does the face of the tooth make with the edge?

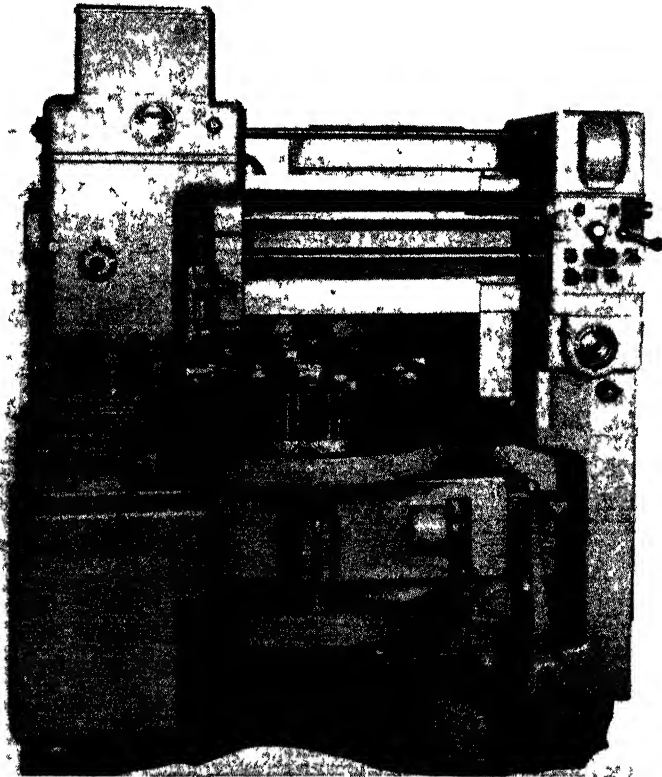
5. In order to turn up a bevel-gear blank in a lathe, is it necessary to know the outside diameter at large end of tooth? At small end?
6. What is the difference between the width of the face of a gear *tooth* and the width of the face of a *gear*?
7. Explain why and how the face width of a bevel gear should be dimensioned in a shop drawing.
8. Is the outside diameter of a bevel gear "two addendums larger than the pitch diameter?"
9. What do you understand by diameter increment?
10. Extreme care must be taken in setting any swiveling device—for example, compound rest in the lathe or dividing head in milling machine—not to cut the complement of the angle instead of the angle. This is especially true when the angle is only a few degrees more or less than 45 deg. How do you explain the reason for this precaution?

**Gear-generating Methods.** The tooth form which is now nearly always used for spur gears is the *involute*. The involute cannot be drawn in any such simple manner as the circle, and it is usually produced in practice by a *generated* process. In such a process, the cutting tool and the gear blank have regular motions, and the shape of the teeth produced in the blank depends upon these motions and upon the shape of the cutter. This is the underlying principle of all generating machines, such as the gear shaper and the gear hobber.

When a generating process is being used, only one cutter is required of each pitch to produce gears of any number of teeth of this pitch, and by the adopting of different blank diameters, a wide variety of tooth forms may be produced from the same cutter. Notice how different this system is from that used on milling machines to cut teeth. Here one milling cutter can cut teeth within a certain range and only of one pitch. A toolroom in such a shop using the milling machine to cut gears would have to stock many cutters to get a large variety of gears with different numbers of teeth and pitches. In the generating process, only one cutter is required of each pitch to cut many different gears of different numbers of teeth.

*Generation by Pinion-shaped Cutters.* Since all involute gears of the same pitch, circular thicknesses, depth, and pressure angle will mesh with one another and with a rack, it is possible to generate gears by use of a cutter in the form of a pinion.

The first machines to use this method of generation were those manufactured by the Fellows Company of Springfield, Vermont. An example is shown in Fig 11-33. The cutter is moved up and down parallel to the axis (center line) of the blank, in order to give the

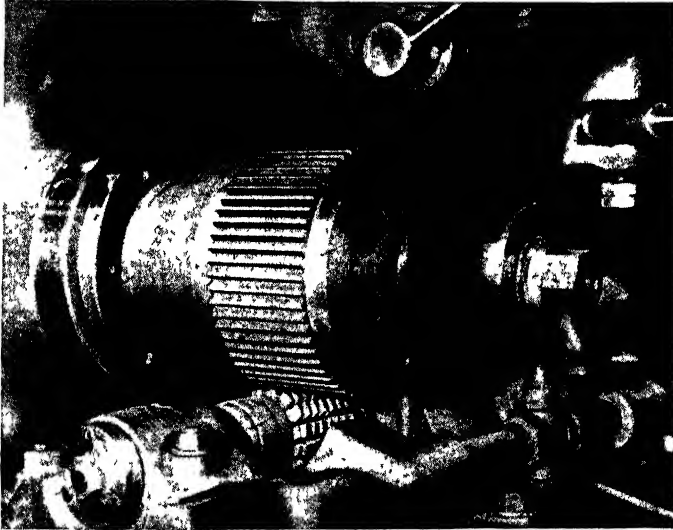


**Fig. 11-33.** Generating the teeth of a spur gear by the Fellows process, which uses a cutter in the form of a pinion (*The Fellows Company*)

cutting action, and at the same time the cutter and the blank are rotated at the feeds which gears of the same diameter would need to have in order to mesh correctly together. The actual speed of rotation is chosen so that the cutter removes a chip of suitable thickness at each stroke. On the up stroke, the cutter is automatically

moved slightly away from the blank, so that the teeth do not rub against each other. Indexing is also automatic and, when all the teeth have been cut to the proper depth, the machine automatically stops, indicating that the gear is completed.

An advantage of the Fellows process is that a gear of any diameter can be cut without the motions' being stopped, which is very necessary in machines of other makes.



**Fig. 11-34.** Hobbing a spur gear. The gashes or flutes of the hob form edges wherever they meet the thread which is relieved behind each edge. (*Barber-Colman Company*)

Pinion-shaped cutters with helical teeth may be used for generating helical gears. In that case, the cutter spindle works in a spiral guide, so that as the cutter moves downward, it also rotates through an angle which gives the required spiral form to the teeth that are cut in the blank.

*Generation by Hobbing.* The most accurate method of cutting gears is by the *hobbing* process (see Figs. 11-34, 11-35, and 11-36). The hob (Fig. 11-36) is a cutting tool in the form of a worm. Very often, as in Fig. 11-36, it is a single-thread worm, which is the same thing as a





Fig. 11-35. Hobbing a helical gear by the use of a worm-shaped hobbing tool (Barber-Colman Company)

spiral gear having one tooth and a spiral angle nearly equal to 90 deg.

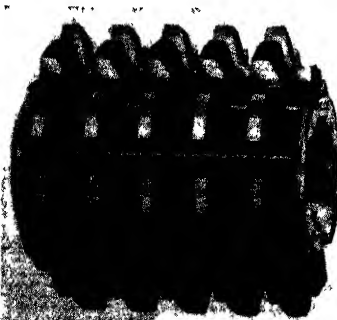


Fig. 11-36. Spur or helical gears are accurately cut by the use of the hob, a worm-shaped tool. (The Barber-Colman Company)

The hob is provided with *gashes* or *flutes*, forming edges wherever they meet the thread, which is cut away behind each edge. This cutting-away or *relieving* is done in such a way that the cutting edges may be sharpened by being ground on the radial faces without having the shape of the cutting edge changed. The hob may therefore be sharpened many times without losing its accuracy, even though its diameter is slightly reduced. The hob may be used to generate spur or helical gears by

setting the hobbing machine in the correct manner.

The hob is rotated at a rate which gives the cutting edges a suitable cutting speed, and the blank is rotated at the rate that the finished gear would have to mesh correctly with a single-tooth spiral gear similar to the hob, running at the speed of the hob. The hob is also fed slowly parallel to the axis of the blank, in order to cover the whole face width. If a helical gear is cut, the blank must have an additional rotation, to make up for this sliding of the hob across its face. A hobbing machine has no change in speed of any part, from the start of the cut to the end of it, and that is why

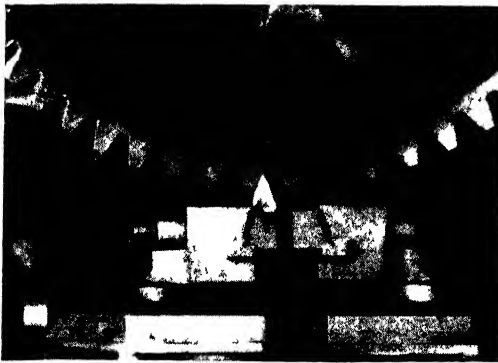


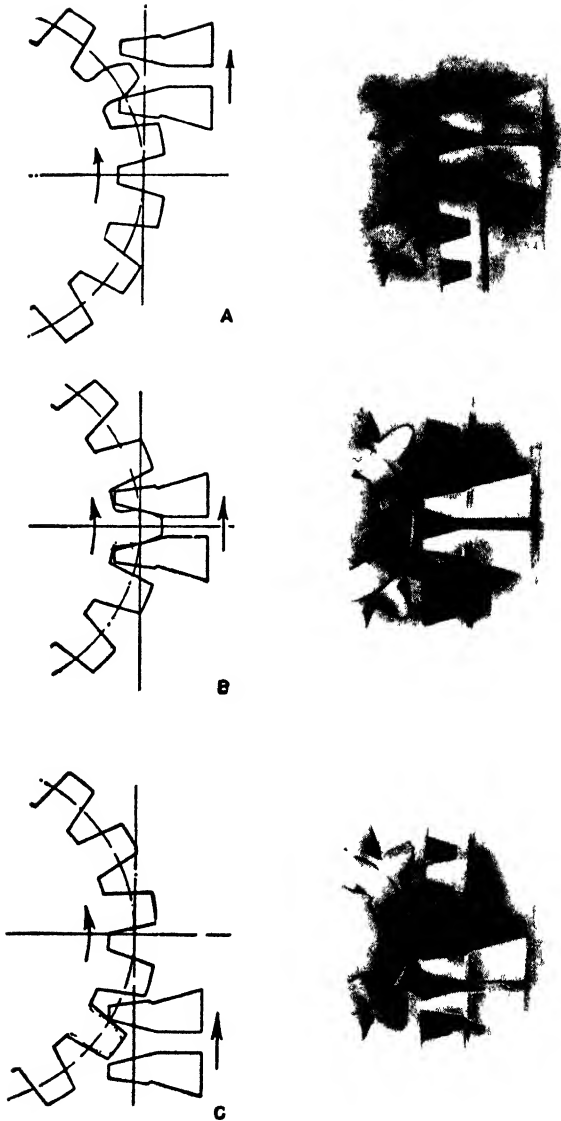
Fig. 11-37. Tools having straight cutting edges and, reciprocating on straight slides, generate the teeth of straight-tooth bevel gears (*The Gleason Works*)

hobbing gives more accurate work than does any other gear-cutting process.

The machine stops when the gear is finished.

*Bevel-gear Cutting.* Straight-tooth bevel gears are cut on bevel-gear generating machines. Two tools (Fig. 11-37) with straight cutting edges reciprocate on straight slides to generate the sides of the tooth. The tooth surfaces contain straight-line elements converging toward the apex of the pitch cone of the gear, and the curved profiles are the result of what is called a *generating motion* in the machine.

The effect of the generating motion on a previously roughed gear is illustrated in Fig. 11-38, where the tools start at the bottom position *A*, roll upward gradually through position *B*, and to top position *C*, while at the same time, the gear slowly rotates. It is seen that the sides of the tools correspond to straight sides of the teeth of an



**Fig. 11-38.** In generating a bevel-gear tooth, the cutting tools represent teeth of an imaginary crown gear that has a relative rolling motion with the gear being generated. (*The Gleason Works*)

imaginary flat gear—a crown gear—that would roll with the gear being cut. The principle illustrated here underlies the generation of tooth profiles in all types of gears.

A general view of a straight-bevel-gear generator is shown in Fig. 11-39. After the machine has been set up with the gear blank and tools in proper positions, the cutting operation is started and the

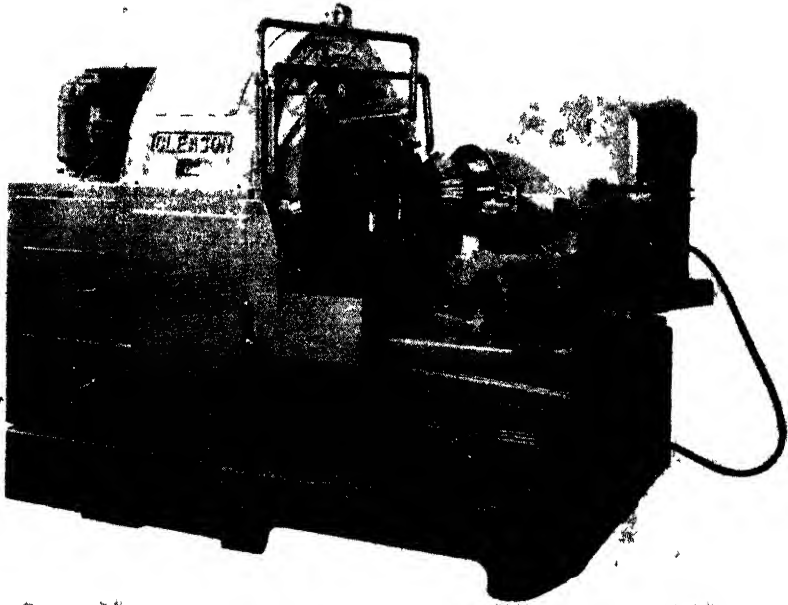


Fig. 11-39. Straight bevel-gear generator After the machine has been set up and started, the operation is wholly automatic (*The Gleason Works*)

machine works automatically, indexing from tooth to tooth, and stopping when the last tooth has been generated. Various sizes of straight-bevel-gear generators are built with some differences in design and type.

For spiral bevel gears in which the teeth are curved from end to end and inclined away from the axial direction, a rotating face-mill cutter (Fig. 11-40) is used, instead of reciprocating tools. Spiral-bevel-gear generating machines also are built in different sizes and

types. Some machines are designed for roughing out the blanks only, preparatory to finishing, and this decreases the cost of manufacture.



**Fig. 11-40.** A spiral bevel-gear cutter for spiral teeth that are curved and oblique across the face of the gear (*The Gleason Works*)

There are machines that finish-grind the sides of the teeth of a steel gear very accurately after it has been hardened.

# *The Grinding Machine*

---

## CHAPTER 12

---

### **Grinding-machine Construction**

A far greater advance in design, construction, and use has taken place during the past few years in the grinding machine than in any other machine-shop tool. Until recently the grinding machine was regarded as a toolroom machine, particularly useful only for finishing hardened steel. It is, however, now recognized as one of the most important machine tools for manufacturing purposes. This is owing to the remarkable development of the machine itself, and also of the abrasive wheels used, as the means of producing very accurate and beautifully finished surfaces, economically. The work may be of any of the metals used in machine construction, such as cast iron, wrought iron, bronze; also hardened or unhardened steel of whatever variety.

Perhaps because of its comparatively rapid development, grinding is one of the operations least understood by the otherwise well-informed machinist, and this fact should be an added incentive for the ambitious beginner to gain as much knowledge as possible of the grinding machine, the characteristics of the various abrasive wheels, and the methods employed in grinding. Manufacturers are very willing to send catalogues of their machines to foremen or instructors for the purpose of placing them in the hands of those interested. Articles on this interesting subject are frequently published in the trade journals. It is recommended that the beginner obtain and read a catalogue or, better still, an operator's manual and any other information he is able to get concerning the machine he is going to operate. He will thus acquire a broader understanding of that particular machine, besides general knowledge, since the basic principles of the essential mechanisms are practically the same in all grinding machines of a given type. The young man who will study and reason,

observe what others are doing, ask sensible questions, and take advantage of every chance for experience will soon get the information he is after.

The function of the grinding machine is, like every other machine tool, the removal of metal by means of a suitable cutting tool. For the same reason that there are various types of lathes, milling machines, drilling machines, etc., there are various types of grinding machines. Just as there are different shapes and kinds of milling cutters for various purposes, there are several shapes and a variety of kinds of grinding wheels.

The cutting tool used is a grinding wheel, or "abrasive" wheel, revolving at a high rate of speed. This wheel is made up of small sharp-edged fragments of a very hard substance cemented or "bonded" together. Very probably the boy in the shop as he sharpens a lathe tool or a drill in the grinder imagines that the wheel rubs off the steel. It may be that it does if the wheel is dull, that is, if the projecting edges have been rounded by continued grinding; but when the wheel is sharp it *cuts*. The chips are very small but they are real chips, nevertheless.

A few types of grinding machines are illustrated and briefly described.

Get acquainted with the machine you are running; learn the function of the various handwheels and levers, go back of the handles; find out what they operate. Adjust the feed for a given amount; study the feed mechanism. Learn how the stroke is adjusted for length and position and how it is reversed. Oil the machine carefully. As soon as convenient, learn how to adjust the wheel-spindle bearings. Unless these bearings are properly adjusted, poor grinding will result. The particular machine you are running may be all right, but what about some other? It is better to get information concerning elementary principles when you are recognized as a beginner.

**The Grinder in Mass-production Shops.** In mass-production shops, the efficiency of the assembly line is greatly affected by the accuracy and finish of the parts turned out in other departments. Rapid assembly depends upon the degree of accuracy with which tolerances are maintained in regular quantity output. Modern grinders are capable of holding extremely close tolerances and of maintaining

the necessary high standards of finish. They are, therefore, used extensively in metalworking industries.

Mass grinding of closely gaged parts is possible only on the most accurately built precision grinders. Many shops regularly maintain grinding tolerances to plus or minus one-half of one-thousandth of an inch ( $\pm 0.0005$  in.), and it is not unusual to meet, in regular production, tolerances of half such limits. Moreover, on a finish grind, it is quite possible to adjust the wheel so that it will spark out against the work (grind without any further feed of the wheel until sparks are no longer seen) without removing more than 0.00001 in. of metal.

Although accuracy of size is essential, finish is equally important. Irregularities on a ground, flat surface, amounting to only 0.00001 in., appear to the eye as wheel marks, and mar the finish. Many modern precision machines used for the mass production of metal parts grind with such accuracy that a new conception of measurement has resulted and a new term *micro-inch* (one-millionth of an inch) is now common in certain industries to describe surface finish.

To meet these exacting demands, grinders have been made heavier, to absorb vibration, and sturdier, to give greater rigidity. Bunning parts are delicately balanced and clearances are reduced to a minimum. Sliding surfaces are not only accurately ground, but are then lapped or honed to even better fits. Ways are as straight and as nearly parallel as it is possible to make them. The teeth of gears and the threads of lead screws are ground and lapped to perfect fits. When these machines leave the manufacturers' shops, they represent the attainment of the greatest possible accuracy and perfection. The maintenance of this accuracy and perfection in service depends upon the care given to these machines by the people who use them. They should be handled with great care and *must* not be abused in any way.

**Types of Grinders.** Grinders may be of the more or less roughing type, such as grindstones, bench grinders, flexible-shaft grinders, cut-off wheels, etc.; or they may be of the precision type, such as cylindrical grinders, tool and cutter grinders, internal grinders, etc.

A precision grinder comprises essentially a wheel head and revolving wheel spindle, on which the grinding wheel is mounted, and either a work head and revolving work spindle, or a reciprocating or revolving worktable. The wheel and its spindle revolve independ-



ently of the work, and the wheel head may be controlled by a traverse feed, an infeed, or both, depending on the type of machine. Work heads rotate the metal that is being ground. Reciprocating worktables draw the work back and forth across the face or flank of the revolving wheel. Revolving worktables carry the work under the revolving wheels. All types of worktables may be equipped with a traverse feed, an infeed (cross-feed), a vertical feed, or all three. All parts are actuated by mechanical, hydraulic, or electrical means.

Precision grinders may conveniently be classified in six groups;

*Cylindrical Grinders.* In these the abrasive wheel grinds a cylindrical, or modified cylindrical, surface as a reciprocating worktable, actuated by a traverse feed, draws the work longitudinally across the face of the wheel. The following types are common:

- Plain cylindrical grinders
- Roll grinders
- Piston grinders (traverse type)
- Universal grinders

*Plunge-cut Grinders.* In this group of grinders, the abrasive wheel grinds cylindrical, or modifications of cylindrical, surfaces when the wheel head, actuated by an infeed, moves into the rotating work. Among these are the following types:

- Ordinary plunge-cut grinders
- Crankpin grinders
- Piston grinders (plunge-cut types)
- Camshaft grinders

*Form Grinders.* In a form grinder the abrasive wheel, of *special shape*, actuated by an infeed and sometimes by a traverse feed, grinds a *formed* surface on revolving cylindrical blanks, the forms being determined by the shape of the wheel or by the relative movement of the wheel head and the work. The following types may be classed as form grinders:

- Ordinary form grinders
- Thread grinders
- Gear grinders

*Internal Grinders.* The abrasive wheel of an internal grinder, actuated by a traverse feed and an intermittent infeed, grinds internal surfaces of cylindrical, or modified cylindrical, shape on the rotating work. Two types are commonly seen:

Chucking grinders

Planetary-spindle grinders

*Centerless Grinders.* In a centerless grinder the work is traversed across the face of an abrasive wheel, being supported on a work-rest blade (instead of being held between centers or in a chuck) and rotated between the grinding wheel and a regulating wheel. The common types are:

External centerless grinders

Internal centerless grinders

*Surface Grinders.* A surface grinder is designed for the grinding of flat surfaces. These grinders may be classified as follows:

Surface grinders using the face of the wheel

Surface grinders using the flank of the wheel

In all types of grinders, suitable means is provided for the independent selection of cutting speed (peripheral speed of the grinding wheel), work speed (peripheral speed of the work), rate of table traverse (sweep of grinding wheel across the face of the work), and rate of wheel infeed (depth of cut).

While many of the above-mentioned machines will be briefly described and discussed, a detailed description and discussion will be given of the universal grinder.

## CYLINDRICAL GRINDERS

**Plain Cylindrical Grinders.** Plain cylindrical grinders (Fig. 12-1) are used for grinding the external surfaces of sleeves, pins, rods—in fact, all manner of parts where a true cylindrical or tapered (conical) surface is required. They range from light-duty to heavy-duty machines.

In this type of machine, two methods are used for holding the work. One is to clamp the work in a rotating chuck; the other is to rotate the work between center points, as shown in Fig. 12-2. In either case, the rotating work is reciprocated (traversed) across the face of a comparatively narrow abrasive wheel. After each table traverse, the wheel moves toward the work a distance equal to the depth of metal to be removed. Crossways under the wheel head provide for feeding the wheel a few ten-thousandths of an inch toward the work after each traverse of the worktable. The worktable is

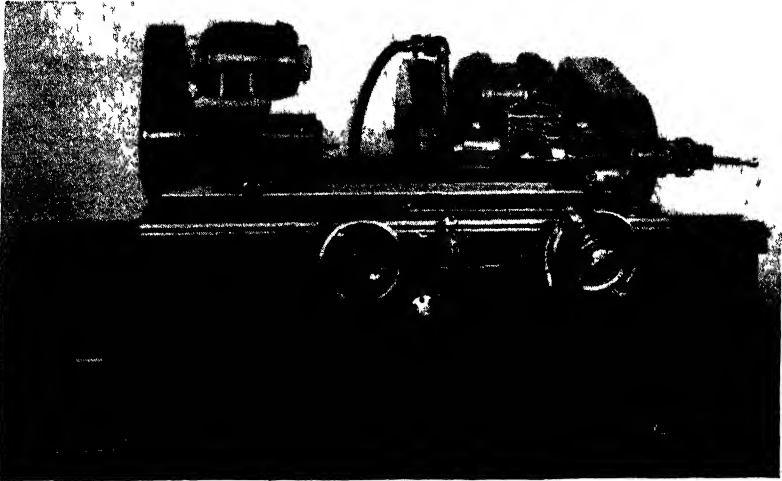


Fig. 12-1. A Norton 10- by 36-in. type C cylindrical grinder (Norton Company)

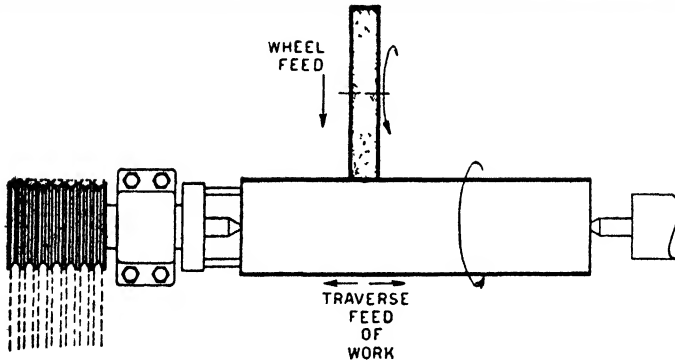


Fig. 12-2. Work held between centers in cylindrical grinding (The Socony-Vacuum Oil Company)

driven by an electric motor mounted with the head on the reciprocating worktable. A similar self-contained motor drives the grinding wheel.

**Roll Grinders.** Cylindrical grinders have been adapted to the special service of grinding large, heavy rolls, such as are used in steel mills, paper mills, printing plants, etc. These rolls may be of steel, chilled cast iron, copper, brass, hard or soft rubber, etc. Accurate

size and exceptionally high finish are required and, in many cases, the surfaces of the rolls must be highly polished, often with mirror-like finish. Figure 12-3 shows an operator grinding such a roll.

Roll grinders are heavy-duty machines, capable of handling unusually heavy work. For example, the steel rolls used in a paper mill may have a diameter of 36 in., a length of 33 ft. or more, and a weight of 55 tons.



Fig. 12-3. Action view of operator grinding a large roll. (Norton Company)

The length and weight of these rolls introduce two slight deviations from ordinary cylindrical grinding: First, journal rests are provided to carry the weight of the roll after it has once been centered on the machine. Second, a mechanism is provided for automatically moving the wheel head slightly away from, and then toward, the roll as the wheel feeds longitudinally across its face, thus giving the roll a slight crown, to compensate for sag caused by weight and pressure when it is placed in service.

**Piston Grinders.** The grinding of pistons of high-speed internal-combustion engines frequently constitutes another deviation from plain cylindrical grinding. Many such pistons are not ground truly

cylindrical but slightly elliptical, being undersize on the diameter through the piston pin. Moreover, they are sometimes slightly tapered; that is, they are smaller in diameter at the top, where the greatest expansion will occur when they are exposed to the heat of combustion in the engine cylinder.

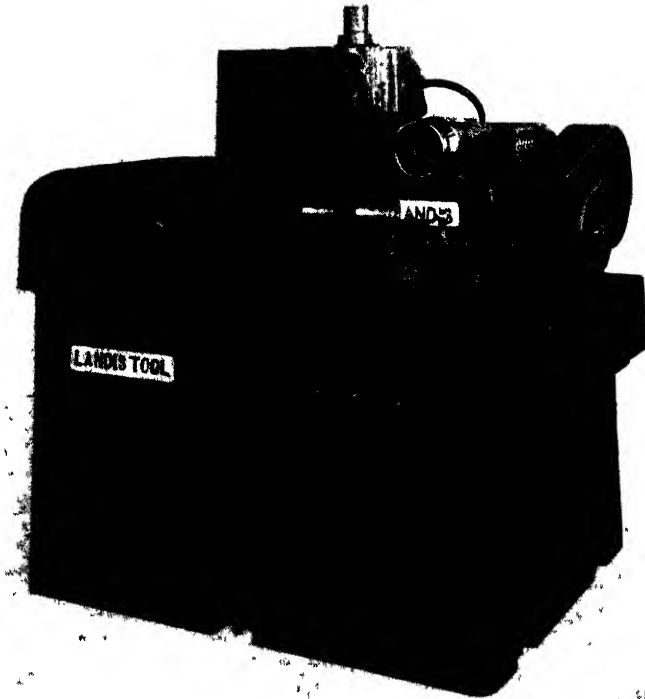


Fig. 12-4. Hydraulically operated piston grinding machine used for cam-grinding the skirt portion of a piston. (*Landis Tool Company*)

On a piston grinder, therefore, a mechanism is provided for automatically and synchronously moving the revolving piston alternately toward and away from the wheel, thus grinding an elliptical form; and at the same time, moving the work progressively away from the wheel during its longitudinal travel, thus grinding the desired taper.

In the piston grinder shown in Fig. 12-4, the work is mounted between a headstock fixture and a tailstock center point. These work-holding heads and the driving parts are mounted in a rocking cradle, which is controlled by a master cam. As the work rotates, the master cam rocks the cradle, thus grinding the work to a slightly elliptical shape. The worktable carrying the cradle traverses on slides extending the length of the machine. The table may be swiveled to grind a taper instead of a true cylinder.

**Universal Grinders.** Fundamentally, universal grinders (Fig. 12-5) are plain cylindrical grinders that have been adapted to handle the greatest possible diversity of work. They commonly serve as internal and surface grinders, as well as cylindrical, plunge-cut, and form grinders. Consequently, these machines are widely used in toolrooms for grinding tools, etc. They are frequently used where special parts are machined in small lots.

**Setup Adjustments and Operating Controls of the Brown & Sharpe Universal Grinder.** Some of the principal setup adjustments and operating controls are explained in the following sections. Study the illustrations very carefully to note the positions of the parts.

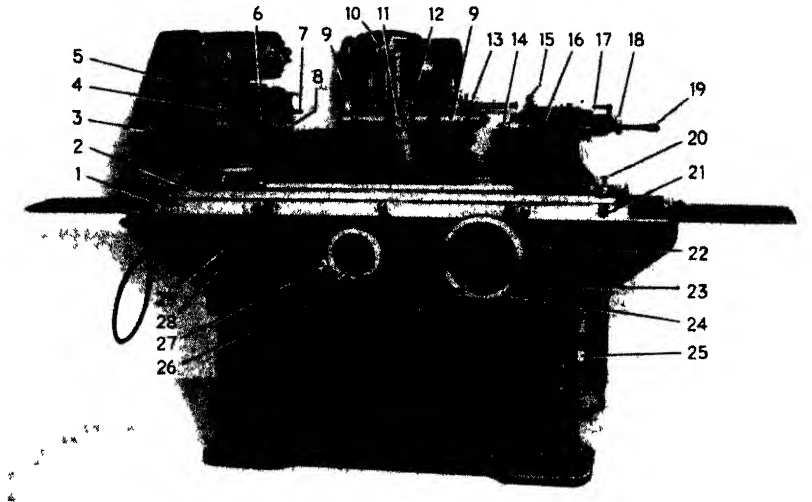
*Wheel-stand Assembly* (Fig. 12-6). The wheel stand which supports the wheel spindle and the wheel-spindle motor is adjustable along the platen, to which it is secured by bolts in both platen T slots. The stand is used most often in a forward position on the platen, but sometimes it must be moved back during the grinding of large diameters and in face-grinding with the face chuck. This permits a wide range in the center-line distance between the center line of the spindle and the center line of the work.

The wheel may be mounted between the bearings or at either end of the spindle. Great care must be taken in the mounting of a wheel and this should be done carefully, very carefully.

The spindle-driving motor is attached to a plate adjustable along the stand to regulate the tension in the driving belts. Adjustments are made by a screw knob directly connected at the rear of the motor plate.

*Internal Grinding Fixture* (Fig. 12-7). This fixture is used with the Universal grinder to do internal grinding jobs. The fixture is held in place on the rear of the platen by a single bolt, which allows it to be

swiveled slightly. It is usually left mounted with the belt removed from the motor pulley. To bring the fixture into operating position, the platen is swung halfway around (180 deg.). Guide lines (for matching) on the side of the platen and the slide help in the align-



a Front View

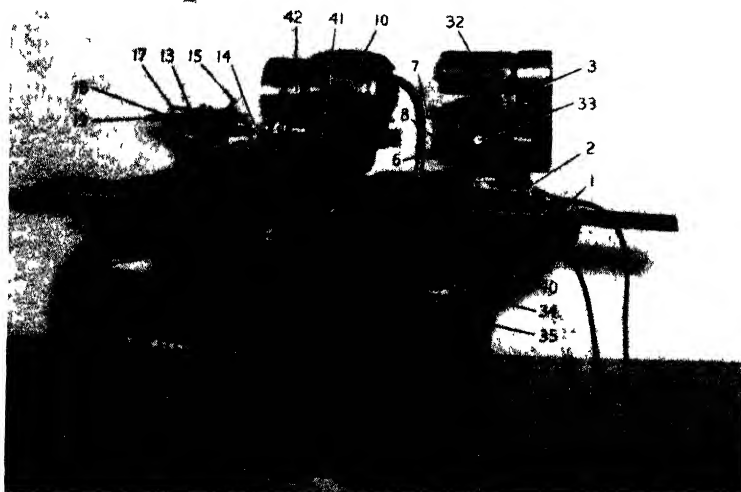
- |                                 |   |
|---------------------------------|---|
| 1. Sliding table                | 13 Internal grinding fixture            |
| 2. Swivel table                 | 14 Footstock center                     |
| 3. Spindle-drive belt guard     | 15 Diamond toolholder clamp             |
| 4. Tension adjustment           | 16 Spring pressure-adjusting nut        |
| 5. Belt-tension release lever   | 17 Footstock-spindle clamp              |
| 6. Headstock spindle-belt guard | 18 Spindle-adjusting knob               |
| 7. Work driving pin             | 19 Footstock-operating lever            |
| 8. Headstock center             | 20 Swivel-table locking pin             |
| 9. Wheel-spindle bushing        | 21 Swivel-table adjusting nut and scale |
| 10. Wheel-spindle motor         | 22. Table-feed engagement lever         |
| 11. Coolant nozzle              | 23 Table-motor selector-switch knob     |
| 12. Grinding wheel              |   |

Fig. 12-5. The Brown & Sharpe No 2 universal grinder.

ment. Drive is by flat belt from the driving pulley on the motor shaft.

**Headstock** (Fig. 12-8). This unit can be moved longitudinally along the swivel table and is clamped in position by two bolts, one on either side of the base. It is aligned by the front lip of the base, which bears for its entire length on the front edge of the table.

Start-stop and jog control is by means of a knob on the top of the main motor-switch control box at the left front of the machine bed. Turning the knob to the right starts the headstock motor, and hence the spindle; while turning it to the left stops the motor. A spring-



b. Rear View

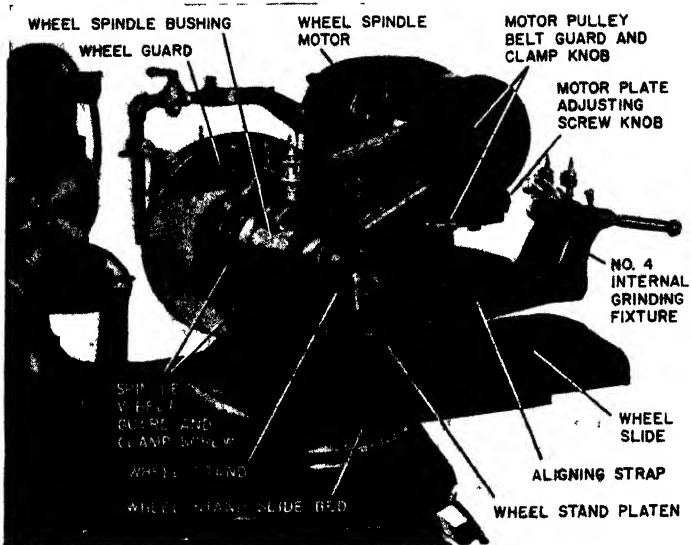
- |  |  |
|--|--|
| 24. Table handwheel                      | ing  |
| 25. Lower table-feed cone pulley         | 34. Coolant-pump disconnect plug             |
| 26. Cross-feed handwheel                 | 35. Motor-driven centrifugal coolant pump    |
| 27. 4:1 ratio cross-feed engagement knob | 36. Coolant tank                             |
| 28. Main push-button switch              | 37. Two-speed gear-head table motor          |
| 29. Headstock start-stop and jog control | 38. Table-reversing mechanism                |
| 30. Table reverse lever                  | 39. Counterweight-adjusting screw            |
| 31. Table reverse dog                    | 40. Pan water guard                          |
| 32. Headstock motor                      | 41. Motor-plate adjusting-screw knob         |
| 33. Spindle lock for dead-center grind-  | 42. Internal-grinding-fixture driving pulley |

(The Brown & Sharpe Manufacturing Company)

operated brake, integral with the motor, stops the work rotation quickly.

**Footstock** (Fig. 12-9). Like the headstock, this unit can be moved longitudinally along the swivel table and is clamped in position by a single bolt in the center of the base. To assure alignment with the headstock, the front lip of the base should bear for its entire length





**Fig. 12-6.** Wheel-stand assembly of a No. 2 Brown & Sharpe universal grinder (*The Brown & Sharpe Manufacturing Company*)



**Fig. 12-7.** Internal grinding fixture in grinding position on the platen. (*The Brown & Sharpe Manufacturing Company*)

on the front edge of the table. The operating lever at the right is used to retract the center from the work.

The spindle has a No. 9 Brown & Sharpe taper hole. The center has a 60-deg. point and can be driven from the spindle by a knockout

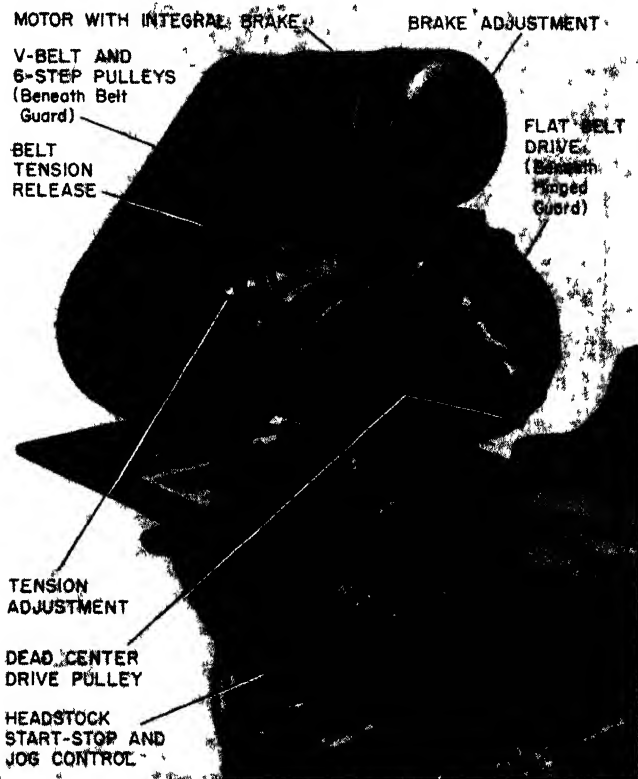
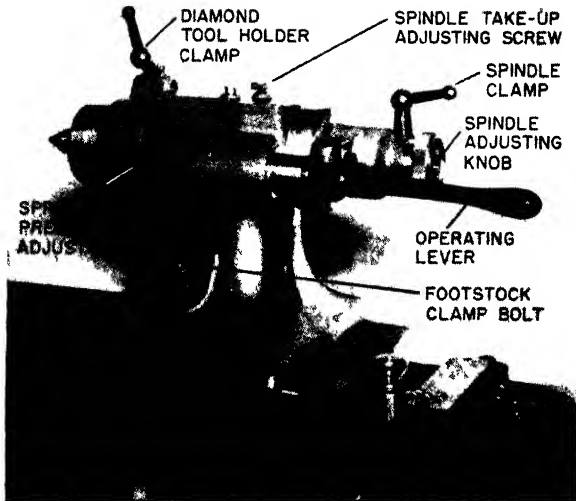


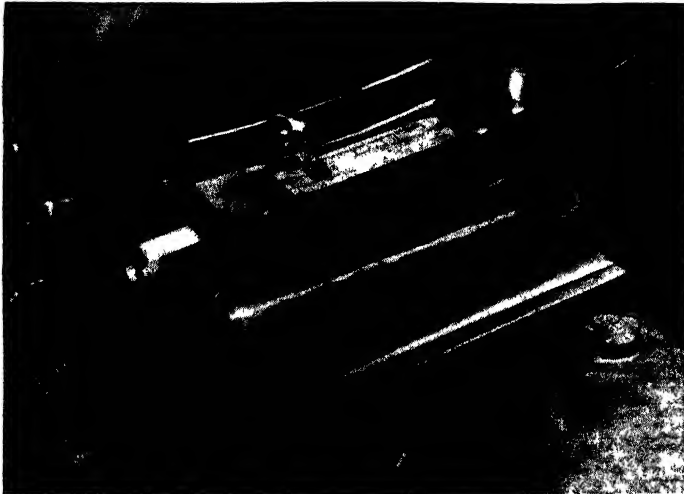
Fig. 12-8. The headstock of a Brown & Sharpe No. 2 universal grinder. (*The Brown & Sharpe Manufacturing Company*)

rod inserted through the right end. The bracket and clamp at the left end are for the diamond toolholder ordinarily used in truing the wheel.

*Swivel Table* (Fig. 12-10). The swivel table pivots about a central stud and is clamped to the sliding table by a clamp bracket and two bolts at each end.



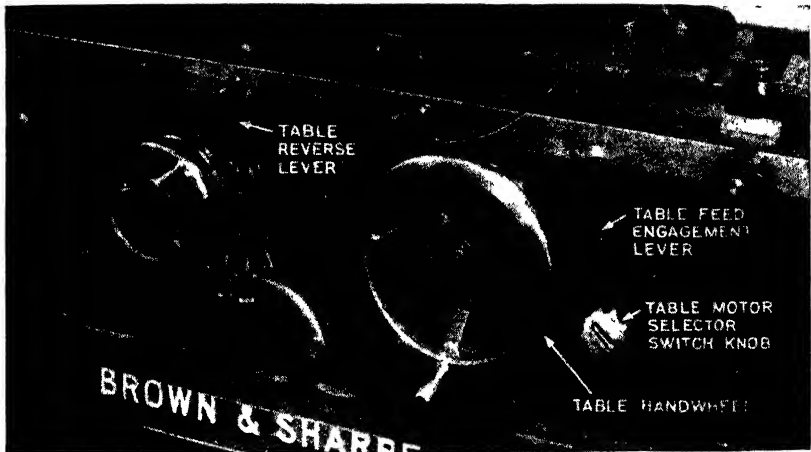
**Fig. 12-9.** The footstock of a Brown & Sharpe No. 2 universal grinder (*The Brown & Sharpe Manufacturing Company*)



**Fig. 12-10.** The swivel table of a Brown & Sharpe No. 2 universal grinder. (*The Brown & Sharpe Manufacturing Company*)

A plate on the right-hand clamp bracket has three graduated scales for setting the table at an angle to grind slight tapers. The inner scale gives the taper in degrees and reads half the included angle by 5-min. graduations; the middle scale gives the taper in inches per foot and reads the included angle by sixteenths-of-an-inch graduations; and the outer scale gives the taper in per cent and reads the included angle by half-per cent graduations.

To facilitate setting the table at an angle, there is both a coarse and a fine adjustment.



**Fig. 12-11.** Sliding-table setup adjustments and operating controls of a Brown & Sharpe No. 2 universal grinder (*The Brown & Sharpe Manufacturing Company*)

*Sliding Table* (Fig. 12-11). The table is driven through a rack and pinion, either by hand or by power. When it is driven by power, adjustable dogs act to stop the table and reverse it automatically at the end of each stroke. For hand-table travel, pull out the lever at the right edge of the handwheel. This engages the handwheel and disengages the power feed.

Before running the power-table travel, it is advisable to set the table reverse dogs to prevent any mishap. To set the table dog, lift the pawl in back of the knurled check nut and adjusting screw, and slide the unit to its approximate working position. Engage the pawl with the rack.

*Cross Feed* (Fig. 12-12). This mechanism can be operated (1) manually to move the wheel both to and from the work and (2) automatically, during external grinding, to feed the wheel toward the work as the table traverses.



**Fig. 12-12.** Cross-feed adjustments and operating controls of a Brown & Sharpe No. 2 universal grinder (*The Brown & Sharpe Manufacturing Company*)

Turning the handwheel counterclockwise feeds the grinding wheel toward the work during external grinding, and away from the work during internal grinding.

### PLUNGE-CUT GRINDERS

**Ordinary Plunge-cut Grinders.** For certain classes of work, the traverse feed of plain cylindrical grinders is not required, merely the infeed, which “plunges” the wheel directly toward the revolving work. To eliminate wheel marks on the work, however, the spindle is sometimes given, in addition to its infeed, a very slight longitudinal reciprocating motion. Over-all accuracy depends on the trueness of the surface of the grinding wheel.

Since small grinding wheels wear rapidly and quickly lose their accuracy, plunge-cut grinders usually have large wheels, up to 3 ft. in diameter.

Figure 12-13 illustrates the principle of plunge-cut grinding. Crankshaft grinding is an excellent example of the work done by such a grinder. In grinding the main journals, the width of the wheel is limited by the bosses and cranks on each side of the main bearings. Cross-feed of the wheel, without traverse feed of the work, is used. In order to minimize wheel marks on the finished journals, the wheel is given a slight longitudinal reciprocating motion.

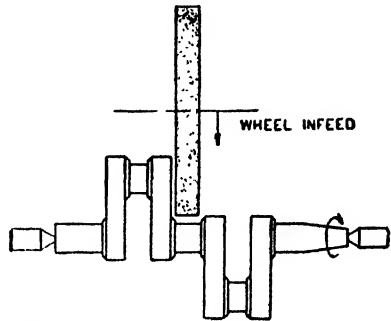


Fig. 12-13. Grinding a crankshaft. (The Socony-Vacuum Oil Company)

**Crankpin Grinders.** Plunge-cut grinders have been adapted for grinding crankpins of automobile engines, aircraft engines, diesel engines, compressors, etc.

Figure 12-14 illustrates the method used in crankpin grinding. The crankshaft is held at each end in offset clamps, which are

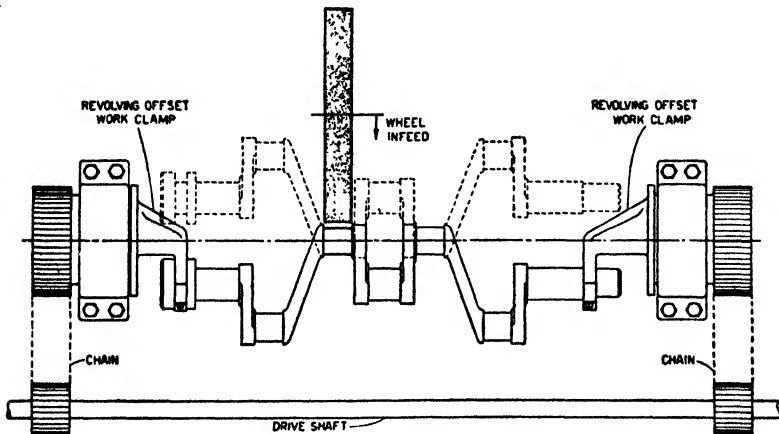
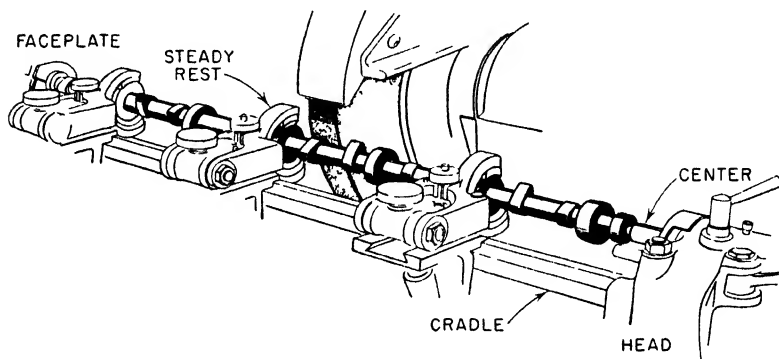


Fig. 12-14. Crankpin grinding. (The Socony-Vacuum Oil Company)

revolved in perfect unison by means of sprockets and chains from the same drive shaft. The crankshaft is thus rotated around the axis of the pin that is being ground. In some cases, the grinding wheel is

slightly narrower than the pin and the wheel spindle is reciprocated longitudinally the full length of the pin. In other cases, the grinding wheel is just wide enough to cover the length of the crankpin and is fed slowly toward the work without traverse motion. Large wheels, up to 42 in. in diameter, are used, thus reducing wheel wear and making it possible to hold an accurate wheel surface without excessive use of the diamond truing tool.

**Camshaft Grinders.** Camshafts of gasoline and diesel engines are ground on special camshaft grinders. These machines are modified plunge-cut grinders, in which master cams are provided to



**Fig. 12-15.** Camshaft grinding (*The Socony-Vacuum Oil Company*)

regulate the position of the work and thus generate automatically the profiles of the various cams.

Figure 12-15 shows a typical setup for camshaft grinding. The camshaft is supported between centers and is keyed in accurate position to a driving faceplate at the headstock end. Usually one or more steady-rests support the shaft at convenient intervals and eliminate any tendency to spring away from the wheel. The entire worktable assembly (headstock, drive, faceplate, steady-rests, and tailstock) is mounted on a cradle that rocks toward and away from the wheel, to generate the proper cam profile. The motion of the cradle is controlled by large master cams, which rotate in unison with the work. Longitudinal slides under the worktable permit the work to be moved from cam to cam, and cross slides provide for feeding the wheel directly toward the work. For each different cam on the shaft there is a separate master cam. As the worktable is

indexed from cam to cam, the proper master cam automatically assumes control of the rocking cradle. After moving to the proper position for each cam, the wheel moves rapidly into grinding position, slows to grinding feed, and continues feeding until the finished size is reached.

Diamond truing is done once per camshaft, at which time an automatic readjustment of wheel feed is made to compensate for the decreased wheel diameter. As each cam is finished, the wheel backs away from the work, the rocking cradle tips back to clear the master cams and the worktable shifts longitudinally into position for the

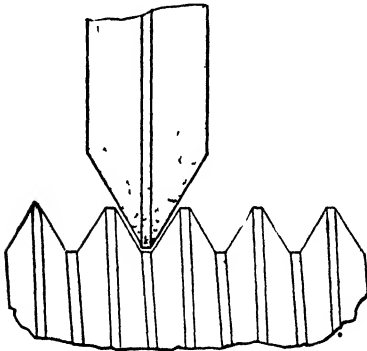


Fig. 12-16. Thread grinding (*The Socony-Vacuum Oil Company*)

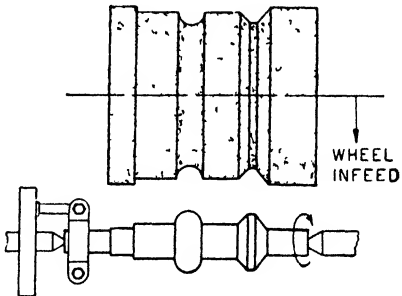


Fig. 12-17. Form grinding (*The Socony-Vacuum Oil Company*)

next cam. At the same time, the master-cam mechanism makes a corresponding shift. When the last cam is completed, the table returns to the starting position, the wheel is trued in preparation for the next piece of work, and the machine stops. Except for loading and unloading, the entire operation is automatic.

**Thread Grinders.** A special form grinder is used for the grinding of extremely accurate threads. American National, Whitworth, Acme, worm—in fact, threads of any form (either external or internal) may be ground on these machines, either from a blank, or as a finishing operation after milling. Parts may be ground either before or after hardening.

In thread grinding (Fig. 12-16), the profile of the grinding wheel depends upon the shape of the thread to be ground. The wheel is so formed as to have the exact shape of the thread.



In form grinding (Fig. 12-17), a formed wheel feeds toward the revolving work, which does not traverse. Here, too, the wheel has the exact shape and form of the profile to be ground.

**Gear Grinders.** When absolute accuracy is required in gears, the teeth of cut gears are ground after heat-treatment. In some instances, the teeth are ground, instead of being cut, from the rough blank. In order to secure perfect tooth form, extreme precision is necessary in the relative movements of the gear, the wheel head, and the work-

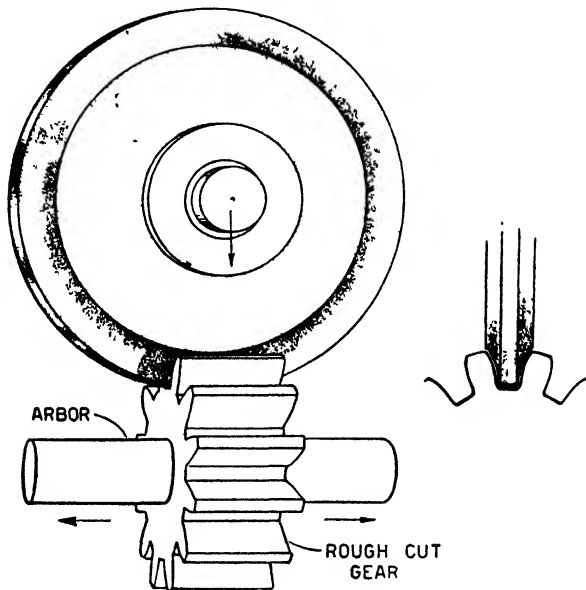


Fig. 12-18. Gear grinding. (*The Socony-Vacuum Oil Company*)

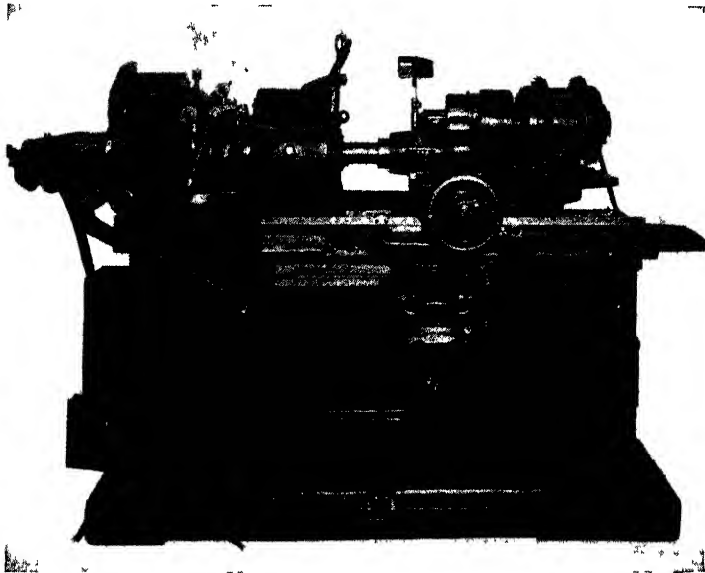
table. Gear grinders, therefore, must operate without the slightest end play, backlash, vibration, or other evidences of wear.

One method of grinding gears (Fig. 12-18) makes use of a formed wheel, shaped exactly to the profile of the space between two adjacent teeth. This curved profile varies for each change in gear diameter or for each change in the number of teeth. Such a profile is difficult to form and difficult to maintain accurately. A machined gear is mounted on an arbor and the arbor is held in an indexing and locking work head. With the gear locked in position, it is traversed

under the wheel by slowly reciprocating the entire worktable. At proper intervals, the indexing head shifts the gear from one tooth position to the next. Meanwhile, the wheel slowly lowers, until the full depth of each tooth is secured.

### INTERNAL GRINDERS

These machines are used chiefly for finishing round holes. On some makes, the work revolves, and holes of any size (within the



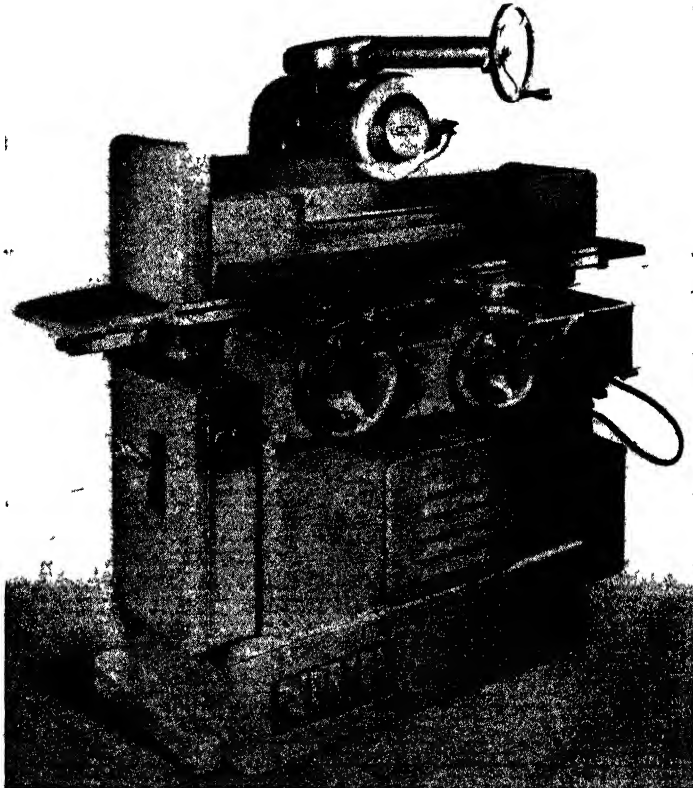
**Fig. 12-19.** An internal grinder

limits of the machine), straight or tapered, may be finished in such parts as gears, bushings, cutters, gages, etc. In general, small wheels are used. Diameters of 1 or 2 in. are common, although on rare occasions pencil wheels as small as  $\frac{1}{8}$  in. or  $\frac{1}{16}$  in. in diameter may be used. Frequent truing is customary for maintaining the accuracy of ordinary wheels; in fact, many internal grinders have automatic mechanisms that true the wheel for each piece. Usually this mechanism comes into action just before the final finishing strokes of the wheel. Figure 12-19 shows an internal grinder.

There are three general types of internal grinders: *chucking*, in which the work is held in a chuck, *planetary spindle*, in which the wheel spindle not only rotates but revolves about an axis and thus maintains contact between the wheel and work, and *centerless*, in which the usual chuck for holding the work is eliminated. This type of grinder is described in detail in Chapter 14.

### SURFACE GRINDERS

These are machines for grinding flat surfaces. There are two distinct types of surface grinders, *horizontal-spindle* (Fig. 12-20) and

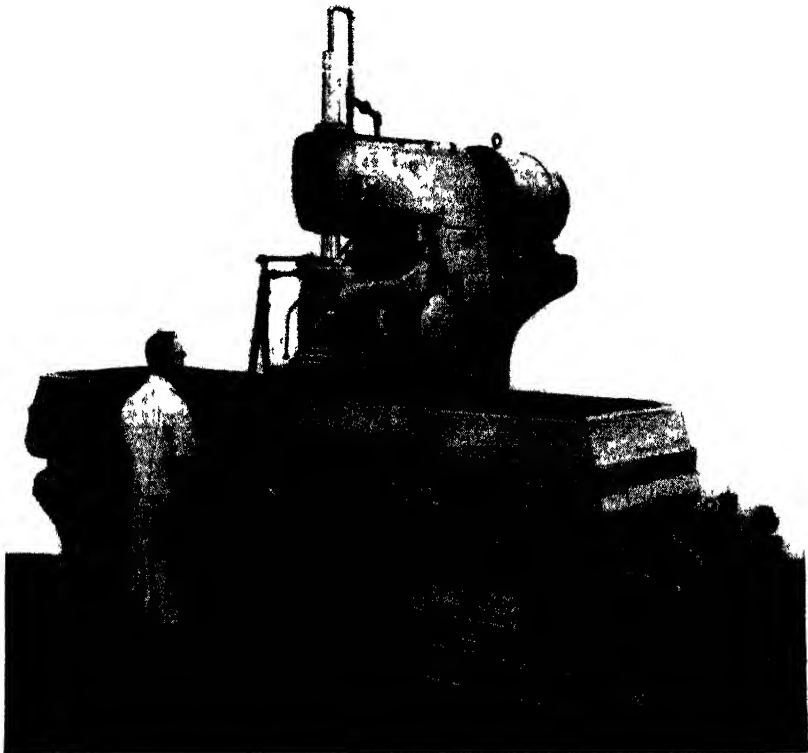


**Fig. 12-20.** A Norton 8- by 24-in.-hydraulic surface grinder. (Norton Company)

*vertical-spindle* (Fig. 12-21). Surface grinders are primarily for the purpose of finishing pieces that have previously been roughed on the shaper or the milling machine, but high-duty vertical-spindle machines are manufactured that will efficiently finish flat surfaces of castings and drop forgings from the rough.

Chapter 14, *Grinding Principles and Practice*, deals fully with various phases of surface grinding. See pages 456 to 501.

Figure 12-22 shows a rotary surface grinder in which the work is held on a magnetic chuck and revolves while the face of the wheel does the grinding. Many small pieces can be finished in this manner.



**Fig. 12-21.** A heavy-duty hydraulic vertical surface grinder. (*Pratt & Whitney*)

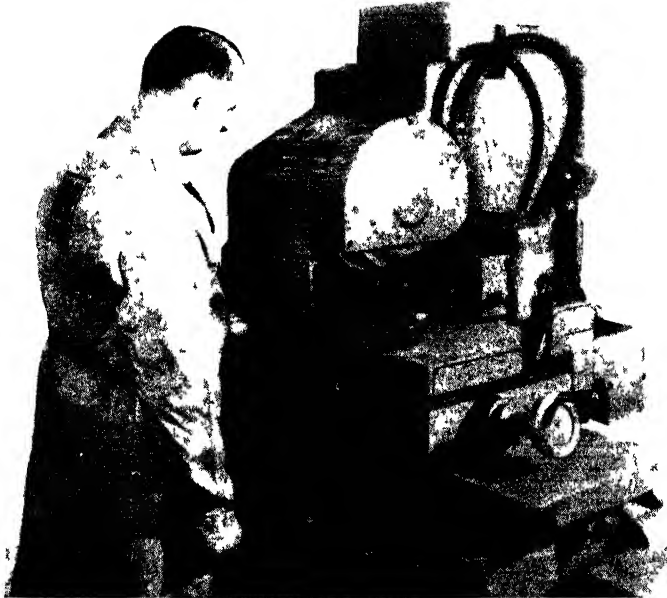


Fig. 12-22. Rotary surface grinder (The Heald Machine Company)

### THE CUTTER AND TOOL GRINDER

This machine is especially designed to sharpen reamers, taps, and all kinds of milling cutters. The machine illustrated in Fig. 12-23 has a fast and a slow reciprocating movement of the table. All the parts are identified and should be easy to learn.

#### **DEFINITIONS: GRINDING TERMS<sup>1</sup>**

**Abrasive.** A substance used for abrading—grinding, polishing, lapping—such as the natural materials, corundum, emery, diamond, etc., and the manufactured or electric furnace materials, aluminum oxide ( $\text{Al}_2\text{O}_3$ ), silicon carbide ( $\text{SiC}$ ) and boron carbide ( $\text{B}_4\text{C}$ ).

**Accuracy.** Conformity in dimension to an exact standard.

**Alumina.** Unfused Aluminum Oxide.

<sup>1</sup> Courtesy of the Norton Company

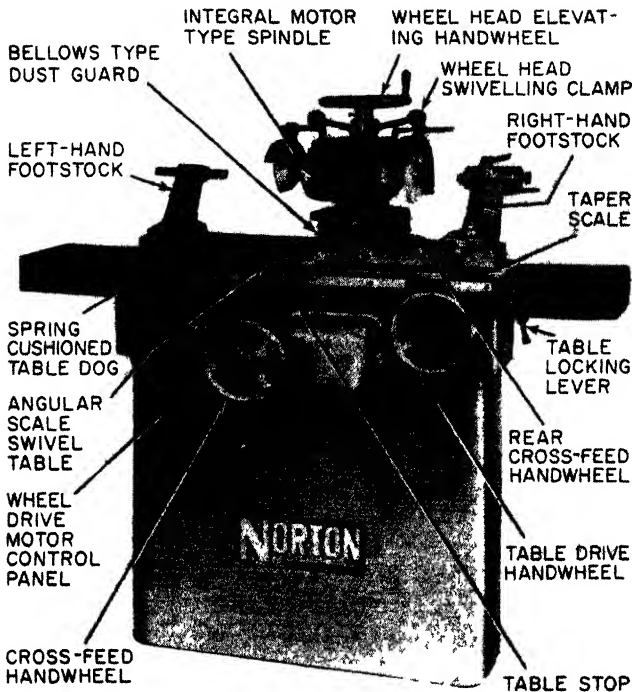


Fig. 12-23. A cutter and tool grinder. (Norton Company)

*Aluminum Oxide.* An abrasive made by fusing the mineral Bauxite ( $Al_2O_3$ ).

*Alundum.* Norton Company's registered trade-mark for fused alumina, an abrasive made by melting the mineral Bauxite in an electric furnace.

*Arbor.* The spindle of the grinding machine on which the wheel is mounted.

*Arbor Hole.* The hole in a grinding wheel sized to fit the machine arbor.

*Arc of Contact.* That portion of the circumference of a grinding wheel touching the work being ground.

*Area of Contact.* The total area of the grinding surface of a grinding wheel in contact with the work being ground.

*Arkansas Oilstones.* A natural stone quarried in the Ozark Mountains and a producer of the finest cutting edges.

*Balance (dynamic).* A piece in static balance is in dynamic balance, if, upon rotating, there is no vibration nor "whip" action due to unequal distribution of its weight throughout its length.

- Balance* (static). A grinding wheel is in static balance when, centered on a frictionless horizontal arbor, it remains at rest in any position.
- Balancing*. Testing for balance, adding or subtracting weight to put a piece into either static or dynamic balance.
- Bauxite*. A mineral ore high in aluminum oxide content, from which Alundum abrasive is manufactured.
- Bearing*. Point of support. The part of a machine in which the spindle revolves.
- Bench Stand*. An off-hand grinding machine, mounting either one or two wheels mounted on a horizontal spindle, attached to a bench.
- Blotter*. A disk of compressible material, usually of blotting paper stock, used between a wheel and flanges when mounting.
- Bond*. The material in a grinding wheel which holds the abrasive grains together.
- Boron Carbide*. The hardest material ever made commercially by man.
- Brick*. A block of bonded abrasive used for such purposes as rubbing down castings, scouring castings, general foundry and machine-shop use, scouring chilled iron rolls, polishing marble, and work of like nature.
- Brinell Hardness Tester*. A machine used for testing the indentation hardness of metals except very hard ones like tool steels.
- Burning* (the work). A change in the work being ground caused by the heat of grinding, usually accompanied by a surface discoloration.
- Burr*. A turned-over edge of metal resulting from punching a sheet and sometimes from grinding or cutting off operations.
- Burring*. Act of removing burrs from metal.
- Burring* (pulpstone). Passing over the face of a pulpstone with a special tool to develop a pattern to provide a freer cutting surface.
- Bushing*. The material, usually lead, babbitt, or aluminum, which sometimes serves as a lining for the hole in a grinding wheel.
- Center-hole Lapping*. The cleaning or lapping of center holes with a bonded abrasive wheel cemented onto a steel spindle.
- Centerless Grinding*. Grinding the outside or inside diameter of a round piece not mounted on centers.
- Centers*. Conical steel pins of a grinding machine upon which the work is centered and rotated during grinding.
- Ceramics*. Science and art of clay working and various related industries. The use of vitrified bonds brings abrasive wheel manufacture under this classification.
- Chatter Marks*. Surface imperfections on the work being ground, usually caused by vibrations between the wheel and the work.
- Chuck*. A device for holding grinding wheels of special shape or the work-piece being ground.

- Coated Abrasives.* Paper or cloth having abrasive grains bonded into the surface.
- Collets.* See *Flanges*.
- Cone Wheel.* A small wheel shaped like a bullet nose, which is used for portable grinding.
- Controlled Structure.* The process of manufacturing grinding wheels, whereby the relationship between the abrasive and the bond is definitely controlled.
- Coolant.* The liquid or solution used to cool the work and to prevent it from rusting.
- Coping.* Sawing stone with a grinding wheel.
- Corner Wear.* The tendency of a grinding wheel to wear on a corner so that it does not grind sharp corners without fillets.
- Corundum.* A natural abrasive of the aluminum oxide type, of higher purity than emery.
- Crank Wheel.* An expression used to designate wheels for grinding crankshafts.
- Critical Speed.* Every spindle with a wheel or point mounted on it has a certain critical speed at which vibration due to deflection or whip tends to become excessive.
- Crush Dressing.* The process of using steel rolls to form or dress grinding wheels to a wide variety of shapes.
- Crystal.* A solid symmetrical particle, bounded by plane surfaces.
- Crystalline.* Made up of crystals.
- Crystallize.* To convert into crystal.
- Cup Wheel.* A grinding wheel shaped like a cup or bowl.
- Cutters.* The part of a grinding-wheel dresser that comes in contact with the wheel and does the cutting.
- Cutting-off Wheel.* A thin wheel, usually made with an organic bond, for cutting off.
- Cutting Rate.* The amount of material removed by a grinding wheel per unit of time.
- Cutting Surface.* The surface or face of the wheel against which the material is ground.
- Cylinder Wheel.* A grinding wheel of similar characteristics to a straight wheel but with large hole size in proportion to its diameter and usually of several inches height.
- Cylindrical Grinding.* Grinding the outside surface of a cylindrical part mounted on centers.
- Diamond Tool.* A diamond dresser.
- Diamond Wheel.* A grinding wheel in which the abrasive is natural bort diamond.



*Disk Grinder.* A machine on which abrasive disks are used for grinding.

*Disk Wheel.* A grinding wheel shaped similar to a straight wheel, but usually mounted on a plate and using the side of the wheel for grinding.

*Discoloration.* See Burning (the work).

*Dish Wheel.* A wheel shaped like a dish.

*Dog.* A device attached to the work piece by means of which the work is revolved.

*Dressers.* Tools used for dressing a grinding wheel.

*Dressing.* A grinding wheel is dressed to improve or alter its cutting action.

*Ductile.* Capable of being readily pressed or drawn or otherwise formed into various shapes.

*Emery.* A natural abrasive of the aluminum oxide type.

*External Grinding.* Grinding on the outside surface of an object as distinguished from internal grinding.

*Face.* That part of a straight wheel on which cylindrical and surface grinding is usually done.

*Feed, Cross.* Surface grinding. The distance of horizontal feed of the wheel across the table.

*Feed, Down.* Surface grinding. The rate at which the abrasive wheel is fed into the work.

*Feed, Index.* Cylindrical grinding. Measurement indicated by the index of the machine. On most machines this measurement refers to the diameter of the work; on a few, to the radius.

*Feed Lines.* A pattern on the work produced by grinding. The finer the finish, the finer and more evident are these lines. Some types of feed lines indicate incorrect grinding condition.

*Fin.* A thin projection on a casting.

*Finish.* The surface quality or appearance, such as that produced by grinding or other machining operation.

*Finishing.* The final cuts taken with a grinding wheel to obtain accuracy and the surface desired.

*Flanges.* The circular metal plates on a grinding machine used to drive the grinding wheel (see *Wheel Sleeves*).

*Flaring Cup.* A cup wheel with the rim extending from the back at an angle so that the diameter at the outer edge is greater than at the back.

*Floor-stand Grinders.* An offhand grinder, mounting either one or two wheels running on a horizontal spindle fixed to a metal base attached to the floor.

*Fluting.* Grinding the grooves of a twist drill or tap.

*Freehand Grinding.* Grinding by holding the work against the wheel by hand, usually called *offhand* grinding.

- Gate.* The part of a casting formed by the opening in the mold through which the metal is poured.
- Generated Heat.* Heat resulting from the removal of metal by a grinding wheel.
- Glazing.* The dulling of the cutting particles of a grinding wheel resulting in a decreased rate of cutting.
- Grade.* The strength of bonding of a grinding wheel, frequently referred to as its hardness.
- Grain.* Abrasive classified into predetermined sizes for use in polishing, in grinding wheels and in coated abrasive.
- Grain Size.* The size of the cutting particles of a grinding wheel or polishing abrasive.
- Grain Spacing.* The relative position of the cutting particles in a grinding wheel.
- Grinding.* Removing material with a grinding wheel.
- Grinding Action.* Refers to the cutting ability of, and the finish produced by, a grinding wheel.
- Grinding Machines.* Any machine on which a grinding wheel is operated.
- Grinding Wheel.* A cutting tool of circular shape made of abrasive grains bonded together.
- Grindstone.* A flat, circular grinding wheel cut from natural sandstone sometimes used for sharpening tools.
- Hand Grinding.* See *Offhand Grinding*.
- Hemming Machines.* Machines used for grinding flat surfaces such as cutlery blades and skates—named after the inventor Mr. C. H. Hemming.
- Honing.* An abrasive operation typically performed on internal cylindrical surfaces and employing bonded abrasive sticks in a special holder to remove stock and obtain surface accuracy.
- Hoods.* Metal guards used for protection against wheel breakage.
- Huntington Dresser.* A tool using star-shaped cutters for truing and dressing grinding wheels, invented by a man named Huntington.
- Inserted Nut.* Disk, segment, or cylinder wheels having nuts embedded in the back surface for mounting on the machine.
- Internal Grinding.* Grinding the inside surface of the hole in a piece of work.
- Lapping.* A finishing process typically employing loose abrasive grain, but now often including similar types of operation with bonded abrasive wheels or coated abrasives.
- Loading.* Filling of the pores of the grinding-wheel surface with the material being ground, usually resulting in a decrease in production and poor finish.

- Lubricant.* The liquid or solution used to lubricate the wheel and promote a more efficient cutting action.
- Mounted Points and Wheels.* Small, bonded abrasive shapes and wheels that are mounted on steel spindles.
- Mounting.* Putting a grinding wheel on the arbor or spindle of the machine.
- Natural Abrasive.* A hard mineral found in nature (see *Abrasive*).
- Off-grade.* Bonded abrasive materials which are not of exact grade.
- Offhand Grinding.* Where the work is held in the operator's hand, otherwise known as *freehand grinding*.
- Oilstone.* A natural or manufactured abrasive stone impregnated with oil and used for sharpening keen-edged tools.
- Operating Speed.* The speed of revolution of a grinding wheel expressed in either revolutions per minute or surface feet per minute.
- Organic Bond.* A bond made of organic materials such as the synthetic resins, rubber, or shellac.
- Peripheral Speed.* The speed at which any point or particle on the face of the wheel is traveling when the wheel is revolved, expressed in surface feet per minute (s.f.p.m). Multiply the circumference in feet by the wheel revolutions per minute.
- Periphery.* The line bounding a rounded surface—the circumference of a wheel.
- Planer Type.* A type of surface-grinding machine built similar to an open side planer.
- Plate Mounted.* Disk, segment, or cylinder wheels cemented to a steel back plate having projecting studs or other means for mounting on the machine.
- Polishing.* Act of smoothing off the roughness or putting a high finish on metal by applying to a polishing wheel or belt.
- Polishing Wheel.* A wheel, which can be made of several different kinds of materials, that has been coated with abrasive grain and glue.
- Portable Grinder.* One that is used manually and can be easily transported.
- Precision Work.* Work that is required to be exact in measurements, finish, etc. Work that must be ground with great care.
- Production.* The quantity of product turned out or the amount of work done in a given time or during the life of a grinding wheel.
- Profilometer.* An instrument for measuring the degree of surface roughness in micro inches.
- Protection Flanges.* See *Safety Flange*.
- Protection Hoods.* See *Hoods*.
- Puddled Wheel.* Wheel made by a process wherein the mixture is of such a consistency that it can be poured into molds.
- Recessed Wheels.* Grinding wheels made with a depression in one side or

both sides to fit special types of flanges or sleeves, provided with certain grinding machines.

*Resinoid Bond.* A bonding material described commercially as synthetic resin.

*Rest.* That part of a grinding-wheel stand which is used to support the work, dresser, or truing tool when applied to the grinding wheel.

*Rockwell Hardness Tester.* A machine used for testing the indentation hardness of all metals.

*Roll-grinding Machine.* A machine for grinding cylindrical rolls used for rolling metal, paper, or rubber.

*Rough Grinding.* The first grinding operation for reducing stock rapidly without regard to the finish the wheel leaves.

*R.P.M.* Revolutions per minute.

*Rubber Bond.* A bonding material the principal constituent of which is natural rubber or synthetic rubber.

*Rubber Wheels.* Wheels made with rubber bond.

*Safety Devices.* Devices for the protection of operators and machines in case of accident.

*Safety Flanges.* Special types of flanges designed to hold together the broken parts of a wheel in case of breakage, thus protecting workmen.

*Saucer Wheel.* A shallow, saucerlike wheel.

*Saw Gummer.* A grinding wheel used for gumming saws.

*Saw Gumming.* Saw sharpening and sharpening with a grinding wheel.

*Scale.* A black, scaly coating on the surface of heated steel and upon other metals—as in forging and rolling.

*Scleroscope.* An instrument for determining the relative hardness of materials by a drop-and-rebound method.

*Scratches.* Marks left on a ground surface caused by a dirty coolant or a grinding wheel unsuited for the operation.

*Segments.* Bonded abrasive sections of various shapes to be assembled to form a continuous or intermittent grinding surface.

*S.F.P.M.* Surface feet per minute. See *Peripheral Speed*. Multiply the circumference in feet by the wheel revolutions per minute.

*Sharpening Stone.* A natural or manufactured abrasive stone, usually of oblong shape, used for sharpening or whetting tools.

*Shellac Bond.* A bonding material the principal constituent of which is shellac.

*Silica.* Silica Oxide ( $\text{SiO}_2$ ).

*Silicate Bond.* Type of bond matured by baking, in which silicate of soda is an important bonding constituent.

*Silicon Carbide.* An abrasive made from coke and silica sand—Norton Crystolon ( $\text{SiC}$ ).

*Snagging.* Grinding the gates, fins, and sprues from castings.

*Spindle.* See *Arbor*.

*Stand.* See *Bench* and *Floor Stand*.

*Steady-rest.* A support for pieces being ground on a cylindrical grinding machine.

*Straight Wheel.* A grinding wheel of any dimension which has straight sides, a straight face, and a straight or tapered arbor hole, and is not recessed, grooved, dovetailed, beveled, or otherwise changed from a plain straight wheel.

*Structure.* A general term referring to the proportion and arrangement of abrasive and bond in an abrasive product.

*Structure Number.* A term designating the relative grain spacing in an abrasive product. Dense relative spacing corresponds to low numbers such as 0, 1, 2, etc.; open spacing to higher numbers—10, 11, 12 (see page 418).

*Stub.* That portion of a grinding wheel left after having been worn down to the discarding diameter for a particular operation or machine.

*Surface Grinding.* Grinding a plane surface.

*Surface-grinding Machine.* A machine for grinding plane surfaces.

*Swing-frame Grinder.* A grinding machine suspended by a chain at the center point so that it may be turned and swung in any direction for the grinding of billets, large castings, or other heavy work.

*Table.* That part of the grinding machine which directly or indirectly supports the work being ground.

*Table Traverse.* Reciprocating movement of the table of a grinding machine.

*Tapered Wheel.* A grinding wheel shaped similar to a straight wheel but having a taper from the hub of the wheel to the face and thus being thicker at the hub than at the face.

*Temper.* The heat-treatment of a material to develop required qualities.

*Tensile Strength.* The strength of a material when tested in tension, usually given in pounds per square inch.

*Treatment.* A material impregnating an abrasive product aiming to improve its grinding action, often by reducing the tendency for loading in use.

*Truing.* A grinding wheel is trued in order to restore its cutting face to running truth, so that it will produce perfectly round (or flat) and smooth work; or to alter the cutting face for grinding special contours.

*Tumbling.* An operation for deburring, breaking sharp edges, finishing, and polishing in which abrasive, water, and the work are "tumbled" in a rotating barrel or by other means.

*Universal Grinding Machine.* A machine on which cylindrical, internal and surface grinding can be done—usually used for tool-room work.

*Vitrified Bond.* A bonding material of which the chief constituent is clay.

*Washita Oilstones.* A natural stone preferred by many to produce smooth, long-lasting edges.

*Wheel Sleeves.* A form of flange used on precision grinding machines where the wheel hole is larger than the machine arbor. Usually, the sleeve is so designed that wheel and sleeve are assembled as one unit.

*Wheel Speed.* The speed at which a grinding wheel is revolving, measured either in revolutions or in surface feet per minute.

*Wheel Traverse.* The rate of movement of the wheel across the work.

*Work.* Used to designate the material being ground in a machine.

*Work Speed.* In cylindrical, centerless, and internal grinding, the rate at which the work revolves, measured in either r.p.m. or s.f.p.m.; in surface grinding, the rate of table traverse measured in feet per minute.

## QUESTIONS ON GRINDING - MACHINE CONSTRUCTION

1. What is the function of a grinding machine?
2. Compare what you just wrote with the function of any other machine tool. Are they the same? different?
3. What is the name of the cutting tool used in grinders?
4. How accurate can grinders produce work?
5. What kind of finishes are usually produced by precision grinders?
6. Name at least four types of grinders.
7. State the kinds of work done by these different types.
8. What is meant by a "universal" grinder? How does it differ from a plain grinder?
9. Name three important parts of a universal grinder and give a brief description of them. State their functions, as well.
10. What is meant by the face of a grinding wheel?
11. What is an arbor? a mandrel? What is the main difference between them?
12. Why is it possible to do more work in a machine having an automatic feed?
13. Why does automatic feed make for better work?
14. What is the reason for the spring in the footstock of a universal grinder?
15. Why is the headstock made so that it can be swiveled?
16. How is the footstock aligned with the headstock? When must they be in perfect alignment?
17. State at least three reasons why the grinding machine is an indispensable tool in a machine shop.

## Grinding Wheels<sup>1</sup>

Success in grinding depends more upon the knowledge the operator has of the characteristics (and particularly the action under different conditions) of the grinding wheel than upon anything else. It is an interesting study, and the more deeply one gets into it the more interesting it becomes. Grinding offers to the young machinist one of the most fascinating and worth-while studies in the whole field of machine work.

Take any grinding wheel and examine it, preferably with a magnifying glass if one is at hand. It will be observed that the wheel is made up of a great many particles of abrasive bonded together. There are various materials used to hold the crystals of abrasive together. They are called *bonds*. Some wheels are much coarser than others; the size of the particles of abrasive determines the coarseness or fineness of the wheel, as, similarly, the size of the teeth determine the coarseness or fineness of a file.

It will be observed further that the particles of abrasive have sharp projecting edges and points (crystalline fracture). These are the cutting edges, and the abrasive is hard enough to cut hardened steel and tough enough to stand up without fracturing under the cutting pressure. The action of the abrasive or grinding wheel, mounted on the spindle of the grinding machine, and revolving at a high rate of speed, is to bring a countless number of cutting points and edges into contact with the metal to be removed. An abrasive wheel is a *cutting tool*.

The little cutting points and edges become dull after a time and to "keep the wheel sharp" it is necessary for the dull particles to be

<sup>1</sup> All illustrations in this chapter provided by The Carborundum Company.

removed so as to allow the sharp particles underneath to appear and do the cutting. The ideal wheel would have a bond just strong enough to permit the wheel automatically to sharpen itself; that is, when the cutting edges were too dull to do good work on the given material, the excessive pressure of the cut would serve to break away the dull particles. The different grinding jobs offer variable conditions of cutting pressure, etc., and consequently the particles of abrasive are more firmly held together in some wheels than in others. The wheel which retains its particles with the greatest tenacity is called *hard*, and the wheel from which the particles are easily removed is called *soft*. (Remember the particles are no softer in a soft wheel, but the *bond* is less strong, which makes the *wheel* softer.)

The tendency of most machinists is to use a wheel that is too hard. "Use a soft wheel" is almost as important a slogan in grinding as "keep cutters sharp" is in milling. To be sure, a soft wheel does wear away more rapidly, but is it not wiser to wear out a \$3 wheel earning \$100 than to save part of the wheel and earn only \$50 in the same length of time?

Before proceeding to a discussion of their selection and use, brief descriptions of the distinguishing features and characteristics of grinding wheels are offered. The following pages will give an idea of what grinding wheels are, of the differences in materials and methods that obtain in making wheels for various purposes, and of the care that must go into the making.

**Abrasive Tools of the Machine Shop.** The abrasive tools in general use in machine-shop practice may be classified into four groups: (1) *grinding wheels*, (2) *coated abrasive products*, (3) *polishing grains*, and (4) *sharpening stones* and *abrasive sticks*.

*Grinding wheels* are basically composed of a combination of abrasive grains and a bonding material, or "binder."

*Coated abrasive products* are manufactured by applying abrasive grains to an adhesive-coated backing of fiber or to an adhesive-coated backing of paper or cloth, or a combination of both.

*Polishing grains* are produced in a wide variety of grain sizes and are used with glue on setup polishing wheels. Other grain sizes are also mixed with certain carriers for the making of lapping compounds.



*Sharpening stones* and *Abrasive sticks* are a composition of abrasive grains and certain bonding materials molded into shapes for sharpening edged tools and other specific industrial uses.

### COMPONENT ELEMENTS OF A GRINDING WHEEL

As grinding wheels are of the most importance to industrial production and the most widely used of all abrasive tools, they will be discussed first. Other abrasive tools will be discussed later.

The basic component elements built into a grinding wheel are: (1) *abrasive grain*—an element which does the job of cutting; (2) *bonding material*—an element which acts as a “binder” and holds the abrasive grains in the form of a wheel; (3) *grade*—a measure of the strength with which the bonding material holds abrasive grain particles in the form of a wheel, and also a measure of the resistance offered by the composite strength of bonding material and grain particles to the grinding stresses which operate to tear the grain particles out of the wheel face and wear away the wheel; and (4) *structure*—as all grinding wheels are porous to some degree, depending on the size of built-in pore spaces, structure is basically the relationship of abrasive grain to bonding material and the relationship of these two elements to the spaces or voids that separate them.

**Abrasive Grain.** An abrasive is an extremely hard material and, more or less, a tough substance which, when fractured, has the formation of many sharp cutting edges and corners. An abrasive is composed of small particles known as *grains*. There are two types of abrasive grains, the *natural* and the *manufactured*.

Natural abrasives, such as emery, sandstone, corundum, and quartz, which are mined, are referred to as *natural* abrasives because they were produced by the *uncontrolled* forces of nature. Because of this lack of control and consequent presence of impurities, the use of natural abrasives has been largely discontinued. For example, emery might contain 65 per cent of abrasive or cutting material and 35 per cent of impurities. These impurities not only hinder the cutting action but tend to create nonuniformity in abrasive wheels manufactured from this natural abrasive.

Manufactured abrasives, such as fused aluminum oxide and silicon carbide, are products of the electric furnace. The methods

by which they are produced are *controlled*. Therefore, the quality and characteristics of these two abrasive types can be changed to meet specific grinding conditions. There is no guesswork as to the composition of any wheel manufactured in which these two types of abrasives are used.

*Aluminum Oxide.* This abrasive is a tough, sharp grain whose chemical formula is  $Al_2O_3$ . It is produced in an arc-type electric furnace by charging bauxite, a clay, which contains the purest form of aluminum oxide found in commercial quantities, with given percentages of ground coke and iron borings. In the huge arc furnace the chemically combined water is driven off, impurities in the ore are reduced to their metals, combine with the iron, and collect at the bottom, and heavy masses ("pigs") of crystalline aluminum oxide, one of the hardest materials known, are formed. The pigs are crushed, the impurities separated, and the grains screened in standard sizes.

Crystals of aluminum oxide are very hard and sharp, and, in addition, the "temper," that is, the combination of hardness, toughness, and fracture, can be controlled in manufacture to suit the conditions for which the abrasive is to be used. They are not so hard as crystals of silicon carbide, but are less brittle and will stand up better when they are used for grinding materials of high tensile strength, such as carbon and alloy steels—soft or hard—malleable and wrought iron, tough bronzes, etc.

Trade names applied to aluminum oxide by some of the grinding-wheel manufacturers follow:

Manufacturer	Trade Name
The Carborundum Company	Aloxite
The Norton Company	Alundum
Macklin Company	Aluminum oxide
Abrasive Company	Borolon

Another special form of aluminum oxide is white in color. It has a tendency to fracture more readily than regular aluminum oxide, and thus more new and sharper cutting edges are presented to the work. It is the abrasive to select for grinding hardened tool steel or for use in general toolroom grinding.

*Silicon Carbide.* This is a very hard, sharp abrasive grain, the chemical formula of which is  $SiC$ . It is the abrasive to use in the

grinding or cutting of low-tensile-strength materials, such as cast iron, bronze, aluminum, copper, and nonmetallic materials. Silicon carbide is the crystalline formation of two elements, silicon and carbon, accomplished by subjecting a mass of silica sand and coke (with relatively small amounts of sawdust and salt for certain chemical reactions) to a heat of about 4,000 deg. F. for 30 hr. or more in a resistance-type electric furnace. The modern furnace is about 6 or 8 ft. wide and high, and about 40 ft. long. The crystals formed by this process, tons at a time, are extremely hard and sharp, but quite brittle. When cooled, the masses of beautifully colored crystals are crushed and recrushed under great rolls, cleaned of all impurities, and screened for various sizes.

Owing to the extreme brittleness of crystals of silicon carbide, the grinding wheels made of this abrasive are not best adapted to grinding materials of high tensile strength, such as steel, but are recommended for materials of lower tensile strength, such as cast iron, brass, bronze, aluminum, and copper, also nonmetallic substances such as rubber, celluloid, marble, and glass.

Trade names applied to silicon carbide by some of the grinding-wheel manufacturers follow:

<b>Manufacturer</b>	<b>Trade Name</b>
The Carborundum Company	Carborundum
The Norton Company	Crystolon
Macklin Company	Silicon carbide
Abrasive Company	Electrolon

Another special form of silicon carbide, which is green in color, is used to grind or resharpen cemented carbide-tipped tools. This form has been called *Green-grit Carborundum* by the Carborundum Company.

*Grain Size.* After the abrasive material is crushed and cleaned of the dirt and other impurities, it is sorted for the purpose of determining grain size. The smaller particles are separated by being sifted through screens of various sizes. Particles of abrasives of these sizes are called *grits* or *grains*. The sizes of such grains are named according to the size of the screen openings through which they are sorted or sifted, and the grit sizes thus established are standard throughout the abrasive industry.

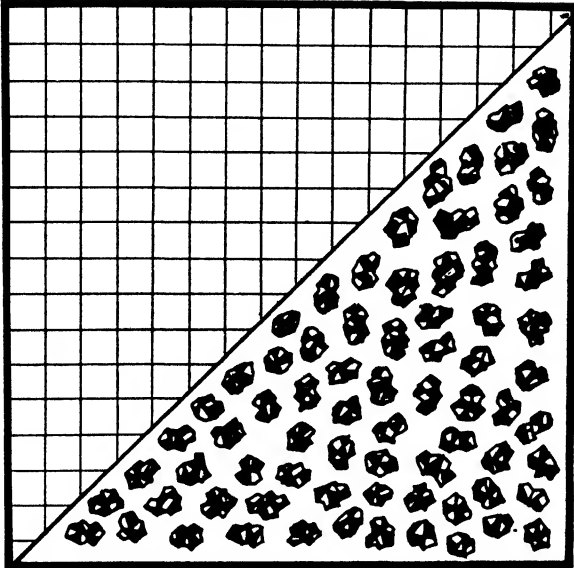


Fig. 13-1. Grain size: 8.

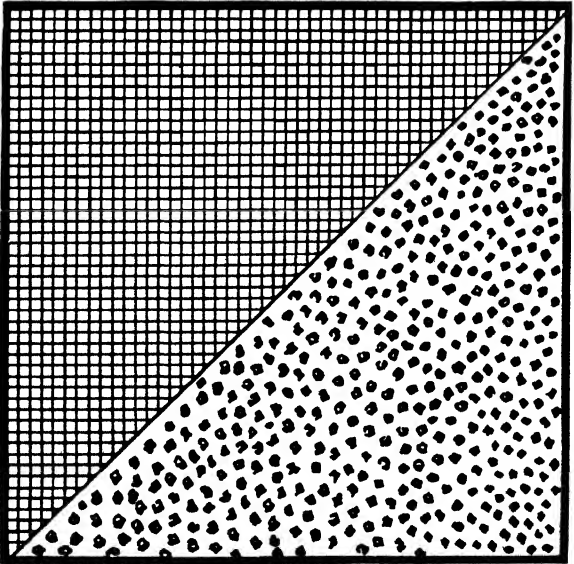


Fig. 13-2. Grain size: 24.

For example, a grain or grit which goes through a screen 8 meshes or openings per linear inch is called *8-grain size*, or *8-grit size* (Fig. 13-1). A 24-grain size (Fig. 13-2) is approximately  $\frac{1}{24}$  of an inch across, just as an 8-grain size is roughly  $\frac{1}{8}$  of an inch across. Figure 13-3 shows a grain size of 60.

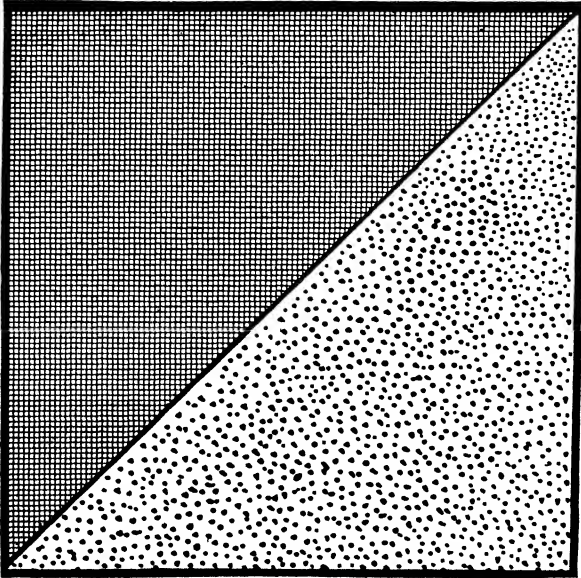


Fig. 13-3. Grain size: 60.

The commercial grain sizes are as follows: *coarse range*: 6 to 24; *medium range*: 30 to 100; *fine range*: 120 to 600, 280 being labeled as *F*, 320 as *FF*, and 500 as *FFF*.

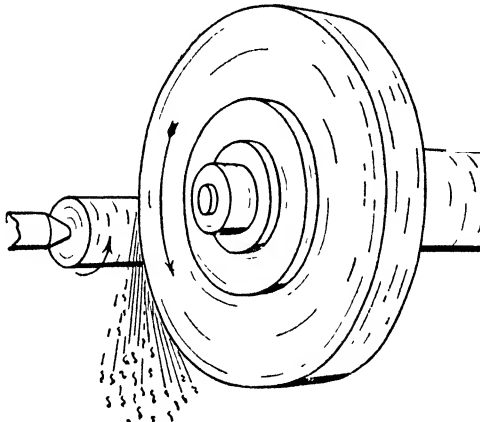
*Function of Abrasive Grains.* Grinding wheels are essentially disks of various thicknesses containing thousands of abrasive grain particles, each one of which is actually a sharp cutting tool. They do the job of cutting away the surface of the material being ground.

The abrasive grain actually cuts away small pieces of the work (Fig. 13-4). These small pieces are commonly referred to as *chips*, and their presence is evidence that the modern grinding wheel cuts in a way similar to that of a multipoint cutting tool.

The size of the chip is subject to control by the introduction into the wheel, at the time of manufacture, of one of the many available grit sizes. These grit sizes range from very coarse to very fine ones.

Generally speaking, coarse grit sizes will cut away bigger chips and, as a result, leave a rougher surface on the work being ground. Fine grit sizes cut away smaller chips and thus leave a smoother surface.

To illustrate the method by which the abrasive-grain particles in a grinding wheel actually cut chips out of the work being ground,



**Fig. 13-4.** Chips from a grinding wheel.

the illustration in Fig. 13-5 is offered. Here the abrasive grain cuts into the work until it becomes dull, then it breaks down (fractures), exposing new cutting edges, with the sharp edges toward the work.

However, it is evident that the breakdown or fracturing procedure of individual grain particles comes to an end when each abrasive grain has been worn out and can no longer function as a cutting tool. Theoretically, when this point is reached, grain particles are pulled out or forced out of the grinding-wheel face by pressures generated in the grinding operation. As this happens, new, sharp abrasive grains are immediately exposed, to continue the cutting or grinding operation.

Under the conditions described above, the question arises as to what holds the abrasive grain or grit in place within the wheel face

and releases it when it is no longer capable of cutting efficiently. This job is done by what is called the *bond*.

**Bonds.** Bond is the material in a grinding wheel that holds the abrasive grain particles in the form of a wheel. The bond may be compared to a tool post holding the grain—the cutting tool—in place while it does its work.

When individual grain particles become dull or break down completely, the bond material releases the dull abrasive grain and thus exposes new, sharp abrasive grain particles to continue the work.

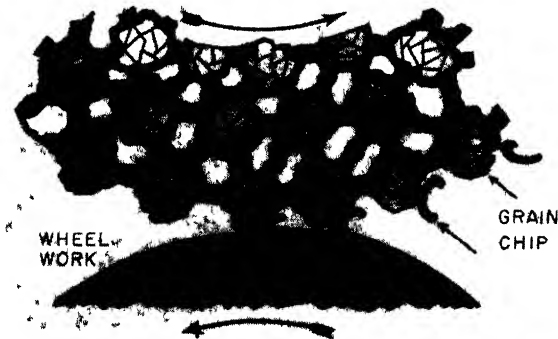


Fig. 13-5. Illustration indicating how voids in the structure of a grinding wheel assist in clearing chips from the wheel face and thus eliminate "loading"

Five principal bond types used in the manufacture of grinding wheels are:

**Vitrified Bond.** For more than 75 per cent of the grinding wheels manufactured vitrified bond is used. Porosity and strength, characteristic of wheels made of this bond, give high stock removal. This bond is not affected by water, acid, oil, or ordinary temperature conditions.

**Silicate Bond.** Wheels of silicate bond, which release the abrasive grains more readily than vitrified-bond wheels do, are used for grinding edged tools and under conditions in which heat generated in grinding must be kept at a minimum.

**Shellac Bond.** This bond is capable of producing high finishes on

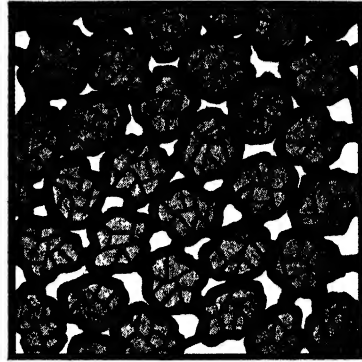
camshafts, mill rolls, etc. It is cool-cutting on hardened tool steels and thin sections.

**Resinoid Bond.** This is a synthetic organic compound, and resinoid-bonded wheels can be made in various structures—from hard, dense, coarse wheels to soft, open, fine wheels. They cut cool, remove stock rapidly, and can be run at high speeds.

**Rubber Bond.** Where a good finish is required, rubber bond is chiefly used. Because of its strength and toughness, this bond is extensively put to use in the making of extremely thin wheels.

**Grade.** The grade of a grinding wheel is generally considered to be the measure of “holding power,” or the degree of strength with which the bond holds the abrasive grains in place within the wheel. It is also the measure of the resistance offered by the composite strength of the bond and the abrasive grains to the grinding stresses which operate to tear the grain particles out of the wheel face, break down the bond, and thus wear away the wheel.

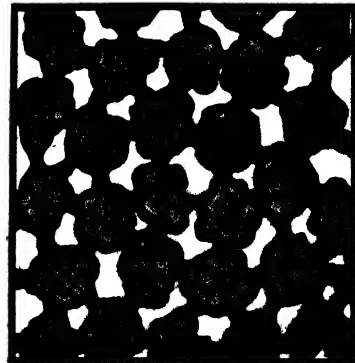
Depending upon the type of bond, it is the amount of bond material which determines the degree of “hardness” or “softness” of a grinding wheel. Wheels from which the abrasive is more readily



a. Dense



b. Medium



c. Open

Fig. 13-6. Spacing in grinding wheels.→



broken away are known as of *soft* grade, and those that strongly retain the particles are called *hard* wheels or grade.

**Structure** (Fig. 13-6). In an abrasive wheel this term refers to the grain spacing, that is, the density. The kind of bond used has, of course, its effect upon the structure of the wheel; but also, varying densities of wheels having the same abrasive and the same bond are made, and the degree of density is exactly controlled in manufacture. For example, if amounts of abrasive and bond mixture—say, 17 oz. and 16 oz., respectively, for two wheels—are compressed into the same volume, the heavier wheel will have the closer structure.

It has been found in many cases that wheels of a certain density, say, of an open structure, will cut a given material more freely and faster, and will last longer, than a wheel of the same grade and grain but of a closer structure. The manufacturers are able to recommend the structure, as well as the grade and grain, most likely to be best suited for the job, and, of course, the intelligent machinist or job foreman must be able to check these recommendations.

### STANDARD GRINDING-WHEEL SHAPES

The United States Department of Commerce and the Grinding Wheel Manufacturers Association, in cooperation with the principal manufacturers of grinding machines, have established nine standard grinding-wheel shapes and have also standardized the dimensional sizes in which these wheels may be obtained. This is the group of wheels used most frequently in industrial grinding operations.

Each standard grinding-wheel shape has its own type number, which is the means of identifying it. Each shape may be obtained in identical shape and dimensions from any wheel manufacturer. Therefore, the grinding-wheel operator has a simple task in applying any one of the standard grinding-wheel shapes to his grinding job, regardless of the source of manufacture.

A great number of *special* grinding-wheel shapes are used in less frequent or highly specialized grinding operations. But, for the time being, this discussion is generally confined to illustrations and analysis of the sizes and basic uses of the nine standard grinding-wheel shapes. This limitation is made here because the grinding-

machine operator will find that his use of grinding wheels is largely restricted to these nine wheel shapes.

For standard dimensions of these wheel shapes, consult the catalogue of the manufacturer from whom you intend to buy the wheels.

**Wheel Types.** *Straight Wheel Types.* Figures 13-7, 13-8, and 13-9 are examples of the straight wheel type of grinding wheels. Figure 13-7 is known as the *straight* type, with no recesses. Fig. 13-8 is recessed on one side only; and Fig. 13-9 has both sides recessed.

Wheel types Nos. 1, 5, and 7 are standard for internal, cylindrical grinding, tool grinding, off-hand grinding, and snagging. The recesses in types Nos. 5 and 7 give clearance for the mounting flanges.

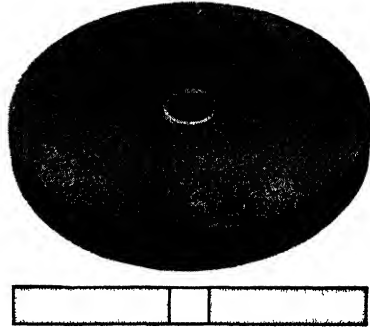


Fig. 13-7. Type No. 1, straight

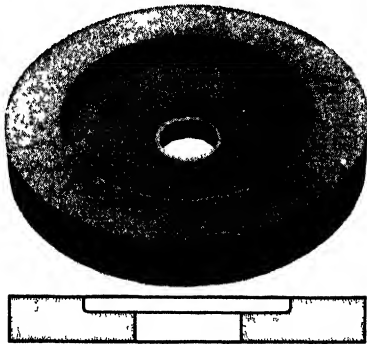


Fig. 13-8. Type No. 5, straight but recessed on one side.

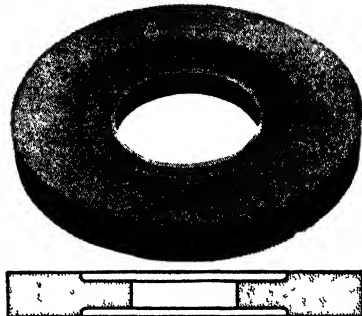


Fig. 13-9. Type No. 7, straight but recessed on both sides

Type No. 1 cutting-off wheels are used for cutting off and slotting and are seldom more than  $\frac{1}{8}$  in. thick, ranging down to as thin as 0.006 in., depending upon the diameter of the wheel.

*Cylinder Wheel Type* (see Fig. 13-10). This wheel is type No. 2 and is used for surface grinding on both horizontal and vertical spindle

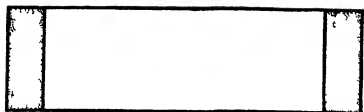


Fig. 13-10. Type No. 2, cylindrical

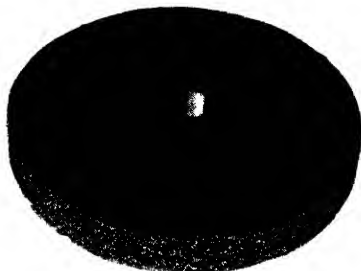


Fig. 13-11. Type No. 4, tapered on both sides



Fig. 13-12. Type No. 6, straight cup

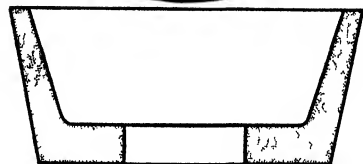
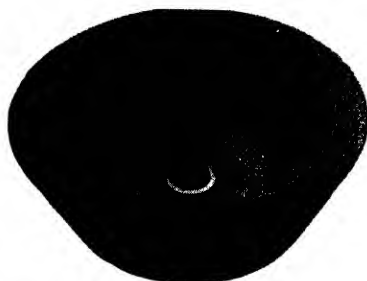


Fig. 13-13. Type No. 11, flaring cup.

machines, with the grinding performed on the face or wall of the wheel.

*Tapered Wheel Type* (See Fig. 13-11). This wheel, known as type No. 4, is a modification of type No. 1, having a taper on both sides, and is used principally for snagging operations. Tapered wheels with tapered mounting flanges are a safety device to prevent pieces

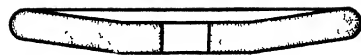
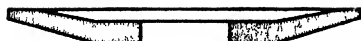
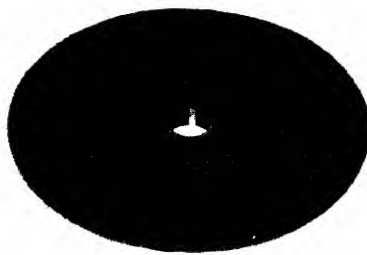
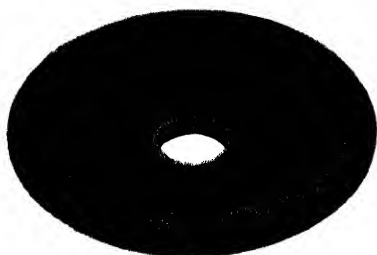


Fig. 13-14. Type No. 12, dish.

Fig. 13-15. Type No. 13, saucer.

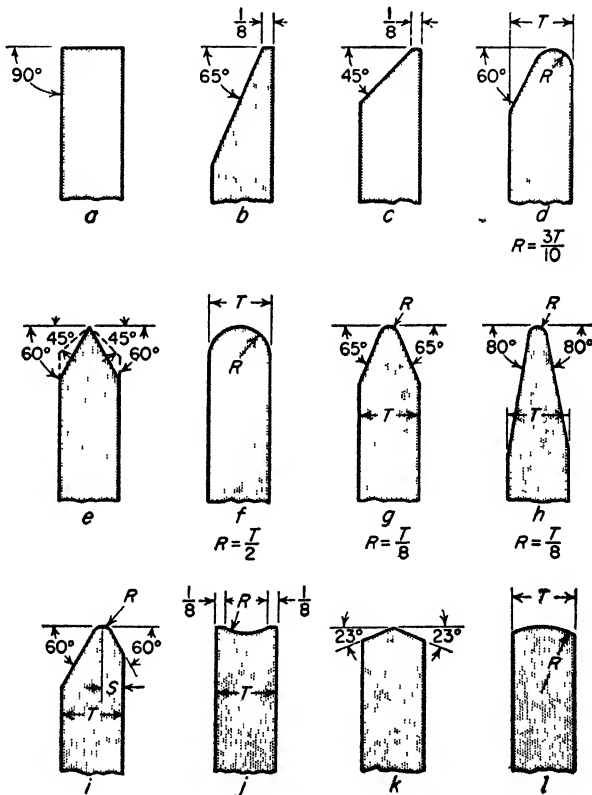


Fig. 13-16. Standard shapes of grinding-wheel faces.



Fig. 13-17. Mounted wheels.

of the wheel from flying out if the wheel should become broken in operation.

*Straight-cup Wheel Type* (see Fig. 13-12). Known as type No. 6, this wheel is used primarily for surface grinding on horizontal- or vertical-spindle machines. It is also useful for off-hand grinding when a flat surface on the work being ground is desired. It is available in either plain or bevel face.

*Flaring-cup Wheel Type* (see Fig. 13-13). This wheel, known as type No. 11, is used for grinding in the toolroom and in resinoid bond for snagging.

*Dish Wheel Type* (see Fig. 13-14). This wheel is known as type No. 12 and is used for toolroom grinding. Its thinness permits the insertion of the grinding edge of the wheel into narrow places.

*Saucer-type Wheel* (see Fig. 13-15). Wheels of this type, known as type No. 13, are used primarily for the resharpener of circular or band saws.

**Standard Grinding-wheel Faces.** For work requiring contour wheels, straight types can be obtained with any of the standard wheel faces shown in Fig. 13-16.

**Mounted Wheels** (see Fig. 13-17). These are small grinding wheels of different shapes and sizes that permit their being used in hard-to-reach places and for internal grinding operations. Mounted wheels are mounted on steel shafts or mandrels which can be inserted into the chuck of a drill press, flexible shaft, lathe tool-post grinder, or hand grinder.

Mounted wheels have many uses in the field of grinding, lending themselves particularly well to the grinding of small holes, difficult corners, and very small areas.

### OPERATIONS IN MAKING THE WHEEL

These operations may be listed in order as follows: truing, bushing, checking the grade, balancing, speed testing, and inspecting.

**Truing.** From the kilns the wheels go to the truing lathes, where they are very rapidly trued to shape and dimensions. Special wheels—say, for grinding crankshafts—are accurate in thickness to within two or three thousandths of an inch. The diameters are turned after bushing.

**Bushing the Wheel.** The arbor holes of most grinding wheels are bushed with lead or Babbitt. Care is taken to have the hole true, and to trim the bush flush with the sides.

**Checking the Grade.** This is commonly done by hand, by slightly twisting a short screw-driverlike tool into the side of the wheel. The resistance offered, compared with the resistance of the bond in a wheel of known grade, indicates the grade.

**Balancing.** Any rapidly revolving element in a machine should be "balanced"; that is, no half of its weight about its axis should be heavier than the opposite half. Machine parts, such as pulleys, fly-wheels, driving wheels, etc., must often be balanced, even after turning. Balancing is accomplished by adding weight to the light side or taking weight from the heavy side.

A revolving part out of balance absorbs more power, causes greater wear in the bearings, sets up undue vibrations and, in the larger pieces especially, is more likely to break. It will be readily understood then how important it is that grinding wheels shall be in practically perfect balance.

Wheels over 12 in. in diameter are tested for balance. If one is found out of balance, the amount is noted in ounces, a cavity is made near the hole on the light side and filled with enough lead to balance. In the larger sizes, as the wheel wears, an out-of-balance condition may develop that will defeat good work and may prove a positive danger. Therefore the larger wheels should be tested occasionally and, if necessary, corrected.

In grinding machines that use large wheels provision is often made for balancing by having a suitable weight, on one of the wheel flanges, that may be shifted as desired. Also, certain wheelmakers provide a lead bushing, a part of which may be removed in order to balance the wheel.

**Speed Testing.** Wheels 6 in. in diameter and larger are given a speed test. They are run, under a hood, at a rate of at least one and a half times the recommended speed. This gives a stress of more than double that which is given in actual practice.

### CUT-OFF WHEELS

Special attention must be given to cut-off wheels because of their increased use in industry. Not very long ago, the abrasive cut-off wheel, either shellac- or rubber-bonded, was used only when the material was of such a character or hardness that it could not be cut with a steel saw. Today, the abrasive-wheel method for cutting off is used for practically all kinds of materials, including steel, brass, and aluminum bars and tubes of all shapes and hardnesses, ceramics, plastics, insulating materials, glass, and cemented carbides. From

hardly more than a toolroom or stock-room application, the abrasive wheel method of cutting off, or parting, has developed rapidly into a high-speed production operation.

**Developments in Abrasive Cut-off Wheels.** The introduction of a third type of abrasive cut-off wheel, made with a resinoid bond and capable of cutting faster and giving more cuts per wheel than the shellac- or rubber-bonded wheel, has opened up new fields for the abrasive cutting-off method. Simultaneously, the abrasive cut-off machines were developed, to permit the resinoid wheels to be operated at their highest efficiency and economy. Some of the developments that have been responsible for the rapid progress in the field of abrasive cutting off are wheel speeds up to 16,000 surface feet per minute (s.f.p.m.) for dry cutting, rigid machine construction, automatic features, and development of machines for wet cutting.

*Why Faster Cutting?* Why should the abrasive wheel be so much faster in cutting? The answer lies in its vastly greater number of cutting points as compared with the saw. The average grit cut-off wheel has many thousands of sharp cutting teeth on the periphery, whereas the saw is limited to only a few. These minute abrasive cutting teeth, when rotating at a speed of 2 or 3 miles a minute, actually cut their way through the work as truly as does a milling cutter.

*Limitations of Use.* There are definite limitations as to the size of stock which can be cut *economically* with abrasive wheels. On the conventional chopper-type machines using 16-in.-diameter wheels, 2-in.-diameter stock is about the maximum for bar stock with satisfactory wheel efficiency, but bar stock up to 6-in. diameter is being cut on special machines with oscillating wheel motion. Tubing is being efficiently cut up to 3½ in. in diameter.

*Types of Abrasives Used.* Different manufacturers use different abrasives in cutting-off wheels. The Norton Company uses aluminum oxide (Alundum) for cutting steel and most other metals; silicon carbide (Cryston) for cutting nonmetallic materials such as carbon, tile, slate, ceramics, insulating board, etc.

*Types of Bond Used.* Again, different manufacturers use different bonds in the manufacture of cutting-off wheels. Norton uses resinoid, rubber, and shellac—all, organic bonds. Each type of wheel has its advantages and special fields of application.



**Bases for Wheel Selection.** For selecting a wheel intelligently, it is necessary to have the following information:

1. Machine and speed.
2. Material and size of stock to be cut.
3. Wet or dry grinding.
4. Requirements as to type of cut necessary (discoloration or burring).

With regard to the type of cut, there are two considerations in dry cutting; discoloration and burring.

*Discoloration.* Discoloration, which is an indication of excessive heat generated in cutting, can be eliminated by improving the cutting action with a different wheel specification. Discoloration is particularly objectionable when machine operations are to follow the cutting off, as it is an indication of surface, or skin hardening, which in turn affects machinability.

*Burring.* Burring cannot be entirely eliminated in dry cutting without a sacrifice of wheel economy. Wheels of finer grit produce a lighter burr, which is easily removed, but generally they have a higher rate of wheel wear than the wheels having a coarser grit.

**Wet Cutting.** There are a number of excellent types of wet cut-off machines on the market, and materials which at one time were considered unable to be cut with abrasive wheels are now being cut successfully by the wet method. The ordinary wet cut-off machine uses a coolant box, which spreads a large amount of liquid over the work, wheel face, and sides, and thereby dissipates the heat normally generated in cutting.

Wet cutting promotes long wheel life. The cut itself is of a high quality; any burr which may be produced is light and easily removed or may even be washed away in the cutting.

Wet, traverse-type machines are particularly adapted for cutting such materials as plate glass, steel slabs, plastics, building brick and refractory brick, copper slabs, and other materials of similar characteristics. The wheels are usually rubber-bonded, although on some of the materials, resinoid-bonded wheels are also being used.

**Low and High Speeds.** Low speed in cutting-off work implies that the wheels are operated at 9,000 to 12,000 s.f.p.m. or less, whereas high speed is generally 15,000 to 16,000 s.f.p.m. To obtain

a peripheral speed of 16,000 s.f.p.m., the following spindle speeds should be provided:

Wheel Diameter, inches	Spindle Speed, r.p.m.
12	5092
14	4366
16	3820

The minimum thickness of *resinoid* cut-off wheels for safe operation at high speed varies as follows, according to the diameter:

Diameter, inches	Thickness, inch
12	$\frac{3}{32}$
14	$\frac{3}{32}$
16	$\frac{1}{8}$

The minimum thickness of *rubber* cut-off wheels for safe operation at high speed varies, as follows, according to the diameter:

Diameter, inches	Thickness, inch
12	$\frac{3}{32}$
14	$\frac{1}{8}$
16	$\frac{1}{8}$

### FACTORS IN THE SELECTION OF GRINDING WHEELS

Before a wheel is selected or wheel specifications are given, the following factors must be considered. Otherwise, the wrong wheel may be ordered or used.

**Constant Factors.** The first constant factor to consider is the *material to be ground*, which influences the selection of the *abrasive*, the *grain size*, the *grade*, the *structure number*, and the *bond*. Some manufacturers recommend that the abrasive to be selected should be Aluminum Oxide for steel and steel alloys, and Silicon Carbide for cast iron, nonferrous metals, and nonmetallics; the grain size, a fine grain for hard and brittle materials and a coarse grain for soft, ductile materials; the grade of wheel, hard wheels for soft materials, and soft wheels for hard materials; the structure number, close grain spacing for hard and brittle materials, and wide grain spacing for soft, ductile materials. The bond selection is at times influenced by

the materials to be ground, but more often by the operating conditions and by the variable factors mentioned later in this section.

The second constant factor to consider is the *accuracy* and the *finish required*. This factor influences the selection of the grain size and the bond. It is recommended that the grain size be coarse for fast cutting and fine for fine finishes. The bond used should be vitrified for roughing and semifinishing, and resinoid, rubber, and shellac for the highest finishes.

The third constant factor to be considered is the *area of contact*, which influences the selection of grain size, grade, and structure number. It is recommended that the grain size be fine for small areas of contact, and that the coarse grain be used for large areas of contact. The grade recommendation is: The smaller the area of contact, the harder the wheel should be. As far as structure number is concerned, the close grain spacing is recommended for small areas of contact, and the wide grain spacing for large areas of contact.

The fourth constant factor to consider is the *nature of the grinding operation*. Here only the bond used is affected. Precision grinding, whether done on cylindrical, internal, or surface grinders, calls for vitrified bonded wheels. In case an exceptionally fine finish is required, as on steel rolls or ball races, one of the organic bonds (resinoid, rubber, or shellac) may be better suited. Snagging or foundry grinding is generally done on low-speed (9,500 s.f.p.m.) machines, which require organic bonds. Cutting-off wheels must either be resinoid-, rubber-, or shellac-bonded.

**Variable Factors.** There are four variable (changeable) factors to consider when one is making the selection of grinding-wheel specifications. These are: *wheel speed*, *rate of feed* or *grinding pressure*, *condition of the grinding machine*, and *operating characteristics of the operator*. Each will be explained in turn.

The first variable factor to consider is the wheel speed, which influences the grade and the bond of the wheel. It is recommended that the grade should be determined in this way: the higher the wheel speed with relation to work speed, the softer the wheel should be. When, for any reason, the wheel speed is reduced, then it may be expected that the wheel will wear faster, but this can be overcome by going to a wheel of a harder grade. (It is assumed that the grade was correct for the initial speed.)

The bond recommended is vitrified for speeds up to 6,500 s.f.p.m.; rubber, shellac, or resinoid for speeds over 6,500 s.f.p.m.

The second variable factor to consider is the rate of feed, or grinding pressure. This affects only the grade of the wheel. The recommendation made in this case is that the higher the rate of feed or the greater the grinding pressure, the harder the wheel should be. When work speed is increased and the feed per revolution of work is kept constant, the rate of feed is automatically increased, which increases the rate of wheel wear and, in turn, calls for a harder grade of wheel.

The third variable factor to consider is the condition of the grinding machine. Spindles that are loose in their bearings and insecure or shaky foundations necessitate the use of harder wheels than would be needed if the machine were in better operating condition.

The fourth variable factor to consider concerns the operating characteristics of the operator which, on offhand grinding, can vary costs as much as 100 per cent on the same work and in the same factory. The man on piecework usually requires a harder wheel than the man paid on a daywork basis.

**STANDARD WHEEL MARKINGS**

Because of the diversity of methods employed by the various grinding-wheel manufacturers in the marking of grinding wheels, a standard method of marking has been adopted by the Grinding Wheel Manufacturers Association.

**Guide to Markings.** This new marking system, accepted as standard for the abrasive industry, is divided into six parts, with the markings placed in the following sequence:

Position 1	Position 2	Position 3	Position 4	Position 5	Position 6
Kind of abrasive and manufacturer's prefix	Grain size	Grade or hardness	Structure	Bond type	Manufacturer's record

*Position No. 1: Kind of Abrasive.* A, aluminum oxide (may or may not be preceded by the manufacturer's prefix). C, silicon carbide (may or may not be preceded by the manufacturer's prefix).



**Example of a Standard Marking-system Chart.** The chart shown in Fig. 13-18 shows how a specific wheel is marked and how it should be ordered from the manufacturer. The chart shows that a grinding wheel marked 51A-36L-5V23 has been chosen. The letters and numbers contained in this identification are explained in the figure.

### EXAMPLES OF WHEEL SPECIFICATIONS

Wheel specifications for two common jobs done in machine shops are here worked out.

**Sharpening a Milling Cutter.** The tool to be sharpened is a high-speed steel milling cutter ground on a tool and cutter grinder, ground dry.

The abrasive recommended is aluminum oxide because steel is to be ground. Since the high-speed cutter is sensitive to grinding (burns easily) choose a cool cutting abrasive, one that stays sharp longer, such as the 32A aluminum oxide abrasive.

As for grain size, because a small amount of material is to be removed, accuracy and finish are important. The wheel must retain size in order that all the teeth of the cutter may be ground to the same diameter or in the same plane. Use a medium-fine grit, about 60.

As for grade, this is a precision job requiring a wheel which will hold its size and have a cool cutting action. Choose a medium-soft grade, about grade J. If a very soft grade, such as H, should be chosen, wheel wear might be excessive. If too hard a grade is used, the wheel will dull and burn the cutting edges.

The structure number should be a No. 5 with 60 grit. This has proved to be an excellent choice in cutter grinding.

As for the bond, it is recommended that the BE bond be used. This is a vitrified bond and is used for 4,500 to 6,000 s.f.p.m.

Combining all *CAPITAL* letters and numbers, we get a developed specification for grinding a high-speed milling cutter as 32A60-J4BE.

**Finishing A Heat-treated Steel Shaft.** The material to be ground is SAE 1090 steel on a 10- by 36-in. cylindrical grinder, ground wet.

*Abrasive.* The shaft is steel and, therefore, is ground best with aluminum oxide or Alundum. The operation is a precision production

job of rough and finish grinding, requiring a relatively light stock removal of about 0.010 in. It is recommended that 57 Alundum abrasive be used because of its uniformly free cutting action, especially suited to production grinding. If the operation required a large stock removal, such as a strictly roughing job, it would be advisable to try the regular Alundum abrasive—a tougher, stronger abrasive.

*Grain Size.* The material is moderately hard. The operation calls for a good commercial finish, which can be obtained with a medium fine grain such as 54 grit.

*Grade.* The material is only moderately hard, and this indicates that a medium grade, such as L or M, can be used.

*Structure Number.* Most cylindrical grinding is done with a medium spacing of the grain—No. 5.

*Bond.* The wheel speed is between 5,500 and 6,000 s.f.p.m. which calls for a vitrified bond. Since 57 Alundum abrasive has already been chosen, BE type vitrified bond is automatically selected.

Combining all *CAPITAL* letters and numbers, we get a developed specification for grinding a cylinder as 57A54-L5V BE.

### RECOMMENDED WHEEL SPEEDS IN SURFACE FEET PER MINUTE (s.f.p.m.)

The speed at which a grinding wheel revolves is important. Too slow a speed means wastage of abrasive without much useful work in return, whereas an excessive speed may result in hard grinding action and may introduce the danger of breakage. In general, it is better to operate a grinding wheel at somewhere near the speed

**Table of Recommended Wheel Speeds**

Type of Grinding	Wheel Speed, s.f.p.m.
Tool and cutter grinding	4,500- 6,000
Cylindrical grinding	5,500- 6,500
Internal grinding	2,000- 6,000
Surface grinding	4,000- 6,000
Wet tool grinding	5,000- 6,000
Rubber, shellac, and resinoid cutting-off wheels	9,000 16,000*

\* This higher speed is recommended only where bearings, protective devices, and machine rigidity are adequate.

recommended by the maker, as he has found by years of experience that certain speeds work better than others.

### HANDLING, STORAGE, AND INSPECTION

**Handling.** All grinding wheels are breakable and some are very fragile. Great care should be used in handling and storage to prevent damage which might cause a wheel to fly apart when brought up to speed. The following rules which are based on experience, should always be observed:

1. Handle wheels carefully to prevent dropping or bumping.
2. Do not roll wheels (hoop fashion).
3. Use trucks or suitable conveyers which will provide proper support for all transportation of wheels which cannot be carried by hand.
4. Stack wheels carefully on trucks. Do not pile heavy castings or tools on top of them or permit wheels to topple over.

**Storage.** Suitable racks, bins, or drawers should be provided to accommodate the various sizes or types of wheels used. Wheel-storage rooms should not be subject to extreme temperatures and should always be kept dry.

**Inspection.** Immediately after they are unpacked, all wheels should be closely inspected to make sure that they have not been injured in transit or otherwise. As an added precaution, wheels should be tapped gently, while suspended, with a light implement, such as the handle of a screw driver for light wheels, or a wooden mallet for heavier wheels. If they sound cracked, they must not be used. The wheels must be dry and free from sawdust when the test is applied. Otherwise, the sound will be deadened. It should also be noted that organic bonded wheels do not emit the same clear metallic ring as vitrified and silicate wheels.

### DIAMONDS AND DIAMOND WHEELS

Before the chapter on grinding wheels is completed, something may be said about diamonds and diamond wheels used in machine practice. For many years, a certain amount of very accurate grinding has been done with small steel disks having the periphery impreg-



nated with diamond dust. These little wheels, when used for internal grinding, were often called *diamond laps*. Today, however, the commercial diamond is being used to a very large extent in industry wherever a very hard substance is needed for such operations as grinding and grinding-wheel dressers.

The diamond is the hardest substance known. Because of this, it can cut any other substance, no matter how hard.

The diamond is carbon in crystalline form, varying from clear, transparent stones to tinted varieties colored by small amounts of impurities—through translucent to completely opaque stones. The impure, opaque stones (usually called *borl*) are those ordinarily used in the machine industry and are known as *industrial* diamonds, because of their service to industry. They are not very expensive when compared to the clear, blue-white diamonds of the jewelry trade. The principal source, of diamonds in the world is South Africa, with Brazil in second place.

In grinding, diamonds have two functions: to true and dress the faces of abrasive wheels, which they cut easily, and, dispersed in graded grain size in various bonding materials, to act as grinding wheels for cutting especially resistant substances—notably, glass, stone, ceramics of all kinds, and cemented carbides.

Since the advent of cemented-carbide cutting tools, and the resulting need of abrasive wheels suitable for sharpening the carbide lathe tools, milling cutters, etc., the commercial diamond wheels, in straight-, cup, and dish-wheel shapes, and special wheels for form grinding, have been developed. Diamonds are crushed under heavy wheels of very hard material, such as manganese steel, and then screened to get the standard grain sizes, 100, 180, 200, 240, 320, and 400. Mixtures of diamonds and bond are made in different *diamond concentrations*, that is, with varying proportions of diamonds per volume of mixture. The given mixture is coated on the working surface only of the wheel shape, which is of special composition material. The coating is applied in regular thicknesses of  $\frac{1}{32}$ ,  $\frac{1}{16}$ , or  $\frac{1}{8}$  in., as ordered.

Naturally, these diamond wheels are expensive, as to first cost, but carbide tools can be reconditioned in a fraction of the time required with other abrasive wheels, and a sharp, smooth edge is obtained without hand lapping. The price is based upon (1) the size

of the wheel, (2) diamond concentration—A, B, or C, C having four times as many carats as A per unit volume of coating, and (3) the thickness of the coating. Of course, the wheel having a  $\frac{1}{8}$ -in. coat will last four times as long as the wheel having a  $\frac{1}{32}$ -in. coat; but it seems true, with respect to the concentration, that a higher degree of finish and longer wheel life are obtained with the use of the *lower* diamond concentration, and at only a slight loss in production.

**Advantages of Diamond Wheels.** Unlike the manufactured abrasives, the diamond does not fracture in service. When it dulls on the cutting edge or point, the pressure rises and with it the temperature, the grains of the wheels are no longer fractured, and the wheel is glazed rather than dressed. Good practice, therefore, calls for protective measures against excessive wear.

**Care and Use of Diamond Wheels.** Extreme care must be taken in mounting the diamond wheel. It should run at about 5,000 s.f.p.m.—never more than 6,000. It is best to use *plenty* of coolant—water or soda water, or a grinding solution. The art of grinding carbide tools involves knowledge, skill, and care to avoid waste of the wheel and the tool. What is stated here is meant only as an introduction; the care and use of the diamond wheel is fully illustrated and described in booklets published and sent free by the manufacturers; for example, The Carborundum Company, Niagara Falls, New York; and the Norton Company, Worcester, Massachusetts.

## WHEELS FOR GRINDING CARBIDE TOOLS

In 1928, a new cutting-tool material, known as *cemented tungsten carbide*, was made available to American industries. Since that time, this material has been the subject of concentrated development efforts on the part of both producers and users of cemented carbides. The producers have been responsible for the introduction of variations in composition, known as *grades*, in order to fit machining requirements, while the users have aided considerably in the problem of tool design and in the establishment of proper methods of application.

Since the cemented carbides cannot be machined in their final form by any known metal tool, they must be shaped by grinding. Thus, grinding is one of the most important operations in the manu-

facture, use, and maintenance of carbide cutting tools. It should be remembered that, inasmuch as they are entirely different from the high-speed and cast-alloy cutting materials, both in composition and in physical properties, the carbides require special grinding wheels and a different grinding technique, in order that the most efficient and economical service may be obtained from them.

Cemented-carbide tools can be ground readily with either the Silicon carbide abrasive wheels or with the diamond wheels. The Aluminum Oxide wheels used for grinding steel are not suitable for grinding this material and should *never* be used on carbide tools except for grinding the steel shanks.

**Green Silicon Carbide Wheels.** Of the two types of silicon carbide abrasive wheels produced by the Norton Company, the green-colored variety is generally preferred for grinding the cemented carbides. In the wheel markings this abrasive is designated by the number 39 before the letter C (for silicon carbide abrasive). The familiar gray—almost black—variety is also used for carbide grinding wheels and is identified by the number 37 at the beginning of the wheel marking.

**Grit Size.** The grit size of wheel to be used depends largely upon the nature of the grinding operation and, to some extent, upon the grade of carbide being ground. For rough grinding, emphasis is placed upon stock removal, and a relatively coarse grit size, 60, is necessary. In finish-grinding, however, stock removal is not a problem, and since the finish is directly dependent upon the grit size of the wheel, a finer grit size, such as 100 or 120, is required.

**Grade.** Because the cemented carbides are extremely hard and brittle, they are subject to injury from the internal stresses resulting from the heat generated by the grinding, or by grinding with dull wheels. For this reason, Crystolon (Norton Company's trade name for Silicon Carbide) wheels for carbide grinding are purposely made soft, so that the abrasive grains are removed as they become dull. A harder wheel may appear to give better results at first, but soon there will be many damaged tools, owing to the hardness of the wheel.

**Diamond Wheels for Grinding Carbide Tools.** Diamond wheels have become the accepted abrasive wheels for offhand *finish-grinding* carbide single-point tools and for precision grinding

operations on cemented carbides, including the grinding of chip breakers, face mills, reamers, etc. Their advantages of exceptionally fast and cool cutting action and extremely low rate of wear, as compared to Silicon Carbide wheels, resulting in low grinding costs, are well known to every tool-grinder hand who has used diamond wheels.

For a complete description of diamond wheels, see pages 451 to 453.

### QUESTIONS ON GRINDING WHEELS

1. Name the four groups into which the abrasive tools of the machine shop are classified.
2. Name and give the function of each of the four basic elements of a grinding wheel.
3. Name two abrasives used in the manufacture of grinding wheels.
4. Describe each of the abrasives named in question 3.
5. What is meant by grain size? Give two examples of grain sizes.
6. Describe the function of the abrasive grain in a grinding wheel.
7. Define bond. What is its function? Name at least three different bonds used in the manufacture of grinding wheels.
8. Explain what is meant by the grade of a wheel.
9. What is meant by structure in a grinding wheel?
10. Name five standard grinding-wheel shapes and name two uses for each shape.
11. What is a mounted wheel? When is it used?
12. What is a cut-off wheel? When is it used?
13. Materials may be ground dry or wet. Name some advantages and disadvantages of each type of grinding.
14. Name and explain the factors to be kept in mind in selecting a grinding wheel.
15. Identify the following standard markings on grinding wheels: (a) C80-K7-S20; (b) A150-G8-R30.
16. Why is the speed at which grinding wheels are operated important in machine-shop practice? What is the unit used in specifying wheel speeds?
17. How should wheels be handled, stored, and inspected?
18. Give four suggestions concerning the use of diamond wheels.
19. Why are special grinding wheels used in grinding carbide tools? Name the wheels used for grinding carbide tools.

## Grinding Principles and Practice

Grinding is the process of removing metal by means of an abrasive wheel. The results which may easily be obtained, with the proper wheel in a well-made machine intelligently operated, are extreme accuracy, a fine finish, and rapid production. The work may be of any size or shape within the capacity of the machine, and of practically any of the materials, hard or soft, used in machine construction. The grinding machine is the standard machine tool for the accurate sizing of hardened pieces.

The grinding machine is used primarily for finishing surfaces that have previously been roughed out in another machine; hence its value lies not in the amount of metal removed in a given time but in the accuracy of its product and in the ease by which this accuracy may be obtained. That is, cylindrical or tapered pieces finished in a grinding machine may be produced in a way that is quicker, better, and cheaper than they could if they were turned to exact size. Holes in many of the parts made of the tough alloy steels, or even of cast iron, may be ground more easily and quickly than they can be bored to size or reamed; and many flat surfaces may be finished and accurately sized in the surface-grinding machine, especially with the use of the magnetic chuck, more efficiently than in any other machine. A surface properly ground is beautifully smooth and free from feed marks, scratches, or chatter marks.

In this chapter certain definitions are given, and the factors of wheel speeds, work speeds, arc of contact, etc., as they enter into the successful practice of grinding, are described. The selection, mounting, and truing of the wheel, and the setup of the job are discussed in detail.

**Safety on the Grinder.** In the operating of any type of grinder, the personal safety precautions listed here should be observed.

1. Wear safety goggles at all times when performing any operation on any grinder.

2. See that all safety equipment (guards and hoods) is in place.

3. In offhand grinding, keep the work rest adjusted close to the wheel. A maximum distance of  $\frac{1}{8}$  in. is recommended to prevent the work from being caught between the wheel and the rest.

4. Securely clamp the work rest after each adjustment.

5. Avoid personal contact with the moving wheel or work.

6. Keep shirt sleeves rolled up.

7. Do not wear a tie or if you must wear a tie, wear a bow tie.

8. Keep your shirt inside your trousers. Any loose portion of your shirt may get caught between the fast-moving wheel and the work and draw you into the machine.

9. Wear a cap. Long, unruly hair is dangerous.

10. No "fooling around" or "horseplay" is in order. Remember that there are other people working near and around you. Their safety *must* be considered.

The following safety measures should be practiced as far as the grinding machine and wheels are concerned.

1. Make sure that the work is securely and properly clamped.

2. Make sure that the wheel is properly mounted on the machine.

3. Make sure that the wheel is "sound," that is, that the wheel has no fractures or breaks in it before mounting.

4. Be sure that you *know* the safe operating speed of the wheel you are using. Always ask your foreman or instructor if you are not sure about the speed. Do not depend upon your memory.

**Kinds of Grinding.** By *cylindrical grinding* is meant the grinding of outside cylindrical surfaces. External tapers and angles may be ground, and the same principles of wheel action, work speeds, wheel speeds, etc., apply as in cylindrical grinding. By *internal grinding* is meant the grinding of holes, either straight or taper. By *surface grinding* is meant the grinding of horizontal flat surfaces. When the flat surface being ground is vertical, the operation is called *face grinding*. In face grinding, the face (periphery) of the wheel may be used, as when the side of a revolving disk is being ground; or the side of

the wheel may be used if it is undercut a trifle (Fig. 14-24), or a cup wheel may be used.

In the grinding of cylindrical, taper, or angular pieces, whether external or internal, several cuts are usually taken by the *traverse method* of grinding. That is, automatic cross-feed for the wheel is set to operate a definite infeed for each pass, and the longitudinal feed (traverse) is set for a certain amount each revolution of the work.

Frequently, in the grinding of comparatively short work, with not more than 0.010 or 0.012 in. to be removed from the diameter, it is advisable to set the wheel to grind the correct diameter and then grind the succeeding pieces without changing the cross setting of the wheel, except occasionally, to compensate for the wear of the wheel. This is spoken of as *set-wheel grinding*.

In recent years, plain grinding machines have been designed to permit the use of wide-faced wheels, and in manufacturing operations it is not uncommon to find wheels with up to 8 in. of face. When the work is shorter than the width of the wheel face, it does not have to be traversed; it is only necessary to feed the wheel in as the work revolves. This is called *infeed* or *plunge-cut grinding*.

With the wide-faced wheel and a suitable fixture for dressing the wheel to a given outline, it is possible to grind a more or less irregular surface, as, for example, in crowning pulleys, finishing handles, etc. This is termed *form grinding*. Form grinding is not recommended for work in which there are sharp corners to finish or in which the difference between the largest and the smallest diameter of the work is more than  $\frac{1}{2}$  in.

*Centerless grinding* is discussed on page 492.

**Factors in Successful Grinding.** The beginner in grinding is quite likely to think that too much emphasis is put on the *wheel*. It may seem that a great deal of time is taken to explain about the *making* of the wheel, the *selection* of the wheel for the job, the *care* of the wheel, and the *action* of the wheel. But it must be remembered that in no other machine is the cutting tool so preponderantly a factor in efficient operation. For example, a machinist, to do a good job of drilling or milling, does not have to select a twist drill or a milling cutter of a certain kind of high-speed steel, and with a certain grade, grain, and structure—one cutter or drill for cast iron, another for

steel; but, in grinding, the kind of wheel, and the grain, grade, and structure, are very important.

In any grinding operation, the rapidly revolving abrasive wheel is the cutting tool. The surface speed of the wheel, in feet per minute, is called the *wheel speed*. In external cylindrical or taper grinding, and in a large number of internal jobs, the work revolves, and in most surface grinding the work passes under the wheel. The speed, in feet per minute, that the surface of the work is being ground, is called the *work speed*. The direction of the revolving work, as in cylindrical grinding, is *against* the wheel rather than with it; in reciprocal surface grinding, a cut is usually taken in both directions—one with, the other against, the direction of the wheel.

It should be made clear that the best wheel *acts* best only when the *total* of wheel, wheel speed, work speed, and cut (feed) is right. That is, each depends upon the other; changing any of the last three will serve to change the *action* of even an ideal wheel. While this may seem, at first, to draw the line very fine, it really is fortunate, because it works both ways—if the wheel is not quite the best for the purpose, its action may be improved by changing the work speed, or possibly the wheel speed.

In production grinding, the wheel of known classification, the wheel speed, and the work speed are decided upon, the setup is made, and production goes forward. The foreman must know about the selection, care, and use of wheels. In general machine work and toolmaking, the man on the machine must know how to select the wheel, mount it on the machine spindle, dress it properly, set up the job, and grind the given surface.

In addition to its shape and size, the factors to be considered in the selection of a grinding wheel and the setup for a given job are: (1) The kind of wheel (the bond) to use. (2) The kind of material to be ground; whether to use a wheel made of aluminum oxide or silicon carbide. (3) The arc or area of contact, for example, whether external, internal, or surface grinding. (4) The finish desired. On these factors depend: (5) The grain, grade, and structure of the wheel. In getting the wheel ready, setting up, and starting to grind, the considerations are: (6) Mounting the wheel. (7) Dressing the wheel. (8) Setting the wheel speed. (9) Setting the work speed. (10) Setting the amount of cross-feed. (11) Setting the table traverse (long feed).



(12) Setting the table-reverse dogs. These factors may appear involved, but they are not difficult to understand if one enters, step by step, into the reasons underlying each. Explanations follow.

**Arc and Area of Contact.** The distance the cutting edge moves through the metal while peeling off its chip is the arc of contact of the wheel and the work. As the diameter of the work increases, the given wheel has a longer arc of contact, cuts a longer chip. Removing the same amount of metal in a given time taking *longer* chips means taking *thinner* chips. Taking a long, thin chip requires less cutting pressure than removing the same amount of metal by a shorter, thicker chip. Hence, the given wheel will wear longer, that is, it will *act* harder, when grinding the longer chips off the larger diameters. For instance, a wheel that is right for tool steel 1 in. in diameter at 25 ft. per min. will appear too hard when grinding tool steel 3 in. in diameter at 25 ft. per min. This is why it is advisable to use softer wheels for larger diameters, still softer for surface grinding and softer yet for internal grinding.

The same reasoning holds true with respect to variations in *area of contact*. In surface grinding, for example, with cup or with cylinder wheels, the area of the wheel and work contact is much greater than in cylinder grinding, or than it is in surface grinding with a straight wheel. The larger the area of contact, the softer the wheel should be. Further, the larger or broader the contact, the greater must be the "chip clearance," to avoid excessive heating of the work. Chip clearance may be increased by using a coarser grain or a more open structure, or both.

**Mounting the Wheel.** Before being mounted, every wheel should again be closely inspected and rung after it has come from the stock room, to make sure that it has not been fractured while in stock or through subsequent handling. Any evidence of a loose or shifted bushing should be carefully looked for, particularly on a wheel that has been rebushed or remounted by the user. Also see that the bushing does not extend beyond the side of the wheel.

See that the wheel slips freely on the spindle without binding. In general, the hole size should be about 0.005 in. larger than the spindle diameter for hole sizes larger than 5 in. In case the wheel shows a tendency to bind, the bushing should be very carefully scraped or reamed, to give an easy, sliding fit.

As illustrated in Fig. 14-1, there must be a flange on each side of the wheel, and these flanges must be of *equal diameter*. All flanges must be relieved in the center, so that the bearing surface will be on the outer, unrelieved portion of the flange.

The inner flange should be keyed or otherwise fastened to the wheel spindle. When the wheel is being mounted on the spindle, it should be pushed snugly against the inner flange with a blotter (often called a *washer*) between them.

Wheel blotters or washers no smaller than the flange diameter *must* be fitted between the wheel and the flanges. Blotting-paper washers must not be thicker than 0.025 in.

Check to make sure that the wheel bears uniformly around the bearing surface of the flange.

Place another wheel blotter on the outside of the wheel and fit the

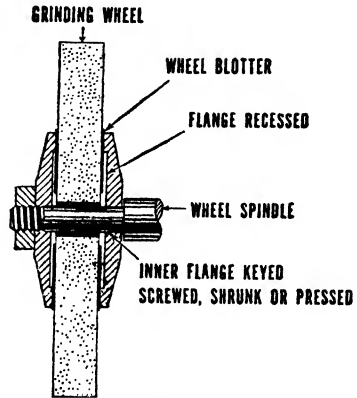


Fig. 14-1.

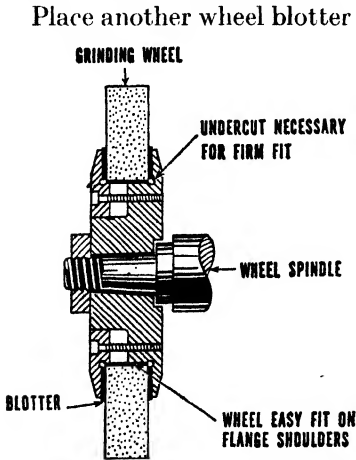


Fig. 14-2.

outer flange against it and the wheel. Check again, to make sure that the flange bears against the wheel uniformly. The outer flange should have an easy sliding fit on the spindle, so that it can adjust itself slightly to give a uniform bearing on the wheel and the blotter. Tighten the spindle end nut against the flange enough to hold the wheel firmly. However, it should not be tightened with too great a pressure, as excessive strains may be set up in the wheel.

The above procedure is also followed in the mounting of wheels with large holes. With this type of wheel, the arbor hole fits on a boss which is an integral

part of the heel mount or flange. See Fig. 14-2 for a correct mounting setup.

It is essential that the wheel be balanced after mounting. After the wheel has been balanced and when a new wheel or one that has been remounted is first started up, it is advisable to stand to one side and allow the wheel to run at full operating speed for at least one minute. Then the wheel should be trued with an approved dressing tool. This will eliminate any eccentricity due to mounting.

**Truing and Dressing a Grinding Wheel** (Fig. 14-3). These two terms were formerly synonymous but are now used to indicate two

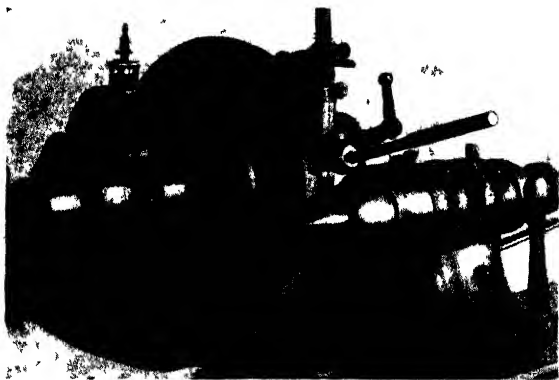


Fig. 14-3. Dressing the face of a grinding wheel

distinct purposes. *Truing* is the operation of *shaping* a wheel to make it run true, or to give it a desired shape. *Dressing* is the operation performed to make the wheel cut better; it may be strictly a *sharpening* operation, when the crystals in the wheel face become too much dulled before automatically breaking away; or it may be a necessary *dressing* operation when the wheel is "loaded" (see page 470).

It should be stated here that, while the ideal wheel would "automatically sharpen"—that is, the crystals, when just sufficiently dulled, would either fracture or entirely break away from the face of the wheel and thus present new cutting edges—this ideal condition is not fully realized in practice, and therefore occasional dressing is required.

**Types of Wheel Dressers.** Many types of wheel dressers are used in the machine shop. Some are called *mechanical*, some *precision*

type, etc. A brief explanation will be given of the more popular types of dressers.

*Mechanical Dressers* (Fig. 14-4). There are several different styles of mechanical dressers that incorporate the action of revolving cutters. The "Huntington" is a popular type in which pointed steel disks, or star cutters, are mounted on a spindle and separated by thin disks. This is available in several different sizes, the most common of which has cutters  $1\frac{1}{4}$  in. in diameter and is intended for dressing wheels up to 10 in. in diameter with a 2-in. face.

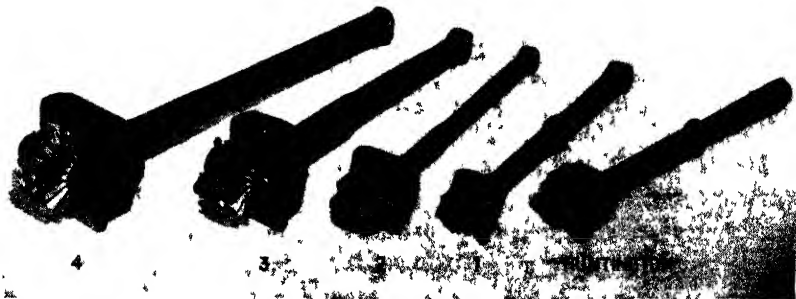


Fig. 14-4. Norton revolving cutter-type dressers. Left to right: No. 4, No. 3, No. 2, No. 1, Huntington (*The Norton Company*)

The No. 1 Norton dresser has four twisted steel cutters  $1\frac{1}{8}$  in. in diameter and is used mostly on wheels of small diameters mounted on bench-stand grinders. The No. 2 has four twisted cutters  $1\frac{7}{8}$  in. in diameter and is recommended for dressing medium-coarse and hard wheels mounted on small and medium-sized floor-stand grinders. The No. 3 dresser is designed for use on large, coarse, and hard vitrified wheels mounted on large floor stands for rough grinding and snagging. This dresser has two corrugated cutters  $2\frac{3}{8}$  in. in diameter. The No. 4 dresser is the same as No. 3, except that it has three corrugated cutters to a set.

For dressing high-speed resinoid- or rubber-bonded wheels, a heavy-duty type of Huntington hand dresser is available. The cutters, either 2 or  $2\frac{3}{8}$  in. diameter, revolve on ball bearings.

*Precision-type Mechanical Dressers.* Special types of mechanical dressers are used on precision-grinding machines in place of dia-

monds. One such dresser is illustrated in Fig. 14-5. It is known as a *Ross dresser*, so-called because it is manufactured by the Ross Manufacturing Company. This particular dresser is recommended for excellent commercial finishes.



Fig. 14-5. Grooved shell-type dresser, recommended for commercial finishes (Ross Manufacturing Company)

*Abrasive-stick Dressers* (Fig. 14-6). For shaping and dressing wheels for saw gumming and form grinding, as well as for general toolroom work, silicon carbide abrasive sticks can often be used in place of more expensive diamond dressers. The round abrasive dressing stick mounted in a holder is illustrated.

*Diamond Truing Devices.* For precision grinding where accuracy and high finish are required, the diamond is still the most popular truing device. The extreme hardness of the diamond ensures its accurately imparting a true surface to the face of the grinding wheel.

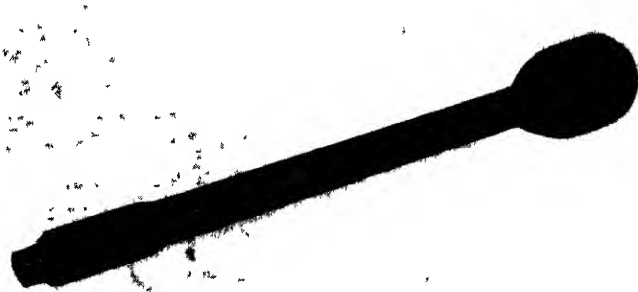


Fig. 14-6. Round abrasive dressing stick mounted in holder. (Desmond-Stephan Manufacturing Company)

Among the more recent developments in diamond dressers are those shown in Fig. 14-7, incorporating the action of small, whole diamonds, permanently mounted and available in several different styles.

**Diamond Dressing Tool** (Fig. 14-8). There are many ways of mounting the diamonds, single and multiple, in the various shapes

and kinds of holders. These commercial practices cannot be treated here, but a word may be said about the diamond itself, and a few directions given for its use.



Fig. 14-7. Diamond truing tools (The Norton Company)

Industrial diamonds, unsuitable for gems for one reason or another, are of two general kinds, the *black diamond* (carbonado) and the *bort*. The black diamond is the hardest known substance, harder than any gem diamond or bort. They are found mostly in Brazil. Most of the borts come from the diamond mines in South Africa, but are not usable for cutting into gems.

The effectiveness of diamonds is largely dependent upon the shape, and the shape upon the cleavage planes. The black diamonds have no distinct cleavage planes, are cross-grained and therefore blunter. They are used in rock drills, etc., while *borts*, having sharper cutting edges, are preferred for machine-shop use, both as grinding-wheel dressers and as cutting tools for fiber, hard rubber, vulcanite,



Fig. 14-8. Diamond dresser with sintered-matrix mounting. (Industrial Diamond Tool Company)

and other materials that dull steel tools quickly. They are used also in making diamond wheels (see page 451). Brown borts are recommended for average wheel-dressing tools.

**DIRECTIONS FOR USING THE DIAMOND TOOL**

1. Provision is usually made for holding the diamond tool in the machine or by means of an attachment and, except when unavoidable, the wheel should never be dressed "by hand."
2. Do not use a small diamond on a heavy wheel.

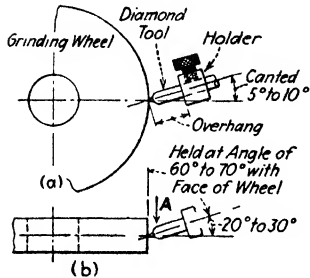


Fig. 14-9. Dressing a grinding wheel.

3. Be sure the diamond itself is securely held in its setting before taking the diamond tool from the tool crib.
4. The diamond tool should be securely and rigidly held, with minimum overhang, and "canted" a 5- or 10-deg. angle, that is, with the handle raised as in *a*, Fig. 14-9. Canting it in this way prevents chattering and the tendency to "dig in." If in doubt as to the wheel center line, lower the tool  $\frac{1}{8}$  in. for safety.
5. Also it is preferable to hold the tool about 60 or 70 deg. with the face of the wheel as in *b*, Fig. 14-9. Feed against the point (arrow *A*) for the first one of two passes, and in the opposite direction for the very light finishing cut.
6. Do not use one spot on the diamond too long; a changed contact on the wheel each setting will tend to keep the diamond sharp. A dull diamond will not properly dress a wheel.
7. In the setup of the diamond tool, *be sure that the holder will not be touched by the wheel*. It is very easy to grind away the "setting" and lose the diamond.
8. Do not overheat the diamond; use plenty of coolant or, if dry-grinding, allow cooling intervals.
9. Move the diamond across the face of the wheel quite slowly.
10. Do not have diamond cuts over 0.001 in. deep.

**GRINDING PRACTICE**

**Setting the Work.** Measure the first piece, or pieces, and do not grind any one to size before the machine is correctly set for the job.

That is, do not run the chance of spoiling the first piece, or even the second, by grinding too close to size before the machine is set right.

The amount of stock to be left for the grinding operation depends largely on the character of the work, whether the piece is long or short, stocky or slim, what the material is, if it is to be hardened, what the facilities are for straightening, and the nature of the turning (whether it is fairly smooth or not). It might be good practice to leave only 0.005 in. on one piece, while on another piece it would be economical to leave  $\frac{1}{32}$  in. for grinding. This is a matter of judgment and requires experience. Manufacturers usually supply limit gages<sup>1</sup> to the lathe hands who rough-turn the work. Have the centers and center holes in first-class condition and *clean*. If the work is to be chucked or held in a vise or clamped otherwise, have the holding device and the work clean, and be extremely careful in clamping. Remember that a very little dirt or a slight stress that will twist or buckle or bend the work will defeat good grinding.

**Setting the Wheel Speed.** A speed too slow causes the wheel to act too soft and wastes it. Too fast a speed causes a hard grinding action and may cause the wheel to break. The surface speed of an abrasive wheel with either vitrified or silicate bond should be from 6,000 to 6,500 s.f.p.m. It may be advisable to run it slower to have it act softer, but it is dangerous to run it faster than 6,500 s.f.p.m.

Wheels with organic bonds may be run faster; certain cutting-off wheels with resinoid bond may be run at 15,000 s.f.p.m. The maximum safe speed is printed on the ticket with the new wheel. With an old wheel, when in doubt play safe (6,500 s.f.p.m.).

Do not get revolutions per minute confused with surface speed. As the size of the wheel decreases noticeably, the revolutions per minute may properly be increased. Remember always that, when a wheel of larger diameter is substituted for a smaller wheel, the speed of the spindle should be *decreased*.

<sup>1</sup> *Limit Gage.* A double gage having one dimension larger and the other smaller than the nominal size. With narrow limits these gages are valuable for testing the finished product. They are also much used in lathe work (rough turning) with wider limits over and under the nominal turning dimension.



**RULE 1:** To obtain surface speed, diameter of wheel and revolutions per minute given, multiply revolutions per minute by one fourth the diameter of the wheel or

$$\text{Surface speed} = \frac{\text{r.p.m.} \times D}{4}$$

**RULE 2:** To obtain the necessary number of revolutions per minute to give the desired surface speed, having given the diameter of the wheel, divide the surface speed required by one fourth the diameter of the wheel, or

$$\text{R.p.m.} = \frac{4 \times \text{surface speed}}{D}$$

**Setting the Work Speed.** The grinding wheel can do only so much cutting. Bearing a tool too hard on the wet grinder does not sharpen it any faster but does result in wearing the wheel and possibly in overheating the tool. By the same principle, revolving the work too fast (which has the same effect as bearing too hard) in the grinding machine does not produce more work but results in wearing the wheel and possibly in injury to the work.

There is a ratio between the work speed and the wheel speed that will result in an efficient wear of the wheel, and this ratio may be approximated in any grinding machine. It is this ratio of work speed to wheel speed that determines the forces acting on the wheel face that tend to break or dislodge the crystals of abrasive, and by regulating one or the other of these speeds (preferably the work speed) the approximate balance or ratio to give the ideal "breaking down," or automatic sharpening action, may be obtained. Thus, as the work speed is increased in ratio to the wheel speed, the stresses are increased and the wheel *acts* softer, that is, it is broken down faster. Therefore:

1. If, in grinding, the wheel acts too soft—wears rapidly, does not hold its size—decrease the work speed (or, possibly, increase the wheel speed).

2. If the grinding wheel acts too hard—glazes, and heats the work too much—increase the work speed (or, possibly, decrease the wheel speed).

As a help to the beginner the following table of (average) work speeds is given:

Surface Speed of Work in Feet per Minute

Operation	Soft steel	Hardened steel	Cast iron	Bronze
Roughing	50	25	40	60
Finishing	75	40	60	75

For finishing, the cut is lighter and the work speed may be increased as noted in the table.

**Setting the Table Feed.** The more cutting edges of a suitable wheel that come in contact with the work in a given time, the greater the production. Consequently, in traverse grinding, if the nature of the work will permit and maximum production is expected, the table feed for roughing should be arranged to move the work an amount slightly less than the width of wheel face each revolution of the work. In finishing, the work speed is increased and the table traverse is usually unchanged, which results in a feed considerably less than the full width of the wheel face.

Where possible, it is a good plan to set the reverse dogs to allow a portion, if not all, of the wheel face to extend beyond the end of the surface being ground.

In universal grinding machines the width of wheel used is not usually over 1 in., but plain grinding machines are built which take a wheel with a 10-in. face. When the length of the surface being ground is less than the face of the wheel, it is unnecessary to traverse the work. The infeed method of grinding is used.

**Setting the Depth of Cut.** Given a wheel of proper grain and grade, the right wheel speed and work speed, then the depth of cut is limited only by the nature of the work and the power of the machine. The idea that, in grinding, a series of infinitesimal cuts should be taken is wrong. It is safe to say 1,000 cuts are taken that are too light to one that is too heavy. The usual faults in infeeding are (1) irregular hand feed and (2) too light a feed. It is practically impossible to feed by hand without sometimes feeding too much and at other times too little; *use the automatic feed.* Do not take one tooth

of feed for roughing, take eight or ten teeth; and very likely the job will stand twice that or even more.

**Causes of Inaccurate Work and Imperfect Appearance.** Time may be wasted by the use of a wheel so soft that it will not hold its shape the whole length of cut, and poor work may be the result. This is especially true in surface grinding. Most of the spoiling of ground work is, however, caused by the heating and consequent warping of the work, owing to a hard wheel, a dull wheel, or a loaded wheel. Chatter and waviness in the work may be caused by the wheel spindle's being loose in its bearing, the wheel being out of balance, or the wheel's being clogged with chips, but the most frequent cause is the wheel's getting out of shape, either out of round, or with the face not parallel to the cut. *Keep the wheel clean and true and sharp.*

#### **Causes of Wheel's Wearing Too Rapidly**

1. Wheel too soft.
2. Face of wheel too narrow.
3. Speed of wheel too slow.
4. Speed of work too fast.
5. Crowding the wheel.
6. Holes or grooves in the work.

#### **Causes of Wheel's "Glazing"**

1. Wheel too hard.
2. Grain too fine.
3. Wheel speed too fast.
4. Work speed too slow.
5. Wheel loaded with chips.

**Causes of Wheel's Loading.** In the grinding of soft materials such as brass, bronze, aluminum, and even soft steel, there is a tendency for the chips to wedge in between the cutting points of the wheel in the same way that a file is loaded. Figure 14-10 shows the face of a grinding wheel severely loaded. This is especially true when the wheel has too dense a structure or is too hard, or when the work is running too slowly. The remedy is to do one or more of the following: Select a softer wheel or one with more open structure; increase the

work speed; decrease the amount of chip, and perhaps the amount of table feed if the width of the cut seems to cause the work driving belt to slip. Figure 14-11 shows the same wheel (Fig. 14-10) after it had been properly dressed.

**Advantage of Using Dead Centers in Grinding.** The work, revolving with the headstock spindle, may be held on centers, in a

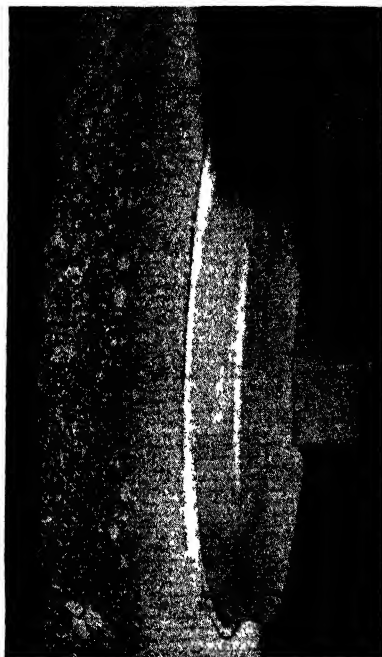


Fig. 14-10. Face of a grinding wheel severely loaded. (*The Norton Company*)



Fig. 14-11. Same wheel after proper dressing. (*The Norton Company*)

chuck, on a faceplate, or directly in the taper hole of the spindle. In addition, the grinding machine is provided with means of driving the work on dead centers.

The work itself, having good clean centers and ground *on dead centers* in the machine, must come true and absolutely concentric. If, however, the live center revolves with the work, any fault in the spindle bearings will affect the accuracy of the work. Moreover, if

the live center runs out ever so little, the work in being ground will be that much out of center, or eccentric.

**Use of Back Rests, or Steady-rests.** The back rest, or "steady-rest," is necessary for grinding slender work (Fig. 14-12). Grinding-

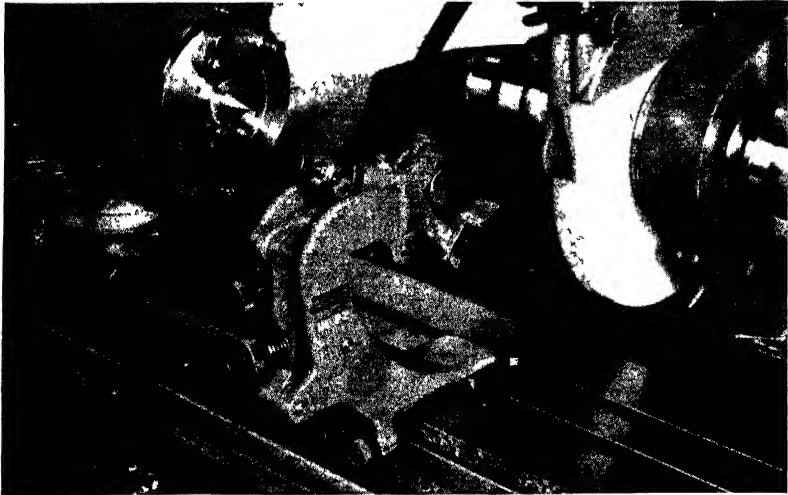


Fig. 14-12. A back rest (*The Brown & Sharpe Manufacturing Company*)

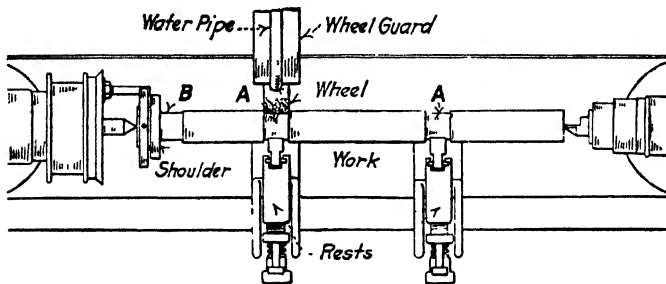


Fig. 14-13.

machine manufacturers have developed back rests which have considerable flexibility when the work is in the rough, but which are provided with positive stops that ensure the accuracy of the finished piece (see Fig. 14-14). That is, they may be adjusted to compensate for work which is considerably oversize, out of round, or slightly

bent. When, however, a plain rest is used (and often in the case of a compensating back rest), it is advisable to "spot" the work for the rest by feeding the wheel in by hand until the diameter is 0.002 or 0.003 in. oversize (see *A*, Fig. 14-13). This operation takes only a short time, eliminates much of the tendency for the work to chatter, and makes for longer life of the shoe.

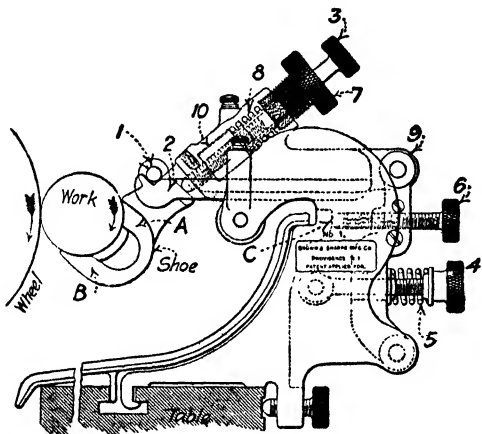


Fig. 14-14. Brown & Sharpe universal back rest or steady-rest.

The detail in which Brown & Sharpe give the following instructions for the use of their back rest (Fig. 14-14) indicates the importance of care in the art of grinding.

To adjust the universal back rest proceed as follows:

1. Select shoes the size of the finished work, and hook the trunnions 1 into the V-bearings 2.
2. Turn screw 3 back far enough to allow the shoe to clear the work, and loosen nut 4 to relieve entirely the pressure on spring 5. Turn back screw 6.
3. Turn forward the screw 7 until a light pressure is given to the spring 8. Turn forward the screw 3, and, if the spring 5 is wholly relieved and the screw 7 is far enough back, the shoe will come in contact with the work at both points *A* and *B*.
4. Press lightly with the thumb on 9, holding the shoe in gentle contact with the work, and turn the screw 6 carefully, noting the slightest touch of the end against the stop *C* in order that none of the parts be moved. With this screw in contact with the stop, the shoe should bear alike at both points *A* and *B*. Turn nut 4 to give some pressure to the spring 5. The

combined pressure of the springs 5 and 8 should be only sufficient to resist the pressure of the wheel when taking the last cut and to prevent vibration of the work under any cut that it may be desirable to take. Tighten the clamping screw to hold screw 3.

5. Grind the trial piece of work, moving the screw 3 to maintain the contact of the shoe with the work and the screw 6 to preserve the relative diameters at the various points. As the work approaches the finished size, measure at the different rests, after each cut.

After the first piece is finished with the diameters alike at all points, the shoe should bear alike at *A* and *B* and the sliding nut 10 should rest against the shoulder.

Leave the parts in this relation and grind the other pieces of work, adjusting screw 3 only as the shoe wears and screw 6 for the delicate adjustment for diameter. Note the effect of the adjustment upon the sparks to determine the approximate position.

When work is to size, the nut 10 and the screw 6 are intended to rest against the shoulder and stop to prevent further pressure of the shoe upon the work. The shoe and wheel will be left in the proper position for sizing duplicate pieces.

When unground work is placed on the centers and in the shoe bearings, the nut 10 and screw 6 will be forced away from the shoulder and stop, thus compressing the springs 5 and 8

Should the shoe bear unequally on *A* and *B*, tighten screw 4 to increase pressure at *A*, and screw 7 to increase pressure at *B*. Do not make the combined pressure of these springs greater than necessary, as long and slender work, although of uniform diameter, may not be straight when released from the shoe unless some allowance is made for elasticity.

**Roughing and Finishing Cuts.** In the modern grinding machine the work speed, cross-feed, and table feed are independent of each other. That is, any desired table feed, coarse or fine, may be used on work of any diameter, the work, of course, revolving at the proper speed for that particular job. The cross-feed may be set for any desired amount. Consequently the combination of work speed, table feed, and cross-feed may be used that in roughing will serve to remove the metal most quickly, and in finishing will give the kind of surface desired.

It will, of course, depend upon the size of the work, the number of pieces, the degree of accuracy required, etc., whether it will be better to rough and finish in one setting, or to rough all the pieces before finishing any. In either case it will be advisable to take two or more

light cuts when finishing. It will be advisable also to decrease the table feed to two-thirds or three-quarters of the roughing feed.

**Use of Cutting Lubricant in Grinding.** Provision is made in most grinding machines for keeping a steady flow of cutting lubricant directed on the part of the work where the wheel touches.

In the smaller types of grinding machines, cutter grinders, and toolmakers' surface grinders, etc., this feature is not provided, but in the external- and internal-cylindrical-grinding machines and larger surface-grinding machines, it is an absolute necessity. An uneven temperature of the work will cause distortion and a consequent inaccuracy. The flow of compound serves to prevent this and serves also to keep the wheel clean and free-cutting, which makes for greater production.

There are several specially prepared compounds in the market which, when mixed with water, are very satisfactory, and the grinding-machine or abrasive-wheel manufacturers are glad to recommend certain brands.

If clear water is used, it will rust the machine and the work, and to prevent this just enough sal soda is added to show a slight deposit on the finished work when dry. Many machinists add a small quantity of oil, which serves to give a better finish on the work.

### QUESTIONS ON GRINDING I

1. What do you understand by the terms *grinding* and *polishing*?
2. What do you understand by "commercial grinding"?
3. What do you understand by "efficient grinding"?
4. State at least five things necessary for an accurate job in grinding.
5. What is meant by traverse grinding? Set-wheel grinding? Infeed grinding?
6. Is form grinding infeed grinding? Explain.
7. Can you explain why understanding the construction of the machine will increase your production? Can you give an example?
8. Can you state why habits of reasonable care will increase production?
9. What does increased production mean to you?
10. Should the surface speed of a grinding wheel be more or less than a mile a minute? About how much? What do you understand by a "safe" speed?
11. How many revolutions per minute will be a safe speed for a 10-in. wheel?



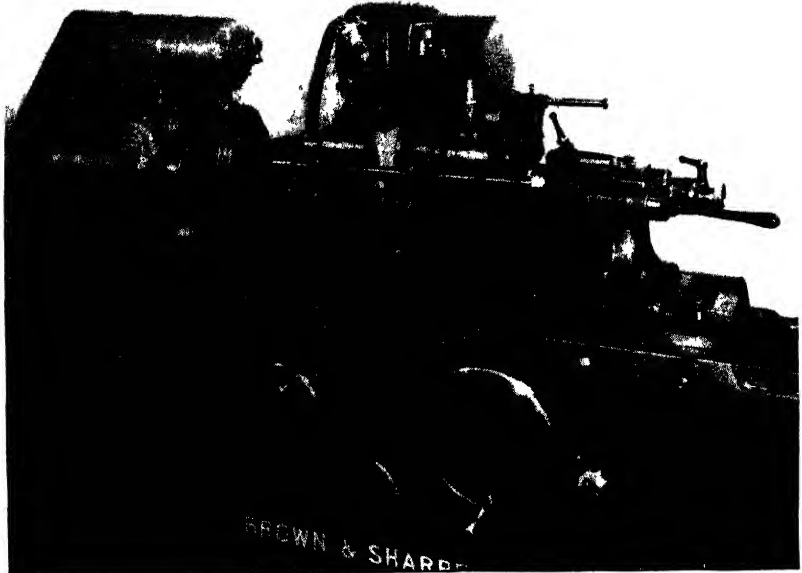
12. How do the work speeds for roughing and finishing soft steel, cast iron, and bronze in a grinding machine compare with speeds for turning these materials in a lathe?
13. Why is it that a soft wheel is used for grinding hardened steel and also for the soft materials such as bronze and copper, while a harder wheel is used on machine steel, a material of medium hardness?
14. A wheel may act harder or softer according to the work speed. How do you account for this?
15. Why are softer wheels used for larger diameters than for smaller diameters of the same material?
16. Does the same principle (as in question 15) apply in surface grinding and internal grinding? Explain.
17. What effect in grinding has the *grain* of the wheel?
18. A few years ago the machinist set the table traverse to feed anywhere from  $\frac{1}{1000}$  to  $\frac{1}{64}$  in. per revolution of the work. What is the modern practice?
19. Also it was the practice to take about half a thousandth chip. What is the modern practice in efficient grinding?
20. Occasionally it is advisable to feed the wheel in by hand, but usually it is best to use the automatic cross-feed. Explain.
21. Why is a coarse wheel used in roughing? Why is a coarse wheel satisfactory for many finishing operations?
22. What is the advantage of the combination wheel?
23. What is meant by penetration in a grinding operation?
24. On one job it may be advisable to leave  $\frac{1}{32}$  in. for grinding, on another job only about 0.005 in. How do you explain this?
25. What is the advantage of having work speed and table traverse independent of each other?
26. If you had, say, 100 pieces, easy to handle, how would you proceed to rough- and finish-grind them? Why?
27. Might it be advisable to rough and finish larger, heavier pieces in a different way? Explain.
28. If production is not up to standard quantity and quality, what would you suggest as possible causes?
29. What do you mean by a wheel being loaded? What does it indicate?
30. How do you account for a wheel's becoming glazed?
31. How are wheels wasted?
32. What is the primary reason for using cutting lubricant? State two other reasons.
33. Explain the advantage of grinding work on dead centers.

## GRINDING OPERATIONS

## A FEW SUGGESTIONS

1. Be sure the wheel is guarded.
2. Do not use a wheel that is not sound. Tap it lightly with a hammer and listen for a clear ring.
3. Remember to change the revolutions per minute of the wheel spindle if a larger or a smaller wheel is substituted.
4. Always dress a wheel after substituting it for another; running out ever so little will defeat efficient production.
5. If the wheel does not go on the spindle easily, scrape the lead bushing a little.
6. Never take a diamond tool away from the toolroom without first making sure the diamond is firmly held in the holder. You may get charged for a diamond you did not lose or you may lose a diamond someone else has loosened.
7. An abrasive wheel, like any other cutting tool, gets out of shape and dull; dress (sharpen) it occasionally.
8. See that the grinding-machine centers are smooth and clean and that the work centers are in good shape, cleaned from dirt, and well oiled.
9. Be careful to *know* that the table-feed-reverse dogs are correctly adjusted.
10. When setting up, cleaning, or oiling, it may be necessary to move the table by hand. Move the wheel out of the way first.
11. Clean the swivel table thoroughly before moving the tailstock or the headstock.
12. Don't attempt to grind when the belts slip; pay special attention to the wheel-driving belt.
13. Always keep measuring tools and gages covered when not in use.
14. When finish-grinding, if it is necessary to stop the machine for a considerable time, as for lunch or overnight, do not start to grind as soon as the machine is started. Many pieces have been spoiled in this way. Let the machine run for 5 min. to warm up.

**Cylindrical Grinding** (Fig. 14-15). The sample piece as shown in the illustration is long, cylindrical, and of two diameters—one end being smaller than the rest. The longer and larger section is to be



**Fig. 14-15.** Setup for cylindrical grinding. (*The Brown & Sharpe Manufacturing Company*)

ground. The steps in setting up the job are as follows (a Brown & Sharpe No. 2 universal grinder is used):

#### OPERATION SHEET

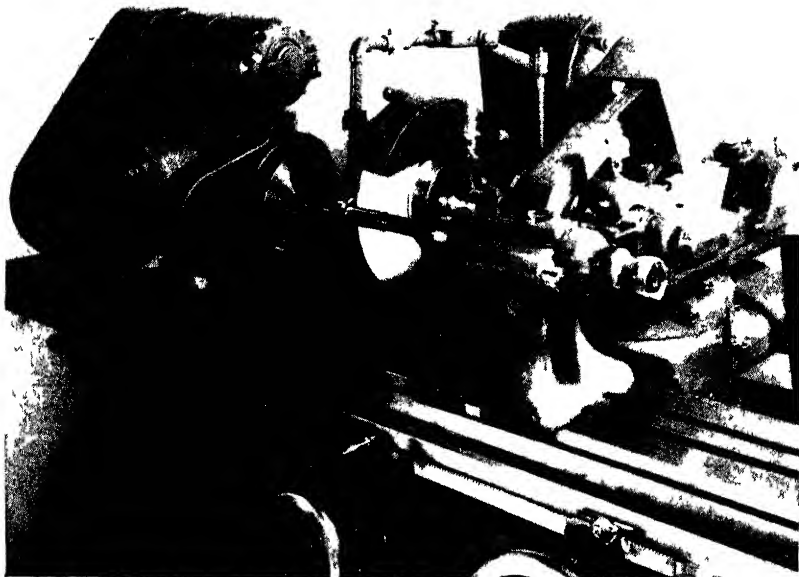
1. Set the wheel-stand platen parallel with the slide and set the bed at zero degrees so that the spindle will be parallel with the table and the bed will be at right angles to it.
2. Check the direction of the counterweight pull on the slide so that it is correct for external grinding.
3. Mount a straight wheel between the bearings. Determine what the wheel speed should be and change the spindle-driving pulley or sheave accordingly. Check the belt tension.

4. Run the wheel slide forward and back with the cross-feed hand-wheel to make sure that the wheel stand is located on the platen so that the wheel will come forward enough to grind yet go back far enough to clear the work when truing or dressing and changing pieces.
5. Set the swivel table at zero. Final adjustments for perfect parallelism are made with the swivel-table adjusting screw or knob after a trial cut has been made.
6. Arrange the headstock for dead-center grinding, using the correct pulleys for the work speed needed, and set the unit at zero degrees so that it will be parallel with the table.
7. Attach the correct driving dog to the left end of the work and, holding that end of the work on the head-stock center, slide the footstock along the table until it supports the other end of the work. The spring in the footstock should be compressed a little.
8. While still holding the work, move the footstock center with the operating lever to make sure that the center can clear the work. Clamp the footstock to the table, and adjust the tension on the spring so that the center will be held firmly in the work, but no more than is necessary.
9. Pull out the table-control lever at the edge of the table hand-wheel to disengage the power-feed mechanism. Determine the rate of table travel, change the belt on the cone pulley, and set the table motor control accordingly.
10. Hook the bronze shoes on the back rests and attach the latter to the table, letting the shoes hang clear of the work. If adjustable shoes are used, they should first be fitted to the work.
11. Adjust the coolant piping and nozzle. Attach table water guards and pan water guards.
12. Start the wheel rotating, and true with the diamond mounted on the footstock.
13. Adjust the table dogs for length of table stroke.
14. Start the work rotating, turn on the coolant, and start the table traversing. Adjust the automatic cross-feed mechanism and the back rests while grinding the first piece.
15. When the work is finished, release the pawl from the feed stop of the cross-feed mechanism and run the wheel back.
16. Then shut off the coolant, stop the table and the work and change to a new piece.

17. To grind the new piece, set the table and work in operation again. Turn on the coolant. Run the wheel in until it touches the work, and engage the pawl with the dial.

*NOTE:* During the course of the job, dress the wheel when needed, and occasionally check the diameter of the work at each back rest for consistency.

**Shoulder Grinding** (Fig. 14-16). It is often necessary that the side of a shoulder on a cylindrical piece, such as the one illustrated,



**Fig. 14-16.** Setup for shoulder grinding. (*The Brown & Sharpe Manufacturing Company*)

should be ground square with the axis of the piece. Following are the steps taken in setting up the job using a Brown & Sharpe No. 2 universal grinder:

#### OPERATION SHEET

1. Mount a flaring-cup wheel, particularly suited for this type of work, on the left end of the spindle, and arrange the entire

- wheel-stand assembly, headstock, footstock, and swivel table as if for cylindrical grinding (see previous operation).
2. Arrange for manual cross-feed and table feed.
  3. Adjust the coolant piping and nozzle.
  4. Start the wheel rotating, and true the wheel. Remove the truing fixture (if one was used) when finished.
  5. Attach table water guards and the pan water guards.
  6. Start the work rotating and turn on the coolant.
  7. Run the wheel in toward the work while moving the shoulder of the work toward the wheel until the leading corner of the wheel is in the recess between the shoulder and the cylindrical surface next to it.
  8. Then move the table to the right until the work contacts the wheel. *Do not move* the wheel forward and back while grinding, because the cup wheel generates the flat surface at the point of contact.
  9. After the shoulder has been ground, move the work to the left again while running the wheel back to clear the work.
  10. Stop the work and shut off the coolant.
  11. Change to a new piece and repeat the above steps.

### SUGGESTIONS

1. To grind the side of a shoulder square with the axis of the piece and obtain a particularly good finish, a straight full-size wheel is used, mounted between bearings. The wheel platen is turned right hand, to bring the spindle to as near 45 deg. with the work as possible, without causing interference between the wheel stand and the footstock.
2. If the side of the shoulder of the work is wider than the side of the wheel, the wheel is moved forward and back while grinding.
3. It is advisable always to grind a shoulder with the wheel pressure in the direction of the headstock, so that the spring in the footstock will not have to take the thrust.

**External Taper Grinding** (Fig. 14-17). Accurate tapers of any degree are easily ground. The sample piece shown in the illustration is a bullnose lathe center, and it is required to grind the 60-deg.



**Fig. 14-17.** Setup for external taper grinding. (*The Brown & Sharpe Manufacturing Company*)

included angle of the nose. These are the steps to follow in setting up the job using a Brown & Sharpe No. 2 universal grinder:

#### OPERATION SHEET

1. Arrange the entire wheel assembly, headstock, footstock, and swivel table as if for cylindrical grinding, except for setting the wheel-stand platen and wheel-stand slide. Since the reading on the wheel-stand slide scale is zero degrees when the slide is at right angles with the table ways, set the slide to the angle which is the complement of *half* the included angle of the taper. In this case, half of the included angle is 30 deg., and the slide is set at 90 deg. *minus* 30 deg., or 60 deg., thus bringing the slide to the same angle with the table as the taper to be ground.
2. Next turn the platen so that the spindle is as nearly parallel with the slide as possible without interference between the spindle and the footstock. The more nearly parallel the spindle and the slide are, the easier it will be to form the wheel.

3. Arrange for manual cross-feed and table feed.
4. Adjust the coolant piping and nozzle.
5. Mount the diamond in the wheel-truing fixture bolted to the table. Start the wheel rotating and true the face of the wheel parallel with the slide. Remove the fixture when finished.
6. Attach the table water guards.
7. Start the work rotating and turn on the coolant.
8. The piece is then ground by moving the wheel back and forth across the work by turning the cross-feed handwheel, while the work is moved toward the wheel by moving the table to the right.
9. When the piece is finished, run the table to the left to clear the work from the wheel.
10. Stop the work from rotating and shut off the coolant.
11. Change to a new piece and repeat the above steps from step 7 to step 10.

### **SUGGESTIONS**

1. For grinding a slight taper, the machine is set up entirely as if for cylindrical grinding, except that the swivel table is set at the required angle for the taper to be ground. The machine is operated during the course of the job just as if it were doing a cylindrical grinding job.

2. A steep taper for which the wheel-stand platen and slide must be set, and a slight taper for which the swivel table is set, can both be ground on the same piece at one setting of the machine. The slide is set at the angle which is the complement of the difference between half of the included angle of one taper and half the included angle of the other. For example, if half the included angle of the steep taper is 25 deg. and half the included angle of the slight taper is 5 deg., the difference between them is 20 deg. and the slide, therefore, would be set at  $90 - 20$ , or 70, deg.

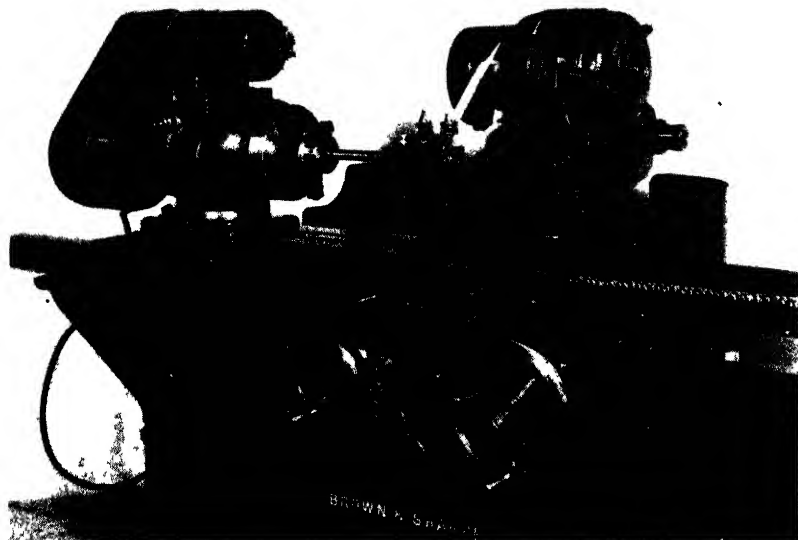
With the platen, slide, and swivel table set properly, the face of the wheel is trued for grinding the slight taper by moving the table back and forth. The side of the wheel is trued at an angle with the face for grinding the steep taper by moving the wheel slide back and forth. The diamond is held in the wheel-truing fixture for both truing.



First, the slight taper is ground, and then, without removing the piece from the centers, the steep taper is ground.

3. It is advisable always to grind a taper with the wheel pressure in the direction of the headstock, so that the spring in the footstock will not have to take the thrust.

**Internal Grinding** (Fig. 14-18). Straight and tapered holes, both open and blind, can be ground. The sample shown in the illus-



**Fig. 14-18.** Setup for internal grinding. (*The Brown & Sharpe Manufacturing Company*)

tration, however, has a straight hole running through the piece. The steps are (a Brown & Sharpe universal grinder, No. 3, is used):

#### OPERATION SHEET

1. Remove the V belts from the sheave on the wheel-spindle motor, and put the belt for the internal-grinding fixture on the flat pulley. Adjust the tension of the belt.
2. Set the wheel-stand slide at zero degrees and turn the platen completely around to bring the fixture into operating position,

- matching the guidelines on the slide to assure correct alignment of the platen and slide.
3. Change the direction of the counterweight pull on the slide so that it is correct for internal grinding.
  4. Set the swivel table at zero.
  5. Arrange the headstock for revolving spindle grinding with the four-jawed chuck, using the correct pulleys for the work speed needed.
  6. Set the headstock at zero.
  7. With the work held in the chuck, adjust the jaws so that the work will run true, using a dial test indicator to test for runout.
  8. Arrange for power-table traverse at the rate needed.
  9. Adjust the table dogs so that the work will pass partly off, but not entirely off, the wheel at the end of each stroke.
  10. Arrange for manual cross-feed.
  11. Mount the diamond in the wheel-truing fixture bolted to the table. Start the wheel rotating and true the back side of the wheel, *not* the front.
  12. Start the work rotating.
  13. Run the wheel into the hole by hand. Then engage power-table travel and feed the wheel by hand so as to grind on the back of the hole.
  14. After the hole has been trued up and a roughing cut has been taken cleaning up the hole, check for straightness of the hole. This can be done by bringing the grinding wheel into contact with the opposite side of the hole. If it is parallel and straight, the wheel will spark evenly all along the ground surface; if not, the wheel will spark on the small end of the hole, which means that an adjustment must be made.
  15. If an adjustment is needed, make it and then finish the hole. Disengage the power-table travel and run the wheel out of the work by hand. Stop the work, change to a new piece, and repeat the above steps.

### **SUGGESTIONS**

1. When changing pieces, loosen only two jaws of the chuck. This will help locate each new piece easily. It is best, however, to check each new piece for runout with the dial test indicator.

2. When dressing the wheel during the course of the job, do it between pieces.

3. Long pieces must be supported at the outer end by the center rest. If the inner end is solid, it should be supported by the headstock center and the piece should be driven by a dog laced to the faceplate. However, if the inner end has no center hole, or is not solid, it should be supported and driven by the 4-jawed chuck.

4. Tapered holes are ground by setting the wheel-stand platen and wheel-stand slide in much the same manner as for grinding external tapers.

**Face Grinding** (Fig. 14-19). A common example of face grinding is the finishing of the sides of a part shown in the illustration. The



**Fig. 14-19.** Setup for face grinding. (*The Brown & Sharpe Manufacturing Company*)

steps to be taken in setting up a machine for this type of work follows:

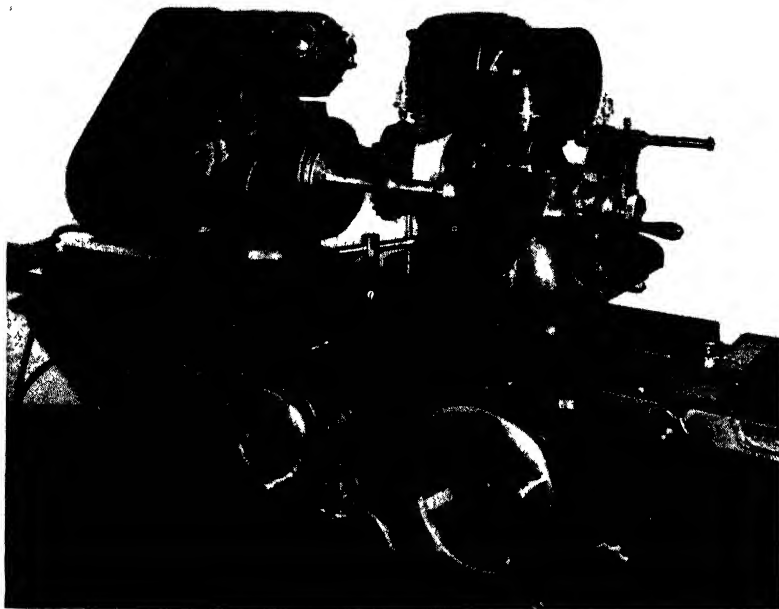
#### OPERATION SHEET

1. Arrange the entire wheel-stand assembly as if for cylindrical grinding, except for mounting a straight wheel on the left end of the spindle.
2. Set the swivel table at zero.
3. Prepare the headstock for revolving spindle grinding with the face chuck, using the correct pulleys for the work speed needed.
4. Set the headstock at right angles to the table.
5. Place a piece of work in the chuck.
6. Arrange for power-table travel at the rate needed and set the table dogs. The surface being ground should move in the opposite direction to the wheel at their point of contact.
7. Adjust the coolant piping and nozzle to the correct position and attach the pan water guards.
8. Start the wheel rotating, and true with the diamond mounted in the wheel-truing fixture bolted to the table in permanent position for the job.
9. Start the work rotating, turn on the coolant, and start the table traversing.
10. Adjust the automatic cross-feed mechanism while grinding the first piece.
11. When the piece is finished, release the pawl from the feed stop of the cross-feed mechanism and run the wheel back.
12. Shut off the coolant, stop the table and the work, and change to a new piece.
13. To grind the new piece, set the table and the work in operation again. Turn on the coolant.
14. Run the wheel in until it touches the work, and engage the pawl with the dial.

#### SUGGESTIONS

1. Saws and similar cutters often require sides that taper slightly for side clearance in sawing or cutting. Setting the headstock at slightly less than 90 deg. with the table will provide for this.

2. Face grinding the outer end of a piece with a straight shank can best be done by supporting the piece with the center rest and head-stock center, and grinding the end of the piece as if it were a shoulder. The piece would be driven and held on the center by a dog laced to the faceplate with rawhide.



**Fig. 14-20.** Setup for cutter sharpening. (*The Brown & Sharpe Manufacturing Company*)

**Cutter Sharpening** (Fig. 14-20). A cutter having straight teeth without taper is ground while supported by the centers either direct or when mounted on a mandrel. The work shown in Fig. 14-20 is a plain milling cutter mounted on a mandrel. The steps in setting up the job are:

#### OPERATION SHEET

1. Arrange the entire wheel-stand assembly as if for cylindrical grinding, making sure, however, that the wheel used is small enough to avoid interference with the tooth next to the one being ground.

2. Set the swivel table at zero.
3. With the headstock center in place, set the headstock at zero degrees.
4. Locate and adjust the footstock so that it will support the mandrel.
5. Arrange for manual table travel and cross-feed.
6. Bolt the tooth-rest bracket to the table and adjust the tooth rest.
7. True the face of the wheel so that the part of the wheel in contact with the work will be about  $\frac{1}{32}$  in. wide and the rest of the face will taper back out of contact.
8. To sharpen the first tooth, hold it down on the tooth rest and run the table back and forth, feeding the wheel in until the tooth has been sharpened. Take no cut deeper than 0.002 in., and finish off by letting the wheel spark out completely.
9. Set the stop lever of the cross-feed mechanism against the pin, and lock the lever.
10. Run the wheel back, and turn the cutter until the next tooth comes up from below and rests on the tooth rest.
11. For the second tooth and each succeeding tooth, run the wheel in until the work is touched, slide the pin forward, and sharpen. *Do not* change the position of the stop lever. In this manner, each tooth is sharpened to the same diameter.
12. *Dress the wheel only between cutters; otherwise not all teeth will be sharpened to the same diameter.*

**Surface Grinding.** This type of grinding is accomplished by fastening the work to the table of the machine and causing it to feed under the revolving grinding wheel. The principles of grinding as discussed in preceding pages apply to surface grinding as well as to any other kind of grinding.

Two types of surface-grinding machines are illustrated in Figs. 12-20 and 12-21. In the *horizontal-spindle machine* the wheel cuts only a very slight amount for each forward and return movement of the table. The table speed is 30 or more ft. per min. The cross-feed is automatic at each end of the work. In the *vertical-spindle machine*, the wheel has a considerably greater contact with the work, and the table motion is necessarily slower.

In either type of machine, the work may be fastened to the table, clamped in a chuck or special fixture, or held by means of a magnetic chuck (Fig. 14-21). Magnetic vises are made in many sizes, types, and shapes, some of which are hinged on the end of a special base and may be provided also with facilities for tipping laterally in either



Fig. 14-21. Magnetic chuck (*The Taft-Pierce Manufacturing Company*)

direction. This forms a “universal” vise. The face of the vise is made up of a number of magnet poles separated by nonmagnetic metal, and coils of insulated wire form these into electromagnets when current is applied. Rotary magnetic chucks are made for plain grinding machines, etc. Current can be supplied from any lamp socket on a direct-current circuit; *alternating current cannot be used*. Nothing but



Fig. 14-22. A demagnetizer. (*O. S. Walker and Company*)

iron or steel can be held on the vise. Do not use water except when the vise is made for it. Do not attempt to take the vise apart.

Work held on a magnetic vise becomes more or less magnetized and, while reversing the current by means of a double-pole switch serves to remove most of the magnetism, the demagnetizer (Fig 14-22) is more efficient for this purpose and is recommended. Hard

ened steel, and to a slight degree cast iron, coming into contact with the magnetic chuck, becomes permanently magnetized. On some classes of work this is found objectionable and the apparatus shown is provided for the purpose of demagnetizing the work when necessary. After the demagnetizer is first set in motion, practically all traces of magnetism are removed from the work simply by its being vibrated several times in and out of contact with the metal plates at the top. The apparatus shown in Fig. 14-22 consists essentially of a magnet suitably held and revolving under a mass of laminated sheet-iron plates, in contact with the two metal plates shown at the top.

The phenomenon of demagnetizing may be briefly explained as follows: The iron plates at the top of the apparatus represent the poles of a magnet in which the polarity is rapidly reversing. This reversal of polarity is transmitted to the work which is laid in contact. At the moment of reversal, however, there is a neutral point in which for an instant, there is no magnetism. When the work is removed out of a strong magnetic field to a weaker one (by being lifted away from the apparatus), it has moved a certain distance during the time that the magnet is neutral, and the next time it becomes charged up, being in a weaker field, it does not take so strong a charge as before. By repetition of this movement the magnetism is finally removed.

Even with the demagnetizer, total demagnetization does not occur, and this is a serious objection on certain classes of work, for example, gage work.

In such work, the thin pieces that cannot be conveniently held in a vise or otherwise clamped may be held securely by a few drops of wax here and there along the corners between the edge of the work and the table.

It should be understood that when the magnetic chuck is being used for holding small pieces, or for work with a base small in proportion to the height, an abutting piece or back stop of sufficient base and suitable thickness or height should be used to keep the work from slipping or tipping under the pressure of the cut. A piece of sheet steel—say,  $\frac{1}{16}$  by 2 by 6 in.—makes an excellent stop for the smaller pieces, and an angle plate with a base 3 or 4 in. square is very useful to support work that otherwise is likely to tip on the



magnetic chuck. Often it is best to clamp such work to the angle plate.

To hold, by the magnetism of the chuck, a piece which rests on parallels, it is necessary to have special parallels. Such parallels are made of alternate laminations of magnetic and nonmagnetic materials, for example, iron and fiber. These parallels become magnets by conduction and have about 80 per cent of the holding power of the chuck itself. Parallels, V blocks, and swiveling V blocks are made commercially. (See Fig. 14-23.)

Surface grinding calls for patience; it cannot be rushed, or heat will be generated on one side and warp the work. One- or two-thousandths chip with  $\frac{1}{16}$ -in. feed may be all a thin piece will stand

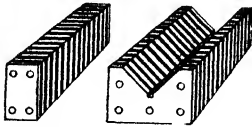


Fig. 14-23. Examples of Karnetic parallels (Kar Engineering Company)

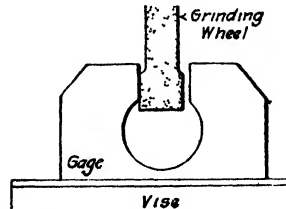


Fig. 14-24. This figure shows a wheel relieved on the sides for "face-grinding a snap gage."

unless provision is made for a flow of water on the work. The wheel should be softer than for the same material in round work, because the wheel contact is greater. When a shoulder or a face is being ground, especially in the surface grinder (see Fig. 14-24), for example, care must be taken to note that there is no end play in the machine spindle and that the bearings are well oiled.

**Centerless Grinding Machine.** It is the purpose of this text to treat the first principles of machine-tool operation and to mention only occasionally production machines and methods. The centerless grinding machine is primarily, but not essentially, a production machine. It is one of the most interesting and valuable developments in grinding practice, and it serves here to illustrate the importance of simple fundamental principles. The machine itself is not complicated, the levers are few and conveniently arranged. Almost anyone can run the centerless grinder, but *especially valuable* is the

operator of any grinding machine who understands grinding wheels, wheel speeds, and work speeds, feeds and depth of cuts in their relation to the job and to each other.

*Advantages of Centerless Grinding.* Kenneth B. Lewis,<sup>1</sup> in *The Grinding Wheel*, mentions the following advantages cited by sponsors of centerless as compared with conventional cylindrical grinding:

1. In the through-feed type it is more nearly continuous, loading being done while the previous piece is still being ground.

2. The work is rigidly supported along its whole length, including that portion directly under the grinding cut, which favors heavy reductions.

3. With no axial thrust there is no danger of springing long slender pieces.

4. A true floating condition obtains in centerless work, and the errors possible in centering are eliminated; hence less stock is needed to be left for grinding.

5. Errors in setting up and in adjusting for wheel wear are halved, because stock removal is measured on the diameter rather than on the radius.

6. Errors due to wheel wear are reduced.

7. There are few wearing surfaces in a centerless grinder, and its upkeep is low.

*Features of the Centerless Grinder.* If, in any wet tool grinder, Blount, for example, a rod *R* (Fig. 14-25) is supported by the tool rest *T* and lightly pressed against the revolving wheel *W* with a stick *S*, the rod will be ground fairly round. If, instead of the stick, a set wheel, slowly revolving, regulated the *rotation* of the rod, and, together with the support, controlled the *position* of the rod with reference to the grinding wheel, the rod would be ground almost exactly round. If, further, the regulating wheel were swiveled (tilted) a little (Fig. 14-26), it would have a tendency to "feed" the work lengthwise and thus grind the whole length of the rod as it passed between the wheels.

By the development of these ideas, the centerless grinding machine (Fig. 14-27) has been designed for grinding cylinders, tapers, shouldered pieces, spheres, and even irregular-profile surfaces, with the

<sup>1</sup> Kenneth B. Lewis, *The Grinding Wheel*, The Grinding Wheel Institute, Greendale, Mass., 1951.

highest degree of commercial-grinding accuracy and often at a considerable increase in production over other methods.

There are two primary methods of grinding the work in this machine. One is the *through-feed* method, in which the work passes axially from one side of the machine to the other, entering a rough blank and coming out a semifinished or a finished product. This is for straight cylindrical work (Fig. 14-28). In the case of taper,

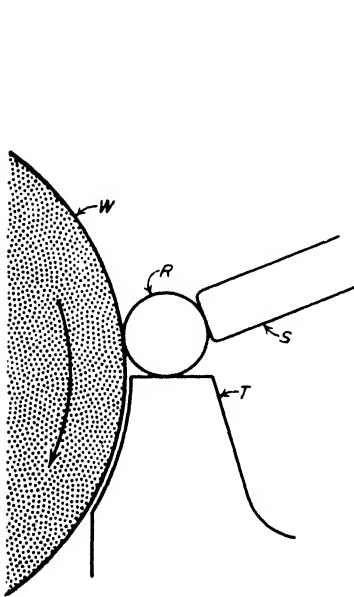


Fig. 14-25. Wet tool grinder: *R*, rod; *T*, tool rest; *W*, wheel; *S*, stick.

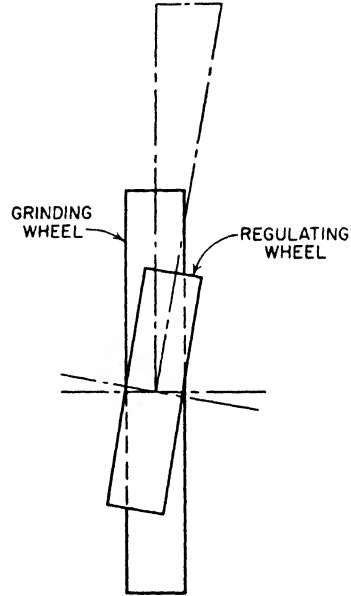
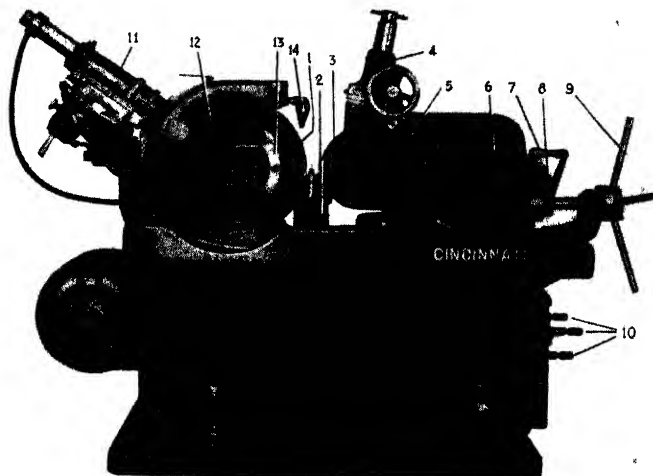


Fig. 14-26. Swiveling of regulating wheel to feed the work.

shoulder, or form work, the *infeed* method is used. This consists of entering the work either laterally or vertically into the grinding throat between the grinding and regulating wheels, steadying it in this position during the operation, and then ejecting it from the grinding throat.

The grinding wheel (1) serves solely for grinding purposes, while the regulating wheel (3) controls the speed of rotation of the work, as well as the longitudinal feeding movement. Angular adjustment of the regulating wheel makes it possible to vary the feed of the work



- 1 Grinding wheel.
2. Work rest, holds the work-support blade and four adjustable work guides.
3. Regulating wheel.
4. Screw-type truing and dressing device for the regulating wheel.
5. Regulating-wheel housing. The whole housing, including the regulating wheel (3) and the truing device (4), may be swivelled as a unit.
6. Upper slide, carries the regulating-wheel housing (5). The lower slide (not visible) carries the work rest (2).
7. Infeed lever. A down movement of 90 deg. moves the infeed unit forward 0.038 in. (The infeed unit comprises all parts (2) to (8) inclusive.)
- 8 Micrometer infeed device.
9. Pilot wheel for adjusting the housing slides (6) which carry the regulating wheel and the work rest. The work rest is, itself, adjustable on the lower slide (not visible).
10. Speed-change levers for twelve speeds of regulating wheel.
11. Hydraulic truing and dressing unit for grinding wheel.
12. Grinding-wheel guard. This and the regulating-wheel guard are easily removable to change the wheel mount and wheel.
13. Grinding-wheel mount.
14. Coolant pipe. Large coolant tank is in rear of machine.

**Fig. 14-27.** Centerless grinder. (*Cincinnati Milling Machine and Cincinnati Grinders Incorporated*)

through the machine without changing the speed of work rotation. In combination with a device which automatically supplies and ejects the work, to and from the grinding position, this makes the grinding cycle almost completely automatic.



Fig. 14-28. Close-up of a centerless grinder in operation showing coolant flowing. (Landis Tool Company)

The work rest (2) is mounted on an adjustable slide and may be correctly positioned with reference to the grinding and regulating wheels to take care of various diameters of work. It consists of a substantial cast-iron block, which holds the work-support blade and four adjustable work guides.

To accommodate various sizes of work, and for accurately sizing any given diameter, the regulating wheel has lateral adjustment: rapid with the pilot wheel (9), and a very fine hand adjustment (8) with a dial reading tenths of thousandths of an inch. In addition, a quick-acting lever (7) and positive stop are provided for infeed grinding.

The regulating wheel is carried in a housing (5) which may be swiveled about a horizontal axis and clamped in the desired position. This is to provide for different rates of longitudinal feed. There are 12 changes of speeds of the regulating wheel, obtained through sliding gears by positioning the levers (10). For through-feed grinding, the speed of the regulating wheel determines the work speed, and the inclination (tilting) of this wheel determines the rate of feed.

There is a proper ratio of grinding-wheel speed and work speed, and a proper feed, for every grinding job. The adjusting features and the speed changes of the regulating wheel provide the necessary flexibility closely to approximate ideal conditions.

Standard wheels for the machine illustrated are: grinding wheel, 20-in. diameter, 4-in. face; regulating wheel, 12-in. diameter, 4-in. face. Each wheel has its own truing and dressing device, hydraulic (11) for the grinding wheel, and screw type (4) for the regulating wheel. The careful dressing of the wheels is always important, and these devices are precision-made.

**Laps and Lapping.** Lapping is the process of giving extra smoothness and accuracy to a hardened and ground piece. The lap is a piece of comparatively soft material, such as lead, copper, brass, or gray cast iron, into which the abrasive grains are "charged," that is, imbedded in the lap, by rubbing or rolling. In general, the harder lap cuts more slowly but gives greater accuracy.

Laps are made *flat*, as a lapping plate, which is merely a flat cast-iron plate of suitable size; cylindrical for *internal* lapping (Fig. 14-29), and with a straight hole for *external* lapping (Fig. 14-30).<sup>1</sup>

There are several ways of making internal laps, three of which are shown in Fig. 14-29. The lap *a* is split practically its full length and may have one or more screws for spreading. To make the lap *b*, a tap-size hole is drilled about half the length and then a smaller hole for a short distance farther. The hole is tapped a few threads and fitted with a pointed screw. The lap is split the same as *a*. The pointed screw serves to spread the lap. A lead lap *c* is poured, somewhat over-size, around a taper mandrel which has a lengthwise groove. The lead in the groove acts as a key. After the lead is turned to size, it is split along one side.

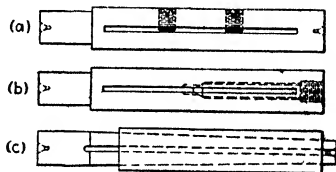


Fig. 14-29. Internal laps.

<sup>1</sup> A machine-steel disk, or "wheel," charged with diamond dust, may be used to finish very small holes or formed shapes where a grinding wheel would not hold its shape. This disk is often called a *diamond lap*. When run at about two-thirds of grinding-wheel speed, it will give an excellent finish and will hold its cutting qualities.

Commercial cylindrical gages and similar jobs, where the number will justify the setup, may be lapped on centers in a grinding machine. An aluminum disk is used in place of the grinding wheel. The aluminum is itself an abrasive, and the lapping compound consists of powdered aluminum and sperm oil. The wheel does not load. For a finish that approaches lapping, fine-grain close-structure aluminum-oxide wheels may be used.

The purpose of the lap is to give a smoother, more accurate and longer-wearing surface by removing usually from 0.00025 to 0.0005 in. from a carefully ground piece. Abrasives from No. 120 to the fine powders are used, depending upon the job. Also there are special lapping compounds made by abrasive manufacturers. Silicon-carbide abrasive cuts faster; aluminum oxide gives a better finish. Lapping is precision work. This means the use of a well-made lap, carefully charged and used with constant attention and care.

In the lapping of a bushing or a similar piece, the lap should be at least twice as long as the hole and must fill the hole with a wringing fit. The speed of the lap should be fairly slow, say, 250 r.p.m. for a 1-in. diameter. For lead laps even slower speeds are recommended.

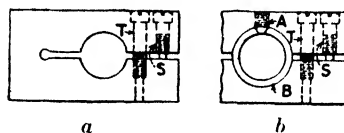


Fig. 14-30. External laps.

Hold the work by hand; if ever permissible to hold it otherwise, be careful not to squeeze it out of round. Feed the work back and forth along the lap, and when it seems a trifle free apply more abrasive. To avoid bell-mouth holes (larger on the ends), put the abrasive and the lubricant in the slot along the central part of the lap; this will serve to distribute the abrasive from the center as the work is moved back and forth. Keep the lap well charged, but without excess abrasive. Keep the wringing fit; if the lap is too free after charging, it must be expanded. One soon recognizes the proper cutting action by the *feel*. Clean and cool the work in a kerosene bath at room temperature before gaging.

What is stated above applies as well to lapping a cylindrical piece. The external lap is made as illustrated in Fig. 14-30, usually of cast iron. It should have both closing and spreading screws. This form of lap is often made with renewable split bushings of brass, copper, or cast iron.

In the figure, *a* shows a cast-iron lap with spreading screw *S* and tightening screw *T*. In *b* is shown the same type of lap provided with a renewable split bushing *B* kept from turning by the screw *A*.

When using any kind of lap, be sure that the machine parts, the chuck, etc., are protected from scattered abrasive.

A lap for flat surfaces, such as size blocks, gage parts, etc., is a seasoned and finished cast-iron plate with a flat surface—say, 6 or 8 in. square—charged with fine or “flour” abrasive and kerosene

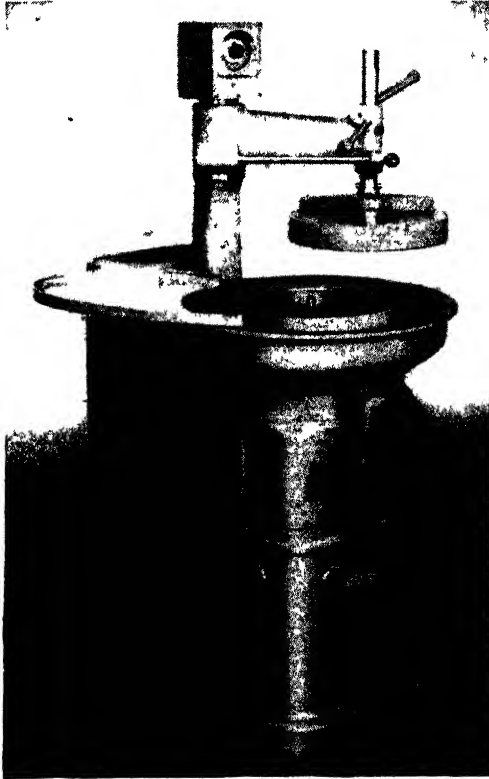


Fig. 14-31. Norton Lapping Machine. (*Norton Company*)

or an equivalent lapping compound. To ensure a flat-lapped surface, the work is given a back-and-forth and circular motion over practically the whole surface of the plate, and is occasionally allowed to twist around under the finger pressure. The plate is cleaned with kerosene as often as it becomes sticky. To give the “finishing touch” to the work, wipe the plate dry and clean, and then lap dry with



kerosene, as preferred. The clean plate will be sufficiently charged to give the finish desired.

Figure 14-31 shows a commercial lapping machine and Fig. 14-32 shows an operator lapping parts in the lapping machine.

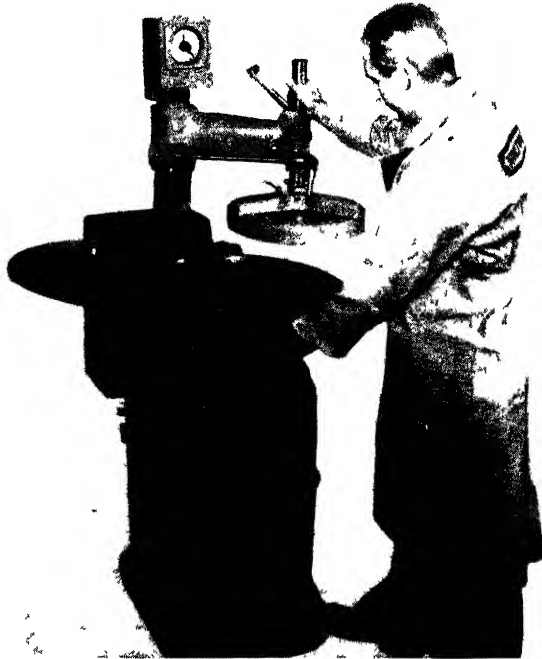


Fig. 14-32. Action view showing operator lapping parts on a Norton lapping machine. (*Norton Company*)

## QUESTIONS ON GRINDING II

1. Define grinding.
2. What is the primary function of a grinder?
3. List at least eight safety rules for the grinder.
4. Name and define the various kinds of grinding. Give an example of each.
5. Name five factors for successful grinding and explain each.
6. Explain what is meant by "arc and area of contact."
7. State just how you would mount a new wheel on a grinding machine.
8. Define dressing. Define truing. Name differences, if any.

9. Name the types and functions of the various wheel dressers.
10. What are industrial diamonds? How are they used in the machine industry?
11. Where are these industrial diamonds found?
12. What are the two common names for these diamonds?
13. Give a step-by-step procedure for truing a wheel.
14. Of what importance to a good grinding job are the following: (a) setting the job; (b) setting the wheel speed; (c) setting the work speed; (d) setting the table feed; (e) setting the depth of cut?
15. Name three causes for inaccurate work done on a grinder.
16. Name three causes of rapid wheel wear.
17. What causes "glazing" or loading of a wheel?
18. Of what use are back rests or steady rests? When are they used?
19. What is meant by a roughing cut? a finishing cut?
20. Should cutting lubricants be used in grinding? Why?
21. Give 10 valuable suggestions for good grinding practice.
22. Can you suggest why a wheel that has been running a few minutes will run more smoothly and in a slightly different position than when first started?
23. Are you able to tell a sound wheel from a cracked wheel? How?
24. Set down the operations in grinding a taper. How do these operations compare with those in grinding a cylinder?
25. What is a face chuck? How and when is it used?
26. What is a magnetic chuck? Where is it used? Why is it used?
27. Is a piece 6 in. square held more securely in a magnetic chuck than a piece 1 in. square? Why?



# *Hydraulics*

---

## CHAPTER 15

---

### **Hydraulic Power Transmission**

In modern metalworking plants, hydraulic pressure is being used to operate practically every type of machine tool. This is due largely to the simplicity of this method of applying power, to the smoothness of operation that can be attained, and to the flexibility of control.

Recognition of the merits of hydraulic operation has gradually increased since it was first put into use in the operation of machine tools. This is because hydraulic actuation offers many advantages, such as complex control; various cutting speeds which are accurately controlled and changeable during operation; rapid tool approach, with slow cutting feed; rapid return of the tool at the end of the cutting stroke; smooth, vibrationless action that is little affected by the changes in the load; cushioning effect on tools, which often results in an improvement of surface finish; and many others.

The purpose of this chapter is to discuss briefly the fundamentals of hydraulic systems and how specific machine tools make use of the principles of hydraulics, and what are the requirements demanded of the liquid (oil) used in these machine tools.

Hydraulics is not a new science, as hydraulic applications may be seen in many places. In a garage, for example, a mechanic raises the front or the rear of an automobile with a hydraulic jack; in a service station, an attendant uses the hydraulic lift to raise the car for lubrication; a dentist or a barber uses a chair which raises and lowers the person in it by a few strokes of a lever; and hydraulic presses and elevators may be seen in many places. Hydraulically operated mechanisms have been used for many years. More recently, many applications have been found in production machine tools, such as broaching, grinding, and milling machines; and the hydraulic shaper,

planer and grinding machine now have a place in the general machine shop and in toolmaking departments.

In this chapter, some machine tools will be illustrated and their hydraulic systems explained; other machine tools will just be shown. The apprentice should study the operating parts and learn their functions, so as to know them well, because he may be called on at times to repair them.

**Advantages of Hydraulic-power Transmission.** Although some of the advantages of hydraulic-power transmission have already been mentioned, some are repeated among those listed below, for the sake of emphasis.

1. The easy control of the force, that is, the rate of flow or pressure, or both, that may be applied.
2. Even, positive motion at all loads.
3. The accurate and convenient controls themselves --the valves by means of which a variety of motions such as table drive, feeds, inching, and clamping may be obtained, often in a cycle automatically.
4. The range of stepless speeds and feeds from zero to maximum, any one obtainable almost instantly without stopping the machine.
5. The cutting speeds and feeds are independent of each other and may be adjusted to meet the requirements of each.
6. Remarkably smooth, steady cutting action, no gear marks or chatter; tools last longer.
7. The cutting speed and power, in the shaper and planer, for example, reaches maximum almost instantly and remains constant during the whole stroke.
8. The rapid reversals at each end of the reciprocating stroke, of a surface grinder, for example, are *cushioned*; that is, they are especially smooth and shockless. This cushioning effect may be increased, if advisable, by the addition of a dashpot.
9. Dwell at the end of the feed may be provided to work automatically. This feature is often desirable in finish-milling to a filleted corner, spot facing, etc.
10. Direct application of the power is provided. In the planer, for example, the hydraulic cylinder is close up under the platen.
11. Lubrication of all parts is inherent in the unit.

12. The flexibility, as evidenced in the number and variety of motions— for locating, clamping, driving, feeding, etc.—that may be employed in a single machine. And in the use of the *unit idea* in construction, which permits of easily made changes at comparatively low cost when, for example, improved machining conditions might warrant a different valve or pump, or possibly an extra pump. Also in the commercial units themselves—many sizes, readily obtainable, all designed for compactness, durability, efficiency, and for convenient location and assembly with respect to the other machine units.

**Hydraulic Principles.** Hydraulics is the science that deals with the action of liquids in motion. The extensive use of hydraulic power today, in both force-multiplication and control hydraulic mechanisms, is due to the fact that liquids possess two physical properties which give them a unique advantage in the transmission of power.

First, all liquids are relatively incompressible. The slight decrease of volume that does occur on compression serves as a “shock absorber” to cushion the impact of starting and stopping. Even when liquids are subjected to pressures up to thousands of pounds per square inch, the volume change is negligible. The practical significance of this is that pressures exerted on one surface of a confined liquid are transmitted undiminished to other surfaces. Whereas the direction of thrust of a metal bar cannot be altered without the addition to the system of gears and other mechanisms, the pressure of a liquid can be piped around corners. It can actually be bent back on itself much more simply and efficiently than could the thrust of mechanical power transmissions. Figure 15-1 illustrates such a possibility. If pressure is put on piston  $P_1$  as shown in the illustration, piston  $P_2$  will bring that same pressure to bear on any object with which it is in contact. This procedure may be reversed so that the original pressure can be put on  $P_2$  and then  $P_1$  will do the same as  $P_2$  did before; that is, bring that pressure to bear on any object in contact with it.

The second property that makes confined liquids ideal for the transmission of power is their ability to multiply force. This property was discovered in the seventeenth century by a French scientist named Pascal and is known as Pascal's law. According to it, “A

pressure exerted on a confined liquid is exerted undiminished throughout all portions of the liquid."

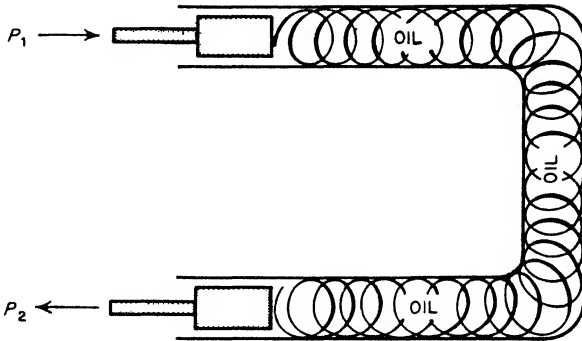


Fig. 15-1. The pressure of a column of liquid can be "piped" around corners and even bent back on itself (The Shell Oil Company)

Figure 15-2 shows a simple hydraulic press, a machine that illustrates the multiplying-force principle. In the press, the heads of two pistons press against the confined body of oil. Pascal's law states that the pressure (force per unit area) exerted by the small piston

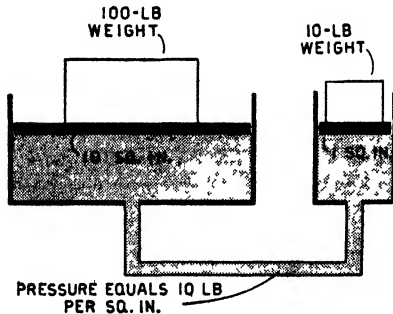


Fig. 15-2. An elementary hydraulic system (The Socony-Vacuum Oil Company)

will be the same as the pressure which the oil exerts on the larger piston. However, if the area of the large piston is 10 times greater than the area of the small piston, then the total force exerted on the large piston by the oil will be 10 times greater than the total force which the small piston exerts.

In this way, a tremendous force, not easily obtainable by other means, can be developed.

The hydraulic press performs no more work than is put into it; it merely reduces the load to convenient unit proportions, just as a pulley or a lever does.

Pascal's principle is utilized in all hydraulic systems operating and controlling machine tools. In such systems, however, the pressure

is created by a pump instead of by a small cylinder, piston, and weight. This pump pressure acts on a piston in an operating cylinder, thereby actuating the machine parts. The extent and speed of piston movement depend respectively on the volume and rate of oil flow into the working cylinder. See Fig. 15-3 for the essential parts of a hydraulic system.

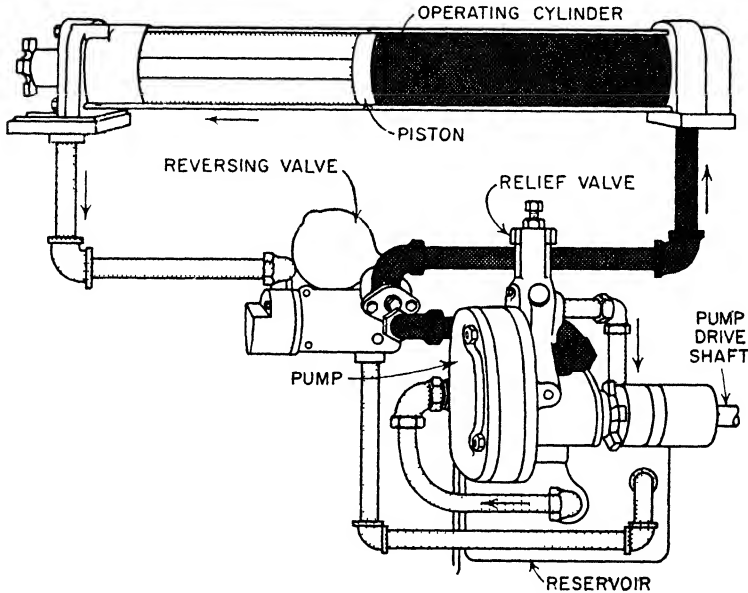


Fig. 15-3. Essential parts of a hydraulic system (*The Socony-Vacuum Oil Company*)

There are two basic methods of controlling the flow of oil in hydraulic systems. In the first method, a *constant-speed* pump discharges a constant volume of oil at constant pressure. *Gear*, or *vane*, pumps are usually used for this purpose. The flow of oil from the pump to the working cylinders is then controlled (directed, throttled, by-passed, metered, or reversed) by means of valves. This basic system is termed a *constant-volume system*.

The second method employs a constant-speed pump of such design that the rate of discharge can be varied at will from zero to maximum in either direction. Pressure varies according to the requirements of



the machine tool. In this method, the pump delivers oil directly to the working cylinders. *Plunger* pumps, in which the length of stroke can be changed, are used as a rule. The rate and direction of discharge depend upon the adjustment of the length of pump stroke and not upon additional valves. This basic system is called a *variable-volume system*.

Before describing both systems of controlling the flow of oil, the elements involved in such systems are described so that, when they are mentioned in the descriptions of the systems used in machine tools, the apprentice or mechanic will clearly understand the use and functions of the parts.

### ELEMENTS OF HYDRAULIC SYSTEMS

The most important elements of hydraulic systems are *pumps*, *valves*, and *operating cylinders*. These are the functioning parts of the hydraulic system—the parts that make the system “tick.” Each will be briefly explained and described.

**Pumps.** The pump, run at constant speed, usually by an electric motor, takes the oil from the supply reservoir and delivers it at sufficient volume and pressure to do the work required. Three types—the gear pump, the vane pump, and the plunger pump—are shown in Figs. 15-4, 15-5, and 15-7, respectively. The gear and vane types shown are constant-delivery (constant-volume) pumps, and the plunger pump is of the variable-delivery (variable-volume) type.

Many modifications of these types of pumps are built by the different makers, and each is made in a variety of sizes. The gear pump is probably the simplest kind of commercial medium-pressure constant-delivery pump. The vane type has advantages in size, weight, quiet running, and long life, and is highly efficient. The plunger type lends itself readily to variable delivery, high pressure, and smooth flow and, alone or together with a constant-delivery unit, is an important factor in many hydraulic applications.

A constant-displacement pump is, theoretically, run at a speed that will give the volume and pressure desired. Ordinarily, however, it is speeded for a somewhat greater output, and a relief valve, set at approximately the pressure needed in the machine operation, is used to take care of the extra flow, if any. To give the slower speeds of the

driven unit the oil must be throttled, and more oil will go through the relief valve. This is an objection if much changing of speeds is necessary, as it consumes power and generates heat in the oil.

The variable-displacement pump runs at a constant speed, but it may be adjusted to deliver more or less oil, so that just enough pressure is imparted to just enough oil to do the work required. Theoretically no energy is put into the oil except that which will be used in doing the work, plus the friction loss and a trifle of leakage ("slip").

The variable-displacement pump, which has its advantages for heavy duty and variable duty, is widely used. The vane-type and

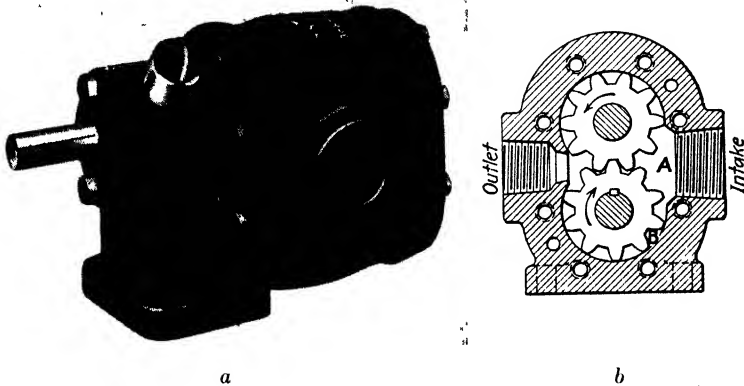


Fig. 15-4. Gear pump. (The Brown & Sharpe Manufacturing Company)

gear-type constant-displacement pumps are lower in cost, simpler in construction, and, used with modern valves, are favored for machines not requiring excessive power or wide variation in speeds.

**Gear Pump.** This type of pump, shown in Fig. 15-4, has been in use for many years for raising and circulating (pumping) various kinds of liquids. Its wide use in the hydraulic transmission of power is due to (1) the large volume at medium pressure of which it is capable; (2) its quiet running at high speed, owing to ball bearings, helical gears, etc.; (3) its simplicity, low first cost and upkeep; and (4) its small dimensions.

In action, the two gears in mesh, revolving in the direction shown in *b* (Fig. 15-4), tend to create a vacuum in the inlet chamber *A*. The atmospheric pressure in the oil reservoir forces the oil to fill this

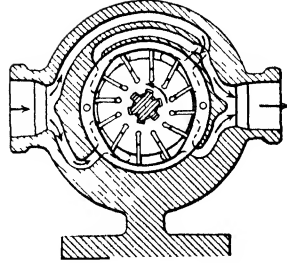
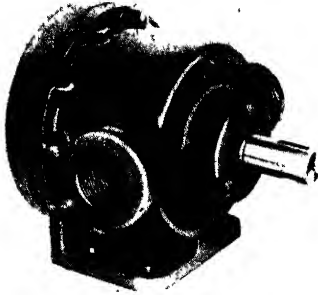


Fig. 15-5. Vane pump. (Vickers Inc.)

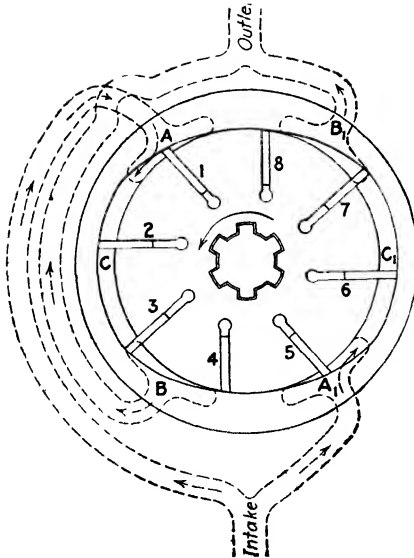


Fig. 15-6. Explanatory diagram of pump shown in Fig. 15-5. Vane 1 is about halfway across the port *A*, thus gathering a certain amount of oil. Vane 2 is forcing the oil it has gathered through the true arc enclosure *C*. Vane 3 is just starting to force the oil through outlet (pressure) port *B*. Vane 4 has finished forcing its volume of oil through port *B* and has not yet started to gather oil from *A*<sub>1</sub>. Note the balancing effect on the vanes 5, 6, 7, and 8 and ports *A*<sub>1</sub> and *B*<sub>1</sub> with vanes 1, 2, 3, and 4 and ports *A* and *B*.

suction chamber, and the oil is engaged by the teeth of the gears and confined in the spaces *B* until released and is then expelled through the outlet. The pressure given to the oil by the pump depends primarily upon the speed of the gears.

*Vane Pump.* A vane pump is illustrated in Fig. 15-5. The diagrammatic section (Fig. 15-6) illustrates the operation of this pump. The

particular type indicated is termed "hydraulically balanced" because there are two diametrically opposing pumping chambers which, being opposite each other, cancel out thrust forces imposed by the pumping action. Were these forces not balanced, they would cause heavy bearing loads while the pump is developing high operating pressures.

When the pump is in operation, the bladelike vanes slide radially inward and outward in slots while being carried around by the rotating vane carrier, or *rotor*. Power from the pump-driving motor is transmitted through the pump shaft to the rotor by a floating spline, the shaft and rotor being supported on separate bearings.

It will be noted that the radial sliding motion of the vanes is controlled by the internal camlike contour of a hardened guide ring. This ring also forms the outer circumferential wall of the oil chamber. The contour is ground to a shape which causes the vanes to move radially outward and back toward the center twice during each revolution of the rotor. Centrifugal force, plus pressure from an exhaust-port bleed, ensure that the vanes follow the cam-ring contour at all times.

The inlet and discharge ports are located in the parts which form the *sides* of the pumping chamber. They are indicated in Fig. 15-6 as *A*, *A*<sub>1</sub>, and *B*, *B*<sub>1</sub>. The functioning parts described, including the hardened guide ring, are assembled within a pump casing, this casing containing the inlet and outlet piping connections and the passages leading from these to the port openings.

It will be noted that port *A* is directly opposite *A*<sub>1</sub>, and *B* opposite *B*<sub>1</sub>. The rotor is shown in this instance revolving counterclockwise, with vane 1 about halfway across port *A*, traveling to the left. A suction is being created in the oil-chamber space between vane 2 and vane 1, and also behind vane 1, owing to the enlargement of these spaces as the rotation progresses, and oil from the supply reservoir is therefore forced into the chamber through the inlet by atmospheric pressure. Conversely, oil previously trapped ahead of vane 2, as well as that ahead of vane 3, is being forced out through exhaust port *B*. This port leads to the pressure, or outlet, connection of the pump. At the same time, the opposite pumping chamber is functioning in like manner—intake through *A*<sub>1</sub>, outlet through *B*<sub>1</sub>. Since developed pressures and vacuums are equal at all times in opposing chambers,

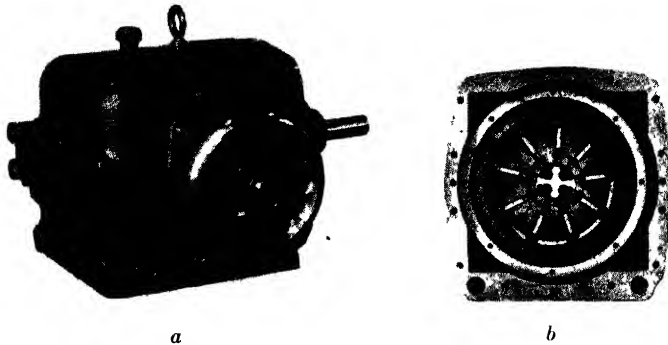
there is no crowding effect or load on the rotor bearings because the forces cancel each other.

The guide ring is so designed that radial vane movement takes place only when the vane is opposite one of the four port openings. This fact is important, in that a cantilever load caused by a higher pressure in front of a vane than behind it cannot be imposed upon a vane at any time during which it must slide in its rotor slot. However, such a cantilever condition does exist on a vane while it travels between port openings, owing to the outlet pressure being imposed on the forward side of the extended portion of the vane while a sub-atmospheric inlet pressure exists on the rear side. Therefore the shape of the guide ring between the ports is ground to a true arc of a circle having its center on the center line of the shaft, thus assuring that there will be no radial motion of the vane in the slot while the cantilever condition is existent. Summarizing, no vane load is imposed while radial motion occurs, and no radial motion takes place while the vane load is present.

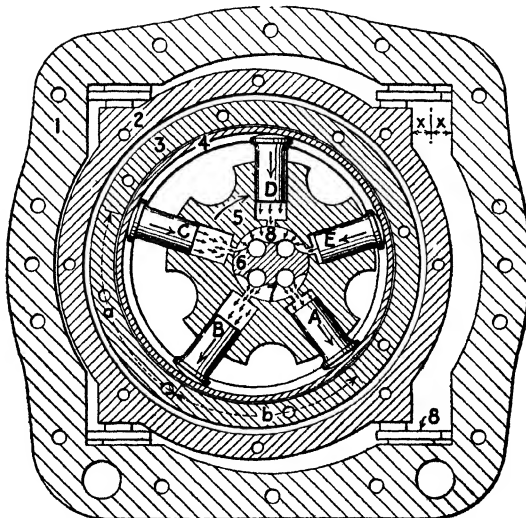
When high operating pressures are encountered, such as those for which this type of pump is designed, these points of "hydraulic balance," etc., are important in assuring quiet running and long operating life.

*Plunger Pump.* In the plunger type of pump (Fig. 15-7) the piston, or *plunger*, which fits closely in its cylinder, draws in the oil as it moves outward and expels the oil as it is pushed back. These pumps have five or more radial cylinders, each, of course, with its plunger.

Referring to Fig. 15-8, which is an explanatory diagram of the pump shown in Fig. 15-7: First, the pintle (6), which is a sort of stud shaft with oil ports and passages, is *fixed*; that is, it does not revolve, nor is its position changed at any time. Second, the cylinder barrel (5) carries in its radial cylinder bores the plunger-pistons *A, B, C, D,* and *E*. It rotates on the pintle (6) and therefore is not adjustable. Third, the plunger heads work against the reaction ring (4), which is carried by the rotor (3), and the ring and the rotor will therefore rotate with the cylinder barrel (5). Fourth, the rotor (3) and the ring (4) are carried in the adjustable slide block (2) and therefore may be adjusted off the center of rotation of the cylinder barrel by an amount equal to the distance *X*. Fifth, since the plungers are kept always against the reaction ring (4), and the rotation of the cylinder



**Fig. 15-7.** Variable-displacement pump; (b) section view of the plunger pump contained in this unit. The position of the slide block (2, Fig. 15-8) to give greater or lesser flow of oil is adjusted by turning the handwheel shown in (a). (*The Oilgear Company*)



**Fig. 15-8.** Explanatory diagram of plunger pump shown in Fig. 15-7: (1) casing; (2) adjustable slide block; (3) rotor; (4) reaction ring; (5) cylinder barrel; (6) pintle; (7) intake port; (8) pressure port. *A, B, C, D, and E* are plungers. The reaction ring (4) both pushes and pulls the plungers. (*The Oilgear Company*)

barrel (5) is out of center of the rotating reaction ring, the plungers will be given a reciprocating movement in their cylinders. (Note plunger *E* pushed *in*, and plunger *B* pulling *outward*, in their respective cylinders.) Sixth, the pintle has two lengthwise oil passages, one (7) acting as intake or suction port, and the other (8) as the outlet or pressure port. Seventh, the piston *C*, which has been pulled outward and has filled its cylinder with oil, has just started to push the oil from its cylinder into the outlet port (8), and the piston *A* is well started in drawing the oil from the suction port (7).

In action, the pump shaft is driven clockwise at constant speed. This rotation is transmitted through a suitable coupling to the cylinder barrel (5) mounted on the pintle (6). The plungers in the rotating cylinder barrel (5) are confined in the rotor (3) by the reaction ring (4), while the rotor is carried on antifriction bearings in the adjustable slide block (2), and the *eccentric relation* of the rotor and the cylinder barrel (with the rotor and ring holding the plunger heads, and the cylinder barrel containing the plungers) causes a reciprocating movement of the plungers.

When the center lines of the rotor and the cylinder barrel coincide, there is no reciprocating movement of the plungers, and no oil is pumped. As the slide block (2) with the rotor (3) and the ring (4) are moved to the left, as shown in Fig. 15-8, their centers no longer coincide and a reciprocating movement is imparted to the plungers, and those passing over the port (8) are delivering oil, while those passing over port (7) are drawing oil. Since the slide block (2) is adjustable, the amount of reciprocating movement of the plungers is variable from zero to maximum. This means that the flow of oil may be varied from zero to maximum. Also, by moving the slide block to bring the rotor to the other side of center, the flow of oil from the pump may be reversed. The port (7) then becomes the pressure port, and port (8) becomes the intake port.

The "creep" of the plunger heads on the ring, caused by the constantly changing arc distances between the plunger-heads (see *a* and *b*, Fig. 15-8) is adjusted (compensated) by a slow movement of the convex plunger head on the surface of the ring, which gives a slight rolling of the plunger in the cylinder, in one direction during half its whirl around the pintle, and in the other direction during the other half.

*Value of the Variable-displacement (-delivery) Pump.* This pump, one kind of which is shown in Fig. 15-7, is used where the rate of flow must change considerably for various speeds of the driven unit, or where, as in a milling machine, a closely measured flow for accurate feeding operations is necessary. Also, in such machines as the shaper and the planer, it is valuable not only for obtaining better cutting conditions, but it quickly accelerates the inertia load and gives full power for practically the whole length of the stroke, smoothly, steplessly, without wear and tear.

In certain installations the variable-delivery pump may be equipped with a control which will automatically keep the pressure constant, thus compensating for variable feeds, and even for the stalling of the driven unit.

In many machine-tool hydraulic applications the constant-delivery pump is used in conjunction with the variable-delivery pump in one unit or in separate units. There may be one high-pressure, low-volume variable-delivery pump to feed the machine against the cutting tool rather slowly but with considerable pressure, and the other low-pressure high-volume pump to run the table rapidly back to the beginning of the cut (rapid reverse). The rapid reverse needs plenty of oil (large volume) to push the table faster, but high pressure is not required, since there is no feeding pressure.

In Fig. 15-7 is illustrated a unit which comprises both types, plunger type (variable delivery) and gear type (constant delivery), together with the necessary control valves. Such a unit is used in the machine illustrated in Fig. 15-9.

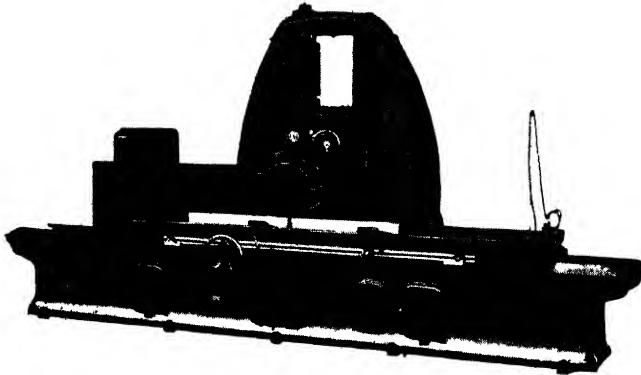
A similar unit has proved successful on production milling machines. It provides rapid traverse, either direction, and one or two adjustable feeding speeds in one direction or both directions.

In such a unit, of a size to be driven by a 5-h.p. motor, the multi-plunger variable-displacement pump delivers from 10 to 350 cu. in. per min. at a maximum pressure of 1,000 lb. per sq. in. The gear pump has a capacity of 8,000 cu. in. per min. constant volume at 300 lb. per sq. in. working pressure.

The variable-delivery pump may be used to give pressure, as against a piston in a driven unit, or as a *meter* (measure) to limit the rate of flow of the oil, as from the delivery end of a cylinder. In the meter application—in a milling machine, for example—the power



unit may contain a variable-displacement pump and two other pumps, one to supply the oil that actually pushes the piston as fast as the metering pump will allow it to go, and the other for the rapid reverse. The "back pressure" of the metering pump holds the feed remarkably steady and prevents any lunging at a light cut or at the



**Fig. 15-9.** High-duty precision surface-grinding machine. For this machine Oilgear hydraulic units (pump shown in Fig. 15-7) provides smooth positive travel of the table at speeds from 30 to 100 ft per min., quick, cushioned table reversal; inching of table; automatic feed and rapid cross traverse of grinding wheel. (*Mattison Machine Works*)

end of a cut. It is of particular value when advisable to feed *with* the direction of the cutter instead of *against* it.

**NOTE:** In the diagram (Fig. 15-21, page 528) is shown a double vane pump which, through its automatic control, serves to supply the volume and pressure needed for the cycle of rapid advance, feed, and rapid return. In this system the back pressure is regulated by the valve G.

**Valves.** The purpose of the valves is to control the flow of oil. The flow is through passages called *ports*; in through the *suction* (intake or inlet) port; out through the *pressure* (outlet) port.

Valves may be operated mechanically, electrically, or hydraulically, and for most actions may be automatic. Very sensitive valves for controlling the slightest movement ("inching"), even 0.001 in. of heavy tables, are not uncommon. Frequently two or more, and

quite often several, valves are incorporated in the same hydraulic system.

A pilot valve is operated usually by dogs on a sliding table (or by hand) to release a comparatively small amount of oil to actuate

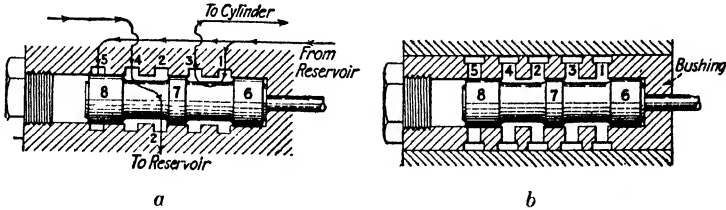


Fig. 15-10. In (a) the inside grooves, or recesses, in the valve chamber are numbered 1 to 5; the “lands” on the valve plunger are 6, 7, and 8, with the “spools” between. In (b) are shown the radial holes 1 to 5 and the connecting grooves in the bushing that, in this construction, forms the valve chamber. In either (a) or (b) the connecting oil pipe may enter the given groove at any point.

some larger valve. A relief valve may be adjusted to open at a pre-determined pressure. A check valve permits a one-way flow only. A reverse valve is for the purpose of changing the direction of the flow of oil to the driven unit. A resistance valve (foot valve) offers resistance in one direction of the flow. A control valve may cover a variety

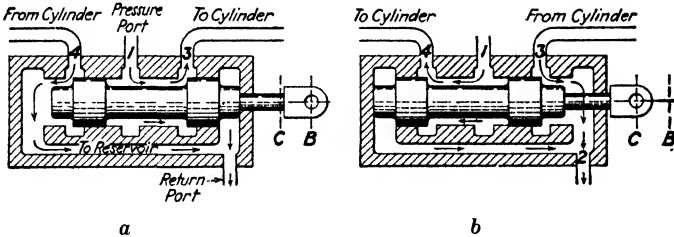


Fig. 15-11. A piston-type reverse valve.

of uses, such as starting, stopping, speed changing, and quite often the movement of other valves for various purposes.

*Piston-type Valves.* Most valves in hydraulically operated machines are of the plunger or piston type, as shown in Figs. 15-10 and 15-11. A given port is closed, that is, the oil is shut off from entering that port, by the “land” of the plunger, and the connection (open-

ing) between adjacent ports is made by the spaces or "spools" between the lands. The ports are either annular grooves (recesses) bored or cored in the surrounding valve chamber, as shown in *a*, Fig. 15-10, or radial holes drilled in from grooves turned in a surrounding bushing, as in *b*, Fig. 15-10. In order that the valve may work freely, it is necessary to have the oil pressure even (balanced), and this is the case with plunger-type valves.

The diagram (Fig. 15-11) illustrates in a simple manner how the piston valve works; arrow lines are drawn to represent the flow of oil through the pipes, ports, valve chamber, etc. Referring to *a*, the oil from the reservoir, under pressure of the pump, is forced through an opening (1), in the valve chamber to any part—top, side, or bottom, as the case may be—of the annular groove across the space (spool) to (3), thence piped to the right-hand end of the cylinder and piston of the driven unit. Meanwhile, the oil from the other side of the piston is being returned to the reservoir. It is forced by the pressure on the right side of the piston *from* the cylinder through a pipe to (4), thence to the reservoir.

Now refer to *b*, Fig. 15-11. As the valve plunger is instantly changed (say, by the action of the dog on the machine table) to the position shown in *b*, the oil flow is reversed. The oil from the reservoir is now forced through (1), then across to (4), and from there it is piped to the opposite (left-hand) end of the cylinder, and the oil on the other side of the piston is returned through the pipe to (3), across the space to (2), and thence to the reservoir.

**Control Valve.** The purpose of the pump is, of course, to give pressure to the oil; in other words, to give power to the machine. The purpose of the valves is to control the flow of oil and to apply the power when and where it may be needed. To illustrate as simply as possible how this is accomplished in a "circuit," that is, in the run of oil from the reservoir, through the pump, the valves, the driven unit, and back to the reservoir, references are made to the diagrams shown in Figs. 15-12 and 15-13.

First, get the general idea of the circuit from Fig. 15-12 (omitting the feeding mechanism), then a clear understanding of the operation of the speed-control and reverse valves (Fig. 15-13), after which it should not be difficult to understand the details of Fig. 15-13, including the feed mechanism.

The diagram in Fig. 15-12 shows the speed-control valve open (speed-control piston pulled out), permitting the exhaust through V port (9) to the reservoir. The machine is running; oil from the reservoir is being pumped in the direction of the arrows through  $R_1$  to the intake port (1) in the valve, out through (3) to the right-hand

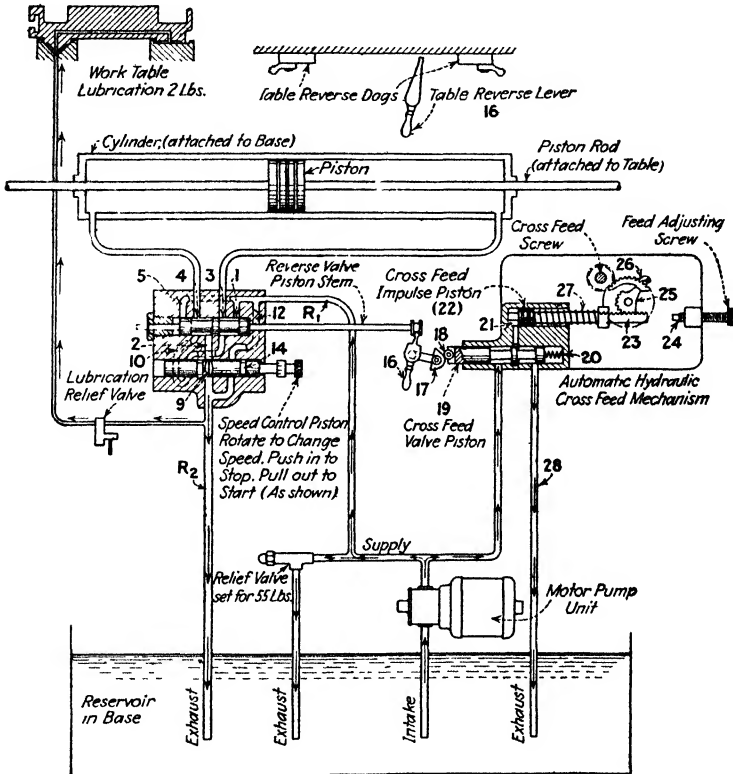
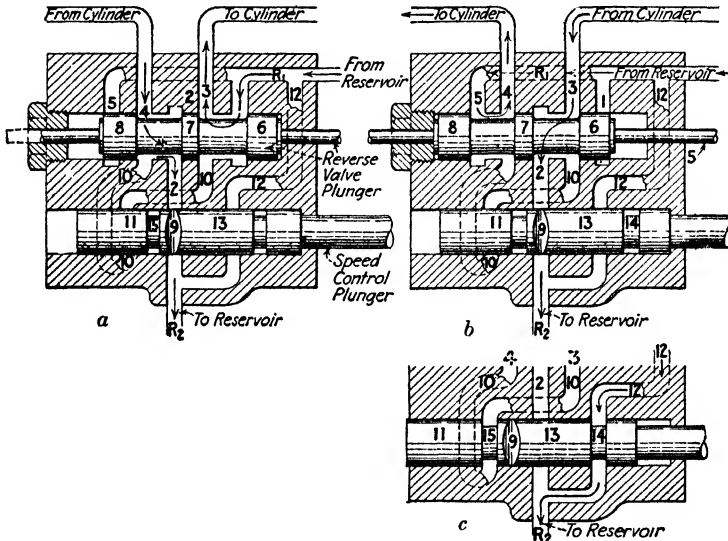


Fig. 15-12. A typical hydraulic circuit.

end of the cylinder, and forces the piston (and worktable) to the left. This pushes the oil on the left-hand side of the piston out of the cylinder and down through (4), across the spool through port (2), and on down through the V port (9) to the reservoir.

The instant the valve is changed, the flow of oil through the valve is reversed (as shown in Fig. 15-13), and the piston travels in the opposite direction.

Referring to *a* in Fig. 15-13 (which is an enlargement of the valve in Fig. 15-12), oil from the reservoir (and pump), through  $R_1$  to (1) to (3) to the cylinder, pushes the piston to the left; oil on the other side of the piston escapes from the cylinder down through (4) to (2) to (9) to  $R_2$  to the reservoir. Notice that the oil can enter (1) but cannot enter (5) because it is stopped by the land (8), also that it



**Fig. 15-13.** Control valve in Fig. 15-12 enlarged for clearness. Actually, the *speed-control plunger* is at right angles to the *reverse-valve plunger*, and the port connections, such as (10), for example, are not twisted as they appear here.

cannot enter (10) because it is stopped by the land (11), also that it cannot go through (12) because it is stopped by the land (13).

In *b* (Fig. 15-13) the valve is shown shifted to the left. This merely closes (1) and opens (5). Oil flows now through  $R_1$  to (5) to (4) to the left side of the cylinder, and at the same time the oil on the right side of the cylinder exhausts through (3) to (2) to (9) to  $R_2$  to the reservoir. Note that, as in *a*, the oil can flow only as stated; elsewhere it is shut off by the lands on the valve plunger.

Referring to the speed-control plunger, the V port (9) is simply a notch cut in the side. Rotating the plunger a slight amount serves to reduce the size of the port, and, of course, the amount of oil that can

pass through the port, and consequently the speed of the driven piston in the cylinder and therefore of the sliding worktable. When the valve is pushed way in, as in *c* (Fig. 15-13), no oil is discharged through the V port (9) and the table remains stationary, oil from the pump by-passing through the exhaust line (12) and the space (14). This is the way to stop the table, instead of shutting off (9) entirely, since it avoids forcing the oil through the relief valve.

It will be noted (*c*, Fig. 15-13) that, with the plunger pushed way in and the power traverse stopped, the space (15) in the control plunger opens the line (10), and oil may flow from either end of the cylinder through (10), making hand feed of the table possible. That is, as the table is fed back and forth by hand, the oil which fills the cylinder and the pipe line is pushed by the piston back and forth from one side of the piston to the other through the pipe line. To understand this more easily, refer first to *c* (Fig. 15-13) and note the line is open through (10) and (15); then refer to *a*, same figure, and imagine this line is open as in *c*. Then as the table is moved from right to left, the oil will flow from the cylinder through (4) to (10) through (15) through the rest of (10) and on up through (3) to the cylinder. When the stroke is reversed and the table is moved left to right, the oil will be reversed and will flow from (3) to (10) through the space (15) and up through the rest of (10) to (4), thence to the left end of the cylinder.

*A Modern Control Valve.* In Fig. 15-14 is illustrated a modern plunger-type control valve, with drilled flanges, ready to be assembled in the hydraulic system, usually integral with the pump. It is only necessary to install the pipe lines to the one or more cylinders in the system and to connect the valve stem to the control mechanism (operated mechanically by cam action, or by the ram arm, or electrically by a solenoid, or hydraulically by a pilot valve). In the illustration, the port (2) is the exhaust port; the ports (3) and (4) are for connecting to the cylinder or hydraulic motor to be actuated; and the port (1), which is opposite the ports (3) and (4) and not visible, is the intake (pressure) port.

The diagram (Fig. 15-15) is a central cross section of the valve shown in Fig. 15-14 with a four-way by-pass<sup>1</sup> style of plunger in

<sup>1</sup> In a non-by-pass form of valve, the valve is either open or closed; in the by-pass valve, one or more ports may be closed, but the plunger is constructed to allow the flow of oil through the valve.

neutral position. In this plunger the spools or openings for passing the oil are three radially milled grooves, with square-shoulder grooves at the ends. Note the small V grooves cut in the lands to provide a dashpot action when the plunger moves from one position to another.

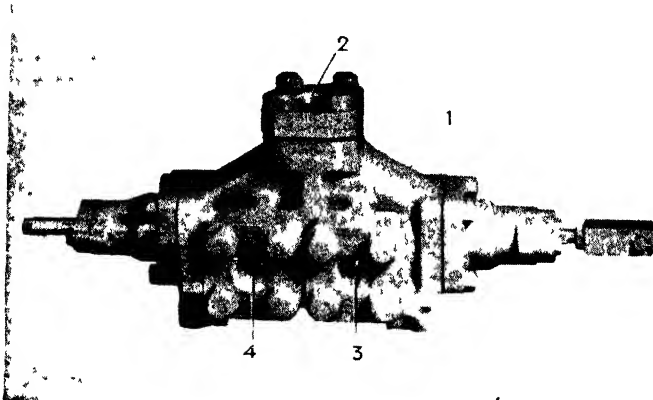


Fig. 15-14. Control valve (1) Intake port is on the other side of the valve; (2) pressure port; (3) and (4) cylinder ports. For a sectional view, see Fig. 15-15.

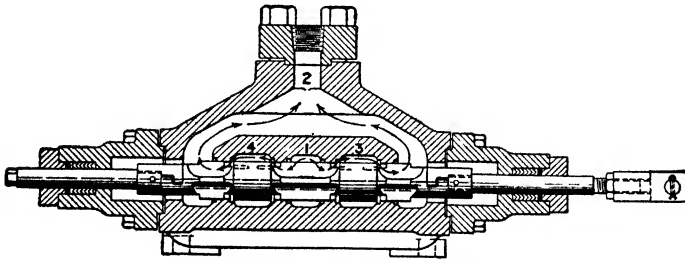


Fig. 15-15. Sectional view of a four-way by-pass valve shown in Fig. 15-14. In this view, the valve is in a neutral position and the oil is by-passing from port (1) to port (2).

To serve a particular purpose in a machine, any one of several styles of plungers may be used in a given valve chamber. Some of these styles are diagrammed in Fig. 15-17. Note that port (2) in the two-way and three-way valves is merely a drain connection to take care of the small amount of leakage (slip) past the plunger. In the

four-way valve the port (2) is used also as a return connection from the ports (3) and (4).

**Resistance (Foot) Valve.** In Fig. 15-16 is shown a section view of an adjustable resistance valve, or foot valve. It is mounted in a vertical position, and the steel ball (3) tends to seal the check by gravity. Oil entering the side connection (1) is free to flow out of the top connection (2) by merely raising the ball (3). Oil flowing in the top connection (2) is restricted by a spring pressure because the ball seats on the check and the entire plunger (5) must be moved against the spring away from its seat (6) in order to have the oil pass. The spring pressure may be adjusted by the screw (4).

In use, resistance valves may be arranged, one on each end of the hydraulic cylinder, to allow the exhaust to escape freely but offer resistance to the intake. To give an example of the use of such a valve, let it be required to clamp one piece and when it is clamped press another part on it. Two cylinders are used: one, without resistance valves, for clamping, and the other, equipped with resistance valves for pressing. The connections to the clamping cylinder, having no valve resistance, will allow the flow of oil to complete its function of holding the piece tight before the oil will force its way, against the spring-valve resistance, into the pressing cylinder. The oil, being exhausted from the other end of the pressing cylinder, flows freely through the valve on that end by merely raising the ball. The clamping cylinder operates first, both forward and return.

Foot valves are used extensively in vertical hydraulic presses to give resistance to the *exhaust* flow (see Fig. 15-20).

**Driven Units.** A rotary hydraulic motor is merely a reversed hydraulic pump. Such motors have been made and applied to lathes and other rotating-spindle machines, but the field for hydraulics in machine tools seems to be, at present, almost wholly for controlling

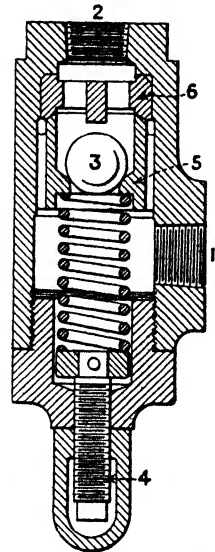
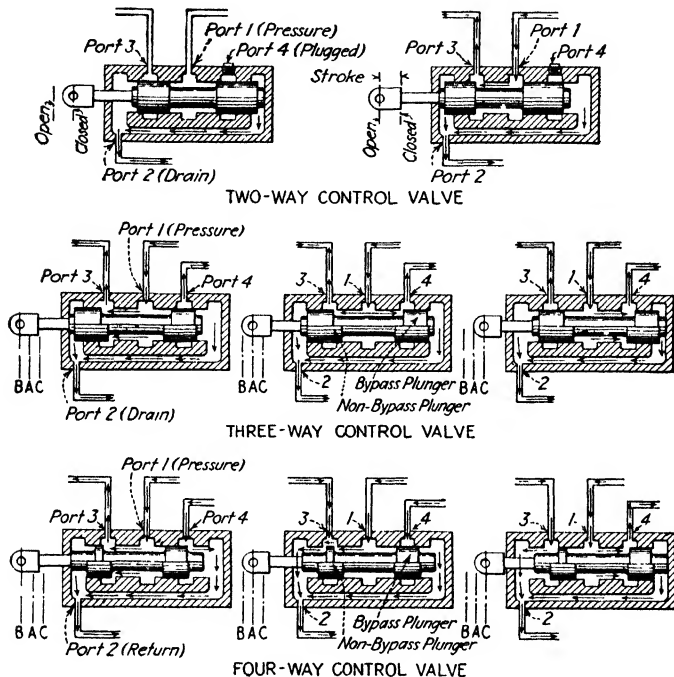


Fig. 15-16. Spring-resistance valve, or "foot valve." Oil returning through (2) must force (5) downward against the spring and thus make an opening between (5) and (6).



a reciprocating movement, as in sliding tables and kindred constructions, and for feed-unit slides.

The reciprocating hydraulic-driven unit (piston and cylinder) has two general types, one in which the piston moves back and forth in

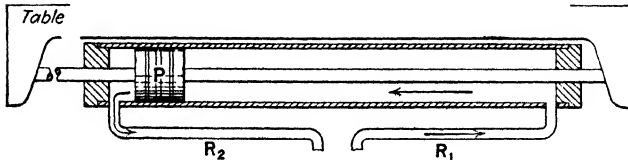


**Fig. 15-17.** Control valves. The *two-way* is merely a rapid-acting opening and closing valve. The *three-way* has no return port. It directs the oil from the pressure port to either port (3) or port (1). Such a valve may be used, for example, to deliver oil alternately to two independent four-way valves. Port (2) is merely a drain. The *four-way* is a directional control valve with the return port (2). In the diagrams of the three-way and four-way valves, the upper half of the plunger represents the by-pass type. With a by-pass valve the oil may be returned to the reservoir without going to either cylinder, thus without doing any work and therefore with little power consumption.

the cylinder and the solid piston rods are fastened to the table (Fig. 15-18), and the other having the *cylinder* fastened to the table and *hollow* piston rods to conduct the oil to the stationary piston, where it is turned back to push the cylinder (Fig. 15-19). In the latter

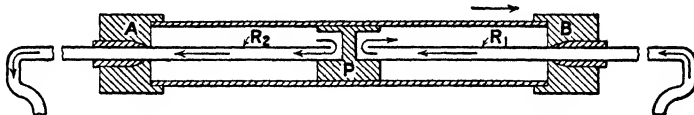
design the rods are always in tension and a smaller rod may be used.

The term *differential*, as applied to hydraulic cylinders, is the ratio of difference of active area on each side of the piston. For example,



**Fig. 15-18.** In this type of cylinder the piston rod is fastened to the table and, with the piston *P*, is moved back and forth. As shown, the oil enters through  $R_1$  and pushes the piston (and table) to the left, while oil on the other side exhausts through  $R_2$ . When the reverse valve operates, the oil from the pump enters through  $R_2$  and the oil on the other side of the cylinder exhausts through  $R_1$ .

in a machine with one piston-rod connection (a differential cylinder), the whole area of the piston toward the *blind end* (head) of the cylinder is acted upon, and the area of the *rod end* is less by the amount of the cross-sectional area of the piston rod. In a 2:1 differential cylinder the pushing area is twice the pulling area.



**Fig. 15-19.** In this type the cylinder itself is fastened to the table, and the oil flows through *hollow* piston rods. In the diagram, *A* and *B* represent the cylinder heads. To move the cylinder (and table) to the right, as shown, the oil is pumped through the hollow rod  $R_1$  in the direction of the arrow and exerts pressure against *B*. Since the piston *B* and the hollow piston rods are stationary, and the table is moving toward the right, the oil in the left end of the cylinder is being forced through the hollow piston rod  $R_2$  to the reservoir. When the reverse valve operates, the flow of oil is reversed and the table moves in the opposite direction.

The cylinders illustrated in Figs. 15-18 and 15-19 are nondifferential, to give equal pressures for reciprocating table movements of a surface-grinding machine, for example. The cylinders for shapers, planers, and presses are differential; the push needed may be two or three times that needed for the pull (see Fig. 15-20, also Fig. 15-21).

**Cross-feed Mechanism.** Referring to Fig. 15-12, page 519, it will be observed that at each reversal of the table the reverse lever (16) operates a cam (17), which works against a roller (18) in the end of the cross-feed valve plunger (19). This action pushes the valve plunger against a small spring (20), which instantly forces it back again; during this time, however, the valve has been opened and oil has been admitted to the valve chamber (21) in front of the cross-feed impulse piston (22). This pressure of oil serves to push the piston (22) and the rack (23) until stopped by the feed-adjusting screw (24). The movement of the rack is communicated to the quadrant-pawl carrier (25) and to the pawl and ratchet (26), thence to the cross-feed screw. The amount of the movement (feed) is determined by the position of the feed-adjusting screw (24).

It may be observed further that the return spring (27) of the impulse piston (22) forces the oil from the valve chamber (21) across the space or "spool" on the piston (19) and out through the exhaust (28).

**A 35-ton Hydraulic Press.** Figure 15-20 shows the installation of a hydraulic cylinder, pump, four-way control valve, resistance valve, pipe connections, pressure gage, etc.; also the control rod and the stroke-adjusting collars that serve to move the control-valve plunger.

The control valve is bracketed to the side frame of the press and is operated by means of the control-rod mechanism. To start the ram moving downward, the hand lever (6) is pulled toward the operator (or the foot pedal (8) depressed), which raises the control rod (2) and the plunger in the control valve, thereby directing the flow of oil to the top of the cylinder. The detent (1) holds the control rod and the valve plunger in this position until the end of the ram arm (5) strikes the lower stroke-adjusting collar (7), thereby moving the control rod and the valve plunger downward, which serves to direct the pressure flow of oil to the bottom end of the cylinder and to reverse the ram movement. As the ram moves upward, the end of the ram arm (5) slightly compresses the spring (4) below the upper stroke-adjusting collar (3), and moves the plunger of the control valve up to the neutral, or by-pass, position. With the valve plunger in this position, the full volume of oil from the pump is by-passed

through the control valve and returned to the pump reservoir, and the ram stops.

The resistance valve (see Fig. 15-16) is used to restrict the oil in the bottom end of the cylinder sufficiently to prevent the piston, ram, and ram arm from dropping when the control valve is in the neutral, by-pass, position.

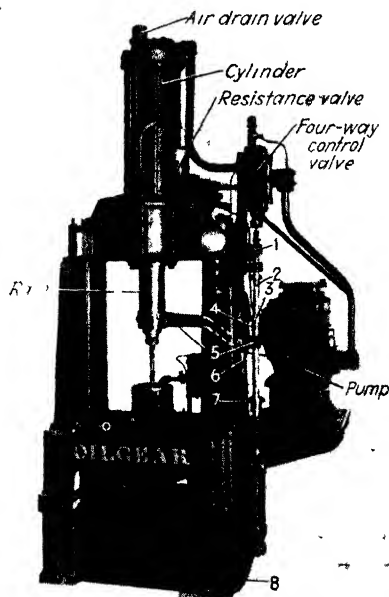
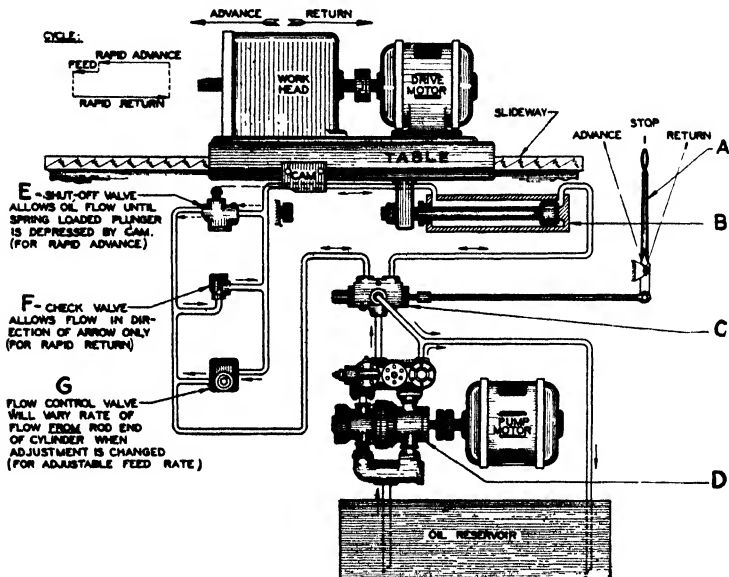


Fig. 15-20. A 35-ton hydraulic press.

**Rapid-traverse and Feed Circuit.** A common operating requirement of a hydraulic control system on machine tools, such as drills, boring machines, and milling machines, is of the rapid-traverse and feed classification. The work on a milling-machine table, for example, must be advanced nearly to the cutter at a relatively rapid rate in order to save time, then automatically slowed down to the proper feed rate before cutting begins to take place. The feed rate should be readily variable, to accommodate various tool-cutting conditions. At the finish of the feed portion of the cycle it is neces-

sary to reverse the movement of the worktable, and this may be done by hand, as shown in the table feed circuit illustrated in Fig. 15-21, or it may be accomplished by automatic means as is usually done in high-production shops. A spring "load-and-fire" latch mechanism<sup>1</sup> is



- A. Manual control lever. Automatic control may be obtained by use of pilot-operated or latch-type four-way valves.
- B. Cylinder.
- C. Directional-control four-way

valve, reverses flow of oil to cylinder, or, when at mid-point, directs pump flow of oil to reservoir.

- D. Double pump and automatic control of pressure and volume.

Fig. 15-21. Basic rapid-traverse and feed circuit.

often used for quick reversal. Another and more common method of obtaining automatic reverse is the use of a pilot valve to operate the four-way valve. Both of these methods are employed with the aid of a cam or dog on the machine table. The cam is adjustable and

<sup>1</sup> In a latch-and-fire or load-and-fire mechanism, the valve is latched against spring pressure by the operator when the cycle is started, and motion in one direction continues until a trip dog on the moving member unlatches, or "fires," the spring-loaded valve plunger. Automatic reversal of the moving member is thus accomplished.

causes the reversal to take place at any given point of the carriage advance during each cycle. The return to the starting position after reversal is at a high rate, to keep the cycle time as short as possible. An automatic stop is usually provided.

The basic schematic diagram in Fig. 15-21 shows the pump *D* supplying oil under pressure to the reversing valve *C*. The action of this reversing four-way valve has been described. In the piping connection leading between the four-way valve and the *rod end* of the cylinder are shown three other valve units having certain functions to perform. One unit is a plunger-operated shut-off valve *E*, which is closed when the plunger is depressed by the cam on the table and opened by an internal spring when the cam is withdrawn. A check valve *F* is also indicated, its function being to allow free flow in one direction at all times, regardless of the position of the shut-off valve. The flow-control valve *G* consists of a variable orifice that may be easily adjusted, and it should be of the type which will meter the desired amount of oil, regardless of a fluctuation in the pressure imposed upon it.

During the interval between cycles the operating lever is in its central, or "stop," position. The four-way valve plunger is then causing the entire discharge from the pump to be directed back to the reservoir through the piping connection shown leading directly from the valve to the reservoir.

Having set the work in the machine, the operator causes the table to "rapid advance" by moving the lever to the "advance" position. Oil from the pump is then directed to the head or blind end of the cylinder, and the oil surrounding the piston rod in the rod end of the cylinder is discharged freely through the open shut-off valve *E* and the four-way valve *C* to the reservoir. The table will thus advance at a rate determined by the maximum pump volume until the plunger of the shut-off valve *E* is depressed by the cam. After this valve is closed, the oil being exhausted from the rod end of the cylinder must escape through the flow-control valve *G* while the piston advances between opposing pressures. The rate of escape (the "metering out") is determined by the size of the orifice opening in *G*, and the rate of movement of the table during the feed is thereby controlled. Owing to the opposing pressure condition imposed on the piston by the metering-out action, a smoother feed is obtained.

The reverse of the table movement is caused by throwing the control lever to the "return" position. The oil flow through the four-way valve *C* is immediately reversed and oil under pressure is fed to the rod end of the cylinder after being circulated through the check valve *F*. During reversal both the shut-off valve *E* and the flow-control valve *G* are ineffective, and a rapid return rate is thus maintained over the entire return distance. Oil from the head end of the cylinder meanwhile escapes freely to the reservoir. When moved to the "stop" position, the four-way valve again removes pressure from both cylinder connections and allows the pump to circulate oil freely without power loss.

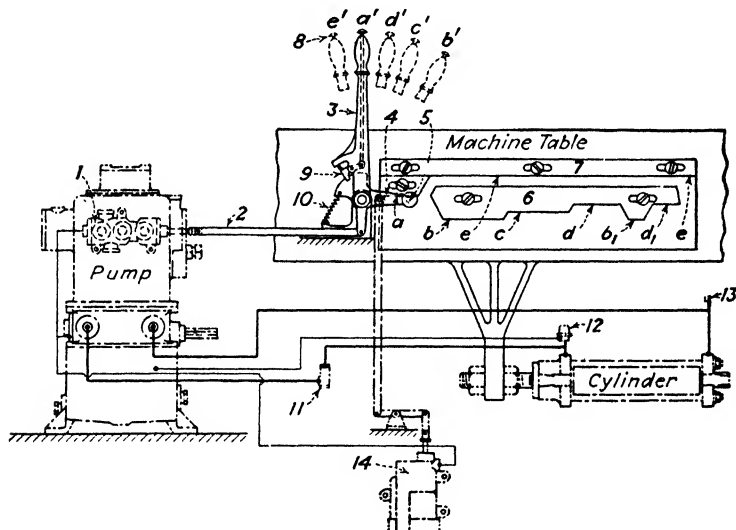
Refer to *D* and it will be noted that the assembly is made up of three units: the intake manifold; the double pump—the smaller-volume high-pressure pump at the left, and the larger-volume low-pressure at the right; and three adjustable valves—relief valve at the left, check valve in center, and unloading valve at the right. (The unloading valve is sometimes called an *automatic by-pass* valve.)

Assume, for example in a machine-tool circuit, that the relief-valve adjustment is set for 750 lb. per sq. in. and the unloading valve for 300 lb. per sq. in.

When the rapid traverse is taking place, in either direction, there is comparatively little resistance to the table movement, since there is no feeding pressure. At this time the resistance to the piston movement is below the unloading-valve adjustment (300 lb. per sq. in. in assumed case) and the circuit is open for the combined flow of oil from both the large- and the small-volume pumps. Thus: *large* volume at *low* pressure for rapid traverse.

When, however, a machine-tool cycle begins its feeding action (or when a press builds up pressure at the end of its closing stroke), the pressure in the system will build up to the relief-valve setting, which must be appreciably above the unloading-valve setting (750 lb. per sq. in. in assumed case). In the case of the machine-tool circuit, this pressure build-up is due to imposing a restriction in the metering-out end of the feed cylinder (valve *G* in Fig. 15-21). Inasmuch as the pressure builds up to the relief-valve setting, and this is above the setting of the unloading valve, the latter will be held wide open against the spring pressure and will allow the entire volume from

the larger volume pump to be unloaded or returned to the reservoir. That is, the larger pump during this period merely circulates oil, and no appreciable amount of power is required to drive it. At this time only the volume of the high-pressure pump is used—smaller volume



**Fig. 15-22.** Cam control mechanism and oil circuit. Oilgear pump, valve, cylinder, etc. (1) Six-way control valve, may be mounted on side of pump case, on frame or any nonmoving part of machine; (2) valve stem connection to hand-control lever (3) and cam-roller arm (4); (5) cam-roller spindle, has ball bearings, and when in action follows the cam outlines *a, b, c*, etc. on camplates (6) and (7); (8) pushbutton for lifting latch (9) out of the notch in cam-roller (4) and thus releasing (3) and (2) from (4). This permits of operating the valve independently of the cam to stop or reverse the worktable at any point in case of emergency. (10) Tension spring between stationary bracket and cam-roller arm (4); (11) foot valve; (12) automatic air-drain valve; (13) air-drain petcock; (14) dashpot may be installed if a dwell at each end of feed is desired.

The letters *a, b, c*, etc., indicate the cam surfaces, and *a', b', c'*, etc., the corresponding positions of the control lever (3): *a*, neutral; *b*, rapid-traverse forward; *c*, fast feed; *d*, slow feed; *b<sub>1</sub>*, same as *b*; *d<sub>1</sub>*, same as *d*; *e*, rapid-traverse reverse to starting point and stop. (After diagram from *The Oilgear Company*)

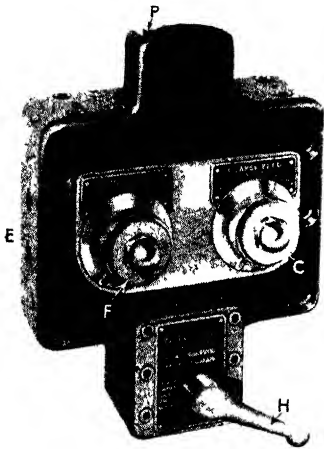
at *high* pressure for feeding. The check valve prevents loss from the high-pressure pump delivery.

Because the small-volume pump is selected as to size so that it will be slightly more than adequate to take care of the maximum feed



rate of the given machine, a very small amount of oil will be discharged over the relief valve during the feed portion of the cycle, and returned, with that from the large pump, to the reservoir. Meanwhile, the relief valve maintains the feed pressure at the given setting.

**Automatic Control.** The various manufacturers provide commercial units of pumps, valves, and control devices for performing operation cycles when actuated manually or automatically. In fact,



**Fig. 15-23.** Control panel *E*, adjustment for fine-feed series; *C*, adjustment for coarse-feed series; *H*, hand control; *P*, plunger for cam control. (*Vickers Incorporated*)

several valves may be incorporated in one unit and controlled automatically, and in some systems the volume of the variable-displacement pump is automatically changed to suit the requirements.

In semiautomatic or full-automatic operation of the modern hydraulic machine tool, employing the rapid-traverse and feed circuit, a control mechanism operated by adjustable camplates is used. By this means the plunger or plungers of the control valve are moved to select the high-pressure and low-pressure volumes in the right direction at exactly the right time in the prescribed cycle of operations for which the machine is set. Such a mechanism is indicated in the diagram Fig. 15-22. The control-valve unit (1) in this case is integral with the pump.

Many commercial applications use what is known as the *hydraulic control-panel unit*. Such a panel may combine the four-way valve, check valve, shut-off valve, flow-control valve, and auxiliary automatic-reversing and stop valves into one integral assembly. This eliminates nearly all piping and simplifies the installation. The panel illustrated in Fig. 15-23 is of this type and includes two flow-control valves, one for fine feeds and the other for the coarser feeds. As may

be noted in the illustration, the control may be operated manually by the handle *H*, or automatically by cams on the machine table depressing the plunger *P*, or electrically by means of solenoids mounted behind the panel.

**Hydraulic Oil Requirements.** Since the average hydraulic system is a more or less complex assembly of operating cylinders, valves, cams, stops, etc., and since most of these parts are operated by the hydraulic pressure developed by pumps, a sluggish or contaminated oil can interfere with their proper functioning and seriously impair the efficient operation of the machine. Maximum economical production, therefore, implies the use of a fluid medium that will act uniformly, promptly, and with undiminished effectiveness at all times. A properly selected hydraulic oil must have: (1) *exceptional chemical stability*, to resist oxidation and thus the formation of sludge or gummy deposits; (2) *maximum demulsibility*, to separate readily from water, and thus to minimize the formation of emulsions; (3) *adequate film strength*, to minimize the wear of pumps, valves, cylinders, pistons, etc., and in some machines, to prevent chatter of tables and sticking of slides; and (4) *proper viscosity and minimum change of viscosity*, to minimize leakage, and at the same time assure ready flow and prompt response to all controls, and to assure uniformly high production during the warming-up periods.

*Chemical Stability.* Oils differ widely in their chemical composition and, therefore, in their chemical stability. In a hydraulic system, constant circulation and churning in the presence of oxygen tend to produce chemical changes in the oil. Oils that cannot resist this tendency thicken and become sluggish in service. Sluggish oils retard the operating sequence and slow down production. Eventually, sludge or gummy deposits form and interfere with the reliable action of the machine tool. Therefore, an oil that resists chemical change and retains its original characteristics longer will render the most satisfactory service.

*Demulsibility.* Moisture is often present in the hydraulic system of a machine tool. This moisture may result from leakage of cutting fluid into the system or may result from condensation of the moisture in the atmosphere as air surges in and out of the reservoir breather pipe. Of course, every effort should be made to seal out cutting fluid and to eliminate this contamination.

When water mixes intimately with oil, emulsions are formed. As a result of local operating conditions, these may be of a thin, slimy nature; of a sticky, pasty consistency; or in the form of heavy, gummy deposits. Such emulsions may interfere with the proper functioning of valves and other delicately adjusted parts.

The resistance of an oil to emulsification depends upon its ability to separate quickly from moisture in order that water which enters the system shall settle to the bottom of the reservoir and not be circulated with the oil. To maintain quick separation in service, the oil must be able to resist oxidation. In other words, it must be chemically stable, so that it does not change under operating conditions.

*Film Strength.* Hydraulic oils not only serve as the means for transmitting pressure, but also act as lubricants for the moving parts of pumps, cylinders, valves, etc., and sometimes, of ways. Pressures between some of these moving parts may be extremely high. In order to prevent excessive wear, particularly where fluid pressures are high, hydraulic oils must be capable of providing strong lubricating films that resist the pressures and wiping action between moving parts at whatever operating temperatures may be met. Since a lubricating-oil film under these conditions is only microscopic in thickness, it must possess unusual film strength.

The lack of adequate film strength results in excessive wear and unnecessary power consumption. Wear inside a machine increases internal clearances and therefore internal leakage, while wear at glands and stuffing boxes increases external leakage. Both reduce the over-all efficiency of the machine. Moreover, when wear occurs, the metallic contact between the moving parts develops excessive frictional heat, which increases the oil temperature and thins the oil.

Hydraulic oils must possess the necessary film strength to resist the severe wiping action that occurs between some of the moving parts. The development of such oils is the result of many years of research made under working conditions similar to those of the machines themselves.

*Viscosity.* In all hydraulic pumps there is always more or less internal leakage, frequently referred to as *slippage*. Although this leakage does not involve actual loss of oil from the system, it does lower the capacity of the pump and increase oil temperature. In

variable-stroke piston pumps, moderate slippage can be compensated for by lengthening the strokes of the pistons.

With a gear or a vane pump, in which a by-pass relief valve controls discharge pressure, the volume of oil discharged is always greater than the demands of the working cylinders, and the excess flows through the relief valve back to the reservoir. Moderate slippage in the pump merely reduces the flow of oil lost through the relief valve. It does not change the pressure against which the pump operates or require that the speed of the pump be increased. Slippage does increase the temperature of the oil at the pump.

In order to minimize slippage and maintain maximum pump capacity with minimum power consumption and low oil temperature, it is most important to use an oil of viscosity (resistance to leakage) which is suited to the particular design of the pump.

Viscosity, however, must be considered also from the standpoint of the ready flow of the oil through the system, and the prompt response of valves and other parts. Light-bodied oils assure ready flow and quick response, but their use may result in excessive internal leakage and high power consumption. Heavier-bodied oils offer a higher resistance to leakage but they are sluggish and, therefore, require more power for circulation through the pipes, valves, and openings.

Since the choice of viscosity is influenced principally by the design of the pump and, to some extent, by the nature of the system, it is always wise to consult the instructions issued by the various manufacturers of hydraulic-machine tools, who specify the most suitable oil viscosity for their particular pump or pumps.

### SOME MODERN HYDRAULIC-MACHINE TOOLS

The constant-volume hydraulic system is found in machines where the oil pressure is not high (usually not over a few hundred pounds per square inch), where the pump delivers a constant volume of oil, where variation of rate of oil feed to machine cylinders is small, where comparatively light-weight machine parts are accelerated *and decelerated*, and where the machine cost is a consideration.

The variable-volume system is found where control of the principal motions is close, where the pump delivers a variable and metered

volume of oil, where the variation of oil flow is great, where oil pressure is high (often several thousand pounds per square inch), or where heavy, massive machine parts and heavy pieces of work are to be accelerated or decelerated without shock.

Many machines include both systems. The systems may be completely separated, to operate different parts of the same machine. They may be combined into a single system, to assume alternate

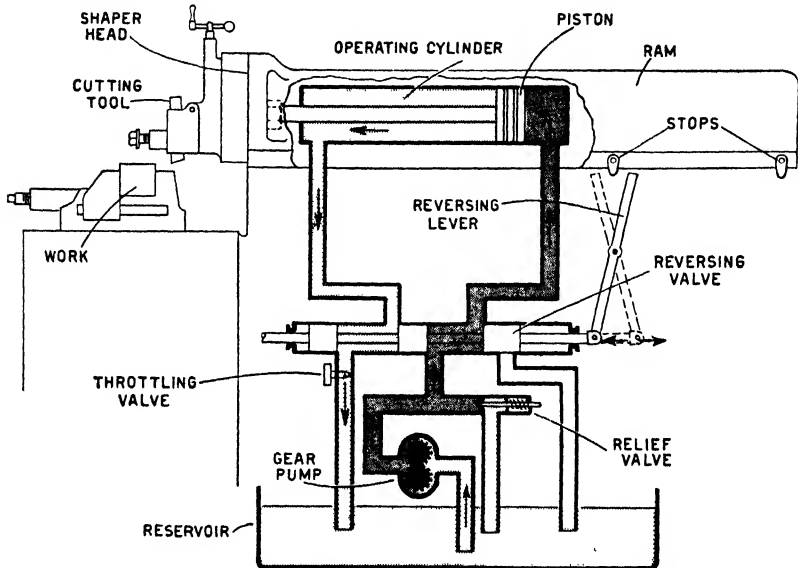


Fig. 15-24. Principal parts of a constant-volume hydraulic circuit of a shaper. (The Socony-Vacuum Oil Company)

control during certain portions of the operating cycle; or they may be combined to work simultaneously with each other.

Examples of each type of hydraulic system will be explained in the section that follows.

**Constant-volume System.** *The Shaper* (Fig. 15-24). A brief explanation of just how this system operates in the shaper follows.

Moderate oil pressure is developed by a constant-discharge, gear pump and is transmitted through piping and a reversing valve to an operating cylinder, where it acts against a piston and moves the shaper ram forward on its cutting stroke. Oil in the opposite end of

the cylinder is expelled by the same movement of the piston and returns to the reservoir. At the end of the cutting stroke, a stop engages a reversing lever, which throws the reversing valve and thus directs the oil under pressure to the other end of the operating cylinder, causing the piston and the shaper ram to return. At the end of the return stroke, a second stop engages the reversing lever, which again throws the reversing valve and starts the shaper ram

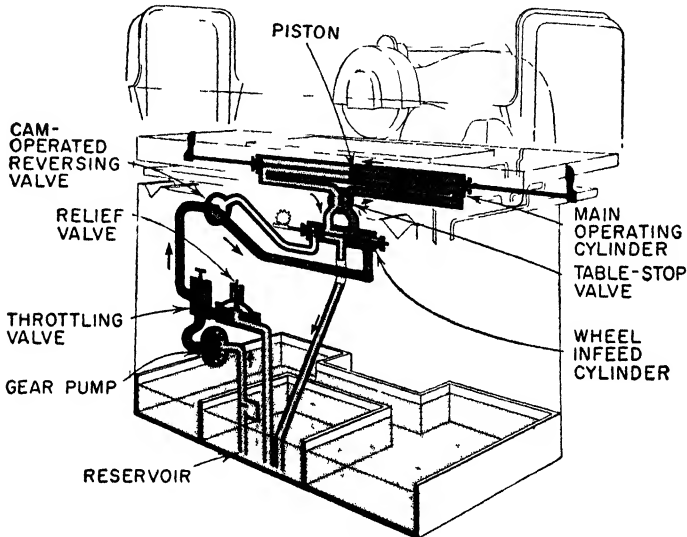


Fig. 15-25. Constant-volume hydraulic system of a surface grinder. (*The Socony-Vacuum Oil Company*)

on another cutting stroke. The stroke of the shaper may be controlled by adjusting the position of the stops. Since the discharge rate of the pump is constant, the rate of travel of the shaper ram on the return stroke will be more rapid than on the cutting stroke, owing to the presence of the piston rod in the head end of the cylinder. Cutting speed on the cutting stroke is controlled by a throttling valve in the discharge from the head end of the operating cylinder. By partly closing this valve and thus restricting the flow of oil, the cutting speed is decreased without affecting the speed of the ram on the return stroke. When the flow of oil is thus throttled, a relief

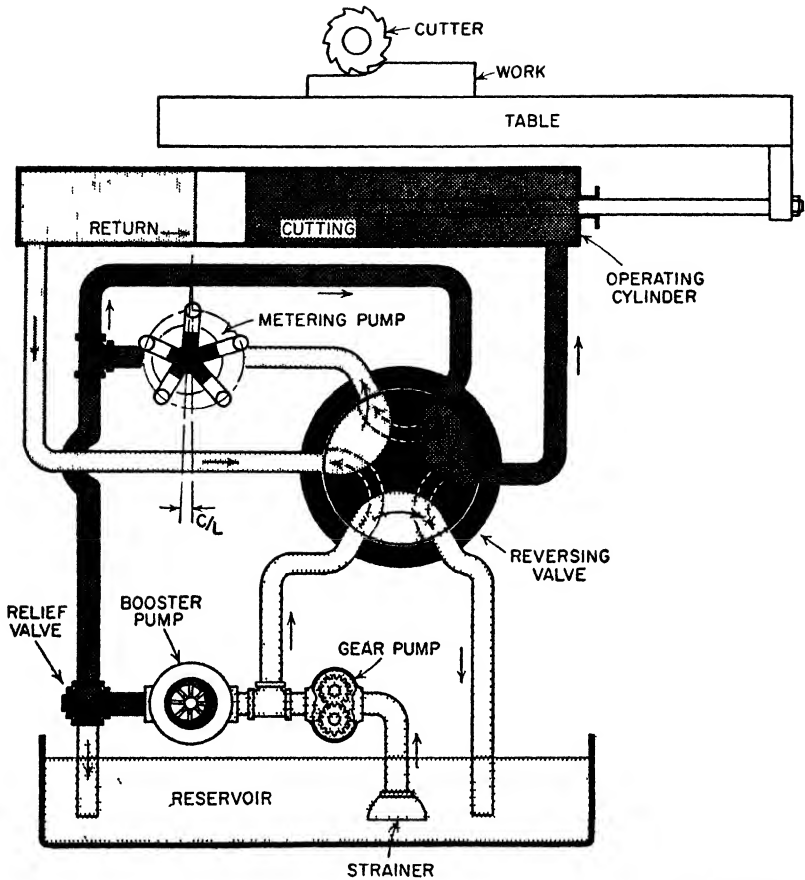


Fig. 15-26. Lock-feed hydraulic system of a milling machine. (The Socony-Vacuum Oil Company)

valve opens sufficiently to permit the excess oil delivered by the pump to return to the reservoir.

*Surface Grinder.* As is shown in Fig. 15-25, moderate oil pressure is developed by a constant-volume or constant-discharge, gear pump which delivers oil under pressure through various valves to a main operating cylinder, where the oil acts upon a piston to reciprocate the worktable. Excess pressure is released to the reservoir through a

spring-loaded relief valve. At the end of each stroke of the worktable, suitable cams throw the reversing valve, thus directing the oil through a wheel infeed cylinder alternately to opposite ends of the main operating cylinder. This wheel infeed cylinder serves the double duty of actuating the ratchet mechanism of the wheel infeed and serving as a valve to direct the oil to and from the operating cylinder. Rate of table travel is regulated by adjusting a throttling valve in the high-pressure line from the pump.

**Variable-volume System.** *The Milling Machine* (Fig. 15-26). Certain machine tools, particularly milling machines, require a slow feed during the cutting stroke. This is immediately followed by a very rapid return stroke (rapid traverse), during which little oil pressure is required. Figure 15-26 shows a lock-feed hydraulic system of a milling machine using three pumps. A brief explanation of how this system operates follows.

A low-pressure gear pump, taking its suction from a reservoir, supplies the suction of a booster pump, which in turn supplies oil pressure to the operating cylinder for the low-speed working stroke. Rate of table travel is controlled by a variable-discharge metering pump, which removes measured quantities of oil in front of the advancing piston. The positive flow of oil to and from the operating cylinder "locks" the working piston and accurately controls its motion. When the reversing valve is thrown, as shown by the dotted lines, the discharge and suction ports of the metering pump are interconnected. The booster pump then discharges entirely through the relief valve, and the gear pump supplies low-pressure oil to the operating cylinder for rapid traverse during the idle return stroke.





# *Metal Band Saws*

---

## CHAPTER 16

---

### **Metal-cutting Band Saws**

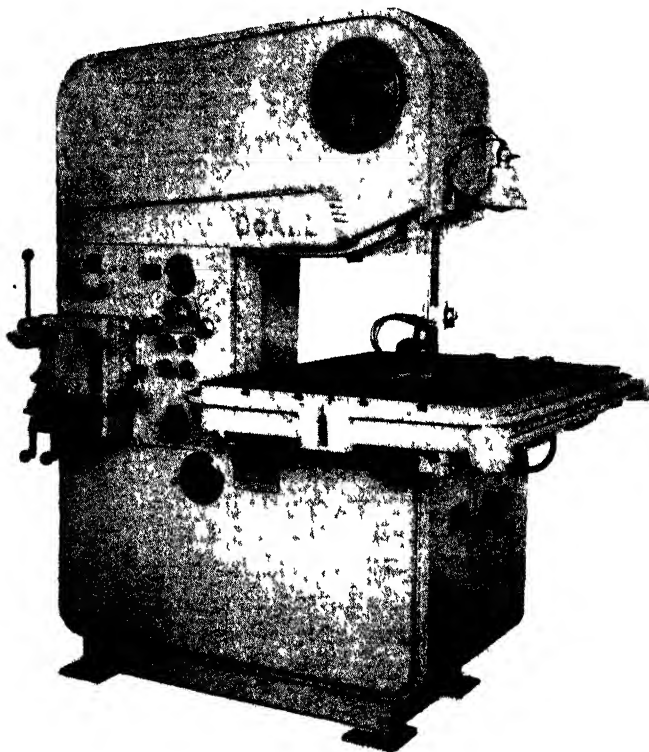
In recent years, metal-cutting band saws have been developed to a very high degree. This was due in part to the demands for high production during the last 15 years. These high-production schedules required enormous amounts of metal of various kinds to be cut, anything in armor-plate steel, in boiler plate, in stainless steels, in alloy steels, and also in fully hardened tool steels. To make such production possible, manufacturers began to look around for a machine tool that could do this job and do it cheaply and effectively. Many found the answer in the *metal-cutting band saw* (Fig. 16-1).

Some of the features of this type of machine tool are:

1. It will cut everything, from asbestos to zinc, whether the material is thick or thin, hard, tough, sticky, soft, or abrasive. Steel, iron, linoleum, rubber, stone, and plastics are cut on this machine.
2. It cuts *all the time*, because it employs an endless band with thousands of sharp teeth moving in one direction. There is *no* back stroke. This means that there is no time lost in noncutting strokes.
3. It cuts direct to layout lines. Because there is no whittling action on the part of the cutting band, it is a simple procedure to guide the work into the band saw in following the layout lines, whether it is making three-dimensional parts or shaping duplicate parts in one operation.
4. This machine, using the proper band tool, can saw, file, and polish work to completion.
5. It saves material, since the narrow saw band cuts only a thin kerf, removing the material in chunks instead of reducing it to a pile of chips. Material salvaged often pays the cost of the blades used.

6. This machine tool has full visibility and permits the operator to inspect his sawing progress as he follows the layout lines.

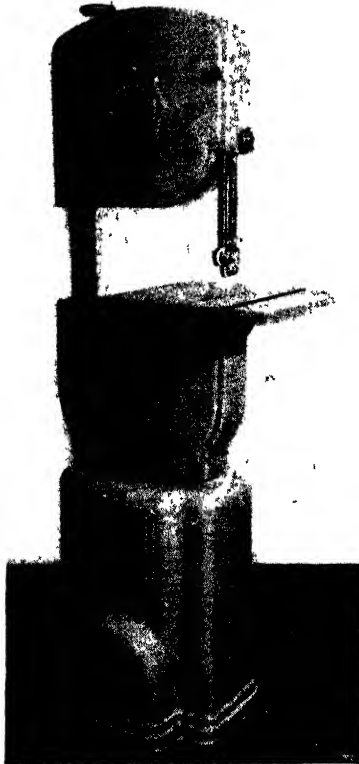
There are several types of metal-cutting band saws on the market, among them, the DoAll Contour-matic (Fig. 16-1), the Tyler



**Fig. 16-1.** The DoALL Contour-matic metal-sawing machine. (*The DoALL Company*)

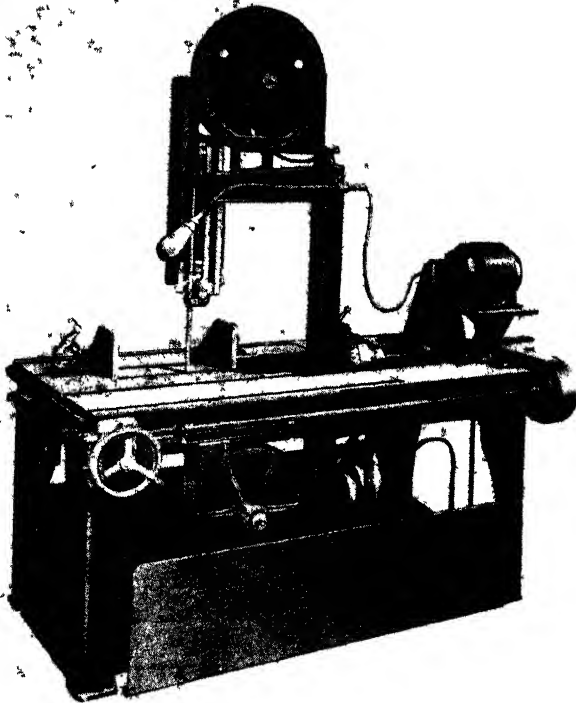
machine (Fig. 16-2), and the Armstrong-Blum machine (Fig. 16-3). Note the differences in design among these machines; however, they all cut metal. Figure 16-4 illustrates the DoAll Contour-matic cutting cams, a typical job on such a machine.

The metal-cutting band saw is made in a number of sizes, ranging in work capacity from 8 to 24 in. in thickness. It will allow pieces to be cut ranging from 16 to 60 in. in throat capacity. Most such machines have variable speeds, but some are equipped with fixed



**Fig. 16-2.** The Tyler metal-sawing machine. (*The Tyler Manufacturing Company*)

speeds. The variable-speed machines have a range from 40 to 10,000 f.p.m., a range that permits efficient cutting of all types of materials. Some machines are hydraulically operated, while others are hand operated. A brief description of one of these machines is given later in this chapter.



**Fig. 16-3.** The Armstrong-Blum sawing machine (*The Armstrong-Blum Manufacturing Company*)

**Band-tool Terminology.** This section sets forth the common terms used in connection with band tools. A band tool may be defined as any band of steel or other material capable of being flexed, onto which cutting elements are processed or mounted for use in parting, shaping, and finishing materials. Common terms, such as *saw bands*, *file bands*, *polishing bands*, denote specific types of band tools.

Four functions of a band tool differentiate it from any other cutting tool: (1) It provides continuous cutting action, (2) it cuts directly to inside or outside layout lines, (3) there is no limitation to the length of the cut, and (4) it removes materials in sections.

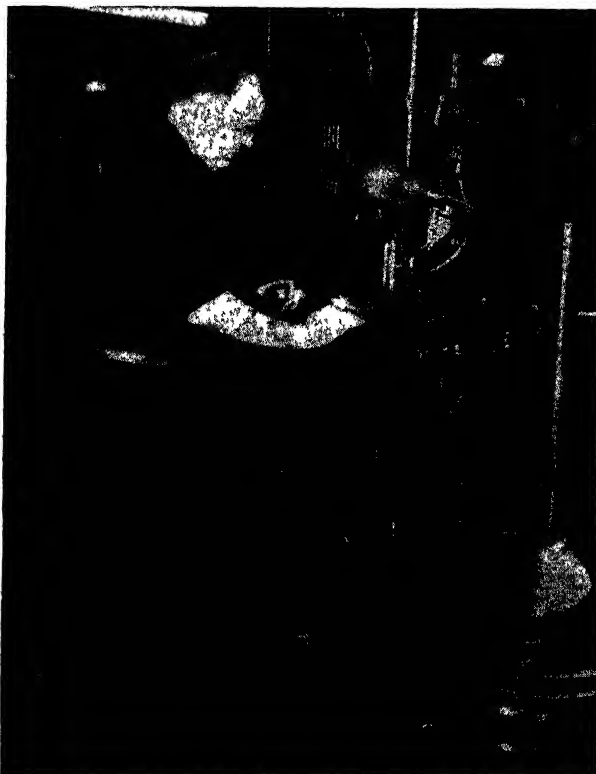


Fig. 16-4. Cutting cams on the DoAll machine. (*The DoAll Company*)

#### **DEFINITIONS: BAND-TOOL TERMS**

*Teeth.* That part of the band tool commonly known as the *front edge* or *cutting edge*. The operation of making these teeth is called *Toothing* (Fig. 16-5).

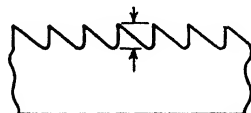


Fig. 16-5. Teeth on a metal band saw.

*Tooth Face.* The surface of the tooth on which the chip impinges as it is cut away from the work (Fig. 16-6).

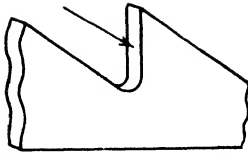


Fig. 16-6. Tooth face.

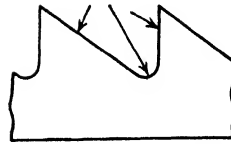


Fig. 16-7. Tooth gullet.

*Tooth Gullet.* The throat within the curved area at the base of the tooth, tooth face, and the back of the next tooth. It acts to remove chips from the cut (Fig. 16-7).

*Tooth Back.* Surface of the tooth opposite the tooth face (Fig. 16-8).

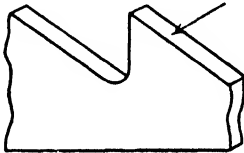


Fig. 16-8. Tooth back.

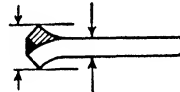


Fig. 16-9. Set of teeth on band saw.

*Set.* The amount of bend given the teeth to create side clearance for the back of the band when it is cutting through a material (Fig. 16-9).

*Set Pattern.* Term used in describing type of tooth set, such as Raker, Wave, Straight, etc.

*Raker-set Pattern.* One unset tooth followed by two oppositely set teeth (Fig. 16-10).

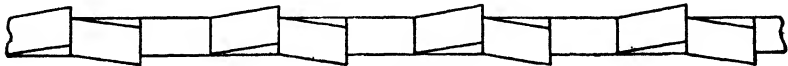


Fig. 16-10. Raker tooth pattern.

*Wave-set Pattern.* Group set, one group of teeth to the right, and the next group to the left (Fig. 16-11a).



Fig. 16-11a. Wave-set pattern.

*Straight-set Pattern.* All teeth are set symmetrically, with one tooth to the right followed by one tooth to the left (Fig. 16-11b).



Fig. 16-11b. Straight tooth pattern.

*Tooth Side-clearance Angle.* Degree of bend of each tooth. The size or spread of this angle depends on the pitch of the saw band and the kerf size desired (Fig. 16-12).

*Kerf.* The cut made by a saw.

*Tooth Rake Angle.* The angle of this surface as measured from a perpendicular line in respect to the back edge of the band (Fig. 16-13).

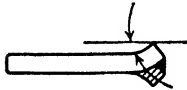


Fig. 16-12. Tooth side-clearance angle.

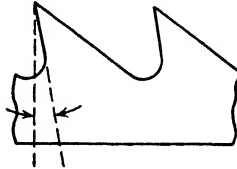


Fig. 16-13. Tooth rake angle.

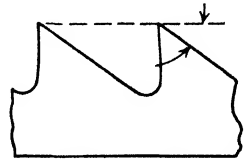


Fig. 16-14. Tooth back-clearance angle.

*Tooth-back Clearance Angle.* The angle of the tooth back as measured in relation to the cutting edge of the band tool (Fig. 16-14).

*Side Clearance.* The difference in dimension between the tooth set and the back of the band tool. The main function of side clearance is to provide space on both sides of the band back to enable maneuvering the work during radii sawing. Proper side clearance also minimizes transfer of frictional heat to the work and prevents leading off (or straying) in making straight cuts (Fig. 16-15).

*Pitch.* Number of teeth per inch. Generally the greater the work thickness, the fewer teeth per inch are required (Fig. 16-16).

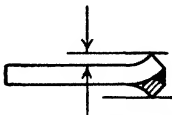


Fig. 16-15. Side clearance.

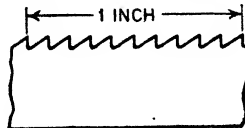


Fig. 16-16. Pitch.

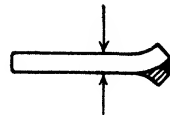


Fig. 16-17. Gage.

*Gage.* Thickness of band back, usually measured in thousandths of an inch to avoid "gage-number" confusion (Fig. 16-17).



*Width.* Measure from tooth tip to back edge of band (Fig. 16-18).

*Swaged Tooth.* Type of set common to wide saw bands and a certain type of circular saws, to create side clearance (Fig. 16-19).

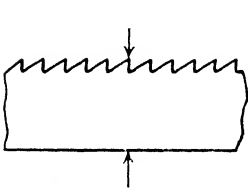


Fig. 16-18. Width.

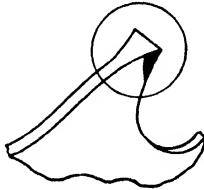


Fig. 16-19. Swaged tooth.



Fig. 16-20. Knife-edge bevel.

*Knife-edge Bevel.* Term used to indicate type of cutting edge on knife-edge bands (Fig. 16-20).

*Beam Strength.* The amount of band-back deflection when subjected to edge thrust or feeding pressure (Fig. 16-21).

*Tensile Strength.* The amount of directly applied pull that a band tool will withstand before rupture. This is usually expressed in pounds per square inch.

*Left Lead.* The left-hand deviation from a true cutting course. A band tool having a tendency to cut toward the left of the operator rather than to follow a natural course has what is termed a *left lead* (Fig. 16-22).

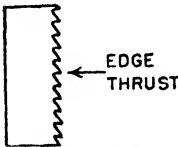


Fig. 16-21.  
Beam strength.

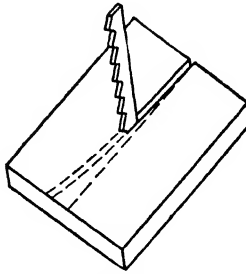


Fig. 16-22. Left lead.

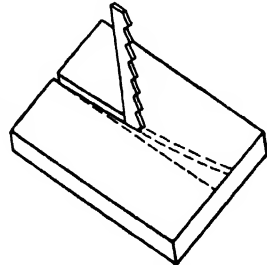


Fig. 16-23. Right lead.

*Right Lead.* The right-hand deviation from a true cutting course. A band tool having a tendency to cut toward the right of the operator rather than to follow a natural course has what is termed a *right lead* (Fig. 16-23).

*Right Twist.* A right twist is described if the band spirals to the right when one is viewing the front edge of a band tool with the teeth in a downward-cutting position (Fig. 16-24).

*Left Twist.* A left twist is described if the band spirals to the left when one is viewing the front edge of a band tool with the tooth pointing in a downward-cutting position (Fig. 16-25).

*Band Tension.* Tautness of band tool between wheels after being placed in operation on the band machine adjusted for operation.



Fig. 16-24.  
Right twist.



Fig. 16-25.  
Left twist.

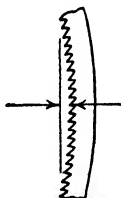


Fig. 16-26.  
Positive  
camber.

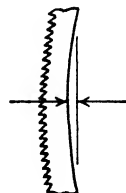


Fig. 16-27.  
Negative  
camber.

*Positive Camber.* The direction of the arc as measured in relation to the cutting edge of the band tool (Fig. 16-26).

*Negative Camber.* The direction of arc measured in relation to the back edge of the band tool (Fig. 16-27).

*File Segment.* That part of a file band comprising the cutting edge which is divided into sections. Each sectional part is known as a *file segment* (Fig. 16-28).



Fig. 16-28. File segment.

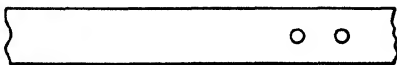


Fig. 16-29. Back band.

*Back Band.* The long steel band on which the spacers and file segments are mounted (Fig. 16-29).

*File Pitch.* Number of teeth per inch as measured along the edge of the file band (Fig. 16-30).

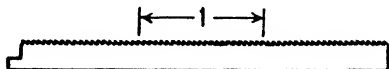


Fig. 16-30. File pitch.

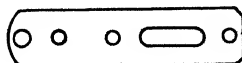


Fig. 16-31. Gate clip.

*Gate Clip.* Small rectangular steel strip on lead end of file band with shoulder rivet attached for joining and locking the two ends of the file band (Fig. 16-31).

*Band Speed or Saw Velocity.* The speed at which the band tool travels over the carrier wheels. This is measured in feet per minute (f.p.m).

*Cutting Rate.* The rate at which the band tool removes metal, usually given in linear inches or square inches per minute.

**Technique of Using Blades.** Proper blade selection from the width of the blade, its tooth shape, pitch, and pattern is determined largely by the material to be cut and its thickness. On thin material a saw of fine pitch should be used. As a general rule, not less than two teeth should contact the work, yet the coarsest pitch possible should be used for maximum chip clearance and minimum friction.

Width is determined by the radius of the cut to be taken. A general rule used by most band-saw operators is to use the largest width possible that permits making the curve without binding in the kerf.

After a new blade has been placed on the wheels of the machine and inserted in the guides, the upper wheel is adjusted so that the blade will run without touching the hardened thrust wheels of the guides. The thrust wheels should come into play only under pressure of cutting. There are various widths of guides to suit different blade widths. The proper guides to use are wide enough to prevent a blade from twisting, yet narrow enough to prevent the teeth from coming into contact with the guide when the back edge of the blade is in contact with the thrust roller. Tension of the blade should be just enough to prevent it from twisting or "wandering" while cutting. A new blade, especially a narrow one, will stretch slightly. The slack should be taken up by adjustment of the saw-tension control. Narrow blades require less tension than wider ones.

Besides a starting hole drilled for internal cuts, holes are drilled generally wherever sharp turns must be made. However, this is not absolutely necessary, since turns can be made by sawing past the corner at a radius and notching out the corner after the cut has been completed and the "slug" removed.

**Types of Blades.** Of the many types of blades manufactured for industrial purposes, nine are mentioned and illustrated here:

Precision	Claw-tooth	Spring-tempered
Friktion	Scallop-edge	Spiral-edge
Buttress	Knife-edge	Diamond-tooth

*The Precision Saw Blade* (Fig. 16-32). This type has teeth so hard that they cannot be nicked by a file, yet the back of the blade is flexible. Run at relatively low speeds, precision blades are used for both ferrous and nonferrous metals and alloys and, in some instances, for wood and plastics. Although they are made in two patterns—the raker and the wave—the former is used exclusively for cutting iron and steel, except in thin sheets, tubing, or angles.



Fig. 16-32. Precision saw blade.

*The Friction-sawing Blade* (Fig. 16-33). Friction sawing (which is explained later) is the new sawing method extensively used in foundries and other metal-working industries for cutting ferrous metals.

These saw bands are manufactured to withstand maximum flexations and for wear resistance at very high friction-sawing velocities. They are not recommended for slow-speed sawing.

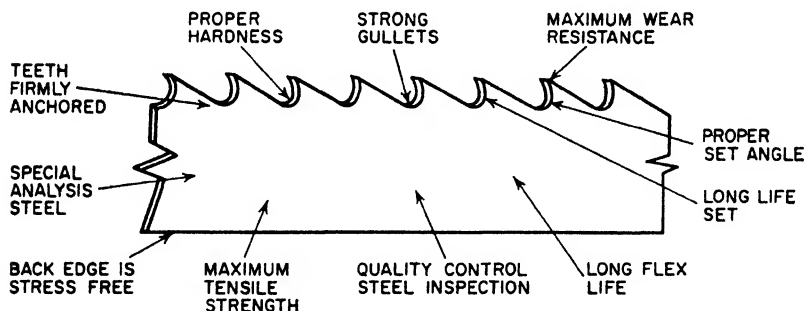


Fig. 16-33. Friction-sawing blade.

With this type of saw and this method of sawing, hard metals and alloys—as stainless-steel castings and milling cutters—can be cut with amazing speed. When the saw is operated at high band speeds, up to 15,000 f.p.m., the material directly ahead of the band saw is softened by the heat created by the friction of the band saw and the feeding force. This enables the teeth to remove the soft materials. Figure 16-34 shows a steel column being sawed by this method. (Note the protective gloves and the eye shields worn by the operator.)

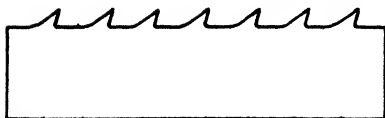
*The Buttress Blade* (Fig. 16-35). Made for fast cutting of wood, plastics, nonferrous metals, and other materials, buttress blades have specially shaped gullets and wide-spaced teeth. This permits the rapid removal of material with a minimum generation of heat



**Fig. 16-34.** Friction sawing of steel column. (*The Tannewitz Works*)



**Fig. 16-35.** Buttress blade.



**Fig. 16-36.** Claw-tooth blade.



**Fig. 16-37.** Scallop-tooth blade.

when the blades are run at high speeds. Teeth are permanently hardened, yet the back of the blade is flexible, to provide long life.

*The Claw-tooth Blade* (Fig. 16-36). Claw-tooth blades differ from other blades in that the cutting teeth have a positive rake which

produces chips more freely than other types of teeth. These narrow band-saw blades are used for cutting light metals and alloys, wood, etc.

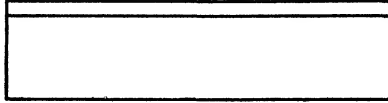


Fig. 16-38. Knife-edge blade.

*The Scallop-edge Blade* (Fig. 16-37). Fast slicing of soft materials is possible with this type of blade. The blade has a scalloped, double-bevel cutting edge, as shown in the illustration. It does not produce a saw kerf like chip-removing blades, but merely separates the material being cut without producing dust or dirt. This type of blade leaves an exceptionally smooth finish.



Fig. 16-39. Spring-temper blade.

*The Knife-edge Blade* (Fig. 16-38). Knife-edge blades have a straight cutting edge, with either single or double bevel. They are used for cutting soft and fibrous materials.

*Spring-tempered Blades* (Fig. 16-39). This type of band saw is frequently used in foundries for trimming castings of light metals, such as aluminum and magnesium.

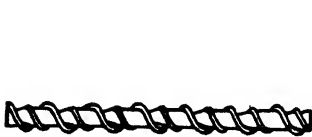


Fig. 16-40. Spiral-tooth blade.

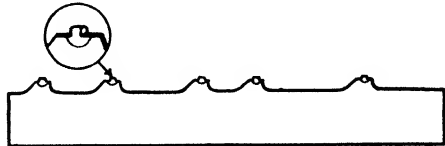


Fig. 16-41. Diamond-tooth blade.

*Spiral-edge Blade* (Fig. 16-40). This type of blade permits sawing in any direction without the necessity of swinging the work. Special saw guides are required when this blade is being used.

*Diamond-tooth Blades* (Fig. 16-41). Hard, brittle materials can be cut to a radius following a layout line with precision comparable to that of conventional contour sawing. Diamond-tooth blades have a

number of cylindrical segments, consisting of diamonds tightly bonded in a sintered tungsten-alloy matrix.

**Friction Cutting or Sawing.** The most efficient and the easiest method for band-machining many jobs in sheet, channels, angles, and tubing of steel, stainless, monel, and other tough ferrous alloys in sections of  $\frac{1}{2}$  in. or less, is that of friction cutting or sawing. It is much faster than all the other conventional methods of sawing previously used. It has been of tremendous help to the manufacturers of air frames, for trimming, blanking and toolroom work. In the field of plastics, this type of cutting stands not only supreme, but unchallenged, as the ideal method of cutting.

In friction cutting, the metal directly in contact with the blade teeth is heated to incandescence and becomes quite soft. The teeth brush away the softened material. The heat used to heat the metal is generated by the friction between the material being cut and a fast-moving saw blade. The secret is the fast speeds of the saw blade, up to 15,000 f.p.m.

Friction cutting produces a smooth finish and a slight burr, which can be easily removed. There is very little chatter when pieces are cut by this method.

**Setting Up the Band Tool.** Metal-cutting band saws are put up in coils measuring 100 to 500 ft. in length. Whenever a new band tool is needed, the length required is measured and cut off from the coil.

To determine the proper saw-band length to fit any two-wheeled band machine, add twice the distance from the center of one wheel to the center of the other wheel, then add the circumference of one wheel to that figure, and the result will be the total band length.

If the band-length measurement is calculated when the two wheels are at their greatest distance apart, it is important to deduct a slight amount from this figure to allow for stretching when the band tool is placed under tension.

After the required length is calculated and that length cut off from the coil, the next step is to weld the ends together, forming a continuous cutting tool. This is done on the DoAll by butt-welding the ends, using the butt welder attached to the machine. This is a simple job, completed in a very few minutes.

After being welded, the saw band must be annealed at the point

of weld. Otherwise this welded area, being brittle, will break when flexed. The process of annealing also is done right on the machine, simply by placing the welded portion in the proper position on the annealing attachment and pushing the annealing button.

After the annealing, the portion welded and annealed must be ground, to remove the bead formed by welding. Check for the correct thickness in gage on the machine. Now the saw band is ready to be placed in the machine.

When placing the saw band in the machine, make sure that the teeth are pointed *downward* in the direction of the band travel. This is *very important*.

*Mounting a Band Tool.* When mounting a band tool, it should be placed on the crown of the wheels as close to the center as possible. The next step is to place a slight tension on the band tool and revolve the upper wheel by hand until the band has found its natural operating position on the wheels. If the band fails to track in the right position, use the upper wheel tilt control to tilt the wheel so that the band will run in the right location. After the band has been tracked properly and is in slight contact with the top and bottom back-up bearings of the guides, the band tension should be increased to the recommended operating tension.

**The DoAll Contour-matic Sawing Machine** (Fig. 16-42). This machine tool can cut, file, and polish, provided that the proper band tool is used. Some of the parts are briefly described in the following sections.

*Job-selector Dials.* There are two job-selector dials on this machine. The low-speed dial, used for extremely accurate sawing and filing, is located on the upper door of the machine. It gives a ready reference to the correct saw and file bands to be used in the machining of 55 basic materials, along with the correct operating speeds. The high-speed and friction-sawing dial, located on the rear of the machine, covers 130 materials for either high speed or friction sawing. Study these dials and learn the various settings.

*Table Tilt.* The worktable is mounted on a trunnion providing adjustment of 10 deg. to the left and 45 deg. to the right. The ratchet wrench, extending out of the frame under the table, is for locking the table trunnion at the desired angle. Pointer and degree segments are attached directly to the trunnion, indicating the angle



at which the table is set. The table tilt is controlled by a hydraulic piston, which is operated by the table-tilt knob on the control panel. Loosen the ratchet wrench before tilting.

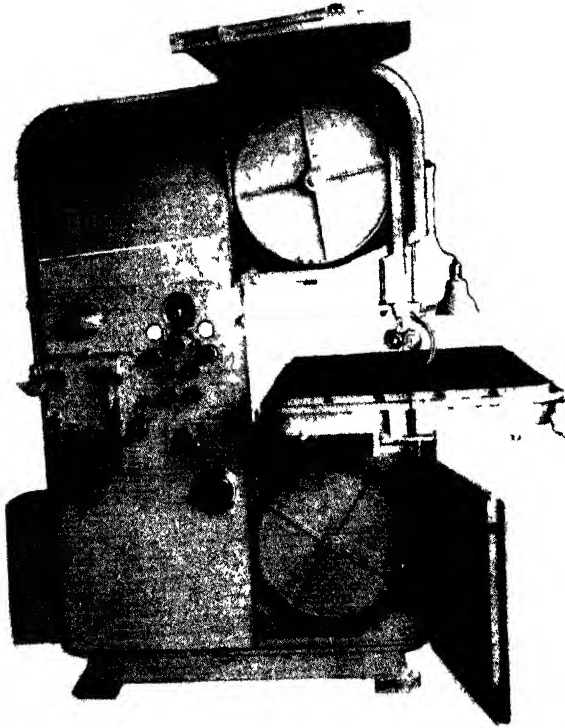


Fig. 16-42. The DoALL Contour-matic machine showing the wheels on which the band saw is mounted (The DoALL Company)

*Bull Welder.* This is a complete unit, attached to the machine and used to weld the ends of the blades whenever a new blade is to be mounted in the machine.

*Tension Gage.* A gage on the control panel shows the tension of the blade in pounds per square inch.

*Feed-pressure Gage.* When power feed is used, this gage will indicate the pressure of the automatic feed.

*File and Saw Guides.* These guides control the side play of the file or band saw. There are three types in general use. For practical purposes, they may be called the *roller* type, the *insert* type, and the *file-band* type.

Those of the roller type are generally used for certain antifriction, high-velocity production applications, and the insert types for low-velocity precision work. The file type is used only when a file band is mounted in the machine.

*Saw Wheels.* The saw-carrier wheels, used for the tracking of the saw blade, are covered with tough neoprene or rubber vulcanized to a steel band. These tires eliminate wear on the saw teeth and, with proper care, will last for a considerable time.

**Operating Speeds.** The DoAll has a speed range of 40 to 10,000 f.p.m. (band-saw travel), controlled by the three speeds of the transmission and the variable adjustment in each speed. Shift the transmission into the speed range in which the sawing is to be done. To shift gears, stop the machine, shift to the desired gear and, while holding the shift lever in the desired position, start the machine. As the machine starts, gears will mesh and the shift lever will slide into position.

Low-speed gear gives blade speed from 40 to 300 f.p.m., as shown on the inside dial of the speed indicator. Medium-speed gear gives blade speed from 240 to 1,800 f.p.m., as shown on the middle dial of the speed indicator. High-speed gear gives blade speeds from 1,440 to 10,000 f.p.m., as shown on the outside dial of the speed indicator.

Proper cutting speeds are important for conserving the saw band. Using incorrect speeds tends to wear out the band saw and slows down the cutting. If the correct speed is maintained, the saw will cut faster and do clean work. The pressure exerted on the work depends on the condition of the saw, the stock thickness, and the skill of the operator. The stock can be fed as fast as the saw will cut without putting undue pressure on the saw and the saw guides.

**Table Feeds.** The table is drawn by a hydraulic piston actuated by oil pressure. The table-feed control knob controls the forward, stop, and reverse motions of the table. The rate of feed can be varied by turning the table-feed pressure knob.

Adjust the feed to give maximum cutting speed for each particular

job without overstraining the saw blade or causing the saw to twist or bow.

**Coolant and Lubricant Agents.** Many materials cannot be cut without the use of coolants or lubricants, and many other materials can be cut more efficiently when these agents are used. The gains are additional band-tool life, improved finish, and better production rate.

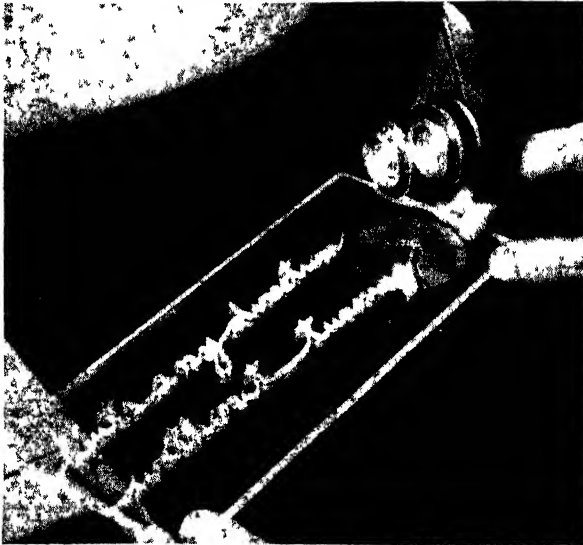


Fig. 16-43. Lettering on plastics. (*The Tyler Manufacturing Company*)

When certain grind bands and diamond-tooth band tools are used for cutting hardened alloys, voluminous coolant with sufficient wetting and flushing action is required. The coolant is forced to the point of cut, and the pumping action that is secured through the design and velocity of the band tool in operation enables additional, uniform coolant distribution. These band tools would be quickly ruined if they were allowed to run without sufficient coolant and adequate coolant distribution, as the cutting elements must be kept clean by having the particles that are cut flushed away.

Tool steels, mild steels, and all conventional alloys can best be cut by the use of an agent having lubricating qualities. In general,

as the wear-resistance quality of the material increases, the greater is the need of lubricating, in order to counteract the abrading action of the wear elements.

For information about specific coolants and lubricating agents, consult any manufacturer's catalogue, such as those of the Socony-Vacuum Oil Company, the DoAll Company, and others.

**Typical Operations on a Metal-sawing Machine.**

Illustrations that present the versatility of the metal-sawing machine can be found in Fig. 16-43, where a lettering job is being done on plastics; Fig. 16-44, where the power feed is in use for sawing; Fig. 16-45,

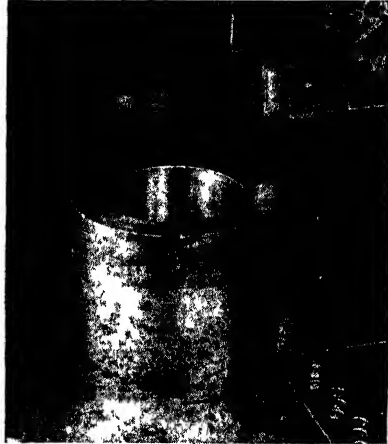


Fig. 16-44. Using power feed. (*The W O Barnes Company*)



Fig. 16-45. Exterior sawing on wood. (*The Tyler Manufacturing Company*)



Fig. 16-46. Interior contour sawing (*The Tyler Manufacturing Company*)



Fig. 16-47. Filing. (*The DoALL Company*)

where an exterior contour-sawing job is being done; Fig. 16-46, showing an interior sawing job; and Fig. 16-47, showing an operator using a filing machine.

### SOME OPERATIONS ON THE METAL BAND SAW

#### Straight-line Sawing with Table in a Horizontal Position

1. Secure piece to be cut and draw layout lines on it.
2. Determine the proper kind and size of saw blade to be used for the job. This is done by consulting the job-selector chart mounted on the machine.
3. Secure the proper saw blade and mount it on the machine.
4. Determine the correct cutting speed for the job by consulting the job-selector chart.
5. Set the machine for that speed.
6. *Wear properly fitted goggles.*
7. Place the work on the table and lower the saw guides until they are within  $\frac{1}{2}$  in. of the highest point of the workpiece.
8. Clamp the guides in position.
9. Push the starting button and allow the machine to build up its speed to the required speed.
10. Bring the material *slowly* into contact with the revolving blade at the beginning of the layout lines.
11. Advance the work by exerting a light pressure, but keep it steady. *Do not push too hard. Feed slowly. Keep hands away from the revolving blade.*
12. Follow the layout lines until the job is completed.
13. *Stop* the machine and remove the material.
14. Remove the waste and clean the machine for the next piece.

#### Straight-line Sawing with Table at an Angle

1. Secure material to be cut and draw layout lines on piece.
2. Determine the proper kind and size of saw blade to be used for the job by consulting the job-selector chart mounted on the machine.
3. Secure the saw blade and mount it in the machine.
4. Determine the correct cutting speed for the material to be

cut by consulting the job-selector chart. Set the machine for that speed.

5. *Wear properly fitted goggles.*
6. Tilt the table to the desired angle and clamp the table securely.
7. Start the machine and wait until the saw has reached full speed.
8. Place work on table and move it close to the saw blade.
9. Adjust the saw guide to the proper position (about  $\frac{1}{2}$  in. from the highest point on the work).
10. Gently and with a slight but steady pressure, guide the work along the layout lines until the job is completed.
11. Stop the machine and remove the job.
12. Remove the waste stock; clean the machine.
13. The machine is now ready for the next piece.

#### Cutting Exterior Contours

1. Secure the material to be cut and lay out the required contour on the surface.
2. Determine the size and kind of saw blade required.
3. Determine the proper cutting speed.
4. *Wear properly fitted goggles.*
5. Lower the guides to within  $\frac{1}{2}$  in. of the highest part of the piece.
6. Clamp the piece in position.
7. Start the machine and allow it to run until it has reached its full speed.
8. Bring the job *slowly* into contact with the saw blade.
9. Advance the work steadily and follow the layout lines very carefully. *Do not push the work too hard.*
10. Use cutting compound if necessary.
11. At the end of the cut, stop the machine and remove waste.

#### NOTE:

1. If the contour has some sharp curves, it is suggested that a narrow saw be used.
2. Round or irregularly shaped pieces should be held in a vise or jig.

**QUESTIONS ON  
METAL-CUTTING BAND SAWS**

1. Name at least three features of a metal-cutting band saw.
2. Name four functions of a band tool that make it different from any other cutting tool.
3. Define the following: kerf, pitch, left lead, right twist, band velocity, and cutting rate.
4. Name the three different types of patterns found on band saws.
5. Name five types of saw blades and describe them briefly.
6. Name at least one use for each of the various saw blades mentioned in the text.
7. Describe friction sawing.
8. Tell how you would mount a new saw blade in a metal-cutting band saw.
9. How should the teeth on the saw blade point when being mounted on a machine? Why?
10. Describe the value of the job-selector chart on the DoAll machine.





# *Metallurgy*

---

## CHAPTER 17

---

### **Metallurgy, Properties, and Uses of Ferrous Metals and Alloys**

A clear understanding of the fundamentals of metallurgy would undoubtedly be very helpful to every machinist and machine-tool operator. Such a knowledge would give him at least a partial picture of what goes on within a piece of metal while it is being cut. This, in turn, would make it far easier for him to understand why cutting tools must be designed in a certain way, held at a specified angle, and applied at a given speed and feed for best results in cutting one type of metal; and why they must be designed, held, and applied quite differently for best results in cutting a different type of metal.

The advancement of the science of metallurgy has made better metals available, as well as having added a knowledge of how such metals may be more readily machined by the use of special alloys in machine-driven cutting tools. Thus, metallurgy and machines are interdependent.

Unfortunately, however, the science of metallurgy is too broad and far too technical to permit detailed explanations and descriptions here. Instead, a brief nontechnical explanation will be given.

**Definition and Scope.** Metallurgy deals with the derivation of the metals from their ores, or the condition in which they are found in the earth, with their refinement or purification, and with their manufacture into various shapes and forms that are used in industry. Metallurgy also includes the scientific study of these processes and the development of new metals. There are many other functions of the science of metallurgy that are too numerous to mention.

Because this science is so broad and vast, it has been divided into two phases: *chemical metallurgy* and *physical metallurgy*. The former

deals with the chemical actions in the processes of melting and refining metals; the latter, with the physical behavior of the metals during the shaping and treating operations. In this text, only the latter will be touched upon.

**Atoms and Their Behavior.** Atoms are the tiny individual units of an element that go to make up any metal mass. The atoms of a given kind of metallic element are all identical in size, shape, and weight: but they differ in these respects from the atoms of other kinds of metallic elements.

When metal is in a molten state, the atoms which compose its mass arrange themselves in a hit-or-miss fashion, entirely without definite order or regular pattern. Because of this thorough internixing of the atoms, metals that have different characteristics can be produced by combining atoms of different metallic elements when they are in a molten state. This phenomenon will be made clearer after the study of alloy steels is started as this is the way in which alloy steels are made.

When the molten metal starts to cool, the atoms begin to arrange themselves in an orderly cubical pattern around points called *nuclei*, scattered throughout the molten metal. Each group of atoms grows in number until it runs into another group, formed around another nucleus. Then its growth stops.

The group of atoms arranged in a cubical pattern around a single nucleus is called a *grain*. Grains are irregular in shape and vary in size according to the composition of the metal and the conditions under which the grains are produced. These factors determine the number of nuclei about which groups of atoms can form. The more nuclei there are, the smaller is the grain, and the harder and stronger, generally, is the metal.

**Properties of Metals.** Specific metals and alloys have specific properties, and a knowledge of these not only enables the machinist to determine a metal's suitability for a definite use, but makes it possible for the heat-treater to modify the treatment, to the end that the metal may be best for the specific job. Testing methods have been devised for these properties that will predict with some assuredness how a metal will behave in actual service.

Of the many properties that characterize metals—such as strength, plasticity, elasticity, brittleness, toughness, ductility—

only three are important for the present study. They are *brittleness*, *toughness*, and *ductility*. These will be discussed from the viewpoint of the machinability and finish of metals.

*Machinability* is a much-abused term, but it is generally used to express the manner in which various metals will react to the action of a cutting tool. The variations in the machinability of metals are, to a large extent, a reflection of the variations in the characteristics of the crystalline structure and the grain pattern of the metals.

*Finish* is the term generally used to describe the degree of smoothness which the surface of the metal acquires as a result of a machining operation. To a large extent, finish is influenced both by the character of the metal as reflected by its structure, and by the methods and conditions under which the metal is cut.

Upon the basis of these fundamentals, let us attempt to show why metals have different characteristics and how these characteristics affect metal-cutting operations.

#### **DEFINITIONS: PROPERTIES OF METALS**

Of all the individual properties each kind of metal possesses, the most outstanding for the purpose of comparing different kinds of metals are those of hardness and strength. Other properties of metals affect their cutting ease, and some of them affect their finish. However, the most important properties of metals will be defined.

**Hardness.** The property of a metal which gives it the ability to resist being permanently deformed when a load is applied. The harder a substance, the greater is its resistance to deformation.

The hardness of materials may be checked in many ways. Chapter 19 deals with methods of testing the hardness of metals. Study that part of the chapter and learn the various methods of hardness testing.

**Strength.** The ability of a material to resist deformation. The property of *plasticity* is usually associated with strength. Strength with plasticity is the most important combination of properties that a metal can have. Plasticity may be defined as the ability to take deformation without breaking. If metals having this combination of properties are used in vital parts of structures and machine tools that may become overloaded, serious trouble can be avoided. For example, should a member of a bridge become overloaded, plasticity will allow the overloaded part to flow, so that the load becomes redistributed to other parts of the structure. It will save that part from breaking.

**Brittleness.** A property belonging to metals which cannot be deformed permanently. Brittle metals break easily. Cast iron is brittle, and castings may at times break by just being dropped to the floor of the shop.

**Toughness.** The property of some metals wherein they possess high strength and the ability to deform permanently without rupture.

**Ductility.** The property of some metals of being able to be drawn from a larger size to a smaller size of wires. Metals used for wires are ductile metals.

**Types of Metals.** The machinability (ease of machining) of various metals is closely associated with their degree of brittleness, toughness, and ductility.

*Brittle* metals may be visualized as being made up of small grains (irregular in shape), held together by a hard, glasslike bonding material. Because this bonding material is very hard at low temperatures, it will fracture readily and will also transmit the tool pressure to the grains, thereby contributing to their being rapidly fractured. By visualizing the structure of brittle metals (Fig. 17-1) in this manner, it is possible to understand why the action of the cutting tool on such metals causes the formation and rapid breaking off of short, sharp chips.

When brittle metals are cut on a lathe, the pieces that form the chip break off very close to the cutting edge, resulting in a jerky, vibratory movement of the tool. This action results in comparatively rapid tool wear, because of the rapid vibration and excessive amount of friction generated in a small area close to the cutting edge.

The act of cutting brittle metal (Fig. 17-1) may be compared with shoveling icy snow, in that both the brittle metal and the icy snow break off in short pieces when sufficient pressure is applied.

*Tough* metals may be visualized as being made up of moderate-sized grains, held together by a bonding material which is strong and tough, yet more plastic at low temperatures than that of brittle metals. For this reason, when tool pressure is applied to tough metals, the grains will slip and deform rather than fracture, making it necessary for the pressure exerted to be great enough to force the tool through the deformed grains as cutting progresses. By visualizing the structure of tough metals in this way (Fig. 17-2), it is possi-

ble to understand why more tool pressure is required and why high temperatures are generated.

When tough metal is cut on the lathe, the chip formed is a more or less continuous ribbon. The tougher the metal, the greater is the pressure required to cut it, and the higher will be the tool tempera-

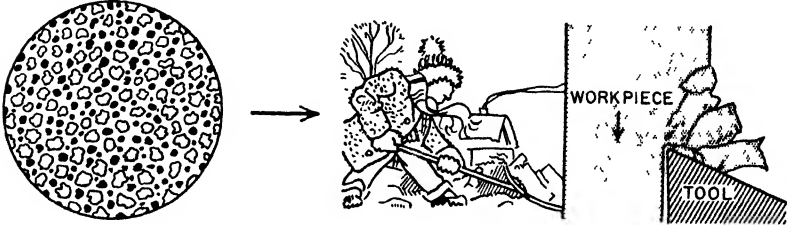


Fig. 17-1. Brittle metals. (The Shell Oil Company)

ture developed on account of grain distortion, tool and chip friction. Thus, tough metals cause rapid tool wear.

The act of cutting tough metals may be compared with the shoveling of tightly packed snow (Fig. 17-2), in that both will form a fairly long "chip," which will hold together and exert fairly constant pressure as it rubs over the face of the tool.

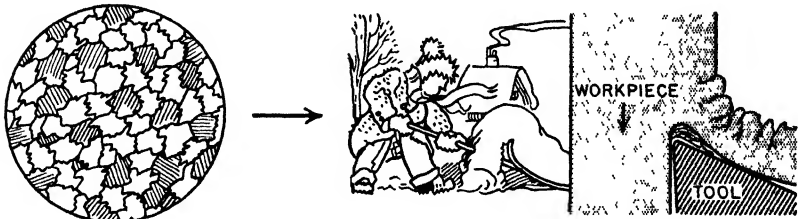


Fig. 17-2. Tough metals. (The Shell Oil Company)

Ductile metals may be visualized as being made up of large-sized grains held together by a bonding material of a relatively soft, plastic nature. For this reason, when it is subjected to tool pressure, the bonding material, being more plastic, will allow the grains to slip over each other rather than transmit the pressure to the grains, thereby contributing to their fracture. Through such visualization of the structure (Fig. 17-3) of ductile metals, it is possible to understand why less tool pressure is required and why higher speed can be used in cutting ductile metals.

When a ductile metal is cut on a lathe, the greater plasticity of its grain-bonding material and the ductility of its own grain structure tend to accelerate the "piling up" of small particles of the chip on the cutting edge of the tool, where it may readily be smeared over the surface of the workpiece.

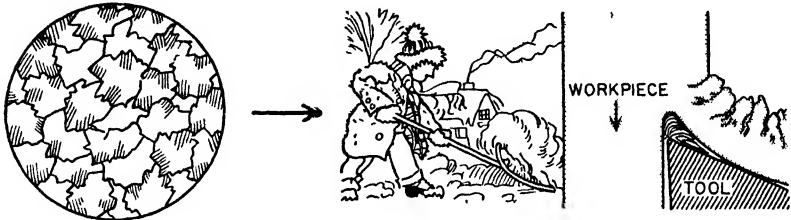


Fig. 17-3. Ductile metals (*The Shell Oil Company*)

The act of cutting ductile metals may be compared with the shoveling (Fig. 17-3) of soft, mushy snow, in that there is a repeated "packing" or "slipping-off" action in the grain structure, as the "chip" is formed by the pressure of the tool.

### QUESTIONS ON PROPERTIES AND TYPES OF METALS

1. Why is the knowledge of metallurgy important to the machinist?
2. Define chemical metallurgy; physical metallurgy. With what phases of the entire science of metallurgy does each deal?
3. What are atoms? Are they alike for a metal? Are they alike for different metals? Explain.
4. What is a grain?
5. Name five properties of metals. Define each.
6. What is meant by machinability? How can the knowledge of machinability be helpful to the machinist?
7. Define finish. Give two examples of types of finishes on metals.
8. What are some differences between brittle, tough, and ductile metals?

### THE PRODUCTION OF IRON

A working knowledge of the way iron, steel, and other metals are manufactured is very desirable for the young apprentice or machinist. It tends to give him a keen appreciation of the value and uses

of the materials of his trade; it develops pride in workmanship; it enables him to use and develop good trade judgment when he has to decide just what metal to use for a particular job. The development of all these abilities is most desirable and important to everyone engaged in the machine trade.

**Iron Ores.** Iron ore is the essential raw material used in the manufacture of iron and steel. An iron ore may be defined as a mixture of iron, oxygen, and other elements. Iron ore is abundant. It is found in every geographic region on the globe, just about every state in the United States, and in almost every rock formation. The largest iron-rich ore deposit ever developed is in the Lake Superior region in Michigan and Minnesota.

Some of the iron ores mined are *hematite*, *limonite*, and *magnetite*.

*Hematite* comes in a variety of forms, ranging from compact granular masses to loose powdery earth. It varies in color from a brilliant black to a brick red—its most common color. It contains about 70 per cent of iron, and this makes it a rich ore.

*Limonite*, commonly called *brown ore*, has much the same chemical composition as hematite, except that it contains water. Before this ore is shipped to the steel plants, it is roasted, to drive off the water, and the resulting material is red hematite.

*Magnetite*, so-called because of its magnetic qualities, is heavy and black. It contains a higher percentage of iron than any other commercial ore but, unfortunately, it is not found in abundance.

Among the elements usually found in iron ore are sulfur, phosphorus, and silicon. There are still others, but they occur in very small amounts.

**Mining of Iron Ore.** Iron mines are sometimes underground, with deep shafts and connecting galleries; while in other iron mines the ore lies close to the top of the ground. When the ore is deep in the earth, the mining method is called *shaft* mining; when it lies near the surface, the method is called *open-pit* mining. Figure 17-4 shows a panoramic view of the largest open-pit iron mine in the world, known as the Hall-Rust pit of the Oliver Iron Mining Company, in Minnesota. In mining by this method, the ore is scooped up by power shovels directly into waiting cars, in which it is shipped. In shaft mining, the ore is extracted from the earth at depths varying from 500 to 2,500 ft.



**Refining of Iron Ore.** The relative value of iron ores does not depend so much upon the iron they contain as upon the cost of separating them from the different elements which are found together with them. As the ore is practically "iron rust mixed with dirt," its value is reduced more or less by the different varieties of "dirt" mixed up with it. Lime and magnesia are good to a certain



Fig. 17-4. An open-pit iron mine. (*American Iron & Steel Institute*)

extent, because these materials are used later on in the refining process. Alumina is not so desirable, and phosphorus is highly undesirable. A little manganese does no harm, but the smaller the amount of sulphur present, the better.

The ore is usually transported by freight cars and ore-carrying boats to lake ports and then shipped to inland centers for refining. This refining, done in *blast furnaces* (Fig. 17-5), constitutes the first step in the making of iron and steel.

*Blast Furnace.* The blast furnace is pretty much like an old-fashioned base-burner coal stove. Fuel is fed in at the top and air at the bottom, with the hottest fire in the fire pot at the base. At times, both burn dull and cold, forming the same clinkers and, as the coal in the top of the base-burner slips down after a clogging clinker gives way, so does the load of a blast furnace; the only difference

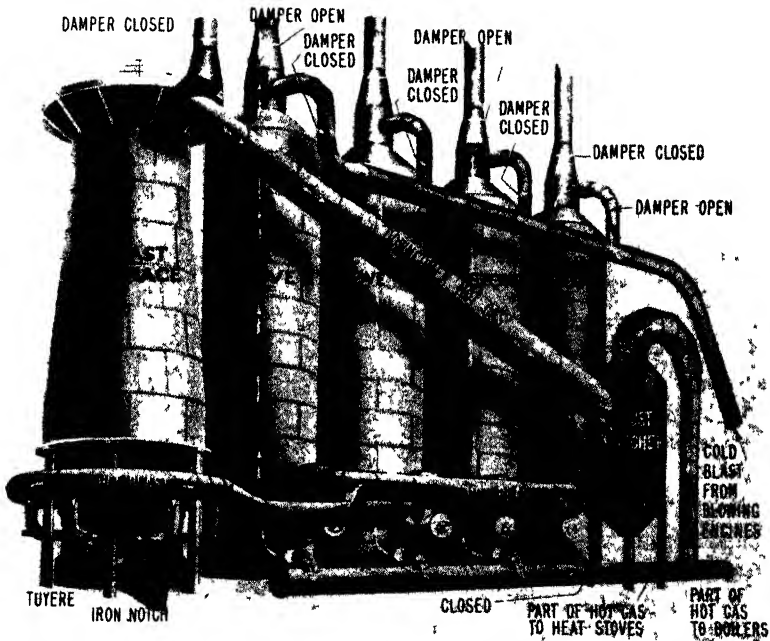


Fig. 17-5. The blast furnace with its stoves (American Steel & Wire Company)

between the two is one of size and weight, the base-burner's load being two buckets of coal, while the blast furnace's load is about 2,200 tons in 24 hours.

Figure 17-5 shows a blast furnace. Four stoves accompany each furnace. They are lined with firebrick and heated red hot. Only one stove at a time is used to make hot blast for the furnace, 40,000 to 60,000 cu. ft. of cold air per minute from blowing engines entering the one hot stove while the other three are being heated. The cold blast is shifted to a fresh hot stove every 2 or 3 hours. Heated to

1200° F., the blast passes through the hot-blast main to the bustle pipe around the furnace, then down and through the water-jacketed tuyeres into the furnace at the hottest point, 3500° F. The blast pressure is usually 15 lb. per sq. in. This hot blast furnishes about one-fifth of the total heat of the furnace. Before the blast is heated, it is refrigerated, to take out the moisture. Heating and refrigerating increase the efficiency over old-fashioned cold blast 70 per cent. The blast, passing through the furnace, becomes heavily impregnated with gas and rushes out through the downcomer. The gas is loaded with coke dust and other particles swept up while passing through the furnace, and these are dropped into a dust catcher, from which the gas passes upward and downward through the hot-gas main in a red-hot gush of fire into three of the stoves and out through the tall chimneys. A furnace makes more gas than is necessary to heat its stoves, so some of it is diverted to boilers making steam for blowing engines or is further cleaned and used to run gas engines for blowing.

In Fig. 17-5, follow the arrows starting at the right and follow the travel of the blast.

*Charging the Furnace.* A blast furnace works continuously, 24 hours a day, and every 6 hours, the molten iron is run off. For that reason, ore, coke, and limestone are charged constantly into the top of the furnace.

Every few minutes or so, a skip car runs up an incline from the charging floor to the top of the furnace and dumps a *charge* of ore, coke, and limestone into the furnace. There are generally two skip cars. While one is climbing up with its load, the other is descending empty. The raw materials for each load are weighed almost with the care taken by chemists in a laboratory. By reading dials in the control room at the bottom of the skip hoist, the operator knows the level of material within the furnace and regulates the charges of raw materials accordingly.

To make one ton of "pig" iron (the product of the blast furnace, Fig. 17-6) requires almost 2 tons of iron ore, nearly 1 ton of coke, and  $\frac{1}{2}$  ton of limestone, and  $3\frac{1}{2}$  tons of air in the blast.

Experiments have been made for some time in the use of oxygen with air in the blast. The purpose of the oxygen is to enrich the air blast and increase combustion of the coke, thereby speeding up the whole process.

*Within the Furnace.* Now that we have charged the furnace with raw materials and the hot blast is rushing in, let us look at what is taking place inside the furnace.

Figure 17-7 shows a cross-sectional view of a heating stove and blast furnace. The hot-air blast entering the furnace at about  $1000^{\circ}$  F. makes the coke burn at white heat. This causes the coke to give hot carbon monoxide gas. The gas streams upward and takes



Fig. 17-6. A pile of "pigs."

some of the oxygen from the iron ore, leaving a spongy mass. Notice that the iron is not yet liquid. As the charge descends farther into the hottest part of the furnace, where the temperature is nearly  $3000^{\circ}$  F., the iron forms into liquid drops, which trickle down into a pool 3 or 4 ft. deep at the bottom of the furnace, called the *hearth*.

Meanwhile, the limestone has done its purifying job. It takes up the impurities from the iron ore and forms liquid *slag*. Because slag is lighter than iron, it floats on top of the liquid metal. This slag is removed from the furnace before the furnace is tapped.

*Tapping the Furnace.* Every 6 hours, the furnace is tapped. Tapping is the process of removing the liquid iron from the furnace.

From 150 to 375 tons of iron are obtained at each tapping, depending upon the size of the furnace. From the tap hole, which is opened at the time of tapping, the molten iron flows out and down a trough. At the end of the trough, the molten metal pours into a huge con-

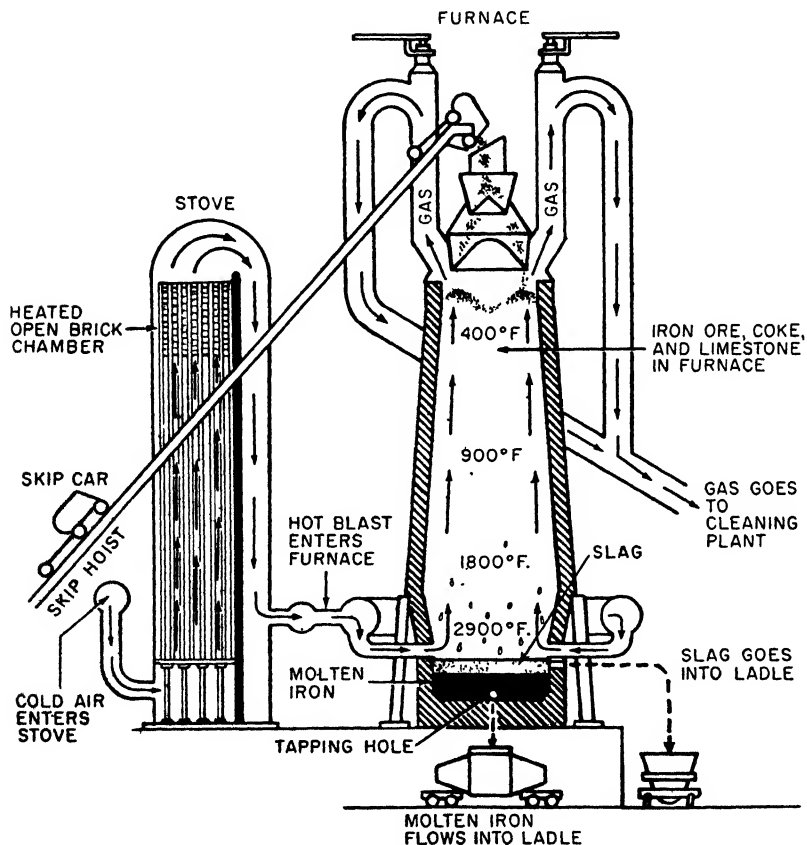


Fig. 17-7. Cross section of heating stove and blast furnace. (United States Steel Corporation)

tainer, or *ladle*. These ladles keep the iron in a molten state while delivering it to the steelmaking departments.

Sometimes the molten iron is poured directly into a series of molds mounted on a slowly moving endless chain. In the molds, the iron solidifies into "pigs" (Fig. 17-6), weighing 50 to 100 lb. each. These

are usually sold to foundries that make cast-iron products and to steel mills that do not make their own pig iron. At such mills, pigs are charged into open-hearth furnaces.

The slag is run off from a separate hole, called the *cinder notch*, and flows down another trough into a ladle. Slag may be used in the manufacture of cement and wall-board, or it may be made into mineral wool for insulation materials. Crushed into small pieces, it is also used in the bed of railroad tracks, in the construction of highways, and as a soil conditioner to overcome acidity.

During the tapping (sometimes called *casting*) of the furnace, samples of the molten iron are taken from the trough and poured into small molds. When the samples have hardened, they are analyzed in the chemical laboratory. This is extremely important, because the quality of the iron determines to a great extent the quality of the steel made from it.

**Cast Iron.** The principal task of the blast furnace is to supply pig iron to be made into steel, but a considerable quantity of iron is used for a variety of cast-iron products. About 5 million tons of pig iron are used each year for making iron castings.

Cast iron is so named because it is shaped, or cast, in a mold. It is granular in form, with a high carbon content. It cannot be forged, rolled, or tempered. Some efforts to anneal it have been successful.

Pig iron is usually remelted and suitably treated when used to make castings. The type of furnace used is called a *cupola* (Fig. 17-8).



Fig. 17-8. Skip-hoist cupola charger applied to cupola. (Whiting Corporation)

Foundries convert pig iron into a variety of castings, the principal ones being *gray-iron castings*, *chilled-iron castings*, *alloyed castings*, and *malleable-iron castings*. This is done in different ways, depending on the type to be made. All processes start by melting the solid pig iron in special furnaces.

*Gray-iron Castings.* The most widely used of all cast-iron forms, gray-iron castings are made entirely of pig iron, or of mixtures of pig iron and steel scrap, to which other elements are sometimes added. These castings are used in household articles, such as bathtubs, washbasins, and sinks, which are given an enamel coating. Gray-iron castings also find wide use in pipes, automobiles, locomotives, and light and heavy machinery.

*Chilled-iron Castings.* These are usually made by casting molten iron into metallic molds so that the iron cools and solidifies very quickly. Such iron castings are extremely hard on the surface and are used for rolls in rolling mills and in various other articles requiring a hard, wear-resisting surface.

*Alloyed Castings.* Varying amounts of certain alloys—such as nickel, chromium, silicon, and molybdenum—are contained in alloyed castings, which are used most extensively in the automobile industry.

*Malleable-iron Castings.* These castings differ from others in being ductile, or capable of withstanding a certain amount of manipulation without breaking. The first step in making malleable iron is to melt a special grade of pig iron with steel and foundry scrap. The molten iron is cast into sand molds. When solidified, the castings are given a *heat-treatment* in special furnaces. This renders the iron malleable, or workable.

Because malleable-iron castings can easily be machined and because they have strength and ductility, they are used principally in the automobile industry, although they are also valuable in the manufacture of farm machinery, parts of railroad cars, etc.

**How Castings Are Made.** The process of casting metal in sand is old and well known. Because it is adaptable to a product of large or complex form, this process makes possible shapes which cannot be made by any other manufacturing process. By means of it a great variety of shapes and forms can be produced.

Castings are obtained by means of impressions in sand of the

shape that is to be made. A *pattern* is used to make the desired impression, and the entire compacted sand forming the impression is called a *mold*. Patterns, though usually of wood, are, at times, made of metals. The latter is the common practice in large-scale production, where many similar parts are made from the same pattern. Patterns may be made in one piece or in two pieces, depending



Fig. 17-9. Cope being put on flask. (Whiting Corporation)

upon the shape of the part to be cast. For simple shapes and forms, a one-piece pattern is usually made; for those that are more intricate, the pattern may be of two or more parts.

The ordinary mold is made in a *flask* consisting of two parts: a lower, called the *drag*, and an upper one, called the *cope*. Figure 17-9 shows a molder putting the cope on the drag.

The usual procedure of the molder in the making of a simple mold is to place the drag on a molding board (a plain, straight board), fill it half full of molding sand, and then ram the sand down tight,



either by hand or by machine. When that is done, the pattern is placed in the correct position in the drag and the cope is placed directly over it. The cope is then filled up with more molding sand, which is rammed down tight. Figure 17-10 shows a flask just filled with sand.

After the necessary holes have been made through which the molten metal can be poured (the *gate*) and through which gases can



Fig. 17-10. Flask filled with molding sand (*Whiting Corporation*)

escape, the cope and the drag are parted, and the pattern is extracted. The cope and the drag are then placed together again, and the mold is ready to receive the molten metal.

It is important that the holes made for the escape of gases (called *ventholes*) should be placed in such positions as to make it possible for most or all of the gases to reach the surface. These gases must get out if the casting is to be good and strong. Gases that are allowed to remain in the mold after it cools will cause holes, known as *gas* or *blow*

holes, which tend to weaken the mold. One sure sign of a poor and weak casting is a large number of such holes.

### QUESTIONS ON THE PRODUCTION OF IRON

1. Define an iron ore. Name at least three such ores.
2. Name two factors that determine the value of an iron ore.
3. Name two ways in which iron ores are mined.
4. Explain the operation of a blast furnace.
5. What is the function of the coke in the refining process? of the limestone? of the hot blast?
6. What is meant by a charge?
7. What is slag? Name three uses for it.
8. What is cast iron?
9. Name and give two uses for other special iron castings.
10. Explain how a casting is made.
11. Why must the gases escape when the casting is cooling?
12. What is the result if the gases are not allowed to get out?

### STEELMAKING PROCESSES

Now that pig iron has been made in the blast furnace and is ready to be converted into steel, this is a good time to ask, "What is steel? How is it made?" Briefly, ordinary steel is an alloy of iron with carbon, which is malleable, in the form of a cast block or ingot. Such a steel is called a *plain carbon steel*.

As was stated earlier in this chapter, pig iron contains a number of elements, such as manganese, silicon, phosphorus, sulphur, and particularly carbon, in high enough proportions to make it very brittle. In the making of steel, these elements are largely burned out, or oxidized, from the iron; and the carbon is usually reduced to less than 1 per cent—sometimes to as little as 0.02 per cent. Pig iron, on the other hand, contains from 3.5 to 4.5 per cent of carbon.

Plain carbon steels, which constitute about 92 per cent of all the steel produced, have many thousands of uses in thousands of industries. Their contribution extends, literally, from tacks to giant castings for locomotives.

The remaining 8 per cent of steel production consists of *alloy* steels, which are explained later. These are steels having very

special qualities which enable them, severally, to withstand intense heat, cold, corrosive conditions, and unusual strains in service.

The three methods, or processes, for making steel in use today are the *bessemer*, the *open-hearth*, and the *electric* processes. These are the basic processes, and each will be explained in turn. Although there are one or two other methods for producing steel, the amount yielded by these other methods is so small that they are of little importance.

**Bessemer Process.** About one hundred years or so ago, when William Kelly, an ironmaster of Kentucky, was experimenting with a process of refining molten iron into steel by bubbling air through it, his friends thought he was wasting his time and money. They were confident that the air would chill and solidify the iron and, furthermore, they could not see how ordinary air would remove from the iron the impurities which would have to be removed if steel were to be produced.

They did not realize that the silicon, manganese, and carbon at the temperature of the molten iron (2300° F.) would burn when exposed to the oxygen in a blast of air and that, as they burned, the heat given off would not only maintain the temperature of the molten metal, but actually raise it from 300 to 500°.

Kelly did realize these facts, however, and almost at the same time, so did Henry Bessemer, an Englishman. Both men, working many thousand miles apart, independently developed a steel-refining process based on these principles—a process which transformed steel from a relatively expensive, little-used material, to a basic metal of civilization.

Bessemer was granted the original patents on the process in 1855; but Kelly, in 1857, proved that he had the process as early as 1847 and was, therefore, granted a patent because of the priority of his work. However, the two inventors merged in 1866 and the process was thereafter known as the *bessemer* process.

To start the converter operating, it is first turned on its side. Then liquid pig iron is poured into its mouth. The vessel is on its side so that the pig iron cannot run to the bottom and clog the air holes. As the vessel is tilted upright, the blast is turned on and the air rushes in through the nozzles in the bottom at the rate of 20,000 cu. ft. per min. under a pressure of about 20 lb. per sq. in. This

pressure holds up the metal in the converter and prevents it from dropping down. Figure 17-11 shows three views of the bessemer converter. The one at the right is a cross-sectional view showing the lining and the flow of air. The middle picture shows the "blowing" of the furnace. Here we witness the most spectacular sight in the steel industry. Sparks and flames belch from the open mouth of the converter. At first, brilliant sparks burst forth, followed by brown fumes and tongues of flame, which shows that the oxygen of the air

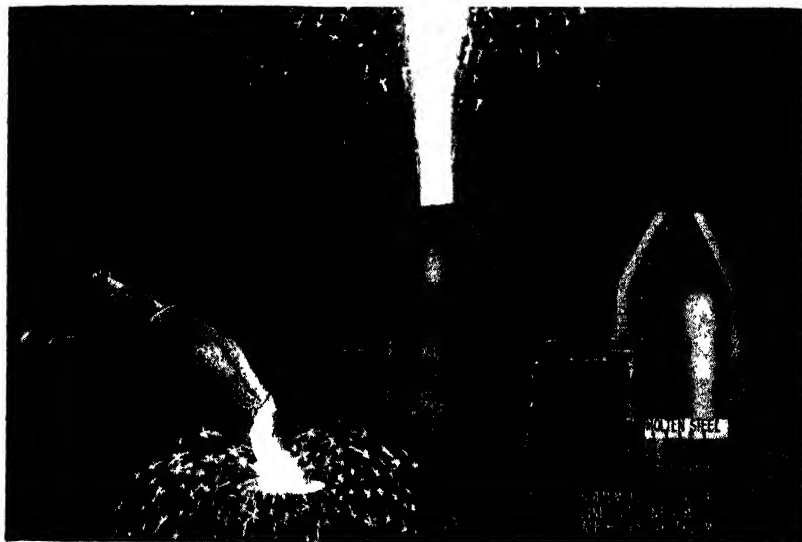


Fig. 17-11. Bessemer converter (*American Steel & Wire Company*)

is burning out the silicon and manganese impurities. Next, the flame becomes longer and intensely bright as the carbon burns.

After 12 or 15 min., the flames suddenly die down. The impurities have been burned out. The vessel is then tilted to a horizontal position, the air is turned off, and the steel is poured into a ladle (see view at the left). The necessary amounts of manganese and other elements are then added to give the steel the chemical composition desired.

Bessemer steel has certain definite advantages in the production of various steel products. For example, bessemer-steel wire will be

stiffer and harder than open-hearth steel wire drawn exactly in the same way. Bessemer-steel wire can also be drawn down to very fine sizes more readily than steel made by other processes, and for these reasons a great deal of fine wire is made from bessemer steel.

Bessemer steel is also free-machining. It can be cut or machined into various shapes with ease, because it contains more sulphur than ordinary open-hearth steel made without the deliberate addition of extra amounts of sulfur.

A third advantage of bessemer steel is the ease with which it is welded in the manufacture of pipe.

The bessemer method was at one time by far the most important steelmaking process, but to-day it is the least important. On account of increasing demands for "tailor-made" steels, which are readily produced by the more flexible and more easily controlled open-hearth and electric-furnace processes, the bessemer process is fast receding into the background in steel production.

**Open-hearth Process.** More than 90 per cent of all steel made today in this country is produced in open-hearth furnaces—rectangular, completely enclosed brick structures not unlike a kitchen oven in basic design and operation but built to operate at 3000° F., instead of at 550°, which is about maximum for a household oven.

The name *open-hearth* is applied because the hearth, or floor, of the furnace is exposed to the sweep of the flames which melt the steel. As Fig. 17-12 shows, the hearth is shaped like an elongated saucer.

The fuel, which may be natural or artificial gas, powdered coal, oil, or tar, or two or more in combination, is blown into the furnace through one of the large openings, or ports, located on each end of the furnace. To facilitate combustion, previously heated air is blown through the port, along with the fuel. Combustion occurs above the hearth and the smoke and other products of combustion escape through the ports at the other end of the furnace.

Beneath the furnace are two large chambers containing a checker-board arrangement of firebrick, through which air or gas will flow freely. As the hot products of combustion pass out through one of the ports and through the checkerwork they heat the bricks.

At the same time, the gas and air entering through the other side of the furnace are being heated by the bricks in the corresponding

checker chamber, which have previously been heated in the same way.

When the cold air and the gas cool the bricks to a point where they no longer give up enough heat, the direction of flow is reversed by valves, so that the chamber which has been heating the incoming fuel now becomes reheated by the products of combustion, and vice versa. Thus a great deal of heat is saved, and temperatures can be reached which would otherwise be impossible without great waste and the consumption of enormous amounts of fuel.

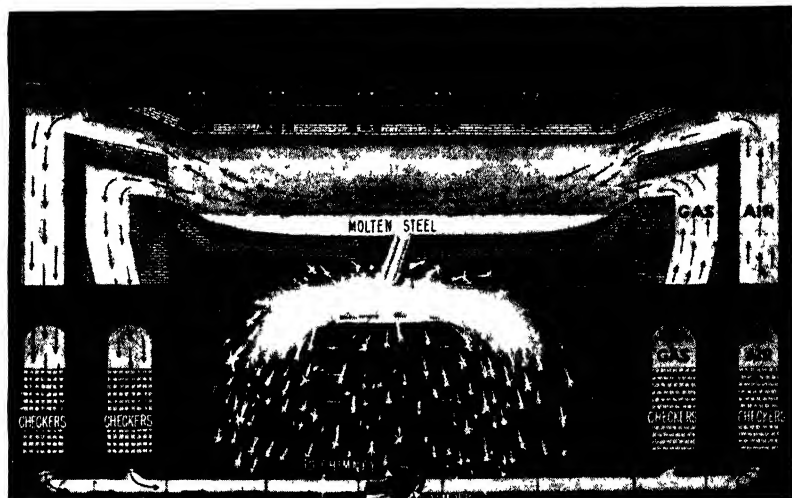


Fig. 17-12. Cross section of an open-hearth furnace. (*American Steel & Wire Company*)

When oil, tar, or pulverized coal is used as fuel, either alone or with gas, it is fed into the furnace through burners at each end. Only one burner is used at a time, so that the oil, tar, or coal will flow in the same direction as the air and the products of combustion.

An open-hearth furnace is, in effect, built on stilts, in order to provide for the checker chambers and to allow sufficient elevation so that molten steel will flow by gravity from the furnace into a ladle large enough to contain the entire contents of the furnace.

The charging floor, from which the raw materials are fed, is above the checker chambers and about level with the hearth. The doors,

which are mechanically operated, contain peepholes through which the melting operation can be observed.

Ores of less impurity than that used in the bessemer process are successfully made into fine steel by the open-hearth process by adding scrap steel and pig iron.

*Open-hearth "Pit."* The "pit" below the back wall, or pouring side, of the furnace may be 15 ft. or so below the charging-floor level. A spout through which molten steel flows from the furnace into the ladle, leads from a "tapping hole" in the exact center of the back wall. During the melting period the hole is plugged with heat-resisting clay, which is removed when pouring starts.

One of the basic elements in the design and construction of an open-hearth furnace (Fig. 17-12) is the refractory brick and other materials capable of resisting the high temperatures required to melt steel and the erosion caused by the boiling, molten mass. Hearth, walls, and roof of a single furnace may consist of upward of a million bricks of various kinds, some chosen for their strength, some for their ability to retain as much heat as possible within the furnace, and some because they will not disintegrate when held at high temperatures for a long time.

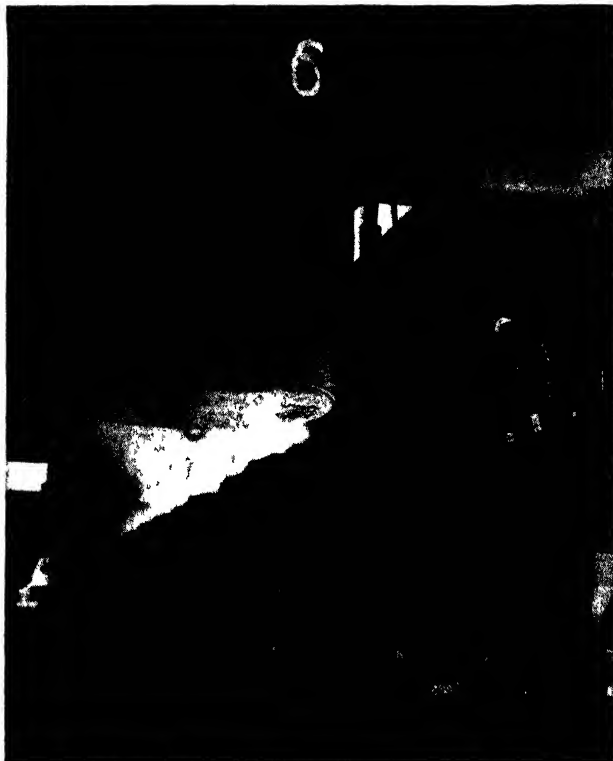
Open-hearth steel-melting operations are supervised by a "melter," who usually has charge of a battery of several furnaces. Assisting him are three highly skilled steel men, the first helper, the second helper, and the third helper, or "pitman," all of whom have accumulated vast funds of steelmaking knowledge during years of practical experience in the mills.

*What the Melter Does.* The melter, after receiving orders for the type of steel desired, determines the amounts of alloying elements to be added to each batch, or "heat," of steel, and arranges for the proper type of molds into which the steel is to be poured from the ladle. It is he who decides when the heat is ready, gives the order to tap, and superintends the pouring of the steel into the molds. After the heat has been tapped, he inspects the furnace and supervises any repairs he finds necessary.

The first helper operates the furnace and supervises any repairs necessary during melting, with the second helper and the pitman—both of whom have certain routine duties, as his assistants.

In addition to the melter and his three helpers, there are crane

operators on the charging floor and in the pit, and men who prepare molds and ladles for use; there are others who are experienced in pouring, or "teeming," the steel from the ladles to the molds. Among still others are additional crane operators who strip the molds from the ingots, and enginemmen and crews to operate the



**Fig. 17-13.** Pouring steel into ingot molds. (*American Iron & Steel Institute*)

small locomotives and trains which bring raw materials to the charging floor and haul the ingots from the pit to the rolling mills.

To make a heat of steel requires the combined skill and experience of many men, extensive equipment, and time—as much as 12 hours for a large heat.

*Case History of a Heat of Steel.* Figure 17-13 shows molten steel being poured from a 200-ton ladle in the open-hearth department of



a large steel mill into ingot molds. These molds can be plainly seen in Fig. 17-14.

**STEEL INGOTS.** "All steel begins in the ingot" is a traditional saying in the steel industry. It means that practically every steel product sold by the industry, whether tin plate, wire, or heavy girder, was at one time part of an ingot, the first solid form which steel takes. Ingots can be of many sizes and shapes, but in general they are large, rectangular shapes. A typical steel ingot made of open-hearth steel may weigh 5 tons, but bessemer and electric-furnace steels are usually cast into smaller ingots.

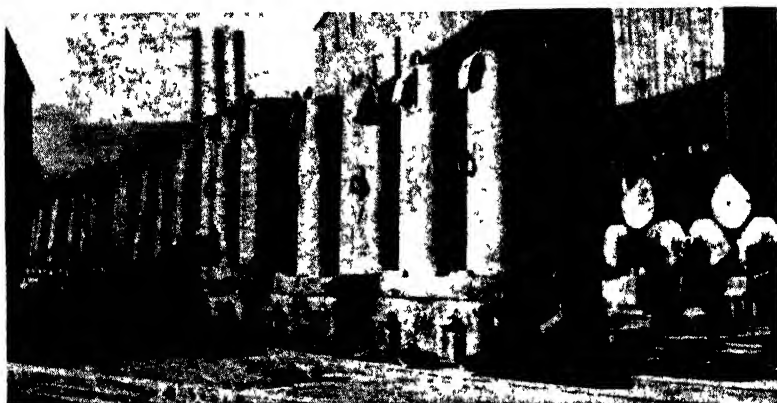


Fig. 17-14. Ingot molds (*American Iron & Steel Institute*)

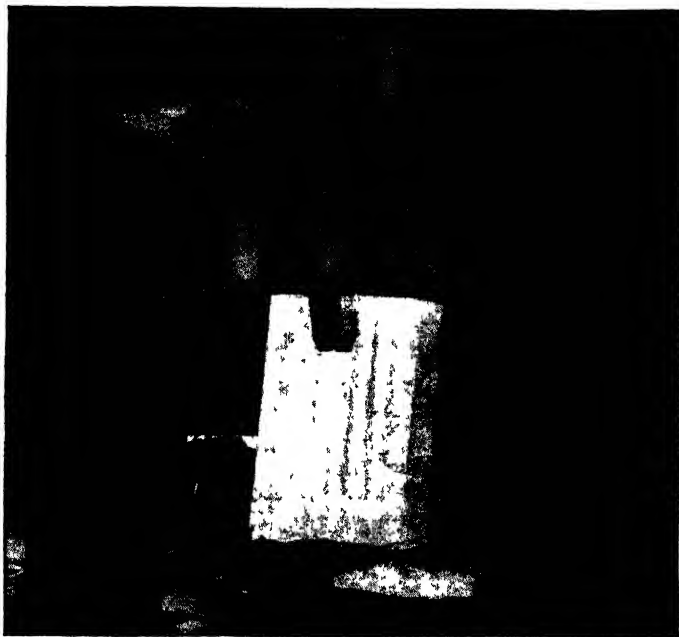
The molds are generally made of cast iron and are open at both ends. When they are ready to be filled, they rest on heavy, cast-iron plates, called *stools*, which in turn are mounted, as shown in Fig. 17-14, on small railroad cars for easy transportation to and from the steel department. Usually about 70 ingots can be cast in one mold before the mold can be scrapped and then used itself as part of the charge of an open-hearth furnace.

**SOAKING PITS.** Before the ingot can be rolled, it must be "soaked" in heat. The ingots are placed vertically in furnaces called *soaking pits*, where they remain until they are brought to a uniform temperature of about 2200° F. throughout.

When a suitable temperature is attained for rolling, the ingots are lifted from the pit by huge, crablike tongs. Figure 17-15 shows an

ingot being removed from the soaking pit by means of a special crane, which grips the ingot in much the same way as the familiar tongs of an iceman grip a block of ice. The ingot is now ready for rolling into various shapes.

**Electric Process.** When the first electric steelmaking furnace was built in this country, in 1906, it competed with and soon re-



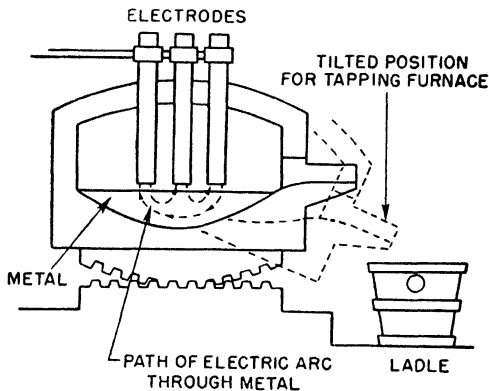
**Fig. 17-15.** White-hot ingot being drawn from the soaking pit. (*United States Steel Corporation*)

placed the crucible process as the principal medium for the production of high-grade alloy and tool steels.

The electric-furnace process is inherently more expensive in operation than any of the other modern steelmaking processes and, compared with that of an open-hearth furnace or a bessemer converter, the daily output of an electric furnace is small. The average open-hearth furnace can produce 225 tons of steel every 24 hours; the bessemer converter, about 2,800 tons; and the average electric furnace, between 30 and 40 tons. For these reasons, only the finest

grades of steel are produced by the electric-furnace method. About  $11\frac{1}{2}$  per cent of the steel made today in the United States is melted in electric furnaces, but its importance is far greater than the tonnage indicates. Figure 17-16 shows a diagram of an electric furnace.

Steels of the highest grades for use in aircraft, automobiles, bearings, magnets, many kinds of tools, engine valves, and innumerable other important manufactures are produced in electric furnaces. Stainless and heat-resisting steels—the aristocrats of steel—are made almost exclusively by that process.



**Fig. 17-16.** Diagram of an electric furnace. (*United States Steel Corporation*)

Electricity is used solely for the production of heat and does not of itself impart any mysterious properties to steel. Nevertheless, the electric-furnace method allows certain advantages impossible of attainment in other steel-melting processes. The electric furnace generates extremely high temperature (up to  $3500^{\circ}$  F.) very rapidly. The temperature is at all times under precise control and is easily regulated.

Furthermore, the production of heat by electricity is unique, in that oxygen is not necessary to support combustion, and the atmosphere within an electric furnace may be regulated at will. The quantity of oxygen entering the furnace can be precisely controlled which is not the case in the open-hearth and bessemer processes. Thus the presence of even minute quantities of oxygen, compounds of oxygen with other elements or other impurities undesirable in fine steels can

be materially reduced. In addition, the electric-furnace process permits the addition of expensive alloying elements to molten steel without loss by oxidation. For all these reasons, the metallurgist can control composition more closely and produce steel with fewer impurities in an electric furnace than in any other steelmaking furnace.

The body of the electric furnace is a circular steel shell resembling a huge teakettle in general appearance. It is mounted on rockers, so that the furnace can be tilted to pour off molten metal and slag. The bottom of the furnace is lined with refractory brick and other heat-resisting materials, to form a bowl-shaped container.

The side walls, which are also lined with refractory brick, contain three or more openings: a clay-lined spout for tapping off the molten metal and slag, and doors for charging the raw materials. The doors, which are operated mechanically, are, in some cases, water-cooled.

The roof of the furnace is lined with 9 in. or more of refractory brick and is shaped like a flat dome. Through this dome great columns of carbon reach into the furnace. These are the electrodes, which carry the current to the steel charge. They are commonly 17 in. or more in diameter and about 6 ft. long. The flow of current is regulated by raising and lowering the electrodes, each of which may be adjusted independently of the others. In general, the greater the distance between the electrodes and the charge, the less heat is produced.

The electrodes are spaced far enough apart so that no arc can occur between one and another. They project to within an inch of the layer of molten slag which floats on top of the steel and serves to prevent the intense heat of the arc from burning the steel. The slag also shields the metal from carbon vapors emitted by the electrodes.

The current jumps the gap between the electrode and the slag, passes from the slag into the metal, and is conducted through the metal and up to the foot of the next electrode, striking another arc. All the heat produced in the furnace is generated by the arcs.

Because the metal immediately below the electrodes is hotter than that near the walls of the furnace, the molten steel is in constant motion, as if it were boiling, and so is thoroughly mixed and uniformly heated.

Electric-furnace steel-melting operations are supervised by a melter. The usual crew of a 10-ton furnace consists of a melter and a helper; but in plants where more than one furnace is operated, it is common practice to place all the furnaces in charge of one melter. In that case each furnace is manned by a first helper and a second helper.

In addition to supervising the operation of the furnaces, the melter determines what quantity of alloys is to be added to the steel to meet specified analyses, and generally acts in an advisory capacity to the first helpers, who actually operate the furnaces. Second helpers assist first helpers in operating furnaces and weigh and charge the alloys which are used in making steel.

The manufacture of steels in electric furnaces depends largely upon the ability and good judgment of the men, for the furnace is simply a tool in their hands.

### QUESTIONS ON STEELMAKING PROCESSES

1. Name the three common methods of making steel.
2. Which one makes the finest steel? Why?
3. Give some uses for each type of steel made by the three methods.
4. Define slag. Has it any use? If so, name some.
5. Who were Kelly and Bessemer? What did each do for steel?
6. If iron ore is to be used as a basic metal in the charge, could it be used in the electric furnace? Why?
7. What is the importance of the melter in the steel plant?
8. Upon what principle of science does the electric furnace depend for heat?

### CHEMICAL NATURE OF STEEL

It is a well-known fact that pig iron contains at least five chemical elements, some of which lie between the grains, while the remainder will be found between the crystals of each grain. These five elements are *carbon*, *manganese*, *silicon*, *phosphorus*, and *sulfur*. Each one has a peculiar influence on the metal. While the iron is still in the molten state, the carbon lies in between the crystals and the grains, thus combining with the pure iron and causing the carbon to be known as *combined carbon*. Then as the metal cools and becomes solid, almost all the carbon frees itself from the crystals, moves outward, and

forms between the grains. It then is known as *free carbon*; but as it is of the nature of graphite, it is more often called *graphitic carbon*.

Manganese is to be found both between the grains and among the crystals. It unites with the sulfur and helps to remove that undesirable element. Some of the manganese also combines with the carbon between the crystals and makes the metal tougher.

Silicon lies between the crystals and not on the surface of the grains.

Phosphorus lies between the grains of the metal, and while it will make the iron flow freely, it also will make it brittle when cold and solid.

Sulfur lies between the grains and, as it has a bad effect on iron, it is always kept out of the metal as much as possible.

Each of these chemical elements has an important influence on the strength and other properties of iron and steel, and the amounts of these elements once established by the manufacturing processes cannot be changed without seriously affecting the nature of the metals. Such changes can be made by heat-treatment.

**Carbon in Steel.** Carbon is one of the most important elements of steel. Its influence on the strength of the metal is greater than that of any other element. For example, pure iron with no carbon has a tensile strength of about 10,000 lb. per sq. in. Put a little carbon in the metal, about 0.15 per cent, and the strength will be increased to about 55,000 lb. per sq. in. Add more carbon to about 1.00 per cent and the tensile strength jumps to about 100,000 lb. per sq. in. Therefore, the amount of carbon in steel largely determines the type of steel to which the metal belongs, as the following table shows:

Type of Steel	Percentage of Carbon
Low-carbon, machinery, or mild steel	0.10-0.30
Medium-carbon steel	0.30-0.60
High-carbon, or tool, steel	0.60-1.50

Carbon also largely determines the hardness and brittleness of steel. In low-carbon and medium-carbon steels, the amount of carbon is too small to have much hardening effect, but in high-carbon steels the carbon has a wonderful hardening action, which is usually obtained by the steel's being heated to a bright red and quenched quickly in cold water. This changes the nature of the carbon and

causes the metal to be *file hard*, so that it can be used to make cutting tools.

Carbon in steel will burn out of the metal if it is heated high enough and, of course, this would have an important effect on the steel. Any loss of carbon will lessen its tensile strength and hardness. Low-carbon steel has as one of its most important characteristics ductility—its bending, stretching, and forming qualities—a fact that machinists should not forget when working with this type of steel.

**Manganese in Steel.** Manganese is used in steel in different amounts according to the kind of steel desired, as may be seen by the following:

Kind of steel	Percentage of manganese	Characteristics
Carburizing steels	0.10–0.20	Ductility
High-speed steels	0.20–0.30	Toughness
Alloy steels	0.30–0.50	Toughness
High-carbon steels	0.60–0.00	Toughness

When used in ordinary low-carbon steels, and in steels that must be case-hardened or carburized, manganese makes the metal ductile and of good bending qualities. In high-speed steels, it is used to toughen the metal and to raise its critical temperature. This is true for alloy steels, as well.

**Silicon in Steel.** All steels contain silicon, but in amounts much less than that found in cast iron. For example, ordinary low-carbon steel contains about 0.20 per cent, while cast iron contains about 2.25 per cent of silicon. Silicon is put in low-carbon steels to prevent them from becoming porous and oxidizing. It removes the gases and oxides, prevents blowholes, and thereby makes the steel tougher and harder.

**Phosphorus in Steel.** This is an element that is undesirable in steel, but there is no known method for entirely eliminating it. Phosphorus makes steel brittle. It will affect the metal in such a way that, when it is black hot, cooling down from a red heat, if it is struck with a hammer, it will crack and crumble. This characteristic is called *cold-shortness*. The ductility of such steel is reduced, as well.

**Sulfur in Steel.** Another undesirable element of steel is sulfur. It affects the metal in such a way, when hot, that it cracks and roughens while being rolled or hammered. When heated to the red colors, as for forging, steel will show the presence of an excess of sulfur by a roughened surface, and the metal is then said to be *red-short*. Sulfur will also show its effects when the steel containing it is heated to the highest plastic temperature, not melted, by causing the metal to crack and roughen, and by preventing it from sticking together. This is called *hot-shortness*. In red-shortness, the sulfur causes crystallization of the steel, while in hot-shortness, the sulfur forms in a gas between the grains, causing a coarse, granular state. The percentage of sulfur should be kept as low as possible and never be more than 0.04 per cent in a good-quality steel.

**Alloy Steels.** In many cases, steels are needed that have a tensile strength, yield point, hardness, etc., that cannot be obtained in plain carbon steels. By the addition of such elements as nickel, chromium, molybdenum, vanadium, and others, steels of the low-carbon class may be hardened and will yield much stronger and more desirable types of steel.

An *alloy steel* may be defined as a steel to which elements other than carbon are added in sufficient amounts to impart desirable properties. To secure full advantage of these properties, alloy steels should be heat-treated.

There are so many different alloy steels on the market that it is very difficult for the tool designer and the machinist to make a selection that will satisfy his requirements. In many cases, alloy steels are used where a good plain carbon steel would equally satisfy the needs. Less alloy steel is used in automobile construction today than a few years ago. One reason for this is that steelmakers have learned how to control the product and to produce a better and more uniform carbon steel.

**The S.A.E. Numbering System.** As a result of the increasing demand for standard specifications for alloy steels in the automotive industry, the Society of Automotive Engineers (S.A.E.) has set up a series of specifications covering some of the alloy steels. These steels are designated by numbers in which the *first* figure refers to the type of alloy, the *next* figure refers to the approximate percentage of the predominating alloying element, and usually the *last two* figures refer



to the *points* of carbon present. One point of carbon equals 0.01 per cent. The figures referring to the type of steel are:

- |                  |                      |
|------------------|----------------------|
| 1. Carbon        | 5. Chromium          |
| 2. Nickel        | 6. Chromium-vanadium |
| 3. Nickel-chrome | 7. Tungsten          |
| 4. Molybdenum    | 8. Silicon-manganese |

This system is quite simple; for example, S.A.E. 1020 indicates a plain carbon steel of S.A.E. specifications, containing from 0.15 to 0.25 per cent carbon. S.A.E. 2340 indicates the following:

First number 2 indicates a nickel steel

Second number 3 indicates that it contains from 2.75 to 3.25 per cent of nickel

Third and fourth numbers indicate that the steel contains from 0.35 to 0.45 per cent carbon.

S.A.E. steels are also designated by five digits. For example, S.A.E. 10120 steel indicates that the

First number 1 = plain carbon steel

Second number 0 = no alloying elements

Third, fourth, and fifth numbers

120 = 1.2 per cent carbon

Another example of five digit S.A.E. steel is the S.A.E. 71360. This means that the

First number 7 = tungsten steel

Second and third numbers 1 and 3 = 13 per cent tungsten

Fourth and fifth numbers 60 = 0.6 per cent carbon

**The Effects of the Alloying Elements.** *Nickel.* One of the first alloy steels to be developed was nickel steel. Nickel increases the strength and toughness of the steel. These steels contain from 2 to 5 per cent nickel, and from 0.10 to 0.50 per cent carbon. In this range, nickel contributes great strength and hardness with high elastic limit, good ductility, and good resistance to corrosion. More recently, steels containing greater amounts of nickel—from 12 to 21 per cent, and about 0.10 per cent carbon—have been developed,

which have greater strength and toughness and extremely good resistance to corrosion. Such steels are at times called *stainless* steels.

*Chromium.* Chromium is used in steels as an alloying element to combine hardness, obtained by quenching, with high strength and high elastic limit. Chromium also imparts corrosion-resisting properties to steel. The most common chrome steels contain from 0.50 to 2.0 per cent chromium and from 0.10 to 1.50 per cent carbon. The special chrome steels of the stainless variety contain from 11 to 17 per cent chromium.

The greatest use of chromium steels is in the manufacture of high-grade balls, rollers, and races for bearings; armor-piercing projectiles, armor plate, etc. In a more limited degree, it is used for tools, dies, gears, safes, and vaults.

*Manganese.* Steel containing from 1.5 to 5 per cent manganese is very brittle and useless, but with from 7 to 19 per cent, the strength is increased. Manganese steel usually contains from 11 to 14 per cent manganese and from 0.8 to 1.5 per cent carbon and possesses a combination of extreme hardness and ductility.

The principal use of manganese steel is in machinery parts subject to severe wear, as in crushing and grinding machinery. Also it is extensively used in railroad equipment for frogs, switches, crossings, and curve rails. These are all cast and ground to finish.

*Tungsten.* Tungsten is usually used in conjunction with other elements in alloy steels. Steels containing from 3 to 18 per cent tungsten and from 0.2 to 1.5 per cent carbon are used for cutting tools. This is because they retain their hardness when hot.

The principal uses of tungsten steels are for cutting tools, dies, valves, taps, and permanent magnets.

*Molybdenum.* The action of molybdenum in tool steel is very similar to that of tungsten in changing the critical points, hardening power, and physical properties; and a given percentage of molybdenum can be used to replace an even larger percentage of tungsten. Molybdenum is used in connection with chromium in producing chrome-molybdenum (sometimes called *chrome-moly*) steels, which have very good strength properties, especially in undergoing repeated stress.

*Vanadium.* Vanadium, in amounts of less than 0.20 per cent, produces a marked increase in tensile strength and elastic limit in

low- and medium-carbon steels, without a loss of ductility. The structure of carbon-vanadium steels is finer than that of plain carbon steels.

Chrome-vanadium steels usually contain about 0.5 to 1.5 per cent of chromium, 0.15 to 0.30 per cent of vanadium, and 0.13 to 1.10 per cent of carbon. They have extremely good tensile strength, elastic limit, endurance limit, and ductility. These steels are used frequently for machinery. Castings; forgings; parts such as springs, shafting, gears, pins, steering knuckles; and many drop-forged parts are made of chrome-vanadium steel.

*Silicon.* Silicon steels contain from 1 to 2 per cent silicon and 0.1 to 0.4 per cent carbon, and very closely resemble nickel steels. These steels have a high elastic limit as compared to ordinary carbon steel.

Silicon steels, with varying amounts of silicon and other alloying elements, are used for electrical machinery, valves in internal-combustion engines, springs, and corrosion-resisting materials.

**High-speed Steel.** Until comparatively few years ago, all tools were made of high-carbon steel, that is, steel containing about 1.00 per cent carbon. This amount of carbon gave the steel great strength and hardness. When made into cutting tools, the steel would cut soft steel at a turning speed of about 20 ft. per min. Then a new steel was invented which, when used as a cutting tool, would cut soft steel about five times faster. For that reason the metal was called *high-speed steel*. It will cut metals from four to ten times faster than high-carbon steels, and it is so tough that its cutting edge will wear from five to ten times longer than the old steels.

A typical analysis of high-speed steel is as follows:

Element	Percentage
Carbon	0.67
Manganese	0.27
Silicon	0.23
Phosphorus	0.015
Sulfur	0.02
Tungsten	16.5
Chromium	4.3
Vanadium	0.82

The principal difference between the old high-carbon steel and the

new high-speed steel is in the addition of tungsten, chromium, and vanadium to the usual chemical composition of high-carbon steel, and in the reduction of carbon and manganese.

High-speed steel has three principal characteristics which were not found in steel before:

1. It is *air-hardening*, that is, if it is heated red hot and allowed to cool quickly in a blast of air, it will become very hard. This is quite different from ordinary high-carbon steel, which if allowed to cool in the air from a red heat, will become soft.

2. It possesses the characteristic of *red-shortness*, that is, it will maintain its cutting edge as a tool even when the pressure on the cutting edge is so great that the metal will become dark-red hot, a temperature of about 1000° F. An ordinary high-carbon-steel tool will become soft at such a temperature.

3. It possesses *tough-hardness* far beyond any other steel, that is, it is so tough that a tool made of it will maintain a sharp cutting edge while carrying a cut of metal ten times as long as the old steel, under pressures of many tons per square inch on the cutting edge, and at a rate of cutting so great that special provisions have to be made for the disposal of the chips.

### QUESTIONS ON THE CHEMICAL NATURE OF STEEL

1. What are the five chemical elements found in pig iron?
2. Define combined carbon; free carbon; graphitic carbon.
3. What effects has carbon in steel?
4. How does manganese affect carbon?
5. How does silicon affect steel?
6. How does phosphorus affect steel? Is it good or bad?
7. What are red-shortness and hot-shortness in steel? How are they caused?
8. Define alloy steels. Name some advantages and disadvantages of their use.
9. By what means may alloying elements bring about a change in the properties of steel?
10. Explain the S.A.E. numbering scheme of designating steels.
11. Explain fully the effect of the following elements on steel: nickel, chromium, manganese, vanadium, silicon.

12. If you use high-speed tool bits in your shop, ask the instructor for a high-carbon-steel tool bit and take cuts with each type. Write your impressions of the differences in cutting.
13. What is high-speed steel? Why is it so good in a cutting tool?
14. Will you have to sharpen such tool bits often? Why?
15. Describe the following alloy steels: S.A.E. 3567, S.A.E. 10235, S.A.E. 71345, S.A.E. 2345.

## Metallurgy, Properties, and Uses of Nonferrous Metals and Alloys

Nonferrous metals are the metals that contain little or no iron in their composition. They are, as a group, more or less noncorrosive and are nonmagnetic.

The nonferrous metals considered in this chapter are copper, tin, zinc, lead, bronze, brass, Babbitt, and aluminum. Alloys of these metals will also be described.

The metals and the alloys of this group have an important place in the machine shop. Many uses for these nonferrous metals have been found where other metals, especially those of the ferrous type, would be unsuitable. The aircraft industry makes extensive use of aluminum; the value of brass and bronze in marine engines and fixtures is well known.

As a rule, nonferrous metals are softer than the ferrous metals. This means that they are much easier to machine. Greater speeds and feeds are generally used in the cutting of such metals. Besides, glossy finishes are possible and quite easy to obtain—easier than on ferrous metals.

**Copper.** Copper is a rather heavy metal having a characteristic reddish color. It is relatively soft and is very malleable, ductile, and flexible, yet very tough and strong. A very efficient conductor of heat and electricity, being second only to silver, it is largely used in wire and sheet form for electrical purposes.

Copper is not found in a pure state in the earth. Being found as an ore, like iron, it has to be refined (smelted) so that the pure copper metal may be extracted.

Copper ores occur almost everywhere in the world. In this country, which produces about one-half of the world's supply, copper ores

are found in Arizona, Montana, Utah, and the Lake Superior region. They are in the form of *sulfides* of copper; that is, the copper is combined with sulfur to form the ore and is called *copper sulfide*.

Copper is noncorrosive under ordinary conditions and resists the weather very effectively. In moist air, the metal slowly becomes covered with a film of bright-red oxide, which in turn changes to a green basic carbonate. This gives it the familiar tarnished red-green color so frequently noticed on outdoor work, such as cornices and rain spouts. Hydrochloric acid, diluted sulfuric acid, and some alkalies have practically no effect on it. Nitric acid and hot concentrated sulfuric acid, however, readily dissolve it.

Because of its relative softness, commercially pure copper does not hold an extensive place in the manufacture of piece parts. It is more frequently used in the alloyed state, in such metals as brass and bronze. Deep-drawn cans, rivets, and some parts used in electrical units, where high electrical conductivity is required, such as knife switches, are examples.

The metal does not machine too well because of its softness and the "gummy" way it resists cutting action. The chips from drilling cling to the drill so that the tool must be cleared of chips frequently. Drilling deep holes is very troublesome. In tapping, the material has a tendency to build up in the flutes of the tap and, unless it is carefully done, tapping frequently causes tool breakage. For best results, holes for tapping should be drilled oversize.

Milling and sawing actions heat the work quickly and, unless the chip clearance is ample and large quantities of cooling lubricants are used to cool and clear the chips, trouble is experienced. Besides, large burrs are met with.

Surface speeds up to about 200 ft. per min. are recommended for machining copper with a relatively light cut. Because cuts and scratches made by copper chips are dangerous, possibly causing infections, they should receive proper care immediately.

Copper draws exceptionally well, and drawn-copper wire only a few thousandths of an inch in diameter is very common. Cans and similarly drawn and spun parts can frequently be made in fewer operations than they could be produced from other metals. Working the metal hardens it to a certain extent, and annealing is required where the working is excessive. Annealing is usually done at a tem-

perature of about 1200° F. The parts may be quenched in water when hot, as this has no effect on the annealing process. Annealing, however, oxidizes the surface of the metal, which should be removed before further working takes place, as this black scale is injurious to tools. Nitric-hydrochloric and nitric-sulfuric acid solutions are used for this purpose.

Here are some facts about copper that may be interesting to the apprentice.

Specific gravity	8.9
Weight	556 lb. per cu. ft.
Tensile strength	24,000 lb. per sq. in.
Compression	40,000 lb. per sq. in.
Melting point	1940° F.

**Tin.** Tin is a brilliant white metal with a yellowish tinge. Soft, malleable, and ductile, it can be rolled into very thin sheets; and because it does not corrode in wet or dry climates it is useful as a protective coating for iron and steel. Tin plate, for example, is extensively used for cans and containers. In the sheet form, it is frequently made into tank linings.

The principal ore of tin is in the form of an oxide (tin combined with oxygen) and is found in England, Malaya, and Bolivia. The ore has to be refined in order to produce the pure tin. However, there are some impurities left after refining which do not have any marked effect on the metal.

Here are some interesting facts about tin:

Specific gravity	7.29
Weight	455 lb. per cu. ft.
Tensile strength	3500 lb. per sq. in.
Compression	6000 lb. per sq. in.
Melting point	450° F.

**Zinc.** Zinc is a bluish-white metal with a very crystalline structure. Because of this structure, it cannot be worked extensively, for example, in the way of drawing or forming. It can be cast readily and is used for ornamental and model castings, but probably its principal use is as a protector for other metals, because it does not corrode. The common application is that of zinc plating and galvanizing.



The principal ores of zinc are found as sulfides and carbonates (zinc combined with carbon and oxygen).

Here are some facts about zinc:

Specific gravity	7.29
Tensile strength	5000 lb. per sq. in.
Compression	20,000 lb. per sq. in.
Melting point	787° F.

**Lead.** Lead is a soft, heavy metal that has a white, bright color when freshly cut but quickly turns to a dull gray when exposed to air. One of the softest of the common metals, it oxidizes very slightly in moisture and resists the action of dilute hydrochloric and sulfuric acid. Therefore, it is extensively used for water pipes, acid-container linings, and similar corrosion-resisting products.

The only important lead ore is *galena*, which is a sulfide of lead. It is found in abundance in this country and has to be refined to extract the pure metal.

Lead is very malleable and ductile and can be rolled or hammered with little change. It alloys readily with other metals and, in combination with tin and antimony, is used to make pewter, type metal, solder, etc. The chief use of lead is in the production of lead-covered cables, especially for the electrical industry.

Here are some facts about lead:

Specific gravity	11.37
Weight	710 lb. per cu. ft.
Tensile strength	2000 lb. per sq. in.
Melting point	621° F.

**Aluminum.** Aluminum is a white, comparatively soft metal that is extensively used where a light noncorrosive metal is desired. The favorable quality of aluminum is that it is very light in weight as compared to other metals, yet it is stiff and strong.

Aluminum is derived from an ore called *bauxite*, an aluminum oxide which is found in Hungary, in Italy, and in this country. Arkansas is especially noted for this ore.

Aluminum ordinarily is not used in the pure form but is alloyed with other metals, to increase its strength and stiffness, while still retaining its light weight. Because of alloying, the strength, specific

gravity, hardness, and melting point change considerably. Manufacturers of this material furnish complete data on their products as to the best uses, and they should be consulted for specific information.

Aluminum may be blanked, formed, drawn, turned, cast, forged, and die-cast. It may be spun, as well. In fact, it can be processed by almost any of the common machining processes. Satisfactory working, however, depends entirely on the composition and the temper, or hardness, of the material. There are two general classes manufactured—one in which the degree of hardness, or temper, is produced by cold-working and rolling, and the other in which the strength and hardness are obtained by special heat-treatment.

Aluminum in general is easily machined and surface speeds up to 1,000 ft. per min. are recommended. Milling cutters must be very sharp for best results. Drilling varies with the type of material. Castings, for example, drill easily with ordinary drills, but on bars of the drawn kind, the action is that the material is clingy and that excessive burrs are experienced. Special drills and drills ground similar to a wood bore work very well. High speeds and fine cuts work best on this material.

For blanking, the tool must be sharp and close-fitting, otherwise excessive burrs, which are not easily removed, result. Tools for cutting and blanking aluminum hold their edges fairly long.

For forming and drawing, the softer varieties of aluminum must be used for best results. Deep and light cans and containers are some of the favorable products. Spinning is also very successful and this method finds considerable application in the making of cooking utensils.

Aluminum is noncorrosive and, under ordinary conditions, water and air have practically no effect on it. Soda-ash and alkaline products, however, attack it readily, and objects made from aluminum should not be washed with such products. Hydrochloric acid also acts upon it. Nitric acid and dilute sulfuric acid, on the other hand, have practically no effect on the metal. For this reason, aluminum baskets are extensively used for acid-dipping brass and similar parts.

The soldering of aluminum is not very successful. It may, however, be welded. The metal is nonmagnetic, but it has a high electrical conductivity, although not so high as that of copper. It heats

freely. Because in handling the material scratches and distorts easily, it should be handled carefully.

Here are some facts about aluminum:

Specific gravity	2.70
Weight	166 lb. per cu. ft.
Tensile strength	15,000 lb. per sq. in.
Melting point	659° F.

**Bronze.** Bronze is a metal composed mainly of copper, zinc, and tin. The metal is comparatively hard and particularly resists surface wear. Because of this, it is used extensively for machine bearings. Other elements, such as phosphorus, aluminum, manganese, and lead, are alloyed with the metal to produce certain characteristics more favorable to the particular uses to which the metal is to be put. Machine bearings must perform under various conditions as, for example, the bearings of a punch press, where the speed is relatively low but the pressure is very high, especially during the moment of shock when the cutting or forming is actually being done. And again, other machines are hard to oil or the lubricant may affect the product being worked on. To meet these conditions the various types of bronzes have been developed.

With the exception of phosphor bronze, most bronze materials are used in the cast form, either as a specific casting or in precast bar or tubular form, from which the bearings are machined. Phosphor bronze is also made extensively in rod and sheet form. The rods are used chiefly for small bushings, rollers, etc., and the sheet stock for contact springs and similar electrical units in which considerable frictional wear is experienced.

The cast metal does not, as a rule, machine very well. The outer surface of the castings has a glasslike structure which removes the cutting edge on tools very quickly, and high-speed-steel tools must generally be used. In such operations as boring, the tools have a tendency to back away from the metal and, unless hard and sharp tools are used, it is difficult to turn or bore a good surface on some of the bronzes. The grinding of the tools will vary with the types of materials, although, in general, lathe tools with no back rake and with considerable clearance work best. In drilling some bronzes, drills work best with the sharp lip removed, while others work just as well with the standard grinding.

Like copper, bronze is noncorrosive, this characteristic varying somewhat with the composition of the bronze.

Some of the more common types of bronze and the special purposes for which they are used are given in the following paragraphs.

*Bearing Bronze.* This bronze is used chiefly for bearings where high speed and moderate pressure are the working requirements. It contains about 70 per cent copper, 26 per cent lead, and 4 per cent tin. It has a tensile strength of about 18,000 lb. per sq. in. and a compression strength of about 12,000 lb. per sq. in.

*Phosphor Bronze.* Phosphor bronze has a small amount of phosphorus added to it, and this gives it greater strength and ductility than other simple bronze alloys possess. It can be cast, rolled, drawn cold, and forged, and it is used for all average bearings in which wearing qualities are desired. Pump parts, linings, and propellers are examples of the use of cast manufacture. In the sheet form, its high elasticity makes it especially suitable for springs. Resistance to salt-water corrosion makes it applicable to boat propellers.

It has a specific gravity of 8.7, weighs 514 lb. per cu. ft., has a tensile strength of 60,000 lb. per sq. in., and a melting point of 1760° F.

*Manganese Bronze.* A small amount of manganese is added to the copper, zinc, and tin, to make bronze of this type. It is stronger and tougher than phosphor bronze. It also has a high corrosion resistance. Worm gears are frequently made from this bronze, and it is also used in preference to aluminum bronze in many cases because it is more easily handled in foundry work and produces better castings.

*Tobin Bronze.* Tobin bronze contains 59 to 63 per cent copper, 0.05 to 1.5 per cent tin, and the remainder zinc. It is also highly non-corrosive and is not likely to throw sparks, under frictional contact. It is chiefly used for high-grade bushings and sleeves and bearings in contact with water.

*Naval Bronze or Brass.* Naval bronze or brass is composed of 62 per cent copper, 37 per cent zinc, and 1 per cent tin, and is very similar to Tobin bronze in content. It is the general mixture used for ordinary castings, such as handwheels, brackets, and frames.

**Brass.** Brass is basically an alloy of copper and zinc. In the commercial product there are many variations in the metal, as it is

alloyed in varying percentages of copper, zinc, and lead to obtain specific results. Small amounts of iron and other impurities are also contained in the metal. The color is normally a bright yellow, but shades from bright gold to a copper are found in it, depending on the percentages of copper, zinc, and other elements present.

The metal is noncorrosive, and air, water, and some acids do not appreciably affect it. Sulfuric acid, however, attacks it readily and is one of the agents used in the process of acid-dipping to give parts made from brass a high luster. One of the main applications of brass in manufacture is due to its noncorrosive nature. The metal is easily machined and is nonmagnetic. It is a poor conductor of electricity. Under certain conditions copper salts form on the metal, which are highly poisonous, especially to open cuts. All injuries should be protected from brass chips, and any scratches made with the metal on the hands or other parts of the body should receive medical attention immediately.

Brass may be rolled, cast, drawn, formed, and turned with little difficulty and is often used in place of other less expensive metals because of its free-working features. For each purpose, a specific mixture or alloy works best, however, and it is important that the right grade be used.

Forming, bending, and drawing operations all have a hardening effect on brass. Frequently brass parts must be annealed before a drawing or forming operation can be done. Deep-drawn cans are an example. To permit drawing to a maximum depth in the first operation and reduce the number of draws required as much as possible, a very soft grade of brass is used at the start. The resulting product would be hard and brittle and, if further drawing were attempted, excessive breaking would occur. The product must, therefore, be properly annealed by being heated to approximately 1100° to 1200° F. to soften the metal, or *normalize* it, to use another term applied to the process. The annealing process oxidizes the surface of the metal and a black scale is formed. This scale, or oxidation, causes rapid wearing of the tools used and should be removed. As a rule, hydrochloric acid is used for this purpose.

Brass parts heated for annealing may be quenched in water to cool them and thus speed up the operation. The quenching has no effect on brass.

The physical properties of brass vary with the composition, and the tensile strength ranges from 45,000 to 100,000 lb. per sq. in. For ordinary calculations, however, the following figures are accepted:

Specific gravity	8.41
Weight	523 lb. per cu. ft.
Melting point	1750° F.

**Babbitt.** Babbitt is an alloy of tin and copper, containing a small amount of antimony. It is the most common bearing metal used with cast-iron boxes. The metal, which casts easily, is usually poured between the cast frame and the shaft bearing and, after cooling, the working surface is finished by having the excess metal scraped away. The use of Babbitt has the advantage that, when the bearing is worn, the old Babbitt may be removed and a new bearing may be cast. For moderate speeds and load, Babbitt makes a fine bearing and does not score the shaft very easily when the lubricant fails.

There are many babbitting mixtures used, each varying slightly in the composition.

**Monel Metal.** Monel metal is an alloy of 60 per cent nickel, 38 per cent copper, and a small amount of manganese or aluminum. A white, tough metal that is ductile and can be readily machined, it is made in rods, sheets, wire, and tubing, and may be forged and cast. It welds readily and the clean surfaces solder and braze without difficulty. High-speed tools with sharp cutting angles work best, and high speeds with light cuts give the best results.

Monel metal resists corrosion and may be used wherever this characteristic, combined with strength and hardness, is desirable. Valves, studs, and bolts are examples.

**Duralumin.** Duralumin is an alloy of aluminum having, in addition to the aluminum, 3.5 to 4 per cent copper; 0.5 to 0.75 per cent manganese; 0.5 to 1.00 per cent magnesium; and less than 0.60 per cent of silicon and of iron. The material is comparatively hard and stiff and has considerable use in light metal framework. It weighs approximately one-third as much as steel and has, therefore, been used extensively in airplane and dirigible-balloon construction.

Duralumin comes in various shapes and sections, such as angles, tubes, and special drawn shapes. Frameworks for large broadcasting-apparatus units are frequently made of this metal. The material is also rolled in sheet form.

Duralumin machines readily, and high speeds and feeds are used. About 500 or 600 ft. surface speed may be used. Keen-edge tools are best in cutting. The chips do not drag on the tools as badly as some other aluminum alloys and it is, therefore, well suited for screw machines and lathe work.

**QUESTIONS ON THE METALLURGY,  
PROPERTIES, AND USES OF  
NONFERROUS METALS AND ALLOYS**

1. Define a nonferrous metal. Name five.
2. Name five properties of copper in its favor.
3. Name five uses of copper in industry.
4. How should copper be drilled? milled.
5. What precautions should be taken when one is scratched or cut by copper chips?
6. What is the chief use of tin?
7. Name five uses of lead.
8. Where is aluminum used? Name at least three major industries using this metal in their manufacturing processes.
9. How does aluminum occur in nature? Name the ore.
10. How should aluminum be machined?
11. What is meant by bronze?
12. Name five uses of bronze.
13. How is bronze usually machined?
14. Name three different types of bronze. Name at least two uses of each.
15. What is brass?
16. Name four physical properties of brass.
17. Name three uses of brass.
18. What is Babbitt? What is its chief use?
19. What is Monel metal? Name three uses.
20. What is duralumin? Name three uses.

## Heat-treatment of Steel

Many centuries ago men knew that heating and cooling iron and steel radically changed their properties. The Egyptians must have known this because the building of obelisks and statues involved the use of hard-steel cutting tools. The village blacksmith beating out a chisel on his anvil knew that the metal became harder when he suddenly plunged it, or quenched it, in water.

It was not until the microscope revealed the inner structure of steel that men were able to observe the changes that take place as a result of heating and cooling metals. It was found that these internal changes obey definite laws. The processes used to bring about these changes through heating and cooling are called *heat-treatment*.

The first step in preparing steel for its many uses is to obtain the exact chemical composition of the steel. The second step is to shape the steel into the desired form. The third and final step, for many purposes, is heat-treatment. Few steels can be given their highest possible development for particular purposes without some form of heat-treatment.

To understand the need of heat-treatment, it is helpful to know that steel is a combination of many elements, in an arrangement that can be changed in various ways. This internal arrangement is radically changed, and the properties of the steel itself are changed, by operations in the mills, such as rolling, wire drawing, heating, and cooling. The study of the microscopic structure of metals and alloys is called *metallography*.

Heat-treatment falls into two main divisions. The first involves no change in the composition of the steel, and the second involves a change in the surface of the steel through the absorption of carbon, nitrogen, or carbon and nitrogen.



In the first division, the principal forms of heat-treatment are *normalizing*, *annealing*, *hardening*, and *tempering*. Each will be explained, but greater detail will be given for the processes of *hardening* and *tempering* than for the other two. *Casehardening*, the second division of heat-treatment, will also be discussed.

**Normalizing.** Normalizing is one of the simplest forms of heat-treatment. As the name indicates, it is used to restore to "normal," by heating, the structure of the steel after cold-rolling. It may be applied to castings and forgings, as well as to various rolled products, and it is done by heating the steel to a specified temperature and cooling it in the air.

**Annealing.** Annealing is a carefully controlled form of heat-treatment. Its chief purpose is to soften the steel by relieving internal stresses caused by rolling and wire drawing, which tend to make the steel hard. In the case of wire, annealing produces a certain pliability. Notice sometimes how wire may be twisted or bent without breaking. Another use of annealing is to soften some steels so that they may be more easily machined. The annealing operation consists of heating the steel in an annealing furnace to a definite temperature, holding the temperature steady for a given time, and then allowing the steel to cool slowly at atmospheric temperature in the furnace, ashes, lime, etc.

**Hardening and Tempering—Theory.** Since the machinist must know how to harden and temper high-carbon steel (tool steel), a few words of explanation of *carbon in iron* should be interesting and helpful to the beginner in machine-shop practice.

Carbon will chemically combine with iron; that is, it will dissolve in the iron and form a new substance, carbide of iron or iron carbide (either name can be used). This carbide of iron is called *cementite*. The chemical formula is  $\text{Fe}_3\text{C}$  (three atoms of iron and one atom of carbon). Every piece of steel contains its proportion of carbon in the form of cementite, in a matrix of iron. It is in the form of cementite that carbon is made into a *solid solution* with iron, to produce steel. In other words, (1) the carbon in steel is *chemically combined* with some of the iron to form molecules of *cementite*, and (2) the minute crystals of cementite are intimately mixed in the mass, as it cools from the molten state, and form a solid solution with the rest of the iron.

Under the microscope the structure of the steel slowly cooled from a high temperature (red heat) appears to be made of one or, at most, two of three different particles or crystals. They are ferrite, cementite, and pearlite.

*Ferrite* is pure iron, named from the Latin word *ferrum*.

*Cementite* is the iron carbide  $\text{Fe}_3\text{C}$ .

*Pearlite* is the name given to the *saturated* mixture of ferrite and cementite. It is, in fact, the mixture of cementite in iron that will give 0.90 per cent (nine-tenths of 1 per cent) by *weight* carbon in iron. When the steel has under 0.90 per cent (90-point) carbon, the particles are in the form of microscopic layers of *ferrite* and pearlite, because there is not enough cementite to saturate the iron. When over 90-point, the particles are in layers of *cementite* and pearlite because there is too much cementite to be perfectly mixed. And when the steel is just 90-point carbon content it is composed entirely of *pearlite*, because the proportion of ferrite and cementite is right. Steel with 0.90 per cent carbon, the saturation mixture, is known as a *eutectoid*, under 0.90 per cent as *hypoeutectoid*, and over 0.90 per cent as *hypereutectoid*.

In the short discussion that follows, only steel of around 0.90 per cent carbon, the so-called *carbon tool steel*, or merely "tool steel," will be considered.

When a piece of tool steel is gradually heated, there will suddenly (at about 1350°F.) occur a distinct change in the appearance of the steel—"the shadows disappear." With proper instruments a *drop* in the temperature may be recorded. At this time a very wonderful change has taken place in the steel; the *structure* is different. The temperature at the time of the change is called the *decalescence point*. If the steel is heated above the decalescence point and slowly cooled, the reverse change takes place, and a slight *rise* in the temperature may be noted. This is called the *recalescence point*.

(In steel having less than 90-point carbon, one, and in the case of low-carbon steel (below 30-point carbon), two similar changes occur before the decalescence point is reached. The temperatures at which they take place are known as the *critical points*, and the temperature range between the points is called the *critical range*.)

It is at the decalescence point, or a little above, that tool steel

should be quenched to produce, in the hardened steel, the smallest grain size and the maximum hardness.

When tool steel has been heated to the decalescence point or slightly above, the normal structure (pearlite, mostly) has been *transformed* to another state, or structure element, which is called *austenite*. This is defined as the solid solution of iron and carbon as it exists above the transformation point (decalescence point), or as it is *set* by rapid cooling, or *preserved* by the presence of a *retarding element*, as in 12 per cent manganese steel. It is impossible to set more than a small part of the mass of red-hot steel, as it is quenched, in the form of austenite; there are, in fact, several other structures in the piece of hardened steel. The names, besides austenite, that have been given to these definite structures are: *martensite*, which is the principal structure element in very hard steel; *troostite*, which is the transition structure element next to martensite; and *sorbite*, which is softer than troostite. From sorbite the structure of the steel changes, as it cools gradually, to the original pearlite. It will be clear that, if the steel is suddenly cooled, or *retarded* by some agent like manganese, and is not allowed to change back slowly to pearlite, then the structure (hardness) will depend upon whether martensite, troostite, or sorbite was preserved.

The above is interesting as containing the theory of tempering steel. When hardened steel is reheated, the changes back toward pearlite that were retarded (set) by quenching are caused to take place. That is, the structure changes from austenite-martensite through the other structures or it may be stopped when at the desired physical condition. This is called *tempering* the steel. Tempering reduces the brittleness and makes the steel tougher, in proportion to the degree of heat used. Incidentally, some of the hardness is sacrificed.

Briefly stated, hardening a piece of steel is the process of heating it thoroughly to or a little above the decalescence point, quenching it in a suitable bath, on the ascending heat if possible, and thus setting or trapping the steel in the austenitic-martensitic condition or structure. Tempering a piece of hardened steel is the process of reheating the steel to have the combination of martensite-troostite-sorbite which will give the degree of toughness required.

Steel, then, is an alloy of iron and carbon. The carbon content is

usually not over 1.40 per cent (140-point)—high-carbon “razor-temper” steel, and may be as low as 0.10 per cent (10-point)—“dead-soft” steel. The nearer pure iron the steel is, the softer it is, the more easily it forges and welds, and the more readily it machines. Consequently, 10- to 20-point carbon steel (dead soft) is used for making chains, rivets, etc., and 20- to 35-point, being stronger, yet machining easily, is used for bolts, shafting, etc.

Steel between 30 and 70 points is used for heavy forgings in engine work and for car axles, rails, etc.

Steel over 75-point (0.75 per cent) carbon content may be hardened and tempered.

**Machine Steel and Carbon Tool Steel.** Steel under 50-point carbon does not harden perceptibly and is called “low-carbon,” or “mild” or “machine” steel. Steel over 75 point will harden and is called “high-carbon,” or “tool,” steel and to differentiate it from the “high-speed” steels, which will presently be referred to, it is often called “carbon tool steel.” While the 75-point steel will harden and is suitable for hammers, crowbars, etc., it is not suitable for the cutting tools used in machine shops. Steel for drills, taps, reamers, etc., requires more carbon, and the best carbon tool steel for cutting tools has a carbon content of from 90 to 100 points. Steel of substantially 100-point carbon is used for drill-rod and spring steel; for punches and dies; for hacksaws and files, etc. Steel, when heated, is changed in its structure and in its properties. Steel of around 100-point carbon, when heated to a temperature ranging from 1375 to 1400° F., attains the finest structure (grain size) which it can have, and, if quenched in cold water the moment it has attained this heat, it is trapped in this perfect structure and in a condition of extreme hardness.

When the steel is reheated sufficiently (about 400° F.), a noticeable change begins to take place in the quality of hardness, and when it is heated some 600° F. the steel has lost all its brittleness and most of its hardness. That is to say, carbon tool steel changes from glassy hard to practically soft—the whole range of temper takes place—between the temperatures of 400 to 600°.

**The Hardening Heat.** If steel is not heated enough, it will not harden; if overheated, it is injured; if very much overheated, it is ruined. The proper temperature is determined largely by the carbon

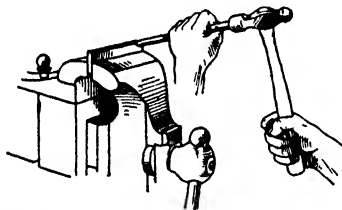
content: the less carbon, the greater heat. For instance, a hammer made of 75-point carbon steel will require 1425 to 1450° F. while a reamer made of 100-point carbon steel requires less heat (1350 to 1400° F.) and will be injured if heated to 1450° F.

*Metcalf's Experiment.* To show the effect of different degrees of heat on the strength, appearance, and hardness of the heated and quenched tool steel, take a piece of steel about  $\frac{1}{2}$  in. in diameter and 6 or 7 in. long, and with a pointed tool, cut shallow grooves



Fig. 19-1. Test bar for Metcalf's experiment.

$\frac{1}{2}$  in. or so apart and number the sections (Fig. 19-1). Put one end of the piece in the fire and allow it to get white hot (very much overheated) before the other end is hot enough to harden at all. Plunge it into water and, after thoroughly drying it break off as many sections as are necessary to show: (1) that the overheated end is weak—



breaks easily—and the grain is very coarse; (2) that as succeeding pieces are broken the blow necessary to break them is increasingly greater, and the grain size is finer; (3) that the end insufficiently heated is not hard—it may be easily filed (use the corner of a wornout file for testing the hardness); (4) that in the sections along the center portion the greatest hardness and the greatest strength (resistance to the blow) are

accompanied by an uneven structure and the finest grain.

Metcalf's experiment may be made more quickly by using a strip of tool steel—say,  $\frac{1}{8}$  in. by 1 in. by 5 in. Overheat one end while the other end is occasionally dipped in water to keep it from getting even a low red heat. When the hot end is *white hot*, dip the whole piece in water until cold. Reheat carefully just enough to melt solder. Now catch the piece in a vise, in order to break it in two *lengthwise* (see Fig. 19-2). With the upper half projecting above the vise, break off about two-thirds of the length and bend the rest a

little. The broken edge should give a complete picture, showing the overheated enlarged grain, the perfectly heated close grain, and the underheated unhardened part that bends and does not break. The overheated end breaks much more easily than the properly heated part.

At the moment a piece of steel is exactly the right heat for hardening, a change takes place in the structure. It is not difficult for the beginner to gage this proper heat quite closely if the heating is fairly slow and uniform, because at this moment the darker portions of the mass fade into a uniform red heat. Try heating any small piece of steel—for example, the unhardened part of the experimental piece—and notice this change. The corners may appear hot enough (be careful, don't heat too fast, don't let the corners get too hot) while the rest of the piece appears a darker red. Soon, however, the whole piece assumes an even heat and then is the time to quench it. That is, quench it "when the shadows disappear."

### **HINTS ON HARDENING**

1. Heat the piece slowly, thoroughly, and evenly; otherwise it is liable, when quenched, to be soft in spots, or warped, or possibly cracked.

2. Do not overheat the steel or it will not hold an edge. If by any chance it is overheated, do not hold it until it looks about right and then quench it; this will do no good. It will be much better to allow the steel to cool, then reheat it to the proper temperature and quench. If a piece is much overheated, the surface is blistered. Such a surface is permanently ruined.

3. Do not use the fire hotter than necessary; else the corners or thin sections will heat too quickly—before the rest of the piece is hot enough.

4. Do not lay a long, slender piece so that it can bend of its own weight when heating, or it will be bent when hardened.

5. Quenching should be done on the ascending heat. Remove the work from the fire to the quenching bath as quickly as possible.

6. Quench the long work lengthwise and the flat work edgewise, to avoid warping. If the sections of the work vary greatly in size, quench the large section first, to avoid cracking.

7. To avoid soft spots, keep the piece moving in the quenching bath, thus keeping it in constant contact with the cold bath and away from the steam produced.

8. Keep the work in the bath until it may be touched without burning the hand, or until the instant the "vibration" in the tongs is no longer felt, then remove it and *reheat until a drop of water will bubble on the surface*. This is called "taking the snap out." The work as it comes from the bath is under enormous hardening strains. Taking the snap out means reducing these strains to a considerable extent and has saved hundreds of pieces.

9. For the smaller cutting tools or work of a frail cross section or larger pieces that need not be especially hard, a bath of "quenching oil" is most satisfactory.

10. The hardness of a piece of steel may be tested with a file. Do not ruin a good file, use the corner of an old 8- or 10-in. pillar or a half-round file. A file will not "bite" into hardened steel until the temper has been drawn to a certain extent.

**Tempering Experiment—Temper Colors.** Take a piece of drill rod  $\frac{1}{4}$  in. or more in diameter and 5 or 6 in. long and harden it. Polish it bright and wipe it clean. Hold it in a pair of tongs and pass it lengthwise slowly back and forth over the fire allowing the heat to act most on the farther end and gradually less toward the end in the tongs. Examine it occasionally and observe that soon the silver brightness will disappear on the hottest end, giving way to a faint-yellow or light-straw color. As the rod is heated a little more, the light straw will creep up the rod and be followed successively on the end and along the rod by a dark straw—brown—brown with purple spots—purple—bright blue—dark blue.

Color	Degrees Fahrenheit
Pale yellow	430
Light straw	450
Dark straw	470
Brown	490
Brown with purple spots	510
Purple	530
Bright blue	560
Dark blue	600

These are called temper colors and are very useful many times to indicate the degree to which the steel has been reheated. This is called *drawing* the temper. With the corner of an old file test the hardness of various sections of the work. It will be noticed that the end which has been drawn to a blue files fairly easily, and that it is increasingly difficult to make the file bite as the portion of the rod showing light straw is approached.

The temperatures corresponding to the various colors are as shown in the table on page 618.

The colors themselves are merely different thicknesses of films of oxide which are caused by heating the steel to different degrees. The fact that a piece is temper-colored does not indicate that it has been hardened; a soft piece will color the same as a hard piece.

#### HINTS ON TEMPERING

1. Machine-shop tools of carbon steel will give good results if tempered about as follows:

Color	Tools
Pale yellow	Cutting tools for lathe, planer, shaper
Light straw	Milling cutters, drills, reamers
Dark straw	Taps and dies
Purple	Center punches, cold chisels
Purple verging into blue	Screw drivers

2. Common soft solder melts at approximately the heat required for tempering a milling cutter, reamer, or similar tool. Heat the piece carefully until it will melt the solder rubbed on it.

3. In tempering, the piece should be heated slowly, carefully, and thoroughly at some little distance from the fire; otherwise the thinner sections will be drawn lower than necessary before the heavier part is drawn enough.

4. The piece being tempered should be moved constantly, to bring each portion, when an even temper is desired, to the same degree of heat. Such a tool as a tap or a reamer or an end mill should be passed slowly back and forth over the flame and turned at the same time. The distance from the fire will depend on the intensity of the heat; do not attempt to draw the temper too quickly.



5. Small pieces may be tempered by being moved about on a heated plate until the temper is sufficiently drawn.

6. The most satisfactory method of tempering is by means of oil (tempering oil or cottonseed oil) heated to the desired temperature. The pieces are allowed to remain in the oil until they are thoroughly tempered. It does not injure them to remain longer than necessary in the oil, provided that the temperature does not rise.

7. When hardening and tempering cold chisels, screw drivers, or forged lathe, shaper, and planer tools, etc., it is customary to proceed as follows: Heat the piece somewhat farther back than is necessary, harden as much of it as desired, brighten the hardened part with a piece of emery cloth or a piece of a broken abrasive wheel, and then allow the heat in the unhardened portion to draw the temper. When the proper temper color is observed, dip the whole piece. One precaution should be emphasized: when hardening a piece as above, keep it moving up and down in the bath through a distance of half an inch or so, in order not to cause too sharp a line between the hardened and unhardened portions. If the piece is not moved it is liable to crack at the water line. It is also necessary to move the piece so that it is always in contact with cold water.

**High-speed Steel.** In the two experiments made it was demonstrated (1) that heating a piece of carbon steel above 1400° F. produced a coarse grain, and (2) that the range of temperature for tempers from glassy hard to practically soft was from about 400 to 600°. This is true for carbon steel but not true for high-speed steel.

Mushet, the famous English steel expert, discovered many years ago that a steel containing 1.5 per cent carbon, from 5 to 8 per cent tungsten, and about  $\frac{1}{2}$  per cent manganese would harden in an air blast, and would hold its temper until it was practically red hot. Mushet steel, or air-hardening steel as it was sometimes called, was therefore capable of taking a faster and heavier cut, since the friction did not burn out the temper and break down the cutting edge. But Mushet steel could not be readily machined and did not come into popular use.

It was not until the American investigators Messrs. Taylor and White discovered the special properties of steel with substantially 0.68 per cent carbon, 18 per cent tungsten, and 5 to 6 per cent

chromium, and developed a special process of heat-treatment of this steel, that the possibilities of high-speed steel were recognized. Since then (1898), dozens of different brands of high-speed steels have been manufactured.

There are two great advantages in the use of high-speed steel for cutting tools. (1) Greater leeway may be given in the heat-treating temperature—it is fairly difficult to spoil a piece of high-speed steel unless it is melted. (2) The temper is not ruined and the cutting edge does not break down even when the tool is red hot, consequently more than double the production can be obtained with a high-speed cutting tool than with a carbon-steel tool.

High-speed steel costs more than carbon steel. For milling cutters, lathe tools and much-used sizes of drills and machine reamers, it is worth much more than the extra cost.

The Taylor-White process is used for the treatment of tungsten-chromium steel.

### **TAYLOR-WHITE PROCESS**

#### *1. The high-heat treatment.*

- a. Heat slowly to 1500° F.
- b. Heat rapidly from 1500° F. to a white heat (2200° F.).
- c. Cool rapidly (kerosene bath) to below 1550° F.
- d. And cool either rapidly (kerosene) or slowly (air blast) to the temperature of the air.

#### *2. The low-heat treatment.*

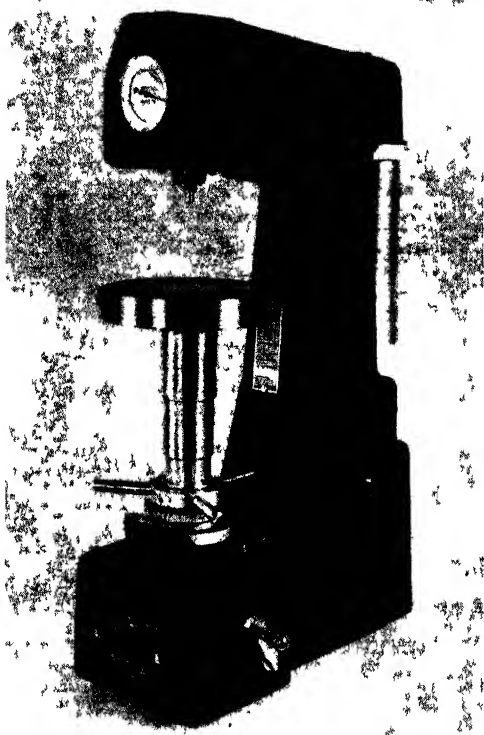
- e. Heat to a low red (1150° F.) for about 5 min.
- f. Cool either rapidly or slowly to the temperature of the air.

For molybdenum-chromium high-speed steel the treatment is substantially as above, except that in *b* it is unnecessary to heat the steel to a white heat; 1850° F is sufficient.

**Testing the Hardness of Steel.** Hardness is a property of metals whereby they resist being permanently deformed when a load is applied. The harder the substance, the greater is this resistance. Hardness can be measured in a few ways by hardness-testing machines.

The machines used ordinarily in measuring hardness are the

Brinell hardness tester, the Rockwell hardness tester, and the Shore scleroscope. Each machine has its own peculiar method and graduated scales for determining hardness in metals. For all purposes here, only one such machine will be described



**Fig. 19-3.** A Rockwell hardness tester (*Wilson Mechanical Instrument Company*)

*The Rockwell Hardness Tester.* The Rockwell hardness tester (Fig. 19-3) measures the resistance to penetration as does the Brinell machine, but the depth of impression is measured directly on the scale which is attached to the machine. This scale is, in fact, a depth gage graduated in very special units. In testing soft materials, a  $\frac{1}{16}$ -in.-diameter steel ball is used. With this steel ball, a load of 100

kilograms is used to provide the force for the penetration. The hardness of the soft material is read on the *B* scale.

For testing hard materials, a diamond cone is used, A 150-kilogram load is used with the diamond cone and the hardness is read directly on the *C* scale.

The advantages of the Rockwell tester are: (1) The test can be made very easily and quickly; (2) a small mark is left on the piece tested; and (3) very hard materials can be tested. Figure 19-4 shows a young lady using the Rockwell tester.



Fig. 19-4. The Rockwell in use. (*Wilson Mechanical Instrument Company*)

**Casehardening and Pack Hardening.** If low-carbon steel is heated sufficiently when in intimate contact with carbon or a carbonaceous material, it absorbs into its surface, or "case," in a certain length of time enough carbon to make high-carbon steel of this surface for a depth of several thousandths of an inch. Then if the steel is already red hot, or reheated until it is red hot, and quenched, the case is *hardened*, while the interior, being machine steel, remains unhardened and tough as ever.

Of the several casehardening compounds in the market, the best known is cyanide of potassium. The steel is heated in the cyanide or other casehardening compound in a special pot to a temperature of

about 1350° F. for a length of time— 15 min. or more—and then is quenched in water.

Be very careful in using cyanide of potassium. It is a *deadly poison*. Be careful, too, not to let any drop of water get into the cyanide, from wet tongs or otherwise; it will explode a mass of the cyanide.

*Pack hardening* serves the same purpose as cyaniding. The pieces are packed in iron boxes with carbon (usually charred bone), sealed with fire clay, and heated for several hours at approximately a hardening heat. This carbonizes the surface. The pieces are then allowed to cool in the furnace, to normalize them, and afterward are reheated to about 1350 °F. and quenched. Or possibly the smaller pieces being thus treated may be quenched directly from the hot packing box without normalizing. Special case-and pack-hardening processes give hardness to depths of over  $\frac{1}{16}$  in.

#### **DEFINITIONS: HEAT-TREATING OPERATIONS**

*Heat-treatment.* An operation, or combination of operations, involving the heating and cooling of a metal or an alloy in the solid state.

*NOTE:* This is for the purpose of obtaining certain desirable conditions or properties. Heating and cooling for the sole purpose of mechanical working are excluded from the meaning of this definition.

*Quenching.* Rapid cooling by immersion.

*NOTE:* Immersion may be in liquids, gases, or solids.

*Hardening.* Heating and quenching certain iron-base alloys from a temperature either within or above the critical temperature range.

*Annealing.* A heating and cooling operation of a material in the solid state.

*NOTE A:* Annealing usually implies a relatively slow cooling.

*NOTE B:* Annealing is a comprehensive term. The purpose of such a heat-treatment may be:

- a. To remove gases
- b. To remove stresses
- c. To induce softness
- d. To alter ductility; toughness; electrical, magnetic, or other physical properties
- e. To refine the crystalline structure

In annealing, the temperature of the operation and the rate of cooling depend upon the material being heat-treated and the *purpose* of the treatment.

Certain specific heat-treatments coming under the comprehensive term *annealing* are:

*Full Annealing.* Heating iron-base alloys above the critical temperature range, holding above the range for a proper time, followed by slow cooling through the range.

*NOTE:* The annealing temperature is generally about 100° F. above the upper limit of the critical temperature range, and the time of holding is usually not less than one hour for each inch of section of the heaviest objects being treated. The objects being treated are ordinarily allowed to cool slowly in the furnace. They may, however, be removed from the furnace, and cooled in some medium which will prolong the time of cooling as compared to unrestricted cooling in the air.

*Normalizing.* Heating iron-base alloys above the critical temperature range followed by cooling to below that range in still air at ordinary temperature.

*Tempering* (also termed *drawing*). Reheating, after hardening, to some temperature range followed by any desired rate of cooling.

*NOTE A:* Although the terms *tempering* and *drawing* are practically synonymous as used in commercial practice, the term *tempering* is preferred.

*NOTE B:* Tempering, meaning the operation of hardening followed by reheating, is a usage which is illogical and confusing in the present state of the art of heat-treating, and should be discouraged.

*Carburizing* (cementation). Adding carbon to iron-base alloys by heating the metal below its melting point in contact with carbonaceous material.

*NOTE:* The term *carbonizing* used in this sense is incorrect, so its use should be discouraged.

*Casehardening.* Carburizing and subsequent hardening by suitable heat-treatment, all or part of the surface portions of a piece of iron-base alloy.

*Case.* That portion of a carburized iron-base-alloy article in which the carbon content has been substantially increased.

*Core.* That portion of a carburized iron-base alloy article in which the carbon content has not been substantially increased.

*NOTE:* The terms *case* and *core* refer to both casehardening and carburizing.

*Cyaniding.* Surface hardening of an iron-base-alloy article or a portion of it by heating at a suitable temperature in contact with a cyanide salt, followed by quenching.

### QUESTIONS ON HARDENING AND TEMPERING STEEL

1. What element is always combined with iron in making steel?
2. What do you understand by the different structures that occur in steel as it cools from the recalescence point?
3. What is meant by martensitic structure or form?
4. Name two somewhat softer structures of heat-treated steel.
5. Explain the process of tempering tool steel.
6. With reference to the structure elements, explain the theory of tempering tool steel.
7. What is the difference between mild steel and carbon tool steel?
8. What is the difference between hardening and tempering?
9. What is the meaning of the term "point" in speaking of steel?
10. Explain how "Metcalf's experiment" is made.
11. Explain the value to the machinist of Metcalf's experiment.
12. In hardening steel why should it be heated thoroughly and evenly?
13. In tempering steel why should it be heated slowly and carefully?
14. What effect does overheating have in hardening?
15. What effect does overheating have in tempering?
16. What are temper colors? What do they indicate?
17. Does a cutter drawn in oil have temper colors? Explain.
18. What are some of the advantages of high-speed steel?
19. How is high-speed steel heat-treated?

# Cutting Fluids

---

## CHAPTER 20

---

### Cutting Fluids<sup>1</sup>

It is difficult to say just when and how the use of cutting fluids in metal-cutting operations began. Long before metal cutting, as we think of it now, had progressed to any great extent, water was used to cool tools sharpened on old-fashioned grindstones, and oil was applied to so-called *oilstones*, used for sharpening fine cutlery. So it seems reasonable to suppose that at least some experimental use of cutting fluids occurred not long after the development of the metal-cutting lathe. We know that the early users of air-hardening tool steels were warned *not* to use water on the tool during the cutting operation, which seems to indicate that such a practice might have been occasionally resorted to. We also know that in the work with tool steels by F. W. Taylor (prominent metallurgist in the 1890s), one of his discoveries, made about 1890, was that playing a stream of water just ahead of the nose of the cutting tool greatly increased the allowable cutting speed. In any event, since Taylor's time, cutting fluids have been recognized as playing an important part in the machining of metals. Many machining operations that are common today could not even be attempted without these fluids.

The development of cutting fluids has more or less paralleled the development of metal-cutting technique, machine design, and cutting-tool materials. As a result, progress has been most rapid in those periods when the demands of war and of new industrial developments have provided the greatest stimulus to new production processes. The demands of World War II and, particularly, the spectacular expansion of the aircraft industry have called for increased production with both existing and newly developed tools

<sup>1</sup> Courtesy of the Shell Oil Company, Inc., New York, N.Y.



and the machining of an ever-increasing number of new materials. In many instances the development of better cutting fluids has made possible what otherwise would have been impossible metal-cutting jobs.

As a consequence, ideas regarding the use of cutting fluids have undergone a rapid change in the past few years. Nevertheless, many excellent modern cutting oils contain some of the same ingredients, or at least modifications of them, that have been used in cutting fluids for many years. This should indicate that certain basic ingredients have the characteristics necessary to meet the demands imposed upon these fluids in actual practice.

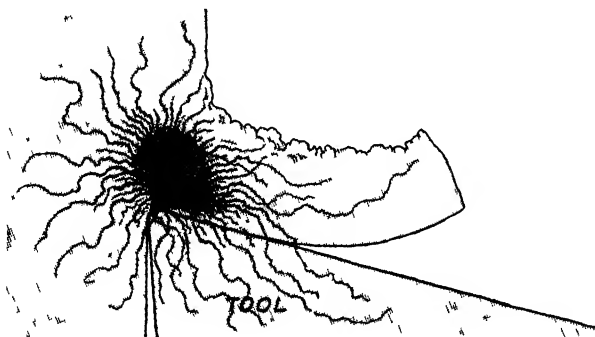
**Desired Characteristics in Cutting Fluids.** In order to determine what characteristics are needed in a cutting fluid, it is necessary to determine what it will have to do. First, a cutting fluid should fulfill a number of requirements, which may be summed up as representing "cutting quality." Cutting quality includes (1) a satisfactorily high cutting speed, (2) the production of a good surface finish, and (3) the attainment of economic tool life. In addition to these, the cutting fluid ought to prevent rust on the work and on the machine. It should cause no discoloration of the work; and finally, it must accomplish all these things without any objectionable features of service behavior. That is, it should not smoke or fog when in use, it should have no objectionable odor, it should not break down or separate in service, and it must not contain any substances harmful to the operator.

While the particular operating conditions will influence somewhat the importance of the functions just mentioned, it should be clear that cutting quality can be considered of most importance. In any case, to be satisfactory, a cutting fluid must make possible an efficient rate of metal removal, it must enable the operator to produce a smooth finish on the work, and it must contribute to longer tool life as measured between grindings, under a specific set of conditions. The ability of the cutting fluid to perform these duties depends to a considerable extent upon the nature of the cutting operation; the speed, feed, and depth of cut used; the type of tool being used; and the metallurgical characteristics of the metal being cut. Some of these factors have already been explained in other chapters of this text. A complete discussion of this subject would involve the funda-

mentals of the physics of the chip-forming process, including the influence of friction, pressure, temperature changes, heat flow, internal stresses, etc. However, the next section will help to clarify what might be considered the final result of these influencing factors, that is, the creation of heat.

**Sources of Heat Due to Metal Cutting.** The heat generated by a metal-cutting operation originates in three different sources: at the deformation of the metal, at chip distortion, and friction.

*Heat of Deformation* (Fig. 20-1). The pressure of the cutting tool on the workpiece is transmitted to the grains of metal adjacent to

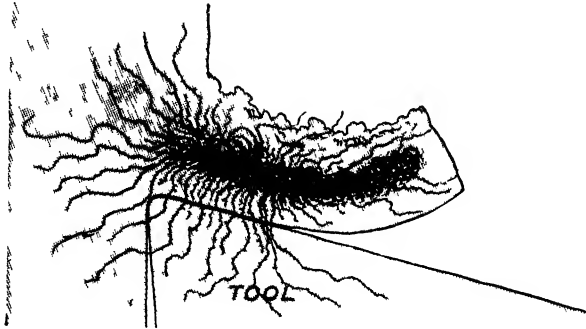


**Fig. 20-1.** Grains of metal adjacent to the face of the tool being deformed by heat. (*The Shell Oil Company*)

the face of the tool. This causes sections of these grains to slip along their lines or planes of weakness, deforming them all to some extent. The slipping of sections of grains over each other produces internal friction, which generates what we term the *heat of deformation*. Heavy feeds and deep cuts increase the heat of deformation by increasing the pressure and the number of grains involved. Tough metals, by being able to resist deformation to a large degree, also increase the heat thus generated.

*Heat of Chip Distortion* (Fig. 20-2). Since the chip separates from the workpiece along a line approximately perpendicular to the face of the tool, when it turns to pass off along the face of the tool, it must bend at virtually a right angle. As a result, the metal on the inside of the bend is compressed and wrinkled, while the metal on the outside of the bend is stretched and drawn out. This distortion

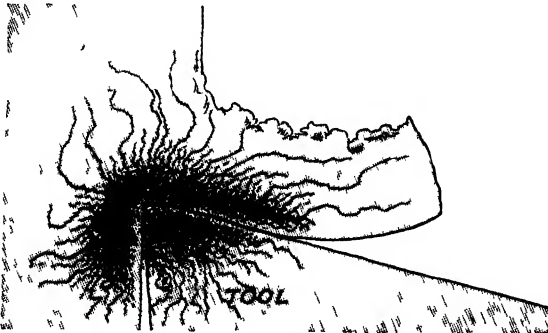
of the grains composing the chip results in internal friction, which generates what is called the *heat of chip distortion*. The greater the cross-sectional area of this chip, the greater the distortion and con-



**Fig 20-2.** Chip being distorted by the heat generated by the cutting action of the tool (*The Shell Oil Company*)

sequent heat when it is bent. Thus, heavy feeds and depths of cut increase the heat of chip distortion.

*Heat of Friction* (Fig 20-3) Heat of friction is generated during a cutting operation partly by the friction of the workpiece on the tool,



**Fig. 20-3.** Heat generated by the passing of the chip over the tool face (*The Shell Oil Company*)

but to a much greater extent by the friction of the chip as it passes over the tool face. Since the wedging action of the tool is largely concentrated on the chip at the point where it joins the workpiece, the pressure between the tool face and the chip is high. The rubbing

speed of the workpiece and the chip on the tool is approximately the same in feet per minute as the cutting speed of the particular operation. Thus, increased cutting speeds greatly increase the friction and, consequently, the heat of friction.

#### **Types of Cutting Fluids, Proper Selection, and Application.**

In order to become familiar with the modern types of cutting fluids and their proper selection and application, it is well to begin with some fundamental knowledge of the nature of the materials used in them and of the influence these materials have on the fluid's behavior. Perhaps as good a way as any to approach this subject is to review the history of their development.

Throughout this discussion, the term *cutting fluids* has been used. Although they are also commonly called *cutting oils*, we prefer to designate them by the former term because, while they are all fluids, they are not all—strictly speaking—oils. It will be remembered, for instance, that in Taylor's research into the effects of cutting fluids of metal cutting, he first used a stream of water. As a coolant, water was no doubt highly effective. However, from the foregoing discussion we know that, while cooling is important—and that is all Taylor gained by the use of water—there are other factors of equal or greater importance to be considered.

**Functions of Cutting Fluids.** To improve cutting efficiency, a cutting fluid must perform three separate, but related functions: *lubrication*, *cooling*, and *antiwelding* functions.

✓ *Lubricating Function.* The first and most obvious duty of the cutting fluid is to lubricate the tool, the workpiece, and the chip (Fig. 20-4). It is believed that as the chip separates from the workpiece, a partial vacuum is created in the "pocket" formed where tool, workpiece, and chip meet. This, combined with capillary action, tends to draw the cutting fluid to the point where the workpiece and the tool and the chip meet. Metal-to-metal contact, and consequently friction, is greatly reduced. Less power is required to turn the workpiece, less heat is generated, and tool wear is reduced.

*Cooling Function* (Fig. 20-5). Because heat always flows from a hotter substance to a cooler one, the heat generated by friction in the workpiece, tool, and chip tends to be absorbed and carried away by the cooler cutting fluid. The fluid itself is thus heated and would lose its cooling ability were it not constantly being displaced by cool

fluid. It is for this reason that cutting fluids should always flow steadily, in large quantities, over the tool and the workpiece. If sufficient fluid, flowing with sufficient velocity, is applied, heat can



Fig. 20-4. Cutting fluid acting as a lubricant for the work, tool, and chip (*The Shell Oil Company*)

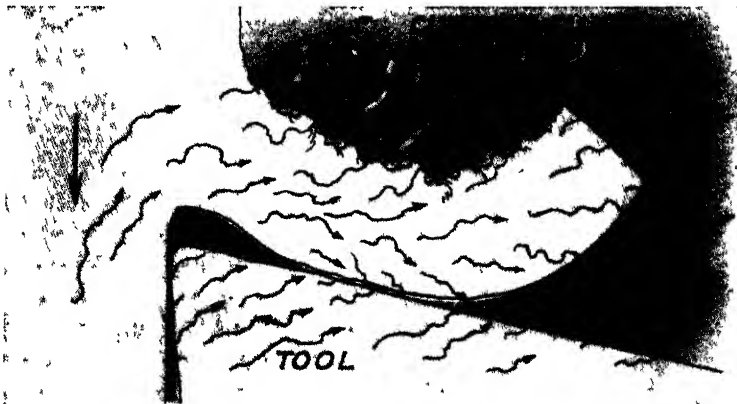


Fig. 20-5. Cutting fluid cooling the work and tool. (*The Shell Oil Company*)

be removed almost as fast as it is generated, and the temperatures of tool, workpiece, and chip can be controlled at safe working levels.

*Antiwelding Function* (Fig. 20-6). In spite of the lubricating and cooling action of the cutting fluid, some metal-to-metal contact always exists in limited areas on the workpiece, the tool, and the

chip, and the temperatures high enough to weld specks of metal to the workpiece and the tool are generated in limited areas. To prevent this, compounds of sulfur, chlorine, or other chemicals are added to cutting fluids. These coat the contact areas with a soapy, metallic film to which particles of metal will not weld readily. The film also provides what may be called *metallic lubrication* which helps reduce friction and tends to keep temperatures from rising above the welding point.

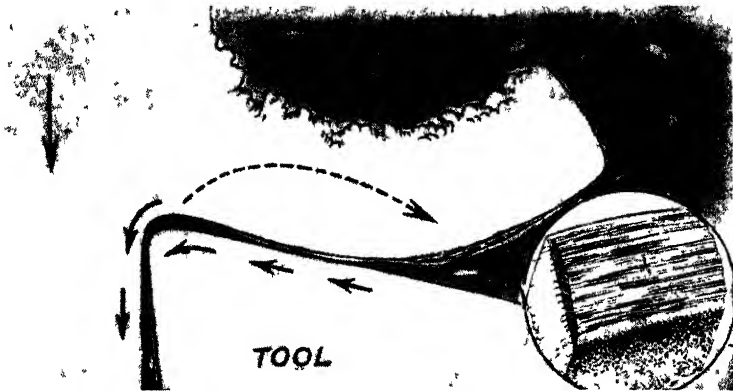


Fig. 20-6. Cutting fluid acting as a preventative against welding between the chip and tool (*The Shell Oil Company*)

Now let us get back to Taylor's experiment with water as a coolant. Water, far from acting as a rust preventive, actually causes the rusting of tools, machines, and ferrous work materials. This alone would have ruled out water as a cutting fluid. In addition, however, water offered little lubricating action, had very definite temperature limitations, and provided virtually no protection against galling.<sup>1</sup> Nevertheless, because of its exceptional cooling ability, efforts were made to combine water with other substances to make it a satisfactory cutting fluid. These met with little success until fairly recent times, when the modern soluble or emulsifiable oils were introduced.

Failing with water, investigators began to look to other fluids for

<sup>1</sup>*Galling.* A characteristic of metals which causes them to seize when brought into intimate contact with each other. A material that is subject to galling is one that will seize or "freeze" when brought into close contact with like material under pressure and no lubricant.

a possible solution. Inasmuch as oils possess the characteristics of rust prevention and lubrication, which water notably lacks, the natural thing to do was to try oils next. It was found that fatty oils, particularly lard oil, made a reasonably satisfactory cutting fluid. It did an excellent lubricating job, thus allowing increased cutting speeds and permitting smoother finish and longer tool life. That this was an important forward step is indicated by the fact that the majority of modern cutting fluids still contain some fatty oils.

Used alone, however, fatty oils offered several disadvantages. Important among these was their high cost. Equally important was the tendency of these oils to deteriorate, support bacterial growth, and become smelly in a short time if they were used under conditions generating high temperatures. About this time, mineral oils were becoming generally available and it was found that, by mixing fatty oils with mineral oils, the principal disadvantages of the former were overcome and most of their advantages were retained. As a result, cutting oils that were a blend of fatty oils and mineral oils came into wide use.

Neither the fatty oils nor the blend of fatty oils with mineral oils met the need for the prevention of galling or the transfer and welding of small particles of metal to the workpiece and the tool. Because it was known that sulfur had the ability to prevent the welding of two pieces of metal, various sulfur compounds were next added to blends of fatty and mineral oils, to provide these products with antiwelding properties.

At first, the sulfur was merely added to the oil in the form commonly known as *flowers of sulfur*. Later it was discovered that by bending at higher temperatures, more sulfur could be used effectively, as the result of the formation of weak, but nonetheless definite, chemical combinations with the oil. Subsequently, chlorine and phosphorus compounds, among others, were found to have similar merits as antiwelding agents. As a result of these discoveries and the development of improved blending techniques, present-day cutting fluids are often fairly complex materials, produced by carefully controlled scientific manufacturing methods.

One more substance should be mentioned, since it has been used with excellent results on certain types of metal-cutting operations. That is *air*. Applied under pressure from a nozzle located close to the

point of cutting, it is fairly effective as a coolant. But the practice of using air is quite dangerous unless proper precautions are taken. Chips will fly if they are small, and flying chips are always dangerous.

**Classification of Cutting Oils.** Though the kinds of cutting fluids may seem confusing at first, actually all that are commercially available can be classified in a way that is relatively simple. Modern cutting fluids fall into two major groups. The first is that of the *mineral cutting oils*, commonly known merely as *cutting oils*; the second is that of the *water-soluble*, or *emulsifiable*, oils, generally known simply as *soluble oils*.

Mineral oils are composed of one or more of the following ingredients in varying combinations: mineral oils, fatty oils or fatty acids, sulfur, chlorine or phosphorus, as well as other chemicals.

The water-soluble oils are composed of a mineral oil and an emulsifying base, the latter causing the formation of an oil-water emulsion when added to water.

The cooling function of modern cutting fluids is carried out by the mineral oil, which is their chief ingredient. Although the mineral oil functions as a lubricant, its principal value lies in its ability to transfer heat from the point of contact between the tool and the workpiece.

The reduction of friction is largely a function of the fatty oils or fatty acids commonly used in mineral cutting oils. These ingredients give the cutting oil extreme oiliness and the ability to spread over and cling to metal surfaces, which is known as its *metal-wetting* action. By reducing friction and frictional heat, these fatty oils and fatty acids also reduce tool wear and consumption and, at the same time, improve the surface finish.

The antiwelding action is provided by the sulfur or the chlorine and other less commonly used chemicals. Under the influence of heat generated by the cutting action, compounds of these chemicals coat the tool and the workpiece with a soaplike film, reducing the welding action.

In the case of the soluble oils, which are used in an oil-water emulsion, composed of one part oil and four to eighty parts of water, the cooling action is provided almost entirely by the water.

**Types of Mineral Oils.** The numerous mineral cutting oils generally available, however, are usually divided into two classes: (1) *active* and (2) *inactive* mineral cutting oils.



*Active* cutting oils include all those developed primarily for use under severe conditions, where good extreme-pressure properties are an essential requirement. They are most widely used in cutting ferrous metals.

*Inactive* cutting oils are those that contain no ingredients which have a discoloring effect on any metal that may be machined. If the machine is equipped with bearings of bronze or other alloys that might be ruined by the corrosive action of active cutting oils, the inactive oils are used.

**Choosing Correct Cutting Fluids.** As a result of the long-recognized necessity of developing some means whereby the experience gained in one shop could be made available to others, the Special Research Committee on Cutting of Metals of the American Society of Mechanical Engineers has worked for several years on the job of combining the results of extensive research and wide commercial experience in the form of a set of broad, general cutting-fluid recommendations.

These recommendations are based on the fact that the selection of a cutting fluid for a given operation must take into consideration two principal factors. The first factor is the cutting characteristic, or machinability, of the material being cut; the second is the nature of the operation itself, particularly its severity as represented by the friction, heat, tool wear, etc. Thus, as a starting point, the committee rated all commonly used metals on the basis of their machinability. Cold-rolled or cold-drawn steels were given an arbitrary rating of 100 per cent. Metals which were harder to cut than these steels were rated under 100 per cent. Those more easily machined were given ratings over 100 per cent. On the basis of these ratings, four class groups of ferrous metals and two of nonferrous metals were set up.

The committee then rated the most common types of machine operations according to their degree of severity. The most severe operation, internal broaching, was assigned a rating of 1, while the least severe, sawing, was rated 10.

To choose a proper cutting fluid, consult Table 16 in the Appendix. It should be remembered, in using this table, that the recommendations are necessarily general in nature and must be used with good judgment.

# Appendix

**Table 1. Mensuration**

AREA	
Parallelogram	= base $\times$ perpendicular height.
Trapezoid	= half the sum of the parallel sides $\times$ perpendicular height.
Triangle	= base $\times$ $\frac{1}{2}$ perpendicular height.
Circle	= diameter squared $\times$ 0.7854, or circumference squared $\times$ 0.07958.
Sector of a circle	= length of arc $\times$ half radius.
Segment of a circle	= $\left\{ \begin{array}{l} \text{area of sector of equal radius—triangle when seg-} \\ \text{ment is less, and + area of triangle when segment} \\ \text{is greater than the semicircle.} \end{array} \right.$
Side of square of equal area as circle	= diameter $\times$ 0.8862, or circumference $\times$ 0.2821.
Diameter of a circle of equal area as square	= side $\times$ 1.1284.
Parabola	= base $\times$ $\frac{2}{3}$ height.
Ellipse	= long diameter $\times$ short diameter $\times$ 0.7854.
Regular polygon	= sum of sides $\times$ half perpendicular distance from center to sides.
Cylinder	= circumference $\times$ height + area of both ends.
Sphere	= diameter squared $\times$ 3.1416, or diameter $\times$ circumference.
Segment of sphere	= height of segment $\times$ circumference of sphere of which it is a part + area of base.
Pyramid or cone	= circumference of base $\times$ $\frac{1}{2}$ slant height + area of base.
Frustrum of pyramid	= sum of circumference at both ends $\times$ $\frac{1}{2}$ slant height + area of both ends.

## LENGTH

Circumference of circle	= diameter $\times$ 3.1416.
Diameter of circle	= circumference $\times$ 0.3183.
Side of square of equal periphery as circle	= diameter $\times$ 0.7854.
Diameter of circle of equal periphery as square	= side $\times$ 1.2732.
Side of an inscribed square	= diameter of circle $\times$ 0.7071.
Length of arc	= number of degrees $\times$ diameter $\times$ 0.008727.
Circumference of circle whose diameter is 1	= 3.14159265.
English statute miles	= linear feet $\times$ 0.00019.
English statute miles	= linear yards $\times$ 0.000568.

## SOLID CONTENTS

Prism or cylinder	= area of end $\times$ length.
Sphere	= cube of diameter $\times$ 0.5236.
Segment of sphere	= (height squared + three times the square of radius of base) $\times$ (height $\times$ 0.5236).
Side of an equal cube	= diameter of sphere $\times$ 0.806.
Length of an equal cylinder	= diameter of sphere $\times$ 0.6667.
Pyramid or cone	= area of base $\times$ $\frac{1}{3}$ altitude.
Frustrum of cone	= $\left\{ \begin{array}{l} \text{add to the product of the two diameters the square of} \\ \text{the large diameter and the square of the small diam-} \\ \text{eter; multiply the sum by 0.7854 and the product} \\ \text{by } \frac{1}{3} \text{ the altitude.} \end{array} \right.$

Segment of sphere = (height squared + three times the square of radius of base)  $\times$  (height  $\times$  0.5236).

Side of an equal cube = diameter of sphere  $\times$  0.806.

Length of an equal cylinder = diameter of sphere  $\times$  0.6667.

Pyramid or cone = area of base  $\times$  1/3 altitude.

Frustum of cone =  $\left\{ \begin{array}{l} \text{add to the product of the two diameters the square of} \\ \text{the large diameter and the square of the small diam-} \\ \text{eter; multiply the sum by 0.7854 and the product by} \\ \frac{1}{3} \text{ the altitude.} \end{array} \right.$

**Table 2. Cutting Speeds: Lathe Work, Drills, Milling Cutters**

FORMULAS:  $CS = \frac{D \times r.p.m.}{4}$        $R.p.m. = \frac{4 CS}{D}$

		Cutting speeds in feet per minute																					
		20	30	40	50	60	70	80	90	100	110	120	130	140	150	160	170	180					
Dia., in.	Revolutions per minute																						
	3/4	3/8	1/2	5/8	3/4	7/8	1	1 1/8	1 1/4	1 3/8	1 1/2	1 5/8	1 3/4	1 7/8	2	2 1/8	2 1/4	2 3/8	2 1/2	2 5/8	2 3/4	3	
3/4	306	458	611	764	916	1070	1222	1376	1528	1681	1833	1986	2139	2292	2462	2615	2780						
3/8	204	306	407	509	612	712	814	916	1019	1120	1222	1324	1426	1528	1632	1735	1836						
1/2	153	229	306	382	458	534	612	688	764	840	917	993	1070	1146	1221	1298	1374						
5/8	122	183	244	306	366	428	488	550	611	672	733	794	856	917	976	1036	1098						
3/4	102	153	204	255	306	356	408	458	509	560	611	662	713	764	816	867	918						
7/8	87	131	175	218	262	306	350	392	437	480	524	568	611	655	699	742	786						
1	76	115	153	191	230	268	306	344	382	420	458	497	535	573	611	649	687						
1 1/8	68	102	136	170	204	238	272	306	340	373	407	441	475	509	542	576	610						
1 1/4	61	92	122	153	184	214	244	274	306	336	367	397	428	458	489	520	551						
1 3/8	56	83	111	139	167	194	222	250	278	306	333	361	389	417	444	472	500						
1 1/2	51	76	102	127	152	178	204	228	255	280	306	331	357	382	407	433	458						
1 5/8	47	71	94	118	141	165	188	212	235	259	282	306	329	353	377	400	423						
1 3/4	44	65	87	109	130	152	174	196	218	240	262	284	306	327	349	371	393						
1 7/8	41	61	82	102	122	143	163	183	204	224	244	265	285	306	326	346	366						
2	38	57	76	95	114	134	152	172	191	210	229	248	267	287	306	324	344						
2 1/8	36	54	72	90	108	126	144	162	180	198	216	234	252	270	288	306	323						
2 1/4	34	51	68	85	102	119	136	153	170	187	204	221	238	255	272	289	306						
2 3/8	32	48	64	80	97	112	129	145	161	177	193	210	225	241	257	273	290						
2 1/2	31	46	61	76	92	106	122	134	153	168	183	199	214	229	244	260	275						
2 5/8	29	44	58	73	88	102	117	130	146	160	175	189	204	218	233	248	262						
2 3/4	28	42	56	70	83	97	111	125	139	153	167	181	194	208	222	236	250						
2 7/8	27	40	53	67	80	93	106	119	133	146	159	173	186	199	213	226	239						
3	25	38	51	64	76	90	102	114	127	140	153	166	178	191	204	216	229						

**Table 3. Planer Cutting Speeds**

Actual number of feet of metal cut per minute with given forward speeds and various return speeds

Forward cutting speed in feet per minute	Return speed						
	2-1	3-1	4-1	5-1	6-1	7-1	8-1
20	13.3	15.00	16	16.66	17.14	17.50	17.76
25	16.6	18.75	20	20.83	21.42	21.87	22.16
30	20.0	22.50	24	25.00	25.71	26.25	26.56
35	23.3	26.25	28	29.16	30.00	30.62	31.04
40	26.6	30.00	32	33.33	34.28	35.00	35.52
45	30.0	33.75	36	37.50	38.56	39.37	40.00
50	33.3	37.50	40	41.66	42.84	43.75	44.48
55	36.6	41.25	44	45.83	47.12	48.12	48.95
60	40.0	45.00	48	50.00	51.42	52.50	53.43
65	43.3	48.75	52	54.16	55.70	56.87	57.91
70	46.6	52.50	56	58.33	60.00	61.25	62.30
75	50.0	56.25	60	62.50	64.28	66.62	66.71

The table shows clearly that a slight increase in cutting speed is better than high return speed. A 25-ft. forward speed at 4:1 return is much better than 8:1 return with 20-ft. forward speed. Economical planer speeds are given below (Cincinnati Planer Co.).

Cast-iron roughing, 40 to 50 ft., finishing, 20 to 25 ft.; steel-casting and wrought-iron roughing, 30 to 35 ft., finishing, 20 ft.; bronze and brass, 50 to 60 ft.; machinery steel, 30 to 35 ft.

Table 4. Diagonals of Hexagons and Squares (Inches)

Across flats	Across corners		Across flats	Across corners		Across flats	Across corners	
	Hexagon	Squares		Hexagon	Squares		Hexagon	Squares
$\frac{1}{16}$	0.072	0.088	$1\frac{3}{8}$	1.587	1.944	$21\frac{1}{16}$	3.103	3.800
$\frac{1}{8}$	0.144	0.177	$1\frac{7}{16}$	1.659	2.032	$2\frac{3}{4}$	3.175	3.889
$\frac{3}{16}$	0.216	0.265	$1\frac{1}{2}$	1.732	2.121	$2\frac{1}{2}$	3.247	3.979
$\frac{1}{4}$	0.288	0.353	$1\frac{9}{16}$	1.804	2.209	$2\frac{7}{8}$	3.319	4.065
$\frac{5}{16}$	0.360	0.441	$1\frac{5}{8}$	1.876	2.298	$2\frac{1}{2}$	3.391	4.154
$\frac{3}{8}$	0.432	0.530	$1\frac{1}{4}$	1.948	2.386	3	3.464	4.242
$\frac{7}{16}$	0.505	0.618	$1\frac{3}{4}$	2.020	2.470	$3\frac{1}{16}$	3.536	4.331
$\frac{1}{2}$	0.577	0.707	$1\frac{1}{2}$	2.092	2.563	$3\frac{1}{8}$	3.608	4.419
$\frac{9}{16}$	0.649	0.795	$1\frac{7}{8}$	2.165	2.651	$3\frac{1}{4}$	3.680	4.507
$\frac{5}{8}$	0.721	0.883	$1\frac{5}{4}$	2.237	2.740	$3\frac{1}{4}$	3.752	4.596
$1\frac{1}{16}$	0.793	0.972	2	2.309	2.828	$3\frac{1}{2}$	3.824	4.684
$\frac{3}{4}$	0.865	1.060	$2\frac{1}{16}$	2.381	2.916	$3\frac{3}{8}$	3.897	4.772
$1\frac{3}{16}$	0.938	1.149	$2\frac{1}{8}$	2.453	3.005	$3\frac{1}{2}$	4.041	4.949
$\frac{7}{8}$	1.010	1.237	$2\frac{3}{16}$	2.525	3.093	$3\frac{5}{8}$	4.185	5.126
$1\frac{5}{16}$	1.082	1.325	$2\frac{1}{4}$	2.598	3.182	$3\frac{3}{4}$	4.330	5.303
1	1.155	1.414	$2\frac{5}{16}$	2.670	3.270	$3\frac{7}{8}$	4.474	5.480
$1\frac{1}{8}$	1.226	1.502	$2\frac{3}{8}$	2.742	3.358	4	4.618	5.656
$1\frac{1}{8}$	1.299	1.591	$2\frac{7}{16}$	2.814	3.447	$4\frac{1}{8}$	4.763	5.833
$1\frac{3}{8}$	1.371	1.679	$2\frac{1}{2}$	2.886	3.535	$4\frac{1}{4}$	4.904	6.010
$1\frac{1}{4}$	1.443	1.767	$2\frac{9}{16}$	2.958	3.623	$4\frac{3}{8}$	5.051	6.187
$1\frac{5}{8}$	1.515	1.856	$2\frac{5}{8}$	3.031	3.712	$4\frac{1}{2}$	5.196	6.363

Diagonal of hexagon equals 1.155 times distance across flats.

Diagonal of square equals 1.414 times distance across flats.

Largest square that can be inscribed in circle equals 0.707 times the diameter.

Largest hexagon that can be inscribed in circle equals 0.866 times the diameter.

Largest square that can be cut on cylinder equals diameter times 0.707.

Largest hexagon that can be cut on cylinder equals diameter times 0.866.

Table 5. Weights of Steel and Wrought Iron

Diam- eter across flats	Steel				Iron	
	Weight per foot				Weight per foot	
	Round	Square	Hexagon	Octagon	Round	Square
$\frac{1}{16}$	0.010	0.013	0.012	0.011	0.010	0.013
$\frac{1}{8}$	0.042	0.053	0.046	0.044	0.041	0.052
$\frac{3}{16}$	0.094	0.119	0.103	0.099	0.092	0.117
$\frac{1}{4}$	0.167	0.212	0.185	0.177	0.164	0.208
$\frac{5}{16}$	0.261	0.333	0.288	0.277	0.256	0.326
$\frac{3}{8}$	0.375	0.478	0.414	0.398	0.368	0.469
$\frac{7}{16}$	0.511	0.651	0.564	0.542	0.501	0.638
$\frac{1}{2}$	0.667	0.850	0.737	0.708	0.654	0.833
$\frac{9}{16}$	0.845	1.076	0.932	0.896	0.828	1.055
$\frac{5}{8}$	1.043	1.328	1.151	1.107	1.023	1.302
$\frac{11}{16}$	1.262	1.608	1.393	1.331	1.237	1.576
$\frac{3}{4}$	1.502	1.913	1.658	1.584	1.473	1.875
$\frac{13}{16}$	1.763	2.245	1.944	1.860	1.728	2.201
$\frac{7}{8}$	2.044	2.603	2.256	2.156	2.004	2.552
$1\frac{1}{16}$	2.347	2.989	2.591	2.482	2.301	2.930
1	2.670	3.400	2.947	2.817	2.618	3.333
$1\frac{1}{8}$	3.014	3.838	3.327	3.182	2.955	3.763
$1\frac{1}{4}$	3.379	4.303	3.730	3.568	3.313	4.219
$1\frac{3}{16}$	3.766	4.795	4.156	3.977	3.692	4.701
$1\frac{1}{2}$	4.173	5.312	4.605	4.407	4.091	5.208
$1\frac{5}{16}$	4.600	5.857	5.077	4.858	4.510	5.742
$1\frac{3}{8}$	5.049	6.428	5.571	5.331	4.950	6.302
$1\frac{7}{16}$	5.518	7.026	6.091	5.827	5.410	6.888
$1\frac{1}{2}$	6.008	7.650	6.631	6.344	5.890	7.500
$1\frac{9}{16}$	6.520	8.301	7.195	6.905	6.392	8.138
$1\frac{5}{8}$	7.051	8.978	7.776	7.446	6.913	8.802
$1\frac{11}{16}$	7.604	9.682	8.392	8.027	7.455	9.492
$1\frac{3}{4}$	8.178	10.41	9.025	8.635	8.018	10.21
$1\frac{7}{8}$	8.773	11.17	9.682	9.264	8.601	10.95
$1\frac{9}{16}$	9.388	11.95	10.36	9.918	9.204	11.72
$1\frac{5}{8}$	10.02	12.76	11.06	10.58	9.828	12.51
2	10.68	13.60	11.79	11.28	10.47	13.33
$2\frac{1}{8}$	12.06	15.35	13.31	12.71	11.82	15.05
$2\frac{1}{4}$	13.52	17.22	14.92	14.24	13.25	16.88
$2\frac{3}{8}$	15.07	19.18	16.62	15.88	14.77	18.80
$2\frac{1}{2}$	16.69	21.25	18.42	17.65	16.36	20.83
$2\frac{5}{8}$	18.40	23.43	20.31	19.45	18.04	22.97
$2\frac{3}{4}$	20.20	25.71	22.29	21.28	19.80	25.21
$2\frac{7}{8}$	22.07	28.10	24.36	23.28	21.64	27.55
3	24.03	30.60	26.53	25.36	23.56	30.00
$3\frac{1}{8}$	26.08	33.20	28.78	27.50	25.57	32.55
$3\frac{1}{4}$	28.20	35.92	31.10	29.28	27.65	35.21
$3\frac{3}{8}$	30.42	38.78	33.57	32.10	29.82	37.97
$3\frac{1}{2}$	32.17	41.65	36.10	34.56	32.07	40.83
$3\frac{5}{8}$	35.09	44.68	38.73	37.05	34.40	43.80
$3\frac{3}{4}$	37.56	47.82	41.45	39.68	36.82	46.88
$3\frac{7}{8}$	40.10	51.05	44.26	42.35	39.31	50.05
4	42.73	54.40	47.16	45.12	41.89	53.33

## WIRE GAGES AND SHEET-METAL GAGES

Considerable confusion exists in regard to the gage numbers or the decimal equivalent of the gage numbers when ordering wires and sheets of the various metals, owing to the fact that there are so many gages listed in the tables given in handbooks, catalogues, textbooks, etc. Fortunately most of these older standards are obsolete or practically obsolete and only a few are now generally accepted and used in the trade. These are listed in Table 6.

*Steel Wire Gage*, formerly called the Washburn & Moen Gage, and also the American Steel & Wire Co. Steel Wire Gage, is the standard gage for steel and iron wire (excepting music wire [see "Music Wire Gage"]; for drill rods, see "Stubs' Steel Wire Gage"),

*The American Wire Gage*, also known as the *Brown & Sharpe* gage, is the generally accepted standard for copper wire (other than telephone and telegraph wire [see British Imperial Standard Wire Gage]), brass wire, german silver wire, and also for the thickness of *sheets* of these materials.

*The A. S. & W. Co. New Music Wire Gage* is regarded as standard in the United States, the older Washburn & Moen Music Wire Gage being obsolete. Foreign music wires are sized according to the respective makers' gages.

Music steel spring wire or "music wire" or "piano wire" is the best quality of steel wire and has, as noted, its own particular gage. Nos. 13 to 27 inclusive are used in pianos, some of the smaller sizes in other musical instruments. It is a tough wire of great tensile strength and resilience without extreme hardness. It is particularly useful for making springs since it does not have to be hardened and tempered. Do not confuse music wire with spring wire. *Spring Wire* is made to the Steel Wire Gage. It may be obtained with any desired carbon content for the purpose desired but is not as high grade as music steel spring wire.

*The Stubs' Steel Wire Gage* is commonly used in this country as well as in England for measuring drill rods. Do not get the Birmingham or Stubs' Iron Wire Gage confused with Stubs' Steel Wire Gage.

*The Birmingham or Stubs' Iron Wire Gage* (B. W. gage) was formerly used in the United States and in Great Britain to designate soft steel and iron wire. It is the gage used for iron telephone and telegraph wire, but for gaging other iron and steel wire, has been superseded to a great extent in Great Britain by the British Imperial Gage and in the United States by the Steel Wire Gage.

*British Imperial Standard Wire Gage* is now the standard gage of Great Britain. It is used by the American Telephone and Telegraph Co. as a gage for copper telephone and telegraph wire and is referred to as the New British Standard (N. B. Std.).

**RÉSUMÉ***Wires*

For steel wire, use Steel Wire Gage.

For copper telephone or telegraph wire, use British Imperial Standard Gage. For iron telephone or telegraph wire use Birmingham gage.

For copper, brass, and german silver wire, use American (Brown & Sharpe) gage.

For music wire use A. S. & W. *new* Music Wire Gage, and for imported music wire use gage of maker.

For drill rod use Stubs' Steel Wire gage.

*Sheets*

For iron and steel sheets and plates use United States Standard Gage.

For sheet copper, brass and german silver, use American (Brown & Sharpe) gage.

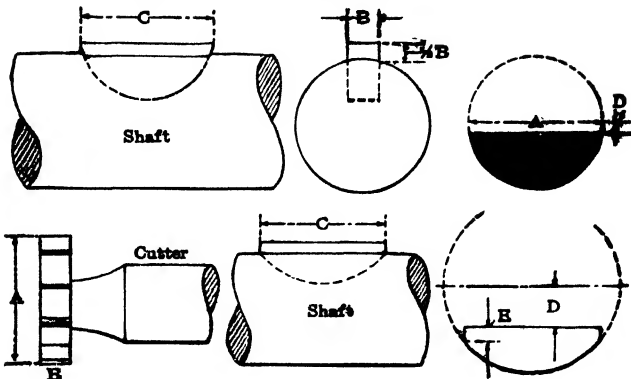
*Note.* When ordering, it is always well to give the decimal equivalent of the gage size and also the limits plus or minus, that will be acceptable.



**Table 6. Different Standards for Wire Gages and Sheet-metal Gages in Use in the United States**  
 Dimensions of sizes in decimal parts of an inch

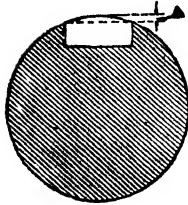
Gage numbers	Steel wire gage	American or Brown & Sharpe gage	American S. & W. Co. new music wire gage	Stubs' steel wire gage	Birmingham or Stubs' iron wire gage	British Imperial Standard wire gage	U.S. Standard gage for sheet and plate iron and steel	Gage numbers
6/0	.4615	.5800	.004	....		.464	.4687	6/0
5/0	.4305	.5165	.005	....	.500	.432	.4375	5/0
4/0	.3938	.4600	.006	....	.454	.400	.4062	4/0
3/0	.3625	.4096	.007	....	.425	.372	.375	3/0
2/0	.3310	.3648	.008	....	.380	.348	.3437	2/0
1/0	.3065	.3249	.009	....	.340	.324	.3125	1/0
1	.2830	.2893	.010	.227	.300	.300	.2812	1
2	.2625	.2576	.011	.219	.284	.276	.2656	2
3	.2437	.2294	.012	.212	.259	.252	.25	3
4	.2253	.2043	.013	.207	.238	.232	.2344	4
5	.2070	.1819	.014	.204	.220	.212	.2187	5
6	.1920	.1620	.016	.201	.203	.192	.2031	6
7	.1770	.1442	.018	.199	.180	.176	.1875	7
8	.1620	.1285	.020	.197	.165	.160	.1719	8
9	.1483	.1144	.022	.194	.148	.144	.1562	9
10	.1350	.1019	.024	.191	.134	.128	.1406	10
11	.1205	.0907	.026	.188	.120	.116	.125	11
12	.1055	.0808	.029	.185	.109	.104	.1094	12
13	.0915	.0720	.031	.182	.095	.092	.0937	13
14	.0800	.0641	.033	.180	.083	.080	.0781	14
15	.0720	.0571	.035	.178	.072	.072	.0703	15
16	.0625	.0508	.037	.175	.065	.064	.0625	16
17	.0540	.0452	.039	.172	.058	.056	.05625	17
18	.0475	.0403	.041	.168	.049	.048	.05	18
19	.0410	.0359	.043	.164	.042	.040	.04375	19
20	.0348	.032	.045	.161	.035	.036	.0375	20
21	.0317	.0285	.047	.157	.032	.032	.03437	21
22	.0286	.0253	.049	.155	.028	.028	.03125	22
23	.0258	.0226	.051	.153	.025	.024	.02812	23
24	.0230	.0201	.055	.151	.022	.022	.025	24
25	.0204	.0179	.059	.148	.020	.020	.02187	25
26	.0181	.0159	.063	.146	.018	.018	.01875	26
27	.0173	.0142	.067	.143	.016	.0164	.01718	27
28	.0162	.0126	.071	.139	.014	.0149	.01562	28
29	.0150	.0113	.075	.134	.013	.0136	.01406	29
30	.0140	.01	.080	.127	.012	.0124	.0125	30
31	.0132	.0089	.085	.120	.010	.0116	.01093	31
32	.0128	.00795	.090	.115	.009	.0108	.01015	32
33	.0118	.00708	.095	.112	.008	.0100	.00937	33
34	.0104	.0063	.100	.110	.007	.0092	.00859	34
35	.0095	.0056	.106	.108	.005	.0084	.00781	35
36	.0090	.005	.112	.106	.004	.0076	.00703	36
37	.0085	.00445	.118	.103	....	.0068	.00664	37
38	.0080	.00396	.124	.101	....	.0060	.00625	38
39	.0075	.00353	.130	.099	....	.0052	....	39
40	.0070	.00314	.138	.097	....	.0048	....	40
41	.0066	.00280	....	.095	....	.0044	....	41
42	.0062	.00249	....	.092	....	.0040	....	42
43	.0060	.00222	....	.088	....	.0036	....	43
44	.0058	.00198	....	.085	....	.0032	....	44
45	.0055	.00176	....	.081	....	.0028	....	45
46	.0052	.00157	....	.079	....	.0024	....	46
47	.0050	.00140	....	.077	....	.0020	....	47
48	.0048	.00124	....	.075	....	.0016	....	48
49	.0046	.000986	....	.072	....	.0012	....	49
50	.0044	.000878	....	.069	....	.001	....	50

Table 7. Woodruff Keys and Cutters



No. of key and cutter	Diameter of cutter	Thickness of key and cutter	Length of key	Key cut below center	No. of key and cutter	Diameter of cutter	Thickness of key and cutter	Length of key	Key cut below center	Flat at end of key
	A	B	C	D		A	B	C	D	E
1	1/2	1/16	1/2	3/64	D	1 1/4	5/16	1 1/4	5/64	
2	1/2	3/32	1/2	3/64	E	1 1/4	5/8	1 1/4	5/64	
3	1/2	1/8	1/2	3/64	22	1 3/8	1/4	1 3/8	3/32	
4	5/8	3/32	5/8	1/16	23	1 3/8	5/16	1 3/8	3/32	
5	5/8	1/8	5/8	1/16	F	1 3/8	3/8	1 3/8	3/32	
6	5/8	5/32	5/8	1/16	24	1 1/2	1/4	1 1/2	7/64	
7	3/4	1/8	3/4	1/16	25	1 1/2	5/16	1 1/2	7/64	
8	3/4	5/32	3/4	1/16	G	1 1/2	3/8	1 1/2	7/64	
9	3/4	3/16	3/4	1/16	26	2 1/8	3/16	2 3/8	17/32	3/32
10	7/8	5/32	7/8	1/16	27	2 1/8	1/4	2 3/8	17/32	3/32
11	7/8	3/16	7/8	1/16	28	2 1/8	5/16	2 3/8	17/32	3/32
12	7/8	7/32	7/8	1/16	29	2 1/8	3/8	2 3/8	17/32	3/32
A	7/8	1/4	7/8	1/16	R	2 3/4	1/4	2 7/8	5/8	1/8
13	1	3/16	1	1/16	S	2 3/4	5/16	2 7/8	5/8	1/8
14	1	7/32	1	1/16	T	2 3/4	3/8	2 7/8	5/8	1/8
15	1	1/4	1	1/16	U	2 3/4	7/16	2 7/8	5/8	1/8
B	1	5/16	1	1/16	V	2 3/4	1/2	2 7/8	5/8	1/8
16	1 1/8	3/16	1 1/8	5/64	30	3 1/2	3/8	2 7/8	13/16	3/16
17	1 1/8	7/32	1 1/8	5/64	31	3 1/2	7/16	2 7/8	13/16	3/16
18	1 1/8	1/4	1 1/8	5/64	32	3 1/2	1/2	2 7/8	13/16	3/16
C	1 1/8	5/16	1 1/8	5/64	33	3 1/2	9/16	2 7/8	13/16	3/16
19	1 1/4	3/16	1 1/4	5/64	34	3 1/2	5/8	2 7/8	13/16	3/16
20	1 1/4	7/32	1 1/4	5/64	35	3 1/2	11/16	2 7/8	13/16	3/16
21	1 1/4	1/4	1 1/4	5/64	36	3 1/2	3/4	2 7/8	13/16	3/16

Table 8. Finding Total Keyway Depth



In the column marked "Size of Shaft" find the number representing the size\*; then to the right find the column representing the keyway to be cut and the decimal there is the distance  $A$ , which added to the depth of the keyway will give the total depth from the point where the cutter first begins to cut.

Size of shaft, in.	Keyway, in.				
	$\frac{1}{4}$	$\frac{5}{16}$	$\frac{3}{8}$	$\frac{7}{16}$	$\frac{1}{2}$
$\frac{1}{2}$	0.0325				
$\frac{9}{16}$	0.0289				
$\frac{5}{8}$	0.0254	0.0413			
$1\frac{1}{16}$	0.0236	0.0379			
$\frac{3}{4}$	0.022	0.0346	0.0511		
$1\frac{3}{16}$	0.0198	0.0314	0.0465		
$\frac{7}{8}$	0.0177	0.0283	0.042	0.0583	
$1\frac{5}{16}$	0.0164	0.0264	0.0392	0.0544	
1	0.0152	0.0246	0.0365	0.0506	0.067
$1\frac{1}{16}$	0.0143	0.0228	0.0342	0.0476	0.0625
$1\frac{3}{8}$	0.0136	0.021	0.0319	0.0446	0.0581
$1\frac{3}{16}$	0.0131	0.0204	0.0304	0.0421	0.0551
$1\frac{1}{4}$	0.0127	0.0198	0.029	0.0397	0.0522
$1\frac{5}{16}$	0.0123	0.0191	0.0279	0.038	0.0449
$1\frac{3}{8}$	0.012	0.0185	0.0268	0.0364	0.0477
$1\frac{7}{16}$	0.0114	0.0174	0.0254	0.0346	0.0453
$1\frac{1}{2}$	0.011	0.0164	0.024	0.0328	0.0429
$1\frac{9}{16}$	0.0107	0.0158	0.0231	0.0309	0.0412
$1\frac{5}{8}$	0.0105	0.0153	0.0221	0.0291	0.0395
$1\frac{11}{16}$	0.0102	0.0147	0.0214	0.0282	0.0383
$1\frac{3}{4}$	0.0099	0.0142	0.0207	0.0274	0.0371
$1\frac{3}{16}$	0.0095	0.0136	0.0198	0.0265	0.0355
$1\frac{7}{8}$	0.0093	0.013	0.019	0.0257	0.0339
$1\frac{5}{16}$	0.009	0.0127	0.0184	0.025	0.0328
2	0.0088	0.0124	0.0179	0.0243	0.0317
$2\frac{1}{16}$	0.0083	0.0117	0.0173	0.0236	0.0308
$2\frac{1}{8}$	0.0078	0.0111	0.0168	0.0229	0.0299
$2\frac{3}{16}$	0.0073	0.0109	0.0163	0.0222	0.0291
$2\frac{1}{4}$	0.007	0.0107	0.0159	0.0216	0.0282

\* For larger sizes see F. H. Colvin and F. A. Stanley, *American Machinists' Handbook*, 8th ed., McGraw-Hill Book Company, Inc., 1945.

Table 9. Index Table for Fluting Reamers with Unequal Spacing

Number of flutes	Index circle	Regular indexing	1st index*	2d index	3d index	4th index	5th index	6th index	7th index	8th index
6	39	6 turns + 26 holes	Regular	Reg. + 15 holes	Reg. - 15 holes	See foot	note. †			
8	39	5 turns	Regular	Reg. + 15 holes	Reg. - 10 holes	Reg. - 5 holes				
10	39	4 turns	Regular	Reg. - 5 holes	Reg. + 10 holes	Reg. + 5 holes	Reg. - 10 holes			
12	39	3 turns + 13 holes	Regular	Reg. - 7 holes	Reg. + 2 holes	Reg. - 10 holes	Reg. + 6 holes	Reg. + 9 holes		
14	49	2 turns + 42 holes	Regular	Reg. - 7 holes	Reg. + 4 holes	Reg. - 9 holes	Reg. + 6 holes	Reg. + 10 holes	Reg. - 4 holes	
16	20	2 turns + 10 holes	Regular	Reg. - 4 holes	Reg. + 2 holes	Reg. - 3 holes	Reg. + 4 holes	Reg. + 2 holes	Reg. - 4 holes	Reg. + 3 holes

\* One groove to be cut before 1st indexing operation.

† Remaining half of number of grooves on all reamers will be cut like first half, beginning "1st index."  
*Courtesy Brown & Sharpe Manufacturing Co.*

Table 10. Tooth Parts of Gears

Diame- tral pitch	Circular pitch, in.	Thickness of tooth on pitch line, in.	Adden- dum, in.	Working depth of tooth, in.	Depth of space below pitch line, in.	Whole depth of tooth, in.
2	1.5708	0.7854	0.5000	1.0000	0.5785	1.0785
2 $\frac{1}{4}$	1.3963	0.6981	0.4444	0.8888	0.5143	0.9587
2 $\frac{1}{2}$	1.2566	0.6283	0.4000	0.8000	0.4628	0.8628
2 $\frac{3}{4}$	1.1424	0.5712	0.3636	0.7273	0.4208	0.7844
3	1.0472	0.5236	0.3333	0.6666	0.3857	0.7190
3 $\frac{1}{2}$	0.8976	0.4488	0.2857	0.5714	0.3306	0.6163
4	0.7854	0.3927	0.2500	0.5000	0.2893	0.5393
5	0.6283	0.3142	0.2000	0.4000	0.2314	0.4314
6	0.5236	0.2618	0.1666	0.3333	0.1928	0.3595
7	0.4488	0.2244	0.1429	0.2857	0.1653	0.3081
8	0.3927	0.1963	0.1250	0.2500	0.1446	0.2696
9	0.3491	0.1745	0.1111	0.2222	0.1286	0.2397
10	0.3142	0.1571	0.1000	0.2000	0.1157	0.2157
11	0.2856	0.1428	0.0909	0.1818	0.1052	0.1961
12	0.2618	0.1309	0.0833	0.1666	0.0964	0.1798
13	0.2417	0.1208	0.0769	0.1538	0.0890	0.1659
14	0.2244	0.1122	0.0714	0.1429	0.0826	0.1541
15	0.2094	0.1047	0.0666	0.1333	0.0771	0.1438
16	0.1963	0.0982	0.0625	0.1250	0.0723	0.1348
17	0.1848	0.0924	0.0588	0.1176	0.0681	0.1269
18	0.1745	0.0873	0.0555	0.1111	0.0643	0.1198
19	0.1653	0.0827	0.0526	0.1053	0.0609	0.1135
20	0.1571	0.0785	0.0500	0.1000	0.0579	0.1079
22	0.1428	0.0714	0.0455	0.0909	0.0526	0.0980
24	0.1309	0.0654	0.0417	0.0833	0.0482	0.0898
26	0.1208	0.0604	0.0385	0.0769	0.0445	0.0829
28	0.1122	0.0561	0.0357	0.0714	0.0413	0.0770
30	0.1047	0.0524	0.0333	0.0666	0.0386	0.0719

**Table 11. The Dimensions of Gears by Metric Pitch**

Module is the pitch diameter in millimeters divided by the number of teeth in the gear.

Pitch diameter in millimeters is the module multiplied by the number of teeth in the gear.

- $M$  = Module.
- $PD$  = The pitch diameter of gear.
- $OD$  = The outside diameter of gear.
- $N$  = The number of teeth in gear.
- $WD$  = The whole depth of teeth.
- $CTh$  = Thickness of teeth on pitch line.
- $C$  = Amount added to depth for clearance.

Then

$$A = M$$

$$M = \frac{PD}{N} \text{ or } \frac{OD}{N + 2}$$

$$PD = NM.$$

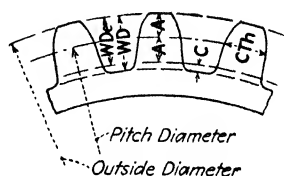
$$OD = (N + 2)M.$$

$$N = \frac{PD}{M} \text{ or } \frac{OD}{M} - 2.$$

$$WDe = 2M.$$

$$CTh = M \times 1.5708.$$

$$C = \frac{M \times 1.5708}{10} = 0.157M.$$



The module is equal to the part marked  $A$  in cut, measured in millimeters and parts of millimeter.

EXAMPLE: Module = 3.50 mm., 100 teeth.

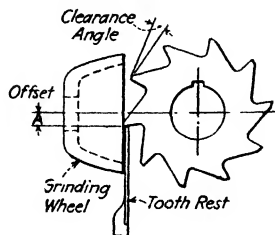
Pitch diameter =  $3.5 \times 100 = 350$  mm.

Outside diameter =  $(100 + 2) \times 3.5 = 357$  mm.

**PITCHES COMMONLY USED—MODULE IN MILLIMETERS**

Module, mm.	Corresponding English diametral pitch	Module, mm.	Corresponding English diametral pitch
$\frac{1}{2}$	50.800	4.5	5.644
$\frac{3}{4}$	33.867	5	5.080
1	25.400	5.5	4.618
1.25	20.320	6	4.233
1.5	16.933	7	3.628
1.75	14.514	8	3.175
2	12.700	9	2.822
2.25	11.288	10	2.540
2.5	10.160	11	2.309
2.75	9.236	12	2.117
3	8.466	14	1.814
3.5	7.257	16	1.587
4	6.350		

Table 12. Offsets for Obtaining Clearance on Milling Cutters



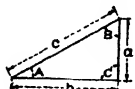
Have the tooth rest the distance  $A$  below the center line of the cutter according to the amount shown in the table for the diameter of the given cutter and the clearance angle desired.

EXAMPLE: For a cutter of 5-in. dia., 4-deg. clearance, offset  $A$  is 0.174 in

Dia. of cutter	Clearance angles and offsets					Dia. of cutter	Clearance angles and offsets			
	3°	4°	6°	8°	10°		3°	4°	6°	8°
$\frac{1}{8}$	0.003	0.004	0.006	0.009	0.111	$3\frac{3}{4}$	0.098	0.131	0.170	0.261
$\frac{1}{4}$	0.006	0.009	0.013	0.017	0.022	4	0.104	0.139	0.209	0.278
$\frac{3}{8}$	0.010	0.013	0.019	0.026	0.032	$4\frac{1}{2}$	0.118	0.157	0.235	0.313
$\frac{1}{2}$	0.013	0.017	0.026	0.035	0.043	5	0.131	0.174	0.261	0.348
$\frac{5}{8}$	0.016	0.022	0.033	0.043	0.054	$5\frac{1}{2}$	0.144	0.192	0.287	0.383
$\frac{3}{4}$	0.020	0.026	0.039	0.052	0.065	6	0.157	0.209	0.313	0.417
$\frac{7}{8}$	0.023	0.030	0.046	0.061	0.076	$6\frac{1}{2}$	0.170	0.227	0.340	0.452
1	0.026	0.035	0.052	0.069	0.087	7	0.183	0.244	0.366	0.487
$1\frac{1}{4}$	0.033	0.044	0.065	0.087		$7\frac{1}{2}$	0.196	0.262	0.392	0.522
$1\frac{1}{2}$	0.039	0.052	0.078	0.104		8	0.209	0.279	0.418	0.557
$1\frac{3}{4}$	0.046	0.061	0.091	0.122		$8\frac{1}{2}$	0.222	0.296	0.444	0.591
2	0.052	0.070	0.104	0.139		9	0.235	0.314	0.470	0.626
$2\frac{1}{4}$	0.059	0.078	0.117	0.156		$9\frac{1}{2}$	0.249	0.331	0.496	0.661
$2\frac{1}{2}$	0.065	0.087	0.131	0.174		10	0.262	0.349	0.523	0.696
$2\frac{3}{4}$	0.072	0.096	0.144	0.191		11	0.288	0.384	0.575	0.765
3	0.078	0.105	0.157	0.209		12	0.314	0.418	0.627	0.835
$3\frac{1}{4}$	0.085	0.113	0.170	0.226		13	0.340	0.453	0.679	0.905
$3\frac{1}{2}$	0.091	0.122	0.183	0.243		14	0.366	0.488	0.732	0.974

**Table 13. Trigonometrical Formulas, Etc.**

$$a = \sqrt{c^2 - b^2} \quad b = \sqrt{c^2 - a^2} \quad c = \sqrt{a^2 + b^2}$$



$$\sin A = \frac{a}{c} = \frac{\text{opposite side}}{\text{hypotenuse}}$$

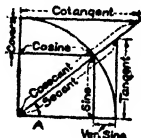
$$\tan A = \frac{a}{b} = \frac{\text{opposite side}}{\text{adjacent side}}$$

$$\sec A = \frac{c}{b} = \frac{\text{hypotenuse}}{\text{adjacent side}}$$

$$\cos A = \frac{b}{c} = \frac{\text{adjacent side}}{\text{hypotenuse}}$$

$$\cot A = \frac{b}{a} = \frac{\text{adjacent side}}{\text{opposite side}}$$

$$\operatorname{cosec} A = \frac{c}{a} = \frac{\text{hypotenuse}}{\text{opposite side}}$$



GENERAL EQUIVALENTS

The illustration shows the different trigonometrical expressions in terms of the angle  $A$ .

In the following formulas the radius = 1.

Complement of an angle = its difference from 90 deg.

Supplement of an angle = its difference from 180 deg.

$$\sin = \frac{1}{\operatorname{cosec}} = \frac{\cos}{\cot} = \sqrt{1 - \cos^2}$$

$$\cos = \sqrt{1 - \sin^2} = \frac{\sin}{\tan} = \sin \times \cot = \frac{1}{\sec}$$

$$\sec = \sqrt{\operatorname{rad}^2 + \tan^2} = \frac{1}{\cos} = \frac{\tan}{\sin}$$

$$\tan = \frac{\sin}{\cos} = \frac{1}{\cot}$$

$$\operatorname{cosec} = \frac{1}{\sin}$$

$$\cot = \frac{\cos}{\sin} = \frac{1}{\tan}$$

$$\operatorname{rad} = \tan \times \cot = \sqrt{\sin^2 + \cos^2}$$



Table 14. Trigonometric Functions

Angle	Sine	Cosine	Tan.	Cotan.	Secant	Cosec.	
0°00'	.00000	1.0000	.00000	Infinite	1.0000	Infinite	90°00'
5	.00145	1.0000	.00145	687.55	1.0000	687.55	55
10	.00291	.99999	.00291	343.77	1.0000	343.77	50
15	.00436	.99999	.00436	229.18	1.0000	229.18	45
20	.00582	.99998	.00582	171.88	1.0000	171.89	40
25	.00727	.99997	.00727	137.51	1.0000	137.51	35
30	.00873	.99996	.00873	114.59	1.0000	114.59	30
35	.01018	.99995	.01018	98.218	1.0000	98.223	25
40	.01163	.99993	.01164	85.940	1.0001	85.946	20
45	.01309	.99991	.01309	76.390	1.0001	76.396	15
50	.01454	.99989	.01454	68.750	1.0001	68.757	10
55	.01600	.99987	.01600	62.499	1.0001	62.507	5
1°00'	.01745	.99985	.01745	57.290	1.0001	57.299	89°00'
5	.01891	.99982	.01891	52.882	1.0002	52.891	55
10	.02036	.99979	.02036	49.104	1.0002	49.114	50
15	.02181	.99976	.02182	45.829	1.0002	45.840	45
20	.02326	.99973	.02327	42.964	1.0003	42.976	40
25	.02472	.99969	.02473	40.436	1.0003	40.448	35
30	.02618	.99966	.02618	38.188	1.0003	38.201	30
35	.02763	.99962	.02764	36.177	1.0004	36.191	25
40	.02908	.99958	.02910	34.368	1.0004	34.382	20
45	.03054	.99953	.03055	32.730	1.0005	32.745	15
50	.03199	.99949	.03201	31.241	1.0005	31.257	10
55	.03344	.99944	.03346	29.882	1.0005	29.899	5
2°00'	.03490	.99939	.03492	28.636	1.0006	28.654	88°00'
5	.03635	.99934	.03638	27.490	1.0007	27.508	55
10	.03781	.99928	.03783	26.432	1.0007	26.450	50
15	.03926	.99923	.03929	25.452	1.0008	25.471	45
20	.04071	.99917	.04075	24.542	1.0008	24.562	40
25	.04217	.99911	.04220	23.694	1.0009	23.716	35
30	.04362	.99905	.04366	22.904	1.0009	22.925	30
35	.04507	.99898	.04512	22.164	1.0010	22.186	25
40	.04652	.99892	.04657	21.470	1.0011	21.494	20
45	.04798	.99885	.04803	20.819	1.0011	20.843	15
50	.04943	.99878	.04949	20.205	1.0012	20.230	10
55	.05088	.99870	.05095	19.627	1.0013	19.653	5
	Cosine	Sine	Cotan.	Tan.	Cosec.	Secant	Angle

Table 14. Trigonometric Functions (Continued)

Angle	Sine	Cosine	Tan.	Cotan.	Secant	Cosec.	
3°00'	.05234	.99863	.05241	19.081	1.0014	19.107	87°00'
5	.05379	.99855	.05387	18.564	1.0014	18.591	55
10	.05524	.99847	.05532	18.075	1.0015	18.103	50
15	.05669	.99839	.05678	17.610	1.0016	17.639	45
20	.05814	.99831	.05824	17.169	1.0017	17.198	40
25	.05960	.99822	.05970	16.750	1.0018	16.779	35
30	.06105	.99813	.06116	16.350	1.0019	16.380	30
35	.06250	.99804	.06262	15.969	1.0019	16.000	25
40	.06395	.99795	.06408	15.605	1.0020	15.637	20
45	.06540	.99786	.06554	15.257	1.0021	15.290	15
50	.06685	.99776	.06700	14.924	1.0022	14.958	10
55	.06830	.99766	.06846	14.606	1.0023	14.640	5
4°00'	.06976	.99756	.06993	14.301	1.0024	14.335	86°00'
5	.07121	.99746	.07139	14.008	1.0025	14.043	55
10	.07266	.99736	.07285	13.727	1.0026	13.763	50
15	.07411	.99725	.07431	13.457	1.0027	13.494	45
20	.07556	.99714	.07577	13.197	1.0029	13.235	40
25	.07701	.99703	.07724	12.947	1.0030	12.985	35
30	.07846	.99692	.07870	12.706	1.0031	12.745	30
35	.07991	.99680	.08016	12.474	1.0032	12.514	25
40	.08136	.99668	.08163	12.250	1.0033	12.291	20
45	.08281	.99656	.08309	12.035	1.0034	12.076	15
50	.08426	.99644	.08456	11.826	1.0036	11.868	10
55	.08571	.99632	.08602	11.625	1.0037	11.668	5
5°00'	.08715	.99619	.08749	11.430	1.0038	11.474	85°00'
5	.08860	.99607	.08895	11.242	1.0039	11.286	55
10	.09005	.99594	.09042	11.059	1.0041	11.104	50
15	.09150	.99580	.09189	10.883	1.0042	10.929	45
20	.09295	.99567	.09335	10.712	1.0043	10.758	40
25	.09440	.99553	.09482	10.546	1.0045	10.593	35
30	.09584	.99540	.09629	10.385	1.0046	10.433	30
35	.09729	.99525	.09776	10.229	1.0048	10.278	25
40	.09874	.99511	.09922	10.078	1.0049	10.127	20
45	.10019	.99497	.11069	9.9310	1.0050	9.9812	15
50	.10163	.99482	.10216	9.7882	1.0052	9.8391	10
55	.10308	.99467	.10363	9.6493	1.0053	9.7010	5
	Cosine	Sine	Cotan.	Tan.	Cosec.	Secant	Angle

Table 14. Trigonometric Functions (Continued)

Angle	Sine	Cosine	Tan.	Cotan.	Secant	Cosec.	
6°00'	.10453	.99452	.10510	9.5144	1.0055	9.5668	84°00'
5	.10597	.99437	.10657	9.3831	1.0057	9.4362	55
10	.10742	.99421	.10805	9.2553	1.0058	9.3092	50
15	.10887	.99406	.10952	9.1309	1.0060	9.1855	45
20	.11031	.99390	.11099	9.0098	1.0061	9.0651	40
25	.11176	.99373	.11246	8.8918	1.0063	8.9479	35
30	.11320	.99357	.11393	8.7769	1.0065	8.8337	30
35	.11465	.99341	.11541	8.6648	1.0066	8.7223	25
40	.11609	.99324	.11688	8.5555	1.0068	8.6138	20
45	.11754	.99307	.11836	8.4489	1.0070	8.5079	15
50	.11898	.99290	.11983	8.3449	1.0071	8.4046	10
55	.12042	.99272	.12131	8.2434	1.0073	8.3039	5
7°00'	.12187	.99255	.12278	8.1443	1.0075	8.2055	83°00'
5	.12331	.99237	.12426	8.0476	1.0077	8.1094	55
10	.12476	.99219	.12574	7.9530	1.0079	8.0156	50
15	.12620	.99200	.12772	7.8606	1.0080	7.9240	45
20	.12764	.99182	.12869	7.7703	1.0082	7.8344	40
25	.12908	.99163	.13017	7.6821	1.0084	7.7469	35
30	.13053	.99144	.13165	7.5957	1.0086	7.6613	30
35	.13197	.99125	.13313	7.5113	1.0088	7.5776	25
40	.13341	.99106	.13461	7.4287	1.0090	7.4957	20
45	.13485	.99086	.13609	7.3479	1.0092	7.4156	15
50	.13629	.99067	.13757	7.2687	1.0094	7.3372	10
55	.13773	.99047	.13906	7.1912	1.0096	7.2604	5
8°00'	.13917	.99027	.14054	7.1154	1.0098	7.1853	82°00'
5	.14061	.99006	.14202	7.0410	1.0100	7.1117	55
10	.14205	.98986	.14351	6.9682	1.0102	7.0396	50
15	.14349	.98965	.14499	6.8969	1.0104	6.9690	45
20	.14493	.98944	.15648	6.8269	1.0107	6.8998	40
25	.14637	.98923	.14796	6.7584	1.0109	6.8320	35
30	.14781	.98901	.14945	6.6911	1.0111	6.7655	30
35	.14925	.98880	.15094	6.6252	1.0113	6.7003	25
40	.15068	.98858	.15243	6.5605	1.0115	6.6363	20
45	.15212	.98836	.15391	6.4971	1.0118	6.5736	15
50	.15356	.98814	.15540	6.4348	1.0120	6.5121	10
55	.15500	.98791	.15689	6.3737	1.0122	6.4517	5
	Cosine	Sine	Cotan.	Tan.	Cosec.	Secant	Angle

Table 14. Trigonometric Functions (Continued)

Angle	Sine	Cosine	Tan.	Cotan.	Secant	Cosec.	
9°00'	.15643	.98769	.15838	6.3137	1.0125	6.3924	81°00'
5	.15787	.98746	.15987	6.2548	1.0127	6.3343	55
10	.15931	.98723	.16137	6.1970	1.0129	6.2772	50
15	.16074	.98700	.16286	6.1402	1.0132	6.2211	45
20	.16218	.98676	.16435	6.0844	1.0134	6.1661	40
25	.16361	.98652	.16585	6.0296	1.0136	6.1120	35
30	.16505	.98628	.16734	5.9758	1.0139	6.0588	30
35	.16648	.98604	.16884	5.9228	1.0141	6.0066	25
40	.16791	.98580	.17033	5.8708	1.0144	5.9554	20
45	.16935	.98556	.17183	5.8196	1.0146	5.9049	15
50	.17078	.98531	.17333	5.7694	1.0149	5.8554	10
55	.17221	.98506	.17483	5.7199	1.0152	5.8067	5
10°00'	.17365	.98481	.17663	5.6713	1.0154	5.7588	80°00'
5	.17508	.98455	.17783	5.6234	1.0157	5.7117	55
10	.17651	.98430	.17933	5.5764	1.0159	5.6643	50
15	.17794	.98404	.18083	5.5301	1.0162	5.6197	45
20	.17937	.98378	.18233	5.4845	1.0165	5.5749	40
25	.18080	.98352	.18383	5.4396	1.0167	5.5308	35
30	.18223	.98325	.18534	5.3955	1.0170	5.4874	30
35	.18366	.98299	.18684	5.3521	1.0173	5.4447	25
40	.18509	.98272	.18835	5.3093	1.0176	5.4026	20
45	.18652	.98245	.18985	5.2671	1.0179	5.3612	15
50	.18795	.98218	.19136	5.2257	1.0181	5.3205	10
55	.18938	.98190	.19287	5.1848	1.0184	5.2803	5
11°00'	.19081	.98163	.19438	5.1445	1.0187	5.2408	79°00'
5	.19224	.98135	.19589	5.1049	1.0190	5.2019	55
10	.19366	.98107	.19740	5.0658	1.0193	5.1636	50
15	.19509	.98078	.19891	5.0273	1.0196	5.1258	45
20	.19652	.98050	.20042	4.9894	1.0199	5.0886	40
25	.19794	.98021	.20194	4.9520	1.0202	5.0520	35
30	.19937	.97992	.20345	4.9151	1.0205	5.0158	30
35	.20079	.97963	.20497	4.8788	1.0208	4.9802	25
40	.20222	.97934	.20648	4.8430	1.0211	4.9452	20
45	.20364	.97904	.20800	4.8077	1.0214	4.9106	15
50	.20506	.97875	.20952	4.7728	1.0217	4.8765	10
55	.20649	.97845	.21104	4.7385	1.0220	4.8429	5
	Cosine	Sine	Cotan.	Tan.	Cosec.	Secant	Angle

Table 14. Trigonometric Functions (Continued)

Angle	Sine	Cosine	Tan.	Cotan.	Secant	Cosec.	
12°00'	.20791	.97815	.21256	4.7046	1.0223	4.8097	78°00'
5	.20933	.97784	.21408	4.6712	1.0226	4.7770	55
10	.21076	.97754	.21560	4.6382	1.0230	4.7448	50
15	.21218	.97723	.21712	4.6057	1.0233	4.7130	45
20	.21360	.97692	.21864	4.5736	1.0236	4.6817	40
25	.21502	.97661	.22017	4.5420	1.0239	4.6507	35
30	.21644	.97630	.22169	4.5107	1.0243	4.6201	30
35	.21786	.97598	.22322	4.4799	1.0246	4.5901	25
40	.21928	.97566	.22475	4.4494	1.0249	4.5604	20
45	.22070	.97534	.22628	4.4194	1.0253	4.5311	15
50	.22211	.97502	.22781	4.3897	1.0256	4.5021	10
55	.22353	.97470	.22934	4.3604	1.0260	4.4736	5
13°00'	.22495	.97437	.23087	4.3315	1.0263	4.4454	77°00'
5	.22637	.97404	.23240	4.3029	1.0266	4.4176	55
10	.22778	.97371	.23393	4.2747	1.0270	4.3901	50
15	.22920	.97338	.23547	4.2468	1.0273	4.3630	45
20	.23061	.97304	.23700	4.2193	1.0277	4.3362	40
25	.23203	.97271	.23854	4.1921	1.0280	4.3098	35
30	.23344	.97237	.24008	4.1653	1.0284	4.2836	30
35	.23486	.97203	.24162	4.1388	1.0288	4.2579	25
40	.23627	.97169	.24316	4.1126	1.0291	4.2324	20
45	.23768	.97134	.24470	4.0867	1.0295	4.2072	15
50	.23910	.97099	.24624	4.0611	1.0299	4.1824	10
55	.24051	.97065	.24778	4.0358	1.0302	4.1578	5
14°00'	.24192	.97029	.24933	4.0108	1.0306	4.1336	76°00'
5	.24333	.96994	.25087	3.9861	1.0310	4.1096	55
10	.24474	.96959	.25242	3.9616	1.0314	4.0859	50
15	.24615	.96923	.25397	3.9375	1.0317	4.0625	45
20	.24756	.96887	.25552	3.9136	1.0321	4.0394	40
25	.24897	.96851	.25707	3.8900	1.0325	4.0165	35
30	.25038	.96815	.25862	3.8667	1.0329	3.9939	30
35	.25179	.96778	.26017	3.8436	1.0333	3.9716	25
40	.25319	.96741	.26172	3.8208	1.0337	3.9495	20
45	.25460	.96704	.26328	3.7983	1.0341	3.9277	15
50	.25601	.96667	.26483	3.7759	1.0345	3.9061	10
55	.25741	.96630	.26639	3.7539	1.0349	3.8848	5
	Cosine	Sine	Cotan.	Tan.	Cosec.	Secant	Angle

Table 14. Trigonometric Functions (Continued)

Angle	Sine	Cosine	Tan.	Cotan.	Secant	Cosec.	
15°00'	.25882	.96592	.26795	3.7320	1.0353	3.8637	76°00'
5	.26022	.96555	.26951	3.7104	1.0357	3.8428	55
10	.26163	.96517	.27107	3.6891	1.0361	3.8222	50
15	.26303	.96479	.27263	3.6679	1.0365	3.7018	45
20	.26443	.96440	.27419	3.6470	1.0369	3.7816	40
25	.26584	.96402	.27576	3.6263	1.0373	3.7617	35
30	.26724	.96363	.27732	3.6059	1.0377	3.7420	30
35	.26864	.96325	.27889	3.5856	1.0382	3.7224	25
40	.27004	.96285	.28046	3.5656	1.0386	3.7301	20
45	.27144	.96245	.28203	3.5457	1.0930	3.6840	15
50	.27284	.96206	.28360	3.5261	1.0394	3.6651	10
55	.27424	.96166	.28517	3.5066	1.0399	3.6464	5
16°00'	.27564	.96126	.28674	3.4874	1.0403	3.6279	74°00'
5	.27703	.96086	.28832	3.4684	1.0407	3.6096	55
10	.27843	.96045	.28990	3.4495	1.0412	3.5915	50
15	.27983	.96055	.29147	3.4308	1.0416	3.5736	45
20	.28122	.95964	.29305	3.4124	1.0420	3.5559	40
25	.28262	.95923	.29463	3.3941	1.0425	3.5383	35
30	.28401	.95882	.29621	3.3759	1.0429	3.5209	30
35	.28541	.95840	.29780	3.3580	1.0434	3.5037	25
40	.28680	.95799	.29938	3.3402	1.0438	3.4867	20
45	.28820	.95757	.30096	3.3226	1.0443	3.4698	15
50	.28959	.95715	.30255	3.3052	1.0448	3.4532	10
55	.29098	.95673	.30414	3.2879	1.0452	3.4366	5
17°00'	.29237	.95630	.30573	3.2708	1.0457	3.4203	73°00'
5	.29376	.95588	.30732	3.2539	1.0461	3.4041	55
10	.29515	.95545	.30891	3.2371	1.0466	3.3881	50
15	.29654	.95502	.31051	3.2205	1.0471	3.3722	45
20	.29793	.95459	.31210	3.2041	1.0476	3.3565	40
25	.29932	.95415	.31370	3.1877	1.0480	3.3409	35
30	.30070	.95372	.31530	3.1716	1.0485	3.3255	30
35	.30209	.95328	.31690	3.1556	1.0490	3.3102	25
40	.30348	.95284	.31850	3.1397	1.0495	3.2951	20
45	.30486	.95239	.32010	3.1240	1.0500	3.2801	15
50	.30625	.95195	.32171	3.1084	1.0505	3.2653	10
55	.30763	.95150	.32331	3.0930	1.0510	3.2506	5
	Cosine	Sine	Cotan.	Tan.	Cosec.	Secant	Angle

Table 14. Trigonometric Functions (Continued)

Angle	Sine	Cosine	Tan.	Cotan.	Secant	Cosec.	
18°00'	.30902	.95106	.32492	3.0777	1.0515	3.2361	72°00'
5	.31040	.95061	.32653	3.0625	1.0520	3.2216	55
10	.31178	.95015	.32814	3.0475	1.0525	3.2074	50
15	.31316	.94970	.32975	3.0326	1.0530	3.1932	45
20	.31454	.94924	.33136	3.0178	1.0535	3.1792	40
25	.31592	.94878	.33298	3.0032	1.0540	3.1653	35
30	.31730	.94832	.33459	2.9887	1.0545	3.1515	30
35	.31868	.94786	.33621	2.9743	1.0550	3.1379	25
40	.32006	.94740	.33783	2.9600	1.0555	3.1244	20
45	.32144	.94693	.33945	2.9459	1.0560	3.1110	15
50	.32282	.94646	.34108	2.9319	1.0566	3.0977	10
55	.32419	.94599	.34270	2.9180	1.0571	3.0845	5
19°00'	.32557	.94552	.34433	2.9042	1.0576	3.0715	71°00'
5	.32694	.94504	.34595	2.8905	1.0581	3.0586	55
10	.32832	.94457	.34758	2.8770	1.0587	3.0458	50
15	.32969	.94409	.34921	2.8636	1.0592	3.0331	45
20	.33106	.94361	.35085	2.8502	1.0598	3.0206	40
25	.33243	.94313	.35248	2.8370	1.0603	3.0081	35
30	.33381	.94264	.35412	2.8239	1.0608	2.9957	30
35	.33518	.94215	.35576	2.8109	1.0614	2.9835	25
40	.33655	.94167	.35739	2.7980	1.0619	2.9713	20
45	.33792	.94118	.35904	2.7852	1.0625	2.9593	15
50	.33928	.94068	.36068	2.7725	1.0630	2.9474	10
55	.34065	.94019	.36232	2.7600	1.0636	2.9355	5
20°00'	.34202	.93969	.36397	2.7475	1.0642	2.9238	70°00'
5	.34339	.93919	.36562	2.7351	1.0647	2.9122	55
10	.34475	.93869	.36727	2.7228	1.0653	2.9006	50
15	.34612	.93819	.36892	2.7106	1.0659	2.8892	45
20	.34748	.93769	.37057	2.6985	1.0664	2.8788	40
25	.34884	.93718	.37223	2.6865	1.0670	2.8686	35
30	.35021	.93667	.37388	2.6746	1.0676	2.8584	30
35	.35157	.93616	.37554	2.6628	1.0682	2.8484	25
40	.35293	.93565	.37720	2.6511	1.0688	2.8384	20
45	.35429	.93513	.37887	2.6394	1.0694	2.8285	15
50	.35565	.93462	.38053	2.6279	1.0699	2.8177	10
55	.35701	.93410	.38220	2.6164	1.0705	2.8070	5
	Cosine	Sine	Cotan.	Tan.	Cosec.	Secant	Angle

Table 14. Trigonometric Functions (Continued)

Angle	Sine	Cosine	Tan.	Cotan.	Secant	Cosec.	
21°00'	.35837	.93358	.38386	2.6051	1.0711	2.7904	69°00'
5	.35972	.93306	.38553	2.5938	1.0717	2.7799	55
10	.36108	.93253	.38720	2.5826	1.0723	2.7694	50
15	.36244	.93201	.38888	2.5715	1.0729	2.7591	45
20	.36379	.93148	.39055	2.5605	1.0736	2.7488	40
25	.36515	.93095	.39223	2.5495	1.0742	2.7386	35
30	.36650	.93042	.39391	2.5386	1.0748	2.7285	30
35	.36785	.92988	.39559	2.5278	1.0754	2.7184	25
40	.36921	.92935	.39727	2.5171	1.0760	2.7085	20
45	.37056	.92881	.39896	2.5065	1.0766	2.6986	15
50	.37191	.92827	.40065	2.4960	1.0773	2.6888	10
55	.37326	.92773	.40233	2.4855	1.0779	2.6791	5
22°00'	.37461	.92718	.40403	2.4751	1.0785	2.6695	68°00'
5	.37595	.92664	.40752	2.4647	1.0792	2.6599	55
10	.37730	.92609	.40741	2.4545	1.0798	2.6504	50
15	.37865	.92554	40911	2.4443	1.0804	2.6410	45
20	.37999	.92499	.41081	2.4342	1.0811	2.6316	40
25	.38134	.92443	.41251	2.4242	1.0817	2.6223	35
30	.38268	.92388	.41421	2.4142	1.0824	2.6131	30
35	.38403	.92332	.41592	2.4043	1.0830	2.6040	25
40	.38537	.92276	.41762	2.3945	1.0837	2.5949	20
45	.38671	.92220	.41933	2.3847	1.0844	2.5859	15
50	.38805	.92164	.42105	2.3750	1.0850	2.5770	10
55	.38939	.92107	.42276	2.3654	1.0857	2.5681	5
23°00'	.39073	.92050	.42447	2.3558	1.0864	2.5593	67°00'
5	.39207	.91993	.42619	2.3463	1.0870	2.5506	55
10	.39341	.91936	.42791	2.3369	1.0877	2.5419	50
15	.39474	.91879	.42963	2.3276	1.0884	2.5333	45
20	.39608	.91822	.43136	2.3183	1.0891	2.5247	40
25	.39741	.91764	.43308	2.3090	1.0897	2.5163	35
30	.39875	.91706	.43481	2.2998	1.0904	2.5078	30
35	.40008	.91648	.43654	2.2907	1.0911	2.4995	25
40	.40141	.91590	.43827	2.2817	1.0918	2.4912	20
45	.40275	.91531	.44001	2.2727	1.0925	2.4849	15
50	.40408	.91472	.44175	2.2637	1.0932	2.4748	10
55	.40541	.91414	.44349	2.2548	1.0939	2.4666	5
	Cosine	Sine	Cotan.	Tan.	Cosec.	Secant	Angle



Table 14. Trigonometric Functions (Continued)

Angle	Sine	Cosine	Tan.	Cotan.	Secant	Cosec.	
24°00'	.40674	.91354	.44523	2.2460	1.0946	2.4586	66°00'
5	.40806	.91295	.44697	2.2373	1.0953	2.4506	55
10	.40939	.91236	.44872	2.2286	1.0961	2.4426	50
15	.41072	.91176	.45047	2.2199	1.0968	2.4347	45
20	.41204	.91116	.45222	2.2113	1.0975	2.4269	40
25	.41337	.91056	.45397	2.2028	1.0982	2.4191	35
30	.41469	.90996	.45573	2.1943	1.0989	2.4114	30
35	.41602	.90936	.45748	2.1859	1.0997	2.4037	25
40	.41734	.90875	.45924	2.1775	1.1004	2.3961	20
45	.41866	.90814	.46101	2.1692	1.1011	2.3886	15
50	.41998	.90753	.46277	2.1609	1.1019	2.3811	10
55	.42130	.90692	.46454	2.1527	1.1026	2.3735	5
25°00'	.42262	.90631	.46631	2.1445	1.1034	2.3662	65°00'
5	.42394	.90569	.46808	2.1364	1.1041	2.3588	55
10	.42525	.90507	.46985	2.1283	1.1049	2.3515	50
15	.42657	.90445	.47163	2.1203	1.1056	2.3443	45
20	.42788	.90383	.47341	2.1123	1.1064	2.3371	40
25	.42920	.90321	.47519	2.1044	1.1072	2.3299	35
30	.43051	.90258	.47697	2.0965	1.1079	2.3228	30
35	.43182	.90196	.47876	2.0887	1.1087	2.3158	25
40	.43313	.90133	.48055	2.0809	1.1095	2.3087	20
45	.43444	.90070	.48234	2.0732	1.1102	2.3018	15
50	.43575	.90006	.48414	2.0655	1.1100	2.2949	10
55	.43706	.89943	.48593	2.0579	1.1118	2.2880	5
26°00'	.43837	.89879	.48773	2.0503	1.1126	2.2812	64°00'
5	.43968	.89815	.48953	2.0427	1.1134	2.2744	55
10	.44098	.89751	.49134	2.0352	1.1142	2.2676	50
15	.44229	.89687	.49314	2.0278	1.1150	2.2610	45
20	.44349	.89623	.49495	2.0204	1.1158	2.2543	40
25	.44489	.89558	.49677	2.0130	1.1166	2.2477	35
30	.44620	.89493	.49858	2.0057	1.1174	2.2411	30
35	.44750	.89428	.50040	1.9984	1.1182	2.2348	25
40	.44880	.89363	.50222	1.9912	1.1190	2.2282	20
45	.45010	.89298	.50404	1.9840	1.1198	2.2217	15
50	.45140	.89232	.50587	1.9768	1.1207	2.2153	10
55	.45269	.89166	.50769	1.9697	1.1215	2.2090	5
	Cosine	Sine	Cotan.	Tan.	Cosec.	Secant	Angle

Table 14. Trigonometric Functions (Continued)

Angle	Sine	Cosine	Tan.	Cotan.	Secant	Cosec.	
27°00'	.45399	.89101	.50952	1.9626	1.1223	2.2027	36°00'
5	.45528	.89034	.51136	1.9556	1.1231	2.1964	55
10	.45658	.88968	.51319	1.9486	1.1240	2.1902	50
15	.45787	.88902	.51503	1.9416	1.1248	2.1840	45
20	.45917	.88835	.51687	1.9347	1.1257	2.1178	40
25	.46046	.88768	.51872	1.9278	1.1265	2.1717	35
30	.46175	.88701	.52057	1.9210	1.1274	2.1657	30
35	.46304	.88634	.52242	1.9142	1.1282	2.1596	25
40	.46433	.88566	.52427	1.9074	1.1291	2.1536	20
45	.45561	.88499	.52612	1.9007	1.1299	2.1477	25
50	.46690	.88431	.52798	1.8940	1.1308	2.1418	10
55	.46819	.88363	.52984	1.8873	1.1317	2.1359	5
28°00'	.46947	.88295	.53171	1.8807	1.1326	2.1300	62°00'
5	.47075	.88226	.53358	1.8741	1.1334	2.1242	55
10	.47204	.88158	.53545	1.8676	1.1343	1.1185	50
15	.47332	.88089	.53732	1.8611	1.1352	2.1127	45
20	.47460	.88020	.53919	1.8546	1.1361	2.1070	40
25	.47588	.87951	.54107	1.8482	1.1370	2.1014	35
30	.47716	.87882	.54295	1.8418	1.1379	2.0957	30
35	.47844	.87812	.54484	1.8354	1.1388	2.0901	25
40	.47971	.87742	.54673	1.8291	1.1397	2.0846	20
45	.48099	.87673	.54862	1.8227	1.1406	2.0790	15
50	.48226	.87603	.55051	1.8165	1.1415	2.0735	10
55	.48354	.87532	.55241	1.8102	1.1424	2.0681	5
29°00'	.48481	.87462	.55431	1.8040	1.1433	2.0627	61°00'
5	.48608	.87391	.55621	1.7979	1.1443	2.0573	55
10	.48735	.87320	.55812	1.7917	1.1452	2.0519	50
15	.48862	.87250	.56003	1.7856	1.1461	2.0466	45
20	.48989	.87178	.56194	1.7795	1.1471	2.0413	40
25	.49116	.87107	.56385	1.7735	1.1480	2.0360	35
30	.49242	.87035	.56577	1.7675	1.1489	2.0308	30
35	.49369	.86964	.46769	1.7615	1.1499	2.0256	25
40	.49495	.86892	.56962	1.7555	1.1508	2.0204	20
45	.49622	.86820	.57155	1.7496	1.1518	2.0152	15
50	.49748	.86748	.57348	1.7437	1.1528	2.0101	10
55	.49874	.86675	.57541	1.7379	1.1537	2.0050	5
	Cosine	Sine	Cotan.	Tan.	Cosec.	Secant	Angle

Table 14. Trigonometric Functions (Continued)

Angle	Sine	Cosine	Tan.	Cotan.	Secant	Cosec.	
30°00'	.50000	.86603	.57735	1.7320	1.1547	2.0000	60°00'
5	.50126	.86530	.57929	1.7262	1.1557	1.9950	55
10	.50252	.86457	.58123	1.7205	1.1566	1.9900	50
15	.50377	.86383	.58318	1.7147	1.1576	1.9850	45
20	.50503	.86310	.58513	1.7090	1.1586	1.9801	40
25	.50628	.86237	.58709	1.7033	1.1596	1.9752	35
30	.50754	.86163	.58904	1.6977	1.1606	1.9703	30
35	.50879	.86089	.59100	1.6920	1.1616	1.9654	25
40	.51004	.86015	.59297	1.6864	1.1626	1.9606	20
45	.51129	.85941	.59494	1.6808	1.1636	1.9558	15
50	.51254	.85866	.59691	1.6753	1.1646	1.9510	10
55	.51379	.85791	.59888	1.6698	1.1656	1.9463	5
31°00'	.51504	.85717	.60086	1.6643	1.1666	1.9416	59°00'
5	.51628	.85642	.60284	1.6588	1.1676	1.9369	55
10	.51753	.85566	.60483	1.6534	1.1687	1.9322	50
15	.51877	.85491	.60681	1.6479	1.1697	1.9276	45
20	.52002	.85416	.60881	1.6425	1.1707	1.9230	40
25	.52126	.85340	.61080	1.6372	1.1718	1.9184	35
30	.52250	.85264	.61280	1.6318	1.1728	1.9139	30
35	.52374	.85188	.61480	1.6265	1.1739	1.9093	25
40	.52498	.85112	.61681	1.6212	1.1749	1.9048	20
45	.52621	.85035	.61882	1.6160	1.1760	1.9004	15
50	.52745	.84959	.62083	1.6107	1.1770	1.8959	10
55	.52868	.84882	.62285	1.6055	1.1781	1.8915	5
32°00'	.52992	.84805	.62487	1.6003	1.1792	1.8871	58°00'
5	.53115	.84728	.62689	1.5952	1.1802	1.8827	55
10	.53238	.84650	.62892	1.5900	1.1813	1.8783	50
15	.53361	.84573	.63095	1.5849	1.1824	1.8740	45
20	.53484	.84495	.63299	1.5798	1.1835	1.8697	40
25	.53607	.84417	.63503	1.5747	1.1846	1.8654	35
30	.53730	.84339	.63707	1.5697	1.1857	1.8611	30
35	.53852	.84261	.63912	1.5646	1.1868	1.8569	25
40	.53975	.84182	.64117	1.5596	1.1879	1.8527	20
45	.54097	.84104	.64322	1.5547	1.1890	1.8485	15
50	.54220	.84025	.64528	1.5497	1.1901	1.8443	10
55	.54342	.83946	.64734	1.5448	1.1912	1.8402	5
	Cosine	Sine	Cotan.	Tan.	Cosec.	Secant	Angle

Table 14. Trigonometric Functions (Continued)

Angle	Sine	Cosine	Tan.	Cotan.	Secant	Cosec.	
33°00'	.54464	.83867	.64941	1.5399	1.1924	1.8361	57°00'
5	.54586	.83788	.65148	1.5350	1.1935	1.8320	55
10	.54708	.83708	.65355	1.5301	1.1946	1.8279	50
15	.54829	.83629	.65563	1.5252	1.1958	1.8238	45
20	.54951	.83549	.65771	1.5204	1.1969	1.8198	40
25	.55072	.83469	.65980	1.5156	1.1980	1.8158	35
30	.55193	.83388	.66188	1.5108	1.1992	1.8118	30
35	.55315	.83308	.66398	1.5061	1.2004	1.8078	25
40	.55436	.83228	.66608	1.5013	1.2015	1.8039	20
45	.55557	.83147	.66818	1.4966	1.2027	1.7999	15
50	.55678	.83066	.67028	1.4919	1.2039	1.7960	10
55	.55799	.82985	.67239	1.4872	1.2050	1.7921	5
34°00'	.55919	.82904	.67451	1.4826	1.2062	1.7883	56°00'
5	.56040	.82822	.67663	1.4779	1.2074	1.7844	55
10	.56160	.82741	.67875	1.4733	1.2086	1.7806	50
15	.56280	.82659	.68087	1.4687	1.2098	1.7768	45
20	.56401	.82577	.68301	1.4641	1.2110	1.7730	40
25	.56521	.82495	.68514	1.4595	1.2122	1.7693	35
30	.56641	.82413	.68728	1.4550	1.2134	1.7655	30
35	.56760	.82330	.68942	1.4505	1.2146	1.7618	25
40	.56880	.82247	.69157	1.4460	1.2158	1.7581	20
45	.57000	.82165	.69372	1.4415	1.2171	1.7544	15
50	.57119	.82082	.69588	1.4370	1.2183	1.7507	10
55	.57238	.81998	.69804	1.4326	1.2195	1.7471	5
35°00'	.57358	.81915	.70021	1.4281	1.2208	1.7434	55°00'
5	.57477	.81832	.70238	1.4237	1.2220	1.7398	55
10	.57596	.81748	.70455	1.4193	1.2233	1.7362	50
15	.57714	.81664	.70673	1.4150	1.2245	1.7327	45
20	.57833	.81580	.70891	1.4106	1.2258	1.7291	40
25	.57952	.81496	.71110	1.4063	1.2270	1.7256	35
30	.58070	.81411	.71329	1.4019	1.2283	1.7220	30
35	.58189	.81327	.71549	1.3976	1.2296	1.7185	25
40	.58307	.81242	.71769	1.3933	1.2309	1.7151	20
45	.58425	.81157	.71990	1.3891	1.2322	1.7116	15
50	.58543	.81072	.72211	1.3848	1.2335	1.7081	10
55	.58661	.80987	.72432	1.3806	1.2348	1.7047	5
	Cosine	Sine	Cotan.	Tan.	Cosec.	Secant	Angle

Table 14. Trigonometric Functions (Continued)

Angle	Sine	Cosine	Tan.	Cotan.	Secant	Cosec.	
36°00'	.58778	.80902	.72654	1.3764	1.2361	1.7013	54°00'
5	.58896	.80816	.72877	1.3722	1.2374	1.6979	55
10	.59014	.80730	.73100	1.3680	1.2387	1.6945	50
15	.59131	.80644	.73323	1.3638	1.2400	1.6912	45
20	.59248	.80558	.73547	1.3597	1.2413	1.6878	40
25	.59365	.80472	.73771	1.3555	1.2427	1.6845	35
30	.59482	.80386	.73996	1.3514	1.2440	1.6812	30
35	.59599	.80299	.74221	1.3473	1.2453	1.6779	25
40	.59716	.80212	.74447	1.3432	1.2467	1.6746	20
45	.59832	.80125	.74673	1.3392	1.2480	1.6713	15
50	.59949	.80038	.74900	1.3351	1.2494	1.6681	10
55	.60065	.79951	.75128	1.3311	1.2508	1.6648	5
37°00'	.60181	.79863	.75355	1.3270	1.2521	1.6616	53°00'
5	.60298	.79776	.75584	1.3230	1.2535	1.6584	55
10	.60413	.79688	.75812	1.3190	1.2549	1.6552	50
15	.60529	.79600	.76042	1.3151	1.2563	1.6521	45
20	.60645	.79512	.76271	1.3111	1.2577	1.6489	40
25	.60761	.79424	.76502	1.3071	1.2591	1.6458	35
30	.60876	.79335	.76733	1.3032	1.2605	1.6427	30
35	.60991	.79247	.76964	1.2993	1.2619	1.6396	25
40	.61107	.79158	.77196	1.2954	1.2633	1.6365	20
45	.61222	.79069	.77428	1.2915	1.2647	1.6334	15
50	.61337	.78980	.77661	1.2876	1.2661	1.6303	10
55	.61451	.78890	.77895	1.2838	1.2675	1.6273	5
38°00'	.61566	.78801	.78128	1.2799	1.2690	1.6243	52°00'
5	.61681	.78711	.78363	1.2761	1.2705	1.6212	55
10	.61795	.78622	.78598	1.2723	1.2719	1.6182	50
15	.61909	.78532	.78834	1.2685	1.2734	1.6153	45
20	.62023	.78441	.79070	1.2647	1.2748	1.6123	40
25	.62137	.78351	.79306	1.2609	1.2763	1.6093	35
30	.62251	.78261	.79543	1.2572	1.2778	1.6064	30
35	.62365	.78170	.79781	1.2534	1.2793	1.6034	25
40	.62479	.78079	.80020	1.2497	1.2807	1.6005	20
45	.62592	.77988	.80258	1.2460	1.2822	1.5976	15
50	.62706	.77897	.80498	1.2423	1.2837	1.5947	10
55	.62819	.77806	.80738	1.2386	1.2852	1.5919	5
	Cosine	Sine	Cotan.	Tan.	Cosec.	Secant	Angle

Table 14. Trigonometric Functions (Continued)

Angle	Sine	Cosine	Tan.	Cotan.	Secant	Cqsec.	
39°00'	.62932	.77715	.80978	1.2349	1.2867	1.5890	51°00'
5	.63045	.77623	.81219	1.2312	1.2883	1.5862	55
10	.63158	.77531	.81461	1.2276	1.2898	1.5833	50
15	.63270	.77439	.81703	1.2239	1.2913	1.5805	45
20	.63383	.77347	.81946	1.2203	1.2929	1.5777	40
25	.63495	.77255	.82190	1.2167	1.2944	1.5749	35
30	.63606	.77162	.82434	1.2131	1.2960	1.5721	30
35	.63720	.77070	.82678	1.2095	1.2975	1.5694	25
40	.63832	.76977	.82923	1.2059	1.2991	1.5666	20
45	.63944	.76884	.83169	1.2024	1.3006	1.5639	15
50	.64056	.76791	.83415	1.1988	1.3022	1.5611	10
55	.64167	.76698	.83662	1.1953	1.3038	1.5584	5
40°00'	.64279	.76604	.83910	1.1917	1.3054	1.5557	50°00'
5	.64390	.76511	.84158	1.1882	1.3070	1.5530	55
10	.64501	.76417	.84407	1.1847	1.3086	1.5503	50
15	.64612	.76323	.84656	1.1812	1.3102	1.5477	45
20	.64723	.76229	.84906	1.1778	1.3118	1.5450	40
25	.64834	.76135	.85157	1.1743	1.3134	1.5424	35
30	.64945	.76041	.85408	1.1708	1.3151	1.5398	30
35	.65055	.75946	.85660	1.1674	1.3167	1.5371	25
40	.65166	.75851	.85912	1.1640	1.3184	1.5345	20
45	.65276	.75756	.86165	1.1605	1.3200	1.5319	15
50	.65386	.75661	.86419	1.1571	1.3217	1.5294	10
55	.65496	.75566	.86674	1.1537	1.3233	1.5268	5
41°00'	.65606	.75471	.86929	1.1504	1.3250	1.5242	49°00'
5	.65716	.75375	.87184	1.1470	1.3267	1.5217	55
10	.65825	.75280	.87441	1.1436	1.3284	1.5192	50
15	.65934	.75184	.87698	1.1403	1.3301	1.5166	45
20	.66044	.75088	.87955	1.1369	1.3318	1.5141	40
25	.66153	.74992	.88213	1.1336	1.3335	1.5116	35
30	.66262	.74895	.88472	1.1303	1.3352	1.5092	30
35	.66371	.74799	.88732	1.1270	1.3369	1.5067	25
40	.66479	.74702	.88992	1.1237	1.3386	1.5042	20
45	.66588	.74606	.89253	1.1204	1.3404	1.5018	15
50	.66697	.74509	.89515	1.1171	1.3421	1.4993	10
55	.66805	.74412	.89777	1.1139	1.3439	1.4969	5
	Cosine	Sine	Cotan.	Tan.	Cosec.	Secant	Angle

Table 14. Trigonometric Functions (Continued)

Angle	Sine	Cosine	Tan.	Cotan.	Secant	Cosec.	
42°00'	.66913	.74314	.90040	1.1106	1.3456	1.4945	48°00'
5	.67021	.74217	.90304	1.1074	1.3474	1.4921	55
10	.67129	.74119	.90568	1.1041	1.3492	1.4897	50
15	.67237	.74022	.90834	1.1009	1.3509	1.4873	45
20	.67344	.73924	.91099	1.0977	1.3527	1.4849	40
25	.67452	.73826	.91366	1.0945	1.3545	1.4825	35
30	.67559	.73728	.91633	1.0913	1.3563	1.4802	30
35	.67666	.73629	.91901	1.0881	1.3581	1.4778	25
40	.67773	.73531	.92170	1.0849	1.3600	1.4755	20
45	.67880	.73432	.92439	1.0818	1.3618	1.4732	15
50	.67987	.73333	.92709	1.0786	1.3636	1.4709	10
55	.68093	.73234	.92980	1.0755	1.3655	1.4686	5
43°00'	.68200	.73135	.93251	1.0724	1.3673	1.4663	47°00'
5	.68306	.73036	.93524	1.0692	1.3692	1.4640	55
10	.68412	.72937	.93797	1.0661	1.3710	1.4617	50
15	.68518	.72837	.94071	1.0630	1.3729	1.4595	45
20	.68624	.72737	.94345	1.0599	1.3748	1.4572	40
25	.68730	.72637	.94620	1.0568	1.3767	1.4550	35
30	.68835	.72537	.94896	1.0538	1.3786	1.4527	30
35	.68941	.72437	.95173	1.0507	1.3805	1.4505	25
40	.69046	.72337	.95451	1.0476	1.3824	1.4483	20
45	.69151	.72236	.95729	1.0446	1.3843	1.4461	15
50	.69256	.72136	.96008	1.0416	1.3863	1.4439	10
55	.69361	.72035	.96288	1.0385	1.3882	1.4417	5
44°00'	.69466	.71934	.96569	1.0355	1.3902	1.4395	46°00'
5	.69570	.71833	.96850	1.0325	1.3921	1.4374	55
10	.69675	.71732	.97133	1.0295	1.3941	1.4352	50
15	.69779	.71630	.97416	1.0265	1.3960	1.4331	45
20	.69883	.71529	.97700	1.0235	1.3980	1.4310	40
25	.69987	.71427	.97984	1.0206	1.4000	1.4288	35
30	.70091	.71325	.98270	1.0176	1.4020	1.4267	30
35	.70194	.71223	.98556	1.0146	1.4040	1.4246	25
40	.70298	.71121	.98843	1.0117	1.4060	1.4225	20
45	.70401	.71018	.99131	1.0088	1.4081	1.4204	15
50	.70555	.70916	.99420	1.0058	1.4101	1.4183	10
55	.70608	.70813	.99709	1.0029	1.4122	1.4163	5
45°00'	.70711	.70711	1.0000	1.0000	1.4142	1.4142	45°00'
	Cosine	Sine	Cotan.	Tan.	Cosec.	Secant	Angle

Table 15. Decimal Equivalents of the Number and Letter Sizes of Twist Drills

No.	Size in decimals	No.	Size in decimals	No.	Size in decimals	No.	Size in decimals
1	0.2280	21	0.1590	41	0.0960	61	0.0390
2	0.2210	22	0.1570	42	0.0935	62	0.0380
3	0.2130	23	0.1540	43	0.0890	63	0.0370
4	0.2090	24	0.1520	44	0.0860	64	0.0360
5	0.2055	25	0.1495	45	0.0820	65	0.0350
6	0.2040	26	0.1470	46	0.0810	66	0.0330
7	0.2010	27	0.1440	47	0.0785	67	0.0320
8	0.1990	28	0.1405	48	0.0760	68	0.0310
9	0.1960	29	0.1360	49	0.0730	69	0.02925
10	0.1935	30	0.1285	50	0.0700	70	0.0280
11	0.1910	31	0.1200	51	0.0670	71	0.0260
12	0.1890	32	0.1160	52	0.0635	72	0.0250
13	0.1850	33	0.1130	53	0.0595	73	0.0240
14	0.1820	34	0.1110	54	0.0550	74	0.0225
15	0.1800	35	0.1100	55	0.0520	75	0.0210
16	0.1770	36	0.1065	56	0.0465	76	0.0200
17	0.1730	37	0.1040	57	0.0430	77	0.0180
18	0.1695	38	0.1015	58	0.0420	78	0.0160
19	0.1660	39	0.0995	59	0.0410	79	0.0145
20	0.1610	40	0.0980	60	0.0400	80	0.0135

## LETTER SIZES OF DRILLS

Letter	Size in decimals	Letter	Size in decimals
A $1\frac{5}{16}$	0.234	N	0.302
B	0.238	O $\frac{5}{16}$	0.316
C	0.242	P $2\frac{1}{16}$	0.323
D	0.246	Q	0.332
E $\frac{1}{4}$	0.250	R $1\frac{1}{8}$	0.339
F	0.257	S	0.348
G	0.261	T $2\frac{3}{16}$	0.358
H $1\frac{1}{8}$	0.266	U	0.368
I	0.272	V $\frac{3}{8}$	0.377
J	0.277	W $2\frac{5}{16}$	0.386
K $\frac{5}{16}$	0.281	X	0.397
L	0.290	Y $1\frac{3}{8}$	0.404
M $1\frac{3}{8}$	0.295	Z	0.413



Table 16. Cutting Fluid Recommendations

Where more than one recommendation is listed, first is generally preferable

Sever-ity	Type of operation	Ferrous over 70 %	Ferrous 50-70 %	Ferrous 40-50 %	Ferrous below 40 %	Non-ferrous over 100 %	Non-ferrous below 100 %
1	Broaching (internal)	ASF <sup>5</sup>	ASF <sup>5</sup>	ASF <sup>5</sup>	ASF <sup>5</sup>	EmH <sup>2,4</sup>	EmH <sup>4</sup>
2	Broaching (surface)	As above	As above	As above	As above	As above	As above
3	Tapping (plain)	ASF <sup>1</sup>	ASF <sup>1</sup>	ASF <sup>5</sup>	ASF <sup>5</sup>	EmH <sup>2</sup> ISF ASF <sup>3</sup>	EmH ISF ISF <sup>3</sup>
2	Threading (pipe)	ASM <sup>1</sup>	ASF ASM	ASF <sup>5</sup>	ASF <sup>5</sup>	ISF EmH <sup>2</sup> ASF <sup>1</sup>	ISF EmH ASF <sup>3</sup>
3	Threading (plain)	ASF <sup>5</sup>	ASF <sup>5</sup>	ASF <sup>5</sup>	ASF <sup>5</sup>	As above	As above
4	Gear shaving	ASF <sup>5</sup>	ASF <sup>5</sup>	ASF <sup>5</sup>	ASF <sup>5</sup>		
4	Reaming (plain)	EmH ASF	ASF <sup>1</sup>	ASF <sup>5</sup>	ASF <sup>5</sup>	EmH <sup>2</sup>	EmH ISF
4	Gear cutting	ASF ASM	ASF ASM	ASF <sup>5</sup>	ASF <sup>5</sup>	ISF	ISF
5	Drilling (deep)	ASF <sup>5</sup>	ASF <sup>5</sup>	ASF <sup>5</sup>	ASF <sup>5</sup>	ISF	ISF
6	Milling (plain)	EmH EmO	EmH EmO	ASF <sup>5</sup> EmH	ASF <sup>5</sup> EmH	EmH <sup>2</sup>	EmH
6	Milling (multiple cutter)	As above	As above	As above	As above	As above	As above
7	Boring (multiple head)	EmH	EmH	EmH ASF <sup>5</sup>	ASF <sup>5</sup> EmH	As above	As above
7	Multiple-spindle automatic screw machines and turret lathes (drilling, forming, turning, reaming, cut-off, tapping, threading)	ASF <sup>5</sup>	ASF <sup>5</sup>	ASF <sup>1</sup>	ASF <sup>5</sup>	ISF ASF <sup>3</sup>	ISF
8	High speed (light-feed automatic screw machines,—drilling, forming, tapping, threading, turning, reaming, box milling, cut-off)	ASF <sup>5</sup>	ASF <sup>5</sup>	ASF <sup>5</sup>	ASF <sup>5</sup>	ASF <sup>3</sup> ISF	ISF
9	Planing (shaping)	EmH	EmH	EmH	EmH	EmH <sup>2</sup>	EmH
9	Turning single point and form tools	EmH ASF	EmH ASF	ASF <sup>1</sup>	ASF <sup>5</sup>	EmH <sup>2</sup>	EmH
9	Drilling	EmH ASF	EmH ASF	ASF <sup>1</sup>	ASF <sup>1</sup>	EmH <sup>2</sup> ASF <sup>3</sup>	ISF EmH
10	Sawing (circular; hack)	EmH EmO	EmH EmO	EmH EmO	EmH EmO	EmH <sup>2</sup> EmO <sup>2</sup>	EmH EmO
10	Grinding (plain)	EmT EmO	EmT EmO	EmT EmO	EmT EmO	EmO <sup>2</sup> ASF <sup>3</sup>	EmO
10	Grinding (thread)	ASF	ASF	ASF	ASF	ASF <sup>3</sup>	

Symbols for cutting fluids: ASF Active sulfurized fatty mineral oil.  
 ASM Active sulfurized mineral oil.  
 EmH Heavy-duty emulsifiable or soluble oil, frequently containing additives.  
 EmO Opaque emulsifiable or soluble oil.  
 EmT Transparent emulsifiable or soluble oil.  
 IFM Inactive fatty mineral oil.  
 ISF Inactive sulfurized fatty mineral oil.  
 MO Straight mineral oil.

<sup>1</sup> Either a transparent or an opaque (black) oil may be used, depending upon the need for visibility during operation. Transparent and opaque oils of virtually identical characteristics are generally available.

<sup>2</sup> Due to fire hazard, the recommendations for emulsifiable oils do not apply if magnesium or magnesium alloys are to be machined.

<sup>3</sup> This recommendation for aluminum only.

<sup>4</sup> Concentration of emulsions depends upon broach size, as well as amount and nature of metal being removed.

<sup>5</sup> Active sulfo-chlorinated oils, usually transparent and generally similar in character to active sulfurized oils, may be used.

Courtesy of Shell Oil Company, New York, N.Y.

# Index

## A

- Abrasive tools, 427
- Alloy steels, 595
  - effects of alloying elements, 596
- Aluminum, 604
- Angle, pressure, gears, 363
- Angle plates, 41
- Angles, clearance, shaper cutting tools, 27
  - rake, shaper cutting tools, 28
- Angular indexing, milling machine, 264
- Angular milling, 177
- Angular milling cutters, 187
- Angular parallels, 41
- Annealing, 612, 624
- Approximate indexing in minutes, 265
- Arbors, 198
- Attachments for milling machine, 145
  - circular milling, 148
  - high-speed, 149
  - index centers, 145
  - rack, 149
  - raising block, 146
  - rotary, 148
  - slotting, 147
  - tilting table, 146
  - universal, 146
  - vertical-spindle, 146

## B

- Babbitt, 609
- Back rests, how to adjust, 473
  - use of, in grinding, 472
- Balancing grinding wheels, 442
- Band tools, blades, 550
  - setting up, 554
  - terminology, 544
  - types, 550

- Bed, planer, 87
- Bevel gears, 345, 368
- Bessemer process, 582
- Blast furnace, 573
  - charging, 574
  - tapping, 575
- Block, raising, 145
- Bolts, 96
- Bonds, grinding wheel, 434
  - resinoid, 435
  - rubber, 435
  - shellac, 434
  - silicate, 434
- Boring, jig borer, 166
  - milling machine, 243, 297
- Braces, 98
- Brass, 607
- Bronze, 606
- Brown & Sharpe cam lock, 200

## C

- Cam-action vise, milling machine, 219
- Cam milling, 332
  - machine setup, 334
  - use of rotary table, 339
- Carbide tools, grinding, 453, 454
- Casehardening and pack hardening, 623, 625
- Cast iron, 577
- Castings, process of making, 578
- Centerless grinder, parts, 495
- Centerless grinding, 492
  - advantages of, 493
  - features of, 493
- Centers, planer, 95
  - shaper-index, 42
- Change gears for spiral milling, 313
- Circular milling attachment, 148
- Circular pitch, gears, 352

- Clamp, U, 45
- Clamping, hints on, 104  
     of work, to milling machine table, 214  
     to shaper table, 44
- Clamping blocks, 97
- Clamps, 45  
     C, 46  
     double-finger, 46  
     finger, 46  
     gooseneck, 46  
     plain, 45  
     U, 45
- Clearance angles on shaper tools, 27
- Climb or down milling, 172
- Collet for taper-shank mills, 199
- Concave milling cutter, 189
- Constant-volume system, hydraulics, 536  
     shaper, 536  
     surface grinder, 538
- Control valve, hydraulics, 521
- Conventional or up milling, 172
- Convex milling cutter, 189
- Coordinates, jig borer, 164
- Cope, 579
- Copper, 601
- Corner-rounding milling cutter, 188
- Cutter central, locating, 246
- Cutter grinding, operation, 488
- Cutters, screw-on, and arbors, 202
- Cutting feed, analysis, 209
- Cutting fluids, 627  
     classification, 635  
     choosing correct, 636  
     desired characteristics, 628  
     functions, 631  
     types, 631
- Cutting speed, calculations, 208  
     milling machine, 206  
     planer, 119  
     shaper, 34
- Cutting tools, planer, 111
- Cutting tools, shaper, 25
- Cylindrical grinding, operation, 478
- D**
- Dead centers, advantages of, in grinding, 471
- Depth of cut, milling machine, 210  
     adjusting, 247  
     planer, 119
- Diametral pitch, 353
- Diamonds and diamond wheels, 451  
     advantages, 453  
     care, 453  
     use, 453
- Differential indexing on milling machine, 268  
     alternate method, 272  
     definition and notations, 271
- Direct indexing, milling machine, 257
- Direction of cutter and feed in milling machine, 211
- Dividing head on milling machine, 250
- DoAll Contour-matic sawing machine, 555  
     operating speeds, 557  
     table feeds, 557
- Dogs, toe, 42, 99
- Double-angle milling cutters, 187  
     operation of setting, 327  
     reasons for use, 324  
     use of right-hand and left-hand, 325
- Dovetails, measuring, 76  
     shaping, 73
- Drag, 599
- Dressers, grinding-wheel, 462  
     diamond, 464  
     directions for use, 466  
     mechanical, 463  
     precision, 463
- Drilling, jig borer, 166  
     milling machine, 243, 297
- Duralumin, 609
- E**
- Electric process of steelmaking, 589
- End mills, 183

External taper grinding, operation,  
481  
suggestions, 483

## F

Face grinding, operation, 486  
suggestions, 487  
Face milling, 177, 244  
Facing cutter, 186  
Feed, milling machine, 208  
conditions governing amount, 209  
planer, 119  
shaper, 16  
Feeds and speeds, planer, 91  
shaper, 34  
Finishing cut, milling machine, 211  
planer, 121  
Fixture, internal grinding, 401  
milling machine, 221  
Flanged vise, milling machine, 217  
Flasks, 579  
Fluting reamers and taps, 292  
cut-and-try method, 293  
layout method, 294  
Fly cutter, 189  
Footstock, Brown & Sharpe grinder,  
403  
Form milling, 177  
Friction cutting or sawing, 554

## G

Galling, 633  
Gang milling, 177  
Gear-generating methods, 385  
by hobbing, 387  
by pinion-shaped cutters, 385  
Gearing nomenclature, 355  
Gears, base circle, 363  
bevel, 345, 368  
angular, 346  
calculations, 374  
circular pitch, 352  
cutters, 364

Gears, cutting, 389  
attachment, 252  
methods, 349  
in milling machine, 378  
definitions, 344  
diametral pitch, 353  
helical, 348  
herringbone, 348  
internal, 347  
miter, 345, 369, 377  
pitch angle, 370  
pitch circle, 350  
pitch cylinders, 368  
pitch diameter, 370  
pressure angle, 363  
reasons for, 350  
spur, 344, 356  
shape, 359  
tooth parts, 351, 356  
types and uses, 314  
worm, 349  
Gib adjustments, reasons for, 9  
Grain size, grinding wheel, 430  
Grains, abrasive, function of, 432  
Grinders, 393  
centerless, 397, 492  
cutter and tool, 416  
cylindrical, 396  
piston, 399  
plain, 397  
roll, 398  
universal, 401  
form, 396  
gear, 412  
thread, 411  
internal, 396, 413  
plunge-cut, 396, 408  
camshaft, 410  
crankpin, 409  
piston, 399  
surface, 397, 414  
types of, 395  
Grinding, advantages of using dead  
centers, 471  
causes, of inaccurate work, 470

**Grinding, causes, of wheel loading, 170**  
 centerless, 192  
 cylindrical, 178  
 cutter, 488  
 external taper, 481  
 face, 486, 487  
 factors in successful, 458  
 internal, 484  
 kinds of, 457  
 roughing and finishing cuts, 474  
 setting, depth of cut, 469  
   wheel speeds, 467  
   work, 466  
   work feeds, 469  
 shoulder, 480  
 suggestions, 477  
 terms, 416  
 use of cutting lubricants, 475

**Grinding wheels, balancing, 442**  
 bonds, 434, 435  
 component elements, 428  
 cut-off, 442  
 dressers, 462-464, 466  
 faces, 441  
 grade, 435  
 grain size, 430  
 markings, 447  
 mounted, 441  
 mounting, 460  
 shapes, 436  
 specifications, 449  
 speeds, 450  
 structure, 436  
 truing and dressing, 462

**Grippers, 42**

**H**

**Hardening, heat, 615**  
 hints on, 617  
 Metcalf's experiment, 616  
 and tempering, theory of, 612

**Headstock, Brown & Sharpe universal grinder, 402**

**Heat, of chip distortion, 629**

**Heat, of deformation, 629**  
 of friction, 630

**Heat-treating operations, definitions, 624**

**Helix, 304**

**Helix angle, 317**

**High-speed milling attachment, 149**

**Hints, clamping, planer, 104**  
 shaper work, 51

**Hobbing, 387**

**Hobs, 350**

**Hold-downs, 42**

**Holding, face-milling cutters, 302**  
 straight-shank cutters, 201  
 work, for drilling, 286  
   in milling machine, 216  
   in planer, platen, 95  
   in shaper, 37  
   in vise, 216

**Horizontal cut, planer, 121**  
 shaper, 55

**Hydraulic oil requirements, 533**

**Hydraulic-power transmission, advantages, 504**  
 principles, 505

**Hydraulic press, 526**

**Hydraulic pump, 508**

**Hydraulic shaper, 22**

**Hydraulics, automatic control, 532**  
 constant-volume system, 536  
   shaper, 536  
   surface grinder, 538  
 elements, 508  
 variable-volume system, 539

**I**

**Inaccurate work, with grinding machine, 470**  
 with shaper, 47, 50

**Increment cut or unequal spacing, 294**

**Index centers, milling machine, 145**

**Index head, 250**  
 with bevel gears, 311

- Index head, care of, 298
  - graduating with, 276
  - for rotary milling, 287
  - with spiral gears, 312
- Indexing methods, 256
  - angular, 264
  - approximate method in minutes, 265
  - differential, 268, 271
    - alternate method, 272
  - direct, 257
  - simple, 259
- Internal grinding operation, 484
  - suggestions, 485
- Internal stresses, 101
- Iron ores, mining, 571
  - refining, 572
    - blast furnace, 573

## J

- Jacks, planer, 98
- Jig borer, 158
  - coordinates, 164
  - drilling and boring, 166
  - inserting shanks in spindle, 162
  - locating position of work, 163
  - making settings, 162
  - parts, 159-161
  - rotary table, 167
  - setting up work, 162
  - suggested order of operations, 165
- Jig grinder, 167

## L

- Laps and lapping, 497
- Laying out, 107
- Lead, 604
- Length of stroke, shaper, how to adjust, 53
- Leveling, 105
- Lubricating, cutter, 211
  - shaper, 10

## M

- Measuring, dovetails, 76
  - and gaging, 108
- Metal hand saws, 541
  - DoAll, 555, 557
  - features, 541
- Metal cutting, sources of heat, 629
- Metal-slitting cutters, 182
- Metallography, 611
- Metallurgy, atoms and their behavior, 566
  - definitions and scope, 565
- Metals, ferrous, 565
  - cast iron, 577
  - steel, 595
  - nonferrous, 601
    - aluminum, 601
    - babbitt, 609
    - brass, 607
    - bronze, 606
    - copper, 601
    - Duralumin, 609
    - lead, 604
    - Monel, 609
    - tin, 603
    - zinc, 603
  - properties, 566
    - definitions, 567
  - types, 568
    - brittle, 568
    - ductile, 569
    - tough, 568
- Metcalf's experiment, 616
- Methods, holding work (*see* Holding)
  - indexing, milling machine (*see* Indexing methods)
- Milling, angular, 177
  - rectangular piece, 240
  - square or hexagon, 282
- Milling cutters, 178
  - angular, 187
  - concave, 189
  - convex, 189
  - corner-rounding, 188

- Milling cutters, double-angle, 187,**  
     324, 325, 327  
     end, 183  
     facing, 186  
     fly, 189  
     how to mount, 235  
     material, 190  
     metal-slitting, 182  
     shell-end, 185  
     side, 183  
     T-slot, 186  
     tap and reamer, 188  
**Milling flutes, 177**  
**Milling machine, adjusting depth of**  
     cut, 247  
     arbors, 198  
     attachments (*see* Attachments)  
     boring, 297  
     cutting bevel gear, 378  
     fixtures, 221  
     mounting of work-holding devices,  
         222  
     safety, 157  
     types, 130  
         plain, 133  
         universal, 134  
         vertical, 134  
**Milling methods, 172**  
     climb or down, 172  
     conventional or up, 172  
**Modern planers, 85**  
**Module, 354**  
**Monel metal, 609**  
**Mounted grinding wheels, 441**  
**Mounting, grinding wheels. 460**  
     milling cutters, 235  
     work-holding devices, 222
- N**
- Normalizing, 612, 625**
- O**
- Open-hearth process, steelmaking, 584**  
**Openside planer, 85**  
**Operation sheets, cutter grinding, 488**  
     cutting spur gear, 289  
     cylindrical grinding, 478  
     external-taper grinding, 481  
     face grinding, 487  
     internal grinding, 484  
     metal sawing, cutting exterior con-  
         tours, 562  
         straight line, 561  
     milling spiral, 329  
     shoulder grinding, 480  
     straddle milling, 285  
     surface grinding, 489  
     vertical milling, 155
- P**
- Pack hardening, 623**  
**Parallels, 40**  
     adjustable, 70  
     angular, 41  
**Pitch, circular, gears, 352**  
     diametral, 353  
**Placing clamps and stops, 102**  
**Plain milling machine, 133**  
**Plain vise, milling machine, 217**  
**Planer, bed, 87**  
     centers, 95  
     cutting tools, 111  
     feeds and speeds, 91  
     gage, 109  
     jacks, 98  
     modern, 85  
     openside, 85  
     parts, 84, 86  
     platen, 88  
     poppets, 99  
     safety, 92  
     size, 83  
     stops, 99  
     toe dogs, 99  
     toolhead, 89  
     vise, 94  
     work, 93  
**Planing T slots, 124**

Platen, planer, 88  
Plates, angle, 41  
Poppets, planer, 99  
Positive stop, use of, 239  
Precautions in setting up milling machine, 230  
Preliminary hints on shaper work, 51  
Pressure angle, gears, 363  
Principles of hydraulics, 505  
Profiling, 177  
Profiling machine, 132  
Pumps, gear, 509  
    hydraulic, 508  
    plunger, 512  
    vane, 510

## R

Rack milling attachment, 149  
Racks and pinions, 349  
Raising block, 145  
Rake angle, shaper cutting tools, 28  
Resistance valve, 523  
Right-hand and left-hand cutters, 194  
Right-hand and left-hand tools, 30  
Rotary milling attachment, 148  
Rotary table, for jig borer, 167  
    used in cam milling, 339  
Roughing cut, planer, 120  
Routing, 178

## S

S.A.E. numbering system of steel, 595  
Safety, grinder, 457  
    milling machine, 157, 298  
    planer, 92  
Screw-on cutters and arbors, 202  
Selecting cutter for milling machine, 235  
Setting, feed trip, milling machine, 238  
    head for vertical and angular cuts, shaper, 59

Setting, speed and feed, milling machine, 237  
    tool, planer, 118  
Setting up job on milling machine, 232  
Shape of gear tooth, 359  
Shaper, causes of inaccurate work, 47, 50  
    construction, 1  
    cutting tools, 25  
    feed, 16  
    holding work, 37  
    hydraulic, 22  
    index centers, 40  
    lubricating, 10  
    names and functions of parts, 4  
    operation, 13  
        horizontal cut, 54  
    speeds and feeds, 36  
    starting, 12  
    tool head, 19  
    value, 2  
    vertical, 78  
    vise, 37  
    worktables, 17  
Shaping, with carbide tools, 28  
    dovetails, 73  
    irregular cut, 66  
    rectangular block square and parallel, 63  
    slots and keyways, 70  
    tongue and groove, 67  
    vertical and angular surfaces, 61  
Sharpening, cutters, 195  
    square-nosed tool for finishing cast iron, 58  
Shell-end milling cutters, 185  
Shims, 97  
Shoulder grinding, operation, 480  
    suggestions, 481  
Side-milling cutter, 183  
Simple graduating, 243  
Simple indexing, 259  
Size of planer, 83  
Slotting attachment, 147  
Speeds and feeds, planer, 91



Speeds and feeds, shaper, 34

Spiral, 304

angle, 317

circular pitch or normal pitch, 308

lead, 301

right-hand and left-hand, 306

shape of cutter for milling, 307

Spiral milling, calculating gears for, 315

change gears, 313

five features of, 305

gears necessary, 305, 309, 313

head, 252

operation sheet, 329

setting, cutter, 325

table, 306

short and long lead attachment, 320

using card furnished with machine, 321

Spiral-milling cutter, 324

Spur gear elements, 356

tooth parts, 351, 356

Steady rests, use of, in grinding, 472

Steel, alloy, 595

carbon in, 593

carbon tool, 615

high-speed, 598, 620

machine, 615

manganese, 594

phosphorus in, 594

S.A.E. numbering system, 595

sulfur in, 595

testing for hardness, 598

Steelmaking processes, bessemer, 582

electric, 589

open-hearth, 584

Stops, planer, 99

Straddle milling, 177, 284

Straps, 45

Stresses, external, 102

internal, 101

Swivel table, Brown & Sharpe universal grinder, 405

Swivel vise, milling machine, 218

## T

T-slot cutter, 186

Table, sliding, 407

swivel, 405

tilting, 116

Table stops, 111

Tap and reamer cutter, 188

Tempering, hints, 619

temper colors, 618

theory of, 612

Terminology, hand-tool, 544

Tilting table, 146

Tin, 603

Toe dogs, 12, 99

Tool head, planer, 89

shaper, 19

Tool lifter, planer, 124

Toolholders, 31

Toolmakers' universal vise, 230

Tools, carbide, shaping with, 28

cutting, planer, 111

shaper, 25

right-hand and left-hand, 30

Trip dogs, 143

Types of milling-cutter teeth, 179

formed, 179

saw, 179

## U

U clamp, 45

Unequal spacing or increment, 294

Universal milling attachment, 146

Universal milling machine, 133

parts, 134

Universal grinder, Brown & Sharpe,

401

Universal spiral index head, 252

Unwanted undercut, 239

## V

Valves, 516

control, 518, 521

Valves, piston-type, 517  
    resistance, 523  
Variable-volume system, hydraulics,  
    539  
Vertical cut, planer, 123  
Vertical milling machine, 149  
Vertical shaper, 78  
Vertical-spindle milling attachment,  
    146  
Vise, how to set parallel with direction  
    of stroke, 50  
    how to set square with direction  
    of stroke, 50  
    how to test seat, 47  
    how to test solid jaw, 49  
Vises, milling machine, cam-action,  
    219

Vises, milling machine, flanged, 217  
    plain, 217  
    swivel, 218  
    toolmakers' universal, 220  
planer, 194  
shaper, 37

**W**

Wet cutting, 444  
Wheel loading, causes of, 470  
Wide-range divider, milling machine,  
    278  
Worktables, shaper, 17

**Z**

Zinc, 603



