

CENTRAL LIBRARY

**Birla Institute of Technology & Science
PILANI (Rajasthan)**

796.32

Call No. B 43 M

Accession No. 46339

Acc. No.....

ISSUE LABEL

Not later than

latest date stamped below.

~~1 Dec 7, 5~~

~~10 Feb 76~~

~~30 Jun 76~~

THE CLAIR BEE BASKETBALL LIBRARY

BOOK III

MAN-TO-MAN DEFENSE AND ATTACK

The Barnes Sports Library

ARCHERY

ARCHERY by Reichart and Keasey

BADMINTON

BETTER BADMINTON by Jackson and Swan

BASEBALL

HOW TO PITCH by Feller

BASEBALL by Jessee

THE DICTIONARY OF BASEBALL

WITH OFFICIAL RULES by Cummings

BASEBALL TECHNIQUES ILLUSTRATED by Allen and Micoeau

BASKETBALL

DRILLS AND FUNDAMENTALS by Bee

MAN-TO-MAN DEFENSE AND ATTACK by Bee

THE SCIENCE OF COACHING by Bee

ZONE DEFENSE AND ATTACK by Bee

BASKETBALL ILLUSTRATED by Hobson

BASKETBALL by Murphy

BASKETBALL FOR GIRLS by Meissner and Meyers

BASKETBALL OFFICIATING by Tobey

BOWLING

BOWLING FOR ALL by Falcaro and Goodman

BOXING

BOXING by Haislet

CHEERLEADING

CHEERLEADING AND MARCHING BANDS by Loken and Dypwick

FENCING

FENCING by Vince

FIREARMS

RIFLE MARKSMANSHIP by Stephens

FISHING

HOW TO TIE FLIES by Gregg

BAIT CASTING by Robinson

BASS BUG FISHING by Brooks

FLY CASTING by Robinson

STRIPED BASS by Rodman

SURF FISHING by Evanoff

NATURAL FRESH WATER FISHING

BAITS by Evanoff

FOOTBALL

FOOTBALL by Killinger

TOUCH FOOTBALL by Grombach

SIX-MAN FOOTBALL by Duncan

FOOTBALL TECHNIQUES ILLUSTRATED by Moore and Micoeau

GAMES

LAWN GAMES by Tunis

GOLF

GOLF ILLUSTRATED by Berg and Cox

HANDBALL

FUNDAMENTAL HANDBALL by Phillips

HOCKEY

FIELD HOCKEY FOR GIRLS by Lee

ICE HOCKEY by Jeremiah

JIU-JITSU

JIU-JITSU by Lowell

PHYSICAL CONDITIONING

PHYSICAL CONDITIONING by Stafford and Duncan

RIDING

RIDING by Boniface

RIDING SIMPLIFIED by Self

ROPING

ROPING by Mason

SELF DEFENSE

SELF DEFENSE by Brown

SKATING

ROLLER SKATING by Martin

SKIING

SKIING by Prager

SOCCER

SOCCER by Fralick

SOCCER AND SPEEDBALL FOR GIRLS by Hupprich

SOFTBALL

SOFTBALL by Noren

SOFTBALL FOR GIRLS by Mitchell

SQUASH RACQUETS

SQUASH RACQUETS by Debany

SWIMMING

SWIMMING by Kiphuth

TENNIS

TENNIS by Jacobs

TENNIS MADE EASY by Budge

PADDLE TENNIS by Blanchard

TRACK AND FIELD

TRACK AND FIELD by Conger

VOLLEY BALL

VOLLEY BALL by Laveaga

This library of sports books covers fundamentals, techniques, coaching and playing hints and equipment, uniformly priced at \$1.50. Leading coaches and players have written these volumes. Photographs and drawings illustrate techniques, equipment and play.

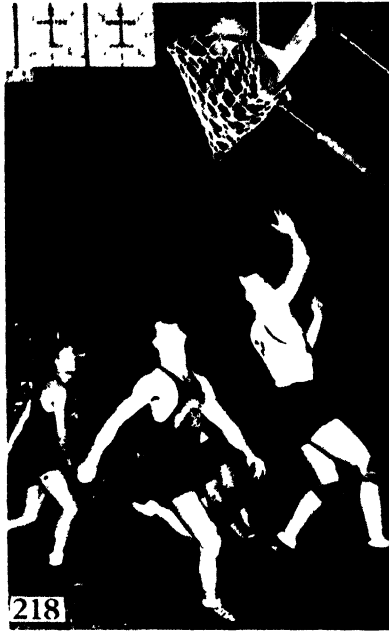

218. Julie Bender, L.I.U. high scorer, has just released a lay-up shot while traveling at full speed. Note the concentration on the target even after the ball has caromed from the backboard.

219. The high jump should be used in making the lay-up shot. Most players use a broad jump and thus lose control of the body.

Acme photos.

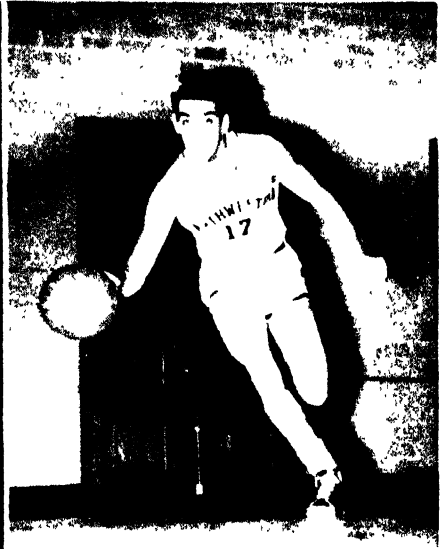

220. Lou Boudreau, star University of Illinois athlete, possessed good hands. He was a marvelous dribbler and here illustrates good form in possession dribbling. Note that Boudreau is keeping the head up, the body well over the ball, and controlling the ball with the fingers. *International News* photo.

221. Otto Graham, a great all-around athlete in his playing days at Northwestern University, demonstrates the dribble for speed. *International News* photo.

222—223. Dale Sears and Ralph Vaughn of the University of Southern California were coached by Sam Barry to keep the ball close to the floor.

The Clair Bee Basketball Library

BOOK III

MAN-TO-MAN
DEFENSE
AND
ATTACK



NEW YORK

A. S. BARNES AND COMPANY

COPYRIGHT, 1942, BY A. S. BARNES AND COMPANY, INCORPORATED

All rights reserved. No part of this book may be reproduced in any form, either wholly or in part, for any use whatsoever, including radio presentation, without the written permission of the copyright owner with the exception of a reviewer who may quote brief passages in a review printed in a magazine or newspaper.

Tenth Printing

PRINTED IN THE UNITED STATES OF AMERICA

To
ANGUS AND ARTHUR E. FRENCH

PREFACE

BASKETBALL DEFENSES range from man-to-man and zone to combinations and variations of each. All have a place in the game. The progressive coach will probably use either, both, a combination, or variation, depending upon his convictions and the abilities of the players who make up the squad.

This book deals expressly with the man-to-man defense, the variations which have developed therefrom, and various attack formations or styles of play for use against each defense. Especial attention is given to developments or revivals such as the pressing and screen-switch defenses as well as methods of meeting them.

The man-to-man defense and the variations which are outlined in this book will prepare a team to oppose efficiently any type of known offense. Team methods of shifting, switching, sliding, and floating are discussed to show how they may be used against certain attacks and in particular situations. Considerable attention is given to defenses for those teams which possess individual high scorers, an exceptionally tall pivot player, a dangerous quick-break, and other unusual attacks.

Offensive styles presented include, among others, post, double post, pivot, double pivot, combinations, and the use of screening. In each of the styles and attack formations attention is devoted to personnel and the abilities required for the several positions.

It is the belief of the writer that a defensive system can be developed over a period of time which will permit a representative team to use a number of defenses satisfactorily. This conclusion is based upon the premise that the players will first be grounded in man-to-man defense fundamentals. The writer has taught high school and college basketball and is of the opinion that the ability of any team to master more than one defense depends entirely upon the fundamental training of the individual player.

The high school boy of today is twice as versatile and accomplished as the player of fifteen or twenty years ago. It is not unusual to see high school football teams employ two or three types of defense, chiefly because the fundamental training underlying each is the same. This theory can be applied to basketball.

It may be interesting to list the defenses which were employed at Long Island University over a five-year period. All players were first taught the fundamentals of the man-to-man defense.

1937-38: Two-One-Two zone, Man-to-Man with Floating.

1938-39: Man-to-Man with Floating, Screen-Switch, Two-One-Two zone.

1939-40: Three-Two zone, Man-to-Man with Floating.

1940-41: Man-to-Man, Three-Two zone, Pressing.

1941-42: One-Three-One zone, Man-to-Man with Floating, Pressing.

INFORMATION CHART

OFFENSIVE COURT—Used when illustrating the attack.

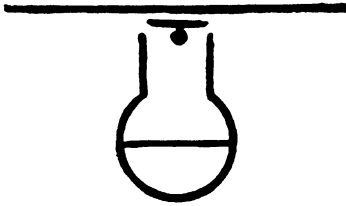

DEFENSIVE COURT—Used when illustrating the defense.

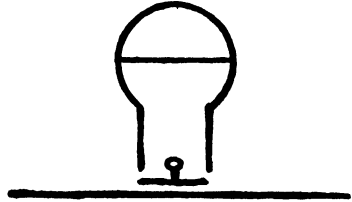

KEY TO DIAGRAMS

Official 

Ball 

Path of Ball - 

Bounce pass 

Path of Dribble 

Path of Player 

Pivot or Post Block 

PLAYERS	OFFENSE	DEFENSE
Left Guard	A	4
Right Guard	B	5
Center	C	1
Left Forward	D	2
Right Forward	E	3

An offensive man stationed on the free-throw line or opposite this line with his back to the basket is called a post player. An offensive player working near or under the basket facing the rear court is termed a pivot man.

CONTENTS

Preface	vii
Information Chart	viii
PART I. DEVELOPMENT OF THE MAN-TO-MAN DEFENSE AND ATTACK	
I. Introduction	i
II. Evolution of the Man-to-Man Defense and Attack	5
PART II. PRINCIPLES OF THE MAN-TO-MAN AND VARIATION DEFENSES	
& III. Team Principles of the Man-to-Man Defense	17
IV. Defenses for the Quick-Break	33
V. Variations of the Man-to-Man Defense	41
PART III. ATTACKING THE MAN-TO-MAN DEFENSE AND VARIATIONS	
VI. Offensive Principles and Screening Methods	49
VII. The Quick-Break	59
VIII. Meeting the Man-to-Man Variations	75
PART IV. OFFENSIVE FORMATIONS AND PLAYS	
IX. Single and Double Post Attacks	89
X. Single and Double Pivot Attacks	102

Part I. DEVELOPMENT OF THE MAN-TO-MAN DEFENSE AND ATTACK.

CHAPTER I

INTRODUCTION

"THE BEST DEFENSE is a good offense." This quotation has been used so frequently it is almost a proverb in basketball. However, there must be some semblance of balance between attack and defense or there can be no game. It is obvious that the development of an offense is more interesting and attractive than defensive work to players as well as coaches. Nevertheless, without defense the game would soon degenerate into a skills match.

ADVANTAGES OF A GOOD DEFENSE: The coach of a team which has been soundly drilled in defensive principles and tactics can view each game with a feeling of security. He may be sure that his team will always be in the running even though opposed by a better offensive opponent.

There are several psychological as well as practical advantages to the possession of a good defense, especially when playing away from home. Defensive measures are readily adaptable to the size of the floor, the lighting, and the background. The attack may be handicapped until the floor surroundings and atmosphere become familiar. During this time defensive strength may keep the game in hand until the attack can gain momentum.

A good defense is a weapon which will provide a team time to reorganize when its offense fails to click. Strong defensive teams are much respected by opponents. Every marksman, dribbler, deceptive or hard running player dreads to meet a guard who stops his specialty.

An opponent with a strong defense can demoralize a high scoring team which has been accustomed to a great number of shots and free movement about the court. Defense is not entirely confined to opposing the team with the ball. Defensive measures can be applied when a team is on the offense. The free scoring team can hardly wait until it regains the ball. When the opponents keep possession and employ delaying measures, mistakes are sometimes made by the high scoring team which further add to its discomfiture.

Perhaps the best time to impress the squad with defensive importance is at the first practice and during the early work-outs. The thought may strike home that the coach is a stickler for good defensive play. Furthermore, it is much easier to teach offensive principles after defensive measures have been thoroughly mastered than to reverse the process. For that reason the early practices should possibly stress defensive fundamentals to the neglect of the attack.

THE STEP-CHILD: In the early days of basketball the game was all offense. The chief principle was to score—"put the ball through the hoop." Defensive measures were confined to individual tactics, each player choosing an opponent and attempting to keep him from scoring. No cognizance was taken of balance, position, switching, or rebound work. Each player was assigned to an opponent and was not interested in the guarding difficulties of a teammate. However, as the game entered a more scientific stage, such defensive tactics were not always successful. For example, a slow man was often opposed to a speedy runner and in all-over-the-court action was left far behind when a dash the length of the floor occurred. This led to the matching of men, an important factor in the man-to-man defense.

"USE YOUR HEAD AND SAVE YOUR FEET": Professional play in early days, as today, was for the purpose of earning a livelihood. Day in and day out play of the game naturally meant wear and tear on the players. To conserve their legs and strength, the pros began to drop back to the middle of the court when they lost the ball and, from that position, picked up their respective opponents. This wall of defensive players was called the five-man one-line defense. It was followed in rapid succession by the position, five-man two-line, early territory zone, shifting zone, combination, screen-switch, pressing, and a great number of defense variations.

MAN-TO-MAN AND ZONE PHILOSOPHIES: This book is devoted to man-to-man defense. However, reference to the zone is not out of place. Contrasting theories of defense are a good thing for the game. If basketball was standardized a great deal of the attractiveness of the game would be lost. The use of different defenses provides opportunities for surprise and a change of tactics between and during games.

Comparing zone and man-to-man philosophies, it is difficult to assert which is correct in principle or superior in effectiveness. Man-to-man defense partisans oppose the zone defense because it masses in front of the basket in such manner that clever cutting plays are almost impossible. Zone enthusiasts retort that the man-to-man defense does likewise whenever it can. So far the battle has resulted in a stalemate; both defenses are popular and successful.

Whether one defense surpasses another in effectiveness depends upon many factors which are not present in a particular game. Most coaches agree that the attacking weakness of a certain opponent may make any defense look good. In most instances a statement of superiority is merely based upon personal opinion; who can say what coach is qualified to judge?

As the game is now played, each team secures the ball after opponents score. This means greater emphasis must be placed upon defensive play. Two teams evenly matched in offensive abilities and strategy could perhaps equal one another in scoring efforts. The influence of a better defense by one or the other would quite probably decide the victory.

Zone principles have influenced man-to-man defense chiefly through shifting, floating, and playing the ball. It may be wise to define the two major philosophies which are used in defensive basketball.

THE MAN: The primary responsibility in the man-to-man defense is an opposing player. Each defensive player is assigned to an opponent whom he will try to guard throughout the contest. This assignment, or matching of

men, is an important factor in man-to-man efficiency. Speed, scoring ability, and cleverness may be matched. In playing the opponent, the defensive man makes every effort to keep him from receiving, passing, or shooting the ball. In the attacking player's movements about the court, efforts are made to accompany him so closely that he cannot secure a good scoring position.

The ball is of secondary importance in the man-to-man defense and although an interception may be attempted, the defensive player is chiefly concerned with his opponent until a shot is taken or a loose ball occurs. It is necessary for each guard to concentrate on his assigned opponent because in most cases his teammates are too busy with their own guarding tasks to be relied upon for help. The modern development of the man-to-man defense enables teams to employ considerable defensive teamwork through switching, floating, and certain zone practices.

THE BALL: In the zone defense the players are chiefly interested in the ball. The man is of secondary consideration. Effort is made to keep between the ball and the basket so that an interception may be attempted at any time. Opponents are guarded only when they invade a particular territory or have the ball. A great deal of defensive teamwork is possible because each player slides from one territory to another, confident his teammates will support him in case an opponent with the ball manages to drive around him and toward the basket.

It is not the purpose of this text to make a comparison between the man-to-man and the zone defense. The majority of coaches feel that the man-to-man defense offers more advantages, providing the principles of shifting, switching, and floating are employed. Naturally the quality of the material available will have much to do with the successful use of any defense.

ADVANTAGES OF THE MAN-TO-MAN DEFENSE: A few advantages of the man-to-man defense follow. First, opponents may be matched according to their individual abilities (this requires scouting information or game observance, after which a change can be made). The development of guarding pride is not a small part of defensive psychology; each man is aware of his personal defensive job. Second, it fixes responsibility. Coach and teammates are able to recognize individual laxity in guarding assignments. If a player is over-matched or cannot cope with the speed of an opponent, the proper shift of men or a substitution can be made. Third, it encourages individual development of skills such as balance, footwork, use of hands, and the coordination required in switching. Fourth, it is adaptable to any type of offense, particularly those which employ delayed and spread tactics. Fifth, its use is absolutely imperative in the closing minutes of a game when a team is behind in the score. Sixth, it enables the defense to take advantage of offensive weaknesses on the part of certain individual opponents. (The defensive player assigned to the weak attacking opponent can float away from him for interceptions or to double-team a stronger player.)

DISADVANTAGES OF THE MAN-TO-MAN DEFENSE: The man-to-man defense requires experience and a thorough understanding of defensive fundamentals. Therefore considerable mental concentration is necessary. It is susceptible to screens, blocking, and other offensive tactics which, unless switching principles have been expertly developed, will result in scoring by the opponents. Because of the personalized matching of men more fouls will occur. The

quick-break cannot be used as efficiently. Interceptions are infrequent because each player concentrates on his opponent.

STRICT MAN-TO-MAN DEFENSE: The man-to-man defense may require the strict assignment of each defensive player to an opponent with definite instructions that he shall at no time leave his man. Not only is this opponent to be kept from scoring, but the guard may be instructed to concentrate so thoroughly that his competitor cannot get in position to receive the ball. Should the offensive player secure the ball, the guard must play him so closely that the opponent finds it is difficult to make a pass. The guard might be further instructed not to try for interceptions but to "dog" his opponent incessantly. This type of defense is, of course, extremely rigid and unusual.

VARIATIONS: Changes may be made in either basic defense which leave it unrecognizable. The strict man-to-man defense is subject to a number of variations. These variations may incorporate the switch when a block or screen occurs, floating away from an offensive opponent when ball and action are concentrated on the opposite side of the court, or aggressively playing both the man and the ball with the definite object of making interceptions. Other changes are those which combine zone and man-to-man tactics. The screen-switch defense falls into this class. It has adopted a number of zone as well as man-to-man principles.

WITHOUT RULES THERE CAN BE NO GAME: It has not been possible to stabilize offense and defense. First the offense has gained the advantage and then the defense. In one period defensive measures became so strong that spectators did not care to watch the game. In attempting to assist the offense, certain liberties were taken with the rules with the result that the game possibly became too free. This statement is made advisedly because spectators who support the game financially much prefer the high scoring contest.

CHECKMATE: When two expertly coached teams meet, the contest resembles a game of chess. The attack by one is countered by the defense of the other, which may range from a strict man-to-man defense to a zone or combination of both. Whether or not this matching of strengths is good for the game is a matter of opinion. Undoubtedly there are fans who appreciate the fine play of a defensive team, just as innumerable spectators thrill only to a high scoring attack.

Defensive play can be as interesting to watch as the attack. The open game which is so popular creates numerous situations in which one defensive man is opposed to a number of opponents. He must make lightning decisions and moves which should provide plenty of action for the fan or the spectator.

The coach should recognize the strengths and weaknesses of each type of defense, even though he may believe only in one style. His team will be called upon to oppose, at some time or other, a great number of varying defenses and will profit by preparedness. Furthermore, there is considerable enjoyment for coach and player in mastering the principles of a wide range of defenses.

The value placed upon defensive play by the coach will influence the boys who play for him. Use of any defense depends chiefly upon the abilities of the players and the defensive philosophy in which the coach believes.

CHAPTER II

EVOLUTION OF THE MAN-TO-MAN DEFENSE AND ATTACK

THE FIRST OFFENSE: In his original description of the game, Dr. Naismith described the offense when he said, "The object of the game is to put the ball into your opponent's goal."¹ Most coaches prefer to make his definition perfect by adding, "More often than the opponents." Early basketball attempted to follow the advice as quickly as possible. The quick-break was the most obvious and successful method then; it is today. When a player secured the ball he passed to a teammate stationed near the basket and this player attempted the score. This inaugurated the long pass and the quick-break became the first offense.

THE FIRST DEFENSE: Dr. Naismith planned original basketball defense on a man-to-man basis. Defensive players were instructed to "stick to your man like glue, follow him anywhere so as to prevent his receiving, passing, or shooting the ball."² This original defense was applied all over the court and resembled a mad scramble which could be compared to the game which results at present when two teams use the pressing defense.

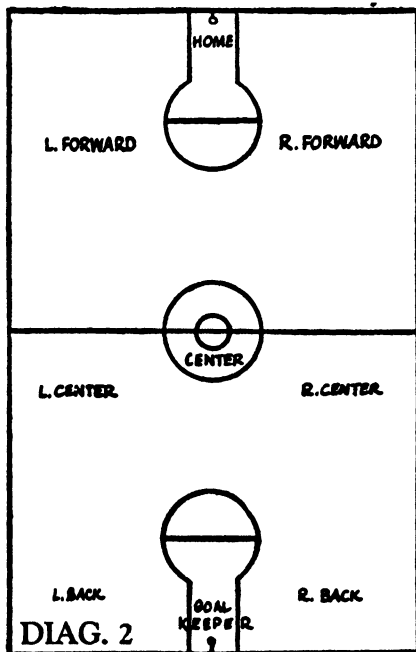
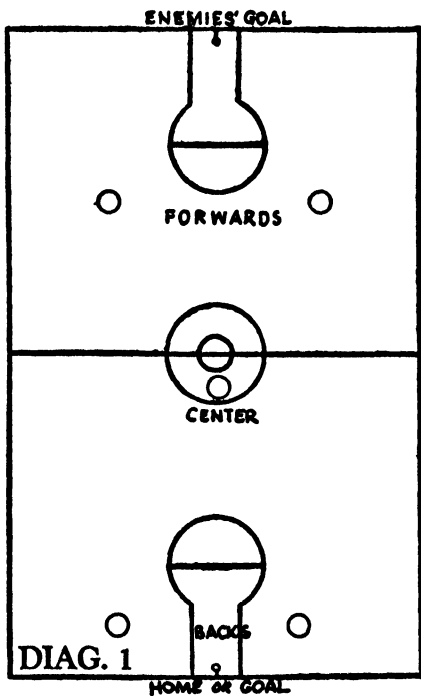

¹ James Naismith, *Basketball*, Spalding's Athletic Library, 1894, p. 12.

² *Ibid.*, p. 16.

PLAYER POSITIONS: In the first basketball guide (Spalding's 1893-1894), the inventor of the game included two diagrams showing the position of the players for five- and nine-man teams.

THE FIVE-MAN TEAM: Diagram 1. The positions for a five-man team are outlined. This team consisted of the center, two forwards, and two backs. Five-man teams were recommended for championship games while nine-man teams were advised for large courts.

THE NINE-MAN TEAM: Diagram 2. The outline for nine-man teams is reproduced. It will be noted that three men are stationed in scoring territory (home, left, and right forward), three in the center or intermediary area (center, left and right center), and three in the defensive part of the court (goal-keeper, left and right back).

Under the revised and copyrighted rules of 1893 (rule 21), the number of players was regulated. The team was to consist of five men when the actual playing space was less than 1200 square feet, and nine men when it was more than this and less than 3600 square feet.

These outlines resulted in a semblance of offensive and defensive teamwork. The defense was a man-to-man type with opponents checking one another closely at all times. When the backs, assisted by the goal-keeper, recovered the ball under their opponent's basket, they threw it to one of the center men. The center men passed in turn to their offensive teammates situated near the basket. These players, known as the forwards and "home" (in the case of a nine-man team), attempted to score. The opposing backs and "goalie" tried to stop these scoring efforts and upon securing the ball reversed the procedure. This was the first method of offensive and defensive play. Out of it grew the many and varied styles now popular.

For a year or two the players remained generally in the territories shown in Diagram 1. Close guarding, however, soon forced the guards to venture up-court to support their teammates. This was not so important when there were nine players on a side, but when the rules were changed in 1897 limiting teams to five players, the backs or guards were forced to enter the front court and assist in the scoring.

MAN-AHEAD-OF-THE-BALL: Center tap plays were popular early in the game and all members of the team took part in their execution. The success of center plays encouraged teamwork. It was not surprising that the players soon developed simple plays. When a score did not result from the center tap, forwards and center combined to develop the first passing play in basketball, the triangle. (Original passes resembled the baseball catcher's throw or "peg.")

The triangle was so known because player and ball movement formed a triangle. A player would pass the ball to his teammate and cut toward the basket. His teammate would return the ball to him and a triangle resulted, made up on two sides by the movement of the ball and on the third side by player movement. This play formed the basic principle from which the give-and-go (professional type) developed. It was also the forerunner for the most common offensive play in basketball, the screen.

Diagram 3. The triangle play is represented here. A passed the ball to B and cut for the basket. He was, therefore, ahead of the ball. The original pass and the path A took afterwards represented two sides of the triangle

and the third side was formed by the passing of the ball from B to A as shown.

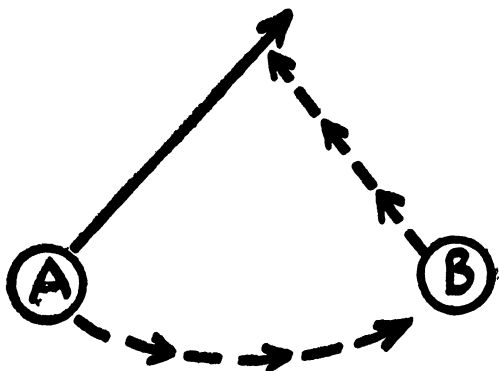

DIAG. 3

In addition to the center tap and triangle, out-of-bounds and held-ball plays became common. Practically all of these were based upon the principle of man-ahead-of-the-ball.

DEFINITION: Man-ahead-of-the-ball means a player cuts in the direction of the basket while a teammate with the ball is behind him in the rear court. This rear court feeder attempts to pass the ball to the cutting player for a score.

THE "SLEEPER" OFFENSE: The "sleeper" offense developed after the player position style, influenced by the early rule book diagrams, proved out of date. In this offense the center was used under the offensive basket and seldom retreated further in defensive territory than the center of the court, where he was usually opposed by the standing guard of the opponents. His teammates would secure the ball and throw it rapidly to this basket-hanger by means of a long pass or, if this was impossible, advance up the court until such time as the sleeper could break out from under the basket and receive the ball. The forwards would then cut around him for return passes. Occasionally the center would catch the ball, pivot, and dribble in for a score. (The first use of the post or pivot.)

DEFENSE FOR THE SLEEPER OFFENSE: The defense countered this sleeper offense by stationing a guard under the basket to play the basket-hanger.

COACHING METHODS: Coaching in the early days was devoted to the play of the individual, the qualities desirable, and the abilities regarded as most efficient in the specialized position.

DEFENSE DEVELOPMENT: When the offense began assembling its players in the front court, the defense began to mass its men in front of the basket. This required maneuvering on the part of the offense and laid the foundation for the set attacks which were soon to appear.

RETREATING MAN-TO-MAN DEFENSE: When the guards moved forward to help in the scoring, one assumed the duties of the standing guard while the other was known as the running guard and generally assisted in feeding and scoring. However, it often developed that the standing guard would be attacked by two or more opponents because teammates were outrun or

were caught out of position. This encouraged the assignment of two players to the defense while their three teammates devoted their efforts to scoring. As the offense became more effective, three players were used defensively and eventually five. Teams then began to retreat as a unit when the ball was lost and adopted the formation recommended in the early description of the game, or formed a straight line across the floor and waited for their respective opponents.

SINGLE LINE PROFESSIONAL STYLE: This defense was popular with professional players. Although there was some confusion when the offensive team arrived near the line of defense, professional players were so adept in shifting and maneuvering that it served their needs satisfactorily. The chief disadvantage where amateur players were concerned existed in the time required to master the individual skills. Such skills come with experience and the professional players had more opportunity to develop than the college or high school boy who was immature and new at the game.

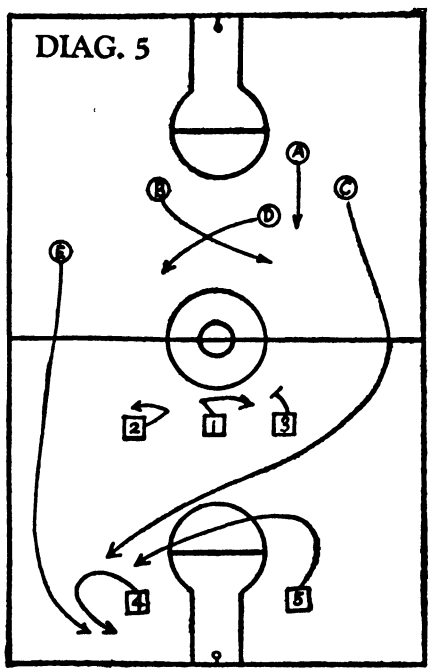
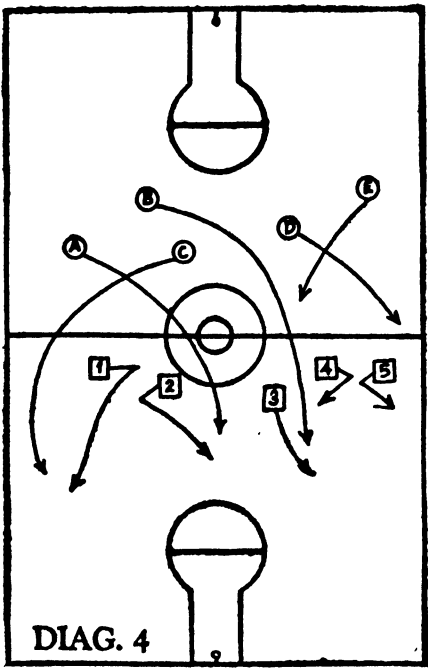

Diagram 4. The professional players did not find it difficult to shift opponents in this early defense. After forming their "wall" across the floor, they shifted men when the attacking players began to criss-cross while coming up the court. In this illustration A, B, C, D, and E were originally opposed by 1, 2, 3, 4, and 5, respectively. The shifting occurred as outlined. Defensive player 1 shifted to C, 2 to A, 3 to B, 4 to E, and 5 to D.

FIVE-MAN DEFENSE: This defense developed shortly after teams began to retreat upon losing the ball. It was a position defense and has often been referred to as the original zone. As the zone is known today, the five-man defense could be compared to it in only one feature—the positions assumed

in the formation. No operation principles of the zone were employed except the possible freedom the two guards enjoyed pending a cut by opponents through the front line of the defense. (The front line allowed two attacking players to enter the front court unmolested. These opponents were then played by the guards.)

The starting position of the five-man defense resembled the starting position of a Three-Two zone; thereafter all likeness disappeared. The two-line position was assumed pending the arrival of attacking opponents, whereupon man-to-man principles became effective.

Diagram 5. Two methods were used in the operation of the five-man defense. In the first, two of the attacking players were permitted to cut through the first line of defense and were immediately played man-to-man by the guards no matter where they went. The third opponent to approach was chosen by the closest defensive man in the front line and thereafter played man-to-man irrespective of his travel. This continued until each defensive player had chosen an opponent.

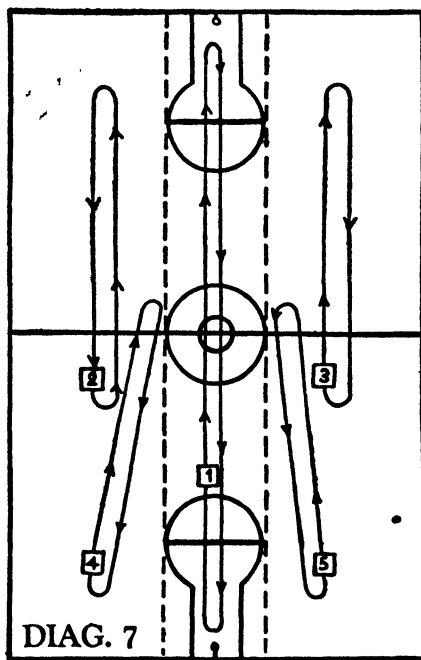
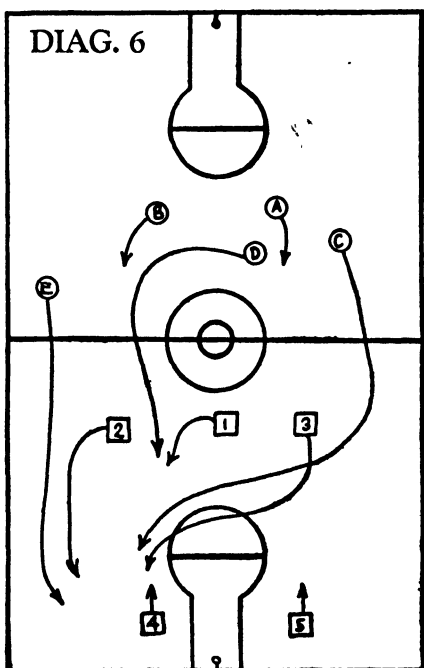

Diagram 6. In the second method the first three opponents were played by the center and the two forwards, leaving the two guards last to assume defensive duties. When the first line was vacated by the center and the two forwards, the guards were forced to advance to meet the two remaining opponents.

DELAYED ATTACK: Shortly before 1910 changes in defensive and offensive teamwork became noticeable. Although the quick-break was the background for most plays, the game was no longer a mad dash from one end of the floor to the other. A number of teams had begun to slow up their attack when it was impossible to work directly to a score after recovery of the ball.

The professional teams began to use this delayed attack for a number of reasons. First, professional basketball demanded consistent play. Second, day after day play of the game was exacting a toll upon stamina and legs. Third, each player wanted to extend his playing days as long as possible—continued hard running would soon “burn” him out. This slowing down of the game forced the “pros” to devise plays for scoring instead of beating the opponents to the basket.

The Combination Offense and Defense

POSITION STYLE: Although the defense was still man-to-man, a new position offense and defense began to make its appearance (about 1909). This new development was really an elaboration of the original position defense involving several principles which are now recognizable as zone in character.

A few quotations from “How to Play Basketball” may be interesting. “The position style of game which is rapidly growing in favor in the Eastern part of the United States allows the men more time for rest, not compelling them to follow an opponent who is not in possession of the ball.”³ This definitely established the principle of fixed territory common to early zone defenses.

“The floor is divided off by imaginary lines into three parts. The center space is narrower and the fastest man on the team must play here. He must have as nearly as possible the qualities of a center, forward, and guard combined. The entire team shifts its position as a whole up the floor when on the offense and reverses the process when on the defense.”⁴

Diagram 7. It can be readily determined that a forward shift of the team resulted in several types of the delayed offense. The guards and forwards would naturally remain in their respective territories but the offense would vary from a Three-Two, Two-One-Two, or to a Two-Three formation, depending upon the movement of the center in the middle space.

On the defense the team could retreat as a whole, resulting in a formation resembling the Three-Two, Two-One-Two, and the Two-Three zones, depending again upon the position of the center. (Note the defensive rebound-triangle formed by players 1-4-5 under the basket.)

The Zone Defense

TERRITORIAL: The zone defense in its original form was strictly territorial. It developed as a result of the original position defenses and because the retreating and five-man principles had proved effective in meeting massed attacks. It followed the position outline used in the five-man defense.

SHIFTING: When blocking began to disrupt the man-to-man defense the zone effectively met the challenge. It availed little to block an opponent who concentrated on the ball and did not follow a cutting teammate. The screening offense also proved dangerous until the zone defense was applied.

³ G. N. Messer, *How to Play Basketball*, Spalding's Athletic Library, 1911, p. 75.

⁴ *Ibid.*, p. 77.

However, the offense countered by overloading territory zones and outnumbering the rebound-guards. This forced the front line zone players to drop back on the side away from the ball to help out. It was soon found that the entire front line could retreat near the free-throw line and this led to the development of vertical shifting.

INFLUENCE OF ZONE PRINCIPLES ON MAN-TO-MAN DEFENSE: Lateral shifting soon followed because of offensive overloading of certain zones. The man-to-man defense then began to divide its attention between the man and the ball. This was a violation of all previous man-to-man principles. The rule since the first day of the game was to play the assigned opponent so he could not get into position to receive the ball, pass the ball to a teammate, or take a shot. In the early days when so little attention was paid to individual defensive principles, it is obvious that the task kept the defensive player pretty well occupied. Dividing his interest between the opponent and the ball opened up the game considerably and permitted more interceptions and therefore the defensive trend gained in popularity with the players.

FLOATING: Shifting by zone players developed a strong weapon for the man-to-man defense—floating. Floating occurs when a defensive player moves away from his opponent, vertically or laterally, in order to congest an area in which the attack is concentrating.

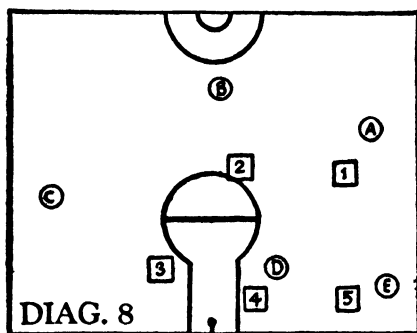

Diagram 8. The defensive team is applying the man-to-man defense combined with floating. The ball is in the possession of A, who is opposed by defensive player 1. Since the ball is on that side of the court, 4 and 5 are guarding D and E closely. Defensive teammates 2 and 3 are floating away from their opponents to assist in congesting the scoring area in front of the basket, 2 floating vertically and 3 laterally. While floating, 2 and 3 watch their respective opponents closely, prepared to cover them should they receive the ball, change position, or cut to the basket.

OFFENSIVE AND DEFENSIVE PRINCIPLES: The degree of passiveness or aggressiveness with which a man-to-man or zone defense is applied is termed offensive or defensive. Offensive means defensive players will take chances in an attempt to secure the ball; opponents will be harried at all times and, when a shot is taken and before it has scored or rebounded, defensive players will break for their basket. Defensive means just the opposite—possession will be assured before any move is made to attack.

THE STALL: Because the defense massed under the basket and used shifting zone principles, which practically eliminated the possibilities of a close shot,

the offense began to withhold the ball from play. This resulted in conflicts of opinion, 1 to 0 scores, bad feelings between schools, coaches, and legislators, and ruination of spectator interest. Something had to be done. Although most coaches and legislators agreed with Dr. Naismith that the burden was upon the defense in such a situation, the ten-second rule was passed. This required the offensive team to advance the ball across the center of the court within ten seconds (1932). Dr. Naismith believed the wrong team was being penalized: "The offense should be allowed to do whatever it wishes." He argued, "It's the defense that should be required to come out and try to take the ball away."⁵ You may disagree with him, but he invented the game.

BALL-AHEAD-OF-THE-MAN: A number of years after the delayed attack developed, an important offensive device was developed by Leonard "Dutch" Dehnert, center of the famed Celtic basketball team. In one of their road games the Celtics were far ahead in the score and decided to move the ball around without further adding to the ignominy of their opponents. Dehnert stationed himself on the free-throw line and the ball was shuttled in and out between him and his teammates. The idea was not new since the tactics of the "sleeper" play included this weapon, but Dehnert added to its effectiveness because of his marvelous passing ability.

The Celtics decided to try out the idea, using Dehnert as a post around which to cut. It proved effective and soon became part of their regular set offense. Dehnert made no attempt to score from the post position but used it as a feeding medium for cutting teammates. No player has ever approached Dehnert's marvelous passing ability but styles of play based upon use of the post developed from the idea and this principle is reflected in ball-ahead-of-the-man.

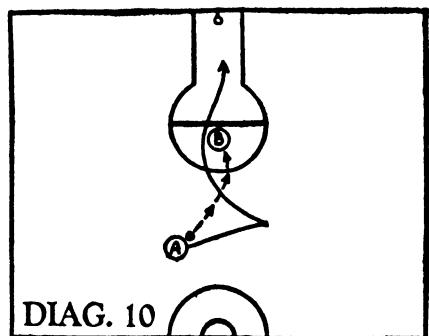
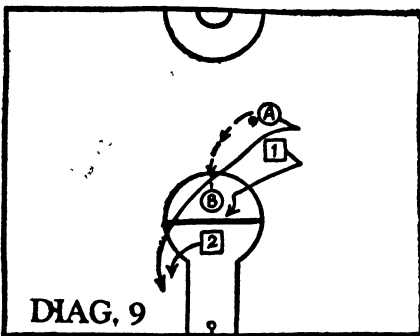

THE SWITCH: Diagram 9. Ball-ahead-of-the-man was presently countered by the development of the switch as shown. However, this switching problem is still a troublesome one; attacks are now directed toward the switching defensive player instead of the man being run into the block. The attacking player A passed the ball to B, feinted to the left, and cut as shown. The purpose was to confuse opponent 1. Defensive player 2 saw his teammate 1 might lose his opponent, called "switch," and thereafter guarded A. Defensive player 1 then shifted his guarding responsibilities to player B.

⁵ *New York World Telegram*, January 31, 1939.

Diagram 10. Ball-ahead-of-the-man comprehends a player near the basket or ahead of his teammates. He may be moving or in a stationary position (post or pivot). The ball is passed to this pivot player, who may shoot or pass to teammates cutting toward him. Both principles are basic in developing an attack. A passed the ball to B. The ball was, therefore, ahead of the man. A can cut in any number of directions toward the ball and it will be returned to him if he succeeds in eluding his opponent.

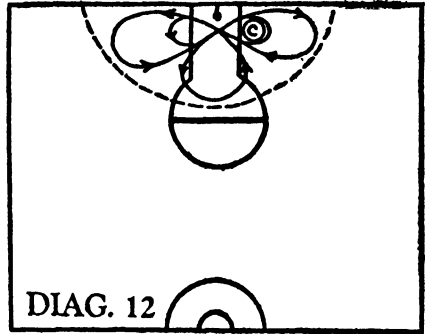
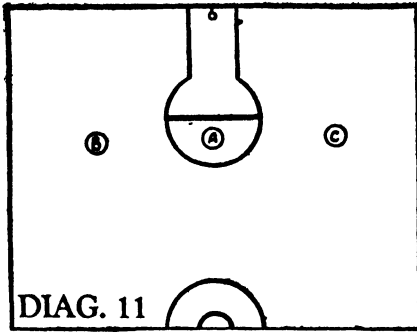

THE POST POSITION: Diagram 11. A post player is one who stations himself on or near the free-throw line and handles the ball from this position in attacking the zone or man-to-man defense. An offensive formation may include one or more of these post players. Post players A, B, and C occupy positions near which post attacks start. A post attack may consist of one, two, or three men who can be stationary or moving.

THE PIVOT POSITION: Diagram 12. A pivot player maintains a more or less set position under or near the basket. He is usually concerned, first, with shooting and, second, with feeding cutting teammates. There may be two or three such players near the basket. A number of formations and styles of play have been developed around the use of these pivot men. The formation can comprehend vertical or lateral alignment when two or more pivot players are used.

BLOCKING PRINCIPLES: When the delayed game became popular, coaches and players began to use illegal means to increase its effectiveness. Basketball plays were drawn up more or less in football style. Players were coached to move into certain positions whereby a designated opponent found it impossible to follow the blocker's teammate. Each offensive player had a certain position to attain and a clearly defined blocking task to perform, often identified by signals as in football. This type of offense violated every concept of the game but endured for a number of years. Naturally the defense countered by use of some form of the zone or the switch defense. Rules legislation also checked the efficiency of blocking, albeit belatedly. Deliberate blocking is unusual at present.

Blocking is impeding the progress of an opponent, usually by physical contact. Such tactics are performed deliberately, the blocking player making no effort to blend into the general pass play of his team in order to secure the ball and score.

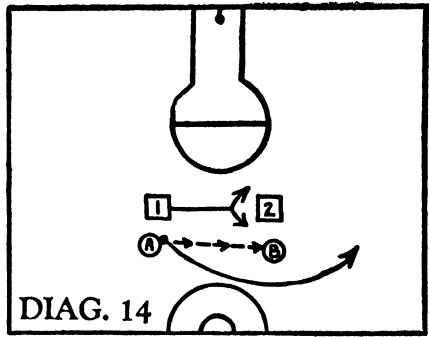
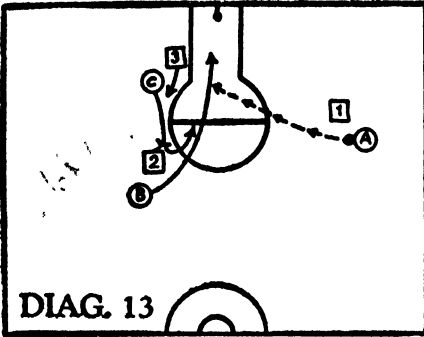
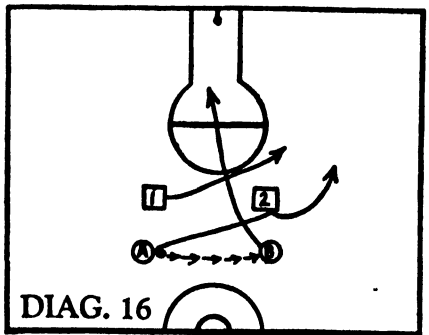
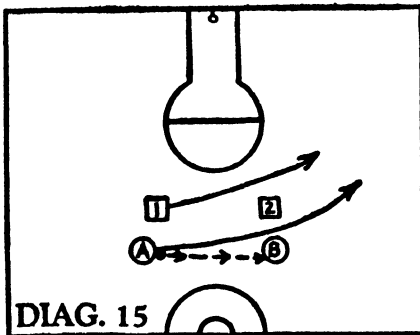

Diagram 13. The ball is in the possession of A. Attacking player C moves to a close position behind defensive 2 so that contact will result when a cut toward the basket is made by B. B suddenly cut to the basket and 2, attempting to follow him, bumped C and was delayed long enough for B to gain a step or two advantage.

SCREENING PRINCIPLES: Screening occurs when an offensive player moves between a teammate and his opponent in such a manner that no contact results. The screen principles were first designed so a player could maneuver a teammate between himself and his respective guard. The old and familiar axiom was, "Pass and go behind your teammate." With the development of block plays the method was reversed. Players were taught to form a screen for a teammate. More often than not, this screen called for contact. It was such use of the screen which caused the controversy between Eastern and Western coaches. Contact often occurred when an attacking player attempted to pass between a teammate and his respective opponent and not infrequently the defensive player moved into the path of the screening player in order to "draw" a foul. Screening methods at present cause little difficulty except where contact is deliberately encouraged.

ORIGINAL SCREENING: Diagram 14. A passed the ball to B and cut behind him. Defensive player 1 was forced to slide in front or behind his teammate 2.



LEGAL SCREEN: Diagram 15. Player A passed the ball to B and cut in front of 2 without contact. In case 2 should move toward his opponent (B), the official would probably hold A responsible for any contact which resulted

since B has the ball. However, the foul which would result from contact might be called upon either player, depending upon the official's judgment.

ILLEGAL SCREEN: Diagram 16. A passed the ball to B and cut toward defensive player 2 in a straight line and contact resulted. Since it appears that A made no attempt to change his path in screening between B and 2, he has caused the contact and should be charged with a foul. A can eliminate this foul in several ways: by stopping, using a forward or backward spin, or changing direction.

SCORING METHODS: The original quick-break encouraged close basket scoring. Short shots predominated then as today. When the defense first assembled under the basket to oppose massing by the offense, attacking players countered by retreating a short distance and using set-shots. However, the influence of the close shot has remained in basketball and it is the exceptional team rather than the usual team which relies upon distance shooting. Probably the well-rounded attack will include both the short and the long shot.

A number of coaches are opposed to the long shot because of the decrease in accuracy which accompanies an increase in distance. It might be well to consider the advantages which often accompany the long shot. For example, a great number of teams mass under the basket and interfere little with opponents situated some distance from the basket before or after they receive the ball. This allows plenty of time to aim and attempt the shot. The stationary position also has an advantage over movement in marksmanship and undoubtedly two hands are better than one. (Close shots are usually made with one hand while cutting at top speed.)

PASSING METHODS: Early passing technique stressed the long pass because of the quick-break. This long pass is still an important factor in the success of most quick-break styles. With the development of the triangle play, short passes became important. At first these passes were more or less simple in execution but professional players began to experiment with deception and it was not long until a great variety of passes became common.

Certain types of passes blend perfectly with offensive styles of play. For example, in the screening or give-and-go attack, the snap, hook, back bounce (one-hand and two-hand), over-the-shoulder, and the one- and two-hand back flips are passes which blend perfectly. Conversely, in using a pivot offense the two-hand overhead, baseball, two-hand cross, one-hand bounce, hook, and the behind-the-back pass may be more effective.

THE DRIBBLE: Dr. Naismith was opposed to extensive use of the dribble, stating: "The dribble primarily was evolved to enable a cornered player to get away. Yet it is used today as a weapon with which the offensive player can crash into a defensive man without fear of penalty."⁶

Coaching opinions differ with respect to use of the dribble. Some coaches control its use, while others make it their basic offensive weapon. Each coach will undoubtedly be guided by his own ideas of its place in the game.

The dribble was used more extensively in early basketball than today chiefly because the player could practically run with the ball by continuously bouncing it in the air.⁷ It soon became more of an offensive weapon than the

⁶ Ibid.

⁷ "At first there was no limitation as to the number of times that the ball could be batted in the air, and it was not uncommon to see a player running down the floor,

safety measure for which it was originally intended. Its use threatened to break up all team play at one stage of the game and in 1927 was just about to be legislated out of basketball. The organization of the National Association of Basketball Coaches grew out of an announcement by the Joint Basketball Rules Committee, then the governing authority, that it had adopted a change in the rules which virtually eliminated the dribble. The mid-Western coaches called a protest meeting to be held at Des Moines, Iowa, in May 1927. Their protest carried weight and the dribble was saved, for better or worse.

PLAYER MOVEMENT (Cutting): The first real player movement in basketball was the long cut. This was associated with the quick-break and endures today not only in the break, but in set styles of attack.

In the East the short dash, sudden stop, shift, pivot, and change of direction predominate, practically all dependent upon tricky footwork. In the West the quick-break and the long cut, designed to outrun the defensive player, is popular. Accompanying the long cut we find change of pace, speed, and drive.

Styles of play naturally determine the type of cutting which will be most efficient. However, it is doubtful if a squad will be able to master both types. It has been the experience of the writer that players efficient in the use of Eastern footwork could not acquire the drive and long cut technique of the Western player. It is probably true that the Western player would have difficulty mastering the trick footwork popular in the East. The coach will undoubtedly consider the factor of footwork when adapting a style of play to fit the abilities of his squad.

Expert passwork is vital to the success of any attack but without player movement its efficiency is curtailed. Cutting is a planned series of paths which have a definite purpose in the offense.

juggling the ball a few inches above his hand. This so closely approached running with the ball that a rule was inserted saying that the ball must be batted higher than the player's head. At the present time, a clause in the rules states that the ball may be batted in the air only once." (Taken from *Basketball, Its Origin and Development* by James Naismith, Association Press, 1941, p. 65.)

Part II. PRINCIPLES OF THE MAN-TO-MAN AND VARIATION DEFENSES.

CHAPTER III

TEAM PRINCIPLES OF THE MAN-TO-MAN DEFENSE

DURING THE DEVELOPMENT of the game of basketball teams have usually been given one type of defense to cope with all attacks. However, there have been so many offensive changes in the game that defensive players have, of their own accord in most cases, adopted some of the principles of other defenses to meet certain attacks and situations.

In the past decade there has been a revival or development of a number of defenses. When the offense began to mass under the basket, defensive coaches massed their strength there also. When the long shot became effective, defensive players advanced to meet the threat. When give-and-go methods became popular, the defense floated under the basket. For that reason a great number of variations and combinations have developed so that their recognition as a particular defense is almost impossible.

"Stay between your opponent and the basket" is a fundamental rule in the man-to-man defense. However, in scouting it has often been determined that a player dribbles only to the right or that he cuts only to the left and some shifting of floor positions has been advisable.

In a zone defense the player focuses his attention on the ball, oftentimes shifting far away from an opponent in moving to a position in line with the basket. In the man-to-man defense such shifting or floating away from an opponent has also become common.

The attack is often directed toward the defense in an effort to cause confusion or force a collision between defensive players through screening or blocking. The use of the screen-switch, therefore, became important and defensive confusion was avoided by switching on all screening plays, whether inside or outside.

The man-to-man defense can be employed against any offense. In fact, it successfully checks most attacks and is regarded by the majority of coaches as the best defense in the game. However, it requires considerable team play, especially with respect to screening, sliding, and switching. It is particularly effective against a team which depends upon a delayed attack or upon a set formation which must be assembled before attempting to score. When opposed to this type of offense the man-to-man players can retreat, await the approach of the opponents, and then use aggressive guarding tactics to throw the opponents off balance and force the play.

At the close of a game when behind in the score use of the man-to-man

defense is imperative. Practically all teams are now coached to freeze or control the ball in the closing minutes of a game when they are leading by a few points.

The fundamental position rule of the basic man-to-man defense is to stay between the opponent and the basket at all times. However, an exception to the rule is permitted when opposing a pivot player under the goal. At this time the guard may shift left or right and even in front of the opponent to discourage a pass, make an interception, or force him to move away from close proximity to the basket. Defensive players should endeavor to secure a position which will enable them to see their immediate opponents as well as all other competitors, their teammates, and the ball. When a choice is necessary between the opponent and the ball, the man-to-man defensive player concentrates upon the man.

PSYCHOLOGICAL OR MENTAL: The approach by the coach to individual and team defense must be psychological and practical. The psychological approach is concerned with the minds of the players individually and collectively. If defense is to be taught successfully it will be necessary for the coach to inculcate in the player and the team a feeling of pride with respect to their defensive play. The coach should be anxious to develop in each player an attitude of determination to guard opponents so closely that they will be held scoreless.

From the team viewpoint the player should feel that not only must his opponent be held scoreless but that teammates should be assisted whenever possible. Players often overlook the necessity of guarding their respective opponents so closely that they will not be able to make a good pass to a teammate. If the proper attitude is developed each player will be alert, aggressive, and determined to accept the responsibility not only for his immediate opponent but those of his teammates as well.

The game philosophy of the individual will determine to what extent he wishes to concentrate on defensive play. Individual defense comprehends a personalized duel between two players. One or the other will dominate. Aggressiveness by the defensive player often pays dividends because the opponents' passes and shots are hurried.

Anticipation plays an important part in the mental approach to the defensive task. Determining whether the pass will be made or not, when, to whom, and what type it will be, is a part of the intuitional abilities a good defensive player must develop. The application of a team defense depends upon the combining of the various individual abilities of each player. Here again, there is a psychological point of view which will distinguish a strong from a weak defensive team.

A strong defensive team displays mental aggressiveness and confidence in its play. Its quickness in setting up a defensive formation, sureness in movement, ability to slide, screen, switch, and general team work, distinguish it as a team which takes pride in the ability to meet any attack the opponents may attempt.

MATCHING MEN: Man-to-man defense in the strict interpretation of the term implies that each player selects or is matched against an opponent at the start of the game and thereafter tries to keep this opponent from "receiving, passing, or shooting the ball." In the play of the game there are many screen

ing and blocking situations wherein the defensive player may be momentarily separated from his opponent. At the first opportunity, however, he is expected to reassume the guarding of the opponent with whom he was originally matched.

The assigning of men permits the coach to employ his scouting notes to match height with height, speed with speed, and the abilities of a high scoring opponent with those of his best guard. When a coach assigns his best defensive man to cover the opponent's strongest man it is wise not to impress the player that he must stop this particular competitor because he is a good shot, a fine dribbler, or a clever passer. It is better psychology to tell the guard that he is being assigned to oppose the "star" because he himself is faster and smarter.

TALKING: A vital factor to successful team defense is the ability of the players to direct their teammates in avoiding blocks, screens, and sleeper plays. Talking is important from the point of view of morale. A good hustling basketball team is constantly chattering, peppering up the defense, and reminding one another of guarding lapses.

STOPPING THE QUICK-BREAK: Elsewhere in this book methods of stopping the quick-break are described. The team defensive techniques with respect to checking the quick-break should be thoroughly mastered.

DEFENSIVE BALANCE: The importance of defensive balance cannot be over-emphasized in developing a defense. Undoubtedly the offensive circulation will be such that no matter what maneuvers may be required by attacking players defensive balance will be maintained. For example, if an attacking player in the rear court cuts for the basket, the circulation should be such that a teammate will quickly assume his place. There is more danger that this defensive balance will be disturbed when teams are opposing a man-to-man defense than when attacking a zone defense. (It is virtually impossible to score against a man-to-man defense without movement while a number of set formations are effective against a zone.)

A good time to draw attention to the importance of defensive balance is during practice scrimmages. Most offensive teams are chiefly concerned with "putting the ball through the hoop" and forget about defensive preparation. As soon as the offensive team loses possession of the ball the action can be halted and the positions of the players checked.

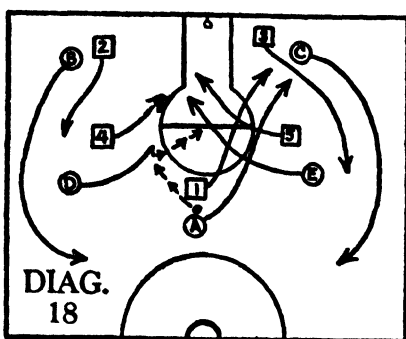
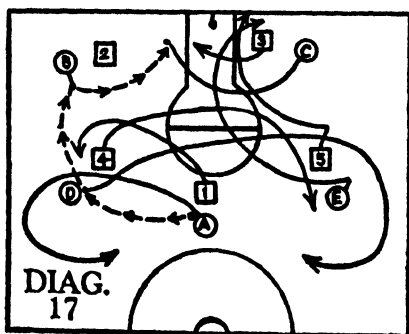

Diagram 17. In this illustration attacking players A and D started the offensive play but reversed as shown to set up the defensive balance. Their

circulation resembles that which is used by rear court players in the flat figure eight.

Diagram 18. Attacking players A and D and E have cut from the rear court toward their basket. This leaves the rear court unguarded unless the front court players, B and C, retreat as shown to set up the defensive balance.

RETREATING METHODS: The man-to-man defense has adopted several retreating methods. The original single line professional style is still used by a great many teams. The five defensive players fall back close to the ten-second line in the defensive half of the court and then maneuver laterally in picking up their opponents. Most attacks against this defense are designed to force crossing of the players so that an attacker may have an opportunity to slip through unguarded. (See Diagram 4.)

The five-man defense formation is also popular. The players drop back in a formation which places three of the defensive players in the front line and their two teammates near or under the basket. This method practically eliminates the matching of men. The first two attacking players who cut through the front line of the defense are picked up by the defensive men stationed near the basket and are thereafter played on a man-to-man basis wherever they go. The remaining opponents are chosen by the three front line players and are also guarded on a man-to-man basis.

Another method may be used in applying the five-man defense. The three players stationed in the front line oppose the first three attackers who approach and follow them wherever they move. The two remaining defensive players usually move forward in order to oppose the two remaining opponents. (See Diagrams 5 and 6.)

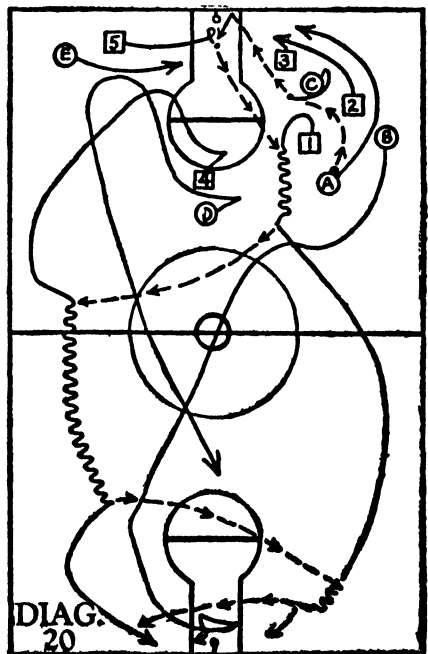
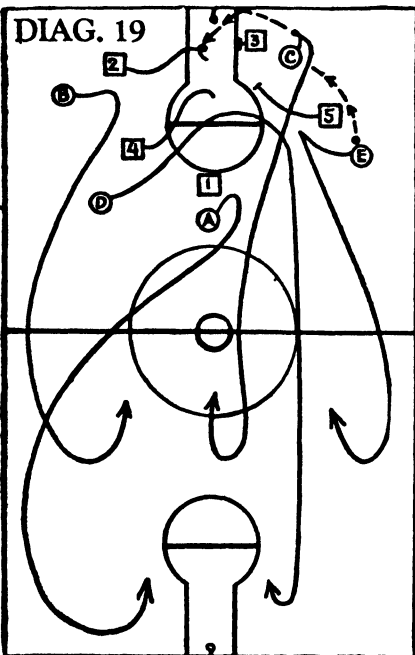

GOOD TRANSPOSITION: Diagram 19. Rear court players A and D retreat under the defensive basket when the ball is lost. Their teammates (B, C, and E) drop back to the front line of the defense. The transposition here is most efficient since each player has moved the shortest possible distance to reach a defensive position.

DEFENSE WHEN OUTNUMBERED: The absence of defensive balance usually results in outnumbering in the dangerous scoring territory under the basket. Two-on-one, three-on-two, four-on-three, and even five-on-four odds may be expected. Players meeting these situations must refrain from committing themselves until they can get help.

OUTNUMBERING (Two-on-One): Diagram 20. The rear court of the offense was left unprotected when D cut toward the basket. Since there was no defensive balance, B started to move into the rear court just as the opponents began a quick-break. Retreating toward his defensive basket B was opposed by opponents 1 and 4. Feinting from one to the other he (B) endeavored to keep 1 and 4 passing the ball from one to the other until he could get help from D.

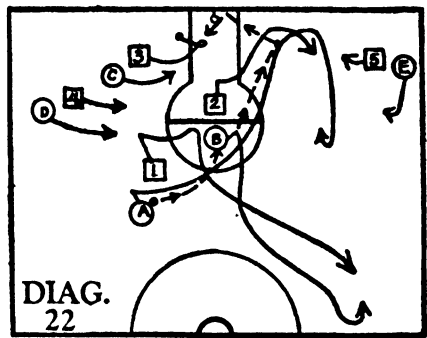
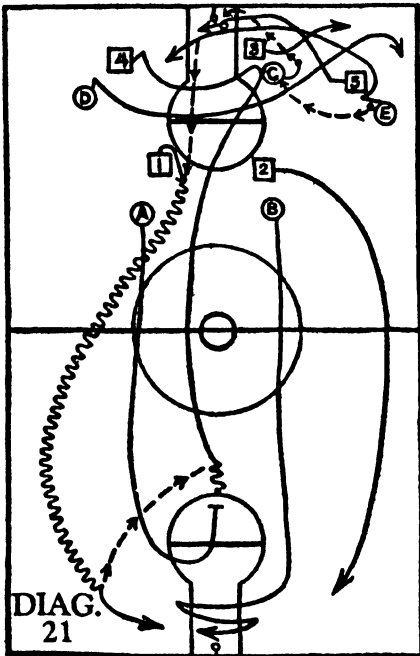

OUTNUMBERED (Three-on-Two): Diagram 21. Although there was defensive balance in the original attack formation, defensive player 4 took a chance that the rebound would be recovered by a teammate and, with 1 and 2, started a quick-break. Players A and B were outnumbered by breaking opponents 1, 2, and 4. They assumed a vertical line in meeting the attack, A taking a position in the free-throw circle and B moving under the basket. A stopped the center man (4) while B attempted to keep 1 and 2 from cutting under the basket for an easy score.

SHIFTING: The shifting of men originated with the professionals in their

use of the five-man one-line defense. Today it is used to designate the trading of opponents by teammates in various situations. It is not to be confused with the switching which may be required because of blocking or screening situations. Whenever an attacking player breaks loose defensive action is necessary. For example, an opponent, while on the defense, may have broken toward his own basket before one of his teammates has secured the ball. This player's competitor may be following the shot, hoping to make the recovery and find himself unopposed when the rebound is secured by the defensive team. In this case an attacking teammate should pick up the loose man and shift his opponent to the teammate who followed the shot.

PICKING-UP: Diagram 22. A passed the ball to B on the post and cut around him for a pass. A switch of opponents occurred between defensive players 1 and 2. However, defensive 1 did not continue to guard B after the ball was passed to A but instead started toward his own basket. Noting the absence of defensive balance in the rear court, B dropped back, picked up opponent 1 and, at the same time, called to his teammate A to pick up competitor 2. This shifting of opponents is necessary to stop the possibilities of either 1 or 2 breaking toward their own basket unopposed.

AGGRESSIVE OR PASSIVE DEFENSE: The basic man-to-man defense may be employed aggressively or passively. When used aggressively it implies that the defensive players will rush their opponents trying to take advantage of any indecision they may have in receiving or passing the ball. The defensive players are willing to take chances in order to rush the play of the opponents, believing that a hurried pass may go astray or that the competitors may be forced away from a good defensive position. (Rushing tactics against a clever ball handling team are dangerous. Fast offensive players like to have an opponent press them closely since blocks, pick-offs, and other plays are then possible.)

When the defense is applied passively it means that the player with the ball, so long as he is not close to the basket, is permitted some latitude in his movements. However, floating is used to such an extent that there is never a clear or open path to the basket. A great many interceptions are possible in this method of defense. Defensive principles imply that the opponents are so strong in their follow-in tactics that an unusual amount of assistance is required under the basket to prevent follow-in and tip-in scores.

FLOOR POSITIONS: The principle of keeping between the opponent and the basket is always observed unless scouting or game information permits the over-shifting in one direction or the other to oppose a dribbler who moves only to the right, a cutter who cuts only in one direction, or a marksman who shoots only from one position on the floor. As the opponent approaches the basket the distance separating the two players is lessened to an extent that some body contact may result in close under-basket play.

Floating is a man-to-man defense weapon which developed from its use in the zone defense. It is employed against a man who does not have the ball. The style of defensive play may permit the use of this weapon in certain situations. (See Diagram 8.)

SCREEN, SLIDE, AND SWITCH: Basic man-to-man defense requires that inside and outside guarding screens be used in keeping up with opponents. Teammates aid this defensive movement by dropping away from their respective



163



164

163. Luisetti popularized the one-hand shot all over the country during his playing days at Stanford University.

164. Good play illustrated. The defensive player (7) is pointing to his opponent, while his teammate has advanced to stop the dribbler. (Note the body balance which the dribbler has used to stop "on a dime.")

Wide World photo.



165



166

165. Ossie Sheckman, Captain of the 1941 L.I.U. team. *H. Fields photo.*
166. Marius Russo, All-American Star of the undefeated L.I.U. team of 1936, switched perfectly on this play. In fact, he succeeded in intercepting the pass made by the post player (Miller of Duquesne). Note the concentration of Russo's teammates upon their respective opponents.

opponents slightly, talking, pointing, and otherwise assisting free defensive movement.

In the matching of men each defensive player is responsible for the passing, dribbling, and scoring abilities of his opponent. This responsibility is avoided only when a block occurs. It is at this point that the team defensive principle must be clearly defined. There should be definite rules with respect to switching. Players use the excuse, "I switched on the play but Bill didn't," "Bill didn't call out 'switch' in time," "I wasn't playing him when he scored," and "Bill switched when he wasn't supposed to." To govern these excuses on the part of defensive players some coaches permit switching only near or under the basket and/or when the ball is passed from one player to another. The switch then permits a teammate to play the dangerous man until such time as the original guard can reassume the responsibility.

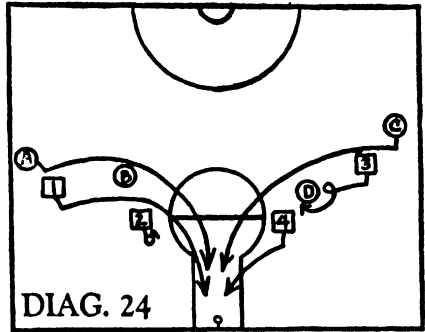
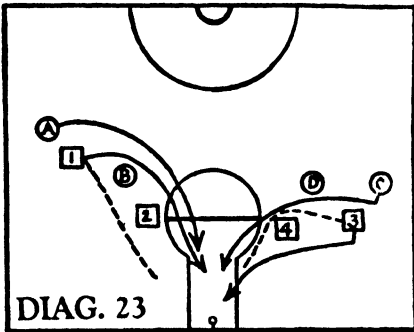

INSIDE AND OUTSIDE SCREENS: Diagram 23. On the left side of the court defensive player 1 is using an outside guarding screen to keep up with opponent A. (The broken line shows an incorrect path which 1 might follow in guarding A. This path should be avoided at all times.)

On the right side of the court defensive player 3 is using an inside guarding screen to keep up with opponent C. (The broken line shows an incorrect path which 3 might follow in guarding C. This path should be avoided at all times.)

SLIDE AND SWITCH: Diagram 24. On the left side of the court defensive player 1 uses a slide to move between opponent B and teammate 2 in keeping up with his individual competitor (A). (Note that defensive player 2 has retreated slightly to leave room for 1 to slide through.)

On the right side of the court defensive player 3 has been forced into a block by attacking player C. Player 4, guarding post opponent D, called switch when he saw a block was about to occur and assumed the guarding responsibility of C. Player 3 used the spin to get into a good guarding position on opponent D. (The spin would not be used by 3 unless contact with D resulted.)

MEETING A DRIBBLING ATTACK: A great many offenses are developed around the use of the dribble as the major attacking weapon. Dribbling teams believe that the defense will consistently foul them in trying to stop shots in the early part of the game. After the opponents have been charged with a number of personal fouls it is the theory that the dribblers may find it pos-

sible to drive in for easy scores because of the likelihood that defensive players will hesitate to guard them closely for fear of being fouled out of the game.

Whether or not the dribbler should be forced toward the center of the court or toward the outside is a matter of coaching opinion and will depend upon the general team principle. Practically all dribblers try to drive around their opponents to the outside (along the side or end lines).

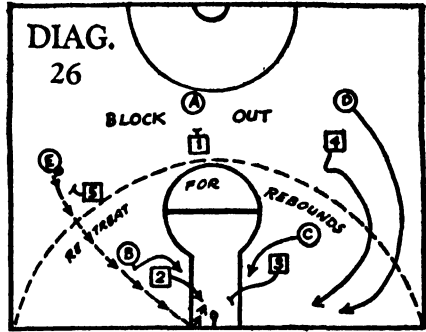
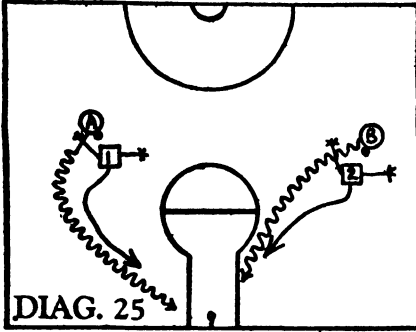

FORCING THE DRIBBLER IN OR OUT: Diagram 25. On the left side of the court attacking player A has dribbled on the outside and toward the basket. The defensive player possibly encouraged this drive toward the side line because he extended his left arm vertically to stop a possible shot. Most dribblers drive toward the outside and if they gain an advantage a score or foul will likely result.

On the right side of the court defensive player 2 discouraged a drive along the side line by extending his right arm laterally. The attacking player was possibly encouraged to attempt a dribble down the center of the court because the left arm of defensive 2 was extended vertically to discourage a shot.

GUARDING AN OPPONENT AFTER A SHOT: When an opponent has attempted a shot and the ball is in the air the defense is still in effect. Although the advantage is with the defense with respect to recovery, guarding players should not feel that this possibility permits them to disregard their respective opponents. Each guard should keep his opponent in view while retreating unless he is in the rebound area, so that his respective competitor cannot cut around him, follow-in the shot, and help to outnumber the defensive players under the basket.

In keeping opponents away from the dangerous under-basket area a shift of position may be necessary by defensive players. Although some coaches recommend that the defensive player pivot and face the basket, it is probably more conservative to continue facing the opponent and retreat somewhat so that he can be opposed no matter what direction he may follow. In blocking the opponent away from the basket the defensive player must be careful not to use the legs, hips, or arms.

Although some defenses zone all their men under the basket when a shot is attempted by the opponents, this is not considered a good policy because deep rebounds or a quick pass out by teammates may permit the receiving player ample time for a set-shot.

GUARDING AFTER A SHOT: Diagram 26. The rebound area is bounded by the

broken line. The space outside of this rebound area represents that in which defensive players are expected to continue to guard their respective opponents. In this illustration attacking player E attempted a shot and defensive players 2 and 3 went in for the rebound. The ball was recovered by guard 2. Defensive players 5 and 1 continued to watch their opponents after the shot even though they (E and A) made no offensive move. Defensive player 4, however, was forced to retreat in guarding his respective opponent (D) who followed-in, hoping that he could join B and C in outnumbering rebound-guards 2 and 3.

REBOUND METHODS: In Chapter II the rebound-triangle was discussed in connection with the position defense. This defensive measure is found in the under-basket defense of most zones and the man-to-man defense uses it when opposed to a strong follow-in attack. Although the individual players who are responsible for under-basket recoveries may possess exceptional rebound abilities, the use of the triangle may be imperative against some teams. However, two defensive players may be so adept at blocking out for one another under the basket that it is not necessary to give them the added protection which the triangle or "Y" affords.

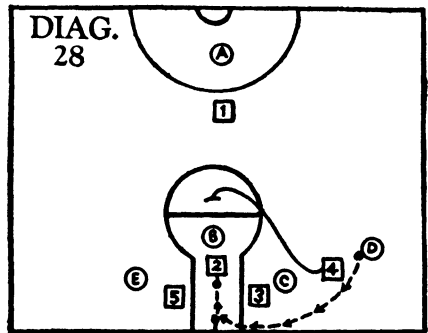
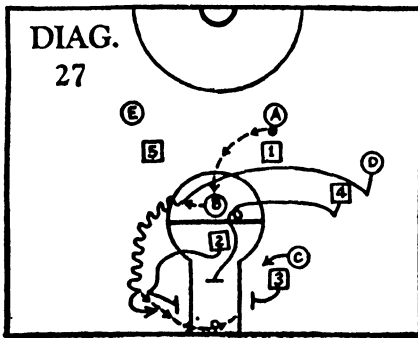

THE REBOUND-TRIANGLE: Diagram 27. Attacking player A passed the ball to B on the post. D feinted to go down the side line, reversed direction, cut in front of the post, received the ball from B, dribbled toward the basket, and attempted a cut shot. Defensive players 2 and 4 switched on the play, 2 opposing the dribbler (D), and 4 spinning to guard B on the post. Immediately after D attempted the shot, 4, 2, and 3 formed the rebound-triangle under the basket. Their teammates, guards 1 and 5, were outside the rebound area and continued to watch their respective opponents.

THE REBOUND "Y": Diagram 28. Attacking player D attempted a shot and the rebound-triangle was formed by defensive players 2, 3 and 5. Defensive player 4 started to move under to help in forming the triangle, but observing that his teammates had the under-basket territory protected, cut to the free-throw line and the rebound "Y" was in formation.

FREEZING THE BALL: Although possession usually means that the team with the ball is on the offense, freezing tactics in reality represent a defensive application. The use of "fishhooks," sudden stops and starts, change of direction, and a post or pivot may be important in maintaining possession of the ball.

When the opponents are ahead in the score and freezing the ball, it is

important that the defense secure possession. If possible it is wise to prevent the start of a freezing attack. Use of the pressing defense is probably the most effective means of meeting the "stall."

After the stalling team has succeeded in crossing the ten-second line, close guarding is absolutely necessary. The use of the screen-switch defense offers a number of advantages here since crossing will not be necessary and the opportunities to watch the ball may afford interception opportunities.

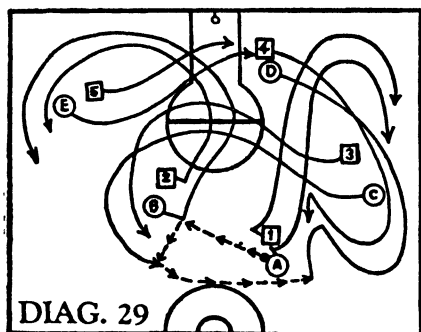

Diagram 29. The stalling method here illustrated comprehends a continuity which requires the players to fill in the starting positions shown. Retreating paths are directed up the sides of the court while cutting toward the basket is down the center.

A passed the ball to B, changed direction, "fishhooked" to the right corner, and moved up the side line. D broke out from under the basket and received the ball from B. C cut across the court and replaced B who had cut toward the basket after passing to D. E replaced D in the continuity. The lateral movement of the ball can be protected by vertical passes when teammates outrun or outmaneuver their opponents. Dribbling may be permitted but it is wise to keep the ball moving, from player to player. Vertical cutting is most efficient since the use of the screen-switch defense may check lateral movement.

PRESSING: The use of pressing tactics is absolutely imperative when a team is behind in the score and the game is nearly over. If the team has been practiced in its use, the weapon may serve to win several games which might otherwise be lost.

SPECIAL DEFENSIVE MEASURES: Although the man-to-man, zone, screen-switch, and pressing defenses should serve to check all attacks, the use of floating or other special methods may be used to meet the exceptional or unusual strengths of certain opponents.

GUARDING THE PIVOT SCORER: Not infrequently a team is met whose chief scoring threat is centered in a strong post or pivot player. Good man-to-man guarding means that the defensive player will move around and about the pivot player to such an extent that he cannot secure the ball if he stations himself in his strong scoring position and waits for passes from his teammates. When the pivot player maneuvers in securing a good scoring position, it may be necessary to block his path, use double-teaming (sandwiching), or zone the territory in which he works. (Floating tactics may help in this zoning.)

A defensive measure which has proved effective in certain instances requires the guard to play in front of the pivot player. Considerable experience is necessary in this guarding because the pivot opponent may use his body to block the defensive player away from rebounds and even passes. It is a dangerous method because it violates the first principle of the man-to-man defense—stay between your opponent and the basket. However, this possible disadvantage may be overcome if the guard is expert in anticipating shots and shot-passes.

It may be necessary to use a combination defense in halting the high scoring pivot opponent. The front line may employ man-to-man principles while the under-basket defense uses zone methods. This procedure may be reversed. The front line of the defense may employ zone principles and the under-basket defenders man-to-man tactics. The use of zone principles by the front line players will permit them to float back to help the under-basket defense when the ball has been advanced. The floaters may be able to discourage or intercept passes and/or intercept the ball.

GUARDING A POST PLAYER: Post players are stationed near the free-throw line. In guarding these opponents there is not so much danger attached to a shot because of the distance from the basket and the possible decrease in accuracy. There have been a number of marksmen who could score from this extended pivot position through the medium of turn or step-away shots, but they were exceptional. The defensive player should be, and usually is, first concerned with the switching possibilities which may be necessary and second with stopping a shot by the post player.

THE GIVE-AND-GO: Against an exceptionally strong give-and-go type of attack a definite rule may be established whereby the defensive player closest to the basket guards the first cutting player. This will avoid the defensive confusion which usually accompanies the use of give-and-go and screening methods. Floating tactics or the use of the screen-switch defense are effective in stopping this attack. (The zone defense is probably the best possible for a give-and-go or hard cutting offense.)

GUARDING AN INDIVIDUAL STAR: Practically all teams have an outstanding scorer who is depended upon for a certain number of points each game. Pointing for this particular player is important since a checking of his scoring ability may disrupt the entire attack of the opponents. Scouting or general information may serve to determine his scoring methods, after which plans can be made to check his efforts. Just as there is usually an exceptional scorer on each team, so too is there a fine guard on most squads who is proud of his defensive or "dogging" ability. A duel between this guard and the high scoring opponent may be interesting and worth while. The advantage in most cases is with the guard. His teammates will give him help and the opponent can not depend upon scouting to determine his weaknesses accurately.

The offensive abilities of the star opponent may be hampered by forcing him to do heavy defensive duty. For example, most coaches assign their star scorer to guard a weak offensive opponent. The weak attacking player can be instructed to cut at every opportunity in an attempt to tire out the star and to force shots when closely guarded under the basket in an effort to draw fouls. A little "jockeying" or ribbing may get the star up in the air

and the defensive player should use this method if the opponent is really "touchy." (The kidding must be carried on in a gentlemanly manner.)

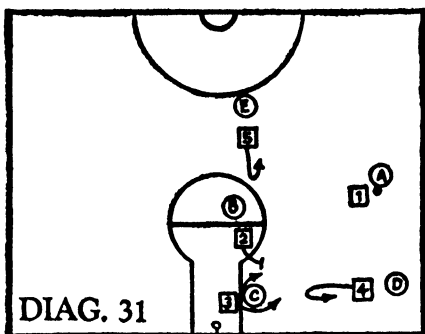
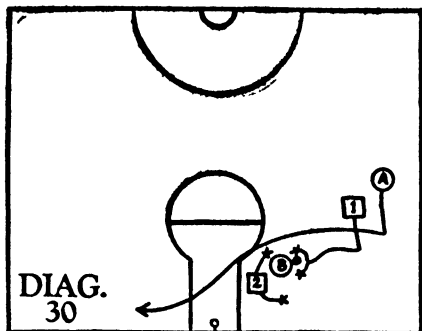

DOUBLE-TEAMING THE PIVOT PLAYER: Diagram 30. The ball is in the possession of the pivot player B. His teammate, A, cuts as shown. Defensive player 2 plays the pivot man closely and discourages a pass to A as he cuts by. Guard 1 is forced near the pivot by the action of A and, instead of switching to the rear of B, plays him from the front in an effort to tie-up the ball.

FLOATING AGAINST THE PIVOT PLAYER: Diagram 31. With the ball in the possession of A, defensive 3's teammates have floated to discourage a pass. Each defensive player is concentrating upon his respective opponent in addition to the ball. Guard 3 can shift to the left or right side of the pivot player, depending upon his (the pivot player's) use of the left and right hand in shooting. The player guarding the post opponent (2) and his teammate (5) have floated vertically. Defensive 4 has backed up toward the basket while the guard playing the opponent with the ball has guarded him closely to hurry or discourage the pass.

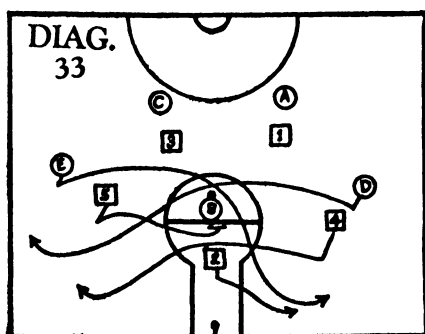
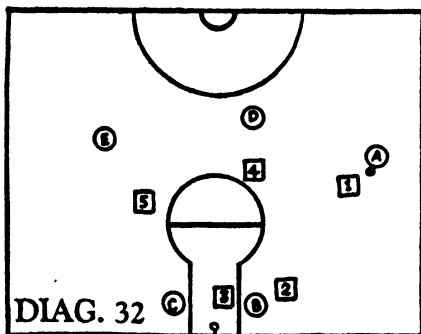

OPPOSING THE DOUBLE PIVOT: Diagram 32. A number of teams with two exceptionally tall and strong pivot scorers utilize their height in an under-basket attack. Rice Institute featured this attack for several years. Two tall pivot scorers, B and C, are stationed on either side of the free-throw lane close to the basket. Their teammates use high over-the-head or one-hand and two-hand shot-passes to these players who attempt a shot and use follow-in tactics to keep tapping the ball until a goal is scored.

In this illustration the ball is in the possession of A who is being opposed by defensive 1. Guard 2 who is matched against B has moved directly in

front of him while his defensive teammate 3, who is assigned the guard C, has taken a position in the lane and between the two pivot scorers. When the ball is passed to the other side of the court the procedure is reversed, 3 moving in front of C while 2 takes the position in the center of the lane. This is an excellent under-basket defense, providing defensive guards 2 and 3 are aggressive and active.

GUARDING THE POST PLAYER: Diagram 33. The post player (B) has the ball in his possession and is waiting for his teammates to cut. His opponent, guard 2, has dropped back toward the basket a slight distance to aid in switching quickly should necessity arise or to provide room for teammates to slide between the post player and himself. He is prepared to stop a shot by B or guard him should he attempt to dribble. Attacking players D and E "split the post" as shown. Defensive 4 followed D and was able to use a slide to guard him. E succeeded in driving defensive 5 into a block at the post but the success of the maneuver was nullified by the switching efficiency of 2 and 5. Two guarded E while 5 had no difficulty in securing a good defensive position on B.

DEFENSE AT THE CENTER JUMP: The tallest men are not always the best jumpers. When one team possesses a height advantage, however, it may be necessary to plan a defensive formation and then make an effort to "steal" the ball. Since the center jump will be used only three or four times during the progress of a game, it is probably unwise to spend too much time in developing a number of defenses. Probably one good defensive center jump formation will be sufficient. It must be kept in mind that the formation which is assumed by the team controlling the tap will, in most cases, determine the positioning of the defensive players.

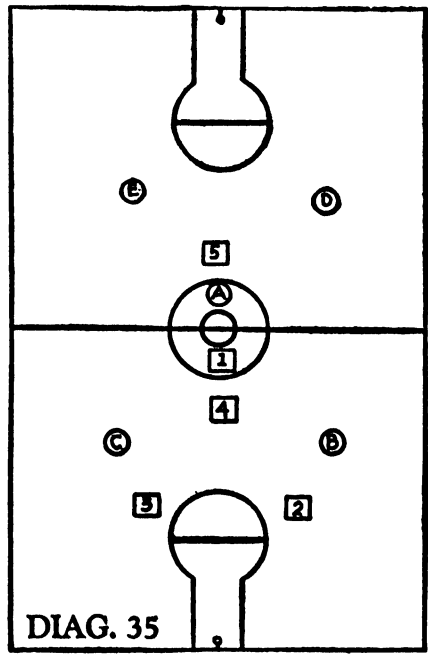
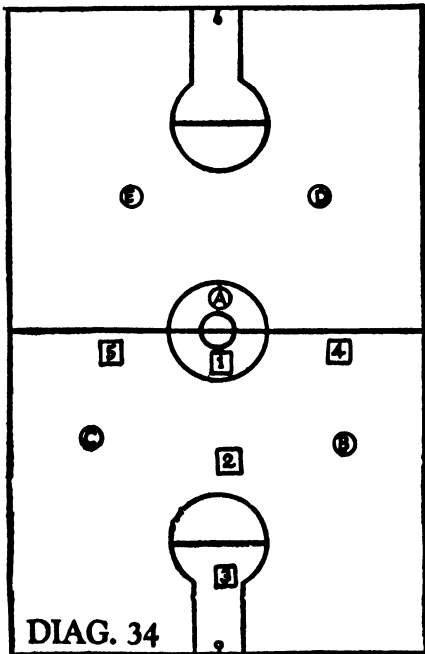

Diagram 34. The defensive "T" formation illustrated here is probably as strong defensively as is possible and yet permit some opportunity for obtaining the ball. The jumper can attempt a deep back-tap. Defensive players 4 and 5 may be permitted to move in any direction in an attempt to steal the ball. Since their opponents, D and E, are in the opposite half of the court, not much danger exists with respect to a scoring play that cannot be checked before it reaches the basket. Players 2 and 3 are in a position to guard their respective opponents and, in addition, player 2 may join up with either 4 or 5 in an attempt to steal a forward tap by A to B or C.

Diagram 35. This defensive formation provides players 4 and 5 with an opportunity to make an interception and yet maintain a good guarding position in opposing their respective opponents D and E. Before the ball is thrown up for the tap, 4 and 5 may exchange signals to designate the direction in which they will move in an attempt to intercept the ball.

DEFENSE FOR HELD-BALL SITUATIONS: It is impossible to develop a formal defensive formation for held-ball situations. The positioning of the defensive players depends almost entirely upon the locations which their opponents (who are presumed to be in control of the tap) may assume. In a zone defense a set formation may be employed. It is also possible to use the substitute jumper method so that the formation will always maintain its set position without the necessity of maneuvering more than two players. However, in the man-to-man defense each player must assume a good guarding position between his respective opponent and the basket. Even when there is some chance that the tap may be secured, it may be wise to use a defensive formation.

Factors which influence the positioning of defensive players are the height and leaping abilities of the jumpers, the score, the time remaining to play, and the size of the court. When a player is jumping against an opponent other than the one to whom he is assigned, it is vital that he instruct the free teammate to shift to the unguarded competitor. Both players should check this shifting of opponents so that there will be no confusion following the jump.

Floating principles are important in defensive held-ball situations. Defensive players who are opposing competitors on the opposite side of the court may float toward the under-basket territory. Since every attacking team will set up its own defensive balance (between the ball and the defensive basket), players guarding the rear court opponents may float vertically toward their basket.

DEFENSIVE POSITIONS FOR BACK COURT HELD-BALL FORMATIONS: Diagram 36. Defensive player 1 is jumping against his respective opponent (A) who is presumed to be tall enough to control the tap. Defensive players 2 and 4 have floated vertically while teammate 5 has moved laterally toward the basket. All of these floating players have maintained a position between their opponent and the basket and are concentrating first upon their respective opponents and second upon the ball. Guard 3 is opposing C but has retreated a step or two so that he will be prepared to pick up an opponent who may break free. (Note that 2 can take a chance on breaking toward his basket because of the under-basket positions of 1, 3, 4, and 5. In case one of

his teammates secures the ball he might possibly break quickly enough to secure an easy basket.)

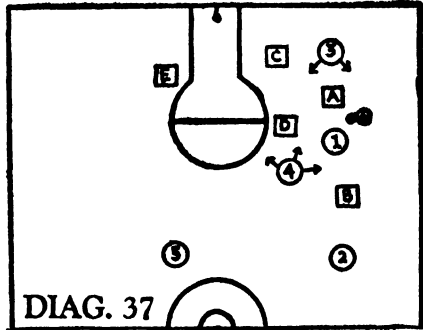
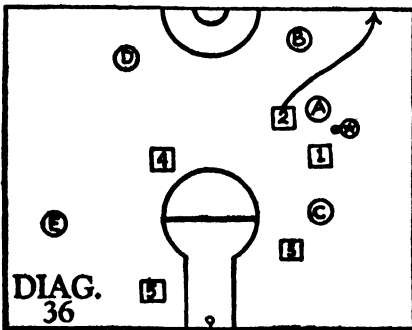

DEFENSIVE POSITIONS FOR HELD-BALL SITUATIONS IN THE FRONT COURT: Diagram 37. Player 1 is jumping against opponent A. Defensive teammates 2, 4, and 5 have arranged themselves in positions so that they will be able to retreat quickly to the back court. Player 3 has taken an offensive position but undoubtedly will break back toward the defensive basket when the ball is tapped. Because of the safety positions of 2 and 5, their teammates 3 and 4 may attempt interceptions. In case opposing players A, B, and D break toward their basket, 3 and 4 can be shifted to C and E while 1, 2, and 5 guard the breakers. (Players 2 and 5 would be expected to quarterback this shift of opponents.)

DEFENSE FOR OUT-OF-BOUNDS PLAYS: There are two defensive theories with respect to opposing out-of-bounds plays. In one the defense opposes the out-of-bounds player and his teammates aggressively. The player guarding the man with the ball out-of-bounds stands directly in front of him and by waving his arms, shouting, and kicking his feet, tries to prevent a good pass. His defensive teammates play close to their opponents and endeavor to force them to retreat to secure the ball. The alternate theory is more or less passive in its application. The man with the ball out-of-bounds is not opposed directly. The player guarding him retreats toward the basket so that the ball and his individual opponent's teammates may be watched simultaneously. The other defensive players use floating principles to retreat toward the basket so that a blocking or cutting play will be practically impossible. The chief idea here is to allow the ball to be passed into the court to an opponent situated in the back or in his own half of the court.

Practically all out-of-bounds plays directed against the man-to-man defense utilize some form of blocking or screening in their execution. Undoubtedly the most successful are those made from under the basket although side line plays are popular. Perhaps the best procedure is for the defensive players to mass between the ball and the goal and, as soon as the ball is put in play, move forward to oppose their respective opponents.

DEFENSE FOR SIDE LINES OUT-OF-BOUNDS PLAY: Diagram 38. Attacking player A has the ball out-of-bounds on the left side of the court. He is opposed by defensive player 1 who has dropped back somewhat so that he may watch the ball as well as his opponent's teammates. Opponent B has moved to a blocking position behind defensive 1 so that a block play may be attempted.

Defensive players 4 and 5 have floated back and toward the basket so that they may congest the scoring area. Defensive player 3 has also retreated vertically so that he may assist in the under-basket defense. Whether or not guard 1 is blocked by opponent B, the defensive positions of his teammates are such that a scoring play directed under the basket would have little chance for success. Each defensive player is concentrating upon his own opponent and will guard him as soon as the ball is passed into the field of play.

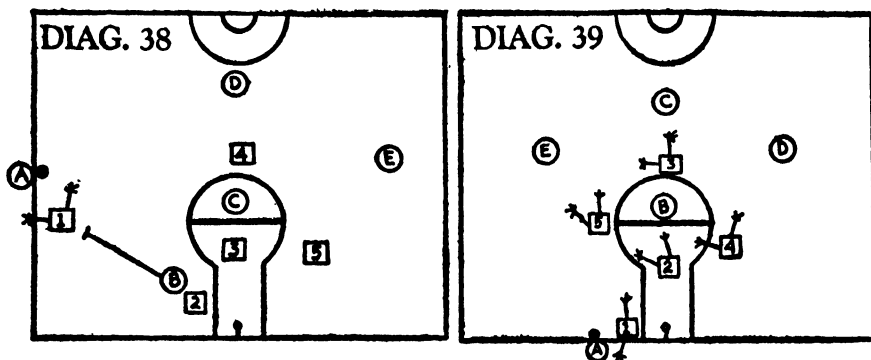

DEFENSIVE FORMATION FOR OUT-OF-BOUNDS PLAY UNDER THE BASKET: Diagram 39. Attacking player A has the ball out-of-bounds under the basket and is opposed by defensive 1, who has moved back toward the goal so that he may watch his opponent, his opponent's teammates, and the ball. The attack formation is a common one and is designed to "split the post." Attacking player B will usually face the basket and the ball may be passed to him if defensive 2 does not guard him closely. In this out-of-bounds defense, it is important that players keep their hands up to discourage passes close to the basket. Undoubtedly defensive players 4 and 5 will be called upon to switch opponents when E and D attempt to cut around B. However, the floating tactics should eliminate the possibilities of a close under-basket shot.

FREE-THROW DEFENSE: When setting up a defense under the opponents' basket, good guarding is required to eliminate the follow-in attack as well as tip-in shots. Free-throw rebounds seldom extend far from the basket since most shots are tossed with little force. The opponent attempting the free-throw must be blocked out from the free-throw lane and the competitor who is located next to the basket must be carefully watched.

Most unsuccessful free-throws fall on the right side of the basket and the opponents situated on that side must be especially watched. When attempting a free-throw it is customary for two men to be placed in the rear court for defensive balance. The chief offensive threat here is that an unsuccessful shot may be secured by an opponent who, through the medium of a long pass, may start a quick-break attack. This is usually possible when an exceptionally tall competitor is stationed close to the basket. There are several methods of counteracting this free-throw danger. (See Diagrams 40 and 41.)

FREE-THROW DEFENSE UNDER OWN BASKET: Diagram 40. Attacking player A is attempting a free-throw and is being guarded by player 3. If opponent 2 is exceptionally tall it may be wise not to try to press him under the basket but make plans to check the first quick-break pass receivers. In case a quick-

break is attempted, players D and E will oppose 4 and 5 while B and C will shift to the remaining opponents.

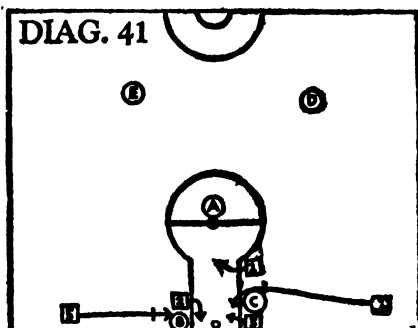
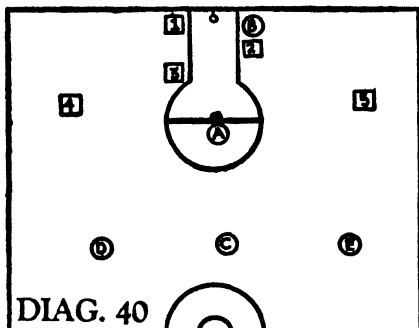

FREE-THROW DEFENSE UNDER OPPONENT'S BASKET: Diagram 41. Since players D and E have retreated to the rear court, opponents 4 and 5 may take positions in the corners where the ball will be passed to them following the free-throw. However, if opponents B and C are exceptionally tall and use follow-in tactics after a free-throw, it may be necessary to move 4 and 5 to the sides of the free-throw lane where they can assist in guarding these players.

In the illustration defensive player 1 will block the free-throw opponent as soon as the ball hits the backboard or the rim. In guarding this player 1 will face partly away from the basket so he can watch the ball as well as his opponent. It is absolutely vital that opponent A be blocked out of the free-throw lane. On the left side of the basket opponent B has the inside position and is particularly dangerous. Defensive players 2 and 5 may team up in their efforts to block him away from the basket. Player 2 will move into the lane in front of B if possible, while 5 will maneuver to the outside as shown. On the other side of the lane defensive players 3 and 4 should have less difficulty in "sandwiching" opponent C. This is probably the strongest free-throw defense possible.

CHAPTER IV

DEFENSES FOR THE QUICK-BREAK

IN PLANNING ways and means to stop the quick-break something should be known about the defense employed by opponents. If they use a man-to-man defense their quick-break methods will differ from those employed by a zone team. Irrespective of the type of defense, aggressive or passive principles may be employed in its application. Against a team which is more concerned with defense than offense, little planning is necessary.

Most quick-breaks can be slowed down providing certain principles are observed. Opinions differ with respect to the "pick-up" of men as soon as they get the ball, retreating under the basket to stop the short shot, or methods of playing a dribbler.

When opposing a man-to-man defense the positions of the attacking players usually govern the defensive alignment. Since players are matched the defensive guards are more or less required to follow their attacking opponents wherever they move. Because of this fact it is undoubtedly easier to check a quick-break from the man-to-man defense than from a zone.

Zone defense players oppose the ball rather than the man and do not find it necessary to follow a particular opponent. They are, therefore, in position to break quickly for their basket when the ball is recovered from the back-board, not infrequently unopposed by defensive players. This usually occurs because the attack has not set up its defensive balance while maneuvering for a good scoring position.

The success of the quick-break from the man-to-man defense depends chiefly upon the ability of the defensive players to move toward their basket unopposed chiefly because attacking players in cutting for a score are usually out of position following a shot or an interception.

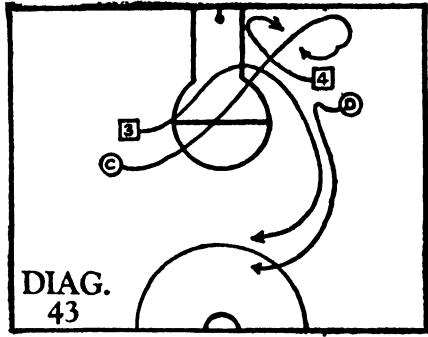
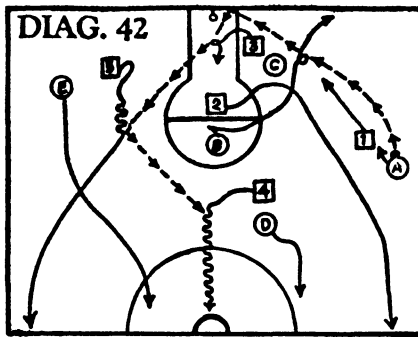

ATTACKING PLAYER OUT OF POSITION: Diagram 42. Attack player B cut for the basket and succeeded in gaining a step advantage on his opponent (2). Cutting hard, B received the ball from A and attempted a lay-up shot. His momentum carried him off the court. Guard 2 had followed B to the basket but could not stop the shot and, noticing that his teammate 3 was in position to recover the ball, reversed direction and cut toward his own basket. Guard 3 passed to his teammate 5 on the side of the court and a quick-break resulted. Even though E dropped back to assist D in the rear court defense, they were outnumbered by opponents 2, 4, and 5 chiefly because the player who attempted the shot (B) was out of position. (A should have recognized the possibilities of this situation and shifted opponents with B. A could have picked up 2 and called to B to guard opponent 1 who had gone in for the rebound.)

DEFENSIVE BALANCE WHILE ON THE OFFENSE: The offensive quarterback is responsible for the defensive balance of the team. The quick-break will be checked only if he is given support by teammates. Defensive balance means the rear court will be protected at all times. Such protection usually requires the presence of two men. The quarterback must secure aid from teammates when left alone. He can do this by shifting a teammate to the rear court to take the place of a player who cuts.

SHIFTING OPPONENTS: An attacking player should sense the defensive position of the player opposing him. Even when cutting under the basket and

after having outmaneuvered his respective defensive man, the cutting player should know the location of his particular opponent. When a cutting player attempts a shot close to the basket, his immediate opponent will usually go in for the rebound. This affords the attacking player an opportunity to regain defensive balance on his particular guard. If the guard does not go in for the rebound but reverses direction and cuts toward his basket, a trading of opponents between the shooter and a teammate is necessary. Most teams using the man-to-man defense call this the "pick-up" and the player who is closest to the defensive basket will say, "I have your man, number 3; you take 4." This trade of opponents will usually take care of the situation.

THE PICK-UP: Diagram 43. Attacking player C cut for the basket. Guard 3 followed him nearly to the basket, then reversed direction, and started for his own goal. Noticing that his teammate C was out of position, D called to C, "I have your man, number 3; you take 4." (The shift was possible because defensive 4, D's opponent, had retreated toward the basket for the rebound.)

FIRE AND FALL BACK: Defensive teams which attack a zone defense with a strong quick-break sometimes limit their offense to "fire and retreat" methods. Each attacking player is given a specific defense duty and the success of the method demands each player carry out his assignment. Certain players are to follow-in while others (rear court marksmen) check the key quick-break cutters and scorers. The best marksmen attempt the shots. If the opponents do not have a strong delayed attack, the method may be effective.

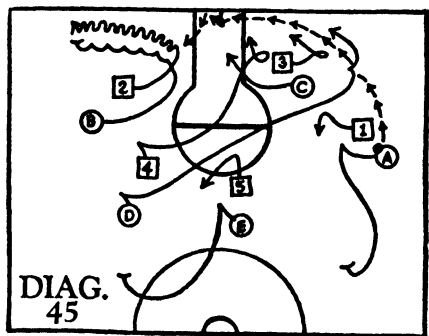
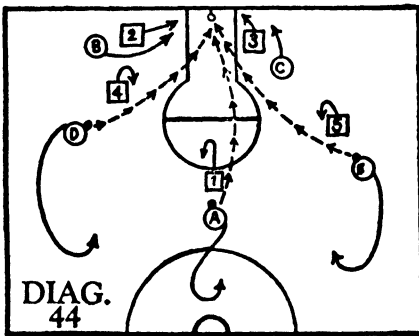

Diagram 44. Attacking players A, D, and E are in the best set-shot positions and "fire away" regardless of the defense used. Following a shot, these three players (A, D, and E) fall back to check the quick-break by the opponents. Their teammates, B and C, follow-in all shots, attempting to secure the ball or slow down the first pass.

MANEUVER KEY MEN OUT OF POSITION: In the man-to-man defense the players are usually matched at the start of the game. If it has been possible to scout the opponents, players will undoubtedly be matched because of size or speed. In this connection it is important that the speedy attacking players operate from their rear offensive court where they can meet the fast quick-break cutters.

Since the quick-break must start from the rebound or after a score, it may be possible to draw the usual rebound-guards away from the basket

The attacking player may work out from the under-basket territory to the ball, thus forcing the guard to follow. This will be especially effective if the pivot player possesses a good short shot and is not afraid to use it.

The first pass receivers can also be maneuvered out of position if the rear court attacking players opposed to these men will follow-in or drive toward the corners. The attackers must be careful that the receivers do not out-smart them and break to the offense instead of continuing on the defense.

CHECKING AT THE SOURCE: This can be accomplished by following all shots and trying for rebounds. If the ball is not regained the follow-up should be directed toward rebound-guards so the first quick-break pass will be delayed. Forcing a dribble to the corner is sufficient. If a held-ball can be secured, all the better. Players must be impressed with the fact that a quick-break develops and ends within the space of a very few seconds. Checking the quick-break is a success if it provides sufficient time for teammates to reach their defensive positions.

The follow-in principle should not be pursued to such an extent that it becomes a pressing defense. If the first pass has been delayed, sufficient time has elapsed; further pressing may result in an outnumbering advantage for opponents. Follow-in tactics often disturb the rebound-guards to such an extent that they forget about the quick-break in their efforts to protect the ball. The number of follow-in players will depend upon the attack formation, the number of defensive rebound-guards, and the retreating method which is in effect.

The shifting of opponents which was previously discussed is absolutely necessary when the attacking pivot man or one or more teammates is assigned the duty of following-in teammates' shot attempts. While following-in these shots, a player may find himself opposed to an opponent other than the one with whom he has been matched. In this case his first duty is to slow down the first pass and then guard the passer, while the teammate who originally opposed this under-basket player picks up the odd opponent. In this trading of men the rear court player assumes the responsibility. He calls out the signal to "switch." It is important that he call this play quickly so that the teammate who is pressing the rebound-guard will know just whom to oppose. Frequently a double switch is required. A rear court player may pick up the opposing pivot scorer; a teammate may choose another opponent, leaving the follow-in man to guard a third player. Considerable practice is required before this trading of opponents necessary in stopping the quick-break becomes effective.

FOLLOWING-IN: Diagram 45. A passed the ball to D, who had cut in front of C. A switch was made on the play by defensive players 3 and 4. D attempted a shot and the rebound was secured by defensive player 2. Attacking player B followed-in the shot and, although he could not recover the ball, forced his guard (2) to dribble to the corner. The time required for the dribble to the corner enabled the attacking team to set up its defensive balance and check the possibilities of a quick-break.

STOP THE FIRST PASS: The first quick-break pass may be a long spot or lead pass up the middle of the court, a short or long pass to the side of the court, or a short toss in the vicinity of the free-throw circle. Many quick-breaks from the man-to-man defense designate a particular player to receive

the first pass and this opponent can be played closely immediately after a scoring attempt.

Frequently the under-basket follow-in method does not stop the first pass. (Sometimes a rebound-guard will be exceptionally tall and it is difficult to stop him from passing the ball to a teammate after a rebound.) The exceptionally tall man is invariably coached to keep the ball high above the head, to pass it with a hook or two-hand overhead throw, and his height advantage may be so great that it is impossible to stop such a pass. It therefore becomes important that the receiving point for the first pass be blocked.

COVERING RECEIVERS: A number of teams designate a particular player to receive the first pass near the free-throw circle. Others give rebound-guards an option by planning this first pass to chasers on the side of the court. Scouting will determine what players are most depended upon and defensive plans can then be made to cover these men. Rear court attackers are best situated to cover the receivers and this maneuver may discourage and delay the first pass.

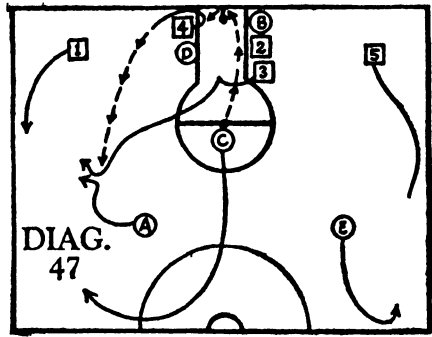
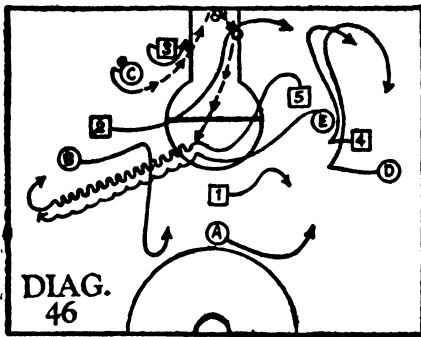

COVERING THE USUAL RECEIVER: Diagram 46. Pivot scorer C attempted a step-away shot on the left side of the basket. Defensive player 2 recovered the rebound and looked for the usual first pass receiver (5) in the vicinity of the free-throw line. The pass was made to 5 all right, but he was so closely guarded by E that he was forced to dribble across the court and finally pivot in order to protect the ball. This guarding of the usual or the first pass receiver often provides sufficient time for the defense to form.

STOPPING THE RECEIVER AFTER A MISSED FREE-THROW: Diagram 47. The recovery was made by defensive player 4, who turned to pass either to 1 or 3. In this case he passed to 3. The method used to stop the quick-break in this illustration comprehends the immediate coverage of the opponent who receives the first pass by A or E, depending upon which side of the floor the ball is thrown. The teammate attempting the free-throw retreats toward the middle of the court and covers the opponent who is free. In this illustration C guarded 1 while E opposed 5.

BLOCKING AND RECEIVING POINTS: If a team has been scouted, the first pass receiving points will have been determined and can be guarded. If the team has not been scouted, it will be apparent after a few minutes of play just what quick-break methods are used by opponents and the receiving points can be readily determined. If, however, no definite receiving points are used,

it will be necessary to concentrate upon the player or players who usually receive these first passes.

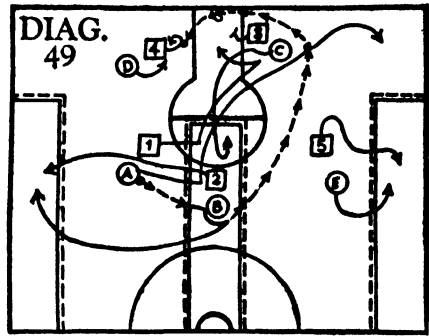
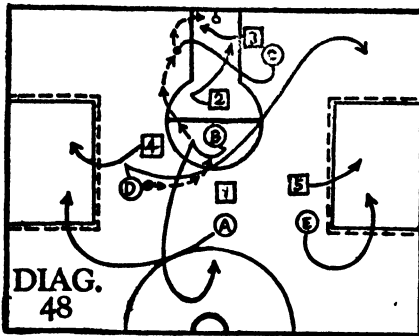

Diagram 48. In this illustration it has been assumed that the spaces on each side of the court bounded by the broken lines are the receiving points or areas to which the first pass of the quick-break is directed. D passed the ball to B on the post and cut as shown. After faking to return the ball to D, B passed to C in a pivot position under the basket. Immediately after the shot and when it was apparent that the opponents would recover the ball, A and E moved into the receiving areas in order to discourage the first quick-break pass. The post player, B, retreated up the middle of the court to protect the center area.

BLOCK THE QUICK-BREAK LANES: Because of habit and long practice, quick-break players usually follow regular paths in developing a quick-break. Certain attacking players can be assigned to these lanes and required to block them. Their presence in the quick-break lanes will cause a delay of the first pass or force the cutters to take longer and new paths which may disrupt the regular procedure of the opponents.

BLOCKING THE LANES: Diagram 49. It is assumed the three lanes bounded by the broken lines are the usual paths used by the opponents in their quick-break. A passed the ball to B and cut as shown. He received a return pass near the basket and attempted a cut-shot. Defensive players 1, 3, and 4 used the triangle to block out under the basket and the ball was recovered by 4. The quick-break cutters 2 and 5 moved toward the usual cutting lanes but their opponents B and E had already occupied these paths. The pivot player (C) covered the center cutting lane when it was impossible for him to follow-in and recover the ball. (Players B and E would, of course, be guided in their movements by the directions their opponents, 2 and 5, took following the shot.) The defense is still man-to-man although every effort is made to block the lanes in the hopes that the presence of a player there may discourage the first quick-break pass.

ZONE THE BACK COURT: There is a difference of opinion among coaches concerning the methods to be used after the quick-break has passed the center of the court. It is probably just as well to check the opponents as quickly as possible. However, retreating under the basket and distributing players in the scoring zones may be as effective. At any rate, the zoning will cause a little delay and may suffice until the defense is assembled and individual opponents can be picked up.



167



168

167. The rebound guard on the inside is about to lose the ball because he did not use the eagle spread. He should have maneuvered his body between the ball and the opponent.

168. It is unwise to hold the ball against the zone defense as the surrounded player is about to learn. He is encircled by four defensive players.



169. Height is important under the basket and Arthur Hillhouse, 6' 6" L.I.U. center, is about to score although surrounded by three Southern California players. 170. Warner Keaney of Rhode Island State "overpressed" in attempting to steal the ball from his opponent and shook the Garden when his 270 pounds nose-dived.

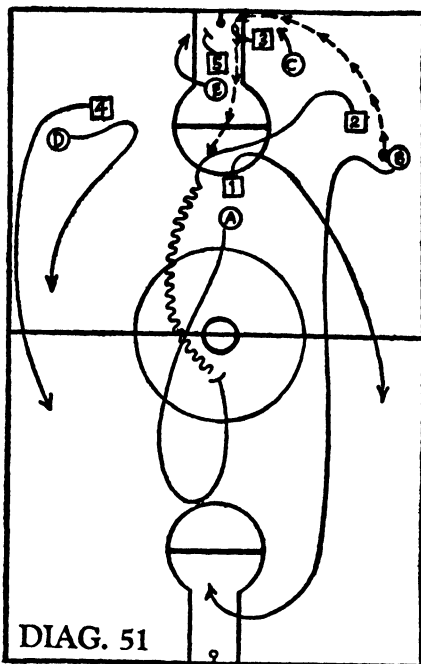
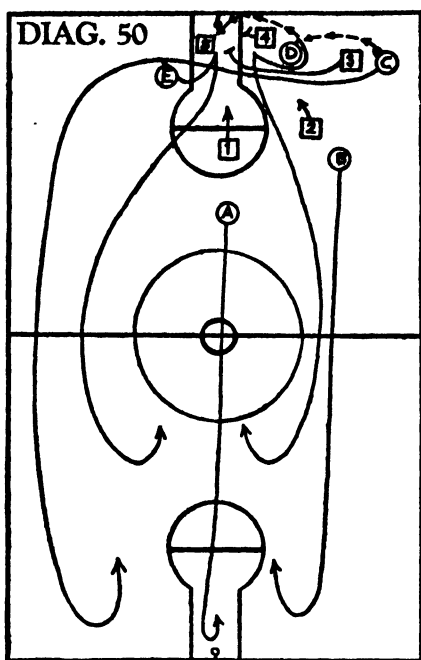

Diagram 50. After maneuvering in the front court C passed the ball to D on the pivot. D faked a return pass and then attempted a turn-shot. Defensive players 3, 4, and 5 formed a triangle under the basket and 5 recovered the ball. Players A and B retreated immediately to the back court where they, in company with C, assumed positions near the basket at the dangerous scoring points. Their teammates, D and E, retreated as quickly as possible and stopped in the front line of the defense so they could guard against long shots. As soon as possible the defensive players would shift to their respective opponents. This retreating method is usually necessary when tall players serve as pivot scorers on the offense and as rebound-guards on the defense. (The distance is too great for them to carry on the work under both baskets.)

STOPPING THE DRIBBLER: When the ball has reached the hands of a dribbler who is coming down the floor to attack, several important decisions must be made. If the rear court quarterback is caught alone he may feel it is wiser to retreat close to his basket before attempting to stop the dribbler. If defensive balance has been maintained there will usually be a teammate in the rear court who can drop back under the basket and the quarterback can attempt to check the dribbler. Such checking means the dribbler will be forced to stop, pivot to protect the ball, and then pass to a teammate. In most cases the stop and pivot requires sufficient time to allow the defense to assemble. If not, the defensive players should immediately drive under their basket and use zone tactics until help can arrive.

Some rear court players are so clever that they can effectively check a dribbler before he gets started. Defensive balance is imperative when this procedure is followed. If the opposition depends upon the rebound-guard to

bring the ball up the floor, he may be checked by an aggressive follow-in. If the guard succeeds in breaking out with the ball, he should be stopped immediately by a rear court teammate. Every dribbler should be met before he can get into stride. The purpose is not to steal the ball but to force a pivot or pass. He must be met with the body low, the arms widely extended, and with feints designed to make him protect the ball. A slight delay is all that is required in this defensive move.

Diagram 51. Attacking player B attempted a set-shot from the side of the court and the rebound was taken by defensive 3. He turned immediately and passed to his teammate 2 near the free-throw line. The offensive quarterback (A) had retreated with the shot to keep an eye on his respective opponent 1. Following the shot, B retreated to help A with the defense. A realized a three-on-two situation was developing and decided to stop the dribbler. He advanced and met him near the ten-second line while B retreated to a position in the free-throw lane where he could maneuver and try to keep 1 and 4 from driving under the basket for an easy and almost sure score.

A method which is more conservative would require A and B to drop back in front of their basket in a vertical line. A would be directly in front of the basket while B would take a position near the free-throw circle. By maneuvering they could possibly delay the scoring efforts of 1, 2, and 4 until help arrived.

MASS UNDER THE BASKET: While teammates are trying to follow the ball, stop the first pass, check the receivers, or meet the dribbler, the remaining players should mass under the basket. Footwork and feinting may hold opponents at bay until help arrives if the checking measures have been unsuccessful.

OUTNUMBERED TECHNIQUE: When none of the planned methods has served to stop the quick-break, the player or players who are stationed under the basket will usually be outnumbered. In this situation it is vital that they "hold the fort" until help arrives. As teammates retreat down the court to assist them, they quarterback the defense by pointing out the opponents to be played. Gradually all opposing players will be covered and the man-to-man matching of men reassumed.

USE THE PRESSING DEFENSE: The pressing defense may be applied to slow down a dangerous quick-break attack. Unless pressing tactics are thorough, it is unwise to make the attempt. Quick-break players often prove most efficient against a forcing defense.

SLOW UP THE GAME: As a last resort, it may be necessary to slow up the game in order to cope with the lightning speed of the opponents. Spectators will, no doubt, "tear down the baskets" but a victory is the chief objective and fans soon forget. This slowing up may be achieved by advancing slowly to the front court, setting up the offensive formation deliberately, maneuvering and protecting the ball by hard forward cuts, followed by a quick retreat, and by refusing to take a shot until absolutely unguarded. It is well to remember that opponents may counter against delay measures by using the pressing defense all over the court to force a speeded-up game.

CHAPTER V

VARIATIONS OF THE MAN-TO-MAN DEFENSE

THE MAN-TO-MAN defense is subject to a number of variations. Most of these have developed because of zone influences such as floating, playing the ball for interceptions, and massing in front of the basket. Two of the most popular variations employ floating and switching tactics. The third adopts no new technique but applies man-to-man principles aggressively all over the court and modern usage has caused it to be regarded as a variation of the usual man-to-man defense.

THE SCREEN-SWITCH: The screen-switch defense developed because of the screening and blocking tactics which came into use following the massing of the defense in front of the basket. George Keogan, coach of basketball at Notre Dame University, popularized this defense in the Middle West and East.

The strength of the screen-switch defense lies in its ability to switch opponents whenever a block or a screen is encountered. Because of this switching, defensive players are usually in a better position to take advantage of the quick-break when an interception occurs than they would be if using the man-to-man defense.

The screen-switch defense is difficult to teach since there is no assigned opponent responsibility. The spirit of teamwork which must accompany the switch of opponents so that the responsibility can be assumed by a player in more dangerous scoring territory is vital to success. Because of the exchange of opponents, floating principles are more easily used than in any other defense with the exception of the zone. Effective use of the screen-switch requires considerable talking and a rigid definition of switching situations. Tall rebound players can be stationed in the rear line of the defense. Because of the frequency of opponent shifting these players can maintain their under-basket positions consistently.

Screening and blocking attacks are directed toward the man-to-man defense and designed to cause defensive confusion. Forcing the defensive players to cross in front or behind one another or running them into post or pivot blocks is the chief purpose of screening and blocking attacks. The screen-switch defense successfully copes with such tactics since a shift of opponents is always made by defensive players whenever a screen occurs. The defense is most successfully used against a team which screens laterally in the back court. The defensive players need not follow these opponents and, in effect, are more or less standing still while their opponents run in circles. The use of floating is possible in the screen-switch defense. The defensive players often drop back as far as the free-throw circle where they more or less enjoy spectator privileges in watching their opponents run from side to side.

The screen-switch is undoubtedly a compromise between the zone and the man-to-man defenses. It attempts to mass its players zone-fashion in front of the basket and also uses the individual guarding principles of the man-to-man defense. A number of advantages are as follows: first, the shifting of

opponents when screening occurs saves considerable footwork as well as energy. Second, like the zone defense, it adapts itself readily to quick-break principles. Third, man-to-man defensive responsibilities are present whenever an opponent is being played individually. Fourth, when behind in the score near the end of the game, the screen-switch can be used similarly to the pressing defense. Actually, the defense uses a great many man-to-man principles in addition to the ability of the defensive players to switch against screening plays.

The disadvantages of the screen-switch defense are comparable to those of the zone. It does not permit the matching of players, requires a tremendous amount of applied coaching and practice, and is not too successful against an attack which uses change of direction and "down-the-middle" plays.

A variation of the screen-switch defense is popular with some coaches. The players in the front line of the defense use man-to-man principles to guard their respective opponents while the under-basket defenders use the screen-switch every time there is a screen or block play. This requires the use of slides and outside screens on the part of the front line of defense which may prove sufficient to oppose competitors unless they happen to be good distance marksmen. The use of the outside defensive screen and the slide takes too much time to stop a good distance shooting opponent.

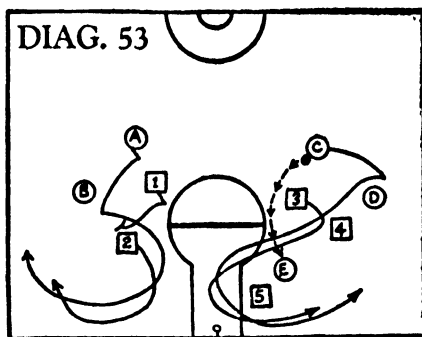
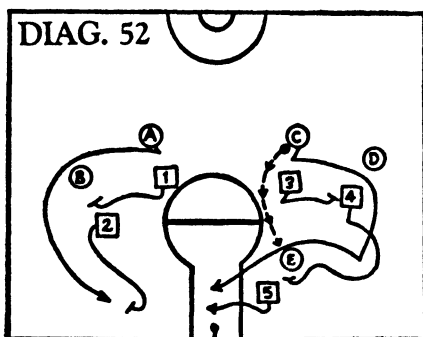

SWITCHING ON SCREENS: Diagram 52. Attacking player C passed the ball to E in a pivot position. On the left side of the court defensive player 1 followed A until he screened behind B. Since the attacking players crossed, a shift of opponents between 1 and 2 was necessary. Guard 2 picked up A and 1 opposed B.

On the right side of the court C screened between D and 4 and a switch resulted. Defensive player 3 opposed D and 4 assumed the guarding of C. However, another switch was required by 4 when C screened in front of the pivot player. Rebound-guard 5 shifted to C and 4 opposed E.

PLAY AGAINST FAKE SCREENS: Diagram 53. On the left side of the court attacking player A moved toward his teammate B as though his intention was to screen in front of defensive 2. Just as A arrived in front of 2 he reversed direction and cut toward the basket. A shift of opponents between 1 and 2 was not necessary because the screen had not been finished.

On the right side of the court attacking player C started an outside screen in back of his teammate but changed direction and cut toward the basket.

No shift of opponents was required in this play because there had been no screen. After changing direction, C cut close to the pivot player E. Here again no switch was necessary because there was plenty of room for 4 to follow C and, in addition, neither of the defensive players (3 and 5) had been screened. However, if a block of 3 by opponent E seemed imminent, a switch might have been called by guard 5.

THE PRESSING DEFENSE: It is the opinion of the writer that the pressing defense should be regarded offensively as well as defensively. It resembles the type of play which accompanied early basketball. Defensive players picked up their opponents just as soon as the ball was lost no matter where they (the opponents) happened to be on the court.

An article written by Dr. Walter E. Meanwell in 1927 brought out the advantages of the pressing defense: "The greatest change, however, with respect to play of the ball in the backfield is in the type of defense which is best employed in the new game. I find that the new style of game renders comparatively inefficient the two-line, five-man defense, stretching across the center of the floor. *We find it better to play a defense which is scattered practically all over the court and which forces in proximity to the ball the moment it is lost.* This means that basketball is now played both offensively and defensively over the entire court as against the game of the last few years wherein our defense waited at mid-court."¹

The pressing defense slows down the offense and tries to force attacking players to make bad passes. The opponents are opposed just as quickly as the ball is lost. The defensive players are coached to rush and press but not to foul. Assigned opponents are usually disregarded since the closest defensive player attempts to check the competitor who receives the ball whether he has been assigned to him or not. Every defensive player guards the opponent to whom he is closest. Floor positions are not important. The players may play to the right, the left, between the ball and the basket, or any way they wish in making efforts to intercept the ball or cause a bad pass.

The rushing and pressing tactics delay the advance of the ball to scoring territory and in a great many cases the surprise of the attack forces the opponents to make bad passes or lose the ball. The defensive players play the man but also watch for the ball. They are coached to take chances and, in fact, more of the zone principles are in effect than man-to-man. The pressing tactics are used at all times, after an unsuccessful or successful shot, and following an out-of-bounds, held-ball, or free-throw play.

The best results are obtained when the opponent who recovers a rebound or catches the ball following a held-ball play is immediately checked. The pressing player should rush the man with the ball, flailing the arms and attempting to bewilder the opponent completely. This rushing often forces the man in possession of the ball to pivot and turn his back to teammates. In this poor passing position he is usually unable to throw the ball and a held-ball situation may result.

A number of the Western teams with exceptionally tall goal-tenders use this type of defense or offense, as you wish, in connection with certain zone defense principles. Two or three chasers apply pressing tactics to the oppo-

¹ Dr. Walter E. Meanwell, *Spalding's Basketball Guide*, 1927-28, p. 12.

nents as soon as the ball is lost. The two rebound-guards, one of whom is the goal-tender, retreat to the ten-second line and watch for the possibilities of an interception. If the opponents are successful in evading the chasers, the goal-tender and the other guard will retreat under the basket and try to stop a long or close shot. The chasers hurry back to support these two teammates with a zone defense which is formed and employed until the ball is obtained.

The pressing defense is a revival of the first defense of the game (man-to-man) but with several new principles. Instead of playing the man exclusively, the opponent is guarded with the idea of securing the ball. The pressing defense means that as soon as the ball is lost each defensive player will immediately contact an opponent and play him so closely that he will not be in a position to receive the ball or, if he is in possession, will not be able to make a good pass. The object is to intercept passes, score by means of the quick-break tactics, and then repeat the process. The entire philosophy of the offense is based upon advancing, never retreating; thus the term "pressing."

Since the pressing *offense* starts from any position on the floor and following any one of a number of situations which change during the progress of a game, most of the offensive measures are on an individual basis. The fundamental idea of the attack is to get the ball and a teammate under the offensive basket as quickly as possible. Anticipation plays a great part in this breaking toward the basket. Passing players often start for their own basket before a teammate has secured the ball. No particular paths are used in this sudden scoring dash and this demands that the players be masters of all passes so that the ball can be passed to a cutting teammate with a minimum of delay.

When forced to retreat under the opponents' basket, the pressing defense may continue its man-to-man guarding or adopt zone tactics. Most pressing defenses employ the screen-switch defense when forced to retreat under the opponents' basket. When an opponent's attempt for a goal is unsuccessful, the rebound is usually taken by one of the rebound-guards who starts the play by "pitching" a spot pass to one of the three front line players and the scoring rush is on. The attacking players spread their paths as much as possible and not infrequently the rebound-guard who did not secure the ball and make the first pass serves as a trailer in the dash for the basket.

Following a score by opponents the rebound-guard who recovers the ball hurries to either side of the basket and again uses a long pass to one of his front line teammates. Considerable latitude is given the passer in making the pass (catcher's peg), which may range from a short pass near the basket to a throw the entire length of the floor.

In most cases the receiver of the first pass looks for a teammate to whom he can forward the ball. The attack is built around a series of forward passes, usually made with one hand. When a player passes to a teammate, the original screening idea of pass-and-go behind the receiver is employed. The receiver, if checked, usually employs a complete turn or pivot to keep the ball moving in a forward direction.

It is to be expected that the quick-break will be slowed down at some

time and when this occurs some sort of planned formal offense may be used. The position of this formal set-up will usually place the fast pressing players near or under the basket. A set attack usually comprehends three players moving in the scoring area while the two rebound-guards are stationed in the rear court.

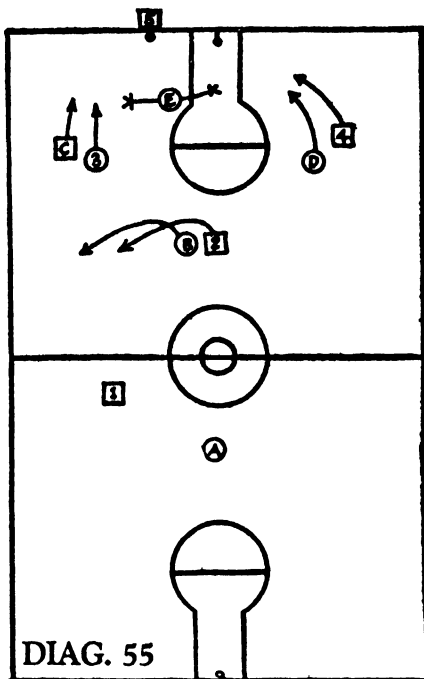
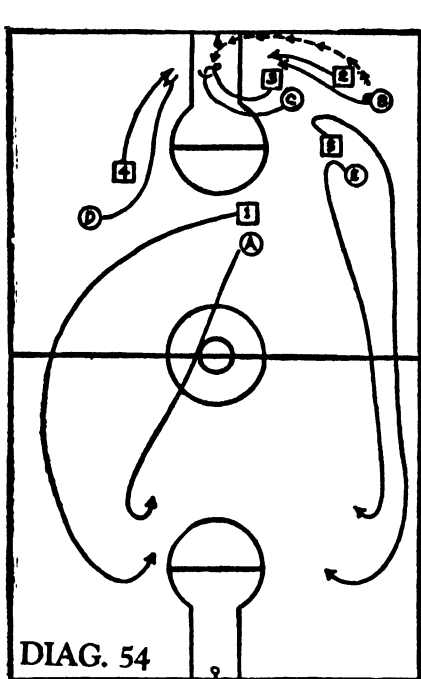

THE PRESSING DEFENSE FOLLOWING A REBOUND: Diagram 54. Attacking player B attempted an unsuccessful shot which was recovered by opponent 3. Before 3 could turn to make the first quick-break pass, he was pressed or guarded by opponent C. Teammates 2 and 4 tried to go to the assistance of 3 but they were followed closely by B and D, who played them in such a manner that an inaccurate or hurried pass might be intercepted. The two remaining teammates, A and E, had cut for their basket when their teammate 3 recovered the rebound. When the ball was not advanced down the court they turned to find that their immediate opponents, A and E, had taken positions between them and the ball so that a long pass from 3 would be dangerous. Although the guarding is aggressive, it is not designed to wrestle the ball away from the opponents. The pressing defense depends upon speed, surprise, and close guarding to force the team in possession of the ball to make a bad pass.

THE PRESSING DEFENSE AFTER A SCORE: Diagram 55. The attacking team has just scored and the rebound opponent, 5, has taken the ball out-of-bounds under his basket. He is not played closely by E but his teammates are being pressed everywhere they move. A long pass to 1 might be possible but the pressing safety guard, A, is no doubt anticipating this play and may try for the interception.

FLOATING PRINCIPLES: The development of floating in the man-to-man defense can be attributed to the shifting principles of the zone defense which was developed to counteract the overloading of certain territories by the offense. The five-man defense players probably used floating tactics before they were even thought of in connection with the zone defense.

Smart, intelligent man-to-man defense players undoubtedly adopted floating principles from the zone and applied them to individual guarding. Most basketball plays are developed around two or three players, which means that two of the offensive as well as two of the defensive players may be unoccupied for a short period. The defensive player who found himself without a guarding task in this situation began to float away from his opponent so that he might aid in congesting the area in front of the basket or possibly intercept a pass. He did not relax his guarding attention upon his respective opponent but indirectly tried to assist in the general team defensive play. Floating does not mean loafing. In reality it means the exact opposite because the floater assumes additional defensive duties.

Floating can be vertical or lateral and used by the individual or the team as a whole. When used individually it means that a defensive player (usually one who plays in the front court) has been chosen to use floating measures because his respective opponent is not too strong offensively or is charged with the rear court defense.

It frequently occurs that the quarterback of the offensive team maintains a standing guard position in his rear court, seldom cutting under the basket in an attempt to score. Unless this player is gifted with an exceptionally good set-shot, there is absolutely no reason why the defensive player who is opposing him should not float back toward his defensive basket when the ball has been advanced. In fact, a great number of defensive players have become so expert in this floating maneuver that their opponent and his teammates have played the entire game without realizing that he (the floater) was consistently breaking up their plays and intercepting passes.

When used as a team measure players may be coached to move laterally when the ball is on the opposite side of the court or vertically when it is on the side or near the basket. Floating tactics are particularly effective when opposed to a screen or give-and-go attack which tries to break offensive players into the area around the basket. Team floating resembles the zone principle of massing a number of players in front of the basket. However, the man-to-man principle of first concentrating upon the respective opponent and second upon the ball prevails.

When floating is used the defensive players must be cautioned concerning the dangers of blocking a teammate's path who is following a rapidly moving opponent. The congestion which accompanies team floating may often rebound to the advantage of the opponents because of their use of fast circulation. Defensive players in trying to keep up with their opponents may find a teammate in the way and allow a competitor sufficient time for a good shot.

Floating tactics can be used in defensive held-ball plays as well as when opposing an out-of-bounds play. Floating toward the basket usually discourages a pass or a cut by opponents.

SINGLE ASSIGNED FLOATER: Diagram 56. Defensive player 1 is the assigned

floater and has moved into the dangerous scoring area near the free-throw line. Because of scouting or game observance it has been determined that opponent A is strictly a rear court player who is in charge of the defense and serves as a post to whom teammates can throw the ball when they encounter attacking difficulties. The floater may be invaluable in congesting the scoring area in this situation and, if he is exceptionally clever, may play his opponent so deceptively that he (A) will not realize he is not being guarded.

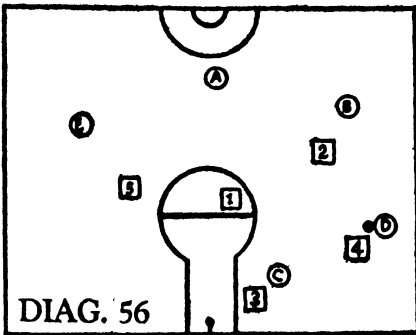

DIAG. 56

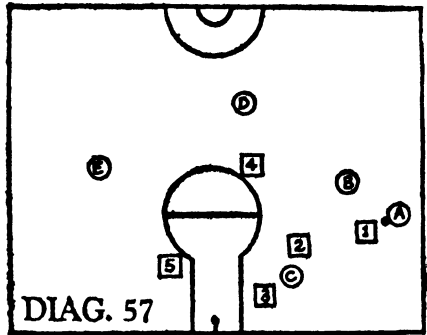

DIAG. 57

TEAM FLOATING: Diagram 57. Three of the defensive players are floating in this illustration and although the formation resembles one which might exist if the Two-One-Two zone was being used, man-to-man principles are in effect. Defensive 2 has floated away from his opponent B almost in front of the dangerous pivot scorer. Defensive teammates 4 and 5 have floated away from their respective competitors because they are removed from the action of the play and are standing still. Should B, D, or E receive the ball, move to another position, or cut toward the basket, they would be guarded closely by their respective opponents 2, 4, and 5.

COMBINATION DEFENSES: Combination defenses² are those which adopt and combine the principles of the man-to-man and the zone defenses. Such combinations may embrace the setting up of two lines of defense, one of which uses man-to-man principles and the other zone tactics. The number of men employed in each line varies as do the guarding methods. One principle is constant to the effect that the under-basket defense shall at no time be outnumbered. However, this principle does not apply to the front court. The offense is permitted to outnumber the front line of the defense. If the front line players employ zone tactics, naturally the ball will be played. If man-to-man defense methods are being used in the front line, the guarding of opponents may be individual in scope or embrace screen-switch principles.

Another type of combination defense is that which uses four men in the form of a box or diamond employing zone principles and one player using man-to-man principles to "dog" a high scoring opponent. The box or diamond players shift with the movement of the ball and keep their formation intact insofar as possible. The roamer is permitted to play as he wishes,

² Combination defenses as well as the box or diamond with the use of a roamer are considered zone in character. They are detailed in *The Zone Defense and Attack*, Chapter XVI.

chasing the ball, double-teaming an opponent, or concentrating upon a dangerous scorer or pivot expert.

THE MAN-TO-MAN DEFENSE WITH A GOAL-TENDER: The use of a tall player who can deflect shots at the basket may be utilized in the man-to-man or screen-switch defense. The goal-tender is stationed under the basket on the defense and remains there. His teammates use man-to-man or screen-switch tactics to oppose the remaining opponents. Floating methods may be used to mass near the basket and assist the jumper when the attack is centered there. Since the goal-tender can deflect the long shots, massing under or near the basket makes it virtually impossible for the opponent to secure a good scoring shot.

AN IDEAL DEFENSIVE SYSTEM: The basic principles of the man-to-man defense and the several variations which are popular should provide the tools to develop an ideal man-to-man defensive system. Inclusion or elimination of the variations which have been influenced by zone measures is a matter for the coach to decide. A knowledge of fundamentals such as body balance, use of hands, feet, eyes, and the voice is presumed to be mastered by all players. The following team defense may be considered too much to expect or attempt but perfection is always elusive.

First, the team should have a knowledge of the importance of defensive balance and the ability to maintain it; a quarterback should be responsible for its observance.

Second, the team should possess a thorough understanding of retreating and pick-up methods which enable the players to meet a slow or quick advance and definite principles with respect to methods of meeting an attack when outnumbered (the players will know exactly what is expected of them in all situations).

Third, the team should be practiced in the use of man-to-man principles of guarding assigned opponents (matching men), shifting only when forced into a screen or block which requires a switch to stop a score.

Fourth, the team should know how to use specialty rebound men who, because of shifting possibilities, can be kept under the basket for recoveries.

Fifth, the use of the front screen, the rear screen, the slide, and the switch as basic guarding principles should be mastered.

Sixth, the team should be familiar with the use of individual or team floating, depending upon the type of attack used by the opposing team.

Seventh, the team should be coached in tactics through which the dribbler can be forced toward the center of the court instead of the outside.

Eighth, the team should have a knowledge of the use of the rebound-triangle when opposed to a strong follow-in opponent.

Ninth, the ability to use the pressing man-to-man defense with screen-switch principles when behind in the score near the close of a game should be developed.

Tenth, skill in freezing the ball when only a short time remains to play and the point advantage is small is important.

Eleventh, definite principles with respect to stopping the quick-break should be mastered.

Part III. ATTACKING THE MAN-TO-MAN DEFENSE AND VARIATIONS.

CHAPTER VI OFFENSIVE PRINCIPLES AND SCREENING METHODS

IN PLANNING THE offensive principles for the team attack or attacks, the player abilities of the squad must be taken into consideration. The player is the essence and the style of play must be determined by his abilities and not vice versa. It is often possible to utilize more than one style of play with a particular squad. In some instances it is necessary to change the offense each year.

INDIVIDUAL PRINCIPLES: Before the team offense can function efficiently, the individual members of the squad must be assigned attacking duties which will permit their personal abilities to be utilized efficiently. Personal skills such as feinting, faking, cutting, shooting, passing, and dribbling must be thoroughly mastered before team play can be attempted. The ability to use screens, legal pivot and post blocks, and cutting methods is important in this preparation for team play.

A great many players possess special abilities which may be capitalized upon. For example, a pivot player may be an excellent scorer near and around the basket. It would be foolish to place him in the back court where he would have to start all over to develop new skills and scoring methods. The player with an excellent set-shot should be used in a shooting or rear court position where turn-around plays, clear-cuts, and give-and-go tactics may be used to provide opportunities for his specialty. The hard driving dribbler should, of course, be stationed in the back court so that he may have sufficient room to outdistance his opponents. Players with especially clever footwork ability should also be stationed in the rear court because feinting, maneuvering, and hard running tactics from this position may enable them to beat their opponents to the basket.

Player and coach are both vitally concerned in position development and the use of each player's abilities where they will best serve the team. In fact, a great many teams build their entire attack around one or two players with outstanding position abilities. Each individual player should recognize the importance of setting up plays for his teammates by screening, establishing a post or pivot, and serving as a decoy to draw the defense away from the point of attack. Change of pace, change of direction, the use of split vision, and deception are abilities which are important in this teamwork.

PASSING: Team principles with respect to long or short passes are im-

portant. The short passing game was probably most popularized by the German department of the Buffalo, New York, Y.M.C.A. (the Buffalo Germans). So successful was this team that high schools and colleges quickly adopted the short pass and the whole style of basketball play changed.

After players are taught to use the short pass they will learn how to handle the ball in congested areas and to accompany such usage by good footwork. When the long pass is used it is usually accompanied by long cutting of the players, meeting the ball at a high plane by receivers, and is, of course, best adapted to larger courts. The long pass is effective in the free scoring game and important in taking advantage of slow retreating methods by the opponents.

In most quick-breaks the first pass is long, followed by a number of short passes. In the use of a set offense passes may vary, depending upon the style of play in use. If give-and-go tactics are employed passing will be confined to back flips (one and two hands), back bounces, over-the-shoulder, the snap, hook, and the cross-body passes (overhand and underhand). These passes all blend in well with the man-ahead-of-the-ball style of play.

When a post or pivot attack is being used the baseball, the two-hand overhead, forward bounce, bowling, snap, and hook passes will be chiefly used. Furthermore, the coach may require that his players use certain passes in feeding the pivot man from particular points on the court. For example, from either of the corners a hook, overhead, or bounce pass with spin (English) may be used. The pivot player will require a number of passes to feed the players cutting by. His feeding duties usually limit him to use of the baseball pass accompanied by a step and turn toward the basket, one- and two-hand over-shoulder, back flips and bounces, as well as underhand "quarterback" passes.

SHOOTING: Team shooting principles are usually governed by the scoring abilities of the players. However, certain coaches have developed shooting methods that require uniform observance on the part of all members of the squad. For example, in the use of the set-shot all players may be required to shoot in the same manner. With respect to the one-hand shot, its use may be restricted at all points except in the vicinity of the free-throw circle. Banking may be required for all shots from certain positions on the sides of the court. (Uniformity is required in all shooting at Long Island University.)

When making free-throw attempts a number of coaches require all their players to shoot alike. Others permit them to shoot according to the accuracy they possess in a particular method. The chief problem seems to be concerned with the underhand and overhand shot. Undoubtedly the underhand is more natural than the overhand method. However, the underhand shot is seldom used in active play and probably the overhand free-throw can be developed to a high degree of accuracy because of its common usage during a game. Although there have been a number of players who had a high degree of accuracy from the free-throw line with one hand or with a two-hand overhead shot, these are considered to be "freak" shots and the coach would undoubtedly be wise to eliminate their use.

It is absolutely necessary that every player on the squad master those

shots which occur close to the basket. The under-basket scoring opportunities are infrequent and must not be wasted. Shooting principles will in most cases be governed by the wishes of the coach.

The "roll" or the wrist shot with or without a slight jump from the floor will depend upon the teaching belief of the coach. The use of pivot and turn shots by back-to-the-basket players in a great many cases depends upon individual proficiency. A number of fine pivot scorers use unorthodox methods in making the shot but if they are effective and consistent it is extremely doubtful if the coach will wish to change the style. Wild "heave" shots at the basket are usually forbidden at all times and by every coach.

DRIBBLING: A great many teams use the dribble as their chief method of moving the ball. When used in this manner it implies that all players will be coached to handle the ball with dexterity and finish with a good shot from any position. A great many coaches eliminate the use of the dribble except for certain game situations which have been defined and practiced. There is no doubt that the dribble slows down a quick-break attack and a great many coaches eliminate it entirely.

OFFENSIVE BALANCE: Offensive balance means that the player on the defense has the ability to change from defense to offense rapidly. Quick transposition demands that players be in or moving toward a position where they can break rapidly toward their own basket after an interception or following the possession of a rebound by a teammate. In the zone defense offensive balance is always present due to the fact that the players who take a leading part in the quick-break maintain more or less set positions in the front court. In the man-to-man defense it is unusual for a player to be stationed constantly in the front court unless he is opposed to an opponent who serves as a rear court quarterback and seldom drives under the basket in an attempt to pass or score.

In the screen-switch defense it is possible for certain defensive players to maintain a constant position in the front court because it is not necessary for them to follow opponents who cross in the attack. However, even these players may be drawn out of this quick-break position if the attacking rear court opponents drive directly toward the basket without crossing.

When floating tactics are used in the man-to-man or screen-switch defenses, there is a slight quick-break advantage because of the position the floater assumes in moving away from his opponent. A number of man-to-man defenses are coached to break to the offense while the ball is in the air and before it has actually been recovered by teammates.

QUICK-BREAK OR SLOW ADVANCE: A great many team offenses are built entirely upon the use of the quick-break and follow-in. As soon as the ball is obtained the quick-break begins and is continued with the aid of follow-in methods until a score results. No attempt is made to develop a set attack. Opposed to this quick advance is the delayed moving of the ball into attacking territory, during which period a position formation develops. Thereafter certain methods of passing, cutting, and shooting are followed in attempting to score.

Although a great number of teams use either the quick-break or the slow advance, depending upon the situation, it is difficult to master both styles thoroughly. Quick-break teams are too anxious to score to waste time setting

up a formation which will require a great number of passes and much maneuvering before a shot can be attempted. On the other hand, the team which usually relies upon a set formation from which to maneuver for scoring opportunities has usually devoted so much time to mastering the set attack technique that it thinks first of such methods for scoring and second of quick-breaking principles.

In both the quick- and slow-break, team offensive principles will govern the use of the long or short cut, pass, or shot. The dribble may or may not be used to advance the ball in either attack. Its use naturally reduces the speed of the advance since it is controlled by a player. It is obvious that a ball flying through the air will travel many times as fast as one which is limited by the speed of a dribbler.

FREE PLAY OR FORMAL PLAY: These principles would seem to compare with those of the possession or freedom attack. However, there is a considerable difference. Free play means that possession of the ball may or may not be important. Each player in company with his teammates is permitted to set up his own play situations. These will usually consist of two- or three-man plays or the use of individual abilities.

Formal play means that the action of players will be controlled by a series of planned passes and cutting paths which are designed to maneuver the opponents into guarding situations where one of the attacking players can break free for a good shot. If the scoring opportunity does not develop, the formation will be reassembled and an alternate or different play may be attempted. Although players in the formal type of play are allowed to use their individual abilities occasionally in attempting to score, the chief attack is built around the play habits which have been developed after many hours of laborious practice.

POSSESSION OR FREEDOM ATTACK: No matter what method of advance or attack is used, an important team principle is with respect to possession or freedom in controlling the ball. Spectators much prefer the freedom attack in which every effort is made to advance the ball rapidly and score without delay.

In the possession style of play the ball is protected until an unguarded shot is possible. This protection oftentimes comprehends an advance to a point directly under the basket and then returning the ball to the rear court to start the attack all over again. This may occur because the player did not feel the shot at the basket would be sure. Such tactics are tantalizing to the defense as well as to the spectators. However, when a team is composed of good passers it is fairly sure that they will win a majority of their games and certainly will lose no contest by a humiliating score.

SPECIALIZED OR GENERAL PLAY: The team style of play may incorporate the use of players especially trained for the various attack positions or employ rotation. In a specialized style of play certain men are designated as cutters and scorers; a rear court quarterback may be placed in charge of the defensive balance and assigned to feeding duties; one or two expert marksmen may be given set-shot responsibilities; and post or pivot men may be developed to assume the back-up positions in front of the basket through which passing and scoring may result. The post and pivot men are also required to master follow-in techniques. When specialized play is used the

coach usually finds it an easy matter to capitalize upon the particular abilities of certain players, thus lightening the coaching task.

General team play implies that each player will be able to maneuver from one position to the other and shoot, cut, pass, and dribble equally well. Although it is possible to use the special abilities which each boy may possess in this style of team play, yet he is required to devote a considerable amount of time to mastering new skills. It requires considerable coaching of fundamentals and in most cases uniformity in passing, shooting, and dribbling methods. It is probably the most efficient attack which can be developed.

SIGNALS AND THE QUARTERBACK: The offensive team can use signals to change its attacking method and the changes can be decided by the quarterback. This player should be stationed in the rear court and possess sufficient experience and leadership to change the attack when necessary. Names, numbers, or hand signals may be used to designate the various offenses.

SET ATTACK PRINCIPLES: The efficiency of set formations depends to a great extent upon whether man-ahead-of-the-ball or ball-ahead-of-the-man principles are used. For example, in the screening or professional type of give-and-go attack (man-ahead-of-the-ball) certain styles of play require that the center of the court and the area near and under the basket be kept open. The attack is directed toward creating defensive confusion in the rear court so that attacking players may cut into the unguarded area near the basket for a close shot.

Ball-ahead-of-the-man implies that a post or pivot player will maneuver in the area near the basket and that the ball will be thrown to him, after which his teammates will cut to or around him for a return pass. The post or pivot player is expected to score from his position as well as pass the ball.

CIRCULATION: Circulation entirely depends upon the attack being used. However, it is an important team principle and one which must be observed by all players if the offense is to be smooth in its application. All coaches are aware that the most effective scoring plays drive down the middle of the court. Because of that fact forward circulation is designed to strike toward the basket through the middle of the court and away from the basket along the sides. The figure eight attack originated by Dr. Carlson is used by 90 per cent of all teams employing a set offense. Another popular circulation method is the use of a circle which moves clock-wise or counter clock-wise and enables the attacking players to break toward the basket from any point on the court. Retreating paths, as in the figure eight, are near the side lines.

The team principle with respect to circulation will govern the movement of individual players. However, some latitude is proper when a scoring opportunity is present. In a give-and-go type of offense sudden stops, starts, pivots, half turns, and the change of direction are important in driving toward the basket. When a post or pivot attack is being used, cutting paths are directed toward the post or pivot man so that he may be used as a natural block into which the defensive players may be run. Here again no definite paths may be outlined since the chief purpose in driving toward the basket is to cause confusion among the defensive players. Cutting by rear

court players naturally is toward the basket, using a change of pace to drive inside or around the outside of defensive players. Pivot and post players drive laterally across the court, trying to meet the ball and then drive under the basket from the sides of the court. Not infrequently pivot men master the technique of driving out to meet the ball, faking a pass, and driving into the basket by means of a dribble.

Defensive balance rigidly defined requires the stationing or circulating of players so that there are at least two in the rear court whenever the ball is in danger of being lost. Some teams maintain two more or less stationary guards in the rear court at all times. Others assign one player as a quarterback who takes charge of assembling the defense. Undoubtedly the method to be used will depend almost entirely upon the attack employed.

FOLLOWING-IN OR RETREATING: There is a saying in basketball that the team which controls the backboards controls the game. This pretty generally holds true. Coaches are ever on the lookout for players who seem to have the native ability to time their movements and leaps so that they are able to recover a ball from the offensive backboard or at least cause a held-ball situation and when on the defense are able to guarantee sure possession. However, certain team principles do not encourage this following-in while on the attack, preferring to secure a good shot and then retreat to guard against quick-break possibilities. It is certain that few teams can combine follow-in and retreating methods efficiently since the teamwork which is required in one type of play is inconsistent in the other.

Following-in has several advantages. If the players assigned to this duty are strong and possess good timing, scoring may result and, in addition, the quick-break attack of opponents may be checked. However, there is a danger attached to the follow-in if the players are not aware that they have defensive responsibilities. If the ball is not immediately secured, further follow-in approaches pressing methods, which means that the entire burden of the defense will be upon the teammates who have retreated to the back court. Since a great number of follow-in men are chosen because of their height and weight, it may be easy for the opponents to outspeed them in reaching the other end of the floor and the players who have retreated on the defense may be outnumbered.

When retreating tactics are pursued following a shot, the defense can be formed quickly. Assembling near the ten-second line, defensive players may then adopt aggressive defensive principles to disturb the efficiency of the opponents' attack. This retreating also serves to slow down the quick-break because there is little opportunity for competitors to establish outnumbering.

CHANGE OF PACE: Change of pace is just as important to the team offense as it is to the individual. Every player recognizes the advantages of changing speed while dribbling or cutting toward the basket. Team change of pace means that the attack will incorporate quick-break methods, for example, during the first five minutes of the game, then change to a possession attack for five minutes, and then possibly use a post or pivot attack. Naturally, coaching philosophies oppose a change of tactics so long as they are successful. However, it usually holds true that good defensive teams will meet

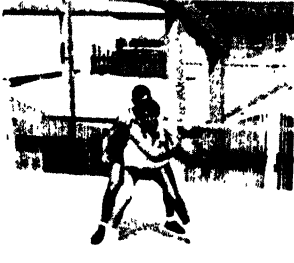

171



172



173

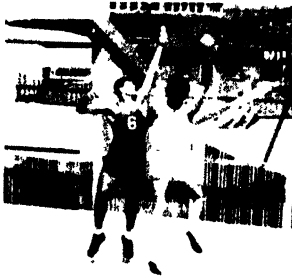

174

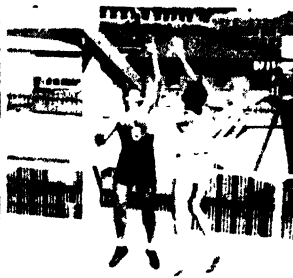

175



176



177



178



179



180

171—175. The pivot player is using a step-away and turn-shot.

176—177. Although the defensive player is crossing his feet in guarding the dribbler he is in a good position.

178—180. The three players in white have formed a rebound-triangle under their opponent's basket and should be able to secure the ball.

Owen Reed

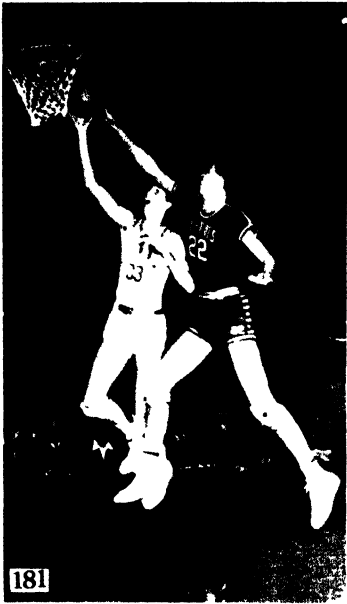

181



182

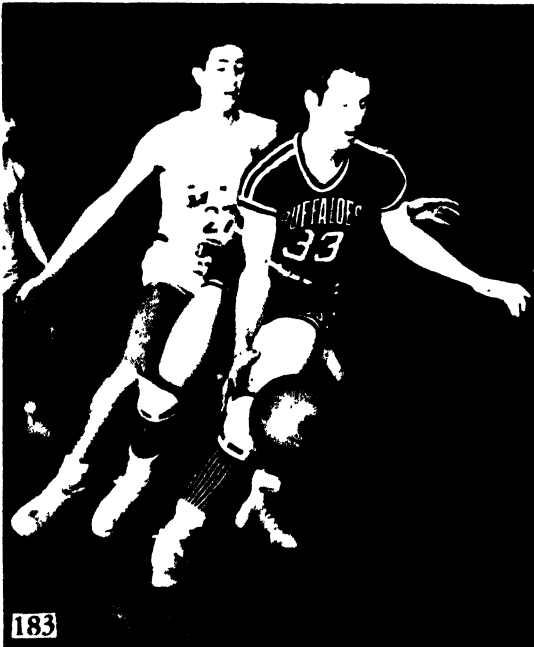

183



184

181. Charlie Halbert of West Texas shows excellent guarding technique in deflecting a shot attempt by Dick Holub of L.I.U.

182. Don Raese of West Virginia University recovers an offensive rebound and drives around Henry Beenders, L.I.U. captain, in order to protect the ball.

International News photo.

183. Lennie Rader, L.I.U., uses good guarding technique in forcing Frank Stockton, of West Texas, to retreat from the basket.

International News photo.

184. The underhand lay-up shot is undoubtedly the most natural and accurate shot when traveling at top speed.



185

186



187



188

185—187. The defensive player (white suit) is maneuvering around and about the pivot player in an attempt to discourage or intercept passes. Defensive players now guard dangerous pivot scorers in front, on the side, and in other unorthodox positions in attempting to prevent an underbasket score. Heavy guards often force the pivot scorer away from his favorite scoring position. *Owen Reed* photo. 188. Both jumpers in this center tap situation have watched the ball and have reached their maximum jumping height with straight extended arms.

Wide World Photos, Inc.



189. "Sandwiching" is as important after a shot as before. The two Oregon players will undoubtedly take the ball away from Simon Lobello of L.I.U.

190. An opponent has been doubleteamed by Bill King and Arthur Hillhouse of L.I.U. Note the position of the body of the player about to secure the ball.

191. The St. John's pivot player is executing a perfect under-basket hook-shot. Most pivot players attempt a "hope" shot without locating a carom spot on the board.

Acme photo.

International News photo.

the efficiency of the offense after a period of time and then team change of pace will be valuable.

PLANE OF PASSES: Because of the day after day practice players may develop a liking for particular passes. This favoritism usually carries over into games. It should be a team principle that certain passes accompany different attacks and are to be used in varying planes. For example, in opposing a tall team it would be wise to use the bounce, the underhand, and various forms of flip passes, whereas in attacking a team composed of short or smaller players the use of passes on a high plane probably would be more effective.

Screening and Rear Court Attack Methods

Following the development of the quick-break in early basketball, the triangle play made its appearance. This triangle laid the foundation for the professional type of offense which depends to a great extent upon give-and-go tactics. Shortly after the development of the give-and-go plays, the screen attack developed. As originally used, the screen was developed by players cutting behind their teammates in such a way that their respective guards were forced to pass on the other side of this teammate and in some cases behind the teammate and his guard. "Pass and go behind" was the slogan for this type of screen play.

A little later screening entered another phase in which players moved in front of teammates. This was used to form a screen between the teammate and his respective guard. This use of the screen principle is the foundation for the modern rear court attack. Screening between a teammate and his guard is often carried to such an extreme that the whole procedure resembles squirrel-in-a-cage tactics. Much running results but little progress is made.

Although a screen attack may require the movement of all five players, most successful plays develop around two or three players at the most. In the give-and-go attack the best results are usually obtained when the plays are limited to two men. Undoubtedly the present day use of professional give-and-go tactics is due to the fact that little practice is required. Every professional player understands the use of give-and-go plays and this is probably the reason a player may be a member of several teams combined of different personnel and yet blend more or less perfectly with the style of play.

Professional players prefer to keep the center of the offensive court clear so that they may get their opponents off balance by feints, fakes, change of direction, and rear court screening and then outrun them to the basket where a pass may result in a score. However, a great many high school and college teams have combined screening principles with the use of the post and/or the pivot. When thus used the screen assists materially in permitting passes to the back-up players which might not otherwise be possible. After the ball has been passed ahead to a post or pivot player the screen may be used to get an opponent off balance and then the teammate with the ball can be used as a legal block. In attempting to avoid the post or pivot block, the defensive player may cut to the rear of the post player, leaving a two-man screen between himself and his opponent. Chiefly be-

cause of the contact and the fact that some defensive players were forced to move behind the post or pivot block, the defensive switch developed.

TEAM SCREENING (Figure Eight Attack): The deep figure eight attack (familiar to every coach of the game) employs a number of screens in which each player passes the ball to a teammate and cuts horizontally toward the corner he is facing. This cutting from right to left and left to right continues and results in the shifting of defensive players.

Most teams use this deep figure eight for circulation purposes but restrict the actual moving and handling of the ball to a three-man continuity. These three men screen for one another, using lateral, vertical, or horizontal figure eight paths to develop plays. The two men who are unoccupied in the three-man screen usually take care of the defensive balance. However, they may replace a teammate and take part in the continuity at any time.

The general circulation principle of this screening attack requires that the player who passes follows the ball and the receiving teammate advances toward it. In following the pass the passer is expected to screen between the teammate who receives the ball and his immediate guard. Exceptions to this rule may occur when post or pivot men are included in the continuity. The receiver of the pass has the option of returning the ball to the cutting teammate or passing to the third member of the continuity. If neither of these possibilities is attempted, the receiver may start yet another continuity by passing to one of the two players who are not immediately engaged in the screening attack.

Although the attack attempts to keep the ball moving rapidly from one player to another, it is frequently necessary to use the dribble. Some coaches eliminate the dribble altogether or have a special series or continuity which embraces its use. Against a tight man-to-man defense the screening and figure eight continuity are unusually effective. When opposed to a zone or screen-switch defense it is probably less efficient unless a post or pivot player is used.

GIVE-AND-GO (Two- and Three-Man Plays): As in the figure eight attack, best results will be obtained in the give-and-go attack if its use is limited to two- or three-man plays. Although it is preferable to keep the court open, a post or pivot player may be used in this attack to good advantage. When a post or pivot player is employed he is used chiefly as a legal blocking obstruction around which the give-and-go players may cut. This usage does not comprehend feeding or scoring duties. Expert rear court give-and-go players prefer to keep the center court open, depending upon their trickiness and maneuvering abilities to throw their opponent off balance so that they can secure an advantage of a step or two in breaking toward the basket.

Since the give-and-go attack is designed to feint defensive players off balance, rapid movement of the ball is not as important as in the screening attack. In fact, players oftentimes hold the ball for a considerable length of time and then dribble into the basket in an attempt to score. This is often possible because teammates will maneuver their guards and themselves into positions around which the dribbler may drive. (Play without the ball is important in developing scoring situations but it is difficult to impress the fact upon some players.)

In cutting from the rear court toward the basket, a number of paths

which may be termed the "S," "L," and loop can be used. Some attacks go so far as to use hand and arm signals to signify in which direction they will cut. Even when the arms are not used as a medium for signals, practically all professional players extend one arm or the other as a guard for their opponents and as a target for passes from teammates.

Give-and-go players like to be played closely. In fact, they often use tantalizing or teaser tactics to inveigle opponents into transferring their weight forward so that a start can be secured before competitors can shift their weight back toward the basket. The usual plane of passes in this type of game is low. Players endeavor to keep the ball close to the floor and protect it by the use of the body. However, high and fast passes may be used when the player is cutting toward the basket. Rear court maneuvering requires the use of a great number of over-the-shoulder, back bounce, back flip, behind-the-back, and hook passes. Change of pace, change of direction, sudden bursts of speed, turns, and pivots play an important part in this offense. A few of the cutting methods are shown in the six series which are illustrated in Diagrams 58 to 63, inclusive.

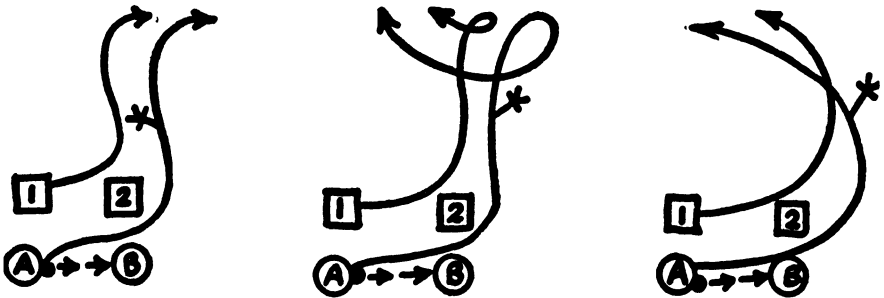

DIAG. 58

GIVE-AND-GO PLAYS. SERIES 1: Diagram 58. The "S," "L," and loop cuts are shown in this illustration. Player A passes the ball to B and screens in front of defensive 2. Continuing toward the basket, A uses the cutting path he believes will free him from his guard. When A expects to finish his cut to the right of the basket, he raises his left arm, and when a path ending on the left side of the basket is used, his right arm is extended.

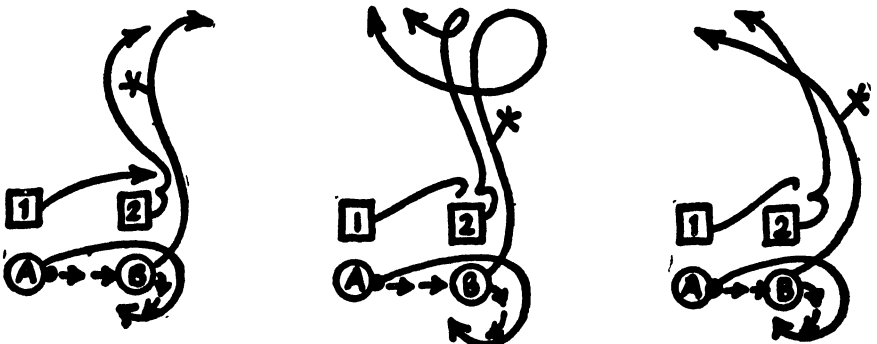

DIAG. 59

GIVE-AND-GO PLAYS. SERIES II: Diagram 59. Player A passes the ball to B and screens in front of 2. Instead of continuing on toward the side line, A reverses direction to the rear of B and receives a return pass. B then cuts toward the basket, providing a "clear-out" which may give A time for a set-shot.

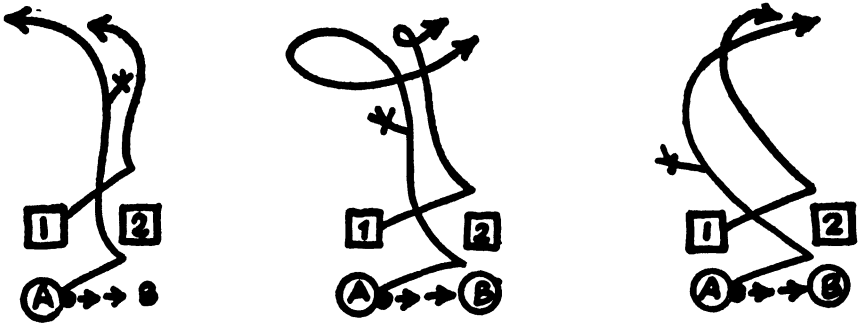

DIAG. 60

GIVE-AND-GO PLAYS. SERIES III: Diagram 60. A passes the ball to B and uses a change of direction to drive toward the basket. B may shoot or return the ball to A if he succeeds in breaking away from his guard. The extended arm serves as a target for the pass.

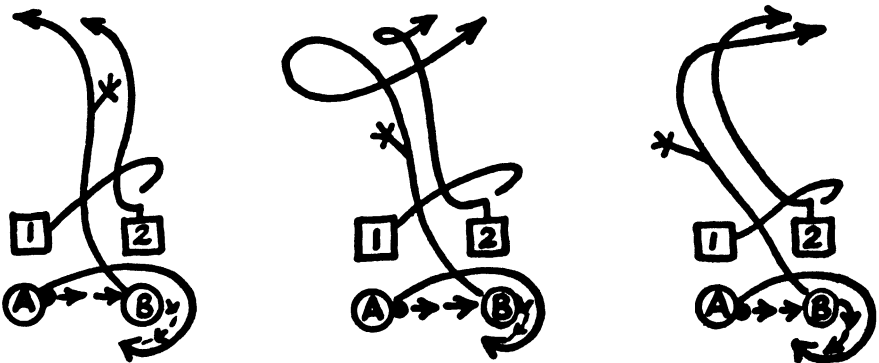

DIAG. 61

GIVE-AND-GO PLAYS. SERIES IV: Diagram 61. A passes to B and reverses direction as shown. B fakes to the right, uses a back flip, bounce, or over-shoulder pass to return the ball to A and then follows the "S" "L," or loop path to drive toward the basket. A may shoot or pass the ball to B. The arm which B extends over his head is used not only as a signal to advise A on which side of the basket the ball will be expected but to serve as a target for the pass.

GIVE-AND-GO PLAYS. SERIES V: Diagram 62. A passes the ball and uses a reverse roll to move to the rear of B. The ball is returned to A just before B cuts for the basket, using one of the paths shown. This type of clear-out may provide time for a good set-shot by A.

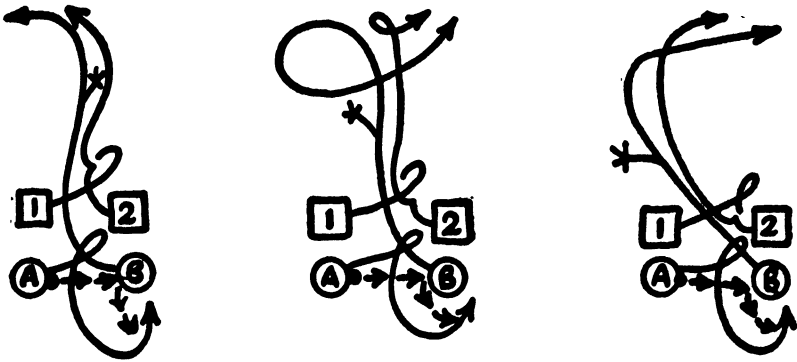

DIAG. 62

GIVE-AND-GO PLAYS. SERIES VI: Diagram 63. A passes the ball to B and moves toward defensive 2. Just as he reaches a position slightly to the left of B, A spins or feints a change of direction and then continues forward as shown. He extends his arm above his head as a signal to indicate the direction he will cut and attempts to outrun his opponent.

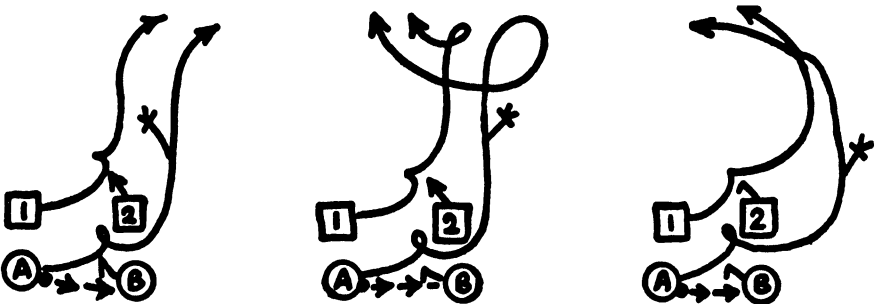

DIAG. 63

CHAPTER VII

THE QUICK-BREAK

To THE AVERAGE spectator the quick-break is simply a series of passes and cuts by players who drive at full speed toward their basket. Although it is lightning fast, hard driving, and exciting, the quick-break does not represent a harum-scarum, careless, unplanned drive toward the scoring zone. Successful use is obtained only after many hours of patient drilling.

The idea, of course, is to get the ball into scoring territory before the opponents can assemble their defense. Outnumbering is the chief objective so that two-on-one, three-on-two, or greater advantages can be accomplished. The quick-break has two chief advantages. First, it is the most rapid and efficient method of scoring. Second, it serves as an excellent check on the

attacking plans of the opponents since they must constantly think of defense even in the midst of an offensive play.

Speed is the primary requisite for successful operation of the quick-break once it is under way. However, securing the rebound from the defensive backboard and getting the ball into the hands of the breaker is probably the most important element in the attack. For that reason few quick-breaks have been successful unless one or two strong rebound men were available for the under-basket recoveries.

In some cases an exceptionally tall player has been able to take care of the rebounds and the first quick-break pass successfully. However, when the opponents use follow-in tactics to circumvent a single player's rebound effectiveness, the use of another defensive player to assist in the rebounding and also to block out is necessary. The old method of securing the rebound and dribbling toward the corner before making the first pass is obsolete and no longer effective in the use of the quick-break. Since the entire time required for a successful quick-break requires not more than five or six seconds, it is obvious that dribbling to the corner uses up valuable time.

There are situations, of course, in which the rebound-guard is not able to make the first pass and then it is necessary that he use the dribble in order to advance the ball up the court. In such cases it may be necessary for him to use the dribble-out method but he should be instructed to get rid of the ball as quickly as possible. (The dribble distance between baskets is so great that dribbling will require too much time for success.)

The first quick-break pass can be thrown to the sides of the court, to the center, or in the vicinity of the free-throw line. In some cases it is possible to use a long loop pass the entire length of the floor. However, the accuracy required and the interception dangers are too great for such usage by the average squad.

In the zone defense an exceptionally tall player is often used in the front line as a receiver for the first pass. A tall player can also be used to take the first quick-break pass in the man-to-man defense providing the assigned receiver method is being employed.

As soon as the first pass is in the hands of the breakers, ball handling ability becomes important. Not every basketball player is able to master the technique of handling a basketball while moving rapidly and herein lies the danger of the quick-break. Players must be taught to throw the ball while moving at top speed so accurately that it will not be fumbled or lost and also so opponents cannot make interceptions. The ability to change direction, to dribble, and to size up the attack which is necessary in meeting the defensive alignment are special qualities which are not found in all players.

When arriving in the scoring zone a number of shots are possible. Most coaches, of course, prefer that the players drive close and underneath the basket for the shot attempt. However, many successful quick-breaks rely upon the one-hand shot which is attempted from any point on the floor up to twenty or twenty-five feet. Such shooting is usually accompanied with a strong follow-in by breaking teammates. Unless the players who take long one-hand shots are exceptional marksmen, it is doubtful if the method can be considered efficient.

There are two chief methods of advancing the ball—by straight lines and through criss-crossing. The use of long or short passes as well as dribbling and pivoting in either of these attacking styles is optional. A number of coaches believe the dribble takes too much time, some feel the long pass is too dangerous, while others think the pivot is not necessary. Nevertheless it is important that players be drilled in use of all the individual fundamentals and then blended into a quick-break style which can be practiced religiously.

Quick-break efficiency depends upon several team principles. First, the defensive alignment should be such that the change to offense can be made with lightning speed. The break is made from every defensive situation—interception, loose ball, rebound, held-ball, an out-of-bounds play, and following a successful or unsuccessful free-throw by opponents. Second, a number of receiving points to which the first pass can be made from the recovery positions must be learned so there will be no loss of time in getting under way. Third, the paths which will be followed from each of the receiving points should be clearly defined to eliminate confusion when the attack reaches scoring territory. Fourth, and most important, is the mastery of a number of short shots while traveling at full speed.

Needless to state, the success of any quick-break style depends primarily upon the individual abilities of the players. Co-ordination, handling the ball while traveling at top speed, accuracy in passing to a moving target, and quick thinking are absolutely necessary. Players favor the quick-break because of the possibilities for personal initiative. Spectators like it because it presents action, speed, and rapid scoring. Coaches use it because it is the quickest and easiest method to score baskets—and it wins games.

A number of quick-break styles use the dribble exclusively. The dribbler usually drives down the middle of the court to the free-throw line where he stops and attempts a shot or feeds cutting teammates.

An excellent exception to this use of the dribble is that popular with a number of Southern teams. All players strive to get the ball to the star dribbler as quickly as possible. Two or three receiving points are decided upon and teammates look for the dribbler as soon as they get the ball. They then pass to him and he dribbles down the side of the court, trying to unbalance the defense. When this is accomplished, he passes the ball back to a teammate in the vicinity of the free-throw line. This player shoots or passes forward under the basket. The advantage of this style lies in the ability of the dribbler to drive the defense back and to one side of the court, leaving openings around the free-throw line and under the basket.

Make no mistake about it—the quick-break is a distinct offense. Careful and thorough coaching effort is required just as consistently as in teaching an involved screening or post attack.

RECEIVING POINTS: Diagram 64. Good receiving points for the first pass, long or short, are shown here. Once the ball arrives at these points the planned and practiced cutting paths will aid in eliminating lost time. Naturally, many break situations occur when time and opportunity do not permit the use of a standard pattern. Success in these instances will be determined by player abilities and initiative.

THE LONG PASS QUICK-BREAK: Diagram 65. This illustrates the extremely

long pass used by a number of teams when they are fortunate in possessing a good "pitcher." If opponents do not possess defensive balance, this break method is demoralizing. Interceptions and out-of-bounds passes are possibilities which make its use doubtful unless the rebound-guards are exceptional passers.

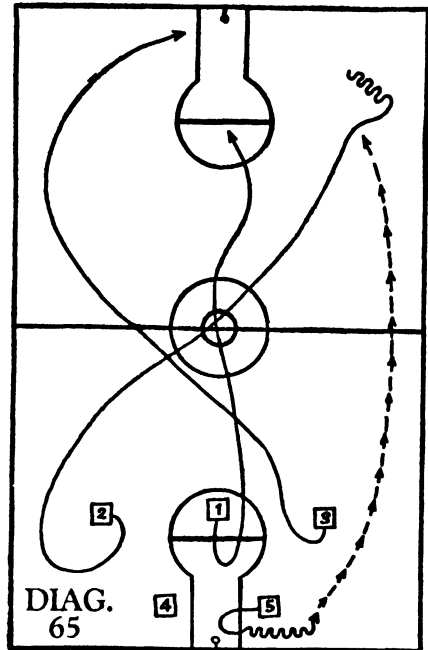
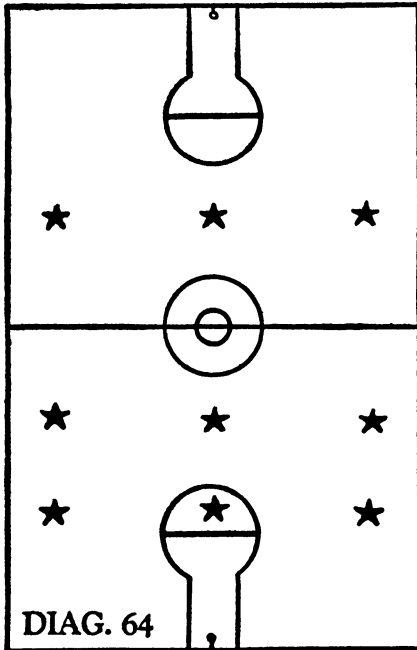

LONG PASS TO SIDE: Diagram 66. Guard 5 recovered the rebound and passed to 3, who broke fast up the side line. The center player (1) cut down the middle, player 2 down the other side of the court, and the break developed as shown. Rebound-guards 4 and 5 followed as "trailers" and to protect the rear court.

SHORT PASS TO SIDE: Diagram 67. Rebound-guard 4 recovered the ball and passed to his teammate (2) near the side line. The ball was then passed rapidly to 1, on to 3, back to 1, and finally to the original receiver 2, who fed 3 cutting under the basket. This is a fast-passing, no-dribble break, and when accompanied by a trailer (4 or 5) very effective.

SHORT PASS TO FREE-THROW LINE: Diagram 68. Defensive 5 recovered the ball and hooked it to 1, who passed to 3. The ball is passed like a "hot potato" from one player to another. No dribble is permitted. Frequently the rebound-guard is unable to pass the ball to a teammate. Use of the dribble-out is recommended in these cases. Bringing the ball down close to the floor, the guard practically drives a path through the opponents until he reaches the open, then he passes to a teammate. It is not generally wise to permit these rebound-guards to dribble down the court. (Tall players are usually poor dribblers.)

CRISS-CROSS WITHOUT PIVOT OR DRIBBLE: Diagram 69. This method is used in an attempt to shift opponents. The dribble and pivot are not used. It

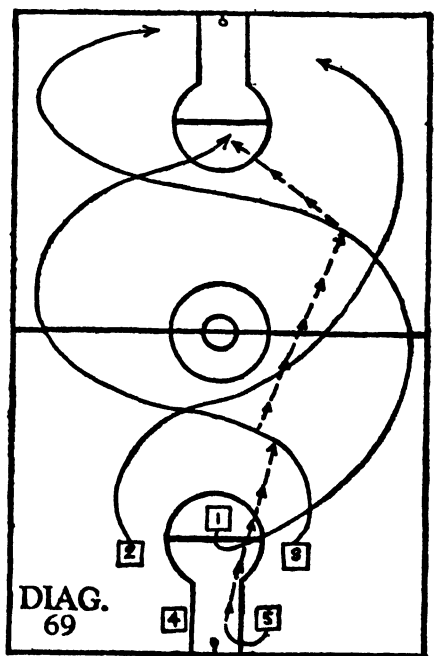
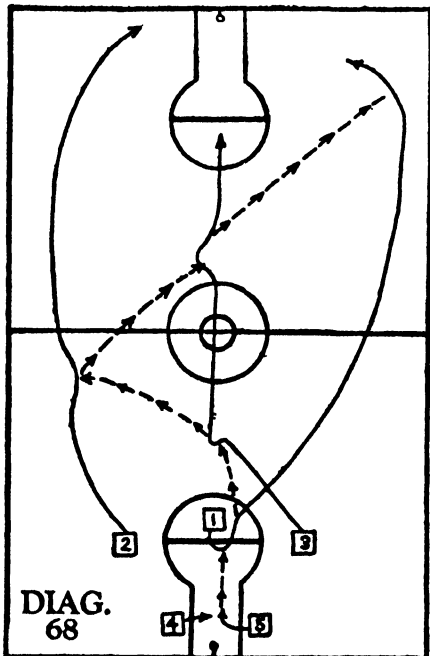
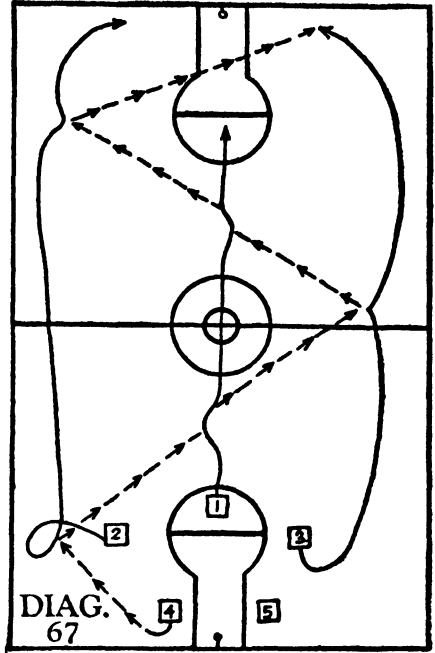
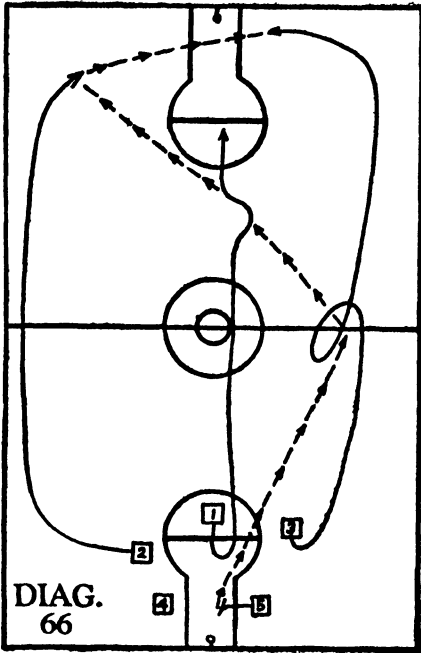

requires tremendous speed and the ball must be passed immediately. Trailers (4 and 5) drive straight down the court to the basket. The rebound-guards are also used for safety purposes when necessity forces backward passing of the ball. A long forward pass should follow these back passes to make up for the interruption in progress toward the basket.

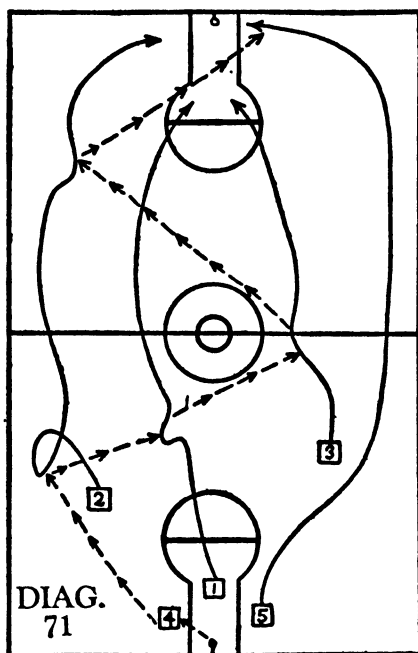
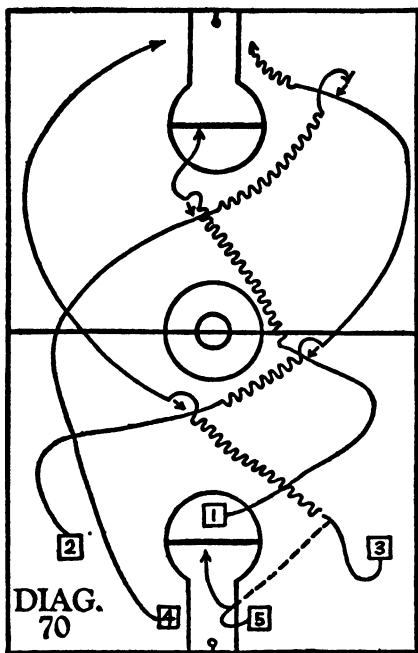

CRISS-CROSS WITH PIVOT AND DRIBBLE: Diagram 70. Player 5 recovers the ball and passes to 3, who dribbles up and across the court until checked by an opponent. He then pivots, ready to pass to 1 or 2, who were waiting for him to stop. The ball was passed to 2, who continued as shown.

THE STRAIGHT-AWAY QUICK-BREAK: Diagram 71. In this style of play the break starts with a minimum loss of time. Each player drives toward his basket in a straight line from the position in which he is located the moment his team secures possession of the ball. The first pass is long and thereafter the ball is kept moving between players without the use of the dribble. The player who recovers the rebound follows up the court to take charge of the defensive balance. The last player to get under way serves as a trailer to whom teammates may pass when they reach the scoring zone, providing the defense stops their scoring attempts.

QUICK-BREAK FROM HELD-BALL: Diagram 72. Most teams use their regular quick-break style following an interception, rebound, or possession of the ball after a jump play. In this illustration players 1, 2, 3, 4, and 5 set up a defensive formation. The jumper secured the tap and 5 passed immediately to 4 (the defensive player farthest removed from the basket), who dribbled to the foul line. In this quick-break the front line of the defense, 1, 4, and 5, serves as the front line of the attack. Teammate 2 acts as a trailer while rebound-guard 3 assumes a position in the rear court for safety purposes.

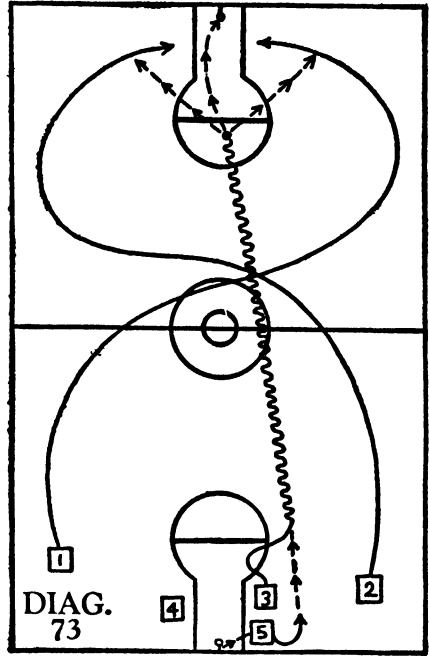
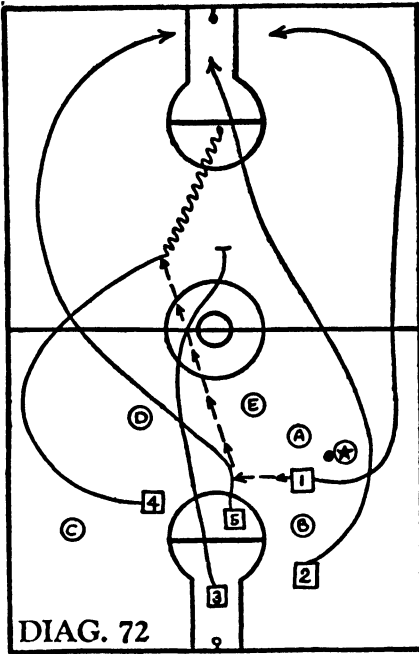

THE QUICK-BREAK FROM AN UNSUCCESSFUL FREE-THROW: Diagram 73. Rebound-guard 5 recovered the missed free-throw and passed immediately to 3. He (3) then dribbled to the offensive free-throw line. The first pass in this situation is well protected because the opponents usually station two players in the rear court for defensive purposes and two players under the basket. In case the opponent attempting the free-throw does not retreat rapidly to the defense, his rear court teammates will be outnumbered by players 1, 2, and 3.

LONG FORWARD PASS: Diagram 74. A number of teams attempt quick-break tactics immediately after their opponents have scored. Since the competitors usually have time to establish defensive balance after a score, quick-break possibilities are limited unless the first pass is an extremely long one. In the illustration 5 recovered the ball immediately after it had dropped through the basket, stepped out-of-bounds, and threw a long pass to his teammate 2 who had cut horizontally across the front court. Player 1 also cut across court so that the pass could be made to him providing 5 had taken a position on the left side of the basket after securing the ball. The rear court defenders (3 and 4) also crossed so that 5 might pass to them as alternates if necessary.

BREAK-OUT DRIBBLE: Diagram 75. When follow-in tactics are used by opponents in an effort to stop the first quick-break pass, a rebound-guard may frequently be called upon to dribble-out from under the basket. In this illustration rebound player 1 recovered the ball and literally forced his way through the opponents by means of a hard dribble. As soon as he reached the open, he passed the ball to 3 and continued on up the court, endeavoring to assist in establishing a three-on-two situation.

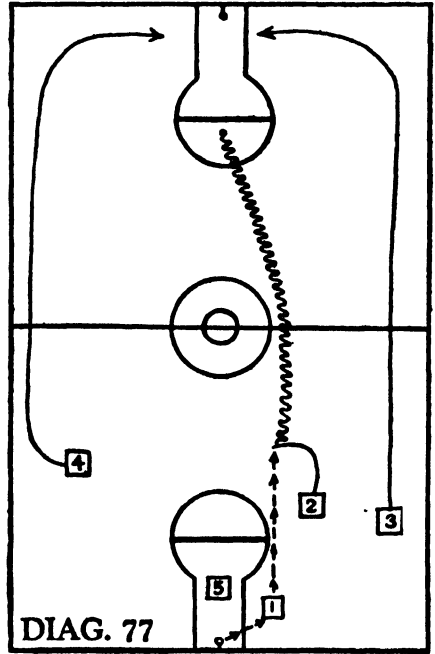
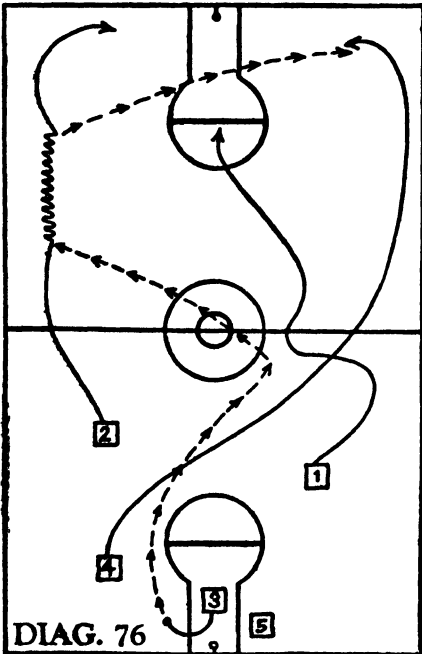
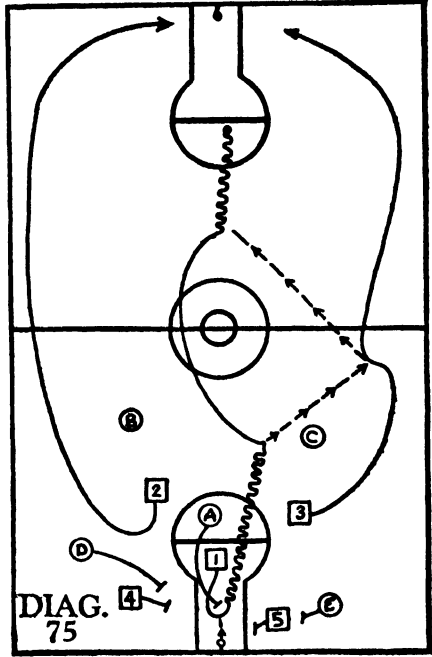
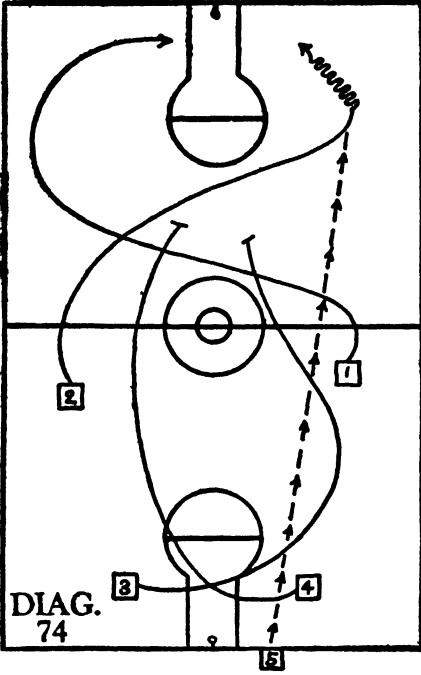

CENTER CIRCLE PASS: Diagram 76. Rebound-guard 3 used a spot pass to the center jump circle to throw the ball to whichever teammate succeeded in eluding a rear court guard. In the illustration player 1 received the pass and his front line teammate 2 cut down on the other side of the court. Player 4, who was in the next best position to assist in the quick-break, cut down the right side line.

THE THREE-LANE WITH THE DRIBBLE: Diagram 77. This method of advancing the ball is popular with teams possessing a versatile player who is an excellent shot and passer from the vicinity of the free-throw line. Rebound-guard 1 secured the rebound and passed immediately to this "designated" receiver (2). The designated receiver would generally be found in the vicinity of the free-throw line, although it might be necessary for him to follow different paths in arriving there because of a pressing opponent. After securing the ball this player dribbled hard for his own free-throw line. His teammates 3 and 4 cut down the side lines and made almost a square turn when they arrived at the corners so that opponents could be maneuvered between the ball and themselves. As soon as the dribbler arrived at the free-throw line he attempted a shot. If he was guarded, the ball would be passed to one of his teammates under the basket.

Auxiliary Plays

The zone defense possesses an advantage in meeting auxiliary plays. No particular opponent must be watched and the nearest defensive player guards the man out-of-bounds or the dangerous under-basket opponent. Then too, it is much easier to move between the ball and the basket in the several situations than it is to find an assigned opponent and secure a good guarding position under the stress of rapid play. Auxiliary plays may, therefore, be regarded as more effective against the man-to-man than the zone defense.

The general opinion of coaches is that auxiliary plays should be taught only after the basic defense and offense fundamentals and principles have been thoroughly mastered. However, a team cannot be regarded as completely equipped unless it can employ offensive and defensive tactics in the auxiliary play situations. Undoubtedly the success of auxiliary plays is due more to the surprise or suddenness of the attack than to the development of intricate screening and blocking assignments.

The fact that a team sets up formations and plays for the auxiliary situations has a psychological effect upon the opponents. They are then inclined to be defense-minded and may not concentrate upon securing the ball. Most teams are wary of a formation which is set up even though it is formal in its application. This feeling of wariness is a great aid to the opponents and permits them more latitude in securing possession of the ball. (Most coaches are more than satisfied to secure possession of the ball at the center jump, in a held-ball situation, from an out-of-bounds play, and following a free-throw.)

CENTER TAP PLAY: Before the center tap was eliminated following a score (1937-1938 rules), tap plays occupied an important place in the team offense. Practically all coaches developed a great number of plays and several forma-

tions to take advantage of tap control or to compete against its domination by opponents. Most of the plays followed the quick-break pattern and their success was usually due to the speed of the long pass and long cut. Few coaches today spend time in developing plays because the situation occurs no more than three or four times in a game. However, a scoring or defensive formation may be important at certain stages of a contest. Signals and receiving points are still important in jump plays chiefly because of the frequency of held-ball situations.

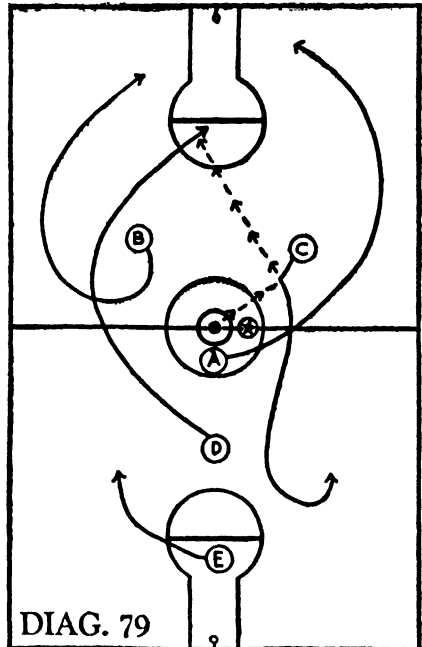
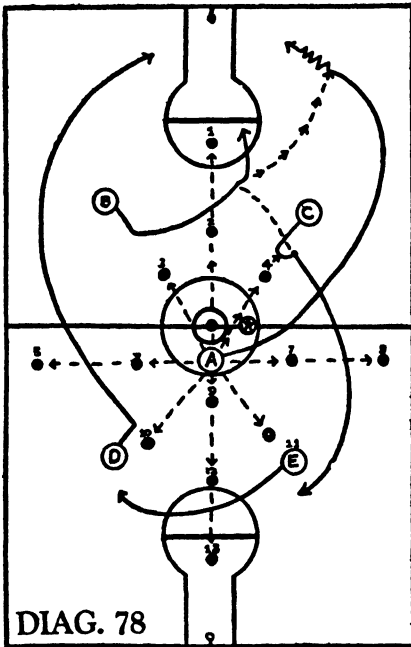

CENTER TAP RECEIVING POINTS: Diagram 78. The points to which the ball may be directed when the tap is controlled are outlined. The deep front, side, and back taps are aimed for points 1, 5, 8, and 13. Intermediate and possession taps are directed to the closer points.

The positions assumed by B, C, D, and E, represent the formation which is generally used when the control of the tap is certain or fairly even. The diagram may be used to develop a number of plays from this formation. In the illustration A tapped the ball to C at point 4. Forward B started toward the center circle but as soon as he saw that C would secure the ball safely changed direction and cut for his basket. C passed the ball to B near the free-throw circle and then continued to the back court to set up the defense. Guard D cut down the left side line while the center (A) cut around the official and down the right side line. E moved to the left side of the back court to set up defensive balance. This formation can be used to steal the tap by means of rotation methods but the forwards, C and B, must direct their cuts toward the back court so that they will be in a defensive position should their efforts prove unsuccessful.

THE "Y" FORMATION: Diagram 79. This formation is usually employed

when the tap is controlled. The positions of B, C, and D, are excellent for the development of center plays. In the play illustrated, A tapped the ball to C at point 4. D cut into the front court when he saw that the tap was safe and in company with A and B cut toward the basket and attempted to score. C and E set up the defensive balance.

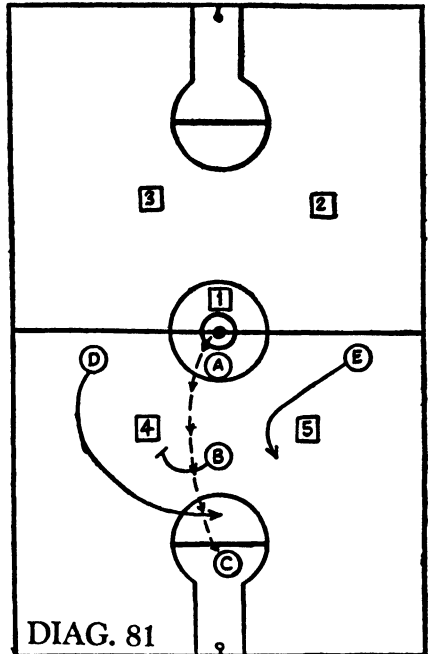
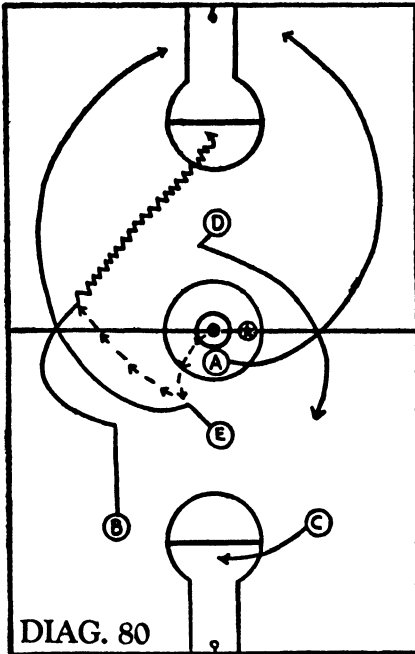

THE INVERTED "Y" FORMATION: Diagram 80. This is a defensive formation which permits D and E to attempt to steal the ball. Although the opponents may control the tap and secure the ball, the formation is too strong for their plays to work efficiently. Offensive plays may be worked from this defensive formation. In the illustration A back-tapped to point 10 where E met the ball high in the air and passed to guard B who had cut up the court. D had started to his right to protect the tap but changed direction and joined C in the back court defense. B dribbled to the free-throw line while E and A cut down the left and right side lines.

DEFENSIVE "T" FORMATION: Diagram 81. This formation is as strong defensively as is possible. Unless A can secure a back tap the formation implies that the opponents may have the ball providing they direct it to their back court. If A can secure a back tap of any kind it can be protected by B, D, and E.

HELD-BALL PLAYS: Held-ball plays will occur between 10 and 50 times during a game. When the contest is played between teams which use wide open scoring methods, held-ball plays will be infrequent. However, it is important that the ball be obtained as often as is possible. Possession is the thing and the play is secondary. All too often a player secures the tap in his front court but the ball is lost because of a misunderstood signal or because the ball was not protected by teammates. In the front court a

common error is to tap the ball forward into the very area in which the defense is massed. Another held-ball situation or loss of the ball usually results.

Probably no more than one formation should be practiced for front and back court use. Two or three plays for the front court can be developed but possession may be sufficient in the back court. (Quick-break methods may be used following possession of the ball in the back court.)

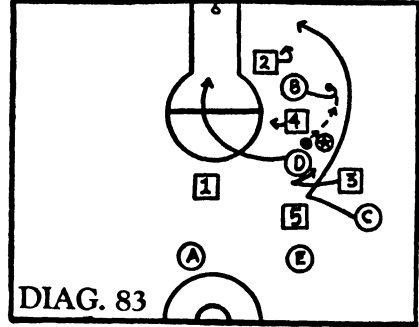
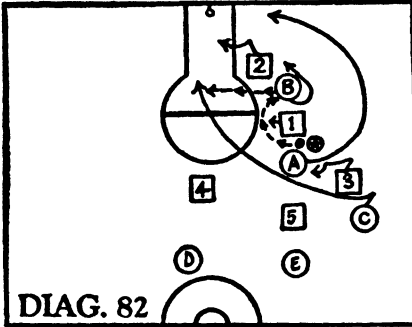

FRONT COURT HELD-BALL PLAY: Diagram 82. A One-One-Three formation has been set up by B, A (the jumper) and, from left to right in the rear court, D, E, and C. A forward tap can be attempted providing control is sure and the defensive players do not mass in front of the basket. The formation shown prohibits defensive massing to some extent. A tapped the ball to B and cut to the right around the official. C faked to the right and cut to the left through the free-throw circle where he received the ball from B. After the pass B pivoted to his left and followed-in. The rear court defense is set up by D and E.

FRONT COURT HELD-BALL PLAY: Diagram 83. The position replacement method is being used so that the formation set up may be maintained. Player A has been designated to replace the jumper's position. In this illustration D is the jumper and A has taken the rear court position usually occupied by D. D tapped the ball to B, and cut to the left. C started to the left but changed direction and cut to the right of B. The pass could be made to the player who succeeded in breaking loose. A and E set up the rear court defense.

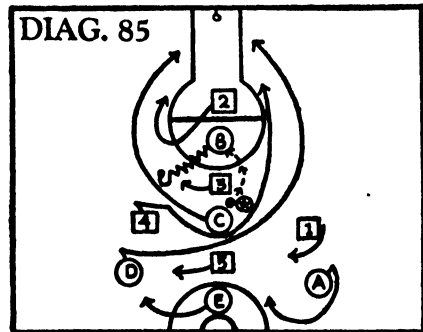
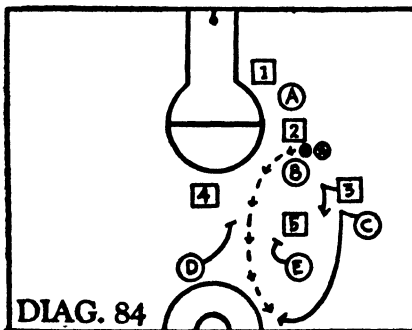

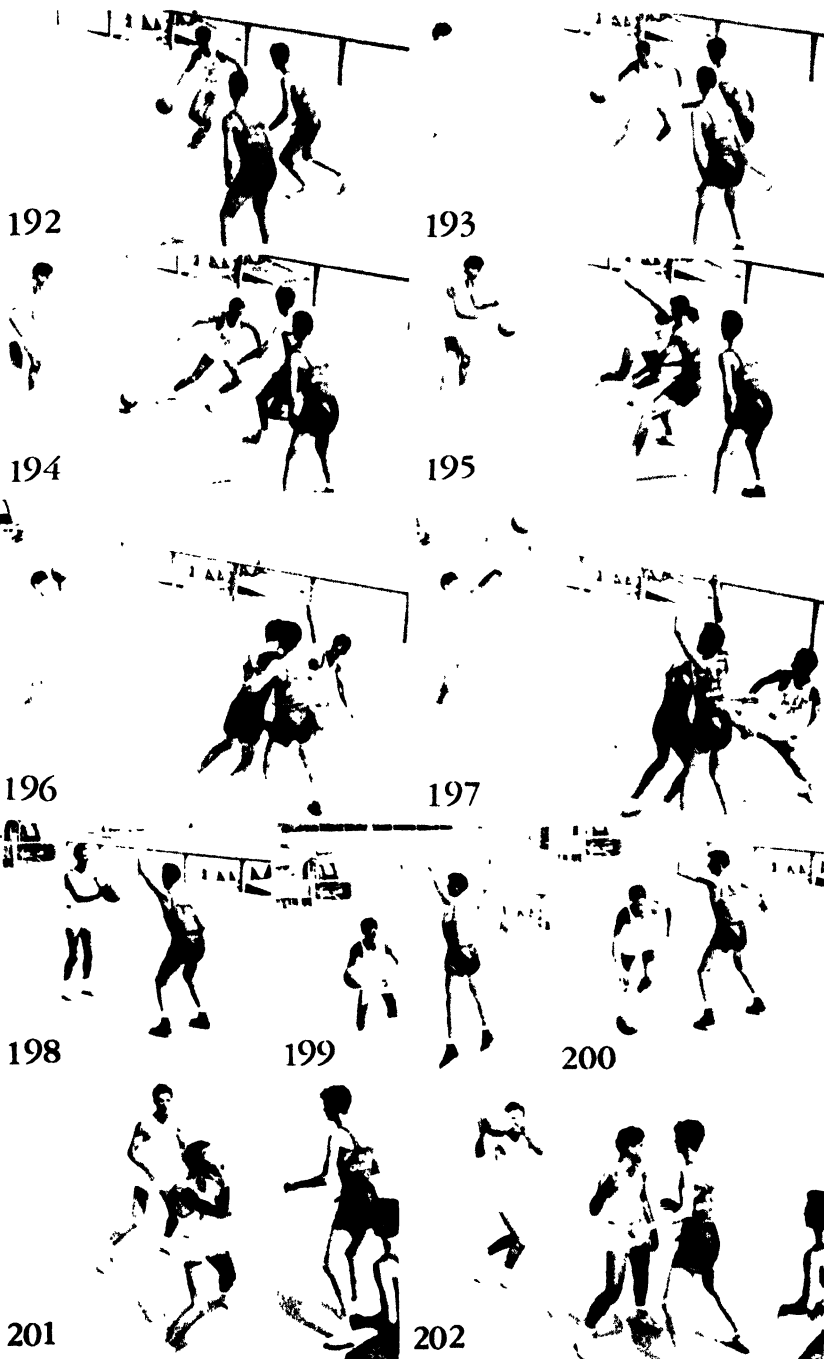

192—197. A give-and-go play with a change of direction is pictured. The guards seldom become so completely confused as is shown in the illustrations. (Anyway, the idea is good!)

198—200. The attacking player fakes a shot and then advances his right foot in driving toward the basket.

201—202. The over-shoulder pass sets up a good set-shot position. *Owen Reed*



203



204



205



206

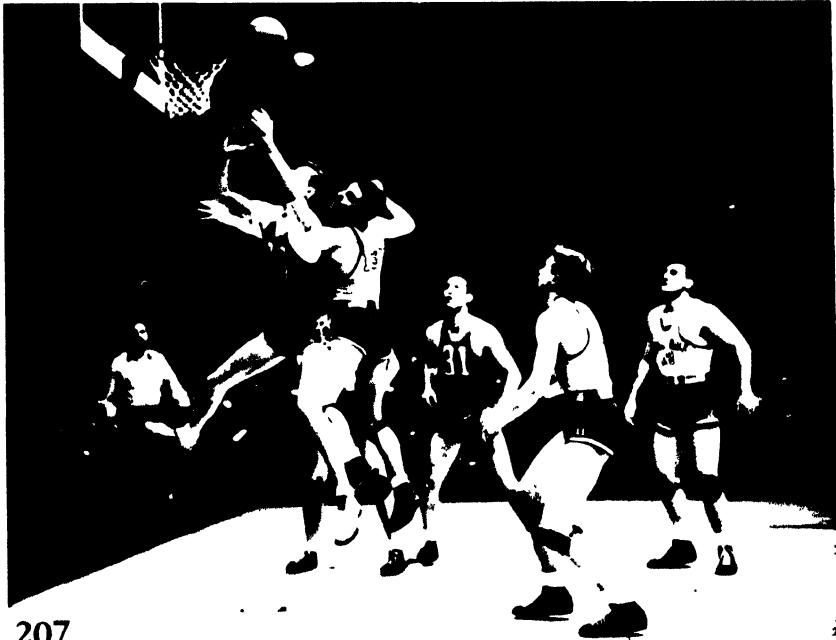

207

203. Starting the dribble with the outside foot.

204. Starting the dribble with the inside foot. (Cross-over.)

205—206. The player in white has stopped suddenly, changed direction, and used the cross-over with his left foot to cut to the basket. *Owen Reed* photos.

207. Henry Beenders of L.I.U. has timed his leap well and used the eagle spread.

FRONT COURT HELD-BALL PLAY: Diagram 84. B was engaged in the held-ball play and A replaced him in the front court. (This replacement method could not be used unless the tap was controlled and the man-to-man defense was employed. Since the tap advantage places the opponents on the defense they are forced to follow the attacking players.) In this illustration B preferred to insure possession of the ball so he used a deep back tap. His teammates, D and E, blocked opponents 4 and 5 away from the receiving point and it was easy for C to recover the ball after faking a cut toward the basket.

FRONT COURT HELD-BALL PLAY: Diagram 85. C is the jumper in this illustration and his usual place in the rear line has been taken by A. C tapped the ball to B who dribbled to his right and set up a post-block around which C could cut. Player D faked to the left and cut to the right. A and E protected the rear court.

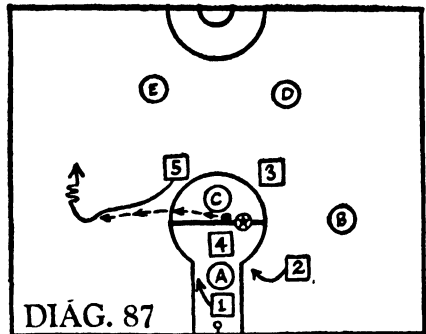
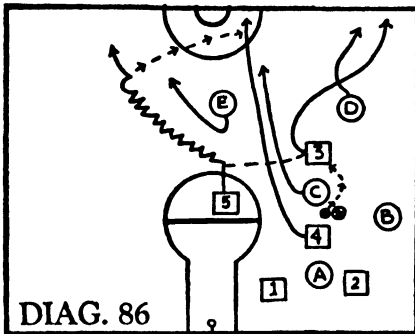

BACK COURT HELD-BALL PLAY: Diagram 86. A defensive formation has been set up in this instance because the opponents are close to their basket and a good shot may be obtained if they secure the ball. Although it is assumed that 4 will control the tap, his teammates 5, 1, and 2, have set up defensive positions to be on the safe side. Player 5 has floated back to the free-throw line and 2 has dropped back so that he and 1 practically double-team opponent A. The ball was tapped to 3 and 4 and 5 accompanied him in starting a quick-break attack.

BACK COURT HELD-BALL PLAY: Diagram 87. The held-ball situation occurred in the free-throw circle and 4 was again the jumper. His teammates 5, 3, and 2, have all floated back to mass in the basket area. Four managed to secure the tap and the ball was directed to 5.

Out-of-Bounds Plays

Out-of-bounds plays probably lead to more direct scores than those which result from all of the other auxiliary situations combined. This is due to the fact that the player out-of-bounds can usually make a good pass to a teammate in a pre-arranged play following planned and practiced maneuvers. The out-of-bounds passer is the player who determines the success of these plays. The setting up of a planned out-of-bounds formation should blend readily with the usual set attack. In most instances a pivot player will

be designated to take the ball out-of-bounds under the basket while a rear court teammate will be responsible for starting the plays from the side lines.

Regularly planned and practiced plays are important since they immediately place the opponents on the defense because of the speed and sureness with which they are executed. A most valuable point in connection with the play is possession of the ball. If a score does not result from the play, possession is in itself a reward. Most teams relax their defensive concentration momentarily when the ball is given to their opponents out-of-bounds. Quick surprise plays which do not require intricate maneuvers are possible when mixed in with the more formal attacks.

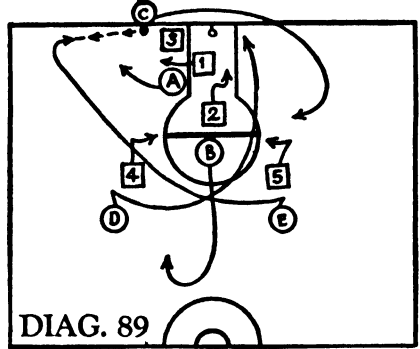
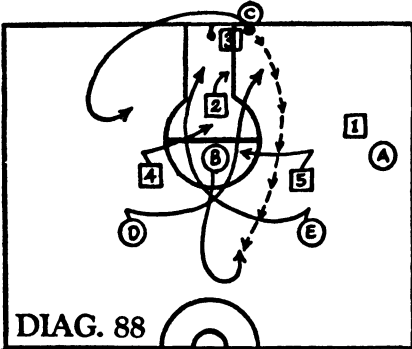

FRONT COURT OUT-OF-BOUNDS PLAY: Diagram 88. Player C has the ball out-of-bounds under the basket. Rear court players D and E split the post (B) and drive toward the basket. After they have cut by, B retreats toward the center line and receives a hard pass from C. He may attempt the best set-shot in the game (the direct center). Note that C has cut in the opposite direction from his pass and may be given a return pass if his opponent (3) is slow in following. (The offensive teammate on the free-throw line faces the basket and the ball may be passed to him should his opponent give him room by dropping back to switch.)

FRONT COURT OUT-OF-BOUNDS PLAY: Diagram 89. C again took the ball out-of-bounds and passed to E who, in company with D, had once more split the post.

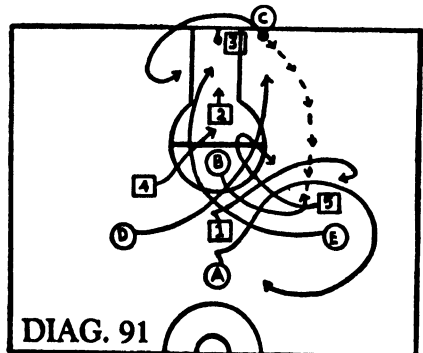
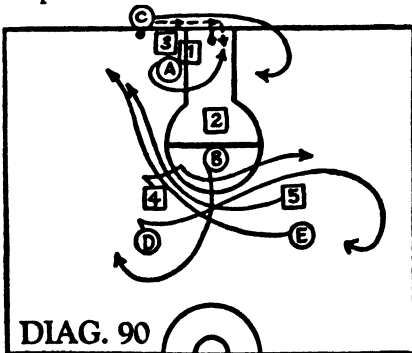

FRONT COURT OUT-OF-BOUNDS PLAY: Diagram 90. C picked up the ball and waited for D and E to split the post. A had assumed a position on the side

of the free-throw lane and suddenly pivoted under the basket. C passed the ball to A and cut across to the other side of the basket. This spin play is especially effective when the opponent guarding A plays him closely.

FRONT COURT OUT-OF-BOUNDS PLAY: Diagram 91. D and E split the post. As soon as they had cut by, B retreated to the right and was screened by A. C passed the ball to B who had time for a set-shot. (Note that C has cut in the opposite direction from his pass.)

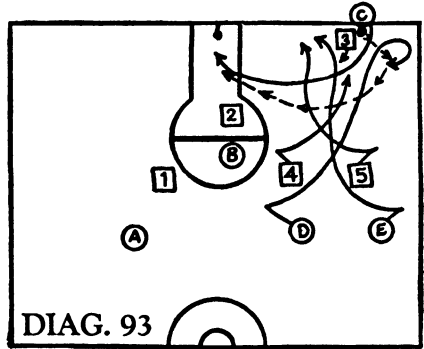
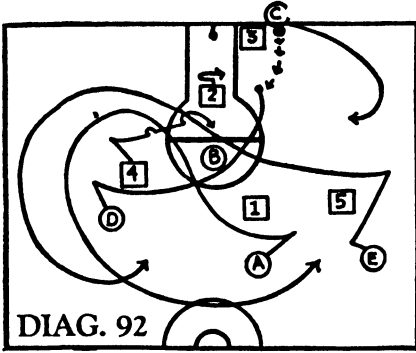

FRONT COURT OUT-OF-BOUNDS PLAY: Diagram 92. A and E screened on both sides of the post in order to set up a cutting play for D. D faked to the left and cut to the right of the post player just as soon as A and E split the post. C passed the ball to D near the basket and cut to the right corner. If 3 switches to D a quick return pass to C may enable him to get away a quick shot.

FRONT COURT OUT-OF-BOUNDS PLAY: Diagram 93. D and E combined to set up a play for C. They cut simultaneously and crossed paths. E stopped near the end line and C passed the ball to D in the corner. C then cut around E and his guard 5 and received a pass near the basket from D. If defensive 2 dropped back under the basket to stop the play, B could cut to the right for a pass from D.

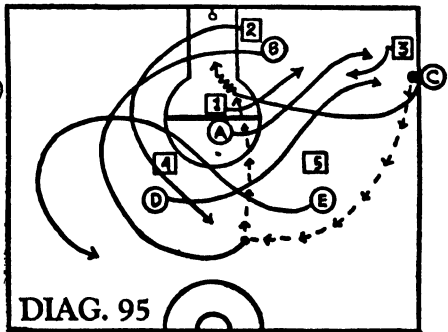
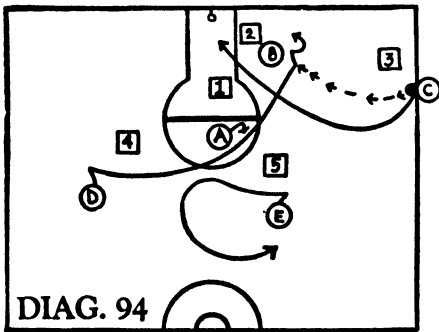

SIDE LINE OUT-OF-BOUNDS PLAY: Diagram 94. This play is safe and a shot always results but the speed of the cutter reduces its accuracy. D faked to the left and cut around the post player and then in front of B. C looped a lead pass to him in front of B and a good shot was possible. C followed the pass and cut in front of B.

SIDE COURT OUT-OF-BOUNDS PLAY: Diagram 95. Players A and D double-screened in front of defensive 3 immediately after B had started a cut toward the rear court. C passed the ball to B, sliced behind the screen, cut toward the free-throw lane, and received a return pass from B in front of the basket. If C does not break loose from his guard, B may attempt a set-shot.

Free-Throw Plays

Offensive free-throw plays can be expressed simply: "put the ball through the hoop." During half of the game a teammate will have an inside position on the right side of the basket and in the other half is entitled to the left inside position. Players should insist upon their proper positions since the ball will rebound on the right side more often than the left. Most coaches permit one tap following a missed offensive free-throw and then insist upon possession or a deep back slap.

Defensive free-throw plays are concerned with quick-break tactics. The ball must be started toward the basket quickly and an attempt made to outnumber the opponents in the long drive up the court. Most defensive recoveries are made from the inside position. It is unusual for a defensive player to recover the missed free-throw when he is in the outside position because he must concentrate upon the inside opponent who will attempt to make a tip-in shot.

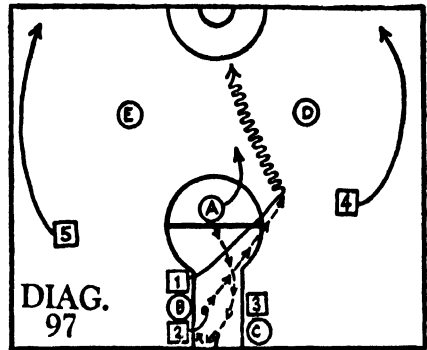
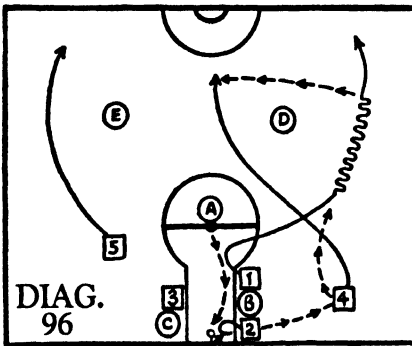

RECOVERY OF AN UNSUCCESSFUL FREE-THROW (INSIDE POSITION): Diagram 96. Opponent A missed the free-throw shot and the ball was tapped by 2 toward his teammate (4). One and 5 joined 4 in starting a fast drive toward their basket. If A is slow in retreating, the three attacking players may succeed in outnumbering D and E.

RECOVERY OF DEFENSIVE FREE-THROW (INSIDE POSITION): Diagram 97. Defensive player 2 recovered the ball and passed to 1 who cut across the free-throw circle and toward his basket. Teammates 5 and 4 joined 1 in attempting to beat A, D, and E to the basket.

CHAPTER VIII

MEETING THE MAN-TO-MAN VARIATIONS

THE USE OF goal-tenders, switching, pressing, and floating as special aids to the two basic defenses (man-to-man and zone) has been referred to. Undoubtedly one or all of these will be met at some time during the season. It behooves the coach to acquaint his players with each defensive principle and to stress the importance of certain methods that may prove effective in opposing them.

OPPOSING THE SCREEN-SWITCH: The screen-switch defense is most effective against a team which cuts laterally across the court. Because of this lateral movement, the defensive players can shift opponents with no difficulty and, in reality, find it necessary to move very little. For that reason the attack directed toward the screen-switch defense should be based upon change of direction, stops, starts, pivots, give-and-go tactics, the use of the offensive roll, trailer plays, and the post and pivot.

There seems to be a difference of opinion whether or not the front court should be kept open or congested with post and pivot players. When the screen-switch adopts the use of floating tactics, undoubtedly it is best to congest the front court by using moving or stationary post or pivot men. The ball can be passed to these men and they can then set up turn-around or legal block positions toward which defensive players can be maneuvered.

An attack which constantly drives toward the basket in straight lines, after changing direction, usually serves to confuse the defense and break a player free. The quick-break can be used to good advantage against the screen-switch defense. No matter what attack is used care must be exercised that defensive balance is maintained since the screen-switch also lends itself to effective use of the quick-break.

The passing technique in connection with give-and-go plays should consist of the usual snap, over-the-shoulder, back-bounce, and flip passes. When posts or pivots are used the baseball, two-hand overhead, bounce, and hook passes are important. Dribbling tactics by front court post or pivot players can be used to set up legal blocking positions around which the rear court men can cut. If the front court dribblers are good shots, the opponents guarding these players may fail to switch quickly. Cutting players may then break free. Set-shot possibilities depend upon the reverse roll, rear court circulation, and the use of clear-outs.

A number of two-man rear court plays which can be used against the screen-switch defense are illustrated in Diagrams 78 to 82, inclusive. The purpose of this series is to cause indecision or confusion on the part of defensive players 1 and 2 so that either A or B can break free. The third play of each series develops a trailer situation. In each of these trailer plays A cuts first but the timing is such that B follows immediately. A will usually provide a screen between B and his guard.

Series I: Diagram 98. These change of direction plays follow an inside screen by A between B and his defensive opponent (2). The plays work right or left and with or without the ball. As A screens in front of B he

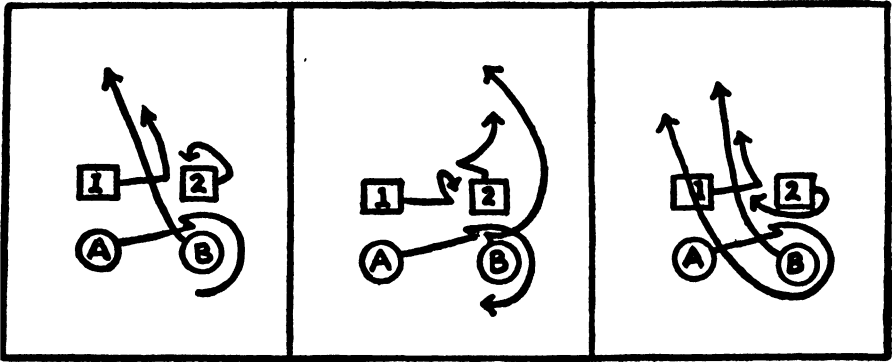

DIAG. 98

should hesitate slightly and feint a left or right cut toward the basket. As soon as A has passed in front of him and started to spin to the rear, B can cut in one of the various paths outlined in the series.

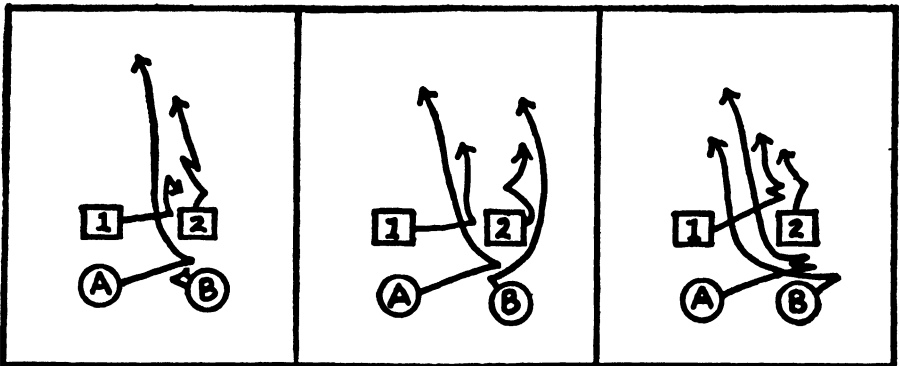

DIAG. 99

Series II: Diagram 99. In this series A moves in front of defensive 2 and then reverses direction by driving hard off his right foot and cutting for the basket. The defensive players usually anticipate a screen and prepare to shift opponents (2 switching to A and 1 concentrating on B). This change of direction by A is bound to cause some defensive confusion, providing he uses deception in altering his path. A change of pace should be used in this maneuver. B can add to the effectiveness of the play by feinting one direction before cutting the other. In developing the trailer situation (third play), A can feint several times while maneuvering between B and defensive opponent 2.

Series III: Diagram 100. Cutting to the rear of a teammate often draws a defensive player out of position and enables the cutter or his teammate to outmaneuver his guard. The second and third plays illustrate trailer situations which, in each case, are designed to provide a screen for B. In

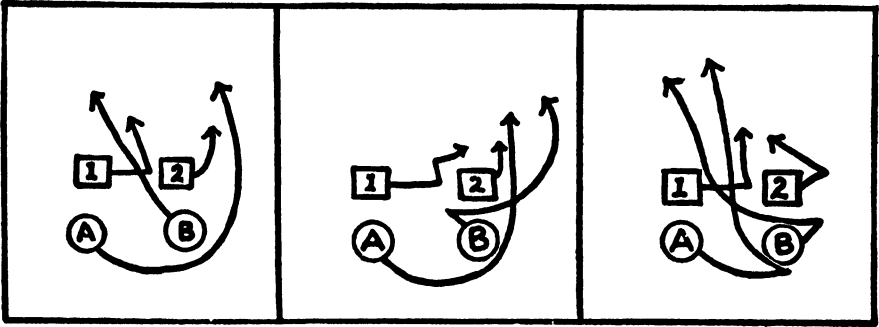

DIAG. 100

both instances A cuts first but B follows so closely that the action appears almost simultaneous.

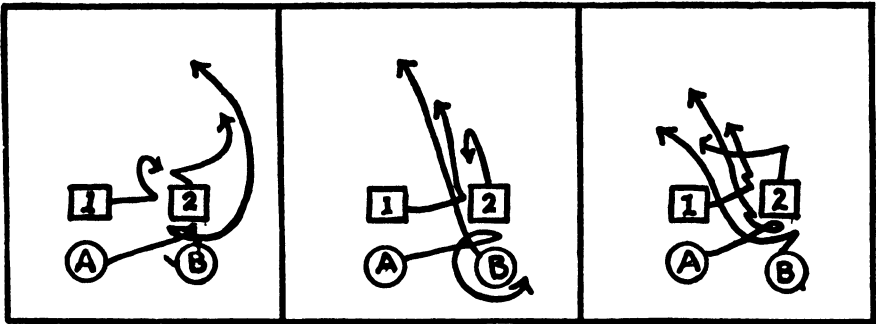

DIAG. 101

Series IV: Diagram 101. In moving in front of guard 2, A shifts right and left several times to disguise the actual direction he intends to drive. No move is made by B until after A cuts in the direction shown. B should feint right or left before actually cutting.

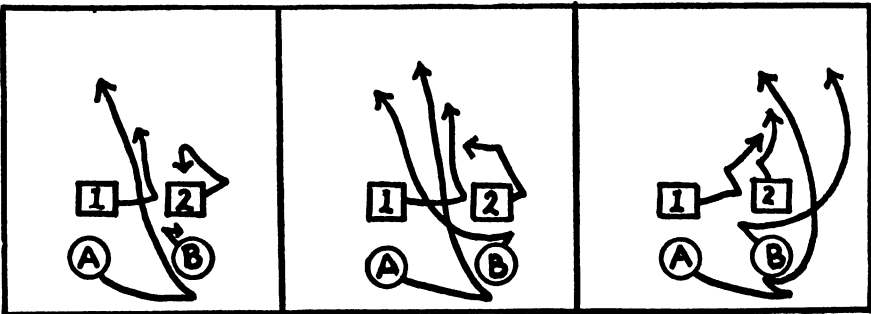

DIAG. 102

Series V: Diagram 102. Moving to the rear of his teammate, A reverses direction or feints to do so. B makes no move until A has actually cut. The

second and third plays provide trailer opportunities for B. B must time his drive so that he moves almost as quickly as A in driving toward the basket.

SINGLE AND DOUBLE POST ATTACKS: Single and double posts may be used effectively against the screen-switch defense. The post players can dribble in, maneuver for good feeding locations, or employ set positions around which teammates may cut in attempting to force their switching opponents into post-blocks. The turn-around series may be employed since it is directed toward switch situations. The use of dribbling by a single post player can be particularly effective providing he is also a dangerous scorer. The theory here is that the opponent guarding the post player will be kept so busy he may not switch quickly enough on plays which drive around the dribbler and toward the basket.

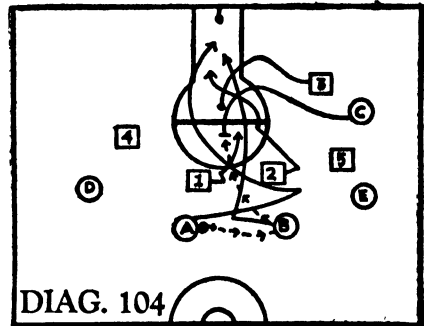
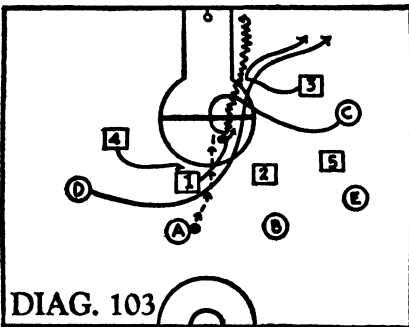

SINGLE POST DRIBBLE PLAY: Diagram 103. This attack resembles that in which the front court is kept open. The post player (C) cut from the right side of the court to the free-throw circle, received the ball from A, pivoted, and established a turn-around position. Player D screened between A and 1 and sliced as closely as possible to C. The defensive players shifted, 4 opposing A and 1 following D. Defensive player 3 saw the post-block and shifted to oppose D. As soon as C saw this shift or was contacted by opponent 1, he dribbled hard toward the basket. (This play can also be worked effectively without the turn-around. C may take a low feeding position, fake to give the ball to D, spin on his left foot, and dribble in to the basket.)

SPLIT THE POST: Diagram 104. Player C cut to a post position on the free-throw line where he received the ball from B. A screened between B and defensive 2, changed direction, and cut as shown. After A had reversed direction, B faked to his left and cut hard to the right side of the post. Player C is expected to pass the ball to the teammate who succeeds in breaking free from his guard. The change of direction principle, coupled with the possible confusion between 1 and 2 which may occur because of the failure to screen, may prove effective in countering the switch.

DOUBLE POST DRIBBLING PLAY: Diagram 105. A passed the ball to E and screened in front of defensive 5. E passed the ball to C, who dribbled to a post position on the free-throw line. As soon as C reached the free-throw line, player D faked to the left and cut to the right. Player E, on the other side of the court, faked to the right and followed his pass on the left side of the post. Because of the switching which is necessary between defensive players 1 and 4, D or E may be able to reach the basket unguarded.

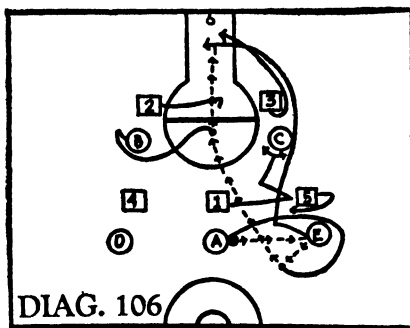
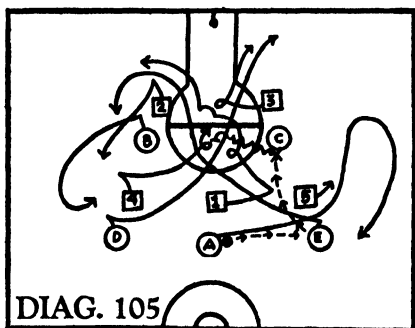

CLEAR-OUT AND POST-BLOCK: Diagram 106. A passed the ball to E, screened in front of 5, and reversed as shown. E returned the ball to A, faked to the left, and cut to the right of C. The post player on the left side of the court (B) broke to the free-throw line and received the ball from A. If defensive player 3 does not switch quickly, E may succeed in breaking free under the basket and receive a pass from B. In this play post player C is being used as a legal blocking post for cutting player E.

MEETING THE PRESSING DEFENSE: The pressing defense is an aggressive man-to-man type of play but may incorporate screen-switch principles in its application. The effectiveness of the pressing defense is limited to use in its front court and immediately after the opponents have secured the ball. Defensive balance is vital because the pressing defense is constantly seeking means to attack.

The pressing players pick up opponents following a score, successful and unsuccessful free-throws, held-balls, interceptions, and rebounds. Because of this fact it may be wise to develop and practice plays which can be used in the various situations. Certain formations can be devised to take care of the rebound and scoring plays as well as the held-ball situations.

The team which attempts to trade baskets with the pressing defense will find itself at a tremendous disadvantage because it is really playing the opponent's game. Withholding the ball from play, good passing, and maneuvering will suffice to provide good scoring opportunities. The use of feints, stops, turns, change of direction, change of pace, criss-crossing, and screening will usually serve to advance the ball to the front court. If the team possesses a good dribbler, it is wise to get the ball into his hands as quickly as possible in the back court. If he is clever he can defeat this defense practically single-handed. The pressing principles which are used by the defense require forward body balance. This unorthodox forward shift of body weight leaves the players susceptible to feints and clever maneuvering.

The pressing defense is anxious for an opponent to pivot in an effort to protect the ball because such a defensive move, making the offensive man "show," encourages blind or hope passes. For that reason one player should not dominate the ball (with the exception of the expert dribble). It should be kept moving from one player to another and be accompanied, if possible, by fakes and feints which are designed to keep the opponents off balance. In a great many instances, the pressing players will be outnumbered because

of their aggressive efforts to secure the ball. The attacking players in such a situation should not be so anxious to score that they forget to guard the pressing opponents who have been maneuvered out of position and left unguarded under their own basket.

Probably the most important plays which must be protected from the pressing defense are those which occur after a successful or unsuccessful shot attempt from the field, following a free-throw, a held-ball, and out-of-bounds situations in the back court.

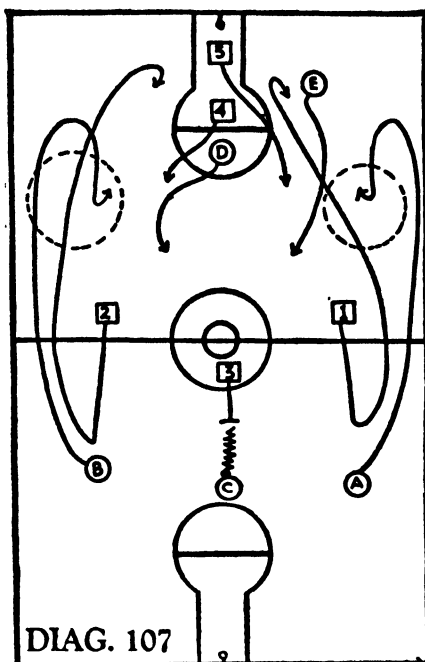

THE SEMI-PRESSING DEFENSE: Diagram 107. Not infrequently teams which use the pressing defense will retreat under their defensive basket and set up a three-two formation. The opponents may be lulled into a spirit of safety by this maneuver and advance slowly up the court without preparing to protect the ball. On a given signal, the three players on the front line of the defense charge their respective opponents and play them closely. This concerted advance frequently throws the attacking team off balance and bad passes result.

In the diagram player C is advancing up the court with the ball when he is pressed by defensive 3. Teammates A and B are also guarded closely. However, D and E are in excellent positions to break out to the ball. Their opponents will no doubt follow them. The broken lines bounding the circles on the sides of the court are excellent areas for set-shots. When the ball has been advanced through the medium of the pivot players (D and E), the front line defensive players usually retreat under the basket for safety purposes allowing the wing attacking players (A and B) time for a set-shot if they will stop in these areas.

THE SINGLE SCREEN: Diagram 108. This formation and the single screen

between D and E may be used to meet the pressing defense following a successful goal or free-throw by opponents. One player is usually designated to take the ball out-of-bounds following a score. He should be the best "pitcher" on the team. D and E screen across in front of the basket and C passes the ball to the one who is farthest removed from his guard. If D and/or E are not able to break free, the pass can be made to one of the second line players. In the set-up being discussed, C would probably try to pass to B if a pass to D or E was impossible. A, on the other side of the court, would be the third choice for the pass.

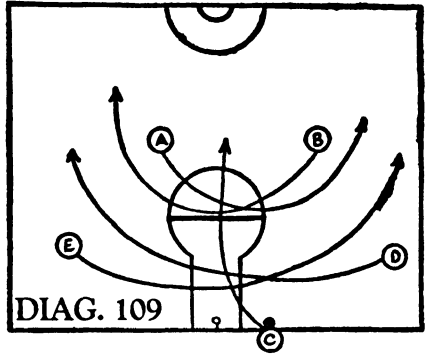
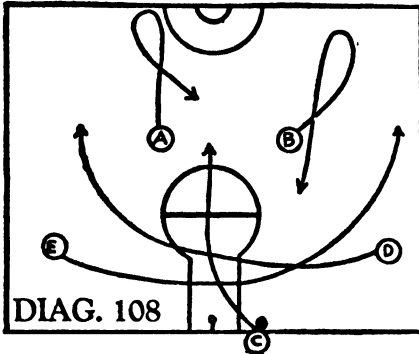

THE DOUBLE SCREEN: Diagram 109. In this illustration C again has the ball out-of-bounds under the basket and D and E screen as before. A and B also screen in the rear court to afford C third and fourth alternates should a pass to D or E be impossible. After the first pass the ball may be advanced by a number of means—dribbling, passing, the use of fishhooks, and pivots.

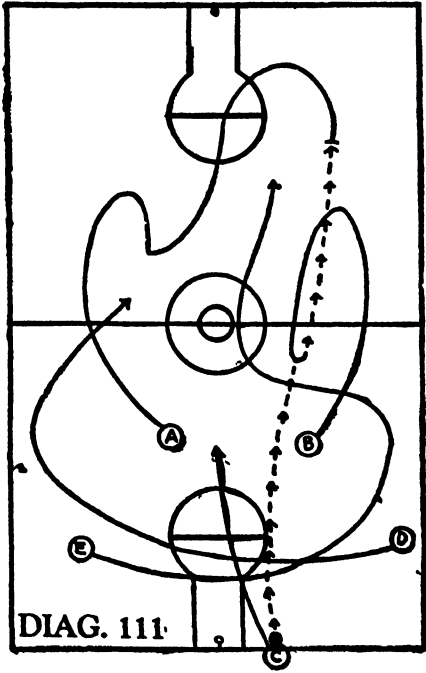
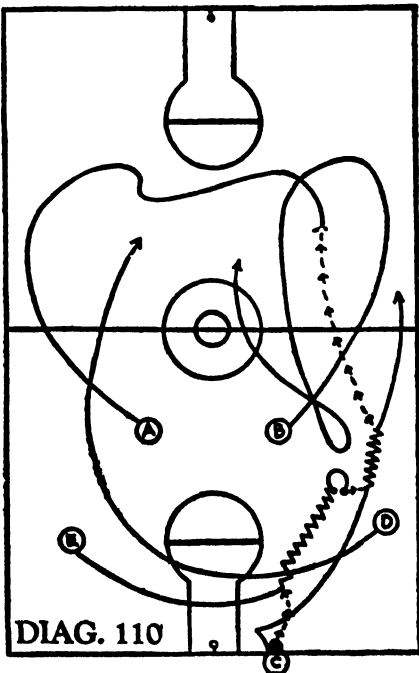

SINGLE SCREEN PLAY: Diagram 110. As C picked up the ball out-of-bounds, D and E screened as shown. E seemed to have the best position for the pass and after receiving the ball dribbled hard up the right side of the court. When stopped by an opponent, he pivoted and returned the ball to C who had followed his pass. B started down the court and reversed direction but was too closely played for the pass. C passed to A. When executed with dash and confidence, this is an effective means of reaching the front court without disaster.

SINGLE SCREEN LONG PASS: Diagram 111. D and E screened as before but were too closely played by opponents. B cut toward his basket to throw his respective opponent off balance and fishhooked back to receive a long pass near the center of the court. If the ball is met high in the air there will be little danger of an interception. B's teammate A had also started back but when he saw that B was in a good position to receive the ball continued beyond the free-throw line before reversing to receive a pass from B. After the ball has arrived in the front court, pressing methods merely represent close man-to-man guarding.

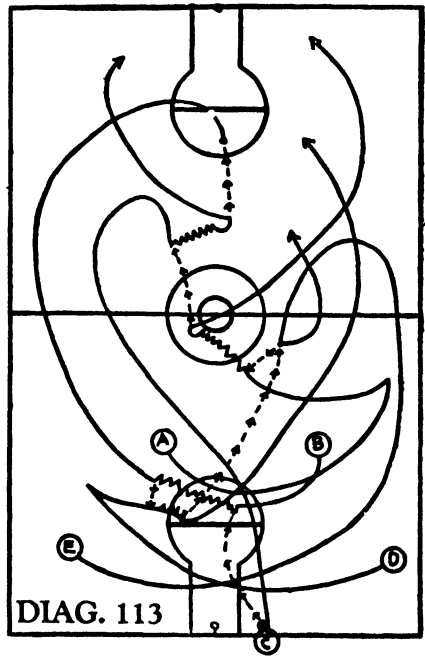
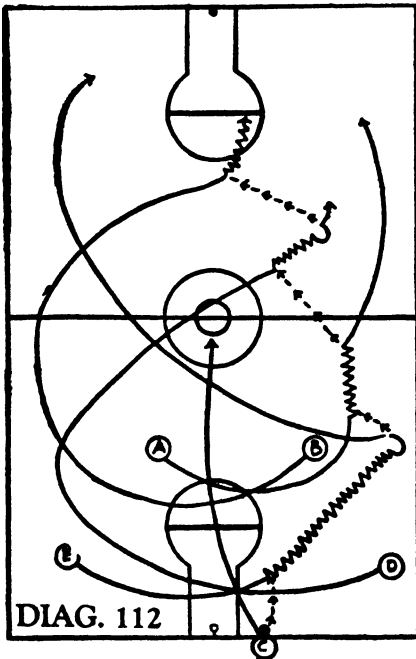

DOUBLE SCREEN FRONT LINE PASS: Diagram 112. C passed the ball to E in this double screen formation. E dribbled hard until checked by an opponent and then passed to A, who had been screened by B. A continued the dribble and forwarded the ball to D, who had cut to the opposite side of the court and was in a good receiving position for the pass. D dribbled a short distance and then passed the ball forward to B in the vicinity of the free-throw circle.

DOUBLE SCREEN SECOND LINE PASS: Diagram 113. D and E were closely played and C passed the ball to B who had been screened by A. B dribbled

a short distance to the left and then passed to D who had reversed direction. Dribbling a short distance, D passed the ball forward to E who set up a post and passed to A. A dribbled and then passed to C, who had followed the ball and fishhooked after passing the ten-second line. C also dribbled a short distance and then forwarded the ball to B in the outer half of the free-throw circle.

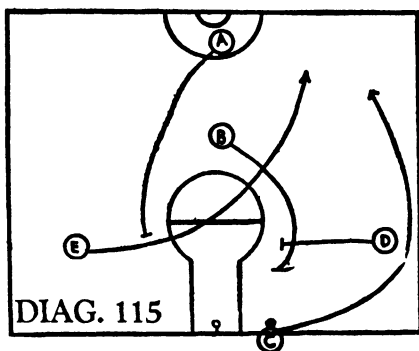
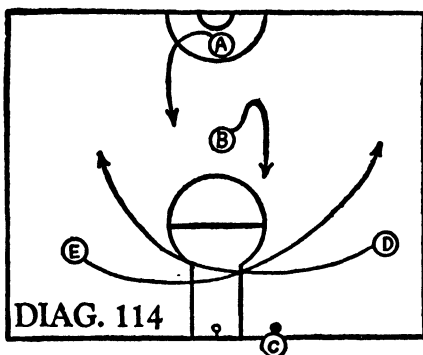

THREE-IN-LINE WITH A SINGLE SCREEN: Diagram 114. This formation is designed to forward the ball to B or A (probably in the best position to protect the first pass). However, should D and E succeed in breaking away from their respective opponents, one or the other would be given the ball.

THREE-IN-LINE WITH POST-BLOCKS: Diagram 115. This formation is effective on either side of the basket. When used on the left the screening and positions of the post-blocks would be reversed. The set-up is designed to protect the short pass to B or a cross-the-lane pass to E, breaking up the court. On the right side of the basket, player D breaks toward E as if to establish a screen. However, he stops upon reaching the free-throw lane, faces C, and sets up a post-block around which B can drive toward the ball. On the other side of the lane, the third player in line (A) breaks to a post-block position designed to enable E to cut away from the ball.

THREE-IN-LINE SINGLE SCREEN PLAY: Diagram 116. The screen players D and E have been played closely and it is difficult to pass them the ball. Player B started a fishhook at the same time D and E screened across the court. C passed the ball to B, who received it high in the air and gave it to E, who had cut close to him. A fishhooked down the court and received a long pass from E in the front court. C followed the ball in a direct line up the court, received the ball from A, and passed it to B near the free-throw line. In this formation it will be noticed that the ball followed a straight line up the court. The dribble was not used.

THREE-IN-LINE WITH POST-BLOCK PLAY: Diagram 117. Player D starts this play by driving toward the free-throw lane and setting up a post-block, facing C out-of-bounds. B drives close to D, receives the ball, and passes to E. E had cut in front of A on the left side of the court and the ball was passed to him near the free-throw line. After making the first pass C cut up the right side line and received the ball from E. He then passed to D, who had used a loop cut to arrive in the front court. By this time A had

completed his circle and was able to receive the ball and forward it to E near the free-throw line.

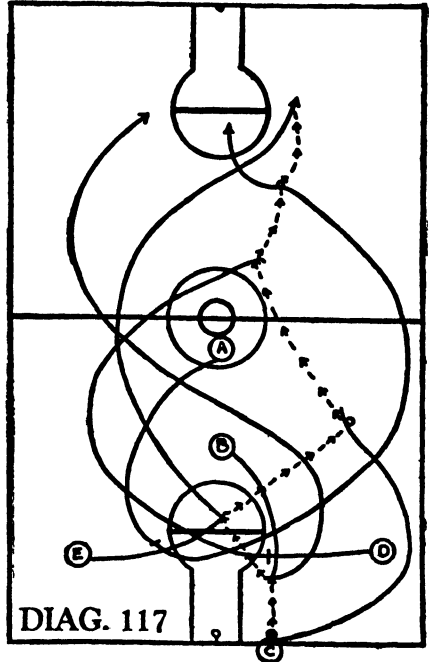
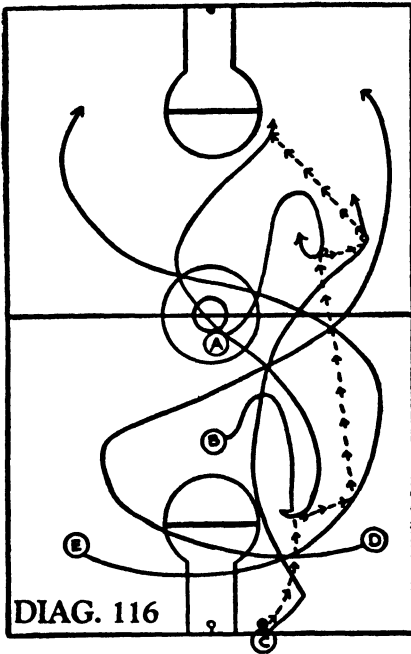

FISHHOOKS FOLLOWING A REBOUND: Diagram 118. The rebound was secured by C, who dribbled to the side and passed the ball to A. D and E, who were closest to their basket, hurried up the court prepared to fishhook. A dribbled a short distance and then forwarded the ball to E, who passed it to D. In this case the ball followed a fairly straight line up the court after it had been recovered from the backboard by C. Fishhooks are particularly efficient because the players drive toward the passer and the ball is caught high in the air, eliminating interception opportunities.

SCREENING FOLLOWING A REBOUND: Diagram 119. Rebound-guard C recovered the ball, dribbled a short distance, and then passed ahead to E. The play then continued as shown. Screening against the pressing defense usually requires the use of the dribble. The path of the ball is not as direct as when the fishhook is used but if there are one or two clever dribblers available it is probably as efficient.

A HELD-BALL PLAY: Diagram 120. The ball is being tossed up between A and his pressing opponent 1. It must be kept in mind that the pressing defense is offense-minded, whether or not they control the tap. For that reason it is wise to use a defensive formation and protect the ball when the tap is controlled rather than try to score by means of an attacking set-up. A tapped the ball in the direction of the free-throw line. His teammates, C and D, blocked out so that E could recover the ball. After a short dribble E forwarded the ball to B, who dribbled and then passed the ball forward to the jumper (A). The other players cut as shown. After the back tap

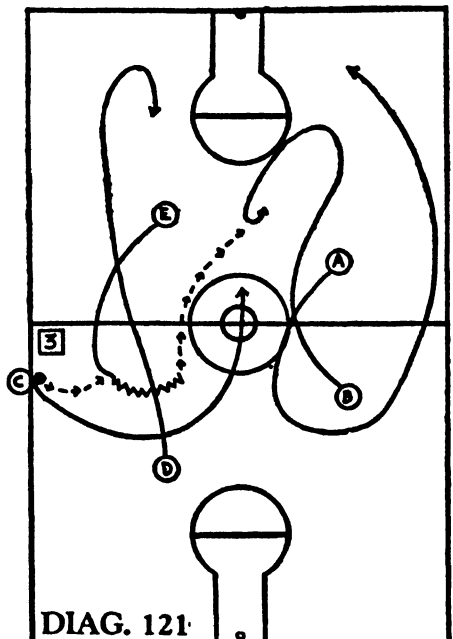
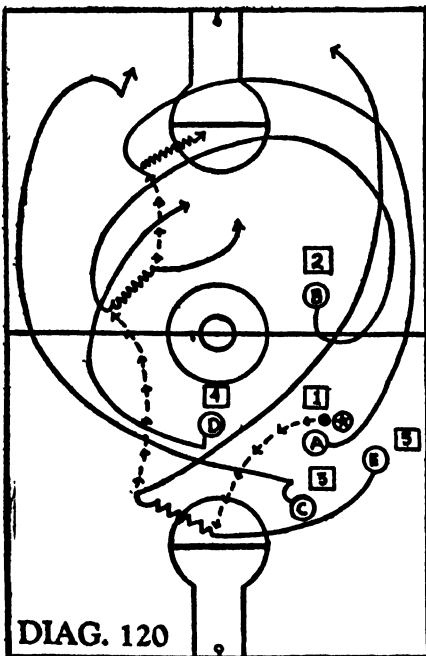
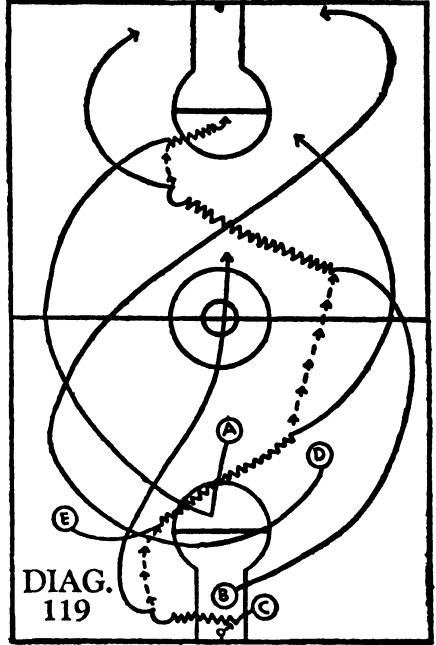
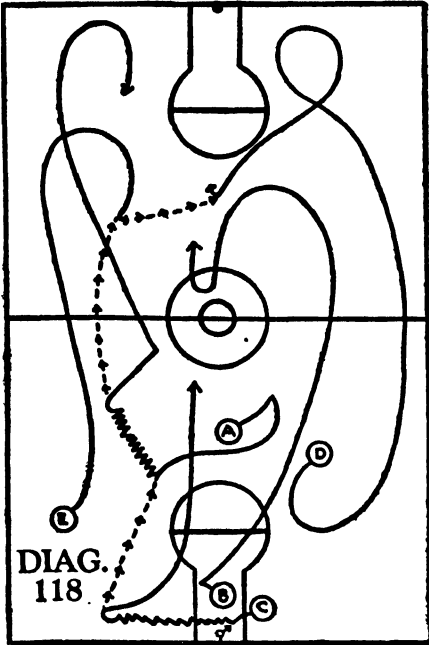

from the held-ball situation, the progress of the ball has been in a fairly straight line, although interspersed with dribbling.

OUT-OF-BOUNDS PLAY: Diagram 121. C has the ball out-of-bounds on the side of the court and is being played closely by defensive player 3. The double screen formation has been set up facing the side line. D screens ahead for E, who receives the ball, and after a short dribble passes up court to E, who receives the ball, and after a short dribble passes up court to B, who has fishhooked after being screened by A. On arrival in the front court the regular offensive style can begin.

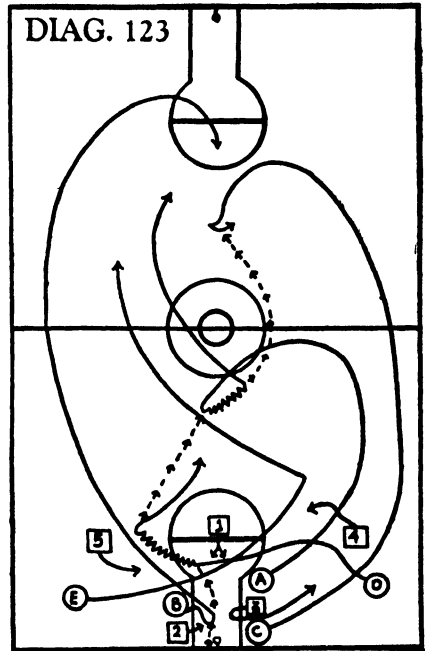
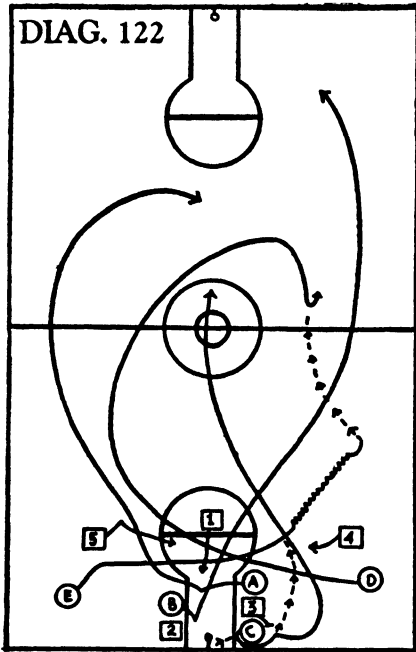

UNSUCCESSFUL FREE-THROW RECOVERY, RIGHT SIDE: Diagram 122. When a free-throw attempt has been successful, the attack which is used following a goal from the field can be employed. However, when it is unsuccessful, the use of the screen may be important in advancing the ball. The ball was recovered by C, who turned to his left but found himself closely played by opponent 3. Player E on the left side of the court cut across court and after being screened by D received the ball from C. He dribbled a short distance and then passed the ball to D in the front court.

UNSUCCESSFUL FREE-THROW RECOVERY, LEFT SIDE: Diagram 123. Player B recovered the ball and passed it to D, who had been screened by E. After a short dribble, D passed the ball to his teammate A, who had fishhooked back and eluded his guard. A dribbled a short distance up the court and then passed to C, who had also fishhooked to a position in the front court.

FLOATING: When a defensive player floats away from his opponent the implication is that the competitor is not moving. The best possible way to eliminate floating is for the attacking player opposing the floater to cut hard and fast toward his basket. Unless a zone or screen-switch defense is



208



209



210



211



212



213

208—213. Fred Lewis, L.I.U. sharpshooter, demonstrates the overhand free-throw. Although the feet do not leave the ground as in the set-shot from the field, body action is generated into the shot by the bend of the knees and the snap from the heels to the toes which occurs just previous to the release of the ball. All L.I.U. players use the overhand free-throw. *Owen Reed photos.*

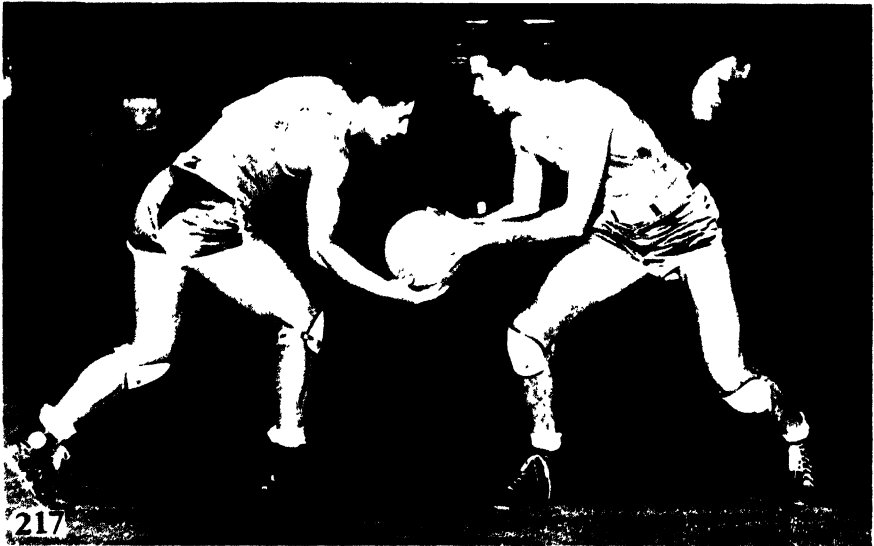

214. Coach Harold Olsen and his Ohio State players celebrate a victory.
215. Richard Ahrens, 6' 11" center, reaches up and catches the ball with one hand following a shot by an opponent. Dick could knock out any shot.
216. Ahrens and his high school coach, Cliff Wells, of Oil City, Pa.
217. Ossie Sheckman and Simon Lobello, L.I.U. turn-around experts.

Ed Wergeles photo.

being used, the defensive player will be forced to follow his respective opponent.

The use of post or pivot blocks is particularly effective against an opponent who floats. In a great many instances he is watching the ball and not concentrating upon an opponent who may move into a position back of him. A hard cut by the offensive player may then force a switch or run the floater into a block. The use of turn-around, post, and pivot plays, is important in meeting vertical floating. When the opponents float laterally, hard cutting paths directed toward whatever congestion may exist on the other side of the court are probably best.

Set-shot opportunities can be developed by shifting a post or pivot-block teammate in front of the floater. When an assigned floater is being used, the offense should be quick to take advantage of the situation. Assigned floaters are usually opposed to a player who does not possess a good long shot or who seldom cuts toward the basket. A change in the tactics of this player is necessary. It may be possible to station a strong cutter or good shot in the rear court so that he can take advantage of the lax guarding of this particular opponent.

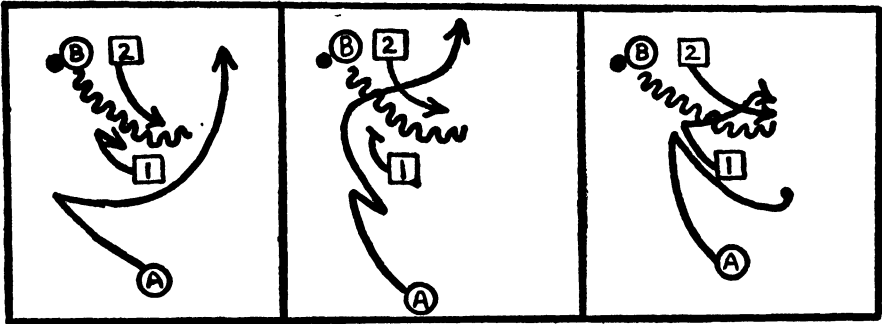

DIAG. 124

PLAYS AGAINST VERTICAL FLOATING. SERIES I: Diagram 124. In this series defensive player 1 is floating away from opponent A. Since the ball is behind 1, A's teammate (B) can aid in blocking the floater (1). B dribbles across the court and, at the same time, A cuts to the left, changes direction, and drives toward the basket. The efficiency of the play depends upon the indecision of defensive player 2 with respect to leaving a "live" dribbler (B) and switching to an opponent without the ball (A).

The second screen play involves a faked change of direction designed to cause defensive confusion between 2 and 1. The third play of this series may be used by A to secure a good set-shot providing his opponent (1) cuts behind player B and defensive 2.

PLAYS AGAINST LATERAL FLOATING. SERIES II: Diagram 125. In this series defensive player 1 has floated laterally across the court. Player B can assist A in breaking free by driving across court toward his teammate. In the first play he cuts toward defensive player 1 and A uses this screen as a means of eluding 1.

In the second play B screened in front of defensive 1. A trailer situation can be developed if A will start to the left and change direction to the

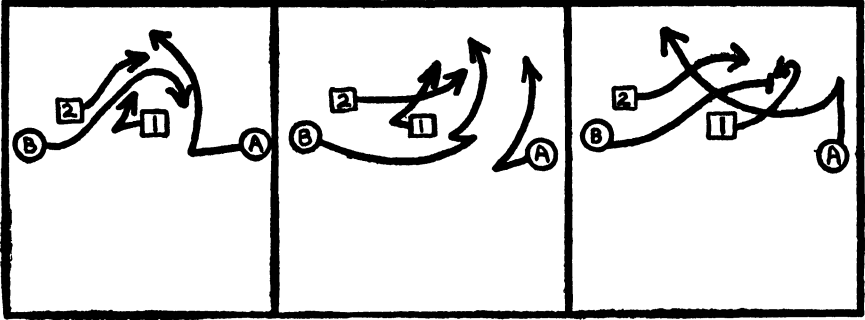

DIAG. 125

right. The use of a post-block can assist A in driving toward the basket, providing he uses a change of direction and times his cut so that his teammate B is not in motion when he drives toward the basket. Since there is a danger that B may be penalized for blocking unless he observes the three-foot restriction and maintains a stationary position behind defensive 1, A should not cut too quickly. (Third play.)

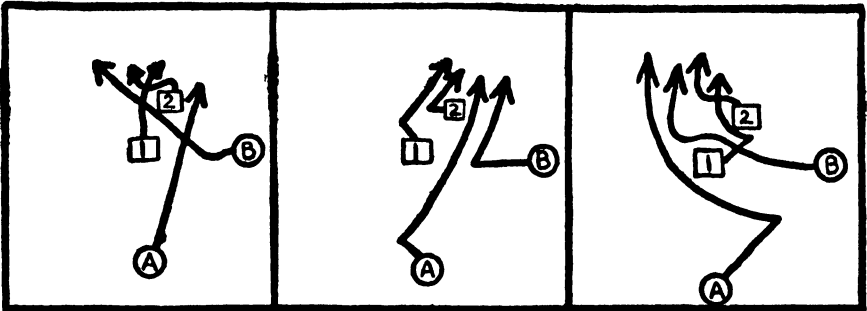

DIAG. 126

PLAYS AGAINST TEAM FLOATING. SERIES III: Diagram 126. In this series two attacking players are guarded by opponents 1 and 2, who are using floating tactics. Defensive player 1 is floating vertically away from A while 2 is moving laterally from B. Player A inaugurates the play by screening between B and his opponent (2). B must time his cut to the left so that he drives close behind A.

In the second play a trailer situation can be developed following a change of direction. Just as A screens in front of 2, B starts to the left and then reverses to the right. In the third set of plays, B is able to provide a trailer play situation for A. Players A and B start at the same time. B screens between the defensive players and A changes direction so that he can utilize a screen composed of B and 2 between himself and his defensive opponent (1).

PART IV. OFFENSIVE FORMATIONS AND PLAYS.

CHAPTER IX

SINGLE AND DOUBLE POST ATTACKS

POST PLAYER: A post player may be defined as one who stations himself on or near the free-throw line with his back to the basket and who is used by teammates as a receiver and passing medium for cutting plays. He may utilize his position to score but in most cases serves as a receiving, feeding, and blocking post for teammates. The post position, then, may be regarded as a medium for feeding and a block around which players can cut to the basket (the use of a post is important in the delayed attacks which are directed against the zone defenses).

MOVING POST PLAYERS: A number of Western teams have developed the use of the single or double post attack wherein the post players are constantly moving from the corners or sides of the court toward the free-throw line. While teammates maneuver in the rear court, the post player starts the attack by breaking out to the ball and establishing a position around which teammates can cut. In some cases dribbling is permitted and the post player, after receiving the ball, drives in to the basket for a score or moves to a particular position on the floor where certain plays function best.

PASSES TO POST PLAYERS: The rear court players use a great variety of passes to feed the ball to the post player. The two-hand overhead, bounce, hook, and baseball passes are most consistently used.

PASSES USED BY THE POST PLAYER: After receiving the ball the post player is valueless unless he can score or feed the ball efficiently to his cutting teammates. His feeding passes will depend greatly upon the position he assumes when receiving the ball and the guarding to which he is subjected. The use of the two-hand over-the-shoulder, two-hand overhead, back bounce, baseball, and the various underhand passes which are accompanied by a pivot on one foot are necessary in good post feeding. When the post player assumes a crouched position and handles the ball close to the floor, the use of flip and underhand passes which are protected by a long step with the opposite foot will prove efficient.

SINGLE POST SCORING: Scoring by the single post player will depend upon the defensive ability of his respective opponent. If attacking players cut around the post with great speed, there is no doubt that the opponent guarding the post player will be forced into a number of switching situations. Switching moves by his assigned guard permit the post player use of the

one- or two-hand shot. However, if the guard does not switch, the scoring will be effective in proportion to the post player's feeding ability.

Scoring opportunities may be secured by faking a pass to a cutting teammate and dribbling toward the basket, or through the use of the turn-around series. After the ball has been fed to a cutting teammate, the post player can retreat a step or two and, should his respective opponent switch to the cutting player, receive a quick return pass. These return pass plays occur frequently because of defensive confusion in switching situations and provide opportunities for quick shots.

DOUBLE POST SCORING: When two post players are used (one on each side of the court opposite the free-throw line), most scoring results from a cutting or scissors attack directed toward the basket through the center of the court. The free-throw and under-basket areas are kept open so that the rear court players may use screening and scissors methods to drive under the basket for a pass. Cutting plays are designed to free either or both of the post players so that they may also take part in the under-basket scoring. Their position near the free-throw line enables them to follow-in a great number of shots and this is often an important part of the double post scoring attack.

THE FOLLOW-IN: Because of their extended position from the basket, the post players must learn to spin quickly and maneuver in getting into position to attempt the recovery of their own or teammates' shots. The distance from the basket often aids in follow-in work because the flight of the ball can be gauged accurately and the probable direction of the rebound determined.

Single Post Attack

REAR COURT PLAYERS: The selection of a single post attack as the basic offense will depend upon the abilities of the players who make up the squad. It is assumed that there will be a number of rear court players who understand give-and-go and screening tactics thoroughly. These players should be good dribblers and fleet of foot. (See Chapter VI.)

THE POST PLAYER: A tall and strong player should be available who can be used as a moving or stationary post feeder. He should have good jumping ability and be able to handle passes with dexterity. If the post position is used to provide a block around which the rear court players can drive to the basket (depending upon one another for feeding duties in the give-and-go and screening attack), the passing ability of the post player is not so important. When the post player is being used as a post-block he usually maintains a stationary position facing the basket. When his assigned opponent switches, the post player is expected to follow-in for scoring attempts and rebounds. When the attack depends upon the post player for feeding and scoring, he must blend into the general offensive circulation.

STYLE OF PLAY: Ball-ahead-of-the-man or man-ahead-of-the-ball will determine how the post player is to be used. Man-ahead-of-the-ball implies that the rear court players will use the give-and-go attack exclusively for the development of plays. However, an efficient feeding method may be developed whereby the post player assumes a position near the side line and

passes to teammates cutting from the other side of the court. (Scissors plays are important in this particular style.)

Ball-ahead-of-the-man means that the post player will maneuver in the front court until the ball can be passed to him. Thereafter screening and maneuvering in the rear court will be used to break a player loose near or under the basket for a return pass. In this style of play the best results will probably be obtained if the post player will move laterally across the court, prepared to drive out to meet a pass from the rear court players. This lateral movement will aid in setting up offensive triangles which can be used as the basis for cutting plays.

DEFENSIVE BALANCE: The single post attack provides excellent defensive balance because there are generally two of the rear court players near the center of the court. (Cutting is assumed to be limited to two players at a time. More than this number will congest the scoring area.) The position of the post player in the vicinity of the free-throw line is such that he will be able to drop back in the rear court when the quarterback is left alone.

CIRCULATION: Most post attacks require that the player who starts the play follow the pass. The path may comprehend a screen or change of direction preceding a dash for the basket. The four rear court players weave continuously and attempt to cause confusion on the part of their defensive opponents so that a teammate may cut around the post-block and receive a pass from the rear court.

When the ball is in the possession of the post player, it will be necessary for two or three of the rear court men to maneuver so that one of their number can take advantage of the poor defensive position of an opponent. When long cuts are made toward the basket, players retreat up the sides of the court. Not more than two men should cut at one time.

MOVING TURN-AROUND POSTS: The turn-around series blends in well with the single post attack. The effectiveness of turn-around plays depends upon the passing and set-shot abilities of the post player. He starts the series by turning as soon as he receives the ball and faces the basket. In making the turn-around he should sweep the ball overhead with two hands and hold it there until a teammate breaks around him and drives toward the basket.

The team use of the turn-around series requires that the player who throws the ball to the post player follow the pass. His teammate in the cutting play will be the player who had passed to him just before he forwarded the ball to the post.

The turn-around play can start from any position on the court, entirely depending upon the post player. He must break to the ball and decide whether or not his position is a good one and the situation is such that the play can be effected. As a general rule the player who first drives around the post reverses back under the basket if he does not receive the ball on the initial cut. He is expected to follow-in all shots. The second cutter in the play drives toward the side line but holds himself ready to circle back for a pass. He also is expected to follow-in.

STATIONARY FEEDING AND BLOCKING POST: When a team possesses a strong ball handler it may not be necessary to employ moving tactics to protect the ball. Moving posts are used to guard against interception. However, a great number of post players possess the ability to assume a set position and

because of their height, weight, or ball handling ability protect the ball.

The stationary post may be established in the outer half of the free-throw circle or on the sides of the court and can be used as a feeding medium or as a legal block. When used for blocking purposes only, the post player usually passes the ball until a teammate attempts a shot, whereupon he follows-in. Split-the-post plays are most effective when the post player stations himself on the free-throw line.

When the post player is situated on the side of the court, screening, slicing, and scissors plays will be most effective. The position of the post player on the side of the court will enable him to protect the ball and allow his rear court teammates enough room to maneuver in their attempts to free one another for a cut toward the basket. The post player may also take part in the team screening, starting from a set position on the side of the court and driving toward the free-throw line to establish a post-block. The post player must be careful to observe the three-foot and non-motion rule recommendation in this screen. Quite often a double screen can be used. The post player and a teammate screen simultaneously across the court so that a teammate on the other side of the floor can cut around them and outrun his guard to the basket. The feeding for this type of play must come from a rear court player.

Dribbling may be incorporated in all of the attacks which have been discussed. If the post player is clever in dribbling and handling the ball, his individual opponent may find it too dangerous to switch to help a teammate who is being forced into a block.

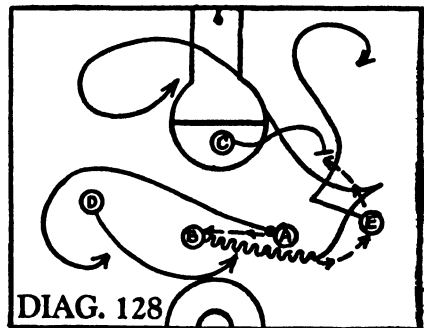
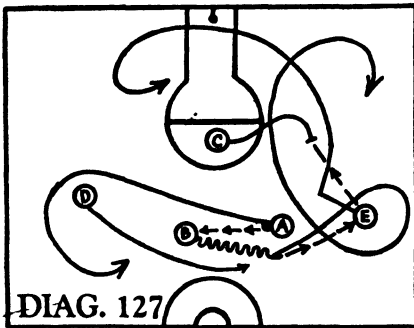

Turn-Around Post Series

Diagram 127. While A, B, D, and E maneuver in the rear court, C, the post player, is watching for a good opportunity to break to the ball and set up a turn-around play. Player A passed the ball to B and screened as shown. After receiving the ball, B dribbled a short distance, passed to E, screened between E and his guard, and cut on the left side of the turn-around player. E started the play by passing to C. As soon as C received the ball, he pivoted and watched for E to cut by him. E tried to trap his guard by cutting to the left, changing direction, and driving around the right side of C. If the opponent guarding C does not switch, the ball may be passed to E for a

lay-up shot. If a switch is made, C will have the option of dribbling toward the basket, attempting a set-shot, or passing to B. The timing of the play requires that E drive past C immediately after the pass is made while B should delay until after the turn-around options between C and E have been attempted. B, C, and E are expected to follow-in all shots resulting from this play.

Diagram 128. This play is similar to that illustrated in Diagram 127. A change of direction by B causes him to be the first man to cut around C. This means that he will be expected to circle back toward the basket if he does not receive the first pass. After receiving the ball from B, E passed to C, started to the left, and changed direction to the right. If it is possible to use one of the turn-around options, the play will be attempted. If not, E will circle back in the right corner, prepared to follow-in if a shot occurs on the play.

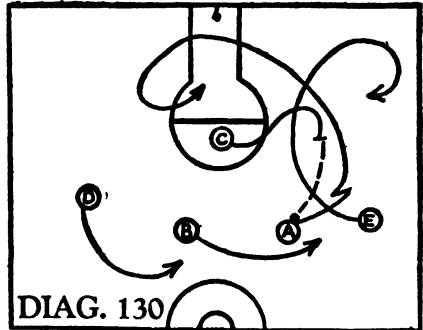
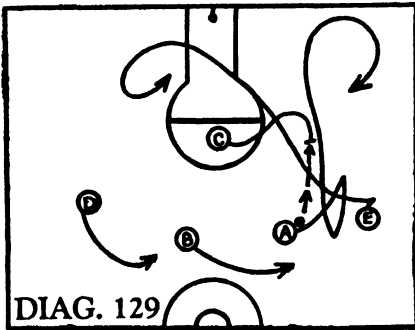

Diagram 129. A passed the ball to the post player who had cut to the right side of the court. A then started to screen between E and his guard, but used the reverse roll so that E could make the first cut around the post player. E will receive a pass from C if a switch is not made by C's guard and his own opponent is blocked by the turn-around. After E had cut around the post, A ran to the right and circled in the corner so that he would be ready to follow-in should a shot be attempted. If the opponent guarding A goes on the left side of the post in following him, he (A) will be able to stop, receive the ball from C, and attempt a short set-shot.

Diagram 130. A passed the ball to C, screened between E and his guard, faked left, and then drove around the post in an attempt to start a turn-around play. Since A was the first player to cut by the post, he would be expected to reverse back in front of the basket if he did not receive the ball on the cutting play. E waited until A had cut by C and then circled to the left of the post, prepared to follow-in.

Diagram 131. The principles of the turn-around series are observed in this play, which follows a dribble by the post player. A passed the ball to B and screened in front of the defensive opponent. B then passed the ball to C, who dribbled to a turn-around position on the right side of the court. A reversed direction and cut around the post in an attempt to force a switch play. Since he was the first player to cut by the post, he reversed in front of the basket. After A had cut around the post, B drove to the right hand corner.

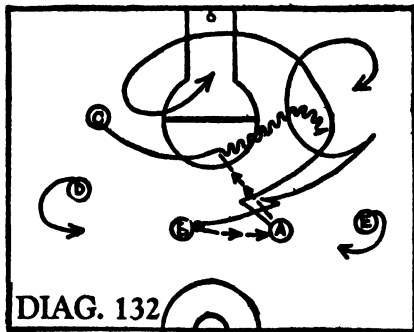
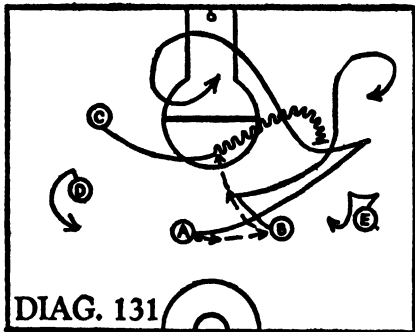
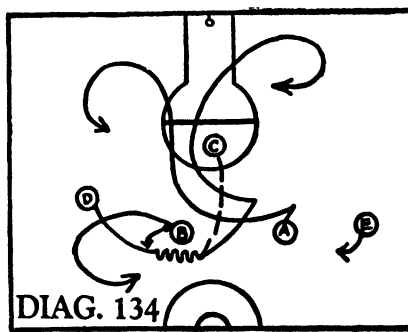
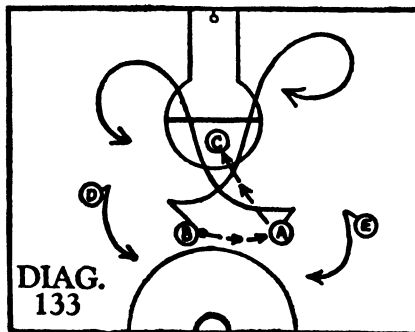

Diagram 132. In this play B passed to A, using a change of pace to screen. A passed the ball to C and followed the pass by starting to the left and cutting to the right around the dribbling post player. It may be possible for him to break free in this play because C's guard may be delayed in switching. B reversed after A had cut around the pivot and circled to the corner. Naturally, his path would be changed, provided an opportunity for a play resulted from the dribbling and cutting tactics of C and A.



FREE-THROW LINE POST PLAYS: Diagram 133. When the post player is stationed in the outer half of the free-throw circle, split-the-post plays are attempted. In this illustration B passed the ball to A, started to the left, and cut to the right of C. After receiving the ball, A immediately passed to C, faked right, and cut to the left. This familiar split-the-post play is the best of a great variety of plays which are directed toward defensive switching.

BLOCKING POSSIBILITIES: Diagram 134. Player B started this play by passing to D, who dribbled a short distance and then hooked the ball to C on the post. Following his pass, he started to the right and changed direction to the left. Player A was second to cut. He started to the right and then drove to the left in an attempt to set up a trailer situation by following D. C could pivot when he received the ball, depending upon the positions of the opponents who were guarding A and D.

TRAILER PLAY: Diagram 135. This trailer play is started by A, who dribbles to the left and passes the ball to C on the post. He then runs a short distance to the left, reverses direction, and cuts to the right. Player D starts for the basket in order to drive his guard back, changes direction, and cuts hard to the right of C. If his guard follows him, D can continue on toward

the basket. However, if the opponent moves in back of C in attempting to follow him, D should stop in front of C for a set-shot. Since A is the first man to pass the post-block, he is expected to reverse back in front of the basket. If the ball is passed to D and he attempts a set-shot, C and A will follow-in.

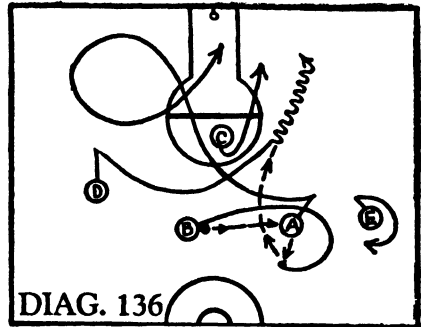
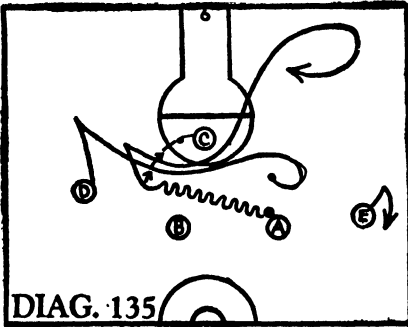

BLOCKING POST: Diagram 136. The post player may be used as a legal block instead of a medium for feeding cutting players. In this illustration B passed the ball to A, screened in front of the defensive opponent, and circled as shown. A returned the pass to B, faked right, and cut to the left around the post man C. On the left side of the court, defensive player D used this opportunity to feint to the left and cut hard to the right in front of the post. The stationary position of C may enable D to receive a pass from B near the free-throw line and dribble into the basket for a shot. A, C, and D follow-in.

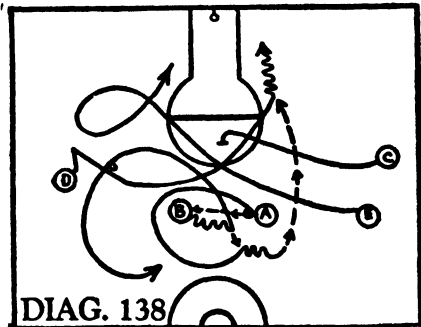
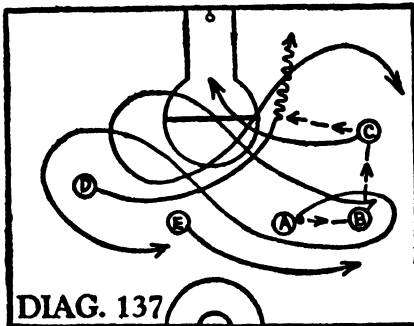

FEEDING POST: Diagram 137. When the use of the post player in the center of the court does not prove effective, he may be shifted near either side line and used as a feeding medium or as a screen for the rear court cutters. In this illustration C has taken a position near the right side line. A passed the ball to B and screened as shown, thereafter cutting back toward the left side of the court. B passed the ball to C and also screened to the left so that D might use a scissors cut down the center of the court and receive the ball from C. After D had cut by, B reversed and followed-in. B, C, and D are expected to follow-in.

SCREENING POST: Diagram 138. A passed the ball to B, screened in front of his guard, and circled as shown. After dribbling a short distance, B

returned the ball to A, cut to the left, and reversed to the rear court. The post player C and his teammate (E) used a double screen toward the left side of the court. However, C had an opportunity to establish a set post position in the outer half of the free-throw circle. D faked to the left and used a scissors cut in back of E and in front of C in an attempt to lose his guard. A passed the ball to D just as he passed the double screen. C, D, and E are expected to follow-in.

Double Post Attack

The post players may assume center positions near the free-throw line so that the attack can be directed along the sides of the court and toward the basket or they may be stationed near the side lines and the center kept open so that scissors and cutting plays through the center of the court can be used.

When the post players operate near the free-throw line, considerable passing ability is necessary because of the congestion which will result in front of the basket. Teams using this style depend upon a strong follow-in by both post players after an attempted score.

The best results are probably obtained by stationing the post men near the side lines so that the center of the court and the under-basket area can be kept free. If the two post players are good marksmen, it will be dangerous for their opponents to float into the center of the court and then the cutting plays may be effective.

There are a number of advantages to this set-up, the chief one, of course, being that the players are in position to maintain good defensive balance at all times. The extended positions of the players almost guarantees them an opportunity to break loose. Once a player has broken into the front court unguarded, there is little danger of an opponent switching to him in time to stop a score. The chief disadvantage is with respect to the follow-in possibilities. The defense is so assembled that the attacking team can easily be blocked out of the rebound area.

Team Selection

POST PLAYERS: If possible, the two post players should be centers. Their height will be an advantage in receiving and passing the ball and, in addition, tall men can usually be developed into good set-shots. Their offensive and defensive duty will require an unusual amount of rebound work and they should be experts in following-in, blocking out, and retrieving the ball. The post players should possess large hands and, of course, be the best jumpers and feeders on the squad. They will be able to secure a great number of corner set- and side bank-shots.

REAR COURT PLAYERS: The three players who are stationed in the rear court are really forwards. The chief scoring threat is built around their abilities. One should be tall and serve as the rear court quarterback. He should use standing guard tactics since his two teammates will continuously drive toward the basket. The height of the quarterback will be an advantage in

feeding and will also aid him in handling return passes if the cutters or post men are too closely guarded to complete a play.

The rear court players should thoroughly understand screening and give-and-go plays and be experts in the use of starts, stops, pivots, turns, change of direction, and change of pace. When the center of the court is open they can use these methods to break free and cut or dribble to the under-basket scoring area.

STYLE OF PLAY: The attack is developed around the ball-ahead-of-the-man. Every effort is made to pass the ball ahead to one of the post men so that the rear court players can drive to the basket. The post players usually float laterally and vertically in meeting passes so that the ball can be protected. A premium is placed upon cut-shots, the short set-shot following a stop, and the dead center set-shot.

CIRCULATION: The principle that an attacking player making a long cut can outrun his guard to the basket is followed. The flat figure eight is used in the rear court for screening, give-and-go plays, and to protect the ball when it is being passed forward to one of the post players. The cutting is restricted to one player at a time, although a rear court teammate may screen toward the basket in starting a play. If the post players are not too slow, they can blend into the circulation by driving toward the basket and then up the sides until they can reassume their original post positions.

DEFENSIVE BALANCE: The side line double post attack provides ideal protection against the quick-break. One of the three men working in the rear court is invariably in a position to fall back on the defense. If a give-and-go type of play has been used, both of the post men may drop back to aid in setting up defensive balance. When one of the post players is engaged in a play, the other may retreat on his side of the court to protect that area from an attack by the opponents.

DOUBLE DUTY: The double post attack can be efficiently used against any defense. Opposed to the man-to-man defense it is effective from the viewpoint of turn-around, post, block, and screen plays. Against the screen-switch defense, the post men can be used as legal blocking positions into which the rear court players can drive their switching opponents. Applied to most zone defenses the double post attack is successful. In meeting the pressing defense, the post attack is important because of its safety in protecting the ball.

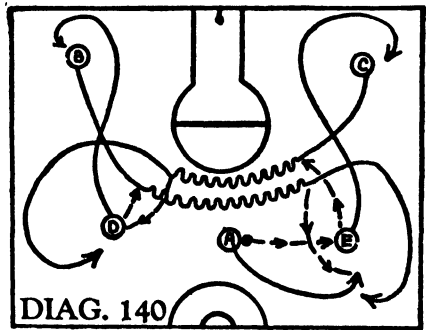
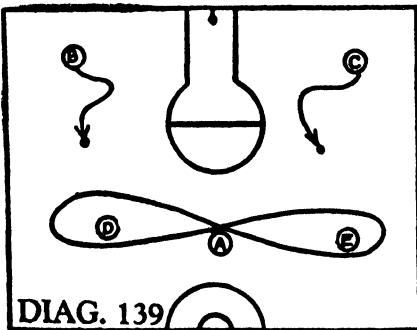

MOVING POSTS: Diagram 139. The defensive players assigned to guard the post men often play them so closely that their rear court teammates find it difficult to get the ball into their hands. For that reason, the post players should be taught to maneuver and break out from the corners to good receiving points when a teammate is in a position to make a pass. In this illustration the post players B and C are shown breaking out from the corners to their regular formation positions. Not infrequently it may be necessary for these post men to break out to the ball and set up post-blocks when the rear court teammates are being played closely by opponents.

DOUBLE POST FREEZING: Diagram 140. The double post formation lends itself readily to a good method of freezing the ball. In the illustration A passed the ball to E and followed the pass. C broke out from the right corner, received the ball from E, dribbled across the court, and passed to D. (After E passed to C, he cut toward the basket and circled in the right corner.) B advanced from the left corner, received the ball from D, dribbled across the court, passed to A, and circled toward the back court. After passing to B, D cut to the left corner and circled as shown.

The opponents often become aggressive in opposing this freezing method and try to steal the ball. This will provide an opportunity for an attacking player to cut for the basket. The cut toward the goal is usually made from the side of the court.

Double Post Plays

Diagrams 141 to 156, inclusive, illustrate how the double post attack is developed through a continuity determined by the passing of the ball and the cutting by the players. These plays work on either side of the court but it is not considered necessary to show this duplication in the diagrams.

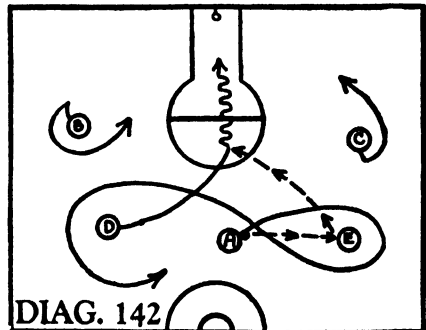
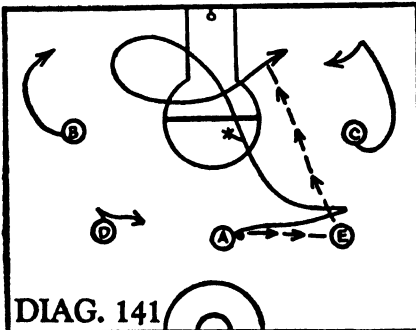

GIVE-AND-GO PLAYS: Diagram 141. Because of the open court, give-and-go plays can be developed by players A, D, and E. It is not believed necessary to diagram a number of these plays since they were discussed in detail in Chapter VI. In this illustration player A passed the ball to E, screened in front of the defensive player, changed direction, and cut for the basket. A reversed direction when he arrived in scoring territory and received the ball on the right side of the goal. The post men, B and C, can help the success of the rear court give-and-go plays by faking to drive under the basket along the side lines. This will prevent their respective opponents from

floating under the basket, intercepting passes, or switching to a rear court cutter.

REAR COURT SCREENING: Diagram 142. Scissors plays can be effectively used in this formation. In the illustration A passed the ball to E, screened, and used a flat figure eight path to set up a scissors situation so that D could cut toward the basket. As soon as A screened between him and his guard, D drove down the middle of the court and received the ball as he reached the free-throw circle. The post players are expected to follow-in but should maneuver their opponents until the play is developed.

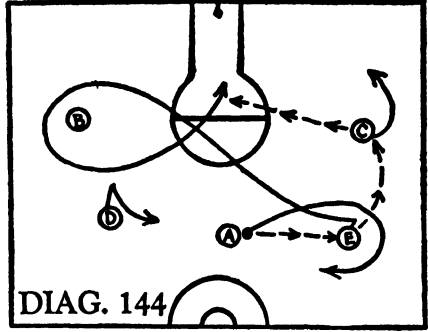
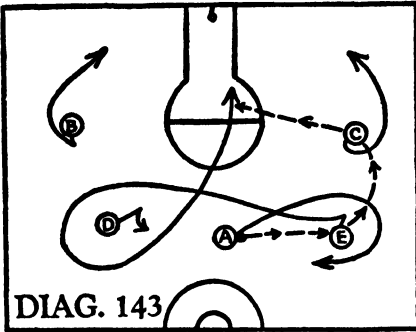

REAR COURT SCREEN AND CUT: Diagram 143. A passed the ball to E and circled as shown. E passed the ball to the post player C, faked right, screened in front of D on the other side of the court, and cut down the center of the court toward the free-throw line where he received the ball from C.

FRONT COURT SCREEN: Diagram 144. A started the play by passing the ball to E and circling as shown. E passed to C, faked right, and cut toward the left corner. After screening between B and his guard, E circled sharply, cut toward the basket, and received the ball from C in the free-throw lane.

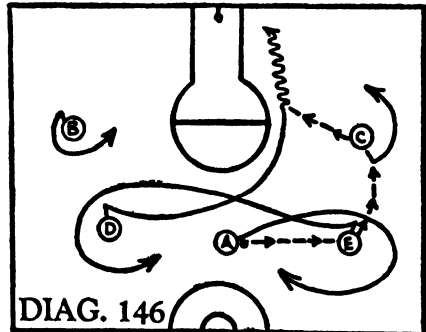
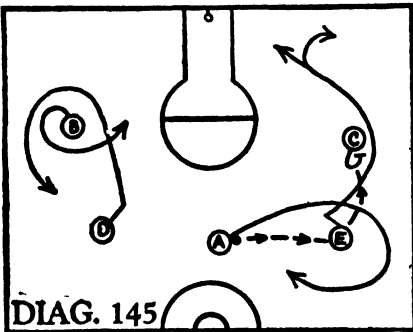

THE TURN-AROUND: Diagram 145. Player A passed the ball to E and screened to the right. E passed the ball to C, faked left, and cut along the side line. As soon as C received the ball he pivoted, faced the basket, and held the ball high above his head, prepared to utilize the turn-around series, providing a post-block resulted. If he did not receive the ball, E would retreat up the right side of the court.

SCREEN AND POST PLAY: Diagram 146. A again passed to E and screened. E passed the ball to C, faked to the right, changed direction, and screened cross-court to provide a scissors opportunity for D. After faking to the left, D cut as close as possible to E in an attempt to gain a step or so advantage upon his guard. He received the ball from C at the free-throw line and dribbled toward the basket. After passing the ball, C pivoted and followed-in. B on the other side of the court also followed-in for the rebound.

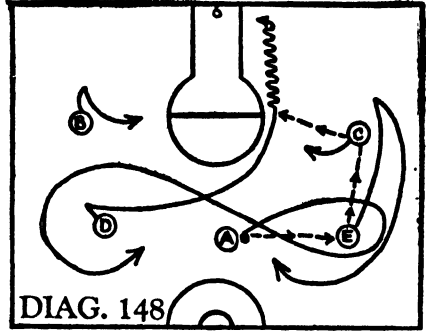
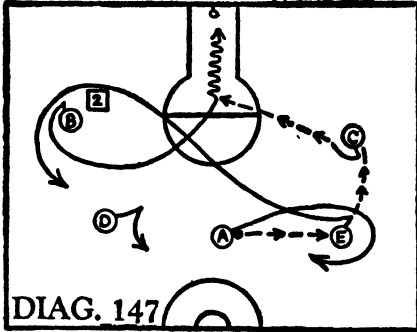

SCREENING THE POST PLAYER: Diagram 147. After receiving the ball from A, E passed to C, faked to the right, and screened deep cross-court behind defensive 2. B faked left, used the screen provided by E to make a scissors cut toward the basket, and received a pass from C in the free-throw lane.

COMBINATION PLAY FOR A REAR COURT PLAYER: Diagram 148. After receiving the ball from A, E passed the ball to C and cut along the side line. A screened between E and his guard, reversed direction, and set up a scissors play for D. D cut hard for the basket and received the ball from C near the free-throw line. E retreated up the side line as soon as he saw that C did not intend to use the turn-around series. B and C followed-in. The defensive balance was established by A and E.

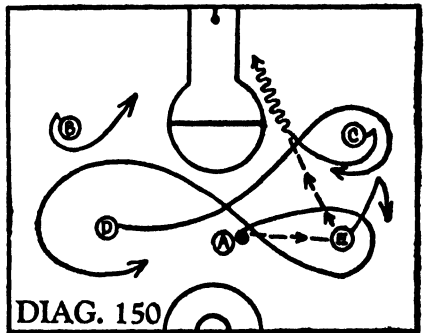
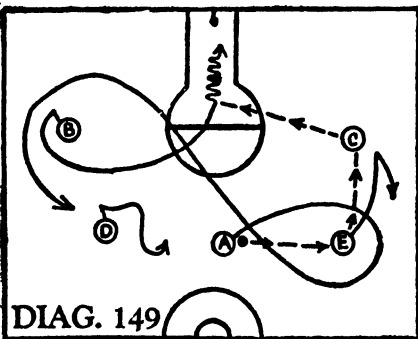

COMBINATION PLAY FOR THE POST PLAYER: Diagram 149. Player A passed the ball to E, screened in front of the defensive guard, circled to the rear, and drove hard cross-court toward the left corner. E passed the ball to C, started forward for a turn-around play, but retreated when he saw that C had not pivoted. B faked to his right and used a scissors cut close behind A to drive toward the basket. C passed B the ball in the free-throw lane.

A POST SCISSORS PLAY: Diagram 150. After passing the ball, A screened for E and D. D used a scissors cut behind A and then screened back of C's guard. C in turn used a scissors cut close behind D and received a pass from E near the free-throw circle. B and D followed-in.

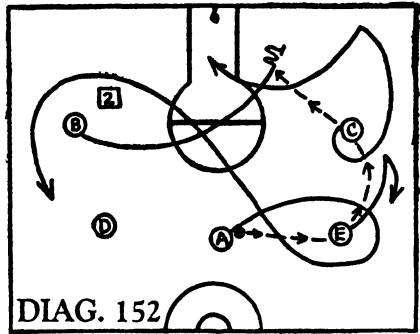
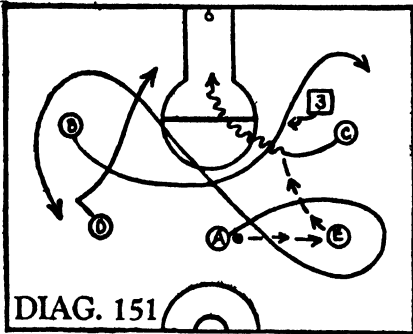

DOUBLE SCREEN FOR POST PLAYERS: Diagram 151. After passing the ball, A screened in front of E and cut diagonally across the court to provide another screen for B. As soon as A passed, B crossed the court and cut behind C's guard (3). C cut laterally across the court, received the ball from E, and dribbled toward the basket. Rear court player D followed-in.

SCREEN AND PIVOT BLOCK: Diagram 152. A employed an inside screen between E and his opponent, reversed direction, and used an outside screen behind defensive player 2. B cut cross-court to a pivot position under the basket. C received the ball from E, faked a return pass to E, and then hooked the ball to B. Pivoting to his left, C circled to the corner, changed direction, and cut in front of B under the basket.

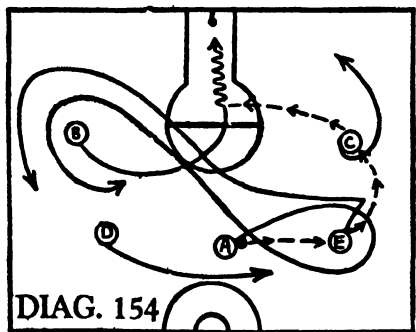
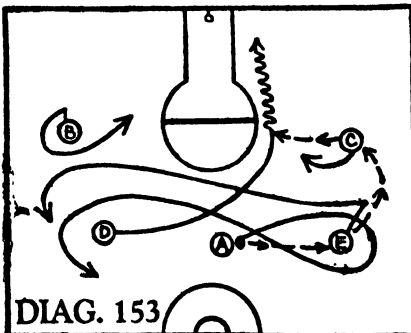

DOUBLE REAR COURT SCREEN: Diagram 153. A passed the ball to E, screened in front of the guard, circled back, and started a flat figure eight path laterally across the court. After receiving the ball, E passed to C, faked right, reversed direction, and screened across the court behind A. Player D used this double screen to drive hard down the center of the court to the free-throw line where he received the ball from C. B and C followed-in.

DOUBLE FRONT COURT SCREEN: Diagram 154. A and E again set up a double screen. In this situation the screen was directed toward the left corner so

that B might use a scissors cut to drive toward the basket. After receiving the ball from E, C pivoted and passed to B who cut through the free-throw lane. Rear court player D cut across to the right side of the court to establish defensive balance.

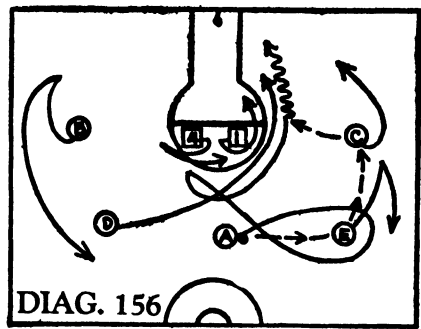
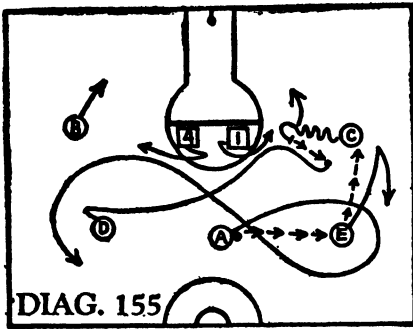

CHANGING DIRECTION AGAINST A SWITCH: Diagram 155. After passing the ball to E, A screened and provided a scissors cut situation for D. As D started toward the basket, he noticed that 4 and 1 were switching. His individual opponent (4) shifted to A while 1 prepared to guard him (D). Player D then faked to drive on under the basket, changed direction, and cut behind C, who had dribbled toward the free-throw line. A good set-shot is possible. B and C follow-in.

A REVERSE AGAINST A SWITCH: Diagram 156. After A had passed to E and screened, he noticed that opponents 1 and 4 were preparing to switch. As soon as D cut across behind him, A reversed direction and followed D toward the basket. This maneuver resulted in some confusion between defensive 4 and 1, and A succeeded in using his teammate D and opponent 1 as a screen between himself and 4. A received the ball from C and dribbled in to the basket. C and D followed-in while B retreated to set up defensive balance.

CHAPTER X

SINGLE AND DOUBLE PIVOT ATTACKS

THE USE OF pivots in player maneuvering and cutting is usually associated with protecting the ball. The use of the pivot as a team offense means that the pivot player will be stationed in a position so that he can score, dribble to the basket, or feed cutting teammates. The pivot is not planned for ball protection except as this need arises in the general play of the game. In a post or a double post attack, the back-up player may or may not be the important factor in the offense. However, in the pivot attack the offense is built around his abilities.

Pivot attacks operate in so many ways that it is impossible to set up all of the possibilities. This chapter will be limited to one phase of the single, double, and triple post attacks. All of these may comprehend a continuity of players in the various positions. When such a continuity or rotation is

used, each attacking player moves to the corner, side, under-basket, or rear court position in turn and breaks to the ball in setting up plays. This rotation offense, of course, requires that all players be versed in the use of the post, turn-around, scissors, screening, and pivot scoring plays which are included in the pivot attack. The chief advantage of this position continuity is that it permits the attacking players to determine which of the defensive opponents are weak in switching and guarding abilities.

Pivot attacks may comprehend stationary pivots, the use of dribbling, or moving from one point to another in the under-basket scoring area. Probably the most success will be obtained when pivot players maneuver in and out of their set positions instead of remaining stationary.

The Pivot Player

A pivot player may be defined as one who remains under or near the basket with the express purpose of scoring by means of a number of specialty shots and who is used incidentally as a passing and blocking medium. The chief purpose of the pivot player or players is to score. (When more than one pivot player is used an important function of their playing technique comprehends a strong follow-in of all shots.)

HEIGHT: Pivot players are usually chosen for under-basket duty because of their height. An increased advantage accompanies height when the player is well proportioned or heavy in build. Defensive guarding has become so efficient that tall, slender players can usually be forced away from the basket and their effectiveness as scorers decreased.

MANEUVERING: Maneuvering tactics may be used by the pivot player to reach his favorite scoring position. Pivoting away when closely played by his opponent, breaking toward the ball from the opposite side of the court, driving in toward the basket from the vicinity of the free-throw line, and cutting out of the corners are simple maneuvers which often enable him to reach his objective. The pivot player can use a number of signals to inform teammates just where he wishes the ball to be passed. The use of the eyes, motions with the head, pointing with the finger, or even talking signals may be used to convey this information to teammates. (Opening and closing the first may be used as a signal system for passes.)

The pivot man must keep in mind that a scoring play by a teammate can be spoiled because he failed to clear out of the under-basket area. When the pivot player moves away from the play, his respective guard may switch. He should expect this switch and be prepared for a pass from the cutting teammate. (Return pass plays which are designed to provide the pivot player with quick shooting opportunities following a switch should be a planned and practiced part of the attack.)

CATCHING THE BALL: Unless the pivot player is heavy or strong enough to maintain his scoring position under the basket, it will be necessary for him to meet the ball. A high toss can be best protected. However, a great number of pivot players are able to catch the ball chiefly because of their ability to use body weight and legs in preventing the opponent from reaching a good guarding position. In catching the ball the player should advance his hands as far as possible so that the ball is kept at arm's length.

BODY BALANCE: There is a difference of opinion among coaches regarding the body position the pivot player should assume; whether he should bend over in handling the ball or maintain an upright position. Practically all coaches are agreed that the feet should be comfortably spread so that the legs may be used for blocking. If the pivot player is heavily built, it is probably best to maintain an erect position and hold the ball at arm's length. Then a simple turn of the shoulders and hips will enable him to keep his opponent away from the ball. The upright position is, of course, best adapted to shooting whereas the bent position is undoubtedly best for feeding purposes. (The pivot player should be careful not to keep his feet spread so far that he cannot use a step-away or jump shot.)

FEINTS AND FAKES: Feinting with the body and faking with the ball are important in securing openings for passes or shots. The pivot player should depend upon cutting teammates for assistance in making passes or attempting shots and the other players should recognize the importance of screening or cutting around him so that he can use them as decoys. In feinting with the head before a shot, the player should really look at the basket not only to deceive his guard with respect to his intention to shoot but to locate the goal so that his actual attempt will be more accurate. The pivot player should know his exact position on the floor with relation to the basket. A number of means may be employed to determine just where he is standing, for example the markings of the free-throw lane and the end or side lines of the court.

SHOOTING: The ability to score from a pivot position is difficult to develop. A number of players have a feel for the backboard which permits them to use a great variety of shots. Undoubtedly the scoring of a pivot player will depend to a great extent upon the assistance given him by his teammates. If the ball is not passed to him at the correct time and in the correct position, his effectiveness will be limited.

There are a great number of shots which may be attempted by a pivot player. The most popular are the straight turn shots with the right or left hand, the hook shot in which the player holds his position and releases the ball from an extended straight arm, the jump shot with one or two hands accompanied by a twist of the body, the underhand shot which is designed to vary the overhand throw and/or draw a foul, the one-and two-hand push shots when facing away from the basket with or without a jump in the air, the one- and two-hand overhead shots, the step-away with the left or right hand, the short set-shot after a turn-around or from the corner, and the one-hand shot facing the basket.

It is too much to expect one player to master all of these shots. Probably one specialty shot can be developed to a high degree of accuracy and one or two others as alternates. Before the pivot player makes a scoring attempt he should visualize the shot. This will greatly aid in the development of accuracy and will enable him to go through the preliminary maneuvers with speed and sureness.

Since a great number of defensive measures may be used to check the scoring activity of the pivot player, his teammates must be prepared to take advantage of them. The pivot player must understand that when an opponent is floating back to assist in guarding him, the teammate opposing this

player will be expected to move and receive the ball. When the pivot player is being double-teamed, a teammate is free somewhere. It is the pivot player's task to find this teammate and pass the ball to him as quickly as possible. When the assigned opponent plays in front of the pivot scorer, offensive players should realize that their teammate is in an excellent follow-in position. A high loop pass or a shot should be attempted as quickly as possible so the pivot player can take advantage of his inside position.

All members of the team should be aware that the pivot attack is being used because it is the strongest scoring weapon they possess. Since the pivot attack is the chief style of play, it should be utilized at every opportunity and there is no reason to develop other offensive measures unless so instructed by the coach.

FEEDING TEAMMATES: The pivot player must master several passes with which to feed his teammates. Possibly the best passes he can use are those which are possible when the ball is kept close to the floor and protected by the legs. From a crouched position underhand, flip, back, and bounce passes will probably work best. Naturally, all passes can be used to better advantage when the pivot player's guard is concentrating on stopping a shot (particularly the bounce pass).

The pivot player will be able to make passes most efficiently when they are timed with the cut of a teammate. His opponent in such instances is concerned with the possible necessity of switching and may not concentrate so closely upon the ball.

DRIBBLING: The ability to dribble is an excellent asset for the pivot player but he should keep in mind that practically all defensive teams congest the under-basket scoring area and he will not have much time nor room to use this weapon. Probably one or two bounces are the limit unless he is dribbling toward the rear court in order to protect the ball. When in the back-up position and a dribble is attempted following a fake pass to a teammate, it is best to make the first bounce with the hand on the side in which the pivot player turns. The second and following bounces can be made with the opposite hand. This method enables the player to pivot quickly and maintain a low protective position in dribbling the ball.

OFFENSIVE REBOUNDS: All pivot players are expected to develop offensive rebound ability. The use of the spin sometimes enables the pivot player to maneuver into position following his or a teammate's shot. When he is opposed by a guard who uses his body in blocking the pivot player away from the basket, it is wise to back up a step or so and then drive in for the ball after the direction of the rebound is determined. The use of the legs is important in securing and keeping a good rebound position under the basket. (A wide base should be used.) In attempting to check the quick-break at the source (the first pass), pivot players are expected to follow-in all shots and if unsuccessful in securing the rebound, play the opposing rebound guard so closely that he cannot get the ball away quickly.

FEEDING THE PIVOT MAN: Stationary pivot men should be fed from the sides of the court. At no time should a pivot scorer be fed from the rear court because the side position most guards use in opposing a pivot player is such that an interception or deflection is likely. A rear court pass to the pivot man should be used only when he is cutting across the court so that

his body can be kept between the ball and the guard, or when he is breaking out toward the center of the court to help teammates who are in difficulty. In feeding the pivot scorer, teammates should concentrate their attention upon his opponent and then direct their passes away from the guard. They need not worry so much about the pivot scorer getting the ball since he is watching it and is prepared to move to whatever position is necessary.

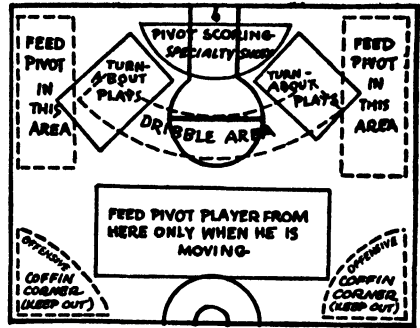
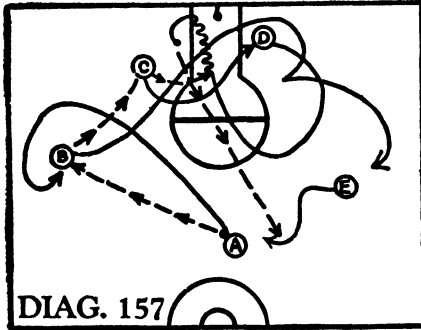

ROTATION PIVOT ATTACK (Rolling Offense): Diagram 157. Players A, B, C, D, and E are moving from one position to another and interchanging so that each may have an opportunity to feed, cut, dribble, or attempt a shot. The purpose of this attack is to determine which opponents are most susceptible to the various plays which are possible.

All players must be well versed in the requirements of the various positions. Because there are no definite position assignments, this type of attack requires an experienced all-around squad.

In the illustration A passed the ball to B and screened in front of the defensive player. B forwarded the ball to C, who could attempt a shot if he received the ball in a good position. However, C passed the ball to D, who had started up the side of the court and reversed direction toward the basket. D dribbled to a position under the basket and C screened across to the right side of the goal. B had followed the pass and would have taken the pivot position on the left side of the lane if it had been unoccupied. However, D had assumed that position and since the right rear court position was vacant, B replaced E. E received the ball from D and started the continuity once again. After this first shifting of players, E has taken A's place, A is in the position first occupied by B, D is now in C's position, C is in D's position, and B has replaced E.

PIVOT ATTACK AREAS: Diagram 158. The areas in which particular plays by pivot players may be attempted are shown in this illustration. The under-basket area is confined to pivot shots and the two rectangles on each side of the free-throw circle bound spaces in which turn-around plays are most efficient. The area enclosed by the broken lines on each side of the front court should be used for feeding the pivot players when they are attempting to score. The dribble area which extends from the corner and across the free-throw line is used by the pivot player when he breaks out from the corner toward the ball and dribbles or moves to the opposite side of

the court to set up a play. The pivot player should be fed from the center of the court only when he is breaking out of the corner and moving toward the ball. The two corners in the rear court are known as the coffin corners and should be avoided by the attacking players whenever possible.

The Single Pivot Attack

The single pivot attack may be used strictly for business (scoring) or as a feeding medium for cutting players. When designed to advance the ball into the hands of a pivot player so that he may score, it is difficult to plan plays. The chief offensive difficulty has to do with the maneuvering of the pivot player so that he may secure a position where good shots can be attempted.

When the pivot player is used as a feeding medium, best results will undoubtedly be secured when he moves toward the ball from a position under the basket or breaks out from the corners. It is important that he keep the scoring area clear when the rear court players are attempting to cut to the basket. The pivot player should dribble to the side of the court and then pass laterally to cutting teammates.

When the single pivot attack is used, the pivot player must possess strong scoring or feeding ability or the offense will not be effective. It is difficult to develop team play when this attack is used because the pivot player will undoubtedly be the leading scorer and receive most of the *write-ups*. The success of the style of play will depend to a great extent upon the pivot player's personality. If he is well liked and carries his scoring success modestly, his teammates will usually co-operate by feeding him the ball at every opportunity.

A great many rear court players dislike to pass the ball to the pivot player because he usually attempts to score without returning the ball. The most successful pivot scorers are those who immediately return the ball to a rear court teammate when they are not in a good position for a pivot shot.

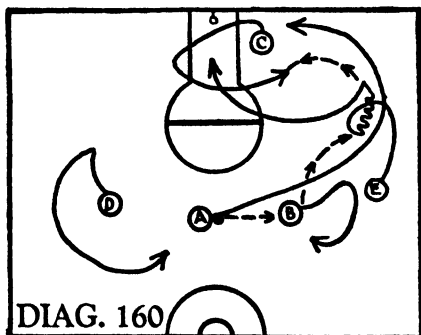
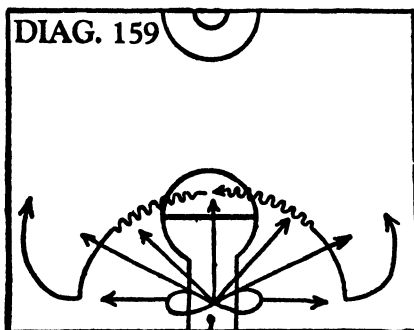

When a give-and-go or screen play develops in the rear court, the pivot player should understand that the under-basket area is to be cleared. If he is clever, he will be able to move away from the basket in such a way that his guard will be forced to follow him. Whenever his individual opponent floats away or switches to a cutting player, the pivot player will have many opportunities for a quick set-shot from the turn-around areas or the corners.

PIVOT PLAYER MANEUVERING: Diagram 159. The paths the pivot player can follow in blending in with the general attack or in maneuvering for a good scoring position under the basket are illustrated.

INSIDE AND AROUND PLAY: Diagram 160. Player A passed the ball to B and screened in front of the opponent. Player E cut toward the right corner, reversed direction, received the ball, dribbled a few steps, and passed to C near the basket. He then followed his pass to the left of the pivot-block. Player A had continued his path and circled around E just as the pass was given to the pivot player. C could shoot, return the ball to E, or feed A under the basket.

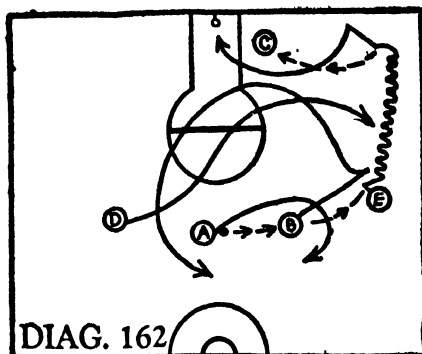
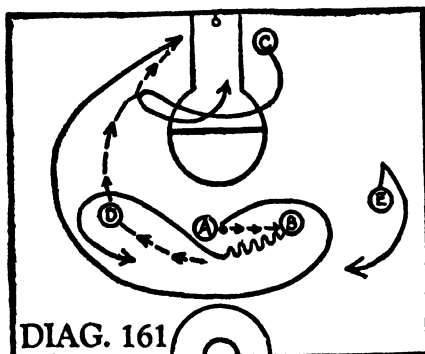

OUTSIDE AND AROUND PLAY: Diagram 161. A passed the ball to B, screened in front of his guard, and cut around the outside of the court. As soon as B received the ball he dribbled a short distance, passed to D, screened in front of him, and reversed as shown. D passed to the pivot player (C), who had cut across the free-throw lane, and set up a pivot-block around which A cut to the basket. C passed the ball to A and pivoted to follow-in.

FEEDING THE PIVOT PLAYER: Diagram 162. The ball was passed from A to B to E. A and B both screened and reversed as shown. As soon as he received the ball E dribbled to the right corner, passed to C on the pivot.

tration A passed the ball to B and screened as shown. B passed the ball to E, screened in front of him, and circled back toward the middle of the court. As soon as E received the ball, he dribbled to the corner and faked a pass to C. Rear court player D timed his cut so that he could use B for a screen. He cut in front of the pivot player C and received the ball from E. If unguarded he could attempt a shot. If opposed, he could pass the ball to C or use a return pass to E.

REAR COURT SCREEN: Diagram 164. A passed the ball to B, screened in front of his guard, reversed to the rear, and cut in front of his teammate D. B passed the ball to E, faked to the left, and cut toward the right corner. As soon as he had forced his guard off balance, B reversed, received the ball from E, and passed to C on the pivot. Player D faked to the left, waited until A screened between him and his guard, and then cut through the middle of the free-throw lane. C had the option of shooting, passing to D, or returning the ball to B near the free-throw line.

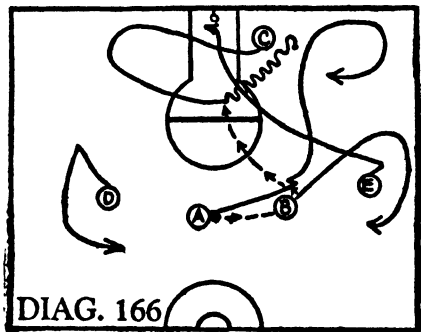
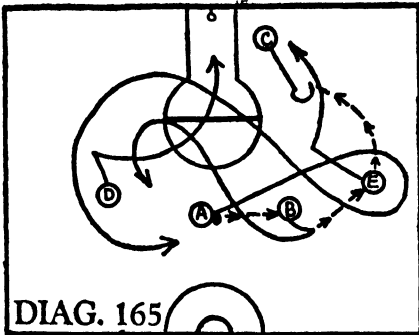

REAR COURT DOUBLE SCREEN: Diagram 165. A passed the ball to B, screened in front of the opponent, and continued on over in front of E. He then circled back and started a long screen toward the left corner. As soon as B received the ball from A he pivoted, passed to E, reversed, and screened across court. E passed the ball to C, faked to the left, and cut around the pivot in an attempt to develop a turn-around play. On the other side of the court D timed his cut toward the basket so that he could take advantage of the double screen set up for him by A and B.

SCREEN AND PIVOT DRIBBLE: Diagram 166. Player A passed the ball to B and screened in front of the opponent. He then cut to the right hand corner and reversed toward the basket. The pivot player had maneuvered to the left side of the court and reversed direction to the free-throw lane where he received the ball from B. He dribbled a short distance and set up a pivot position on the right side of the basket. Following his pass to C, B screened in front of E, who faked to the right and cut hard toward the basket. C had the option of shooting, passing to E under the basket, or throwing the ball back to A, who was set in a good bank-shot position.

Multiple Pivots

The use of two or three pivot players in the under-basket area implies that the team is fortunate in having several tall and strong players who

are best adapted to under-basket scoring and follow-in tactics. The congestion which is a natural result of the stationing of these pivot scorers near the basket means that they must have good passing ability as well as an understanding of the value of possession of the ball.

Since the strong under-basket attack will undoubtedly cause the massing of the defense there, the rear court players should possess good set-shots. A successful multiple pivot attack may depend almost wholly upon the use of the set-shot for scoring because the pivot players are so strong that the ball is constantly being retrieved and passed back to the rear court.

The use of multiple pivots can be vertical or lateral and on one or both sides of the basket. When the pivot players are stationed close to the lane, they are expected to be good scorers. Moving around one another, they are able to force switch tactics on the part of the defense and may secure a great number of pivot shots. When the players are removed from the basket, their offensive value is dependent upon passing and cutting ability.

In some attacks the pivot players are used entirely for follow-in purposes. If they do not have good scoring ability it is foolish to keep them near the basket unless they are expert in following-in, securing the ball, or making tip-in shots.

VERTICAL PIVOTS: Shortly after Leonard "Dutch" Dehnert popularized the modern post play, the under-basket pivot attack developed. It was not long before a combination post and pivot attack began to function. In this under-basket offense two strong pivot players assumed vertical positions in front of the basket and a number of plays developed. However, the defense began to mass in the scoring area to check the dangerous under-basket attack and its effectiveness was somewhat decreased.

Considerable passing ability is required on the part of the vertical pivot player farthest from the basket. However, when accompanied by the cutting of a rear court teammate, a strong attack results. Good ball handling ability is the chief requirement on the part of B and C (vertical pivot players), and size is important.

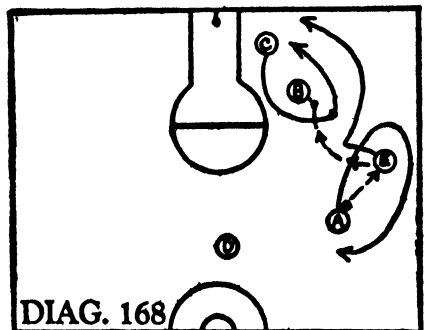
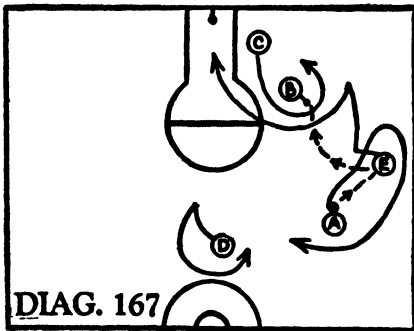

VERTICAL PIVOT SCREEN: Diagram 167. A passed the ball to E, screened, and retreated to the rear court. E passed to B on the front pivot and used a change of direction to drive toward the basket. As E cut to the left of B, the under-basket pivot player cut around to the right of B. If his guard did not follow him, he would stop in front of B, receive the ball, and at-

tempt a short set-shot. If his guard followed him, he would continue around B for a pass, cutting under the basket. B has the option of shooting or passing to E or to C.

TRAILER PLAY: Diagram 168. A passed the ball to E and screened in front of the opponent. E passed the ball to the front pivot player, faked to the left, and cut to the right. As soon as E received the ball from A, C circled in front of B, cut to the basket, and established a trailer play for E. B could pass to the player who was free, attempt a shot, or dribble under the basket.

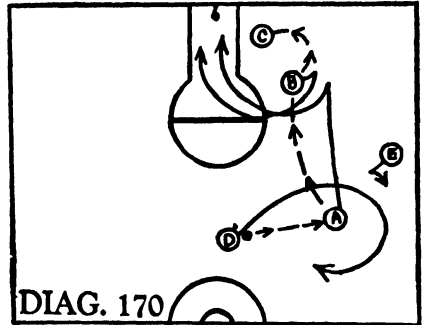
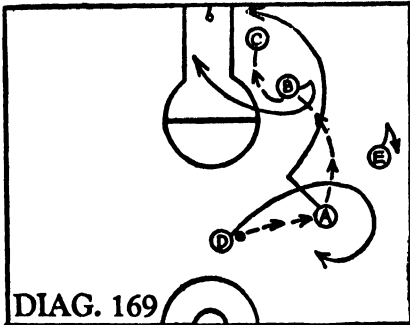

DRIBBLE PIVOT PASS: Diagram 169. As soon as A received the ball from D, he passed to B, faked to the left, and cut to the right. B waited until A cut by him, faked to give him the ball, and used his left hand to pass the ball over his right shoulder to C. He then pivoted to the right and started for the basket. C is in a good position to shoot or pass to A or B.

PIVOT TRAILER PLAY: Diagram 170. A received the ball from D and passed to B. Driving to the right, he changed direction and cut toward the basket. B faked a pass to A and used a back two-hand bounce to give the ball to C. He then pivoted to his right and attempted to secure a trailer position behind A.

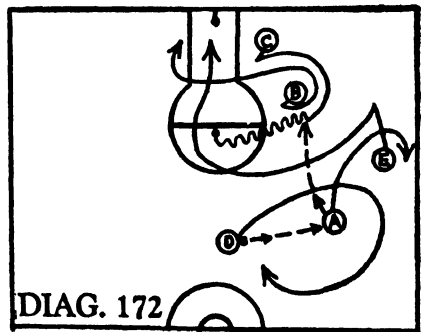
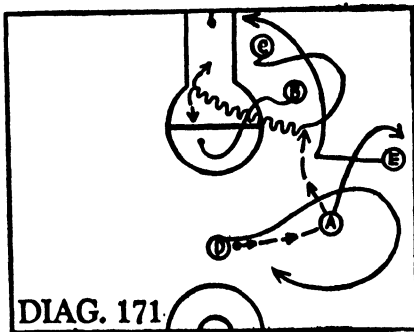

PIVOT CIRCLE AND DRIBBLE PLAY: Diagram 171. Rear pivot player C waited until A received the ball from D and then circled in front of B where he received a pass. After passing to C, A screened between E and his guard. E faked to the left and drove around B toward the basket. As soon as C received the ball, he dribbled toward the basket where he had the option

of attempting a shot, passing to E on the right side, or giving the ball to B who had retreated to the free-throw line. The best pass would be to B on the free-throw line where a one- or two-hand shot could be attempted.

DRIBBLE TRAILER PLAY: Diagram 172. C again broke around B and received the ball from A. After A had screened in front of him, E started to the right, changed direction, and followed C, who was dribbling toward the free-throw line. When C started the dribble, B pivoted to his left and cut across the lane. E continued on in toward the basket and C had the option of shooting or passing to B or E.

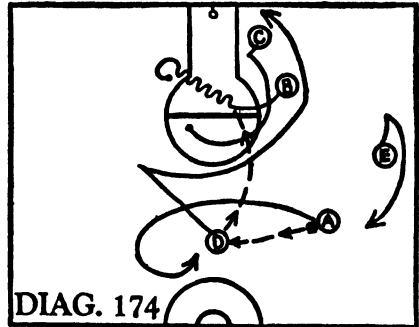
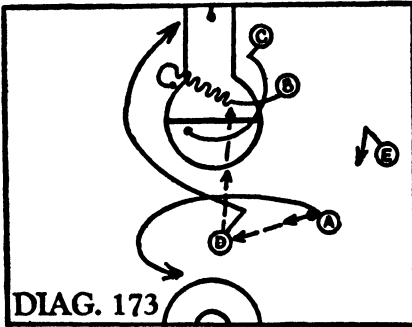

DRIBBLE PIVOT-BLOCK: Diagram 173. A passed the ball to D and screened to the left. B broke across the free-throw lane, received the ball from D, and dribbled to a pivot position on the left side of the lane. D started to the right, changed direction, and cut hard around the pivot position. Anticipating that his opponent would switch to play the under-basket player, C faked to his right and then retreated to the outer half of the free-throw circle, prepared to receive the ball and attempt a quick shot.

REVERSE PIVOT SCREEN: Diagram 174. D received the ball from A and passed to B who again dribbled to the left side of the lane. As soon as B started his dribble, C broke out to the free-throw line. D faked deep to the left and cut on the outside of C toward the basket. If C's opponent follows him to the free-throw lane, there is a possibility that D will be unguarded under the basket.

LATERAL PIVOT ATTACKS: When two pivot players are stationed on each side of the free-throw lane, they may take positions directly under the basket, in the corners, at the junction of the free-throw lane and circle, or near the side lines. When the pivot players are stationed immediately under the basket, there is little opportunity for plays which will incorporate the movement and maneuvering of rear court teammates. The chief purpose of this tight offensive formation is to utilize the height or strength of the two pivot scorers in their under-basket play.

The rear court players can use give-and-go and screening tactics to a certain extent but their scoring efforts will usually be effective only in the vicinity of the free-throw line because of the under-basket congestion. The pivot scoring results from tip-in, pivot, turn, and step-away shots following a pass from a rear court teammate. Some opportunities may be obtained for shots following a dribble or the use of the screen by the pivot players themselves.

When the pivot players are stationed at the junction of the free-throw lane and circle, cutting plays on the part of the rear court players are possible. Most of these plays will be directed between the pivot players and the side lines. A high premium is placed upon possession in this set-up since there is considerable congestion underneath the basket and careless passing will result in loss of the ball.

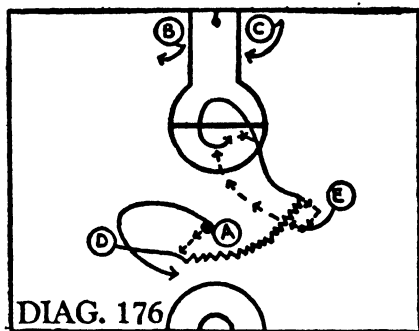
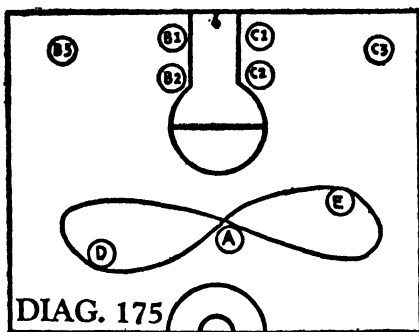

LATERAL PIVOT ATTACK POSITIONS: Diagram 175. Players B₁ and C₁ are situated in the under-basket scoring area. B₁ and C₁ will be unable to develop many plays and the offense must depend upon their follow-in and pivot shot tactics and the rear court maneuvering of A, D, and E for scoring. B₂ and C₂ are in a feeding position close to the junction of the lane and the circle. They may use the one-hand and jump shots for scoring but are usually utilized to feed rear court cutters who maneuver between the free-throw lane and the side lines. Players B₃ and C₃ are situated in the corners where cutting and passing tactics are important. B₃ and C₃ will find it more difficult to use follow-in tactics but a cutting attack will function more efficiently because of the open under-basket territory.

REAR COURT MANEUVERS: Diagram 176. Players A, D, and E are maneuvering so that one of their number can reach the vicinity of the free-throw circle where a one-hand shot or shot-pass may be attempted. B and C are prepared for fake shot passes since the attack is directed toward under-basket scoring. D cut behind A, received the ball, dribbled in front of E, passed to him, and used an "S" cut to the free-throw line where he reversed and received a return pass. He could attempt a one-hand shot or pass the ball to B or C.

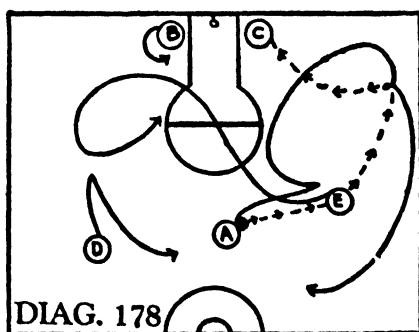
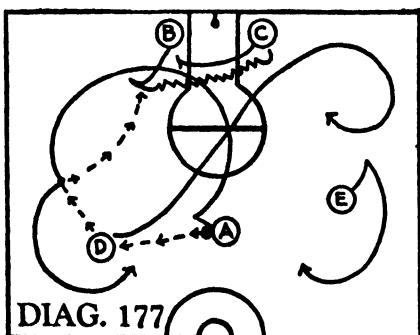

PIVOT BLOCK AND DRIBBLE: Diagram 177. A passed the ball to D, faked to the left, circled around the front court, and received a return pass near the left side line. A passed the ball to B, and C moved to a pivot-block position behind him. Faking to his right, B changed direction and dribbled to the other side of the basket where he attempted a shot. Players D and C followed-in.

FEEDING THE PIVOT PLAYER: Diagram 178. A passed the ball to E, changed direction, and cut to the corner where he received a return pass. From this position he was able to pass the ball in to C who attempted a shot. B and E followed-in.

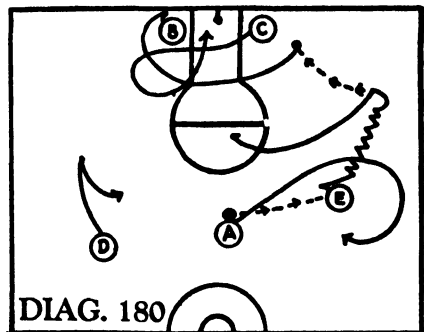
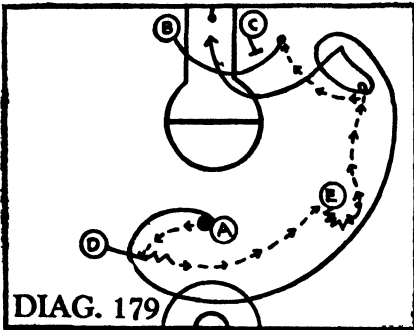

REAR COURT OUTSIDE SCREEN: Diagram 179. A passed the ball to D, screened as shown, and circled to the right hand corner. After receiving the ball from A, D dribbled a short distance and passed to E. E pivoted, dribbled toward the side line, and passed the ball to A, who had reversed in the right corner. When E received the ball from D, C broke out a short distance and established a pivot-block. B cut to the outside of this pivot-block and received the ball from A. He could attempt a shot or return the pass to A, who had faked to the right and then cut toward the basket.

UNDER-BASKET SCREEN: Diagram 180. E received the pass from A and dribbled toward the right corner. C screened away from the ball so that B could break to the right side of the basket and receive the pass. B may attempt a shot or pass to C or E.

Lateral Pivots at Junction of the Lane

PIVOT-BLOCK: Diagram 181. As soon as player E received the ball from A, B cut across in front of C and established a pivot position. E passed the ball to him at this point. Player A screened in front of E, changed direction, used an "S" cut to drive toward the basket, and received the ball from B as he cut by C. B and C both cut to their right, prepared for a return pass from A or to follow-in the shot.

REAR COURT SCREEN: Diagram 182. A passed the ball to E and circled to the rear. As soon as E received the ball, D cut across toward the corner, pivoted, received the ball from E, and used an over-shoulder pass to get the ball to C. A continued his cut from the rear court and screened between D and his guard and in front of C. C has the option of passing to A under the basket or to B on the free-throw line.

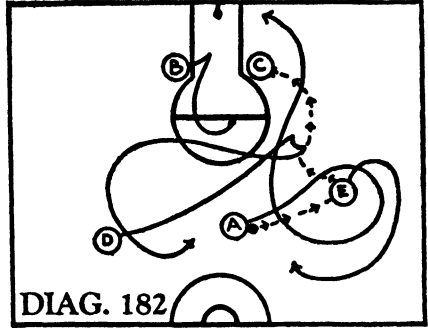
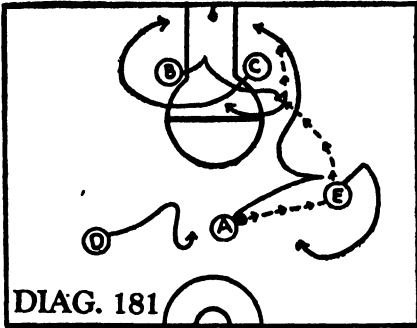

A CUT THROUGH THE LANE: Diagram 183. A passed the ball to E, changed direction, and screened for D, who cut through the free-throw lane and circled in back of C. While D was cutting toward the basket, E had passed the ball to C. When D's guard did not follow him in his use of the reverse cut, C passed the ball to him (D) in front of the pivot-block for a short set-shot.

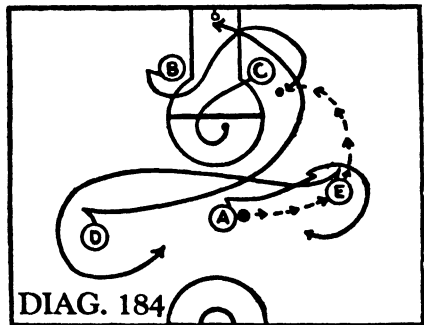
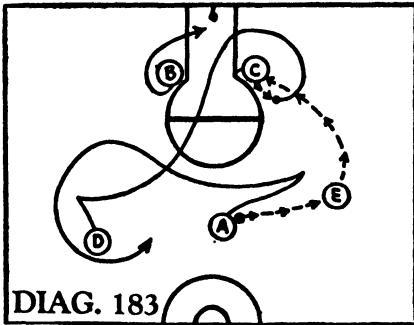

REAR COURT SCISSORS PLAY: Diagram 184. A passed the ball to E and screened as shown. As soon as E received the ball, B cut toward the basket and circled in front of C where he received the ball from E. After passing the ball to B, E faked to the right and screened across court for D, who cut toward the right corner and around the pivot-block established by B. Waiting until D had cut around B, C retreated to the free-throw line. B has the option of attempting a shot, passing to D under the basket, or to C at the free-throw line.

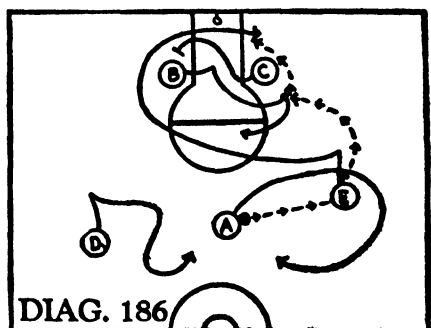
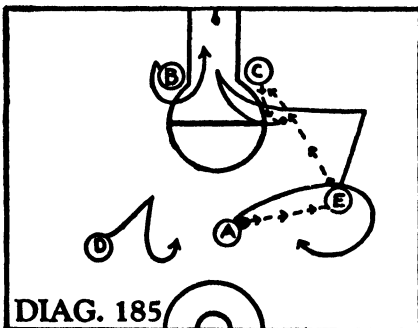

THE SET-SHOT PLAY: Diagram 185. A passed to E and screened as shown. As soon as E received the ball from A, he passed to C on the pivot, started to the right, changed direction, and cut toward the basket. When he saw his guard had cut behind C in an attempt to beat him to the basket, E threw a stop and retreated in front of C where he received the ball and attempted a side set-shot.

A PIVOT-BLOCK UNDER THE BASKET: Diagram 186. After receiving the ball from A and waiting for a screen, E passed the ball to B who had faked toward the basket and moved to a pivot position in front of C. E then started to the right, changed direction, and cut toward the left corner. C waited until B received the ball, then moved across the lane to establish a pivot-block. E cut by this position and received a return pass from B on the right side of the basket. Following his pass to E, B retreated to the free-throw line and waited for a return pass should E be guarded too closely to shoot.

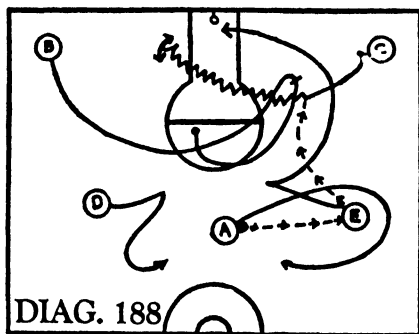
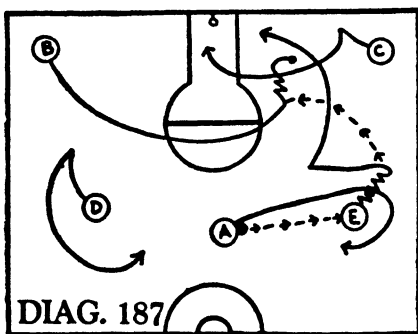

Lateral Pivots on the Side Lines

MOVING PIVOT PLAY: Diagram 187. E received the ball from A and dribbled a short distance toward the right corner. At the same time B cut across the free-throw circle to the ball. E threw the ball to B, started to the left, changed direction, and cut around the pivot-block which B had established on the right side of the basket. C waited until B had set up a block, faked to the right, changed direction, and cut to the left. B has the option of shooting or passing to E or to C.

PIVOT-BLOCK AND DRIBBLE: Diagram 188. A passed the ball to E. E completed the screen in front of his guard. B again broke across the court to a pivot position on the right side of the free-throw lane. C waited until B stopped, faked to the right, and cut in front of the pivot player where he received the ball from E. He then dribbled to the left side of the basket. Following his pass to C, E cut to the left, changed direction, and circled around B and toward the basket. As soon as E had passed by, B retreated to the free-throw line. Pivot player C has the option of shooting, passing to E under the basket, or to B at the free-throw line.

TRIPLE PIVOT ATTACK: This offense can be used when there are three pivot men on the squad who are so powerful that their under-basket scoring is difficult to stop. The two rear court players must be content to take care of

the defensive balance and confine their scoring to the use of the one-hand shot near the free-throw lane or to the medium length set-shot. Because of the follow-in power of the three pivot scorers, the rear court players can feel free to attempt medium and long shots.

The rear court players try to get the ball into the hands of the pivot players as quickly as possible. The best pass is to the corner pivot player who can break out a short distance to meet the ball. A number of screening plays are possible by the under-basket players. All three follow-in their own and rear court teammates' shots.

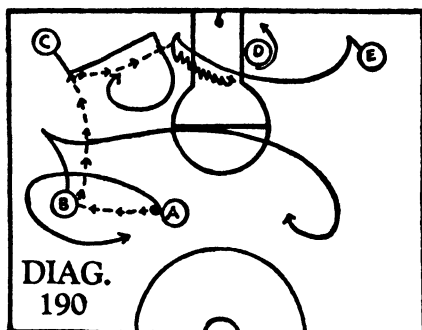
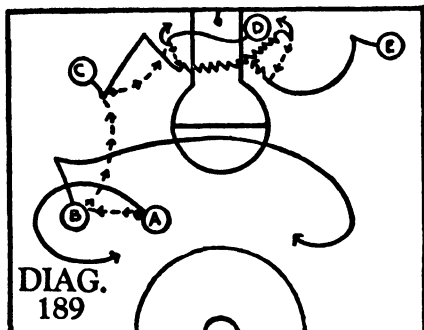

TRIPLE PIVOT ATTACK. PLAY 1: Diagram 189. A passed the ball to B, screened in front of the guard, and circled to the rear. B passed the ball to C, who advanced slightly to meet the pass. The under-basket pivot player D maintained his position until C received the ball and then broke across the lane to a pivot position on the left side of the basket. C passed D the ball, faked to the left, cut to the right, received a return pass, and dribbled hard to the right side of the basket. E cut from the right corner around C and toward the basket. This play is directed toward C's opponent. He is usually so much concerned about a possible pivot shot by C that he will not switch to E. If the guard switches, C will probably fake a pass and attempt a turn shot.

TRIPLE PIVOT ATTACK. PLAY 2: Diagram 190. A again passed to B and screened as shown. After C received the ball from B, E faked to the right and cut to the left side of the basket where he met C. C followed the pass and then reversed direction. E can attempt a shot. In the diagram he dribbled to his left and attempted a one-hand shot. All three pivot men followed-in.

TRIPLE PIVOT ATTACK. PLAY 3: Diagram 191. The ball was passed from A to C. D had been forced to a position on the left side of the lane, where he received the ball from C. After passing to D, C faked to the left and cut in front of the basket. If C succeeded in blocking his guard, D would pass him the ball. In this illustration D faked a pass to C, dribbled to the right side of the basket, and set up a pivot. He could shoot or pass to E. All three pivot men are expected to follow-in.

TRIPLE PIVOT ATTACK. PLAY 4: Diagram 192. B received the ball from A and passed it to C in the left corner. Teammate D had established a pivot position on the left side of the basket. E cut in front of D and received the ball

from C. After passing to E, C faked left and cut toward the free-throw circle. E passed the ball to C, faked to the right, cut to his left, and received a return pass from C in front of the basket. All three pivot players followed in the shot.

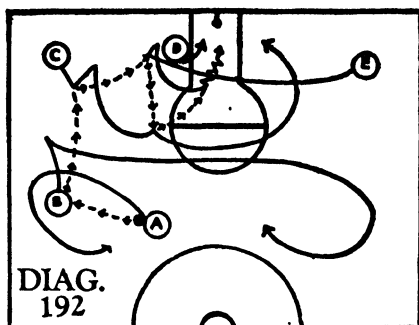
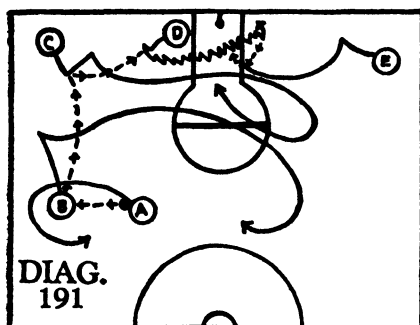

TRIPLE PIVOT ATTACK. PLAY 5: Diagram 193. A passed the ball to B and instead of circling toward the rear court continued in back of C and toward the basket. C broke out to a pass from B, received the ball, and passed it to D on the pivot. If A's guard was lost in the shuffle, D would feed the ball to him under the basket. Otherwise D might attempt a shot or pass the ball to C, who had cut to the free-throw line. E, the pivot player who was not engaged in the play, is expected to retreat to the rear court to assist B in establishing defensive balance.

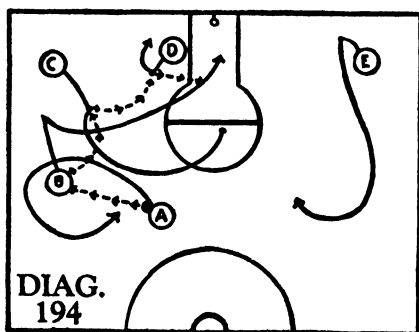
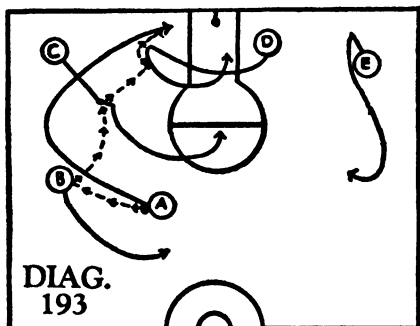

TRIPLE PIVOT ATTACK. PLAY 6: Diagram 194. A passed the ball to B and screened to the rear court. After passing the ball to C, B cut to the left, reversed direction, and drove toward the basket. D broke out to the pass and fed the ball to B. Here again the defensive guard may be delayed long enough to enable B to reach the basket unguarded. If D's opponent switches to guard B, D may attempt a shot or pass the ball to C, who has again moved to the free-throw line. E retreated to the rear court to help A establish defensive balance.

PUT THE BALL THROUGH THE HOOP

