

# Birla Central Library

PILANI (Jaipur State)

Engg College Branch

Class No :- 510-06

Book No :- D888M

Accession No :- 32245

## REQUEST

IT IS EARNESTLY DESIRED THAT THE BOOK  
BE HANDLED WITH CARE AND BE NOT MARKED  
UNDERLINED OR DISFIGURED IN ANY OTHER WAY  
OTHERWISE IT WILL HAVE TO BE REPLACED OR  
PAID FOR BY THE BORROWER IN THE INTEREST OF  
THE LIBRARY.

LIBRARIAN.





# MATHEMATICS FOR ENGINEERS

*The quality of the materials used in the manufacture  
of this book is governed by continued postwar shortages.*



# MATHEMATICS FOR ENGINEERS

BY

RAYMOND W. DULL

*Consulting Engineer; Member, American Society of Mechanical  
Engineers; Member, Western Society of Engineers*

SECOND EDITION  
SEVENTH IMPRESSION

McGRAW-HILL BOOK COMPANY, Inc.  
NEW YORK AND LONDON  
1941

MATHEMATICS FOR ENGINEERS

COPYRIGHT, 1926, 1941, BY THE  
MCGRAW-HILL BOOK COMPANY, INC.

PRINTED IN THE UNITED STATES OF AMERICA

*All rights reserved. This book, or  
parts thereof, may not be reproduced  
in any form without permission of  
the publishers.*

## PREFACE TO THE SECOND EDITION

The major change in this new edition, will be found in Chap. XVII on the slide rule, which adds several new rule operations made possible by the development of new and improved rules recently put on the market. Numerous changes of a minor nature have also been made throughout the text.

The author wishes to take this opportunity to thank many users of the book for their letters of appreciation and suggestions for the betterment of the book and particularly Professors Lyman M. Kells, Willis F. Kern, and James R. Bland, all of the United States Naval Academy, for helpful suggestions in the treatment of the slide rule.

RAYMOND W. DULL.

CHICAGO, ILL.,  
*January, 1941.*





## PREFACE TO THE FIRST EDITION

This treatise on mathematics has been prepared primarily for engineers. In this we would include (1) engineers who want a quick and convenient reference, (2) engineers who have grown somewhat rusty in their mathematics, and (3) engineers who feel the need of a text for the study of mathematics.

The two sources to which the engineer turns for mathematical aid are the engineer's handbook and the mathematical textbook. The former is too concise and incomplete because of the limited space available for this one subject. The latter is written to give mental training to students as well as mathematical knowledge. Intermediate steps are purposely omitted, knowledge of previous chapters is assumed, the time element of finding a solution is disregarded, and even important principles are left to the student to develop.

The author has, therefore, found it desirable in the course of his engineering practice to prepare his own notes on mathematics in order that he might have certain material available for quick reference. It was not his original intention to publish these notes but other engineers who examined them suggested that they should be made available in book form. Accordingly, the author undertook a thorough revision of his notes and made numerous additions which have resulted in the present work.

Considerable space is given to the treatment of absolute and relative errors, a subject not generally included in textbooks. Graphical solutions parallel the analytical solutions wherever possible, and illustrative problems are given for all important cases.

The slide rule is the engineer's assistant, and the fundamentals are discussed as if a rule were to be made. Instead of listing settings to be memorized, a set of simple rules is given to cover practically all cases. The start is made with the scale of equal parts, and the other scales are taken from it. This method is the opposite procedure from that given in textbooks.

Since this is a review, the viewpoint is taken that the different mathematical subjects are interlocked and should not be separated as in textbooks. As an illustration, the principles of the analytical geometry are applied in the algebraic sections, which makes the algebra clearer and the geometry more practical. An appeal is made for the use of the proportional divider, which the engineer uses to some extent, but which the textbook writer neglects altogether. The time element is fully discussed in the trigonometric section, because each year develops new phases of the periodic laws with which the engineer should be more familiar.

It is sincerely hoped that the calculus section will be helpful to many, and graphical methods are given considerable space to that end. The principle of the function of a function is applied much more fully than in textbooks, and the principle of the limit of the rate of change for the differential calculus and the setting up of the integral as the product of two variables, which can be represented by an area, should never be forgotten.

The author is indebted to Mr. Irving Metcalf for his assistance in the preparation of the manuscript, and to Professor Walter B. Carver of Cornell University, for kindly reading and making many helpful suggestions throughout the manuscript.

RAYMOND W. DULL.

CHICAGO, ILL.,  
*June, 1926.*

# CONTENTS

	PAGE
PREFACE TO THE SECOND EDITION. . . . .	v
PREFACE TO THE FIRST EDITION . . . . .	vii

## CHAPTER I

ART.	NUMERICAL COMPUTATIONS WITH ALGEBRAIC AIDS	
1.	Addition methods. . . . .	1
6.	Subtraction methods. . . . .	2
9.	Extended multiplication tables . . . . .	3
11.	Multiplication short cuts. . . . .	4
13.	Algebraic aids. . . . .	6
29.	Locating decimal point. . . . .	14
35.	Checking. . . . .	17
42.	Extracting roots. . . . .	19

## CHAPTER II

### APPROXIMATIONS. ABSOLUTE RELATIVE ERRORS

42.	Approximations. . . . .	21
54.	Errors in numbers. . . . .	23
56.	Errors in addition. . . . .	24
58.	Errors in multiplication . . . . .	26
65.	Errors in division . . . . .	34
71.	Errors in powers . . . . .	39
73.	Approximate forms . . . . .	42

## CHAPTER III

### ALGEBRAIC NOTATION. RATIO AND PROPORTION. BINOMIALS. TRINOMIALS. POLYNOMIALS. FACTORS AND MULTIPLES. RADICALS

80.	Algebraic notation. . . . .	44
81.	Ratio and proportion . . . . .	44
83.	The proportional divider. . . . .	46
84.	Binomials . . . . .	48
100.	Trinomials . . . . .	54
105.	Polynomials . . . . .	56
106.	Factors and multiples . . . . .	56
115.	Radicals. . . . .	61

## CHAPTER IV

FUNCTIONS AND GRAPHS AND THE STATEMENT OF PROBLEMS IN THE FORM  
OF EQUATIONS

ART.	PAGE
124. Functions and graphs . . . . .	66
129. Forming equations . . . . .	70
138. Commercial problems . . . . .	78

## CHAPTER V

LINEAR OR FIRST DEGREE EQUATIONS. ANALYTICAL AND GRAPHICAL  
SOLUTIONS

145. First degree problems . . . . .	83
150. Analytical solutions . . . . .	87
161. Graphical solutions . . . . .	92
167. Simultaneous linear equations. . . . .	97

## CHAPTER VI

QUADRATIC OR SECOND DEGREE EQUATIONS. EXPLICIT FUNCTIONS.  
ANALYTICAL AND GRAPHICAL SOLUTIONS

169. Explicit quadratic function of different forms with graphs . . .	99
177. Maximum and minimum quadratic functions. . . . .	108
181. Analytical methods of solution . . . . .	111
191. Geometrical solutions . . . . .	119
193. Other graphical solutions. . . . .	123

## CHAPTER VII

IMPLICIT QUADRATIC FUNCTIONS WITH GRAPHS. SIMULTANEOUS  
EQUATIONS

196. The implicit functions with graphs . . . . .	127
196. The parabola. . . . .	123
197. The circle . . . . .	129
200. The ellipse. . . . .	130
201. The hyperbola . . . . .	132
208. Shearing in the general quadratic equation. . . . .	139
211. Simultaneous quadratic equations. . . . .	145

## CHAPTER VIII

## FRACTIONS. FRACTIONAL EQUATIONS. IRRATIONAL EQUATIONS

223. Operations with fractions. . . . .	162
225. Fractional equations. . . . .	163
229. Irrational equations. . . . .	167

## CHAPTER IX

## CUBIC FUNCTIONS

231. Graphical cubic functions . . . . .	171
238. General cubic function. . . . .	177

ART.	PAGE
371. Logarithmic paper. . . . .	242
380. Changes in exponential functions . . . . .	249

## CHAPTER XVII

## THE SLIDE RULE

383. Description of fundamental scales. . . . .	251
397. Problems of various kinds . . . . .	257
407. Power scales . . . . .	263
410. Trigonometric scales. . . . .	264
415. General form problems. . . . .	267
422. Power factors. . . . .	272
424. Solution of triangles. . . . .	274

## CHAPTER XVIII

## INFINITE SERIES

430. Types of infinite series. . . . .	278
439. Comparison tests . . . . .	280
443. Ratio tests. . . . .	283
444. Cauchy's ratio tests. . . . .	284
454. Directions for testing series. . . . .	290
456. Power series . . . . .	291
457. Binomial series . . . . .	292
462. Exponential series. . . . .	296
464. Logarithmic series. . . . .	298

## CHAPTER XIX

## DETERMINANTS

465. Determinants of the second order. . . . .	299
468. Determinants of the third order. . . . .	300
475. Determinants of the $n$ th order . . . . .	304
476. Properties of determinants . . . . .	305

## CHAPTER XX

## PERMUTATIONS AND COMBINATIONS

490. Permutation arrangements. . . . .	310
495. The number of combinations . . . . .	312

## CHAPTER XXI

## UNDETERMINED COEFFICIENTS

496. Undetermined coefficients . . . . .	313
497. Development of fractions. . . . .	313
498. Development of surds . . . . .	315
499. Partial fractions. . . . .	315

## CHAPTER XXII

## GEOMETRY AND MENSURATION

504. Angular relations . . . . .	320
508. Formulae for triangles. . . . .	320

*CONTENTS*

xiii

Arr.	PAGE
528. Formulae for four sided figures . . . . .	324
533. Formulae for polygons. . . . .	326
537. Formulae for circle . . . . .	327
559. Formulae for conics . . . . .	332
564. Formulae for surfaces and solids. . . . .	334

CHAPTER XXIII

TRIGONOMETRIC FUNCTIONS

589. Angular magnitude . . . . .	340
594. Functions of angles . . . . .	342
604. Relations of functions of angles. . . . .	348

CHAPTER XXIV

GRAPHS OF TRIGONOMETRIC FUNCTIONS

607. Graphs of sine functions . . . . .	353
622. Graphs of cosine functions . . . . .	365
626. Damped oscillations. . . . .	367
627. Boundary curves . . . . .	367
629. The inverse trigonometric functions . . . . .	369
631. Graphs of tangent functions . . . . .	370
635. Graphs of other trigonometric functions . . . . .	372

CHAPTER XXV

TRIGONOMETRIC SOLUTION OF TRIANGLES

638. Solution of right triangles . . . . .	374
641. Solution of oblique triangles . . . . .	376

CHAPTER XXVI

POLAR COORDINATES

651. Polar coordinate with graphs. . . . .	383
655. Relation between polar and rectangular coordinates. . . . .	385
657. Time element in sine and cosine functions using polar coordinates	387

CHAPTER XXVII

VECTORS. IMAGINARY AND COMPLEX NUMBERS

660. Vectors . . . . .	390
662. Imaginary and complex numbers with graphs. . . . .	392
668. Vector representation of complex numbers . . . . .	395
674. Polar forms of complex numbers . . . . .	397
678. De Moivre's theorem and applications. . . . .	401

CHAPTER XXVIII

HYPERBOLIC FUNCTIONS

683. Hyperbolic functional relations . . . . .	406
687. Relations between the trigonometric and hyperbolic functions.	408
688. Hyperbolic functions in series. . . . .	408

## CHAPTER XXIX

ART.	SOLUTION OF TRIGONOMETRIC EQUATIONS	PAGE
690.	Algebraic solutions of trigonometric equations. . . . .	410
694.	Graphical solutions of trigonometric equations . . . . .	412
698.	Simultaneous trigonometric equations . . . . .	413

## CHAPTER XXX

## SIMPLE APPLICATION OF COORDINATES

701.	Line segments. . . . .	416
704.	Coordinates . . . . .	417
711.	Discussion of lines. . . . .	420
719.	Areas of triangles by coordinates . . . . .	424
723.	Areas of polygons by coordinates . . . . .	426
724.	Formation of equations . . . . .	426

## CHAPTER XXXI

## LINEAR EQUATIONS. THE STRAIGHT LINE

726.	Forms of linear equations . . . . .	429
737.	Polar equations of straight lines. . . . .	439
738.	System of straight lines . . . . .	439
743.	Product of two straight lines . . . . .	444

## CHAPTER XXXII

## SECOND-DEGREE EQUATIONS. CONICS. THE PARABOLA

745.	Conics . . . . .	446
748.	The parabola with graphs . . . . .	447
752.	General equation of the parabola . . . . .	450
756.	Parabolic problems . . . . .	452

## CHAPTER XXXIII

## THE CIRCLE AND THE ELLIPSE

758.	Equations of the circle. . . . .	454
761.	Systems of circles. . . . .	457
762.	Length of tangent. . . . .	458
763.	Equations of the ellipse . . . . .	459
772.	General form of equation of ellipse . . . . .	465
774.	Eccentric angle of ellipse. . . . .	467
775.	Equation of ellipse in polar coordinates . . . . .	468

## CHAPTER XXXIV

## THE HYPERBOLA

776.	Equations of the hyperbola. . . . .	469
786.	General form of equation of hyperbola. . . . .	477
787.	Polar equation of hyperbola . . . . .	478
788.	Relations of constants in equations of hyperbola . . . . .	478



## CHAPTER XXXV

ART.	DISCUSSION OF GENERAL SECOND-DEGREE EQUATION	PAGE
792.	Removal of first degree terms. . . . .	481
793.	Rotation of axes . . . . .	482
794.	Tests for type of conic. . . . .	483
796.	Tangents to conics . . . . .	484
798.	Normals to conics. . . . .	486
799.	Properties of conics . . . . .	486

## CHAPTER XXXVI

## PARAMETRIC AND POLAR EQUATIONS

803.	Parametric equations of various types . . . . .	492
806.	Examples of parametric equations. . . . .	497
815.	Polar equations. . . . .	502

## CHAPTER XXXVII

## EMPIRICAL EQUATIONS

826.	Linear functions. . . . .	506
831.	Power functions. . . . .	511
833.	Polynomial forms . . . . .	516
834.	Exponential forms. . . . .	516

## CHAPTER XXXVIII

## APPLICATION OF COORDINATES TO GEOMETRY OF THREE DIMENSIONS

835.	Coordinates of geometry of three dimensions . . . . .	519
838.	Angle between two lines . . . . .	521
840.	Surfaces . . . . .	522
846.	Projections. . . . .	525
849.	Surfaces of revolution . . . . .	527

## CHAPTER XXXIX

## LINEAR EQUATIONS IN THREE VARIABLES

856.	Equations of the plane. . . . .	531
861.	System of planes . . . . .	535
866.	Bisecting planes. . . . .	538
867.	Lines in space. . . . .	538

## CHAPTER XL

## SECOND-DEGREE EQUATIONS IN THREE DIMENSIONS

873.	The ellipsoid . . . . .	542
874.	The hyperboloid . . . . .	543
876.	The elliptic paraboloid. . . . .	546
877.	The hyperbolic paraboloid . . . . .	547
878.	The cone. . . . .	547
879.	The cylinder . . . . .	548
880.	Parametric equations of a curve in space. . . . .	549

## CHAPTER XLI

Art.	DIFFERENTIAL CALCULUS	Page
882.	Rates of change. . . . .	551
885.	Magnitude. . . . .	553
887.	Concept of a limit. . . . .	555

## CHAPTER XLII

## FUNDAMENTAL DIFFERENTIATION

889.	The derivative . . . . .	559
891.	Differentiation . . . . .	560

## CHAPTER XLIII

## DIFFERENTIATION OF ALGEBRAIC FUNCTIONS

897.	Differentiation of algebraic functions. . . . .	563
899.	Differentiation of a function of a function . . . . .	565
907.	Slope of the curve of general form. . . . .	572
908.	Implicit functions. . . . .	574
911.	Successive differentiation. . . . .	577
912.	Graphs of derivatives . . . . .	577
916.	Graphical differentiation. . . . .	581

## CHAPTER XLIV

## APPLICATION OF DIFFERENTIATION

919.	Newton's method of approximation . . . . .	584
920.	Discussion of motion. . . . .	586
931.	Miscellaneous problems with graphs. . . . .	597
935.	Force, mass and acceleration . . . . .	601

## CHAPTER XLV

## DIFFERENTIATION OF TRIGONOMETRIC FUNCTIONS

936.	The derivative of sine functions. . . . .	604
937.	The derivative of cosine functions. . . . .	606
943.	Simple harmonic motion. . . . .	610
945.	The derivative of tangent functions . . . . .	612
948.	The derivative of inverse trigonometric functions . . . . .	614
951.	The derivative of hyperbolic functions. . . . .	616

## CHAPTER XLVI

## DIFFERENTIATION OF LOGARITHMIC AND EXPONENTIAL FUNCTIONS

952.	Derivative of a logarithmic function. . . . .	618
952.	The Napierian base $e$ . . . . .	620
955.	Graphical comparison of curves. . . . .	622
956.	Derivative of exponential functions . . . . .	623
958.	Compound interest law . . . . .	625
959.	Graphical differentiation by use of exponential curve . . . . .	626

## CHAPTER XLVII

ART.	DIFFERENTIALS	PAGE
960.	Differential notation . . . . .	629
961.	Application of differentials . . . . .	630

## CHAPTER XLVIII

## CURVE ANALYSIS

964.	Parametric equations . . . . .	633
966.	Curve slopes . . . . .	634
970.	Curve concavity . . . . .	636
971.	Points of inflection . . . . .	638
972.	Maximum and minimum. . . . .	639
974.	Curvature . . . . .	645

## CHAPTER XLIX

## EXPANSION OF FUNCTIONS

976.	Rolle's Theorem. . . . .	647
977.	Law of the mean . . . . .	647
979.	Taylor's theorem with the remainder . . . . .	646
980.	Maclaurin's theorem with the remainder . . . . .	651
982.	Indeterminate forms. . . . .	653

## CHAPTER L

## PARTIAL AND TOTAL DIFFERENTIATION

983.	Functions of two independent variables . . . . .	657
984.	Partial differentiation . . . . .	657
985.	Total differentiation. . . . .	659
986.	Total differentiation of a function of a function. . . . .	661
987.	Successive partial differentiation . . . . .	662
989.	Total differentials. . . . .	665

## CHAPTER LI

## INTEGRAL CALCULUS

991.	Elementary forms. . . . .	666
997.	Areas by integration. . . . .	670

## CHAPTER LII

## GRAPHICAL INTEGRATION

1001.	Graphical method of integration. . . . .	678
1004.	Examples of graphical integration. . . . .	680
1007.	Graphs of intégral curves. . . . .	682

## CHAPTER LIII

## THE DEFINITE INTEGRAL

1011.	Integration between limits . . . . .	686
1013.	The mean ordinate . . . . .	687
1014.	Interchange of limits of integration . . . . .	688

ART.	PAGE
1015. Decomposing the limits of integration . . . . .	688
1016. Areas in parametric form. . . . .	689

## CHAPTER LIV

## REDUCTION METHODS FOR INTEGRATION

1017. Fundamental forms from differentiation . . . . .	690
1020. Integration by introduction of new variables . . . . .	691
1021. Integration by parts. . . . .	693
1022. Integration by transformation . . . . .	697
1023. Integration by inspection. . . . .	697
1025. Integration by the logarithmic form. . . . .	700
1027. Trigonometric reduction formulae. . . . .	703
1029. Integration of integrals containing fractional powers. . . . .	703
1030. Integration by trigonometric substitution. . . . .	703
1033. Integration of rational fractions. . . . .	705
1034. Integration by partial fractions. . . . .	705
1035. Successive integration . . . . .	706

## CHAPTER LV

## SUMMATION METHOD

1036. Summation theorem. . . . .	708
1037. Areas by summation method . . . . .	711
1039. Length of curve by summation method. . . . .	714
1041. Surfaces of revolution . . . . .	717
1043. Problems illustrating summation method. . . . .	719

## CHAPTER LVI

## EXAMPLES OF INTEGRATION

1046. Problems of belt drives. . . . .	723
1047. Law of cooling . . . . .	725
1048. Work done by an expanding gas. . . . .	725
1049. Equations of motion. . . . .	725
1051. Beam problems. . . . .	727
1055. Problems in mechanics. . . . .	734

## CHAPTER LVII

## PARTIAL AND MULTIPLE INTEGRATION

1063. Partial integration. . . . .	743
1066. Double integration . . . . .	746
1070. Examples of double integration. . . . .	753
1072. Centroids . . . . .	754
1073. Moment of inertia by double integration. . . . .	756
1076. Areas of surfaces by double integration. . . . .	759
1077. Volumes by triple integration. . . . .	761
1079. Summary of moments by summation method. . . . .	763
1080. Approximate methods of integration. . . . .	764
INDEX. . . . .	769

# MATHEMATICS FOR ENGINEERS

## CHAPTER I

### NUMERICAL COMPUTATIONS WITH ALGEBRAIC FORMULA AIDS

**1. Column Addition.**—In adding a column, as the unit column in the example, do not require your brain to say mentally, 2 plus 9 is 11, plus 7 is 18, etc., but mentally state the answer only of each addition, as

$$2 - 11 - 18 - 23 - 28 - 32.$$

Preferably place the sum of each column as shown rather than carry from one column to another, as errors are more easily corrected. In checking, start from the left column.

Place your answers on a separate piece of paper and transfer them to their proper places after checking.

8 7 4 2	
5 2 7 9	
8 2 6 7	
3 4 2 5	
8 7 6 5	
9 8 7 4	Check
3 2	4 1
3 2	3 0
3 0	3 2
4 1	3 2
4 4,3 5 2	4 4,3 5 2

**2. Banker's Method of Adding.**—In adding the column, the number is added in to each partial sum. This method does not require a second addition.

5 2 8 0	
9 7 6 0.5 0	
3 4 9	
4 0 0 6.7 5	
6 5 2 2.8 9	
1 3 2.1 2	
	1 6
	2 2
	2 1
	2 5
	2 0
2 6	
	2 6,0 5 1.2 6

$$\begin{array}{r}
 8 \\
 3 \\
 4 \\
 2. (17) = 10 + 7 \text{ make . carry } 7 \\
 6 \\
 1. (14) = 10 + 4 \text{ make . carry } 4 \\
 7 \\
 8. (19) = 10 + 9 \text{ make . carry } 9 \\
 5 \\
 3. (17) = 10 + 7 \text{ make . carry } 7 \\
 6 \\
 4. (17) = 10 + 7 \text{ make . carry } 7 \\
 7 (14) = \text{last sum} \\
 \underline{50} = 5 \text{ dots or } 5 \times 10 \\
 64 = \text{Ans.}
 \end{array}$$

**3. Period Addition.**—Add the numbers until their sum is just less than 20. Then make a period for 10 and add the excess over 10 to the next number, continuing as before.

**4. Mental Double-column Simultaneous Addition.**

Start with the first number (25) and alternately add, mentally, the units (as 6) and the tens (as 40) of each following number, rather than add both simultaneously; thus,

$$25 + 6, \quad 31 + 40, \quad 71 + 1, \quad 72, \text{ etc.}$$

Mentally state the answers only.

$$25 - 31 - 71 - 72 - 152 - 154 - 244 - 250 - 310.$$

**5. Mental three-column simultaneous addition** is done similarly to two-column addition (Art. 4) by following the tens' place addition by the hundreds' place figures. Thus, adding in the example:

$$237 - 241 - 301 - 1001 - 1002 - 1042 - 1542.$$

**6. Subtraction by Addition.**—Known as the Austrian or "making-change method." Put down as answer the number which must be added to the subtrahend to equal the corresponding number in the minuend, as in the example:

$$\begin{array}{r}
 6 + 7 \text{ is } 13 \quad \text{carry } 1 \\
 3 + 2 \text{ is } 5 \\
 7 + 2 \text{ is } 9 \\
 8 + 9 \text{ is } 17 \\
 \hline
 17953 \\
 8726 \\
 \hline
 -9227
 \end{array}$$

The numbers in heavy-faced type are the only ones put down.

**7. Subtraction by Complements.**

From 27 take 8.

The complement of 8 is 2.

If both numbers are increased by this number, the subtraction is easier.

$$\begin{array}{r} 27 + 2 = 29 \\ 8 + 2 = 10 \\ \hline 19 \end{array}$$

From 173 take 94.

$$173 - 94 = (173 + 6) - (94 + 6) = 179 - 100 = 79.$$

**8. Combined Addition and Subtraction.**

If a column of numbers consists of some numbers to be added, and others to be subtracted, one method is to find the sum of the positive numbers, and then the sum of the negative numbers. Then find their difference.

The other method is to add and subtract, as you proceed down each column.

$$\begin{array}{r} 7483 \\ 4829 \\ - 3182 \\ - 6334 \\ 8371 \\ - 1217 \\ \hline + 20683 \\ - 10733 \\ \hline 9950 \end{array}$$

**9. Rapid Multiplication.**—To learn the multiplication table through the teens is helpful.

**MULTIPLICATION TABLES EXTENDED**

<b>13</b> × 1 = 13	<b>14</b> × 1 = 14	<b>15</b> × 1 = 15	<b>16</b> × 1 = 16
2 = 26	2 = 28	2 = 30	2 = 32
3 = 39	3 = 42	3 = 45	3 = 48
4 = 52	4 = 56	4 = 60	4 = 64
5 = 65	5 = 70	5 = 75	5 = 80
6 = 78	6 = 84	6 = 90	6 = 96
7 = 91	7 = 98	7 = 105	7 = 112
8 = 104	8 = 112	8 = 120	8 = 128
9 = 117	9 = 126	9 = 135	9 = 144
10 = 130	10 = 140	10 = 150	10 = 160
11 = 143	11 = 154	11 = 165	11 = 176
12 = 156	12 = 168	12 = 180	12 = 192
13 = 169	13 = 182	13 = 195	13 = 208
	14 = 196	14 = 210	14 = 224
		15 = 225	15 = 240
			16 = 256

## MULTIPLICATION TABLES EXTENDED.—(Continued)

$17 \times 1 = 17$	$18 \times 1 = 18$	$19 \times 1 = 19$
$2 = 34$	$2 = 36$	$2 = 38$
$3 = 51$	$3 = 54$	$3 = 57$
$4 = 68$	$4 = 72$	$4 = 76$
$5 = 85$	$5 = 90$	$5 = 95$
$6 = 102$	$6 = 108$	$6 = 114$
$7 = 119$	$7 = 126$	$7 = 133$
$8 = 136$	$8 = 144$	$8 = 152$
$9 = 153$	$9 = 162$	$9 = 171$
$10 = 170$	$10 = 180$	$10 = 190$
$11 = 187$	$11 = 198$	$11 = 209$
$12 = 204$	$12 = 216$	$12 = 228$
$13 = 221$	$13 = 234$	$13 = 247$
$14 = 238$	$14 = 252$	$14 = 266$
$15 = 255$	$15 = 270$	$15 = 285$
$16 = 272$	$16 = 288$	$16 = 304$
$17 = 289$	$17 = 306$	$17 = 323$
	$18 = 324$	$18 = 342$
		$19 = 361$

**10. How to Make Change.***First.* Name the cost of goods.*Second.* Add enough to make even money.*Third.* Add the large coins.

EXAMPLE.—The cost of the article is 33 cents. The customer gives 50 cents.

*First.* Think of 33.*Second.* Add 2 making 35.*Third.* Add 5 making 40.*Fourth.* Add 10 making 50.**11. Other Short Cuts.****To multiply by  $.02\frac{1}{2}$ ,** point off one place and divide by 4.**To multiply by  $.03\frac{1}{3}$ ,** point off one place and divide by 3.**To multiply by  $.05$ ,** point off one place and divide by 2.**To multiply by  $.07\frac{1}{2}$ ,** point off one place and deduct  $\frac{1}{4}$  of that result.**To multiply by  $.11\frac{1}{2}$ ,** point off one place and add  $\frac{1}{2}$  of that result.**To multiply by  $.13\frac{1}{3}$ ,** point off one place and add  $\frac{1}{3}$  of that result.



**To multiply by  $.13\frac{3}{4}$ ,** point off one place and add  $\frac{1}{4}$  of result, plus  $\frac{1}{2}$  of  $\frac{1}{4}$ , or  $\frac{1}{2}$  of that result.

**To multiply by .18.**

$.18 = .20 - .02 = \frac{1}{5} - \frac{1}{50}$  of  $\frac{1}{5}$ . Hence, divide by 5 and then subtract  $\frac{1}{50}$  of that result.

**To multiply by  $.23\frac{1}{3}$ .**

$.23\frac{1}{3} = .20 + .03\frac{1}{3} = \frac{1}{5} + \frac{1}{3}$  of result. Therefore, divide by 5 and add  $\frac{1}{3}$  of that result.

**To multiply by .24.**

$.24 = .25 - .01 = \frac{1}{4} - .01$ . Therefore, divide by 4 and subtract .01 of number.

**To multiply by  $.27\frac{1}{2}$ .**

$.27\frac{1}{2} = .25 + .025 = \frac{1}{4} + \frac{1}{40}$  of  $\frac{1}{4}$ . Therefore, divide by 4 and add  $\frac{1}{40}$  to that result.

**To multiply by .45.**

$.45 = .50 - .05 = \frac{1}{2} - \frac{1}{20}$  of  $\frac{1}{2}$ . Divide by 2 and subtract  $\frac{1}{20}$  of that result.

**To multiply any number by 25,** add two ciphers and divide by 4.

**To multiply any number by 75,** add two ciphers, divide by 4, and then multiply result by 3.

**To multiply any number by 125,** add three ciphers and divide by 8.

**To multiply any number by 250,** add three ciphers and divide by 4.

*Conversely:*

**To divide any number by 25,** point off two places and multiply by 4.

**To divide any number by 75,** point off two places, multiply by 4, and then divide result by 3.

**To divide any number by 125,** point off three places and multiply by 8.

**To divide any number by 250,** point off three places and multiply by 4.

**12. Arithmetical processes** can often be simplified by using algebraic relations of the numbers, rather than by a long rule. Rules are hard to remember and the process is not always clear.

The application of a few algebraic equations will be shown in the following articles.

**13. To Square Numbers Ending in 5.**—Consider a number consisting of units and tens only, or a number of the second order.

Let  $a$  = the number in tens' column.

5 = the number in units' column.

Then

$(10a + 5)$  = the number.

$$\begin{aligned}(10a + 5)^2 &= 100a^2 + 100a + 25. \\ &= 100a(a + 1) + 25.\end{aligned}$$

Therefore, if we multiply the figure in the tens' place by itself increased by 1 and then place 25 following this product, a number will be obtained which is the square of the original number.

EXAMPLE.—Square 35 mentally.

$$\begin{array}{r}100 \times 3 \times 4 = 1200 \\ \text{Adding } 25 \qquad \qquad 25 \\ \hline 1225\end{array}$$

In actual practice do not multiply by 100, but let the 25 occupy the two cipher places and simply put down 1225 in your mind.

The advantage of knowing the multiplication table through the teens will be evident in the following example:

EXAMPLE.—Square 145 mentally.

$$\begin{array}{r}14 \times (14 + 1) = 14 \times 15 = 210 \\ \text{Adding } 25 \qquad \qquad \qquad 25 \\ \hline 21025\end{array}$$

In this case we have assumed that there are 14 units in the tens' column

**14. To square any number ending in  $\frac{1}{2}$ ,** say  $(n + \frac{1}{2})$ , simply multiply the integer  $n$  by the next higher integer and add  $\frac{1}{4}$ .

Thus,

$$\begin{aligned}(7\frac{1}{2})^2 &= (7 \times 8) + \frac{1}{4} = 56\frac{1}{4}. \\ (10\frac{1}{2})^2 &= 110\frac{1}{4} \text{ (see Art. 13).}\end{aligned}$$

**15. To square a number near 50,** find its excess over 50, add this to 25 to get the hundreds; and then add the square of the excess, as

$$\begin{aligned}(56)^2 &= (25 + 6) + 6^2 = 3136. \\ (53)^2 &= (25 + 3) + 3^2 = 2809.\end{aligned}$$

For

$$(50 + a)^2 = 2500 + 100a + a^2 = (25 + a) \times 100 + a^2.$$

If the number is less than 50, find the difference between it and 50. Subtract this difference from 25 to determine the hundreds, and add the square of this difference to the result.

Thus,  $(47)^2 = (25 - 3) + 3^2 = 2209.$   
 $(41)^2 = (25 - 9) + 9^2 = 1681.$

**16. To Find the Product of Two Numbers, if Both End in 5, and the Tens' Figures are Both Even or Both Odd.**

Let  $a$  = the figure in tens' column in first number.

$b$  = the figure in tens' column in second number.

Then  $(10a + 5)$  = the first number.

$(10b + 5)$  = the second number.

$$(10a + 5)(10b + 5) = 100ab + 50b + 50a + 25.$$

That is,

$$100ab = a \times b \times 100.$$

And

$$50a + 50b = \frac{a + b}{2} \times 100.$$

Therefore, the product equals a half of the sum of the tens' figures added to their product with 25 appended in place of two ciphers. Note, however, that  $a$  and  $b$  must be both even or both odd, or their sum is not exactly divisible by 2, and this rule will not apply unless this is the case.

EXAMPLE.—Find mentally the product of  $65 \times 45$ .

$$\begin{array}{r} \frac{6 + 4}{2} = 5 \\ 6 \times 4 = 24 \\ \text{Sum} \quad \quad \quad \underline{29} \\ \text{Appending} \quad \quad \underline{25} \\ 2925 = \text{Ans.} \end{array}$$

EXAMPLE.—Find mentally the product of  $175 \times 195$ .

$$\begin{array}{r} \frac{17 + 19}{2} = 18 \\ 17 \times 19 = 323 \\ \text{Sum} \quad \quad \quad \underline{341} \\ \text{Appending} \quad \quad \underline{25} \\ 34125 = \text{Ans.} \end{array}$$



ALGEBRAIC FORMS APPLICABLE TO MULTIPLICATION

18. Form  $a(b - c)$ .—Expanded, this is equivalent to  $ab - ac$ .

EXAMPLE.—Multiply  $945 \times 998$ .

$$\begin{aligned} 945 \times 998 &= 945 \times (1000 - 2). \\ &= 945,000 - (945 \times 2). \\ &= 945,000 - 1890 = 943,110. \end{aligned}$$

19. Form  $a(cb + c) = acb + ac$ .

EXAMPLE.—Multiply  $384 \times 246$ .

$$\begin{aligned} \text{Therefore, } 246 &= (6 \times 40) + 6. \\ 384 \times 246 &= 384[(6 \times 40) + 6] \\ 384 \times 6 &= 2304 \text{ and } 2304 \times 40 = 92,160. \\ 92,160 + 2304 &= 94,464. \text{ Ans.} \end{aligned}$$

A more convenient form is to multiply first by 6 and then multiply that product by 40, as

$$\begin{array}{r} 384 \\ 246 \\ \hline 2304 \\ 40 \times 2304 = 9216 \\ \hline 94,464 \end{array}$$

20. Form  $ab = ba$ .—Thus, 89 per cent of \$25 is the same as 25 per cent of \$89, which is the same as one-fourth of \$89.

21. Form  $(a + b)(a - b) = a^2 - b^2$ .

EXAMPLE.—Calculate mentally  $52 \times 48$ .

Comparing with formula,

$$(50 + 2)(50 - 2) = 50^2 - 2^2 = 2500 - 4 = 2496.$$

Note that we square the arithmetic mean for  $a^2$  and the common difference for  $b^2$ .

EXAMPLE.—Multiply  $75 \times 65$ .

$$(70 + 5)(70 - 5) = 4900 - 25 = 4875.$$

EXAMPLE.

$$97 \times 103 = (100 + 3)(100 - 3) = 9991.$$

EXAMPLE.

$$31 \times 29 = (30 + 1)(30 - 1) = 900 - 1 = 899.$$

The reverse order can also be used when the difference between two squares is given, and we wish to know the numbers.

**EXAMPLE.**—Find  $81^2 - 62^2$ .

Here,  $a = 81$ , and  $b = 62$ .

$$(a - b)(a + b) = 19 \times 143 = 2717.$$

This formula is convenient if the hypotenuse and one side of a right triangle are given and it is desired to find the other side. Thus, letting

$a$  = the length of the hypotenuse,  
 $b$  = the length of the known side, and  
 $x$  = the length of the unknown side,

it is evident that,

$$x = \sqrt{a^2 - b^2} = \sqrt{(a + b)(a - b)}.$$

**EXAMPLE.**—A triangle (right) has a hypotenuse whose length is 5 and another side whose length is 3. Find the length of the remaining side.

$$x = \sqrt{5^2 - 3^2} = \sqrt{(5 + 3)(5 - 3)} = \sqrt{8 \times 2} = 4.$$

**22. Forms**  $(a + b)^2 = a^2 + 2ab + b^2$ .

$$(a - b)^2 = a^2 - 2ab + b^2.$$

**EXAMPLE.**—Square 54 mentally.

$$\begin{aligned} 54^2 &= (50 + 4)^2 = 50^2 + (2 \times 50 \times 4) + 4^2 \\ &= 2500 + 400 + 16 = 2916. \end{aligned}$$

**EXAMPLE.**—Square 49 mentally.

$$\begin{aligned} 49^2 &= (50 - 1)^2 = 50^2 - (2 \times 50 \times 1) + 1^2 \\ &= 2500 - 100 + 1 = 2401. \end{aligned}$$

**23. Form**  $(a + b)(a + c) = a^2 + (b + c)a + bc$ .

**EXAMPLE.**—Multiply  $121 \times 126$  mentally.

$$(120 + 1)(120 + 6) = 14,400 + (7 \times 120) + 6 = 14,400 + 840 + 6 = 15,246.$$

If problems like this cannot be solved mentally, a saving of time will be made by using this method.

**EXAMPLE.**—Multiply  $76 \times 81$ .

$$(80 + 1)(80 - 4) = 6400 - 240 - 4 = 6156.$$

Or, in this manner,  $(70 + 6)(70 + 11) = 4900 + 1190 + 66 = 6156$ .

Note that in this case the tens' figures must be the same in both numbers. The product of the two numbers, if the tens are alike, is the sum of the square of the tens, the product of the tens by the sum of the units, and the product of the units.

**24. Form**  $(a + b)(c + b) = ac + (a + c)b + b^2$ .—Note that the units' figures are alike.

EXAMPLE.—Multiply  $42 \times 72$  mentally.

$$\begin{array}{rcl} ac & = 40 \times 70 & = 2800 \\ (a + c)b & = (40 + 70) \times 2 & = 220 \\ b^2 & = 2 \times 2 & = 4 \\ & & \hline & & 3024 \end{array}$$

The product of two numbers, if the units' figures are alike, is the sum of the square of the units, the product of the units by the sum of the tens, and the product of the tens. Compare this rule to Art. 23 and note the difference.

**25. Form  $(a + b)(c + d) = ac + bc + ad + bd$ .**—The product of two numbers is the sum of the product of the units, the product of the tens, and the cross-products of the units by the tens.

Put down the product of the units (12) and, just beyond, the product of the tens (72); 27 and 32 are the cross-products of the units by the tens and should be placed in tens' and hundreds' columns. Note that it is unnecessary to carry any figures.

$$\begin{array}{r} 83 \\ 94 \\ \hline 7212 \\ 27 \\ 32 \\ \hline 7802 \end{array}$$

Bear in mind that two places must be reserved for the product of the units, and in case their product is less than 10, a cipher should be added to fill the second place, as

$$\begin{array}{r} 84 \\ 62 \\ \hline 4808 \\ 24 \\ 16 \\ \hline 5208 \end{array}$$

Use the multiplication tables of the teens thus:

$$\begin{array}{r} 143 \\ 186 \\ \hline 25218 \\ 84 \\ 54 \\ \hline 26,598 \end{array}$$

$$\begin{array}{l} 3 \times 6 = 18 \qquad 14 \times 18 = 252 \\ 6 \times 14 = 84 \\ 3 \times 18 = 54 \end{array}$$

In case you do not know these multiplication tables, this same form can be used to advantage.

1 4	1 5	1 6	1 8	1 9
<u>1 2</u>	<u>1 5</u>	<u>1 7</u>	<u>1 9</u>	<u>1 9</u>
108	125	142	172	181
<u>6</u>	<u>10</u>	<u>13</u>	<u>17</u>	<u>18</u>
168	225	272	342	361

This operation can be resolved into a very simple rule: Add 100 to the product of the units, and then add the sum of the units moved one place to the left.

**26. To Multiply by 21, 31, 41, Etc., or by 401, 601, Etc.**

**EXAMPLE.**—Multiply 287 by 41.

$287 \times 4 = 1148.$	Add 287 to this, just as it stands, without multiplying by 1. After a little practice, the minuend can be added while the multiplication by the tens progresses. The 7 would be written first and the 8 would be added to the product of $4 \times 7$ , etc.
$\begin{array}{r} 287 \\ 41 \\ \hline 1148 \\ \hline 11,767 \end{array}$	

**EXAMPLE.**—Multiply  $458 \times 601$ .

$\begin{array}{r} 458 \\ 601 \\ \hline 275,258 \end{array}$	Put down 58 at once. Multiply through by 6, adding in the 4 as you go.
---	---

**27. The Supplement and Complement Method of Multiplication.**

**EXAMPLE.**—Multiply  $107 \times 104$ .

The supplements are 7 and 4, respectively.

*First.* Take the product of the supplements  $7 \times 4 = 28$  for the last two figures of the result.

*Second.* Add either supplement to the other number and write the sum as the other part of the answer.

$$107 + 4 = 111.$$

Therefore,

$$11,128 = \text{Ans.}$$

**EXAMPLE.**—Multiply  $97 \times 96$ .

The complements are 3 and 4.

*First.* Take the product of the complements for the last figures of the answer,  $3 \times 4 = 12$ .

*Second.* Deduct either complement from the other number to get the remaining part of the answer,  $96 - 3 = 93$ . Therefore, the answer is 9312.



**28. Aliquot Parts.**—An aliquot part of a number is a number that is contained in the larger number an integral number of times.

Thus,  $25 = \frac{1}{4}$  of 100,  $10 = \frac{1}{5}$  of 50.

A convenient use of aliquot parts in computing is as follows:

16 hours' labor at 25 cents.

25 cents is  $\frac{1}{4}$  of \$1.  $16 \times \frac{1}{4} = \$4$ .

60 hours' wages at 75 cents.

75 cents is  $\frac{3}{4}$  of \$1.  $60 \times \frac{3}{4} = \$45$ .

If very much work is done similar to that shown above, it is convenient to know the aliquot parts as shown in the following table:

48 hours at  $18\frac{3}{4}$  cents is  $\frac{3}{8}$  of 48 or \$9.

Payrolls, trade discounts, etc., can be worked this way. Engineers also should know without hesitation the relations of the sixteenths and eighths because of measurements taken in these units. The table of twelfths is also very convenient and is given below.

$\frac{1}{16}$				$6\frac{1}{2}$
	$\frac{1}{8}$			$12\frac{1}{2}$
$\frac{1}{8}$				$18\frac{3}{4}$
		$\frac{1}{4}$		25
$\frac{1}{4}$				$31\frac{1}{2}$
	$\frac{3}{8}$			$37\frac{1}{2}$
$\frac{3}{8}$				$43\frac{1}{4}$
			$\frac{1}{2}$	50
$\frac{1}{2}$				$56\frac{1}{2}$
	$\frac{5}{8}$			$62\frac{1}{2}$
$\frac{5}{8}$				$68\frac{1}{2}$
		$\frac{3}{4}$		75
$\frac{3}{4}$				$81\frac{1}{2}$
	$\frac{7}{8}$			$87\frac{1}{2}$
$\frac{7}{8}$				$93\frac{1}{2}$

$\frac{1}{12}$					$8\frac{1}{3}$
	$\frac{1}{6}$				$16\frac{2}{3}$
		$\frac{1}{4}$			25
			$\frac{1}{3}$		$33\frac{1}{3}$
$\frac{5}{12}$					$41\frac{2}{3}$
				$\frac{1}{2}$	50
$\frac{7}{12}$					$58\frac{1}{3}$
			$\frac{2}{3}$		$66\frac{2}{3}$
	$\frac{3}{4}$				75
	$\frac{5}{6}$				$83\frac{1}{3}$
$\frac{11}{12}$					$91\frac{2}{3}$

50 cents -  $8\frac{1}{3}$  cents =  $\frac{1}{2} - \frac{1}{12} = \frac{5}{12} = 41\frac{2}{3}$  cents.

\$1 -  $41\frac{2}{3}$  cents =  $1 - \frac{5}{12} = \frac{7}{12} = 58\frac{1}{3}$  cents.

$16\frac{2}{3}$  cents +  $58\frac{1}{3}$  cents =  $\frac{1}{3} + \frac{7}{12} = \frac{3}{4} = 75$  cents.

60 yards of tile at  $91\frac{2}{3}$  cents =  $\frac{1}{12}$  of \$60 = \$5.

\$120 at  $16\frac{2}{3}$  per cent discount =  $120 - \frac{1}{6}$  of 120 =  $120 - 20 =$   
\$100.

Interest on \$240 at  $8\frac{1}{3}$  per cent for 1 year.  $\frac{1}{12}$  of \$240 = \$20.

**29. Locating the Decimal Point.**—The decimal point should be located by inspection. If the old method is used, considerable difficulty will result, if short-cut methods are adopted, or the slide rule used.

**EXAMPLE.**—Multiply  $4652 \times 3.1416$ .

Note that the answer will be a little over three times the multiplicand, and in this case will contain five figures to the left of the decimal point.

If the multiplier is 3141.6, think of it as 3 with the point moved three places to the right;  $3 \times 4652$  would have five figures plus three ciphers, giving eight places to the left of the decimal point.

If the multiplier is 0.000031416, think of it as 3 with the decimal point moved six places to the left;  $3 \times 4652$  would have five figures, but shifting the point back six places gives one cipher before the first significant figure.

**30. Position of Decimal Point in Division.**—In fractional division, shift the decimal point (mentally) in the denominator to the location directly following the first significant figure. Then move the decimal point in the numerator or the dividend the same number of places and in the same direction as it has been moved in the denominator or divisor. Locate the decimal point by inspection.

**EXAMPLES.**

$$\frac{2.717}{31416} = \frac{.0002717}{3.1416} = \text{about } .00009$$

.0000865 = *Ans.*

$$\frac{31.416}{0.002717} = \frac{31416}{2.718} = \text{about } 10,000$$

11,558 = *Ans.*

**31. If an expression involves multiplying and dividing several numbers,** the decimal point is hard to locate, without a special device for that purpose. It is advisable to examine the problem to determine the decimal point before proceeding with the indicated operations, for approximations can often be made of the numbers, and the work simplified.

In order to determine the decimal point, as well as the approximate value, break up each number into two factors; one factor, the first left-hand figure, set as a whole number occupying units' place, and a second factor of 10, raised to a power which makes the product of the two factors equal to the number.

Thus,  $4000 = 4.000 \times 10 \times 10 \times 10 = 4 \times 10^3$ . Or again,  
 $523 = 5.23 \times 10^2$ .

*The exponent of 10 is equal to the number of decimal places through which the point has been shifted.* If the point is shifted three places to the left, as in the example, and the 4 made the only whole number, the exponent is positive, and if shifted two places to the right ( $.04 = 4 \times 10^{-2}$ ), the exponent is negative, or minus 2.

In the same manner, if a 10 with an exponent is in the denominator, it can be shifted to the numerator by changing the sign of the exponent.

$$\begin{aligned} 10 &= 1 \times 10^1 & \frac{1}{10} &= 1 \times \frac{1}{10} = 1 \times 10^{-1} \\ 200 &= 2 \times 10^3 & \frac{1}{100} &= 1 \times \frac{1}{10^2} = 1 \times 10^{-2} \\ 3000 &= 3 \times 10^3 & \frac{1}{.1} &= 1 \times \frac{1}{10^{-1}} = 1 \times 10^1 \\ .1 &= 1 \times 10^{-1} & \frac{1}{.02} &= \frac{1}{2} \times \frac{1}{10^{-2}} = \frac{1}{2} \times 10^2 \\ .01 &= 1 \times 10^{-2} \\ .001 &= 1 \times 10^{-3} \end{aligned}$$

**32. Applying the devices of Art. 31 to the following example:**

EXAMPLE.

$$\frac{22684 \times .0713}{.00189 \times 83 \times 6} = \frac{(2 \times 10^4)(7 \times 10^{-2})}{(2 \times 10^{-3})(8 \times 10)(6)}$$

Separating the 10 factors from the others, which, of course, we would do in practice, without the above explanatory intermediate step, we have

$$\begin{aligned} \frac{2 \times 7}{2 \times 8 \times 6} \times 10^{4-2+3-1}, \text{ or canceling the 2s.} \\ \frac{7}{48} \times 10^4 = \frac{7}{4.8} \times 10^3 = 1.459 \times 10^3 = 1459. \end{aligned}$$

This locates the decimal point. We now know very nearly what the answer should be and can readily arrange our approximations of each number, in case we wish a more accurate result.

EXAMPLE.

$$\frac{4.89 \times 986}{373 \times .07 \times 472} = \frac{5 \times 1}{4 \times 7 \times 5} \times 10^{3-2+2-2} = \frac{1}{2.8} = 0.36.$$

**33. Division.**—We were taught in our childhood days to assume a trial quotient by inspecting the first left-side figure of the divisor and the left side of the dividend to find the number of times the former is contained in the latter. The multiplication is often completed only to find that the quotient assumed was too large.

If the precaution is taken to see what remainder is carried, when the trial quotient is multiplied by the *second* figure of the divisor and added to the product of the quotient by the first divisor figure, the amount gives a better comparison to the figures of the dividend.

Compare the old method to the new, as

$$\underline{2456} | 113,344 | \underline{5}$$

By the old method we are likely to try 5, as 2 seems to go into 11, but if we multiply 4 (second number of divisor) by 5, we have 2 to carry, which added to  $5 \times 2$  equals 12. This shows at once that 5 is too large and we take 4 instead.

**34. Division by Factors.**—Separate the divisor into factors and perform by short division, mentally if possible, putting down the answers only.

**EXAMPLE.**—Divide 504 by 42.

Factors of 42 are 2, 3, and 7, or 6 and 7.

$$\begin{array}{r} 2 \overline{) 504} \\ 3 \overline{) 252} \\ 7 \overline{) 84} \\ \hline 12 = \text{Ans.} \end{array}$$

or

$$\begin{array}{r} 6 \overline{) 504} \\ 7 \overline{) 84} \\ \hline 12 = \text{Ans.} \end{array}$$

Or reduce both dividend and divisor to factors and suppress the common factors.

**EXAMPLE.**

$$2 \overline{) 504} = 2 \times 2 \times 2 \times 3 \times 3 \times 7$$

$$2 \overline{) 252}$$

$$2 \overline{) 126}$$

$$3 \overline{) 63}$$

$$3 \overline{) 21}$$

$$7$$

$$2 \overline{) 42}$$

$$3 \overline{) 21}$$

$$7$$

The remaining factors in the dividend are

$$2 \times 2 \times 3 = 12. \text{ Ans.}$$

This last process is not always a saving of time but usually contributes to greater accuracy.

CHECK OF NINES

**35. Addition.**—Add the figures forming the numbers, divide by 9, and compare the sum of the remainders with the remainder of the answer.

EXAMPLE.	3 4 4 8	$\frac{3 + 4 + 4 + 8}{9} = \frac{19}{9} = 1$	remainder.
	7 1 2 8		
	8 8 7 3	$\frac{7 + 1 + 2 + 8}{9} = \frac{18}{9} = 0$	remainder.
	4 1 2 3		
	2 2	$\frac{8 + 8 + 7 + 3}{9} = \frac{26}{9} = 8$	remainder.
	1 5		
	1 4	$\frac{4 + 1 + 2 + 3}{9} = \frac{10}{9} = 1$	remainder.
	2 2		
	2 3 5 7 2		$\frac{10}{9} = 1$ remainder.
	2 + 3 + 5 + 7 + 2	$= \frac{19}{9} = 1$	remainder.

**36. Subtraction.**—Consider the minuend as the sum of the subtrahend and the remainder, and proceed as in addition.

EXAMPLE.	4 8 2 9	$4 + 8 + 2 + 9 = 5$	remainder.
	3 3 4 7	$3 + 3 + 4 + 7 = 8$	remainder.
	1 4 8 2	$1 + 4 + 8 + 2 = 6$	remainder.
	$\frac{8 + 6}{9} = 5$		remainder.

**37. Multiplication.**—Find the remainders in multiplicand and multiplier, and then find the remainder of the product of their remainders, which should equal the remainder of the product of the two numbers.

EXAMPLE.	3 6 5	5	
	$\frac{5 6}{2 1 9 0}$	$\frac{2}{10}$	remainder = 1.
	$\frac{1 8 2 5}{2 0 4 4 0}$		$2 + 0 + 4 + 4 + 0 = 10$ , or remainder = 1.

**38. Division.**—Consider the dividend as being the product of the quotient and the divisor, and proceed as in multiplication.

**39.** A short cut can be made in using the 9 check as follows: Take 2,689,143, the sum of the numbers, which, when divided by 9, equals  $33 \div 9$ , which gives a remainder of 6.

Add the numbers, then add the figures of the result, or  $3 + 3 = 6$ , and obtain the remainder direct instead of dividing 33 by 9 and finding the remainder.

**40. Another short cut** is to cancel all figures which total 9.

Take the number 2,689,143, and combine  $6 + 3$ ,  $8 + 1$ , 9; and the remaining figures are 2 and 4, whose sum 6 is the remainder.

### FACTORING

**41.** All even numbers are divisible by 2.

A number is divisible by 3 if the sum of its digits is divisible by 3.

EXAMPLE.—4782.  $4 + 7 + 8 + 2 = 21$ , which is divisible by 3. Therefore, 4782 is divisible by 3.

A number is divisible by 4 if it ends in two ciphers or in two digits forming a number divisible by 4.

A number ending in 0 or 5 is divisible by 5.

An *even* number is divisible by 6 if the sum of the digits is divisible by 3.

7, 11, 13 will divide 1001, or any of its multiples, as 5005, 8008, 12,012, etc.

A number is divisible by 8 if it ends in three ciphers, or in three digits forming a number divisible by 8, as 125,000 or 164,896.

A number is divisible by 9 if the sum of its digits is divisible by 9.

A number ending in 0 is divisible by 10.

A number is divisible by 25 if it ends in two ciphers or in two digits forming a multiple of 25.

A number is divisible by 125 if it ends in three ciphers or in three digits forming a multiple of 125.

A factor of a number is also a factor of all multiples of that number.

A common factor of two numbers is a factor also of the sum, or of the difference, of the two numbers.

EXAMPLE.—4 is a common factor of 20 and 36. It is also a factor of 56 or 16.

**42. Extraction of Square Root by Means of Algebraic Formula.**

The formula used is

$$(a + b)^2 = a^2 + 2ab + b^2 = a^2 + (2a + b)b.$$

Conversely,

$$\begin{array}{r} a^2 + 2ab + b^2 \mid a + b \\ \underline{a^2} \\ 2a + b \mid \underline{2ab + b^2} \\ \underline{2ab + b^2} \end{array}$$

EXAMPLE.—Find the square root of 1156.

$$\begin{array}{r} 11'56 \mid a + b \\ \underline{30 + 4} \\ a^2 = 9\ 00 \\ \text{Trial divisor } 2a = 60 \quad \underline{2\ 56} \\ \underline{b = 4} \\ \text{Complete divisor} \\ (2a + b) = 64 \quad 2\ 56 \end{array}$$

**43. Short-cut Method for Square Root.**

If  $b$  is small, the term  $b^2$  can be omitted without a great error. Then we assume

$$(a \pm b)^2 = a^2 \pm 2ab \text{ approximately.}$$

An example will be used to show the process.

EXAMPLE.—Find the square root of 327.12.

Select a number whose square is nearest the given number. This can be done by inspection or by using a table of square or square roots when a logarithmic table is not available. Let us try  $a = 18$ ; then  $a^2 = 324$ , which is slightly smaller than the given number 327.12.

The difference between the numbers then equals  $+2ab$ , or

$$327.12 - 324 = 2 \times 18 \times b.$$

Therefore, 
$$b = \frac{3.12}{36} = .087.$$

But  $a + b$  is the square root of  $(a + b)^2$ ; then

$a + b = 18 + .087 = 18.087$ , which is the approximate square root of 327.12.

In case the square of the nearest number is greater than the given number, then

$$(a - b)^2 = a^2 - 2ab \text{ approximately.}$$

When  $b$  is found as before, it is subtracted from  $a$  to find the square root.

**44. Extraction of Cube Root by Means of Algebraic Formula.**

The formula used is

$$\begin{aligned}
 (a + b)^3 &= a^3 + 3a^2b + 3ab^2 + b^3 \\
 &= a^3 + (3a^2 + 3ab + b^2)b \\
 a^3 + 3a^2b + 3ab^2 + b^3 &\overline{) a + b} \\
 a^3 & \\
 \hline
 3a^2 + 3ab + b^2 &\overline{) 3a^2b + 3ab^2 + b^3} \\
 &\underline{3a^2b + 3ab^2 + b^3}
 \end{aligned}$$

EXAMPLE.—Find the cube root of 405,224.

$a^3$	=	405'224	$a + b$
		343 000	<u>70 + 4</u>
$3a^2$	=	14,700	62 224
$3ab$	=	840	
$b^2$	=	16	
$3a^2 + 3ab + b^2$	=	15,556	
$(3a^2 + 3ab + b^2)b$	=	62 224	

$(15,556 \times 4 = 62,224)$

**45. Short-cut Method for Cube Root.**—The method is similar to the square-root method with the same provision that  $b$  is small. We assume

$$(a + b)^3 = a^3 + 3a^2b \text{ approximately.}$$

EXAMPLE.—Find the approximate cube root of 2050.16. By trial, the nearest number cubed is  $(13)^3 = 2197$ , a number larger than the given number. Therefore, take  $a = 13$ .

The difference between the numbers, or

$$\begin{aligned}
 2197 - 2050.16 &= 146.84 = -3a^2b. \\
 -3a^2b &= -3 \times (13)^2 \times b = 146.84. \\
 -3 \times 169 \times b &= 146.84. \\
 b &= -.29.
 \end{aligned}$$

Then

$$\begin{aligned}
 (a - b), \text{ which is the cube root of } (a - b)^3, &\text{ becomes} \\
 13 - .29 &= 12.71.
 \end{aligned}$$

Therefore,

$$\sqrt[3]{2050.16} = 12.71.$$

A more accurate figure is 12.703.



## CHAPTER II

### APPROXIMATIONS. ABSOLUTE RELATIVE ERRORS

**46. Approximations.**—Engineers will sometimes thoughtlessly make a computation of quantities which have been found by measurements, instrument readings, and handbook data, and carry the operations to several unnecessary decimal places. These operations take considerable time, and the results give a false impression of accuracy. Every measurement taken is an approximation, and the degree of accuracy should depend upon the purpose for which the measurement is to be used. For instance, an engineer wishes to compare the size of a drum shaft on a French hoist with one of his own make. The French blueprints show the diameter to be 24 centimeters. The engineer will probably glance at a conversion table and see that 1 centimeter = .3937 inch, and mentally multiply 24 by .4. In case he expects to shrink-fit a gear on that shaft, he will undoubtedly use the full constant .3937 to compute the bore of the gear.

**47. Rounded Numbers.**—A number is *rounded off* by dropping one or more digits at the right, and if the last digit dropped is 5, 6, 7, 8, or 9, increase the preceding digit by 1. Thus, the successive approximations to  $\pi$  obtained by rounding off 3.14159 . . . are 3.1416, 3.142, 3.14, 3.1, 3.

**48. Significant Figures.**—The degree of precision of a measurement is determined by the number of significant figures contained in the number expressing the measurement. The significant figures of a number are the digits 1, 2, 3, 4, 5, 6, 7, 8, 9, together with such zeros as occur between them or have been retained in properly rounding them off. Thus, the number 3,496,000.0 has eight significant figures, since the 0 in the decimal place, according to the convention adopted, means that the number is exact to the nearest tenth. Thus, 0 is then essentially a digit and should be counted. Also, if a number such as 3999.7 is rounded by dropping the 7, the number becomes 4000, which should be considered as having four significant figures.

If a measurement of a length is expressed as 14.1 inches, this means that the measurement is exact to the *nearest tenth* of an inch. If the measurement of this length were exact to the nearest hundredth of an inch, it would be expressed by the number 14.10. In other words,  $x = 14.1$  means that the exact value of  $x$  lies between 14.05 and 14.15, and  $x = 14.10$  means that the exact value of  $x$  lies between 14.095 and 14.105.

**49. Retained Digits.**—The digits which are not replaced by ciphers, when a number is rounded or approximated, will be called the retained digits. If 248,000 is taken instead of 247,895, then three digits are retained.

**50. The numerical value of a number** is the positive value of the number irrespective of sign. It will be indicated by vertical lines on each side of the number, as  $|a|$ . If  $a$  is positive,  $|a|$  means the same as  $a$ ; but if  $a$  is negative,  $|a|$  means the corresponding *positive* number  $-a$ .

In what follows, we shall speak of 1, 10, 100, etc., respectively, as a unit of the first, second, or third order; and similarly .1, .01, .001, etc. will be called units of the first, second, or third decimal order.

**51. The absolute error**, as taken here, is the approximate value minus the exact value of a number. If 2.46 is as an approximation used in a computation where 2.457 is the exact value, then  $2.46 - 2.457 = .003$ , the absolute error. The absolute error is positive if the approximate number is greater than the exact value, and negative if the approximate number is less than the exact value. If 37.142 is taken instead of 37.14247, then  $37.142 - 37.14247 = -.00047$ , a negative absolute error.

**52. The relative error** is the *ratio of the absolute error to the exact value*. Since the relative error is a ratio, it is an abstract number and is often expressed in percentage.

**53. The Limiting Error.**—When the greatest permissible numerical value of the absolute or relative error of the result of a computation is arbitrarily fixed or predetermined at the beginning of a solution, it will be called the *limiting error* of the result.

If .01 is the *limiting absolute error* of a number whose exact value is 81.666, then either 81.67 or 81.66 is within the limit of

.01. The absolute errors are .004 and  $-.006$ , respectively. The limiting absolute error .01 means that the numerical value of the absolute error in the result must not be greater than .01. Any number between 81.657 and 81.675 is within the limit of an absolute error of .01 for the exact value 81.666.

In the same manner, a limiting relative error of 1 per cent means that the numerical value of the relative error in a result is to be less than 1 per cent.

**54. Errors in Numbers.**—If 212,700 is used instead of 212,667, the absolute error is 33 and the relative error is  $\frac{33}{212,667}$ .

If 212.7 is used instead of 212.667, the absolute error is .033, and the relative error is  $\frac{.033}{212.667}$ .

If .2127 is used instead of .212667, the absolute error is .000033, and the relative error is  $\frac{.000033}{.212667}$ .

$$\frac{33}{212,667} = \frac{.033}{212.667} = \frac{.000033}{.212667}$$

The relative error is not affected by the location of the decimal point but by the number of digits rounded off. In all three cases, the relative error is .00015 approximately.

Now, if 212,600 is used instead of 212,667, the relative error is  $\frac{-67}{212,667}$ , and

$$\left| \frac{-67}{212,667} \right| < \frac{100}{212,667} = \frac{1}{2126.67} < \frac{1}{1000} = .001.$$

Hence, the relative error is within the limit of .001, or the unit of the third decimal order, which is one order less than the number (4) of digits retained (Art. 49).

Again, if 213,000 is used in the computation instead of the above number 212,667, the absolute error is 333 and the relative error is  $\frac{333}{212,667}$ .

Then

$$\frac{333}{212,667} = \frac{.333}{212.667} < \frac{1}{212.667} < \frac{1}{100} = .01.$$

The relative error is within the limit of .01, or the unit of the second decimal order (Art. 50), which is one order less than the number (3) of digits retained (Art. 49).

If 212,600 is used instead of 212,637, then the absolute error is -37 and the relative error is  $-\frac{37}{212,667}$ .

$$-\frac{37}{212,637} = -\frac{.37}{2126.37}$$

$$\left| \frac{-.37}{2126.37} \right| < \frac{1}{2126.37} < \frac{1}{1000} = .001.$$

The numerical value of the relative error is within the limit of .001

**55.** To approximate a number when the specified limiting relative error is a unit of a given decimal order, retain one more digit in the number than the order of the unit. *Conversely*, if a given number be approximated by rounding it off, the numerical value of the relative error will be less than the unit of decimal order one less than the number of digits retained.

Then, to approximate a given number so that the relative error will be within the limiting error of 1 per cent, or .01, retain three digits; and to be within the limiting error of .001, retain four digits. Thus, to approximate 314,159, 31,415.9, 3.14159, .0314159, with a limiting error of .001, take 314,200, 31,420, 3.142, and .03142, respectively. *Conversely*, if we use 3.21 instead of 3.2142, the relative error is within the limiting relative error .01, or 1 per cent.

In considering errors in sums, differences, products, and quotients in the following paragraphs, the given numbers to be added, subtracted, multiplied, or divided are understood to be positive.

**56. Absolute Error in Additions.**—The absolute error of the sum of several rounded numbers equals the algebraic sum of the absolute errors of the numbers. This discussion will be confined to the rounding of decimals, because whole numbers are seldom rounded in addition.

If not more than twenty numbers are added, and the limiting absolute error is the unit of a certain given decimal order, the number of decimal places retained in each number should be

one more than the given decimal order of the unit. For an answer correct to the nearest hundredth, when adding not more than twenty numbers, retain three decimal places. The absolute error of each of the numbers will be less than .0005, and for twenty numbers ( $20 \times .0005 = .01$ ), the absolute error cannot exceed a hundredth in the rounded sum. For less than ten rounded numbers to be added, the maximum error of the sum cannot exceed .005 and, when rounded, will not add another unit to the rounded sum, since it will be dropped in rounding.

By approximating the numbers nearly to equalize the positive and negative absolute errors, the absolute error of the sum will be reduced in size.

EXAMPLE.—Add 4.3416, 9.81643, .7295, 21.6844, .0037, 762.123, and 1.2845. The sum is to be approximately correct to two decimal places.

$$\begin{array}{r}
 4.342 \\
 9.816 \\
 .730 \\
 21.684 \\
 .004 \\
 762.123 \\
 1.284 \\
 \hline
 799.983
 \end{array}$$

If there are more than 20 but less than 200 numbers to be added, take two more decimal places than the decimal order of the limiting unit.

**57. The Relative Error in Addition.**—The relative error of the sum of several numbers is equal to the absolute error of the sum divided by the sum, or

$$\text{Relative error of the sum} = \frac{\text{Absolute error of the sum}}{\text{Sum}}$$

Then

Absolute error of the sum = Relative error of the sum  $\times$  sum, and

Limiting absolute error of each number must not be greater than

$$\frac{\text{Limiting relative error of the sum} \times \text{sum}}{\text{Number of numbers}}$$

Unfortunately, the sum is not yet known, but by roughly approximating it mentally, an approximation of the limiting

absolute error which each number should not exceed is found. It is usually sufficiently accurate to round off all but the first significant figures of the numbers for the trial sum, but small numbers in combination with large numbers may be neglected. A little practice will determine the best results.

**EXAMPLE.**—Approximate the sum of the following numbers to within 1 per cent of the correct value:

2868.146  
3380.433  
845.314  
27.841  
343.50

A glance will show that the sum is not far from 7000.

Then

$$\frac{7000}{5} = 1400 \text{ (mentally).}$$

**SOLUTION.**

2870.  
3380.  
850.  
30.  
340.  
7470.

Multiplying by .01 gives 14, the limiting absolute error for each number. If the units' column is rounded into the tens' column, the sum will be correct to within 1 per cent, because in none of the numbers will the numerical value of the absolute error exceed 14. The solution is as shown, but in actual practice the numbers should not be rewritten and the rounding off should be done mentally as the tens' column is added.

**58. Absolute Errors in Multiplication.**—When a correct factor is multiplied by an approximate factor, and a *limiting absolute error* of accuracy is desired in the product, let

$a$  = the correct first factor.

$b$  = the approximate second factor.

$\Delta$  = the absolute error of the second factor (positive or negative).

$A$  = the absolute error of the product.

Then  $b - \Delta$  = the exact factor.

$ab$  = the approximate product.

$a(b - \Delta)$  = the exact product.

The difference between the approximate and the exact product is the absolute error of the product.

Then

$$A = ab - a(b - \Delta) = ab - ab + a\Delta = a\Delta.$$

If a limiting absolute error of .01 is desired in the product, then  $|a\Delta|$  must be within the limit of .01, or  $|\Delta|$  must be taken within the limit of  $\frac{.01}{a}$  in the second factor. The error of the product will be positive or negative according to whether  $\Delta$  is positive or negative. If  $\Delta$  is taken positive, the approximate product will be greater than the exact product and less than the exact product if  $\Delta$  is taken negative.

If a limiting error of .001 is permissible in the product, then the limiting absolute error in the approximate or rounded number must be within the limit of  $\frac{.001}{a}$ .

EXAMPLE.—The exact number 391.8 is to be multiplied by 3.1415926 rounded off to give a product with absolute error within the limit .01.

If  $\Delta$  is taken within the limit of  $\frac{.01}{391.8}$ , or (by shifting the decimal points) within the limit  $\frac{.00001}{.3918}$ , then by taking a limit of  $\frac{.00001}{1}$ , or .00001, which is still more within the limit, the product will then be within the limit of .01.

If five decimal places are retained, or 3.14159 taken, the absolute error is  $-.0000026$ , which is within the limit of .00001.

RULE.—*Retain as many decimal places in the approximate factor as there are whole numbers in the other factor, plus the number of decimal places in the limiting error of the product.*<sup>1</sup>

Since  $A = a\Delta$ , or  $\Delta = \frac{A}{a}$ , then  $\Delta$  will either have as many decimal places as indicated by the rule, or one less than that given by the rule. Therefore, if the rule is followed, the absolute error of the product will be less than the limiting error.

As 391.8 has three whole numbers and .01 has two decimal places, the approximate factor should be taken with five decimal places. Therefore, take

$$391.8 \times 3.14159.$$

<sup>1</sup> The numerical value of the absolute error of the product under this rule will not only be less than the specified limiting error but it will be less than five units in the next decimal place.

If the limiting error of the product is to be within .001, then six decimal places should be taken, or 3.141593.

**59. If both factors are approximate and the product is to be correct to within a certain limiting absolute error, let**

$a$  = the correct first factor.

$c$  = the correct second factor.

$\Delta_1$  = the absolute error of the first factor (positive or negative).

$\Delta_2$  = the absolute error of the second factor (positive or negative).

$A$  = the absolute error of the product.

Then

$a + \Delta_1$  = the approximate first factor.

$c + \Delta_2$  = the approximate second factor.

$ac$  = the correct product.

$(a + \Delta_1)(c + \Delta_2) = ac + c\Delta_1 + a\Delta_2 + \Delta_1\Delta_2$  the approximate product.

The approximate product less the correct product equals the absolute error of the product, or

$$A = ac + c\Delta_1 + a\Delta_2 + \Delta_1\Delta_2 - ac = c\Delta_1 + a\Delta_2 + \Delta_1\Delta_2.$$

Now in practice,  $\Delta_1$  and  $\Delta_2$  are small, and  $\Delta_1\Delta_2$  is very small compared to  $c\Delta_1 + a\Delta_2$  and may be neglected. Therefore, approximately,

$$A = c\Delta_1 + a\Delta_2,$$

and hence

$$|A| \bar{\approx} |c\Delta_1| + |a\Delta_2|.$$

If each factor is approximated according to the rule given in the preceding article, the absolute error of the product will be less than the limiting error. The absolute error in the preceding article was  $a\Delta$ , and the absolute error in the present case is made up of two parts  $c\Delta_1$  and  $a\Delta_2$ , each less than half the limiting error.

**RULE.**—Take as many decimals in the multiplicand as there are whole numbers in the multiplier, plus the number of decimals in the limiting error. Also, take as many decimals in the multiplier as there are whole numbers in the multiplicand, plus the number of decimals in the limiting error.



EXAMPLE.—Round off the numbers 30.87541 and 6.21832 so that the absolute error of the product will be less than .01. According to the rule, take three decimal places in the first factor and four in the second factor.

$$30.875 \times 6.2183 = 191.99.$$

If we go a step further and approximate the numbers so that the errors have opposite signs, the absolute error of the product will often be less than when the signs are taken alike.

**60. The Relative Error in Multiplication.**—If a product of an exact number and an approximated number is limited to a certain relative error or is to be correct to within a certain per cent, then let

- $a$  = the correct factor.
- $c$  = the correct second factor.
- $\Delta$  = the absolute error of the second factor.
- $r$  = the relative error of the second factor.
- $R$  = the relative error of the product.

Then

$$c + \Delta = \text{the approximate second factor.}$$

$$r = \frac{\Delta}{c} = \text{the relative error of the second factor.}$$

$$ac = \text{the correct product.}$$

$$a(c + \Delta) = \text{the approximate product.}$$

$$a(c + \Delta) - ac = a\Delta = \text{the absolute error of the product.}$$

$$\frac{a\Delta}{ac} = \frac{\Delta}{c} = r = \text{the relative error of of the product (positive or negative).}$$

The relative error of the product will be the same as the relative error taken in the approximated factor.

If we wish a product correct to within a certain per cent, one factor can be approximated to that same per cent, and be within the limit of the limiting relative error.

EXAMPLE.—Multiply the exact number 527.8 by 3.1415926  $\pi$  the product correct to within 1 per cent.

For a number to have a relative error of not more than 1 per cent, or 01, retain three digits (Art. 55). Therefore, take

$$527.8 \times 3.14.$$

If the relative error is taken positive in the approximate number, the relative error of the product will also be positive, and the product will be greater than the exact product.

An examination of the relative error of a factor may show that the product is sufficiently accurate for a small number of retained digits (Art. 49).

For the example just given, if 3.1 is taken instead of 3.1415926, the relative error is  $-.013$  approximately (Art. 54), which is a little greater numerically than  $-1$  per cent.

In many cases, especially when a slide rule is used, the number must be approximated because it is beyond the range of the rule. In this case, the relative error can be used as a correction factor and the corrected result will be nearer the exact result.

**EXAMPLE.**—Multiply the correct factor 3.55 by 21.245:

Three digits of 21.245 will be retained, as that is about the limit of the slide-rule setting. The relative error is approximately  $-.002$  if 21.2 is taken (Art. 54).

The minus sign indicates that the approximate product is less than the exact product and equals approximately  $\frac{998}{1000}$  of the exact product. An additional operation of dividing the approximate product by .998, a corrective factor, will make the approximate product more nearly correct. When not using the slide rule, simply take .002 of the approximate product and add the result to the approximate product. This should be done mentally.

**61.** If both factors are approximated, and their product is to be correct to within a *certain per cent*, or a *certain relative error*, then let

$a$  = the correct first factor.

$c$  = the correct second factor.

$\Delta_1$  = the absolute error of the first factor.

$\Delta_2$  = the absolute error of the second factor.

$r_1$  = the relative error of the first factor (positive or negative).

$r_2$  = the relative error of the second factor (positive or negative).

$R$  = the relative error of the product.

Then  $a + \Delta_1 =$  the approximate first factor.

$c + \Delta_2 =$  the approximate second factor.

$r_1 = \frac{\Delta_1}{a} =$  the relative error of the first factor.

$r_2 = \frac{\Delta_2}{c} =$  the relative error of the second factor.

$ac =$  the correct product.

$$(a + \Delta_1)(c + \Delta_2) = ac + c\Delta_1 + a\Delta_2 + \Delta_1\Delta_2.$$

$$= ac + c\Delta_1 + a\Delta_2 \text{ with } \Delta_1\Delta_2 \text{ discarded} \\ (\text{Art. 59}).$$

$=$  the approximate product.

$$R = \frac{(ac + c\Delta_1 + a\Delta_2) - ac}{ac} = \text{the relative error of the product.}$$

$$= \frac{c\Delta_1 + a\Delta_2}{ac} = \frac{c\Delta_1}{ac} + \frac{a\Delta_2}{ac}.$$

$$= \frac{\Delta_1}{a} + \frac{\Delta_2}{c}.$$

Or

$$= r_1 + r_2.$$

$$|R| = |r_1 + r_2|.$$

Or

$$|R| \leq |r_1| + |r_2|.$$

By taking  $r_1$  and  $r_2$  with opposite signs, the value  $R$  is less than when  $r_1$  and  $r_1$  are taken with both signs alike.

If a limiting relative error of 1 per cent is permissible in an approximate product, then each factor rounded to three retained digits, the relative error of the product will not exceed .01, even if the relative errors of the factors have the same sign.

*Retain one more digit in each factor than there are decimal places in the limiting error.*

EXAMPLE.—Find the product of 314.15928 and 27.18281828 to within a limit of 1 per cent.

Retain three digits in each factor.

$$314. \times 27.2 = 8540.8.$$

A more exact product for comparison is 8539.735.

*For the limiting error of .001 or one-tenth of 1 per cent, retain four digits in each factor if the relative errors of the factors are not mentally computed.*

If  $r_1$  is nearly equal to  $r_2$  and opposite in sign, then two significant figures may often be taken in each factor for the limiting error of 1%.

EXAMPLE.—Approximate the numbers 31,885 and 113.84 and have their product correct to within 1 per cent.

If 32,000 is taken for 31,885, the relative error is  $\frac{115}{31,885}$ , or .0036.

If 110 is taken for 113.84, the relative error is  $\frac{3.84}{113.84} = -.0033$ .

$$|R| = .0036 - .0033 = .0003.$$

**62. When several factors are multiplied together, the relative error of the product is approximately equal to the algebraic sum of the relative errors of the factors.**

If one more digit is retained (Art. 49) than there are decimal places in the limiting error (Art. 53) and the factors rounded (Art. 47), the algebraic sum of the relative error may be greater than the limiting error unless some of the factors are approximated with the relative errors of the opposite sign to that for rounding. Naturally to select a factor to make a large difference in the algebraic sum of the relative errors, we would choose one of the given factors whose left-side digits are numerically small, as 112,875.

If 112,875 is approximated negatively to 112,000, or 111,125 is approximated positively to 112,000, the error is greater than if factors like 893,875 or 892,125 (left-side digits numerically large) are approximated to 893,000.

EXAMPLE.—If three digits for each factor are retained in  $928.41 \times 27.621 \times 33.462 \times 813.16$ , what is the approximate error?

The approximate relative error of each factor will be written above each factor.

$$\begin{array}{ccccccc} -.0005 & -.0009 & +.001 & -.0002 & & & \\ 928. & \times 27.6 & \times 33.5 & \times 813 & = & 697,577,414.4 & +. \end{array}$$

The approximate error of the product equals

$$-.0005 - .0009 + .001 - .0002 = -.0006.$$

The third factor 33.462 was approximated with a positive error instead of rounded to a negative error which equalized the algebraic sum to a greater extent.

A correcting operation can be made, especially if a slide rule is used for the computation, by dividing the approximate product

by .9994 or by mentally multiplying the approximate product by .0006 and adding the result to the approximate product.

If two digits are retained in each factor, then we have

$$\begin{array}{cccccc} +.002 & -.025 & +.02 & -.004 & & -.007 \\ 930 \times 27 \times 34 \times 810 = & 691,529,400. \end{array}$$

The relative errors should be computed mentally as the factors are approximated, and the work proceeds. If the algebraic sum of the relative errors is excessive, the correction factor can be used.

63. The effect of dropping the right-hand numbers in both the multiplicand and multiplier is clearly shown in the following example:

$$\begin{array}{r} 245678\cancel{8} \\ 3134\cancel{6}\cancel{5}\cancel{2} \\ \hline A \left\{ \begin{array}{l} 4913 / 572 \\ 12283 / 930 \\ 14740 / 716 \\ \hline 9827 / 144 \\ 7370 / 358 \\ 2456 / 786 \\ 7370 / 358 \\ \hline 7701 \quad 169148472 \end{array} \right. B \end{array}$$

If the 2, 5, and 6 of the multiplier are dropped in succession, the first, second, and third rows indicated at *A* will disappear, and if the 6, 8, and 7 of the multiplicand are dropped, the diagonal rows indicated at *B* will disappear. It is quite evident that the parallelogram areas of figures *A* and *B* beyond the order of significant figures we have retained in the multiplier and multiplicand modify the product. If we retain or equalize the numbers to four places, for example, in the multiplicand and multiplier, we cannot expect our answer to be correct to more than four places.

64. A modification of the last method, involving a short cut. After having determined the number of significant figures, annex a zero to the multiplicand. Multiply by the first figure on the left of the multiplier. Drop the last figure of the multiplicand and multiply by the

$$\begin{array}{r} 27.170 \times 3.142 \\ \hline 81510 \\ 2717 \\ 108547 \\ \hline 85,365 = 85.37 \end{array}$$

second figure of the multiplier. Drop the next figure of the multiplicand and multiply by the third figure of the multiplier but carry the amount from the figure dropped. Thus, in the example, having dropped the 7 and multiplied by 4, we say  $4 \times 7 = 28$ , carry 3.,  $4 \times 1 = 4 + 3 = 7$  and so on.

In the usual manner, if we multiply  $14.3256 \times 2.68446$  and desire an answer correct to three decimal places, we will observe that we have a total of five significant figures in the answer. We, therefore (Art. 59), should retain four decimals in the multiplicand and five decimals in the multiplier, thus,

$$14.3256 \times 2.68446 = 38.456.$$

If the short-cut method is used instead of the regular method, add another significant figure to the multiplicand.

If we wish to multiply two numbers like  $14.32 \times 2.68443$ , the first one approximate due to measurement, it is sufficient to use four decimal figures in the second number, as

$$14.32 \times 2.6844.$$

**65. The Absolute Error in Division.**—If the divisor is exact and the dividend is approximate, to find a quotient which is accurate to within a certain absolute error, then let

$a$  = the correct dividend.

$c$  = the correct divisor.

$\Delta$  = the absolute error of the dividend.

$A$  = the absolute error of the quotient.

Then

$\frac{a}{c}$  = the correct quotient.

$\frac{a + \Delta}{c}$  = the approximate quotient.

$A = \frac{a + \Delta}{c} - \frac{a}{c} = \frac{\Delta}{c}$ , the absolute error of the quotient.

Therefore,

$$\Delta = Ac.$$

*The absolute error of the dividend must not be greater than the product of the divisor by the limiting absolute error of the quotient.*

**EXAMPLE.**—Calculate correctly to within a unit of the third decimal place (.001) when the divisor is correct:

$$216.58373 \div 435.$$

$\Delta$  should not be greater than  $.001 \times 435 = .435$ . Therefore, we will use 217 which has a positive error of .42 which is within the limit of .435.

$$217 \div 435 = .499.$$

A more exact quotient is .49789, which gives an absolute error of .0011, which is slightly in excess of the limiting error .001, because the quotient .4989 was rounded to .499.

A positive error taken in the dividend gives a positive error in the quotient.

**66. Relative Error in Division.**—If the divisor is exact and the dividend is approximate, to find a quotient which is accurate to within a certain relative error, let

$a$  = the correct dividend.

$c$  = the correct divisor.

$\Delta$  = the absolute error of the dividend.

$r$  = the relative error of the dividend.

$Q$  = the relative error of the quotient.

Then

$a + \Delta$  = the approximate dividend.

$r = \frac{\Delta}{a}$ , the relative error of the dividend.

$\frac{a + \Delta}{c}$  = the approximate quotient

$\frac{a + \Delta}{c} - \frac{a}{c} = \frac{\Delta}{c}$  = the absolute error of the quotient.

$Q = \frac{\frac{\Delta}{c}}{\frac{a}{c}} = \frac{\Delta}{a} = r$ , the relative error of the quotient.

The relative error of the quotient, when the divisor is exact and the dividend is approximate, is the same as the relative error of the dividend.

If, then, a relative error of the dividend is taken not greater than the limiting relative error of the quotient, the relative error of the quotient will be within the limit desired. If a limit of 1 per cent is a condition in the quotient, use three significant figures in the dividend. If the limiting relative error is to be less than .001 in the quotient, use four significant figures (Art. 55).

EXAMPLE.—Divide 483.51 by the exact number 84 and leave the quotient correct to within a limit of 1 per cent.

Retain three digits (Art. 55) for the dividend, or 484.

$$484 \div 84 = 5.74.$$

**67. If both the dividend and divisor are approximated, and since the dividend is equal to the product of the divisor and the quotient, the relative error of the quotient is approximately the algebraic difference between the relative error of the dividend and the divisor.** If  $Q$ ,  $r_1$  and  $r_2$  are, respectively, the relative errors of the quotient, dividend, and divisor, then, approximately

$$Q = r_1 - r_2,$$

and hence,

$$|Q| < |r_1| + |r_2|.$$

The relative errors  $|r_1|$  and  $|r_2|$  of the dividend and divisor, respectively, should be taken both positive or both negative if possible, which reduces the relative error of the quotient, since  $Q$  is the algebraic difference of the relative errors of the dividend and divisor. The sign of the relative error of the quotient will be the same as that taken in the dividend. If possible, round both dividend and divisor by increasing both or by decreasing both.

The relative error of the quotient will not exceed the relative error of both the dividend and divisor, provided their signs are the same. *Consequently, if each is taken with a relative error less than the limiting error and with like signs, the relative error of the quotient will be less than the limiting error.*

If  $r_1$  and  $r_2$  are taken with opposite signs, then the relative error of the quotient becomes the numerical sum of the relative errors of the dividend and divisor.

The relative error of the dividend and divisor should be mentally examined to determine which sign makes the smaller numerical difference in their values, and the dividend and divisor approximated accordingly. One trial calculation of the difference of the relative errors should be sufficient to determine how many digits to retain.

EXAMPLE.—Divide 214.68 by 32.477 and be within a limiting error of one-tenth of 1 per cent.

For a trial retain three digits of both numbers and round with positive signs.



The error of the quotient equals  $(.0015) - (+.0007) = .0008$  approximately, which is within the limit  $.001$ .

**68. Short-cut Division.**—Consider the following example:

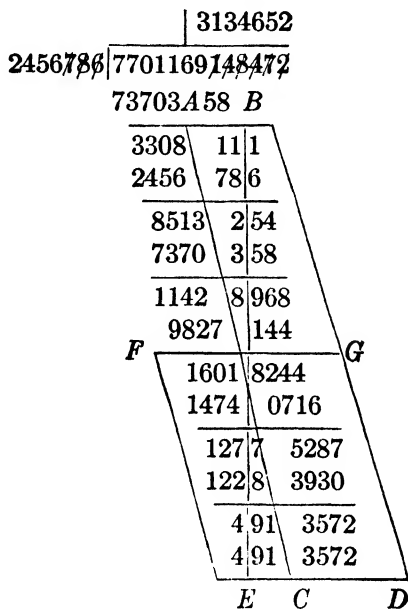

If some of the right-hand numbers of the divisor are rounded, as 786 (Art. 47), the figures in the parallelogram *ABCD* disappear.

If some of the right-hand numbers of the dividend are rounded off, as 148,472, the figures in the triangle *BED* are affected.

If some of the right-hand members of the quotient are not carried out, the numbers in the area *FGED* disappear.

If we drop a right-hand number of the divisor with each succeeding operation, none of the figures to the right of the vertical line *BE* will appear, and this is a change which affects the quotient the least.

The accuracy of the quotient depends on the number of figures retained in the divisor and the dividend.

We determine, first, the whole number of the quotient by inspection (Art. 30), and then decide how many decimal places

we should have, or the absolute error. We then have the number of significant figures in the quotient.

From Art. 33 we learned that in order to determine the correct figure in a quotient, at least two left-hand figures of the divisor must be used. Then, to have the last figure of the quotient correct, or nearly so, we should have two figures remaining for the last operation, after dropping a figure in each previous operation, or altogether one more figure will be retained in the divisor than figures in the quotient.

**69. Short-cut division** is similar to the regular method except that a right-hand figure is dropped from the divisor for each succeeding operation of multiplication. One more significant figure is taken than the regular method.

**EXAMPLE.**—Divide 77.01169148472 by 24.56786 and have an answer correct to three decimal places. By inspection (Art. 67), both dividend and divisor for regular division should have two decimal places or four significant figures, but for this method five will be taken. In case the first significant figure of the divisor is greater than the first significant figure of the dividend, add an extra figure to the dividend.

Before dropping a number in the divisor, ascertain what should be carried and add this to the product.

Retain 77.012 for the dividend and 24.567 for the divisor.

<u>24567</u>   77012	3134
<u>73703</u>	$3 \times 8 = 24$ carry 2
<u>3309</u>	$3 \times 7 = 21 + 2 = 23$
Drop 7 in divisor—	
<u>2457</u> —	$1 \times 7 = 7$ carry 1
<u>852</u>	$1 \times 6 = 6 + 1 = 7$
Drop 6 in divisor—	
<u>737</u> —	$3 \times 6 = 18$ carry 2
<u>115</u>	$3 \times 5 = 15 + 2 = 17$
Drop 5 in divisor—	
<u>98</u> —	$4 \times 5 = 20$ carry 2
24 remains of divisor	$4 \times 4 = 16 + 2 = 18$
<u>17</u>	

Another method is to retain one more figure in the divisor and the dividend and to disregard the carrying of the abandoned figures.

**70. Relative Error in Combined Multiplication and Division.**  
 The relative error of the result of expressions like

$$\frac{a \times b \times c}{d \times e \times f}, \quad \frac{a \times b \times c}{d \times e}, \quad \text{or} \quad \frac{a \times b}{d \times e \times f}$$

is approximately the difference between the algebraic sum of the relative errors of the factors in the numerator and the algebraic sum of the relative errors in the factors in the denominator. Digits may be retained in such a manner that the relative error of the result will be small.

EXAMPLE.—Compute

$$\frac{24.44 \times 3.1416 \times 8}{54.682 \times 10.94 \times 5.22}$$

Either select the trial relative errors of the factors of the numerator and likewise the denominator to reduce the algebraic sums as much as possible, or compare a relative error of a factor in the numerator with the relative error of a factor in the denominator having a like sign. This last method amounts to a cancellation of errors.

$$\begin{array}{r} - .02 \quad + .02 \\ \hline 24 \times 3.2 \times 8 \\ \hline 55 \times 10.9 \times 5.2 \\ \hline + .006 \quad - .004 \quad - .004 \end{array}$$

The difference between the algebraic sums is  
 $(- .02 + .02) - (+.006 - .004 - .004) = .002$  approximately.

The resulting relative error should show whether a sufficient number of digits has been retained, or whether a correction factor should be used, or whether more digits should be taken in the number. This question should be settled before the computation called for is started.

**71. The Relative Errors of Powers and Roots.**—The relative error of a power of an approximated number is approximately equal to the relative error of the number multiplied by the degree of the power. This is quite evident, for we have shown (Art. 61) that the relative error of a product is approximately equal to the algebraic sum of the relative errors of the factors. If then these several factors are all the same and there are  $u$  factors, the product of these factors would have a relative error of approximately  $u$  times the relative error of the factor.

Similarly, the relative error of a root is approximately equal to the relative error of the number divided by the degree of the root.

Fractional powers would also have relative error of approximately the relative error of the number multiplied by the fractional power.

**72. A New System of Multiplication.**—The author introduces the following system of multiplication for the first time:

It has the advantage that the numbers of highest order, or the left-hand figures, are put down first, followed by the ones of lesser and lesser importance which may be omitted when the proper limit of importance is reached. Take an example to illustrate. Suppose that we desire to multiply 345 by 234. First, place one number beneath the other as is done in the regular method. Then imagine a line rotating about a center, located midway between the vertical numbers to begin with, then move one-half a space for each succeeding operation, and find the products of the numbers that the line crosses in making the complete rotation each time.

The first center is halfway between 3 and 2. Draw the line vertically. The first product is 6. In completing the rotation, the line does not fall on any other two numbers. This is the total product for the first position of the center. Now move the center to the right midway between the first, or hundreds', column and the second, or tens', column.

$$\begin{array}{r} 345 \\ | \text{center} \\ \hline 234 \end{array}$$

Each time the center is moved, drop the product back one place. With the center in this second position, the rotation of the line gives the two products,

$$\begin{array}{r} 345 \\ \diagdown \text{center} \\ \hline 234 \\ 6 \\ 8 \\ 9 \end{array}$$

$$2 \times 4 \text{ and } 3 \times 3.$$

Moves the center another half space, which locates the center between the 4 above and the 3 below, and rotate. This gives the three products,

$$4 \times 3, \quad 5 \times 2, \quad \text{and} \quad 4 \times 3.$$

It is unnecessary to draw the line but advisable simply to make a dot for the center and rotate mentally, bearing in mind that a line striking a number two units to the left in the multiplicand will strike a number two units to the right in the multiplier. Begin over now and complete the process. The multiplication will appear as indicated at the right.



6			
8	}	Add	mentally
9			
12	}	Add	mentally
10			
12			
16	}	Add	mentally
15			
20			

80,730 Ans.

In the following example, do not overlook the fact that in the second position of the center, the line strikes not only the 3 and 7 but also the 3 and 4. The dot assists in following the operation.

4	3	2	1
.....			
7	3		

This method was devised in order to get the most important part first. The continuation of the process simply adds a correcting or error-reducing refinement to the result, which can be carried out to any desired degree.

2	8
3	3
2	3
1	3
3	
3	1
1	5
4	3
3	3

The method is also well adapted for multiplication with a standard adding machine. By taking each cross-product and dropping back a space on the machine each time a new center is taken, the machine will give the final product without any additional operations.

EXAMPLE.—Solve

$$246.4182 \times 211.6432$$

with an answer correct to within one-tenth of 1 per cent, or .001.

Each number should have four retained digits with one of them approximated positive.

2	4	6.4	1	8	2
2	1	1.7	4	3	2
<hr/>					
4					
10					
18					
32					
38					
46					
28					
<hr/>					
5,216,288					

## APPROXIMATION FORMS

## 73. Forms.

$$(1 + x)(1 + y) = 1 + x + y + xy.$$

$$(1 + x)(1 - y) = 1 + x - y - xy.$$

When  $x$  and  $y$  are very small fractions or decimals,  $xy$  is so small that it can be neglected. Therefore, the product can be approximated to

$$1 + x \pm y.$$

EXAMPLE.— $1.0015 \times 1.0024$ .

$$(1 + .0015)(1 + .0024) = 1 + .0015 + .0024 = 1.0039 \text{ approximately.}$$

EXAMPLE.— $1.032 \times .996$ .

$$(1 + .032)(1 - .004) = 1 + .032 - .004 = 1.028 \text{ approximately.}$$

## 74. Form.

$(1 + x)(1 + y)(1 + z) = 1 + x + y + z + xy + yz + xz + xyz$ .  
If  $x$ ,  $y$ , and  $z$  are sufficiently small, the last four terms can be neglected, and the approximation made equal to

$$1 + x + y + z.$$

EXAMPLE.— $1.011 \times 1.008 \times .998$ .

$$(1 + .011)(1 + .008)(1 - .002) = 1 + .011 + .008 - .002 \\ = 1.017 \text{ approximately.}$$

## 75. Forms.

$$\frac{1}{1 - x} = 1 + x \text{ approximately.}$$

$$\frac{1 + x}{1 + y} = 1 + x - y \text{ approximately.}$$

## 76. Form.

$$(1 \pm x)^n = (1 \pm x)(1 \pm x) \dots \text{ to } n \text{ factors.} \\ = 1 \pm x \pm x \pm \dots \text{ to } n \text{ number of } xs. \\ = 1 \pm nx.$$

Now  $n$  may be negative, fractional, integral, or irrational.  
Then

$$(1 + x)^2 = 1 + 2x \text{ approximately.} \quad \sqrt{1 - x} = 1 - \frac{1}{2}x \text{ approximately.}$$

$$(1 - x)^2 = 1 - 2x \text{ approximately.} \quad \sqrt{1 + x} = 1 + \frac{1}{2}x \text{ approximately.}$$

$$\frac{1}{\sqrt{1 + x}} = 1 - \frac{1}{2}x \text{ approximately.} \quad \frac{1}{\sqrt{1 - x}} = 1 + \frac{1}{2}x \text{ approximately.}$$

EXAMPLE.

$$\begin{aligned}(1.093)^4 &= (1 + .093)^4. \\ &= 1 + (.093 \times 4) = 1.373 \text{ approximately.}\end{aligned}$$

EXAMPLE.—Find the square root of 145.

$$\begin{aligned}145 &= [144(1 + \frac{1}{144})]^{\frac{1}{2}} = 12(1 + \frac{1}{144})^{\frac{1}{2}}. \\ &= 12(1 + \frac{1}{2} \times \frac{1}{144}) = 12(1 + \frac{1}{288}). \\ &= 12 + \frac{1}{24} = 12.0416.\end{aligned}$$

77. Form.

$(a \pm b)^n = a^n \pm na^{n-1}b$  approximately,  
provided  $b$  is small.

EXAMPLE.—Find the square root of 105.

$$\begin{aligned}\sqrt{105} &= \sqrt{100 + 5} = (100 + 5)^{\frac{1}{2}} = 100^{\frac{1}{2}} + \frac{1}{2} \times 100^{-\frac{1}{2}} \times 5. \\ &= 10 + \frac{1}{2} \times \frac{1}{10} \times 5. \\ &= 10 + \frac{1}{4} = 10.25 \text{ approximately.}\end{aligned}$$

EXAMPLE.—Find the square root of 620.

$$\begin{aligned}\sqrt{620} &= (625 - 5)^{\frac{1}{2}} = 625^{\frac{1}{2}} - \frac{1}{2} \times 625^{-\frac{1}{2}} \times 5. \\ &= 25 - \frac{1}{2} \times \frac{1}{25} \times 5 = 24.9 \text{ approximately.}\end{aligned}$$

EXAMPLE.—Find the cube root of 7.85.

$$\sqrt[3]{7.85} = (8 - .15)^{\frac{1}{3}} = 8^{\frac{1}{3}} - \frac{1}{3} \times \frac{1}{4} \times .15 = 2 - .0125 = 1.987 \text{ approximately.}$$

78. Form.

$$1 \pm \frac{a}{x} = a \mp ax, \text{ when } x \text{ is small.}$$

EXAMPLE.

$$\frac{8}{.9996} = 8 + 8(.0004) = 8.0032.$$

79. Reciprocal Approximations.—Reciprocals of  $1 \pm x$ , when  $x$  is small.

$$\begin{aligned}\frac{1}{1+x} &= 1 - x + (\text{error} < x^2 \text{ if } x \text{ is between } 0 \text{ and } 1). \\ &= 1 - x + x^2 - (\text{error} < x^3 \text{ if } x \text{ is between } 0 \text{ and } 1).\end{aligned}$$

$$\begin{aligned}\frac{1}{1-x} &= 1 + x + (\text{error} < x^2 + 2x^3 \text{ if } \frac{1}{2} > x > 0). \\ &= 1 + x + x^2 - (\text{error} < x^3 + 2x^4 \text{ if } \frac{1}{2} > x > 0).\end{aligned}$$

$$\frac{1}{a \pm b} = \frac{1}{a} \times \frac{1}{1 \pm \frac{b}{a}}, \text{ where } x = \frac{b}{a}.$$

## CHAPTER III

### ALGEBRAIC NOTATION. RATIO AND PROPORTION. BINOMIALS, TRINOMIALS, POLYNOMIALS. FACTORS AND MULTIPLES. RADICALS

#### ALGEBRAIC NOTATION

**80. Algebraic Signs.**—When only + and - , or only  $\times$  and  $\div$  , occur in a sequence, the operations are performed in order from left to right.

If  $\times$  or  $\div$  , or both, occur in connection with +, -, or both, the indicated multiplications and divisions are performed first, unless otherwise indicated.

A minus sign preceding a parenthesis operates to reverse the sign of every term within, when the parenthesis is removed.

#### RATIO AND PROPORTION

**81.** The quotient of two numbers obtained by dividing the first by the second is called the *ratio* of the two numbers.

The ratio of  $a$  and  $b$  is  $\frac{a}{b}$ , or  $a \div b$ .

Since ratio is in the form of a fraction, all principles applying to fractions can also be applied to ratios.

The statement that two ratios are equal is called a *proportion*.

$$\frac{2}{3} = \frac{4}{6}, \text{ or } a : b = c : d, \text{ or } a : b :: c : d.$$

The first and fourth terms of a proportion are the *extremes*, and the second and third terms are the *means*.

If the second and third terms are equal, either one of them is the *mean proportional* between the first and fourth terms.

$$a : b = b : c \text{ and } b = \sqrt{ac}.$$

If  $ad = bc$ , then

$$a : b = c : d.$$

$$b : a = d : c.$$

$$a : c = b : d.$$

$$c : a = d : b.$$



Since in each case the product of the extremes equals the product of the means, or  $ad = bc$ , either pair can be made the extremes and the other pair the means.

82. To prove that  $\frac{a+b}{a-b} = \frac{c+d}{c-d}$ , when  $\frac{a}{b} = \frac{c}{d}$ :

Since  $ad = bc$ , or  $bc = ad$ ,

multiplying by 2,

$$2bc = 2ad, \text{ which can be put in the form,}$$

$$bc + bc = ad + ad.$$

Transposing terms,

$$bc - ad = ad - bc.$$

Adding  $ac - bd$  to both sides,

$$ac + bc - ad - bd = ac - bc + ad - bd.$$

Combining,

$$c(a+b) - d(a+b) = c(a-b) + d(a-b), \text{ or } (a+b)(c-d) = (a-b)(c+d)$$

Dividing both sides by  $(a-b)(c-d)$ , then

$$\frac{(a+b)(c-d)}{(a-b)(c-d)} = \frac{(a-b)(c+d)}{(a-b)(c-d)}, \text{ or } \frac{(a+b)}{(a-b)} = \frac{(c+d)}{(c-d)}.$$

In like manner the following proportions can be proved, when  $ad = bc$ :

$$a + b : b = c + d : d. \quad a - b : a = c - d : c.$$

$$a + b : a = c + d : c. \quad a + c : a - c = b + d : b - d.$$

$$a - b : b = c - d : d. \quad a + b : a - b = c + d : c - d.$$

The products of the corresponding terms of two or more proportions are in proportion.

If  $\frac{a}{b} = \frac{c}{d}$  and  $\frac{m}{n} = \frac{p}{q}$ , then  $\frac{am}{bn} = \frac{cp}{dq}$ .

Multiplying or dividing both terms of a ratio does not change the value of the ratio.

$$\frac{a}{b} = \frac{am}{bm}.$$

If  $a : b = c : d$ , then  $ma : mb = nc : nd$ , or  $\frac{a}{m} : \frac{b}{m} = \frac{c}{n} : \frac{d}{n}$ ,

or  $ma : nb = mc : nd$ , or  $\frac{a}{m} : \frac{b}{m} = \frac{c}{m} : \frac{d}{m}$ .

If four numbers are in proportion, their like powers and also their like roots will be in proportion.

In  $a : b = c : d$ , then  $a^n : b^n = c^n : d^n$ , and  $a^{\frac{1}{n}} : b^{\frac{1}{n}} = c^{\frac{1}{n}} : d^{\frac{1}{n}}$ .

If any continued proportion, as  $a : b = c : d = e : f = g : h$ , the sum of the first terms, *antecedents*, is to the sum of the second terms, *consequents*, as any antecedent is to its consequent, or

$$\frac{a + c + e + g}{b + d + f + h} = \frac{a}{b} = \frac{c}{d} \text{ etc.};$$

or if

$$\frac{a}{x} = \frac{b}{y} = \frac{c}{z} = r \text{ (a fixed ratio),}$$

then

$$\left( \frac{a + b + c + \dots}{x + y + z + \dots} \right) = r.$$

If a problem requires the finding of two numbers which are to each other as  $m : n$ , it is advisable to represent these unknown numbers by  $mx$  and  $nx$ .

If  $a : b = b : c = c : d$ , then  $b = \sqrt[3]{a^2d}$  and  $c = \sqrt[3]{ad^2}$ , which are two geometric means between  $a$  and  $d$ .

**83. The proportional divider** is an instrument used principally for transferring dimensions from a given figure to make either an enlarged or a reduced similar figure. It is also very convenient as an aid in solving graphical problems (Arts. 200, 202, 203, 208).

The pivot of the divider can be shifted along the greater portion of its length, thus giving different ratios of the distances between the points at one end to the distance between the points at the other end. For a fixed setting of the pivot, the distances between the points maintain a fixed ratio within the range of the instrument.

For linear dimensions, the ratios are marked on the face called *lines*. If the pivot is moved to match 2 on the scale, the distance between the points at one end will be twice as great as the distance between the points at the other end.

The master proportional divider, from which the commercial dividers are made, is divided into 2000 equal divisions from end to end, although only about 1000 divisions appear on the instrument. For a 10-inch divider, then, the divisions are 200 per inch which may be read by a vernier. It is to be regretted that this scale is not on the commercial divider.

The settings for the master divider on the fundamental scale of 2000 units are found as follows (see Fig. 1):

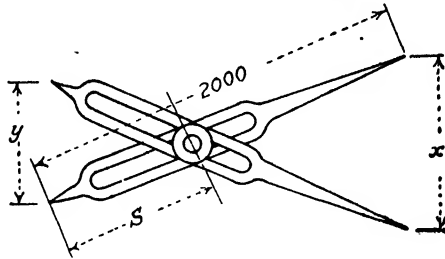

FIG. 1.

Let  $y$  = the lesser term of the ratio.  
 $x$  = the greater term of the ratio.  
 $S$  = the setting on the scale of 2000 units.

Then

$$\frac{y}{x} = \frac{S}{2000 - S},$$

or

$$2000y - yS = xS.$$

$$2000y = xS + yS = (x + y)S.$$

$$S = \frac{2000y}{x + y}.$$

For a 1 to 2 ratio,  $y = 1$ ,  $x = 2$ , and  $S = \frac{2000 \times 1}{2 + 1} = 667$  units.

A convenient way of setting the proportional divider to some ratio not given on the instrument is to take one of the scales on an engineer's triangular scale and set off distances equal to the ratio. The engineer's scale is marked 10, 20, 30, 40, 50, and 60 divisions per inch, and one of the six scales will be found suitable for the purpose. For instance, to find a ratio of 23 to 31, take the scale of 60 per inch and measure on a line the two distances, 23 and 31.

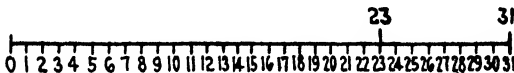

FIG. 2.

Move the location of the pivot until the short legs measure 23 when the long legs measure 31 units.

Two or three trials will accomplish the setting.

For a setting of 8 to 15, use the divisions on the 30-per-inch scale.

If the ratio is given as a decimal like .72 to 1, simply multiply by 10 and take the divisions marked 7.2 and 10 for the measurements on the 20-per-inch scale.

#### 84. Binomial Theorem for Positive Integral Exponents.—

This theorem is used to express  $(a + b)^n$  in expanded form.

By actual multiplication, for instance,

$$(a + b)^2 = a^2 + 2ab + b^2.$$

$$(a + b)^3 = a^3 + 3a^2b + 3ab^2 + b^3.$$

$$(a + b)^4 = a^4 + 4a^3b + 6a^2b^2 + 4ab^3 + b^4.$$

$$(a + b)^5 = a^5 + 5a^4b + 10a^3b^2 + 10a^2b^3 + 5ab^4 + b^5.$$

If  $n$  represents the exponent of the binomial in any of the above cases, the form becomes

$$[1] \quad (a + b)^n = a^n + na^{n-1}b + \frac{n(n-1)}{1 \times 2} a^{n-2}b^2 + \\ \frac{n(n-1)(n-2)}{1 \times 2 \times 3} a^{n-3}b^3 + \dots \\ \dots + \frac{n(n-1)(n-2) \dots (n-r+2)}{\underline{r-1}} a^{n-r+1}b^{r-1} \dots b^n.$$

The expansions follow certain definite laws which will now be given:

*First.* The exponent of  $a$  in the first term of the expansion is the same as the exponent of the binomial and decreases by 1 in each succeeding term, being 0 in the last term.

*Second.* The exponent of  $b$  increases by 1 from term to term, being 0 in the first term and the same as the exponent of the binomial in the last term.

*Third.* To find the coefficient of any term, multiply the coefficient preceding it by the exponent of  $a$ , and divide the product by the number of the preceding term.

*Fourth.* The sign of each term of the expansion is plus, if  $a$  and  $b$  are positive; and the signs of the even-numbered terms are minus, if  $b$  only is negative.

The proof that the expansion is true for all positive integral values of the exponent can be shown by mathematical induction.

For  $n$  fractional or negative, see (Art. 458).

**85.** A very good way is to expand the letters first, then place below the coefficient of each term, and then the signs, and combine.

**EXAMPLE.**—Find the fifth power of  $(b - y)$  by binomial theorem.

$(b - y)^5 =$							
letters	exponents	$b^5$	$b^4y$	$b^3y^2$	$b^2y^3$	$by^4$	$y^5$
coefficients		1	5	10	10	5	1
signs		+	-	+	-	+	-
combining		$b^5 - 5b^4y + 10b^3y^2 - 10b^2y^3 + 5by^4 - y^5.$					

**NOTE:** The coefficient of the fourth term is found by multiplying the coefficient of the third term by the exponent of  $b$ , or  $10 \times 3 = 30$ , and dividing by 3 or the number of that term.

**86.** To find the  $r$ th term of binomial expansion  $(a + x)^n$ : Substitute the values of  $n$  and  $r$  in the expression,

$$\frac{n(n-1)(n-2) \dots (n-r+2)}{\underline{r-1}} a^{n-r+1} x^{r-1}.$$

**EXAMPLE.**—Find the sixteenth term of  $(a + x)^{20}$ .

$$r = 16, \text{ and } n = 20.$$

$$(n - r + 2) = (20 - 16 + 2) = 6.$$

$$\therefore \frac{20 \cdot 19 \cdot 18 \cdot 17 \cdot 16 \cdot 15 \cdot 14 \cdot 13 \cdot 12 \cdot 11 \cdot 10 \cdot 9 \cdot 8 \cdot 7 \cdot 6}{1 \cdot 2 \cdot 3 \cdot 4 \cdot 5 \cdot 6 \cdot 7 \cdot 8 \cdot 9 \cdot 10 \cdot 11 \cdot 12 \cdot 13 \cdot 14 \cdot 15} a^{5} x^{15}.$$

Cancelling numbers that appear in both numerator and denominator,

$$\frac{20 \cdot 19 \cdot 18 \cdot 17 \cdot 16 \cdot 15 \cdot 14 \cdot 13 \cdot 12 \cdot 11 \cdot 10 \cdot 9 \cdot 8 \cdot 7 \cdot 6}{1 \cdot 2 \cdot 3 \cdot 4 \cdot 5 \cdot 6 \cdot 7 \cdot 8 \cdot 9 \cdot 10 \cdot 11 \cdot 12 \cdot 13 \cdot 14 \cdot 15},$$

the expression becomes

$$\frac{20 \cdot 19 \cdot 18 \cdot 17 \cdot 16}{1 \cdot 2 \cdot 3 \cdot 4 \cdot 5} a^5 x^{15} = 15,504 a^5 x^{15}.$$

**87.** If we denote the coefficients of the terms of the expansion by a series of  $c_s$ , then

$$(a + b)^n = a^n \left( 1 + \frac{b}{a} \right)^n = a^n + c_1 a^{n-1} b + c_2 a^{n-2} b^2 + c_3 a^{n-3} b^3 \dots$$

where

$$c_1 = n.$$

$$c_2 = \frac{n(n-1)}{1 \times 2}.$$

$$c_3 = \frac{n(n-1)(n-2)}{1 \times 2 \times 3}.$$

$$c_4 = \frac{n(n-1)(n-2)(n-3)}{1 \times 2 \times 3 \times 4}.$$

**88.** By representing the coefficients in this manner, a relation of the subscripts of  $c$  and the coefficients is established.

Taking as an example,  $c_3$ , note that the numerator has three factors and that the denominator is factorial 3.

Also note that

$$\begin{aligned}c_1 &= n. \\c_2 &= \frac{n(n-1)}{1 \cdot 2} = c_1 \frac{(n-1)}{2}. \\c_3 &= \frac{n(n-1)(n-2)}{1 \cdot 2 \cdot 3} = c_2 \frac{(n-2)}{3}. \\c_4 &= \frac{n(n-1)(n-2)(n-3)}{1 \cdot 2 \cdot 3 \cdot 4} = c_3 \frac{(n-3)}{4}.\end{aligned}$$

Each coefficient is equal to the preceding coefficient, multiplied by a fraction having a numerator one less, and a denominator one more, than those of the fraction for the preceding coefficient.

**EXAMPLE.**—Expand  $\left(2y - \frac{1}{2x}\right)^7$ .

$$c_1 = 7.$$

$$c_2 = c_1 \times \frac{6}{1} = 7 \times 6 = 42, \text{ or } \frac{7}{1} \times \frac{7-1}{1+1}$$

$$c_3 = c_2 \times \frac{5}{2} = 42 \times \frac{5}{2} = 105.$$

$$c_4 = c_3 \times \frac{4}{3} = 105 \times \frac{4}{3} = 140.$$

$$c_5 = c_4 \times \frac{3}{4} = 140 \times \frac{3}{4} = 105.$$

$$c_6 = c_5 \times \frac{2}{5} = 105 \times \frac{2}{5} = 42.$$

$$c_7 = c_6 \times \frac{1}{6} = 42 \times \frac{1}{6} = 7.$$

$$\begin{aligned}\left(2y - \frac{1}{2x}\right)^7 &= (2y)^7 + 7(2y)^6 \left(-\frac{1}{2x}\right) + 21(2y)^5 \left(-\frac{1}{2x}\right)^2 \\&+ 35(2y)^4 \left(-\frac{1}{2x}\right)^3 + 35(2y)^3 \left(-\frac{1}{2x}\right)^4 + 21(2y)^2 \left(-\frac{1}{2x}\right)^5 \\&+ 7(2y) \left(-\frac{1}{2x}\right)^6 + \left(-\frac{1}{2x}\right)^7. \\&= 128y^7 - 224y^6 \cdot \frac{1}{x} + 168y^5 \cdot \frac{1}{x^2} - 70y^4 \cdot \frac{1}{x^3} + 35y^3 \cdot \frac{1}{2x^4} \\&- 21y^2 \cdot \frac{1}{8x^5} + 7y \cdot \frac{1}{32x^6} - \frac{1}{128x^7}.\end{aligned}$$

**89. Pascal's Triangle.**—If the coefficients of  $(a+b)^0$ ,  $(a+b)^1$ ,  $(a+b)^2$ , etc., are arranged as shown, each coefficient is equal to the sum of the two coefficients which are nearest to the right and left of it in the line above.

				1															
				1	1														
				1	2	1													
				1	3	3	1												
				1	4	6	4	1											
				1	5	10	10	5	1										
				1	6	15	20	15	6	1									
				1	7	21	35	35	21	7	1								
				1	8	28	56	70	56	28	8	1							
				1	9	36	84	126	126	84	36	9	1						
				1	10	45	120	210	252	210	120	45	10	1					
				1	11	55	165	330	462	462	330	165	55	11	1				
1				1	12	66	220	495	792	924	792	495	220	66	12	1			

The second figures in each line show the value of  $n$  in each case.

This triangle can often be used to determine the coefficients without computing.

**90. Expressions as  $(a - b - c)^3$**  can be expanded directly by the binomial theorem.

$$\begin{aligned}
 (a - b - c)^3 &= [(a - b) - c]^3 = \\
 &= (a - b)^3 - 3(a - b)^2c + 3(a - b)c^2 - c^3 = \\
 &= a^3 - 3a^2b + 3ab^2 - b^3 - 3c(a^2 - 2ab + b^2) + 3ac^2 - 3bc^2 - c^3 = \\
 &= a^3 - 3a^2b + 3ab^2 - b^3 - 3a^2c + 6abc - 3b^2c + 3ac^2 - 3bc^2 - c^3.
 \end{aligned}$$

EXAMPLE.—Expand  $(a + b + c)^3$ .

$$\begin{aligned}
 (a + b + c)^3 &= [(a + b) + c]^3 = \\
 &= (a + b)^3 + 3(a + b)^2c + 3(a + b)c^2 + c^3 = \\
 &= a^3 + 3a^2b + 3ab^2 + b^3 + 3ac^2 + 6abc + 3b^2c + 3ac^2 + 3bc^2 + c^3.
 \end{aligned}$$

In the same manner,  $(a + b - c - d)^3$  can be expanded  $[(a + b) - (c + d)]^3$ . This method is quite a saving in time and effort.

**91. Multiplication by Detached Coefficients.**—Ordinary method of multiplication:

$$\begin{array}{r}
 4x^2 + 6x + 2 \\
 2x^2 - 5x - 1 \\
 \hline
 8x^4 + 12x^3 + 4x^2 \\
 - 20x^3 - 30x^2 - 10x \\
 - 4x^2 - 6x - 2 \\
 \hline
 8x^4 - 8x^3 - 30x^2 - 16x - 2
 \end{array}$$

Detached method:

$$\begin{array}{r}
 4 + 6 + 2 \\
 2 - 5 - 1 \\
 \hline
 8 + 12 + 4 \\
 - 20 - 30 - 10 \\
 - \quad 4 - 6 - 2 \\
 \hline
 8 - 8 - 30 - 16 - 2
 \end{array}$$

Using the numbers obtained above as coefficients for the terms of a power series in  $x$ , there results as the product,

$$8x^4 - 8x^3 - 30x^2 - 16x - 2.$$

Care must be taken that powers are in regular ascending or descending order. Arrange the terms of the multiplicand and multiplier in the same order, and supply 0 wherever any power is missing, as

$$3x^3 + 0 + 4x + 25.$$

### 92. Division by Detached Coefficients.

EXAMPLE.—Divide  $12x^4 + 7x^3 - 7x^2 + 15x - 3$  by  $4x^2 - 3x + 3$ .

$$\begin{array}{r}
 4 - 3 + 3 \overline{) 12 + 7 - 7 + 15 - 3} \quad \underline{3 + 4 - 1} \\
 \underline{12 - 9 + 9} \\
 + 16 - 16 + 15 \\
 \underline{+ 16 - 12 + 12} \\
 - 4 + 3 - 3 \\
 \underline{- 4 + 3 - 3}
 \end{array}$$

The quotient then is  $3x^2 + 4x - 1$ .

## MULTIPLICATION AND FACTORS

93. The product of two binomials having a common term, as

$$(x + a)(x + b) = x^2 + (a + b)x + ab:$$

The product in this case is equal to the sum of the square of the common term, the product of the sum of the unlike terms by the common term, and the product of the unlike terms.

EXAMPLE.

$$(x + 2)(x + 5) = x^2 + (2 + 5)x + 2 \cdot 5 = x^2 + 7x + 10.$$

94. The product of two binomials having similar terms, as

$$(2x - 5)(3x + 4):$$



The product must have a term in  $x^2$ , a term in  $x$ , and a numerical or absolute term.

The  $x^2$  term is the product of  $2x$  and  $3x$ .

The term in  $x$  is the sum of the partial products,  $-5 \times 3x$ , and  $2x \times 4$ , called the cross-products.

The absolute term is the product of  $-5$  and  $4$ .

$$\begin{array}{r} 2x - 5 \\ 3x + 4 \\ \hline 6x^2 - 7x - 20 \end{array}$$

## 95. Squaring Polynomials.

EXAMPLE.

$$(a + b + c + d + \dots)^2 = a^2 + b^2 + c^2 + d^2 + \dots + 2a(b + c + d + \dots) + 2b(c + d + \dots) + 2c(d + \dots) + 2d(\dots) + \dots$$

This expression is formed by adding the squares of all the terms taken separately, and twice the product of each term by the sum of the terms that follow.

**96. Monomial Factors.**—A monomial is a factor of a polynomial if it is present *in every term* of the polynomial. Thus  $x$  is a monomial of  $ax + bx + cx$ . Then  $(a + b + c)x$  is the factored expression.

The terms of an expression can be rearranged to take out monomial factors by grouping those terms having a common factor, as

$$ax + ay + bx + by = a(x + y) + b(x + y) = (a + b)(x + y).$$

The factor  $x + y$  in the center expression is multiplied by  $a$  and added to the same factor multiplied by  $b$ , which is equivalent to the sum of them or  $a + b$  times the factor  $(x + y)$  as shown.

Frequently, the rearrangement is not so evident for taking out the monomial factors as the following example will indicate:

EXAMPLE.—Factor  $a^3 + 2a^2b + 2ab^2 + b^3$ .

Change  $2a^2b$  to  $a^2b + a^2b$ , and  $2ab^2$  to  $ab^2 + ab^2$ . Then

$$\begin{aligned} a^3 + a^2b + a^2b + ab^2 + ab^2 + b^3 &\text{ can be written} \\ a^2(a + b) + ab(a + b) + b^2(a + b), &\text{ or} \\ (a + b)(a^2 + ab + b^2), &\text{ the factored form.} \end{aligned}$$

**97. Trinomials Which are Perfect Squares.**

$$a^2 + 2ab + b^2 = (a + b)^2.$$

$$a^2 - 2ab + b^2 = (a - b)^2.$$

$$a^2 + 4ab + 4b^2 = (a + 2b)^2.$$

$$9a^2 + 12ab + 4b^2 = (3a + 2b)^2.$$

$$4a^4 + 4a^2 + 1 = (2a^2 + 1)^2.$$

If twice the product of the square roots of two of the terms of a trinomial is equal to the other term, the trinomial is a perfect square, as in

$$9a^2 + 12ab + 4b^2 = (3a + 2b)^2, \text{ where}$$

the square root of the first term is  $3a$ , the square root of the last term is  $2b$ , and twice the product of  $3a$  and  $2b$  is  $12ab$ , which is the second term of the trinomial.

**98. The Difference of Two Powers.**

$$a^2 - b^2 = (a - b)(a + b).$$

$$a^3 - b^3 = (a - b)(a^2 + ab + b^2).$$

$$a^4 - b^4 = (a - b)(a^3 + a^2b + ab^2 + b^3).$$

$$a^5 - b^5 = (a - b)(a^4 + a^3b + a^2b^2 + ab^3 + b^4).$$

$$a^n - b^n = (a - b)(a^{n-1} + a^{n-2}b + a^{n-3}b^2 + \dots + b^{n-1}).$$

$$a^n - b^n = (a + b)(a^{n-1} - a^{n-2}b + a^{n-3}b^2 - \dots + b^{n-1}) \text{ if } n \text{ is even.}$$

$$a^{2n} - b^{2n} = (a^n - b^n)(a^n + b^n) \text{ [as } 2n \text{ is even].}$$

**99. The Sum of Two Powers.**

$$a^2 + b^2 = (a + b\sqrt{-1})(a - b\sqrt{-1}).$$

$$a^3 + b^3 = (a + b)(a^2 - ab + b^2).$$

$$a^4 + b^4 = (a^2 + ab\sqrt{2} + b^2)(a^2 - ab\sqrt{2} + b^2).$$

$$a^5 + b^5 = (a + b)(a^4 - a^3b + a^2b^2 - ab^3 + b^4).$$

$$a^n + b^n = (a + b)(a^{n-1} - a^{n-2}b + a^{n-3}b^2 - \dots + b^{n-1}) \text{ if } n \text{ is odd.}$$

**100. Trinomial Form ( $x^2 + bx + c$ ).**

$$x^2 + bx + c = (x + p)(x + q)$$

where  $p$  and  $q$  are two numbers whose sum is  $b$  and whose product is  $c$ , or in symbols,

$$p + q = b, \text{ and } pq = c.$$

EXAMPLE.—Factor  $x^2 + x - 30$ .

The sum  $p + q = 1$ .

The product  $pq = -30$ .

The only factors of  $-30$  whose sum equals  $1$  is  $(6)(-5)$ .

Therefore,

$$x^2 + x - 30 = (x + 6)(x - 5).$$

**101. Factoring special trinomials of the form ( $ax^2 + bx + c$ ),**  
as  $3x^2 + 11x - 4$ ;

Since  $3x^2$  is the product of the first terms of the binomial factors, the first-term factors, each containing  $x$ , are  $3x$  and  $x$ .

Since  $-4$  is the product of the last terms of the binomial factors, these must have unlike signs, and the only possible last terms are  $4$  and  $-1$ ,  $-4$  and  $1$ , or  $2$  and  $-2$ .

Hence, associating these pairs of factors of  $-4$  with  $3x$  and  $x$  in all possible ways, we have

$$\begin{pmatrix} 3x+4 \\ x-1 \end{pmatrix} \begin{pmatrix} 3x-1 \\ x+4 \end{pmatrix} \begin{pmatrix} 3x-4 \\ x+1 \end{pmatrix} \begin{pmatrix} 3x+1 \\ x-4 \end{pmatrix} \begin{pmatrix} 3x+2 \\ x-2 \end{pmatrix} \begin{pmatrix} 3x-2 \\ x+2 \end{pmatrix}$$

Of these, we select *by trial* the pair that will give  $11x$  (the middle term), for the algebraic sum of the cross-products. It is evident that these will be the second pair, or

$$(3x-1) \text{ and } (x+4).$$

Observe that when the sign of the last term of the trinomial is  $+$ , the signs of the last terms of the factors must be *both*  $+$ , or *both*  $-$ , and like the sign of the middle term of the trinomial.

Also, when the sign of the last term is  $-$ , the sign of the last term of one factor must be  $+$  and of the other,  $-$ .

### 102. Binomials and Trinomials Reducible to the Form $(a^2 - b^2)$ .

Some expressions are reducible to the difference of two squares (Art. 98) by the addition and subtraction of certain terms, as  $a^4 + 4b^4$ . Adding and subtracting  $4a^2b^2$  leaves the value unchanged. Thus,

$$a^4 + 4a^2b^2 + 4b^4 - 4a^2b^2 = a^4 + 4b^4. \text{ But}$$

$$a^4 + 4a^2b^2 + 4b^4 - 4a^2b^2 = (a^4 + 4a^2b^2 + 4b^4) - 4a^2b^2,$$

which can be factored as the difference of two squares, thus,  $a^4 + 4a^2b^2 + 4b^4 - 4a^2b^2 = (a^2 + 2ab + 2b^2)(a^2 + 2ab - 2b^2)$ .

EXAMPLE.—Factor  $a^4 + a^2b^2 + b^4$ .

Add and subtract  $a^2b^2$ .

$$\begin{aligned} a^4 + a^2b^2 + b^4 &= a^4 + 2a^2b^2 + b^4 - a^2b^2 = \\ (a^4 + 2a^2b^2 + b^4) - a^2b^2 &= (a^2 + ab + b^2)(a^2 - ab + b^2). \end{aligned}$$

Trinomials of the type,

$$p^2x^4 + qx^2y^2 + r^2y^4,$$

can be factored by this method, if  $\pm 2pr - q$  is a perfect square.

### 103. Quadrinomials Reducible to Form $(a^2 - b^2)$ (Art. 98).

$$a^2 + 2ab + b^2 - c^2 = (a^2 + 2ab + b^2) - c^2 = (a + b + c)(a + b - c).$$

$$a^2 - b^2 + 2bc - c^2 = a^2 - (b^2 - 2bc + c^2) = (a - b + c)(a + b - c).$$

$$\begin{aligned} 4a^2 - b^2 + 9x^2 - 4y^2 - 12ax + 4by &= (\text{rearranging}) 4a^2 - 12ax + 9x^2 - b^2 \\ + 4by - 4y^2 &= (4a^2 - 12ax + 9x^2) - (b^2 - 4by + 4y^2) = (2a - 3x)^2 - (b - 2y)^2 \\ &= (2a - 3x + b - 2y)(2a - 3x - b + 2y). \end{aligned}$$

**104. Rearranging Terms.**—By rearranging the terms of a polynomial, factors may often be found when they would otherwise escape notice.

**EXAMPLE.**—Factor  $x^3 - 7x^2y + 14xy^2 - 8y^3$ .

Rearranging,

$$= (x^3 - 8y^3) - (7x^2y - 14xy^2).$$

$$= (x - 2y)(x^2 + 2xy + 4y^2) - 7xy(x - 2y).$$

$$= (x - 2y)(x^2 - 5xy + 4y^2) = (x - 2y)(x - y)(x - 4y).$$

**105. Polynomials Reducible to the Form  $(ax^2 + bx + c)$ .**—Rearranging the terms so as to conform to the type  $(ax^2 + bx + c)$  will often bring results.

**EXAMPLE.**—Factor  $3x^2 - 6xy + 3y^2 - 10x + 10y + 3$ .

$$3x^2 - 6xy + 3y^2 - 10x + 10y + 3 =$$

$$3(x^2 - 2xy + y^2) - 10(x - y) + 3 =$$

$$3(x - y)^2 - 10(x - y) + 3 =$$

$$[3(x - y) - 1][(x - y) - 3] =$$

$$(3x - 3y - 1)(x - y - 3).$$

**106. General Method of Finding Binomial Factors.**—If a polynomial in  $x$ , having positive integral exponents, reduces to 0, when an integer  $r$  is substituted for  $x$ , the polynomial is exactly divisible by  $x - r$ . For, if the product of two factors is 0, at least one of the factors must be 0, or a number equal to 0. It may be shown, however, that  $r$  must be a factor of the absolute term.

**EXAMPLE.**—Factor  $x^3 - x^2 - 4x + 4$ .

When  $x = 1 = r$ ,

$$x^3 - x^2 - 4x + 4 = 1 - 1 - 4 + 4 = 0.$$

$\therefore (x - r)$  or  $(x - 1)$  is a factor.

$$\frac{x^3 - x^2 - 4x + 4}{x - 1} = x^2 - 4 = (x - 2)(x + 2).$$

$$\therefore x^3 - x^2 - 4x + 4 = (x - 1)(x - 2)(x + 2).$$

**EXAMPLE.**—Find the factors of  $17x^3 - 14x^2 - 37x - 6$ .

Since the sum of the coefficients is not 0,

$(x - 1)$  is not a factor.

When  $x = -1 = r$ , then

$$17x^3 - 14x^2 - 37x - 6 = -17 - 14 + 37 - 6 = 0.$$

$\therefore x - (-1)$  or  $x + 1$  is a factor.

**NOTE.**—Only factors of the absolute term (6 in the above) need be substituted for  $x$ , and it is well to begin with the smallest factor of the absolute term.

For more complete information regarding the factoring of polynomials, see Chap. X.

## 107. Miscellaneous Forms of Division.

$$\frac{x^3 - y^3}{x - y} = x^2 + xy + y^2.$$

$$\frac{x^3 - y^3}{x - y} = x^2 + xy + y^2.$$

$$\frac{x^4 - y^4}{x - y} = x^3 + x^2y + xy^2 + y^3.$$

$$\frac{x^5 - y^5}{x - y} = x^4 + x^3y + x^2y^2 + xy^3 + y^4.$$

$$\frac{x^2 - y^2}{x + y} = x - y.$$

$$\frac{x^3 - y^3}{x + y} = x^2 - xy + y^2 + \frac{-2y^3}{x + y}.*$$

$$\frac{x^4 - y^4}{x + y} = x^3 - x^2y + xy^2 - y^3.$$

$$\frac{x^5 - y^5}{x + y} = x^4 - x^3y + x^2y^2 - xy^3 + y^4 + \frac{-2y^5}{x + y}.*$$

$$\frac{x^2 + y^2}{x - y} = x + y + \frac{2y^2}{x - y}.*$$

$$\frac{x^3 + y^3}{x - y} = x^2 + xy + y^2 + \frac{2y^3}{x - y}.*$$

$$\frac{x^4 + y^4}{x - y} = x^3 + x^2y + xy^2 + y^3 + \frac{2y^4}{x - y}.*$$

$$\frac{x^5 + y^5}{x - y} = x^4 + x^3y + x^2y^2 + xy^3 + y^4 + \frac{2y^5}{x - y}.*$$

$$\frac{x^2 + y^2}{x + y} = x - y + \frac{2y^2}{x + y}.*$$

$$\frac{x^3 + y^3}{x + y} = x^2 - xy + y^2.$$

$$\frac{x^4 + y^4}{x + y} = x^3 - x^2y + xy^2 - y^3 + \frac{2y^4}{x + y}.*$$

$$\frac{x^5 + y^5}{x + y} = x^4 - x^3y + x^2y^2 - xy^3 + y^4.$$

\* NOTE.—In these cases, if  $y$  is sufficiently small, the fractional part of the quotient may be disregarded.

EXAMPLE.—If  $x + a^3 = 1 - ax$ , where  $a = .01$ , find  $x$ .

$$x + ax = 1 - a^3.$$

$$(1 + a)x = 1 - a^3.$$

$$x = \frac{1 - a^3}{1 + a}$$

From formula,

$$\begin{aligned} \frac{1 - a^3}{1 + a} &= 1 - a + a^2 + \frac{-2(.01)^3}{1 + a} \\ &= 1 - .01 + .0001 + \frac{(-2)(.000001)}{1.01} \end{aligned}$$

The fraction on the right side may be discarded. Then

$$x = 1 - .01 + .0001 = .9901.$$

$x^n - y^n$  is always divisible by  $x - y$ .

$x^n - y^n$  is divisible by  $x + y$  only when  $n$  is even.

$x^n + y^n$  is never divisible by  $x - y$ .

$x^n + y^n$  is divisible by  $x + y$  only when  $n$  is odd.

When  $x - y$  is the divisor, the signs in the quotient are all plus.

When  $x + y$  is the divisor, the signs in the quotient are alternately plus and minus.

**108. General Numerical Check of Addition, Subtraction, Multiplication, and Division.**—The check consists of the substitution of  $x = 1$  in the given expressions and the answer, which then becomes a numerical operation. If the algebraic operation is correctly done, the numerical operation will also be correct. Only multiplication and division will be shown.

$$x^2 - 2x + 5 \quad x = 1 \text{ substituted gives } 4$$

$$x^2 + 3x - 1 \quad x = 1 \text{ substituted gives } 3$$

$$\frac{x^4 - 2x^3 + 5x^2}{12}$$

$$+ 3x^3 - 6x^2 + 15x$$

$$- x^2 + 2x - 5$$

$$x^4 + x^3 - 2x^2 + 17x - 5 \quad x = 1 \text{ substituted gives } 12.$$

$$x + 5 \mid 3x^2 + 22x + 35 \mid 3x + 7 \text{ Ans.}$$

Substituting  $x = 1$  in the dividend,

$$3 + 22 + 35 = 60.$$

Substituting  $x = 1$  in the divisor (provided the divisor does not become zero),

$$1 + 5 = 6$$

Substituting  $x = 1$  in the quotient,  
 $3 + 7 = 10.$

Checking,

$$\frac{60}{6} = 10.$$

**109. The highest common factor** of two or more polynomials is the factor of the highest degree common to these expressions.

EXAMPLE.—Find H.C.F. of  $12a^4b^2c$  and  $32a^2b^3c^3$ .

The greatest arithmetical common divisor or highest common factor of 12 and 32 is 4.

The highest common factor of  $a^4b^2c$  and  $a^2b^3c^3$  is  $a^2b^2c$ .

Hence, H.C.F. of  $12a^4b^2c$  and  $32a^2b^3c^3$  is  $4a^2b^2c$ .

RULE.—Multiply the highest common factor of the numerical factors by each common literal factor with the least exponent it has in any of the expressions.

EXAMPLE.—Find H.C.F. of  $3x^3 - 3xy^2$  and  $6x^3 - 12x^2y + 6xy^2$ .

$$3x^3 - 3xy^2 = 3x(x + y)(x - y).$$

$$6x^3 - 12x^2y + 6xy^2 = 2 \cdot 3x(x - y)(x - y).$$

$$\therefore \text{H.C.F.} = 3x(x - y).$$

**110. Highest Common Factor (Euclidean Method).**—The H.C.F. of two polynomials in one variable may be found as follows: First, divide the expression of the higher degree by the one of lower degree. Second, divide the latter expression by the remainder of the first operation. Continue in this manner until an exact divisor is found, which will be the H.C.F.

EXAMPLE.—Find the H.C.F. of  $x^4 - 5x^3 + 4x^2 + 10x - 12$  and  $x^3 - 3x^2 - 3x + 9$ .

$$\begin{array}{r} x^3 - 3x^2 - 3x + 9 \overline{) x^4 - 5x^3 + 4x^2 + 10x - 12} \phantom{+ 9} \\ \underline{x^4 - 3x^3 - 3x^2 + 9x} \phantom{- 12} \\ -2x^3 + 7x^2 + x - 12 \\ \underline{-2x^3 + 6x^2 + 6x - 18} \\ x^2 - 5x + 6 \overline{) x^3 - 3x^2 - 3x + 9} \phantom{+ 12} \\ \underline{x^3 - 5x^2 + 6x} \phantom{+ 9} \\ 2x^2 - 9x + 9 \\ \underline{2x^2 - 10x + 12} \\ x - 3 \end{array}$$

$$x^2 - 5x + 6 = (x - 3)(x - 2).$$

Since  $x - 3$  (the last remainder) will exactly divide

$x^2 - 5x + 6$  (the last divisor),  $x - 3$  is the H.C.F. of

$x^4 - 5x^3 + 4x^2 + 10x - 12$  and  $x^3 - 3x^2 - 3x + 9$ .

**111. The lowest common multiple** of two or more polynomials is the expression of lowest degree which can be divided by each of them without a remainder, and is the product of all their different prime factors, each factor being used the greatest number of times it occurs in any one of the expressions.

**EXAMPLE.**—Find the L.C.M. of  $x^2 - 2xy + y^2$ ,  $y^2 - x^2$ , and  $x^3 - y^3$ .

$$x^2 - 2xy + y^2 = (x - y)(x - y).$$

$$y^2 - x^2 = -(x + y)(x - y).$$

$$x^3 + y^3 = (x + y)(x^2 - xy + y^2).$$

$\therefore$  L.C.M. =  $(x - y)^2(x + y)(x^2 - xy + y^2)$ , by factoring the expressions into their prime factors and proceeding as outlined above.

**112. Another method of finding L.C.M.** of two expressions is to divide one of the expressions by their H.C.F. and multiply the quotient so obtained by the other expression.

**EXAMPLE.**—Find the L.C.M. of  $x^3 - 2x^2 + x + 4$  and

$$x^3 - 3x^2 + 2x + 6.$$

The H.C.F. of the two expressions is  $x + 1$ .

$$\frac{x^3 - 2x^2 + x + 4}{x + 1} = x^2 - 3x + 4.$$

$$\text{L.C.M.} = (x^2 - 3x + 4)(x^3 - 3x^2 + 2x + 6).$$

**113. Operations with Zero.**—All numerical operations, with one exception, can be made with zero, *i.e.*;

$$\text{Adding zero,} \quad a + 0 = a.$$

$$\text{Subtracting zero,} \quad a - 0 = a.$$

$$\text{Multiplying by zero,} \quad a \times 0 = 0.$$

$$\text{Raising to zero power,} \quad a^0 = 1.$$

$$\text{Dividing zero by any number,} \quad \frac{0}{a} = 0.$$

But we cannot divide by zero.

**114. Fractions Which Reduce to  $\frac{0}{0}$  When  $x$  Approaches  $a$ .**

$$y = \frac{a^3 - x^3}{a^2 - x^2}, \quad y = \frac{2(a - x)^2}{3(a^2 - x^2)}, \quad y = \frac{2(a^2 - x^2)}{3(a - x)^2}.$$

These fractions have no meaning when  $x = a$ ; but we may ask how their values behave when  $x$  approaches  $a$ .



The factor  $a - x$ , which approaches zero when  $x$  approaches  $a$ , being common to both numerator and denominator, may be cancelled, provided  $x \neq a$ , which gives

$$y = \frac{a^2 + ax + x^2}{a + x}, \quad y = \frac{2(a - x)}{3(a + x)}, \quad y = \frac{2(a + x)}{3(a - x)}.$$

If  $x$  approaches  $a$  as a limit, we have in the three cases, respectively,

$$y \text{ approaches } \frac{3a}{2}, \quad y \text{ approaches } \frac{0}{6a}, \quad y \text{ becomes infinite.}$$

In addition to this indeterminate form  $\frac{0}{0}$ , there are other indeterminate forms, such as

$$0 \times \infty, \quad \frac{\infty}{\infty}, \quad 0^0, \quad \infty^0, \quad \infty - \infty.$$

### RADICALS

**115.** A radical is the root of a number and is indicated by the radical sign ( $\sqrt{\quad}$ ) written before the number.

If the root can be extracted exactly, the radical is rational, and if the root cannot be exactly extracted, the radical is irrational and is called a *surd*.

An indicated even root of a negative number is an imaginary number, as  $\sqrt{-4}$ , but all other numbers are real.

All even roots of a positive number may be positive or negative, but it is usual to use only the roots having the prefixed sign.

Always reduce a radical to its simplest form, as

$$\begin{aligned} \sqrt{25a^4b} &= \sqrt{25a^4} \cdot \sqrt{b} = 5a^2\sqrt{b}. \\ \sqrt[4]{48a^4b^{10}} &= \sqrt[4]{16a^4b^8} \cdot \sqrt[4]{3ab^2} = 2ab^2\sqrt[4]{3ab^2}. \end{aligned}$$

Separate the radical into two factors, one of which is its highest rational factor. Extract the indicated root of the rational factor, multiply the result by the coefficient, if any, of the given radical, and place the product as the coefficient of the irrational factor.

$$\sqrt[6]{9a^2} = \sqrt[6]{(3a)^2} = (3a)^{\frac{1}{3}} = (3a)^{\frac{1}{3}} = \sqrt[3]{3a}.$$

**116.** To reduce a quantity under the radical which is fractional, remove the denominator by making its exponent divisible by the exponent of the radical. This may be done by multiplying both numerator and denominator by the same factor, which does

not change the value of the fraction, and then the denominator can be taken from under the radical.

EXAMPLE.—Reduce  $\sqrt{\frac{a^2}{2x^3}}$ .

Multiplying both numerator and denominator by  $2x$ ,

$$\sqrt{\frac{a^2 \times 2x}{2x^3 \times 2x}} = \sqrt{\frac{a^2}{4x^4}} \times \sqrt{2x} = \frac{a}{2x^2} \sqrt{2x}.$$

**117.** To change the order of a surd, remember that the exponent and index bear the same relation as the numerator and denominator of a fraction, and both may be multiplied or divided by the same number without changing the value of the radical.

$2a\sqrt{5b}$ , if reduced to an entire surd, is equal to  $\sqrt{4a^2} \cdot \sqrt{5b}$   
 $= \sqrt{4a^2 \times 5b} = \sqrt{20a^2b}$ .

To reduce radicals, as  $\sqrt[4]{3}$ ,  $\sqrt{2}$ ,  $\sqrt[3]{4}$ , to the same degree,

$$\sqrt[4]{3} = (3)^{\frac{1}{4}} = (3)^{\frac{3}{12}} = \sqrt[12]{3^3} = \sqrt[12]{27}.$$

$$\sqrt{2} = (2)^{\frac{1}{2}} = (2)^{\frac{6}{12}} = \sqrt[12]{2^6} = \sqrt[12]{64}.$$

$$\sqrt[3]{4} = (4)^{\frac{1}{3}} = (4)^{\frac{4}{12}} = \sqrt[12]{4^4} = \sqrt[12]{256}.$$

**118. Addition and Subtraction of Radicals.**—Several radical terms can be united into one term by addition or subtraction, only when they contain the same radical.

EXAMPLE.

$$\sqrt{50} + 2\sqrt[5]{8} + 6\sqrt{\frac{1}{2}}$$

$$\sqrt{50} = 5\sqrt{2}$$

$$2\sqrt[5]{8} = 2\sqrt{\frac{1}{2}}$$

$$6\sqrt{\frac{1}{2}} = 3\sqrt{2}$$

$$10\sqrt{2}.$$

**119. Multiplication of Radicals.**—First, reduce the radicals to the same degree, that is, to the same exponent. Then multiply the coefficients together for the coefficient of the product, and the factors under the radical signs for the radical factor of the product, and simplify the result.

EXAMPLES.— $\sqrt{a} \times \sqrt[3]{a} = \sqrt[6]{a^3} \times \sqrt[6]{a^2} = \sqrt[6]{a^5}$ .

$$\sqrt{7} \times \sqrt{5} = \sqrt{35}.$$

$$5\sqrt{3} \times 2\sqrt{15} = 10\sqrt{45} = 10\sqrt{9 \times 5} = 30\sqrt{5}.$$

$$2\sqrt{2} + 3\sqrt{3}$$

$$\underline{5\sqrt{2} - 2\sqrt{3}}$$

$$20 + 15\sqrt{6}$$

$$\underline{- 4\sqrt{6} - 18}$$

$$20 + 11\sqrt{6} - 18 = 2 + 11\sqrt{6}.$$

$$\sqrt{2} \times 3\sqrt[3]{4} = \sqrt[6]{2^3} \times 3\sqrt[6]{4^2} = \sqrt[6]{2^3} \times 3\sqrt[6]{2^4} = 3\sqrt[6]{2^7} = 6\sqrt[6]{2}.$$

**120. Division of Radicals.**—If a single radical is to be divided by a single radical, reduce the radicals to the same degree, that is, to the same exponent, and to the quotient of the coefficients, annex the quotient of the radical factors, and simplify.

EXAMPLE.

$$a\sqrt{b} \div x\sqrt{y}.$$

$$\frac{a\sqrt{b}}{x\sqrt{y}} = \frac{a}{x} \sqrt{\frac{b}{y}}.$$

It greatly simplifies a radical to be put in fractional exponent form, and all radicals, other than square root or cube root, should be handled in this manner.

**121. Fractional Radicals.**—If the denominator of a fraction is of the form  $\sqrt{a} \pm \sqrt{b}$ , multiply both the numerator and the denominator by  $\sqrt{a} \mp \sqrt{b}$  to rationalize the denominator.

$$\frac{\sqrt{a} + \sqrt{b}}{\sqrt{a} - \sqrt{b}} = \frac{(\sqrt{a} + \sqrt{b})(\sqrt{a} + \sqrt{b})}{(\sqrt{a} - \sqrt{b})(\sqrt{a} + \sqrt{b})} = \frac{a + b + 2\sqrt{ab}}{a - b}.$$

Bear in mind, also, that

$$(a + \sqrt{b})(a - \sqrt{b}) = a^2 - b.$$

This relation will often simplify or rationalize the denominator of a fraction. Also,

$$\begin{aligned} \frac{1 + \sqrt{2} + \sqrt{3}}{1 + \sqrt{2} - \sqrt{3}} &= \frac{1 + \sqrt{2} + \sqrt{3}}{(1 + \sqrt{2}) - \sqrt{3}} \cdot \frac{1 + \sqrt{2} + \sqrt{3}}{1 + \sqrt{2} + \sqrt{3}} = \\ &= \frac{6 + 2\sqrt{2} + 2\sqrt{3} + 2\sqrt{6}}{(1 + 2\sqrt{2} + 2) - 3} = \frac{3 + \sqrt{2} + \sqrt{3} + \sqrt{6}}{\sqrt{2}} \cdot \frac{\sqrt{2}}{\sqrt{2}} \\ &= \frac{3\sqrt{2} + 2 + \sqrt{6} + 2\sqrt{3}}{2}. \end{aligned}$$

**122. Powers and Roots of Radicals.**—Reduce to fractional exponents first.

**EXAMPLES.**

$$\text{Cube } 2\sqrt{ax^3} = 2^3(ax^3)^{\frac{1}{2}} = 8a^{\frac{3}{2}}x^{\frac{3}{2}} = 8\sqrt{a^3x^3} = 8ax^{\frac{1}{2}}\sqrt{ax}.$$

$$\text{Square } 3\sqrt[6]{x^5} = 9(x^5)^{\frac{1}{2}} = 9x^{\frac{5}{2}} = 9x\sqrt[3]{x^2}.$$

Cube  $\sqrt{2} + 1$ . Use the binomial expansion in such cases.

$$\begin{aligned} (\sqrt{2} + 1)^3 &= (\sqrt{2})^3 + 3(\sqrt{2})^2 \cdot 1 + 3\sqrt{2} \cdot 1^2 + 1^3 \\ &= 2\sqrt{2} + 6 + 3\sqrt{2} + 1 = 7 + 5\sqrt{2}. \end{aligned}$$

$$\text{Cube root of } -27\sqrt{ax} = \sqrt[3]{[-27\sqrt{ax}]} = (-27)^{\frac{1}{3}}(ax)^{\frac{1}{3}} = -3\sqrt[6]{ax}.$$

$$\text{Square root of } 8 + 2\sqrt{12}.$$

The terms of the square root of a binomial surd that is a perfect square may be obtained by dividing the irrational term by 2, and then separating the quotient into two factors, the sum of whose squares is the rational term. Generally,

$$(\sqrt{x} + \sqrt{y})^2 = x + 2\sqrt{xy} + y = x + y + 2\sqrt{xy},$$

where  $x$  and  $y$  may be any numbers.

Therefore, if we may divide the radical by 2, and separate the resulting quotient into two factors which when squared separately and added give the rational term of the surd, then the surd is the perfect square of the sum of the two factors. Thus,  $8 + 2\sqrt{12}$  may be written  $6 + 2\sqrt{12} + 2$ , whence, by comparison with the general equation above,

$$\begin{aligned} x &= 6, \quad y = 2, \quad 2\sqrt{xy} = 2\sqrt{12} = 2\sqrt{6 \cdot 2} = 2\sqrt{6} \cdot \sqrt{2}. \\ \therefore (\sqrt{6} + \sqrt{2})^2 &= 6 + 2\sqrt{12} + 2 = 8 + 2\sqrt{12}. \\ \text{or } \sqrt{8 + 2\sqrt{12}} &= \sqrt{6} + \sqrt{2} \end{aligned}$$

**EXAMPLE.**—Find the square root of  $14 + 8\sqrt{3}$ .

$$\frac{8\sqrt{3}}{2} = 4\sqrt{3} = \sqrt{48} = \sqrt{6} \times \sqrt{8}.$$

$$8 + 6 = 14, \text{ so that}$$

$$14 + 8\sqrt{3} = (\sqrt{6} + \sqrt{8})^2 \text{ or } \sqrt{6} + \sqrt{8}, \text{ is the square root of } 14 + 8\sqrt{3}.$$

## 123. Powers and Roots.

$a^n = a \cdot a \cdot a \cdot a \dots$  to  $n$  factors.

$$a^{-n} = \frac{1}{a^n}.$$

$$a^m \cdot a^n = a^{m+n}.$$

$$\frac{a^m}{a^n} = a^{m-n}.$$

$$(a^m)^n = a^{mn}.$$

$$(ab)^n = a^n b^n.$$

$$\left(\frac{a}{b}\right)^n = \frac{a^n}{b^n}.$$

$$(\sqrt[n]{a})^n = \sqrt[n]{a^n} = a.$$

$$a^{\frac{1}{n}} = \sqrt[n]{a}.$$

$$a^{\frac{m}{n}} = \sqrt[n]{a^m} = (\sqrt[n]{a})^m.$$

$$\sqrt[n]{ab} = \sqrt[n]{a} \cdot \sqrt[n]{b}.$$

$$\sqrt[n]{\frac{a}{b}} = \frac{\sqrt[n]{a}}{\sqrt[n]{b}}.$$

$$\sqrt[n]{\sqrt[n]{a}} = \sqrt[n^2]{a}.$$

$$a^0 = a^{n-n} = \frac{a^n}{a^n} = 1.$$

$$a^{-n} \cdot a^n = 1.$$

$$\frac{a^{-m}}{b^{-n}} = \frac{\frac{1}{a^m}}{\frac{1}{b^n}} = \frac{1}{a^m} \times \frac{b^n}{1} = \frac{b^n}{a^m}.$$

$$\sqrt[n]{\frac{1}{a^m}} = \sqrt[n]{a^{-m}} = a^{-\frac{m}{n}}.$$

$$\sqrt[n]{\sqrt[n]{\frac{1}{a^{mr}}}} = \sqrt[n]{\sqrt[n]{a^{-mr}}} = \sqrt[n]{a^{-\frac{mr}{n}}} = a^{-\frac{mr}{ns}}.$$

$$\sqrt[n]{a^m} = \sqrt[n^p]{a^{mp}}.$$

$$\sqrt[n]{a} \cdot \sqrt[n]{a} = \sqrt[n]{a \cdot a} = \sqrt[n]{a^2}.$$

$$(a + b)^n = a^n \left(1 + \frac{b}{a}\right)^n.$$

## CHAPTER IV

### FUNCTIONS AND GRAPHS, AND THE STATEMENT OF PROBLEMS IN THE FORM OF EQUATIONS

#### FUNCTIONS AND VARIABLES

**124. Functions.**—A variable  $y$  is said to be a function of another variable  $x$  if when a value of  $x$  is given, the value of  $y$  is determined.

EXAMPLE.

$$y = mx + 5.$$

Here,  $y$  is a function of  $x$ , or  $mx + 5$  being equal to  $y$  is a function of  $x$ .

A variable is a quantity which, throughout a given discussion, assumes a number of different values.

Functions are also represented by symbols, as  $F(x)$ ,  $f(x)$ , where  $F(x)$  and  $f(x)$  are expressions containing  $x$ , as  $bx + c$ .

EXAMPLE.—A cistern that already contains 300 gallons of water is filled at the rate of 50 gallons per hour.

In  $x$  hours the cistern will receive  $50x$  gallons of water. Since it already contains 300 gallons and we denote the total amount of water by  $y$ , we will have

$$y = 50x + 300.$$

The quantity of water is a function of the time, or  $y$  is a function of  $x$ ; that is,  $y = f(x)$ , where

$$f(x) \text{ means } 50x + 300.$$

If we have a body projected upward with an initial velocity  $v_0$  consider  $s$  the distance above the starting point, and  $t$  the time in seconds, we have

$$s = v_0t - 16t^2$$

or the distance  $s$  is a function of the time  $t$ .

A vessel of water is being heated. The temperature is a function of the time.

The speed of a starting train is taken for every second by a speedometer. The speed is a function of the time.

The area of a square is a function of the side.  $A = x^2$ .

The volume of a sphere is a function of its radius.

The volume of a given weight of water is a function of its temperature.

**125. Graphs of Equations.**—Restating the definition of a function as a quantity  $y$  which varies in a definite relation to  $x$  as  $x$  varies,  $y$  is, then, a function of  $x$ .

$x$  is the independent variable and  $y$  is the dependent variable.

Points along the base line, or  $X$ -axis, represent values of the independent variable  $x$ , while the varying height of the curve above the  $X$ -axis represents the values of the dependent variable  $y$  for every corresponding value of  $x$ . In most cases, this height is a varying quantity and shows how the second or dependent variable varies with relation to the first or independent variable.

This is the usual procedure: Plot the independent variable as abscissa and the dependent variable as ordinates. Figure 3 shows graphically the manner in which the function varies for different values of the independent variable. The height of the ordinate is the measure of the value of the dependent variable or function for a particular value of  $x$ .

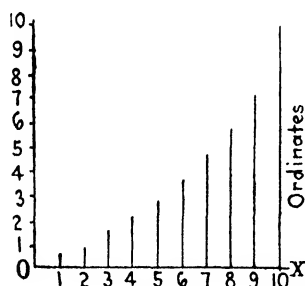

FIG. 3.

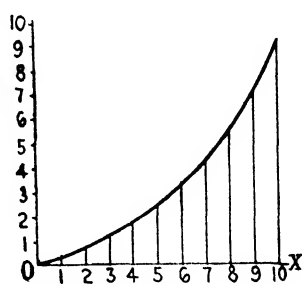

FIG. 4.

In order to get the height of the ordinates and to dispense with the necessity of drawing them in each case, a curved line is drawn connecting the upper ends of the ordinates, as shown in Fig. 4.

Do not, therefore, think of a curve or locus as a mysterious representation of an equation but as a means of getting the height of the ordinates for a particular value of the independent variable. Bear in mind that it is the varying heights with which we are concerned.

If we have an expression, as

$$x^2 + 3x + 3,$$

the value of the expression is dependent upon the value we give  $x$ . The expression is said to be a function of  $x$ . What we really do when we make a graph of the expression is to plot the values of the expression as ordinates for different values of  $x$ . Actually both are in terms of  $x$ . If the reader gets this point of view, graphical relations become more clear (see Fig. 5).

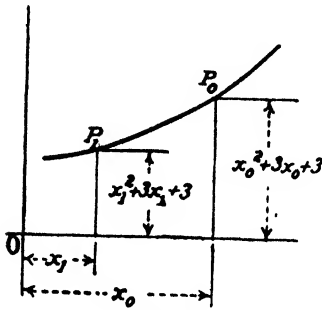

FIG. 5.

Now the expression may be represented by  $y$  or by any other variable, and we then make the equality,

$$y = x^2 + 3x + 3,$$

or

$$\beta = x^2 + 3x + 3.$$

This, however, does not change the original relation as stated in the beginning and as shown by the figure.

**126. First-degree Functions.**—First-degree functions are often called linear functions because the graph of such a function is a straight line.

If the function varies just as fast as the variable, we will have  $y = x$ . If the function varies twice as fast as the variable, we will have  $y = 2x$ , and if one half as fast,  $y = \frac{1}{2}x$ .

If  $y$  varies just as fast as  $x$ , or  $y = x$ , our graph will be as shown in Fig. 6. When we give various values to  $x$ , as 1, 2, 3, etc., it is obvious that the graph of  $y = x$  is the diagonal of the squares in common and that it is a straight line whose slope is constant and equal to 1.

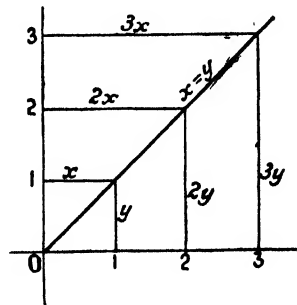

FIG. 6.

Likewise, for  $y = 2x$ , we have a series of rectangles for different values of  $x$  with coinciding diagonals as before. We still



have a straight line but with a different slope. The slope in this case will be 2 units of  $y$  to 1 of  $x$ , or  $\frac{y}{x} = 2$ .

In the same manner, we can have a function,  $y = mx$ , which shows that the ratio of  $y$  with respect to  $x$  is  $\frac{y}{x} = m$ .

Now  $m$  can be any quantity other than zero, as 6,  $\frac{1}{2}$ ,  $-3$ .

If  $m$  is greater than 1,  $y$  increases faster than  $x$ .

If  $m$  is negative,  $y$  decreases as  $x$  increases, and the graph slopes downward with respect to general positive direction of the  $X$ -axis, while for positive  $m$ s the graph slopes upward.

Since all these graphs have constant slopes, they are all straight lines. If the variation was not uniform, the slope would not be uniform and the function would not be of the first degree of  $x$ . Therefore, all functions of the first degree are straight lines.

127. Another way of considering this change in the relation of the function to the variable is, if  $h$  is the change in  $y$  for an increase in  $x$  equal to  $k$ , then the slope  $m$  is the ratio  $\frac{h}{k}$ . When  $y$  is increased by  $h$  and  $x$  is increased by  $k$ , we have, assuming that the given equation is  $y = mx$ ,

$$y + h = m(x + k) = mx + mk. \tag{2}$$

Subtracting (1) from (2),

$$\begin{array}{r} y + h = mx + mk \\ y = mx \\ \hline h = mk \end{array}$$

whence

$$m = \text{slope} = \frac{h}{k}.$$

128. The Function  $mx + b$ .—The graph of  $y = mx + b$  is as shown in Fig. 7.

When  $x = 0$ ,  $y = b$ , that is,  $y$  has an intercept equal to

$b$ , a constant. This amounts to saying that all values of the function  $y = mx + b$  are equal to the corresponding values of the function  $y = mx$  plus a constant,  $b$ . The slope of the graph is not changed, but the graph is raised in a vertical direction (assuming  $b$  to be positive) a distance equal to  $b$ .

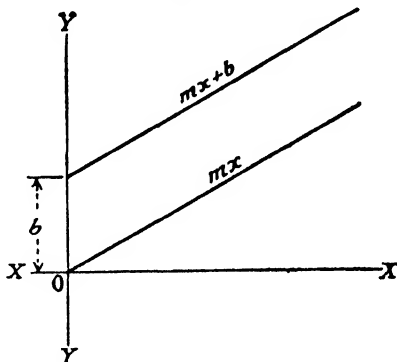

FIG. 7.

The function has an initial value  $b$  or a constant quantity, regardless of the value of  $x$ .

Equations and graphs are useful in solving problems. Some illustrative examples will be given in this chapter, and more systematic treatment will be given in later chapters.

**EXAMPLE.**—A railroad train starts 10 miles west of Chicago and travels west at the rate of 30 miles per hour. How far is the train from Chicago at the end of  $x$  hours?

In  $x$  hours, the train travels  $30x$  miles. If the distance from Chicago is denoted by  $y$ , we have  $y = 30x + 10$ .

$y$  has the initial value of 10.

30 is the ratio of the distance to the time, the rate of change of space, or the slope of the graph.

Another illustration is afforded by Hooke's law which states that a bar of steel under tension has a length equal to its original length  $b$ , plus the stretch which is proportional to the force  $x$  causing it, or  $y = mx + b$ .

The change ratio or slope of  $mx + b$  functions is constant for assuming two pairs of values, as  $(x_1, y_1)$  and  $(x_2, y_2)$ . Then

$$y_1 = mx_1 + b \quad \text{and} \quad y_2 = mx_2 + b,$$

whence

$$y_2 - y_1 = m(x_2 - x_1) \quad \text{and} \quad \frac{y_2 - y_1}{x_2 - x_1} = m.$$

*Conversely*, if the rate of change ratio of the function  $y$  of  $x$  is constant and equal to  $m$ , the function has the form,  $y = mx + b$ .

If we let  $\Delta x = x_2 - x_1$  and  $\Delta y = y_2 - y_1$ , the changes we make in  $x$  and  $y$ , we have

$$\frac{y_2 - y_1}{x_2 - x_1} = \frac{\Delta y}{\Delta x} = \frac{\text{Corresponding change in } y}{\text{For any change in } x}.$$

**129. Equations.**—An equation which is true for particular values of the variable appearing in it will remain true for those values after any one of the following operations has been performed:

Adding any quantity to both sides.

Subtracting any quantity from both sides.

Transposing any term from one side to the other (providing its sign is changed).

Multiplying or dividing both sides by any quantity which is not zero.

Changing the signs of all the terms.

Taking the logarithms of both sides (both sides being positive).

Taking the sin, cos, tan, etc., of both sides.

Bear in mind that when raising both sides to a power we introduce new roots not present in the original expression. Thus,  $x = -2$  has one root, but  $x^2 = 4$  has both  $+2$  and  $-2$  for roots.

An equation which does not contain a fraction with an unknown in the denominator is called an *integral equation*. Then

$$3x - y = 15, \frac{3x + 2y}{5} + \frac{5x + 3y}{3} = x + 1$$

are both integral equations because neither of them contains denominators with unknowns.

If both members of an integral equation are multiplied by the same integral expression containing an unknown, the resulting equation has all the roots of the given equation and also the roots of the equation formed by placing the multiplier equal to zero. The roots introduced are called *extraneous roots*.

If both members of an integral equation are divided by an integral factor common to both and containing an unknown, the resulting equation has all the roots of the given equation except those found from the equation formed by placing the factor removed equal to zero. The roots of the equation of the factor should be included with those of the resulting equation to determine all the roots of the given equation.

**130. Setting Up Problems in the Form of Equations.**—Denote the unknown quantity by  $x$ , and from the conditions given in the problem, *find the expressions which are equal, or form an equality, or equation*. One expression may equal another if an amount is added or subtracted, or the expression multiplied or divided by a number. By arranging these conditions to make the expressions *equal*, we form an equation.

Numerous laws of mathematics, mechanics, and physics often establish the foundation on which to build the equality, as  
 Length  $\times$  Width = Area of rectangle.

Rate of speed  $\times$  Time = Distance traveled.

Number of articles  $\times$  Price each = Total cost.

Number of persons  $\times$  Number of dollars received from each  
= Number of dollars received.

Principal  $\times$  Rate of per cent = Interest.

Square of the hypotenuse = Sum of the squares of the other two sides of a right-angled triangle.

A problem may state the equality direct. We then arrange the conditions of the problem to conform to this equality.

As an illustration, take the following problem:

In 15 years, A will be three times as old as he was 5 years ago. What is his present age?

We first look for an equality. If we multiply his age 5 years ago by 3, the product *equals* his age 15 years hence. This, then, is our equality or equation:

Age 15 years hence = 3 (age 5 years ago).

Let  $x$  = present age (which we are to determine).

Then  $x + 15$  = his age 15 years from now.

And  $x - 5$  = his age 5 years ago.

Forming the equation,

$$x + 15 = 3(x - 5) = 3x - 15.$$

$$2x = 30.$$

$$x = 15.$$

**131. To solve problems containing two unknowns, two statements or conditions are necessary.**

One unknown is usually denoted by  $x$  and the other by  $y$ , but it is not always necessary to use two symbols for the unknowns, for the second unknown can often be expressed in terms of the first.

Problems using two letters will be treated in the next chapter. The following problems illustrate cases where it is simpler to use only one letter.

**EXAMPLE.**—One number exceeds another by 8 and the sum of the two numbers is 14. Find the numbers.

The condition of equality is stated direct in the problem,

$$\text{Sum of numbers} = 14. \tag{1}$$

This is also a statement of a condition. The other statement is that one number exceeds the other by 8.

Let  $x$  = the smaller number.

Then  $x + 8$  = the larger number.

Forming the equality from (1),

$$x + (x + 8) = 14 \text{ (Art. 130).}$$

$$2x + 8 = 14.$$

$$2x = 6.$$

$$x = 3 = \text{the smaller number.}$$

$$x + 8 = 11 = \text{the other number.}$$

**132. If a problem contains three unknowns, three statements of conditions must be given in order to solve it.**

EXAMPLE.—A contractor spent \$1185 in buying additional dump cars, switches, and portable track sections, which cost \$90, \$35, and \$15, each, respectively. The number of switches exceeded the number of cars by 4 and the number of track sections was twice as many as the number of cars and switches together. How many did he buy of each?

We establish the equality from the statement,

Cost of cars + Cost of switches + Cost of track = \$1185, which is also one of the conditions. (1)

Let  $x$  = the number of cars.

Then  $x + 4$  = the number of switches (second condition).

And  $2[x + (x + 4)]$  = number of track sections (third condition).

Cost of cars =  $90x$ .

Cost of switches =  $35(x + 4)$ .

Cost of track sections =  $15(4x + 8)$ .

Forming an equation from (1),

$$90x + 35(x + 4) + 15(4x + 8) = 1185, \text{ from which (Art. 130)}$$

$$x = 5 = \text{the number of cars.}$$

$$x + 4 = 9 = \text{the number of switches.}$$

$$4x + 8 = 28 = \text{the number of track sections.}$$

**133. The tabular method** is a systematic arrangement of problems to assist in establishing the equality. Problems will best illustrate the scheme.

EXAMPLE.—The length of a rectangular field is twice its width. If the length is increased by 30 yards and the width decreased by 10 yards, the area would be 100 square yards less. Find the dimensions of the field.

$$\text{Length} \times \text{Width} = \text{Area.}$$

$$\text{First field} \quad 2x \quad x \quad 2x^2.$$

$$\text{Second field} \quad 2x + 30 \quad x - 10 \quad (2x + 30)(x - 10).$$

Condition of Equality.—If the area of the first field is decreased by 100 square yards, it equals the area of the second field.

Then  $2x^2 - 100 = (2x + 30)(x - 10)$  (Art. 130).  
 Solving,  $x = 20$ .  
 $2x = 40$ .

EXAMPLE.—A certain sum invested at 5 per cent yields the same amount as a sum \$200 larger at 4 per cent. What is the capital?

Principal	×	Rate	=	Interest.
$x$		.05		.05 $x$ dollars.
$x + 200$		.04		.04( $x + 200$ ).

Condition of Equality.—The interest in both cases is the same, whence

$$.05x = .04(x + 200) \text{ (Art. 130).}$$

Solving,  $x = \$800$ .

**134. Motion or Time and Distance Problems.**—In problems of this kind when velocity is constant, bear in mind that

$$\text{Time} \times \text{Velocity (rate of speed)} = \text{Distance.}$$

$$\text{Time} = \frac{\text{Distance}}{\text{Velocity}}.$$

$$\text{Velocity} = \frac{\text{Distance}}{\text{Time}}.$$

PROBLEM.—The speed of an express train is  $\frac{3}{5}$  of the speed of an accommodation train. If the accommodation train needs 4 hours more time than the express train to travel 180 miles, what is the rate of the express train?

	Time	×	Velocity	=	Distance.
Accommodation train	$\frac{180}{x}$		$x$		180.
Express train	$\frac{180}{\frac{9x}{5}}$		$\frac{9x}{5}$		180.

Condition of Equality.—If 4 hours is deducted from the time of the accommodation train, the remainder is *equal* to the time of the express train.

Then

$$\frac{180}{x} - 4 = \frac{180}{\frac{9x}{5}} \text{ (Art. 130.)}$$

$$x = 20 = \text{the velocity of the accommodation train.}$$

$$\frac{3}{5}x = 36 = \text{the velocity of the express train.}$$

PROBLEM.—A man starts from a certain place and rides his bicycle at the rate of 16 miles per hour; 45 minutes ( $\frac{3}{4}$  hour) later, an automobile starts from the same place and travels at the rate of 24 miles per hour. How long will it take the automobile to overtake him?

	Time	Velocity	Distance.
Bicycle	$\frac{x}{16}$	16	$x$ .
Automobile	$\frac{x}{24}$	24	$x$ .

Condition of Equality.—If  $\frac{3}{4}$  hour is deducted from the bicyclist's time, *it equals* the time of the motorist.

Therefore,

$$\frac{x}{16} - \frac{3}{4} = \frac{x}{24}. \quad (\text{Art. 130.})$$

$$x = 36.$$

$$\text{Motorist's time} = \frac{x}{24} = \frac{36}{24} = 1\frac{1}{2} \text{ hours.}$$

**135. Uniform Motion Graphs.**—If a man walks 3 miles each hour, we can illustrate the relation of time and distance graphically.

Lay off the scale for hours on the X-axis and miles on the Y-axis. In the first hour he travels 3 miles; therefore, locate a point  $x = 1, y = 3$ . A straight line through this point and the origin will determine the relation of time and distance.

The algebraic relation would be

$$s = 3t.$$

If this man was traveling to a town 12 miles from where he started, the graph shows that he would arrive at the town in 4 hours if he maintained the same rate of speed. Now if he had traveled at the rate of 4 miles per hour, he would have arrived at the town in 3 hours as represented by the graph *OC*. You will note that the second graph is much steeper than the first. Note also that the ratio of the distance to the time is the slope of the graph, and that graphs for uniform rates are straight lines.

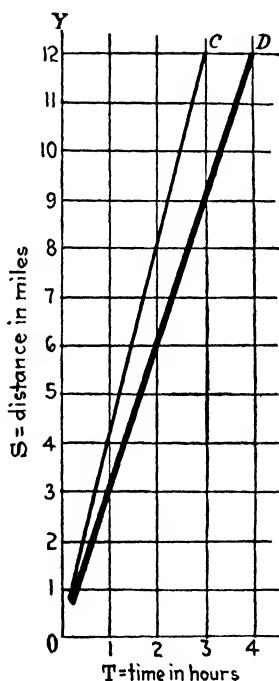

FIG. 8.

**PROBLEM.**—Jones drives a Ford car at the rate of 16 miles per hour for  $2\frac{1}{2}$  hours, stops  $1\frac{1}{2}$  hours for lunch, and then continues at his former

rate. Five hours after Jones departed, Smith starts in pursuit on a motorcycle, at the rate of 32 miles per hour. How far will they have traveled before Smith overtakes Jones?

ALGEBRAIC SOLUTION.

Let  $x$  = the distance in miles they travel. In  $2\frac{1}{2}$  hours at the rate of 16 miles per hour Jones rides 40 miles. Then

$x - 40$  = the distance Jones travels after lunch.

$\frac{x - 40}{16}$  = the time Jones traveled after lunch before he was overtaken.

$2\frac{1}{2} + 1\frac{1}{2} + \frac{x - 40}{16}$  = the total driving time of Jones.

$5 + \frac{x}{32}$  = Smith's driving time, plus 5 hours.

These times are equal; therefore,

$2\frac{1}{2} + 1\frac{1}{2} + \frac{x - 40}{16} = 5 + \frac{x}{32}$ , from which  $x = 112$  miles.

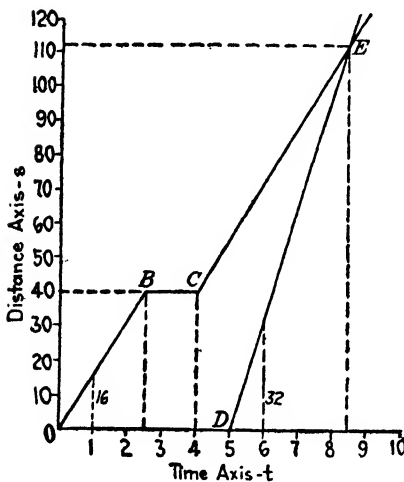

FIG. 9.

GRAPHICAL METHOD (Fig. 9).

$O$  is the starting point, since  $t = 0$  and  $s = 0$ .

Draw  $OB$  with slope  $\frac{1}{6}$  until it intersects the vertical line representing  $2\frac{1}{2}$  hours on the time axis. Now, for the next  $1\frac{1}{2}$  hours,  $s$  does not increase. This is denoted by  $BC$ , parallel to the time axis. The first man then continues at his former rate and this is indicated by  $CE$ , which has the same slope as  $OB$ .

The second man starts 5 hours later, that is,  $t = 5$ , but because he starts from the same place as the first man,  $s = 0$ . Through  $D$  draw  $DE$  with a slope of 32.

This is the graph which represents

the motion of the second man. The two graphs intersect at the point  $E$ , for which  $s = 112$ . Hence, the second man overtakes the first man after riding 112 miles.

Most solutions may be obtained accurately enough, graphically, because in nearly all cases such as the one just cited, speeds are approximations and are not absolutely accurate to measurement.



**136. More Uniform Motion Graphs** (see Fig. 10).

Let  $x$  start from a certain point  $O$  and travel 12 miles in 4 hours.  $OA$  is his graph. Now,  $y$  started an hour later, traveling the same distance, but arrived an hour earlier than  $x$ .  $BC$  is his graph.

How fast did  $y$  go and when and where did he pass  $x$ ?

The point of intersection of the two graphs answers this.  $EF$  shows the distance as 6 miles, and they passed 2 hours after  $x$  started ( $t = 2$ ).

Now consider  $z$  as having started at the same time as  $x$  but from the opposite end of the course and at the same speed as  $y$ .  $DE$  is his graph, which we make with negative slope of  $BC$ , since he traveled in the opposite direction.

The graph shows that  $z$  passed  $x$  after  $x$  had traveled 4 miles and after they had been traveling for  $1\frac{1}{2}$  hours.  $z$  passed  $y$  after  $y$  had gone 3 miles and after  $y$  had been traveling for  $\frac{1}{2}$  hour ( $t = 1\frac{1}{2}$ ).

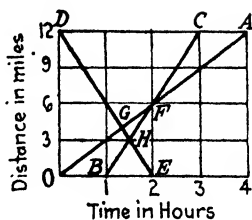

FIG. 10.

**137. Problems Relating to Per Cent.**

**PROBLEM 1.**—How much water must be added to 12 quarts of a 25 per cent solution of alcohol to reduce it to a 10 per cent solution?

Let  $x$  = the number of quarts to be added.

Then  $12 + x$  = the total number of quarts, and

10 per cent of  $(12 + x)$  = the number of quarts of alcohol, but

25 per cent of 12 or 3 = the number of quarts of alcohol.

$\therefore$  10 per cent of  $(12 + x)$  = 3, or  $1.2 + 10$  per cent of  $x = 3$ .

10 per cent of  $x = 1.8$ .

$x = 18$ .

**PROBLEM 2.**—A manufacturer desires to fill a 30-gallon vat with a 25 per cent solution of alcohol and water. He has on hand a 40 per cent solution which he wishes to mix with a 5 per cent solution.

How many gallons of each should be taken?

Let  $x$  = the number of gallons of 40 per cent solution.

Then  $30 - x$  = the number of gallons of 5 per cent solution.

From the condition of the problem,

$$0.40x + 0.05(30 - x) = 25 \text{ per cent of } 30.$$

$$0.40x + 0.15 - 0.05x = 7.5.$$

$$0.35x = 6.$$

$$x = 17\frac{1}{7} \text{ and } 30 - x = 12\frac{6}{7}.$$

Therefore, it requires  $17\frac{1}{7}$  gallons of the 40 per cent solution and  $12\frac{6}{7}$  gallons of the 5 per cent solution.

PROBLEM 3.—A man receives 6 per cent on some money invested and adds \$60 to the amount received, making \$300. How much did he invest?

Let  $x$  = the number of dollars invested.

Then  $0.06x$  = the number of dollars received.

And  $0.06x + 60 = 300.$

$$\therefore 0.06x = 240.$$

$$x = 4000.$$

NOTE.—Do not let  $x$  equal the money invested, but let it equal the *number of dollars* invested.

PROBLEM 4.—What per cent above cost must a man mark his goods so as to allow a discount of 20 per cent and still make a profit of 20 per cent?

The question is to find what per cent the marked price is to the cost of the goods, and then to find how much this is above cost.

Let  $c$  = the number of dollars of cost.

Then  $1.20c$  = the number of dollars of selling price.

Also, let  $m$  = the number of dollars of marked price.

Then  $.80m$  = the number of dollars of selling price.

$$\therefore .80m = 1.20c.$$

$m = 1.50c$ , which means that the goods must be marked 50 per cent above cost.

PROBLEM 5.—If 15 per cent of a number is 9165, what is the number?

Let  $x$  = the number.

Then  $0.15x = 9165.$

And  $x = 61,100.$

PROBLEM 6.—What number increased by  $66\frac{2}{3}$  per cent. of itself equals 275?

Let  $x$  = the number.

Then  $x + 66\frac{2}{3}$  per cent of  $x = 275$ , or  $1.66\frac{2}{3}x = 275.$

$$x = 165.$$

PROBLEM 7.—After deducting 10 per cent from the marked price of a table, the dealer sold it for \$13.50. What was the marked price?

Let  $x$  = the number of dollars of the marked price.

Then  $x - .10x = 13.50$ , or

$$.90x = 13.50.$$

$$x = 15.$$

### 138. Formulae in Interest.

Let  $p$  = the principal.

$r$  = the rate of interest per year.

$t$  = the time in years.

Interest = Principal  $\times$  Rate  $\times$  Time.  $i = prt$ .

$$\text{Principal} = \frac{\text{Interest}}{\text{Rate} \times \text{Time}}, \text{ or } p = \frac{i}{rt}$$

$$\text{Rate} = \frac{\text{Interest}}{\text{Principal} \times \text{Time}}, \text{ or } r = \frac{i}{pt}$$

$$\text{Time} = \frac{\text{Interest}}{\text{Principal} \times \text{Rate}}, \text{ or } t = \frac{i}{pr}$$

Since the interest on \$200 for 3 years at 6 per cent is \$36,

$$i = 200 \times 6 \text{ per cent} \times 3 = 36.$$

$$p = \frac{36}{3 \times .06} = 200.$$

$$r = \frac{36}{3 \times 200} = .06, \text{ or } 6 \text{ per cent.}$$

$$t = \frac{36}{.06 \times 200} = 3.$$

The sum of the interest and the principal is called the *amount*, or in symbols,

$$a = p + i.$$

$$a = p + prt.$$

$$a = p(1 + rt).$$

The principal, less the interest (if the interest is paid in advance), is called the *proceeds*.

$$\text{Proceeds} = P = p - i.$$

$$= p - prt.$$

$$= p(1 - rt).$$

Interest paid in advance as above is called discount.

**139. Six Per Cent Method of Finding Interest.**—Interest at 6 per cent for 60 days (2 months) is .01 and for 6 days is .001 of the principal. To find the interest for 600 days at 6 per cent, move the decimal point in the principal one place to the left; for 60 days, two places; and for 6 days, three places. After we find the interest at 6 per cent, we easily find the interest at other rates. Thus, for 5 per cent interest, take  $\frac{5}{6}$ , and for 7 per cent interest, take  $\frac{7}{6}$  of that at 6 per cent.

Interest is usually computed on the basis of a 360-day year.

**140. One-day Method in Interest.**—In large city banks, the discount rate varies from day to day. A short rule for finding the interest for 1 day at announced rate is given thus:

**EXAMPLE.**—Derive a 1-day rule for finding discount at  $4\frac{1}{2}$  per cent.

$$i = prt, r = 2\frac{1}{2}\%, t = 3\frac{1}{2}\text{d.}$$

$$i = p \cdot 2\frac{1}{2}\% \cdot 3\frac{1}{2}\text{d.} = p \cdot 8\frac{1}{4}\text{d.}$$

Hence, to find the interest for 1 day at  $4\frac{1}{2}$  per cent, point off three places and divide by 8.

**141. Exact interest** is based on a 365-day year, and has the ratio of  $\frac{7}{8}$  of the common interest based on 360 days. Exact interest can be found by adding  $\frac{1}{8}$  of the common interest to itself.

**Formulae for Discounts on Prices.**—If the list price is  $L$ , the net price  $N$ , and there is a single rate of discount  $r$ , then

$$N = L - rL = L(1 - r).$$

If there are two discounts,  $r_1$  and  $r_2$ , the second discount is taken as a percentage of the remainder after the first discount has been deducted, and then subtracted from that remainder. We then have

$$N = L(1 - r_1)(1 - r_2) \text{ and so on.}$$

Since  $L(1 - r_1)(1 - r_2) = L(1 - r_2)(1 - r_1)$ , it makes no difference which discount is taken first.

**142. Formulae in Commission.**—Brokerage or commission is charged on the basis of the entire volume of business transacted. It is usually a certain per cent of the *cost* when a purchase is made and of the *gross proceeds* when a sale is made.

The formulae based on sales, if  $P$  represents gross receipts,  $c$ , the commission, and  $r$ , the rate of commission, are

$$c = Pr, \quad r = \frac{c}{P}, \quad P = \frac{c}{r}.$$

If a broker or commission merchant does the buying and if  $C$  is the prime cost,  $c$ , the commission, and  $r$ , the rate of commission, then

$$c = Cr, \quad r = \frac{c}{C}, \quad C = \frac{c}{r}.$$

**143. Selling Prices.**—Salesmen's and agents' commissions are usually based on the selling price. This expense enters into

overhead or cost of doing business. It is more logical to establish the cost of the goods, the overhead charges, and the profit, each as a per cent of the selling price rather than of the cost.

By keeping careful records of a business, including all kinds of overhead charges, a business concern is able to standardize its expenses and determine what per cent of the selling price should be allowed to overhead charges to realize the expected profit and base it on the selling price and not on the gross costs.

**EXAMPLE 1.**—A dealer paid  $C$  dollars for an article, plus  $F$  dollars for freight and cartage. The cost of doing business has been found to be  $r$  per cent of the selling price, and the profit is to be  $p$  per cent of the selling price. We have

$$\text{Cost} = C + F \text{ dollars.}$$

Let  $x$  = selling price.

$$\text{Then } \frac{r}{100}x + \frac{p}{100}x = \text{Overhead} + \text{Profit.}$$

$$(\text{Selling price}) - (\text{Overhead} + \text{Profit}) = \text{Cost.}$$

Hence,

$$x - \left( \frac{r}{100}x + \frac{p}{100}x \right) = C + F.$$

$$x - \frac{r}{100}x - \frac{p}{100}x = C + F.$$

$$x = \frac{C + F}{1 - .01(r + p)}.$$

**EXAMPLE 2.**—A dealer has charged 10 cents per peck more for first-grade than for second-grade apples, and 15 cents per peck more for second grade than for third grade. After sorting a consignment of 10 bushels that cost him \$15, he finds that he has 5 bushels, 3 bushels, and 2 bushels, respectively, of the three grades. To maintain the above differentials and to make a profit of \$5 on the consignment, how much must he charge for a peck of each grade?

Statement 1. Price per peck of second grade = Price per peck of third grade + 15 cents.

Statement 2. Price per peck of first grade = Price per peck of second grade + 10 cents.

Statement 3. Total receipts = \$20.

Let  $x$  = the number of cents per peck of third grade.

Then  $x + 15$  = the number of cents per peck of second grade.

And  $x + 25$  = the number of cents per peck of first grade.

Hence,  $20(x + 25) + 12(x + 15) + 8x = 2000$ .

Solving,

$x = 33$  cents = price per peck of third grade.

$x + 15 = 48$  cents = price per peck of second grade.

$x + 25 = 58$  cents = price per peck of first grade.

**144. Graphical Illustration of Supply and Demand.**—The supply curve shows how the supply increases as the price increases.

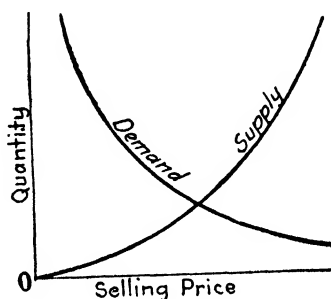

FIG. 11.

The demand curve shows the quantity that could be sold at each price.

There is a place where the supply is equal to the demand. This is the natural selling price.

## CHAPTER V

### LINEAR OR FIRST-DEGREE EQUATIONS. ANALYTICAL AND GRAPHICAL SOLUTIONS

**145. The General Equation,  $Ax + By + C = 0$ .**—Any linear relation between two variables,  $x$  and  $y$ , can be written in the form,

$$[2] \quad Ax + By + C = 0.$$

The equation,  $y = mx + b$ , can be derived from the general form provided  $B$  is different from zero. Thus,

$$\begin{aligned} By &= -Ax - C, \\ y &= -\frac{A}{B}x - \frac{C}{B}, \end{aligned}$$

in which

$-\frac{A}{B}$  represents the slope and  $-\frac{C}{B}$  gives the  $Y$ -intercept.

Every equation of the form,  $Ax + By + C = 0$ , when graphed in rectangular coordinates, represents a straight line.

If  $B = 0$ , the line is parallel to the  $Y$ -axis.

If  $A = 0$ , the line is parallel to the  $X$ -axis.

If  $C = 0$ , the line passes through the origin.

If the equation is multiplied by a constant  $k$  as

$$k(Ax + By + C) = 0,$$

the graph is identical with the graph of

$$Ax + By + C = 0.$$

#### **146. Problems of First Degree in $\frac{1}{x}$ (Work Problems).**

As an example consider the following:

**EXAMPLE.**—A can dig a ditch in 8 days. If B can do it in 10 days, how many days will it take them both, working together, to do it?

Let  $x$  = the number of days required.

Then

$$\frac{1}{x} = \text{the part of the work that both can do in 1 day.}$$

And

$$\frac{1}{8} = \text{the part of the work that A can do in 1 day.}$$

$$\frac{1}{10} = \text{the part of the work that B can do in 1 day.}$$

$$\therefore \frac{1}{x} = \frac{1}{8} + \frac{1}{10} = \frac{9}{40}$$

Inverting,  $x = \frac{40}{9} = 4\frac{4}{9}$  = the required number of days.

**147. Graphical Solution of Problem (Art. 146).**—Lay off the time in days on coordinate paper of, say, 20 divisions per inch, using a half-inch division to represent each day as abscissae and take any convenient ordinate on the Y-axis, as  $OH$ , to equal the total work.

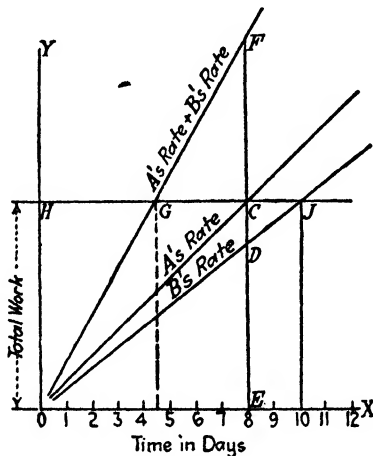

FIG. 12.

Since A can complete the work in 8 days, locate the point  $C$ , which has for its ordinate the completed work, and for its abscissa 8, the number of days required by him to complete it. The slope of the line  $OC$ , then, will be the rate at which A works. The ordinates for each day will represent the amount of work that he can do in the corresponding number of days.

Likewise, B can complete the work in 10 days, and  $OJ$  is the graph of his rate.



Now, the amount of work that they do, working together, in any given number of days may be obtained by a simple addition of ordinates. Thus, the amount that A does in 8 days is represented by  $CE$ , and the amount that B does in the same length of time is represented by  $DE$ . With dividers, lay off  $CF$  which is equal to  $DE$  so that  $EF = EC + ED$ . This means that  $EF$  is the measure of the work that they both will do in 8 days. Therefore,  $OF$  shows how the work is accomplished when both are working together.

Since our problem is to find how long will be required for both A and B working together to complete the work, we find that the abscissa which corresponds to the complete work  $OH$  is  $4\frac{2}{3}$  days.

In problems of this kind, it is only necessary to bear in mind that the rate is the slope of the line, which is the ratio of the ordinate to the abscissa. Usually this slope is given directly in the problem.

**148. PROBLEM.**—A and B can dig a ditch in 10 days; B and C can dig it in 6 days; and A and C can dig it in  $7\frac{1}{2}$  days. In what time can each man do the work?

Since A and B can dig  $\frac{1}{10}$  of the ditch in 1 day, B and C,  $\frac{1}{6}$  of it in 1 day, and A and C,  $\frac{1}{7\frac{1}{2}}$  of it in 1 day, then

$\frac{1}{10} + \frac{1}{6} + \frac{1}{7\frac{1}{2}}$  is twice the part that they can dig in 1 day, for each man would be working twice.

If  $x$  is the time it takes all of them to dig it,  $\frac{1}{x}$  is the part they will do in 1 day working together.

Then

$$\frac{1}{10} + \frac{1}{6} + \frac{2}{15} = \frac{12}{30} = \frac{2}{x} \quad \therefore \frac{1}{x} = \frac{1}{5}$$

That is, A + B + C will do  $\frac{1}{5}$  of the work in 1 day.

A + B will do  $\frac{1}{10}$  of it in 1 day. That is,

$$A + B + C = \frac{1}{5}$$

$$A + B = \frac{1}{10}$$

$C = \frac{1}{10} =$  part C does in 1 day, or it will take him 10 days

to complete the work. Similarly,

$$A + B + C = \frac{1}{5}$$

$$B + C = \frac{1}{6}$$

$$A = \frac{1}{5} - \frac{1}{6} = \frac{1}{30}$$

$$A + B + C = \frac{1}{5}$$

$$A + C = \frac{1}{7\frac{1}{2}}$$

$$B = \frac{1}{5} - \frac{1}{7\frac{1}{2}} = \frac{1}{15}$$

Thus, it will take A 30 days, and B 15 days to complete the work.

Add the ordinates of  $B + C$ ,  $A + C$ , and  $A + B$ , at any point as 8 days, and take one-half the sum for the ordinate of  $A + B + C$ . Draw  $ABC$  line through the point, then lay off  $AB$ ,  $CD$ , and  $EF$  equal to  $ON$ , and the points of abscissa equal 10, 15, and 30 days for  $C$ ,  $B$ , and  $A$ , respectively.

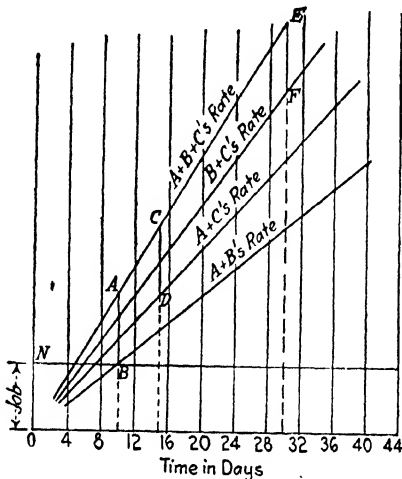

FIG. 13.

### 149. Graphical Solution of Additional Problems.

**EXAMPLE.**—A faucet which flows at the rate of 2 gallons per minute is discharging into an empty tank. After it has been running 10 minutes, a second faucet, which flows at the rate of 3 gallons per minute, is opened. When the second faucet has been running 5 minutes, a third faucet, which flows at the rate of 5 gallons per minute, is opened. Five minutes after the third faucet is started, an outlet is opened and empties the tank in 15 minutes, although the three faucets continue to run.

Draw a graph representing the amount of water in the tank at any instant. Find the average rate the tank is being emptied, as well as the rate of discharge per minute of the outlet.

The increase of the amount of water due to the faucets, as well as the decrease of the amount due to the outlet, is a constant rate, and their graphs are, therefore, linear.

The first faucet begins when  $t = 0$ , and the amount of water  $w$  is also 0. To supply water at the rate of 40 gallons in 20 minutes,  $OA$  is the graph of the first faucet running alone.

The second faucet begins when  $t = 10$  to supply water at the rate of 30 gallons in 10 minutes. If the second faucet operates alone, then  $BC$  is its graph.

After 10 minutes both faucets are open, and the sum of the two functions is then represented by the graph  $DE$  which is obtained by adding the ordinates of  $BC$  to the corresponding ordinate of  $OA$ , when the same abscissa is taken for both. When  $t = 15$ , the third faucet is opened at the rate of 50 gallons in 10 minutes. If it operates alone, then  $FG$  is its graph. When the ordinate of this graph is added to the sum of the other ordinates as done before, then the graph  $HJ$  is the sum graph.

When  $t = 20$ , the outlet is opened and at  $t = 35$ , the tank is empty. The straight line  $KL$  represents the rate the tank is being emptied, which has a negative slope of  $6\frac{1}{2}$  gallons per minute. The flow of the outlet is indicated by the slope of  $JM$  or  $81\frac{1}{2}$  gallons in 5 minutes, or  $16\frac{1}{2}$  gallon per minute. The complete graph is the broken line  $ODHKL$ , and the ordinates under the graph indicate the number of gallons in the tank for any time  $t$ .

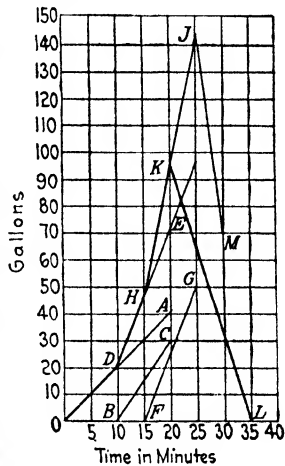

FIG. 14.

**150. Simultaneous Equations of the First Degree (Two Unknowns).**—One of the unknown numbers can be eliminated by addition or subtraction. If necessary, multiply the equation by some number that will make the coefficients of the quantity to be eliminated numerically equal.

**151. Elimination by Comparison.**—Reduce to the form.

$$\begin{aligned} x &= a - y. \\ x &= b + y. \end{aligned}$$

Then

$$a - y = b + y, \text{ or } 2y = a - b.$$

Since both  $a - y$  and  $b + y$  are equal to the same quantity,  $x$ , they are equal to each other.

**152. Elimination by Substitution.**

$$a_1x + b_1y = c_1. \tag{1}$$

$$a_2x + b_2y = c_2. \tag{2}$$

From (2),  $x = \frac{c_2 - b_2y}{a_2}$ .

Substituting in (1),

$$\frac{a_1(c_2 - b_2y)}{a_2} + b_1y = c_1.$$

Clearing of fractions,

$$a_1c_2 - a_1b_2y + a_2b_1y = a_2c_1, \text{ or}$$

$$y(a_2b_1 - a_1b_2) = a_2c_1 - a_1c_2.$$

$$y = \frac{a_2c_1 - a_1c_2}{a_2b_1 - a_1b_2}, \text{ which does not involve } x.$$

EXAMPLE.

$$3x + 2y = 27. \quad (1)$$

$$x - y = 4. \quad (2)$$

From (2),  $x = y + 4$  and  $3x = 3y + 12$ .

Substituting in (1),  $3y + 2y + 12 = 27$ , or

$$5y = 15.$$

$$\therefore y = 3.$$

Substituting in (2),  $x - 3 = 4$ , or  $x = 7$ .

The three methods of elimination just given, *i.e.*, addition or subtraction, comparison, and substitution, all produce the same resulting equation.

153. Equations of the form  $\frac{a}{x} + \frac{b}{y} = c$  may be readily solved

by regarding  $\frac{1}{x}$  and  $\frac{1}{y}$  as the unknown numbers.

EXAMPLE.

$$\frac{4}{x} - \frac{3}{y} = \frac{14}{5}. \quad (1)$$

$$\frac{4}{x} + \frac{10}{y} = \frac{50}{3}. \quad (2)$$

Subtracting (1) from (2), 
$$\frac{13}{y} = \frac{208}{15}.$$

$$\therefore \frac{1}{y} = \frac{16}{15}, \text{ or inverting, } y = \frac{15}{16}. \quad (3)$$

Substituting (3) in (1),

$$\frac{4}{x} - \frac{48}{15} = \frac{14}{5}.$$

$$\frac{1}{x} = \frac{3}{2}.$$

Inverting

$$x = \frac{2}{3}.$$

154. EXAMPLE.

$$\frac{1}{x-1} + \frac{1}{y+1} = 5.$$

$$\frac{2}{x-1} + \frac{3}{y+1} = 12.$$

Consider  $\frac{1}{x-1}$  and  $\frac{1}{y+1}$  as the unknowns. Then

$$2\left(\frac{1}{x-1}\right) + 2\left(\frac{1}{y+1}\right) = 10. \quad (1)$$

$$2\left(\frac{1}{x-1}\right) + 3\left(\frac{1}{y+1}\right) = 12. \quad (2)$$

Subtracting (1) from (2),

$$\frac{1}{y+1} = 2. \quad (3)$$

Inverting,

$$y + 1 = \frac{1}{2}, \quad y = -\frac{1}{2}.$$

Substituting (3) in (1),

$$\frac{1}{x-1} + 2 = 5.$$

$$\therefore \frac{1}{x-1} = 3.$$

Inverting,

$$x - 1 = \frac{1}{3}, \quad \text{or} \quad x = 1\frac{1}{3}.$$

155. Solve the equations,

$$ax + by = m. \quad (1)$$

$$cx + dy = n. \quad (2)$$

$$(1) \times d = adx + bdy = dm. \quad (3)$$

$$(2) \times b = bcx + bdy = bn. \quad (4)$$

$$(3) - (4) = (ad - bc)x = dm - bn.$$

$$\therefore x = \frac{dm - bn}{ad - bc}.$$

Likewise,

$$y = \frac{an - cm}{ad - bc}.$$

For a further discussion of this solution, see Art. 167.

**156. The Graphs of Simultaneous Equations of the First Degree in Two Variables are Straight Lines.**—A rapid method of solution is to draw the graphs on coordinate paper, and the

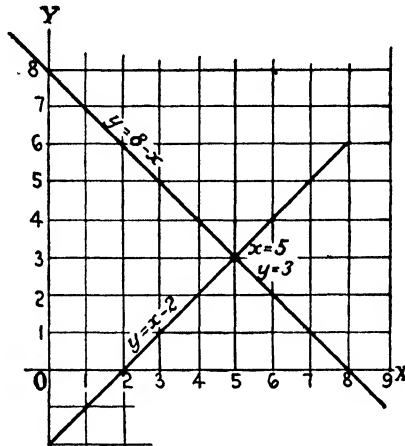

FIG. 15.

intersections determine the value of  $x$  and  $y$ , which satisfy both equations. Another method used is given under Determinants, Chap. XVIII (Art. 467).

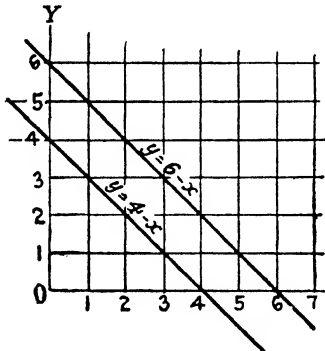

FIG. 16.

**157. Graphic representation of simultaneous linear equations like  $y = 6 - x$  and  $y = 4 - x$ .**

For every value of  $x$ , the values of  $y$  in the two equations differ by 2, and the graphs are 2 units apart vertically. Algebraically, we wish to find a set of values of  $x$  and  $y$  which satisfies both equations, but since the graphs do not intersect, the two equations have no common solution.

**158. Problems Leading to Equations in  $\frac{1}{x}$  and  $\frac{1}{y}$  (Work Problems).**

**EXAMPLE.**—A and B together can do a piece of work in 12 days. After A has worked alone for 5 days, B finishes the work in 26 days. In what time can each, working alone, do the work?

Let  $x$  = the number of days A requires to do the work.

$y$  = the number of days B requires.

Then

$\frac{1}{x} + \frac{1}{y}$  = that part of the work that they will be able to do in 1 day, working together.

Or

$\frac{1}{x} + \frac{1}{y} = \frac{1}{12}$  of the whole time.

$\frac{5}{x}$  = the part of work that A does in the 5 days.

$\frac{26}{y}$  = the part B does in 26 days.

Then

$\frac{5}{x} + \frac{26}{y} = 1$ , or the whole amount of work.

$\frac{1}{x} + \frac{1}{y} = \frac{1}{12}$ ,

from which  $x = 18$  and  $y = 36$  days.

**159. General Case.**—A and B can do a piece of work in  $a$  days, or if A works  $m$  days alone, B can finish the work by working  $n$  days. In how many days can each do the work?

Let  $x$  = the number of days A requires.

$y$  = the number of days B requires.

$$\therefore \frac{1}{x} + \frac{1}{y} = \frac{1}{a}. \quad (1)$$

Also, as before,

$$\frac{m}{x} + \frac{n}{y} = 1. \quad (2)$$

Multiplying (1) by  $n$

$$\frac{n}{x} + \frac{n}{y} = \frac{n}{a} \quad (3)$$

Subtracting (3) from (2),

$$\frac{m-n}{x} = 1 - \frac{n}{a} = \frac{a-n}{a}.$$

$$x = \frac{a(m-n)}{a-n}.$$

Multiplying (1) by  $m$ ,

$$\frac{m}{x} + \frac{m}{y} = \frac{m}{a}. \quad (4)$$

Subtracting (2) from (4),

$$\frac{m-n}{y} = \frac{m}{a} - 1 = \frac{m-a}{a}.$$

$$y = \frac{a(m-n)}{m-a}.$$

These values of  $x$  and  $y$  reduce the problem to formulae and the substitution of the proper values in these formulae gives quick results.

### 160. Another Form.

EXAMPLE.

$$\frac{xy}{x+y} = \frac{1}{5}.$$

$$\frac{yz}{y+z} = \frac{1}{6}.$$

$$\frac{xz}{z+x} = \frac{1}{7}.$$

If  $\frac{xy}{x+y} = \frac{1}{5}$ , then

$$\frac{x+y}{xy} = 5, \text{ whence}$$

$$\frac{1}{y} + \frac{1}{x} = 5, \text{ etc.}$$

In other words, separate the  $x$  and  $y$ , and proceed.

**161. Problem (Graphical Solution).**—A warship going at the rate of 10 miles per hour sights a ship 18 miles ahead of it going at the rate of 8 miles per hour in the same direction. How far can the ship go before it is overtaken?

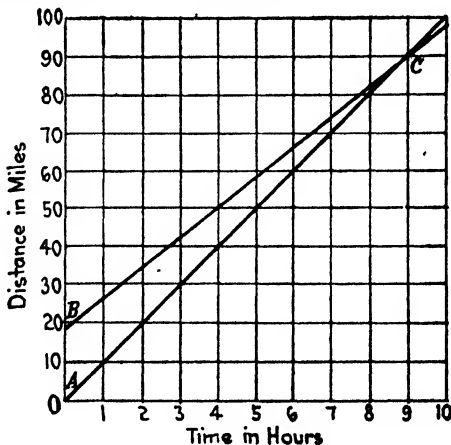

FIG. 17.

Draw  $AC$  with a slope representing a rate of 100 miles in 10 hours and  $BC$  with a slope representing a rate of 80 miles in 10 hours.



Make  $AB$  equal to 18 miles.

The point of intersection of the two graphs,  $C$ , gives the distance the warship goes as 90 miles and the time as 9 hours.

**162. Problem (Solution by Graph).**—Suppose that we have two towns that are 50 miles apart.  $A$  is to leave one of these towns at 6 o'clock and to arrive at the other at noon (12) after making four stops of a half hour each at 10, 20, 30, and 40 miles from the starting point.

$B$  leaves the other town at 7 o'clock, travels 20 miles an hour for 1 hour, then turns back, and retraces his path for an hour at the rate of 10 miles per hour. He then turns and advances again

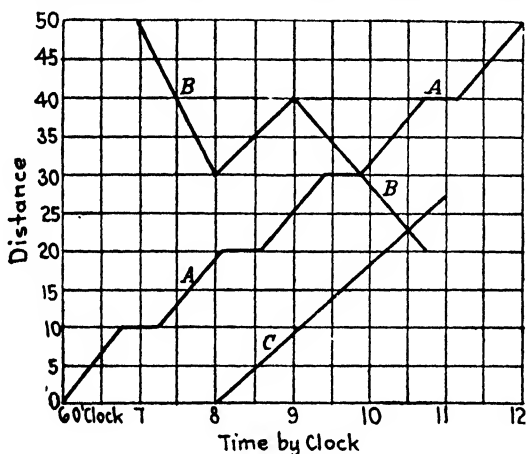

FIG. 18.

at such a rate as to meet  $A$  as he is starting from his third halt. Continuing at the same rate,  $B$  meets at half past ten (10:30) a third man,  $C$ , who left the first town 2 hours later than  $A$  and who has been going at a uniform rate. At what rate has  $C$  been traveling and where did  $B$  meet him?

Algebraically, this problem appears to be somewhat difficult of solution, and in fact the graphical solution is much the simpler and more direct method.

**SOLUTION.**—If  $A$  had traveled without stopping, he would have arrived at the town at 10 o'clock, since his halts aggregated, in all, 2 hours and he arrived at 12 o'clock. Therefore,

$$\frac{50}{4} = \frac{\text{Distance traveled}}{\text{Time consumed}} = \text{Rate or slope of graph.}$$

The complete graph of A's motion including the half-hour stops is as shown in Fig. 18. The graphs of the motions of B and C are easily made and it will be noted that B and C meet about 23 miles from where C started. The slope of C's graph is about  $9\frac{1}{2}$ , which indicates that C traveled at the rate of  $9\frac{1}{2}$  miles per hour. It will be understood, of course, that a much larger diagram than that shown is necessary in order to obtain accurate results.

NOTE.—Time of day may be plotted as abscissæ instead of the number of hours, since the two methods are in effect the same.

**163. Problem (Graphical Solution).**—Two men start at the same time to walk around an island. The first man goes at the rate of 5 miles per hour; the speed of the second man is such as will carry him around the island in  $3\frac{1}{3}$  hours, the distance being 10 miles. How long after starting will the first man pass the second and how long will it be before he will pass him the second time?

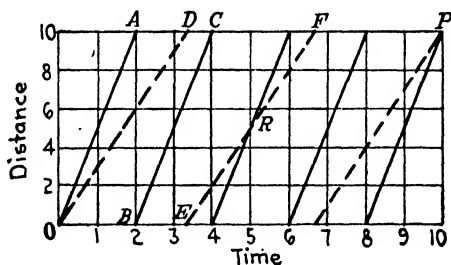

FIG. 19.

$OA, BC$ , etc. (Fig. 19) are the graphs representing the first man's trips around the island. When he starts on the second lap, represented by  $BC$ , the distance from the starting point is 0, and the graph starts with the same abscissa for  $B$  as for  $A$  since time goes on uniformly without any stop.

$OD, EF$ , etc. are the graphs representing the second man's progress.

The points of intersection,  $R$  and  $P$ , give the times and distances at which the two men pass. It will be seen that they first pass 5 hours after starting, at a distance of 5 miles from the starting point, and that they pass the second time at the starting point 10 hours after they started. This amounts to saying that

the first man traveled five times around the island while the second man was making three trips.

Note also that the first man had made two and one-half trips when he first passed the second man and that the second man had made one and one-half trips before he was overtaken.

It is evident from the foregoing examples that the graphical method is much more descriptive, shows much more to the eye than the analytical method, and is usually sufficiently accurate if a large scale is used.

**164. Clock Problems.**—Two bodies are traveling at different speeds under certain conditions. A common example is the motion of the hands of a clock.

**EXAMPLE.**—At what time between 5 and 6 o'clock are the hands of a clock together?

Beginning at 5 o'clock, let  $x$  represent the number of minute spaces passed over by the minute hand before the hands are together.

In the same time, the hour hand (which travels one-twelfth as fast) passes over one-twelfth as many minute spaces.

Since there are 25 minute spaces between them at 5 o'clock,

$$x = 25 + \frac{x}{12}, \text{ or } x - \frac{x}{12} = 25,$$

from which

$x = 27\frac{3}{4}$  = the number of minutes after 5 o'clock when the hands are together.

**165. Graphical Solution of Clock Problems.**—By representing graphically the motion of the hands of a clock, solutions for problems such as Art. 164 are easily obtained.

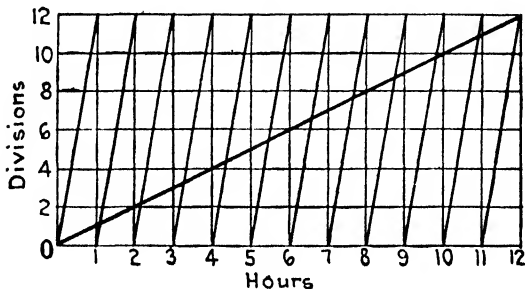

FIG. 20.

In Fig. 20 are shown the graphs representing the motions of the two hands of a clock during 12 hours. Minute spaces

traversed, or distance, is plotted as ordinates and time is plotted as abscissae. During the 12 hours, the hour hand has made 1 revolution which is represented in the graph by the long diagonal. In the same time, the minute hand has made 12 revolutions as shown by the 12 short diagonal lines. This graph and its explanation are analogous to those given in Art. 163 illustrative of the motion of two men around the island at different rates, and in this case also the intersections show the time and place where the two pass. Thus, it will be seen from the figure that if the two are together at noon, they will again be together a little after 1 and a little bit more after 2 o'clock, etc.

Let us take one hour from the diagram and enlarge it (Fig. 21).

The hands are at right angles at 3 o'clock. If we desire to know when they are again at right angles, we have only to observe in the figure the times at which there is a difference in vertical distance between the two graphs which will correspond to 15-minute divisions, since the hands are at right angles whenever they are 15-minute divisions apart. Thus, in the figure,  $AB$  is the graph of the minute hand for one hour, and  $CD$  is the graph of the hour hand. When there is a difference between their ordinates equal to the vertical distance representing 15 minutes, as at  $M$ , the hands are at right angles and the time is

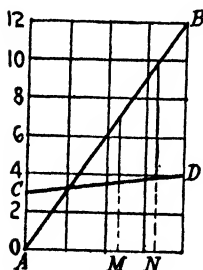

FIG. 21.

given by  $M$ . Similarly, if we desire to know when they are directly opposite to each other, we find the places in the graph for which the difference of ordinates is equal to the vertical distance representing 30 minutes or  $\frac{1}{2}$  hour. Such a place is shown at  $N$  and, as before,  $N$  indicates the time at which the hands assume such a position.

**166. Net Profit Problem.**—The net profit may be solved by using the graph of two simultaneous equations. One equation represents the total cost and the other, the total sales.

**EXAMPLE.**—The cost of the necessary machinery and its installation, before a certain toy could be manufactured, was \$300. Each toy produced cost 60 cents for material and labor and sold for \$1.25.

The cost equation is

$$C = 300 + 0.60n, \text{ where } n = \text{the number made.}$$

The sales equation is

$$S = n \times 1.25 = 1.25n.$$

When  $n = 800$ ,  $C = 780$  as shown at  $A$ , and  $S = 1000$ , as shown at  $B$ .

$$AB = \text{net profit} = 1000 - 780 = 220.$$

When  $n = 1000$ ,  $C = 900$  as shown at  $D$ , and  $S = 1250$ , as shown at  $E$ .

At  $F$  the sales just equal the cost when  $n = 461$ .

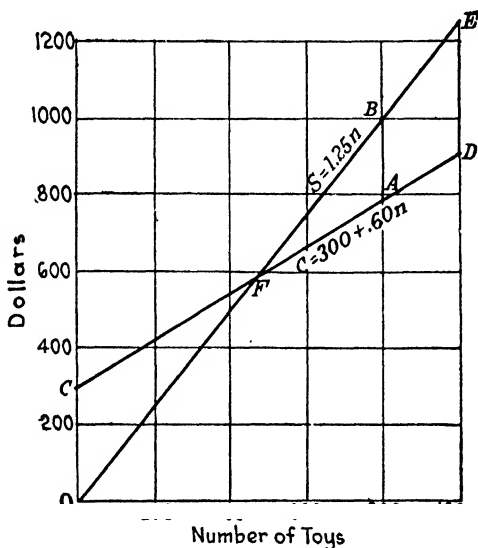

FIG. 22.

### 167. Simultaneous Equations. General Form.

Let

$$a_1x + b_1y = c_1 \text{ and}$$

$$a_2x + b_2y = c_2$$

be two simultaneous equations where none of the constants are 0.

Eliminating  $y$ , we have

$$(a_1b_2 - a_2b_1)x = c_1b_2 - c_2b_1.$$

Eliminating  $x$ , we have

$$(a_1b_2 - a_2b_1)y = c_1a_2 - c_2a_1.$$

If  $(a_1b_2 - a_2b_1)$  is any quantity other than 0, we have

$$x = \frac{c_1b_2 - c_2b_1}{a_1b_2 - a_2b_1} \quad \text{and} \quad y = \frac{a_1c_2 - a_2c_1}{a_1b_2 - a_2b_1}.$$

If

$$a_1b_2 - a_2b_1 = 0, \quad \text{or} \quad \frac{a_2}{a_1} = \frac{b_2}{b_1},$$

we cannot use the above solution.

If we let  $k = \frac{a_2}{a_1} = \frac{b_2}{b_1}$ , we have  $a_2 = ka_1$  and  $b_2 = kb_1$ .

The original equations, then, become

$$\left. \begin{aligned} a_1x + b_1y &= c_1 \\ ka_1x + kb_1y &= c_2 \end{aligned} \right\} \text{which represent the same line, or parallel lines.}$$

If  $c_2 = kc_1$ , the equations have an infinite number of solutions.

If  $c_2 \neq kc_1$ , the equations are not consistent and are not satisfied by any values of  $x$  and  $y$ .

**168. Equations in More than Two Unknowns.**—The methods used for two simultaneous equations each containing two unknowns may also be used for solving a system of three or more equations involving as many unknowns as there are independent equations. The following method of procedure is recommended: Continue to eliminate *the same unknown* in the given equations until there is obtained a group of one less than the original number of equations with one less unknown. Next eliminate a second unknown from the new group in the same manner. Continue these operations until only two simultaneous equations remain, which can readily be solved. The other unknowns can be found by substituting those found in some of the equations or by proceeding as at first but eliminating a different unknown this time.

EXAMPLE.

$$7x + 3y - 2z = 16. \quad (1)$$

$$5x - y + 5z = 31. \quad (2)$$

$$2x + 5y + 3z = 39. \quad (3)$$

Adding three times (2) to (1),

$$22x + 13z = 109. \quad (4)$$

Adding five times (2) to (3),

$$27x + 28z = 194. \quad (5)$$

Solving (4) and (5) by previous article, we have

$$x = 2, z = 5.$$

Substituting these values in (1), we have

$$y = 4.$$

It is readily seen that  $x = 2$ ,  $y = 4$ , and  $z = 5$  satisfy equations (1), (2), and (3).

## CHAPTER VI

### QUADRATICS OR SECOND-DEGREE EQUATIONS. EXPLICIT FUNCTIONS. ANALYTICAL AND GRAPHICAL SOLUTIONS

169. **The Quadratic Function  $x^2$ .**—The simplest quadratic equation is  $y = x^2$ . Its graph is a continuous curve, lying wholly above the  $X$ -axis, symmetrical with respect to the  $Y$ -axis, and passing through the origin and the points  $(1, 1)$  and  $(-1, 1)$ , and is known as the parabola (Fig. 23).

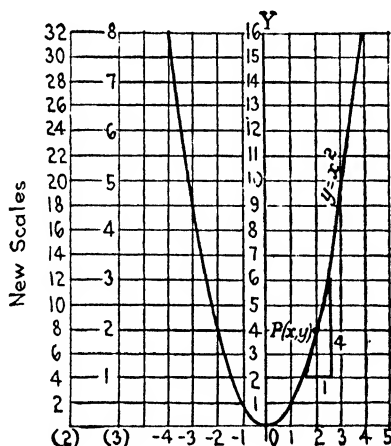

FIG. 23.

At any point  $P_1(x_1, y_1)$  on the curve, the straight line with slope  $2x_1$  passing through this point is tangent to the curve. The rate of change of the function with respect to the variable at any point  $(x_1, y_1)$  of the curve is equal to  $2x_1$ . Thus, when  $x_1 = 2$ , the slope of the tangent is 4.

These facts are here given without proof. They may be accepted and used as an aid in plotting. Their proof will be reserved for a later section (Art. 896).

For the plotting of graphs, it is advisable to use  $\frac{1}{2}$  inch for each unit, when the coordinate paper is ruled with 20 spaces per inch, or 1 centimeter per unit when the paper is metrically ruled.

170. The Graph of  $x^2$  with a Coefficient or  $ax^2$ .—For purposes of comparison, the graphs of

$$y = 2x^2, \quad (1)$$

$$y = x^2, \text{ and} \quad (2)$$

$$y = \frac{x^2}{2} \quad (3)$$

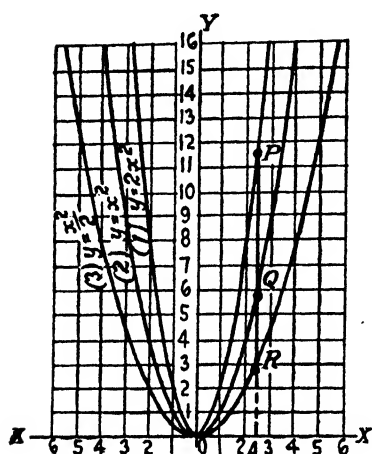

FIG. 24.

We can take the curve of  $x^2$  and, by using different scales of ordinates, obtain the graphs of  $2x^2$  and  $\frac{1}{2}x^2$  as in Fig. 23, where the same curve represents the locus of  $x^2$ ,  $2x^2$ , or  $\frac{1}{2}x^2$ , depending on which scale of ordinates is used.

Assuming that the graph of  $x^2$  is drawn using scale of ordinates (1), we can transform the curve to  $2x^2$  by renumbering the ordinates according to scale (2) or transform the graph to represent  $\frac{1}{2}x^2$  by using scale (3). We can also reverse the operation and change  $y = 2x^2$  to  $y = x^2$  by changing the ordinate scale.

171. The General Quadratic Function  $y = ax^2 + bx + c$ .—Let us start with the graph  $y = ax^2$  with origin at  $O$ , and consider what changes will occur in the equation if the origin is shifted

are all given in Fig. 24.

It will be noticed that for a given value of  $x$ , the ordinates of (1) are twice the corresponding ordinates of (2) and that the values of the corresponding ordinates of (3) are only half as great as the values of these ordinates of (2).

Likewise, for the two curves,

$$y = x^2, \text{ and}$$

$$y = ax^2,$$

the ordinates would have the ratio  $1:a$ ,  $a$  being any positive number.



to some other location as  $O_1$ , and a new equation of the curve written in terms of  $x_1$  and  $y_1$  referred to the new axes. From Fig. 25,  $x = x_1 + h$ , and  $y = y_1 + k$ .

If these values of  $x$  and  $y$  are substituted in  $y = ax^2$ , then

$$y_1 + k = a(x_1 + h)^2.$$

$$= ax_1^2 + 2ahx_1 + ah^2.$$

$$y_1 = a(x_1)^2 + 2ahx_1 + ah^2 - k.$$

This is in the form  $y_1 = a(x_1)^2 + bx_1 + c$ , or by dropping the subscripts,

$$[3] \quad y = ax^2 + bx + c,$$

which is known as the general form of the quadratic in one unknown. It is important to remember that this general form is the same locus as  $y = ax^2$  with the origin translated, and that the graph is always a parabola. It is also a form which every quadratic in one unknown can take.

**172. Transformation Coordinates.**—From the previous article (171), the graph of  $y = ax^2$  was transformed to the form  $y_1 = a(x_1)^2 + 2ahx_1 + ah^2 - k$  by substituting  $x_1 + h$  for  $x$ , and  $y_1 + k$  for  $y$ , which compared to the general form,

$$y = ax^2 + bx + c,$$

gives

$$a = a. \tag{1}$$

$$b = 2ah. \tag{2}$$

$$c = ah^2 - k. \tag{3}$$

From (2),

$$[4] \quad h = \frac{b}{2a},$$

and from (3),

$$k = ah^2 - c = \frac{b^2}{4a} - c,$$

or

$$[5] \quad k = \frac{b^2 - 4ac}{4a}.$$

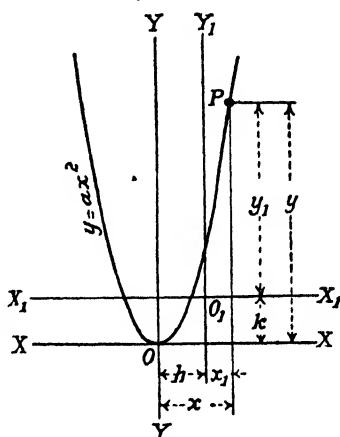

FIG. 25.

To change  $y = ax^2$  to the general form  $y = ax^2 + bx + c$ , we simply shift the origin to the point  $(h, k)$ , where

$$h = \frac{b}{2a} \quad \text{and} \quad k = \frac{b^2 - 4ac}{4a}.$$

In case we have the origin located and wish to find the vertex of the parabola, our directions will be reversed, and the formulae become

$$h = -\frac{b}{2a} \quad \text{and} \quad k = -\frac{b^2 - 4ac}{4a}.$$

173. We now come to the discussion of a very important method of graphically solving equations of the form,  $x^2 + bx + c = 0$  and  $ax^2 + bx + c = 0$ . Assume that we desire first the roots of  $x^2 + bx + c = 0$ . The graph of  $y = x^2 + bx + c$  will represent all of the corresponding real values of  $x$  and  $x^2 + bx + c$ ; and among them will be the values of  $x$  that make  $x^2 + bx + c$  equal to 0; that is, the roots of the equation  $x^2 + bx + c = 0$ .

We take our standard  $x^2$  graph, which we advise to keep in stock, and determine the origin by the values of  $h$  and  $k$

$$\left( h = \frac{b}{2a}, k = \frac{b^2 - 4ac}{4a} \right),$$

and then draw the  $X$ - and  $Y$ -axes. The intersections of the curve with the  $X$ -axis determine the roots.

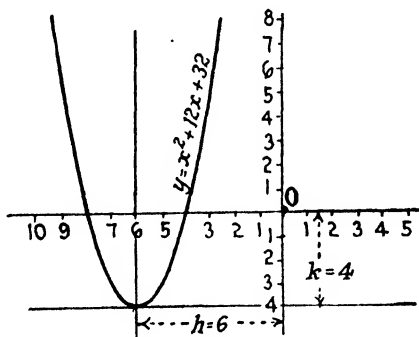

FIG. 26.

EXAMPLE.—Find the roots of  $x^2 + 12x + 32 = 0$ , graphically.

$$a = 1, b = 12, c = 32.$$

$$h = \frac{12}{1 \times 2} = 6, k = \frac{(12)^2 - 4 \times 32}{1 \times 4} = 4.$$

Therefore, locate  $O$  at  $(6, 4)$  and draw the  $X$ - and  $Y$ -axes. The  $X$ -axis intersects the graph at  $-4$  and  $-8$ , which are roots.

If our equation has the form,  $ax^2 + bx + c = 0$ , that is, if  $x$  has a coefficient  $a$ , we can use a graph obtained from the  $y = x^2$  graph by multiplying all the ordinates by  $a$ . A simpler method, however, is to use the  $y = x^2$  graph and change the scale of the ordinates.

The origin is located by finding  $h$  and  $k$  on the new scale, or  $h$  and  $\frac{k}{a}$  on the old scale.

EXAMPLE.—Draw the graph of  $y = 2x^2 - 16x + 24$ .

$$a = 2, b = -16, c = 24.$$

$$h = \frac{b}{2a} = \frac{-16}{2 \times 2} = -4, k =$$

$$\frac{b^2 - 4ac}{4a} = \frac{256 - 4 \times 2 \times 24}{8} = 8.$$

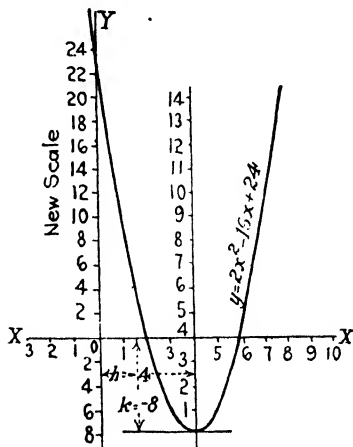

FIG. 27.

Take the  $y = x^2$  graph, and multiply the numbers in the vertical scale by 2, which gives the new vertical scale. Then take  $b = -4$  and  $k = 8$  on the new scale to locate the origin. The  $y = x^2$  graph is now converted into  $y = 2x^2 - 16x + 24$  graph.

**174.** To aid in determining easily the location of a graph and its coordinate axes, when its equation is given, the following examples are given as exercises:

EXAMPLE 1.— $x^2 - 8x + 14 = 0$ . Let  $y = x^2 - 8x + 14$ .

$$a = 1, b = -8, c = 14.$$

$$h = -4, k = \frac{(-8)^2 - 4 \times 14}{4} = \frac{64 - 56}{4} = 2.$$

Starting at the vertex, the origin is at the point  $(-4, 2)$ , four units in the negative direction (to the left) and two units upward. The roots of  $x^2 - 8x + 14 = 0$  are  $x = 2.6$  and  $x = 5.4$  approximately

EXAMPLE 2.— $x^2 - 8x + 16 = 0$ . Let  $y = x^2 - 8x + 16$ .

$$h = \frac{-8}{2} = -4, k = \frac{(-8)^2 - 4 \times 16}{4} = 0$$

The origin is at  $(-4, 0)$ .

The roots are  $x = 4$  and  $x = 4$ .

EXAMPLE 3.— $x^2 - 8x + 18 = 0$ .

$$h = -4, k = -2.$$

The origin is at  $(-4, -2)$  from vertex. This graph does not intersect the  $X$ -axis and the roots are, therefore, imaginary. The roots found by the analytical method (see Art. 183) are

$$x = 4 + 1.41\sqrt{-1} \text{ and } x = 4 - 1.41\sqrt{-1}.$$

EXAMPLE 4.— $x^2 + 8x + 14 = 0$ .

$$h = 4, k = 2.$$

The roots are  $x = -2.6$  and  $x = -5.4$ .

EXAMPLE 5.— $x^2 + 8x + 16 = 0$ .

$$h = 4, k = 0.$$

The roots are  $x = -4$  and  $x = -4$ .

EXAMPLE 6.— $x^2 + 8x + 18 = 0$ .

$$h = 4, k = -2.$$

The roots are imaginary but are equal to

$$x = -4 + 1.41\sqrt{-1} \text{ and } x = -4 - 1.41\sqrt{-1}.$$

175. In case the coefficient of the  $x^2$  term is negative, as

$$y = -3x^2 + 4x + 4,$$

$$a = -3, b = 4, c = 4.$$

$$h = \frac{4}{2(-3)} = -\frac{2}{3}, k = \frac{16 - 4(-3)(4)}{4(-3)} = -5\frac{1}{3}.$$

Since the  $x^2$  term is negative, the graph is inverted, but the  $h$  and  $k$  values are measured in the same manner as before from the vertex of the parabola, regardless of the inversion but using the new scale (see Fig. 28).

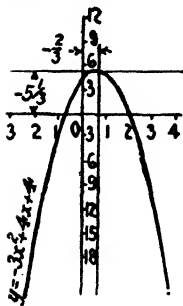

FIG. 28.

By using the graph of  $x^2$  as before and inverting it, we have the same method of solution as has already been discussed.

If  $b$  is negative, the origin will be to the left of the axis of the parabola.

If  $b$  is positive, the origin will be to the right of the axis of the parabola.

If  $a$  is positive, the parabola will have its vertex pointing downward.

The most important consideration of all is whether  $k$  is positive or negative. Now  $k$  is equal to  $\frac{b^2 - 4ac}{4a}$ , so that if  $a$  is positive,  $b^2 - 4ac$  determines the sign of  $k$ . From the discussion already given, it will be seen that if  $a$  is positive and  $k$  negative,

the  $X$ -axis will lie entirely below the curve and there will be no real roots since there will be no intersections of the curve and the  $X$ -axis. If  $a$  is negative and  $k$  positive, the  $X$ -axis will lie entirely above the curve and again there will be no real roots. Therefore, if  $a$  and  $k$  have like signs, the roots will be real and unequal; if  $k = 0$ , the roots will be real and equal; if  $a$  and  $k$  have unlike signs, there are no real roots.

Hence, it will be readily seen that:

If  $b^2 - 4ac$  is positive, the roots are real and unequal.

If  $b^2 - 4ac$  is equal to zero, the roots are real and equal.

If  $b^2 - 4ac$  is negative, the roots are imaginary.

If  $b^2 - 4ac$  is a perfect square, the roots will be rational; otherwise they will be irrational. The expression  $b^2 - 4ac$  is called the *discriminant* of the quadratic.

$$x^2 - 8x + 14 = 0. \tag{1}$$

$$x^2 - 8x + 16 = 0. \tag{2}$$

$$x^2 - 8x + 18 = 0. \tag{3}$$

Roots of (1) are approximately 2.6 and 5.4.

Roots of (2) are 4 and 4.

Roots of (3) are imaginary.

Since graph (2) has only one point in common with the  $X$ -axis, equation (2) appears to have only one root,  $x = 4$ . It will be observed, however, that if graph (1) which represented two real roots were moved upward two units, it would coincide with graph (2). During this process, the unequal roots of (1) would approach the value of  $x = 4$  in (2). Consequently, the real roots are regarded as two in number.

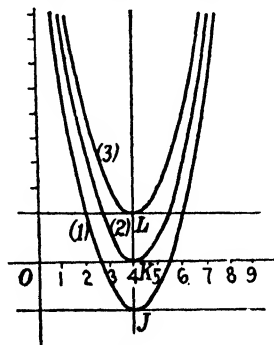

FIG. 29.

The movement of the graph of (1) upwards two units corresponds to completing the square in (1) by adding 2 to each member. Since the roots of the resulting equation,  $x^2 - 8x + 16 = 2$ , differ from those of (2) or from the mean value  $x = 4$  by  $\pm\sqrt{2}$  or  $\pm\sqrt{JK}$ , it is evident that the roots of (1) are represented by  $OK + \sqrt{JK} = 4 + \sqrt{2} = 5.414 +$  and  $OK - \sqrt{JK} = 4 - \sqrt{2} = 2.586 -$ .

Since graph (3) has no point on the  $X$ -axis, there are no real values of  $x$  for which  $x^2 - 8x + 18$  is equal to zero; that is, (3) has no real roots. Consequently, they are imaginary.

If graph (3) were moved downward two units, it would coincide with graph (2). If the square in (3) were completed by *subtracting* 2 from each member, the roots of the resulting equation,  $x^2 - 8x + 16 = -2$ , would differ from the mean value by  $+\sqrt{-2}$  or  $\pm\sqrt{LK}$ . Hence, it is evident that the roots of (3) are

$$OK + \sqrt{LK} = 4 + \sqrt{-2} \text{ and } OK - \sqrt{LK} = 4 - \sqrt{-2}.$$

The points,  $J$ ,  $K$ , and  $L$ , whose ordinates are the least algebraically that any points in the above graphs can have, are called *minimum points*.

When the coefficient of  $x^2$  is  $+1$ , it is evident from the preceding discussion that:

1. The roots of a quadratic in  $x$  are equal to the abscissa of the minimum point plus or minus the square root of the ordinate with its sign changed.

2. If the minimum point lies on the  $X$ -axis, the roots are real and equal.

3. If the minimum point lies below the  $X$ -axis, the roots are real and unequal.

4. If the minimum point lies above the  $X$ -axis, the roots are imaginary.

#### 176. Aids in Construction of Graphs of General Quadratic Function $y = ax^2 + bx + c$ .

Every function of the above form is continuous.

The slope of the tangent will be proved later to be  $2ax_1 + b$  at the point  $p_1(x_1, y_1)$  (Art. 913).

If  $a$  is positive, the curve has its vertex pointing downward, but if it is negative, the curve is inverted, thus:  $\frown$

The point on the curve where the slope is 0, or the vertex of the curve, is the point where

$$x_1 = -\frac{b}{2a} \quad (a \neq 0).$$

When  $x = -\frac{b}{2a}$ , the function  $y = ax^2 + bx + c$  has a minimum value if  $a > 0$  and a maximum value if  $a < 0$ .

The curve represented by the function is symmetrical with respect to the line,

$$x = -\frac{b}{2a}.$$

It is possible to determine by observation according to the above whether the curve is  $\cap$  or  $\cup$ .

If the former is the case, there is a maximum value at the vertex, and in the latter case the vertex represents a minimum since it is the lowest point on the curve.

To draw the graph of a parabola representing the locus of the equation,  $y = ax^2 + bx + c$ , we locate first the axis and the vertex and then a few points on the curve.

EXAMPLE.—Make a graph of

$$y = x^2 - 6x + 5.$$

The slope of the tangent  $m$  equals  $2ax_1 + b = 2x_1 - 6$ . Since the slope of the tangent at the vertex is equal to 0,  $2x_1 - 6 = 0$  and  $x_1 = 3$ . The value of  $y$  corresponding to this value of  $x$  is  $-4$ . These values of  $x$  and  $y$  locate the vertex, and since  $x^2$  is positive, the point is a minimum. Draw the axis which is the vertical line through the vertex. Draw the horizontal tangent at the vertex. Locate a few more points and draw the tangents to the curve at these points. Draw in the curve.

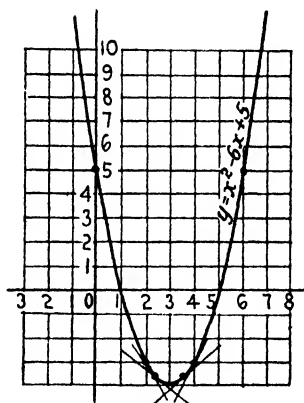

FIG. 30.

In substituting values of  $x$ , where the coefficient of  $x^2$  is  $+1$ , as is the case in this instance, it is convenient to take for the first value of  $x$  a number that is equal to half the coefficient of  $x$  with its sign changed. Next, values of  $x$  differing from this value of  $x$

by equal amounts may be taken. Thus, substituting  $x = 3$ , it is found that  $y = -4$ . Next, assign values to  $x$  differing from 3 by equal amounts, as  $2\frac{1}{2}$  and  $3\frac{1}{2}$ , 2 and 4, 1 and 5, 0 and 6. It will be found that  $y$  has the same value for  $x = 3\frac{1}{2}$  as for  $x = 2\frac{1}{2}$ , for  $x = 4$  the same value as for  $x = 2$ , etc.

It will be observed that when  $x = 3$ ,  $x^2 - 6x + 5 = -4$  and when  $x = 2$  and  $x = 4$ ,  $x^2 - 6x + 5 = -3$ . When  $x = 0$ ,

$x^2 - 6x + 5 = 5$ . Thus, it is seen that the ordinates change sign as the curve crosses the  $X$ -axis. When the ordinates are equal to zero, the values of  $x^2 - 6x + 5$  are equal to zero, and the abscissae denote the values of  $x$  which make  $y = 0$ . Hence,  $x = 1$  and  $x = 5$  make  $y = 0$ , or the roots of  $x^2 - 6x + 5 = 0$  are 1 and 5.

Note that half the coefficient of  $x$  with its sign changed, the number first substituted for  $x$ , is half the sum of the roots, or their mean value when the coefficient of  $x^2$  is  $+1$ .

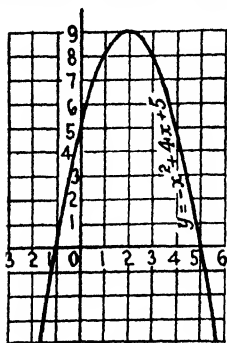

FIG. 31.

EXAMPLE.—Make a graph of

$$y = -x^2 + 4x + 5.$$

The slope of the tangent is  $-2x_1 + 4$ . Setting this equal to 0 and solving for  $x_1$  gives the abscissa of the vertex. The corresponding value of  $y$  is found by substituting the determined value of  $x$  in the equation of the locus. Here,  $x_1 = 2$  and  $y_1 = 9$ . Hence, the vertex, which is a maximum since  $a$  is less than 0, is at the point (2, 9).

The vertex must lie on the axis of the curve, and since the axis is readily found by means of the formula,  $x = -\frac{b}{2a}$ , we may use this formula directly to find the abscissa of the vertex. Since now the vertex is on the curve, its coordinates must satisfy the equation of the locus. Hence, by substituting the value of  $x_1$  for  $x$  in the equation and solving for  $y_1$ , we obtain the ordinate of the vertex.

**177. Maxima and Minima of Quadratic Functions.**—In Art. 176, it was stated that the function  $ax^2 + bx + c$  was a parabola with its vertex pointed downward, thus  $\cup$ , when the coefficient of  $x^2$  was positive. The point at the vertex, then, represents the minimum value of the function.

When the coefficient of  $x^2$  is negative, the curve is inverted and the vertex is pointed upward. It, therefore, denotes a maximum.

If we locate the axis of the parabola the abscissa of which is  $-\frac{b}{2a}$ , we will determine the maximum or minimum values of the function, for the vertex lies on the axis.



EXAMPLE.— $y = x^2 - 24x + 108$ .

The vertex will represent a minimum, since the coefficient of  $x^2$  is +1.

The abscissa of the vertex is  $-\frac{b}{2a}$ , or  $-\frac{-24}{2}$ , or +12.

∴ the function  $x^2 - 24x + 108$  will have a minimum value when  $x = 12$ .

EXAMPLE.—A rectangular piece of land is to be fenced in and a straight wall already built is available for one side of the rectangle. What should be the dimensions of the rectangle in order that 4 miles of fence will enclose the greatest area?

It is possible to construct an infinite number of rectangles having the same amount of fence, but of these there is only one which will contain the maximum area. The function with which we are here concerned is the area of the rectangle, a function of its two sides. Since we desire to have the function in terms of one variable, we must write one variable in terms of the other.

Let the sides of the rectangle be  $x$  and  $z$ . Since the given length of the fence is 4 miles, then

$$2x + z = 4$$

The area enclosed is  $y = xz$ , which, when  $4 - 2x$  is substituted for  $z$ , gives  $y = x(4 - 2x) = -2x^2 + 4x$ . The sign of the coefficient of  $x^2$  is negative and the function

$y$  will have a maximum value when  $x = -\frac{b}{2a} = -\frac{4}{-4} = 1$ , since  $a = -2$  and  $b = 4$ .

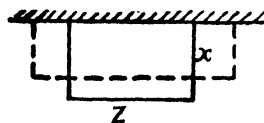

FIG. 32.

$$2x + z = 4. \quad 2 + z = 4, \text{ or } z = 2.$$

Dimensions of rectangle are 1 mile by 2 miles.

Area of rectangle is 2 square miles.

### 178. Graphical Solution of Art. 177.

$$y = -2x^2 + 4x \text{ (see Fig. 33).}$$

The graph has its vertex pointed upward, since  $a = -2$ .

Locate the vertex by means of the equations,

$$h = \frac{b}{2a} = \frac{4}{2(-2)} = -1 \text{ and}$$

$$k = \frac{16 - 0}{-8} = -2.$$

Locate the origin from the vertex of the  $y = x^2$  graph, 1 unit in the negative  $x$  direction (to the left) and 2 units in the negative  $y$  (downward) direction. The unit for  $y$  is different from those for  $x$  since  $a = -2$  and the numbers in the ordinate scale are multiplied by 2.

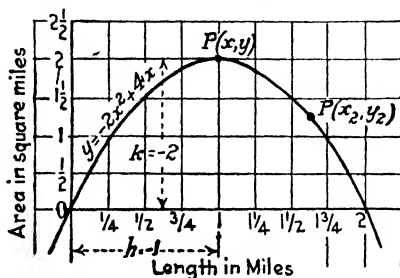

FIG. 33.

Any point on the graph represents an area enclosed by 4 miles of fence and the wall.  $P_1(x_1, y_1)$  and  $P_2(x_2, y_2)$  represent two such areas. It is readily seen, however, that the maximum area is represented by the ordinate at the vertex whose coordinates are  $(h, k)$ .

Bear in mind that the value of the function is shown by the ordinates and has no relation to the area under the curve. This area will be discussed later. We give the variable some value  $x_0$  and the length of the ordinate at this point represents the value of  $y$  ( $y_0$ ) for that particular value of  $x$ . From the graph we can readily see how the value of the function changes when we take different values for  $x$ .

**179. PROBLEM.**—Three streets intersect so as to enclose a triangular lot  $ABC$ . The frontage of the lot on  $BC$  is 180 feet and the point  $A$  is 90 feet back of  $BC$ . A rectangular building is to be constructed on this lot so as to face  $BC$ . What are the dimensions of the ground plan which will give the maximum size of floor area?

The area varies with the sides of the rectangle. It is, therefore, a function of the sides.

Let  $x$  and  $z$  be the length of the sides.

The area  $y = xz$ .

In order to express  $y$  in terms of one variable, we must express the second variable in terms of the first. The triangles  $ABC$  and  $AMN$  are similar. Hence,

$$\frac{MN}{BC} = \frac{LA}{DA}, \text{ or } \frac{x}{180} = \frac{90 - z}{90} \text{ from which } z = -\frac{1}{2}x + 90.$$

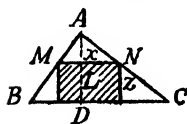

FIG. 34.

Substituting this value of  $z$  in  $y = xz$ , we obtain

$$y = -\frac{x^2}{2} + 90x + 0.$$

The function  $y = -\frac{1}{2}x^2 + 90x$  will have a maximum at

$$x = -\frac{b}{2a}, \text{ or } x = -\frac{90}{-2(\frac{1}{2})} = 90.$$

When  $x = 90$ ,  $z = 90 - \frac{1}{2}(90) = 45$ .

The maximum size of the building is, therefore, 90 by 45 and the area is 4050 square feet.

A solution of this problem may be obtained graphically in the same manner as in the previous problem.

**180.** The following method is a convenient one to use in constructing the graph of a parabola.

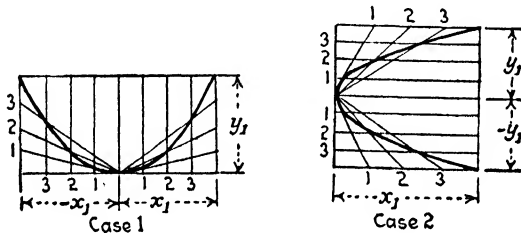

FIG. 35.

Assume some convenient value of  $x$ , say  $x_1$ , and solve for  $y_1$ , the corresponding value of  $y$ . Construct a rectangle as shown, using  $y_1$  as one side and  $2x_1$  as the other in Case 1. In Case 2 use  $x_1$  as one side and  $2y_1$  as the other side of the rectangle.

Divide  $x_1$  and  $y_1$  into equal divisions. The intersections of the parallel lines and the diagonals as shown are points on the graph. Draw the curve through these points (see Art. 755).

**181. Quadratic Equations. Analytical Methods.**—To solve quadratics, that is, to find the values of the unknown which satisfy the equation:

*First.* Reduce the equation to the general form [3],

$$ax^2 + bx + c = 0.$$

*Second.* If the factors are readily seen, solve by factoring.

*Third.* If the factors are difficult to find, solve by completing the square or by formula.

*Fourth.* Verify all results, rejecting roots that have been introduced in the process of reducing the equation to the general

form, and accounting for all roots that have been removed. The methods will be illustrated by examples.

EXAMPLE 1.—Find the roots of  $3x^2 = 10x - 3$ .

Reducing the equation to the form,  $ax^2 + bx + c = 0$ , gives

$$3x^2 - 10x + 3 = 0.$$

Factoring,

$$(x - 3)(3x - 1) = 0.$$

Therefore,

$$x - 3 = 0, \text{ or } 3x - 1 = 0.$$

And

$$x = 3 \text{ or } \frac{1}{3}.$$

EXAMPLE 2.—Solve  $x^2 + 6x = -5$  by completing the square.

Complete the square of the left member by adding 9 to both sides of the equation.

$$x^2 + 6x + 9 = -5 + 9.$$

$$(x + 3)^2 = 4.$$

Extracting the square root of both sides,

$$x + 3 = \pm 2.$$

$$x = -3 - 2 \text{ or } -3 + 2 = -5 \text{ or } -1.$$

EXAMPLE 3.—Find the roots of  $3x^2 + 10x = -3$ .

Multiplying by 3,

$$9x^2 + 30x = -9.$$

Completing the square,

$$9x^2 + 30x + 25 = -9 + 25 = 16.$$

To determine the amount to be added to complete the square, *make the coefficient of  $x^2$  a perfect square*. Then the number to be added to complete the trinomial square is obtained by dividing half the coefficient of  $x$  by the square root of the coefficient of

$x^2$  and squaring the quotient. Or  $\left(\frac{\frac{b}{2}}{\sqrt{a}}\right)^2 = \frac{\frac{b^2}{4}}{a} = \frac{b^2}{4a}$  after  $a$

is made a perfect square.

### 182. Quadratic Equations. Hindu Method of Solving.

To solve the general quadratic equation [3],

$$ax^2 + bx + c = 0. \tag{1}$$

Transposing  $c$ ,

$$ax^2 + bx = -c \tag{2}$$

Multiplying (2) by  $4a$ ,

$$4a^2x^2 + 4abx = -4ac.$$

Completing the square by adding  $b^2$  to both members,

$$4a^2x^2 + 4abx + b^2 = b^2 - 4ac.$$

Extracting the square root of both sides,

$$2ax + b = \pm \sqrt{b^2 - 4ac}.$$

Therefore,

$$x = \frac{-b \pm \sqrt{b^2 - 4ac}}{2a}$$

Hence, when a quadratic has the general form of (1), if the absolute term is transposed to the second member, as in (2), the square may be completed and fractions avoided, by multiplying by four times the coefficient of  $x^2$  and adding to each member the square of the coefficient of  $x$  in the given equation.

This is called the Hindu method of completing the square.

**183. Quadratic Equations. Solution by Formula.**—Every explicit quadratic equation in one unknown may be reduced to the form,  $ax^2 + bx + c = 0$  [3], in which  $a$  is positive, and  $b$  and  $c$  may be either positive or negative. The roots are

$$[6] \quad x_1 = \frac{-b + \sqrt{b^2 - 4ac}}{2a} \quad \text{and} \quad x_2 = \frac{-b - \sqrt{b^2 - 4ac}}{2a}$$

An examination of the above values of  $x$  will show that the nature of the roots, that is, whether they are real or imaginary, rational or irrational, may be determined by observing whether  $\sqrt{(b^2 - 4ac)}$  is real or imaginary, rational or irrational (see Art. 175).

Any quadratic, as  $ax^2 + bx + c = 0$ , may be reduced, by dividing through by the coefficient of  $x^2$ , to the form,

$$[7] \quad x^2 + px + q = 0,$$

whose roots are found by actual solution to be

$$[8] \quad x_1 = \frac{-p + \sqrt{p^2 - 4q}}{2} \quad \text{and} \quad x_2 = \frac{-p - \sqrt{p^2 - 4q}}{2}.$$

$$[9] \quad \text{Adding the roots, } x_1 + x_2 = \frac{-2p}{2} = -p.$$

$$[10] \quad \text{Multiplying the roots, } x_1x_2 = \frac{p^2 - (p^2 - 4q)}{4} = q.$$

Hence, the following rule:

The sum of the roots of a quadratic equation of the form,  $x^2 + px + q = 0$ , is equal to the coefficient of  $x$  with its sign changed, and the product of the roots is equal to the constant term.

**184.** Since we know that if two curves do not intersect, the values of  $x$  and  $y$  which satisfy both of them are imaginary, and  $b^2 - 4ac$  is negative when the roots are imaginary; therefore, to determine whether a first- and a second-degree curve intersect, solve simultaneously and eliminate  $y$ ; then note whether the discriminate  $b^2 - 4ac$  of the resulting equation is negative.

**EXAMPLE.**—Find whether the line,  $y = 2x + 12$ , and the circle,  $x^2 + y^2 = 25$ , intersect.

Eliminating  $y$ ,

$$\begin{aligned}x^2 + (2x + 12)^2 &= 25. \\5x^2 + 48x + 119 &= 0. \\b^2 - 4ac &= (48)^2 - 4(5)(119) = -76.\end{aligned}$$

The value of  $b^2 - 4ac$  is negative, and the curves do not, therefore, intersect.

### 185. Formation of Quadratic Equations.

If we let  $r_1$  and  $r_2$  be the roots given, we learned that the sum of the roots,  $r_1 + r_2 = -p$  [9] in the general form,  $x^2 + px + q = 0$  [7], and that their product,  $r_1r_2 = q$  [10]. Therefore, substituting  $-(r_1 + r_2)$  for  $p$  and  $r_1r_2$  for  $q$  in the general equation, we have

$$x^2 - (r_1 + r_2)x + r_1r_2 = 0.$$

Expanding,

$$x^2 - r_1x - r_2x + r_1r_2 = 0.$$

Factoring,

$$(x - r_1)(x - r_2) = 0.$$

Hence, to form a quadratic equation whose roots are given, subtract each root from  $x$ , and place the product of the terms so obtained equal to zero. Perform the multiplication.

**186. Factoring of Quadratic Expressions.**—Take the general expression of a quadratic,  $ax^2 + bx + c$  [3]. Then  $x^2 + \frac{b}{a}x + \frac{c}{a}$  vanishes when  $x - r_1$  is a factor and  $x = r_1$ .

Also,  $x = r_2$ , makes the expression equal to zero.

Consequently,  $a(x - r_1)(x - r_2)$  will be the factors, when  $r_1$  and  $r_2$  are the roots of the quadratic equation

$$x^2 + \frac{b}{a}x + \frac{c}{a} = 0.$$

EXAMPLE.—Find the factors of  $5x^2 - 7x - 22$ .

$$\begin{aligned} 5x^2 - 7x - 22 &= 5(x^2 - 1.4x - 4.4). \\ \text{Solving,} \quad x^2 - 1.4x - 4.4 &= 0. \\ x^2 - 1.4x + (0.7)^2 &= 4.89. \\ x - 0.7 &= \pm 2.211. \\ x &= 2.911 \text{ or } -1.511. \end{aligned}$$

Therefore, the factors are

$$5(x - 2.911)(x + 1.511)$$

Taking the most general form of an expression of the second degree,

$$ax^2 + bx + c = a\left(x^2 + \frac{b}{a}x + \frac{c}{a}\right) = a\left(x^2 + \frac{b}{a}x + \frac{b^2}{4a^2} + \frac{c}{a} - \frac{b^2}{4a^2}\right),$$

and the expression can be written as

$$a \left\{ \left(x + \frac{b}{2a}\right)^2 - \left(\frac{\sqrt{b^2 - 4ac}}{2a}\right)^2 \right\}$$

in terms of the difference of two squares.

Hence, the factors will be

$$[11] a \left(x + \frac{b}{2a} + \frac{\sqrt{b^2 - 4ac}}{2a}\right) \left(x + \frac{b}{2a} - \frac{\sqrt{b^2 - 4ac}}{2a}\right).$$

The nature of the factors depends upon the form taken by the expression,  $b^2 - 4ac$ , thus:

If  $b^2 - 4ac$  is a perfect square, the factors will be rational.

If  $b^2 - 4ac$  is positive and not a perfect square, the expression can be split up into factors, but the numerical part of the factors can only be given correct to as many significant figures as desired.

If  $b^2 - 4ac$  is negative, the factors can only be given in terms of complex numbers.

If  $b^2 - 4ac$  equals zero, the actual expression itself is a perfect square.

EXAMPLE.—Find the factors of  $8x^2 + 13x - 22$ .

$$\begin{aligned} 8(x^2 + 1.625x - 2.75) &= 8(x^2 + 1.625x + (.8125)^2 - 2.75 - (.8125)^2) \\ &= 8\{(x + 0.8125)^2 - 3.410\}. \\ &= 8\{(x + 0.8125)^2 - (1.847)^2\}. \\ &= 8(x + 2.659)(x - 1.035). \end{aligned}$$

The factors are 8,  $x + 2.659$ , and  $x - 1.035$ .

**187. Problem Involving a Quadratic Equation.**

**PROBLEM 1.**—A party hired a bobsled for \$12 and since three of the party failed to pay, each of the others had to pay 20 cents more. How many persons were in the party?

Let  $x$  = the number of persons.

Then  $x - 3$  = the number that paid.

$\frac{12}{x}$  = the number of dollars that each should have paid.

$\frac{12}{x - 3}$  = the number of dollars that each paid.

Therefore,

$$\frac{12}{x - 3} - \frac{1}{5} = \frac{12}{x}. \quad (\text{Note that one-fifth of a dollar} = 20 \text{ cents.})$$

Solving,  $x = 15$  or  $-12$ .

The second value of  $x$  is evidently inadmissible, for there could not have been a negative number of persons in the party.

**PROBLEM 2.**—A cistern can be filled by two pipes in 24 minutes. If it takes the smaller pipe 20 minutes longer to fill the cistern than it does the larger pipe, in what time can the cistern be filled by each pipe?

Let  $x$  = the number of minutes required by the larger pipe.

Then  $x + 20$  = the number required by the smaller pipe.

Since

$\frac{1}{x}$  = the part that the larger pipe fills in 1 minute,

and

$\frac{1}{24}$  = the part that both pipes fill in 1 minute,

also,

$\frac{1}{x + 20}$  = the part filled in 1 minute by the smaller pipe,

then,

$$\frac{1}{x} + \frac{1}{x + 20} = \frac{1}{24}.$$

Solving,  $x = 40$ , or  $-12$ .

**188. Equations in the Quadratic Form.**—An equation that contains but two powers of an unknown number or expression, the exponent of one power being twice that of the other, as

$$[12] \quad ax^{2n} + bx^n + c = 0.$$

in which  $n$  represents any number, is in the quadratic form.



EXAMPLE.—Find value of  $x$  in  $x^4 - 13x^2 + 36 = 0$ .

Factoring,

$$(x^2 - 4)(x^2 - 9) = 0.$$

Therefore,

$$x^2 - 4 = 0, \text{ or } x^2 - 9 = 0.$$

$$x = \pm 2, \text{ or } \pm 3.$$

EXAMPLE.—Find the value of  $x$  in  $x^4 - x^2 = 12$ .

Let  $x^2 = p$ . Then  $x^4 = p^2$  and

$$p^2 - p = 12.$$

Factoring,

$$(p + 3)(p - 4) = 0.$$

Therefore,

$$p = -3, \text{ or } 4.$$

Substituting,

$$x^2 = -3, \text{ or } 4,$$

whence  $x = 81$  (extraneous), or 256.

EXAMPLE.—Find the value of  $x$  in  $x^3 - 4x - 5x^2 = 0$ .

Let  $x^2 = p$ .

Then  $x^3 = p^2$  and  $x = p$ .

Then we have

$$p^3 - 4p^2 - 5p = 0.$$

Factoring,

$$p(p^2 - 4p - 5) = 0, \text{ whence } p = 0,$$

and  $p^2 - 4p - 5 = 0$ , or  $(p - 5)(p + 1) = 0$ ,

whence  $p = 5$ .

That is,

$$x^2 = 0, 5.$$

Therefore,  $x = 0$ , or 25.

EXAMPLE.—Find the value of  $x$  in

$$x^2 - 4x + \sqrt{x^2 - 4x - 21} = 63.$$

Subtracting 21 from both sides,

$$x^2 - 4x - 21 + \sqrt{x^2 - 4x - 21} = 42.$$

Put  $p^2 = x^2 - 4x - 21$  and the equation becomes

$$p^2 + p - 42 = 0.$$

Solving,

$$p = \sqrt{x^2 - 4x - 21} = 6, \text{ or } -7.$$

Solving,

$$x = 9.81, \text{ or } -5.81 \text{ (for } p = 6).$$

**189. EXAMPLE.**—Find the roots of  $x^4 + 4x^3 - 8x + 3 = 0$ .

Extract the square root as far as possible:

$$\begin{array}{r}
 x^4 + 4x^3 - 8x + 3 \mid x^2 + 2x - 2 \\
 \underline{x^4} \phantom{+ 4x^3} \phantom{- 8x} + 3 \\
 4x^3 \phantom{- 8x} + 3 \\
 \underline{4x^3 + 4x^2} \\
 2x^2 + 4x - 2 \mid \phantom{4x^3} - 4x^2 - 8x + 3 \\
 \underline{- 4x^2 - 8x + 4} \\
 - 1
 \end{array}$$

Since the first member lacks 1 of being a perfect square, the square may be completed by adding 1 to each member, which gives the following equation:

$$x^4 + 4x^3 - 8x + 4 = 1.$$

Extracting the square root,

$$x^2 + 2x - 2 = \pm 1.$$

Therefore,  $x^2 + 2x - 3 = 0$ , and  $x^2 + 2x - 1 = 0$ .

Solving,

$$x = 1, -3, -1 \pm \sqrt{2}.$$

**NOTE.**—This problem can also be solved by adding  $4x^2$ , as

$$x^4 + 4x^3 + 4x^2 - 4x^2 - 8x + 3 = 0,$$

or

$$(x^2 + 2x)^2 - 4(x^2 + 2x) + 3 = 0.$$

Then factor.

The factor theorem (Art. 186) can also be used to advantage.

**190. EXAMPLE 1.**—Find the roots of  $\frac{x^2}{x+1} + \frac{x+1}{x^2} = 4$ .

Since the first term is the reciprocal of the second, put  $p$  for the first term and  $\frac{1}{p}$  for the second term, thus,  $p + \frac{1}{p} = 4$ , or  $p^2 - 4p = -1$ .

Adding 4 to both sides,

$$p^2 - 4p + 4 = 3, \text{ or } (p - 2)^2 = 3.$$

$$p - 2 = \pm \sqrt{3}.$$

$$\therefore p = 2 \pm \sqrt{3} = 3.73, \text{ or } 0.27.$$

$$\frac{x^2}{x+1} = 3.73.$$

$$\frac{x^2}{x+1} = 0.27.$$

Solve these two quadratics for  $x$ .

**EXAMPLE 2.**—Solve  $x^2 = 9 + \sqrt{x^2 - 3}$ .

Take the radical as the unknown. By adding  $-3$  to both sides and transposing the radical to the left side, we have

$$x^2 - 3 + \sqrt{x^2 - 3} = 6, \text{ which may be easily reduced.}$$

The radical can also be replaced by  $z = x^2 - 3$ , which gives  $z^2 + z = 6$ .

EXAMPLE 3.—Solve  $x^4 + x^3 - 4x^2 + x + 1 = 0$ .

Dividing by  $x^2$ ,

$$x^2 + x - 4 + \frac{1}{x} + \frac{1}{x^2} = 0.$$

$$\left(x^2 + \frac{1}{x^2}\right) + \left(x + \frac{1}{x}\right) = 4.$$

Putting into the quadratic form by adding 2 to both sides,

$$\left(x^2 + 2 + \frac{1}{x^2}\right) + \left(x + \frac{1}{x}\right) = 6$$

Put  $u = x + \frac{1}{x}$ .

$$u^2 + u = 6.$$

$$u = 2 \text{ or } -3, \text{ or } x + \frac{1}{x} = 2 \text{ or } -3.$$

**191. Euclidean Graphical Method of Determining the Roots of Quadratic Equations.**—If, from any point without a circle, there be drawn two straight lines cutting it, the rectangles contained by the whole lines and the parts of them without the circle, equal each other (Euclid, III, 36).

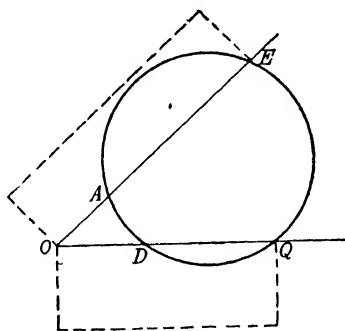

FIG. 36.

In Fig. 36,  $OA \times OE = OD \times OQ$ .

In applying the above theorem to obtain the roots of the quadratic equation,  $ax^2 + bx + c = 0$ , first put the equation in the form,

$$x^2 + \frac{b}{a}x = -\frac{c}{a},$$

or

$$x \left[ + \left( -\frac{b}{a} \right) - x \right] = \frac{c}{a} \times 1.$$

On intersecting axes, not necessarily at right angles,  $OX$  and  $OY$  (Fig. 37), lay off  $OA$  equal to unity and  $OE$  equal to  $\frac{c}{a}$ , both positive. Then, according to the theorem,  $OD$  equals  $x$  and

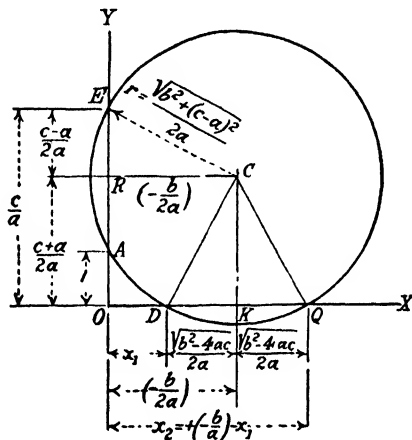

FIG. 37.

$OQ$  equals  $\left(-\frac{b}{a}\right) - x$ . These distances cannot be determined directly, but by finding the coordinates of the center of the circle,  $D$  and  $Q$  can be located as the points of intersection of the circle and the  $X$ -axis. Let  $DK = KQ$ ,

$$\text{Then } \frac{OQ - OD}{2} + OD = \frac{OQ + OD}{2} = OK,$$

or

$$\frac{\left(-\frac{b}{a}\right) - x + x}{2} = \left(-\frac{b}{2a}\right) = OK.$$

Then  $\left(-\frac{b}{2a}\right)$  is the  $x$  coordinate of the center of the circle. The  $y$  coordinate of the center of the circle is easily shown to be  $\frac{c+a}{2a}$ . If the coordinate axes are perpendicular, the radius of the circle can be found from the right triangle  $ECR$  to be

$r = \frac{\sqrt{b^2 + (c - a)^2}}{2a}$ , and from the right triangles  $DCK$  and  $KCQ$ ,

$$DK = KQ = \frac{\sqrt{b^2 - 4ac}}{2a}.$$

It is readily seen that the circle so drawn with the above relation to the coordinate axes fulfils all the conditions of the theorem. It must be understood that the circle is not a graph of the quadratic function but is used as a geometrical solution.

From Fig. 37,  $x_1$  and  $x_2$  can be determined.

$$\begin{aligned} x_1 &= OK - DK = \left(-\frac{b}{2a}\right) - \frac{\sqrt{b^2 - 4ac}}{2a} \\ &= \frac{-b - \sqrt{b^2 - 4ac}}{2a}. \end{aligned}$$

$$\begin{aligned} x_2 &= OK + KQ = \left(-\frac{b}{2a}\right) + \frac{\sqrt{b^2 - 4ac}}{2a} \\ &= \frac{-b + \sqrt{b^2 - 4ac}}{2a}. \end{aligned}$$

192. Five different cases will be discussed as follows:

Case 1.—If  $\left(-\frac{b}{2a}\right)$  and  $\frac{c+a}{2a}$  are both positive and the radius greater than the  $y$  coordinate  $\frac{c+a}{2a}$  of the center, the circle must cut the  $X$ -axis, and the  $x$  values will be real and positive as in Fig. 38a. Or

$$\begin{aligned} \frac{\sqrt{b^2 + (c - a)^2}}{2a} &> \frac{c + a}{2a} \\ \sqrt{b^2 + (c - a)^2} &> c + a. \end{aligned}$$

Squaring,

$$\begin{aligned} b^2 + (c - a)^2 &> (c + a)^2. \\ b^2 + c^2 - 2ac + a^2 &> c^2 + 2ac + a^2. \end{aligned}$$

Or

$$b^2 - 4ac > 0.$$

It is not necessary to compute the radius. The circle must pass through the point  $(0, 1)$  which is on the  $Y$ -axis in all cases, and after the center is located, simply set the divider with radius  $CA$  to draw the circle.

To solve  $x^2 - 6x + 5 = 0$ :

$$a = 1, \quad b = -6, \quad c = 5.$$

$$\left(-\frac{b}{2a}\right) = -\frac{-6}{2 \times 1} = 3.$$

$$\frac{c+a}{2a} = \frac{5+1}{2 \times 1} = 3.$$

In Fig. 38a locate the center of circle at (3, 3) and with  $CA$  as radius describe an arc cutting the X-axis at 1 and 5, which are the roots of  $x^2 - 6x + 5 = 0$ .

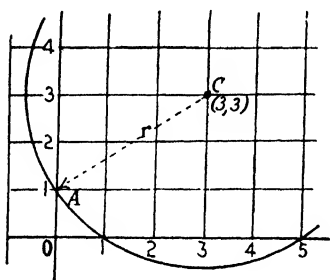

(a)

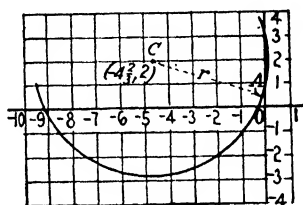

(b)

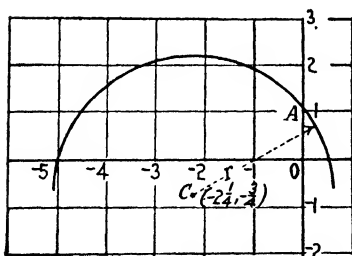

(c)

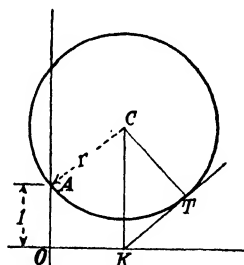

(d)

FIG. 38.

Case 2.—If  $\left(-\frac{b}{2a}\right)$  is *negative* and  $\frac{c+a}{2a}$  *positive*, draw  $\left(-\frac{b}{2a}\right)$  in the *negative* and  $\frac{c+a}{2a}$  in the *positive* direction.

To solve  $3x^2 + 28x + 9 = 0$ :

$$\left(-\frac{b}{2a}\right) = -\frac{+28}{6} = -4\frac{2}{3}$$

$$\frac{c+a}{2a} = \frac{9+3}{2 \times 3} = 2.$$

With center at  $(-4\frac{2}{3}, 2)$  and  $CA$  as radius (Fig. 38b) draw the arc cutting the  $X$ -axis at  $-\frac{1}{3}$  and  $-9$ , which are the roots of  $3x^2 + 28x + 9 = 0$ .

Case 3.—If  $(-\frac{b}{2a})$  and  $\frac{c+a}{2a}$  are both *negative*, draw both coordinates of center in negative direction as in Fig. 38c, which is a solution of  $2x^2 + 9x - 5 = 0$ . The roots are  $\frac{1}{2}$  and  $-5$ .

Case 4.—If  $(-\frac{b}{2a})$  is *positive* and  $\frac{c+a}{2a}$  *negative*, lay off  $(-\frac{b}{2a})$  in positive and  $\frac{c+a}{2a}$  in negative direction. One root will be positive and the other negative.

Case 5.—If the circle does not intersect the  $X$ -axis as shown in Fig. 38d, the roots are imaginary. The real part of root is given by  $OK$  and the imaginary part by  $KT$ , where  $T$  is the point of tangency of  $KT$  to the circle. The imaginary  $KT = \frac{\pm i\sqrt{4ac - b^2}}{2a}$ .

**193. Another Graphical Solution of Quadratic Equations (Short Cut).**—Let us assume two simultaneous equations of the forms,

$$y = x^2 \text{ and} \tag{1}$$

$$y = -\frac{bx}{a} - \frac{c}{a} \tag{2}$$

We know that the coordinates that satisfy both equations are at the points of intersection of the two curves represented by the equations (1) and (2).

Therefore, the abscissae of these points are values of  $x$  which satisfy both equations, and since both equations have the same value for  $y$  at these points, the right members of the equations are equal to each other, or

$$x^2 = -\frac{bx}{a} - \frac{c}{a} \tag{3}$$

or

$$ax^2 + bx + c = 0.$$

The latter expression is the general form of the quadratic equation [3].

We can, therefore, substitute the simultaneous equations (1) and (2) for equation (3) and we have an easy graphical solution for the general quadratic equation.

It is only necessary to keep on hand a few blueprints of an accurately plotted graph of  $y = x^2$ , and since the graph of (2) is a straight line, the intersections of the line and the curve give the roots of the equation.

The rule is to transfer all members of the equation but  $x^2$  to the right side of the equality and use the right member as the equation of the straight line.

If the line and the curve are tangent, the roots are equal.

If the line and the curve do not intersect, the roots are imaginary, since this indicates that there are no values of  $x$  which satisfy both equations.

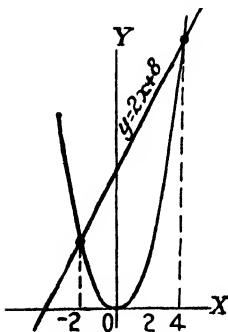

FIG. 39.

EXAMPLE.—Solve graphically the equation,  $x^2 - 2x - 8 = 0$ .

The values of  $x$  that satisfy the system,

$$y = 2x + 8$$

$$y = x^2,$$

are the same as those that satisfy the given equation.

Constructing the graph of  $y = x^2$  and the graph of  $y = 2x + 8$ , we have for the abscissae of the points of intersection  $x = -2$  and  $x = 4$  (Fig. 39).

Hence, the roots of the equation  $x^2 - 2x - 8$  are  $-2$  and  $4$ .

194. Another way of expressing the last method used for solving the quadratic is to break the equation into two simultaneous equations; thus, in the equation,  $3x^2 + 4x = 20$ , let  $y = x^2$ . If this value of  $x^2$  is substituted in the original equation, it becomes  $3y + 4x = 20$ , and the two simultaneous equations are  $3y + 4x = 20$  and  $y = x^2$ , which reduce to the same form as in Art. 193.

195. Quadratic Equations with Irrational Roots.—The roots of quadratics in engineering practice are usually irrational. The following method affords a means of finding the roots to a greater degree of accuracy than a graph will show, by combining an



algebraic with a graphical process: The graph of the quadratic expression is made from the graph of  $y = x^2$  as explained in previous articles, and the roots given a value as determined by the graph. A small correction  $h_1$  and  $h_2$  is then given to these roots which are substituted in the given quadratic expression, and the correction constants  $h_1$  and  $h_2$  found. The new equations give quadratics in  $h_1$  and  $h_2$ , but since the second-degree terms are very small, they can be disregarded, and simple linear functions of  $h_1$  and  $h_2$  make an easy means of finding these corrections. An example will illustrate the method.

EXAMPLE.—Find the roots of  $2x^2 - 9x + 6 = 0$ .

$$a = 2, b = -9, c = 6.$$

$$h = \frac{b}{2a} = \frac{-9}{2 \times 2} = -2\frac{1}{4}.$$

$$k = \frac{b^2 - 4ac}{4a} = \frac{81 - 4 \times 2 \times 6}{4 \times 2} = 4\frac{1}{8}.$$

The graph of  $y = 2x^2 - 9x + 6$  is shown in Fig. 40 taken from  $y = x^2$  with origin at  $(-2\frac{1}{4}, 4\frac{1}{8})$ . An inspection of the graph shows the roots to be approximately  $x = .8$  and  $x = 3.7$ .

Assume a correction  $h_1$  to the first given root; then

$$x = .8 + h_1$$

Substitute  $.8 + h_1$  for  $x$  in the given equation,  $2x^2 - 9x + 6 = 0$ , but disregard the second degree term  $h_1^2$ , since it is very small.

Then

$$1.28 + 3.2h_1 - 7.2 - 9h_1 + 6 = 0.$$

$$5.8h_1 = .08.$$

$$h_1 = .014.$$

Then  $x = .8 + .014 = .814$ , the corrected root to three decimal places.

The second root,  $x = 3.7$ , is corrected in the same manner by making  $x = 3.7 + h_2$ .

The substitution of  $3.7 + h_2$  for  $x$  in the given equation as before gives

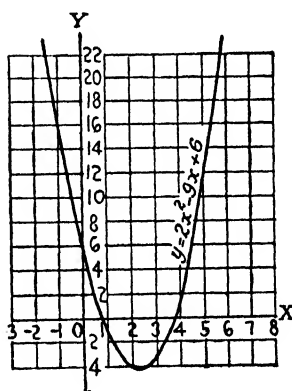

FIG. 40.

$$27.38 + 14.8h_2 - 33.3 - 9h + 6 = 0.$$

$$5.8h_2 = -.08.$$

$$h_2 = -.013.$$

Then

$x = 3.7 - .013 = 3.687$ , the corrected value of the root.

The negative sign indicates that the assumed value 3.7 of the root taken from the graph was too large and must be reduced by .013.

This method is sufficiently accurate for most engineering purposes, but of course a second correction can be taken by using the corrected values,  $x = .814$  and  $x = 3.687$ , and repeating the method as before, which will correct the roots to five or six decimal places. This method can also be used for simultaneous quadratic equations or cubic equations or any problem using a graphical solution.

## CHAPTER VII

### IMPLICIT QUADRATIC FUNCTIONS WITH GRAPHS. SIMULTANEOUS QUADRATIC EQUATIONS.

**196. The Implicit Functions.**—The general form of the quadratic equation in  $x$  and  $y$  is

$$[13] \quad Ax^2 + Bxy + Cy^2 + Dx + Ey + F = 0.$$

Such an equation *implies* that  $y$  is equal to some function of  $x$ , although we may not know what function. We say, in such a case, that  $y$  is an *implicit* (or implied) *function* of  $x$ .

The present object is to obtain a general idea of curves of this form and to find the relations existing between the different members of the equation and their coefficients.

The reasons for the relations, as well as their proofs, will be discussed later in the section devoted to analytical geometry. The reason for their introduction at this time is to assist in establishing the connections between the algebraic and the graphical methods of solution.

In general, the presence of the first-degree terms indicates that the coordinate axes of the curve which represents the second degree and constant terms have been translated.  $Dx$  indicates that the curve has been translated in the  $x$  direction and  $Ey$  indicates that the curve has been translated in the  $y$  direction. If both members,  $Dx$  and  $Ey$ , of the general equation [13] are present, the curve has been translated in both the  $x$  and the  $y$  directions. There are exceptions to this rule as in Arts. 169 and 197.

The  $Bxy$  term indicates that the axis of the curve has been rotated through an angle with the coordinate axes.

The remaining terms of the equation determine, by their different combinations, the shape or nature of the curve or graph.

The peculiar property of the implicit function given by the equation,  $Ax^2 + Bxy + Cy^2 + Dx + Ey + F = 0$ , is that  $y$  is usually a two-valued function of  $x$ . For a particular value of  $x$  there are two values of  $y$  unless  $C = 0$ .

Let us consider some of the simpler cases of the general equation, such as

$$[14] \quad Ax^2 + Ey = 0.$$

$$[15] \quad Cy^2 + Dx = 0.$$

$$[16] \quad Ax^2 + Ey + F = 0.$$

$$[17] \quad Cy^2 + Dx + F = 0.$$

$$[18] \quad Ax^2 + Cy^2 + F = 0.$$

In equation [14], by transposing  $Ey$  and dividing through by  $E$ , we have

$$y = -\frac{A}{E}x^2,$$

which is of the form,  $y = ax^2$ , with

$$a = -\frac{A}{E}.$$

This case has already been discussed in Art. 170. It will be remembered that this represents a parabola having the  $Y$ -axis for its axis of symmetry, and having its vertex pointing downward if  $a$  is positive, or upward if  $a$  is negative. It follows from the above that if  $A$  and  $E$  have like signs, the parabola will have its vertex pointing upward since  $a$  will be negative, and if  $A$  and  $E$  have unlike signs, the vertex of the parabola will be pointing downward since  $a$  will then be positive.

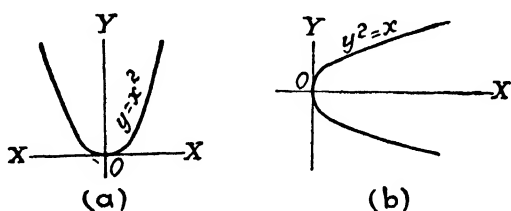

FIG. 41.

In equation [15], we have a condition analogous to the one just discussed excepting that the  $x$  and  $y$  coordinates have been interchanged, so that the  $X$ -axis is the axis of symmetry of the parabola. This equation is of the form,  $x = ay^2$ , for by transposing  $Cy^2$  and dividing by  $D$  we have

$$x = -\frac{C}{D}y^2. \quad \therefore a = -\frac{C}{D}.$$

Reasoning similar to that used in the case of  $y = ax^2$  shows that when  $C$  and  $D$  have like signs, the vertex of the parabola will be pointed toward the positive end of the  $X$ -axis, and when  $C$  and  $D$  have unlike signs, the vertex will be pointed toward the negative end of the  $X$ -axis.

[16]  $Ax^2 + Ey + F = 0$  is the form taken by the general equation when  $B$ ,  $C$ , and  $D$  are zero, and

[17]  $Cy^2 + Dx + F = 0$  is the form taken by the general equation when  $A$ ,  $B$ , and  $E$  are each zero.

The equations [16] and [17] can be readily changed to the explicit forms,  $y = ax^2$  and  $x = ay^2$ , and solved according to the method of Art. 170.

**197. Form  $Ax^2 + Cy^2 + F = 0$ .**—If  $B$ ,  $D$ , and  $E$  are each zero, the general form reduces to

$$[18] \quad Ax^2 + Cy^2 + F = 0.$$

If  $A = C \neq 0$ , and  $\frac{F}{A}$  is negative, we can reduce [18] to

$$[19] \quad x^2 + y^2 = a^2.$$

Since we know the relation of the sides of a right-angled triangle to be  $x^2 + y^2 = a^2$  (Fig. 42),  $x^2 + y^2$  is the square of the distance of  $P$  from the origin, or  $x^2 + y^2 = a^2$  states that  $P(x, y)$  is at a distance of  $a$  units from the origin at all times, and the graph is, therefore, a circle of radius  $a$ , whose center is at the origin.

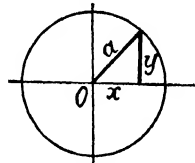

FIG. 42.

**198.** If  $A = C \neq 0$ , the equation,  $Ax^2 + Cy^2 + F = 0$ , may be written in the form,

$$[20] \quad x^2 + y^2 = -\frac{F}{A}.$$

If  $-\frac{F}{A}$  is positive, the graph is a circle; if negative, there is no graph. If  $F = 0$ , the circle reduces to a point at the origin.

The graph of the circle may be used in the graphical solution of simultaneous equations, thus:

**EXAMPLE.**—Find the values of  $x$  which satisfy the equations,

$$x^2 + y^2 = 25$$

and

$$x - 7y + 25 = 0.$$

The solutions are obtained by drawing the graphs of the circle represented by  $x^2 + y^2 = 25$  and the straight line represented by  $x - 7y + 25 = 0$ . The intersections of the graphs are the only points which satisfy both equations, and the abscissae of these points denote the values of  $x$  for which both equations are true.

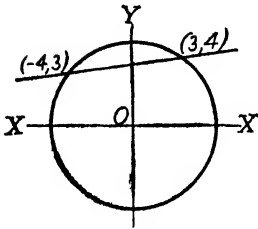

FIG. 43.

199. The term  $-\frac{F}{A}$  must be positive

when the graph is a circle, and  $\sqrt{-\frac{F}{A}}$  gives the radius of the circle. Any value of  $x$  greater numerically makes the value of  $y$  imaginary, for, by transposing,  $y^2 = -\frac{F}{A} - x^2$ . Since for all real values of  $x$  and  $y$ ,  $x^2$  and  $y^2$  will be positive, so then if  $x^2$  is greater numerically than  $\frac{F}{A}$ ,  $y^2$  will be negative, which cannot be if  $y$  is a real number. This may be seen from the graph, since any value of  $x$  which makes  $x^2$  greater than  $-\frac{F}{A}$  will be outside the range of the circle. Hence, all values of  $x$  should be taken which are numerically less than  $\sqrt{-\frac{F}{A}}$ .

200. If  $A$  and  $C$  are not equal, then  $Ax^2 + Cy^2 + F = 0$  takes the form,

$$[21] \quad x^2 + \frac{C}{A}y^2 = -\frac{F}{A},$$

where

$$-\frac{F}{A} \text{ is positive, or}$$

$$[22] \quad x^2 + n^2y^2 = a^2,$$

where

$$[23] \quad n = \sqrt{\frac{C}{A}}$$

and

$$[24] \quad a = \sqrt{-\frac{F}{A}}.$$

Then, equation  $x^2 + n^2y^2 = a^2$ , representing the ellipse, can be put in the form,

$$y = \pm \frac{1}{n} \sqrt{a^2 - x^2}.$$

Likewise, the equation,  $x^2 + y^2 = a^2$ , which represents a circle, can take the form,

$$y = \pm \sqrt{a^2 - x^2}.$$

A comparison of the  $y$  values, or ordinates, shows that: The ordinates of the ellipse: The ordinates of the circle

$$= \frac{1}{n} : 1 = \frac{1}{\sqrt{C}} : 1 = \sqrt{\frac{A}{C}} : 1.$$

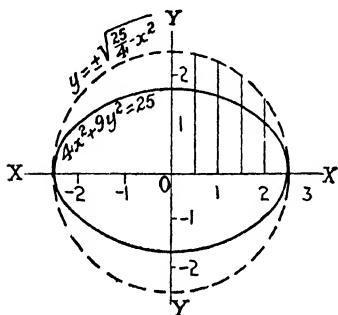

FIG. 44.

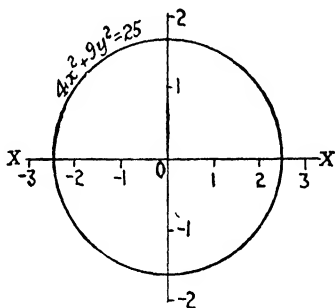

FIG. 45.

The ratio of the ordinates of the ellipse,  $4x^2 + 9y^2 = 25$ , to the ordinates of the circle,  $x^2 + y^2 = \frac{25}{4}$ , in Fig. 44 is

$$\sqrt{\frac{A}{C}} : 1 = \sqrt{\frac{4}{9}} : 1 = \frac{2}{3} : 1$$

The ordinates of the ellipse are two-thirds as long as the ordinates of the circle with radius of

$$\sqrt{-\frac{F}{A}} \text{ or } \frac{5}{2} \text{ units.}$$

A proportional divider set to a ratio of two-thirds can be used to reduce the ordinates of the circle to two-thirds of their length, and the graph of the required ellipse drawn through the terminals of the ordinates as shown. Another method is shown in Fig. 45 which uses the circle of radius  $\frac{5}{2}$  horizontal units but the unit length of the vertical scale is one and one-half times the length of

the horizontal unit. The graph then represents the implicit function,  $4x^2 + 9y^2 = 25$ .

201. In case  $A > 0$ ,  $C < 0$ , and  $F < 0$ , that is, if  $A$  is positive with both  $C$  and  $F$  negative in [18], the equation,  $Ax^2 + Cy^2 + F = 0$ ,

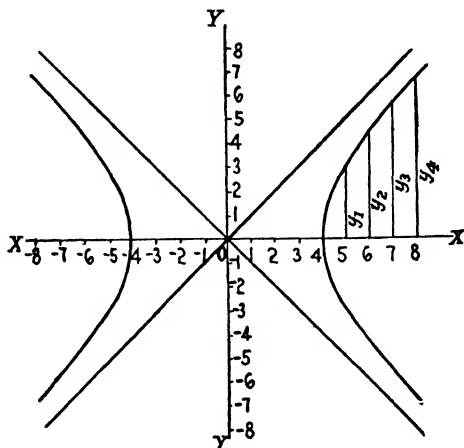

FIG. 46.

represents a different sort of a curve. The simplest example of this form of curve is that represented by the equation,

$$[25] \quad x^2 - y^2 = a^2.$$

In Fig. 46 the graph of  $x^2 - y^2 = 16$  crosses the  $X$ -axis at the points  $(4, 0)$  and  $(-4, 0)$ , and there are no points on the graph

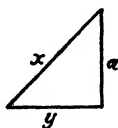

FIG. 47.

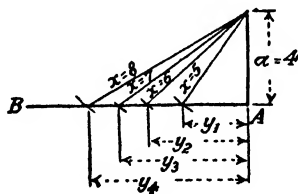

FIG. 48.

for values of  $x$  between 4 and  $-4$ . The graph is symmetrical with respect to both axes and consists of two branches. It is called an equilateral hyperbola.

The sides of the right triangle (Fig. 47) illustrate the relation of  $x$ ,  $y$ , and  $a$  in  $x^2 - y^2 = a^2$ . By taking different values of  $x$ ,



as 1, 2, 3, etc. (Fig. 48), with a drafting compass and striking arcs across the base line  $AB$  the ordinates  $y$  of the equilateral hyperbola can be measured and transferred as the ordinates of the graph in Fig. 46.

202. If the equation of the locus is  $x^2 - y^2 = a^2$ , the points of intersection of the graph and the  $X$ -axis are  $(a, 0)$  and  $(-a, 0)$ . That is, the vertices of the curve are at distances  $a$  and  $-a$  from the origin. The diagonal lines are the asymptotes, drawn at an angle of  $45^\circ$  to the axes.

The equations of the asymptotes are, therefore,

$$y = x \text{ and} \\ y = -x.$$

If, in the general equation,  $A$  is positive and  $C$  and  $F$  are both negative, the equation takes the form,

[26] 
$$x^2 - n^2y^2 = a^2,$$

from which

[27] 
$$y = \pm \frac{1}{n} \sqrt{x^2 - a^2},$$

which shows by comparing with  $y = \sqrt{x^2 - a^2}$ , from  $x^2 - y^2 = a^2$  [25], that the ordinates are to each other as  $\frac{1}{n}$  is to 1, or  $\sqrt{\frac{A}{C}}:1$ .

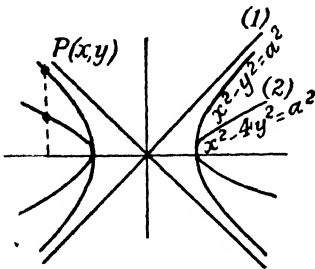

FIG. 49.

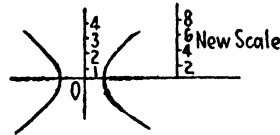

FIG. 50.

Referring to the graph of Fig. 49, we note that the ordinates of (1) are twice the length of the ordinates of (2), and we can, therefore, draw the graph of (2) from (1) by using proportional dividers, or we can use a graph of  $x^2 - y^2 = a^2$  and make the vertical scale of  $y$ , one-half as long as the scale of ordinates of the standard graph, as in Fig. 50.

The equation,  $x^2 - n^2y^2 = a^2$ , represents an hyperbola. The  $x$  intercepts are  $x = a$  and  $x = -a$ .

If  $F = 0$ , we have  $x^2 - n^2y^2 = 0$ , or  $(x - ny)(x + ny) = 0$ , which represents two straight lines, whose equations are  $x = ny$  and  $x = -ny$ , or the asymptotes of the hyperbola.

**203.** When  $A > 0$ ,  $C < 0$ , and  $F > 0$ , that is,  $A$  and  $F$  are positive and  $C$  is negative in [18], the equation,

$$Ax^2 + Cy^2 + F = 0,$$

represents an hyperbola whose transverse axis is the  $Y$ -axis. The simplest form is the equilateral hyperbola,

$$x^2 - y^2 = -a^2,$$

which may be written,

$$x = \pm \sqrt{y^2 - a^2}.$$

The points of intersection of the graph and the  $Y$ -axis are  $(0, a)$  and  $(0, -a)$ . The asymptotes are the diagonal lines drawn at an angle of  $45^\circ$  to the axes and have the same equations as the asymptotes of the equilateral hyperbola of the previous case (see Fig. 49).

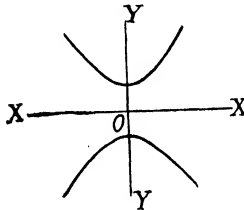

FIG. 51.

The general equation [18] takes the form,

$$Ax^2 + Cy^2 + F = 0,$$

which may be written,

$$[28] \quad n^2x^2 - y^2 = -a^2,$$

or

$$[29] \quad x = \pm \frac{1}{n} \sqrt{y^2 - a^2},$$

which shows, when compared with  $x = \pm \sqrt{y^2 - a^2}$  of the equilateral hyperbola of this form, that the abscissae are in the ratio of

$$\frac{1}{n} \text{ to } 1, \text{ or } \sqrt{\frac{C}{A}} \text{ to } 1.$$

The following example illustrates the method:

**EXAMPLE.**—Draw the graph of  $9x^2 - 25y^2 + 100 = 0$ .

Rearranging,

$$x^2 - y^2 = -4,$$

or

$$x = \pm \frac{1}{2} \sqrt{y^2 - 4},$$

which compared with  $x = \pm\sqrt{y^2 - 4}$ , the equilateral hyperbola having its transverse axis on the  $Y$ -axis, the ratio of the abscissae are  $\frac{1}{n}$  to 1 or 5 to 3. The right triangle is used as before except that the  $y$  values, as  $y = 3, y = 4, y = 5$ , etc., are taken on the hypotenuse and the corresponding  $x$  values for the equilateral hyperbola found as in Fig. 53. The proportional divider set to the ratio of 5 to 3 is used to transfer the measurements of the required  $x$  values and change the graph from

$$x = \pm\sqrt{y^2 - 4} \text{ to } x = \pm\frac{1}{3}\sqrt{y^2 - 4}.$$

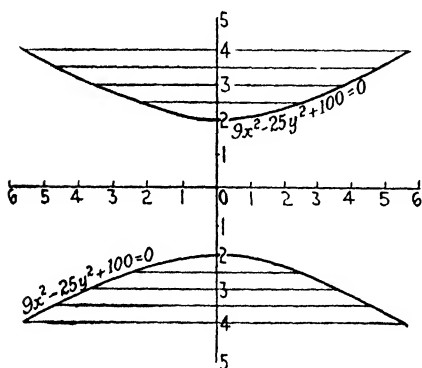

FIG. 52.

The short legs of the divider are set to the  $x$  values on the triangle and the long leg measurements used for measuring the abscissae of the required graph. These measurements are made horizontally from the  $Y$ -axis as in Fig. 52.

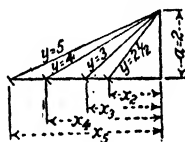

FIG. 53.

**204.** Since the terms  $Dx$  and  $Ey$  are translation terms of the general equation, their addition to the equations of the circle, ellipse, etc., changes the size but not the general shape of the graph in any respect but simply translates the center to a point different from the origin. Therefore  $Ax^2 + Cy^2 + F + Dx + Ey = 0$  is still a circle if  $A = C$ , and  $Ax^2 + Cy^2 + F + Dx + Ey = 0$  is still the equation of an hyperbola if  $C$  and  $F$  are negative. The axis, however, will have a different location from the axis of  $Ax^2 + Cy^2 + F = 0$ . If in the general form the unknowns are increased or decreased by some fixed amount, and these amounts substituted for the given variables, the coordinate axes of the graph are translated.

**205.** If we take the general form of the quadratic with  $B = 0$ , we have

$$Ax^2 + Cy^2 + Dx + Ey + F = 0. \tag{1}$$

Completing the squares gives

$$A\left(x^2 + \frac{D}{A}x + \frac{D^2}{4A^2}\right) + C\left(y^2 + \frac{E}{C}y + \frac{E^2}{4C^2}\right) = \frac{D^2}{4A} + \frac{E^2}{4C} - F, \quad (2)$$

$$\text{or } A\left(x + \frac{D}{2A}\right)^2 + C\left(y + \frac{E}{2C}\right)^2 = \frac{D^2C + E^2A - 4ACF}{4AC}.$$

$$\text{Let } x = x_1 - \frac{D}{2A} \quad \text{and} \quad y = y_1 - \frac{E}{2C}.$$

Substitute these values in (2), which becomes

$$[30] \quad A(x_1)^2 + C(y_1)^2 = \frac{D^2C + E^2A - 4ACF}{4AC},$$

in which  $\frac{D^2C + E^2A - 4ACF}{4AC}$  is a constant,  $F' \neq F$ .

We can, therefore, transform the given equation to an equation which represents the same locus referred to a different system of axes, and we can so choose the second system of axes as to make the first-degree terms in  $x$  and  $y$  disappear. This translation of axes does not change the coefficients of the  $x^2$  and the  $y^2$  terms. The constant term of the transformed equation will be, from [30] above,

$$[31] \quad F' = \frac{4ACF - D^2C - E^2A}{4AC}.$$

It will be seen that the transformed equation, *i.e.*,  $A(x_1)^2 + C(y_1)^2 + F' = 0$ , is of the form,  $Ax^2 + Cy^2 + F = 0$ , which, as we have already shown, represents either an ellipse (considering the circle to be a particular case of the ellipse in which  $A = C$ ) or an hyperbola having its center at the origin. If we draw the graph of the transformed equation and then locate a new set of axes for which  $x = x_1 - h$  and  $y = y_1 - k$ , the graph referred to the new axes will represent the locus of  $Ax^2 + Cy^2 + Dx + Ey + F = 0$ . But from the above discussion it is evident that

$$[32] \quad h = \frac{D}{2A} \quad \text{and}$$

$$[33] \quad k = \frac{E}{2C},$$

where  $h$  and  $k$  are the coordinates of the new origin.

EXAMPLE.—Draw the graph of  $9x^2 + 16y^2 - 18x + 64y - 8 = 0$ . Arranging the terms,

$$9x^2 + 16y^2 - 18x + 64y - 8 = 0.$$

$$h = \frac{D}{2A} = \frac{-18}{2 \cdot 9} = -1 \text{ from [32].}$$

$$k = \frac{E}{2C} = \frac{64}{2 \cdot 16} = 2 \text{ from [33].}$$

We see by inspection that the graph is an ellipse and that the origin is 1 unit to the left and 2 units above the center of the ellipse.

We can draw the graph of the transformed equation,  $Ax_1^2 + Cy_1^2 + F'' = 0$  [30], much more easily than we can draw the graph of the original equation. Therefore, we draw the graph of  $9(x_1)^2 + 16(y_1)^2 = 81$ , (Art. 200) which is an ellipse with its center at the origin of the coordinate system  $O_1X_1, O_1Y_1$ , as shown in Fig. 54.

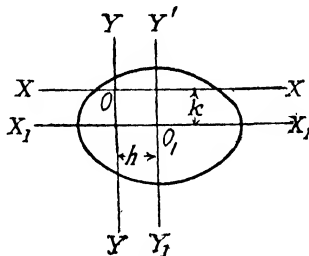

FIG. 54.

The equation of the same ellipse, referred to the system of coordinates whose origin is at  $(-1, 2)$ , is the given equation above, namely,  $9x^2 + 16y^2 - 18x + 64y - 8 = 0$ .

Now if we have the above equation taken simultaneously with another equation whose graph is a straight line, we solve for value of  $x$  and  $y$  very readily by locating the intersections of the ellipse and the straight line.

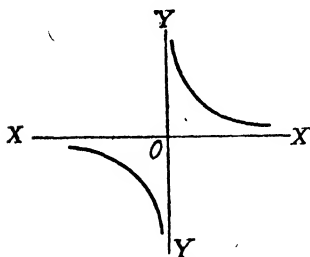

FIG. 55.

If the graph has any intersections with the  $X$ -axis, the abscissae of these points denote those values of  $x$  which make the function equal to zero; that is, the roots of the equation and similarly the intersections of the ellipse and the  $Y$ -axis denote the values of  $y$  which make the function equal to zero.

206. Case where  $Bxy + F = 0$ .—This is the equation of an hyperbola having the  $X$ - and the  $Y$ -axes as asymptotes, as shown in Fig. 55.

By transposing  $F$  and dividing by  $B$ , we get

$$[34] \quad xy = -\frac{F}{B} = \text{some constant} = C.$$

When two variables change in such a manner that their product is always equal to a constant, the graph of the equation is an equilateral hyperbola having the coordinate axes as asymptotes. Thus, the graph of  $pv = C$ , the equation from physics connecting the pressure  $p$  and the volume  $v$  of a gas confined under pressure. For a rapid method of computing the ordinates, see Arts. 397 and 406 of the Slide Rule section.

207. If  $A = C = 0$  and  $B \neq 0$ , the general equation takes the form,

$$[35] \quad Bxy + Dx + Ey + F = 0,$$

which can be written,

$$xy + \frac{D}{B}x + \frac{E}{B}y + \frac{F}{B} = 0,$$

or

$$xy + \frac{D}{B}x + \frac{E}{B}y = -\frac{F}{B}.$$

Adding  $\frac{ED}{B^2}$  to both members of the equation,

$$xy + \frac{D}{B}x + \frac{E}{B}y + \frac{ED}{B^2} = \frac{ED}{B^2} - \frac{F}{B}.$$

Then

$$y\left(x + \frac{E}{B}\right) + \frac{D}{B}\left(x + \frac{E}{B}\right) = \frac{ED - BF}{B^2},$$

or

$$[36] \quad \left(x + \frac{E}{B}\right)\left(y + \frac{D}{B}\right) = \frac{ED - BF}{B^2}.$$

If we make the transformation  $x_1 = x + h$ , and  $y_1 = y + k$ , where  $h = \frac{E}{B}$  and  $k = \frac{D}{B}$ , then [36] takes the simple form,

$$x_1y_1 = C,$$

where the constant term  $C = \frac{ED - BF}{B^2}$ .

Therefore, the graph of  $Bxy + Dx + Ey + F = 0$  can be constructed by drawing the graph of

$$x_1y_1 = \frac{ED - BF}{B^2}$$

and translating the origin to  $(h, k)$ , where

$$[37] \quad h = \frac{E}{B} \quad \text{and} \quad k = \frac{D}{B}.$$

EXAMPLE.—Draw the graph of  $2xy + x + 2y = 9$ .

$$B = 2, D = 1, E = 2, F = -9.$$

$$h = 1, k = \frac{1}{2}, C = \frac{2 \times 1 - 2(-9)}{4} = 5.$$

Draw the graph of  $xy = 5$ ; then move the origin to  $(1, \frac{1}{2})$  (Fig. 56).

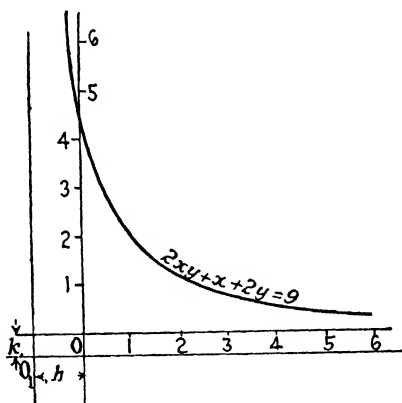

FIG. 56.

### 208. Shearing in the general equation,

$$Ax^2 + Bxy + Cy^2 + Dx + Ey + F = 0 \quad [13]$$

When the  $Bxy$  term is present, the equation can be reduced to a simple form for graphing by what is known as the shearing method. The following example will illustrate the method: Consider the equation,

$$y^2 - 2xy + x^2 - 2x - 3 = 0. \quad (1)$$

Solving for  $y$ ,

$$y = x \pm \sqrt{2x + 3}. \quad (2)$$

If equation (2) is divided into two parts, as

$$y' = x \quad \text{and} \quad (3)$$

$$y'' = \pm \sqrt{2x + 3}, \quad (4)$$

then

$$y = y' + y''.$$

The ordinates of (2) equal the ordinates of (4) added to or subtracted from the ordinates of (3). The graphs of (3) and (4)

are constructed as in Fig. 57 on the same coordinate axes; then a third graph is made by transferring the ordinates of (4) or measuring from the linear graph instead of from the  $X$ -axis. The ordinates  $AC$  and  $AF$  are transferred to  $BD$  and  $BE$  for  $x = 1$ ; also  $A'C'$  and  $A'F'$  to  $B'D'$  and  $B'E'$  for  $x = 2$  and so on. This procedure is called shearing the equation,  $y = \pm\sqrt{2x+3}$ ,

with respect to the line  $y = x$  or line of shear. The line of shear, however, is not the axis of the conic.

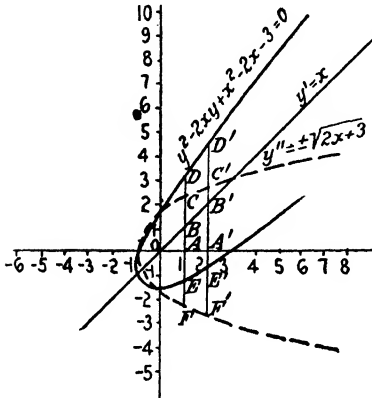

Fig. 57.

With a few exceptions, all conics of the general form,  $Ax^2 + Bxy + Cy^2 + Dx + Ey + F = 0$  where  $B \neq 0$ , can be arranged to use the shearing method. If  $C = 0$ , the process will not work, but the equation may then be solved for  $x$ , provided  $A \neq 0$ . If  $A$  and  $C$  are both zero, this shearing process will not go, as in the simple case,  $xy = C$ .

Consider the general equation, when  $C \neq 0$ .

$$Ax^2 + Bxy + Cy^2 + Dx + Ey + F = 0.$$

Rearranging and completing the square,

$$y^2 + \frac{Bx + E}{C}y + \frac{(Bx + E)^2}{4C^2} = \frac{-Ax^2 - Dx - F}{C} + \frac{B^2x^2 + 2BEy + E^2}{4C^2}.$$

$$\left(y + \frac{Bx + E}{2C}\right)^2 = \frac{(B^2 - 4AC)x^2 + (2BE - 4CD)x + (E^2 - 4CF)}{4C^2}.$$

$$[38] \quad y = -\frac{B}{2C}x - \frac{E}{2C} \pm \sqrt{\frac{(B^2 - 4AC)x^2 + (2BE - 4CD)x + (E^2 - 4CF)}{4C^2}}.$$

The general equation is now arranged to shear the conic,

$$[39] \quad y = \pm \sqrt{\frac{(B^2 - 4AC)x^2 + (2BE - 4CD)x + (E^2 - 4CF)}{4C^2}},$$

or

$$[40] \quad (B^2 - 4AC)x^2 - 4C^2y^2 + (2BE - 4CD)x + (E^2 - 4CF) = 0$$

with respect to the line,

$$[41] \quad y = -\frac{B}{2C}x - \frac{E}{2C}.$$



Conics of the form [40] have been treated in Arts. 196 to 206. A few examples of shearing follow:

EXAMPLE 1.—Construct the graph of

$$5x^2 - 4xy + y^2 - 12x + 11 = 0.$$

$$A = 5, B = -4, C = 1, D = -12, E = 0, F = 11.$$

The line of shear from [41] is

$$y = -\frac{-4}{2}x, \text{ or } y = 2x.$$

Substituting coefficients in [40],

$$(16 - 20)x^2 - 4y^2 + (0 + 48)x + (0 - 44) = 0,$$

which reduces to the conic,

$$x^2 + y^2 - 12x + 11 = 0.$$

The conic represented by this last equation is a circle, and in order to locate its origin and find its radius, equations [30], [32], [33] will be used.

Equation [30] with new coefficients becomes

$$x^2 + y^2 = \frac{144 + 0 - 4 \times 11}{4} = 25.$$

Equation [32] becomes

$$h = \frac{-12}{2} = -6.$$

Equation [33] becomes

$$k = \frac{0}{2} = 0.$$

The equation,  $x^2 + y^2 = 25$ , of the circle has a radius of five units, and the origin, to transform the graph to  $x^2 + y^2 - 12x + 11 = 0$ , is located at  $(-6, 0)$  from the center of the circle. The circle and the line of shear are next drawn, and the ordinates transferred from the circle by a divider, using the shear line as the base line as shown in Fig. 58.

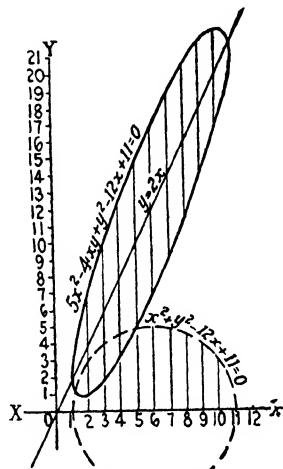

FIG. 58.

EXAMPLE 2.—Construct the graph of

$$2x^2 + 4xy + 4y^2 - 4x - 12 = 0.$$

$$A = 2, B = 4, C = 4, D = -4, E = 0, F = -12.$$

Substituting in [40],

$$(16 - 32)x^2 - 64y^2 + (0 + 64)x + (0 + 192) = 0.$$

Simplifying,

$$x^2 + 4y^2 - 4x - 12 = 0.$$

This equation represents an ellipse and is the conic which is to be sheared.

Substituting the coefficients in [41], the line of shear is

$$y = -\frac{1}{2}x - 0, \text{ or } y = -\frac{1}{2}x.$$

The negative sign indicates that the slope of this line of shear is negative.

To get more particulars of the conic,  $x^2 + 4y^2 - 4x - 12 = 0$ , the equation [30] will be used with new coefficients.

$$A = 1, C = 4, D = -4, E = 0, F = -12.$$

Substituting in [30], [32], [33],

$$x^2 + 4y^2 = \frac{(16)(4) - (4)(1)(4)(-12)}{(4)(4)},$$

or

$$x^2 + 4y^2 = 16.$$

$$h = -\frac{1}{2}, k = 0.$$

Either the ellipse,  $x^2 + 4y^2 = 16$ , with the origin translated to  $(-2, 0)$  (which will then represent  $x^2 + 4y^2 - 4x - 12 = 0$ ), can be used, or a circle with the proper radius substituted for the ellipse and the ordinates taken with the proportional

divider as in Art. 200. The last method will be shown.

The equation,  $x^2 + 4y^2 = 16$ , can be put into the form,  $y = \pm \frac{1}{2}\sqrt{16 - x^2}$ , which compared to the equation,  $y = \pm \sqrt{16 - x^2}$ , of the circle, indicates that the ordinates of the ellipse are half as long as the corresponding ordinates of the circle. The circle is drawn with center located at  $(2, 0)$  and radius equal to four units. The

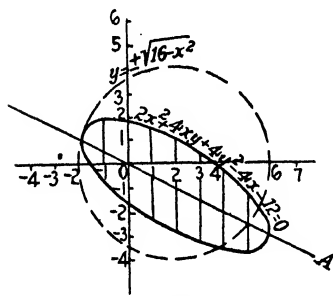

FIG. 59.

proportional divider set to  $\frac{1}{2}:1$  is used to transfer the ordinates to the sheared line  $OA$  as shown by Fig. 59 in the ratio of  $\frac{1}{2}:1$ .

EXAMPLE 3.—Construct the graph of

$$x^2 - 4xy + y^2 + 4\sqrt{2}x - 2\sqrt{2}y + 11 = 0.$$

$$A = 1, B = -4, C = 1, D = 4\sqrt{2}, E = -2\sqrt{2}, F = 11.$$

Substituting in [40],

$$[16 - (4)(1)(1)]x^2 - 4y^2 + \{(2)(-4)(-2\sqrt{2}) - (4)(1)(4\sqrt{2})\}x + [8 - (4)(1)(11)] = 0.$$

Reducing,

$$x^2 - \frac{1}{2}y^2 = 3.$$

Substituting coefficients in [41], the line of shear is

$$y = -\frac{-4}{2}x - \frac{-2\sqrt{2}}{2}$$

or

$$y = 2x + \sqrt{2}$$

The equation,  $x^2 - \frac{1}{3}y^2 = 3$ , when compared to the equilateral hyperbola equation,  $x^2 - y^2 = 3$ , shows that  $n = \sqrt{\frac{1}{3}}$  and that the ratio of the ordinates is  $\frac{1}{n}:1$ , or  $\frac{1}{\sqrt{\frac{1}{3}}}:1$ , or 1.735:1. In this case the ordinates of the required graph measured from the line of shear are longer than the ordinates of the equilateral hyperbola.

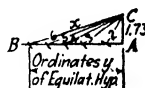

FIG. 60.

Draw a vertical line  $AC$  as in Fig. 60 equal to  $\sqrt{3}$  or 1.735, and with a compass set to  $x = 2, 3, 4$ , etc., with  $C$  as a center, strike arcs on the horizontal line  $AB$  as was done in Art. 201. These arcs measured from  $A$  give the ordinates of the equilateral hyperbola which correspond to  $x = 2, x = 3, x = 4$ , etc. With a proportional divider set to the ratio of 1.735:1, measure these  $y$  values

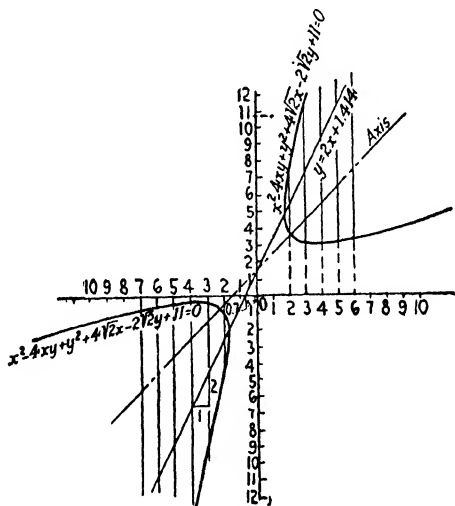

FIG. 61.

which correspond to each  $x$  value with the short legs of the divider and transfer the long-leg measurement of the divider for the points on the required graph, measuring from the line of shear, as in Fig. 61.

209. The conics to be sheared in all cases reduce to the simple graphs of the parabola, ellipse, and hyperbola, with the exception of a few cases which reduce to points or to straight lines.

There are cases, however, such as parabolas and hyperbolas having the line of shear nearly perpendicular to the  $X$ -axis, or a slope much greater than  $\pm 45^\circ$ , where it is advisable to construct the graphs from the  $Y$ -axis as previously given (Art. 203). This must be done if  $C = 0$ ,  $A \neq 0$ .

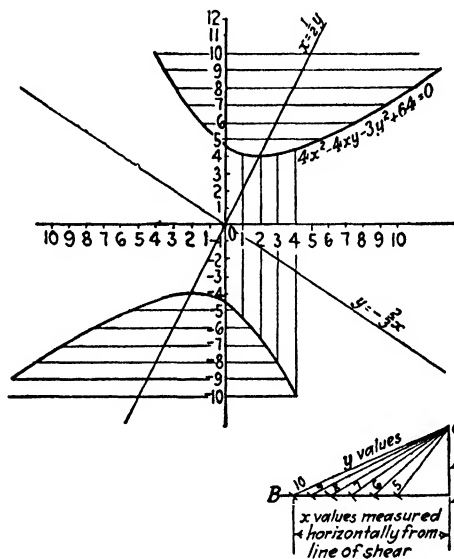

FIG. 62.

The general equation,  $Ax^2 + Bxy + Cy^2 + Dx + Ey + F = 0$ , when arranged for the modified method, becomes

$$[42] \quad (B^2 - 4AC)y^2 - 4Ax^2 + (2BD - 4AE)y + (D^2 - 4AF) = 0.$$

The line of shear is

$$[43] \quad x = -\frac{B}{2A}y - \frac{D}{2A}.$$

These equations are found by solving for  $x$  instead of for  $y$  as was done in [40] and [41].

EXAMPLE 4.—Construct the graph of

$$4x^2 - 4xy - 3y^2 + 64 = 0.$$

$$A = 4, B = -4, C = -3, D = 0, E = 0, F = 64.$$

Substituting in [42],

$$[16 - (4)(4)(-3)]y^2 - (4)(16)x^2 + (0 - 0)x + [0 - (4)(4)(64)] = 0.$$

Reducing,

$$y^2 - x^2 = 16.$$

This represents a curve whose transverse axis is the Y-axis (Art. 203). It is the conjugate hyperbola of  $x^2 - y^2 = 16$ . The line of shear is

$$x = -\frac{-4}{(2)(4)}y - \frac{0}{8}, \text{ or } x = \frac{1}{2}y.$$

Different values of  $x$  for  $y = 1, y = 2, y = 3$ , etc. (Fig. 62) are plotted horizontally, measuring from the line of shear using the right-triangle method as before. The line of shear should first be found in order to know whether equations [40] and [41] or [42] and [43] should be used. The shear line from equation [41] and some of the ordinates of equation [40] are also indicated on the graph for comparing the two methods.

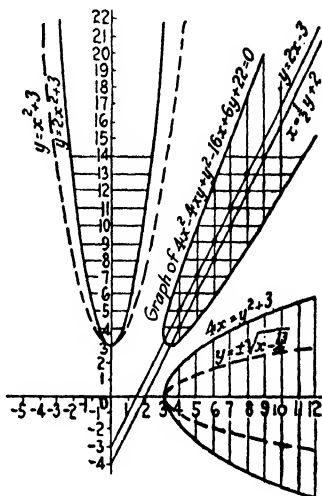

FIG. 63.

EXAMPLE 5.—Construct the graph of  $4x^2 - 4xy + y^2 - 16x + 6y + 22 = 0$ . The shear line from [41] is  $y = 2x - 3$  and from [43] is  $x = \frac{1}{2}y + 2$ . Both of these lines have steep slopes, and the natural formulae to use would

be [42] and [43], but for illustrative purposes, both methods will be used

$$4x^2 - 4xy + y^2 - 16x + 6y + 22 = 0.$$

$$A = 4, B = -4, C = 1, D = -16, E = 6, F = 22.$$

Substituting in [42],

$$2x^2 = y - 3, \text{ or } x = \pm .707\sqrt{y - 3}.$$

If the vertex of the standard graph,  $y = x^2$ , or  $x = \pm\sqrt{y}$ , of the parabola is placed at  $(0, 3)$ , it will then represent  $x = \pm\sqrt{y - 3}$ , and its axis of symmetry will coincide with the Y-axis. The ratio of the abscissae of  $x = \pm .707\sqrt{y - 3}$  to  $x = \pm\sqrt{y - 3}$  is .707 to 1. With the proportional divider set to .7 to 1, the abscissae are transferred to the shear line  $x = \frac{1}{2}y + 2$  as in the previous examples.

If formulae [40] and [41] are used, the conic to be sheared is

$$4x = y^2 + 13, \text{ or } y = \pm 2\sqrt{x - \frac{13}{4}}.$$

By using the standard graph,  $x = y^2$ , or  $y = \pm\sqrt{x}$ , with the vertex at  $(\frac{1}{4}, 0)$ , it will represent the equation,  $y = \sqrt{x - \frac{1}{4}}$ . The ratio of the ordinates of the conic,  $y = \pm 2\sqrt{x - \frac{1}{4}}$ , as now placed is 2:1. The proportional divider set to 2:1 is used to transfer the ordinates to the shear line,  $y = 2x - 3$ . These graphs all represent parabolas (see Fig. 63).

**210. Homogeneous Quadratic Equations.**—A homogeneous equation is an equation all of whose terms are of the same degree in the unknowns. A homogeneous quadratic equation is of the form,

$$[44] \quad Ax^2 + Bxy + Cy^2 = 0.$$

An equation of this form can always be factored.

Dividing by  $Ay^2$  and completing the square,

$$\left(\frac{x^2}{y^2}\right) + \frac{B}{A}\left(\frac{x}{y}\right) + \frac{B^2}{4A^2} = \frac{B^2}{4A^2} - \frac{C}{A}.$$

Extracting the square root,

$$[45] \quad \begin{aligned} \frac{x}{y} + \frac{B}{2A} &= \pm \sqrt{\frac{B^2 - 4AC}{4A^2}}. \\ \frac{x}{y} &= \frac{-B \pm \sqrt{B^2 - 4AC}}{2A}. \end{aligned}$$

It is interesting to note that the ratio of the unknowns as given by [45] has the same value as the unknown in the explicit form,  $ax^2 + bx + c = 0$  (Arts. 182 and 183).

Equation [45] can also be put into the form,

$$[46] \quad \begin{aligned} x - \left(\frac{-B + \sqrt{B^2 - 4AC}}{2A}\right)y &= 0. \\ x - \left(\frac{-B - \sqrt{B^2 - 4AC}}{2A}\right)y &= 0. \end{aligned}$$

The linear equations can now be found by the direct substitution of the coefficients of [44] in equations [46] and solved simultaneously with the other given quadratic equations as indicated in the previous articles (196) to (210).

The equation [44] in the factored form is

$$[47] \quad A\left(x - \frac{-B + \sqrt{B^2 - 4AC}}{2A}y\right)\left(x - \frac{-B - \sqrt{B^2 - 4AC}}{2A}y\right) = 0.$$

The factors can also be found by solving for  $y$  in terms of  $x$ , and the linear equations become

$$[48] \quad y = \frac{-B + \sqrt{B^2 - 4AC}}{2C} x \text{ and}$$

$$y = \frac{-B - \sqrt{B^2 - 4AC}}{2C} x.$$

If one of two simultaneous quadratic equations is homogeneous, the equations may be solved by factoring the homogeneous equation.

EXAMPLE.—Solve

$$x^2 - 3y^2 + 2y = 3. \tag{a}$$

$$2x^2 - 7xy + 6y^2 = 0. \tag{b}$$

Equation (b) has the form [44] and therefore can be factored

$$A = 2, B = -7, C = 6.$$

Substituting in [46],

$$x - \frac{(7 + \sqrt{49 - (4)(2)(6)})}{(2)(2)}y = 0.$$

$$x - 2y = 0, \text{ or } x = 2y.$$

Also,

$$x - \frac{7 - \sqrt{49 - (4)(2)(6)}}{(2)(2)}y = 0.$$

$$x - \frac{3}{2}y = 0, \text{ or } x = \frac{3}{2}y.$$

Substitute  $x = 2y$  and  $x = \frac{3}{2}y$  in (a), which gives

$$x = 2, + 6, 2 + \sqrt{-5}, 2 - \sqrt{5}.$$

$$y = 1, -3, \frac{4 + 2\sqrt{-5}}{3}, \frac{4 - 2\sqrt{-5}}{3}.$$

### 211. Simultaneous Quadratic Equations of the Form,

$$[49] \quad Ax^2 + Bxy + Cy^2 + F = 0 \text{ and}$$

$$[50] \quad A_1x^2 + B_1xy + C_1y^2 + F_1 = 0.$$

By multiplying [49] by  $F_1$  and [50] by  $F$  and subtracting [50] from [49], the constant terms  $F$  and  $F_1$  will be eliminated and the resulting equation will be homogeneous and can be factored.

$$[51] \quad (AF_1 - A_1F)x^2 + (BF_1 - B_1F)xy + (CF_1 - C_1F)y^2 = 0.$$

Dividing through by  $(AF_1 - A_1F)y^2$  and completing the square as in Art. 181 and reducing,

$$\frac{x}{y} = \frac{BF_1 - B_1F \pm \sqrt{(B^2 - 4AC)F_1^2 + (B_1^2 - 4A_1C_1)F^2 - 2FF_1[BB_1 - 2(A_1C + AC_1)]}}{2(A_1F - AF_1)}$$

The linear equations which replace [51] after factoring are

$$[52] \quad x = \frac{BF_1 - B_1F + \sqrt{(B^2 - 4AC)F_1^2 + (B_1^2 - 4A_1C_1)F^2 - 2(A_1F - AF_1)2FF_1[BB_1 - 2(A_1C + AC_1)]}}{2(A_1F - AF_1)}y$$

and

$$[53] \quad x = \frac{BF_1 - B_1F - \sqrt{(B^2 - 4AC)F_1^2 + (B_1^2 - 4A_1C_1)F^2 - 2(A_1F - AF_1)2FF_1[BB_1 - 2(A_1C + AC_1)]}}{2(A_1F - AF_1)}y$$

The linear equations can be formed by the direct substitution of the coefficients,  $A$ ,  $B$ ,  $C$ , etc., taken from the given equations. To complete the solutions, combine each of the linear equations [52] and [53] with either equation [49] or [50], and solve simultaneously either analytically or graphically.

EXAMPLE.—Solve

$$2x^2 - 3xy + 4 = 0. \quad (1)$$

$$4xy - 5y^2 - 3 = 0. \quad (2)$$

$$A = 2, B = -3, C = 0, F = 4.$$

$$A_1 = 0, B_1 = 4, C_1 = -5, F_1 = -3.$$

Substituting in formula [52],

$$x = \frac{(-3)(-3) - (4)(4) \pm \sqrt{(9 - 0)9 + (16 - 0)16 - 2[0 - (2)(-3)](2)(4)(-3)\{(-3)(4) - 2[0 + (2)(-5)]\}}}{2[0 - (2)(-3)]}y = \frac{9 - 16 + 23}{12}y = \frac{4}{3}y.$$

or

$$x = \frac{1}{3}y.$$

Likewise from [53],

$$x = \frac{9 - 16 - 23}{12}y = -\frac{5}{2}y.$$

The two linear equations are

$$3x - 4y = 0 \text{ and}$$

$$2x + 5y = 0.$$

Solving with the given equations (1) and (2) gives

$$x = 4, -4, \frac{\sqrt{-5}}{2}, -\frac{\sqrt{-5}}{2} \text{ and}$$

$$y = 3, -3, -\frac{\sqrt{-5}}{5}, +\frac{\sqrt{-5}}{5}.$$

There are two real and two imaginary roots.



This form includes all forms of quadratic equations having the quadratic terms of the unknown (including the  $xy$  term which is a quadratic term), the constant terms, but not the first-degree terms. Any of the terms may be absent as noted in the last example; the  $Cy^2$  term is absent in (1) and the  $Ax^2$  term is absent in (2). Then  $C = 0$  and  $A_1 = 0$  in the formula.

Formulae [52] and [53] can be modified and reduced to a simpler form depending on which term is absent. As an example, consider the constant term  $F_1$  absent or  $F_1 = 0$ . Then

$$x = \frac{-B_1F \pm \sqrt{(B_1^2 - 4A_1C_1)F^2}}{2A_1F}y.$$

[54] 
$$x = \frac{-B \pm \sqrt{B_1^2 - 4A_1C_1}}{2A_1}y.$$

These linear equations can be taken with either of the given equations [49] or [50] and solved simultaneously as in Art. 210.

**212. Quadratic equations of the form,**

$$Ax^2 + Cy^2 + F = 0 \text{ and}$$

$$A_1x^2 + C_1y^2 + F_1 = 0 \text{ [18]}$$

Consider  $x^2$  and  $y^2$  as the unknowns and let  $u = x^2$  and  $v = y^2$ ; then substitute in both of the above equations. Then

$$Au + Cv + F = 0.$$

[55] 
$$A_1u + C_1v + F_1 = 0.$$

The last equations are straight-line or linear equations in  $u$  and  $v$  and from them  $u$  and  $v$  can be determined; then  $x$  and  $y$  can be found from

$$x = \pm\sqrt{u} \text{ and } y = \pm\sqrt{v},$$

EXAMPLE.—Solve

$$16x^2 + 27y^2 = 576. \tag{1}$$

$$x^2 + y^2 = 25. \tag{2}$$

$$A = 16, C = 27, F = -576.$$

$$A_1 = 1, C_1 = 1, F_1 = -25.$$

Substituting in [55],

$$16u + 27v = 576. \tag{3}$$

$$u + v = 25. \tag{4}$$

Multiply equation (4) by 27 and subtract from (3) to eliminate  $v$ .

$$16u + 27v = 576.$$

$$27u + 27v = 675.$$

$$11u = 99.$$

$$u = 9.$$

$$x = \pm 3.$$

Substituting  $u = 9$  in (4),

$$y = \pm 4.$$

Each value of  $x$  can be taken with each value of  $y$ , giving four combinations, or

$$(3, 4), (-3, 4), (3, -4), (-3, -4).$$

Another solution is to consider equations (1) a special form of the equations discussed in the previous article (211) with  $B = 0$  and  $B_1 = 0$ . The linear equations then reduce to

$$[56] \quad x = + \frac{\sqrt{F_1 F (A_1 C + A C_1) - A C F_1^2 - A_1 C_1 F^2}}{A_1 F - A F_1} y.$$

$$[57] \quad x = - \frac{\sqrt{F_1 F (A_1 C + A C_1) - A C F_1^2 - A_1 C_1 F^2}}{A_1 F - A F_1} y.$$

Solving the same problem by means of the formula,

$$\begin{aligned} x &= \pm \frac{\sqrt{25 \cdot 576(27 + 16) - 16 \cdot 27 \cdot 25 \cdot 25 - 1 \cdot 1 \cdot 576 \cdot 576}}{-576 - 16(-25)} y. \\ &= \pm \frac{\sqrt{619,200 - 270,000 - 331,776}}{-576 + 400} y = \pm \frac{132}{176} y = \pm \frac{3}{4} y. \end{aligned}$$

The linear equations are

$$4x + 3y = 0 \text{ and}$$

$$4x - 3y = 0$$

These equations can be combined with (1) and (2) of the example either by substitution, or since (2) is the equation of a circle, a graphical solution of the problem is very simple.

**213. Equations of the form,**

$$Ax^2 + Bxy + Cy^2 + Dx = 0,$$

$$[58] \quad A_1x^2 + B_1xy + C_1y^2 + D_1x = 0,$$

or

$$Ax^2 + Bxy + Cy^2 + Ey = 0,$$

$$A_1x^2 + B_1xy + C_1y^2 + E_1y = 0.$$

In both sets of equations, all the terms are of the same degree with respect to the unknowns, with the exception of the first-degree terms which, however, are similar in both equations. First, eliminate the first-degree term, obtaining a homogeneous equation, and then use formula [46] (Art. 210) for factoring, and solve the resulting linear equations simultaneously with one of the given equations, either analytically or graphically.

EXAMPLE.—Solve  $x^2 + 2xy = 6y$ . (1)

$$2x^2 - xy + y^2 = 4y. \quad (2)$$

Multiplying (1) by 2 and (2) by 3,

$$2x^2 + 4xy = 12y \text{ and} \quad (3)$$

$$6x^2 - 3xy + y^2 = 12y. \quad (4)$$

Subtracting (3) from (4),

$$4x^2 - 7xy + 3y^2 = 0, \quad (5)$$

which is a homogeneous equation and can be factored.

$$A = 4, B = -7, C = 3.$$

Using [46] (Art. 210),

$$x - \frac{7 + \sqrt{49 - 4 \cdot 4 \cdot 3}}{2 \cdot 4}y = 0.$$

$$x - \frac{7 + 1}{8}y = 0.$$

$$x = y = \text{one of the linear equations.} \quad (6)$$

Also,

$$x - \frac{7 - 1}{8}y = 0.$$

$$x = \frac{3}{4}y = \text{the other linear equation.} \quad (7)$$

Solving each of these linear equations simultaneously with (1),

$$x^2 + 2xy = 6y. \quad (1) \qquad x^2 + 2xy = 6y. \quad (1)$$

$$x = y. \quad (6) \qquad x = \frac{3}{4}y. \quad (7)$$

Substituting (6) in (1),

$$y^2 + 2y^2 - 6y = 0.$$

$$3y^2 - 6y = 0.$$

$$y^2 - 2y = 0.$$

Substituting (7) in (1),

$$\frac{9}{16}y^2 + \frac{3}{2}y^2 - 6y = 0.$$

$$33y^2 - 96y = 0.$$

$$11y^2 - 32y = 0.$$

Completing the square,

$$y^2 - 2y + 1 = 1.$$

$$y - 1 = \pm 1.$$

$$y = 2 \text{ or } 0.$$

$$121y^2 - 352y + 256 = 256.$$

$$11y - 16 = \pm 16.$$

$$y = \frac{32}{11} \text{ or } 0.$$

Therefore,

$$x = 2 \text{ or } 0.$$

Therefore,

$$x = \frac{32}{11} \text{ or } 0.$$

**214. Symmetrical Simultaneous Equations.**—An equation that is not affected by interchanging the unknowns is called a symmetrical equation, as

$$2x^2 + xy + 2y^2 = 4, \quad \text{or} \quad x^2 + y^2 + x + y = 8.$$

The typical form is

$$A(x^2 + y^2) + Bxy + D(x + y) + F = 0. \quad (1)$$

$$A_1(x^2 + y^2) + B_1xy + D_1(x + y) + F_1 = 0.$$

Let  $x = u + v$  and  $y = u - v$  and substitute in (1)  $A(u^2 + 2uv + v^2 + u^2 - 2uv + v^2) + B(u^2 - v^2) + D(2u) + F = 0$ , or by collecting and assuming both of the equations symmetrical,

$$(2A + B)u^2 + (2A - B)v^2 + 2Du + F = 0 \quad \text{(2)}$$

$$(2A_1 + B_1)u^2 + (2A_1 - B_1)v^2 + 2D_1u + F_1 = 0. \quad \text{(3)}$$

Equations (1) can be changed to quadratics in  $u$  and  $v$  by the direct substitution of coefficients,  $A, B, D$ , and  $A_1, B_1, D_1$ , in (2) and (3). Then  $v^2$  can be eliminated from (2) and (3) and the values of  $u$  and  $v$  found. Then by substitution in  $x = u + v$  and  $y = u - v$ , the unknowns  $x$  and  $y$  are found.

EXAMPLE.—Solve

$$x^2 + y^2 + x + y = 8. \quad \text{(a)}$$

$$xy + x + y = 5. \quad \text{(b)}$$

In the first equation (a),

$$A = 1, B = 0, D = 1, F = -8$$

which substituted in formula (2) gives

$$2u^2 + 2v^2 + 2u - 8 = 0,$$

or

$$u^2 + v^2 + u - 4 = 0. \quad \text{(c)}$$

In the second equation (b),

$$A_1 = 0, B_1 = 1, D_1 = 1, F_1 = -5$$

which substituted in formula (3) gives

$$u^2 - v^2 + 2u = 5. \quad \text{(d)}$$

Solving the two equations,

$$u^2 + v^2 + u = 4 \quad \text{and} \quad \text{(c)}$$

$$u^2 - v^2 + 2u = 5 \quad \text{(d)}$$

Eliminating  $v^2$  by adding (c) and (d),

$$2u^2 + 3u = 9, \quad \text{(e)}$$

from which

$$u = \frac{3}{2} \text{ or } -3.$$

The four solutions of (c) and (d) give

$$u = \frac{3}{2}, \frac{3}{2}, -3, -3.$$

$$v = \frac{1}{2}, -\frac{1}{2}, i\sqrt{2}, -i\sqrt{2}.$$

From  $x = v + u$  and  $y = u - v$ ,

$$x = 1, -3 + i\sqrt{2}, -3 - i\sqrt{2}.$$

$$y = 2, -3 - i\sqrt{2}, -3 + i\sqrt{2}.$$

EXAMPLE.—Solve

$$x^2 + y^2 + x + y = 8. \quad \text{(a)}$$

$$xy = 2. \quad \text{(b)}$$

From (2) (Art. 214),  $A = 1, B = 0, D = 1.$

From (3) (Art. 214),  $A_1 = 0$ ,  $B_1 = 1$ ,  $D_1 = 0$ .

$$2u^2 + 2v^2 + 2u = 8,$$

or

$$u^2 + v^2 + u = 4. \quad (c)$$

$$u^2 - v^2 = 2. \quad (d)$$

Eliminating  $v^2$  by addition,

$$2u^2 + u = 6.$$

Completing the square,

$$4u^2 + 2u + \frac{1}{4} = 12\frac{1}{4}.$$

$$2u + \frac{1}{2} = \pm\frac{7}{2} \text{ and } u = \frac{3}{2}, -2.$$

The substitution of  $u = \frac{3}{2}$  in (c) gives  $v = \pm\frac{1}{2}$  and the substitution of  $u = -2$  in (c) gives  $v = \pm\sqrt{2}$ .

The values of  $u$  and  $v$  are then

$$u = \frac{3}{2}, \frac{3}{2}, -2, -2.$$

$$v = \frac{1}{2}, -\frac{1}{2}, +\sqrt{2}, -\sqrt{2}.$$

$$x = \frac{3}{2} + \frac{1}{2}, \frac{3}{2} - \frac{1}{2}, -2 + \sqrt{2}, -2 - \sqrt{2}.$$

$$y = \frac{1}{2} - \frac{1}{2}, \frac{1}{2} + \frac{1}{2}, -2 - \sqrt{2}, -2 + \sqrt{2}.$$

**215. Symmetrical Except as to Sign.**—If one of the equations is symmetrical and the other symmetrical except the signs, solve the problem by first finding the values of  $x + y$  and  $x - y$ .

EXAMPLE.—Find the roots of

$$x^2 + y^2 = 68. \quad (1)$$

$$x - y = 6. \quad (2)$$

Squaring (2),

$$x^2 - 2xy + y^2 = 36. \quad (3)$$

Subtracting (3) from (1),

$$2xy = 32. \quad (4)$$

Adding (4) and (1),

$$x^2 + 2xy + y^2 = 100.$$

Extracting the square root,

$$x + y = \pm 10. \quad (5)$$

From (5) and (2),

$$x = 8, \text{ or } -2.$$

$$y = 2, \text{ or } -8.$$

**216. Equations of higher degree,** when symmetrical or symmetrical except as to sign, can often be solved by substituting  $x = u + v$  and  $y = u - v$ .

EXAMPLE.—Find the roots of

$$x^4 + y^4 = 272. \quad (1)$$

$$x - y = 2. \quad (2)$$

Assume  $x = u + v$  and  $y = u - v$ . Then

$$u^4 + 4u^3v + 6u^2v^2 + 4uv^3 + v^4 + u^4 - 4u^3v + 6u^2v^2 - 4uv^3 + v^4 = 272. \quad (3)$$

From (2),

$$2v = 2 \text{ or } v = 1. \quad (4)$$

Dividing (3) by 2,

$$u^4 + 6u^2v^2 + v^4 = 136. \quad (5)$$

Substituting 1 for  $v$  in (5) and solving,

$$u = \pm 3 \text{ or } \pm \sqrt{-15}.$$

Substituting these values for  $u$  and  $v$  in  $x = u + v$  and  $y = u - v$  gives

$$x = 4, -2, 1 + \sqrt{-15}, 1 - \sqrt{-15}.$$

$$y = 2, -4, -1 + \sqrt{-15}, -1 - \sqrt{-15}.$$

**217. Solving by  $x$  and  $y$  Functions.**—Many simultaneous equations may be readily solved by finding values for any two of the expressions,  $x + y$ ,  $x - y$ ,  $xy$ , as well as other functions of  $x$  and  $y$  from which the values of  $x$  and  $y$  may be obtained.

EXAMPLE.—Find the roots of

$$x^2 + 4y^2 - 15(x - 2y) + 80 = 0. \quad (1)$$

$$xy = 6. \quad (2)$$

Multiplying (2) by 4 and subtracting from (1),

$$x^2 - 4xy + 4y^2 - 15(x - 2y) + 56 = 0.$$

Solve for the function,  $x - 2y$ , and then for  $x$  and  $y$ .

EXAMPLE.—Solve

$$x^2 + xy = 12. \quad (1)$$

$$xy + y^2 = 4. \quad (2)$$

Adding (1) and (2),

$$x^2 + 2xy + y^2 = 16. \quad (3)$$

Subtracting (2) from (1),

$$x^2 - y^2 = 8. \quad (4)$$

Extracting the square root of (3),

$$x + y = \pm 4. \quad (5)$$

Dividing (4) by (5),

$$x - y = \pm 2. \quad (6)$$

Combining (5) and (6),

$$x = 3 \text{ or } -3 \text{ and } y = 1 \text{ or } -1.$$

The first value of  $x - y$  corresponds only to the second value of  $x + y$ . Consequently, there are only two pairs of values of  $x$  and  $y$ .

Special methods of reduction are often used by first solving in terms of

$$\sqrt{xy}, \sqrt{x + y}, \frac{1}{x}, \frac{1}{y}, xy, x^2, (x + y), (x + y)^2, x^2y, \text{ etc.},$$

and then finding  $x$  and  $y$ . It is sometimes more convenient to introduce new variables, as  $\sqrt{xy} = u$ , etc. The most common are

$$x = u + v, \quad y = u - v, \quad y = vx.$$

The equations can often be combined into simple forms by inspection with slight modifications of the forms as given.

EXAMPLE.—Find the roots of

$$\frac{1}{x^2} + \frac{1}{y^2} = 52. \quad (1)$$

$$\frac{1}{x} - \frac{1}{y} = 2. \quad (2)$$

Squaring (2),

$$\frac{1}{x^2} - \frac{1}{2xy} + \frac{1}{y^2} = 4. \quad (3)$$

Subtracting (3) from (1),

$$\frac{1}{2xy} = 48. \quad (4)$$

Adding (4) to (1),

$$\frac{1}{x^2} + \frac{1}{2xy} + \frac{1}{y^2} = 100.$$

Extracting the square root,

$$\frac{1}{x} + \frac{1}{y} = \pm 10. \quad (5)$$

$$\frac{1}{x} - \frac{1}{y} = 2. \quad (2)$$

Adding (2) and (5),

$$\frac{2}{x} = 12 \text{ or } -8.$$

$$\frac{1}{x} = 6 \text{ or } -4.$$

$$x = \frac{1}{-4}, \text{ or } \frac{1}{6}.$$

EXAMPLE.—Solve

$$x + y + \sqrt{x + y} = 20.$$

$$x - y - \sqrt{x - y} = 6.$$

Consider  $\sqrt{x + y}$  and  $\sqrt{x - y}$ , the unknown quantities first, and then solve for  $x$  and  $y$ .

**218. Division of One Equation by the Other.**—A pair of higher degree equations can often be solved by dividing one by the other.

EXAMPLE.—  $x^4 + x^2y^2 + y^4 = 336.$  (1)

$$x^2 - xy + y^2 = 12. \quad (2)$$

Divide (1) by (2), which gives

$$x^2 + xy + y^2 = 28. \quad (3)$$

Subtracting (2) from (3),

$$\begin{aligned} 2xy &= 16. \\ xy &= 8. \end{aligned} \quad (4)$$

Adding (3) and (4), and extracting the square root,

$$x + y = \pm 6. \quad (5)$$

Subtracting (4) from (2),

$$x^2 - 2xy + y^2 = 4.$$

Extracting the square root,

$$x - y = \pm 2. \quad (6)$$

From (5) and (6),

$$\begin{aligned} x &= 4, 2, -2, -4. \\ y &= 2, 4, -4, -2. \end{aligned}$$

Since (5) and (6) have been derived independently, with the first value of  $x + y$ , we associate each value of  $x - y$  in succession, and with the second value of  $x + y$ , each value of  $x - y$  in succession in the same order. Consequently, there are four pairs of values of  $x$  and  $y$ .

**219. Equations Containing Three Unknowns.**—In this case, combine two of the equations, according to preceding sections, and then combine the resulting equation with the third equation which should be the equation having the unknowns in the simplest form.

EXAMPLE.—  $x^2 + y^2 + z^2 = 30.$  (1)

$$xy + yz + zx = 17. \quad (2)$$

$$x - y - z = 2. \quad (3)$$

Add two times (2) to (1) and extract the square root of the result, getting (4) and then combine (4) with (3).

EXAMPLE.—Find the roots of

$$x^2 + y^2 + z^2 = 81. \quad (1)$$

$$x + y + z = 14. \quad (2)$$

$$xy = 8. \quad (3)$$

Add  $2xy = 16$  to (1) and substitute  $z = 14 - (x + y)$  in the resulting equation. Solve first for  $x + y$  and then for  $x$  and  $y$ .

**220. Graphic Solution of Simultaneous Equations Involving Quadratics.**—Solve graphically the system,

$$x^2 + y^2 = 25.$$

$$x - y = -1.$$



Constructing the graphs, we find the first to be a circle, and the second to be a straight line.

The straight line intersects the circle in two points,  $(-4, -3)$  and  $(3, 4)$ . Hence, there are two solutions,

$$x = +3, y = +4 \text{ and } x = -4, y = -3.$$

The coordinates of the intersections satisfy both equations. The graph is shown in Fig. 64.

Solve graphically the system,

$$9x^2 + 25y^2 = 225.$$

$$y = 2.$$

The first equation represents an ellipse and the second is the equation of a straight line parallel to the  $X$ -axis. The points of intersection are

$$x = 3.7, y = 2 \text{ and } x = -3.7, y = 2.$$

These roots are real and unequal.

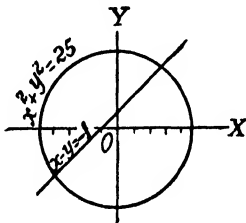

FIG. 64.

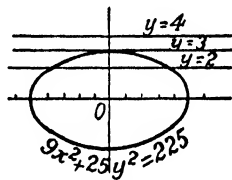

FIG. 65.

If the equation of the line was

$$y = 3,$$

the equation would have two real roots,  $x = 0, y = 3$  and  $x = 0, y = 3$ .

If the equation of the line was  $y = 4$ , the graphs would not intersect and the roots would be imaginary.

A system of two independent simultaneous equations in  $x$  and  $y$ , one linear and the other quadratic, has two roots.

The roots are real and equal if the graphs are tangent to each other, real and unequal if the graphs intersect, and imaginary if the graphs do not intersect; that is, if they have no points in common.

Solve graphically

$$4x^2 - 9y^2 = 36.$$

$$x^2 + y^2 = 25.$$

$$x = 4.5, \quad 4.5, \quad -4.5, \quad -4.5.$$

$$y = 2.2, \quad -2.2, \quad -2.2, \quad 2.2.$$

For the equation,

$$\begin{aligned}x^2 + y^2 &= 9, \\x &= 3, \quad 3, \quad -3, \quad -3. \\y &= 0, \quad 0, \quad 0, \quad 0.\end{aligned}$$

A system of two independent simultaneous equations of second degree in  $x$  and  $y$  has four roots.

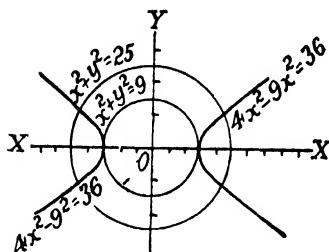

FIG. 66.

An intersection of the graphs represents a real root, and a point of tangency represents a pair of equal real roots.

If there are less than four real roots, the remaining roots are imaginary.

**221.** In many cases, the graphical method of solving two simultaneous quadratic equations is the only practical method to use. The graph of each quadratic equation is drawn according to the methods given in the previous articles (196 to 210) and their intersections determined. Some of the graphs previously made are used in the illustrative examples which follow.

**EXAMPLE 2.**—Solve the simultaneous equations,

$$y^2 = x \text{ and} \quad (1)$$

$$5(x - 4)^2 = 9 - y. \quad (2)$$

Beginning with (2) which is a parabola of the form,

$$y_1 + k = a(x + h)^2,$$

where

$$a = -5, k = -9, h = -4 \text{ (Art. 172).}$$

The  $y = x^2$  graph can be used but must be inverted since  $a$  is negative. The origin is located at  $(h, k)$  or  $(-4, -9)$  and the proportional dividers set to a 5 to 1 ratio to transfer the ordinates from the  $y = x^2$  graph.

The standard graph  $x = y^2$  is next used with the vertex at the origin and the curve extending to the right. The axis of symmetry will be the  $X$ -axis. The intersections of the graphs give the  $x$  and  $y$  values which satisfy the two equations. See Fig. 67.

**EXAMPLE 2.**—Solve the simultaneous equations,

$$x^2 - 4xy + y^2 + 4\sqrt{2}x - 2\sqrt{2}y + 11 = 0 \text{ (Fig. 61) and}$$

$$5x^2 - 4xy + y^2 - 12x + 11 = 0 \text{ (Fig. 58).}$$

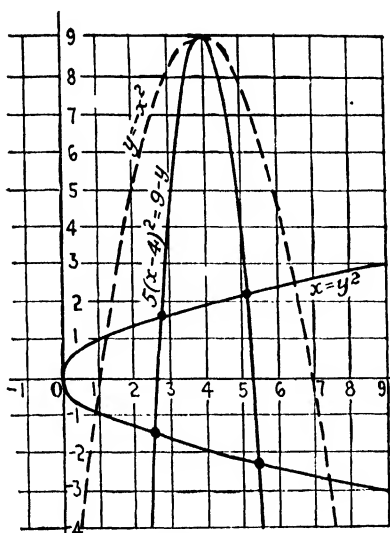

FIG. 67.

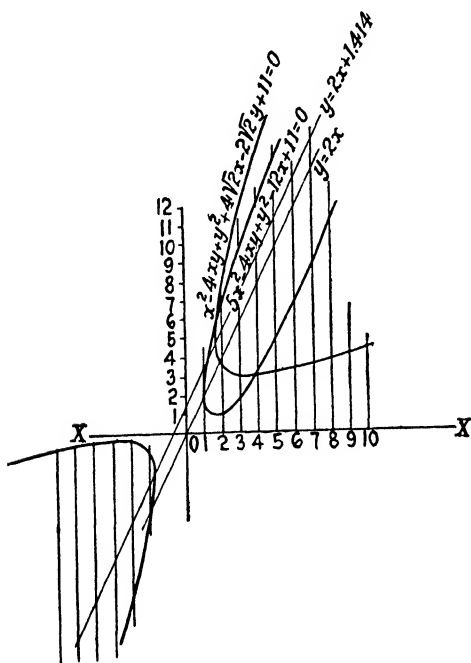

FIG. 68.

The graphs are constructed as shown in Art. 208. The values of the unknowns which satisfy both equations are determined by the points of intersections of the graphs. See Fig. 68.

EXAMPLE 3.—Solve the simultaneous equations,

$$y^2 - 2xy + x^2 - 2x - 3 = 0 \text{ (Fig. 57) and}$$

$$2x^2 + 4xy + 4y^2 - 4x - 12 = 0 \text{ (Fig. 59).}$$

The graphs are constructed as shown in Art. 208. The intersections of the graphs determine the values of the unknowns which satisfy the equations.

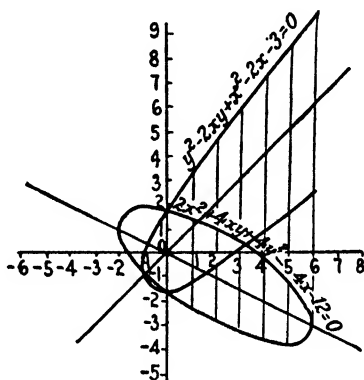

FIG. 69.

### 222. Simultaneous Quadratic Equations with Irrational Roots.

In Art. 195, a method was given for correcting the roots found by graphs of quadratic equations in one unknown. The same method may be used for simultaneous quadratic equations in two unknowns.

EXAMPLE.—Find a close approximation of the  $x$  and  $y$  values which satisfy

$$x^2 + y^2 - 5\sqrt{2}x - 5\sqrt{2}y = 0. \quad (1)$$

$$xy - 2x + y = 8. \quad (2)$$

The graphs of each equation are made according to methods previously described in Arts. 205 and 207 and are shown in Fig. 70. The correction method will be applied to point of intersection  $P(x, y)$  only. The other point may be taken by the reader as an exercise. From an inspection of the graph for  $P(x, y)$ ,

$$x = 8.5 \text{ approximately.}$$

$$y = 2.6 \text{ approximately.}$$

$$\text{Let } x = 8.5 + h \quad (3)$$

$$\text{and } y = 2.6 + k. \quad (4)$$

Substitute (3) and (4) in (1); then

$$72.25 + 17h + h^2 + 6.76 + 5.2k + k^2 - 60.1 - 7.07h - 18.38 - 7.07k = 0.$$

Discard the second-degree terms in  $h$  and  $k$  because they are small enough to neglect. Collecting similar terms,

$$9.93h - 1.87k + .53 = 0. \tag{5}$$

In the same manner, substitute (3) and (4) in (2), which gives

$$22.10 + 2.6h + 8.5k + hk - 17 - 2h + 2.6 + k = 8.$$

Discard the  $hk$  term and collect similar terms. Then

$$.6h + 9.5k - .3 = 0. \tag{6}$$

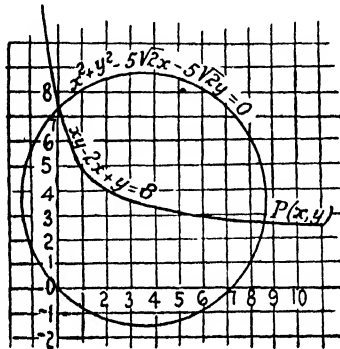

FIG. 70.

Solving (5) and (6) as simultaneous linear equations in  $h$  and  $k$ ,

$$9.93h - 1.87k + .53 = 0. \tag{5}$$

$$.6h + 9.5k - .3 = 0. \tag{6}$$

Multiplying (5) by .6 and (6) by 9.93,

$$5.958h - 1.122k + .318 = 0. \tag{7}$$

$$5.958h + 94.335k - 2.979 = 0. \tag{8}$$

Subtracting (7) from (8),

$$95.457k - 3.297 = 0.$$

$$k = .0346.$$

Substitute  $k = .0346$  in (6). Then

$$h = -.047.$$

Substituting in (3) and (4),

$$x = 8.5 + h = 8.5 - .047 = 8.453 \text{ approximately.}$$

$$y = 2.6 + k = 2.6 + .0346 = 2.6346 \text{ approximately}$$

In case greater accuracy of the roots is required, this process may be repeated by putting

$$x = 8.453 + h, \text{ and } y = 2.6346 + k,$$

and continuing as before.

## CHAPTER VIII

### FRACTIONS. FRACTIONAL EQUATIONS. IRRATIONAL EQUATIONS

#### FRACTIONS

**223. Operations with Fractions.**—In addition or subtraction of fractions, first reduce them all to a common denominator and place the sum (or difference) of the numerators over the common denominator.

In subtraction of a fraction, when it is preceded by a minus sign, change all the signs in the numerator when combining with the other terms. The sign belongs to the fraction as a whole and not to either the numerator or denominator. Thus, in  $-\frac{x}{2a}$  the sign of the fraction is minus while the signs of  $x$  and  $2a$  are both positive.

To change signs of either numerator or denominator of a fraction, the signs of all the terms must be changed.

Never cancel single terms in numerator or denominator of a fraction where either is a polynomial. In

$$\frac{a + b + b^2}{b}$$

the  $bs$  in the numerator and denominator cannot be cancelled. Only factors common to all the terms in both the numerator and denominator can be cancelled, which does not change the value of the fraction. In the expression,

$$\frac{ab + b^2}{ab},$$

the  $b$  is common to all the terms and may be cancelled, giving

$$\frac{a + b}{a}.$$

Fractions should always be reduced to the simplest form in which the numerator and denominator have no common factors.

To reduce a fraction to its lowest terms, resolve the numerator and denominator into their factors and cancel those factors common to both.

The numerator and denominator of a fraction may be multiplied by the same number or divided by the same number (not zero), without changing the value of the fraction.

#### 224. Elementary Forms.

$$\frac{a}{b} + \frac{c}{b} = \frac{a + c}{b}.$$

$$\frac{a}{b} - \frac{c}{b} = \frac{a - c}{b}.$$

$$a + \frac{b}{c} = \frac{a}{1} + \frac{b}{c} = \frac{ac + b}{c}.$$

$$\frac{a}{b} \times \frac{c}{d} = \frac{ac}{bd}.$$

$$\frac{a}{b} \div \frac{c}{d} = \frac{a}{b} \times \frac{d}{c} = \frac{ad}{bc}.$$

$$\frac{a}{b} = \frac{na}{nb} \quad (n \text{ not zero})$$

$$\frac{a}{b} = \frac{\frac{a}{n}}{\frac{b}{n}} \quad (n \text{ not zero}).$$

$$\frac{a}{b} + \frac{c}{d} = \frac{ad + bc}{bd}.$$

$$-\frac{a}{b} = \frac{-a}{b} = \frac{a}{-b}.$$

$$-\frac{a + b}{c} = \frac{-a - b}{c}.$$

$$-\frac{a - b}{c} = \frac{-(a - b)}{c} = \frac{-a + b}{c}.$$

#### FRACTIONAL EQUATIONS

**225. Fractional Equations.**—An equation containing a fraction with an unknown in a denominator of any of the terms is called a *fractional equation*. The usual method of procedure is

to simplify first, and then to multiply each term by the lowest common multiple (Art. 111) of the denominators to eliminate the denominators. The lowest common multiple, or any multiplier containing an unknown, as  $x$ , may introduce new roots not possessed by the given equation. These roots are called *extraneous roots* and may be found by equating the multiplier to zero and solving for  $x$ . In order to make sure that extraneous roots are not introduced, the roots should be substituted in the given equation for verification. Those roots which do not satisfy the given equation should be discarded. A few illustrative examples of fractional equations will be given.

EXAMPLE 1.—Find the value of  $x$  in

$$\frac{4}{5x} - 16 = \frac{2}{5x} + 6 = 4\frac{1}{5}.$$

Simplifying,

$$\frac{1 - 20x}{30x} - \frac{1 + 15x}{150x} = \frac{5}{6}.$$

Multiplying each term by 150 $x$ , the lowest common multiple of the denominators,

$$\begin{aligned} 5 - 100x - 1 - 15x &= 125x. \\ 240x &= 4. \\ x &= \frac{1}{60}. \end{aligned}$$

$\frac{1}{60}$  satisfies the original equation.

EXAMPLE 2.—Find the value of  $x$  in

$$\frac{3}{x^2 - 25} + \frac{1}{x + 5} = \frac{2}{5 - x}.$$

The term  $\frac{2}{5 - x}$  can be changed to  $-\frac{2}{x - 5}$  without changing its value. Multiplying all terms by the lowest common multiple ( $x^2 - 25$ ) of the denominators,

$$\frac{3(x^2 - 25)}{x^2 - 25} + \frac{x^2 - 25}{x + 5} = -\frac{2(x^2 - 25)}{x - 5}.$$

Reducing,

$$\begin{aligned} 3 + x - 5 &= -2(x + 5) = -2x - 10. \\ 3x &= -8. \\ x &= -\frac{8}{3}. \end{aligned}$$

$-\frac{8}{3}$  satisfies the original equation.

EXAMPLE 3.—Find the value of  $x$  in

$$2 + \frac{9}{6 + x} = x.$$



Multiplying by  $6 + x$ , the L.C.M. of the denominators,

$$12 + 2x + 9 = 6x + x^2.$$

$$x^2 + 4x - 21 = 0.$$

$$x = 3 \text{ or } -7.$$

Both  $x = 3$  and  $x = -7$ , when substituted in  $2 + \frac{9}{6+x} = x$ , satisfy the equation.

EXAMPLE 4.—Find the value of  $x$  in

$$1 + \frac{1}{x-1} = \frac{x^2}{x-1} - 6.$$

Multiplying all terms by  $x - 1$ ,

$$x - 1 + 1 = x^2 - 6x + 6.$$

$$x^2 - 7x + 6 = 0.$$

$$x = 6 \text{ or } 1.$$

The substitution of  $x = 6$  satisfies the given equation, but the substitution of  $x = 1$  does not. It is, therefore, an extraneous root and should be discarded. It was introduced by the multiplier,  $x - 1$ . If the multiplier is equated to zero, then  $x - 1 = 0$  or  $x = 1$ .

**226. Extraneous Roots Avoided.**—By combining terms in some fractional equations, a reduction can be made to an integral (Art. 129) equation without the use of a multiplier. Example 4 in the previous article can be solved in this manner.

$$1 + \frac{1}{x-1} = \frac{x^2}{x-1} - 6.$$

Uniting terms,

$$\frac{x^2 - 1}{x - 1} = 7.$$

$$x + 1 = 7.$$

$$x = 6$$

EXAMPLE 2.—Find the value of  $x$  in

$$\frac{2x^2}{x-2} = \frac{3x+2}{x-2} + \frac{5x+9}{3}.$$

Uniting terms,

$$\frac{2x^2 - 3x - 2}{x - 2} = \frac{5x + 9}{3}.$$

Reducing,

$$2x + 1 = \frac{5x + 9}{3}.$$

$$6x + 3 = 5x + 9.$$

$$x = 6.$$

If this equation is multiplied by  $3(x - 2)$ , the L.C.M. of the denominators, the root  $x = 2$  will be introduced which will not satisfy the equation.

**227. Fractional equations with two or more monomial denominators** can be advantageously solved by removing the monomial denominators first, then simplifying, and then removing the remaining denominators as shown in the previous article (225).

EXAMPLE.—Find the value of  $x$  in

$$\frac{9x + 5}{14} + \frac{8x - 7}{6x + 2} = \frac{36x + 15}{56} + \frac{10\frac{1}{2}}{14}.$$

Eliminate the monomial denominators by multiplying through by 56, the L.C.M. of the monomial denominators.

$$36x + 20 + \frac{56(8x - 7)}{6x + 2} = 36x + 15 + 41.$$

Simplifying,

$$\frac{7(8x - 7)}{3x + 1} = 9.$$

Multiplying through by  $3x + 1$ ,

$$\begin{aligned} 56x - 49 &= 27x + 9. \\ \cdot 29x &= 58. \\ x &= 2. \end{aligned}$$

**228. Reducing fractions in equations containing terms like**

$$\frac{x + 3}{x - 2} \text{ and } \frac{x - 1}{x - 7}$$

in pairs connected by minus signs can be readily solved by uniting the terms of each member of the equation. The fractions can be arranged to meet this condition by transposing, if necessary, one fraction in each member.

EXAMPLE.

$$\frac{x - 1}{x - 2} + \frac{x - 6}{x - 7} = \frac{x - 5}{x - 6} + \frac{x - 2}{x - 3}.$$

Transposing,

$$\frac{x - 1}{x - 2} - \frac{x - 2}{x - 3} = \frac{x - 5}{x - 6} - \frac{x - 6}{x - 7}.$$

Uniting terms,

$$\frac{-1}{x^2 - 5x + 6} = \frac{-1}{x^2 - 13x + 42}.$$

Since the fractions are equal and their numerators identical, then the denominators must be equal.

$$\begin{aligned} x^2 - 5x + 6 &= x^2 - 13x + 42. \\ x &= 4\frac{1}{2}. \end{aligned}$$

This example illustrates why it is sometimes advisable to defer the clearing of fractions.

IRRATIONAL EQUATIONS

**229.** Irrational equations are transformed into rational equations by raising both members to equal powers. The index used is indicated by the greatest index among the radicals. If only one radical is present in the equation, it is advisable to transpose all the rational terms to one side of the equation and leave the radical term on the other before raising the members to a power.

EXAMPLE.

$$\begin{aligned} 1 + \sqrt{x} &= 5. \\ \sqrt{x} &= 4. \\ x &= 16. \end{aligned}$$

If the square root is taken of each member of the equation,

$$x - 2 = 4,$$

then

$$\pm \sqrt{x - 2} = 2,$$

or

$$\sqrt{x - 2} = 2 \quad \text{and} \quad \sqrt{x - 2} = -2.$$

When one is taking a square root, both signs must always be considered. If one has  $x - 2 = 4$ , it is wrong to deduce

$$\sqrt{x - 2} = 2$$

and neglect the case,

$$-\sqrt{x - 2} = 2.$$

Both cases,  $\pm \sqrt{x - 2} = 2$ , must be considered. Notice that to indicate *both* cases,  $\pm \sqrt{x - 2} = 2$  is written. If  $\sqrt{x - 2} = 2$  is written, this represents *only one* of the two cases. Now when a radical equation is given us to solve, we are not taking the square root. It has been taken and we are given only one case, as  $\sqrt{x - 2} = x + 17$ , or we are given both cases,  $\pm \sqrt{x - 2} = x + 17$ .

If given an equation like

$$\sqrt{a + x} + \sqrt{a - x} = \sqrt{2x},$$

the positive values only of the radicals are considered unless given

$$\pm \sqrt{a + x} \pm \sqrt{a - x} = \pm \sqrt{2x}.$$

If a term is given like  $-\sqrt{a - x}$ , the radical is still considered as being positive, or  $-(+\sqrt{a - x})$ . Solving the example just given,

$$\sqrt{a + x} + \sqrt{a - x} = \sqrt{2x}.$$

Squaring,

$$a + x + 2\sqrt{a^2 - x^2} + a - x = 2x.$$

$$\sqrt{a^2 - x^2} = x - a.$$

Squaring again,

$$a^2 - x^2 = x^2 - 2ax + a^2.$$

$$2x^2 - 2ax = 0.$$

$$2x(x - a) = 0.$$

$$x = 0 \text{ or } a.$$

The substitution of  $x = a$  satisfies the given equation but  $x = 0$  does not; for

$$\sqrt{a+0} + \sqrt{a-0} \neq \sqrt{2 \times 0}.$$

If, however, we should take  $\sqrt{a-0}$  as meaning  $-\sqrt{a}$ , the equation would be satisfied. The understanding is that  $\sqrt{a-x}$  means  $+\sqrt{a-x}$ , and hence, the root  $x = 0$  must be thrown out.

When members of a radical equation are squared, it is equivalent to multiplying by an expression containing an unknown which may introduce extraneous roots (Arts. 225 and 129).

EXAMPLE.—Find the roots of

$$\sqrt{x-2} = x-4.$$

Squaring,

$$x-2 = x^2 - 8x + 16.$$

Rearranging,

$$x^2 - 9x = -18.$$

Completing the square and solving for  $x$ ,

$$x = 6, \text{ or } 3.$$

The root  $x = 6$  when substituted in the given equation, satisfies it but  $x = 3$  does not. If, however, the negative value of the radical, or  $-\sqrt{x-2}$ , is considered, then  $x = 3$  does satisfy the equation. Since only the positive value of the radical is stated in the problem,  $x = 3$  is an extraneous root introduced when the radical was squared and it should be discarded.

If an irrational equation has a denominator in either or both members, simplify or rationalize the denominator first before raising to a power.

EXAMPLE.—Solve

$$\frac{\sqrt{2} + \sqrt{x}}{\sqrt{2} - \sqrt{x}} = \frac{2\sqrt{x}}{\sqrt{2} + \sqrt{x}} - \frac{(x+2)^2}{2(x-2)}.$$

Rationalizing the denominators,

$$\frac{(\sqrt{2} + \sqrt{x})^2}{(\sqrt{2} - \sqrt{x})(\sqrt{2} + \sqrt{x})} = \frac{2\sqrt{x}(\sqrt{2} - \sqrt{x})}{(\sqrt{2} + \sqrt{x})(\sqrt{2} - \sqrt{x})} - \frac{(x + 2)^2}{2(x - 2)}$$

$$\frac{2 + 2\sqrt{2x} + x}{2 - x} = \frac{2\sqrt{2x} - 2x}{2 - x} + \frac{x^2 + 4x + 4}{2(2 - x)}$$

Multiplying this by  $2(2 - x)$ ,

$$4 + 4\sqrt{2x} + 2x = 4\sqrt{2x} - 4x + x^2 + 4x + 4.$$

$$x^2 - 2x = 0.$$

$$x(x - 2) = 0.$$

$$x = 0, \text{ or } x = 2.$$

Verifying  $x = 0$ ,

$$\frac{\sqrt{2} + 0}{\sqrt{2} - 0} = \frac{0}{\sqrt{2} + 0} - \frac{(0 - 2)^2}{2(0 - 2)}$$

$$1 = 0 + 1.$$

$x = 0$  is a root.

Verifying for  $x = 2$ ,

$$\frac{\sqrt{2} + \sqrt{2}}{\sqrt{2} - \sqrt{2}} = \frac{2\sqrt{2}}{\sqrt{2} + \sqrt{2}} - \frac{(2 + 2)^2}{2(2 - 2)}$$

$$\infty = 1 - \infty.$$

$x = 2$  is not a root.

EXAMPLE.—Solve

$$\frac{\sqrt{2x} + 2}{\sqrt{2x} - 2} = \frac{\sqrt{x + 1} + 3}{\sqrt{x + 1} - 3}$$

Multiply both members of the equation by  $(\sqrt{2x} - 2)(\sqrt{x + 1} - 3)$ , which is the lowest common multiple of the denominators.

$$(\sqrt{2x} + 2)(\sqrt{x + 1} - 3) = (\sqrt{x + 1} + 3)(\sqrt{2x} - 2).$$

$$\sqrt{2x^2 + 2x} + 2\sqrt{x + 1} - 3\sqrt{2x} - 6 = \sqrt{2x^2 + 2x} - 2\sqrt{x + 1} + 3\sqrt{2x} - 6$$

Simplifying,

$$6\sqrt{2x} = 4\sqrt{x + 1}.$$

$$3\sqrt{2x} = 2\sqrt{x + 1}.$$

Squaring,

$$18x = 4x + 4.$$

$$x = \frac{4}{7}.$$

### 230. Some Special Devices.

EXAMPLE.—Solve

$$2\sqrt{x^2 - 9x + 18} - \sqrt{x^2 - 4x - 12} = x - 6.$$

Factoring the radical expressions,

$$2\sqrt{(x - 3)(x - 6)} - \sqrt{(x + 2)(x - 6)} = x - 6,$$

or

$$2\sqrt{x - 3}\sqrt{x - 6} - \sqrt{x + 2}\sqrt{x - 6} = \sqrt{x - 6}\sqrt{x - 6}.$$

Then

$$\sqrt{x-6}(2\sqrt{x-3} - \sqrt{x+2} - \sqrt{x-6}) = 0.$$

Equating the factor  $\sqrt{x-6}$  to zero gives one of the roots which is  $x = 6$  (see Art. 129).

Also,

$$2\sqrt{x-3} - \sqrt{x+2} = \sqrt{x-6}.$$

Squaring,

$$\begin{aligned} 4x - 12 - 4\sqrt{(x-3)(x+2)} + x + 2 &= x - 6. \\ -4\sqrt{x^2 - x - 6} &= 4 - 4x. \\ \sqrt{x^2 - x - 6} &= x - 1. \end{aligned}$$

Squaring,

$$\begin{aligned} x^2 - x - 6 &= x^2 - 2x + 1. \\ x &= 7. \end{aligned}$$

Verifying, both  $x = 6$  and  $x = 7$  satisfy the given equation.

EXAMPLE.—Solve

$$\frac{x-7}{\sqrt{x-3}-2} + \frac{x-5}{\sqrt{x-4}-1} = 4\sqrt{x-3}.$$

Change numerator,  $x-7$ , to  $(x-3)-4$ , and  $x-5$  to  $(x-4)-1$ .

Then

$$\frac{(x-3)-4}{\sqrt{x-3}-2} + \frac{(x-4)-1}{\sqrt{x-4}-1} = 4\sqrt{x-3}.$$

Simplifying,

$$\sqrt{x-3} + 2 + \sqrt{x-4} + 1 = 4\sqrt{x-3}.$$

Collecting common terms,

$$\sqrt{x-4} = 3\sqrt{x-3} - 3 = 3(\sqrt{x-3} - 1).$$

Squaring,

$$\begin{aligned} x-4 &= 9x - 27 - 18\sqrt{x-3} + 9. \\ 18\sqrt{x-3} &= 8x - 14. \\ 9\sqrt{x-3} &= 4x - 7. \end{aligned}$$

Squaring,

$$\begin{aligned} 81(x-3) &= 16x^2 - 56x + 49. \\ 81x - 243 &= 16x^2 - 56x + 49. \\ 16x^2 - 137x + 292 &= 0. \\ x &= \frac{13}{8}, \text{ and } 4. \end{aligned}$$

Both roots satisfy the given equation.

CHAPTER IX  
CUBIC FUNCTIONS

**231. Graphical Cubic Functions.**—When the function  $y = x^3$  is plotted, the resulting graph is a curve of the type called the cubic parabola. If  $x$  is positive,  $y$  is positive, and if  $x$  is negative,  $y$  is negative, and the graph takes a form similar to that shown in Fig. 71. In the case of the function  $y = -x^3$ , however, positive values of  $x$  give positive values to  $x^3$ , and the corresponding values of  $y$  are consequently negative. Also negative values of  $x$  make  $x^3$  negative and  $y$  positive. The graph of  $y = -x^3$  is shown in Fig. 72 and comparison with Fig. 71 will at once disclose

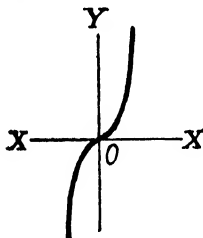

FIG. 71.

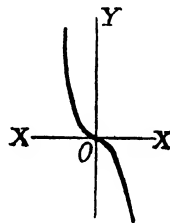

FIG. 72.

the effect of the minus sign before the  $x^3$ . Note that for a given value of  $x$  the functions have the same absolute value but differ in sign.

It is advisable to retain an accurately plotted graph of both  $y = x^3$  and  $y = -x^3$  so that they may be readily available for rapid graphical work.

**232. The Function  $y = ax^3$ .**

This graph can be readily made from a graph of  $y = x^3$  by stretching or contracting the ordinate scale in the ratio of  $a$  to 1, according as  $a$  is greater or less than 1. The method has already been explained and its application observed in Art. 170 where the graph of  $y = ax^2$  was obtained from the graph of  $y = x^2$ .

The proportional divider is very convenient and its use affords a rapid means of obtaining the ordinate scale for  $y = ax^3$  from the ordinate scale of  $y = x^3$ . If  $a$  is negative, the signs of the ordinates are reversed. The effect of the sign of  $a$  on the nature of the graph is shown in Fig. 73, where  $a$  is positive ( $a > 0$ ), and in Fig. 74, where  $a$  is negative ( $a < 0$ ).

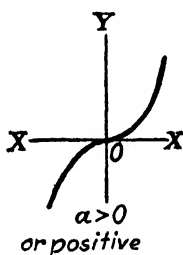

FIG. 73.

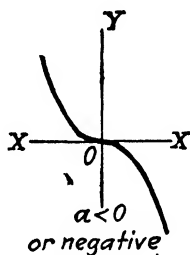

FIG. 74.

**233. The Function  $y = a(x - h)^3 + k$ .**—This function can be written in the form,

$$[59] \quad y - k = a(x - h)^3.$$

This equation represents the graph of  $y = ax^3$  with the origin shifted to the point  $(-h, -k)$  where the distance  $k$  is measured on the new ordinate scale.

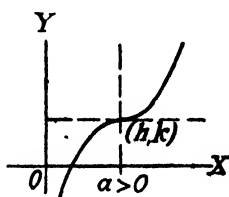

FIG. 75.

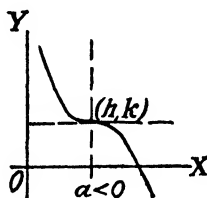

FIG. 76.

By drawing the graph of  $y = ax^3$  and locating a new origin at the point  $(-h, -k)$ , we have a graph of the function  $y - k = a(x - h)^3$  referred to the new axes.

**234. Addition of  $mx$  Term in the Cubic Equation.**—The addition of this term to  $x^3$  or to  $ax^3$  so that the function becomes  $y = x^3 + x$  or  $y = ax^3 + mx$  gives the graphs of the functions  $y = x^3$  and  $y = ax^3$  a shearing motion. The graph of  $y = x^3 + x$



can be quickly drawn from the graph of  $y = x^3$  by increasing or decreasing the value of  $y$  in  $y = x^3$  by an amount equal to  $x$ .

EXAMPLE.—Change the graph of  $y = x^3$  to represent  $y = x^3 - 3x$ .

Since the values of  $y$  or the ordinates of the curve,  $y = x^3 - 3x$ , are the same as the ordinates of the curve,  $y = x^3$ , when these are decreased by an amount equal to  $3x$ , we can graphically denote this subtraction in the following way:

On the graph of  $y = x^3$  (Fig. 77), draw a line  $AB$  with a slope of  $-3$ . If, now, we take any point  $P$  on the graph of  $y = x^3$  and lay off its ordinate  $y$ , using the divider, and then transfer this distance measuring from the line  $AB$  each time, as  $ST$  is measured, we have a means of subtracting the  $3x$  term from  $y = x^3$  and the result is a graph of  $y = x^3 - 3x$ .

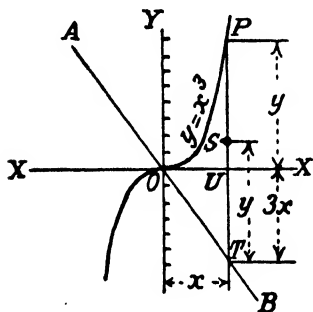

FIG. 77.

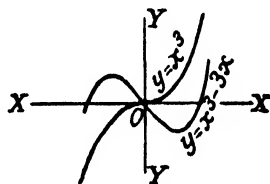

FIG. 78.

This new curve takes the form shown in Fig. 78.

The intersections of the curve with the  $X$ -axis give the roots of the equation

$$x^3 - 3x = 0.$$

The graph retains its original axes of coordinates.

The distortion of the curve which transforms its equation from  $y = x^3$  to  $y = x^3 - 3x$  is called a shear with respect to  $y = -3x$ .

235. The graph of

[60]

$$y = ax^3 + mx$$

has one of the following forms according to the signs of  $a$  and  $m$ :

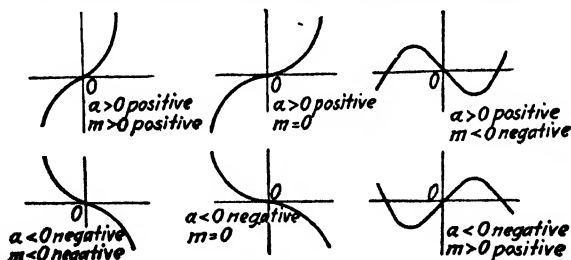

FIGS. 79 TO 84.

The curve represented by  $y = ax^3$  can readily be drawn from the graph of  $y = x^3$  as their ordinates have the ratio of  $a$  to 1 in all cases, and the proportional divider is very useful in making the transformation as explained in Art. 232, providing that  $a$  is not too large.

**236. The transposing constants  $h$  and  $k$**  which change the location of the origin to the point  $(h, k)$  when introduced into the equation,  $y = ax^3 + mx$ , by the substitution of  $x + h$  for  $x$ , and  $y + k$  for  $y$ , cause the equation to take the form,

$$y + k = a(x + h)^3 + m(x + h), \quad (1)$$

which becomes

$$y = ax^3 + 3ahx^2 + (3ah^2 + m)x + ah^3 + mh - k \quad (2)$$

when expanded. This is in the form of the general cubic equation,

$$[61] \quad y = ax^3 + bx^2 + cx + d,$$

in which, by comparison with (1),

$$b = 3ah, \quad c = 3ah^2 + m, \quad \text{and} \quad d = ah^3 + mh - k. \quad (3)$$

The values of  $a$  and  $b$  in any equation of the general form determine the value of  $h$ , for

$$[62] \quad h = \frac{b}{3a},$$

and the value of  $h$  being found,  $m$  is easily found, for

$$[63] \quad m = c - 3ah^2 = c - \frac{b^2}{3a}.$$

When the values of  $h$  and  $m$  are substituted in the last equation of (3),  $k$  may be found to be

$$[64] \quad k = \frac{bc}{3a} - \frac{2b^3}{27a^2} - d.$$

If we have the equation,  $y = ax^3 + mx$  [60], we can put it into the general form,  $y = ax^3 + bx^2 + cx + d$ , by moving the origin to the point  $(h, k)$  or in terms of  $a, b, c, d$ ,

$$\left( \frac{b}{3a}, \frac{bc}{3a} - \frac{2b^3}{27a^2} - d \right).$$

**237. To draw the graph of a cubic function**, we first put the equation in the standard form,

$$y = ax^3 + bx^2 + cx + d. \quad [61]$$

We next take the standard graph of  $y = x^3$  and put it into the

form,  $y = ax^3$ , and find the value of  $m$  which is given by [63] as

$$m = c - \frac{b^2}{3a}.$$

This enables us to shear the graph of  $y = ax^3$  and get the graph of  $y = ax^3 + mx$  [60]. Shifting the origin to the point  $(h, k)$  completes the transformation of the graph and it is now the graph of the equation,

$$y = ax^3 + bx^2 + cx + d.$$

Let  $AB$  in Fig. 85 be the graph of  $y = x^3$  and  $ADEB$  the graph after it has been changed to represent  $y = ax^3 + mx$  according to Arts. 234 and 235. Next shift the origin to the point  $(h, k)$  where  $h$  and  $k$  are determined from

$$h = \frac{b}{3a} \text{ and } k = \frac{bc}{3a} - \frac{2b^3}{27a^2} - d.$$

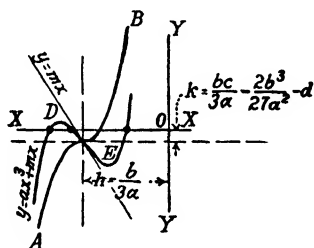

FIG. 85.

The curve, as drawn and referred to the origin just located, represents the function,

$$y = ax^3 + bx^2 + cx + d \text{ [61]}$$

which is the general form of a cubic function. A solution of any cubic equation in one unknown can now be found graphically. After approximate values of  $x$  have been found for which  $y = 0$ , substitution of these values in the general equation should be made and the method of Arts. 195 and 222 used to find more exact values if necessary.

In drawing the graph of a cubic, it is advisable to use for the  $Y$ -scale a unit which is about one-tenth of the length of the  $X$ -unit, so that greater values of  $y$  may be drawn on the sheet.

EXAMPLE 1.—Draw the graph of  $y = x^3 + 5x^2 - 14x + 3$ .

$$m = c - \frac{b^2}{3a} = -14 - \frac{25}{3} = -22\frac{1}{3}.$$

Starting with the  $y = x^3$  graph, draw the shear line through the origin with a slope of  $-22\frac{2}{3}$  to 1 as shown at  $AB$  (Fig. 86).

Next shear the graph with respect to the line  $AB$  by transferring the ordinates of  $y = x^3$  and measuring from  $AB$ .

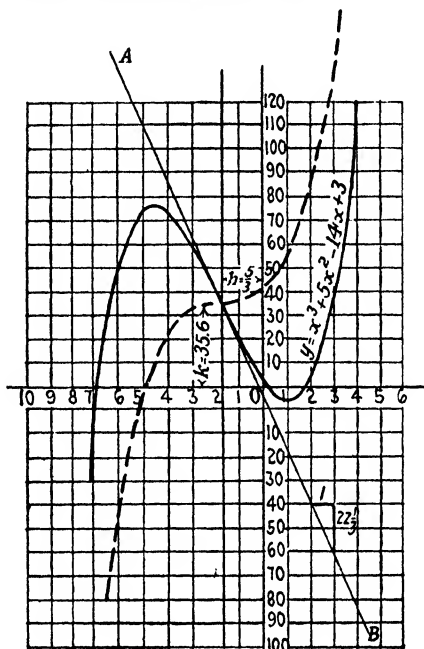

FIG. 86.

The origin is next translated to  $(h, k)$ .

$$h = \frac{b}{3a} = \frac{5}{3} \quad [62]$$

$$k = \frac{5(-14)}{3} - \frac{2 \times 125}{27} - 3 = -35.6. \quad [64]$$

With the origin located at  $(\frac{5}{3}, -35.6)$ , the graph represents

$$y = x^3 + 5x^2 - 14x + 3.$$

EXAMPLE 2.—Draw the graph of

$$y = 2x^3 - 15x^2 + 11.$$

$$m = c - \frac{b^2}{3a} = 0 - \frac{225}{6} = -37.5.$$

$$h = \frac{-15}{6} = -2.5.$$

$$k = 0 - \frac{2(-15)^3}{27 \times 4} - 11 = 51.5.$$

Starting with the graph of  $y = x^3$ , first multiply the ordinate scale by 2 to change the graph to represent  $y = 2x^3$ . Draw the shear line  $AB$  with a slope of  $-37.5$  to 1 measured on the new scale. Then shear  $y = 2x^3$  on the line  $AB$ . Translate the origin to  $(h, k)$  or to  $(-2.5, 51.5)$ , and the graph (Fig. 87) represents the equation,

$$y = 2x^3 - 15x^2 + 11.$$

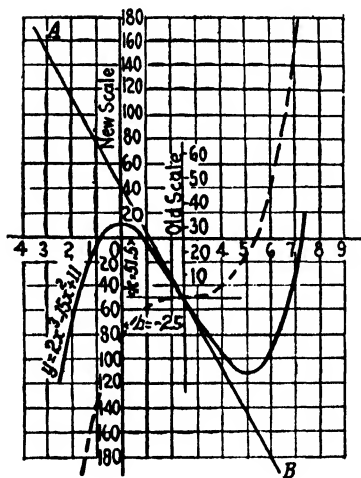

FIG. 87.

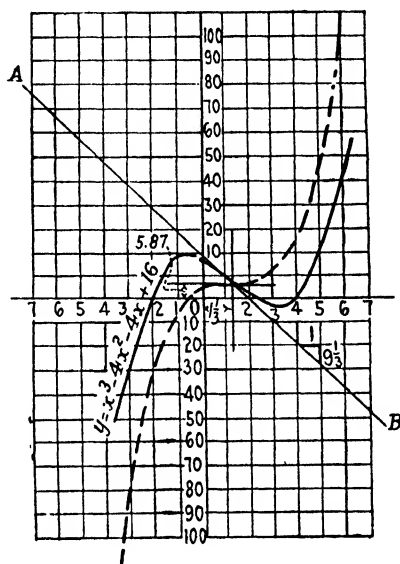

FIG. 88.

**238. Graphical solution of equations of the form,**

$$ax^3 + bx^2 + cx + d = 0.$$

The graph of  $y = ax^3 + bx^2 + cx + d$  is useful in solving equations in one unknown, as  $ax^3 + bx^2 + cx + d = 0$ , and we now come to the discussion of this very important method of graphical solution of equations of the forms,  $x^3 + bx^2 + cx + d = 0$  and  $ax^3 + bx^2 + cx + d = 0$ .

Assume that we desire first the roots of

$$x^3 + bx^2 + cx + d = 0.$$

The graph of  $y = x^3 + bx^2 + cx + d$  will represent all of the corresponding real values of  $x$  and of  $x^3 + bx^2 + cx + d$ ; and among them will be the values of  $x$  that make  $x^3 + bx^2 + cx + d$  equal to 0, that is, the roots of the equation,

$$x^3 + bx^2 + cx + d = 0.$$

EXAMPLE.—Find the roots of

$$x^3 - 4x^2 - 4x + 16 = 0.$$

Draw the graph of  $y = x^3 - 4x^2 - 4x + 16$ , using the graph of  $y = x^2$ .

$$m = -9\frac{1}{3}, h = -1\frac{1}{3}, \text{ and } k = -5.87.$$

The intersections of the graph and the X-axis (Fig. 88) give the values of  $x$  which make  $x^3 - 4x^2 - 4x + 16$  equal to 0, or the roots of the equation,  $x^3 - 4x^2 - 4x + 16 = 0$ . They are

$$x = 2, x = 4, \text{ and } x = -2.$$

**239. Pairs of simultaneous equations in  $x$  and  $y$** , one of which is of the form,  $y = ax^3 + bx^2 + cx + d$ , may be solved by drawing the graphs of each and locating the intersections of the graphs.

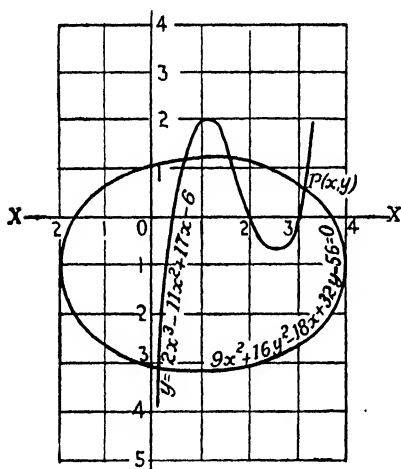

FIG. 89.

EXAMPLE.—Find the  $x$  and  $y$  values which satisfy

$$9x^2 + 16y^2 - 18x + 32y - 56 = 0.$$

$$y = 2x^3 - 11x^2 + 17x - 6.$$

The graphs are made by the methods given in Arts. 205 and 237. Care must be taken to make sure that the ordinates are to the same scale in both cases. The graphs may also be made separately on transparent paper; then by placing one sheet upon the other with axes coinciding,

the intersections can be located. The  $x$  and  $y$  values which satisfy the given equations from Fig. 89 are  $(.2, -3.2)$ ,  $(.7, 1.3)$ ,  $(1.6, 1.3)$ , and  $(3.2, .6)$ .

**240. Simultaneous equations with irrational roots** similar to those of the previous article on graphical solutions may be solved with greater precision by the methods given in Art. 222. The values for  $P(x, y)$  in the previous article will be solved.

$$9x^2 + 16y^2 - 18x + 32y - 56 = 0. \quad (1)$$

$$y = 2x^3 - 11x^2 + 17x - 6. \quad (2)$$

From Fig. 89 of the graphs,  $P(x, y)$  is  $(3.2, .6)$ .

$$\text{Let } x = 3.2 + h \text{ and } y = .6 + k. \quad (3)$$

Substituting in (1) and disregarding second-degree terms in  $h$  and  $k$ ,  
 $92.16 + 57.6h + 5.76 + 19.2k - 57.6 - 18h + 19.2 + 32k - 56 = 0$ .

Simplifying,

$$39.6h + 51.2k + 3.52 = 0. \quad (4)$$

In the same manner, substitute (3) in (2) and discard second- and third-degree terms in  $h$  and  $k$ ; then

$$.6 + k = 65.54 + 61.44h - 112.64 - 70.4h + 54.4 + 17h - 6.$$

Simplifying,

$$k = 8.04h + .7. \quad (5)$$

Substituting (5) in (4),

$$\begin{aligned} 39.6h + 411.65h + 35.84 + 3.52 &= 0. \\ 451.25h &= -39.36. \\ h &= -.087. \end{aligned}$$

Substituting in (5),

$$k = .6995 - .7 = -.0005.$$

Substituting  $h$  and  $k$  values in (3),

$$x = 3.113. \quad y = .5995.$$

This method may be repeated in the same manner with the corrected  $x$  and  $y$  values if still greater precision is desired.

**241. Another method** of graphically solving the cubic  $x^3 + bx^2 + cx + d = 0$  is to assume the two simultaneous equations,

$$\begin{aligned} y &= x^3 \text{ and} \\ y &= -cx - d \text{ (if the } x^2 \text{ term is absent).} \end{aligned}$$

We know that the ordinates for the points of intersection of the two curves are the same, or, stating the same thing in a different way, the abscissae of the points of intersection denote those values of  $x$  which make both functions have the same value. Therefore,

$$x^3 = -cx - d, \text{ or } x^3 + cx + d = 0.$$

We can, therefore, take the standard graph of  $y = x^3$  and draw the straight line,  $y = -cx - d$ , and from the points of intersection, quickly determine the different values of  $x$  which satisfy the equation,  $x^3 + cx + d = 0$ .

In the event of the  $x^2$  term being present, we have

$$\begin{aligned} y &= x^3 \text{ and} \\ y &= -bx^2 - cx - d \end{aligned}$$

for our simultaneous equations, and we can easily graph the quadratic with respect to the same axes as the cubic and note the intersections of the two curves.

Very difficult problems may be readily solved by the use of these methods, and if there is no solution, the graphs will disclose the fact at once.

**242.** Still another convenient method to use is to eliminate the  $x^2$  term by shifting the origin.

This is done by substituting

$$x - \frac{a}{3} \text{ for } x, \text{ or making } h = \frac{a}{3}.$$

Since we have started with the graph of  $y = x^3$ , we shift the origin to the point  $(-h, 0)$ , or  $(-\frac{a}{3}, 0)$ .

We, therefore, take the standard graph,  $y = x^3$ , shift the origin, and draw the straight line to represent  $y = -cx - d$ , noting the intersections of the two graphs.

**243.** It is also convenient to know the slope of the curve, or the rate of change of the function with respect to the variable in the general equation,

$$y = ax^3 + bx^2 + cx + d.$$

This slope is, from methods of the calculus, found to be for any point  $P_1(x_1, y_1)$ ,

$$m = 3x_1^2 + 2bx_1 + c.$$

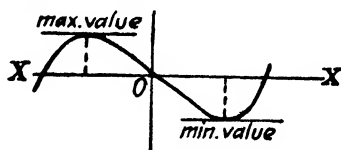

FIG. 90.

When the graph of any function is drawn, it is very easy to determine the maximum and minimum values. These occur at points where the slope of the curve is zero, or where the tangent to the curve is parallel to the X-axis. To find the points at which a maximum or a minimum occurs, it is only necessary to place the expression for  $m$ , given above, equal to zero and solve for the values of  $x_1$ . The values found for  $x_1$  denote those values of  $x$  for which  $y$  has a maximum or a minimum.

**PROBLEM.**—A cylindrical vat is to be placed on end beneath the rafters in an attic. The clearance space between the rafters is shown



in Fig. 91. What dimensions will give the maximum capacity of the vat?

Let  $x$  = the height of vat.

$z$  = the radius of base.

$y$  = the volume of vat.

Then  $y = \pi xz^2$ .

From similar triangles,

$$10 - x : z = 10 : 5.$$

$$\therefore z = \frac{10 - x}{2}.$$

Then

$$y = \pi x \left( \frac{10 - x}{2} \right)^2 = \frac{\pi}{4} (x^3 - 20x^2 + 100x),$$

or

$$y = .7854x^3 - 15.7x^2 + 78.54x.$$

From the above equation,

$$a = .7854, b = -15.7, \text{ and } c = 78.54,$$

which substituted in

$$m = 3a(x_1)^2 + 2b(x_1) + 78.54$$

gives

$$\begin{aligned} m &= 3 \times .7854x_1^2 + 2(-15.7)x_1 + 78.54. \\ &= 2.356(x_1)^2 - 31.4(x_1) + 78.54. \end{aligned}$$

In order to find a maximum,  $m$  is equated to zero, or

$$2.356(x_1)^2 - 31.4(x_1) + 78.54 = 0.$$

Using formula [6],

$$\begin{aligned} x_1 &= \frac{-b \pm \sqrt{b^2 - 4ac}}{2a} \\ &= \frac{+31.4 \pm \sqrt{(31.4)^2 - 4 \times 2.36 \times 78.54}}{2 \times 2.36} \\ &= 3.32 \text{ or } 10. \end{aligned}$$

$x$  cannot be 10 feet high but it can be 3.32 feet. From the above equation,

$$z = \frac{10 - x}{2} = \frac{10 - 3.32}{2} = 3.34.$$

The dimensions of the vat, then, are 3.32 feet high and 3.34 feet radius of base. The maximum capacity, then, from

$$y = \pi xz^2$$

is  $y = 3.1416 \times 3.32 \times (3.34)^2 = 114.7$  cubic feet.



FIG. 91.

The graph of

$$y = .7854x^3 - 15.7x^2 + 78.54x$$

which is drawn from  $y = x^3$  and sheared as in Art. 236 plainly shows how

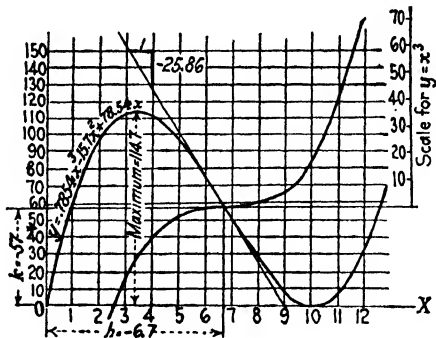

FIG. 92

the value of  $y$  increases to a maximum when  $x = 3.32$  and decreases to zero when  $x = 10$ .

The slope of the graph is zero when  $y$  reaches the maximum value.

## CHAPTER X

### POLYNOMIAL FUNCTIONS

**244. The general form of the polynomial is**

$$a_0x^n + a_1x^{n-1} + a_2x^{n-2} + \dots + a_{n-1}x + a_n.$$

In the addition, subtraction, multiplication, and division of polynomials, since the arrangement of terms is made with the exponent of  $x$  decreased by unity in each succeeding term, the coefficients only need be considered. Where any term is missing, that is, when there is a power of  $x$  which does not appear in the arrangement of terms, the condition should be considered as meaning simply that the coefficient of the term is zero.

**EXAMPLE.**—Add  $x^2 - 1$ ,  $x^4 + 2x^3 + 4x^2 + 3x + 5$ , and

$$2x^3 - 5x^2 + x + 1.$$

$$\begin{array}{r} \phantom{1} \phantom{2} \phantom{4} \phantom{3} \phantom{5} \\ \phantom{1} \phantom{2} \phantom{4} \phantom{3} \phantom{5} \\ \phantom{1} \phantom{2} \phantom{4} \phantom{3} \phantom{5} \\ \phantom{1} \phantom{2} \phantom{4} \phantom{3} \phantom{5} \\ \hline \phantom{1} \phantom{2} \phantom{4} \phantom{3} \phantom{5} \end{array}$$

$$1 \quad 4 \quad 0 \quad 4 \quad 5 = x^4 + 4x^3 + 4x^2 + 5.$$

Multiply

$$2x^3 + 3x^2 - x - 2 \text{ by } x^2 + x + 4.$$

$$\begin{array}{r} 2 \quad 3 \quad - \quad 1 \quad - \quad 2 \\ 1 \quad 1 \quad 4 \\ \hline 2 \quad 3 \quad - \quad 1 \quad - \quad 2 \\ \phantom{2} \phantom{3} \phantom{-} \phantom{1} \phantom{-} \phantom{2} \\ \phantom{2} \phantom{3} \phantom{-} \phantom{1} \phantom{-} \phantom{2} \\ \phantom{2} \phantom{3} \phantom{-} \phantom{1} \phantom{-} \phantom{2} \\ \phantom{2} \phantom{3} \phantom{-} \phantom{1} \phantom{-} \phantom{2} \\ \phantom{2} \phantom{3} \phantom{-} \phantom{1} \phantom{-} \phantom{2} \\ \phantom{2} \phantom{3} \phantom{-} \phantom{1} \phantom{-} \phantom{2} \\ \hline \phantom{2} \phantom{3} \phantom{-} \phantom{1} \phantom{-} \phantom{2} \end{array}$$

$$2 \quad 5 \quad 10 \quad 9 - 6 - 8 = 2x^5 + 5x^4 + 10x^3 + 9x^2 - 6x - 8.$$

**245. The Remainder Theorem.**

**THEOREM.**—If  $f(x)$ , a polynomial, is divided by  $x - c$ , the remainder is  $f(c)$ , the value of  $f(x)$  when  $x$  is put equal to  $c$ .

**PROOF.**—If  $f(x)$  is divided by  $x - c$ , let the quotient be the polynomial  $Q(x)$ , and the remainder, the constant  $R$ , so that

$$\frac{f(x)}{x - c} = Q(x) + \frac{R}{x - c}.$$

We desire to prove that

$$R = f(c).$$

From

$$f(x) = a_0x^n + a_1x^{n-1} + \dots + a_{n-1}x + a_n \text{ and}$$

$$f(c) = a_0c^n + a_1c^{n-1} + \dots + a_{n-1}c + a_n,$$

we get

$$\begin{aligned} f(x) - f(c) &= a_0x^n + a_1x^{n-1} + \dots + a_{n-1}x + a_n \\ &\quad - (a_0c^n + a_1c^{n-1} + \dots + a_{n-1}c + a_n) = \\ &\quad a_0(x^n - c^n) + a_1(x^{n-1} - c^{n-1}) + \dots + a_{n-1}(x - c). \end{aligned}$$

Since  $x - c$  occurs as a factor in all terms, it can be placed outside of a parenthesis and we can denote what is left in the parenthesis by  $Q(x)$ . We then have

$$f(x) - f(c) = (x - c)[Q(x)].$$

Transposing, we get

$$f(x) = (x - c)[Q(x)] + f(c).$$

And dividing by  $(x - c)$  gives

$$\frac{f(x)}{x - c} = Q(x) + \frac{f(c)}{x - c}, \text{ or } R = f(c),$$

which was to be proved.

**EXAMPLE.**—Let  $f(x) = 2x^3 + 3x^2 - 4x - 6$ , and let  $c = 2$ .

$$\begin{array}{r} 2x^3 + 3x^2 - 4x - 6 \mid x - 2 \\ \underline{2x^3 - 4x^2} \phantom{- 6} \\ 7x^2 - 4x \phantom{- 6} \\ \underline{7x^2 - 14x} \phantom{- 6} \\ 10x - 6 \\ \underline{10x - 20} \\ 14 \end{array}$$

$$f(c) = 2 \cdot 2^3 + 3 \cdot 2^2 - 4 \cdot 2 - 6 = 14 = \text{the remainder.}$$

#### 246. The Factor Theorem.

**THEOREM.**—If  $c$  is a root of  $f(x) = 0$  ( $f[x]$  being a polynomial), then  $x - c$  is a factor of  $f(x)$ .

**PROOF.**—If  $c$  is a root of  $f(x) = 0$ ,  $f(c) = 0$ . By the remainder theorem, we know that when  $f(x)$  is divided by  $x - c$ , the remainder is  $f(c)$ , or 0; and if the remainder is 0,  $f(x)$  must be exactly divisible by  $x - c$ .

*Conversely:*

If a polynomial  $f(x)$  is divisible by  $x - c$ , then  $c$  is a root of the equation  $f(x) = 0$ .

**247. Short-cut Division. Synthetic Method.**—When the divisor is  $x - c$  and the dividend of the form,

$$f(x) = a_0x^n + a_1x^{n-1} + \dots + a_{n-1}x + a_n,$$

where the  $a$ s are all integers, the ordinary process of division may be greatly shortened.

Let us assume a problem with the division made in the usual manner.

$$\begin{array}{r} \text{Divide } f(x) = 2x^4 - 9x^3 - 4x^2 - 25 \text{ by } x - 5. \\ 2x^4 - 9x^3 - 4x^2 - 0x - 25 \overline{)x - 5} \\ \underline{2x^4 - 10x^3} \phantom{- 4x^2 - 25} \phantom{+ 5} \\ \phantom{2x^4 - } 10x^3 - 4x^2 - 25 \phantom{+ 5} \\ \phantom{2x^4 - } \underline{10x^3 - 50x^2} \phantom{- 25} \phantom{+ 5} \\ \phantom{2x^4 - } \phantom{10x^3 - } 46x^2 - 25 \phantom{+ 5} \\ \phantom{2x^4 - } \phantom{10x^3 - } \underline{46x^2 - 230x} \phantom{+ 5} \\ \phantom{2x^4 - } \phantom{10x^3 - } \phantom{46x^2 - } 230x - 25 \phantom{+ 5} \\ \phantom{2x^4 - } \phantom{10x^3 - } \phantom{46x^2 - } \underline{230x - 1150} \phantom{+ 5} \\ \phantom{2x^4 - } \phantom{10x^3 - } \phantom{46x^2 - } \phantom{230x - } 1125 \phantom{+ 5} \end{array}$$

Since the function has had its terms arranged in a descending series with the missing terms supplied by 0s, we may disregard the  $x$ s for they are simply carriers, and consider only the  $a$ s which are the coefficients of the  $x$ s. We, therefore, write down only the coefficients as follows:

$$\begin{array}{r} 2 - 9 - 4 \quad 0 - 25 \overline{)1 - 5} \\ -10 \phantom{0 - 25} \overline{)2 + 1 + 1 + 5} \\ \hline +1 \\ \phantom{+1} - 5 \\ \hline +1 \\ \phantom{+1} - 5 \\ \hline +5 \\ \phantom{+5} - 25 \\ \hline \end{array}$$

Since the minus sign of 5 in the divisor changes every sign in forming the partial product, if we replace  $-5$  by  $5$ , we may add the partial products to the numbers in the dividend instead of subtracting them.

Bringing all of the numbers in line, we have

$$\begin{array}{r} 2 - 9 - 4 \quad 0 - 25 \overline{)5} \\ + 10 + 5 + 5 + 25 \overline{) } \\ \hline 2 + 1 + 1 + 5 + 0 \end{array}$$

The last number (in this case, 0) is the remainder and is, therefore, the value of  $f(x)$  when  $x$  is replaced by 5, or simply  $f(5)$ , since, from the remainder theorem, the value of  $f(5)$  is equal to the remainder when  $f(x)$  is divided by  $x - 5$ .

Also observe that the numbers in the last line are the coefficients of the  $x$  series in the quotient. In this case, the quotient is

$$2x^3 + x^2 + x + 5.$$

**RULE.**—Write the coefficients of the terms of the polynomial in order, supplying 0 wherever a term is missing. Multiply the number to be substituted for  $x$  by the first coefficient and add (algebraically) the product to the second coefficient. Multiply this sum by the number to be substituted for  $x$ , add to the third coefficient, and proceed until all of the coefficients have been used. The last sum obtained is the remainder, which is also the value of the polynomial when the number is substituted for  $x$ , the variable.

**EXAMPLE.**—Divide  $f(x) = 2x^4 - 3x^3 + x^2 - x - 9$  by  $x - 2$ .

$$\begin{array}{r} 2 - 3 + 1 - 1 - 9 \overline{)2} \\ + 4 + 2 + 6 + 10 \overline{) } \\ \hline 2 + 1 + 3 + 5 + 1 \end{array}$$

The last number, +1, is the remainder, the value of  $f(2)$ , and the quotient is  $2x^3 + x^2 + 3x + 5$ .

**248. Finding Roots of Polynomials.**—The method of the preceding paragraph is also useful in providing an easy way of finding the integral roots of an equation of any degree whatever. In using this device, we test a few numbers as roots and at the same time factor the polynomial.

**EXAMPLE.**—Find the roots of  $4x^3 - x^2 - 19x + 10 = 0$ .

Test 2 for a root.

$$\begin{array}{r} 4 - 1 - 19 + 10 \overline{)2} \\ 8 + 14 + 10 \overline{) } \\ \hline 4 + 7 - 5 \quad 0 \end{array}$$

This process shows that the remainder is zero and 2 is, therefore, a root.  $x - 2$  is a factor.

The quotient is  $4x^2 + 7x - 5$ . Then

$$(x - 2)(4x^2 + 7x - 5) = 0.$$

Solving  $4x^2 + 7x - 5 = 0$  for the remaining roots of the polynomial gives

$$x = \frac{-7 \pm \sqrt{129}}{8}.$$

In choosing the numbers to test as roots, it should be noted that they must be factors of the absolute term, or 10 in the case of the example given, provided that the equation has been cleared of fractions. For instance in the equation,

$$x^4 - 17x^2 - 34x - 30 = 0,$$

the only possible integral roots are

$$\pm 1, \pm 2, \pm 3, \pm 5, \pm 6, \pm 10, \pm 15, \pm 30,$$

which are all factors of 30.

In testing, begin with the smaller numbers, and it will be found that there are no roots larger than 5.

The roots of the above equation are

$$5, -3, -1 + \sqrt{-1}, \quad \text{and} \quad -1 - \sqrt{-1}.$$

**249. Fractional Roots.**—A fraction, as  $\frac{p}{q}$ , can be a root of an equation, provided that the numerator  $p$  is a factor of the constant term and that the denominator  $q$  is a factor of the coefficient of the highest power of  $x$ .

**EXAMPLE.**—Find the fractional roots of

$$24x^5 + 2x^4 - 3x^3 - 21x^2 + x + 6 = 0.$$

The constant term is 6, and the factors of 6 are 1, 2, 3, 6.

The coefficient of the highest term in  $x$  is 24, and the factors of 24 are 1, 2, 3, 4, 6, 8, 12, and 24.

Thus all the possible combinations of these numbers into fractions are

$$\pm \frac{1}{2}, \pm \frac{1}{3}, \pm \frac{2}{3}, \pm \frac{1}{4}, \pm \frac{3}{4}, \pm \frac{1}{6}, \pm \frac{1}{8}, \pm \frac{3}{8}, \pm \frac{1}{12}, \pm \frac{1}{24}.$$

If we test  $+\frac{1}{2}$ , we find that it is not a root. Testing  $-\frac{1}{2}$ ,

$$\begin{array}{r} 24 + 2 - 3 - 21 + 1 + 6 \quad | \quad -\frac{1}{2} \\ - 12 + 5 - 1 + 11 - 6 \\ \hline 24 - 10 + 2 - 22 + 12 \quad 0 \end{array}$$

Since the remainder is zero,  $-\frac{1}{2}$  is a root.

Next try the quotient for  $+\frac{2}{3}$  as a root.

$$\begin{array}{r} 24 - 10 + 2 - 22 + 12 \quad | \quad \frac{2}{3} \\ + 16 + 4 + 4 - 12 \\ \hline 24 + 6 + 6 - 18 \quad 0 \end{array} \quad + \frac{2}{3} \text{ is a root.}$$

Test  $+\frac{1}{3}$

$$\begin{array}{r} + 18 + 18 + 18 \\ \hline 24 + 24 + 24 \quad 0 \end{array} \quad + \frac{1}{3} \text{ is a root.}$$

Dividing the last quotient by 24 gives

$$x^3 + x + 1.$$

The factors of the polynomial are

$$24(x + \frac{1}{2})(x - \frac{2}{3})(x - \frac{1}{4})(x^2 + x + 1).$$

**250. Translation of a Graph by Synthetic Method.**—Consider that the graph of  $y = f(x)$  has been translated  $h$  units to the left so that every value of  $x$  has been replaced by  $x + h$ . Now let the equation of the new curve be

$$[65] \quad y = a_0x^n + a_1x^{n-1} + a_2x^{n-2} + \dots + a_{n-1}x + a_n.$$

If this curve is moved back to its original position, the equation becomes

$$y = f(x) = a_0(x - h)^n + a_1(x - h)^{n-1} + a_2(x - h)^{n-2} + \dots + a_{n-1}(x - h) + a_n.$$

If  $f(x)$  is divided by  $x - h$ , we would have a remainder of  $a_n$  while the quotient would be

$$a_0(x - h)^{n-1} + a_1(x - h)^{n-2} + \dots + a_{n-2}(x - h) + a_{n-1}.$$

Dividing this again by  $x - h$ ,  $a_{n-1}$  is the remainder and the new quotient is

$$a_0(x - h)^{n-2} + a_1(x - h)^{n-3} + \dots + a_{n-2}.$$

Dividing again by  $x - h$  gives  $a_{n-3}$  as a remainder. This division is continued until all the coefficients have been once a remainder. The remainders so obtained are the coefficients of the transformed equation.

**EXAMPLE.**—Translate the graph of  $y = x^3 + 7x^2 - 22x - 4$ , to the left, 2 units and write the equation of the new graph.

$$\begin{array}{r} 1 + 7 - 22 - 4 \mid 2 \\ + 2 + 18 - 8 \\ \hline 1 + 9 - 4 - 12 \\ + 2 + 22 \\ \hline 1 + 11 + 18 \\ + 2 \\ \hline 1 + 13 \end{array}$$

The underlined numbers are the coefficients, and the transformed equation is

$$x^3 + 13x^2 + 18x - 12 = f_1(x).$$



**251. Approximate Solutions for Irrational Roots.**—The method of Art. 250 is useful in obtaining approximate values for the irrational roots of an equation to several decimal places.

If the root is found to be between 2 and 3 and appears to the eye, when the graph has been made, to lie between 2.4 and 2.5, a translation is made which diminishes the roots by 2.4 or to less than .1. This means that the graph has been translated 2.4 units to the left (Fig. 93). If we translate again, say to the left .07 unit, and find that we have a close approximation to the value of  $x$  when we substitute, the approximation to the value of the root is obtained by adding the amounts of the several translations, thus,

$$x = 2 + .4 + .07 = 2.47.$$

**252. The Graphing of Polynomial Functions.**—We can make use of the fact that the remainder, found by synthetic division, gives the value of the function  $y$  for the values of  $x$  substituted, when we desire to draw the graph of the function.

Consider

$$y = x^3 + 3x^2 - 2x - 18.$$

The value of  $y$  when  $x = 0$  is found by direct substitution to be  $-18$ .

Let $x = 1$ .	$\begin{array}{r} 1 + 3 - 2 - 18 \quad   \underline{1} \\ \phantom{1} + 1 + 4 + 2 \end{array}$
	$1 + 4 + 2 - 16$ remainder $-16$ .
Let $x = 2$	$\begin{array}{r} 1 + 3 - 2 - 18 \quad   \underline{2} \\ \phantom{1} + 2 + 10 + 16 \end{array}$
	$1 + 5 + 8 - 2$ remainder $-2$ .
Let $x = 3$	$\begin{array}{r} 1 + 3 - 2 - 18 \quad   \underline{3} \\ \phantom{1} + 3 + 18 + 48 \end{array}$
	$1 + 6 + 16 + 30$ remainder $+30$ .

We can see that when  $x$  is still greater, the remainder will be a positive quantity. We will not plot further in the direction of the positive values of  $x$  but will find the values of  $y$  for some negative values of  $x$ .

Let $x = -1$ .	$\begin{array}{r} 1 + 3 - 2 - 18 \quad   \underline{-1} \\ \phantom{1} - 1 - 2 + 4 \end{array}$
	$1 + 2 - 4 - 14$ remainder $-14$ .

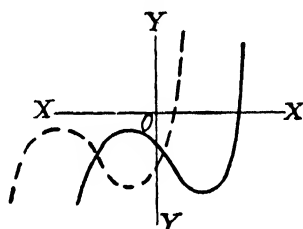

FIG. 93.

Let  $x = -2$ .

$$\begin{array}{r} 1 + 3 - 2 - 18 \quad | \quad -2 \\ \hline -2 - 2 + 8 \end{array}$$

Let  $x = -3$ .

$$\begin{array}{r} 1 + 1 - 4 - 10 \quad \text{remainder } -10. \\ 1 + 3 - 2 - 18 \quad | \quad -3 \\ \hline -3 \quad 0 + 6 \end{array}$$

Let  $x = -4$ .

$$\begin{array}{r} 1 \quad 0 - 2 - 12 \quad \text{remainder } -12. \\ 1 + 3 - 2 - 18 \quad | \quad -4 \\ \hline -4 + 4 - 8 \\ 1 - 1 + 2 - 26 \quad \text{remainder } -26. \end{array}$$

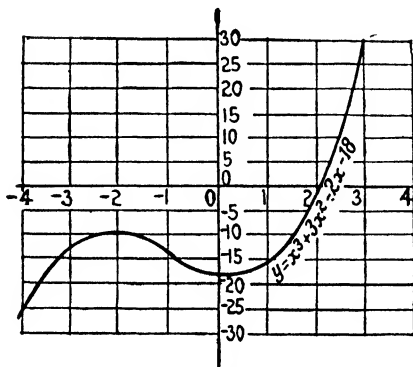

FIG. 94.

All negative values of  $x$  numerically greater than 4 result in negative remainders. We next put the results in tabular form for convenience in plotting.

$x$	$y$
-4	-26
-3	-12
-2	-10
-1	-14
0	-18
1	-16
2	-2
3	+30

Where the curve intersects the  $X$ -axis are found the roots of the equation. In this case there is only one real root and two imaginary. See Arts. 254 and 260 following.

### 253. Application of Synthetic Translation (Horner's Method).

To find an approximation to the irrational root of

$$x^3 + 3x^2 - 2x - 18 = 0$$

which was plotted in the previous article, we see that there is a root between 2 and 3, and hence, we translate 2 units to the left.

$$\begin{array}{r}
 1 + 3 - 2 - 18 \quad | \underline{2} \\
 + 2 + 10 + 16 \\
 \hline
 1 + 5 + 8 - 2 \\
 + 2 + 14 \\
 \hline
 1 + 7 + 22 \\
 + 2 \\
 \hline
 1 + 9
 \end{array}$$

The equation of the translated curve is

$$x^3 + 9x^2 + 22x - 2 = 0.$$

With  $h = 2$ , we have a remainder of  $-2$  and estimate that  $h$  for the next translation should be about .08 to make the remainder close to zero.

$$\begin{array}{r}
 1 + 9.00 + 22.0000 - 2.0000 \quad | \underline{.08} \\
 + .08 + .7264 + 1.8181 \\
 \hline
 1 + 9.08 + 22.7264 - 0.1819 \\
 .08 \quad .7328 \\
 \hline
 1 + 9.16 + 23.4592 \\
 .08 \\
 \hline
 1 + 9.24
 \end{array}$$

The new equation is

$$x^3 + 9.24x^2 + 23.4592x - 0.1819 = 0,$$

which shows a constant term,  $-0.1819$ . For the next translation, try  $h = .007$ .

$$\begin{array}{r}
 1 + 9.240 + 23.4592 - 0.1819 \quad | \underline{.007} \\
 + .007 + .0647 + 0.1647 \\
 \hline
 1 + 9.247 + 23.5239 - 0.0172 \\
 + .007 + .0648 \\
 \hline
 1 + 9.254 + 23.5887 \\
 + .007 \\
 \hline
 1 + 9.261
 \end{array}$$

The new equation is

$$x^3 + 9.261x^2 + 23.5887x - 0.0172 = 0.$$

The last translation results in a very small constant term, and instead of continuing, we resort to another method of approximation.

$x$  is now very small and  $x^2$  and  $x^3$  are so small that they may be disregarded and we have

$$\begin{aligned} 23.5887x &= 0.0172. \\ x &= 0.00072. \end{aligned}$$

Adding the translations we have made, we have the root equal to

$$2 + .08 + .007 + .00072 = 2.08772.$$

This whole method of approximation is known as the Horner method.

**254. Multiple Roots.**—Some equations like

$$x^3 - 8x^2 + 21x - 18 = 0$$

are satisfied by only two numbers, 2 and 3; but we say that 3 is a *double root* because  $(x - 3)^2$  is a factor of

$$x^3 - 8x^2 + 21x - 18.$$

*A polynomial equation of the  $n$ th degree has exactly  $n$  roots if we count both real and imaginary roots and count the multiple roots as many times as the degree of their multiplicity.*

If a rational integral equation with real coefficients has the complex number,  $c + id$ , as one of its roots, it must also have the complex number,  $c - id$ , for a root, and hence, the complex

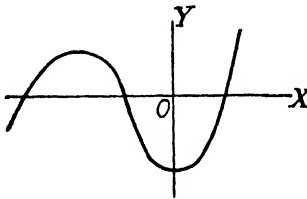

FIG. 95.

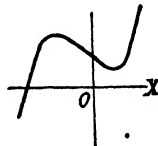

FIG. 96.

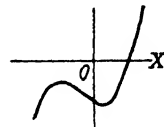

FIG. 97.

roots occur in pairs. It follows that every equation of odd degree with real coefficients has at least one real root. The graphs of polynomials of higher degree than the second usually take the form of a number of loops as shown in Fig. 95.

If the  $X$ -axis is tangent to the curve, there is a pair of real and equal roots represented by the abscissa of the point of tangency. In the case where the loops have been translated above or below the  $X$ -axis by the translating members, the equation will have complex roots. The nature of the graph when this condition exists is shown in Figs. 96 and '97. There may also be complex roots without any such loop occurring in the graph.

Complex roots occur in pairs, and for each vertex of the curve, there is a pair of complex roots, unless as before stated, the curve is tangent to the  $X$ -axis at one of these vertices, in which case the point represents two roots, real and equal.

The greater the difference between the values of the roots, the more pronounced the divergence of the parts of the curve on either side of the loops will be, and the nearer the values of the roots are to each other, the nearer the sections of the curve come to each other.

If the binomial surd,  $a + \sqrt{b}$ , is a root of an equation with rational coefficients, then its conjugate,  $a - \sqrt{b}$ , is also a root of the same equation, and conversely.

**255. Relations between the Roots and the Coefficients of the General Equation of  $n$ th Degree.**—In the general form,

$$x^n + p_1x^{n-1} + p_2x^{n-2} + \dots + p_{n-1}x + p_n = 0,$$

which is obtained from [65] by dividing by  $a_0$ :

The sum of the roots is equal to the coefficient of the second term with its sign changed, or if  $n = 4$ ,

$$x_1 + x_2 + x_3 + x_4 = -p_1.$$

The sum of the products of the roots, taken two at a time, is equal to the coefficient of the third term, thus,

$$x_1x_2 + x_1x_3 + x_1x_4 + x_2x_3 + x_2x_4 + x_3x_4 = p_2.$$

The sum of the products of the roots, taken three at a time, equals the coefficient of the fourth term with its sign changed,

$$x_1x_2x_3 + x_1x_2x_4 + x_1x_3x_4 + x_2x_3x_4 = -p_3$$

The product of the roots is equal to the constant term, with its sign changed if  $n$  is odd,

$$x_1x_2x_3x_4 = p_4.$$

**256. To Form an Equation When the Roots Are Given.**—If the given roots are  $x_1, x_2, x_3, \dots, x_n$ , by multiplying together the factors,  $x - x_1, x - x_2, x - x_3, \dots, x - x_n$ , and setting the product equal to zero, we obtain the equation.

**EXAMPLE.**—Assume the roots, 4,  $-3$ ,  $\pm \frac{1}{2}$ .

$$\therefore (x - 4)(x + 3)(x - \frac{1}{2})(x + \frac{1}{2}) = 0.$$

Multiplying, we have  $x^4 - x^3 - \frac{5}{4}x^2 + \frac{1}{4}x + 27 = 0$ , or

$$4x^4 - 4x^3 - 57x^2 + 9x + 108 = 0.$$

The graph of this equation is shown in Fig. 98.

We can also find the equation by use of the relations of Art. 255, thus,

$$p_1 = -(4 - 3 + \frac{3}{2} - \frac{3}{2}) = -1.$$

$$p_2 = 4(-3) + 4(\frac{3}{2}) + 4(-\frac{3}{2}) + (-3)(\frac{3}{2}) + (-3)(-\frac{3}{2}) + (\frac{3}{2})(-\frac{3}{2}) \\ = -12 - \frac{9}{4} = -\frac{57}{4}.$$

$$p_3 = -\{4(-3)(\frac{3}{2}) + 4(-3)(-\frac{3}{2}) + 4(\frac{3}{2})(-\frac{3}{2}) + (-3)(\frac{3}{2})(-\frac{3}{2})\} = \\ -\{-\frac{36}{2} + \frac{36}{2} - \frac{36}{2} + \frac{36}{2}\} = \frac{9}{2}.$$

$$p_4 = 4(-3)(\frac{3}{2})(-\frac{3}{2}) = \frac{108}{2}.$$

Hence the equation,

$$x^4 - x^3 - \frac{57}{4}x^2 + \frac{9}{2}x + \frac{108}{2} = 0, \text{ or} \\ 4x^4 - 4x^3 - 57x^2 + 9x + 108 = 0.$$

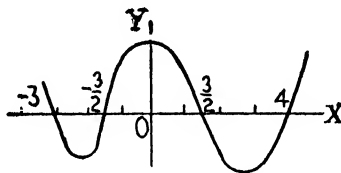

FIG. 98.

**257. Aids to Graphical Solutions.**—After plotting the graph of a polynomial (using the synthetic method of Art. 252 to obtain the values of  $y$  for different values of  $x$ ), first determine whether any rational values of  $x$  can be solutions. Bear in mind that the constant term  $p_n$  when the equation has been put into the form,

$$x^n + p_1x^{n-1} + p_2x^{n-2} + \dots + p_{n-1}x + p_n = 0,$$

is the product of the roots. If, for instance, the constant  $p_n$  is 3, then  $\pm 3$ , or  $\pm 1$  are the roots, if the roots are rational.

**258. Roots Multiplied by a Constant.**—If in

$$f(x) = a_0x^n + a_1x^{n-1} + a_2x^{n-2} + \dots + a_{n-1}x + a_n = 0$$

we represent the roots by  $x_1, x_2, x_3, \dots, x_n$ , and we wish to form an equation having roots  $k$  times those of the original

equation, we replace  $x$  by  $\frac{x}{k}$  giving

$$f\left(\frac{x}{k}\right) = a_0\left(\frac{x}{k}\right)^n + a_1\left(\frac{x}{k}\right)^{n-1} + \dots + a_{n-1}\left(\frac{x}{k}\right) + a_n = 0,$$

and clearing of fractions, the desired equation is

$$a_0x^n + a_1kx^{n-1} + a_2k^2x^{n-2} + \dots + a_{n-1}k^{n-1}x + k^na_n = 0.$$

**259. Equations Having Roots Numerically Equal but Opposite in Sign to the Roots of a Given Equation.**—If we desire to form

an equation whose roots are the negatives of the roots of a given equation, we may do this by changing the signs of the alternate terms of the given equation.

It is evident that this is merely the process of the preceding paragraph with  $k = -1$ .

**260. Descartes' Rule of Signs.**—An equation in the general form,  $f(x) = 0$ , has no more real positive roots than  $f(x)$  has changes of sign.

The general equation,  $f(x) = 0$ , has no more real negative roots than  $f(-x)$  has changes of sign.

If  $a =$  the number of positive roots, and

$b =$  the number of negative roots, then

$n - (a + b) =$  the number of complex roots, where  $n$  is the degree of the equation.

The graphical method of solving polynomial equations is to be recommended for engineering purposes. In the event of very exact values of the function being desired, that part of the curve which lies in the vicinity of the intersections of the graph and the  $X$ -axis can be drawn to a very large scale and the results obtained with a corresponding degree of accuracy.

## CHAPTER XI

### POWER FUNCTIONS

**261. Power Functions.**—The algebraic functions consisting of a single power of the variable, such as

$$x^2, x^3, \frac{1}{x^2}, x^1, ax^{-2}, \text{ etc.},$$

are examples of the power function.

In importance it lies next to the linear functions, and in fact; the power function,  $y = ax^n$ , is one of the three basic laws of natural phenomena.

In Art. 170 we have analyzed the function obtained by squaring the variable and it is unnecessary to add anything to that discussion, excepting perhaps to call the attention to some natural laws which depend upon it. Thus, the area of a circle varies as the square of its radius, and the distance traversed by a falling body varies as the square of the elapsed time. Many other examples like the ones mentioned could be cited to indicate the importance of the power function,  $y = ax^2$ .

So, too, we have many other relations of variables of the form,  $y = ax^3$ , such as the relation between the volume of a sphere and its radius, or the volume of a cube and its side. We have also treated the function,  $y = ax^3$ , in Art. 232 with sufficient detail for our purpose. We will, therefore, take up the discussion of some of the additional power functions which have not been mentioned in our treatment of these two special cases.

The value of  $a$  is different for every problem, although it retains a constant value throughout a given discussion. It was observed in Art. 232 what the effect was of  $a$  upon the graph of  $y = x^n$ .

**262. Case 1.  $y = x^n$  [66] with  $n$  Positive.**—All equations of this type, as  $y = x$ ,  $y = x^2$ , etc., are represented by curves which have the common property of passing through the points  $(0, 0)$  and  $(1, 1)$ , and which are called parabolic curves.



$y = x^2$  is called a parabola.

$y = x^3$  is called a cubic parabola.

$y = x^{\frac{1}{2}}$  is called a semicubical parabola.

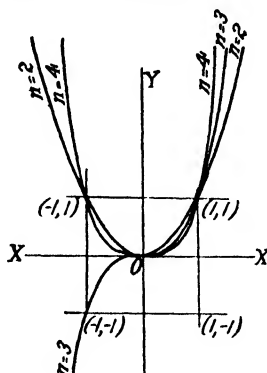

FIG. 99.

The forms of these curves for some integral values of  $n$  are shown in Fig. 99.

The graphs of these curves can be made straight lines by using logarithmic coordinate paper as shown in Figs. 127 and 128.

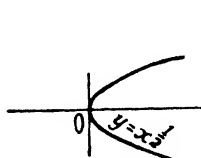

FIG. 100.

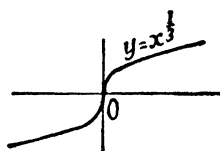

FIG. 101.

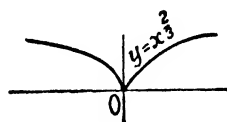

FIG. 102.

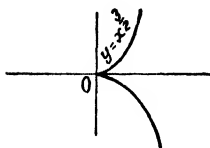

FIG. 103.

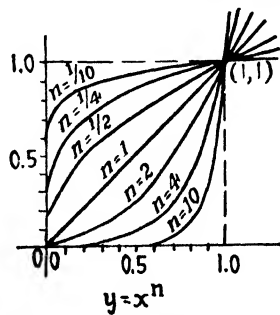

FIG. 104.

**263. Parabolas with  $n$  Fractional.**—The relation of the graphs of  $y = x^n$  for different fractional values of  $n$  are shown in Figs. 100,

101, 102, and 103. In Fig. 104 are shown the graphs of the function for various fractional values of  $n$  as they appear in the first quadrant.

**264. Case 2.  $y = x^n$  [66] with  $n$  Negative.**—These curves are called hyperbolic curves.

These functions take the general form,  $y = x^{-n}$ , or  $y = \frac{1}{x^n}$ , which can be put into the form,  $yx^n = 1$ , with  $n > 0$ .

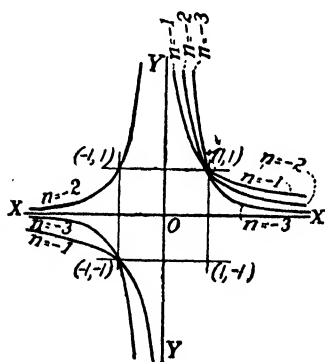

FIG. 105.

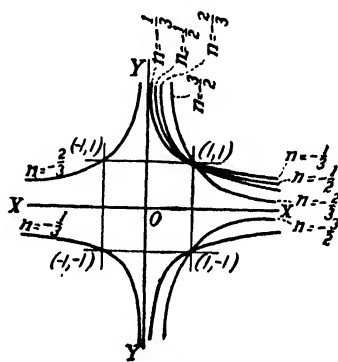

FIG. 106.

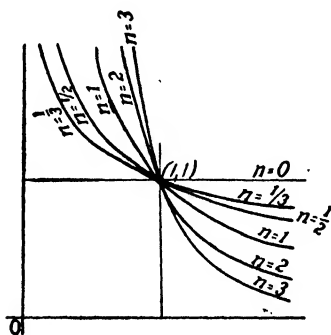

FIG. 107.

The special case,  $xy = 1$ , we have noted (Art. 206), is a rectangular hyperbola.

Figure 105 shows the graphs of some of the hyperbolic functions for various negative integral values of  $n$ .

Figure 106 shows the graphs of  $y = x^n$  when  $n$  has various negative fractional values.

Figure 107 represents the function,  $y = x^{-n}$ , for different values of  $n$  showing the appearance of the curve in the first quadrant.

The hyperbolic curves of the forms just given approach the asymptotes, the asymptotes being the  $X$ - and  $Y$ -axes. The rate at which they approach the axes depends upon the relative magnitudes of the exponents of  $x$  and  $y$ . The quadrants in which the curves lie are determined by the oddness or evenness of these exponents.

**265. Change of Variable.**—If  $x$  be replaced by  $(-x)$  in any equation containing  $x$  and  $y$ , the graph of the function so formed is the reflection of the original function with respect to the axis  $OY$ .

**266.** If  $y$  be replaced by  $(-y)$  in any function containing  $x$  and  $y$ , the graph of the transformed function is the reflection of the original function with respect to the  $OX$ -axis.

**267.** If  $x$  and  $y$  be interchanged in any function involving them, the function will be represented by a curve, which is the reflection of the graph of the original function with respect to the line  $y = x$ .

**268.** If a function remains unchanged, when  $x$  is replaced by  $(-x)$ , its graph is symmetrical with respect to the  $Y$ -axis.

**269.** If a function remains unchanged, when  $y$  is replaced by  $(-y)$ , its graph is symmetrical with respect to the  $X$ -axis.

**270.** If a function remains unchanged, when  $x$  and  $y$  are interchanged, its graph is symmetrical with respect to the line  $y = x$ .

**271.** If a function remains unchanged, when  $x$  is replaced by  $(-x)$  and  $y$  is replaced by  $(-y)$ , its graph is symmetrical with respect to the origin.

**272.** If a function is unchanged by the substitution of  $(-y)$  for  $x$  and  $(-x)$  for  $y$ , its graph is symmetrical with respect to the line  $y = -x$ .

**273.** Substituting  $\left(\frac{x}{a}\right)$  for  $x$  in the equation of any locus multiplies all of the abscissae of the curve by  $a$ .

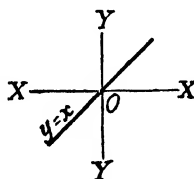

FIG. 108.

274. Substituting  $\left(\frac{y}{a}\right)$  for  $y$  in the equation of any locus multiplies all of the ordinates of the curve by  $a$ .

275. The Functions,  $y = ax^n$  and  $y = x^n$  (Arts. 261 and 232).—The constant  $a$  increases or decreases the value of the function, or  $y$ , in the function,  $y = x^n$ , in the ratio of  $a$  to 1.

If  $a$  is greater than 1,  $y$  is increased, and if  $a$  is less than 1,  $y$  is decreased, when compared to its value in  $y = x^n$ .

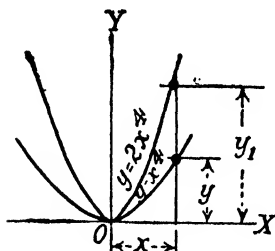

Fig. 109.

Thus, in Fig. 109 are shown the graphs of  $y = x^4$  and  $y_1 = 2x^4$ .

It will be readily seen that any ordinate  $y_1$  is twice the length of the corresponding ordinate  $y$ .

276. In  $y = ax^n$ , where  $n$  is any positive number, the relation between the variables is often expressed by the statement,

$y$  varies as the  $n$ th power of  $x$ , or  
 $y$  is proportional to  $x^n$ .

Likewise, in the case of the function,  $y = \frac{a}{x^n}$ , the relation is expressed by the statement,

$y$  varies inversely as the  $n$ th power of  $x$ , or  
 $y$  is inversely proportional to  $x^n$ .

277. In any power function of  $x$ , if  $x$  changes by a fixed multiple,  $y$  will change by a fixed multiple also.

Assume  $y = ax^n$ , and take different values of  $x$  and the corresponding values of  $y$ , as  $x_1$ ,  $x_2$ , and  $y_1$ ,  $y_2$ .

$$y_1 = a(x_1)^n. \quad (1)$$

$$y_2 = a(mx_1)^n = am^n(x_1)^n. \quad (2)$$

Dividing (2) by (1),

$$\frac{y_2}{y_1} = \frac{am^n(x_1)^n}{a(x_1)^n} = m^n.$$

This means that if  $x$  in any power function changes by the fixed multiple  $m$ , then the value of the function  $y$  will change by the fixed multiple  $m^n$ .

This law is used to determine whether experimental data are related according to some power function relation.

**278. Case of the Function [67],  $y = \left(\frac{x}{a}\right)^n$ .**—The graph of  $y = \left(\frac{x}{a}\right)^n$  can be made from the graph of  $y = x^n$  by multiplying all of the abscissae of the latter graph by  $a$ . The ratio of the abscissae of the two curves is  $a$  to 1.

The two curves are shown plotted in Fig. 110 where the two may be compared and the method of obtaining one from the other may be readily seen. This follows from Art. 273 which stated that the substitution of

$\left(\frac{x}{a}\right)$  for  $x$  in any equation of locus multiplies all of the abscissae of the curve by  $a$ .

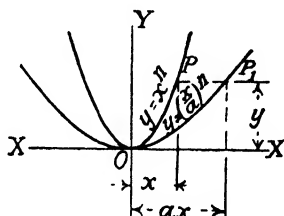

FIG. 110.

**279. Translation of Power Function**

**Graphs.**—If  $(x + h)$  is substituted for  $x$  in the power function, we have

[68] 
$$y = (x + h)^n.$$

This results in a translation of the origin a distance  $h$  in the  $X$ -direction in the same manner as in the case of the quadratic (Art. 172).

If we first draw the graph of the function,  $y = x^n$ , and wish to transform it into a graph of the function,  $y = (x + h)^n$ , we shift the origin to the point  $(h, 0)$  and the equation of the curve referred to the new origin is  $y = (x + h)^n$ .

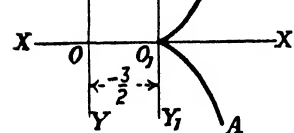

FIG. 111.

**EXAMPLE.**—Translate the graph of  $y = x^3$  so that it represents the function,  $y = \left(x - \frac{3}{2}\right)^3$ .

Draw the graph of  $y = x^3$  represented in Fig. 111 by  $AOB$ , using the temporary axes,  $YY_1$  and  $XX_1$ . Then, since  $h = -\frac{3}{2}$ , shift the origin  $\frac{3}{2}$  units in the negative  $X$  direction, or to the left as shown.

Note that  $y = x^3$  can also be written,  $y^2 = x^3$ , and it will often be found in this form.

**280. Case Where the  $mx$  Term Appears in the Power Function.**—The addition of a term in  $x$ , such as  $mx$ , to the power

function,  $y = ax^n$ , puts a shear in the graph in the same manner as in the cubic or quadratic equations and is handled in the same manner (see Art. 234).

If  $m = 1$ , we have  $y = ax^n + x$ .

This indicates that the value of  $y$  in  $y = ax^n$  is increased or decreased by an amount equal to  $x$ .

If  $x$  is positive, we have an increase in the value of  $y$ , and if  $x$  is negative, we have a decrease in the value of  $y$ .

We can accomplish this addition or subtraction of the  $x$  term by drawing a line through the origin having a slope of  $m$  and measuring the values of  $y$  from this line.

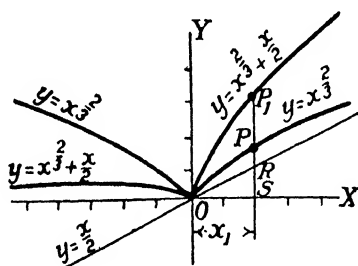

FIG. 112.

EXAMPLE.—By shearing the graph of  $y = x^3$ , change it to represent the function,  $y = x^3 + \frac{x}{2}$ .

Draw the graph of  $y = x^3$  as shown in Fig. 112.

Draw  $y = \frac{x}{2}$  with a slope of  $\frac{1}{2}$ .

Take any distance  $x$  and with a compass transfer  $y = SP$  to  $RP_1$ , locating the point  $P$  in its new position  $P_1$ .

Continue in this manner until several points are located and then draw the graph through these points.

The new graph is the graph of the function,  $y = x^3 + \frac{x}{2}$ .

## CHAPTER XII

### INEQUALITIES AND VARIATION

**281. Inequalities.**—One number is said to be greater than another if, when the second is subtracted from the first, the remainder is positive.

If  $a$  is greater than  $b$ , the fact is denoted by writing,  $a > b$ . If  $a$  is less than  $b$ , it is written,  $a < b$ . The signs  $\nabla$  and  $\triangleleft$  are read “is not greater than” and “is not less than,” respectively.

When the first two numbers of two inequalities are each greater than, or less than, the corresponding second members of the inequalities, the inequalities are said to subsist in the same sense.  $x > a$  and  $y > b$  subsist in the same sense.

When the first member is greater in one inequality and less in another, the inequalities are said to subsist in a contrary sense.  $x > b$  and  $y < a$  subsist in a contrary sense.

**282.** If the same number be added to, or subtracted from, both members of an inequality, the resulting inequality will subsist in the same sense.

Let  $a > b$  and let  $c$  be any positive or negative number.

Then  $a - b = p$ , a positive number.

Adding  $c - c = 0$ , we have

$$a + c - (b + c) = p.$$

Therefore,

$$a + c > b + c.$$

#### EXAMPLES.

Given	$8 > 5$
Add	$\begin{array}{r} 2 \\ 2 \end{array}$
	$\hline 10 > 7$

Given	$8 > 5$
Subtract	$\begin{array}{r} 2 \\ 2 \end{array}$
	$\hline 6 > 3$

**283.** If both members of an inequality are multiplied or divided by a positive number, the resulting inequality will subsist in the same sense, but if both members of an inequality are multiplied or divided by a negative number, the resulting inequality will subsist in a contrary sense.

Let  $a > b$  and let  $c$  be any positive number.

Then  $a - b = p$ , a positive number.

Multiplying,  $ca - cb = cp$ , which is positive.

Therefore,  $ca > cb$ .

**284.** Multiplying by  $-1$  changes the signs of both members of the equation,  $ca - cb = cp$ , so that  $cb - ca = -cp$ , which is a negative number. Writing this last equation in the form,

$-ca - (-cb) = \text{a negative number}$ , we see that

$$-ca < -cb.$$

Given	$8 > 5$	$16 > 10$	Given	$16 > 10$	$16 > 10$
Multiply	$\frac{2}{2}$	$\frac{-2}{-2}$	Divide	$\frac{2}{2}$	$\frac{-2}{-2}$
	$16 > 10$	$-32 < -20$		$8 > 5$	$-8 < -5$

**285.** A term may be transposed from one side of an inequality to the other providing that its sign is changed.

Let  $a - b > c - d$ .

Adding  $b$  to each side (Art. 282),  $a > c - d + b$ .

Adding  $-c$  to each side,  $a - c > b - d$ .

**286.** If the signs of all the terms of an inequality are changed, the resulting inequality will subsist in the contrary sense. This follows from Art. 283, since changing the signs is equivalent to multiplying by  $-1$ , or it can be seen that if  $a - b > c - d$  and we transpose all of the terms Art. 285,  $d - c > b - a$ , or  $-a + b < -c + d$ .

**287.** If the corresponding members of any number of inequalities subsisting in the same sense are added, the resulting inequality will subsist in the same sense.

Let  $a > b$ ,  $c > d$ ,  $e > f$ , etc.

Then  $a - b$ ,  $c - d$ ,  $e - f$ , etc., are all positive and their sum,

$$(a + c + e + \dots) - (b + d + f + \dots), \text{ is positive.}$$

That is,

$$(a + c + e + \dots) > (b + d + f + \dots).$$

**288.** If each member of an inequality is subtracted from the corresponding member of an equation, the resulting inequality will subsist in the contrary sense.

Let  $a > b$  and let  $c$  be any number.

Then  $a - b = \text{a positive number}$  and since a number is diminished by subtracting a positive number from it,

$$c - (a - b) < c.$$



Transposing,

$$c - a < c - b.$$

That is, if each member of the inequality,  $a > b$ , is subtracted from the corresponding member of the equation,  $c = c$ , the resulting inequality subsists in the contrary sense.

**289.** If  $a > b$  and  $b > c$ , then  $a > c$ , for

$$a - b = \text{a positive number, and}$$

$$b - c = \text{a positive number.}$$

Therefore,

$$(a - b) + (b - c) = \text{a positive number.}$$

Simplifying,

$$a - c = \text{a positive number, and hence,}$$

$$a > c.$$

NOTE.—In a similar manner it may be shown that if  $a < b$  and  $b < c$ , then  $a < c$ .

**291.** If the corresponding members of two inequalities are multiplied together, the resulting inequality will subsist in the same sense if all of the members are positive. Let  $a > b$  and  $c > d$ , where  $a$ ,  $b$ ,  $c$ , and  $d$  are all positive. Multiplying the first inequality by  $c$  and the second by  $b$ ,

$$ac > bc \text{ and } bc > bd.$$

Hence, by Art. 289,  $ac > bd$ .

NOTE.—When some of the members are negative, the result may be an inequality subsisting in the same sense or in a contrary sense, or it may be an equation.

Thus take the inequality,  $12 > 6$ .

Multiplying by the inequality,  $-2 > -5$ , member by member,

$$-24 > -30.$$

Multiplying by the inequality,  $-2 > -4$ , member by member,

$$-24 = -24.$$

Multiplying by the inequality,  $-2 > -3$ , member by member,

$$-24 < -18.$$

**292.** The quotient of two inequalities, member by member, may have its first member greater than, less than, or equal to its second member.

Take the inequality,  $12 > 6$ .

Dividing by the inequality,  $3 > 2$ , member by member,  $4 > 3$ .

Dividing by the inequality,  $4 > 2$ , member by member,  $3 = 3$ .  
 Dividing by the inequality,  $6 > 2$ , member by member,  $2 < 3$ .

### 293. Problems.

EXAMPLE 1.—Find the values of  $x$  which satisfy the inequality,  $3x - 10 > 11$ .

Transposing by Art. 285 or adding 10, by Art. 282,

$$3x > 21.$$

Dividing by 3, according to Art. 283,

$$x > 7.$$

Therefore, for all values of  $x$  greater than 7, the inequality is true, or we say that the inferior limit of  $x$  is 7.

EXAMPLE 2.—Find the values of  $x$  which satisfy the simultaneous inequalities,

$$3x + 5 < 38 \text{ and} \quad (1)$$

$$4x < 7x - 18. \quad (2)$$

Transposing in (1), by Art. 285,

$$3x < 33.$$

Dividing by 3, according to Art. 283,

$$x < 11.$$

Transposing in (2), by Art. 285,

$$-3x < -18.$$

Dividing by  $-3$ , according to Art. 283,

$$x > 6.$$

The results show that the given inequalities are satisfied simultaneously by any value of  $x$  between 6 and 11. That is, the inferior limit of  $x$  is 6, and the superior limit is 11.

EXAMPLE 3.—Find what values of  $x$  and  $y$  satisfy the conditions:

$$3x - y > -14 \text{ and} \quad (1)$$

$$x + 2y = 0. \quad (2)$$

Multiplying (1) by 2,

$$6x - 2y > -28. \quad (3)$$

Adding (2) and (3),

$$7x > -28. \quad (4)$$

Dividing (4) by 7,

$$x > -4.$$

Multiplying (2) by 3,

$$3x + 6y = 0. \quad (5)$$

Subtracting (5) from (1),

$$-7y > -14.$$

Dividing by  $-7$

$$y < 2.$$

That is, the inferior limit of  $x$  is  $-4$ , and the superior limit of  $y$  is 2.

EXAMPLE 4.—Find what values of  $x$  satisfy the inequality,  $x^2 + 3x > 28$ .

Transposing,  $x^2 + 3x - 28 > 0$ .

Factoring,  $(x - 4)(x + 7) > 0$ .

That is,  $(x - 4)(x + 7)$  is positive, and, therefore, either both factors are positive, or both are negative. Both factors are positive when  $x > 4$ , and both factors are negative when  $x < -7$ .

Hence,  $x$  may have all values except 4 and  $-7$  and the values between these numbers.

EXAMPLE 5.—If  $a$  and  $b$  are positive and unequal, prove that

$$a^2 + b^2 > 2ab.$$

Whether  $(a - b)$  is positive or negative,  $(a - b)^2$  will be positive, and since  $a$  and  $b$  are unequal,

$$(a - b)^2 > 0.$$

That is,

$$a^2 - 2ab + b^2 > 0.$$

Transposing, according to Art. 285,

$$a^2 + b^2 > 2ab.$$

NOTE.—If  $a = b$ , it is evident that  $a^2 + b^2 = 2ab$ .

**294. Variation.**—Many problems have to do with quantities that are constantly changing. These quantities are called *variables*.

One quantity is said to vary directly as another, or to “vary as another” when the two depend upon each other in such a manner that if one is changed, the other is changed in the same ratio.

The sign of variation is  $\propto$  and is read “varies as.” Thus,  $x \propto y$  is a brief way of writing the proportion,

$$x : x' = y : y'$$

in which  $x'$  is the value to which  $x$  is changed when  $y$  is changed to  $y'$ .

The expression  $x \propto y$  means that if  $x$  is doubled,  $y$  is doubled. That is, the ratio of  $x$  to  $y$  is always the same or is equal to a constant.

If the constant ratio is represented by  $k$ , then when  $x \propto y$ ,  $\frac{x}{y} = k$ , or  $x = ky$ .

If  $x$  varies as  $y$  ( $x \propto y$ ),  $x$  is equal to  $y$  multiplied by a constant  $k$ .

**295.** One quantity or number varies *inversely* as another when it varies as the reciprocal of the other. Thus, the time required to do a certain piece of work varies inversely as the number of men employed in doing it.

In  $x \propto \frac{1}{y}$ , if the constant ratio of  $x$  to  $\frac{1}{y}$  is  $k$ ,

$$\frac{x}{\frac{1}{y}} = k, \text{ or } xy = k, \text{ or } x = \frac{k}{y}$$

**296.** One quantity or number varies *jointly* as two others when it varies as their product.

In  $x \propto yz$ , if the constant ratio of  $x$  to  $yz$  is  $k$ ,

$$\frac{x}{yz} = k, \text{ or } x = kyz.$$

**297.** One quantity or number varies *directly* as a *second*, and *inversely* as a *third*, when it varies *jointly* as the second and the *reciprocal* of the third.

In  $x \propto y \cdot \frac{1}{z}$  or  $x \propto \frac{y}{z}$ , if  $k$  is the constant ratio,

$$x \div \frac{y}{z} = k, \text{ or } x = k \frac{y}{z}.$$

Thus the time required to dig a ditch varies directly as the length of the ditch and inversely as the number of men employed in digging it. For, if the ditch were ten times as long and five times as many men were employed in digging it, the time would be twice as great.

If  $x$  varies as  $y$  when  $z$  is constant, and  $x$  varies as  $z$  when  $y$  is constant, then  $x$  varies as  $yz$  when both  $y$  and  $z$  are variables.

Similarly, if  $x$  varies as each of three or more quantities when the others are constant, when all vary,  $x$  varies as their product.

$$x \propto yzv.$$

### 298. Problems.

**EXAMPLE 1.**—If  $x$  varies inversely as  $y$ , and  $x = 6$  when  $y = 8$ , what is the value of  $x$  when  $y = 12$ ?

Since  $x \propto \frac{1}{y}$ , let  $k$  be the constant ratio of  $x$  to  $\frac{1}{y}$ .

Then  $xy = k$ .

Hence, when  $x = 6$  and  $y = 8$ ,

$$k = 6 \times 8 = 48.$$

Since  $k$  is constant, it equals 48 when  $y = 12$ .

Substituting in  $xy = k$ ,

$$x \cdot 12 = 48.$$

$$x = 4.$$

**EXAMPLE 2.**—If  $x \propto y$  and  $y \propto z$ , prove that  $x \propto z$ .

Let  $m$  represent the constant ratio of  $x$  to  $y$ , and  $n$  the constant ratio of  $y$  to  $z$ .

$$\text{Then} \qquad x = my. \qquad (1)$$

$$\text{And} \qquad y = nz. \qquad (2)$$

Substituting  $nz$  for  $y$  in (1),  $x = mnz$ .

Hence, since  $mn$  is constant,

$$x \propto z.$$

**EXAMPLE 3.**—The volume of a cone varies jointly as the altitude and the square of the diameter of the base. When the altitude is 15 and the diameter of the base is 10, the volume is 392.7.

What is the volume when the altitude is 5 and the diameter of the base is 20?

Let  $V$ ,  $H$ , and  $D$  denote the volume, the altitude, and the diameter of the base, respectively, of any cone, and  $V'$  the volume of a cone whose altitude is 5 and the diameter of whose base is 20.

Since  $V \propto HD^2$ , or  $V = kHD^2$ ,

and  $V = 392.7$ , when  $H = 15$  and  $D = 10$ ,

$$392.7 = k \cdot 15 \cdot 100. \qquad (1)$$

Also, since  $V$  becomes  $V'$ , when  $H = 5$  and  $D = 20$ ,

$$V' = k \cdot 5 \cdot 400. \qquad (2)$$

Dividing (2) by (1),

$$\frac{V'}{392.7} = \frac{5 \cdot 400}{15 \cdot 100} = \frac{4}{3}$$

$$\therefore V' = \frac{4}{3}(392.7) = 523.6.$$

## CHAPTER XIII

### PROGRESSIONS

**299. Series.**—A series is a succession of terms so related that each may be derived from one or more of the preceding terms in accordance with some fixed law.

**300. Arithmetic Progression (A.P.).**—An arithmetic progression is a series, each term of which, except the first, is derived from the preceding term by the addition of a constant number. The common difference is the number which, added to each term, produces the next term.

[69]  $(a), (a + d), (a + 2d), (a + 3d), \dots$

This is an arithmetic progression in which  $a$  is the first term and  $d$  is the common difference.

If  $a = 3$  and  $d = 4$ , the series,

$$3, 7, 11, 15, 19, \dots$$

would be ascending.

If  $a = 17$  and  $d = -7$ , the series,

$$17, 10, 3, -4, -11, \dots$$

would be descending.

Since  $d$  is added to each term to obtain the next term,

$2d$  is added to  $a$  to form the third term.

$3d$  is added to  $a$  to form the fourth term.

$(n - 1)d$  is added to  $a$  to form the  $n$ th term.

Hence,

[70] the last, or  $n$ th, term is  $a + (n - 1)d$ , or  $l$ .

**301. To find the sum,  $S$ ,** of the first  $n$  terms of an A.P., take

$$S = a + (a + d) + (a + 2d) + \dots + (l - d) + l.$$

Reversing the order,

$$S = l + (l - d) + \dots + (a + 2d) + (a + d) + a.$$

Adding,

$$2S = (a + l) + (a + l) + (a + l) + \dots + (a + l)$$

or

$$2S = n(a + l).$$

**302.** From the foregoing,

$$[71] \quad S = \frac{n}{2} (a + l),$$

where  $n$  is the number of the last term  $l$ .

Since  $l = a + (n - 1)d$ , substituting gives

$$S = \frac{n}{2} [a + (a + \{n - 1\}d)], \text{ or}$$

$$[72] \quad S = \frac{n}{2} [2a + (n - 1)d].$$

**303.** In most A.P. problems, five quantities,  $a$ ,  $d$ ,  $n$ ,  $l$ , and  $S$ , are involved. If any three are given, the remaining two may be found by use of the simultaneous equations,

$$l = a + (n - 1)d, \text{ and } [70]$$

$$S = \frac{n}{2} (a + l) [71]$$

For convenience, we will put the series in the following form,

$$[73] \quad a + (a + d) + (a + 2d) + \dots + [a + (n - 1)d] = \frac{n}{2} [2a + (n - 1)d].$$

When three numbers are in A.P., the second or middle number is called the *arithmetic mean*.

Let the series be  $a$ ,  $x$ ,  $b$ .

Since their common difference must be the same,

$$x - a = b - x.$$

Solving,

$$[74] \quad x = \frac{a + b}{2} = \text{the arithmetic mean.}$$

**304. Graph of Arithmetic Progression.**—Since the series is made by adding the common difference each time, and  $a$  is the magnitude of the first term, the series,

$$a + (a + d) + (a + 2d) + \dots + [a + (n - 1)d] [73]$$

can be represented graphically if we let the ordinates represent the magnitude of the terms and the abscissae represent the number of the terms. The arithmetic progression will be represented by points whose abscissae are integers and which lie on a straight line whose slope is  $d$ , when the ordinate through the point 1 on the  $X$ -axis represents the magnitude of the first term.

Any term, such as the sixth, which is represented by the ordinate  $AB$ , can be found from the graph.

The sum of the series can be considered as the sum of  $n$  ordinates  $a$  units long each, plus the sum of the short ordinates in the triangular area at the top (Fig. 113).

Now we can consider all of these ordinates as forming another rectangle that is formed by  $n$  ordinates whose length is one-half of the length  $(n - 1)d$ . This will be apparent from the figure. It will be readily seen that the sum of the ordinates included in

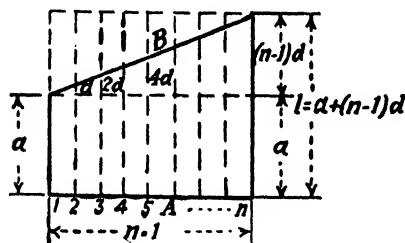

FIG. 113.

the triangle will be equal to one-half of the sum of  $n$  ordinates whose length is the length of the longest ordinate in the triangle, or

$$\frac{n(n-1)d}{2}$$

Then the sum of all of the terms is

Sum = Sum of the ordinates of the lower rectangle +

$$\text{Sum of the ordinates of the triangle} = na + \frac{n(n-1)d}{2} =$$

$$\frac{2na + n(n-1)d}{2} = \frac{n}{2}[2a + (n-1)d],$$

which agrees with the expression obtained by the analytical method.

From the graph, the value of any term or the sum of any number of terms can be quickly found by scaling the ordinates and adding them together.

**305. Some Arithmetical Series.**—Starting with the general form [73],

$$a + (a + d) + (a + 2d) + \dots + [a + (n - 1)d] = \frac{n}{2}[2a + (n - 1)d],$$

we develop the series according to the above expression by adding  $d$  to each term to obtain the succeeding term; that is, the fourth term is formed by adding the common difference to the third term, which in turn has been formed by adding the common difference to the second term. The second term is formed from the initial term by adding the common difference  $d$  to the initial term. The fifth term is, of course, formed by the addition of the fourth term and  $d$ , the sixth by the addition of the fifth and  $d$  and



so on until the  $n$  terms have been formed. The sum of the series is obtained from a substitution in the formula,

$$S = \frac{n}{2} [2a + (n - 1)d] \text{ [72].}$$

The manner of forming these series and making the substitution will be shown in the following examples.

**EXAMPLE.**—Develop a series for  $a = 1, d = 1$ .

$$a = 1 = \text{first term.}$$

$$a + d = 1 + 1 = 2 = \text{second term.}$$

$$2 + d = 2 + 1 = 3 = \text{third term.}$$

$$3 + d = 3 + 1 = 4 = \text{fourth term.}$$

$$4 + d = 4 + 1 = 5 = \text{fifth term.}$$

$$\text{Last term} = 1 + (n - 1) \cdot 1 = n.$$

Writing the series,

$$1 + 2 + 3 + 4 + 5 + \dots + (n - 1) + n.$$

The sum of the  $n$  terms is

$$\frac{n}{2} [2 \cdot 1 + (n - 1) \cdot 1] = \frac{n(n + 1)}{2} = \frac{n^2 + n}{2},$$

so that

$$1 + 2 + 3 + 4 + 5 + \dots + (n - 1) + n = \frac{n^2 + n}{2}.$$

**306. EXAMPLE.**—Develop an arithmetical series for  $a = 2, d = 3$ .

$$a = 2 = \text{first term.}$$

$$a + d = 2 + 3 = 5 = \text{second term.}$$

$$5 + d = 5 + 3 = 8 = \text{third term.}$$

$$8 + d = 8 + 3 = 11 = \text{fourth term.}$$

$$\text{Last term} = 2 + (n - 1) \cdot 3 = 3n - 1.$$

The sum of the  $n$  terms is

$$\frac{n}{2} [2 \cdot 2 + (n - 1)3] = \frac{n}{2} (3n + 1) = \frac{3n^2 + n}{2}.$$

Writing the series,

$$2 + 5 + 8 + 11 + 14 + 17 + \dots + 3n - 1 = \frac{3n^2 + n}{2}.$$

**EXAMPLE.**—Form the series for which  $a = p$  and  $d = 1$ .

The series becomes

$$p + (p + 1) + (p + 2) + (p + 3) + \dots + (q - 1) + q = \frac{(q + p)(q - p + 1)}{2},$$

because  $q = p + (n - 1) \cdot 1$ .

$$n = q - p + 1.$$

Substituting value of  $n$  in  $S = \frac{n}{2} [2a + (n - 1)d]$ ,

$$[75] S = \frac{q - p + 1}{2} [2p + (q - p + 1) - 1] = \frac{(p + q)(q - p + 1)}{2}.$$

**307.** Given the series,

$$2 + 4 + 6 + 8 + 10 + 12 + \dots$$

we desire to find a formula that will give a value for the  $n$ th term and one that will give a value for the sum of  $n$  terms.

Assuming that the progression is an arithmetic one, since the terms have a common difference, we may find any term, as the fifth, by letting  $n = 5$ , in  $a + (n - 1)d$ , where  $a = 2$ , and  $d = 2$ , thus,

$$2 + (5 - 1)2 = 10.$$

The value of the last term =  $2 + (n - 1) \cdot 2 = 2n$ .

The sum  $S$  of all of these terms is

$$S = \frac{n}{2} [4 + (n - 1) \cdot 2] = n(n + 1).$$

The series can then be written,

$$2 + 4 + 6 + 8 + 10 + 12 + \dots + (2n - 2) + 2n = n(n + 1).$$

**308.** The series of odd numbers would be

$$1 + 3 + 5 + 7 + 9 + 11 + \dots + (2n - 3) + (2n - 1) = n^2.$$

We can, therefore, build a table of squares from this law, using a registering adding machine to make it.

First	term =	1 = (1) <sup>2</sup>	$n = 1$
Second	term =	3	
	Sum =	4 = (2) <sup>2</sup>	$n = 2$
Third	term =	5	
	Sum =	9 = (3) <sup>2</sup>	$n = 3$
Fourth	term =	7	
	Sum =	16 = (4) <sup>2</sup>	$n = 4$
Fifth	term =	9	
	Sum =	25 = (5) <sup>2</sup>	$n = 5$
Sixth	term =	11	
	Sum =	36 = (6) <sup>2</sup>	$n = 6$
Seventh	term =	13	
	Sum =	49 = (7) <sup>2</sup>	$n = 7$
Eighth	term =	15	
	Sum =	64 = (8) <sup>2</sup>	$n = 8$

Ninth term = 17  
 Sum = 81 = (9)<sup>2</sup>    n = 9  
 Tenth term = 19  
 Sum = 100 = (10)<sup>2</sup>    n = 10

**309. Geometric Progression.**—A geometric progression is a series of terms, each of which, except the first, is derived from the term preceding, by multiplying it by a constant called the *ratio*. Thus,

$$4, 12, 36, 108 \quad (\text{ratio} = 3).$$

$$4, -2, +1, -\frac{1}{2} \quad (\text{ratio} = -\frac{1}{2}).$$

$$a, ar, ar^2, ar^3 \quad (\text{ratio} = r).$$

To find the *n*th term of G.P., with the first term *a* and ratio *r*, we start with

[76]  $a, ar, ar^2, ar^3, ar^4, \text{ etc.},$

and note that *a* is multiplied by *r*<sup>*n*-1</sup> for each term where *n* is the number of the term. Therefore, the last term, which we will call *l*, is *ar*<sup>*n*-1</sup>.

[77]  $l = ar^{n-1}.$

**310.** To find the sum *S* of the first *n* terms of a G.P., we start with

$$S = a + ar + ar^2 + ar^3 + \dots + ar^{n-1}. \quad (1)$$

Multiplying by *r*,

$$rS = ar + ar^2 + ar^3 + ar^4 + \dots + ar^n. \quad (2)$$

Subtracting (1) from (2),

$$S(r - 1) = ar^n - a, \text{ or}$$

[78]  $S = \frac{ar^n - a}{r - 1} = a \left( \frac{r^n - 1}{r - 1} \right).$

**311.** In most problems relating to geometrical progressions, the five quantities, *a*, *r*, *n*, *l*, and *S*, are involved. Hence, if any three of the five are given, the other two may be found by the solution of the simultaneous equations,

$$l = ar^{n-1} \text{ and [77]}$$

$$S = a \left( \frac{r^n - 1}{r - 1} \right). \quad \text{[78].}$$

**312. Geometric Mean.**—The geometric mean between two numbers is equal to the square root of their product, or to  $\sqrt{ab}$ , if *a* and *b* are the numbers.

Let  $G$  equal their geometric mean. Then from our definition of a geometrical progression, we have the ratios,

$$\frac{G}{a} = \frac{b}{G},$$

$$G^2 = ab, \text{ and}$$

$$[79] \quad G = \sqrt{ab}.$$

To insert, say five terms between 9 and 576, so that the terms form a G.P.,

$$5 + 2 = 7 = \text{total number of terms.}$$

Substituting in [77],

$$576 = 9r^6.$$

$$r^6 = 64.$$

$$r = \pm 2.$$

Therefore, the series is

$$9, 18, 36, 72, 144, 288, 576, \text{ or}$$

$$9, -18, 36, -72, 144, -288, 576.$$

**313. Infinite Geometrical Progression.**—If the ratio  $r$  of a G.P. is less than unity, the value of  $r^n$  decreases as  $n$  increases.

The formula for the sum [78] may be written,

$$[80] \quad S = \frac{a - ar^n}{1 - r} = \frac{a}{1 - r} - \frac{ar^n}{1 - r}.$$

By taking  $n$  sufficiently large,  $r^n$  and, hence,  $\frac{ar^n}{1 - r}$  may be made less than any assignable number. Consequently, by taking a sufficiently large number of terms,  $S$  can be made to differ from  $\frac{a}{1 - r}$  by less than any given number, however small.

This is usually expressed,

$$[81] \quad S_{n \rightarrow \infty} = \frac{a}{1 - r}.$$

It is the limit of the sum of a G.P., with  $r$  less than 1, for an infinite number of terms.

**314. Some Geometric Series.**—The general expression for series of this type is

$$a + ar + ar^2 + ar^3 + \dots + ar^{n-1} = \frac{a}{1 - r} - \frac{ar^n}{1 - r}.$$

Next in importance is

$$a + \frac{a}{2} + \frac{a}{2^2} + \frac{a}{2^3} + \frac{a}{2^4} + \dots + \frac{a}{2^{n-1}} = 2a - \frac{a}{2^{n-1}}.$$

The limit of the sum of this series is

$$S \infty = 2a.$$

**315. Combined Arithmetical and Geometrical Progression.—**

A series partly arithmetical and partly geometrical is represented by

[82]  $a, (a + d)r, (a + 2d)r^2, (a + 3d)r^3, \text{ etc.}$

The sum of the first  $n$  terms in this series is

[83] 
$$S = \frac{a - [a + (n - 1)d]r^n}{1 - r} + \frac{rd(1 - r^{n-1})}{(1 - r)^2}.$$

**316. Graphical Representation of G.P.—**We can consider the first term of G.P. as unity, since  $a$  occurs as a constant multiplier in each term.

Assume, then, the series,

$$1 + r + r^2 + r^3 + \dots + r^{n-1}.$$

Take  $OM = 1, r > 1$ .

$$OS_1 = 1.$$

$$S_1P_1 = r.$$

Draw  $MP_1$  prolonged.

With  $S_1$  as a center and  $SP_1$  as a radius, draw the arc  $P_1S_2$ , locating the point  $S_2$ , and at this point erect the perpendicular  $S_2P_2$ , thus locating the point  $P_2$ . With  $S_2$  as a center and  $S_2P_2$  as a radius, draw the arc  $P_2S_3$ . Continue in this manner to  $P_nS_n$ .

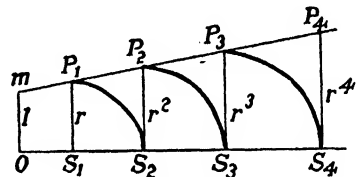

FIG. 114.

The slope of  $MP_1 = -(1 - r)$ .

$$OM = OS_1 = 1.$$

$$P_1S_1 = S_1S_2 = r. \therefore OS_2 = 1 + r = \text{sum of two terms.}$$

$$P_2S_2 = S_2S_3 = r^2. \therefore OS_3 = 1 + r + r^2 = \text{sum of three terms.}$$

$P_3S_3 = S_3S_4 = r^3. \therefore OS_4 = 1 + r + r^2 + r^3 = \text{sum of four terms.}$  In general,

$$P_{n-1}S_{n-1} = S_{n-1}S_n = r^{n-1}.$$

$$\therefore OS_n = 1 + r + r^2 + r^3 + r^4 + \dots + r^{n-1} = \text{sum of } n \text{ terms.}$$

**317. In the Case Where  $r < 1$ .—**In this case, proceed as before.

The slope of  $MP_1P_2$  etc., is  $(r - 1)$ .

The equation of  $MP_1P_2$  etc., in both cases is

$$y = (r - 1)x + 1, \text{ or}$$

$$x = \frac{1 - y}{1 - r}.$$

In this last, or converging series, if we let the number of terms increase without limit, the sum  $OS_n$  approaches  $OL$  as a limit. This gives us a graphical method of finding the limit. Simply get the slope of  $MP_1$  and note the intersection on  $OL$ .  $OL$  is the

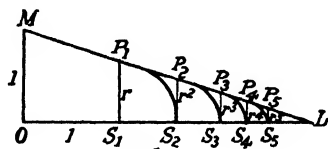

FIG. 115.

value of  $x$  when  $y = 0$ . Hence, the limit of the sum of the series is  $OL$ , or

$$\frac{1}{1 - r}$$

318. Since we developed the series with the first term equal to unity, we can find the sum of the series which has its first term equal to  $a$ , by multiplying the length of  $OS_n$ , or  $x$ , by  $a$ . Our limit also becomes

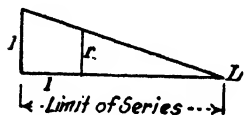

FIG. 116.

$$\frac{a}{1 - r}$$

in the last case, and for the series,

$$a + ar + ar^2 + ar^3 + ar^4 + \dots + ar^{n-1},$$

we multiply the value of  $x$ , or  $OL$  by  $a$ .

319. **Harmonical Progression.**—The terms,  $a, b, c$ , etc., form a harmonical series if their reciprocals,

$$\frac{1}{a}, \frac{1}{b}, \frac{1}{c}, \text{ etc.},$$

form an arithmetical series. Thus,

$$3, \frac{3}{2}, 1, \frac{2}{3}, \frac{3}{4}, \frac{1}{2}, \dots \text{ is a harmonical progression,}$$

because

$\frac{1}{3}, \frac{2}{3}, 1, \frac{4}{3}, \frac{3}{2}, 2, \dots$ , the reciprocals, form an arithmetical series.

Harmonical series are usually solved by taking the reciprocals and solving the arithmetical series. There is no general method of getting the sum of the terms.

320. **Harmonical Mean.**—The harmonical mean between two numbers is equal to twice their product divided by their sum, or

$$[84] \quad H = \frac{2ab}{a + b}$$

Let  $a$  and  $b$  be the two numbers and  $H$ , the harmonic mean.  
By definition, we have

$$\frac{1}{a} + \frac{1}{H} + \frac{1}{b}$$

Hence,

$$\begin{aligned} \frac{1}{b} - \frac{1}{H} &= \frac{1}{H} - \frac{1}{a} \\ aH - ab &= ab - bH \\ aH + bH &= 2ab \\ H &= \frac{2ab}{a+b} \end{aligned}$$

**321.** The geometrical mean between two numbers is also the geometrical mean between their arithmetical and harmonic means.

$$A = \frac{a+b}{2} \tag{1}$$

$$G = \sqrt{ab} \tag{2}$$

$$H = \frac{2ab}{a+b} \tag{3}$$

Multiplying (1) by (3),

$$AH = ab.$$

Taking the square root,

$$\sqrt{AH} = \sqrt{ab}.$$

But  $G = \sqrt{ab}$ , from (2).

$\therefore G = \sqrt{AH}$  = geometrical mean between the arithmetical and harmonic means of  $a$  and  $b$ .

If  $a$  and  $b$  are the first and second terms of a harmonic series, the  $n$ th term of a harmonical series is

$$[85] \quad l = \frac{ab}{(n-1)a - (n-2)b}$$

Any series whose terms are formed according to this law is a harmonical series.

**322.** The relation between the harmonic and the arithmetical progressions can be shown, graphically, as follows:

Draw a unit square  $ABOE$ .

Lay off the terms of the harmonic series, which in this case we have taken to be

$$3, 1\frac{1}{2}, 1, \frac{3}{4}, \frac{3}{8}, \frac{1}{2}, \text{etc.},$$

on  $OE$  measuring from  $O$ , each time.

Draw lines from  $A$  through the points,

$$3, \frac{3}{2}, 1, \frac{1}{2}, \text{etc.},$$

of the harmonical series, intersecting the vertical line  $BH$ .

The distances  $BC, BE, BF$ , etc. represent the terms of the reciprocal arithmetical progression with the common difference a constant. This means that  $BC, CD, DE$ , etc., are all equal. If the points  $B, C, D, E$ , etc. are not equally spaced, the series is not harmonical.

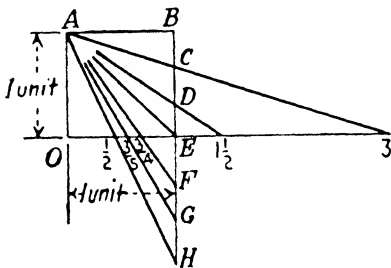

FIG. 117.

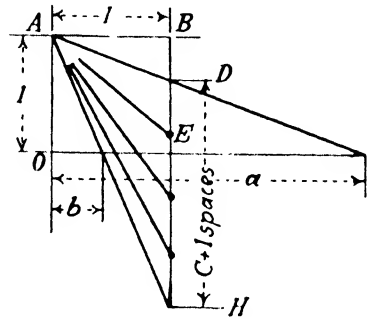

FIG. 118.

**323.** To build up graphically a harmonical series, when two terms are given, say  $a$  and  $b$ , and there are to be  $c$  numbers of intermediate terms, it is only necessary to lay off the space between the  $a$  and  $b$  reciprocal values on the vertical scale  $DH$  into  $c + 1$  equal parts, and draw the lines from these points to  $A$ , and locate their intersections on  $OEa$ .

The harmonical mean between two numbers can be found in the same manner by taking the midpoint of  $DH$  (Fig. 118), drawing a line from that point to  $A$ , and locating its intersection with  $OE$ .



## CHAPTER XIV

### VARIABLES, LIMITS, AND INDETERMINATE FORMS

**324. Limit of a Variable.**—Where a variable takes a series of values that approach nearer and nearer to a given constant so that by taking a sufficient number of steps, the difference between the variable and the constant can be made numerically less than any preassigned number, however small, the constant is called the *limit* of the variable, and the variable is said to approach this constant as a limit.

The variable, .3, .33, .333, . . . , whose increase is  $\frac{1}{10}$  of its previous increase, approaches  $\frac{1}{3}$  as a limit.

.3 differs from  $\frac{1}{3}$  by less than  $\frac{1}{10}$ .

.33 differs from  $\frac{1}{3}$  by less than  $\frac{1}{100}$ .

.333 differs from  $\frac{1}{3}$  by less than  $\frac{1}{1000}$ .

By continuing in this manner, taking a sufficient number of terms, the difference between the variable and  $\frac{1}{3}$  can be made smaller than any number, however small, whose value has been preassigned. That is, the difference approaches zero as a limit or the difference is an infinitesimal.

**325.** A variable, such as the one that takes the successive values, 6.6, 6.66, 6.666, . . . may come nearer in value to some number which is not its limit. Thus, the limit in this case is  $6\frac{2}{3}$ ; yet the value of the variable comes closer and closer to 7, which, however, cannot be its limit since it is not possible to make the difference between the variable and 7 become and remain less than any preassigned number. This difference will always remain greater than  $\frac{1}{3}$  regardless of the number of terms taken.

**326.** The variable may approach its limit and always remain greater than its limit, it may approach its limit and always remain less than its limit, or it may approach the limit, being sometimes greater and sometimes less than its limit. The important thing is that the *difference* between the variable and its limit *ultimately becomes and remains* less than any preassigned number, however small.

**327.** A variable may change in such a way as to become greater than or less than any preassigned positive number. If greater, the variable is said to become infinite or to increase without bound. This fact of the variable  $x$ , increasing beyond bound or becoming infinite is denoted by the symbol  $x \rightarrow \infty$ . If the variable  $x$  ultimately becomes and remains less than any preassigned positive number, however small, it is said to approach zero as a limit and is called an infinitesimal. This is denoted by the symbol  $x \rightarrow 0$ .

**328.**

$$\frac{a}{x} \rightarrow \infty \quad |x \rightarrow 0|.$$

If a constant finite number is divided by an infinitesimal, the quotient will become infinite. That is, if the numerator of a fraction  $\frac{a}{x}$  is constant, while the denominator decreases so that ultimately it may be made to become and remain less than any preassigned number (that is, numerically less), the quotient will increase and may be made to become and remain greater than any preassigned number, however great.

**329.**

$$\frac{a}{x} \rightarrow 0 \quad |x \rightarrow \infty|.$$

If a constant finite number is divided by a variable which increases beyond bound, the quotient will be an infinitesimal. That is, if the numerator of a fraction  $\frac{a}{x}$  is constant, while the denominator is becoming infinite, the quotient will decrease and approach zero.

**330.** A variable cannot approach two unequal limits at the same time.

**331.** If two variables are always equal and each approaches a limit, their limits are equal.

**332.** The limit of the algebraic sum of a constant and a variable is the algebraic sum of the constant and the limit of the variable.

**333.** The limit of the product of a variable and a finite constant is equal to the product of the constant and the limit of the variable.

**334.** The limit of the variable sum of any finite number of variables is equal to the sum of their limits.

**335.** The limit of the variable product of two or more variables is equal to the product of their limits.

**336.** The limit of the quotient of two variables is equal to the quotient of their limits, provided that the limit of the divisor is not zero.

**337.** The expression,

$$\text{Limit [function of } x] \text{ } x \rightarrow a,$$

is read, "limit of function of  $x$ , as  $x$  approaches  $a$  as a limit."

In function,

$$4x - 3y,$$

if Limit  $x = 5$  and Limit  $y = 2$ ,

$$\text{Limit of function of } x \text{ and } y = 4 \cdot 5 - 3 \cdot 2 = 14.$$

$$\text{Limit} \left[ \frac{x^2 - 1}{x - 1} \right]_{x \rightarrow 1}.$$

We note that direct substitution in the function above gives

$$\frac{1 - 1}{1 - 1} = \frac{0}{0}, \text{ which is an indeterminate form,}$$

but if we first factor the expression,

$$\frac{x^2 - 1}{x - 1} = \frac{(x + 1)(x - 1)}{x - 1} = x + 1.$$

Since  $x \rightarrow 1$ , we have

$$\text{Limit} \left[ \frac{x^2 - 1}{x - 1} \right]_{x \rightarrow 1} = 1 + 1 = 2,$$

or the expression approaches 2 as a limit as  $x$  approaches 1.

Find the limit of

$$\left[ \frac{4x^3 - 2x + 1}{2x^3 - 3x^2 + 4} \right]_{x \rightarrow \infty}.$$

Direct substitution gives  $\frac{\infty}{\infty}$ , but by dividing numerator and denominator by  $x^3$ , we get

$$\text{Limit} \left[ \frac{4 - \frac{2}{x^2} + \frac{1}{x^3}}{2 - \frac{3}{x} + \frac{4}{x^3}} \right]_{x \rightarrow \infty}.$$

As  $x \rightarrow \infty$ ,  $\frac{2}{x^2}$ ,  $\frac{1}{x^3}$ ,  $\frac{3}{x}$ ,  $\frac{4}{x^3}$ , all approach zero as a limit. The expression, therefore, approaches 2 as a limit.

Find the limit of

$$\left[ \frac{x^2}{2x-4} - \frac{3x-4}{x-2} \right]_{x \rightarrow 2}$$

Direct substitution gives  $\infty - \infty$ .

Simplifying gives

$$\frac{x^2 - 6x + 8}{2(x-2)} = \frac{x-4}{2}$$

$$\text{Limit} \left[ \frac{x-4}{2} \right]_{x \rightarrow 2} = -\frac{2}{2} = -1.$$

### 338. Other Methods.

$$\left[ \frac{4x^3 - 2x^2 + 3x + 1}{3x^3 - x^2 + x + 2} \right]_{x \rightarrow 0}$$

As  $x$  approaches 0, the first three terms of the numerator and the first three terms of the denominator approach zero. Hence, by Art. 326 the numerator  $\rightarrow 1$  and the denominator  $\rightarrow 2$ ; and then by Art. 328 the fraction approaches the limiting value  $\frac{1}{2}$ .

**339.** If the numerator of the fraction  $\frac{a}{x}$  is constant, while the denominator increases in such a way as to become numerically greater than any preassigned number, the quotient will decrease regularly and become numerically smaller than any assignable number.

**340. The Indeterminate Form.**—If the results of operations with limits and variables reduce to

$$\infty - \infty, 0 \times \infty, \infty \times 0, \frac{0}{0}, \frac{\infty}{0}, 0^0, \infty^0, 1^\infty, \text{ they are indeterminate.}$$

A limit will often take one of these forms by direct substitution.

If the quantity is in the form of a fraction, the first operation should be to reduce it to its lowest terms.

The sign  $\rightarrow$  or  $\doteq$  means *approaches as a limit*.

When, by causing a variable  $x$  to approach sufficiently near to its limit  $a$ , it is possible to make the value of a given function of  $x$  approach as near as we please to a finite constant  $l$ ,  $l$  is called the limit of the function, when  $x \rightarrow a$ , or when  $x$  approaches  $a$ .

As  $x \rightarrow \infty$ , that is, as  $x$  becomes infinitely great, the last three terms of the numerator and the last three terms of the denominator (Art. 338) become infinitely small as compared with the first

and can consequently be neglected. Hence, when  $x \rightarrow \alpha$ , the fraction approaches the limiting value,

$$\frac{4x^3}{3x^3} = \frac{4}{3}$$

EXAMPLE.—Find the limiting value of

$$\left[ \frac{f(x+h) - f(x)}{h} \right]_{h \rightarrow 0}, \text{ if } f(x) = x^3.$$

$$\frac{(x+h)^3 - x^3}{h} = \frac{3x^2h + 3xh^2 + h^3}{h} = 3x^2 + 3xh^2 + h^3.$$

Hence,

$$\left[ \frac{(x+h)^3 - x^3}{h} \right]_{h \rightarrow 0} = 3x^2.$$

## CHAPTER XV

### LOGARITHMS

**341. John Napier** (1550–1617) found, by comparing arithmetical and geometrical progressions, that a relation existed between the two series that has since developed into an exceedingly useful aid to calculation.

Take, for example, the geometrical progression (G.P.) and the arithmetical progression (A.P.) shown in the table below, where the first term of the arithmetical progression is 0 and the first term of the geometrical progression is 1.

<i>G.P.</i>	1	2	4	8	16	32	64	128	256	512	1024
<i>A.P.</i>	0	1	2	3	4	5	6	7	8	9	10

The product of any two terms of the G.P. may be found by adding the terms of the A.P. directly below these terms, and opposite the term of the A.P., which is indicated by the sum, is found the term of the G.P. which gives the answer. Thus, the product of 8 and 32 is found by adding 3 and 5, the numbers immediately under 8 and 32, and opposite their sum 8 in the arithmetical series is the number 256 in the geometrical series which is the product.

It will be noted that in this particular G.P., the ratio of the terms is 2 and that the series is

$$2^0, 2^1, 2^2, 2^3, 2^4, 2^5, 2^6, 2^7, 2^8, 2^9, 2^{10}, \dots$$

The exponents correspond to the A.P. terms. The number 2 forms the base of the system, and the exponents or the A.P. terms are called the logarithms of the numbers opposite them in the table above. Thus, the log of 16 to the base 2 is 4, or as it is written,  $\log_2 16 = 4$ .

This particular illustrative series is not, however, adequate for the purpose of computing, since the products of numbers which do not appear in the series cannot be found, as the product of 68 and 250, for neither of these numbers is a term of the G.P.

Any number of series might be used, but all of them would have the gaps between the terms.

Napier established a particular base for his system and proceeded to divide the difference between 1 and 2 into 100 equal ratios by which he meant the insertion of 100 geometrical means between 1 and 2. Hence the word, "logarithm," from the Greek meaning "the number of the ratio."

**342.** These same series can also be extended to the left indefinitely, thus,

G.P.	$\frac{1}{2}$	$\frac{1}{4}$	$\frac{1}{8}$	$\frac{1}{16}$	$\frac{1}{32}$	1	2
A.P.	-5	-4	-3	-2	-1	0	1

The G.P. corresponding is

$$\frac{1}{2^5}, \frac{1}{2^4}, \frac{1}{2^3}, \frac{1}{2^2}, \frac{1}{2^1}, \frac{1}{2^0}, \text{ or } 2^{-5}, 2^{-4}, 2^{-3}, 2^{-2}, 2^{-1}, 2^0.$$

To build up a set of logs to correspond to numbers over a considerable range, and also the decimal quantities between two consecutive numbers, as 1 and 2, etc., requires finding the geometrical means between these quantities. If we insert one geometrical mean between the members of the last series,

$$\text{mean} = \sqrt{ab}, \text{ where } a \text{ and } b \text{ are the two numbers,}$$

then, the series would be

G.P.	$\frac{1}{4}$	$\frac{1}{4}\sqrt{2}$	$\frac{1}{2}$	$\frac{1}{2}\sqrt{2}$	1	$\sqrt{2}$	2	$2\sqrt{2}$
A.P.	-2	$-1\frac{1}{2}$	-1	$-\frac{1}{2}$	0	$\frac{1}{2}$	1	$\frac{3}{2}$

By repeating this process of inserting means, we can build up a log table.

Now, if we interpolate  $n$  arithmetical means, for example, between 0 and 1 in the A.P., and  $n$  geometrical means between 1 and 2 in the G.P., the series become

G.P.	$2^0$	$\frac{1}{2^n}$	$\frac{2}{2^n}$	$\frac{3}{2^n}$	.....	.....	.....	$\frac{n}{2^n}$	$\frac{n+1}{2^n}$
A.P.	0	$\frac{1}{n}$	$\frac{2}{n}$	$\frac{3}{n}$	.....	.....	.....	$\frac{n}{n}$	$\frac{n+1}{n}$

Continuing,

<i>G.P.</i>	$\frac{n+1}{2^n}$	$\frac{n+2}{2^n}$	$\frac{n+3}{2^n}$	.....	.....	.....	$\frac{n+n-1}{2^n}$	$\frac{2n}{2^n}$
<i>A.P.</i>	$\frac{n+1}{n}$	$\frac{n+2}{n}$	$\frac{n+3}{n}$	.....	.....	.....	$\frac{n+n-1}{n}$	$\frac{2n}{n}$

**343.** The logarithm of a number, to a given base, then, is the exponent by which the base must be affected in order that the result may equal the number.

Thus, if

$$a^x = N,$$

$x$  is the logarithm to the base  $a$  of the number  $N$ . We indicate this by writing

$$x = \log_a N$$

The base  $a$  may be any positive number except 1 or 0.

The two systems of logarithms in common use are the Napierian, or natural, where the base  $e = 2.71828 \dots$ , and the common, or Briggs, where the base is 10.

The Napierian system is used in higher mathematics, because the slope of the exponential curve at any point is equal to the ordinate at that point.

The basis of the differential calculus is the slope of the tangent to a curve at any point, and if this slope is equal to  $y$  or the function itself, the work of differentiating is very simple.

For numerical calculation, the Briggs, or common, system, with base = 10, is better for, by inserting a sufficient number of geometrical means between 1 and 10, the complete numerical field is covered.

The following relations of numbers hold regardless of the base used:

$$\log(ab) = \log a + \log b. \quad \log\left(\frac{a}{b}\right) = \log a - \log b.$$

$$\log\left(\frac{1}{n}\right) = -\log n. \quad \log a^n = n \log a. \quad \log \sqrt[n]{a} = \frac{1}{n} \log a.$$

$$\log \text{base} = 1. \quad \log 1 = 0.$$

We will now build a limited table of the two systems so that we can establish relations between them.



Napierian System		Briggs System	
A.P.	G.P.	A.P.	G.P.
-3	$\frac{1}{e^3} = e^{-3} = 00.04979$	-3	$\frac{1}{10^3} = 10^{-3} = .001$
-2	$\frac{1}{e^2} = e^{-2} = 00.13534$	-2	$\frac{1}{10^2} = 10^{-2} = .01$
-1	$\frac{1}{e^1} = e^{-1} = 00.3678$	-1	$\frac{1}{10^1} = 10^{-1} = .1$
0	$e^0 = 01.00000$	0	$10^0 = 1.$
1	$e^1 = 02.71828$	1	$10^1 = 10.$
2	$e^2 = 07.389$	2	$10^2 = 100.$
3	$e^3 = 20.085$	3	$10^3 = 1000.$
4	$e^4 = 54.589$	4	$10^4 = 10,000.$

**344.** Considering the common system with base 10, by referring to the table just given, note that the logs are one less than the number of integers to the left of the decimal point for whole numbers, and one more than the number of ciphers to the left of the first significant figure for decimal numbers.

In this system, the mantissa, or decimal part of the log, does not change, when the decimal point is moved, thus,

$$10^2 \cdot 10^{.038} = 127^1, \text{ or } \log 127 = 2.1038.$$

$$10^1 \cdot 10^{.038} = 12.7, \text{ or } \log 12.7 = 1.1038.$$

$$10 \cdot 10^{.038} = 1.27, \text{ or } \log 1.27 = .1038.$$

The mantissa always remains positive and the negative sign of the log applies only to the whole number or the characteristic.

Since the log table is based on geometric ratios between 1 and 10, the logs are decimal numbers; that is, they consist of mantissa only and are usually so given in tables of logs.

Any number, as 2834, is the product of two factors, as

$$2.834 \times 10^3,$$

and according to fundamental principles,

$$\log 2.834 = .4524, \quad \log 10^3 = 3.0000.$$

Therefore,

$$\log 2834 = .4524 + 3.0000 = 3.4524.$$

Divide the number into two factors. Make the first factor the number with the decimal point directly after the first left-

<sup>1</sup> Found from log tables.

hand digit. If 2834 is the number, make the first factor 2.834 as shown. Make the second factor  $10^3$ , because the decimal point must be shifted three places to the right, or in a positive direction, to make 2.834 equal to 2834.

Then

$$2.834 \times 10^3 = 2834.$$

The logarithm of the first factor is found direct from any log table as it stands, since it is between 1 and 10, and the log tables are given for numbers between 1 and 10.

The logarithm of the second factor  $10^3$  is 3 or the characteristic of the logarithm of the product.

All that is necessary, then, is to write the first factor with the decimal point after the first digit on the left side and find the mantissa to correspond. Then write the second factor as 10 raised to a power equal to the number of decimal places that the decimal point must be moved to make the first factor equal to the number. The number of places shifted is the characteristic of the log.

To find the log .0002834:

As before,

$$\log .0002834 \text{ (.0002834 = } 2.834 \times 10^{-4}\text{) equals}$$

$$\log 2.834 + \log 10^{-4}.$$

$$\log 2.834 = .4524.$$

$$\log 10^{-4} = -4, \text{ or } \bar{4}.0000.$$

Therefore,

$$\log .0002834 = \bar{4}.4524, \text{ or } .4524 - 4.$$

This method of using logs should greatly simplify their use and no difficulty should be experienced in using them facilely if it is followed.

**345. Interpolation.**—It frequently happens that the usual four-place table does not give a log that is sufficiently accurate for the purpose, and a revision of the log given in the table is necessary.

For the number 283.4, the fourth significant figure 4 is  $\frac{4}{10}$  of the difference between 283.0 and 284.0, plus 283.0. The log tables have these differences tabulated with the tables, and referring to a log table, we find .

$$\log 283.0 \text{ is } 2.4518 \text{ with a difference of } 15.$$



we should have to look up this latter power and then perform a long division to get  $N$ .

To avoid such difficulties, be careful to keep the mantissa positive at every step of the calculation. This can be done by increasing the smaller logarithm by some integer, making it the larger, and at the same time indicating the subtraction of a like integer so as to keep the actual value unchanged as in the following example:

$$x = \frac{1.58}{4326}$$

$$\log x = \log 1.58 - \log 4326.$$

$$\log 1.58 = .19866.$$

$$\log 4326 = 3.63609.$$

Increase the first log by 4 with  $-4$  affixed, making

$$\log 1.58 = 4.19866 - 4$$

$$\log 4326 = 3.63609$$

$$\log x = .56257 - 4.$$

Look up the resulting positive mantissa and point off  $-4$ .

The number whose log is .56257 is 3.652, and moving the decimal point four places to the left gives

$$x = .0003652.$$

**348.** If the  $\log N = 3.4524$ , we know that the mantissa part of the log corresponds to some number between 1 and 10 and that the characteristic represents some power of 10, as  $10^3$  in the above instance. Then by finding the number corresponding to the mantissa, which here is 2.834, and shifting the decimal point three places to the right, we get the number sought, or 2834.

If the  $\log N = .4524 - 4$ , our characteristic is  $-4$  which represents  $10^{-4}$ , and we would shift the decimal point four places to the left from where it stands in 2.834, and the result gives  $N = .0002834$ , for the number.

### 349. Multiplication by Logarithms.

Find the log of each factor from the tables.

Add the logs of the factors and the result will be the log of the product.

Find from the tables the number that corresponds to this log. This number is the product.

EXAMPLE.

$$\begin{aligned}
 x &= (4.056)(92.1)(.0001832). \\
 \log 4.056 &= .6081. \\
 \log 92.1 &= 1.9643. \\
 \log .0001832 &= .2629 - 4 \\
 \hline
 \log x &= 2.8353 - 4 \text{ or } .8353 - 2. \\
 x &= 6.84 \times 10^{-2} = .0684.
 \end{aligned}$$

### 350. Division by Logarithms.

Subtract the log of the denominator from the log of the numerator and the result will be the log of the quotient.

Find the number which has this remainder for its log and this number will be the quotient.

Since, for illustration,

$$\begin{aligned}
 N &= \frac{2314}{141} = \frac{2314}{1} \times \frac{141^{-1}}{1}, \\
 \log N &= \log 2314 - \log 141. \\
 \log N &= 3.3643 - 2.1492 = 1.2151. \\
 N &= 16.41 \text{ (from table).}
 \end{aligned}$$

EXAMPLE.

$$\begin{aligned}
 N &= \frac{3.128}{.000168}; \\
 \log 3.128 &= .4953 \\
 \log .000168 &= .2253 - 4 \\
 \hline
 \log N &= .2700 + 4 = 4.2700. \\
 N &= 18620.
 \end{aligned}$$

If a larger mantissa is to be subtracted from a smaller one, we avoid negative mantissae by adding 1 to the characteristic and subtracting 1, thus in the case,

$$\begin{aligned}
 N &= \frac{.0333}{49.1} \quad \log .0333 = .5224 - 2 = 1.5224 - 3. \\
 \log 49.1 &= .6911 + 1 = .6911 + 1.
 \end{aligned}$$

After the logs have been thus transformed, we can easily subtract,

$$\begin{aligned}
 \log .0333 &= 1.5224 - 3 \\
 \log 49.1 &= .6911 + 1 \\
 \hline
 \log N &= .8213 - 4 \\
 N &= 6.62 \times 10^{-4} = .000662.
 \end{aligned}$$

The number  $N$ , corresponding to a given logarithm, is called its antilogarithm.

**351. Cologarithms.**—The remainder obtained by subtracting a logarithm from 1.0000 - 1 is called the cologarithm, or simply the colog of a number.

By means of cologarithms, combined multiplication and division can be changed into multiplication.

$$\text{colog } N = -\log N = \log \frac{1}{N}$$

$$\begin{aligned} \log .0734 &= \frac{1.0000 - 1}{.8657 - 2} \\ &= \frac{.1343 + 1}{.1343 + 1} = \text{colog } .0734. \end{aligned}$$

Again,

$$N = \frac{.0216 \times .831}{61.3 \times 4.12}$$

$$\log .0216 = .3345 - 2$$

$$\log .831 = .9196 - 1$$

$$\text{colog } 61.3 = .2125 - 2 \quad (\log 61.3 = .7875 + 1)$$

$$\text{colog } 4.12 = .3851 - 1 \quad (\log 4.12 = .6149)$$

$$\log N = 1.8517 - 6 = .8517 - 5.$$

$$N = 7.167 \times 10^{-5} = .00007167.$$

**352. To Find the Powers of Numbers by Logs.**—If a number  $a$  is raised to the  $n$ th power, we have

$$a^n = a \cdot a \cdot a \cdot a \cdot a \dots \text{etc., to } n \text{ factors.}$$

$$\log a^n = \log a + \log a + \log a + \dots \text{to } n \text{ terms.}$$

$$\therefore \log a^n = n \cdot \log a.$$

Therefore, we find from the table, the log of the number which it is desired to raise to the  $n$ th power, and multiply this log by  $n$ . The result will be the logarithm of the  $n$ th power of the given number. Then find the antilog of this product from the table and the result will be the  $n$ th power itself.

EXAMPLE.

$$N = (.033)^3.$$

$$\log .033 = .5185 - 2.$$

$$\log N = (.5185 - 2) \times 3 = 1.5555 - 6 = .5555 - 5.$$

$$N = 3.59 \times 10^{-5} = .0000359.$$

**353. To Find Fractional Powers by Logs.**

$$a^{\frac{m}{n}} = a \cdot a \cdot a \cdot a \cdot a \cdot a \dots \text{etc., to } \frac{m}{n} \text{ factors.}$$

$$\log a^{\frac{m}{n}} = \log a + \log a + \log a + \dots \text{to } \frac{m}{n} \text{ terms.}$$

$$\therefore \log a^{\frac{m}{n}} = \frac{m}{n} \cdot \log a.$$

EXAMPLE.

$$\sqrt[3]{(125)^3} = (125)^{\frac{3}{3}}$$

$$\log (125)^{\frac{3}{3}} = \frac{3}{3} \cdot \log 125 = \frac{3}{3}(2.0969) = 1.3979.$$

$$\text{antilog } 1.3979 = 25 \text{ (from table).}$$

### 354. Evolution.

If the  $n$ th root of a number is desired, consider the number as being raised to the  $\frac{1}{n}$ th power as in the following illustrative example.

$$\sqrt[3]{1728} = (1728)^{\frac{1}{3}}$$

$$\log (1728)^{\frac{1}{3}} = \frac{1}{3}(3.2375) = 1.0792.$$

$$\text{antilog } 1.0792 = 12 \text{ (from table).}$$

**355. To Find Reciprocals Using Logs.**—Subtract the mantissa of the log of the number from 1, add 1 to the characteristic, and change the sign.

EXAMPLE.—Find the reciprocal of 426.

$$\log 426 = 2.629410.$$

Subtracting,

$$1.000000$$

$$.629410$$

$$\hline .370590$$

Add 1 to the characteristic, which is 2, and change the sign.

Then

$$3.370590 \text{ is the log of } .002347.$$

**356. To Find the Fourth Term of a Proportion by Logs.**—Add the logs of the second and third terms, and from their sum, subtract the log of the first term. Then the number whose log is this result is the fourth term of the proportion.

**357. Natural or Naperian Logarithms.**—These are found from tables in the same manner as the common logs. The principal difference is that 2.3026 is added or subtracted from the log for each point that the decimal point is shifted to the right or left. By reference to the table Art. 343, the log of 10 in this system is seen to be 2.3026.

The tables usually given are of numbers from 1 to 10. The natural log of 245, or  $2.45 \times 10^2$ , is

$$.8961 + 2(2.3026), \text{ or}$$

$$.8961 + 4.6052 = 5.5013.$$

The fundamental principles of logs apply equally as well to this as to the common system. Multiplication and division can be performed, and powers and roots computed.

It is apparent from the foregoing that all that has been said about common logarithms does not apply to the Napierian logarithms, since in the latter system the mantissa is not independent of the location of the decimal point, and the same sequence of significant figures does not have the same mantissa.

**358. Change of Logarithmic Bases.**—Let  $y$  be the log to the base  $a$  of a certain number  $N$  and let  $x$  be the log to the base  $c$  of the same number. Then

$$\begin{aligned}\log_a N &= y \text{ and } N = a^y. \\ \log_c N &= x \text{ and } N = c^x.\end{aligned}$$

Hence,

$$a^y = c^x.$$

Taking the log of both sides to the base  $a$ ,

$$y = x(\log_a c), \text{ or } \log_a N = \log_c N \cdot \log_a c.$$

Taking the log of both sides (Art. 343) to the base  $c$ ,

$$x = y(\log_c a), \text{ or } \log_c N = \log_a N \cdot \log_c a.$$

From which we obtain

$$\log_a N = \log_a c \cdot \log_c N = \frac{\log_c N}{\log_c a}.$$

Note that changing from one base to another simply multiplies the logarithm of the number to the old base by the log of the old base taken to the new base. Changing from one base to another, then, simply involves the multiplication of the log by a constant.

Thus, the common log is given by

$$\text{Common log} = \text{Napierian log} \times \log_{10} e = \frac{\text{Napierian log}}{\log_e 10}$$

and the natural log is given by

$$\text{Napierian log} = \text{Common log} \times \log_e 10 = \frac{\text{Common log}}{\log_{10} e}$$

Since  $\log_{10} e = .4343$  and  $\log_e 10 = 2.3026$ , we have

$$\text{Common log} = \text{Napierian log} \times .4343 = \frac{\text{Napierian log}}{2.3026}$$

$$\text{Napierian log} = \text{Common log} \times 2.3026 = \frac{\text{Common log}}{.4343}$$



## CHAPTER XVI

### EXPONENTIAL FUNCTIONS AND THEIR RELATION TO LOGARITHMIC FUNCTIONS

#### 359. Comparison of curves,

$$y = r^x \text{ and } y = e^x.$$

Take  $y = r^x$  and resolve it into  $y = e^{mx}$ . This may be done because the base of a log may be changed from one number to another by multiplying the log by a constant. Since the log is really an exponent, this amounts to multiplying the exponent of the new base by a constant, as  $m$ , or

$$r = e^m.$$

Now the curve

$$y = e^{mx}$$

is made from the curve of

$$y = e^x$$

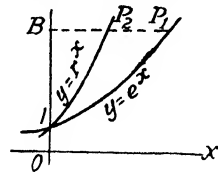

FIG. 119.

by substituting  $mx$  for  $x$  or by multiplying all of the abscissae of  $y = e^x$  by  $\frac{1}{m}$ .

For  $y = OB$ , the abscissae,  $BP_1$  and  $BP_2$ , are  $\log_r y$  and  $\log_e y$ , respectively.

Then

$$BP_2 = \frac{1}{m} BP_1.$$

That is,

$$\log_r y = \frac{1}{m} \log_e y.$$

When  $m$  is determined, we have a means of changing from a log system with base  $e$  to one with base  $r$ . The number  $\frac{1}{m}$  is called the modulus of the log system whose base is  $r$ .

Note that  $\frac{1}{m}$  is the  $\log_r e$ , or  $\frac{1}{\log_e r}$  according to Art. 358 preceding.

**360.** If we have given the curve  $y = r^x$  and desire to draw the graph of  $y = r^{x+h}$ , we simply translate the given curve  $y = r^x$  a distance of  $h$  units to the left.

What amounts to the same thing is to shift the coordinate axes  $h$  units to the right or in the positive direction, and use the new origin  $O'$ , which changes the equation of the curve to  $y = r^{x+h}$ .

Since  $y = r^{x+h} = r^x r^h$ , the ordinates of  $y = r^{x+h}$  will be  $r^h$  times the ordinates of  $y = r^x$ . The figures showing the transformation of the curve by both methods are Figs. 120 and 121.

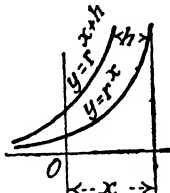

FIG. 120.

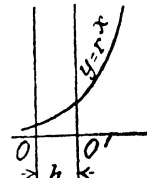

FIG. 121.

**361. Logarithmic and Exponential Relations.**—Consider the equations,

$$y = r^x, \text{ which is the exponential form, and}$$

$$x = \log_r y, \text{ which is the logarithmic form.}$$

These two forms are equivalent but one is in the inverse form from the other. If plotted, they represent exactly the same curve. This is analogous to the case where  $y^2 = x$  and  $y =$

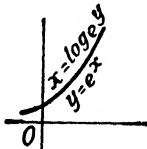

FIG. 122.

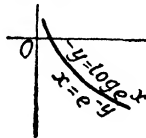

FIG. 123.

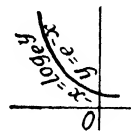

FIG. 124.

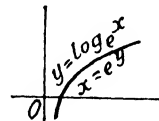

FIG. 125.

$\pm\sqrt{x}$  represent exactly the same curve. The curve is shown in Fig. 122.

The curve  $y = e^{-x}$  Fig. 124 is the curve  $y = e^x$ , reflected with respect to the  $Y$ -axis. The effect of interchanging  $x$  and  $y$  and of substituting  $-x$  for  $x$  and  $-y$  for  $y$  in the equation can be seen from the Figures 123, 124 and 125 and from comparison between them and Fig. 122.

**362. The Subtangent of the Exponential Curve.**—A curious property of the exponential curve is that the subtangent  $K$  of the curve is constant. If the tangent is drawn to the curve at the point  $P$  and intercepts the  $X$ -axis at  $T$ , the distance  $K$  or  $TD$  between this intercept and  $D$ , the foot of the perpendicular from  $P$ , is constant (see Fig. 126).

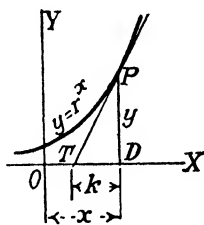

FIG. 126.

This distance is known as the subtangent for any curve.

$$K > 1 \text{ if } r = 2.$$

$$K < 1 \text{ if } r = 3.$$

$$\text{If } K = 1, r = e = 2.71828.$$

**363. Slope of Exponential Curves.**—The slope of  $y = r^x$  is from the figure  $\frac{y}{K}$ .

But  $K$  is a constant for all positions of  $P$ , or

$$\text{slope of curve at } P = cy, \tag{1}$$

where  $c = \frac{1}{K}$ .

From (1), we conclude that the slope of any exponential curve at a given point is proportional to the ordinate at that point.

At the point  $(0, 1)$ , the slope is  $c = \frac{1}{K}$ .

The value of  $K$  depends on the value of  $r$ , as shown in Art. 362.

When  $r = e$ ,  $K = 1$ ,  $c = 1$ , and (1) becomes

$$\text{slope of curve at } P = y.$$

This important relation is the reason for adopting the natural system of logs in higher mathematics, as the derivative is the function itself.

**364. Exponential Equations.  $r^x = b$ .**

It is sometimes necessary to find the value of  $x$  in such equations as

$$20^x = 75.$$

Such equations are solved by means of logarithms.

Let  $r^x = b$ .

Then  $\log r^x = \log b$ , since the logs of equals are equal,  
 or  $x \cdot \log r = \log b$ ,  
 whence

$$x = \frac{\log b}{\log r}.$$

We may solve a particular example, as  $20^x = 75$  by substitution, thus,

$$r = 20 \text{ and } b = 75.$$

$$x = \frac{\log 75}{\log 20} = \frac{1.875061}{1.301030} = 1.441211.$$

From the fundamental principle upon which logarithms are formed, the ordinates form a geometrical progression when the abscissae of the exponential curve form an arithmetical progression (Art. 341).

### 365. Compound Interest Law.

Let  $P$  = the amount invested.

$r$  = the rate of interest.

Then the interest at the end of the first year is  $Pr$ , and the accumulation at the end of the first year is  $P + Pr$ , or  $P(1 + r)$ .

The interest at the end of the second year is  $P(1 + r) \cdot r$ , and the accumulation is  $(P + rP) + (1 + r) \cdot Pr$ , or  $P(1 + r) + Pr(1 + r)$ , or  $(P + Pr)(1 + r)$ , or  $P(1 + r)(1 + r) = P(1 + r)^2$ .

The accumulation  $A$  or total sum after  $n$  years is

$$A = P(1 + r)^n.$$

If the rate of interest is 5 per cent compound interest, then

$$\text{Amount} = A = P(1 + r)^n = P(1.05)^n.$$

If years are plotted as abscissa and the amounts as ordinates, the curve will be an exponential curve.

$$\log_{10} 1.05 = .021.$$

$$\log_e 1.05 = 2.302 \times .021 = .048.$$

Hence,

$$e^{.048} = 1.05.$$

The equation then becomes

$$A = Pe^{.048n}.$$

This is of the form,

$$y = ae^{bx}.$$

**366. Logarithmic Increment.**—The compound interest law is one of the important laws of nature. As previously noted, the slope or rate of increase of the exponential function,

$$y = ae^{bx},$$

at any point is always proportional to the ordinate or to the value of the function at that point. Thus, in nature, when we find any function or magnitude that increases at a rate proportional to itself, we have a case of the exponential or compound interest law.

The law is often expressed by saying that the first of two magnitudes varies in geometrical progression while the second magnitude varies in arithmetical progression. A familiar example of this is the increase in friction as a rope is coiled about a post. The number of turns increases in arithmetical progression, while the friction increases in a geometrical progression (Slichter).

$y = ae^{bx}$  is the general form of exponential equations.

**367. Computations with Logarithms.**—Numerical computations by means of logarithms are not correct to more significant figures than the number of decimal places taken in the logarithm. *Conversely*, if a number in a computation is accurate to four significant figures, a four-place table will suffice for the computation.

If one of the numbers in a computation is accurate to only three figures, a slide rule, which is really a three-place mechanical log table, is sufficiently accurate to use.

If all the numbers are accurate to six significant figures, then a six-place log table should be used, if the accuracy is to be maintained.

**368. Modulus of Decay. Logarithmic Decrement.**—In a very large number of cases in nature, the exponential function occurs as a decreasing function rather than as an increasing one, so that the equation which represents the relation is of the form,

$$y = ae^{-bx},$$

where  $(-b)$  is essentially negative.

$(-b)$  is the modulus of decay or the log decrement, corresponding to an increase of  $x$  by unity.

A log decrement is shown by the series of natural and common logs, as they progress to the left of unity in Art. 342.

**369. Logarithmic Approximations.**

If  $x$  is very small, then

$$\log_e (1 \pm x) = \pm x - \frac{1}{2}x^2.$$

EXAMPLE.

$$\log_e (1.0025) = .0025 - \frac{.00000625}{2}$$

See Art. 464 of infinite series where the series that represents the logarithm is given.

**370. Some Additional Log Formulae.**

$$\log (abc) = \log a + \log b + \log c.$$

$$\log \left( \frac{ab}{cd} \right) = \log a + \log b - \log c - \log d.$$

$$\log (a^m b^n c^p) = m \cdot \log a + n \cdot \log b + p \cdot \log c.$$

$$\log \left( \frac{ab^m}{c^n} \right) = \log a + m \cdot \log b - n \cdot \log c.$$

$$\log (a^2 - b^2) = \log [(a + b)(a - b)] = \log (a + b) + \log (a - b).$$

$$\log \sqrt{a^2 - b^2} = \frac{1}{2} \log (a + b) + \frac{1}{2} \log (a - b).$$

$$\log (a^3 \cdot \sqrt[4]{a^3}) = \log a^3 + \log \sqrt[4]{a^3} = 3 \cdot \log a + \frac{3}{4} \log a.$$

$$= \frac{15}{4} \log a.$$

$$\log \sqrt[n]{(a^2 - b^2)^m} = \frac{m}{n} \cdot \log [(a - b)(a^2 + ab + b^2)] =$$

$$\frac{m}{n} \cdot \log (a - b) + \frac{m}{n} \cdot \log (a^2 + ab + b^2).$$

$$\log \sqrt{\frac{(a^2 - b^2)}{[a + b]^2}} = \frac{1}{2} \log (a + b) + \frac{1}{2} \log (a - b) - 2 \log (a + b)$$

$$= \frac{1}{2} \log (a - b) - \frac{3}{2} \log (a + b).$$

**371. Logarithmic Paper.**—Paper with the coordinate axes ruled in both directions to a logarithmic scale is called logarithmic paper. It is exceedingly useful in the plotting of power functions.

To plot  $y = ax^n$  [65] (Art. 258) on logarithmic paper, we take the log of both sides,

$$\log y = \log a + n \cdot \log x \quad (1)$$

If we put  $Y = \log y$ ,

$K = \log a$ ,

$X = \log x$ ,

equation (1) becomes

$$[86] \quad Y = nX + K.$$

Now the equation [86] represents a straight line if  $X$  and  $Y$  be taken as the variables. This is exactly the form of the curve, if we plot the values of  $x$  and  $y$  from equation [65] on logarithmic

paper, for, when we plot a value of  $x$  on logarithmic paper, the distance from the origin to the point on the  $X$ -axis whose abscissa is the same as the abscissa of  $x$  is nothing but the  $\log x$ , i.e.,  $X$ , and  $Y$  is similarly found.

Moreover, the slope of the straight line which represents equation [86] is  $n$ , the exponent of  $x$  in equation [65]. Also the intercept on the  $Y$ -axis is  $K$ , which is equal to  $\log a$ .

Hence, if values of  $x$  and  $y$  are plotted from [65] on log paper, the value of  $n$  in [65] appears as the slope of the straight-line graph, and the value of  $a$  can be read off directly on the vertical scale.

372. Examples of the power function graph are shown in Figs. 127 and 128. In Fig. 129 is shown the relation of space

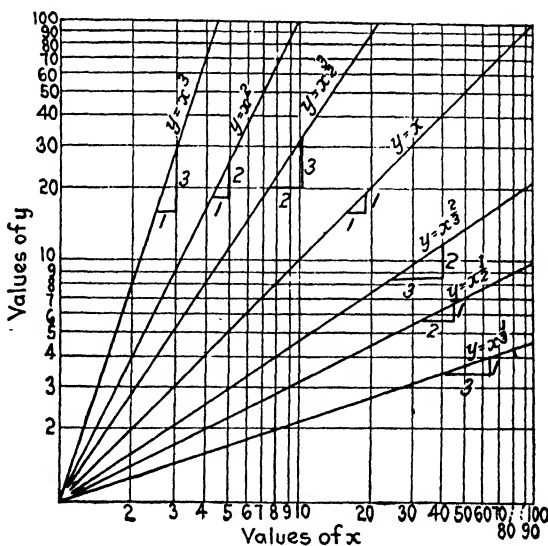

FIG. 127.

to time of falling bodies. In the plotting of power functions the point (1, 1) is first located, and through this point, a line is drawn having the slope  $n$ . The values of  $x$  and  $y$  are read directly from the graph.

Log charts are often made in small squares with the units from 1 to 10 in each square. Each square is a repetition of the preceding square, as shown in Figs. 127, 128, and 129.

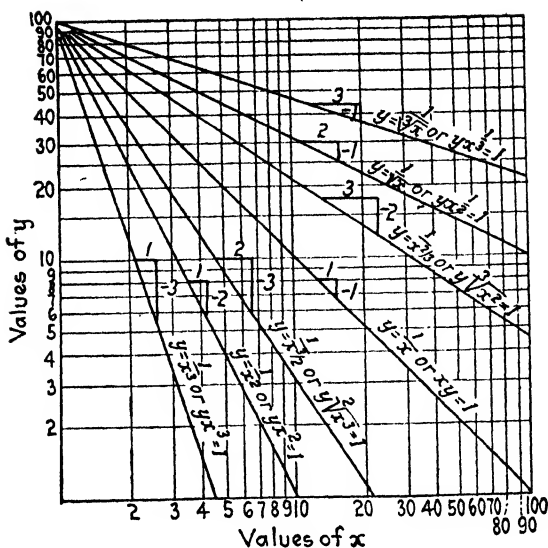

FIG. 128.

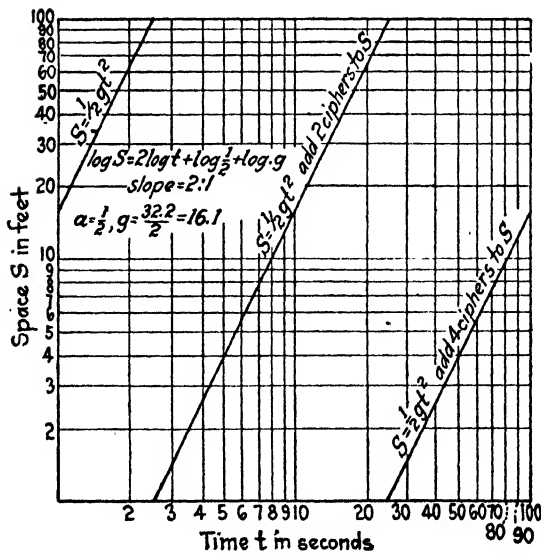

FIG. 129.



Each succeeding square, then, represents an increase of 1 in the log of the variable and its function, which is equivalent to moving the decimal point one place to the right. In the case of  $y = x^{\frac{2}{3}}$  (Fig. 130), it will be seen that if we move the decimal point two places in  $x$ , we move it three places in  $y$ , since the slope of the graph is  $\frac{2}{3}$ . The starting point of the graph is at the point (1).

It is convenient, in order to save space, to group the squares all in one square and thus cover the required range of the function in one square as was done in Fig. 129.

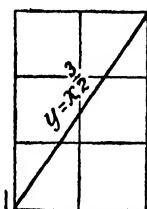

FIG. 130.

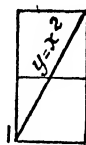

FIG. 131.

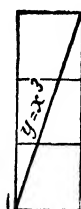

FIG. 132.

In all cases it is desirable to determine the location of the decimal point by inspection.

After reducing the function to the log form,

$$\log y = \log a + n \cdot \log x,$$

if  $a$  is present, we proceed in the same manner as in linear functions (Arts. 128 and 145).

$\log a$  is the  $Y$ -intercept.

$n$  is the slope of the graph.

In the case of  $y = 3(x + 3)^2$ , the  $Y$ -intercept is 3, and instead of finding the log of 3 and laying it out on the  $Y$ -scale, we simply locate the  $Y$ -intercept on the  $Y$ -axis at 3, since the scales are prepared so that this point represents the log of 3.

When  $(x + 3)$  is substituted for  $x$ , we have a different case from that where rectangular coordinates were used. We simply subtract 3 units, in this case, from the numbers on the  $X$ -scale and use this secondary scale for representing values of  $x$ . This secondary scale is shown in Fig. 133.

If a constant appears, modifying  $y$  values, as in

$$y = 3(x + 3)^2 - 3$$

or

$$y + 3 = 3(x + 3)^2,$$

make a supplementary scale on the  $Y$ -axis in the same manner.

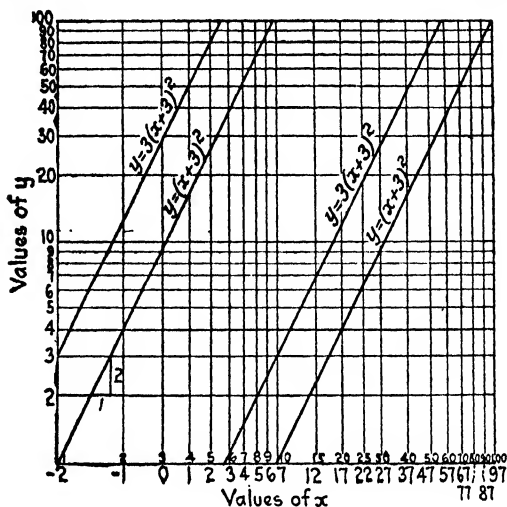

FIG. 133.

**373.** A log scale is easily understood when we consider that we compute the values of the logs of the numbers from 1 to 10 and lay off these values to some scale, as in the figure below.

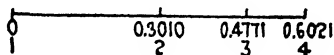

FIG. 134.

In place of the value of the log in the scale, we place the number whose log is represented there, and in this way we eliminate the necessity for substituting the values of the numbers for the logs and conversely. Thus, instead of placing 0 at the origin, we place 1 there, since 0 is the log of 1, and instead of placing the decimal .3010 at the point which represents the log of 2, we place the number 2, itself, there.

**374.** The log paper is a means of establishing a formula to relate the data secured from experiments, if the relation of the

variables is supposed to be expressed in the form of a power function.

Plot the data and if the points lie in a straight line, the line represents a power function and the equation connecting the variables can readily be found by locating the *Y*-intercept and determining the slope of the line which are the coefficient and the exponent, respectively, of *x* in the power function,

$$y = ax^n. \quad [65]$$

**375. Logarithms in Geometrical Progressions.**—The line connecting the ends of the ordinates of the arithmetical progression is a straight line. Likewise, if we plot the logarithms of the terms of a geometrical progression, the line joining the ends of the ordinates is a straight line.

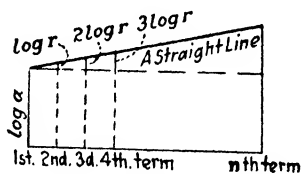

FIG. 135.

For from

$$a, ar, ar^2, ar^3, \dots ar^{n-1} \quad [76]$$

taking the logs,

$$\begin{aligned} \log a, \log a + \log r, \log a + 2 \cdot \log r, \log a + 3 \cdot \log r, \\ \log a + 4 \cdot \log r, \dots \log a + (n - 1) \log r. \end{aligned}$$

Plotting the graph with the numbers of the terms as abscissae and the logs of the terms as ordinates gives a graph of the form shown in Fig. 135. Since the length of each ordinate is the length of the previous ordinate plus the length which represents *log r*, the graph will be a straight line.

**376.** By means of a log scale, such as a slide rule, any term can be scaled immediately, or by use of a standard decimal scale, the ordinate can be measured as a logarithm and the term found from a log table. Any number of geometric means can be found in this manner.

**EXAMPLE.**—Find four geometric means between 2 and 90.

Since there will be six terms, we will start by laying off six points on a horizontal scale at equal distances from each other.

$$\log 2 = .301.$$

$$\log 90 = 1.954.$$

At the first of the six points, erect an ordinate representing the  $\log 2 = .301$  and at the sixth point erect an ordinate representing the  $\log$

90 = 1.954. Connect the ends of these ordinates with a straight line. The ordinates at the other four points which are cut off by this straight line represent the four geometric means, and by scaling these ordinates their values are seen to be .631, .962, 1.292, 1.623. From the log tables, find the antilogs of these logs and the results will give the series, 2, 4.28, 9.16, 19.6, 41.95, 90.

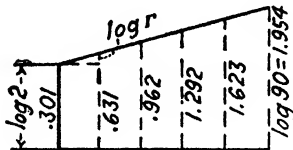

FIG. 136.

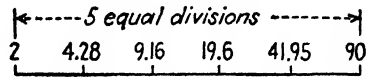

FIG. 136a.

377. The ratio  $r$  can also be easily found, for the log of  $r$  is the increase in the ordinates for each term. Consider the first and second terms,

$$.631 - .301 = .33.$$

Therefore,  $r$  is the number whose log is .33 which is 2.14 and this is the geometric ratio.

378. Still another method for getting geometrical means between two numbers is by means of a log scale such as is found on a slide rule. If four intermediate means are desired between two terms, divide the distance between the numbers on the scale into 4 + 1 equal spaces and read the numbers at the division points direct from the scale. The method is illustrated in Fig. 137 below and 136a for previous example.

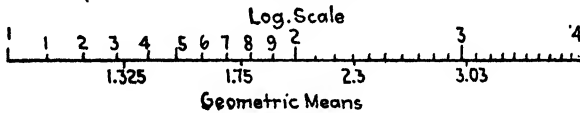

FIG. 137.

379. **The Power Function Compared with the Exponential Function.**—The three fundamental laws of natural science are:

The parabolic law, expressed by the power function,

$$y = ax^n, \quad [65]$$

where  $n$  may be either positive or negative.

The harmonic or periodic law,

$$y = a \sin nx,$$

which is fundamental to all periodically recurring phenomena.

The compound interest law, which was discussed in Arts. 365 and 366.

In the power function [65],  $y = ax^n$ , as  $x$  changes by a constant factor (as  $m$ ),  $y$  changes by a constant factor.

Putting the expression of the relation differently, if  $x$  increases according to a geometrical progression,  $y$  increases according to a geometrical progression also.

EXAMPLE.—Let  $m$  be nearly 1 or  $1 + r$ , where  $r$  is the per cent change in  $x$ .

Then the ratio of change is

$$\frac{y'}{y} = \frac{f(x + rx)}{f(x)} = \frac{a[(x + rx)^n]}{ax^n} = (1 + r)^n.$$

$$(1 + r)^n = 1 + nr, \text{ approx.}$$

$$\frac{y' - y}{y} = \frac{ax^n(1 + r)^n - ax^n}{ax^n} = nr.$$

This indicates that the per cent of change in  $y$  is  $nr$ , while the per cent of change in  $x$  is simply  $r$ . Therefore, the per cent of change in the function is  $n$  times the per cent of change in the variable. Therefore, to determine whether experimental data follow the power function law, see if the constant per cent change in the variable produces a per cent change in the function equal to  $n$  times this constant factor.

**380. Changes in the Exponential Function.**—Let  $y = ae^{bx}$ . Since, in the power function, the function was increased by a constant multiple, a similar increase will be assumed in the exponential function. But from the previous article (379), increasing  $x$  by a constant, as  $x + h$ , increased  $y$ , or the function by a constant factor, or

$$\frac{y'}{y} = \frac{F(x + h)}{F(x)} = \frac{ae^{b(x+h)}}{ae^{bx}} = e^{bh}.$$

The factor  $e^{bh}$  is independent of  $x$  or is a constant for a constant  $h$  and is the factor by which  $y$  is increased when  $x$  is increased to  $(x + h)$ .

In other words, instead of the variable and the function both varying according to geometrical progressions, as in the power functions, the variable  $x$  in the exponential function varies according to an arithmetical progression, when the function  $y$ , or  $ae^{bx}$ , varies according to a geometrical progression.

**381. To Determine Exponential Relation.**—If it is found that a change in  $x$  by a constant increment, as  $x + 2$ , causes a change in the function by a constant factor, as  $16y$ , then the relation between the variable and the function can be expressed by an equation of the exponential type.

By plotting the values of  $x$  and  $y$  on semilog paper, the graph is a straight line, and the constants of  $y = ae^{bx} + c$  are determined.

**Comparison of Exponential Formulae.**—Consider the different types of exponential formulae, as

$$[87] \quad y = e^x,$$

$$[88] \quad y = ae^x, \text{ and}$$

$$[89] \quad y = ae^{kx}.$$

Consider first the curve represented by [87]. This curve is shown in Fig. 138.

The curve approaches the  $X$ -axis as it extends to the left but it never intersects the axis.

As the point  $P$  is taken higher on the curve, that is, as the abscissa of  $P$  increases, the slope of the curve at this point increases.

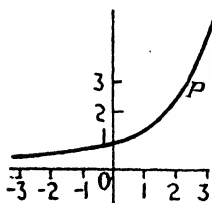

FIG. 138.

The graph of [88] is similar in form to the graph of [87] except that every ordinate of the latter curve is multiplied by  $a$ . The ordinate scale can also be changed so that a given distance represents an ordinate  $a$  times as long, and the curve of [87] used to represent the graph of [88].

In [89] the values of  $y$  for different values of  $x$ , as  $1, 2, 3, 4, \dots$  are the same as in [88] at  $x = k, 2k, 3k$  etc., and if  $k$  is positive, the graph is the same as the graph of [88] with its horizontal scale changed. By taking a standard  $y = e^x$  curve and changing both the vertical and the horizontal scales, we can change it to represent [89].

If  $k$  is negative, the graph is reversed as regards positive and negative values of  $x$  (see Art. 361).

## CHAPTER XVII

### THE SLIDE RULE

**382.** Although engineers use the slide rule more, perhaps, than any other class of men, we believe that the majority of engineers confine its use to the simplest kind of operations. If the construction of the different scales is understood, their use becomes less mysterious, and consequently they are used with confidence in more involved problems.

We assume that the reader has a fair knowledge of the rule and understands the subject of logarithms as given in Arts. 341 to 359.

The slide rule is really a mechanical equivalent of a log table, with the advantage that the anti-logs replace the mantissas on the log scales and are read directly. Since logarithms are added or subtracted for the simple operations of multiplication or division, the rule is a mechanical means for adding or subtracting the scales for these same operations. The supplementary scales such as the power or trigonometric scales are also arranged for their addition or subtraction to the fundamental scales.

Recent developments of the slide rule have materially increased its usefulness, and, although we do not wish to commercialize a certain make of rules, we find it necessary to mention the copyrighted trade names in order to explain certain operations on these rules. They are the Polyphase Duplex Trig,\* Polyphase Duplex Decitrig,\* Log Log Duplex Trig\* and the Log Log Duplex Decitrig.\*

The Polyphase Duplex Trig and the Polyphase Duplex Decitrig, which will be used in our description of operation, differ only in that the former trigonometric scales are in degrees and minutes, and the latter is in degrees and decimals. These rules have additional folded scales that will be described later. Their numerical equivalents of the angles are read on the longer *C*-, *D*-, *CI*- and *DI*-scales instead of the shorter *A*- and *B*-scales previously made. These scales are also double numbered, which

\* Trade-mark registered U.S. Patent Office by Keuffel and Esser Co.

makes available all six of the trigonometric functions as factors in any operation of the rule.

The Log Log Duplex Trig and Log Log Duplex Decitrig have the same scales as the rules previously mentioned with the additional Log Log scales. These rules are especially useful where powers and roots form a considerable amount of the computations.

**383. The Log L-scale.**—Contrary to all teachings familiar to us, we will take up first the log scale marked *L* on the 10-inch rule. This is called the scale of equal parts. Logarithms form an arithmetical progression and can, therefore, form a scale of equal parts.

The mantissas from 1 to 10 are spaced equally for the interval of 10 inches. They, of course, are all decimal numbers as shown below.

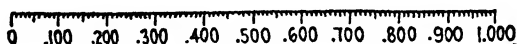

FIG. 139.

Ten intermediate divisions are made between each number and these divisions are again divided, thus making it equivalent to a three-place logarithmic table. By means of a divider, we can measure two distances, as 2 inches which corresponds to the mantissa .2 and 3 inches which corresponds to the mantissa .3, and add them. The result, since the dividing numbers are equally spaced, is 5 inches, which corresponds to the mantissa .5. Now refer either to the D-scale or to a table of logarithms and find the numbers whose antilog are .2, .3, and .5, thus,

$$\begin{aligned} \log 1.58 + \log 2.01 &= \log 3.18, \text{ or} \\ 1.58 \times 2.01 &= 3.18. \end{aligned}$$

This is the fundamental scale of the rule and the unit of the scale is 10 inches. Each of the divisions .100, .200, .300, etc., is 1 inch apart, or  $.100 \times 10 = 1.00$ ,  $.200 \times 10 = 2.00$ ,  $.300 \times 10 = 3.00$ , etc.

**384. The C- and D-scales.**—The graduations of the *C*- and *D*-scales are taken from the logarithmic *L*-scale except that the numbers which correspond to the logarithms are marked on the rule instead of the numbers which equal the logarithms. The numbers found on the rule and the corresponding logs are as follows:



Numbers	1	2	3	4	5	6	7	8	9	10
Logs	0	.301	.477	.602	.699	.778	.845	.903	.954	1

Compare them to each other on the *L*- and *D*-scales.

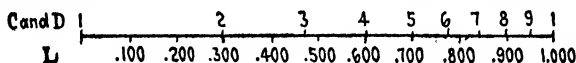

FIG. 140.

The advantage of putting the number instead of its log on the scale is that it is then unnecessary to look up the number in a table, as it is read direct. We can take the divider and add the distance given for 2 and the distance given for 3 (on the *D*-scale), and the added distances measured to 6.

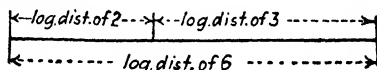

FIG. 141.

The slide of the rule permits us to add or to subtract these

distances which multiply or divide the numbers corresponding to the logarithms.

**385. The Regular Setting for Multiplication.**—The addition of two logarithmic scales, as the log scale which corresponds to 2 plus the log scale which corresponds to 3, is equal to the log scale which corresponds to 6, or to the product of the two numbers 2 and 3, which is 6.

While multiplications can also be made by the inverted scales, which will be explained later, the above setting can also be used to multiply reciprocals of numbers, which, of course, gives a quotient. In order to distinguish this setting, we will call it the *regular setting for multiplication* and describe it as follows:

If either index (figure 1 on the rule) is set to measurements on any fixed scale, the runner moved to any number on the slide, and the result read on the fixed scale used, we will term this operation the *regular setting for multiplication*.

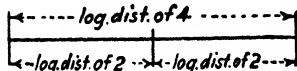

FIG. 142.

**386. The Regular Setting for Division.**—The subtraction of one logarithmic scale from another, as the logarithmic scale which corresponds to 2 from the logarithmic scale which corresponds to 4, is equal to the logarithmic scale which corresponds to 2, or the quotient of 4 divided by 2, or 2.

Divisions can also be made with the inverted scales which will be explained later (Art. 394) but in order to distinguish this set-

ting, we will call it the *regular setting for division* and describe it as follows:

If any number on a slide scale is set to a number on the fixed scale and the answer read on the fixed scale opposite the index of the slide, we will term this operation the *regular setting for division*.

If an expression contains three numbers, use the regular setting for division for the first setting in all cases.

EXAMPLE.—Solve  $\frac{a \times b}{c} = x$ .

Proceed as in the regular setting (Art. 386) by subtracting the log scale of  $c$  from the log scale of  $a$ ; then add the log scale of  $b$  to that result on the  $C$ -scale.

$$\begin{array}{ccc} D & C & D \\ \frac{a}{c} \times b & = & x \\ C & & \end{array}$$

Set runner to  $a$  on  $D$ .

Set  $c$  on  $C$  or on  $CF$  to runner.

Set runner to  $b$  on  $C$  or on  $CF$ .

Read answer at runner on  $D$  or on  $DF$ .

**387.** If it is found necessary to shift the slide and one index is replaced by the other, the quantity is either multiplied or divided by 10, which does not affect the order of the significant figures and is taken care of by the location of the decimal point.

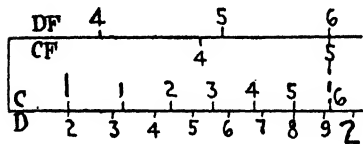

FIG. 143.

**388.** The decimal point should be located by inspection or by

method given in Art. 30.

**389. The Folded Scales.**—The  $CF$ -,  $CIF$ - and  $DF$ -scales are based on the same unit length as the  $C$ -,  $CI$ - and  $D$ -scales, but the scales are shifted  $\log$  of  $\pi$ , which makes the index 1 near the center of the rule.

If half of the slide is in the rule, the complete  $CD$ -scale can be found, either on the folded  $CF$ - and  $DF$ -, or on the  $C$ - and  $D$ -scales, which makes it unnecessary to shift the slide. If the measure is taken on the folded slide scale  $CF$ , the transfer must be measured on the folded fixed scale  $DF$ , unless  $\pi$  enters into the calculation.

If, in the setting shown, a measurement, as  $\log 5$ , is to be added, it cannot be found on the  $C$ -scale but is given on the  $CF$ - or folded scale without shifting the slide.

**390.** Since the  $DF$ -scale is shifted  $\log$  of  $\pi$  distance to the left of the  $D$ -scale, then the  $DF$ -scale reading will in all cases be greater than the readings on the  $D$ -scale, by an amount equal to the distance shifted, or  $\log$  of  $\pi$  distance.

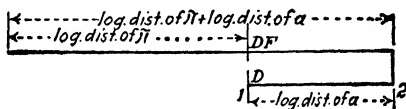

FIG. 144.

The same relation exists between the  $CF$ - and the  $C$ -scales.

Setting which gives the answer on the  $D$ -scale can be multiplied by  $\pi$ , when the answer is read on the  $DF$ -scale instead of on the  $D$ -scale.

*Conversely*, setting which gives the answer on the  $DF$ -scale can be divided by  $\pi$ , when the answer is read on the  $D$ -scale instead of on the  $DF$ -scale.

The  $C$ - and  $CF$ -scale furnish the corresponding circumferences for diameters of circles. A diameter on  $C$  has its circumference directly on  $CF$ .

**391.** In order to multiply an expression by  $\pi$ , use the  $C$ - and  $D$ -scales, but instead of reading the answer on the  $D$ -scale, read it on the  $DF$ -scale, which will automatically multiply the expression by  $\pi$ .

Let  $x = ab\pi = \pi \times 5 \times 6$ .

Set index of slide to 5 on  $D$ .

Set runner to 6 on  $C$ .

Read answer 94.3 on  $DF$ .

Remember that a shift from the lesser scale to the greater scale (the folded scale has a value of  $\pi$  where the  $C$ - and  $D$ -scales begin) must mean that the answer is being multiplied by  $\pi$ .

**392.** In order to divide an expression by  $\pi$ , use the  $DF$ -,  $CF$ -, and  $CIF$ -scales, but instead of reading the answer on the  $DF$ -scale, read it on the  $D$ -scale, and the expression is then divided by  $\pi$ .

Let  $x = \frac{ab}{\pi} = \frac{12 \times 21}{\pi}$ .

Set index of slide to 12 on *DF*.

Set runner to 21 on *CF*.

Read answer 80.2 under runner on *D*.

**393. The Inverted Scales.**—The *CI*, *DI*, and the *CIF* are the inverted scales. Instead of increasing when measured from left to right, the direction of the measurements is from right to left. The scales are taken from the *L*-scale in the same manner as the *C*- and *D*-scales were taken, but from the opposite direction.

The measurements are inverted when measured with the *C*- and *D*-scales, and the reason is easily seen from the figure which follows. The reciprocal scales are in red.

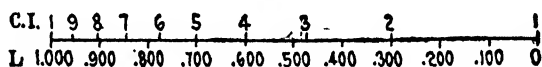

FIG. 145.

The log measurements are added when the numbers are set together on the *CI*- and *D*-scale, and the product is found on *D* opposite the index on *CI*.

**394.** For division, the index on the *CI*-scale is set to the dividend on the *D*-scale, and opposite the divisor on *CI* the quotient is found on *D*. A similar relation exists between *D* and *DI*.

Divide 4 by 2 = 2.

$\log 4 - \log 2 = \log 2$ .

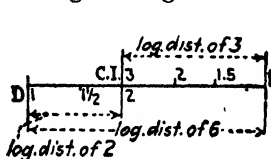

FIG. 146.

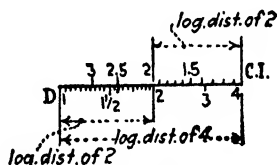

FIG. 147.

We will call these the inverse settings for multiplication and division.

These settings are given although their use is not advocated, since they oppose the regular settings and confuse and conflict with simple rules. We prefer to reduce *all* operations to the *regular settings* (Arts. 385 and 386).

**395. The *CIF* or Inverted and Folded Scale.**—This *CIF*-scale is the same as the *CI*-scale except that it is folded or shifted to the right log of  $\pi$  distance from the *CI*-scale in the same manner as the *CF*- and *DF*-scales are folded with regard to the *C*- and *D*-scales.

The *CIF*-scale should be used in connection with the other folded scales unless  $\pi$  is in the expression. If over half of the slide is in the rule, the full scale can be found on either the *CI*- or the *CIF*-scale and shifting is unnecessary.

**396. The Reciprocal Scales.**—Comparing the *C*- and the *CI*-scales, we see that one is the reciprocal of the other.

If, then, we make a setting of the rule by adding  $\log$  of  $b$  a measurement on the *C*-scale to  $\log$  of  $a$ , a measurement on the *D*-scale, by the *regular setting* (Art. 385), then

$$a \times b = x.$$

If the *CI*-scale, which is the reciprocal scale of the *C*-scale, is used, the operation gives

$$a \times \frac{1}{b} = x, \text{ or } \frac{a}{b} = x.$$

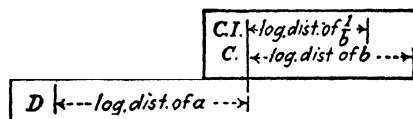

FIG. 148.

If, then, a number occurs in the denominator, we can multiply its reciprocal by the *regular setting* (Art. 385) by using the *CI*-scale. This rule, of course, also applies to the *D*- and *DI*-scales.

**EXAMPLE.**—Solve  $471 \times \frac{1}{322} = x$ .

Consider as a regular setting for multiplication (Art. 385) which would be

$$471 \times \frac{1}{322} = x.$$

Set runner to 471 on *D*.

Set index of slide to runner.

Set runner to 322 on *CI*.

Read answer 1.46 on *D*.

After considerable practice, the index may be set to the first number without using the runner.

**397. Form  $xy = C$ .**

In plotting a graph of  $xy = C$ , the ordinate  $y = \frac{C}{x}$ . By setting the index of the *CI*-scale to  $C$  on the *D*-scale, the readings of  $y$  for corresponding values of  $x$  can be found without changing the setting.

**398. Form  $\frac{a}{b} \times \text{Variable Quantity} = x$ .**—Since the quotient of  $\frac{a}{b}$  is opposite the index of the slide, an additional factor can be included in the operation without changing the setting.

The expression then becomes

$$\frac{a}{b} \times c = x.$$

Set runner to  $a$  on  $D$ .

Set  $b$  on  $C$  to runner.

Set runner to  $c$  on  $C$ .

Read answer under runner on  $D$ .

EXAMPLE.—Solve  $\frac{24 \times c}{33}$ , where  $c$  has the values 1, 2, 3, 4, 5, 6, 7, 8.

Set runner to 24 on  $D$ .

Set 33 on  $C$  to runner.

Set runner to 1, 2, 3, 4, 5, 6, 7, 8, on  $C$ , consecutively.

Read .727, 1.45, 2.18, 2.9, 3.64, 4.36, 5.09, 5.81 under runner on  $DF$  and  $D$ .

**399. Form  $\frac{a}{b} \times \frac{1}{\text{Variable Quantity}} = x$ .**—The regular setting (Arts. 385 and 386) can also be used with  $\frac{a}{b}$  if  $c$  is inverted. We then have

$$\frac{a}{b} \times \frac{1}{c} = x, \quad \text{or} \quad \frac{a}{bc} = x.$$

We proceed as in the previous case for  $\frac{a}{b}$ , regular setting (Art. 386).

Move the runner to  $c$  as before, but find it on the  $CI$ - or  $CIF$ -scale, since  $\frac{1}{c}$  is the reciprocal of  $c$ .

Set  $b$  on  $C$  to  $a$  on  $D$ .

Set runner to  $c$  on  $CI$  or  $CIF$ .

Under runner on  $D$  find answer.

EXAMPLE.—Solve  $\frac{25}{8 \times c}$  where  $c = 1, 2, 3, 4, 5, 6, 7, 8$ .

Set runner to 25 on  $D$ .

Set 8 on slide  $C$  to runner.

Set runner to 1, 2, 3, 4, 5, 6, 7, 8, consecutively, on  $CI$  or  $CIF$  and read 3.12, 1.56, 1.04, .78, .625, .521, .440, and .391 on  $D$  and  $DF$ .

**400. Form  $a \times b \times \text{Variable Quantity} = x$ .**—This form includes

$$a \times b \times c = x, \quad \text{or } a \times b \times \frac{1}{c} = x$$

where  $c$  has different values.

For all expressions containing more than two numbers, the numbers should be arranged to perform the regular setting for division (Art. 386) first.

The  $a \times b$  part of the expression can be thought of as being  $\frac{a}{\frac{1}{b}}$ ,

which is a division form provided  $b$  is read on the *CI* or *CIF*, the inverted scales. We proceed then as a regular setting for division (Art. 386) but measure  $b$  on the inverted scales.

The expression  $a \times b \times c = x$  then becomes

$$\frac{a}{\frac{1}{b}} \times c = x,$$

which reduces to the same case as Art. 398 if  $b$  is taken on an inverted scale.

**EXAMPLE.**—Solve  $41 \times 81 \times c = x$

where  $c = 1, 2, 3, 4, 5, 6$ .

Set runner to 41 on *D*.

Set 81 on slide *CI* to runner.

Set runner on *C* to 1, 2, 3, 4, 5, 6.

Read answers 3320, 6640, 9960, 13,300, 16,600, 19,900, on *D* and *DF*.

**EXAMPLE.**—Solve  $36 \times 51 \times 72 = x$ .

Set runner to 36 on *D*.

Set 51 on *CI* to runner.

Set runner to 72 on *CF*.

Read answer 132,200 under runner on *DF*.

For  $a \times b \times \frac{1}{c} = x$ , or  $\frac{ab}{c} = x$ , proceed as before, with the regular settings (Arts. 386 and 385), but use the inverted scale for  $c$ .

Arrange mentally in the form,

$$\frac{a}{\frac{1}{b}} \times \frac{1}{c} = x.$$

EXAMPLE.—Solve  $\frac{26 \times 14}{9} = x$ .

Set runner to 26 on *D*.

Set 14 on slide *CI* to runner.

Set runner to 9 on *CIF*.

The answer, 40, is found under runner on *DF*.

The operation for 9 was shifted to the folded inverted scale because it could not be found on the *CI*-scale; yet half of the slide was in the rule.

Compare this with Art. 398 and note the difference in method.

EXAMPLE.—Solve  $\frac{42 \times 63}{c} = x$ , where  $c = 1, 2, 3, 4, 5$ , etc.

Set runner to 42 on *D*.

Set 63 on *CI* to runner.

Set runner to 1, 2, 3, 4, 5, etc., on *CIF* and *CI*.

Read answers 2650, 1320, 882, 661, 529, etc., on *D* and *DF*.

Caution.—In setting to a number on an inverted scale, as 63, be sure that the reading is made on the proper side of the 6.

**401. Form  $a \times b \times c = x$  Folded Scale.**—Another method of finding the product of three factors is by using the folded scales *DF* and *CF* in connection with the *CIF*-scale, which is practically the same thing as the previous operation except that it is with the folded scale.

$$a \times b \times c = x.$$

Set runner to  $a$  on *DF*.

Set  $b$  on slide to runner (Art. 386).

At  $c$  on *CF* read  $x$  on *DF* (Art. 385).

If  $c$  cannot be found on *CF* without shifting the slide, read it on the *C*-scale and  $x$  on *D*.

This process is necessary when an expression is divided by  $\pi$  (Art. 392).

**402. Form  $\frac{1}{a \times b \times c} = x$ .**—This form can be taken as in Art. 400,  $a \times b \times c$ , which gives the reciprocal of the answer. To invert this answer, transfer from the *D*-scale where the answer is regularly found to the inverted *CI*-scale.

The indices of the *CI*- and *D*-scales must be made to coincide before the transfer is made.



Example.—Solve  $\frac{1}{2 \times 3 \times 6} = x$ .

Proceed as for  $2 \times 3 \times 6$  (Art. 400), using regular settings (Arts. 386 and 385).

Set runner to 2 on *D*.

Set 3 on *CI* to runner.

Set runner to 6 on *C*.

Set index of slide to index of *D*.

Read answer .0278 under runner on *CI* instead of on *D*.

**403. Expressions Multiplied by  $\pi$ .**—Let the expression be

$$x = \frac{\pi \times a \times b}{c} = \frac{\pi \times 42 \times 6}{11}.$$

Put in form mentally for *regular setting for division* (Art. 386),

$$x = \frac{a}{1} \times \frac{1}{c} \times \pi = \frac{42}{1} \times \frac{1}{11} \times \pi.$$

Since the expression has  $\pi$  as a multiplier, the operation is done on the *C*- and *D*-scales and when transferred to the folded scales is multiplied by  $\pi$  (Art. 391).

Set runner to 42 on *D*.

Set 6 on *CI* to runner (6 is inverted).

Set runner to 11 on *CI* (11 is inverted).

Read answer 72 under runner on folded scale *DF*.

Transferring answer from *C*- and *D*-scales to folded scale multiplies by  $\pi$ .

**404. Expressions Divided by  $\pi$ .**

Let

$$x = \frac{a \times b}{\pi c} = \frac{37 \times 5}{2\pi}.$$

Put in form mentally for *regular setting for division* (Art. 386),

$$\frac{a}{1} \times \frac{1}{c} \times \frac{1}{\pi}$$

Since the expression has  $\pi$  as a divisor, the operation is done on the folded scales and when transferred to the *D*-scale is divided by  $\pi$  (Art. 392). Another condition evident is that the *b* and *c* are both inverted and we, therefore, use the inverted

folded scales for these numbers and with the regular settings (Arts. 386 and 385).

Set runner to 37 on *DF*-scale.

Set 5 on *CIF* to runner.

Set runner to 2 on *CIF*.

Read answer 29.5 under runner on *D*.

**405. Proportion.**—A proportion may be put in the form of two equal ratios as

$$\frac{a}{b} = \frac{c}{d'} \quad \frac{90}{82} = \frac{25}{x}, \quad \frac{y}{48} = \frac{6}{32}$$

Since the ratios are in the form of a division, their quotients are equal. Therefore, the setting of the rule for one ratio remains set for *any other equal ratio*. If 2 on the *C*-scale is set to 4 on the *D*-scale, then 3 on the *C*-scale is opposite 6 on the *D*-scale, and 7 on the *CF* folded scale is opposite 14 on the *DF* folded scale, and so on.

It is important to note that all numerators are on the *C*- or *CF*-scales and all the denominators are on the *D*- or *DF*-scales. The numerators may also all be taken on the *D*-scale and all denominators on the *C*-scale, but all numerators must appear on one scale and the denominators on the other.

In the first numerical example above, the rule is set to 90 on *C* to 82 on *D*. Opposite 25 on the *C*-scale, read 22.8 on *D* for the *x* value. For the other numerical example, set 6 on *C* to 32 on *D*. Opposite 48 on *D*, read  $y = 9$ .

**406. Inverse Proportion.**—If 12 men can perform a piece of work in 8 days, how long will it take 16 men to do it? Evidently it will take a lesser number of days for a greater number of men to do the same amount of work; this relation of a *greater* requiring *less* is called an inverse proportion. The proportion in the form of two ratios for the foregoing problem is

$$\frac{12}{16} = \frac{x}{8}$$

To solve, we set 12 on *C* to 16 on *D* and at 8 on *D* read *x* equals 6 on *C*. Again, since the *CI*-scale is an inverted or reciprocal scale, the inverse proportion may be set up as a *direct* proportion, provided that the scale is used. Then 12 on the *CI*-scale is set to 8 on the *D*-scale and opposite 16 on the *CI*-scale and read 6 on the *D*-scale.

The inverse proportion can be considered as being measured in the same way as direct proportion except that the *CI*-scale or inverted scale should be used instead of the *C*-scale.

This gives the inverse proportion,

$$CI : D :: (CI)_1 : D_1,$$

or

$$\frac{CI}{D} = \frac{(CI)_1}{D_1}.$$

**407. The A- and B-scales.**—We will now construct another scale by multiplying all of the logs of the log *L*-scale by 2. This we know, squares the numbers which correspond to the logs.

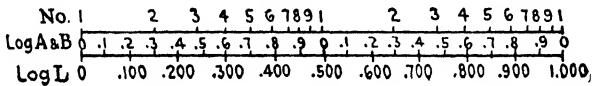

FIG. 149.

This results in two scales, each 5 inches long. In multiplying beyond .500, we really get 1.2, 1.4, etc., which gives us a characteristic as well as the mantissa, but since we are considering only the mantissa, we drop the characteristic on the slide rule. The numbers are substituted for the logs and this is the manner in which the *A*- and *B*-scales are made.

A distance measured on the *C*- or *D*-scale and taken on the *A*- and *B*-scale gives the square of the number.

*If, then, one of the factors is squared, it should be measured on the C- or D-scale, and this distance taken or read on the A- or B-scale, which automatically squares the number.*

All other numbers must be read on the *A*- and *B*-scales, else they will be squared also.

**408.** The numbers on the *C*- and *D*-scales will be the square roots of those on the *A*- and *B*-scales, because the scale is twice as long and the logs corresponding will be one-half as large.

*Any operation which has a square root as a factor should be measured on the A- and B-scales and referred to the C- and D-scales to extract the square root automatically.*

All other numbers must, therefore, be measured on the *C*- and *D*-scales. Numbers can be squared directly by placing the glass indicator to the number on the *D*-scale and reading the square of the number on the *A*-scale directly above.

Likewise, the square root of a number is found by placing the indicator to the number on the *A*-scale and reading the square

root of the number on the *D*-scale. Care must be taken to use the right scale, for the  $\sqrt{6}$  is not the same as the  $\sqrt{60}$ . Use the left scale for an odd and the right scale for an even number of digits. Apply the same reason for this that you do for marking a number into sets of two digits before extracting the square root.

EXAMPLE.—Find the square of 23.2.

Set the runner to 232 on *D*.

Under runner find answer 538 on *A*.

EXAMPLE.—Find  $\sqrt{3129}$ .

Set runner to 313 on right *A*-scale.

Under runner find answer 56 on *D*.

**409. The *K*-scale.**—If we multiply the logs by 3 on the log *L*-scale, construct the scale, and then replace the logs by their corresponding numbers, these numbers will be the cubes of the numbers having the same measurements on the *D*-scale.

The *K*-scale consists of three scales, one-third the unit length or each  $3\frac{1}{3}$  inches long.

If the runner is set to a number on the *D*-scale, the reading on the *K*-scale will give the cube of that number. In the same manner, if the runner is set to a number on the *K*-scale, the reading on the *D*-scale will be the cube root of that number. Care must be taken to select the proper scale. If a number is

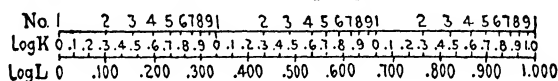

FIG. 150.

separated into groups of three digits beginning at the decimal point, as for extracting the cube root in arithmetic, thus,

$$3\sqrt[3]{428.21},$$

then for one digit on the left, use the left scale. For two digits, use the center scale and for three digits, use the right scale.

EXAMPLE.—Solve  $(34.1)^3 = x$ .

Set runner to 341 on *D*.

Under runner read answer 39,600 on *K*.

EXAMPLE.—Solve  $\sqrt[3]{433}$ .

Set runner to 433 on right *K*-scale.

Under runner read answer 7.56 on *D*.

**410. The Tangent Scale.**—The tangent scale is made from the log *L*-scale in the same manner as the *C*- and *D*-scales. The

angle is substituted for the log of the tangent. This amounts to saying that the tangent scale measures the log of tangent which corresponds to the angle.

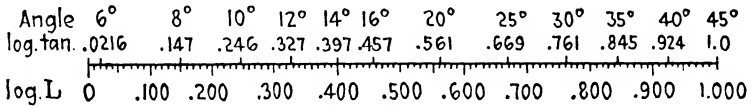

FIG. 151.

Accordingly, the tangent of the black angle on *T* is on scale *C* at the hairline or on *D* when the indexes of *T* and *D* coincide. The left index of *C* represents a tangent equal to 0.1 and the right index, which corresponds to 45° and equals 1.0 naturally. For tangents of angles greater than 45° the relation  $\cot \theta = \tan (90^\circ - \theta)$  can be used. It will be noticed on the rule that red figures of the double scale on *T* gives the equivalent cotangent, provided it is read on the inverted *CI*-scale. It also automatically performs the subtraction.

EXAMPLE.—Solve  $4 \times \tan 10^\circ = x$ .

Set runner to 4 on *D*.

Set index of slide to runner.

Set runner to 10 on *T*.

Read answer .704 under runner on *D*.

EXAMPLE.—Find *x* in the given triangle.

Since 72° is greater than 45°, we shall use the cotangent, set up the problem as a proportion, and read the answer on the *CI* inverted scale.

Then

$$\frac{\cot 72^\circ}{1} = \frac{x}{20}$$

The hairline is set to the red number 72 on *T*; the right-end index is moved to hairline and opposite 2 on *D* read 6.16 on *CI*.

411. The tangent of an angle less than 5° 43' is not given on the *T*-scale of the rule, but since the tangent and the sine for angles less than this have the first three significant figures the same, the *ST*-scale is used instead.

$$\tan 2^\circ 20' = \sin 2^\circ 20' = .0407.$$

412. The Sine Scales *S* and *ST*.—The sine scale is made from the log *L*-scale with numerical values read on the *C*- and *D*-scales. The angle readings start at 5° 43' at the left index and extend to 90° at the right index, which makes it a very useful scale. It is double-numbered in



FIG. 152.

black and red figures similar to the tangent scale, thus giving angles that are complements of each other and useful for cosine factors, which will be explained later.

The *ST*-scale is for angles less than  $5^{\circ} 43'$  and is used for both tangents and sines, as explained in Art. 420.

For the rules graduated to degrees and minutes, the primary divisions up to  $4^{\circ}$  is in minutes, the primary divisions from  $4^{\circ}$  to the end of the scale represent  $10'$ , and the secondary divisions represent  $2'$ . For the rule graduated in degrees and decimals of a degree, the readings are similar to the graduations of all the other scales. The choice of the rule depends upon the nature of the computations required. Electrical engineers may prefer this latter rule.

In reading sines of angles on *S*, the left index of *C* is taken as 0.1, the right index as 1. In using the *ST*-scale, the left index is taken as 0.01 and the right index as 0.1.

EXAMPLE.—Solve  $\frac{81}{\sin 10^{\circ}}$ .

Set runner to 81 on *D*.

Set 10 on *S* to runner.

At index on slide read answer 466. on *D*.

**413. Cosines.**—The cosine of an angle is equal to the sine of the complement of the angle, and, since each number on the scale is a complement of the other, the sine *S*-scale can be used provided scales with opposite colors are read. To illustrate,  $\cos 14^{\circ}$  (red) equals .97 on *C* (black),  $\cos 65^{\circ} 30'$  (red) equals .415 on *C* (black). Since opposite colors must be used and the numerical values are on the black scales *C* and *D*, the red numbers must be used for the angles.

EXAMPLE.—Find the length of the base of the right triangle shown in Fig. 153.



FIG. 153.

$$x = 26 \times \cos 63^{\circ}.$$

SOLUTION.—Set right index to 26 on *D*.

At 63 (red) on *S*, read 11.8 on *D*.

EXAMPLE.—Solve for  $x$  in the following:

$$\text{SOLUTION.—} \frac{4.3 \times 6.1}{\cos 63^{\circ} 35'} = x.$$

Set hairline to 43 on *D*.

Move  $63^{\circ} 35'$  (red) on *S* to hairline.

Move hairline to 61 on *C*.

Opposite 61 on *D*, read  $x = 589$ .

**414. Logarithms.**—By comparing the two scales, *D* and *L* (Art. 384), we have a means of finding the logs which correspond to numbers or a number which corresponds to a given log.

To find the log of a number, set the runner to the number on the *D*-scale, read the mantissa of the log on the *L*-scale, and add the characteristic of the log.

*Conversely*, to find the number corresponding to a given log, set the runner to the mantissa of the log on the *L*-scale and read the number on the *D*-scale. Use the characteristic of the log to locate the decimal point in the number.

**415. General Form.**—The previous articles complete the discussion of the different scales and how they are made, and it has been shown how the slide mechanically adds or subtracts measurements on these various scales which multiply, divide, extract square or cube roots, raise to powers, etc., depending upon which scale measurement is taken.

There are a few simple rules which can be applied to all operations, and a general form will be chosen to illustrate these.

$$\frac{a \times b \times c \times d}{e \times f \times g}$$

If the problem is not in this form, modify it by putting in 1 as additional factors. There should be one more factor in the numerator than in the denominator.

$$\text{Make} \quad \frac{a \times b \times c}{d \times e \times f} = \frac{a \times b \times c \times 1}{d \times e \times f}$$

$$\text{Make} \quad \frac{a \times b \times c}{d} = \frac{a \times b \times c}{d \times 1}$$

The rules are as follows:

1. Arrange the numerator with one more factor than the denominator.
2. The first numerator and the answer are found on the fixed scales of the rule.
3. All other numbers are taken on the slide, whether they are numerators or denominators.
4. The *slide* is moved for each successive divisor.
5. The *runner* is moved for each successive numerator.

EXAMPLE.

$$\frac{D \quad C \quad C \quad C \quad C \quad D}{24.3 \times 612 \times 25.5 \times 9.63 \times 13} = x.$$

$$\frac{C \quad C \quad C \quad C \quad C \quad C}{1.65 \times 7280 \times 4.25 \times 2.34} = x.$$

- Set runner to first numerator 24.3. (2) and (5)  
 Set denominator 165 on slide to runner. (3) and (4)  
 Set runner to second numerator 612. (3) and (5)  
 Set denominator 728 on slide to runner. (3) and (4)  
 Set runner to third numerator 255. (3) and (5)  
 Set denominator 425 on slide to runner. (3) and (4)  
 Set runner to fourth numerator 963. (3) and (5)  
 Set denominator 234 on slide to runner. (3) and (4)  
 Set runner to fifth numerator 13. (3) and (5)  
 Read answer under runner on *D* scale. (2).

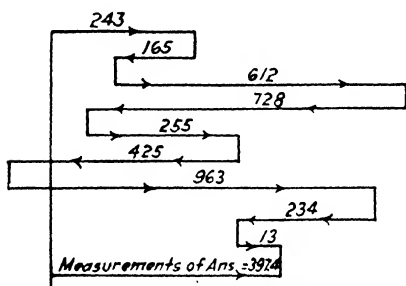

FIG. 154.

This becomes a very simple operation since the runner is moved to each numerator and the slide is moved to each denominator.

A graphical illustration of the foregoing problem which shows the additions of the numerators and the subtractions of the denominators follows.

The answer is the remaining measurement after all the other measurements have been added or subtracted.

#### 416. Reciprocal Forms.

EXAMPLE.

$$\frac{1}{2.24 \times .53 \times 7.81} = x.$$

To put this in the general form, supply the numerator with one more factor than the denominator by introducing unity as factors.

$$\frac{D \quad C \quad C \quad C \quad D}{1 \times 1 \times 1 \times 1} = x.$$

$$\frac{C \quad C \quad C \quad C \quad C}{2.24 \times .53 \times 7.81} = x.$$

- Set runner to numerator 1 on *D*.  
 Set denominator 224 on *C* to runner.  
 Set runner to numerator 1 on *C*.



Set denominator 53 on *C* to runner.  
 Set runner to numerator 1 on *C*.  
 Set denominator 781 on *C* to runner.  
 Set runner to numerator 1 on *C*.  
 Read answer .1075 under runner on *D*.

**417. Expressions with Squared Numbers.**

EXAMPLE.

$$\frac{2.53 \times (54.3)^2 \times 341}{6.7 \times (266)^2}$$

In order to square the numbers which are shown squared, they should be taken on the *C*- and *D*-scales and transferred to the *A*- and *B*-scales, but the other numbers must be measured on the *A*- and *B*-scales; otherwise they would be squared also.

$$\frac{\overset{A}{2.53} \times \overset{C}{(54.3)^2} \times \overset{B}{341}}{\underset{B}{6.7} \times \underset{C}{(266)^2}} = x.$$

Proceeding as in previous case:

Set runner to numerator 253 on *A* (move runner).  
 Set denominator 6.7 on *B* to runner (move slide).  
 Set runner to numerator 543 on *C* (move runner).  
 Set denominator 266 to *C* to runner (move slide).  
 Set runner to numerator 341 on *B* (move runner).  
 Read answer 5.43 on fixed scale *A* under runner.

Note that, as before, the runner is moved to the numerator each time and the slide is moved to the denominator each time. All numbers are taken on the slide except the first numerator and the answer.

**418. Square Root of Expressions.**

EXAMPLE.—Solve

$$\sqrt{\frac{33.1 \times .42 \times 198}{.76 \times 62 \times .09}} = x.$$

By making the operation on the *A*- and *B*-scales and then transferring to the *D*-scale, the square root of the expression is found.

$$\frac{\overset{A}{331} \times \overset{B}{42} \times \overset{B}{198} \times \overset{D}{1}}{\underset{B}{76} \times \underset{B}{62} \times \underset{B}{9}} = x.$$

Set runner to 331 on *A*.

Set 76 on *B* to runner.

Set runner to 42 on *B*.

Set 62 on *B* to runner.

Set runner to 198 on *B*.

Set 9 on *B* to runner.

Set runner to 1 on *B*.

Read answer 25.5 on *D*.

#### 419. Expressions with Square Roots.

EXAMPLE.—Solve

$$\frac{135 \times \sqrt{384} \times 563}{21 \times 332 \times \sqrt{638}} = x.$$

Since we transfer from the *A*- and *B*-scales to the *C*- and *D*-scales to get the square roots of factor, we arrange to measure them on the *A*- and *B*-scales and transfer them to the *C*- and *D*-scales, but take all other factors on *C* and *D*. Then

$$\begin{array}{cccccc} D & & B & & C & & C & & D. \\ \frac{135 \times \sqrt{384} \times 563 \times 1}{21 \times 332 \times \sqrt{638}} = x. \\ C & & C & & B & & & & \end{array}$$

Set runner to numerator 135 on *D* (move runner).

Set denominator 21 on *C* to runner (move slide).

Set runner to numerator 384 on *B* (move runner).

Set denominator 332 on *C* to runner (move slide).

Set runner to numerator 563 on *C* (move runner).

Set denominator 638 on *B* to runner (move slide).

Set runner to numerator 1 on *C* (move runner).

Read answer 8.46 on *D* under runner.

**420. Expressions with Tangents.**—The tangent scale *T* is built to the same unit measurement as the *C*- and *D*-scales, and tangents of angles are found on these scales. The tangent scale extends from left to right in black numbers and from right to left in red numbers, making each number a complement of the other. If the hairline on *T* is set to black 25, its tangent equals the cotangent of the red number 65. The reverse is also true. The tangents are read on *like colors*, and the cotangents are read on *opposite colors*. For instance,  $\tan 25^\circ - 10'$  (black) equals 0.47 on *C* (black),  $\tan 62^\circ - 15'$  (red) equals 0.19 on *CI* (red),  $\cot 15^\circ$  (black) equals 3.73 on *CI* (red), and  $\cot 76^\circ 30'$  (red) equals .240 on *C* (black).

EXAMPLE.—Solve

$$\begin{array}{cccc} D & T & C & C \\ 25 \times \tan 15^\circ \times 42 \times 1 & & & \\ 1.65 \times \tan 20^\circ \times \sqrt{13} & & & \\ C & T & B & \end{array} = x.$$

The scales to be used are indicated above each term, and the same procedure should be followed as in the previous example, that is, alternate the movements of the runner and the slide. In the above example,  $x = 130$ .

For angles smaller than  $5^\circ 43'$ , the *ST*-scale is used as explained in Art. 411.

Square-root factors can readily be computed with the tangent factors since the former are measured on the *A*- and *B*-scales and transferred to the *C*- and *D*-scales, which are the scales used when there is a tangent involved. Squared numbers, since they are transferred to the *A*- and *B*-scales, cannot be used unless the number multiplied by itself is considered as being twice a factor.

#### 421. Expressions with Sines.

EXAMPLE.—Solve

$$\frac{\sqrt{2.66} \times \sin 10^\circ}{14.2 \times .0232} = x.$$

There are two reasons for using the *C*- and *D*-scales for the solving of this example: *first*, the square-root number is measured on the *A*- and *B*-scales and is transferred to the *C*- and *D*-scales; *second*, the sine scale is made from the same unit as the *C*- and *D*-scale. The *S*-scale may be considered the same as a *C*-measurement.

$$\begin{array}{cccc} A & S & C & D \\ \sqrt{2.66} \times \sin 10^\circ \times 1 & & & \\ 14.2 \times .0232 & & & \\ C & C & & \end{array} = x.$$

- Set runner to 266 on *A*.
- Set denominator 142 on *C* to runner.
- Set runner to  $\sin 10^\circ$  on *S*.
- Set denominator 232 on *C* to runner.
- Set runner to 1 on *C*.
- Read answer .859 at runner on *D*.

A square of one of the factors which requires the use of the *A* and *B*-scales for the other factors conflicts with a sine factor

which requires the use of the *C*- and *D*-scales. It is, therefore, advisable to find either the value of the sine or the value of the square of the number before proceeding with the work. This, of course, can be done on the rule.

**422. Power Factors.**—Numbers raised to powers other than squares or cubes can be solved by the log *L*-scale, as indicated by the following examples:

EXAMPLE.—Find  $x = (3.65)^{1.61}$ .

$$\log x = 1.61 \times \log 3.65 = 1.61 \times .5623 = .9053.$$

Opposite 905 on *L*-scale, read 8.04 on *D*.

EXAMPLE.—Find  $x = \sqrt[5]{261}$ .

$$\log x = \frac{1}{5} \times \log 261 = \frac{2.4166}{5} = .4833.$$

Opposite 4833 on *L*-scale, read 3.04 on *D*.

**423. The Exponential Rule.**—Consider the *A*- and *B*-scales as square scales with exponent 2; the *K*-scale, the cube scale with exponent 3; the *C*- and *D*-scales with exponent 1; the *CI*-scale with exponent  $-1$ .

If given

$$x = a^{\frac{n}{m}},$$

first put the exponent in fraction form.

Set  $a$  on a scale having the same exponent as indicated by the denominator  $m$ .

Read answer under the runner on a scale having the same exponent as indicated by the numerator.

Briefly, set number on denominator scale and read answer on numerator scale.

Given

$$x = a^2 = a^{\frac{2}{1}}.$$

The number  $a$  is set on the *D*-scale, which has an exponent 1 as indicated by the denominator of the exponent.

The answer is read on the *A*-scale, which has an exponent 2 as indicated by the numerator.

Given

$$x = \sqrt{a} = a^{\frac{1}{2}}.$$

Set runner to  $a$  on the *A*-scale, the exponent 2 scale.

Read answer under the runner on the *D*-scale, the exponent 1 scale.

Given

$$x = \sqrt[3]{a} = a^{\frac{1}{3}}.$$

Set runner at  $a$  on the *K*-scale, the exponent 3 scale.

Read answer ( $\sqrt[3]{a}$ ) on *D*-scale, or exponent 1 scale.

Given

$$x = \sqrt[3]{a^2} = a^{\frac{2}{3}}.$$

Set runner at  $a$  on the *K*-scale, or exponent 3 scale.

Read answer on *A*-scale, or exponent 2 scale.

Given

$$x = \sqrt{a^3} = a^{\frac{3}{2}}.$$

Set runner to  $a$  on *A*.

Read answer ( $\sqrt{a^3}$ ) on *K* under the runner.

Given

$$x = \frac{1}{\sqrt{a}} = a^{-\frac{1}{2}} = a^{\frac{-1}{2}}.$$

Set runner to  $a$  on *A*.

Read answer ( $\frac{1}{\sqrt{a}}$ ) under the runner on the *CI*-scale, or exponent  $-1$  scale.

Index of slide must be in alignment with the index of the *A*-scale.

Given

$$x = \pi\sqrt{a} = \pi \times a^{\frac{1}{2}}.$$

To get  $x = \sqrt{a}$ .

Set runner to  $a$  on *A*.

Read answer on *D*.

To multiply by  $\pi$ , transfer reading from *D* to *DF*.

Given

$$x = \frac{1}{a^3} = a^{-3} = a^{\frac{-3}{1}}.$$

Set runner to  $a$  on *CI*.

Read answer on *K*.

Given

$$x = \frac{1}{\pi\sqrt{a}} = a^{\frac{-1}{2}} \times \frac{1}{\pi}$$

Set runner to  $a$  on  $A$ -scale.

Read answer under the runner on  $CIF$ .

The  $-1$  indicates an inverted scale, and by reading on the folded scale the result is divided by  $\pi$ .

**424. Solution of Right Triangles.**—The sine law [90] which has the form,

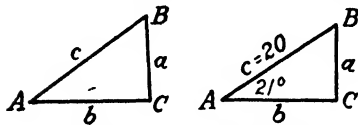

FIG. 155.

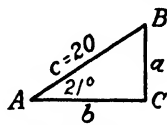

FIG. 156.

$$[90] \frac{a}{\sin A} = \frac{b}{\sin B} = \frac{c}{\sin C}$$

is very convenient for solving right, as well as oblique, triangles. For right triangles the formula takes the form

$$\frac{a}{\sin A} = \frac{b}{\sin B} = \frac{c}{1}, \quad \text{since } C = 90^\circ \text{ and } \sin C = 1.$$

One of the three ratios always permits a setting of the rule. Other angles or sides can be read by moving the hairline to any known quantity in the other ratios.

**EXAMPLE.**—Let  $A = 35^\circ 30'$  and  $b = 15$  in Fig. 155 to find  $a$ ,  $c$ , and  $B$ . Then

$$\frac{\text{Scale } D}{\text{Scale } S} = \frac{b = 15}{\sin (90^\circ - 35^\circ 30')} = \frac{a}{\sin 35^\circ 30'} = \frac{c}{1}.$$

**SOLUTION.**—Set hairline to 15 on  $D$ . Move  $54^\circ 30'$  on  $S$  to hairline. Opposite  $35^\circ 30'$  on  $S$ , read  $a = 10.7$ , and, opposite index on  $S$ , read  $c = 18.4$ .

**EXAMPLE.**—Given  $A = 21^\circ$ ,  $c = 20$ , as shown in Fig. 156. Find  $a$ ,  $b$ , and  $B$ .

$$\frac{D}{S} = \frac{20}{1} = \frac{a}{\sin 21^\circ} = \frac{b}{\sin (90^\circ - 21^\circ)}.$$

**SOLUTION.**—Set hairline to 20 on  $D$ . Set index on  $S$  to hairline. At  $21$  on  $S$ , read  $a = 7.17$  on  $D$ , and, at  $69$  on  $S$ , read  $b = 18.7$  on  $D$ .

**425. Oblique Triangles.**—There are two convenient trigonometric formulae that may be used in the solution of oblique triangles.

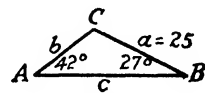

FIG. 157.

If given two angles and a side or two sides and the angle opposite to one of them, use the law of sines [90].

$$\frac{D}{S} = \frac{a}{\sin A} = \frac{b}{\sin B} = \frac{c}{\sin C} = \frac{c}{\sin (A + B)}$$

EXAMPLE.—Let  $a = 25$ ,  $A = 42^\circ$ ,  $B = 27^\circ$ .  
Find  $b$ ,  $c$ , and  $C$ .

$$C = 180^\circ - (42^\circ + 27^\circ) = 111^\circ.$$

$$\frac{D}{S} = \frac{25}{\sin 42^\circ} = \frac{b}{\sin 27^\circ} = \frac{c}{\sin 111^\circ} = \frac{c}{\sin 69^\circ}.$$

$$\frac{D}{S} = \frac{25}{\sin 42^\circ} = \frac{b = 17.0}{\sin 27^\circ} = \frac{c = 35}{\sin 69^\circ}.$$

**426.** If given two sides and the included angle which is greater than  $90^\circ$ , use the formula,

[91] 
$$\frac{T}{D} = \frac{\tan \frac{1}{2}(A + B)}{(a + b)} = \frac{\tan \frac{1}{2}(A - B)}{(a - b)}$$

and the law of sines.

EXAMPLE.—Given  $C = 116^\circ$ ,  $b = 21$ ,  $a = 51$ .  
Find  $A$ ,  $B$ , and  $c$ .

Use 
$$\frac{\tan \frac{1}{2}(A + B)}{(a + b)} = \frac{\tan \frac{1}{2}(A - B)}{(a - b)}. \quad [91.]$$

$$\frac{1}{2}(A + B) = \frac{180^\circ - 116^\circ}{2} = 32^\circ.$$

$$a + b = 72.$$

$$a - b = 30.$$

Substituting,

$$\frac{\tan 32^\circ}{72} = \frac{\tan \frac{1}{2}(A - B)}{30}$$

$$\frac{1}{2}(A + B) = 32^\circ$$

$$\frac{1}{2}(A - B) = 14^\circ 3'$$

$$A = 46^\circ 3'$$

$$B = 64^\circ - 46^\circ 3' = 17^\circ 57'.$$

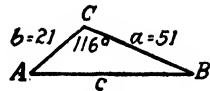

FIG. 158.

From

$$\frac{a}{\sin A} = \frac{c}{\sin C} [90],$$

$$\frac{D}{S} = \frac{51}{\sin 46^\circ 3'} = \frac{c = 63.8}{\sin 116^\circ} = \frac{c}{\sin 64^\circ}.$$

**427.** If given two sides and the included angle which is less than  $90^\circ$ :

In this case,  $\frac{1}{2}(A + B)$  is greater than  $45^\circ$  and a modified form of the law of tangents is used. By using the formula,

$$\tan A = \frac{1}{\tan (90^\circ - A)},$$

formula [91] becomes

$$[92] \quad \frac{1}{(a+b)(\tan [90^\circ - \frac{1}{2}\{A+B\}])} = \frac{\tan \frac{1}{2}(A-B)}{(a-b)},$$

which should be used with

$$\frac{a}{\sin A} = \frac{b}{\sin B} = \frac{c}{\sin C}. \quad [90.]$$

EXAMPLE.—Given  $C = 80^\circ$ ,  $a = 130$ ,  $b = 100$ .  
To find  $A$ ,  $B$ , and  $c$ .

$$a + b = 230.$$

$$a - b = 30.$$

$$\frac{1}{2}(A + B) = \frac{180^\circ - 80^\circ}{2} = 50^\circ.$$

From [92],

$$\frac{1}{230 \times \tan 40^\circ} = \frac{1}{193} = \frac{\tan \frac{1}{2}(A - B)}{30}.$$

$$\frac{1}{2}(A - B) = 8^\circ 50'.$$

$$\frac{1}{2}(A + B) = 50^\circ$$

$$\frac{1}{2}(A - B) = 8^\circ 50'$$

$$A = 58^\circ 50'$$

$$B = 100^\circ - 58^\circ 50' = 41^\circ 10'.$$

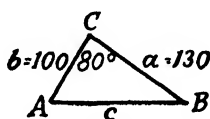

FIG. 159.

From [90],

$$\frac{a}{\sin A} = \frac{c}{\sin C}.$$

$$\frac{130}{\sin 58^\circ 50'} = \frac{c}{\sin 80^\circ}.$$

$$c = 151.$$

**428. Slide-rule Correction Method.**—If one of two numbers is too large for the slide rule, it can be separated into two parts, and each part multiplied by the other number with one setting on the slide. The addition of the two products increases the



accuracy of the result beyond the usual range of the slide rule without requiring much time or effort.

Expressed algebraically,

$$(a + b)c = ac + bc.$$

EXAMPLE.—Multiply  $527.85 \times 3.14$ .

The number 527.85 is beyond the range of the slide rule and we, therefore, arrange it as

$$(527 + .85)3.14 = 527 \times 3.14 + .85 \times 3.14.$$

Take the smaller number 3.14 on the fixed *D*-scale and set the index to 3.14. The products  $527 \times 3.14$  and  $.85 \times 3.14$  are found by simply moving the runner, and the main part of the answer corrected by the addition of the second product or

$$1655 + 2.00 = 1657.00.$$

The correct value is 1657.449, while the regular slide-rule product would be 1655.

RULE.—Take three significant figures of each number. The fourth significant figure is uncertain. Disregard all figures beyond the fourth figure.

429. If both numbers are beyond the range of the slide rule, then algebraically.

$$(a + b)(c + d) = (a + b)c + (a + b)d.$$

This requires two settings each similar to the preceding case.

EXAMPLE.—Multiply 45,681 by 38,266 using 20' slide rule.

$$(45,600 + 81)38,200 + (45,600 + 81)66.$$

Index at 382 on *D*  $\left\{ \begin{array}{l} 1,742,000,000 \\ 3,000,000 \end{array} \right.$

Index at 66 on *D*  $\left\{ \begin{array}{l} 3,000,000 \\ \hline 1,748,000,000 \end{array} \right.$

Actual product is 1,748,029,146.

Regular slide-rule reading is 1,750,000,000.

## CHAPTER XVIII

### INFINITE SERIES

**430. Infinite Series.**—In Art. 298 *et seq.*, we saw that a series was a succession of terms formed according to some law of succession and continuing to any finite number of terms. We developed formulæ for finding the sum of any finite number of these terms. We now desire to investigate series which have no such limitation placed upon the number of terms considered. Such a series, in which the number of terms  $n$  is allowed to increase without limit is called an *infinite series*.

**431.** In Art. 313, it was shown that the sum of  $n$  terms of a geometric series  $S_n$  approaches a limiting value when  $r$  is numerically less than unity and the number of terms  $n$  is allowed to increase without bound. That is, by taking a sufficient number of terms, we may obtain a value for  $S_n$  which differs from this limiting value by as little as we please. It was also seen that in the case of the arithmetical series, no such limiting value for  $S_n$  exists, and that as the number of terms is increased, the sum of these terms either increases or decreases without bound.

**432.** If  $u_1, u_2, u_3 \dots$  represents a set of values, positive or negative, or both, arranged in a series,

$$u_1 + u_2 + u_3 + \dots + u_n + u_{n+1} + \dots$$

according to some law of succession, we denote the sum of the first  $n$  terms by  $S_n$ .

$$S_n = u_1 + u_2 + u_3 + \dots + u_n.$$

Now if  $n$  is allowed to increase without limit, either

**Case 1**  $S_n$  approaches some finite number as a limit, or

**Case 2**  $S_n$  does not approach a limit.

In Case 1 we represent the limit of  $S_n$  by  $S$ , or symbolically,

$$\lim_{n \rightarrow \infty} S_n = S$$

and the series is said to be convergent upon  $S$ , or to converge to  $S$ , or to have the sum  $S$ , or to be convergent and have the value  $S$ . Such series are convergent series and these are the infinite series which are most useful in practice.

**433. Non-convergent Series.**—In Case 2 the series is said to be non-convergent. Here must be considered two classes:

1. *Divergent series*, in which  $S_n$  increases in absolute value without limit as  $n$  increases without bound.

2. *Oscillating series*, in which  $S_n$  does not become infinite in absolute value as  $n$  increases without bound, and which do not converge to a limit but *oscillate*, as in

$$S_n = 1 - 1 + 1 - 1 + \dots + (-1)^{n-1}.$$

In this case,  $S_n$  is either zero or unity, according as  $n$  is even or odd.

**EXAMPLE OF CONVERGENT SERIES.**—Consider the geometric series,  
Sum =  $S_n = a + ar + ar^2 + ar^3 + \dots + ar^{n-1} + \dots$

$$S_n = \frac{a(1 - r^n)}{1 - r}.$$

Let  $a = 1, r = \frac{1}{2}$ .

The series becomes

$$S_n = 1 + \frac{1}{2} + \frac{1}{4} + \frac{1}{8} + \frac{1}{16} + \dots + \frac{1}{2^{n-1}} + \dots$$

$$S_n = \frac{1 - \frac{1}{2^n}}{1 - \frac{1}{2}} = 2 - \frac{1}{2^{n-1}}.$$

As  $n$  increases without limit,  $\frac{1}{2^{n-1}}$  approaches 0 as a limit, and

$$\lim_{n \rightarrow \infty} S_n = 2.$$

$$S_1 = 1.$$

$$S_2 = 1 + \frac{1}{2} = \frac{3}{2}.$$

$$S_3 = 1 + \frac{1}{2} + \frac{1}{4} = \frac{7}{4}.$$

$$S_4 = 1 + \frac{1}{2} + \frac{1}{4} + \frac{1}{8} = \frac{15}{8}.$$

It is evident that as  $n$  increases,  $S_n$  can be made to come close at will to 2, that is, to differ from 2 by less than any assigned number, however small.

**EXAMPLE OF DIVERGENT SERIES.**—Consider the arithmetic series,

$$\text{Sum} = S_n = 1 + 2 + 3 + 4 + \dots + n = \frac{n}{2}(1 + n).$$

$$S_1 = 1.$$

$$S_2 = 1 + 2 = 3.$$

$$S_3 = 1 + 2 + 3 = 6.$$

$$S_4 = 1 + 2 + 3 + 4 = 10.$$

It is evident that as  $n$  increases without bound,  $S_n$  increases without limit and the series is divergent.

434. Infinite series are sometimes represented by the  $n$ th or general term,  $u_n = \frac{n+1}{n}$  indicating the series, as

$$\frac{2}{1} + \frac{3}{2} + \frac{4}{3} + \dots + \frac{n+1}{n}$$

The limit of a convergent series is represented by

$$\lim_{n \rightarrow \infty} S_n = S.$$

435. The nature of an infinite series is not changed by prefixing or removing a finite number of terms; that is, a series will remain convergent or divergent or oscillating if terms are added or removed, although the limit to which a convergent series will converge will, in general, be changed by the process.

A series may be given for which the sum  $S_n$  cannot be found as it was found in the case of the geometric series, and we may not be able to find the numerical value of the limit, but it is necessary in any operation with series to know that a limit exists. In determining whether a series is convergent, it must be examined according to the following theorems:

436. If  $S_n$  always *increases* as  $n$  increases but always remains less than some fixed number  $K$ , then as  $n$  increases beyond bound,  $S_n$  approaches a limit which is not greater than  $K$ .

437. If  $S_n$  always *decreases* as  $n$  increases but always remains greater than some fixed number  $M$ , then as  $n$  increases beyond bound,  $S_n$  approaches a limit which is not less than  $M$ .

438. **Series Whose Terms are All Positive.**—A series whose terms are all positive cannot oscillate.  $S_n$  will always increase in such a series, and if it can be shown that this sum always remains less than some finite number, the series must be convergent (Art. 436). On this principle is based the following test:

439. **The Comparison Test for Convergence.**—If

$$u_1 + u_2 + u_3 + \dots \tag{1}$$

is a series of positive terms which we desire to test for convergence, and

$$v_1 + v_2 + v_3 + \dots \tag{2}$$

is a series which is known to be convergent, then, if each term of (1) is less than the corresponding term of (2), the series (2) is convergent and its limiting value cannot be greater than the limiting value of (1).

**EXAMPLE.**—Prove that the series,

$$2 + 1 + \frac{1}{2^2} + \frac{1}{3^3} + \frac{1}{4^4} + \dots + \frac{1}{(n-1)^{n-1}} + \dots, \quad (1)$$

is convergent.

We will compare with the geometrical series,

$$2 + 1 + \frac{1}{2^2} + \frac{1}{2^3} + \frac{1}{2^4} + \dots + \frac{1}{2^{n-1}} + \dots \quad (2)$$

Comparing, we find that after the third terms, each term of the  $u$  series (1) is less than the corresponding term of the  $v$  series (2). After we have examined several terms, we must not fail to examine the  $n$ th terms.

If  $n > 3$ ,

$$\frac{1}{(n-1)^{n-1}} < \frac{1}{2^{n-1}}.$$

$S_n$  in (2) after the third term can never exceed  $\frac{1}{2}$  since the series converges towards  $3\frac{1}{2}$ .  $S_n$  in (1) after the third term is less than  $S_n$  in (2) and (1), therefore, converges to some number  $K < 3\frac{1}{2}$ .

**440. A Few Useful Series for Testing Convergence.**—It can be proved that the following series are convergent:

$$a + ar + ar^2 + ar^3 + ar^4 + \dots + ar^{n-1} + \dots$$

where  $-1 < r < 1$ .

$$\sqrt{\frac{1}{1 \cdot 2} + \frac{1}{2 \cdot 3} + \frac{1}{3 \cdot 4} + \frac{1}{4 \cdot 5} + \dots + \frac{1}{n(n+1)} + \dots}$$

$$1 + \frac{1}{2^p} + \frac{1}{3^p} + \frac{1}{4^p} + \frac{1}{5^p} + \dots + \frac{1}{n^p} + \dots$$

where  $p > 1$ .

**441. Comparison Test for Divergence.**—If

$$u_1 + u_2 + u_3 + u_4 + \dots + u_n + \dots \quad (1)$$

is a series to be tested for divergence, and we can find a series of positive terms already known to be divergent,

$$v_1 + v_2 + v_3 + v_4 + \dots + v_n + \dots \quad (2)$$

whose terms are never greater than the corresponding terms of (1), then (1) is a divergent series.

One of the most important series for testing divergence is the harmonic series,

$$1 + \frac{1}{2} + \frac{1}{3} + \frac{1}{4} + \frac{1}{5} + \dots + \frac{1}{n} + \dots$$

This series can be shown to be divergent in the following manner:

Group the terms so that the sum of the terms in each group is greater than  $\frac{1}{2}$ , thus,

$$1 + \frac{1}{2} + \left(\frac{1}{3} + \frac{1}{4}\right) + \left(\frac{1}{5} + \frac{1}{6} + \frac{1}{7} + \frac{1}{8}\right) + \dots$$

In the first group will be two terms, in the second, four, in the third, eight, and so on.

In the first group,  $\frac{1}{3} > \frac{1}{4}$  and their sum is greater than two times  $\frac{1}{4}$ , or  $\frac{1}{2}$ . In the second group, the sum of the terms is greater than four times  $\frac{1}{8}$ , or  $\frac{1}{2}$ . We can thus arrange an unlimited number of groups each greater than  $\frac{1}{2}$ , and the sum of these groups, that is, the sum of the series, can be made great at will, and the series is divergent since by taking  $n$  large enough, the sum can be made to exceed any assignable number, however large.

EXAMPLE.—Examine for divergence the series,

$$\frac{1}{\sqrt{2}} + \frac{1}{\sqrt{3}} + \frac{1}{\sqrt{4}} + \frac{1}{\sqrt{5}} + \dots + \frac{1}{\sqrt{n}} + \dots \quad (1)$$

Compare with the divergent harmonic series,

$$\frac{1}{2} + \frac{1}{3} + \frac{1}{4} + \frac{1}{5} + \dots + \frac{1}{n} + \dots \quad (2)$$

Since the denominator of each term in (1) is less than the corresponding denominator in (2), each term of (1) is greater than the corresponding term of (2), and (1) diverges also.

**442.** The following series are important in testing for divergence:

The geometric series,

$$a + ar + ar^2 + ar^3 + ar^4 + \dots + ar^{n-1} + \dots$$

where  $r \geq 1$ .

And the harmonic series,

$$1 + \frac{1}{2} + \frac{1}{3} + \frac{1}{4} + \frac{1}{5} + \frac{1}{6} + \dots + \frac{1}{n} + \dots$$

It is a very good plan to keep for future reference a list of all of the series that are found to be convergent or divergent, so that they will be available for purposes of comparison when needed. The blank space reserved here is for this purpose.

**443. The Ratio Test for Convergence.**—The ratio of the  $(n + 1)$ st term of a series to the  $n$ th term is called the *ratio of convergence*. The nature of a series can generally be determined from an inspection of this ratio,

$$\frac{u_{n+1}}{u_n},$$

and its behavior as  $n$  is allowed to increase without limit. The geometric series has a constant value for this ratio, regardless of the value of  $n$ , as was seen in Art. 313 where the limit of the sum was obtained from the straight-line graph.

Consider the series,

$$u_1 + u_2 + u_3 + u_4 + \dots + u_n + u_{n+1} + \dots$$

in which the terms may be all positive, or all negative, or both positive and negative. Form the ratio,  $\frac{u_{n+1}}{u_n}$ , and allow  $n$  to increase without limit.

The *absolute* value of this ratio,  $\left| \frac{u_{n+1}}{u_n} \right|$ , as  $n$  increases without bound will, in general, approach a definite limiting value or it will increase without limit. Call the limit, if it exists,  $\rho$ . If  $\rho < 1$ , the series is convergent.

$\rho > 1$ , the series is divergent.

$\rho = 1$ , the test fails to give us any information and the series may be either convergent or divergent.

EXAMPLES.—Test the series by means of the ratio test.

$$\frac{1}{2} + \frac{2}{2^2} + \frac{3}{2^3} + \frac{4}{2^4} + \dots + \frac{n}{2^n} + \dots$$

$$u_{n+1} = \frac{n+1}{2^{n+1}}, \quad u_n = \frac{n}{2^n}$$

$$\frac{u_{n+1}}{u_n} = \frac{n+1}{2^{n+1}} \cdot \frac{2^n}{n} = \frac{n+1}{2n} = \frac{n}{2n} + \frac{1}{2n} = \frac{1}{2} + \frac{1}{2n}$$

$$\text{Limit}_{n \rightarrow \infty} \frac{u_{n+1}}{u_n} = \text{Limit}_{n \rightarrow \infty} \left( \frac{1}{2} + \frac{1}{2n} \right) = \frac{1}{2}$$

$\frac{1}{2} < 1$ . Therefore, the series is convergent.

**EXAMPLE.**—Test for convergence,

$$\frac{2}{2^2} + \frac{2^2}{3^2} + \frac{2^3}{4^2} + \frac{2^4}{5^2} + \dots + \frac{2^n}{(n+1)^2} + \dots$$

$$\frac{u_{n+1}}{u_n} = \frac{2^{n+1}}{(n+2)^2} \cdot \frac{(n+1)^2}{2^n} = 2 \left( \frac{n+1}{n+2} \right)^2.$$

$$\text{Limit}_{n \rightarrow \infty} \frac{u_{n+1}}{u_n} = 2.$$

$2 > 1$ . Therefore, the series is divergent.

**444. Proof of Cauchy's Ratio Test for Convergence.**—Consider the series of positive terms,

$$u_1 + u_2 + u_3 + u_4 + \dots$$

which we desire to test for convergence.

Form the test ratio,

$$\frac{u_{n+1}}{u_n},$$

by dividing any general term by the term that precedes it.

This ratio will, in general, approach a limit as  $n$  is allowed to increase without limit. If the ratio fails to approach a definite fixed number as a limit, the test of the series cannot be made in this manner. If the ratio does approach a definite limiting value as  $n$  increases without bound, let this limit be represented by  $\rho$ . Symbolically,

$$\text{Limit}_{n \rightarrow \infty} \frac{u_{n+1}}{u_n} = \rho.$$

This limit will be less than, greater than, or equal to 1. That is,  $\rho < 1$ ,  $\rho > 1$ , or  $\rho = 1$ .

**445. Case 1.  $\rho < 1$ .**—If the limit of the ratio  $\frac{u_{n+1}}{u_n} = \rho$  is less than 1 as  $n$  increases, the values of the ratio cluster about the value  $\rho$  and it will be possible to choose some number  $r$  which lies between  $\rho$  and 1, which will be greater than all values of the ratio,  $\frac{u_{n+1}}{u_n}$ , for any  $n$  subsequent to a certain  $n$ , as  $n = m$ , or for all values of  $n > m$ ,

$$\frac{u_{n+1}}{u_n} < r.$$



Or

$$\begin{aligned} n = m, & \quad \frac{u_{m+1}}{u_m} < r, & u_{m+1} < u_m r, \\ n = m + 1, & \quad \frac{u_{m+2}}{u_{m+1}} < r, & u_{m+2} < u_{m+1} r < u_m r^2, \\ n = m + 2, & \quad \frac{u_{m+3}}{u_{m+2}} < r, & u_{m+3} < u_{m+2} r < u_m r^3, \\ n = m + 3, & \quad \frac{u_{m+4}}{u_{m+3}} < r, & u_{m+4} < u_{m+3} r < u_m r^4. \end{aligned}$$

Adding  $p$  of these inequalities,

$$\begin{aligned} u_{m+1} + u_{m+2} + u_{m+3} + u_{m+4} + \dots + u_{m+p} \\ < u_m(r + r^2 + r^3 + r^4 + \dots + r^p). \end{aligned}$$

It will be seen that the terms in the parenthesis form a geometric series in which  $r < 1$ , and this series we have already shown to be convergent. The sum is always less than

$$u_m \frac{r}{1 - r}.$$

Consequently, the sum of the series,

$$u_{m+1} + u_{m+2} + u_{m+3} + u_{m+4} + \dots + u_{m+p},$$

can never exceed in value

$$u_m \frac{r}{1 - r},$$

which is a definite fixed number, and the  $u$  series, therefore, converges.

**446. Case 2.  $\rho > 1$ .**—This case is treated in the same manner as the case where  $\rho < 1$ , except that  $r$  in this case will be greater than 1, which causes the geometric series to diverge.

**447. Case 3.**—In order to prove that the ratio test fails when  $\rho = 1$ , it is necessary to consider the series,

$$1 + \frac{1}{2^p} + \frac{1}{3^p} + \frac{1}{4^p} + \frac{1}{5^p} + \dots + \frac{1}{n^p} + \dots \quad (1)$$

Consider  $p$  to be greater than 1.

Group the terms,

$$\frac{1}{2^p} + \frac{1}{3^p} < \frac{1}{2^p} + \frac{1}{2^p} = \frac{2}{2^p} = \frac{1}{2^{p-1}}.$$

$$\frac{1}{4^p} + \frac{1}{5^p} + \frac{1}{6^p} + \frac{1}{7^p} < \frac{1}{4^p} + \frac{1}{4^p} + \frac{1}{4^p} + \frac{1}{4^p} = \frac{4}{4^p} = \left(\frac{1}{2^{p-1}}\right)^2.$$

$$\frac{1}{8^p} + \dots + \frac{1}{15^p} < \frac{1}{8^p} + \frac{1}{8^p} + \frac{1}{8^p} + \frac{1}{8^p} + \frac{1}{8^p} + \frac{1}{8^p} + \frac{1}{8^p} + \frac{1}{8^p} = \frac{8}{8^p} = \left(\frac{1}{2^{p-1}}\right)^3.$$

If the grouping of terms is continued in the manner indicated, and if we form a series from the right-hand members of the inequalities, we have the series,

$$1 + \frac{1}{2^{p-1}} + \left(\frac{1}{2^{p-1}}\right)^2 + \left(\frac{1}{2^{p-1}}\right)^3 + \dots + \left(\frac{1}{2^{p-1}}\right)^{n+1} + \dots \quad (2)$$

When  $p > 1$ , the series (2) is a geometric series having the common ratio less than unity and we have already seen that such a series is convergent. The sum of the series (1) is less than the sum of the series (2) as was shown by the inequalities above, and series (1) is, therefore, convergent.

When  $p = 1$ , the series (1) becomes the harmonic series which we have already shown to be divergent.

When  $p < 1$ , each term of the series (1) will be greater than the corresponding term of the harmonic series, and in this case the series will be divergent.

**448.** Returning now to a consideration of the ratio test and its failure to indicate the nature of the series to which it is applied when the limit of the ratio  $\rho$  is equal to 1, we form the test ratio for the series (1),

$$1 + \frac{1}{2^p} + \frac{1}{3^p} + \frac{1}{4^p} + \frac{1}{5^p} + \dots + \frac{1}{n^p} + \frac{1}{(n+1)^p} + \dots$$

The test ratio is

$$\frac{u_{n+1}}{u_n} = \left(\frac{n}{n+1}\right)^p = \left(\frac{n+1}{n}\right)^{-p} = \left(1 + \frac{1}{n}\right)^{-p}.$$

$$\text{Limit}_{n \rightarrow \infty} \left(\frac{u_{n+1}}{u_n}\right) = \rho = \text{Limit}_{n \rightarrow \infty} \left(1 + \frac{1}{n}\right)^{-p} = (1)^{-p}.$$

Hence, we see that  $\rho = 1$  for this series, regardless of the value of  $p$ . But we have already shown that when  $p > 1$ , this series converges, and when  $p < 1$ , this series diverges. There-

fore, the ratio test fails in the case where  $\rho = 1$ , since the limit of the ratio may be equal to 1 for both convergent and divergent series.

**449.** It is not a sufficient condition for convergence of series of positive terms that the value of the ratio,  $\frac{u_{n+1}}{u_n}$ , becomes and remains less than 1 for all values of  $n$ , for in the case of the harmonic series this condition is fulfilled and yet the series is divergent.

The limit of the ratio must be *less* than 1, whereas the limit of the ratio in the case of the harmonic series *equals* 1 and we have seen that the test fails in this case.

**450. Series Whose Terms Are All Negative.**—The theorems which we have developed for the treatment of series whose terms are all positive may be developed, with modifications, so as to apply to series all of whose terms are negative, by the use of the fundamental theorem of Art. 437 as a basis instead of Art. 436 which we have used.

**451. Series Which Have Both Positive and Negative Terms.**—If the number of negative terms is finite, they may be neglected and the resulting series tested for convergence according to the foregoing articles. If the number of positive terms is finite, these may be neglected and the resulting series of negative terms may be tested. It is evident that the neglecting of terms in this manner affects the value, but not the existence of the limit of the sum, and, if such a limit exists, the series is convergent although it converges to a different value.

If a series consists of an infinite number of both positive and negative terms, we may investigate to determine its nature using the theorem:

*An infinite series which is composed of an infinite number of positive and an infinite number of negative terms is convergent if the series formed by taking the absolute values of all the terms is convergent.*

Suppose that the given series is

$$u_1 + u_2 + u_3 + u_4 + \dots \quad (1)$$

and that the series deduced from the given series by making all of its terms positive is

$$|u_1| + |u_2| + |u_3| + |u_4| + \dots \quad (2)$$

The series (2) is convergent and its sum  $S_n$  approaches some definite fixed number as a limit. Let this number be  $S$ . Then

$$\lim_{n \rightarrow \infty} S_n = S.$$

$S_n$  of the original series is, then, always less in absolute value than  $S$ , since the sum obtained by taking  $n$  terms all positive is less than  $S$ .

Suppose that the  $n$  terms of (1) are composed of  $p$  positive and  $q$  negative terms; then

$$S_n(\text{in } 2) = P_p + N_q,$$

where  $P_p$  is the sum of the  $p$  positive terms and  $-N_q$  is the sum of the  $q$  negative terms. Also,

$$S_n(\text{in } 1) = P_p - N_q.$$

Now, since series (2) is convergent and its sum can never exceed  $S$ , and because  $P_p$  and  $N_q$  are both positive while their sum never exceeds  $S$  (which means that  $P_p$  approaches a limiting value  $P$ , and  $N_q$  approaches a limiting value  $N$ ), it is apparent that

$$\lim_{n \rightarrow \infty} S_n(\text{in } 1) = P - N = \text{a definite fixed number.}$$

Therefore, the series (1) is convergent according to the definition of convergence.

Series of this sort, which are not only convergent but are also convergent if the absolute value of the terms is considered, are said to be *absolutely convergent*.

Series which consist of positive and negative terms may be convergent although the series deduced from them by considering the absolute value of each term is not convergent. Series of this type are said to be *conditionally convergent*.

**452. The ratio test** (Art. 443 *et seq.*) can be applied to series of positive and negative terms as follows:

The series,

$u_1 + u_2 + u_3 + u_4 + \dots$  ( $u_n$  either positive or negative), is convergent if

$$\lim_{n \rightarrow \infty} \left| \frac{u_{n+1}}{u_n} \right| < 1.$$

This follows directly from (Art. 451).

The series is divergent if

$$\lim_{n \rightarrow \infty} \left| \frac{u_{n+1}}{u_n} \right| > 1.$$

For if the limit of the ratio is greater than unity,  $u_n$  cannot approach the limit zero, and consequently the series cannot be convergent since the condition that  $u_n$  approach zero as a limit is a necessary one for convergence.

The test fails if

$$\text{Limit}_{n \rightarrow \infty} \left| \frac{u_{n+1}}{u_n} \right| = 1.$$

The proof for this assertion is the same as has already been given (Art. 448).

**453. Alternating Series.**—An alternating series is one whose terms are alternately positive and negative. The theorems developed for the investigation of series whose terms are both positive and negative are, of course, valid in the case of an alternating series. In addition we have the following theorem that applies to alternating series:

*If  $u_1, u_2, u_3, \dots$  are positive terms and they are arranged in an alternating series, as*

$$u_1 - u_2 + u_3 - u_4 + u_5 - u_6 + \dots + (-1)^{n-1}u_n + \dots$$

*so that each term is less than the term that precedes it, in numerical value, and if*

$$\text{Limit}_{n \rightarrow \infty} u_n = 0,$$

*then the series is convergent.*

The sum of  $2n$  (an even number) terms of the series is

$$S_{2n} = (u_1 - u_2) + (u_3 - u_4) + (u_5 - u_6) + \dots + (u_{2n-1} - u_{2n}), \quad (1)$$

or

$$S_{2n} = u_1 - (u_2 - u_3) - (u_4 - u_5) - \dots - u_{2n}. \quad (2)$$

The quantities in the parentheses are all positive, since each term is less than the one that precedes it, in absolute value.

Therefore, we see from (1) that  $S_{2n}$  is positive and always increases as  $n$  increases.

Moreover, we see from (2) that  $S_{2n}$  is always less than  $u_1$ .

Sum of an odd number of terms is

$$S_{2n+1} = S_{2n} + u_{2n+1}. \quad \text{Hence,}$$

$\text{Limit } S_{2n+1} = \text{Limit } S_{2n} + \text{Limit } u_{2n+1}$ . But  $\text{Limit } u_{2n+1}$  is zero by hypothesis; hence,  $S_{2n+1}$  has the same limit as  $S_{2n}$ . Therefore,  $S_n$ , the sum of any number of terms, odd or even, approaches this same limit.

**EXAMPLE.**—The series,

$$1 - \frac{1}{2} + \frac{1}{3} - \frac{1}{4} + \frac{1}{5} - \frac{1}{6} + \dots + (-1)^{n-1} \cdot \frac{1}{n} + \dots$$

is convergent since each term is less in absolute value than the term that precedes it, and

$$\text{Limit}_{n \rightarrow \infty} (u_n) = \text{Limit}_{n \rightarrow \infty} \left( \frac{1}{n} \right) = 0.$$

If the positive values only of the terms are considered, this series is divergent, for it is then the harmonic series which we have already shown to be divergent. This series is an example of conditionally convergent series.

The series,

$$1 - \frac{1}{2^2} + \frac{1}{3^3} - \frac{1}{4^4} + \frac{1}{5^5} - \frac{1}{6^6} + \dots + (-1)^n \frac{1}{n^n} + \dots$$

is absolutely convergent because the series,

$$1 + \frac{1}{2^2} + \frac{1}{3^3} + \frac{1}{4^4} + \frac{1}{5^5} + \frac{1}{6^6} + \dots + \frac{1}{n^n} + \dots$$

is convergent.

**454. Directions for Testing Series.**—Suppose that we have the series,

$$u_1 + u_2 + u_3 + u_4 + u_5 + \dots + u_n + \dots$$

which we desire to test for convergence.

If it is an alternating series in which each term is less in absolute value than the term that precedes it, and

$$\text{Limit}_{n \rightarrow \infty} (u_n) = 0,$$

then the series is convergent.

If it is not an alternating series satisfying these conditions, determine the law of formation of the terms and form the ratio of  $u_{n+1}$  to  $u_n$  and find the

$$\text{Limit}_{n \rightarrow \infty} \left| \frac{u_{n+1}}{u_n} \right| = \rho.$$

If  $\rho < 1$  in absolute value, the series converges.

If  $\rho > 1$  in absolute value, the series diverges.

If  $\rho = 1$  in absolute value, the ratio test fails and the series must be compared to some series known to be convergent, as

$$a + ar + ar^2 + ar^3 + ar^4 + \dots + ar^{n-1} + \dots \quad r < 1.$$

$$1 + \frac{1}{2^p} + \frac{1}{3^p} + \frac{1}{4^p} + \frac{1}{5^p} + \dots + \frac{1}{n^p} + \dots \quad p > 1.$$

If there is reason to suppose that the series is divergent, compare it with some series known to be divergent, as

$$1 + \frac{1}{2} + \frac{1}{3} + \frac{1}{4} + \frac{1}{5} + \dots + \frac{1}{n} + \dots$$

$$a + ar + ar^2 + ar^3 + \dots + ar^{n-1} + \dots \quad r > 1.$$

$$1 + \frac{1}{2^p} + \frac{1}{3^p} + \frac{1}{4^p} + \frac{1}{5^p} + \dots + \frac{1}{n^p} + \dots \quad p < 1.$$

**455. Series Whose Terms Are Functions of  $x$ .**—Series very often occur in which the terms are functions of some variable  $x$ , and in fact, such series are of great value and importance, as we shall see.

**456. The Power Series.**—The simplest and most important series of this type is the power series represented generally by the expression,

$$a_0 + a_1x + a_2x^2 + a_3x^3 + \dots + a_nx^n + \dots$$

in which the coefficients,  $a_0, a_1, a_2$ , etc., are independent of the value which  $x$  may have. It will be seen later on that these series are of tremendous importance in the calculus. The power series may converge for all values of  $x$  but more often it will converge for some values of  $x$  and diverge for others, and the determination of the values of  $x$  which make the series converge will be the only investigation of the series with which we will be concerned.

If from the above series we form the ratio,

$$\frac{a_{n+1}}{a_n},$$

and observe the behavior of this ratio as  $n$  increases without limit, we are able to determine the interval of convergence, that is, the values of  $x$  for which the series is convergent. If the ratio approaches some definite fixed number as a limit, or in other words, if the relation between the coefficients is such that

$$\text{Limit}_{n \rightarrow \infty} \left( \frac{a_{n+1}}{a_n} \right) = r,$$

then for

$$\left| x \right| < \left| \frac{1}{r} \right|, \text{ the series converges, and for}$$

$$\left| x \right| > \left| \frac{1}{r} \right|, \text{ the series diverges.}$$

If  $r = 0$ , the series converges for all values of  $x$ , and if  $|x| = \left| \frac{1}{r} \right|$ , the test fails. If such a power series is convergent for  $x = b$ , it is convergent for every value of  $x$ , numerically less than  $b$ , that is, for  $-b < x < b$ .

EXAMPLE.

$$\frac{x}{2} + \frac{2^2 x^2}{2^2} + \frac{3^2 x^3}{2^3} + \frac{4^2 x^4}{2^4} + \dots$$

$$a_n = \frac{n^2}{2^n}, \quad a_{n+1} = \frac{(n+1)^2}{2^{n+1}}$$

$$\frac{a_{n+1}}{a_n} = \frac{(n+1)^2}{2n^2}$$

$$\text{Limit}_{n \rightarrow \infty} \left( \frac{a_{n+1}}{a_n} \right) = \text{Limit}_{n \rightarrow \infty} \left( \frac{(n+1)^2}{2n^2} \right) = \text{Limit}_{n \rightarrow \infty} \left( \frac{n^2}{2n^2} + \frac{2n}{2n^2} + \frac{1}{2n^2} \right) = \frac{1}{2}$$

The series is, therefore, convergent for all values of  $x$ , numerically less than 2.

$$|x| < \left( \frac{1}{\frac{1}{2}} \right), \text{ or } x < 2.$$

**457. Binomial Series.**—In Art. 84 *et seq.*, we developed the expansion of the general binomial. If we expand  $(1+x)^n$  according to this method, we get

$$(1+x)^n = 1 + nx + \frac{n(n-1)}{1 \cdot 2} x^2 + \frac{n(n-1)(n-2)}{1 \cdot 2 \cdot 3} x^3 + \frac{n(n-1)(n-2)(n-3)}{1 \cdot 2 \cdot 3 \cdot 4} x^4 + \dots$$

in which  $n$  may be integral, fractional, or negative.

If we have  $(a+x)^n$ , the expansion becomes

$$(a+x)^n = a^n + na^{n-1}x + \frac{n(n-1)}{1 \cdot 2} a^{n-2}x^2 + \frac{n(n-1)(n-2)}{1 \cdot 2 \cdot 3} a^{n-3}x^3 + \frac{n(n-1)(n-2)(n-3)}{1 \cdot 2 \cdot 3 \cdot 4} a^{n-4}x^4 + \dots$$

Any series developed from  $(a+x)^n$  is infinite for fractional or negative values of  $n$  and convergent when  $x$  is numerically less than  $a$ . Values can, therefore, be found to any desired degree of accuracy.

The series is divergent when  $x$  is numerically greater than  $a$ , but in this case the value of  $(a+x)^n$  can be found to any degree of



accuracy by expanding  $(x + a)^n$ , for the latter expansion gives a convergent series.

Consider

$$(1 + x)^m = 1 + mx + \frac{m(m-1)}{2}x^2 + \frac{m(m-1)(m-2)}{3}x^3 + \dots$$

$$a_{n+1} = \frac{m(m-1)(m-2)\dots(m-n)}{n+1}$$

$$a_n = \frac{m(m-1)(m-2)\dots(m-n+1)}{n}$$

$$\frac{a_{n+1}}{a_n} = \frac{m-n}{n+1}$$

$$\lim_{n \rightarrow \infty} \frac{a_{n+1}}{a_n} = \lim_{n \rightarrow \infty} \frac{m-n}{n+1} = \lim_{n \rightarrow \infty} \frac{\frac{m}{n} - 1}{1 + \frac{1}{n}} = -1.$$

The series converges for

$$-1 < x < 1.$$

**458.** In expanding  $(a + x)^n$ , we may write the expression in the form,

$$a^n \left(1 + \frac{x}{a}\right)^n. \quad \text{Art. 123.}$$

Expanding,

$$a^m \left(1 + \frac{x}{a}\right)^m = a^m \left(1 + m\frac{x}{a} + \frac{m(m-1)}{2}\left(\frac{x}{a}\right)^2 + \dots\right)$$

This series converges when

$$\left|\frac{x}{a}\right| < 1, \text{ or}$$

the interval of convergence is the interval from  $-a$  to  $a$ .

**EXAMPLE.**—Expand  $(1 - x)^{-1}$  (see Art. 87).

$$c_1 = \frac{1}{1} = \frac{1}{10} = .1.$$

$$c_2 = c_1 \times \frac{-9}{2} = .1 \times \left(-\frac{9}{20}\right) = -.045.$$

$$c_3 = c_2 \times \frac{-19}{3} = -.045 \times -\frac{19}{30} = .0285.$$

Expanding,

$$(1 - x)^{-1} = 1 - .1x + .045x^2 - .0285x^3 + \dots \text{ etc.}$$

**EXAMPLE.**—Expand  $(1 - 3x)^{-3}$ .

Solving coefficients,

$$c_1 = \frac{-3}{1} = -3.$$

$$c_2 = c_1 \times \frac{-4}{2} = -3 \times -2 = 6.$$

$$c_3 = c_2 \times \frac{-5}{3} = 6 \times \frac{-5}{3} = -10.$$

$$c_4 = c_3 \times \frac{-6}{4} = -10 \times \frac{-3}{2} = 15.$$

Expanding,

$$\begin{aligned} (1 - 3x)^{-3} &= \{1 + (-3x)\}^{-3} = 1 + (-3)(-3x) + 6(-3x)^2 \\ &\quad + (-10)(-3x)^3 + 15(-3x)^4 + \dots \\ &= 1 + 9x - 54x^2 + 270x^3 - 1215x^4 + \dots \end{aligned}$$

**EXAMPLE.**—Expand  $(1 + x)^{-\frac{3}{4}}$  to five terms.

$$c_1 = \frac{-3}{4}.$$

$$c_2 = c_1 \times \frac{-7}{2} = \frac{-3}{4} \times \frac{-7}{8} = \frac{21}{32}.$$

$$c_3 = c_2 \times \frac{-11}{3} = \frac{21}{32} \times \frac{-11}{12} = \frac{-77}{128}.$$

$$c_4 = c_3 \times \frac{-15}{4} = \frac{-77}{128} \times \frac{-15}{16} = \frac{1155}{2048}.$$

Expanding  $(1 + x)^{-\frac{3}{4}} =$

$$1 - \frac{3}{4}x + \frac{21}{32}x^2 - \frac{77}{128}x^3 + \frac{1155}{2048}x^4.$$

Note that the odd powers of  $x$  have negative coefficients.

#### 459. Some Binomial Series.

$$[93] \quad (1 \pm x)^n = 1 \pm nx + \frac{n(n-1)}{1 \cdot 2}x^2 \pm \frac{n(n-1)(n-2)}{1 \cdot 2 \cdot 3}x^3 + \dots$$

Convergent if  $x^2 > 1$ .

$$[94] \quad (1 \pm x)^{-n} = 1 \mp nx + \frac{n(n-1)}{1 \cdot 2}x^2 \mp \frac{n(n-1)(n-2)}{1 \cdot 2 \cdot 3}x^3 + \dots$$

Convergent if  $x^2 < 1$ .

$$[95] \quad (a - bx)^{-1} = \frac{1}{a} \left( 1 + \frac{bx}{a} + \frac{b^2x^2}{a^2} + \frac{b^3x^3}{a^3} + \frac{b^4x^4}{a^4} + \dots \right)$$

Convergent if  $b^2x^2 < a^2$ .

$$[93] \quad (1 \pm x)^{-1} = 1 \mp x + x^2 \mp x^3 + x^4 \mp x^5 + x^6 \mp x^7 + \dots$$

Convergent if  $x^2 < 1$ .

[97]  $(1 \pm x)^{-2} = 1 \mp 2x + 3x^2 \mp 4x^3 + 5x^4 \mp 6x^5 + \dots$

Convergent if  $x^2 < 1$ .

[98]  $(1 \pm x)^{\frac{1}{2}} = 1 \pm \frac{1}{2}x - \frac{1}{2} \cdot \frac{1}{4}x^2 \pm \frac{1}{2} \cdot \frac{3}{4} \cdot \frac{5}{8}x^3 - \frac{1}{2} \cdot \frac{3}{4} \cdot \frac{5}{8} \cdot \frac{7}{16}x^4 \pm \dots$

Convergent if  $x^2 < 1$ .

[99]  $(1 + x)^{-\frac{1}{2}} = 1 \mp \frac{1}{2}x + \frac{1}{2} \cdot \frac{3}{8}x^2 \mp \frac{1}{2} \cdot \frac{3}{4} \cdot \frac{5}{8}x^3 + \frac{1}{2} \cdot \frac{3}{4} \cdot \frac{5}{8} \cdot \frac{7}{16}x^4 \mp \dots$

Convergent if  $x^2 < 1$ .

[100]  $(1 \pm x)^{\frac{3}{2}} = 1 \pm \frac{3}{2}x - \frac{3}{2} \cdot \frac{1}{8}x^2 \pm \frac{3}{2} \cdot \frac{3}{8} \cdot \frac{5}{8}x^3 - \frac{3}{2} \cdot \frac{3}{8} \cdot \frac{5}{8} \cdot \frac{7}{16}x^4 \pm \dots$

Convergent if  $x^2 < 1$ .

[101]  $(1 \pm x)^{-\frac{3}{2}} = 1 \mp \frac{3}{2}x + \frac{3}{2} \cdot \frac{1}{8}x^2 \mp \frac{3}{2} \cdot \frac{3}{8} \cdot \frac{5}{8}x^3 + \frac{3}{2} \cdot \frac{3}{8} \cdot \frac{5}{8} \cdot \frac{7}{16}x^4 \mp \dots$

Convergent if  $x^2 < 1$ .

460. If we put  $\frac{b}{a}$  equal to  $x$  in  $(1 + \frac{b}{a})^n$  (Art. 123) or  $(1 + x)^n$ , and consider the absolute value of  $x$  less than 1, we have

$$(1 + x)^n = 1 + c_1x + c_2x^2 + c_3x^3 + c_4x^4 + \dots$$

Several useful expansions can be made from this form as:

[102]  $\frac{1}{1+x} = (1+x)^{-1} = 1 - x + x^2 - x^3 \dots$

[103]  $\frac{1}{1-x} = (1-x)^{-1} = 1 + x + x^2 + x^3 \dots$

[104]  $\sqrt{(1+x)^3} = (1+x)^{\frac{3}{2}} = 1 + \frac{3x}{2} + \frac{3x^2}{8} - \frac{x^3}{16} \dots$

[105]  $\sqrt{(1-x)^3} = (1-x)^{\frac{3}{2}} = 1 - \frac{3x}{2} + \frac{3x^2}{8} + \frac{x^3}{16} \dots$

[106]  $\frac{1}{\sqrt{(1+x)^3}} = (1+x)^{-\frac{3}{2}} = 1 - \frac{3x}{2} + \frac{15x^2}{8} - \frac{35x^3}{16} \dots$

[107]  $\frac{1}{\sqrt{(1-x)^3}} = (1-x)^{-\frac{3}{2}} = 1 + \frac{3x}{2} + \frac{15x^2}{8} + \frac{35x^3}{16} \dots$

Note that for  $\sqrt{(1-x)}$  the odd powers of  $x$  have the reverse signs from those of  $\sqrt{(1+x)}$ .

**BINOMIAL APPROXIMATIONS**

461. If  $a$  is small compared with 1 and  $n$  is reasonably small, say between the limits of +2 and -2, the terms of the expansion of  $(1 + a)^n$  rapidly become smaller and smaller.

The first approximations are

[108]  $(1 + a)^n \approx 1 + na.$

[109]  $(1 - a)^n \approx 1 - na.$

[110]  $(1 + a)^{-n} \approx 1 - na.$

[111]  $(1 - a)^{-n} \approx 1 + na.$

If a closer approximation is required,

$$[112] \quad (1 + a)^n \approx 1 + na + \frac{n}{2}(n - 1)a^2.$$

$$[113] \quad (1 - a)^n \approx 1 - na + \frac{n}{2}(n - 1)a^2.$$

$$[114] \quad (1 + a)^{-n} \approx 1 - na + \frac{n}{2}(n + 1)a^2.$$

$$[115] \quad (1 - a)^{-n} \approx 1 + na + \frac{n}{2}(n + 1)a^2.$$

The first approximations simply take the first two terms of the binomial expansion, while the second approximations include the third term as well as the first two.

EXAMPLE.—Find the first approximation of  $\sqrt[3]{220}$ .

216 is nearest perfect cube.

$$\begin{aligned} \sqrt[3]{220} &= (216 + 4)^{\frac{1}{3}} = 6(1 + \frac{4}{216})^{\frac{1}{3}} = 6(1 + \frac{1}{54})^{\frac{1}{3}} = \\ &6(1 + na)^{\frac{1}{3}} = 6(1 + \frac{1}{162}) = 6(1 + .00617) = 6.037 \text{ Ans.} \end{aligned}$$

**462. Exponential Series.**—The exponential series is the development, in ascending powers of  $x$ , of the  $x$ th power of a certain constant base. The series is derived from the binomial expansion in the following manner, if  $nx$  is commensurable and  $n$  is numerically greater than 1.

$$\left(1 + \frac{1}{n}\right)^{nx} = 1 + \frac{nx}{n} + \frac{nx(nx-1)}{n^2 \underline{2}} + \frac{nx(nx-1)(nx-2)}{n^3 \underline{3}} + \dots \quad (1)$$

When  $x = 1$ , (1) becomes

$$\left(1 + \frac{1}{n}\right)^n = 1 + 1 + \frac{n(n-1)}{n^2 \underline{2}} + \frac{n(n-1)(n-2)}{n^3 \underline{3}} + \dots \quad (2)$$

$$\left[\left(1 + \frac{1}{n}\right)^n\right]^x = \left(1 + \frac{1}{n}\right)^{nx}, \text{ or}$$

$$\begin{aligned} \left[1 + 1 + \frac{n(n-1)}{n^2 \underline{2}} + \frac{n(n-1)(n-2)}{n^3 \underline{3}} + \dots\right]^x = \\ 1 + x + \frac{nx(nx-1)}{n^2 \underline{2}} + \frac{nx(nx-1)(nx-2)}{n^3 \underline{3}} + \dots \quad (3) \end{aligned}$$

In (3), we may let  $x$  have any finite value while  $n$  increases without limit, numerically. Whatever value  $x$  may have,  $n$  may be so chosen as  $n \rightarrow \infty$  as to make  $nx$  commensurable. Thus,  $nx$  may be made always commensurable.

Accordingly, let  $n$  increase numerically without limit. Then, in (3),

$$\lim_{n \rightarrow \infty} \left[ \frac{n(n-1)}{n^2} \right], \text{ or } \lim_{n \rightarrow \infty} \left[ 1 - \frac{1}{n} \right] = 1.$$

$$\lim_{n \rightarrow \infty} \left[ \frac{n(n-1)(n-2)}{n^3} \right], \text{ or } \lim_{n \rightarrow \infty} \left( 1 - \frac{3n-2}{n^2} \right) = 1.$$

And

$$\lim_{n \rightarrow \infty} \left[ \frac{nx(nx-1)}{n^2} \right], \text{ or } \lim_{n \rightarrow \infty} \left( x^2 - \frac{x}{n} \right) = x^2.$$

$$\lim_{n \rightarrow \infty} \left[ \frac{nx(nx-1)(nx-2)}{n^3} \right], \text{ or } \lim_{n \rightarrow \infty} \left( x^3 - \frac{3nx^2-2x}{n^2} \right) = x^3,$$

and so on.

Hence, for all finite values of  $x$ , (3) becomes

$$\left( 1 + 1 + \frac{1}{2} + \frac{1}{3} + \frac{1}{4} + \dots \right)^x = \tag{4}$$

$$1 + x + \frac{x^2}{2} + \frac{x^3}{3} + \frac{x^4}{4} + \dots$$

$$[116] \quad e^x = 1 + x + \frac{x^2}{2} + \frac{x^3}{3} + \frac{x^4}{4} + \dots$$

In [116], the base  $e$  is a constant equal to (Art. 343) (681)

$$1 + 1 + \frac{1}{2} + \frac{1}{3} + \frac{1}{4} + \dots$$

whose value is 2.7182818+, and the exponent  $x$  is a variable and so may have any finite value. Since in  $e^x$  the variable is an exponent,  $e^x$  is called the exponential function of  $x$ , and the series derived from it is called the exponential series.

**463.** To derive a formula applicable to any positive constant base  $a$ , let

$$\log_e a = k.$$

Then

$$a = e^k.$$

And

$$a^x = e^{kx} = e^{(\log_e a)x}.$$

Therefore, by [116],

$$a^x = 1 + (\log a)x + \frac{(\log a)^2 x^2}{2} + \frac{(\log a)^3 x^3}{3} + \dots$$

where  $\log a = \log_e a$ .

This is the exponential formula or the exponential series when the exponent of  $e$  is  $(\log_e a)x$ , which is convergent for all values of  $x$  not infinite.

Forming the test ratio,  $\frac{a_{n+1}}{a_n}$ , according to Art. 443, we have

$$\frac{(\log a)^{n+1}}{\frac{|n+1|}{n}} = \frac{(\log a)^{n+1}|n|}{(\log a)^n |n+1|} = \frac{\log a}{n+1},$$

and the limit of this expression as  $n$  increases without bound is zero. Therefore, according to Art. 454, the series is convergent for all finite values of  $x$ .

The exponential series is, then,

$$1 + x + \frac{x^2}{2} + \frac{x^3}{3} + \frac{x^4}{4} + \dots + \frac{x^{n-1}}{n-1} + \dots$$

which is convergent for all finite values of  $x$ .

The symyol  $e$  is the base of the natural system of logs.

**464. The Logarithmic Series.**—The logarithmic series is the expansion of  $\log_e (1+x)$  in ascending powers of  $x$ .

$$[117] \quad \log_e (1+x) = x - \frac{x^2}{2} + \frac{x^3}{3} - \frac{x^4}{4} + \dots$$

This series is called the logarithmic series (Art. 980).

In the logarithmic series,

$$a_{n+1} = \pm \frac{1}{n+1}, \quad a_n = \pm \frac{1}{n},$$

$$\text{Limit}_{n \rightarrow \infty} \frac{a_{n+1}}{a_n} = -1.$$

The series is convergent if  $|x| < 1$ .

## CHAPTER XIX

### DETERMINANTS

**465. Expressions of the form,  $a_1b_2 - a_2b_1$ ,** where  $a_1, a_2, b_1,$  and  $b_2$  are any numbers, are found so frequently in mathematics that the relation is expressed as a determinant.

The relation,  $a_1b_2 - a_2b_1$ , expressed in the determinant form is

$$\begin{vmatrix} a_1 & b_1 \\ a_2 & b_2 \end{vmatrix}$$

and is called a *determinant of the second order*.

A determinant of the  $n$ th order is made up of  $n^2$  elements arranged in  $n$  rows and  $n$  columns. The determinant given above is composed of four elements arranged in two rows and two columns.

To evaluate a determinant of the second order, subtract the product of the elements which lie on the principal diagonal from the product of the elements which lie on the secondary diagonal, thus,

$$\begin{vmatrix} a_1 & b_1 \\ a_2 & b_2 \end{vmatrix} = a_1b_2 - a_2b_1.$$

$$\begin{vmatrix} 4 & 7 \\ 3 & -6 \end{vmatrix} = (4)(-6) - (3)(7) = -24 - 21 = -45.$$

Each term of the expansion contains only one element from each row and only one element from each column:

#### **466. Simultaneous Equations in Two Unknowns.**

$$a_1x + b_1y = c_1.$$

$$a_2x + b_2y = c_2.$$

Solving by the usual analytical method of elimination,

$$x = \frac{c_1b_2 - c_2b_1}{a_1b_2 - a_2b_1}, \quad y = \frac{a_1c_2 - a_2c_1}{a_1b_2 - a_2b_1}.$$

Writing both numerators and denominators in determinant form,

$$\frac{\begin{vmatrix} c_1 & b_1 \\ c_2 & b_2 \end{vmatrix}}{\begin{vmatrix} a_1 & b_1 \\ a_2 & b_2 \end{vmatrix}} = x, \quad \frac{\begin{vmatrix} a_1 & c_1 \\ a_2 & c_2 \end{vmatrix}}{\begin{vmatrix} a_1 & b_1 \\ a_2 & b_2 \end{vmatrix}} = y.$$

The determinants which form the denominators are identical and are formed from the coefficients of  $x$  and  $y$  in the original equations.

467. Each determinant in the numerator is formed from the determinant in the denominator by replacing the coefficient of the unknown sought by the constant term. To find the numerator of  $x$ , replace  $a_1$  and  $a_2$ , the coefficients of  $x$ , by  $c_1$  and  $c_2$ , the constant terms. Likewise, replace  $b_1$  and  $b_2$  by  $c_1$  and  $c_2$  to find the value of  $y$ .

EXAMPLE.—Solve, by determinants,

$$\begin{aligned} 2x - y &= 1 \text{ and} \\ 3x + 2y &= 3. \end{aligned}$$

The determinant for the denominator is

$$\begin{vmatrix} 2 & -1 \\ 3 & 2 \end{vmatrix}$$

for both  $x$  and  $y$ .

For the numerator of  $x$ , we replace the  $x$  coefficients by the constants 1 and 3, and we have

$$\begin{vmatrix} 1 & -1 \\ 3 & 2 \end{vmatrix}$$

for the numerator of  $x$ .

Therefore,

$$x = \frac{\begin{vmatrix} 1 & -1 \\ 3 & 2 \end{vmatrix}}{\begin{vmatrix} 2 & -1 \\ 3 & 2 \end{vmatrix}} = \frac{5}{7}.$$

In like manner,

$$y = \frac{\begin{vmatrix} 2 & 1 \\ 3 & 3 \end{vmatrix}}{\begin{vmatrix} 2 & -1 \\ 3 & 2 \end{vmatrix}} = \frac{3}{7}.$$

468. **Determinants of the Third Order.**—The determinant composed of nine elements arranged in three rows and three columns is a determinant of the third order. Thus,

$$\begin{vmatrix} a_1 & b_1 & c_1 \\ a_2 & b_2 & c_2 \\ a_3 & b_3 & c_3 \end{vmatrix}$$



This is merely a convenient symbol for the expression,

$$a_1b_2c_3 + a_2b_3c_1 + a_3b_1c_2 - a_1b_3c_2 - a_2b_1c_3 - a_3b_2c_1.$$

Note that in this development, each term consists of the product of three elements, one and only one from each row, and one and only one from each column.

The developed expression also may be arranged thus,

$$a_1(b_2c_3 - b_3c_2) - a_2(b_1c_3 - b_3c_1) + a_3(b_1c_2 - b_2c_1).$$

The expression in the parentheses are developed determinants of the second order. Therefore, we have

$$\begin{vmatrix} a_1 & b_1 & c_1 \\ a_2 & b_2 & c_2 \\ a_3 & b_3 & c_3 \end{vmatrix} = a_1 \begin{vmatrix} b_2 & c_2 \\ b_3 & c_3 \end{vmatrix} - a_2 \begin{vmatrix} b_1 & c_1 \\ b_3 & c_3 \end{vmatrix} + a_3 \begin{vmatrix} b_1 & c_1 \\ b_2 & c_2 \end{vmatrix}$$

**469.** We now come to a very important method of forming these second-order determinants from the third-order determinant.

Form the product of each element of the first column by the second-order determinants formed by suppressing both the row and the column in which the element is located.

Taking  $a_1$ , suppress the first row and the first column.

$$\begin{vmatrix} \cancel{a_1} & \cancel{b_1} & \cancel{c_1} \\ a_2 & b_2 & c_2 \\ a_3 & b_3 & c_3 \end{vmatrix} = \begin{vmatrix} b_2 & c_2 \\ b_3 & c_3 \end{vmatrix}$$

Taking  $a_2$ , suppress the second row and the first column.

$$\begin{vmatrix} a_1 & b_1 & c_1 \\ \cancel{a_2} & \cancel{b_2} & \cancel{c_2} \\ a_3 & b_3 & c_3 \end{vmatrix} = \begin{vmatrix} b_1 & c_1 \\ b_3 & c_3 \end{vmatrix}$$

Taking  $a_3$ , suppress the third row and the first column.

$$\begin{vmatrix} a_1 & b_1 & c_1 \\ a_2 & b_2 & c_2 \\ \cancel{a_3} & \cancel{b_3} & \cancel{c_3} \end{vmatrix} = \begin{vmatrix} b_1 & c_1 \\ b_2 & c_2 \end{vmatrix}$$

In the development of the third-order determinant, the sign of the second member was changed in order to bring about a development of a second-order determinant. Therefore, the sign of the product which contains the element in the first column and the second row changes.

The determinant of the next lower order which remains when the row and column in which an element stands are suppressed in

a given determinant is called the *minor* of that element. Thus in the determinant,

$$\begin{vmatrix} a_1 & b_1 & c_1 \\ a_2 & b_2 & c_2 \\ a_3 & b_3 & c_3 \end{vmatrix} \text{ the minor of } a_1 \text{ is } \begin{vmatrix} b_2 & c_2 \\ b_3 & c_3 \end{vmatrix}.$$

When the minor is given the proper sign, it is called the *cofactor*.

**470.** The elements of the second or third columns can also be used or the elements of any row, as

$$\begin{vmatrix} a_1 & b_1 & c_1 \\ a_2 & b_2 & c_2 \\ a_3 & b_3 & c_3 \end{vmatrix} = -b_1 \begin{vmatrix} a_2 & c_2 \\ a_3 & c_3 \end{vmatrix} + b_2 \begin{vmatrix} a_1 & c_1 \\ a_3 & c_3 \end{vmatrix} - b_3 \begin{vmatrix} a_1 & c_1 \\ a_2 & c_2 \end{vmatrix}$$

also

$$\begin{vmatrix} a_1 & b_1 & c_1 \\ a_2 & b_2 & c_2 \\ a_3 & b_3 & c_3 \end{vmatrix} = a_1 \begin{vmatrix} b_2 & c_2 \\ b_3 & c_3 \end{vmatrix} - b_1 \begin{vmatrix} a_2 & c_2 \\ a_3 & c_3 \end{vmatrix} + c_1 \begin{vmatrix} a_2 & b_2 \\ a_3 & b_3 \end{vmatrix}$$

**EXAMPLE 1.**—Evaluate

$$\begin{vmatrix} 2 & 3 & 5 \\ 7 & 1 & 4 \\ 6 & 2 & 3 \end{vmatrix} \\ \begin{vmatrix} 2 & 3 & 5 \\ 7 & 1 & 4 \\ 6 & 2 & 3 \end{vmatrix} = 2 \begin{vmatrix} 1 & 4 \\ 2 & 3 \end{vmatrix} - 7 \begin{vmatrix} 3 & 5 \\ 2 & 3 \end{vmatrix} + 6 \begin{vmatrix} 3 & 5 \\ 1 & 4 \end{vmatrix} \\ = 2(3 - 8) - 7(9 - 10) + 6(12 - 5). \\ = -10 + 7 + 42 = 39.$$

**EXAMPLE 2.**—Evaluate

$$\begin{vmatrix} 3 & 2 & 1 \\ 4 & -6 & 2 \\ 1 & 0 & 1 \end{vmatrix} \\ \begin{vmatrix} 3 & 2 & 1 \\ 4 & -6 & 2 \\ 1 & 0 & 1 \end{vmatrix} = 3 \begin{vmatrix} -6 & 2 \\ 0 & 1 \end{vmatrix} - 4 \begin{vmatrix} 2 & 1 \\ 0 & 1 \end{vmatrix} + \begin{vmatrix} 2 & 1 \\ -6 & 2 \end{vmatrix} \\ = 3(-6 - 0) - 4(2 - 0) + (4 + 6). \\ = -18 - 8 + 10 = -16.$$

**471. Solution of Three Simultaneous Equations**

$$a_1x + b_1y + c_1z = d_1.$$

$$a_2x + b_2y + c_2z = d_2.$$

$$a_3x + b_3y + c_3z = d_3.$$

Provided that the determinant formed from the coefficients of the unknowns is not equal to zero, the unknowns may be

expressed as the quotient of two determinants as was done in the case of two equations in two unknowns (Art. 466).

**472.** Any system of three simultaneous equations of the first degree involving three unknowns may be reduced to the general form,

$$a_1x + b_1y + c_1z = d_1, \tag{1}$$

$$a_2x + b_2y + c_2z = d_2. \text{ and} \tag{2}$$

$$a_3x + b_3y + c_3z = d_3. \tag{3}$$

Eliminating one of the unknowns, as  $z$ :

First, between (1) and (2),

$$(a_1c_2 - c_1a_2)x + (b_1c_2 - c_1b_2)y = d_1c_2 - c_1d_2. \tag{4}$$

Second, between (2) and (3),

$$(a_2c_3 - c_2a_3)x + (b_2c_3 - c_2b_3)y = d_2c_3 - c_2d_3. \tag{5}$$

Eliminating  $y$  between (4) and (5),

$$x = \frac{d_1b_2c_3 - d_1c_2b_3 + c_1d_2b_3 - b_1d_2c_3 + b_1c_2d_3 - c_1b_2d_3}{a_1b_2c_3 - a_1c_2b_3 + c_1a_2b_3 - b_1a_2c_3 + b_1c_2a_3 - c_1b_2a_3}$$

$$y = \frac{a_1d_2c_3 - a_1c_2d_3 + c_1a_2d_3 - d_1a_2c_3 + d_1c_2a_3 - c_1d_2a_3}{a_1b_2c_3 - a_1c_2b_3 + c_1a_2b_3 - b_1a_2c_3 + b_1c_2a_3 - c_1b_2a_3}$$

$$z = \frac{a_1b_2d_3 - a_1d_2b_3 + d_1a_2b_3 - b_1a_2d_3 + b_1d_2a_3 - d_1b_2a_3}{a_1b_2c_3 - a_1c_2b_3 + c_1a_2b_3 - b_1a_2c_3 + b_1c_2a_3 - c_1b_2a_3}$$

Note that for three simultaneous equations in three unknowns, the number of terms in the numerators and denominators is 6 or  $\overline{3}$  or  $1 \times 2 \times 3$ .  $x$ ,  $y$ , and  $z$  may be obtained by reducing equations to the general form and substituting.

$$x = \frac{\begin{vmatrix} d_1 & b_1 & c_1 \\ d_2 & b_2 & c_2 \\ d_3 & b_3 & c_3 \end{vmatrix}}{\begin{vmatrix} a_1 & b_1 & c_1 \\ a_2 & b_2 & c_2 \\ a_3 & b_3 & c_3 \end{vmatrix}} \quad y = \frac{\begin{vmatrix} a_1 & d_1 & c_1 \\ a_2 & d_2 & c_2 \\ a_3 & d_3 & c_3 \end{vmatrix}}{\begin{vmatrix} a_1 & b_1 & c_1 \\ a_2 & b_2 & c_2 \\ a_3 & b_3 & c_3 \end{vmatrix}} \quad z = \frac{\begin{vmatrix} a_1 & b_1 & d_1 \\ a_2 & b_2 & d_2 \\ a_3 & b_3 & d_3 \end{vmatrix}}{\begin{vmatrix} a_1 & b_1 & c_1 \\ a_2 & b_2 & c_2 \\ a_3 & b_3 & c_3 \end{vmatrix}}$$

**473.** The denominator in each case is the same determinant which is called the determinant of the system. It is composed of elements which are the coefficients of the unknowns,  $x$ ,  $y$ , and  $z$ .

Each determinant in the numerators is formed by replacing the coefficients of the unknown sought by the constant terms, in the same manner as in the case of the solution of two simultaneous equations.

EXAMPLE.—Solve, by determinants,

$$\begin{aligned}x - 2y + 3z &= 2, \\2x \quad \quad - 3z &= 3, \text{ and} \\x + y + z &= 6.\end{aligned}$$

The determinant of the system is

$$\begin{vmatrix} 1 & -2 & 3 \\ 2 & 0 & -3 \\ 1 & 1 & 1 \end{vmatrix} = 19.$$

Hence,

$$x = \frac{\begin{vmatrix} 2 & -2 & 3 \\ 3 & 0 & -3 \\ 6 & 1 & 1 \end{vmatrix}}{19} \quad y = \frac{\begin{vmatrix} 1 & 2 & 3 \\ 2 & 3 & -3 \\ 1 & 6 & 2 \end{vmatrix}}{19} \quad z = \frac{\begin{vmatrix} 1 & -2 & 2 \\ 2 & 0 & 3 \\ 1 & 1 & 6 \end{vmatrix}}{19}$$

whence  $x = 3, y = 2, z = 1$ .

**474. Cofactor Signs.**—If an element occurs in the  $p$ th row and in the  $m$ th column, its minor multiplied by

$$(-1)^{m+p}$$

is the cofactor with the proper sign.

Take the determinant,

$$\begin{array}{cccc} a_1 & b_1 & c_1 & d_1 \\ a_2 & b_2 & c_2 & d_2 \\ a_3 & b_3 & c_3 & d_3 \\ a_4 & b_4 & c_4 & d_4 \end{array}$$

The cofactor of  $c_3$ , for instance, is

$$\begin{vmatrix} a_1 & b_1 & d_1 \\ a_2 & b_2 & d_2 \\ a_4 & b_4 & d_4 \end{vmatrix} \times (-1)^{3+3} = + \begin{vmatrix} a_1 & b_1 & d_1 \\ a_2 & b_2 & d_2 \\ a_4 & b_4 & d_4 \end{vmatrix}$$

$m = 3$  because  $c_3$  is in the third column.

$p = 3$  because  $c_3$  is in the third row.

If  $m + p$  is odd, the sign is negative.

The cofactors of  $a_1, a_2, a_3$  are usually denoted by  $A_1, A_2, A_3$ , and the determinant by  $D$ .

Therefore,

$$D = a_1A_1 + a_2A_2 + a_3A_3.$$

**475. Determinants of the  $n$ th Order.**—We have so far considered determinants of the second and third order only. In order to solve a system of  $n$  linear equations involving  $n$  unknowns, it is necessary to form the determinant from the  $n^2$

coefficients of the  $n$  unknowns in the  $n$  equations. We then have a determinant of the  $n$ th order that is usually denoted by  $\Delta$ .

$$\Delta = \begin{vmatrix} a_1 & b_1 & \dots & q_1 \\ a_2 & b_2 & \dots & q_2 \\ \dots & \dots & \dots & \dots \\ \dots & \dots & \dots & \dots \\ a_n & b_n & \dots & q_n \end{vmatrix}$$

This determinant will be understood to stand for the algebraic sum of all the different products of  $n$  factors each that can be formed by taking one and only one element from each row and one and only one element from each column, and giving to each a positive or negative sign determined according to the principle of cofactors.

**476. Properties of Determinants.**—The expansion of a determinant of order  $n$  contains  $|n$  terms.

**477. If all elements in a row or column are zero, the determinant equals zero, for expanding in terms of that row or column, each term becomes zero.**

**478. If all elements but one in a row or column are zero, the determinant is equal to the product of that element and its cofactor.**

$$\begin{vmatrix} a_1 & b_1 & c_1 & 0 \\ a_2 & b_2 & c_2 & 0 \\ a_3 & b_3 & c_3 & d_3 \\ a_4 & b_4 & c_4 & 0 \end{vmatrix} = -d_3 \begin{vmatrix} a_1 & b_1 & c_1 \\ a_2 & b_2 & c_2 \\ a_4 & b_4 & c_4 \end{vmatrix}$$

**479. The value of a determinant is not altered when the rows are changed to columns and the columns to rows.**

The proof of this may be made by developing the determinant.

**480. Any theorem which is true for the columns of a determinant is true for its rows, and vice versa.**

**481. The interchange of any two columns (or rows) of a determinant changes the sign of the determinant.**

**482. If two columns (or rows) of a determinant are identical, the determinant is equal to zero.**

**483.** If the elements of any column (or row) be multiplied by the cofactors of the corresponding elements of any other column (or row), the sum of the products equals zero, as

$$b_1A_1 + b_2A_2 + b_3A_3 + \dots + b_kA_k = 0.$$

$$a_2A_1 + b_2B_1 + c_2C_1 + \dots + k_2K_1 = 0.$$

**484.** If all the elements in any column are multiplied by any factor, the determinant is multiplied by that factor, for

$$\begin{vmatrix} ma_1 & b_1 & c_1 & \dots & k_1 \\ ma_2 & b_2 & c_2 & \dots & k_2 \\ ma_3 & b_2 & c_3 & \dots & k_3 \\ \cdot & \cdot & \cdot & \cdot & \cdot \\ \cdot & \cdot & \cdot & \cdot & \cdot \\ \cdot & \cdot & \cdot & \cdot & \cdot \\ ma_n & b_n & c_n & \dots & k_n \end{vmatrix} = ma_1A_1 + ma_2A_2 + ma_3A_3 + \dots + ma_kA_k = m(a_1A_1 + a_2A_2 + a_3A_3 + \dots + a_kA_k) =$$

$$m \begin{vmatrix} a_1 & b_1 & c_1 & \dots & K_1 \\ a_2 & b_2 & c_2 & \dots & K_2 \\ a_3 & b_2 & c_3 & \dots & K_3 \\ \cdot & \cdot & \cdot & \cdot & \cdot \\ \cdot & \cdot & \cdot & \cdot & \cdot \\ \cdot & \cdot & \cdot & \cdot & \cdot \\ a_n & b_n & c_n & \dots & K_n \end{vmatrix}$$

**485.** This principle also is true in the case of division, for a division by  $m$  is equivalent to a multiplication by  $\frac{1}{m}$ .

**486.** If each element in any column (or row) of a determinant is expressed as the sum of two quantities, the determinant can be expressed as the sum of two determinants of the same order.

$$\begin{vmatrix} a_1 + d_1 & b_1 & c_1 & \dots & k_1 \\ a_2 + d_2 & b_2 & c_2 & \dots & k_2 \\ a_3 + d_3 & b_3 & c_3 & \dots & k_3 \\ \cdot & \cdot & \cdot & \cdot & \cdot \\ \cdot & \cdot & \cdot & \cdot & \cdot \\ \cdot & \cdot & \cdot & \cdot & \cdot \\ a_n + d_n & b_n & c_n & \dots & k_n \end{vmatrix} = \begin{vmatrix} a_1 & b_1 & c_1 & \dots & k_1 \\ a_2 & b_2 & c_2 & \dots & k_2 \\ a_3 & b_3 & c_3 & \dots & k_3 \\ \cdot & \cdot & \cdot & \cdot & \cdot \\ \cdot & \cdot & \cdot & \cdot & \cdot \\ \cdot & \cdot & \cdot & \cdot & \cdot \\ a_n & b_n & c_n & \dots & k_n \end{vmatrix} + \begin{vmatrix} d_1 & b_1 & c_1 & \dots & k_1 \\ d_2 & b_2 & c_2 & \dots & k_2 \\ d_3 & b_3 & c_3 & \dots & k_3 \\ \cdot & \cdot & \cdot & \cdot & \cdot \\ \cdot & \cdot & \cdot & \cdot & \cdot \\ \cdot & \cdot & \cdot & \cdot & \cdot \\ d_n & b_n & c_n & \dots & k_n \end{vmatrix}$$

**487.** If each element of a column (or row) is multiplied by the same number, and the products added to (or subtracted from) the corresponding elements of another column (or row), the determinant is not altered in value.

**488. Evaluation of Determinants.**—By means of the principle of Art. 487, all elements but one in a column (or row) can be made equal to zero, and hence (Art. 478), the determinant can

be reduced to one of the next lower order, and this process can be continued until the result is a determinant of the second order.

In many cases, however, the determinant, before reduction, should be simplified by removing factors common to all elements in a row or column and diminishing the absolute values of the elements by subtracting the corresponding elements of other columns (or rows) or multiples of these elements.

EXAMPLES.

Find the value of

$$\Delta = \begin{vmatrix} 2 & -1 & 5 & 1 \\ 1 & 4 & 6 & 3 \\ 4 & 2 & 7 & 4 \\ 3 & 1 & 2 & 5 \end{vmatrix}$$

We will transform this determinant by means of the principle of Art. 487 in such a manner as to make all the elements but one in some row or column equal to zero. The second column offers the best possibilities. We, therefore, add four times the first row to the second row. This replaces the 4 in the second row by 0. We then add two times the first row to the third row, and then add the first row to the fourth row. These operations may be performed without changing the value of the determinant from the rules given in the preceding articles.

The determinant is, then,

$$\Delta = \begin{vmatrix} 2 & -1 & 5 & 1 \\ 9 & 0 & 26 & 7 \\ 8 & 0 & 17 & 6 \\ 5 & 0 & 7 & 6 \end{vmatrix} = \begin{vmatrix} 9 & 26 & 7 \\ 8 & 17 & 6 \\ 5 & 7 & 6 \end{vmatrix}$$

Subtracting the elements of the last column from those of the first column,

$$\Delta = \begin{vmatrix} 2 & 26 & 7 \\ 2 & 17 & 6 \\ -1 & 7 & 6 \end{vmatrix}$$

Add two times the third row to the first row.

Add two times the third row to the second row.

$$\Delta = \begin{vmatrix} 0 & 40 & 19 \\ 0 & 31 & 18 \\ -1 & 7 & 6 \end{vmatrix} = - \begin{vmatrix} 40 & 19 \\ 31 & 18 \end{vmatrix}$$

Subtract the second row from the first row.

$$-\begin{vmatrix} 40 & 19 \\ 31 & 18 \end{vmatrix} = -\begin{vmatrix} 9 & 1 \\ 31 & 18 \end{vmatrix} = -(162 - 31) = -131.$$

**PROBLEM.**—There are three numbers such that the sum of one-half of the first, one-third of the second, and one-fourth of the third is 12; of one-third of the first, one-fourth of the second, and one-fifth of the third is 9, and the sum of the numbers is 38. What are the numbers?

Then

$$\frac{x}{2} + \frac{y}{3} + \frac{z}{4} = 12.$$

$$\frac{x}{3} + \frac{y}{4} + \frac{z}{5} = 9.$$

$$x + y + z = 38.$$

$$x = \frac{\begin{vmatrix} 12 & \frac{1}{2} & \frac{1}{4} \\ 9 & \frac{1}{3} & \frac{1}{5} \\ 38 & 1 & 1 \end{vmatrix}}{\begin{vmatrix} \frac{1}{2} & \frac{1}{3} & \frac{1}{4} \\ \frac{1}{3} & \frac{1}{4} & \frac{1}{5} \\ 1 & 1 & 1 \end{vmatrix}} = \frac{12 \begin{vmatrix} \frac{1}{3} & \frac{1}{5} \\ 1 & 1 \end{vmatrix} - 9 \begin{vmatrix} \frac{1}{2} & \frac{1}{4} \\ 1 & 1 \end{vmatrix} + 38 \begin{vmatrix} \frac{1}{2} & \frac{1}{3} \\ 1 & 1 \end{vmatrix}}{\frac{1}{2} \begin{vmatrix} \frac{1}{3} & \frac{1}{5} \\ 1 & 1 \end{vmatrix} - \frac{1}{3} \begin{vmatrix} \frac{1}{2} & \frac{1}{4} \\ 1 & 1 \end{vmatrix} + \begin{vmatrix} \frac{1}{2} & \frac{1}{3} \\ 1 & 1 \end{vmatrix}}$$

$$= \frac{12(\frac{1}{3} - \frac{1}{5}) - 9(\frac{1}{2} - \frac{1}{4}) + 38(\frac{1}{6} - \frac{1}{6})}{\frac{1}{2}(\frac{1}{3} - \frac{1}{5}) - \frac{1}{3}(\frac{1}{2} - \frac{1}{4}) + (\frac{1}{6} - \frac{1}{6})} = 6.$$

$$y = \frac{\begin{vmatrix} \frac{1}{2} & 12 & \frac{1}{4} \\ \frac{1}{3} & 9 & \frac{1}{5} \\ 1 & 38 & 1 \end{vmatrix}}{\begin{vmatrix} \frac{1}{2} & \frac{1}{3} & \frac{1}{4} \\ \frac{1}{3} & \frac{1}{4} & \frac{1}{5} \\ 1 & 1 & 1 \end{vmatrix}} = \frac{\frac{1}{2} \begin{vmatrix} 9 & \frac{1}{5} \\ 38 & 1 \end{vmatrix} - \frac{1}{3} \begin{vmatrix} 12 & \frac{1}{4} \\ 38 & 1 \end{vmatrix} + \begin{vmatrix} 12 & \frac{1}{4} \\ 9 & \frac{1}{5} \end{vmatrix}}{\text{Same as for } x}$$

$$= \frac{\frac{7}{10} - \frac{5}{6} + \frac{3}{2}}{\frac{1}{6} - \frac{1}{15} + \frac{1}{10}} = 12.$$

From  $x + y + z = 38$ ,  $z = 20$ .

Therefore, the numbers are 6, 12, and 20.

**489. Factoring of a Determinant.**—If a determinant vanishes when any number  $b$  is substituted for another number  $a$ , then  $a - b$  is a factor of the determinant.

**EXAMPLE.**

$$D = \begin{vmatrix} 1 & a & a^2 \\ 1 & b & b^2 \\ 1 & c & c^2 \end{vmatrix}$$

If  $a = b$ , then

$$D = \begin{vmatrix} 1 & b & b^2 \\ 1 & b & b^2 \\ 1 & c & c^2 \end{vmatrix}$$



Since two rows are identical,  $D = 0$ , and  $a - b$  is a factor.

For a similar reason,  $(b - c)$  and  $(c - a)$  are factors.

Since the product of these three factors is of the same degree as  $D$  and can differ from  $D$  only in a numerical factor which we will call  $K$ , therefore,

$$D = K(a - b)(b - c)(c - a).$$

The term obtained from the secondary diagonal of the original determinant is  $bc^2$ , which must be equal to the similar term in

$$K(a - b)(b - c)(c - a),$$

or  $Kbc^2$ .

Hence,

$$bc^2 = Kbc^2 \text{ and } K = 1.$$

Therefore,

$$D = (a - b)(b - c)(c - a).$$

## CHAPTER XX

### PERMUTATIONS AND COMBINATIONS

**490.** If there is one way of doing a first thing and  $r$  ways of doing a second thing, the one way of doing the first thing can be associated with each of the  $r$  ways of doing the second thing.

If there are two ways of doing a first thing and  $r$  ways of doing a second thing, then each of the two ways of doing the first thing can be associated with the  $r$  ways of doing the second thing, or there are  $2r$  ways of doing both.

If there are  $n$  ways of doing one thing, and if, after the first is done, a second thing can be done in  $r$  different ways, then both can be done in succession in  $n \times r$  different ways.

Four men may be eligible for the presidency of a company, and six for the vice-presidency. The number of possible tickets is  $6 \times 4 = 24$ .

If a first thing can be done in  $n$  different ways, and after the first is done, a second can be done in  $r$  different ways, and after the second is done, a third can be done in  $s$  different ways, the three things can be done in  $n \times r \times s$  different ways.

$n$  different articles can be given to  $x$  men and  $a$  women in  $(x + a)^n$  ways. The first article can be given away in  $x + a$  ways. The second article also can be given away in  $x + a$  ways, and likewise, the third, fourth, and fifth articles can each be given in  $x + a$  ways. Therefore, the number of possible ways in which the  $n$  articles can be given to  $x + a$  men and women is

$$(x + a)(x + a)(x + a) \dots \text{to } n \text{ factors, or } (x + a)^n.$$

**491.** Every distinct order in which objects may be placed in a line or row is called a *permutation*, or an *arrangement*.

**492.** Every distinct selection of objects that can be made, irrespective of the order in which they are placed, is called a *combination* or *group*.

Thus the *permutations* of the three letters,  $a, b, c$ , taken two at a time are

$$ab, ac, ba, bc, ca, cb.$$

$ab$  and  $ba$  are different arrangements although they are the same group or *combination*.

If we consider  $a, b$ , and  $c$ , taken all together, we have six arrangements, namely,

$$abc, acb, bca, bac, cab, cba,$$

but only one combination,  $abc$ .

**493.** The number of permutations of  $n$  different things, taken all at a time is the product,

$$n(n-1)(n-2)(n-3) \dots 3 \cdot 2 \cdot 1, \text{ or } \underline{|n|}.$$

Suppose that we have  $n$  different things and we desire to know in how many different ways we may place these  $n$  things in  $n$  different positions. We can put any of the  $n$  things in the first position, and after this is done, any one of the  $(n-1)$  remaining things may be placed in the second position. The first two positions may be occupied in  $n(n-1)$  different ways. Continuing in this manner, there are but two positions left in which to place the next to the last thing, and for the last thing there is but one position available.

**494.** The number of permutations of  $n$  things, taken  $r$  at a time is

$$\frac{|n|}{|n-r|}$$

Suppose that we have  $r$  chairs in a row and we desire to know in how many different ways we may seat  $r$  of  $n$  men in these chairs.

We can place any one of the  $n$  men in the first chair. After the first chair is occupied, we can place any one of the  $(n-1)$  men remaining in the second chair. We, therefore, have  $n(n-1)$  possible arrangements which we can make with the two chairs,  $r \leq n$ .

The last, or  $r$ th, chair can be occupied in as many ways as there are men left. Hence, if we are selecting for the  $r$ th chair, we have already seated  $(r-1)$  men, and since we started with  $n$  men, we will have  $n-(r-1)$  or  $(n-r+1)$  men remaining from which to select for the last chair.

Hence, our total number of ways of seating  $r$  of  $n$  men in  $r$  chairs is

$$n(n-1)(n-2)(n-3) \dots (n-r+1) = \frac{n(n-1)(n-2)(n-3) \dots 3 \cdot 2 \cdot 1}{(n-r)(n-r-1) \dots 3 \cdot 2 \cdot 1} = \frac{|n|}{|n-r|}$$

We call this the number of permutations of  $n$  things taken  $r$  at a time and denote it by the symbol,

$${}_n P_r = \frac{|n|}{|n-r|}$$

**495. The number of combinations, or groups, of  $n$  different things, taken  $r$  at a time is**

$${}_n C_r = \frac{|n|}{|r|(n-r)}$$

In the previous case, there were  $r$  men and there were  $|r|$  permutations of these men, but only one combination. There were, then,  $|r|$  times as many permutations as there were combinations.

If  $x$  is the number of combinations, then  $x \times |r|$  equals the number of permutations, or

$$x \times |r| = \frac{|n|}{|(n-r)|}, \text{ or } x = \frac{|n|}{|r|(n-r)}$$

CHAPTER XXI  
UNDETERMINED COEFFICIENTS

PARTIAL FRACTIONS

**496. Undetermined Coefficients.**—Coefficients assumed in demonstrating a principle or solution of a problem whose values, not known at the outset, are to be determined by subsequent processes, are called *undetermined coefficients*.

To expand  $(x - 1)(x + 1)(x - 2)$  without actual multiplication, put

$$(x - 1)(x + 1)(x - 2) = x^3 + Ax^2 + Bx + C. \quad (1)$$

To determine the values of  $A$ ,  $B$ , and  $C$  from the identity which must be true for all values of  $x$ , let  $x = 0$  in (1).

Then if  $x = 0$ ,  $C = 2$ .

If  $x = 1$ , equation (1) becomes

$$0 = 1 + A + B + C.$$

If  $x = -1$ , equation (1) becomes

$$0 = -1 + A - B + C.$$

By solving these three conditional equations,

$$A = -2, \quad B = -1, \quad C = 2.$$

Therefore,

$$(x - 1)(x + 1)(x - 2) = x^3 - 2x^2 - x + 2.$$

**497. Development of Fractions.**

EXAMPLE.—Develop

$$\frac{1 + 2x}{1 + x + x^2}.$$

The first term of the development by ordinary division is evidently  $1 \div 1$ , or 1, and since the denominator is not exactly contained in the numerator, the development is an infinite series beginning with 1 and proceeding according to ascending powers of  $x$ .

To determine the coefficients of the various powers, assume

$$\frac{1 + 2x}{1 + x + x^2} = 1 + Ax + Bx^2 + Cx^3 + Dx^4 + \dots \quad (1)$$

true for all values of  $x$  that make the second member a convergent series.

Multiply the series by the denominator and simplify; then,

$$\begin{aligned} 1 + 2x &= 1 + A|x + B|x^2 + C|x^3 + D|x^4 + \dots \\ &+ 1| + A| + B| + C| + \dots \\ &+ 1| + A| + B| + \dots \end{aligned} \quad (2)$$

Using the principle of undetermined coefficients (Art. 496), we can equate the coefficients in the two series and expand. The left-hand member can be regarded as an infinite series,

$$1 + 2x + 0x^2 + 0x^3 + 0x^4 + \dots$$

This series has a definite sum for every value of  $x$ , while the second member is an infinite series having a definite sum for such values of  $x$  as make the series assumed in (1) convergent.

Therefore, since (2) is true for all values of  $x$  that make the assumed series convergent, by the principle of undetermined coefficients (Art. 496), the coefficients of like powers of  $x$  in (2) may be equated.

Hence,

$$A + 1 = 2. \quad \therefore A = 1.$$

$$B + A + 1 = 0. \quad \therefore B = -2.$$

$$C + B + A = 0. \quad \therefore C = +1.$$

$$D + C + B = 0. \quad \therefore D = +1.$$

$$\therefore \frac{1 + 2x}{1 + x + x^2} = 1 + x - 2x^2 + x^3 + x^4 + \dots$$

The fraction may be developed also by division.

EXAMPLE.—Develop

$$\frac{2 - x + 2x^2}{x^2 - 2x^3}.$$

Since the first term of the quotient is evidently  $\frac{2}{x^2}$ , or  $2x^{-2}$ , assume

$$\frac{2 - x + 2x^2}{x^2 - 2x^3} = Ax^{-2} + Bx^{-1} + C + Dx + Ex^2 + \dots$$

Clearing of fractions and multiplying both sides by  $x^2$ , there results

$$\begin{aligned} 2 - x + 2x^2 &= A + B|x + C|x^2 + D|x^3 + E|x^4 + \dots \\ &-2A| -2B| -2C| -2D| \end{aligned}$$

Equating the coefficients of like powers of  $x$  and solving,

$$A = 2, B = 3, C = 8, D = 16, E = 32.$$

$$\therefore \frac{2-x+2x^2}{x^2-2x^3} = 2x^{-2} + 3x^{-1} + 8 + 16x + 32x^2 + \dots$$

**498. Development of Surds.**—To develop the expression,

$$\sqrt{a+x},$$

by the use of undetermined coefficients, assume

$$\sqrt{a+x} = A + Bx + Cx^2 + Dx^3 + Ex^4 + \dots$$

Squaring,

$$a+x = A^2 + 2ABx + B^2x^2 + 2ADx^3 + C^2x^4 + 2ACx^2 + 2BCx^3 + 2AEx^2 + 2BDx^3$$

Equating the coefficients of like powers,

$$A^2 = a. \quad \therefore A = \sqrt{a}.$$

$$2AB = 1. \quad \therefore B = \frac{1}{2A} = \frac{\sqrt{a}}{2a}.$$

$$B^2 \text{ when the den. } \therefore C = -\frac{\sqrt{a}}{8a^2}.$$

, some of which

$$2AD = 0. \quad \therefore D = \frac{\sqrt{a}}{16a^3}.$$

$$C^2 + 2AE + 2BD = 0. \quad \therefore E = -\frac{5\sqrt{a}}{128a^4}.$$

$$\therefore \sqrt{a+x} = \sqrt{a} \left( 1 + \frac{x}{2a} - \frac{x^2}{8a^2} + \frac{x^3}{16a^3} - \frac{5x^4}{128a^4} + \dots \right).$$

The given surd may also be developed by the extraction of the roots indicated or by the binomial formula. But whatever method is used for the development, the series obtained is equal to the surd only for such values of  $x$  as make the series convergent.

**499. Partial Fractions.**—The addition of fractions results in a single fraction whose denominator is the lowest common multiple of the denominators. Thus,

$$\frac{5}{2(x-1)} + \frac{7}{2(x-3)} - \frac{6}{x-2} = \frac{x+4}{4(x^3-6x^2+11x-6)}.$$

It is often desirable to perform the reverse operation, that is, break up a given fraction into the sum or difference of fractions

having denominators lower in degree and more convenient to handle.

Proper fractions, or fractions having the numerator of lower degree than the denominator, are the only fractions that will be considered since, if the numerator is of higher degree than the denominator, it may be divided by the denominator, giving a polynomial and a proper fraction.

The number of partial fractions that may represent a given fraction depends upon the number of prime factors into which the denominator may be separated.

The important thing to remember is that the numerator of any partial fraction taken should always be of degree one less than the degree of the denominator.

There are four classes of partial fractions.

**500. Case 1.**—When the denominator can be resolved into first-degree or linear factors, all of which are real and different. Consider the fraction,

$$\frac{x + 4}{(x - 1)(x - 2)(x - 3)}$$

and develop the partial fractions

Let

$$\frac{x + 4}{(x - 1)(x - 2)(x - 3)} = \frac{A}{x - 1} + \frac{B}{x - 2} + \frac{C}{x - 3}$$

Simplify by multiplying by  $(x - 1)(x - 2)(x - 3)$ .

$$x + 4 = A(x - 2)(x - 3) + B(x - 1)(x - 3) + C(x - 1)(x - 2) = (A + B + C)x^2 - (5A + 4B + 3C)x + 6A + 3B + 2C$$

Equating the coefficients of like powers after making two series,  
 $0x^2 + x + 4 = (A + B + C)x^2 - (5A + 4B + 3C)x + 6A + 3B + 2C$ .

Then

$$\begin{aligned} 0 &= A + B + C. \\ -1 &= 5A + 4B + 3C. \\ 4 &= 6A + 3B + 2C. \end{aligned}$$

Solving simultaneously,

$$A = \frac{5}{2}, \quad B = -6, \quad C = \frac{7}{2}.$$

Forming equation,

$$\frac{x + 4}{(x - 1)(x - 2)(x - 3)} = \frac{5}{2(x - 1)} - \frac{6}{x - 2} + \frac{7}{2(x - 3)}$$



Another method is to consider the separate factors of the denominator, as  $x - 1$ ,  $x - 2$ ,  $x - 3$ , by Art. 499, and substitute the roots, as 1, 2, 3, for  $x$ , since the remainder is zero in each case.

After simplifying,

$$x + 4 = A(x - 2)(x - 3) + B(x - 1)(x - 3) + C(x - 1)(x - 2).$$

Substituting  $x = 1$ ,

$$5 = 2A + 0 + 0.$$

$$A = \frac{5}{2}, \text{ as before.}$$

Substituting  $x = 2$ ,

$$6 = 0 - B + 0.$$

$$B = -6, \text{ as before.}$$

Substituting  $x = 3$ ,

$$7 = 0 + 0 + 2C.$$

$$C = \frac{7}{2}, \text{ as before.}$$

The rule, then, for factor  $x - a$  is to assume the partial fraction,

$$\frac{A}{x - a}.$$

**501. Case 2.**—When the denominator can be resolved into real linear factors, some of which are repeated, as

$$\frac{5x^2 - 6x - 5}{(x - 1)^3(x + 2)}.$$

In this case, we use the factor  $(x - 1)^3$ , but we use also the factors  $(x - 1)^2$  and  $(x - 1)$ , for they may enter into the fraction. In the event that they do not form a part of the fraction, the numerator will be zero. Then

$$\frac{5x^2 - 6x - 5}{(x - 1)^3(x + 2)} = \frac{A}{x - 1} + \frac{B}{(x - 1)^2} + \frac{C}{(x - 1)^3} + \frac{D}{x + 2}.$$

Simplifying by multiplying by  $(x - 1)^3(x + 2)$ ,

$$5x^2 - 6x - 5 = A(x - 1)^2(x + 2) + B(x - 1)(x + 2) + C(x + 2) + D(x - 1)^3.$$

Let  $x = -2$ ; we find  $D = -1$ . Let  $x = 1$ ; we find  $C = -2$ .

From these,  $A = 1$ ,  $B = 2$ .

Hence,

$$\frac{5x^2 - 6x - 5}{(x - 1)^3(x + 2)} = \frac{1}{x - 1} + \frac{2}{(x - 1)^2} - \frac{2}{(x - 1)^3} - \frac{1}{x + 2}.$$

The first method of Art. 500 may also be used.

**RULE.**—When the factor  $(x - a)^n$  appears in the denominator, assume the sum of the partial factors,

$$\frac{A}{x - a} + \frac{B}{(x - a)^2} + \dots + \frac{N}{(x - a)^n}.$$

**502. Case 3.**—When the denominator contains quadratic factors which are not repeated and which cannot be separated into linear factors, thus,

$$\frac{3x^2 - 2}{(x^2 + x + 1)(x + 1)}.$$

Assume

$$\frac{3x^2 - 2}{(x^2 + x + 1)(x + 1)} = \frac{Ax + B}{x^2 + x + 1} + \frac{C}{x + 1}.$$

Simplifying,

$$3x^2 - 2 = (Ax + B)(x + 1) + C(x^2 + x + 1) = (A + C)x^2 + (A + B + C)x + B + C.$$

Using the method of Art. 500, or equating the coefficients of like powers,

$$\begin{aligned} A + C &= 3, & A &= 2. \\ A + B + C &= 0, & \text{whence } B &= -3. \\ B + C &= -2, & C &= 1. \end{aligned}$$

And

$$\frac{3x^2 - 2}{(x^2 + x + 1)(x + 1)} = \frac{2x - 3}{x^2 + x + 1} + \frac{1}{x + 1}.$$

The numerator of the quadratic factor is taken as  $Ax + B$  because a quadratic has two roots.

**RULE.**—When one of the factors of the denominator is a prime quadratic, assume the partial fraction,

$$\frac{Ax + B}{ax^2 + bx + c}.$$

**503. Case 4.**—When the denominator contains quadratic factors that are repeated, as

$$\frac{x^4 + x^3 - 2x^2 - 5x - 4}{(x - 1)(x^2 + x + 1)^2},$$

equate the fraction to

$$\frac{A}{x - 1} + \frac{Bx + C}{x^2 + x + 1} + \frac{Dx + E}{(x^2 + x + 1)^2}.$$

From this equality, the solution is obtained in the same manner as in the previous cases.

**RULE.**—When the factor,  $(ax^2 + bx + c)^n$ , appears in the denominator, assume the sum of the partial factors,

$$\frac{Ax + B}{ax^2 + bx + c} + \frac{Cx + D}{(ax^2 + bx + c)^2} + \dots + \frac{Mx + N}{(ax^2 + bx + c)^n}.$$

In all cases, the numerator of any partial fraction must be of degree one less than the degree of the factor which occurs in that denominator.

CHAPTER XXII  
GEOMETRY AND MENSURATION

ANGLES

504. Two angles are *complementary*, or complements, when their sum is equal to a right angle.

505. Two angles are *supplementary*, or supplements, when their sum is equal to two right angles ( $180^\circ$ ), or a straight angle.

506. Two angles, which have the sides of one perpendicular to the sides of the other, are either equal or supplementary.

507. Two angles whose sides are parallel, each to each, are either equal or supplementary.

508. **Right Triangles.**—If  $a$  and  $b$  are the lengths of the legs and  $c$  the length of the hypotenuse,

[118]  $a^2 + b^2 = c^2.$

[119]  $a = \sqrt{(c + b)(c - b)},$  or

[120]  $a = c \sin A = b \tan A,$  or

[121]  $a = \sqrt{mc}.$

[122]  $b = \sqrt{(c + a)(c - a)},$  or

[123]  $b = c \cos A = \frac{a}{\tan A},$  or

[124]  $b = \sqrt{nc}.$

[125]  $c = \sqrt{a^2 + b^2},$  or

[126]  $c = \frac{a}{\sin A} = \frac{b}{\cos A},$  or

[127]  $c = m + n.$

[128] Area =  $\frac{1}{2}ab$

[129] =  $\frac{1}{2}a^2 \cot A = \frac{1}{2}b^2 \tan A$

[130] =  $\frac{1}{4}c^2 \sin 2A$

[131] =  $\frac{1}{2}bc \sin A$

[132] =  $\frac{1}{2}ac \sin B$

[133] =  $\frac{a^3}{2 \tan A}$

[134]  $p^2 = mn.$

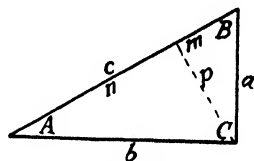

FIG. 160.

**509.** In a right triangle whose acute angles are  $30^\circ$  and  $60^\circ$ , the hypotenuse is twice as long as the short side, and the long side is  $\sqrt{3}$  times the short side.

**510.** If a triangle is inscribed in a semicircle, it is a right triangle.



FIG. 161.

**511. Theorem of Pythagoras.**—The square on the hypotenuse of a right triangle is equal to the sum of the squares on the other two sides.

$$c^2 = a^2 + b^2.$$

The square on the side  $a$  is also equal to the rectangle of dimensions  $m$  and  $c$ , and the square on the side  $b$  is equal to the rectangle of dimensions  $n$  and  $c$ .

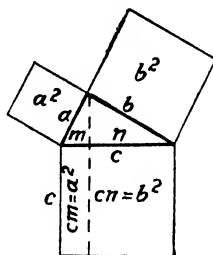

FIG. 162.

**512.** In a right triangle, the perpendicular from the vertex to the hypotenuse is the mean proportional between the segments of the hypotenuse, or

[135] 
$$\frac{m}{p} = \frac{p}{n}, \text{ or } p = \sqrt{mn}.$$

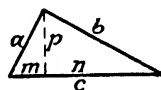

FIG. 163.

**513.** In a right triangle, either side is a mean proportional between its projection on the hypotenuse and the entire hypotenuse, as

$$\frac{m}{a} = \frac{a}{c}, \text{ or } \frac{n}{b} = \frac{b}{c}, \text{ or } a = \sqrt{mc} \text{ [121], and } b = \sqrt{nc} \text{ [124].}$$

These are geometric statements corresponding to [118], [121], [124], and [134].

**514. Equilateral Triangle.**

[136] 
$$A = B = C = 60^\circ.$$

[137] 
$$\text{Area} = \frac{1}{2}ah$$

[138] 
$$= \frac{1}{2}a^2\sqrt{3} = 0.43301a^2.$$

[139] 
$$h = \frac{1}{2}a\sqrt{3} = 0.866a.$$

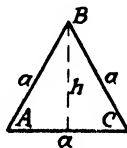

FIG. 164.

**515. Any Plane Triangle.**

[140] 
$$A + B + C = 180^\circ = \pi \text{ radians, or } 180^\circ - A = B + C.$$

That is, an exterior angle is equal to the sum of the two opposite interior angles.

Considering  $s$  as equal to one-half the sum of the sides, or

$$[141] \quad s = \frac{1}{2}(a + b + c),$$

the radius  $r$  of the inscribed circle is given by

$$[142] \quad r = \sqrt{\frac{(s-a)(s-b)(s-c)}{s}}.$$

The radius  $R$  of the circumscribed circle is equal to

$$[143] \quad R = \frac{a}{2 \sin A} = \frac{b}{2 \sin B} = \frac{c}{2 \sin C}.$$

$$[144] \quad \text{Area of triangle} = \frac{1}{2}bh = \sqrt{s(s-a)(s-b)(s-c)}.$$

**516.** The medians are lines joining the vertices with the centers of the opposite sides and intersect at the center of gravity  $G$ . The point  $G$  is one-third the altitude above the base.



FIG. 166.

**517.** Lines drawn from the vertices perpendicular to the opposite sides intersect at a point  $O$  called the orthocenter.



FIG. 167.

**518.** Lines drawn perpendicular to the sides at their centers intersect at a point  $C$ , which is the center of the circumscribed circle.

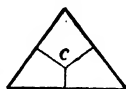

FIG. 168.

$G$ ,  $O$ , and  $C$  lie on a straight line with  $G$  two-thirds the distance from  $O$  to  $C$ .

**519.** Lines bisecting the angles meet at a point  $H$ , which is the center of the inscribed circle.



FIG. 169.

**520. Ratios.**—A line, as  $MN$ , parallel to one side ( $AC$ ) of a triangle, divides the other two sides into segments having equal ratios, thus,

$$\frac{AM}{MB} = \frac{CN}{NB}.$$

A line, as  $AM$ , bisecting an angle of a triangle, divides the side opposite that angle into segments whose ratio is equal to the ratio of the other two sides.

$$\frac{BM}{MC} = \frac{AB}{AC}.$$

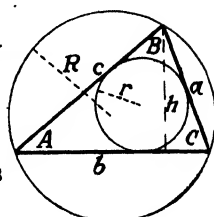

FIG. 165.

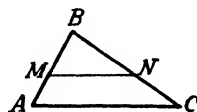

FIG. 170.

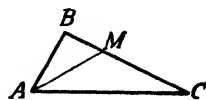

FIG. 171.

**521. Congruent Triangles.**—Two triangles are congruent if two sides and the included angle of one are equal, respectively, to the corresponding two sides and the included angle of the other.



FIG. 172.

**522.** Two triangles are congruent if two angles and the side included between their vertices of one triangle are equal, respectively, to the corresponding two angles and the included side of the other.

**523.** If three sides of one triangle are equal, respectively, to the three sides of another triangle, the triangles are congruent.

**524. Similar Triangles.**—Two triangles are similar if the angles of one are equal to the angles of the other, and their corresponding sides are proportional.

**525.** A line parallel to one side of a triangle forms with the other two sides a triangle *similar* to the given triangle.

$\triangle DCE$  is similar to  $\triangle ACB$  when  $DE$  is parallel to  $AB$ .

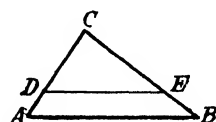

FIG. 173.

**526.** Two triangles are similar if two angles of one are equal, respectively, to the corresponding angles of the other; thus, if  $A$  and  $A'$  are equal and  $C$  and  $C'$  are equal, the triangles,  $ABC$  and  $A'B'C'$ , are similar.

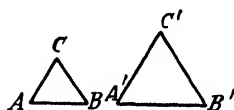

FIG. 174.

**527. Graphical Multiplication and Division by Similar Triangles.**

Multiply, graphically,

$$a \times b.$$

**RULE.**—Draw, preferably, a right triangle whose base is equal to one of the numbers and whose altitude equals 1. From this

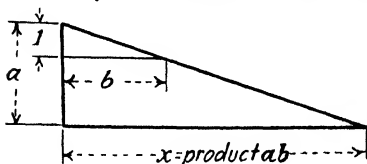

FIG. 175.

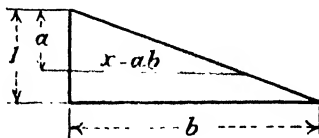

FIG. 176.

triangle, draw a second similar triangle by extending the sides. Make the other number the altitude of this second triangle. The base of the second triangle is the required product.

PROOF.—Since the triangles formed are similar, then

$$x : a :: b : 1,$$

or

$$x = ab.$$

In the case where  $a < 1$ , our triangles would take a form similar to that shown in Fig. 176.

In the case where  $a < 1$  and  $b < 1$ , our triangles would be as shown in Fig. 177.

Divide, graphically,  $\frac{a}{b}$ .

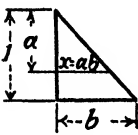

FIG. 177.

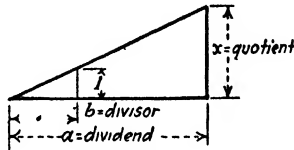

FIG. 178.

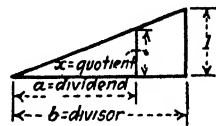

FIG. 179.

RULE.—Draw a right triangle with base equal to the divisor and altitude equal to 1. Draw a similar triangle by extending the sides and make the base of the second triangle equal to the dividend. The altitude of this triangle is the quotient.

Caution.—Be sure to form the first triangle with the divisor and 1 as the sides.

PROOF.— $x : a :: 1 : b$ .

Therefore,

$$x = \frac{a}{b}.$$

In the case where the dividend is smaller than the divisor, our triangles would resemble those shown in Fig. 179.

### 528. Rectangle.

[145] Area =  $ab$

[146] =  $\frac{1}{2} d^2 \sin U$ .

[147]  $d = \text{diagonal} = \sqrt{a^2 + b^2}$ .

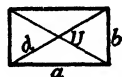

FIG. 180.

[148]  $U = \text{acute angle between diagonals} = 2 \tan^{-1} \frac{b}{a}$ .

### 529. Parallelogram.

[149] Area =  $bh$

[150] =  $ab \sin C$ .

The opposite sides are parallel.

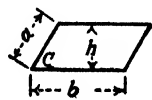

FIG. 181.



A diagonal divides it into congruent triangles.

The opposite sides are equal.

The consecutive angles are supplementary.

The diagonals bisect each other.

[151]  $\text{Area} = \frac{d_1 \times d_2}{2} \sin U$ , where  $d_1$  and  $d_2$  are the diagonals and  $U$  is the angle between them (less than  $90^\circ$ ).

The center of gravity is at the intersection of the diagonals.

**530. Rhombus.**

A quadrilateral having oblique angles but equal sides is a rhombus.

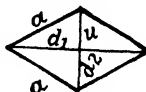

FIG. 182.

[152]  $\text{Area} = a^2 \sin C$ ,

where  $C$  is the angle between adjacent sides.

[153] Area also equals  $\frac{d_1 \times d_2}{2}$ , where  $d_1$  and  $d_2$  are diagonals.

**531. Trapezoid.**

A quadrilateral with one pair of opposite sides parallel is a trapezoid.

[154]  $\text{Area} = \frac{(a + b)h}{2}$

[155]  $= \frac{d_1 \times d_2}{2} \sin U$ .

[156]  $(d_1)^2 + (d_2)^2 = r^2 + S^2 + 2ab$ .

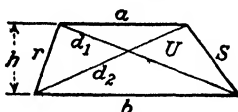

FIG. 183.

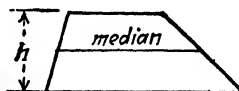

FIG. 184.

A line drawn through the midpoints of the non-parallel sides is the median of the trapezoid.

The length of the median is equal to one-half the sum of the bases.

The area is equal to the product of the median and the altitude  $h$ .

To find the center of gravity of the trapezoid, divide the trapezoid into triangles and find the centers of gravity of these triangles. The line joining the centers of the parallel sides and the line joining the centers of gravity of the triangles intersect at the center of gravity of the trapezoid.

**532. Quadrilateral.**

Any figure of four sides is a quadrilateral.

$$[157] \quad \text{Area} = \frac{d_1 \times d_2}{2} \sin U.$$

$$[158] \quad a^2 + b^2 + c^2 + d^2 = (d_1)^2 + (d_2)^2 + 4m^2,$$

where  $m$  is the distance between the midpoints of  $d_1$  and  $d_2$ .

The most common method of finding the area is to divide the quadrilateral into two triangles and find the sum of the areas of these triangles.

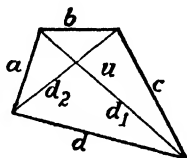

FIG. 185.



FIG. 186.

The sum of the interior angles is  $360^\circ$ .

$$[159] \quad \text{Area} = \frac{lh}{2}, \text{ where } l = \text{length of diagonal and } h = \text{the altitude perpendicular to the diagonal (Fig. 186).}$$

**533. Regular Polygons.**—In a regular polygon, all sides are equal and all angles are equal.

If  $n$  = the number of sides,

$$[160] \quad \angle A = \frac{n-2}{n} \cdot 180^\circ = \frac{n-2}{n} \cdot \pi,$$

if  $A$  is expressed in radians.

$$[161] \quad \angle B = \frac{360^\circ}{n} = \frac{2\pi}{n} \text{ radians.}$$



FIG. 187.

$n$	$\frac{a}{R}$	$\frac{r}{a}$	$\frac{R}{a}$	AREA
3	1.732	.2887	.5773	.433 $a^2$
4	1.414	.5	.7071	1.0000 $a^2$
5	1.1756	.6882	.8506	1.7205 $a^2$
6	1.0000	.866	1.0000	2.5981 $a^2$
7	.8677	1.0383	1.1524	3.6339 $a^2$
8	.7653	1.2071	1.3066	4.8284 $a^2$
$n$	$2R \sin \frac{R}{2}$	$\frac{a}{2} \cot \frac{R}{2}$	$\frac{a}{2} \csc \frac{R}{2}$	$\frac{na^2}{4} \cot \frac{R}{2}$

**534. Construction of Regular Polygons.**—Any regular polygon may be constructed as follows:

Consider a polygon of seven sides or a heptagon. Draw a semi-circle  $HGB$  with radius  $AB$  equal to the side of the heptagon.

Divide the semicircumference into seven parts and draw radii through the points of division extending them beyond the circumference. Set the divider on  $G$  and with radius equal to side, locate points  $F, E, D,$  and  $C$ . Join these points and the heptagon is completed.

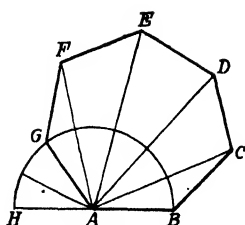

FIG. 188.

**535. Similar Polygons.**—Two polygons are similar if the ratios of the corresponding sides are equal and the corresponding angles are equal.

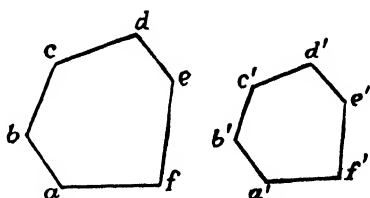

FIG. 189.

**536. To construct similar polygons** with sides having ratios  $\frac{B'A}{BA}$ .

From the point  $A$  draw diagonals extended as shown. From  $B'$  draw  $B'C'$  parallel to  $BC$ . Continue around the polygon in the same manner, drawing all corresponding sides parallel.

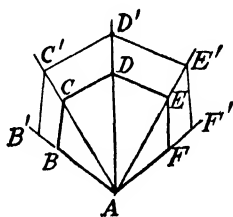

FIG. 190.

$A'B'C'D'E'F'$  is then similar to  $ABCDEF$ .

Similar polygons may be divided by diagonals into triangles similar to each other and similarly placed.

**537. Circle.**

[162] Circumference = Diameter  $\times$  3.1416 = Radius  $\times$  6.2832.

$$[163] \text{ Area} = \pi \times (\text{Radius})^2 = \frac{\text{Circumference} \times \text{Radius}}{2} =$$

$$\frac{\text{Circumference} \times \text{Diameter}}{4} = \frac{1}{4}\pi \times (\text{Diameter})^2 =$$

$$.7854(\text{Diameter})^2.$$

$A$  = angle in radians.

[164]  $S = rA = 2r \cos^{-1} \frac{d}{r} = 2r \tan^{-1} \frac{c}{2d}.$

[165]  $c = 2\sqrt{r^2 - d^2} = 2r \sin \frac{A}{2} = 2d \tan \frac{A}{2} = 2d \tan \frac{S}{2r}.$

$$[166] \quad d = \frac{\sqrt{4r^2 - c^2}}{2} = \frac{\sqrt{D^2 - c^2}}{2} = r \cos \frac{A}{2} = \frac{c}{2} \cot \frac{A}{2} = \frac{c}{2} \cot \frac{S}{D}.$$

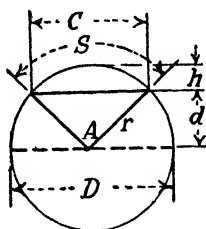

FIG. 191.

$$[167] \quad A \text{ (in radians)} = \frac{S}{r} = 2 \cos^{-1} \frac{d}{r} = 2 \tan^{-1} \frac{c}{2d} = 2 \sin^{-1} \frac{C}{D}.$$

538. An inscribed angle, as  $A$ , is measured by one-half the arc intercepted by its sides, or angle  $A$  is one-half of  $B$ .

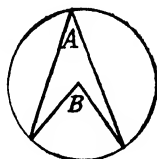

FIG. 192.

539. All inscribed angles subtended by the same arc are equal.

$$\angle A = \angle B = \angle C.$$

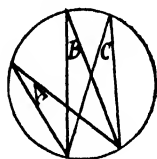

FIG. 193.

540. If an inscribed angle is subtended by one-half the circumference, the angle is  $90^\circ$ , or  $\frac{\pi}{2}$  radians.

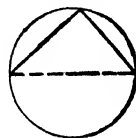

FIG. 194.

541. If the subtended arc is less than one-half the circumference, the angle is acute.

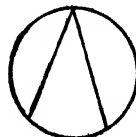

FIG. 195.

542. If the subtended arc is greater than one-half the circumference, the angle is obtuse.



FIG. 196.

543. The angle  $B$  between the chord  $cd$  and the tangent  $cb$  is measured by one-half the arc  $dac$ , or it is equal to one-half the angle  $A$ .

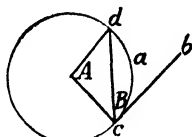

FIG. 197.

544. The angle between a tangent  $cb$  and a chord  $cd$  drawn from the point of tangency is equal to any inscribed angle, as  $B$  or  $C$ , subtending the same chord  $cd$ .

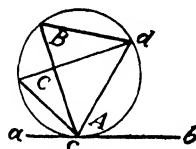

FIG. 198.

545. If two chords intersect within a circle, either angle formed is measured by one-half the sum of the intercepted arcs.

$$\angle A = \frac{1}{2}(\text{arc } ac + \text{arc } db).$$

$$\angle B = \frac{1}{2}(\text{arc } ad + \text{arc } cb).$$

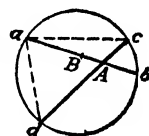

FIG. 199.

546. If two secants, as  $ab$  and  $cb$ , meet outside a circle, the angle formed is measured by one-half the difference of the intercepted arcs. Also,

$$\angle A = (\angle B - \angle C).$$

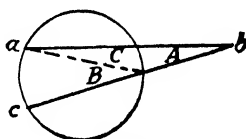

FIG. 200.

547. The angle formed by a tangent and a secant meeting outside of a circle is measured by one-half the difference of the intercepted arcs. Also,

[168]  $\angle A$  is measured by one-half arc  $s$  - one-half arc  $n$ , or

$$\angle A = (\angle D - \angle C).$$

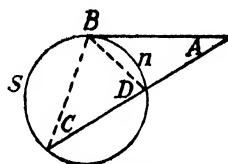

FIG. 201.

548. The angle formed by two tangents to a circle is equal to one-half the difference of the intercepted arcs.

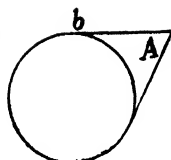

FIG. 202.

549. If two chords of a circle intersect, the product of the segments of one is equal to the product of the segments of the other.

[169]  $AD \times DC = ED \times DB.$

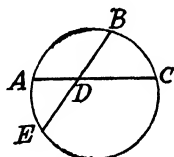

FIG. 203.

550. If a variable line through A cuts a circle at P and Q, then

[170]  $AP \times AQ$  is constant.

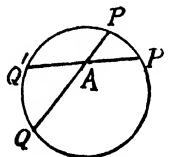

FIG. 204.

551. If a variable line through A, located outside the circle, cuts the circle at P and Q, then

[171]  $AP \times AQ = \overline{AT}^2,$

where AT is the tangent from A.

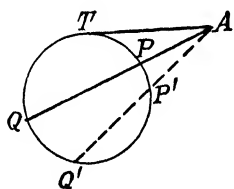

FIG. 205.

552. If from a point A without a circle a tangent and a secant be drawn, the tangent AD is a mean proportional between the entire secant AC and its external segment.

[172]  $\frac{AC}{AD} = \frac{AD}{AB}.$

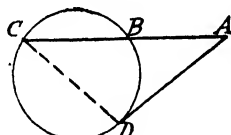

FIG. 206.

553. If from a point as C without a circle two secants are drawn to the concave arc, the product of one secant and its external segment is equal to the product of the other secant and its external segment.

[173]  $AC \times BC = CD \times CE.$

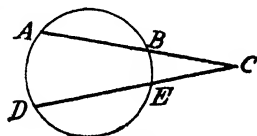

FIG. 207.

**554. Annulus.**—[174]  $Area = \pi(R^2 - r^2) = \frac{\pi(D^2 - d^2)}{4} = 2\pi R'b.$

[175]  $R' = \frac{R + r}{2}.$

[176]  $b = R - r.$



FIG. 208

**555. Sector.**

$C$  = chord.

[177]  $C = 2r \sin \frac{A}{2}$  ( $A$  expressed in radians).

[178]  $= 2r \sin \left( \frac{90S}{\pi r} \right)^\circ.$

$S$  = length of arc.

$S = \frac{\pi r A}{180}$  ( $A$  expressed in degrees).

$= rA$  ( $A$  expressed in radians).

[179]  $Area = \frac{rS}{2} = \pi r^2 \frac{A}{360}$  ( $A$  expressed in degrees).

$= \frac{r^2 A}{2}$  ( $A$  expressed in radians).

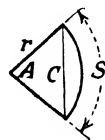

FIG. 209.

**556. Area of Sector of Annulus.**

[180]  $Area = \pi \frac{A(R^2 - r^2)}{360}$ , where

$A$  = angle in degrees.

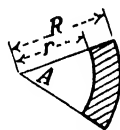

FIG. 210.

**557. Segment.**

[181]  $C$  = chord  $= 2r \sin \frac{A}{2}$

( $A$  expressed in radians or degrees), or

$C = 2r \sin \left( \frac{90S}{\pi r} \right)^\circ = 2\sqrt{2hr - h^2}.$

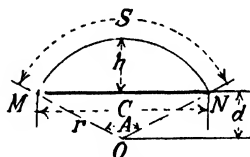

FIG. 211.

[182]  $S$  = length of arc  $= \frac{\pi r A}{180}$  ( $A$  expressed in degrees).

$= 2r \frac{A}{2}$ , or  $rA$  ( $A$  expressed in radians).

[183]  $h = r - d = r \left( 1 - \cos \frac{A}{2} \right)$  ( $A$  measured in radians or degrees).

[184]  $d = r \cos \frac{A}{2}$  ( $A$  measured in radians or degrees).

$= \frac{\sqrt{4r^2 - C^2}}{2}.$

**558. Area of Segment of a Circle.**

Area of segment = Area of sector  $MONS$  - Area of  $\Delta MON$ , in Fig. 211.

$$[185] \quad \text{Area} = \frac{r^2}{2} (A - \sin A), \quad A \text{ in radians.}$$

$$= \frac{r}{2} \left( S - r \sin \frac{S}{r} \right), \quad \frac{S}{r} \text{ in radians.}$$

$$\text{Area} = r^2 \cos^{-1} \frac{d}{r} - d \sqrt{r^2 - d^2}, \quad \cos^{-1} \frac{d}{r} \text{ in radians.}$$

$$= r^2 \cos^{-1} \frac{r-h}{r} - (r-h) \sqrt{2rh - h^2}, \quad \cos^{-1} \frac{r-h}{r} \text{ in radians.}$$

$$[186] \quad = \frac{r(S - C) + Ch}{2}.$$

$$= r^2 \sin^{-1} \frac{C}{2r} - \frac{C}{4} \sqrt{4r^2 - C^2}, \quad \sin^{-1} \frac{C}{2r} \text{ in radians.}$$

The last formula given applies only to segments less than half a circle. It is also possible in cases where the segment is greater than half a circle to obtain its area by subtracting the area of the smaller segment from the area of the circle.

Area of segment = Area of circle - Area of segment  $MNS$ .



FIG. 212.

**Fillet.**

$$[187] \quad \text{Area} = .215r^2 = \frac{1}{4}r^2 \text{ (approximately).}$$

**559. Ellipse.**—The ellipse is the locus of a point that moves in such a way that the sum of its distances from two fixed points, called the foci, is constant.

$$[188] \quad \text{Perimeter (approximately)} = a(4 + 1.1m + 1.2m^2),$$

where 
$$m = \frac{b}{a}.$$

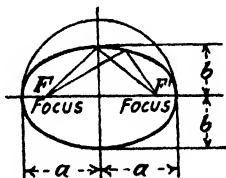

FIG. 213.

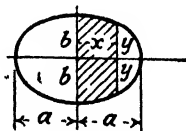

FIG. 214.

$$[189] \quad \text{Area} = \pi ab.$$

$$[190] \quad \text{Area of shaded segment} = xy + ab \sin^{-1} \frac{x}{a}.$$



**560. Parabola.**—A parabola is the locus of a point which moves in such a way as to keep its distance from a fixed line called the directrix equal to its distance from a fixed point, called the focus.

[191] Length of arc  $AOB = \frac{c}{2} \left[ \sqrt{n^2 + 1} + \frac{1}{n} \log_e (\sqrt{n^2 + 1} + n) \right]$   
 $= \frac{c}{2} \left[ \sqrt{n^2 + 1} + \frac{1}{n} \sin h^{-1} n \right]$ ,  
 where  $n = \frac{4h}{c}$ .

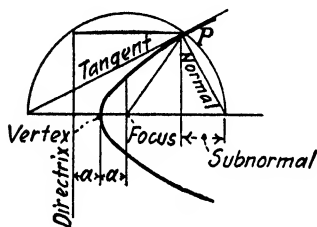

FIG. 215.

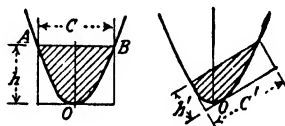

FIG. 216.

Area of segment cut off by any chord  $C$  or  $C'$  is  $\frac{2}{3}Ch$ , or  $\frac{2}{3}C'h'$ .  
 The area is equivalent to two-thirds the area of a rectangle having sides equal to  $C$  and  $h$ .

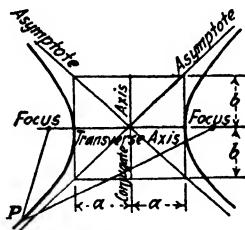

FIG. 217.

**561. Hyperbola.**—The hyperbola is the locus of a point which moves in such a way that the difference of its distances from two fixed points, called the foci, is constant.

[192] Shaded area  $= ab \log_e \left( \frac{x}{a} + \frac{y}{b} \right)$ .

In an equilateral hyperbola,

$$a = b.$$

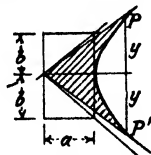

FIG. 218.

[193] Shaded area =  $a^2 \log \left( \frac{x + y}{a} \right) = a^2 \log \left( \frac{a}{x - y} \right)$ .  
 $= a^2 \sinh^{-1} \frac{y}{a}$ , or  $a^2 \cosh^{-1} \frac{x}{a}$ .

562. Cycloid.—A curve described by a point on a circle which rolls along a fixed straight line is called a cycloid.

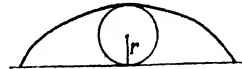

FIG. 219.

[194] Length of arc =  $S = 8r$ .

[195] Area =  $3\pi r^2$ .

563. Irregular Areas.—Simpson's rule, which is the most accurate of the strip methods, is applied as follows:

Divide the figure into an even number of strips of equal width. The smaller the width of the strips, the more accurate will be the result.

The formula is

[196] Area =  $\frac{h}{3} [(y_0 + y_n) + 4(y_1 + y_3 + y_5 + \dots) + 2(y_2 + y_4 + y_6 + \dots)]$ .

Stating the rule in words and referring to the above figure, the area is equal to the product of a third of the width of the strips into the sum of the first and last ordinate, plus four times the sum of the ordinates with odd subscripts, plus two times the sum of the ordinates with even subscripts, omitting the first and last ordinates.

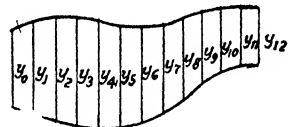

FIG. 220.

SURFACES AND SOLIDS

564. Cubes.

[197] Volume =  $a^3$ .

[198] Total surface area =  $6a^2$ .

[199] Diagonal  $d = a\sqrt{3}$ .

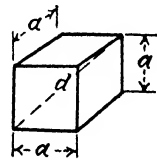

FIG. 221.

565. Rectangular Prism.

[200] Volume = Area of base  $\times$  Height =  $blh$ .

[201] Total surface area =  $2(lb + lh + bh)$ .

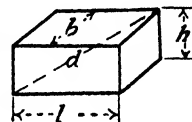

FIG. 222.

[202] Diagonal  $d = \sqrt{b^2 + l^2 + h^2}$ .

**566. Regular Hexagonal Prism.**

[203] Volume =  $\frac{3}{2}\sqrt{3}a^2h = 2.6a^2h = \frac{1}{2}\sqrt{3}f^2h = .866f^2h.$

[204] Lateral surface area =  $6ah = 2\sqrt{3}fh = 3.46fh.$

[205] Area of base =  $\frac{3}{2}\sqrt{3}a^2 = 2.6a^2.$

[206] Total surface area =  $6a(h + \frac{1}{2}\sqrt{3}a) = 6a(h + .866a).$

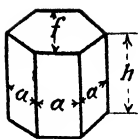

FIG. 223.

**567. Regular Octagonal Prism.**

[207] Volume =  $2(\sqrt{2} + 1)a^2h = 4.83a^2h = \frac{2(1 + \sqrt{2})}{1 + 2\sqrt{2} + 2}f^2h = .829f^2h.$

[208] Lateral surface area =  $8ah = \frac{8}{1 + \sqrt{2}}fh = 3.32fh.$

[209] Area of base =  $2(1 + \sqrt{2})a^2 = 4.828a^2.$

[210] Total surface area =  $8a(h + \frac{1}{2}a + \frac{1}{2}\sqrt{2}a) = 8a(h + 1.207a).$

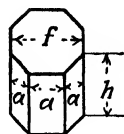

FIG. 224.

**568. Cylinder (Right Circular).**

[211] Volume =  $\pi r^2h = .7854d^2h.$

[212] Lateral surface area =  $2\pi rh.$

[213] Area of base =  $\pi r^2.$

[214] Total surface area =  $2\pi r(h + r).$



FIG. 225.

**569. Hollow Cylinder.**

[215] Volume =  $\pi h(R^2 - r^2).$

[216] Outer lateral surface area =  $2\pi Rh.$

[217] Inner lateral surface area =  $2\pi rh.$

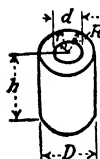

FIG. 226.

**570. Any Prism or Cylinder.**

[218] Volume =  $h \times$  Area of base.

[219] Lateral surface area =  $l \times$  Perimeter of normal section.

**571. Truncated Right Circular Cylinder.**

[220]  $h =$  mean height =  $\frac{h_1 + h_2}{2}.$

[221] Volume =  $2\pi rh = h \times$  Area of base.

[222] Lateral surface area =  $2\pi rh.$

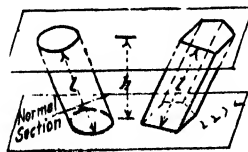

FIG. 227.

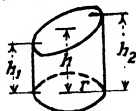

FIG. 228.

**572. Any Truncated Prism or Cylinder.**

[223] Volume = Distance between centers of gravity of the two bases  $\times$  Area of normal section.

[224] Lateral area = Perimeter of normal section  $\times$  Distance between centers of gravity of the two perimeters.

**573. Regular Pyramid or Cone.**

[225] Volume =  $\frac{1}{3}$  (Area of base  $\times$  Altitude  $h$ ).

[226] Lateral area of regular figure =  $\frac{1}{2}$  (Perimeter of base  $\times$  Slant height  $S$ ).

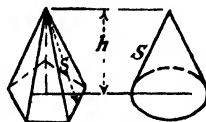

FIG. 229.

**574. Any Pyramid or Cone.**

[227] Volume =  $\frac{1}{3}$  (Area of base  $\times$  Distance from vertex to plane of base).

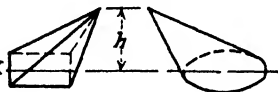

FIG. 230.

**575. Frustum of Any Pyramid or Cone.**

[228] Volume =  $\frac{h}{3}(A_1 + A_2 + \sqrt{A_1 \times A_2})$ , where  $A_1$  and  $A_2$  are areas of bases made by parallel planes.

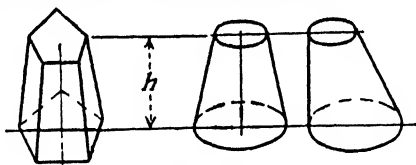

FIG. 231.

**576. Sphere.**

[229] Volume =  $\frac{4}{3}\pi r^3 = 4.1888r^3 = \frac{\pi}{6}D^3 = .5236D^3$ .

[230] Area =  $4\pi r^2 = 12.5664r^2 = \pi D^2$ .

The area of a sphere is the same as the lateral area of a circumscribed cylinder.

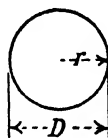

FIG. 232.

**577. Hollow Sphere.**

[231] Volume =  $\frac{4}{3}\pi(R^3 - r^3) = 4.1888(R^3 - r^3)$ .

$$= \frac{\pi}{6}(D^3 - d^3) = .5236(D^3 - d^3)$$

$$= 4\pi R_1^2 t + \frac{\pi}{3}t^3,$$

where  $R_1$  = mean radius =  $\frac{R + r}{2}$  and

$t$  = thickness of shell.

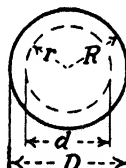

FIG. 233.

**578. Spherical Segment.**

[232] Volume of segment of one base =  $\frac{\pi h}{6} (3r^2 + h^2) = .5236h(3r^2 + h^2)$ .

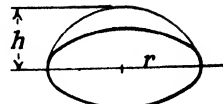

FIG. 234.

[233] Volume of segment of two bases =  $\frac{\pi h}{6} [3(r_2^2 + r_1^2) + h^2]$ .

**579. Spherical Zone.**

[234] Area =  $2\pi R(R - \sqrt{R^2 - r^2})$   
 $= 2\pi R h,$

where  $R$  is the radius of the sphere.

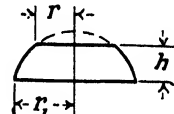

FIG. 235.

**580. Spherical Sector.**

[235] Volume =  $\frac{2}{3}\pi r^2 h.$

[236] Total area =  $2\pi r h + \pi r a = \pi r(2h + a).$

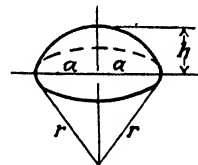

FIG. 236.

**581. Ellipsoid.**

[237] Volume =  $\frac{4}{3}\pi abc = 4.1888 abc.$



FIG. 237.

**582. Paraboloid of Revolution.**

[238] Volume =  $\frac{\pi}{2} r^2 h = \frac{1}{2}$  Volume of circumscribed cylinder.

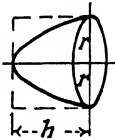

FIG. 238.

**583. Paraboloidal Segment.**

[239] Volume =  $\frac{1}{2}\pi h(r_1^2 + r_2^2).$

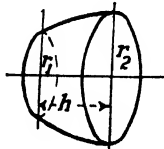

FIG. 239.

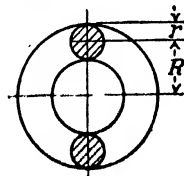

FIG. 240.

**584. Torus.**

[240] Volume =  $2\pi^2 R r^2.$

[241] Surface =  $4\pi^2 R r.$

## PRISMOIDAL FORMULA

**585.** To find the volume of any prismatic solid,

$$[242] \text{ Volume} = \frac{L}{6}(A + B + 4M),$$

where  $L$  = distance between parallel sides.

$A$  and  $B$  are the areas of end sections and  $M$  is the average middle section.

This formula is very useful in figuring excavations.

Referring to Fig. 241.

Area  $A = 60$ ,  $B = 108$ ,  $M = 84$ ,  $L = 18$ .

Volume =  $\frac{1}{6}(60 + 108 + 4 \cdot 84) = 1512$ .

**586. Wedge-shaped Volume.**—The prismatic formula can be applied to wedge-shaped excavations (Fig. 242).

$$A = \frac{30 \times 16}{2} = 240.$$

$$B = \frac{50 \times 20}{2} = 500.$$

$$M = \frac{40 \times 18}{2} = 360.$$

$$[243] \text{ Volume} = \frac{1}{6}(240 + 500 + 4 \cdot 360) = 21,800.$$

In a railroad cut with the slope  $S$  horizontal to 1 vertical, for both sides, the area of  $ABCD$  =  $h(2a + hS)$ , where

$2a$  = base of cut and

$h$  = height of surface from base of cut.

Apply these areas to prismatic formula,

$$\text{Volume} = \frac{L}{6}(A + B + 4M) \quad [242],$$

to get volume.

Another Case.

$$[244] \text{ Area of section} = \frac{mn - a^2}{S}.$$

Slope is  $S$  horizontal to 1 vertical, as above.

Use prismatic formula as before.

Railroad fills can be figured in the same manner.

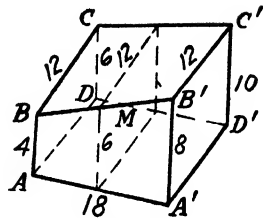

FIG. 241.

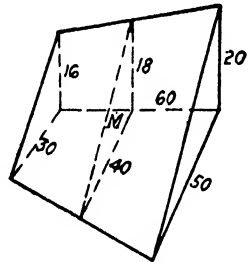

FIG. 242.

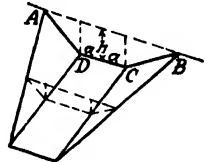

FIG. 243.

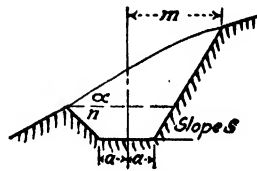

FIG. 244.

**587. Simpson's Rule Applied to Volumes.**—To find the volume, compute the areas  $A_0, A_1$ , etc., and substitute in

$$[245] \text{ Volume} = \frac{h}{3} [(A_0 + A_n) + 4(A_1 + A_3 + A_5 + \dots) + 2(A_2 + A_4 + A_6 + \dots)].$$

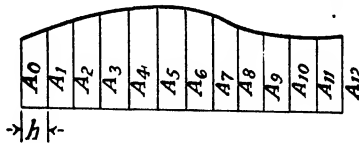

FIG. 245.

There must be an even number of strips, spaced equally.

$A_0$  is the first area and  $A_n$  is the last area.

$A_1, A_3, A_5$  are the areas with odd subscripts, and

$A_2, A_4, A_6$  are the areas with even subscripts.

**588.** The volume of water can be computed by getting areas of contours and using Simpson's rule to get the volume, using areas as in the previous article.

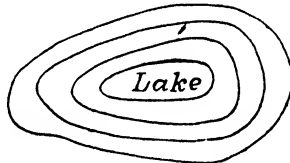

FIG. 246.

## CHAPTER XXIII

### TRIGONOMETRIC FUNCTIONS

**589. Angular magnitude** is measured by the amount of rotation of a line about a fixed point.

If the rotation is measured in a counterclockwise direction, the angle is positive.

If the rotation is measured in a clockwise direction, the angle is negative.

Angular magnitude is unlimited in respect to size.

The most common units of measurement of angular magnitude are the degree and the radian.

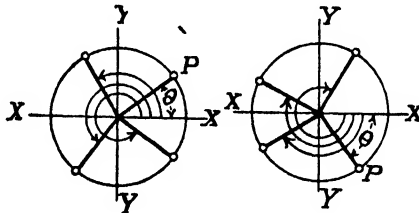

FIG. 247.

In the degree system, the unit is the angle corresponding to  $\frac{1}{360}$  of a complete rotation.

**590. The radian**, the unit of circular measure, is an angle at the center of a circle, subtended by an arc that is equal in length to the radius.

$$2\pi r = \text{circumference of a circle.}$$

Since a radian is an angle subtended by an arc equal to  $r$ , there are as many radians at the center of the circle as  $r$  is contained in  $2\pi r$ , or the angular magnitude about the center is

$$\frac{2\pi r}{r} = 2\pi = 6.2832 \text{ radians.}$$



The angular magnitude about the center is also  $360^\circ$ . Hence,

$$2\pi \text{ radians} = 360^\circ.$$

$$\pi \text{ radians} = 180^\circ.$$

$$1 \text{ radian} = \frac{180^\circ}{\pi} = 57.29578^\circ -$$

$$1^\circ = \frac{\pi}{180} = .0174533 \text{ radian.}$$

**591.** In the study of trigonometry, we will consider angles in two senses:

*First.* As generated by a line rotating to a certain point and the relations of the various functions at that point.

*Second.* A continuous rotation as indicated by the graphs of more than  $360^\circ$ , or one revolution, and also when the velocity is a consideration.

**592.** Given several concentric circles and an angle  $AOB$  at the center. Then

$$\frac{\text{arc } P_1Q_1}{OP_1} = \frac{\text{arc } P_2Q_2}{OP_2} = \frac{\text{arc } P_3Q_3}{OP_3}.$$

That is, the ratio of the intercepted arc to the radius of that arc is a constant for all circles when the angle is the same.

The angle at the center that makes this ratio unity is, then, a convenient unit for measuring angles.

This unit, as we have seen, is called a *radian*.

In the same or in equal circles two angles at the center are in the same ratio as their intercepted arcs.

$$\frac{\angle AOB}{\angle AOC} = \frac{\text{arc } AB}{\text{arc } AC}.$$

Then, if  $\angle AOC$  is unity when arc  $AC$  is equal to  $r$ ,

$$\angle AOB = \frac{\text{arc } AB}{r},$$

or, in general,

$$\theta = \frac{S}{r} \text{ (see [164] et seq.),}$$

where  $\theta$  is the angle at the center measured in radians,  $S$  is the length of its subtended arc, and  $r$  is the radius of the circle.

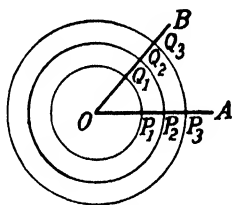

FIG. 248.

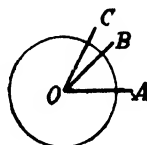

FIG. 249.

From this, we have  $S = r\theta$ , which states that the length of the subtended arc equals the product of the radius and the angle at the center measured in radians.

**593. Coordinates.**—The point  $P$  can be located by means of the  $x$  and  $y$ , or rectangular coordinates which need no explanation, or by means of polar coordinates.

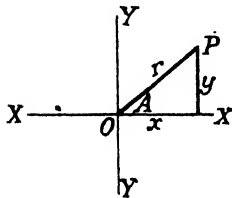

FIG. 250.

In the polar system of coordinates, the point is located by the distance  $r$ , called the *radius vector*, and the angle  $A$  called the *vectorial angle*.

The radius vector is usually designated by  $\rho$  and the vectorial angle by  $\theta$ .

**594. Functions of Angles.**

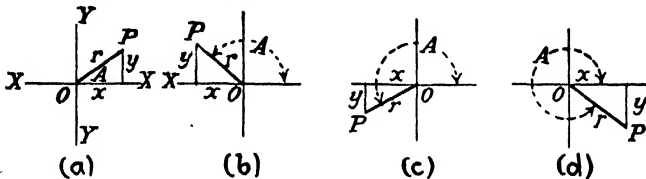

FIG. 251.

If we place the angle  $A$  with its vertex at the origin and its initial side on the positive end of the  $X$ -axis, and if we allow the terminal side of the angle to fall where it will, and if  $P$  with coordinates  $(x, y)$  is any point on the terminal side and  $r$  its distance from the origin, the ratios between  $r$ ,  $x$ , and  $y$  are the trigonometric functions of the angle  $A$ .

The sign of  $r$  is always taken as positive.

The sign of the function is determined from the signs of the coordinates of  $P$ ; that is, the sign of the function is determined by the quadrant in which the point  $P$  is located.

These ratios are named as follows:

$$[246] \quad \text{Sine } A = \frac{y}{r}.$$

$$[247] \quad \text{Cosine } A = \frac{x}{r}.$$

$$[248] \quad \text{Tangent } A = \frac{y}{x}.$$

$$[249] \quad \text{Cotangent } A = \frac{x}{y}.$$

$$[250] \quad \text{Secant } A = \frac{r}{x}.$$

$$[251] \quad \text{Cosecant } A = \frac{r}{y}.$$

If  $r$  is taken as unity, then

[252]  $\sin A = y.$                       [253]  $\cos A = x.$

[254]  $\sec A = \frac{1}{x}.$                       [255]  $\csc A = \frac{1}{y}.$

From geometry, we have  $r^2 = x^2 + y^2$ . Then

[256]  $r = \sqrt{x^2 + y^2} = \frac{y}{\sin A} = \frac{x}{\cos A} = x \sec A = y \csc A.$

[257]  $x = \sqrt{r^2 - y^2} = r \cos A = \frac{y}{\tan A} = y \cot A = \frac{r}{\sec A}.$

[258]  $y = \sqrt{r^2 - x^2} = r \sin A = x \tan A = \frac{x}{\cot A} = \frac{r}{\csc A}.$

595. Reciprocal relations of functions are evident, as:

[259]  $\sin A = \frac{1}{\csc A}.$                       [260]  $\csc A = \frac{1}{\sin A}.$

[261]  $\cos A = \frac{1}{\sec A}.$                       [262]  $\sec A = \frac{1}{\cos A}.$

[263]  $\tan A = \frac{1}{\cot A}.$                       [264]  $\cot A = \frac{1}{\tan A}.$

596. Functions of Some Special Angles.—From geometry, we know that the side opposite the  $30^\circ$  angle is one-half the hypotenuse in a right triangle with one acute angle equal to  $30^\circ$ .

Taking  $y = 1$ , then

$$\begin{aligned} \sin 30^\circ &= \frac{1}{2}. \\ \cos 30^\circ &= \frac{1}{2}\sqrt{3} \\ \tan 30^\circ &= \frac{1}{3}\sqrt{3}. \\ \cot 30^\circ &= \sqrt{3}. \\ \sec 30^\circ &= \frac{2}{3}\sqrt{3}. \\ \csc 30^\circ &= 2. \end{aligned}$$

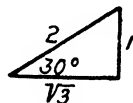

FIG. 252.

In the same manner, the functions of  $45^\circ$  and  $60^\circ$  can be computed.

597. If the angle is  $90^\circ$ , choose a point on the terminal side of the angle at a distance of  $a$  units from the origin. The coordinates of the point are  $(0, a)$  and  $r = a$ .

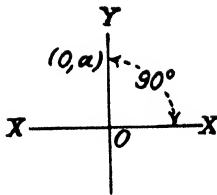

FIG. 253.

$$\sin 90^\circ = \frac{y}{r} = \frac{a}{a} = 1.$$

$$\cos 90^\circ = \frac{x}{r} = \frac{0}{a} = 0.$$

$$\tan 90^\circ = \frac{y}{x} = \frac{a}{0} = \alpha.$$

$$\cot 90^\circ = \frac{x}{y} = \frac{0}{a} = 0.$$

$$\sec 90^\circ = \frac{r}{x} = \frac{a}{0} = \alpha.$$

$$\csc 90^\circ = \frac{r}{y} = \frac{a}{a} = 1.$$

The notations,  $\tan 90^\circ = \alpha$  and  $\sec 90^\circ = \alpha$ , mean simply that these functions are not defined.

**598.** For the angle  $120^\circ$  we can get the relation of the sides from the case of the  $30^\circ$  angle, but since  $x$  in the case of  $120^\circ$  is negative, it will be equal to  $-1$ .

$$\sin 120^\circ = \frac{y}{r} = \frac{\sqrt{3}}{2} = \frac{1}{2}\sqrt{3}.$$

$$\cos 120^\circ = \frac{x}{r} = \frac{-1}{2} = -\frac{1}{2}.$$

$$\tan 120^\circ = \frac{y}{x} = \frac{\sqrt{3}}{-1} = -\sqrt{3}.$$

$$\cot 120^\circ = \frac{x}{y} = \frac{-1}{\sqrt{3}} = -\frac{1}{\sqrt{3}}\sqrt{3}.$$

$$\sec 120^\circ = \frac{r}{x} = \frac{2}{-1} = -2.$$

$$\csc 120^\circ = \frac{r}{y} = \frac{2}{\sqrt{3}} = \frac{2}{\sqrt{3}}\sqrt{3}.$$

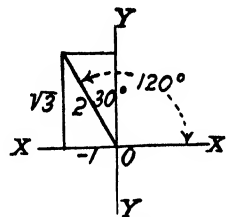

FIG. 254.

Continuing in this manner, a convenient table may be built for a number of common angles.

$\theta$ in degrees	$\theta^\circ$ in radians	$\sin \theta$	$\cos \theta$	$\tan \theta$	$\cot \theta$	$\sec \theta$	$\csc \theta$	Chords
0	0	0	1	0	$\alpha$	1	$\alpha$	0
30	$\frac{\pi}{6}$	$\frac{1}{2}$	$\frac{\sqrt{3}}{2}$	$\frac{\sqrt{3}}{3}$	$\sqrt{3}$	$\frac{2\sqrt{3}}{3}$	2	$\sqrt{2 - \sqrt{3}}$
45	$\frac{\pi}{4}$	$\frac{\sqrt{2}}{2}$	$\frac{\sqrt{2}}{2}$	1	1	$\sqrt{2}$	$\sqrt{2}$	$\sqrt{2 - \sqrt{2}}$
60	$\frac{\pi}{3}$	$\frac{\sqrt{3}}{2}$	$\frac{1}{2}$	$\sqrt{3}$	$\frac{\sqrt{3}}{3}$	2	$\frac{2\sqrt{3}}{3}$	1
90	$\frac{\pi}{2}$	1	0	$\alpha$	0	$\alpha$	1	$\sqrt{2}$
120	$\frac{2\pi}{3}$	$\frac{\sqrt{3}}{2}$	$-\frac{1}{2}$	$-\sqrt{3}$	$-\frac{\sqrt{3}}{3}$	-2	$\frac{2\sqrt{3}}{3}$	$\sqrt{3}$
135	$\frac{3\pi}{4}$	$\frac{\sqrt{2}}{2}$	$-\frac{\sqrt{2}}{2}$	-1	-1	$-\sqrt{2}$	$\sqrt{2}$	$\sqrt{2 + \sqrt{2}}$
150	$\frac{5\pi}{6}$	$\frac{1}{2}$	$-\frac{\sqrt{3}}{2}$	$-\frac{\sqrt{3}}{3}$	$-\sqrt{3}$	$-\frac{2\sqrt{3}}{3}$	2	$\sqrt{2 + \sqrt{3}}$
180	$\pi$	0	-1	0	$\alpha$	-1	$\alpha$	2
210	$\frac{7\pi}{6}$	$-\frac{1}{2}$	$-\frac{\sqrt{3}}{2}$	$\frac{\sqrt{3}}{3}$	$\sqrt{3}$	$-\frac{2\sqrt{3}}{3}$	-2	$\sqrt{2 + \sqrt{3}}$
225	$\frac{5\pi}{4}$	$-\frac{\sqrt{2}}{2}$	$-\frac{\sqrt{2}}{2}$	1	1	$-\sqrt{2}$	$-\sqrt{2}$	$\sqrt{2 + \sqrt{2}}$
240	$\frac{4\pi}{3}$	$-\frac{\sqrt{3}}{2}$	$-\frac{1}{2}$	$\sqrt{3}$	$\frac{\sqrt{3}}{3}$	-2	$-\frac{2\sqrt{3}}{3}$	$\sqrt{3}$
270	$\frac{3\pi}{2}$	-1	0	$\alpha$	0	$\alpha$	-1	$\sqrt{2}$
300	$\frac{5\pi}{3}$	$-\frac{\sqrt{3}}{2}$	$\frac{1}{2}$	$-\sqrt{3}$	$-\frac{\sqrt{3}}{3}$	2	$-\frac{2\sqrt{3}}{3}$	1
315	$\frac{7\pi}{4}$	$-\frac{\sqrt{2}}{2}$	$\frac{\sqrt{2}}{2}$	-1	-1	$\sqrt{2}$	$-\sqrt{2}$	$\sqrt{2 - \sqrt{2}}$
330	$\frac{11\pi}{6}$	$-\frac{1}{2}$	$\frac{\sqrt{3}}{2}$	$-\frac{\sqrt{3}}{3}$	$-\sqrt{3}$	$\frac{2\sqrt{3}}{3}$	-2	$\sqrt{2 - \sqrt{3}}$
360	$2\pi$	0	1	0	$\alpha$	1	$\alpha$	0

599. Graphical representation of trigonometric functions in the four quadrants with unit radius.

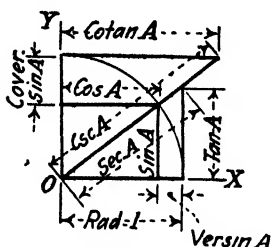

FIG. 255.

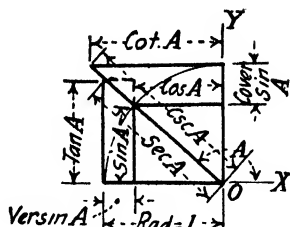

FIG. 256.

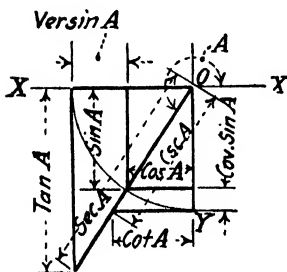

FIG. 257.

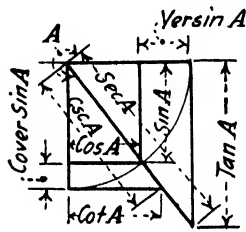

FIG. 258.

Any unit may be used, as 10 inches. In this case, the value of the function would be its length in inches divided by 10. Use a decimal scale and move the decimal point one place to the left.

600. Complementary Angles.—In all right triangles, the sum of  $\angle A$  and  $\angle B$  is equal to  $90^\circ$ , or each of the angles is the complement of the other. Any trigonometric ratio of one angle is equal to the coratio of the other. Hence, the "co" in cosine, cotangent, and cosecant indicates the sine, tangent, and secant, respectively, of the complementary angle, or

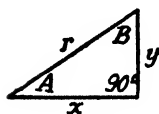

FIG. 259.

$$\sin A = \cos (90^\circ - A) = \cos B.$$

601. Signs of Trigonometric Functions.—To determine the sign of a function, consider the coordinates of a point  $P$  on the terminal line of the angle, thus (Fig. 260a),

$$\tan A = \frac{-y}{-x} \text{ (sign +),}$$

and (Fig. 260b)

$$\tan A = \frac{y}{-x} \text{ (sign -).}$$

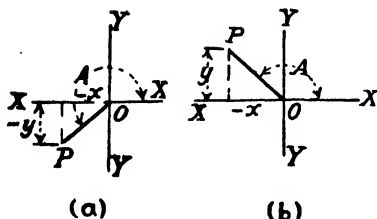

FIG. 260.

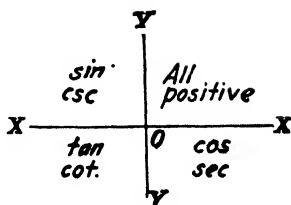

FIG. 261.

Figure 261 shows the location of the positive functions.

If the terminal line of the angle is in the first or fourth quadrants, the cosine function, for example, is positive. In the second and third quadrants, the cosine is negative.

*vers* and *covers* are always positive.

**602. Functions of Negative Angles.**—Draw angles  $A$  and  $-A$  where  $OP$  is the terminal line of  $A$ , and  $OP'$  is the terminal line of  $-A$  in the four quadrants.

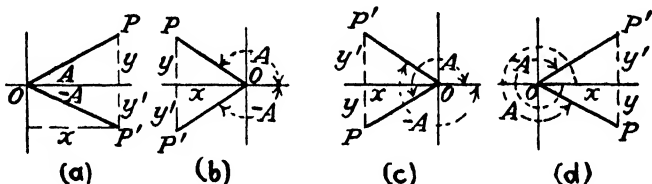

FIG. 262.

If, now, we let the coordinates of  $P$  and  $P'$  be  $(x, y)$  and  $(x', y')$ , respectively, then

$$x = x', \quad y = -y', \quad r = r',$$

and

$$\sin (-A) = \frac{y'}{r'} = \frac{-y}{r} = -\sin A.$$

$$\cos (-A) = \frac{x'}{r'} = \frac{x}{r} = \cos A.$$

$$\tan (-A) = \frac{y'}{x'} = \frac{-y}{x} = -\tan A.$$

$$\cot (-A) = \frac{x'}{y'} = \frac{x}{-y} = -\cot A.$$

$$\sec (-A) = \frac{r'}{x'} = \frac{r}{x} = \sec A.$$

$$\csc (-A) = \frac{r'}{y'} = \frac{r}{-y} = -\csc A.$$

**603. Functions of angles**  $\left(n\frac{\pi}{2} \pm \theta\right)$  as  $\sin (90^\circ + \theta)$ ,  $\cos (180^\circ - \theta)$ ,  $\sin (\theta - 90^\circ)$ , etc.

To reduce these angles to equivalent acute angles (less than  $90^\circ$ ), express the angle as a multiple of  $90^\circ$  or  $\frac{\pi}{2}$ , as

$$n\frac{\pi}{2} \pm \theta, \text{ or } n \times 90^\circ \pm \theta.$$

If  $n$  is even, take the same function of  $\theta$  as of the original angle; if  $n$  is odd, take the cofunction of  $\theta$  (Art. 600). In either case, prefix the algebraic sign of the original function to the function of the acute angle  $\theta$ .

That is, if  $n\frac{\pi}{2} + \theta$  is in the third quadrant, the coordinates of a point in the third quadrant would determine the sign of the function (see Art. 601).

**EXAMPLE.**— $\sin 680^\circ = \sin (7 \times 90 + 50)$ .  $n$  is odd. Sin in the fourth quadrant is negative. Then  $\sin 680^\circ = -\cos 50^\circ$ .

#### 460. Relations of Functions of an Angle.

$$\sin A = \frac{y}{r} \quad [246].$$

$$\cos A = \frac{x}{r} \quad [247].$$

$$\tan A = \frac{y}{x} \quad [248].$$

$$\cot A = \frac{x}{y} \quad [249].$$

$$\sec A = \frac{r}{x} \quad [250].$$

$$\csc A = \frac{r}{y} \quad [251].$$

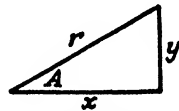

FIG. 263.



$$r = \sqrt{x^2 + y^2} = \frac{y}{\sin A} = \frac{x}{\cos A} = x \sec A = y \csc A \quad [256].$$

$$x = \sqrt{r^2 - y^2} = r \cos A = \frac{y}{\tan A} = y \cot A = \frac{r}{\sec A} \quad [257].$$

$$y = \sqrt{r^2 - x^2} = r \sin A = x \tan A = \frac{x}{\cot A} = \frac{r}{\csc A} \quad [258].$$

[265]  $\sin^2 A + \cos^2 A = 1.$

[266]  $\sec^2 A - \tan^2 A = 1.$

[267]  $\csc^2 A - \cot^2 A = 1.$

[268]  $\sin A \csc A = 1$  [259, 260].

[269]  $\cos A \sec A = 1$  [261, 262].

[270]  $\tan A \cot A = 1$  [263, 264].

[271]  $\sin A < A < \tan A$  (if  $0 < A < 90^\circ$ ).

$$\text{Limit}_{A \rightarrow 0} \left[ \frac{A}{\sin A} \right] = 1.$$

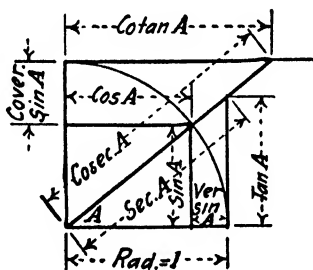

FIG. 264.

$$[272] \sin A = \frac{\cos A}{\cot A} = \frac{1}{\csc A} = \cos A \tan A = \sqrt{1 - \cos^2 A} = \frac{\tan A}{\sqrt{1 + \tan^2 A}} = \frac{1}{\sqrt{1 + \cot^2 A}} = \frac{\sqrt{\sec^2 A - 1}}{\sec A} =$$

$$2 \sin \frac{A}{2} \cos \frac{A}{2} = \pm \sqrt{\frac{1 - \cos 2A}{2}}$$

$$[273] \cos A = \frac{\sin A}{\tan A} = \frac{1}{\sec A} = \sin A \cot A = \sqrt{1 - \sin^2 A} = \frac{1}{\sqrt{1 + \tan^2 A}} = \frac{\cot A}{\sqrt{1 + \cot^2 A}} = \frac{\sqrt{\csc^2 A - 1}}{\csc A} =$$

$$\cos^2 \frac{A}{2} - \sin^2 \frac{A}{2} = \pm \sqrt{\frac{1 + \cos 2A}{2}}$$

$$\begin{aligned}
 [274] \quad \tan A &= \frac{\sin A}{\cos A} = \frac{1}{\cot A} = \sin A \sec A = \sqrt{\sec^2 A - 1} = \\
 &= \frac{\sin A}{\sqrt{1 - \sin^2 A}} = \frac{\sqrt{1 - \cos^2 A}}{\cos A} = \frac{1}{\sqrt{\csc^2 A - 1}} = \\
 &= \frac{2 \tan \frac{A}{2}}{1 - \tan^2 \frac{A}{2}} = \frac{\sec A}{\csc A}.
 \end{aligned}$$

$$\begin{aligned}
 [275] \quad \cot A &= \frac{\cos A}{\sin A} = \frac{1}{\tan A} = \cos A \csc A = \sqrt{\csc^2 A - 1} = \\
 &= \frac{\sqrt{1 - \sin^2 A}}{\sin A} = \frac{\cos A}{\sqrt{1 - \cos^2 A}} = \frac{1}{\sqrt{\sec^2 A - 1}} = \\
 &= \frac{\csc A}{\sec A}.
 \end{aligned}$$

$$\begin{aligned}
 [276] \quad \sec A &= \frac{\tan A}{\sin A} = \frac{1}{\cos A} = \frac{1}{\sqrt{1 - \sin^2 A}} = \sqrt{1 + \tan^2 A} = \\
 &= \frac{\sqrt{1 + \cot^2 A}}{\cot A} = \frac{\csc A}{\sqrt{\csc^2 A - 1}}.
 \end{aligned}$$

$$\begin{aligned}
 [277] \quad \csc A &= \frac{\cot A}{\cos A} = \frac{1}{\sin A} = \frac{1}{\sqrt{1 - \cos^2 A}} = \sqrt{1 + \cot^2 A} = \\
 &= \frac{\sqrt{1 + \tan^2 A}}{\tan A} = \frac{\sec A}{\sqrt{\sec^2 A - 1}}.
 \end{aligned}$$

$$[278] \quad \sin(A \pm B) = \sin A \cos B \pm \cos A \sin B.$$

$$[279] \quad \cos(A \pm B) = \cos A \cos B \mp \sin A \sin B.$$

$$[280] \quad \tan(A \pm B) = \frac{\tan A \pm \tan B}{1 \mp \tan A \tan B}.$$

$$[281] \quad \cot(A \pm B) = \frac{\cot A \cot B \mp 1}{\cot B \pm \cot A}.$$

$$[282] \quad \sin A + \sin B = 2 \sin \frac{1}{2}(A + B) \cos \frac{1}{2}(A - B).$$

$$[283] \quad \sin A - \sin B = 2 \cos \frac{1}{2}(A + B) \sin \frac{1}{2}(A - B).$$

$$[284] \quad \cos A + \cos B = 2 \cos \frac{1}{2}(A + B) \cos \frac{1}{2}(A - B).$$

$$[285] \quad \cos A - \cos B = -2 \sin \frac{1}{2}(A + B) \sin \frac{1}{2}(A - B).$$

$$[286] \quad \tan A + \tan B = \frac{\sin(A + B)}{\cos A \cos B}.$$

$$[287] \quad \tan A - \tan B = \frac{\sin(A - B)}{\cos A \cos B}.$$

$$[288] \quad \cot A + \cot B = \frac{\sin(A+B)}{\sin A \sin B}.$$

$$[289] \quad \cot A - \cot B = \frac{\sin(B-A)}{\sin A \sin B}.$$

$$[290] \quad \sin 2A = 2 \sin A \cos A.$$

$$[291] \quad \cos 2A = \cos^2 A - \sin^2 A = 1 - 2 \sin^2 A = 2 \cos^2 A - 1.$$

$$[292] \quad \tan 2A = \frac{2 \tan A}{1 - \tan^2 A}.$$

$$[293] \quad \cot 2A = \frac{\cot^2 A - 1}{2 \cot A}.$$

$$[294] \quad \sin \frac{1}{2}A = \pm \sqrt{\frac{1 - \cos A}{2}}.$$

$$[295] \quad \cos \frac{1}{2}A = \pm \sqrt{\frac{1 + \cos A}{2}}.$$

$$[296] \quad \tan \frac{1}{2}A = \pm \sqrt{\frac{1 - \cos A}{1 + \cos A}} = \frac{1 - \cos A}{\sin A} = \frac{\sin A}{1 + \cos A}.$$

$$[297] \quad \sin^2 A = \frac{1 - \cos 2A}{2}.$$

$$[298] \quad \cos^2 A = \frac{1 + \cos 2A}{2}.$$

$$[299] \quad \sin^2 A - \sin^2 B = \sin(A+B) \sin(A-B).$$

$$[300] \quad \cos^2 A - \sin^2 B = \cos(A+B) \cos(A-B).$$

$$[301] \quad \tan^2 A = \frac{1 - \cos 2A}{1 + \cos 2A}.$$

$$[302] \quad \cot^2 A = \frac{1 + \cos 2A}{1 - \cos 2A}.$$

$$[303] \quad \tan \frac{1}{2}(A \pm B) = \frac{\sin A \pm \sin B}{\cos A + \cos B}.$$

$$[304] \quad \cot \frac{1}{2}(A \pm B) = \frac{\sin A \mp \sin B}{\cos B - \cos A}.$$

$$[305] \quad \sin A \cos B = \frac{1}{2}[\sin(A+B) + \sin(A-B)].$$

$$[306] \quad \cos A \sin B = \frac{1}{2}[\sin(A+B) - \sin(A-B)].$$

$$[307] \quad \cos A \cos B = \frac{1}{2}[\cos(A+B) + \cos(A-B)].$$

$$[308] \quad \sin A \sin B = -\frac{1}{2}[\cos(A+B) + \cos(A-B)].$$

**605.** When  $\theta$  is small,  $\sin \theta$ ,  $\tan \theta$ , and angle  $\theta$  measured in radians are approximately equal.

EXAMPLE.

$$\sin 2^\circ = .0349 \text{ from tables.}$$

$$\tan 2^\circ = .0349 \text{ from tables.}$$

$$2^\circ \text{ in radians} = .0349 \text{ from tables.}$$

If a slightly larger angle is used, a small difference appears in the tables, but even this difference can be disregarded if within the limits of the approximation.

The usefulness of this is apparent, for the angle in radians can be substituted if either the sine or tangent is given and a tedious operation with decimals avoided.

**606. Another Approximation.**—When  $x$  is small and given in radians,

$$\cos x = 1 - \frac{1}{2}x^2.$$

EXAMPLE.

$$\cos .006 = 1 - .000018 = .999982.$$

## CHAPTER XXIV

### GRAPHS OF TRIGONOMETRIC FUNCTIONS

**607. Graph of Sine Function.**—Consider the function,

$$y = \sin x,$$

where  $x$  is the radian measure of the angle.

Plot the graph of the function, using rectangular coordinates, with  $x$  the abscissa of any point being the number of radians in the angle, and  $y$  the ordinate being the sine of the corresponding angle.

The graph cuts the  $X$ -axis where

$$x = 0, \pi, 2\pi, 3\pi, 4\pi, \dots, k\pi,$$

and where

$$x = -\pi, -2\pi, -3\pi, -4\pi, \dots, -k\pi,$$

$k$  being any positive or negative integer, or zero.

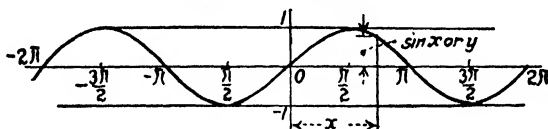

FIG. 265.

As the angle  $x$  increases from 0 to  $\frac{\pi}{2}$ ,  $y$  increases from 0 to 1.

As the angle  $x$  increases from  $\frac{\pi}{2}$  to  $\pi$ ,  $y$  decreases from 1 to 0.

As the angle  $x$  increases from  $\pi$  to  $\frac{3\pi}{2}$ ,  $y$  decreases from 0 to  $-1$ .

As the angle  $x$  increases from  $\frac{3\pi}{2}$  to  $2\pi$ ,  $y$  increases from  $-1$  to 0.

It will be readily seen from the graph that for real values of  $x$ ,  $y$  cannot be greater than 1 nor less than  $-1$ . Values of  $x$  that make  $y$  greater in absolute value than 1 are imaginary.

The sine function is a periodic function having a period of  $2\pi$  or  $360^\circ$ . This means that the graph of the function is repeated during each revolution and that  $y$  has the same value for all values of  $x$  that differ from one another by multiples of  $2\pi$ .

**608. Construction of Sine Graph.**—Lay off convenient angles as abscissa and take the sines of these angles as ordinates, as shown in Fig. 266. Referring to Art. 599 showing graphical representation of  $\sin A$ , we note  $PB = \sin A$  for each location of  $P$ .

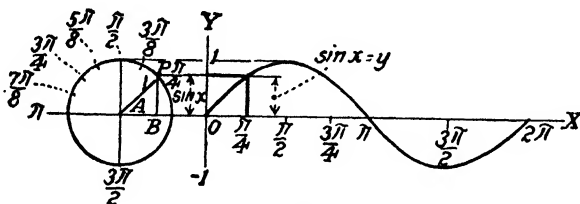

FIG. 266.

**609. Graph of  $\sin(x + B)$ .**—Assume the graph of  $y = \sin x_1$ .

We have the graph of  $y = \sin x_1$  with origin at  $O_1$  and we desire to shift the origin to  $O$  and write an equation in  $x$  and  $y$  referred to the new axis.

From the figure,  $x_1 = x + B$ .

Substituting in  $y = \sin x_1$  gives

$$y = \sin(x + B).$$

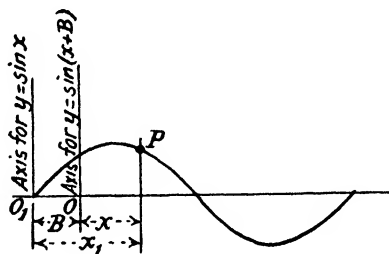

FIG. 267.

This change from  $\sin x_1$  to  $\sin(x + B)$  simply means a translation of the origin of  $y = \sin x_1$ , a distance representing angle  $B$  in the  $X$ -direction to make the graph become the graph of  $y = \sin(x + B)$ .

In making a graph of  $y = \sin(x + B)$ , start with a standard  $y = \sin x$  graph. If  $B$  is positive, shift the origin in the positive direction of  $x$  and if  $B$  is negative, shift the origin in the negative direction of  $x$  to locate the origin of the graph for  $y = \sin(x + B)$ . The distance shifted is the distance which represents the value of  $B$ .

We recommend that a standard graph of  $y = \sin x$  be kept on hand, and by shifting the origin, any graph of the form  $y = \sin(x + B)$  can easily be made by locating a new origin.

If  $\angle B = \frac{\pi}{2}$ , we have

$$\sin\left(x + \frac{\pi}{2}\right) = \sin(x + 90^\circ),$$

and since the cosine of an angle equals the sine of its complement, we may write

$$\sin(x + 90^\circ) = \cos x,$$

which shows that the sine graph and the cosine graph are similar except for a translation of the ordinates through a distance which represents an angle of  $90^\circ$  or  $\frac{\pi}{2}$  radians (see Arts. 622, 624).

**610. Graph of  $y = \sin nx$ , Where  $n$  Is Positive.**

Assume the graph of  $y = \sin x_1$ .

Let  $x_1 = nx$ .

Then  $y = \sin nx$ .

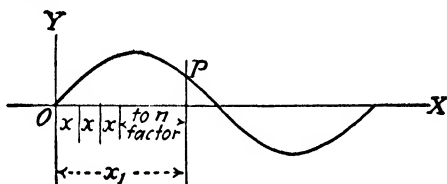

FIG. 268.

The coefficient of  $x$ ,  $n$ , shortens the abscissae of all points without changing the length of the ordinates. If  $n = 2$ , then  $x_1 = 2x$ , or  $x$  is one-half as long as  $x_1$ . Thus the abscissae are shortened in the ratio of  $1 : n$ .

In Fig. 269 are shown the graphs of  $y = \sin x$  and  $y = \sin 3x$ .

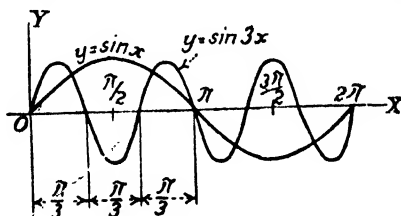

FIG. 269.

If  $n < 1$ , the curve would be a stretching of  $y = \sin x$  instead of a contraction. A similar result may be obtained by changing the scale of the abscissa of the standard graph of  $y = \sin x$  by a multiple of  $\frac{1}{n}$ .

611. In the equation,  $y = \sin 2x$ , consider the values of  $y$  as  $x$  increases from 0 to  $\frac{\pi}{2}$ , or from 0 to  $90^\circ$ .

$x \dots$	$0^\circ$	$9^\circ$	$18^\circ$	$27^\circ$	$36^\circ$	$45^\circ$	$54^\circ$	$63^\circ$	$72^\circ$	$81^\circ$	$90^\circ$
$2x \dots$	$0^\circ$	$18^\circ$	$36^\circ$	$54^\circ$	$72^\circ$	$90^\circ$	$108^\circ$	$126^\circ$	$144^\circ$	$162^\circ$	$180^\circ$
$y \dots$	0	.309	.588	.809	.951	1.00	-.951	-.809	-.588	-.309	0.00

Note that the two angles  $x$  which have the same sine or  $y$  values are complementary angles, as  $9^\circ$  and  $81^\circ$ ; that is, their sum always equals  $90^\circ$ . With the  $2x$  series, angles which have the same sine value are supplementary, as  $18^\circ$  and  $162^\circ$ .

From the above table it will be seen that the values of  $y$  form two waves, one positive and the other negative, while  $x$  varies from  $0^\circ$  to  $90^\circ$ .

### 612. Graph of $y = \sin (nx + B)$ .

Assume the graph of  $y = \sin nx_1$ , which can be constructed as shown in Art. 610.

$$\text{Let } x_1 = x + \frac{B}{n}.$$

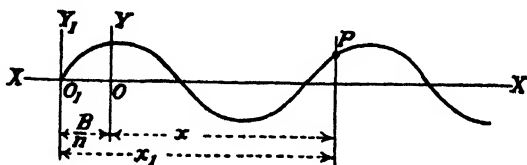

FIG. 270.

We have the graph of  $y = \sin nx_1$ , with origin at  $O_1$ , and we desire to shift to  $O$  and write an equation in  $x$  and  $y$  referred to the new axis.

$$\text{From the figure, } x_1 = x + \frac{B}{n}.$$

Substituting in  $y = \sin nx_1$ ,

$$y = \sin n\left(x + \frac{B}{n}\right) = \sin (nx + B).$$



This change from  $y = \sin nx$  to  $y = \sin (nx + B)$  simply means a translation of origin of  $y = \sin nx$ , a distance representing the angle  $\frac{B}{n}$  to make the graph become  $y = \sin (nx + B)$ .

By taking a standard graph of  $y = \sin x$ , changing the horizontal scale in the ratio of 1 to  $n$ , and then shifting the origin to  $(\frac{B}{n}, 0)$  on the original scale or to  $(B, 0)$  on the changed scale, the graph is  $y = \sin (nx + B)$  to the new origin.

If  $B$  is positive, shift the origin in the positive  $X$ -direction, and if  $B$  is negative, shift the origin in the negative  $X$ -direction.

**613. General Equation Graph,  $y = a \sin (nx + B)$ .** Since the ordinates, or  $y$ , are increased  $a$  times over the ordinates of  $y = \sin (nx + B)$ , which we discussed in the previous article, we can readily draw the graph of

$$y = a \sin (nx + B).$$

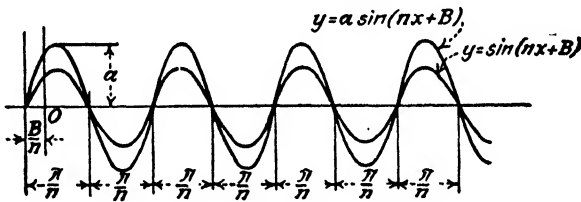

FIG. 271.

The constant  $a$  changes the height of the wave in the ratio of  $a$  to 1.

By taking a standard graph,  $y = \sin x$ , and changing the horizontal scale by the ratio of 1 :  $n$ , shifting the origin to  $(\frac{B}{n}, 0)$  measured on the original scale, or to  $(B, 0)$  measured on the changed scale, and multiplying each ordinate by  $a$ , or what amounts to the same thing, changing the  $y$ -scale so that each unit of the original scale represents  $a$  units on the new scale, we have the graph of  $y = a \sin (nx + B)$  to the new origin.

**614. Time Element in Sine Functions.**—If  $x$  and  $y$  are both measurements of distance or lengths, the sine graph may be used to represent the *form* or *shape* of waves generated by vibrating strings, etc.

If  $y$  denotes a linear distance and  $x$  the time in seconds, the sine graph may be used to represent periodic oscillations, such as the motion of springs, sound waves, or the projection of a rotating crank on a coordinate axis through the center of rotation.

Consider the angle  $\omega$  in radians as the unit angle which the generating line  $OP$  generates in 1 second, after starting from  $OA$  with a uniform motion.

After  $t$  seconds, the generating line  $OP$  has moved to  $OP'$  through the angle  $\theta$ .

Plot the time in seconds as abscissae and the sine function as ordinates.

Since  $OP$  rotates through  $\omega$  radians per second, the angle  $\theta$  is equal to  $\omega t$  radians after  $t$  seconds have elapsed. (The angle  $\theta$  increases at the rate of  $\omega$  radians per second.)

That is, since  $\omega$  represents angular velocity in radians per second, then the angle of rotation  $\theta$  after  $t$  seconds equals  $\omega t$ .

Our equation,  $y = r \sin \theta$ , then becomes  $y = OP \sin \omega t$ .

EXAMPLE.—A point  $P$  (Fig. 272) moves counterclockwise around a circular path of 4-inch radius. It starts at  $A$  and moves with a uniform angular velocity of 1 revolution in 10 seconds.

Plot a curve showing the distance of the projection of  $P$  on the vertical diameter from the center  $O$  at any time  $t$ , and write the equation of the motion.

SOLUTION.—If 1 revolution is made in 10 seconds, we will first divide the circumference into 10 equal parts so that each division will represent the distance traveled by  $P$  in a second. These divisions represent the angle  $\omega$  which is equal to  $\frac{2\pi}{10}$  radians, or .6283 radian, since the circumference equals  $2\pi$  or 6.283 radians, and each division is then .6283 radian.

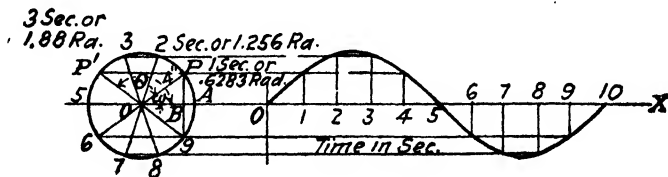

FIG. 272.

Take any convenient abscissa scale and plot 10 equal divisions as shown, and from the circular graph project the corresponding positions of the point  $P$  which give the required sine curve.

The angular velocity  $\omega$  equals .6283 radian per second,  $OP$  equals 4 inches, and  $PB$  equals  $OP \sin .6283t$ .

Therefore,

$$y = 4 \sin (.6283t).$$

The distance  $OP$  would represent the length of a crank or the position of maximum displacement of a spring vibrating above and below its normal position or the maximum vibration of a pendulum. It is the *amplitude* of the graph.

In case we are given the number  $n$  revolutions per second instead of angular velocity, the crank, or link motion, rotates through  $2\pi n$  radians per second, or

$$\omega = 2\pi n,$$

and our sine function is

$$y = OP \sin 2\pi nt.$$

615. To change a standard sine graph to a time sine graph, a short mathematical analysis will be given

Let  $y = r \sin \omega t.$

Then

$$\frac{y}{r} = \sin \omega t.$$

Let  $\lambda = \frac{y}{r}.$

Then

$$y = \lambda r.$$

Let  $x = \omega t.$

Then

$$t = \frac{x}{\omega}.$$

Figure 273 shows a standard sine graph with additional horizontal time scale and the amplitude vertical scale added which corresponds to the time scale.

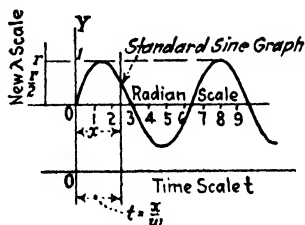

FIG. 273.

EXAMPLE.—Convert a standard sine graph into one to represent

$$y = .5 \sin 4t.$$

Then

$$\frac{y}{.5} = \lambda, \text{ or } y = .5\lambda.$$

Let  
Then

$$x = 4t.$$

$$t = \frac{x}{4}$$

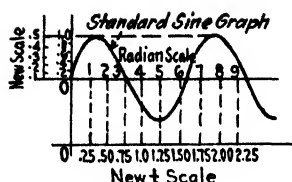

FIG. 274

By plotting a  $y$ -scale with units one-half as large as the  $\lambda$ -scale of the standard graph and a  $t$ -scale one-fourth of the radian scale as shown by Fig. 274, the graph of  $y = .5 \sin 4t$  is represented graphically.

If  $\omega$  is the angular velocity in radians per second, set the number of seconds for one complete revolution to  $2\pi$  on the standard scale. The subdivisions can then be made.

**616.** If  $n$  represents the number of revolutions of the crank in 1 minute,  $\omega$  becomes

$$\omega = \frac{2\pi n}{60},$$

and the equation becomes

$$y = OP \sin \frac{2\pi n}{60} t.$$

The angular velocity  $\omega$  determines the *period* of the graph. The period for uniform circular motion is the time required per revolution. Note that in Fig. 272 the curve has a period of 10 seconds, since 1 revolution is completed every 10 seconds and the graph is repeated every 10 seconds.

If  $\omega$  equals 1 radian per second, the period is  $2\pi$  seconds and  $y = \sin t$ .

For any value of  $\omega$ , the period is  $\frac{2\pi}{\omega}$ .

The *wave length* is the distance between similar points on the graph.

In cases of rapid rotation, it is often necessary to plot the time in tenths or even hundredths of a second.

**617.** Consider a point which makes 180 revolutions per minute. This is 3 rotations per second, or a frequency of 3. That is, the time required for a revolution, or period, is  $\frac{1}{3}$  second. That means that the angular velocity  $\omega$  is equal to

$$\frac{2\pi}{\frac{1}{3}} = 18.85 \text{ radians per second.}$$

The equation for a crank of 6-inch radius is then

$$y = 6 \sin (18.85t).$$

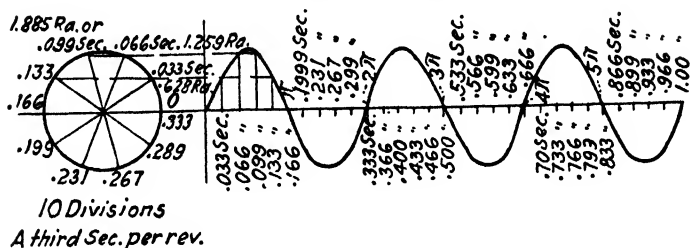

FIG. 275.

618. The frequency of uniform circular motion is the number of revolutions per second, or

$$\text{Frequency} = \frac{\omega}{2\pi} = \text{Number of periods per second}$$

The frequency is the reciprocal of the period, or

$$\text{Frequency} = \frac{1}{\text{Period}}$$

The frequency in Fig. 275 is 3, since 3 waves occur in a 1 second time interval, the point making 3 revolutions per second.

619. In case the angular measurement does not start from the horizontal  $X$ -axis but from some position different from the horizontal, either above or below it, then

$$y = r \sin (\omega t + c),$$

where  $c$  is the angle above or below the horizontal, measured from the positive end of the  $X$ -axis to the starting position;  $c$  is positive or negative according as it is measured in a counterclockwise or clockwise direction.

$$y = r \sin (\omega t + c).$$

$$\frac{y}{r} = \sin (\omega t + c).$$

Let

$$\gamma = \frac{y}{r}.$$

Then

$$y = \gamma r.$$

Let

$$X = \omega t + c.$$

Then

$$t = \frac{X}{\omega} - \frac{c}{\omega}.$$

The new scales are shown in the standard sine graph (Fig. 276).

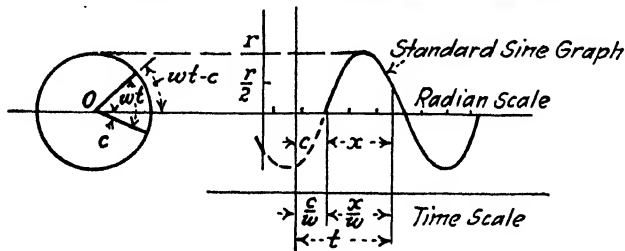

FIG. 276.

If  $c$  is given in angular measurement, locate the origin by measuring  $c$  direct on the radian scale. If  $c$  is given in time units or in terms of  $\omega$ , use time scale equal to time  $\frac{c}{\omega}$ .

EXAMPLE.—Plot  $y = r \sin(\omega t - 1.1)$  when the maximum amplitude equals .5 and  $\omega = 4$  radians per second.

Then  $y = .5 \sin(4t - 1.1)$ .

$$\frac{y}{.5} = \sin(4t - 1.1).$$

Let  $\gamma = \frac{y}{.5}$ .

Then  $y = .5\gamma$ .

Let  $X = 4t - 1.1$ .

Then  $t = \frac{X}{4} + \frac{1.1}{4}$ .

$$\frac{1.1}{4} = .275 \text{ second per radian,}$$

$$\text{or } \frac{4}{1.1} = 3.63 \text{ radians per second.}$$

Lay off to scale 1 second equal to 3.63 radians from the new origin and then subdivide into fractions of a second as shown by Fig. 277 and 278.

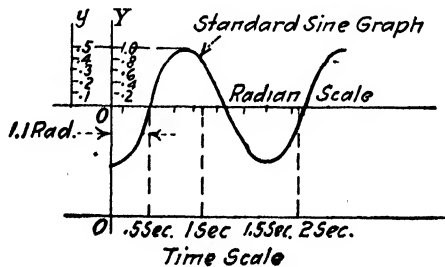

FIG. 277.

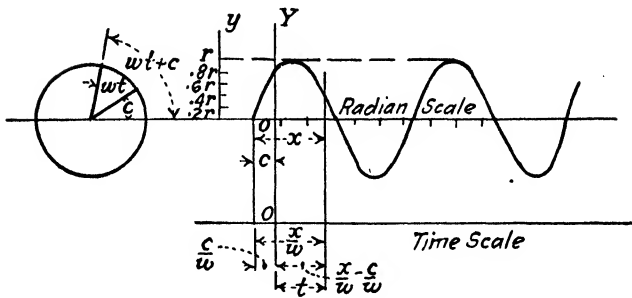

FIG. 278.

The constant angle  $c$  merely shifts the curve along the  $X$ -axis, or  $t$ -axis in this case, and does not change the form of the graph.

In the case of a crank motion,  $a$  represents the length of the crank.

EXAMPLE.—A crank  $OP$  (Fig. 279) of 24-inch length starts from a position making an angle of  $30^\circ$ , or  $\frac{2\pi}{12} = .5236$  radian, with the horizontal line. Then  $t$  equals zero at this starting point. It rotates at the rate of 2 revolutions per second.

Since the time of each revolution is  $\frac{1}{2}$  second, and the circumference has 12 divisions, each division is .0417 second apart.

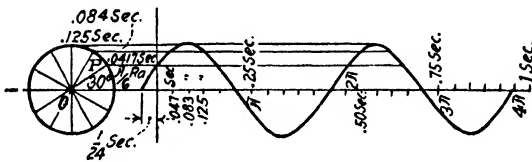

FIG. 279.

The crank makes 2 revolutions per second, or  $2 \times 2\pi$  radians per second; therefore,  $\omega = 4\pi$ .

$30^\circ = \frac{\pi}{6}$  radians, and from Art. 613, the shifting of the origin is  $\frac{B}{n}$ ,

which in this case is  $\frac{\frac{\pi}{6}}{\frac{4\pi}{1}} = \frac{1}{24} = .0417$  second, which checks with the division of seconds.

The equation of the above motion is

$$y = 24 \sin \left( 4\pi t + \frac{\pi}{6} \right).$$

**620. An Alternating Current.**—An alternating current rises to a positive maximum intensity, then decreases to zero and reverses, then decreases to a minimum negative intensity, and then increases to zero, completing a cycle. This varying intensity is represented by a sine function, as

$$i = 10 \sin (200t),$$

where  $t$  is the elapsed time in seconds and  $200t$  is the number of radians in the *phase angle*.

Since the graph is a sine curve and the greatest value of the sine is unity, the maximum  $i$  is 10 units in this case and occurs at the point where the ordinates of the curve begin to decrease. There are several oscillations per second. There is a complete oscillation of  $i$  when the angle  $200t$  reaches the value  $2\pi$ , or

$$200t = 2\pi, t = .01\pi = .0314+.$$

That is, a complete oscillation takes  $\frac{314}{10,000}$  or  $\frac{1}{30}$  second

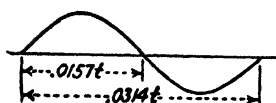

FIG. 280.

(approximately) and the current alternates approximately sixty times per second.

The distance between the points where the horizontal axis is intersected by the curve gives the time required for each alternation. This is evidently one-half the time required to complete a cycle. In this case the time required for each alternation is .0157 second.

**621. Functions of the Form,  $x = a \sin (ny + B)$ .**—These functions are similar to  $y = a \sin (nx + B)$ , except that, since the variables are interchanged, the graphs have their axes interchanged. The equations,  $x = \sin y$ ,  $x = \sin (y + B)$ , and  $x = \sin ny$ , follow the same principles as

$$\begin{aligned} y &= \sin x, \\ y &= \sin (x + B), \text{ and} \\ y &= \sin nx. \end{aligned}$$



Since  $x$  and  $y$  are interchanged, the graphs are constructed on the  $Y$ -axis instead of on the  $X$ -axis, as shown in Fig. 281, where the graph of the function,

$$x = a \sin (ny + .B),$$

is shown.

**622. Graphs of Cosine Functions.**— Consider the function,

$$y = \cos x,$$

and let  $x$  equal the angle in radians.

Using rectangular coordinates with  $x$ , the abscissa of any point, being the number of radians in the angle represented by the point, and  $y$ , the ordinate at that point, representing the cosine of the angle, plot the curve.

The graph cuts the  $X$ -axis when

$$x = \frac{\pi}{2}, \frac{3\pi}{2}, \frac{5\pi}{2}, \dots (k - \frac{1}{2})\pi, \text{ and}$$

$$x = -\frac{\pi}{2}, -\frac{3\pi}{2}, -\frac{5\pi}{2}, \dots -(k - \frac{1}{2})\pi, \text{ where}$$

$k$  is any positive or negative integer or zero.

$$y = 1 \text{ when } x = 0.$$

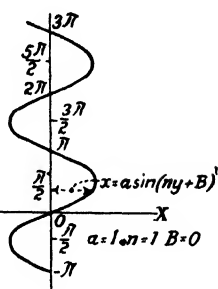

FIG. 281.

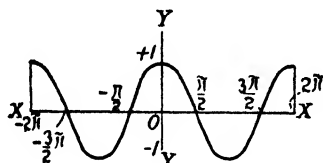

FIG. 282.

**623. Construction of Cosine Graphs.**—Since

$$\cos x = \sin (90^\circ + x),$$

the cosine graph is the sine graph translated along the  $X$ -axis a distance representing  $90^\circ$  or  $\frac{\pi}{2}$  radians.

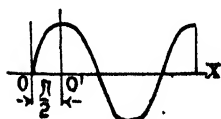

FIG. 283.

In Fig. 283,  $O$  is the origin for the sine graph and  $O'$  is the origin for the cosine curve.

Since the starting points of the two curves are  $90^\circ$  apart but the curves are otherwise

the same, we can construct the cosine graph in the same manner as the sine graph, except that for the cosine we start  $90^\circ$  ahead of the sine angles, thus:

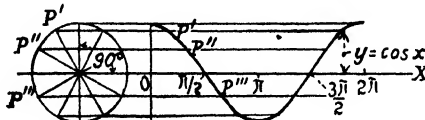

FIG. 284.

624. Graphs of  $y = \cos(x + B)$ ,

$$y = \cos 2x,$$

$$y = \cos nx,$$

$$y = \cos(nx + B), \text{ and}$$

$$y = a \cos(nx + B)$$

all follow the same laws as the sine function for these angles and may be developed from  $y = \cos x$  in the same manner as was done in the case of the sine function.

The graph is a sine function or a cosine function depending simply upon where the starting point is made, or in other words, upon the location of the origin.

In the case of the cosine function, too, the interchange of  $x$  and  $y$  transfers the graph from the  $X$ -axis to the  $Y$ -axis.

**625. Compound Periodic Oscillation or Wave Graphs.**—The general equations,  $y = a \sin(nx + B)$  and  $y = a \cos(nx + B)$ , represent the simplest form of periodic motion. More complex periodic motions are represented by the more general expression,

$$y = a_1 \sin(nx + B_1) + a_2 \sin(2nx + B_2) + \dots \\ + b_1 \cos(nx + B_1) + b_2 \cos(2nx + B_2) + \dots$$

The note of a musical instrument, as a flute or violin, consists of the fundamental tone represented by

$$y = a_1 \sin(nx + B_1),$$

and the overtones or harmonics represented by

$$y = a_2 \sin(2nx + B_2),$$

$$y = a_3 \sin(3nx + B_3), \text{ etc.}$$

In plotting an equation of this kind, it is more convenient to plot each sine function separately and add the corresponding ordinates or  $y$  values to get the new graph, thus,

$$y = 2 \sin x + \frac{1}{2} \sin 3x.$$

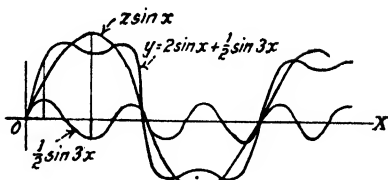

FIG. 285.

**626. Damped Oscillations.**—Many laws of nature follow a sine or cosine oscillation with a decreasing amplitude. That is, the value  $a$  is a decreasing value and follows an exponential law. It is usually represented by  $ae^{-bx}$ . The sine equation then takes the form,

$$y = ae^{-bx} \sin (nx + B).$$

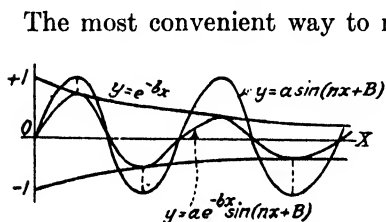

FIG. 286.

The most convenient way to make this graph is to plot  $e^{-bx}$  and  $a \sin (nx + B)$  separately, and multiply the respective ordinates, or  $y$  values, together for the new  $y$  value.

The term  $b$  in the equation may be considered as a measure of the resistance, or retarding effect, and is called

the logarithmic decrement of the oscillation.

**627. Boundary Curves.**—In plotting the locus of an equation, such as

$$y = e^x \sin x, \text{ or } S = t^2 \cos \frac{\pi t}{4},$$

where one of the factors of the product is a sine or a cosine, a quick way to plot the locus is to consider the curve represented by the other factor as a boundary curve (see Fig. 287a).

Consider the equation,

$$y = e^{-ix} \sin \frac{\pi x}{2}. \tag{1}$$

Since the numerical value of the sine never exceeds 1, the values of  $y$  in (1) will not exceed the numerical value of the first factor,  $e^{-ix}$ .

The extreme values of  $\sin \frac{1}{2}\pi x$  are  $+1$  and  $-1$ . Therefore,  $y$  has the extreme values,  $e^{-ix}$  and  $-e^{-ix}$ , and the curves,  $y = e^{-ix}$  and  $y = -e^{-ix}$ , can be used as the boundary curves of  $y$  in (1).

Another helpful comparison is that when  $\sin \frac{1}{2}\pi x = 0$ ,  $y = 0$ . Hence, the locus of (1) meets the X-axis at the same points as the sine curve,  $y = \sin \frac{1}{2}\pi x$ .

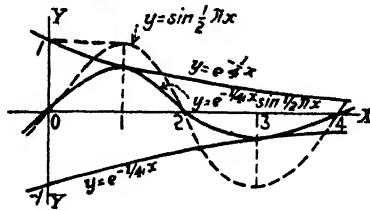

FIG. 287a.

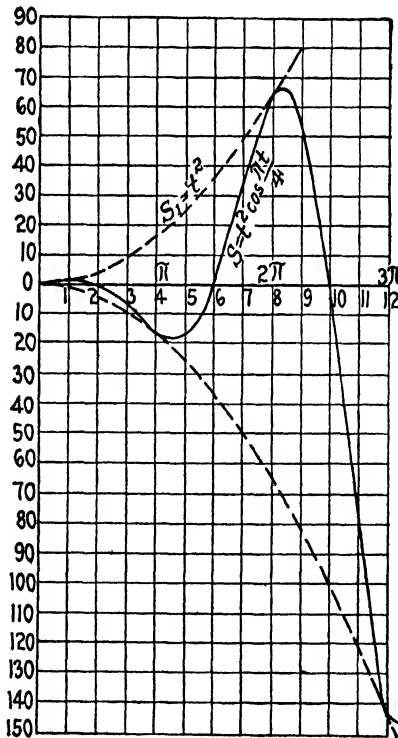

FIG. 287b.

Another aid to construction is that the required curve touches the exponential curves when the sine curve reaches its maximum or minimum values, or when  $\sin \frac{1}{2}\pi x$  is 1 or  $-1$ .

The locus of (1) crosses the  $X$ -axis at  $x = 0, \pm 2, \pm 4, \pm 6,$  etc., and touches the boundary curve at  $x = \pm 1, \pm 3, \pm 5,$  etc.

Another example of the boundary curve for  $S = t^2 \cos \frac{\pi t}{4}$  is given in Fig. 287*b*.

The curve crosses the  $X$ -axis when  $\cos \frac{\pi t}{4} = 0$ , and is tangent to the boundary curves when  $\cos \frac{\pi t}{4} = 1$ , or  $\cos \frac{\pi t}{4} = -1$ .

**628. Addition of Ordinates.**—When the equation consists of two or more members, as in

$$y = 2 \sin \frac{\pi x}{4} + \frac{1}{2}x,$$

it is convenient to plot auxiliary curves to the same scale, one below the other, as

$$y_1 = 2 \sin \frac{\pi x}{4}.$$

$$y_2 = \frac{1}{2}x.$$

Add the corresponding ordinates to make the sum curve for

$$y = y_1 + y_2.$$

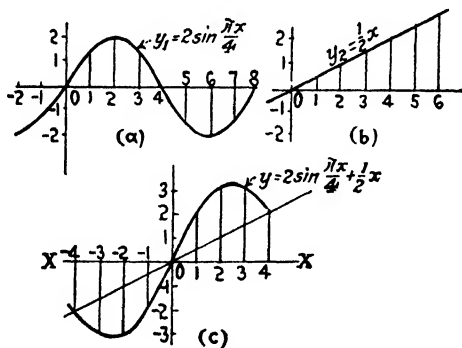

FIG. 288.

**629. The Inverse Trigonometric Graphs.**—The equation,  $y = \sin x$ , can also be written in the form,  $x = \sin^{-1} y$ , or  $x = \text{arc sin } y$ , meaning the angle  $x$  whose sine is  $y$ .

It is, therefore, evident that the graphs of  $y = \sin x$  and  $x = \sin^{-1} y$  are identical. In the first case,  $y$  is a function of  $x$ , and in the latter case,  $x$  is a function of  $y$ .

If, however, we have  $y = \sin^{-1} x$ , which reduces to  $x = \sin y$ , we have an interchange of  $x$  and  $y$  from  $y = \sin x$ , and our graph would be traced on the  $Y$ -axis instead of on the  $X$ -axis.

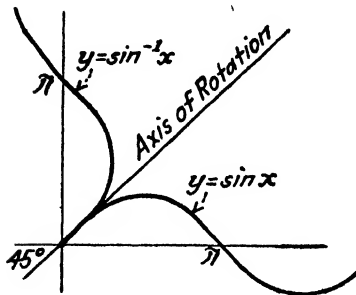

FIG. 289.

$\cos(-x) = \cos x$ , and, therefore, the graphs of  $y = \cos x$  and  $y = \cos(-x)$  are identical. This follows since changing the sign of  $x$  reflects across the  $Y$ -axis (Art. 602), and since the cosine curve is symmetrical with respect to the  $Y$ -axis, changing the sign of  $x$  does nothing.

This rule also applies to the cosine, tangent, secant, etc.

Another method is to consider the graphs as being drawn on transparent paper and rotated about an axis which passes through the origin and which has an angle of  $45^\circ$  with the  $X$ -axis (see Art. 250).

### 630. Comparison of Sine and Cosine Graphs.—

Note that  $y =$

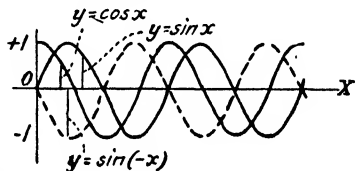

FIG. 290.

**631. Graph of  $y = \tan x$ .**—The tangent function varies from 0 to  $\infty$  when the angle varies from  $0^\circ$  to  $90^\circ$  or  $\frac{\pi}{2}$ , and from  $-\infty$  to 0 when the angle varies from  $90^\circ$  to  $180^\circ$ . When the angle increases from  $180^\circ$  to  $270^\circ$ , the tangent varies from 0 to  $\infty$ , and when the angle increases from  $270^\circ$  to  $360^\circ$ , the tangent varies from  $-\infty$  to 0.

**632. Construction of  $y = \tan x$  Graph.**—Referring to Art. 599, where the relation of the trigonometric functions was shown graphically, the tangent was shown as in (a), (b), (c) and (d) Fig. 292.

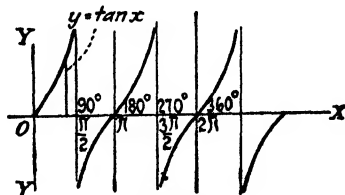

FIG. 291.

By plotting the angle  $x$  as abscissae and  $y$  or  $\tan x$  as ordinates, the graph is readily constructed.

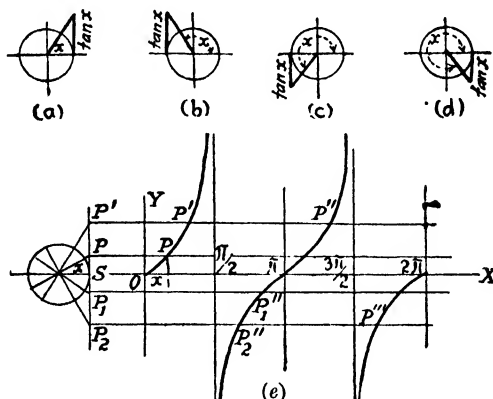

FIG. 292.

Since  $\tan x$  is positive in the first and third quadrants and negative in the second and fourth quadrants, the positive tangents  $PS$  can be plotted for angles in the first and third, and  $SP_1$  and  $SP_2$  for tangents in the second and fourth quadrants.

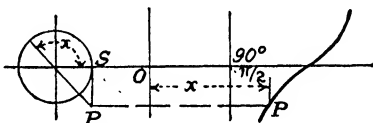

FIG. 293.

An example of an angle in the second quadrant is shown in Fig. 293.

633. Graphs of  $y = \tan(x + B)$ ,  
 $y = \tan nx$ ,  
 $y = \tan(nx + B)$ , and  
 $y = a \tan(nx + B)$

all follow the same laws as the sine functions (Art. 607 *et seq.*).

The general form of  $y = a \tan(nx + B)$  is shown in Fig. 294 below.

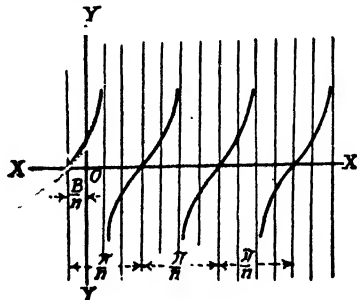

FIG. 294.

In this case, the ordinates are increased  $a$  times over the ordinates of  $y = \tan (nx + B)$ , which was discussed in the previous article. By taking the standard graph,  $y = \tan x$ , and changing the horizontal scale in the ratio of  $n:1$ , shifting the origin to  $(\frac{B}{n}, 0)$  and multiplying the ordinates by  $a$ , we obtain the graph of  $y = a \tan (nx + B)$ , referred to the new origin.

EXAMPLE.—Construct the graph of  $\tan (2\theta + 45^\circ)$ .

The period of the function  $y = \tan nx$  is  $\frac{\pi}{n}$ .

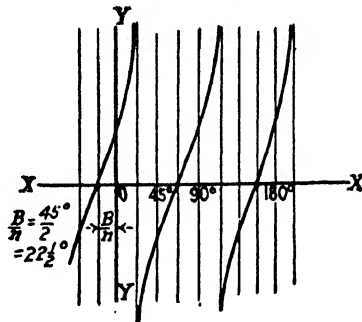

FIG. 295.

634. Comparison of Tangent Graphs.—The following figure shows several tangent graphs for comparison:

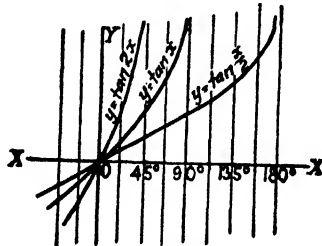

FIG. 296.

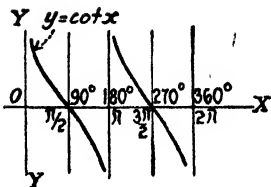

FIG. 297.

635. Graph of the Function,  $a \cot (nx + B)$ .—This function is seldom used and we will confine the discussion to the  $y = \cot x$  function and to the general form,  $y = a \cot (nx + B)$ .

The ordinates are increased  $a$  times over the ordinates of  $y = \cot (nx + B)$ ,



which can be made from the graph of  $y = \cot x$  in a manner similar to that used for the construction of the graph of  $y = \tan (nx + B)$  in Art. 633. By constructing a standard graph of  $y = \cot x$ , changing the horizontal scale in the ratio of  $n:1$ , then shifting the origin to  $(\frac{B}{n}, 0)$  and multi-

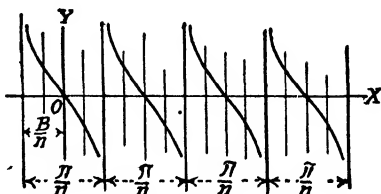

FIG. 298.

plying the ordinates by  $a$ , we obtain the graph of  $y = a \cot (nx + B)$ , referred to the new origin.

**636. Construction of  $y = \cot x$  Graph.**—Since  $\cot x = \tan (\frac{\pi}{2} - x)$ , we can draw the cotangent graph similar to the tangent graph by starting  $90^\circ$  from the tangent starting point and rotate in a negative direction, since  $x$  is negative.

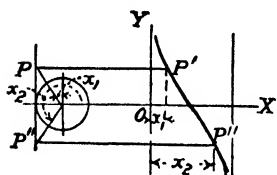

FIG. 299.

**637. Graphs of  $y = \sec x$  and  $y = \csc x$ .**—Since the radius of the circle

is unity, the radius vector  $OS$  or  $OS_1$  is the measure of the secant. By rotating into the vertical and then projecting across horizontally, the value of  $y$  is found for each value of  $x$ .

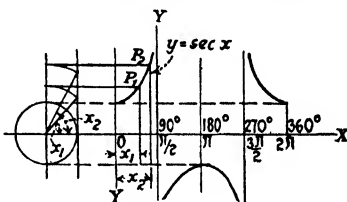

FIG. 300.

The graph of the cosecant is similar to that of the secant except that the starting point for  $x$  on the circle is advanced  $90^\circ$ .

It is readily seen that by translating the origin of the cosecant graph  $90^\circ$  we have the secant curve. In other words,

$$\sec x = \csc (90^\circ + x).$$

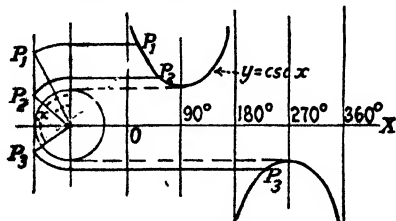

FIG. 301.

## CHAPTER XXV

### TRIGONOMETRIC SOLUTION OF TRIANGLES

**638. Solution of Right Triangles.**—In the solution of right triangles, the trigonometric functions and the relations,

$$\angle A + \angle B = 90^\circ \quad \text{and} \quad c^2 = a^2 + b^2,$$

are the means used to find the unknown parts.

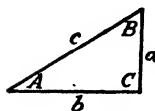

Two parts in addition to the right angle must be known, with one of these parts a side. The trigonometric function selected should involve two of the given parts and one unknown part.

FIG. 302.

**EXAMPLE.**—Given  $A = 32^\circ 16'$ ,  $a = 200$ . To find  $b$ ,  $c$ , and  $B$ .

$$B = 90^\circ - A = 90^\circ - 32^\circ 16' = 57^\circ 44'.$$

$$\sin A = \frac{a}{c} \quad \therefore c = \frac{a}{\sin A} \quad \cot A = \frac{b}{a} \quad \therefore b = a \cot A.$$

$$\sin 32^\circ 16' = .53386.$$

$$\cot 32^\circ 16' = 1.5839.$$

Then

$$c = \frac{200}{.53386} = 374.6.$$

Then

$$b = 200 \times 1.5839 = 316.78.$$

**EXAMPLE 2.**—Given  $a = 52.6$ ,  $b = 65.4$ .

$$\tan A = \frac{a}{b} = \frac{52.6}{65.4} = .8043.$$

$$c = \sqrt{a^2 + b^2}.$$

From table,  $A = 38^\circ 49'$ .

$$= \sqrt{2767 + 4277}.$$

Then  $B = 90^\circ - 38^\circ 49' = 51^\circ 11'$ .

$$= 83.92.$$

**EXAMPLE 3.**—Given  $A = 59^\circ 58'$ ,  $b = 412$ . To find  $a$ ,  $c$ , and  $B$ .

$$\tan A = \frac{a}{b} \quad \therefore a = b \tan A.$$

$$\cos A = \frac{b}{c} \quad \therefore c = \frac{b}{\cos A}.$$

$$\tan 59^\circ 58' = 1.7297.$$

$$a = 412 \times 1.7297 = 712.64.$$

$$c = \frac{412}{.50050} = 823.11.$$

$$B = 90^\circ - A = 90^\circ - 59^\circ 58' = 30^\circ 2'.$$

**EXAMPLE 4.**—Given  $B = 70^\circ 10'$ ,  $c = 35.2$ .

$$\sin B = \frac{b}{c} \quad \therefore b = c \sin B.$$

$$\cos B = \frac{a}{c} \quad \therefore a = c \cos B.$$

$$\sin 70^\circ 10' = .94068.$$

$$\cos 70^\circ 10' = .33929.$$

$$b = 35.2 \times .94068 = 33.112.$$

$$a = 35.2 \times .33929 = 11.94.$$

$$A = 90^\circ - B = 90^\circ - 70^\circ 10' = 19^\circ 50',$$

**639.** The solution of right triangles by logarithms usually results in accuracy and speed.

**EXAMPLE 1.**—Given  $a = 23.47$ ,  $B = 26^\circ 15.2'$ . To find  $A$ ,  $b$ , and  $c$ .

$\frac{b}{a} = \tan B. \quad \therefore b = a \tan B.$ $\log \tan B = 9.64576 - 10$ $\log a = 1.37051$ <hr style="width: 80%; margin: 0 auto;"/> $\log b = 1.01627$ $b = 10.38.$	$\frac{a}{c} = \cos B. \quad \therefore c = \frac{a}{\cos B}$ $\log \cos B = 9.95272 - 10$ $\log a = 1.37051$ <hr style="width: 80%; margin: 0 auto;"/> $\log c = 1.41779$ $c = 26.17.$
$A = 90^\circ - B = 90^\circ - 26^\circ 15.2' = 33^\circ 44.8'.$	

**EXAMPLE 2.**—Given  $B = 58^\circ 39'$ ,  $c = 35.73$ . To find  $A$ ,  $a$ , and  $b$ .

$\frac{b}{c} = \sin B. \quad \therefore b = c \sin B.$ $\log \sin B = 9.93146 - 10$ $\log c = 1.55303$ <hr style="width: 80%; margin: 0 auto;"/> $\log b = 1.48449$ $b = 30.51.$	$\frac{a}{c} = \cos B. \quad \therefore a = c \cos B.$ $\log \cos B = 9.71622 - 10$ $\log c = 1.55303$ <hr style="width: 80%; margin: 0 auto;"/> $\log a = 1.26925$ $a = 18.59.$
$A = 90^\circ - B = 90^\circ - 58^\circ 39' = 31^\circ 21'.$	

**EXAMPLE 3.**—Given  $a = 50$ ,  $b = 60$ . To find  $A$ ,  $B$ , and  $c$ .

$\frac{a}{b} = \tan A. \quad \therefore \tan A = \frac{5}{6}.$ $\log a = 11.6990 - 10$ $\log b = 1.7782$ <hr style="width: 80%; margin: 0 auto;"/> $\log \tan A = 9.9208 - 10$ $A = 39^\circ 48'.$	$\frac{a}{c} = \sin A. \quad \therefore c = \frac{a}{\sin A}.$ $\log a = 11.6990 - 10$ $\log \sin A = 9.8063 - 10$ <hr style="width: 80%; margin: 0 auto;"/> $\log c = 1.8927$ $c = 78.1.$
--	--

**640. Another Scheme for the Use of Logs in Solving Right Triangles.**—Suppose that we wish to find one leg  $a$ , of a right triangle when we have given the hypotenuse and the other leg  $c$  (Fig. 303).

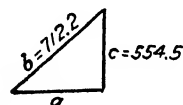

FIG. 303.

Since

$$a = \sqrt{(712.2)^2 - (554.5)^2},$$

$a$  may be computed, but in this form it is not very convenient to use logs. But from algebra, we have

$$\begin{aligned} b^2 - c^2 &= (b + c)(b - c). \\ b + c &= 1266.7. \\ b - c &= 157.7. \end{aligned}$$

Therefore,

$$a = \sqrt{(1266.7)(157.7)},$$

from which the value of  $a$  may be very easily computed by logs.

### OBLIQUE TRIANGLES

**641. The Sine Law.**—In any triangle, the sides are proportional to the sines of the opposite angles.

$$\frac{a}{b} = \frac{\sin A}{\sin B}, \frac{a}{c} = \frac{\sin A}{\sin C}, \text{ etc., or}$$

$$\frac{a}{\sin A} = \frac{b}{\sin B} = \frac{c}{\sin C} \quad [90].$$

**642. The Cosine Law.**—In every triangle, the square of a side equals the sum of the squares of the other sides minus twice the product of these sides by the cosine of their included angle.

$$[309] \quad \begin{aligned} a^2 &= b^2 + c^2 - 2bc \cos A, \\ b^2 &= a^2 + c^2 - 2ac \cos B, \\ c^2 &= a^2 + b^2 - 2ab \cos C, \end{aligned}$$

or

$$[310] \quad \begin{aligned} \cos A &= \frac{b^2 + c^2 - a^2}{2bc}, \\ \cos B &= \frac{c^2 + a^2 - b^2}{2ac}, \\ \cos C &= \frac{a^2 + b^2 - c^2}{2ab}. \end{aligned}$$

**643. Solution of Oblique Triangles.**—In solving oblique triangles, the two most important laws to know are the law of sines (Art. 641) and the law of cosines (Art. 642).

It is advisable first to make a drawing of the triangle to scale and measure the sides and angles. For many engineering purposes this will be sufficiently accurate. For more accurate results, use a six-place log table.

In many cases, the oblique triangle can be conveniently divided into two right triangles and solved by the use of the right triangle formula,  $c^2 = a^2 + b^2$ , and the standard trigonometric functions.

**EXAMPLE.**—Given three sides of an oblique triangle, to find the angles.

$$\begin{aligned} h^2 &= 15^2 - x^2. \\ h^2 &= 10^2 - (20 - x)^2. \end{aligned}$$

Then

$$225 - x^2 = 100 - 400 + 40x - x^2.$$

$$40x = 525.$$

$$x = 13.125.$$

$$\cos A = \frac{x}{15} = \frac{13.125}{15} = .875.$$

$$\therefore A = 28^\circ 57'.$$

$$\cos C = \frac{20 - x}{10} = \frac{6.875}{10} = .6875.$$

$$\therefore C = 46^\circ 34'.$$

$$B = 180^\circ - (A + C) = 180^\circ - 75^\circ 31' = 104^\circ 29'.$$

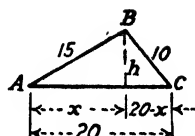

FIG. 304.

Oblique triangles have six elements, three sides and three angles. If any three elements are given, at least one being a side, the remaining three may be determined. The possible arrangements of these elements and their solutions are divided into the four cases which follow.

**644. Case 1. Given Two Angles and One Side.**

*Condition.*—The sum of the angles must be less than  $180^\circ$ .

First draw the triangle.

Use the law of sines.

GIVEN	SOUGHT	FORMULA
$A, B, a$	$b$	$b = \frac{a \sin B}{\sin A}$
	$C$	$C = 180^\circ - (A + B)$
	$c$	$c = \frac{a \sin C}{\sin A} = \frac{a \sin (A + B)}{\sin A}$



FIG. 305.

To check use,  $c \cos B + b \cos C = a$ .

$$\text{Area} = \frac{1}{2} ab \sin C = \frac{a^2 \sin B \sin C}{2 \sin A}.$$

*Alternative.*—Drop a perpendicular from the vertex to the base and solve as two right triangles. The perpendicular should not be dropped to the given side  $a$  as a base.

**EXAMPLE.** Case 1.—Given  $b = 6.362$ ,  $A = 76^\circ 13'$ ,  $C = 35^\circ 17'$ .

To find  $a$ ,  $c$ , and  $B$ .

$$B = 180^\circ - (A + C) = 180^\circ - 111^\circ 30' = 68^\circ 30'.$$

$$a = \frac{b \sin A}{\sin B}.$$

$$c = \frac{b \sin C}{\sin B}.$$

$\log b = .80359$ $\log \sin A = 9.98731 - 10$ <hr style="width: 80%; margin: auto;"/> $10.79090 - 10$ $\log \sin B = 9.96868 - 10$ <hr style="width: 80%; margin: auto;"/> $\log a = .82222$ $a = 6.641.$	$\log b = .80359$ $\log \sin C = 9.76164 - 10$ <hr style="width: 80%; margin: auto;"/> $10.56523 - 10$ $\log \sin B = 9.96868 - 10$ <hr style="width: 80%; margin: auto;"/> $\log c = .59655$ $c = 3.95.$
---	--

**645. Case 2. Given Two Sides and the Included Angle.**

*Condition.*—Suppose  $a > b$ .

Use the law of sines and the law of cosines.

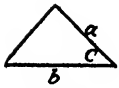
	GIVEN	SOUGHT	FORMULA
	$a, b, C$	$c$	$c = \sqrt{a^2 + b^2 - 2ab \cos C}$
	Find smaller	$B$	$\sin B = \frac{b \sin C}{c}$
	$\angle B$ first	$A$	$A = 180^\circ - (B + C)$
FIG. 306.	To check use, $a \cos B + b \cos A = c$ .		

*Alternative.*—Drop a perpendicular from the vertex to the base and solve as two right triangles. The perpendicular must not be dropped from the given angle  $C$ .

**EXAMPLE.** Case 2.—Given  $a = 20.63, b = 12.55, C = 27^\circ 24'$ .

$$c = \sqrt{a^2 + b^2 - 2ab \cos C}.$$

$$= \sqrt{(20.63)^2 + (12.55)^2 - 2 \times 20.63 \times 12.55 \times .8878}.$$

$$= \sqrt{425.6 + 157.5 - 459.7} = 11.09.$$

$$\sin B = \frac{b \sin C}{c}.$$

$$\log b = 1.09864$$

$$\log \sin C = 9.66295 - 10$$

---

$$10.76159 - 10$$

$$\log c = 1.04493$$

---

$$\log \sin B = 9.71588 - 10$$

$$B = 31^\circ 20'.$$

$$A = 180^\circ - (31^\circ 20' + 27^\circ 24') = 121^\circ 16'.$$

**646. Case 3. Given the Three Sides.**

*Condition.*—The longest side must be less than the sum of the other two sides.

First draw the triangle.

Use the law of sines and the law of cosines.

GIVEN	SOUGHT	FORMULA
$a, b, c$	$A$	$\cos A = \frac{b^2 + c^2 - a^2}{2bc}$
	$B$	$\sin B = \frac{b \sin A}{a}$
	$C$	$\sin C = \frac{c \sin A}{a}$

To check use,  $A + B + C = 180^\circ$ .

If greater accuracy is required,

$$s = \frac{a + b + c}{2}.$$

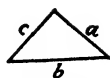

FIG. 307.

GIVEN	SOUGHT	IF HALF THE ANGLE IS NEAR $0^\circ$ , USE FORMULA	IF HALF THE ANGLE IS NEAR $90^\circ$ , USE FORMULA
		$a, b, c$	$A$
		or	
		$\tan \frac{1}{2}A = \sqrt{\frac{(s-b)(s-c)}{s(s-a)}}$	
	$B$	$\sin \frac{1}{2}B = \sqrt{\frac{(s-a)(s-c)}{ac}}$	$\cos \frac{1}{2}B = \sqrt{\frac{s(s-b)}{ac}}$
		or	
		$\tan \frac{1}{2}B = \sqrt{\frac{(s-a)(s-c)}{s(s-b)}}$	
	$C$	$\sin \frac{1}{2}C = \sqrt{\frac{(s-a)(s-b)}{ab}}$	$\cos \frac{1}{2}C = \sqrt{\frac{s(s-c)}{ab}}$
		or	
		$\tan \frac{1}{2}C = \sqrt{\frac{(s-a)(s-b)}{s(s-c)}}$	

To check use,  $A + B + C = 180^\circ$ .

$$\text{Area} = \sqrt{s(s-a)(s-b)(s-c)}.$$

EXAMPLE. Case 3.—Given  $a = 10, b = 12, c = 14$ .

To find  $A, B,$  and  $C$ .

$$\cos A = \frac{b^2 + c^2 - a^2}{2bc} = \frac{144 + 196 - 100}{336} = .714.$$

$$A = 44^\circ 26'.$$

$$\sin B = \frac{b \sin A}{a} = \frac{12 \times .70008}{10} = .84010.$$

$$B = 57^\circ 8'.$$

$$\sin C = \frac{c \sin A}{a} = \frac{14 \times .70008}{10} = .98010.$$

$$C = 78^\circ 33'.$$

To check use,  $A + B + C = 180^\circ 3'$ .

**647. Case 4. Given Two Sides and the Angle Opposite One of Them.**—This is known as the ambiguous case because, if certain relations exist between the given elements, it may be impossible to construct the triangle, or else one or two triangles may be made from the given elements.

Draw the triangle as the first test. If the triangle seems possible, apply the following test, using the law of sines.

Given  $A$ ,  $a$ , and  $b$ .

$$\sin B = \frac{b \sin A}{a}$$

If  $\sin B > 1$ , there is no solution.

If  $\sin B = 1$ , then  $B = 90^\circ$  and the triangle is a right triangle.

If  $\sin B < 1$ , there may be two solutions, one with  $B_1$ , an acute angle and the other with  $B_2$ , an obtuse angle.

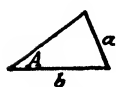

FIG. 308.

$B_1 + A$  will always be less than  $180^\circ$ .

$B_2 + A$  may or may not be less than  $180^\circ$  and

will yield a solution only when less than  $180^\circ$ .

GIVEN	SOUGHT	FORMULA
$a, b, A$	$B$	$\sin B = \frac{b \sin A}{a}$
	$C$	$C = 180^\circ - (A + B)$
	$c$	$c = \frac{a \sin C}{\sin A} = \frac{b \sin C}{\sin B}$
		$= \sqrt{a^2 + b^2 - 2ab \cos C}$

To check use,  $a \cos B + b \cos A = c$ .

Area =  $\frac{1}{2}ab \sin C$ .

**EXAMPLE 1.** Case 4.—Given  $A = 43^\circ 26'$ ,  $a = 4.75$ ,  $b = 18.6$ .

To find  $c$ ,  $B$ ,  $C$ .

$$\begin{aligned} \sin B &= \frac{b \sin A}{a} \\ \log b &= 1.26951 \\ \log \sin A &= 9.83728 - 10 \\ \hline &1.10679 \\ \log a &= .67669 \\ \hline \log \sin B &= .43010 \end{aligned}$$

This shows that  $\sin B > 1$ . Therefore, there is no solution.



**EXAMPLE 2.** Case 4.—Given  $A = 43^{\circ}26'$ ,  $a = 14.75$ ,  $b = 18.6$ .  
To find  $c$ ,  $B$ , and  $C$ .

$$\sin B = \frac{b \sin A}{a}$$

$$\begin{array}{r} \log b = 1.26951 \\ \log \sin A = 9.83728 - 10 \\ \hline 11.10679 - 10 \\ \log a = 1.16879 \\ \hline \log \sin B = 9.93800 - 10. \end{array}$$

This shows that  $\sin B < 1$  and there may be two solutions of the triangle; we will solve for  $B = 60^{\circ}6'$  and  $119^{\circ}54'$  which is the supplement of  $60^{\circ}6'$ .

$B = 60^{\circ}6'$ $C = 180^{\circ} - (A + B) =$ $180^{\circ} - (43^{\circ}26' + 60^{\circ}6') =$ $76^{\circ}28'.$	$B' = 119^{\circ}54'.$ $C' = 180^{\circ} - (43^{\circ}26' + 119^{\circ}54').$ $= 16^{\circ}40'.$
---	--

$c = \frac{a \sin C}{\sin A}.$ $\log a = 1.16879$ $\log \sin C = 9.98777 - 10$ $\hline 11.15656 - 10$ $\log \sin A = 9.83728 - 10$ $\hline \log c = 1.31928$ $c = 20.86.$	$c' = \frac{a \sin C'}{\sin A}.$ $\log a = 1.16879$ $\log \sin C' = 9.45758 - 10$ $\hline 10.62637 - 10$ $\log \sin A = 9.83728 - 10$ $\hline \log c = .78909$ $c = 6.153.$
---	---

**648. A simple rule to memorize which tells which law to use in solving any given triangle is:** Use the law of cosines if given the three sides or two sides and their included angle and the law of sines in all other cases. Both of these laws apply to obtuse angles.

**649. Solving Triangles.**—In solving triangles, it is the best practice to find each element from the given elements rather than to determine an element and use the result to find another element.

For instance, if we find one side and use the result to find another side, any error which is in the first result will appear in the next result. Choose a function (sine or tangent) that will bring in the unknown element together with other parts which

are given. When possible, get the unknown in the numerator and thus avoid division.

**650. Obtuse Angles.**—If we find in solving a triangle that the cosine is negative, then the angle is obtuse.

If  $\cos A = -.7660$ , then  $A$  is obtuse and its supplement  $A'$  has its cosine equal to  $+.7660$ .

From the table,  $A' = 40^\circ$ .

$$A = 180^\circ - 40^\circ = 140^\circ.$$

## CHAPTER XXVI

### POLAR COORDINATES

**651. Polar Coordinates.**—Another method of locating a point in a plane, besides the rectangular coordinates  $x$  and  $y$ , is by means of the vectorial angle  $\theta$  and the distance  $OP$ , measured along the generating line of the angle  $\theta$ .  $OP$  is called the radius vector and is usually denoted by  $\rho$ .

The radius vector  $\rho$  and the vectorial angle  $\theta$  are together called the polar coordinates of the point  $P$  and are indicated as  $(\rho, \theta)$  with the radius vector written first (see Art. 704).

If the vectorial angle is generated by a counterclockwise rotation,  $\theta$  is positive, and if it is generated by a clockwise rotation,  $\theta$  is negative.

The radius vector is measured from the pole  $O$  outwardly along the terminal line of the vectorial angle if positive, and along the terminal line of the angle produced beyond the pole if  $\rho$  is negative.

Thus, point  $P'$  is located by rotating the terminal line through the angle  $\theta$  and then measuring backward, on  $OP$  prolonged, a distance  $\rho$ . The coordinates of  $P'$  are then  $(-\rho, \theta)$ ;  $P'$  also has the coordinates  $(\rho, \theta_2)$  as noted in the figure in which  $\theta_2 = \theta + 180^\circ$ .

Polar coordinate paper, with angles and radians marked, can be purchased at technical supply stores and is very convenient in case the variable or argument is an angle measured in degrees or radians.

**652. Polar Graph of  $\rho = a \cos \theta$  [311].**—If the fixed length  $a$  be projected upon the generating line of the angle  $\theta$ , the length of the projection is  $\rho$ . The locus of the point  $P$ , as the angle  $\theta$  varies, is a circle, since a series of right triangles is formed, and according to geometry, the locus of  $P$  is at the vertex of a right

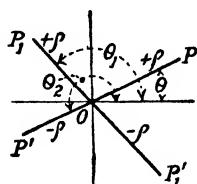

FIG. 309.

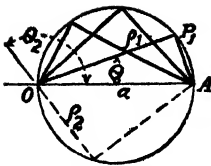

FIG. 310.

triangle whose hypotenuse is  $a$ . Therefore,  $P$  is on the semicircle  $AP_1O$ .

In like manner for  $\theta_2$ , the angle being in the second quadrant and the cosine negative, the length  $\rho_2$  is measured on the generating line prolonged through the pole as shown. The angle at  $P_2$  is also a right angle, and the semi-

circle  $OP_2A$  is described as  $\theta$  varies through the second quadrant.

As the angle  $\theta$  rotates through a complete revolution ( $360^\circ$  or  $2\pi$ ), the circle  $AP_1OP_2$  is traced twice.

The polar coordinates have an added advantage over the rectangular coordinates because  $OP$  possesses direction as well as length. Such a line is called a *vector*.

**653. Polar Graph of  $\rho = a \sin \theta$  [312].**—Since  $\rho = a \sin \theta$ , the radius vector must equal the side lying opposite the angle  $\theta$  in a right triangle of hypotenuse  $a$ . Therefore, the line  $OB$  perpendicular to  $OA$  is used instead of  $OA$ , as in the cosine graph.

The projection of  $a$  on the generating line of the angle  $\theta$  forms right triangles as was shown in the graph of  $\rho = a \cos \theta$  in the previous article.

The rotation of  $\theta_2$  in the second quadrant with  $P_2$ , the vertex of the right triangles, describes the semicircle  $BP_2O$ .

In the third and fourth quadrants, the sine is negative so that  $\rho$  must be laid off on the generating line prolonged.

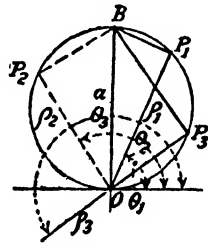

FIG. 311.

**654. Rotation of Polar Graphs.**—Since it is convenient to have on hand polar graphs of sines and cosines, it is also convenient to know what transformation is necessary in order to change a graph from  $\rho = \cos \theta$  to  $\rho = \cos (\theta \pm 15^\circ)$ .

For example, draw the circle that is the graph of  $\rho = \cos \theta$  and then rotate the axis through the second angle in the direction indicated by the sign.

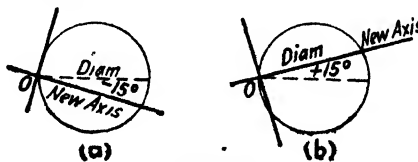

FIG. 312.

If, however, the graph is shifted rather than the axis, the direction of the rotation would be the reverse from that indicated by the sign.

So far, throughout this work, we have endeavored to avoid confusion by translating the origins and axes by moving in the direction indicated by the sign of the constant and always beginning with the simple graph which can be kept on hand.

### 655. Relation between Polar and Rectangular Coordinates.

From Fig. 313, the polar coordinates of  $P$  are  $(\rho, \theta)$ , and the rectangular coordinates are  $(x, y)$ .

Then

$$[313] \quad x = \rho \cos \theta \text{ and}$$

$$[314] \quad y = \rho \sin \theta$$

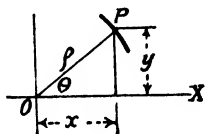

FIG. 313.

From this relation, any equation in rectangular coordinates can be transformed into an equation in polar coordinates which represents the same locus.

Thus the straight line,

$$x = 5,$$

becomes  $\rho \cos \theta = 5$ , and

$$2x + y = 4$$

becomes  $2\rho \cos \theta + \rho \sin \theta = 4$ .

The circle,  $x^2 + y^2 = a^2$ , when transformed, becomes

$$\rho^2 \cos^2 \theta + \rho^2 \sin^2 \theta = a^2, \text{ or}$$

$$\rho^2 (\cos^2 \theta + \sin^2 \theta) = a^2.$$

$$\rho^2 = a^2.$$

$$\rho = a.$$

The equations of transformation from *polar* equations to *rectangular* equations are

$$[315] \quad \theta = \tan^{-1} \frac{y}{x} \text{ and}$$

$$[316] \quad \rho = \sqrt{x^2 + y^2}.$$

From  $\theta = \tan^{-1} \frac{y}{x}$  we get the following equations which are found to be useful at times:

$$\theta = \cos^{-1} \frac{x}{\sqrt{x^2 + y^2}}, \quad \theta = \sin^{-1} \frac{y}{\sqrt{x^2 + y^2}}, \quad \tan \theta = \frac{y}{x},$$

$$\sin \theta = \frac{y}{\sqrt{x^2 + y^2}}, \text{ and } \cos \theta = \frac{x}{\sqrt{x^2 + y^2}}.$$

656. The Graph of  $\rho = a \cos \theta + b \sin \theta$  [317].—Assume a rectangle whose sides are  $a$  and  $b$  as shown (Fig. 314).

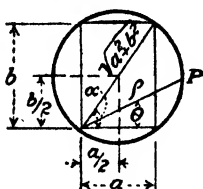

FIG. 314.

Draw a circumscribed circle about the rectangle.

The diagonal of the rectangle, as well as the diameter of the circle, will be

$$\sqrt{a^2 + b^2},$$

and the radius will be

$$\frac{1}{2}\sqrt{a^2 + b^2}.$$

The equation of this circle in rectangular coordinates, with the lower left-hand corner of the rectangle as origin  $O$  is

$$\left(x - \frac{a}{2}\right)^2 + \left(y - \frac{b}{2}\right)^2 = \left(\frac{1}{2}\sqrt{a^2 + b^2}\right)^2.$$

This is the equation of the circle,  $x^2 + y^2 = r^2$ , with the origin translated to  $\left(-\frac{a}{2}, -\frac{b}{2}\right)$ .

Expanding the above equation,

$$x^2 - ax + \frac{a^2}{4} + y^2 - by + \frac{b^2}{4} = \frac{a^2}{4} + \frac{b^2}{4}.$$

Canceling and collecting,

$$x^2 + y^2 = ax + by.$$

Now transform this into polar coordinates, remembering that

$$x^2 + y^2 = \rho^2, \quad x = \rho \cos \theta, \quad y = \rho \sin \theta.$$

Then

$$\rho^2 = a\rho \cos \theta + b\rho \sin \theta.$$

Dividing through by  $\rho$ ,

$$\rho = a \cos \theta + b \sin \theta,$$

or

$$\rho = \sqrt{a^2 + b^2} \left( \frac{a}{\sqrt{a^2 + b^2}} \cos \theta + \frac{b}{\sqrt{a^2 + b^2}} \sin \theta \right).$$

Now let

$$\alpha = \cos^{-1} \frac{a}{\sqrt{a^2 + b^2}} = \sin^{-1} \frac{b}{\sqrt{a^2 + b^2}},$$

and we have

$$\rho = \sqrt{a^2 + b^2} (\cos \alpha \cos \theta + \sin \alpha \sin \theta) = \sqrt{a^2 + b^2} \cos (\theta - \alpha),$$

which is the circle,  $\rho = \sqrt{a^2 + b^2} \cos \theta$ , rotated through an angle  $\alpha$  according to Art. 654.

The graph, then, of  $\rho = a \cos \theta + b \sin \theta$  is a circle with radius equal to  $\frac{1}{2}\sqrt{a^2 + b^2}$  and circumscribed about a rectangle whose sides are  $a$  and  $b$ .

If  $\rho'$  = the radius vector of  $a \cos \theta$  and  $\rho''$  = the radius vector of  $b \sin \theta$ , then  $\rho = \rho' + \rho''$ .

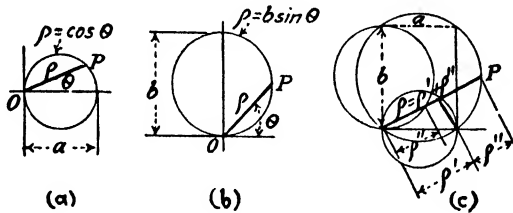

FIG. 315.

The graph shown in *c* above is made by combining the corresponding radius vectors in *a* and *b*. By means of a divider, two or more radius vectors may be added to determine the points of a graph.

**657. Time Element in Sine and Cosine Functions Using Polar Coordinates.**—The polar coordinates are very important in considering sine and cosine graphs as discussed in Art. 614 *et seq.*, especially in rotary motion. The discussion will be confined to the sine graph.

Consider the angle  $\omega$  in radians as the unit angle which the generating line (which may be a crank or a motor armature, as examples) generates in 1 second with uniform motion.

After  $t$  seconds, the generating line has moved through the angle  $\theta = \omega t$  radians.

Then  $\rho = a \sin \omega t$ .

**658.** If our angular velocity is .6981 radian per second, then

$$\rho = a \sin (.6981t).$$

The distance  $a$  would represent the length of the crank.

The period of the graph is the number of seconds required for each revolution.

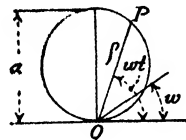

FIG. 316.

In Fig. 317 is shown the graph of a rotary motion having a period of 10 seconds; that is, 1 revolution requires 10 seconds.

It will be necessary for cases of very rapid rotation to construct the graph to divisions of time which are comparatively small, as tenths, or even hundredths, of a second. See in this connection Art. 614 where rectangular coordinates are used.

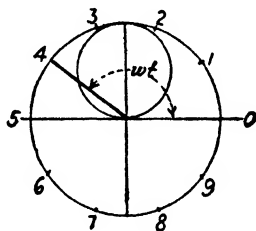

FIG. 317.

In case the angular measurement does not start from the horizontal position of the generating line but from a position below the horizontal, then

$$\rho = a \sin (\omega t - c).$$

Our graph would, then, take the form shown in Fig. 318.

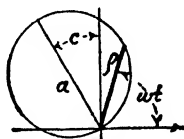

FIG. 318.

It must be borne in mind that the polar coordinates are not  $(\rho, t)$  but  $(\rho, \theta)$  where  $\theta = \omega t$ . Thus,  $\rho = a \sin (.6981t)$  is not a polar equation at all, but

$$\begin{aligned} \rho &= a \sin (.6981t) \text{ and} \\ \theta &= .6981t \end{aligned}$$

are a pair of parametric polar equations. It is possible to plot  $\rho = \sin \omega t$ , using  $t$  as the  $\theta$  coordinate, just as we use time as the  $x$  coordinate in rectangular coordinates, but this would give a very complicated curve, not a circle.

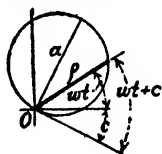
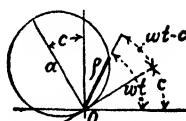
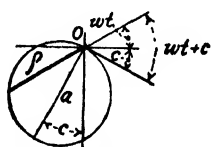
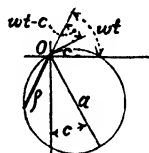
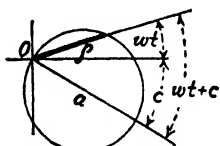
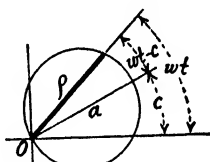
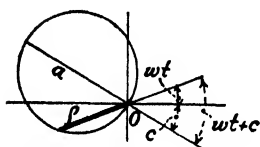
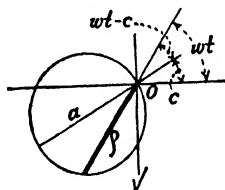

## 659. Polar Graphs of Sine and Cosine Functions.

FIG. 319.— $\rho = a \sin (\omega t + c)$ .FIG. 320.— $\rho = a \sin (\omega t - c)$ .FIG. 321.— $\rho = -a \sin (\omega t + c)$ .FIG. 322.— $\rho = -a \sin (\omega t - c)$ .FIG. 323.— $\rho = a \cos (\omega t + c)$ .FIG. 324.— $\rho = a \cos (\omega t - c)$ .FIG. 325.— $\rho = -a \cos (\omega t + c)$ .FIG. 326.— $\rho = -a \cos (\omega t - c)$ .

## CHAPTER XXVII

### VECTORS AND IMAGINARY AND COMPLEX NUMBERS

#### VECTORS

**660.** Vectors are directed line segments, and their use as a means of representing quantities which have a direction as well as a magnitude is a convenience. In addition, they afford the most convenient and simplest means of graphically representing complex numbers.

A quantity represented by a vector must possess direction as well as magnitude, and the direction and the magnitude are represented by the direction and length of the vector.

A force of a given magnitude acting in a certain direction, a velocity (magnitude and direction of speed), and many other quantities can be represented by directed line segments.

Two vectors are equal if they have the same magnitude and direction; hence, from any point in a plane as the initial point, a vector can be drawn equal to another coplanar vector.

**661. Addition of Vectors.**—If we have given two vectors,  $AB$  and  $BC$  (Fig. 327a), we may consider the first to represent a motion from  $A$  to  $B$  and the second a motion from  $B$  to  $C$ . The sum of the vectors, then, represents by definition the sum of the movements from  $A$  to  $B$  and from  $B$  to  $C$  which is the movement from  $A$  to  $C$ .

The sum of the vectors  $AB$  and  $BC$  is the *vector sum*  $AC$ , or  $AB + BC = AC$ .

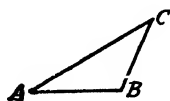

FIG. 327a.



FIG. 327b.

The sum of two vectors is the vector joining the initial point of the first to the terminal point of the second, providing that the initial point of the second vector is the terminal point of the first vector.

If two vectors start from the same origin, we can represent their sum by the diagonal of the parallelogram of which the vectors are adjacent sides (see Fig. 327b).

The projection of a vector on the coordinate axes gives the *components* of the vector, the projection on the horizontal axis being the horizontal component and the projection on the vertical axis being the vertical component, as is shown in Fig. 328, where the horizontal component of the vector  $AB$  is  $M_1M_2$  and the vertical component is  $N_1N_2$ . Also,

$$\text{Vector } AB = \text{Vector } M_1M_2 + \text{Vector } N_1N_2.$$

If all the vectors are parallel, the resultant vector is equal to the algebraic sum of the vectors in magnitude, and its direction is the same as that of all the vectors.

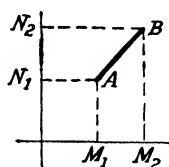

FIG. 328.

Vectors which are not parallel, as  $OA$  and  $AB$  in Fig. 329, are added by making the initial point of one coincide with the terminal point of the other. It is immaterial as to which vector is taken first. The vector which connects the initial point of the first with the terminal point of the second is a vector which represents the sum of the two vectors.

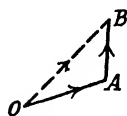

FIG. 329.

The first vector takes us from  $O$  to  $A$  and the second from  $A$  to  $B$ , which is equivalent to passing from  $O$  to  $B$  represented by the one vector  $OB$ .

EXAMPLE.—Consider a boat crossing a river in which the water is flowing at the rate of 3 miles per hour. The boat can cross at the rate of 4 miles per hour in still water.

Let  $AB$  = direction and speed of boat.

$BC$  = direction and speed of stream.

Fifteen minutes after starting, the boat would be at  $D$  in still water, but since in this length of time the current has carried the boat downstream a distance  $DE$ , the position of the boat at the end of this time is represented by the point  $E$ .  $DE = \frac{1}{4}$  mile.

Thirty minutes after starting, the boat would have traveled 2 miles in still water, but since the current has carried it  $1\frac{1}{2}$  miles downstream in this length of time, the point  $G$  represents its position.

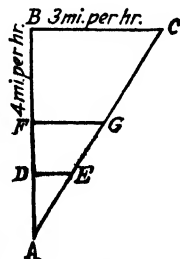

FIG. 330.

By following the path of the boat for the entire distance, we see that it lies in the direction  $AC$ . Since the vectors are velocity vectors, the

vector  $AC$  gives the magnitude and direction of the velocity of the boat with respect to an observer on the bank. Solving analytically,

$$AC = \sqrt{4^2 + 3^2} = \sqrt{25} = 5 \text{ miles per hour.}^2$$

**EXAMPLE.**—A cyclist travels due north at the rate of 15 miles per hour and the wind blows from the northwest at the rate of 10 miles per hour. What is the apparent velocity of the wind to the cyclist?



FIG. 331.

While traveling at the rate of 15 miles per hour with no wind blowing, his motion gives the effect of a 15-mile wind blowing from the north. Adding this to the 10-mile per hour wind from the northwest as shown gives a resultant vector which represents a wind velocity of 23.2 miles per hour.

**EXAMPLE.**—If the crank pin on a steam engine travels 10 feet per second, what velocity has the cross-head when the crank is at an angle of  $45^\circ$  with the horizontal? Length of the crank = 12 inches. Length of the connecting rod = 48 inches.

Draw a diagram of the crank as shown in Fig. 332 and draw a tangent  $BC$  to the circle at  $B$ , 10 units long. Draw  $BE$  normal to  $AB$ . This represents a velocity of the point  $B$  as it rotates about  $A$  and does not affect the velocity of the cross-head. Draw  $CD$  parallel to  $BE$  and  $BD$  horizontal, intersecting at  $D$ .  $BD$  represents the velocity of the cross-head.

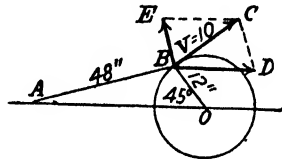

FIG. 332.

**EXAMPLE.**—Consider a rolling wheel of radius  $r$ , angular velocity  $\omega$ , and velocity of the center  $v_1$ .

The velocity of any point on the rim with respect to the center is  $r\omega = v_1$ . The absolute velocity of any point is the vector sum of its velocity with respect to the center and the absolute velocity of the center, as shown at  $B$ .

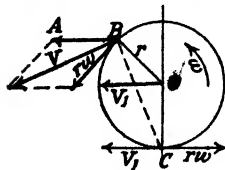

FIG. 333.

To find the velocity of  $B$  when located as shown, draw  $BA = v_1$  in the direction of  $v_1$ , *i.e.*, horizontally. Draw  $r\omega$  as shown, tangent to the circle at  $B$ . Complete the triangle which gives  $V$  as the velocity of  $B$  at that instant.

It will also be seen that  $V$  is perpendicular to  $BC$ , since points  $B$  and  $C$  are both on the wheel which is a rigid body. The point  $C$  has zero velocity.

### IMAGINARY AND COMPLEX NUMBERS

**662.** If an equation such as  $x^2 + 1 = 0$  is to have a solution at all, there must be some number whose square is  $-1$ . Call

this number  $i$  and we have  $i^2 = -1$  by definition. Assume that this number  $i$  can be combined with real numbers by the operations of addition, subtraction, multiplication, and division, obeying the ordinary algebraic laws for these operations.

**663. Graphs of Imaginary Units.**—If we graphically represent  $a$  on  $OA$  (Fig. 334), we start at the point  $O$  and measure to the right, or in the positive direction, a distance equal to  $a$  units.

If we multiply  $a$  by  $-1$ , we represent the result  $-a$  by measuring to the left, or in the negative direction, a distance equal to  $a$  units.

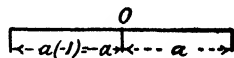

FIG. 334.

Multiplying a real number by  $-1$  is equivalent, geometrically, to rotating the line segment, which represents the number, about  $O$  through the two right angles so that the point which represents  $-a$  lies at the same distance from  $O$  as the point which represents  $a$  but in a direction opposite with relation to  $O$ .

Now  $i$  is such a number that  $i^2 = -1$ . Therefore, what we really have done is to multiply  $a$  by  $i^2$  or  $i \times i$ . If we now multiply  $a$  by  $i$ , which we may consider to be an operation which when performed twice is equivalent to a rotation about  $O$  through two right angles, this multiplication of  $a$  by  $i$  is equivalent, geometrically, to a rotation through one right angle.

The number  $ai$  will then be represented by a segment  $OB$  equal in length to  $OA$ , whose direction makes an angle of  $90^\circ$  with  $OA$  (Fig. 335).

In the same manner, if we multiply the real number  $a$  by  $i \times i \times i$ , the rotation is through three right angles, i.e.,  $i \times i \times i = i^3 = -i$ .

Multiplying by  $i \times i \times i \times i = i^4 = i^2 \times i^2 = 1$  is interpreted as a rotation through four right angles, or back to the starting point.

From the above, we also see that all even powers of  $i$  are either  $+1$  or  $-1$ , and all odd powers are either  $i$  or  $-i$ .

Since  $-i$  means  $-1 \cdot i$ ,  $(-i)^2 = (-1)^2 \cdot i^2 = 1 \cdot (-1)$ . Hence, we find a second number  $-i$  whose square is  $-1$ . If we designate that  $\sqrt{-1}$  is to mean the particular square root of

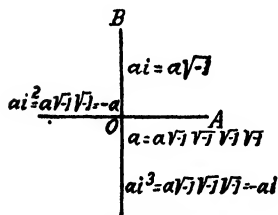

FIG. 335.

$-1$  which we call  $i$ , then  $-\sqrt{-1}$ , or  $-i$ , is the other square root of  $-1$ .

Now  $i$  is called the *imaginary unit* and  $ai$  an *imaginary number*, where  $a$  is any real number different from zero. The expression  $a + bi$  is called a *complex number*,  $a$  and  $b$  being any real numbers.

#### 664. Addition and Subtraction of Imaginary Numbers.

From the previous article,

$$0i = 0.$$

$$1i = i.$$

$$i + i = 2i.$$

$$i + i + i + i + \dots + i \text{ to } n \text{ terms} = ni, \quad (1)$$

$$\text{or } a\sqrt{-1} = ai.$$

$$\pm\sqrt{-a^2} = \pm\sqrt{a^2 \times (-1)} = \pm\sqrt{a^2} \cdot \sqrt{-1} = \pm a\sqrt{-1} = \pm ai. \quad (2)$$

$$ai + bi = (a + b)i. \quad (3)$$

**665. Multiplication and Division of Imaginaries.**—Formula (1) of the previous article [664] defines the multiplication of imaginaries by real numbers.

$$\sqrt{-1} \times \sqrt{-1} = i \cdot i = i^2 = -1.$$

Then

$$\sqrt{-a} \times \sqrt{-b} = \sqrt{a} \cdot \sqrt{b} \cdot i \cdot i = \sqrt{ab} \cdot (-1) = -\sqrt{ab}.$$

**RULE.**—The product of two imaginaries with like signs before the radicals is a negative real number. The product of two imaginaries with unlike signs is a positive real number.

In operating with imaginaries, a number in the form  $\sqrt{-a}$  should always be written in the form  $\sqrt{a} \cdot i$ , for obvious reasons. Thus in the division of imaginaries,

$$\frac{\sqrt{-a}}{\sqrt{-b}} = \frac{\sqrt{a} \cdot i}{\sqrt{b} \cdot i} = \sqrt{\frac{a}{b}}.$$

**666. Meaning of Complex Numbers.**—Any real number, or any expression containing only real numbers, may be considered as locating a point on a line.

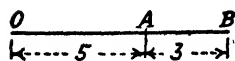

FIG. 336.

Consider the expression  $5 + 3$ , and let  $O$  be the point represented by zero on the line  $OB$ .  $OA$  con-

tains 5 units,  $AB$  contains 3 units, and  $OA + AB = OB = 5 + 3$ ; that is,  $OB$  is the graphical representation of  $5 + 3$ .

In an analogous manner, an expression as  $a + bi$ , which is called a *complex* number, may be taken as the representation of a point in a plane.

The real portion of the complex number is measured along the horizontal axis, and the imaginary portion is laid off along the vertical axis. The axes are called, respectively, the *axis of reals* and the *axis of imaginaries*. Thus, the point  $P$  which represents the complex number  $a + bi$  is the point whose abscissa is  $a$  and whose ordinate is  $b$ .

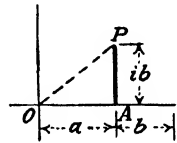

FIG. 337.

The distance  $OP$  is called the *modulus* of the number  $a + bi$  and is readily seen to be equal to  $\sqrt{a^2 + b^2}$ .

667. Complex numbers are quite common, often occurring as roots of equations of higher degree than the first, and their introduction makes possible the solution of equations not possible without them.

Assume a quadratic equation, as

$$x^2 - 8x + 18 = 0$$

whose roots are

$$x = 4 + 1.41\sqrt{-1} \text{ and}$$

$$x = 4 - 1.41\sqrt{-1}.$$

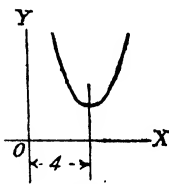

FIG. 338.

Constructing the graph, it is evident that the graph does not intersect the  $X$ -axis, and the equation has no real roots.

In the solution of quadratic equations with negative discriminants, resolve them into expressions which consist of a real number associated with an imaginary number by plus or minus signs.

668. **Vector Representation.**—If we represent  $a$  by a horizontal line segment, measured to the right if  $a$  is positive and to the left if  $a$  is negative, and the imaginary number  $ai$  as a vertical segment, measured upward if  $a$  is positive and downward if  $a$  is negative, this then suggests the possibility of representing complex numbers by segments having other directions in the plane.

**669. The Complex Number,  $x + yi$ .**—If  $x$  be a real number and  $yi$  an imaginary number, then the vector  $OP$  will be the sum of the two components or  $OP = x + yi$ .

*Conversely*, every number of the form  $x + yi$  represents a definite vector in the plane.

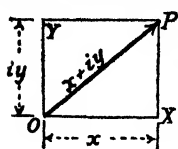

FIG. 339.

If its initial point is at the origin, its terminal point is at the point  $(x, y)$ .

If we consider the vector as starting at  $O$ , the point  $(x, y)$  determines the vector. We can, therefore, represent a point in a plane by a complex number, *viz.*, the number  $x + yi$  will represent the point whose rectangular coordinates are  $(x, y)$ .

This representation of  $x + iy$  is the same as the representation already described in Art. 666.

**EXAMPLE OF ADDITION.**—Represent by vectors the complex numbers  $2 + 2i$  and  $1 + 6i$  and find their sum.

Vector  $OA$  represents the complex number  $2 + 2i$ .

Vector  $OB$  represents the complex number  $1 + 6i$ .

The sum of the two vectors is the vector  $OC$ .

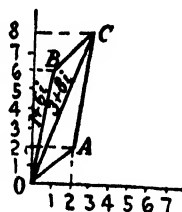

FIG. 340.

**EXAMPLE OF SUBTRACTION.**—Find the vector that represents  $(1 + i) - (2 - 3i)$ .

Since the subtrahend plus the remainder equals the

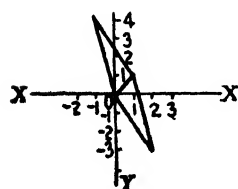

FIG. 341.

minuend, we can apply the above principle of addition by making the vector  $2 - 3i$  and the vector sought, the adjacent sides of the parallelogram, and the vector  $1 + i$  the diagonal.

Since we represent a complex number by the terminus of a vector, two complex numbers are, therefore, equal only if they represent the same point, that is, if they have their real and imaginary parts respectively equal. The two abscissae must be equal and the two ordinates must be equal. Also, if  $x + yi = 0$ , then  $x = 0$  and  $yi = 0$ .

**670. Conjugate Complex Numbers.**—Two complex numbers are said to be conjugate if they differ only in the sign of the term containing  $i$ .

Conjugate imaginaries have a real sum and a real product,

$$(x + iy) + (x - iy) = x + iy + x - iy = x + x + iy - iy = 2x.$$

$$(x + iy)(x - iy) = x^2 - y^2i^2 = x^2 + y^2.$$



The product of two conjugate complex numbers is always positive and the sum of two squares. The sum, product, or quotient of two complex numbers is always a complex number of the typical form  $a + bi$ .

EXAMPLE.

$$(x + yi) + (u + vi) = x + u + (y + v)i.$$

Also,

$$(x + yi)(u + vi) = (xu - yv) + (xv + yu)i.$$

**671.** If a complex number is equal to zero, the real part and the imaginary part are separately equal to zero.

If two complex numbers are equal, then the real parts and the imaginary parts are, respectively, equal.

EXAMPLE.

If  $x + yi = u + vi$ ,  
then  $x = u$  and  $iy = iv$ .

Complex numbers obey the laws of algebra through the fundamental operations.

**672. Multiplication of Complex Numbers.**—The multiplication is performed in accord with the algebraic laws as in the case of real numbers,

$$(x_1 + iy_1)(x_2 + iy_2) = x_1x_2 + iy_1x_2 + iy_2x_1 + i^2y_1y_2 = (x_1x_2 - y_1y_2) + (x_1y_2 + x_2y_1)i.$$

**673. Division of Complex Numbers.**

$\frac{x_1 + iy_1}{x_2 + iy_2}$  can be simplified by multiplying both the numerator and the denominator by  $x_2 - iy_2$ , the conjugate of the denominator. This makes the denominator a real number.

$$\frac{x_1 + iy_1}{x_2 + iy_2} = \frac{x_1x_2 + iy_1x_2 - ix_1y_2 - i^2y_1y_2}{(x_2)^2 + (y_2)^2} = \frac{x_1x_2 + y_1y_2}{(x_2)^2 + (y_2)^2} - i \frac{x_1y_2 - x_2y_1}{(x_2)^2 + (y_2)^2}$$

**674. Polar Form of Complex Numbers.**—The point  $P(x, y)$  in rectangular coordinates represents the complex number  $x + yi$  to the origin  $O$ .

If we let  $(\rho, \theta)$  be the polar coordinates of  $P$  ( $\rho \geq 0$ ), with  $O$  the origin and  $OX$  axis as the initial line, then

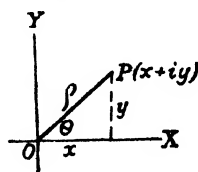

FIG. 342.

$$x = \rho \cos \theta \text{ and} \\ y = \rho \sin \theta,$$

or

$$[318] \quad x + yi = \rho(\cos \theta + i \sin \theta),$$

where  $\rho \geq 0$ .

The right-hand member of the equation is called the polar form. The angle  $\theta$  is known as the argument or amplitude, and  $\rho$  is called the modulus or absolute value of the complex number.

EXAMPLE.—Find the argument, the absolute value, and the polar form of the complex number  $2 + i2\sqrt{3}$ .

Comparing  $2 + i2\sqrt{3}$  to the general complex form  $x + iy$ ,  $x = 2$  and  $y = 2\sqrt{3}$ .

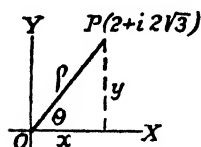

FIG. 343.

Since

$$\rho = \sqrt{x^2 + y^2} = \sqrt{4 + 12} = 4, \quad [316]$$

the absolute value  $\rho$  is 4.

Moreover,

$$\tan \theta = \frac{y}{x} = \frac{2\sqrt{3}}{2} = \sqrt{3}. \quad [315]$$

$\therefore$  the argument  $\theta$  equals  $60^\circ$ .

The polar form is  $4(\cos 60^\circ + i \sin 60^\circ)$ .

**675.** The polar form,  $\rho(\cos \theta + i \sin \theta)$ , is the expression of the complex number  $x + iy$  in terms of its modulus and amplitude.

The operator  $(\cos \theta + i \sin \theta)$  which depends on  $\theta$  alone turns the unit lying along  $OX$  through an angle  $\theta$  and may, therefore, be looked upon as a *versor* of rotative power  $\theta$ . This versor is often abbreviated to *cis*  $\theta$ .

The operator  $\rho$  is a *tensor*, which stretches the turned unit in the ratio of  $1 : \rho$ .

The result of the application of these two operators to the unit vector is to locate the point  $P$  at a distance of  $\rho$  units from the origin in a direction making an angle  $\theta$  with  $OX$ .

It will be seen that the operator  $(\cos \theta + i \sin \theta)$  is simply a more general operator than  $i$  but of the same kind. The operator  $i$  turns a unit through a right angle and the operator  $(\cos \theta + i \sin \theta)$  turns a unit through an angle  $\theta$ .

If  $\theta$  be put equal to  $90^\circ$ ,  $(\cos \theta + i \sin \theta)$  reduces to  $i$ .

Since  $3 - 4i = 5(\frac{3}{5} - \frac{4}{5}i)$ , the point represented by  $3 - 4i$  may be located by turning the unit vector through an angle

$\theta = \sin^{-1}(-\frac{4}{5}) = \cos^{-1}(\frac{3}{5})$  and stretching the result in the ratio of 1:5.

**676. Multiplication of Complex Numbers in the Polar Form.**—  
If two complex numbers are written in the polar form,

$$\begin{aligned}x_1 + iy_1 &= \rho_1(\cos \theta_1 + i \sin \theta_1) \text{ and} \\x_2 + iy_2 &= \rho_2(\cos \theta_2 + i \sin \theta_2).\end{aligned}$$

If we multiply the right members of the equations together, we have

$$\begin{aligned}\rho_1\rho_2[\cos \theta_1 \cos \theta_2 + i(\sin \theta_1 \cos \theta_2 + \cos \theta_1 \sin \theta_2) - \sin \theta_1 \sin \theta_2] \\= \rho_1\rho_2[\cos (\theta_1 + \theta_2) + i \sin (\theta_1 + \theta_2)].\end{aligned}$$

See [306] to [308] for reduction.

Therefore, the absolute value of the product of two complex numbers is equal to the product of their absolute values, and the angle of the product is equal to the sum of their angles.

EXAMPLE.—Find the product of  $(1 + i)(3 + i\sqrt{3})$ .

Reducing to polar form as in Art. 674,

$$\sqrt{2}(\cos 45^\circ + i \sin 45^\circ) \text{ and}$$

$$2\sqrt{3}(\cos 30^\circ + i \sin 30^\circ) \text{ are the two equations.}$$

Therefore,

$$\theta_1 = 45^\circ, \theta_2 = 30^\circ.$$

$$\rho_1 = \sqrt{2}, \rho_2 = 2\sqrt{3}.$$

$$\theta_1 + \theta_2 = 75^\circ.$$

$$\rho_1\rho_2 = 2\sqrt{6}.$$

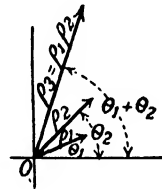

FIG. 344.

Therefore, the product is  $2\sqrt{6}(\cos 75^\circ + i \sin 75^\circ)$  by polar coordinates.

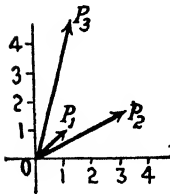

FIG. 345.

The multiplication is shown graphically in

Fig. 345, by rectangular coordinates, where  $P_1$  represents  $1 + i$ .

$P_2$  represents  $3 + i\sqrt{3}$ .

$$\begin{aligned}P_3 \text{ represents } (1 + i)(3 + i\sqrt{3}) &= \\(3 - \sqrt{3}) + i(3 + \sqrt{3}) &= \\(3 - 1.73) + i(3 + 1.73) &= \\1.27 + 4.73i.\end{aligned}$$

$x + yi = 1.27 + 4.73i$  by rectangular coordinates, and

$\rho(\cos \theta + i \sin \theta) = 2\sqrt{6}(\cos 75^\circ + i \sin 75^\circ)$   
 $= 4.898 \times .2588 + i 4.898 \times .9659 = 1.27 + 4.73i$  by polar coordinates. From [318]  $x + yi = \rho(\cos \theta + i \sin \theta)$ . A comparison shows that the two methods check.

**677. Division of Complex Numbers in the Polar Form.**—If we write the two complex numbers in the polar form, we have

$$\begin{aligned} & \frac{\rho_1 (\cos \theta_1 + i \sin \theta_1)}{\rho_2 (\cos \theta_2 + i \sin \theta_2)} = \\ & \frac{\rho_1 (\cos \theta_1 + i \sin \theta_1)(\cos \theta_2 - i \sin \theta_2)}{\rho_2 (\cos \theta_2 + i \sin \theta_2)(\cos \theta_2 - i \sin \theta_2)} = \\ & \frac{\rho_1 [\cos (\theta_1 - \theta_2) + i \sin (\theta_1 - \theta_2)]}{\rho_2 (\cos^2 \theta_2 + \sin^2 \theta_2)} = \\ & \frac{\rho_1}{\rho_2} [\cos (\theta_1 - \theta_2) + i \sin (\theta_1 - \theta_2)]. \end{aligned}$$

Therefore, the absolute value of the quotient of two complex numbers is the quotient of their absolute values, and the angle of the quotient is the difference of their angles.

**EXAMPLE.**—Find, analytically and graphically, the quotient,

$$\begin{aligned} & \frac{3 + i\sqrt{3}}{1 + i} = \frac{3 + i\sqrt{3}}{1 + i} \cdot \frac{1 - i}{1 - i} = \\ & \frac{(3 + \sqrt{3}) - i(3 - \sqrt{3})}{2} = \\ & \frac{3 + \sqrt{3}}{2} - \frac{3 - \sqrt{3}}{2}i = \\ & \frac{3 + 1.732}{2} - \frac{3 - 1.732}{2}i = 2.366 - .634i. \end{aligned}$$

Using polar equations

$$\begin{aligned} \rho_1 &= \sqrt{3^2 + (\sqrt{3})^2} = 2\sqrt{3}. \\ \rho_2 &= \sqrt{1^2 + 1^2} = \sqrt{2}. \\ \tan \theta_1 &= \frac{\sqrt{3}}{3} = \frac{1}{\sqrt{3}}. \quad \theta_1 = 30^\circ. \\ \tan \theta_2 &= \frac{1}{1} = 1. \quad \theta_2 = 45^\circ. \\ \frac{\rho_1}{\rho_2} &= \frac{2\sqrt{3}}{\sqrt{2}} = 2.45. \\ \theta_1 - \theta_2 &= 30^\circ - 45^\circ = -15^\circ. \\ \frac{3 + i\sqrt{3}}{1 + i} &= 2.45 [\cos (-15^\circ) + i \sin (-15^\circ)]. \\ &= 2.45 [\cos (-15^\circ) + i \sin (-15^\circ)] = \\ &= 2.45 \times .9659 - 2.45 \times .2588i = 2.366 - .634i, \end{aligned}$$

which checks with the above result.

The graphical solution is shown in Fig. 346, where

$$P_1 \text{ represents } 3 + i\sqrt{3}.$$

$$P_2 \text{ represents } 1 + i.$$

$$P_3 \text{ represents } \frac{3 + i\sqrt{3}}{1 + i}.$$

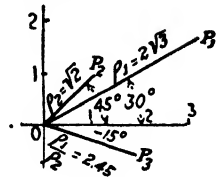

FIG. 346.

**678. De Moivre's theorem** states that

$$[319] (\cos \theta + i \sin \theta)^n = \cos n\theta + i \sin n\theta,$$

whether  $n$  is positive or negative, fractional or integral.

The theorem of Art. 676 also holds for the product of any number of complex numbers; that is,

1. The absolute value of the product of any number of complex numbers is equal to the product of their absolute values.

2. The angle of the product of any number of complex numbers is equal to the sum of their angles.

Then

$$[\rho (\cos \theta + i \sin \theta)]^n = \rho^n (\cos n\theta + i \sin n\theta).$$

If  $\rho = 1$ , this becomes

$$(\cos \theta + i \sin \theta)^n = \cos n\theta + i \sin n\theta,$$

which expresses De Moivre's theorem.

$$(\cos \theta + i \sin \theta)^{-1} = \cos (-\theta) + i \sin (-\theta).$$

$$(\cos \theta + i \sin \theta)^{-p} = \cos (-p\theta) + i \sin (-p\theta).$$

$$(\cos \theta + i \sin \theta)^{\frac{1}{q}} = \cos \left( \frac{\theta}{q} \right) + i \sin \left( \frac{\theta}{q} \right).$$

$$(\cos \theta + i \sin \theta)^{\frac{p}{q}} = \cos \left( \frac{p\theta}{q} \right) + i \sin \left( \frac{p\theta}{q} \right).$$

The general formulation of the problem of finding the  $n$ th roots of a number,  $z = \rho(\cos \theta + i \sin \theta)$ , is

$$[320] z = \rho [\cos (\theta + k \cdot 360^\circ) + i \sin (\theta + k \cdot 360^\circ)]$$

where  $k$  is an integer. Or

$$\frac{1}{z^n} = \rho^{\frac{1}{n}} \left[ \cos \left( \frac{\theta + k \cdot 360^\circ}{n} \right) + i \sin \left( \frac{\theta + k \cdot 360^\circ}{n} \right) \right].$$

The  $n$  values of  $k$ ,  $0, 1, 2, 3, 4, \dots, n - 1$ , give  $n$  values for  $z^n$ , and no more values are possible.

**EXAMPLE.**—Find the fifth roots of  $(2 + 2i)$ .

$$(2 + 2i) = 2\sqrt{2} (\cos [45^\circ + k \cdot 360^\circ] + i \sin [45^\circ + k \cdot 360^\circ]),$$

and

$$(2 + 2i)^{\frac{1}{5}} = (2\sqrt{2})^{\frac{1}{5}} [\cos (9^\circ + k \cdot 72^\circ) + i \sin (9^\circ + k \cdot 72^\circ)].$$

For values of  $k = 0, 1, 2, 3, 4$ , we get the five roots,

$$\begin{aligned} &(2\sqrt{2})^{\frac{1}{2}} (\cos 9^\circ + i \sin 9^\circ), \\ &(2\sqrt{2})^{\frac{1}{2}} (\cos 81^\circ + i \sin 81^\circ), \\ &(2\sqrt{2})^{\frac{1}{2}} (\cos 153^\circ + i \sin 153^\circ), \\ &(2\sqrt{2})^{\frac{1}{2}} (\cos 225^\circ + i \sin 225^\circ), \text{ and} \\ &(2\sqrt{2})^{\frac{1}{2}} (\cos 297^\circ + i \sin 297^\circ). \end{aligned}$$

All the above roots are different and may be evaluated by using a table of natural functions.

### 679. Application of De Moivre's Theorem to Trigonometry.

Case 1.—To express  $\cos n\theta$  and  $\sin n\theta$  in terms of  $\cos \theta$  and  $\sin \theta$ , where  $n$  is a positive integer.

From De Moivre's theorem,

$$\begin{aligned} \cos n\theta + i \sin n\theta &= (\cos \theta + i \sin \theta)^n = \\ \cos^n \theta + n \cdot i \cdot \cos^{n-1} \theta \cdot \sin \theta + \frac{n(n-1)}{2} i^2 \cdot \cos^{n-2} \theta \cdot \sin^2 \theta + \end{aligned}$$

Now equate the real and the imaginary parts of the equation, which gives the desired expression.

EXAMPLE.—Express  $\cos(6\theta)$  and  $\sin(6\theta)$  in terms of  $\cos \theta$  and  $\sin \theta$ .

$$\begin{aligned} \cos 6\theta + i \sin 6\theta &= (\cos \theta + i \sin \theta)^6 = \cos^6 \theta + \\ &6i \cos^5 \theta \cdot \sin \theta + (-15) \cos^4 \theta \cdot \sin^2 \theta + (-20)i \cos^3 \theta \cdot \sin^3 \theta \\ &+ 15 \cos^2 \theta \cdot \sin^4 \theta + 6i \cos \theta \cdot \sin^5 \theta - \sin^6 \theta. \end{aligned}$$

Equating the real parts,

$$\cos 6\theta = \cos^6 \theta - 15 \cos^4 \theta \cdot \sin^2 \theta + 15 \cos^2 \theta \cdot \sin^4 \theta - \sin^6 \theta.$$

Equating the imaginary parts after dividing by  $i$ ,

$$\sin 6\theta = 6 \cos^5 \theta \cdot \sin \theta - 20 \cos^3 \theta \cdot \sin^3 \theta + 6 \cos \theta \cdot \sin^5 \theta.$$

Case 2.—To express  $\cos^n \theta$  and  $\sin^n \theta$  in terms of sines and cosines of multiples of  $\theta$ , we place  $u = \cos \theta + i \sin \theta$ , and we have

$$u^k = \cos k\theta + i \sin k\theta \text{ and}$$

$$u^{-k} = \cos -k\theta + i \sin -k\theta = \cos k\theta - i \sin k\theta.$$

Adding and subtracting these equations,

$$u^k + u^{-k} = 2 \cos k\theta \text{ and}$$

$$u^k - u^{-k} = 2i \sin k\theta,$$

for any integral value of  $k$ .

If  $k = 1$ ,

$$2 \cos \theta = u + u^{-1}.$$

$$2i \sin \theta = u - u^{-1}.$$

$$\therefore 2^n \cos^n \theta = (u + u^{-1})^n = u^n + nu^{n-2} + \frac{n(n-1)}{2} u^{n-4} + \dots + nu^{-(n-2)} + u^{-n}.$$

The coefficients of the binomial expansion are equal in pairs and can, therefore, be grouped as follows:

$$2^n \cos^n \theta = (u^n + u^{-n}) + n(u^{n-2} + u^{-(n-2)}) + \dots$$

But the terms in parentheses are equal, respectively, to  $2 \cos n\theta, 2 \cos (n - 2)\theta, \dots$

EXAMPLE.—Express  $\cos^4 \theta$  in terms of cosines of multiples of  $\theta$ .

We set

$$\begin{aligned} 2^4 \cos^4 \theta &= (u + u^{-1})^4 = u^4 + 4u^2 + 6 + 4u^{-2} + u^{-4} \\ &= u^4 + u^{-4} + 4(u^2 + u^{-2}) + 6 \\ &= 2 \cos 4\theta + 4 \cdot 2 \cos 2\theta + 6. \end{aligned}$$

Dividing both sides by  $2^4$ ,

$$\cos^4 \theta = \frac{1}{8}(\cos 4\theta + 4 \cos 2\theta + 3).$$

EXAMPLE.—Express  $\sin^5 \theta$  in terms of sines of multiples of  $\theta$ .

We set

$$\begin{aligned} 2^5 i^5 \sin^5 \theta &= (u - u^{-1})^5, \text{ or} \\ 32i \sin^5 \theta &= u^5 - 5u^3 + 10u - 10u^{-1} + 5u^{-3} - u^{-5} = \\ &= (u^5 - u^{-5}) - 5(u^3 - u^{-3}) + 10(u - u^{-1}) = \\ &= 2i \sin 5\theta - 5 \cdot 2i \sin 3\theta + 10 \cdot 2i \sin \theta, \text{ whence} \\ \sin^5 \theta &= \frac{1}{16} (\sin 5\theta - 5 \sin 3\theta + 10 \sin \theta). \end{aligned}$$

### 680. Expansion of $\sin n\theta$ and $\cos n\theta$ by De Moivre's Theorem and the Binomial Theorem.

$$\begin{aligned} \cos n\theta + i \sin n\theta &= (\cos \theta + i \sin \theta)^n = \\ \cos^n \theta + ni \cos^{n-1} \theta \cdot \sin \theta - \frac{n(n-1)}{2} \cos^{n-2} \theta \cdot \sin^2 \theta + \\ &\quad - \frac{in(n-1)(n-2)}{3} \cos^{n-3} \theta \cdot \sin^3 \theta + \\ &\quad \frac{n(n-1)(n-2)(n-3)}{4} \cos^{n-4} \theta \cdot \sin^4 \theta + \\ &\quad \frac{in(n-1)(n-2)(n-3)(n-4)}{5} \cos^{n-5} \theta \cdot \sin^5 \theta + \dots \end{aligned}$$

Equating the real parts,

$$\begin{aligned} \cos n\theta &= \cos^n \theta - \frac{n(n-1)}{2} \cos^{n-2} \theta \cdot \sin^2 \theta + \\ &\quad \frac{n(n-1)(n-2)(n-3)}{4} \cos^{n-4} \theta \cdot \sin^4 \theta + \dots \end{aligned}$$

Let  $\alpha = n\theta$ . Then  $\theta = \frac{\alpha}{n}$  and  $n = \frac{\alpha}{\theta}$ , where  $\alpha$  is to remain constant while  $n$  and  $\theta$  vary.

Substituting these values,

$$\begin{aligned} \cos \alpha &= \cos^n \theta - \frac{\frac{\alpha}{\theta} \left( \frac{\alpha}{\theta} - 1 \right)}{|2|} \cos^{n-2} \theta \cdot \sin^2 \theta + \\ &\quad \frac{\frac{\alpha}{\theta} \left( \frac{\alpha}{\theta} - 1 \right) \left( \frac{\alpha}{\theta} - 2 \right) \left( \frac{\alpha}{\theta} - 3 \right)}{|4|} \cos^{n-4} \theta \cdot \sin^4 \theta + \dots \\ &= \cos^n \theta - \frac{\alpha(\alpha - \theta)}{2} \cos^{n-2} \theta \cdot \left( \frac{\sin \theta}{\theta} \right)^2 + \\ &\quad \frac{\alpha(\alpha - \theta)(\alpha - 2\theta)(\alpha - 3\theta)}{|4|} \cos^{n-4} \theta \cdot \left( \frac{\sin \theta}{\theta} \right)^4 + \dots \end{aligned}$$

Now as  $n$  becomes infinite,  $\frac{\alpha}{n}$  approaches zero,  $\cos \theta \rightarrow 1$ ,  $\frac{\sin \theta}{\theta} \rightarrow 1$ , and  $\alpha - \theta \rightarrow \alpha$ .

Therefore,

[321] 
$$\cos \alpha = 1 - \frac{\alpha^2}{|2|} + \frac{\alpha^4}{|4|} - \frac{\alpha^6}{|6|} + \dots$$

$\alpha$  is measured in radians.

Equating the coefficients of the imaginary parts,

$$\begin{aligned} \sin n\theta &= n \cdot \cos^{n-1} \theta \cdot \sin \theta - \frac{n(n-1)(n-2)}{|3|} \cos^{n-3} \theta \cdot \sin^3 \theta + \\ &\quad \frac{n(n-1)(n-2)(n-3)(n-4)}{|5|} \cos^{n-5} \theta \cdot \sin^5 \theta + \dots \end{aligned}$$

Making the substitutions for  $\theta$  and  $n$  as above,

$$\begin{aligned} \sin \alpha &= \alpha \cdot \cos^{n-1} \theta \cdot \left( \frac{\sin \theta}{\theta} \right) - \frac{\alpha(\alpha - \theta)(\alpha - 2\theta)}{|3|} \cos^{n-3} \theta \cdot \left( \frac{\sin \theta}{\theta} \right)^3 \\ &+ \frac{\alpha(\alpha - \theta)(\alpha - 2\theta)(\alpha - 3\theta)(\alpha - 4\theta)}{|5|} \cos^{n-5} \theta \cdot \left( \frac{\sin \theta}{\theta} \right)^5 + \dots \end{aligned}$$

Then, taking the limits as  $n$  becomes infinite,

[322] 
$$\sin \alpha = \alpha - \frac{\alpha^3}{|3|} + \frac{\alpha^5}{|5|} - \frac{\alpha^7}{|7|} + \dots$$

$\alpha$  is in radians as before.

The above series for sine and cosine are used in computing the tables of sines and cosines (see calculus section, Art. 980).

**681. Exponential Values of  $\sin \theta$ ,  $\cos \theta$ , and  $\tan \theta$ .**

From algebra (Art. 462),

$$e^x = 1 + x + \frac{x^2}{|2|} + \frac{x^3}{|3|} + \frac{x^4}{|4|} + \dots \tag{1}$$



If  $e^{i\theta}$  is substituted for  $x$ , where  $i = \sqrt{-1}$ , then

$$e^{i\theta} = 1 + i\theta + \frac{i^2\theta^2}{|2} + \frac{i^3\theta^3}{|3} + \frac{i^4\theta^4}{|4} + \dots$$

$$= \left(1 - \frac{\theta^2}{2} + \frac{\theta^4}{4} - \frac{\theta^6}{6} + \dots\right) + i\left(\theta - \frac{\theta^3}{3} + \frac{\theta^5}{5} - \frac{\theta^7}{7} + \dots\right)$$

But from the previous article, the expressions in the parentheses are, respectively, equal to  $\cos \theta$  and  $\sin \theta$ , or

$$e^{i\theta} = \cos \theta + i \sin \theta. \tag{2}$$

Substituting  $x = -i\theta$  above, then

$$e^{-i\theta} = \cos \theta - i \sin \theta. \tag{3}$$

Subtracting (3) from (2),

$$\sin \theta = \frac{e^{i\theta} - e^{-i\theta}}{2i}. \tag{4}$$

Adding (2) and (3),

$$\cos \theta = \frac{e^{i\theta} + e^{-i\theta}}{2}. \tag{5}$$

Dividing (4) by (5),

$$\tan \theta = \frac{e^{i\theta} - e^{-i\theta}}{i(e^{i\theta} + e^{-i\theta})}.$$

**682. Exponential Forms of Complex Numbers.**—From the previous article,

$$\cos \theta + i \sin \theta = e^{i\theta}.$$

Then

$$x + iy = \rho(\cos \theta + i \sin \theta) = \rho e^{i\theta},$$

$\theta$  expressed in radians.

Thus, if

$$x_1 + iy_1 = \rho_1(\cos \theta_1 + i \sin \theta_1) = \rho_1 e^{i\theta_1} \text{ and}$$

$$x_2 + iy_2 = \rho_2(\cos \theta_2 + i \sin \theta_2) = \rho_2 e^{i\theta_2},$$

then

$$(x_1 + iy_1)(x_2 + iy_2) = \rho_1 \rho_2 e^{i(\theta_1 + \theta_2)}.$$

## CHAPTER XXVIII

### HYPERBOLIC FUNCTIONS

**683. Hyperbolic Functions.**—Certain combinations of the sum and difference of two exponential functions as  $e^u + e^{-u}$  and  $e^u - e^{-u}$  occur so often in mathematical work that they have been given the special name of *hyperbolic functions*. They are defined as follows:

$\frac{e^u - e^{-u}}{2}$  is called the hyperbolic sine of  $u$  and designated by  $\sinh u$ , or

$$\sinh u = \frac{e^u - e^{-u}}{2}.$$

$\frac{e^u + e^{-u}}{2}$  is called the hyperbolic cosine of  $u$  and designated by  $\cosh u$ , or

$$\cosh u = \frac{e^u + e^{-u}}{2}.$$

Likewise,

$$\tanh u = \frac{\sinh u}{\cosh u} = \frac{e^u - e^{-u}}{e^u + e^{-u}}.$$

$$\coth u = \frac{1}{\tanh u} = \frac{e^u + e^{-u}}{e^u - e^{-u}}.$$

$$\operatorname{sech} u = \frac{1}{\cosh u} = \frac{2}{e^u + e^{-u}}.$$

$$\operatorname{cosech} u = \frac{1}{\sinh u} = \frac{2}{e^u - e^{-u}}.$$

**684.** The following formulae analogous to the circular functions can easily be obtained from the definitions above:

$$\cosh^2 u - \sinh^2 u = 1,$$

for

$$\left(\frac{e^u + e^{-u}}{2}\right)^2 - \left(\frac{e^u - e^{-u}}{2}\right)^2 = \frac{e^{2u} + 2 + e^{-2u}}{4} - \frac{e^{2u} - 2 + e^{-2u}}{4} = 1.$$

In a similar manner it can be proved that

$$\operatorname{sech}^2 u + \tanh^2 u = 1.$$

$$\operatorname{ctnh}^2 u - \operatorname{csch}^2 u = 1.$$

$$\begin{aligned} \sinh u &= \sqrt{\cosh^2 u - 1} = \frac{\tanh u}{\sqrt{1 - \tanh^2 u}} \\ &= \frac{1}{\sqrt{\operatorname{ctnh}^2 u - 1}} = \frac{1}{\operatorname{sech} u} = \frac{1}{\operatorname{csch} u}. \end{aligned}$$

$$\begin{aligned} \cosh u &= \sqrt{\sinh^2 u + 1} = \frac{1}{\sqrt{1 - \tanh^2 u}} \\ &= \frac{\operatorname{ctnh} u}{\sqrt{\operatorname{ctnh}^2 u - 1}} = \frac{1}{\operatorname{csch} u} = \frac{1}{\operatorname{sech} u}. \end{aligned}$$

$$\begin{aligned} \tanh u &= \frac{\sinh u}{\sqrt{\sinh^2 u + 1}} = \frac{\sqrt{\cosh^2 u - 1}}{\cosh u} \\ &= \sqrt{1 - \operatorname{sech}^2 u} = \frac{1}{\sqrt{\operatorname{csch}^2 u + 1}} = \frac{1}{\operatorname{ctnh} u}. \end{aligned}$$

$$\sinh(u \pm v) = \frac{e^{u \pm v} - e^{-(u \pm v)}}{2} = \sinh u \cosh v \pm \cosh u \sinh v.$$

$$\cosh(u \pm v) = \frac{e^{u \pm v} + e^{-(u \pm v)}}{2} = \cosh u \cosh v \pm \sinh u \sinh v.$$

$$\tanh(u \pm v) = \frac{e^{u \pm v} - e^{-(u \pm v)}}{e^{u \pm v} + e^{-(u \pm v)}} = \frac{\tanh u \pm \tanh v}{1 \pm \tanh u \tanh v}.$$

$$\sinh 2u = 2 \sinh u \cosh u.$$

$$\cosh 2u = \cosh^2 u + \sinh^2 u.$$

$$\tanh 2u = \frac{2 \tanh u}{1 + \tanh^2 u}.$$

685. If  $x = a \cosh u$  and  $y = a \sinh u$ , the difference between their squares is

$$x^2 - y^2 = a^2 (\cosh^2 u - \sinh^2 u).$$

Since  $\cosh^2 u - \sinh^2 u = 1$ .

Then

$$x^2 - y^2 = a^2.$$

This shows that the hyperbolic functions in the parametric equations,

$$x = a \cosh u \text{ and } y = a \sinh u,$$

have an analogous relation to the rectangular hyperbola  $x^2 - y^2 = a^2$  that the parametric equations  $x = \cos \theta$  and  $y = \sin \theta$

(Art. 805) have to the circle  $x^2 + y^2 = a^2$ . This accounts for the name *hyperbolic functions*.

**686.** If  $\cosh u = \frac{e^u + e^{-u}}{2}$  is added to  $\sinh u = \frac{e^u - e^{-u}}{2}$  then

$$\cosh u + \sinh u = \frac{e^u + e^{-u}}{2} + \frac{e^u - e^{-u}}{2}, \text{ or}$$

$$e^u = \cosh u + \sinh u.$$

If  $\sinh u = \frac{e^u - e^{-u}}{2}$  is subtracted from  $\cosh u = \frac{e^u + e^{-u}}{2}$  then

$$e^{-u} = \cosh u - \sinh u.$$

**687. Relations between the Trigonometric and Hyperbolic Functions.**—If in (4) of Art. 681 we substitute  $i\theta$  for  $\theta$ , then

$$i \sin i\theta = \frac{1}{2}[e^{i(i\theta)} - e^{-i(i\theta)}] = -\frac{1}{2}(e^\theta - e^{-\theta}) = -\sinh \theta.$$

$$\therefore \sin i\theta = i \sinh \theta.$$

Likewise, if in (5) of Art. 681 we substitute  $i\theta$  for  $\theta$ , then

$$\cos i\theta = \frac{1}{2}[e^{i(i\theta)} + e^{-i(i\theta)}] = \frac{1}{2}(e^\theta + e^{-\theta}) = \cosh \theta.$$

$$\therefore \cos i\theta = \cosh \theta.$$

Dividing  $\sin i\theta$  by  $\cos i\theta$ , then

$$\tan i\theta = i \tanh \theta.$$

**688. Expressions of  $\sinh x$  and  $\cosh x$  in a Series.**—From

$$\sinh x = \frac{1}{2}(e^x - e^{-x}) \text{ [323] and}$$

$$e^x = 1 + x + \frac{x^2}{2} + \frac{x^3}{3} + \frac{x^4}{4} + \dots \quad (\text{Art. 463})$$

$$\begin{aligned} \sinh x &= \frac{1}{2} \left[ \left( 1 + x + \frac{x^2}{2} + \frac{x^3}{3} + \dots \right) - \left( 1 - x + \frac{x^2}{3} - \frac{x^3}{5} + \dots \right) \right] \\ &= \frac{1}{2} \left( 2x + \frac{2x^3}{3} + \frac{2x^5}{5} + \dots \right) = x + \frac{x^3}{3} + \frac{x^5}{5} + \dots \\ \therefore \sinh x &= x + \frac{x^3}{3} + \frac{x^5}{5} + \dots \end{aligned}$$

In a similar manner it may be shown that

$$\cosh x = 1 + \frac{x^2}{2} + \frac{x^4}{4} + \frac{x^6}{6} + \dots$$

The above series for  $\sinh x$  and  $\cosh x$  are convergent for all real values of  $x$  and may be used for computing the hyperbolic functions of  $x$ .

689. Graphs of Hyperbolic Functions.

$$\sinh x = \frac{e^x - e^{-x}}{2}.$$

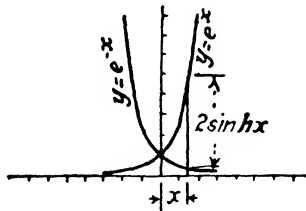

FIG. 347.

$$\cosh x = \frac{e^x + e^{-x}}{2}.$$

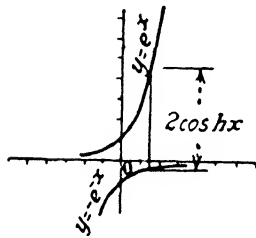

FIG. 348.

## CHAPTER XXIX

### SOLUTION OF TRIGONOMETRIC EQUATIONS

**690.** The solution of Trigonometric Equations may be divided into three parts:

1. Express all the trigonometric ratios occurring in the equation in terms of a single ratio of a single angle.
2. Solve the equation resulting from (1) as an algebraic equation.
3. Determine all the angles corresponding to the values of the function found in (2).

EXAMPLE.—Given  $\tan 2\theta = \frac{24}{7}$ .

$$\frac{2 \tan \theta}{1 - \tan^2 \theta} = \frac{24}{7}$$

$$12 \tan^2 \theta + 7 \tan \theta - 12 = 0.$$

Solving as a quadratic,

$$\tan \theta = -\frac{4}{3}, \text{ or } \frac{3}{4} = -1.33, \text{ or } .75. \quad \theta = 126.9^\circ, \text{ or } 36.9^\circ.$$

EXAMPLE.—Given  $\cos \theta + \sin \theta = 1.25$ . To find  $\theta$ .

Express  $\cos \theta$  in terms of  $\sin \theta$  by formula,

$$\cos \theta = \sqrt{1 - \sin^2 \theta} \quad [273].$$

Substituting,

$$\sin \theta + \sqrt{1 - \sin^2 \theta} = 1.25, \text{ or}$$

$$\sqrt{1 - \sin^2 \theta} = 1.25 - \sin \theta.$$

Squaring both sides,

$$1 - \sin^2 \theta = 1.562 - 2.5 \sin \theta + \sin^2 \theta.$$

$$2 \sin^2 \theta - 2.5 \sin \theta = -.562.$$

$$\sin^2 \theta - 1.25 \sin \theta = -.281.$$

Solving the quadratic,

$$\sin \theta = .95 \text{ or } .294.$$

$$\theta = 72^\circ 53' \text{ or } 17^\circ 7'.$$

EXAMPLE.—Given  $\tan \theta \cdot \tan 2\theta + \cot \theta + 2 = 0$ .

Use

$$\tan 2\theta = \frac{2 \tan \theta}{1 - \tan^2 \theta}, \quad [292] \quad \text{and} \quad \cot \theta = \frac{1}{\tan \theta} \quad [275].$$

Substituting in the above equation, clearing of fractions and collecting terms, we have

$$\tan^2 \theta - 2 \tan \theta - 1 = 0,$$

from which

$$\tan \theta = 1 \pm \sqrt{2} = 2.4142, \text{ or } -.4142.$$

$$\theta = 67^\circ 30', \text{ or } -22^\circ 30'.$$

EXAMPLE.—Given  $\tan^{-1}(x + 1) + \tan^{-1}(x - 1) = \tan^{-1} 2$ .

To find  $x$ .

Let  $\theta = \tan^{-1}(x + 1)$ ; then  $\tan \theta = x + 1$ .

$\beta = \tan^{-1}(x - 1)$ ; then  $\tan \beta = x - 1$ .

Using

$$\begin{aligned} \tan(\theta + \beta) &= \frac{\tan \theta + \tan \beta}{1 - \tan \theta \tan \beta} \quad [280], \\ &= \frac{x + 1 + x - 1}{1 - (x + 1)(x - 1)} = \frac{2x}{2 - x^2}, \end{aligned}$$

then

$$\theta + \beta = \tan^{-1} \frac{2x}{2 - x^2} = \tan^{-1} 2, \text{ or}$$

$$\frac{2x}{2 - x^2} = 2, \text{ whence}$$

$$x^2 + x - 2 = 0.$$

Solving quadratic,

$$x = -2, \text{ or } 1.$$

**691. Equations of the form,**

$$\sin(x + B) = c \sin x,$$

where  $\angle B$  and the constant  $c$  are known, can be reduced to

$$\tan\left(x + \frac{B}{2}\right) = \frac{c + 1}{c - 1} \tan \frac{B}{2},$$

from which  $\tan x$  and then  $x$  can be found.

**692. Equations of the form,**

$$\tan(x + B) = c \tan x,$$

where  $\angle B$  and the constant  $c$  are known, can be reduced to

$$\sin(2x + B) = \frac{c + 1}{c - 1} \sin B,$$

from which  $\sin(2x + B)$  and then  $x$  can be found.

**693. Equations of the form,**

$$a \cos n\theta + b \sin n\theta = c,$$

can be reduced to

$$\theta = \frac{1}{n} \left[ \tan^{-1} \frac{a}{b} + \sin^{-1} \frac{c}{\sqrt{a^2 + b^2}} \right],$$

provided  $|c| \leq \sqrt{a^2 + b^2}$ .

The sign of the radical is to be taken the same as the sign of  $b$ .

## 694. Graphical Solutions of Trigonometric Equations.

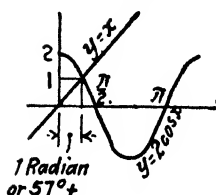

FIG. 349.

EXAMPLE.— $2 \cos x = x$ . To find  $x$  (in radians) for which this relation holds.

Draw the curves,

$$y = 2 \cos x \text{ and } y = x.$$

The abscissae of each point of intersection is a root of the equation.

695. The equation  $R \sin(x + c) = a \cos x + b \sin x$  is true for certain values of  $C$  and  $R$ .

Draw any angle,  $x = \angle XON$ , in the first quadrant and the constant angle,  $c = \angle NOP$ , with  $OP = R$  and  $NP$  perpendicular to  $ON$ . Let  $PN = a$  and  $NO = b$ . Draw  $PS$  and  $NQ$  parallel to the  $Y$ -axis and  $MN$  parallel to the  $X$ -axis.

Then

$$PM = a \cos x \text{ and } MS = NQ = b \sin x.$$

$$PM + MS = PS = R \sin(x + c) = a \cos x + b \sin x.$$

In the same manner it may be shown that the above holds true when  $x$  lies in the other quadrants or has any value whatever. From the figure,

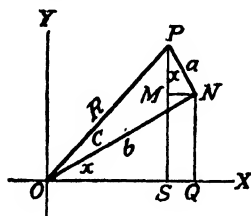

FIG. 350.

$$\tan c = \frac{a}{b}, \text{ or } c = \tan^{-1} \frac{a}{b}, \text{ and } R = \sqrt{a^2 + b^2}.$$

696. Graphs of the form,  $y = a \cos x + b \sin x$ , can be constructed by finding the  $c$  and  $R$  from the above formulae and constructing the graph of  $y = R \sin(x + c)$ , as in Art. 619, which is much easier to make than  $y = a \cos x + b \sin x$ .

EXAMPLE.—Construct the graph of  $y = \cos x - \sqrt{3} \sin x + 1$ .

$$a = 1, b = -\sqrt{3}, \tan c = \frac{1}{\sqrt{3}}, c = -30^\circ = -\frac{\pi}{6}.$$

$$R = \sqrt{1 + 3} = 2.$$

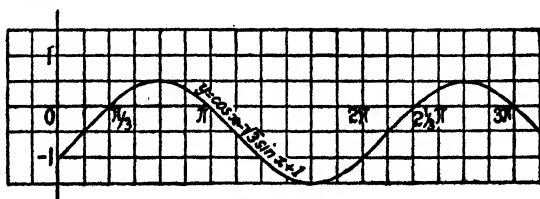

FIG. 351.



We, therefore, draw the graph of  $y = 2 \sin \left( x - \frac{\pi}{6} \right) + 1$  or make the graph of  $y = 2 \sin \left( x - \frac{\pi}{6} \right)$  and raise the origin 1 unit.

697. EXAMPLE 1.—Draw the graph of  $y = \sin 2x + \sin x + \frac{1}{2}$ .

Draw the graph of  $y = \sin 2x$  and  $y = \sin x$  on the same axes, with  $x$  expressed in radians, and then add  $\frac{1}{2}$  to the sum of the ordinates of these graphs. The new graph will be that of

$$y = \sin 2x + \sin x + \frac{1}{2},$$

as shown in Fig. 352.

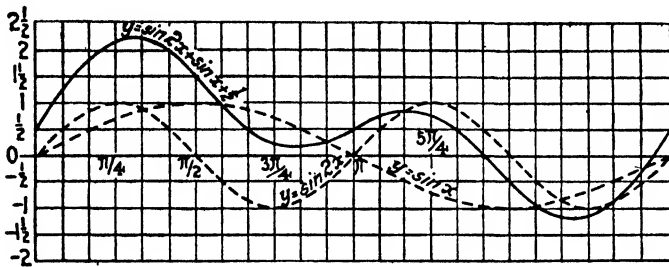

FIG. 352.

EXAMPLE 2.—Draw the graph of  $y = \sin 5x - \sin 3x + \sin x$ .

Draw the graphs of  $y_1 = \sin 5x$ ,  $y_2 = \sin 3x$ , and  $y_3 = \sin x$  on the same axes, with  $x$  expressed in radians, and then take the algebraic sum of the ordinates of these graphs for the ordinates of the new graph, which is constructed as shown in Fig. 353.

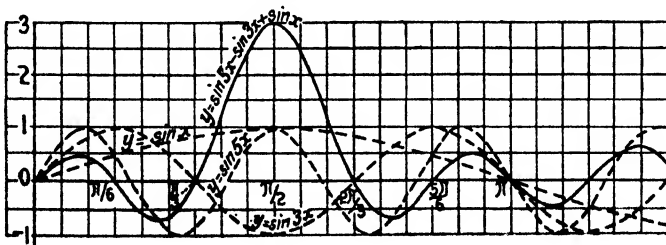

FIG. 353.

698. Simultaneous Trigonometric Equations.—A few examples with graphical solutions will be given.

EXAMPLE 1.—Solve graphically the simultaneous equations,

$$\begin{aligned} y &= 1 - \cos x \text{ and} \\ y &= 1 + \sin x. \end{aligned}$$

The graphs are constructed and their intersections determine the values of the unknown which satisfy both equations. The values of  $x$  are

$$x = n\pi + \frac{3}{4}\pi,$$

where  $n$  is any integer.

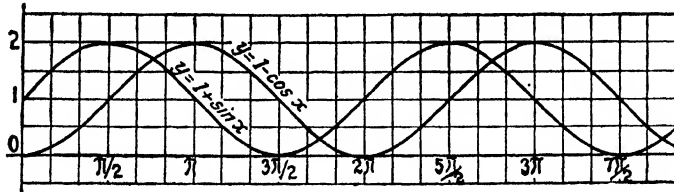

FIG. 354.

EXAMPLE 2.—Solve graphically the simultaneous equations,

$$y = 3 \sin \theta + 2 \cos \theta \quad (1)$$

$$y = 3 \cos \theta + 2 \sin \theta. \quad (2)$$

From Arts. 695, 696 these equations can be changed to the form,  $y = R \sin(\theta + c)$ .

In equation (1),  $a = 2$  and  $b = 3$ ,  $\tan c = \frac{2}{3}$ ,  $c = 33.7^\circ$ .

$$R = \sqrt{a^2 + b^2} = \sqrt{13} = 3.6.$$

Equation (1) becomes  $y = 3.6 \sin(\theta + 33.7^\circ)$ .

In the same manner in equation (2),  $a = 3$ ,  $b = 2$ ,  $\tan c = \frac{3}{2}$ .

$$c = 56.3^\circ \text{ and } R = \sqrt{13} = 3.6.$$

Equation (2) becomes  $y = 3.6 \sin(\theta + 56.3^\circ)$ .

From the graphs (Fig. 355),

$$\theta = n\pi + \frac{\pi}{4}$$

$n$  being any integer.

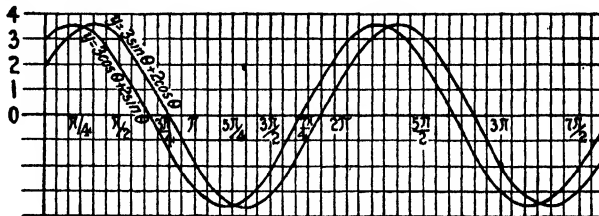

FIG. 355.

699. In many cases the graphical method of solving simultaneous trigonometric equations is the only practical method of solution, as the following example will indicate:

EXAMPLE 3.—Solve graphically the simultaneous equations,

$$y = \sin 2x + \sin x + \frac{1}{2} \text{ and}$$

$$y = \sin 5x - \sin 3x + \sin x.$$

The graphs of these equations are constructed as shown in Art. 697. The intersections show the values of the unknown which satisfy both equations.

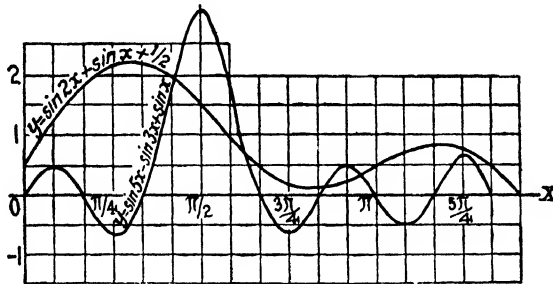

FIG. 356.

## CHAPTER XXX

### SIMPLE APPLICATIONS OF COORDINATES

700. The application of algebraic methods to the solution of geometric and trigonometric problems is called analytical geometry.

701. **Values of Line Segments.**—The length of a line is determined by the number of units traversed by the point that generates it.

A line segment read in one direction is the negative of the same line segment read in the opposite direction. Thus,  $P_1P_2 = -P_2P_1$ . Then  $P_1P_2 + P_2P_1 = 0$ .

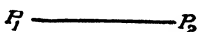

FIG. 357.

The laws for the addition and subtraction of line segments are the same as those which govern the addition and subtraction of algebraic quantities.

For convenience, we designate the direction to the right on a horizontal line as positive and to the left as negative.

The line segment between the initial point and the terminal point determines the sum of the positive and negative line segments. In the following figure, the tracing has been done over parallel segments instead of over the same line to avoid confusion. Thus,

$$AC + CB + BD + DE + EC = AC.$$

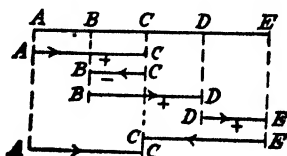

FIG. 358.

The sum is either  $-CA$  or  $+AC$ .

EXAMPLE.

$$AB - CB + CD = AD.$$

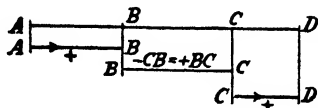

FIG. 359.

The value of the sum of the line segments is  $AD$ , for  $AD$  is a segment from the initial point to the terminal point.

**702. Geometry of one dimension** is restricted to a line. The point is the elementary conception. Position is given by one variable, which indicates the position of a point in that line. Any algebraic equation in that variable represents one or more points.

**703. Geometry of Two Dimensions.**—The point may be taken as the fundamental element. Position is given by two variables referred to two fixed lines, called axes, in a plane. Any algebraic equation in two variables represents a curve, or locus, whose generating point moves so as to satisfy some condition or law.

**704. Coordinates.**—Rectangular coordinates, principally, are used in analytical geometry although it is often convenient to use oblique or polar coordinates.

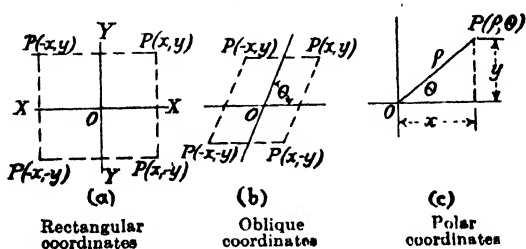

FIG. 380.

The relation of rectangular coordinates  $(x, y)$  to polar coordinates  $(p, \theta)$  has been shown to be (see Art. 655),

$$x = p \cos \theta \quad [313].$$

$$p = \sqrt{x^2 + y^2} \quad [316].$$

$$y = p \sin \theta \quad [314].$$

$$\theta = \tan^{-1} \frac{y}{x} \quad [315].$$

The polar form locates a point in a plane just as definitely as the rectangular coordinates by the distance from the origin or pole ( $\rho$ , called the *radius vector*), and the direction which the radius vector makes with the X-axis ( $\theta$ , called the *vectorial angle*).

We have seen that we can change from rectangular coordinates to polar coordinates by substituting  $\rho \cos \theta$  for  $x$  and  $\rho \sin \theta$  for  $y$  in the rectangular equation of the locus, or from polar coordinates to rectangular coordinates by substituting  $x$  for  $\rho \cos \theta$  and  $y$  for  $\rho \sin \theta$  in the polar equation of the locus.

Substituting

$$\sqrt{x^2 + y^2} \text{ for } \rho, \text{ and } \frac{y}{x} \text{ for } \tan \theta$$

in the polar equation sometimes conveniently effects the transformation from polar to rectangular coordinates.

705. In the case where the origins are located at different points,

$$[323] \quad x = a + \rho \cos \theta.$$

$$[324] \quad y = b + \rho \sin \theta.$$

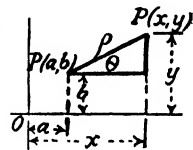

FIG. 361.

706. If the polar axis makes an angle  $\varphi$  with the X-axis, but the origins are at the same point, then

$$[325] \quad x = \rho \cos (\theta + \varphi).$$

$$[326] \quad y = \rho \sin (\theta + \varphi).$$

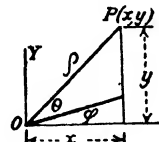

FIG. 362.

707. If the origin is translated to the point ( $a$ ,  $b$ ) in the above case,

$$[327] \quad x = a + \rho \cos (\theta + \varphi).$$

$$[328] \quad y = b + \rho \sin (\theta + \varphi).$$

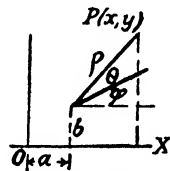

FIG. 363.

708. Distance between two points, as  $A (x_2, y_2)$  and  $B (x_1, y_1)$  (Fig. 364).

From the triangle  $ABC$

$$\overline{AB}^2 = \overline{AC}^2 + \overline{BC}^2.$$

Putting this geometrical relation in terms of the coordinates,

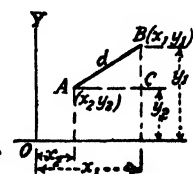

FIG. 364.

$$[329] \quad d = \sqrt{(x_1 - x_2)^2 + (y_1 - y_2)^2},$$

where  $d$  is the distance between the points  $A$  and  $B$ .

709. Using Oblique Axes.—From the law of cosines (Art. 642),

$$[330] \quad c^2 = a^2 + b^2 - 2ab \cos C,$$

we have

$$AB^2 = AC^2 + BC^2 - 2(AC)(BC) \cos(180^\circ - \varphi).$$

But

$$\cos(180^\circ - \varphi) = -\cos \varphi.$$

Therefore, putting the trigonometric relation into terms of the coordinates,

$$d^2 = (x_1 - x_2)^2 + (y_1 - y_2)^2 + 2(x_1 - x_2)(y_1 - y_2) \cos \varphi$$

and

$$[331] \quad d = \sqrt{(x_1 - x_2)^2 + (y_1 - y_2)^2 + 2(x_1 - x_2)(y_1 - y_2) \cos \varphi}.$$

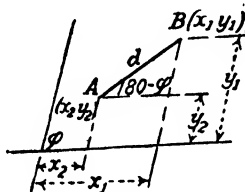

FIG. 365.

710. Using polar coordinates, the points are  $A(\rho_1, \theta_1)$  and  $B(\rho_2, \theta_2)$ .

$$[332] \quad d = \sqrt{\rho_1^2 + \rho_2^2 - 2\rho_1\rho_2 \cos(\theta_2 - \theta_1)}.$$

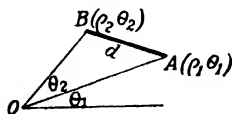

FIG. 366.

EXAMPLE 1.—Find the distance between the points  $(4, -5)$  and  $(-3, 6)$  rectangular coordinates.

Substituting in

$$\begin{aligned} d &= \sqrt{(x_1 - x_2)^2 + (y_1 - y_2)^2}, \\ d &= \sqrt{[4 - (-3)]^2 + [-5 - (+6)]^2} = \\ &= \sqrt{(7)^2 + (11)^2} = \sqrt{170}. \end{aligned}$$

EXAMPLE 2.—Find the length of the side  $l$  of the given triangle by means of analytical geometry, using oblique axes.

Given two sides and the included angle,

$$OA = 3.$$

$$OB = 5.$$

$$\theta = 53.2^\circ.$$

Assume two sides of the triangle as axes of coordinates, using

$$d = \sqrt{(x_1 - x_2)^2 + (y_1 - y_2)^2 + 2(x_1 - x_2)(y_1 - y_2) \cos \theta}.$$

Then

$$d = \sqrt{(5 - 0)^2 + (0 - 3)^2 + 2(5 - 0)(0 - 3) \cdot 6} = \sqrt{25 + 9 - 18} = \sqrt{16} = 4.$$

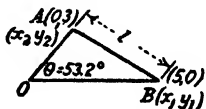

FIG. 367.

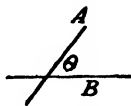

FIG. 368.

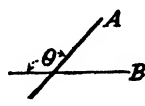

FIG. 369.

**711. Angular Measurements between Lines.**—Positive angular measure is taken counterclockwise between two lines and is less than  $180^\circ$ . In Fig. 368, the angle which  $A$  makes with  $B$  is the angle starting at  $B$  and measured counterclockwise.

The angle that  $B$  makes with  $A$  is measured by starting at  $A$  and measuring the angle to  $B$  as in Fig. 369.

The angle measured in the second case is the supplement of the first angle, or the angle that  $A$  makes with  $B$  is the supplement of the angle that  $B$  makes with  $A$ .

**712. Slope or Inclination of Lines.**—In rectangular coordinates, the *slope* or *gradient* of a line is the ratio of the change in the ordinate to the corresponding change in the abscissa of a point moving along the locus.

The slope is positive if the ordinate increases as the abscissa increases and negative if the ordinate decreases as the abscissa increases.

The slope, since it is the ratio of the change in the ordinate to the corresponding change in the abscissa, is  $\tan \theta$ , where  $\theta$  is the angle which the line makes with the  $X$ -axis.

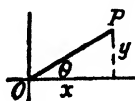

FIG. 370.

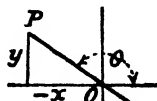

FIG. 371.

Let  $m = \text{slope} = \tan \theta$ .



**713. The Slope of a Line through Two Points  $P_1(x_1, y_1)$  and  $P_2(x_2, y_2)$  in Terms of the Coordinates.**—If  $m$  is the slope, then

$$[333] \quad m = \frac{y_1 - y_2}{x_1 - x_2}.$$

Note that the slope is given in terms of the coordinates of the two points.

In the case where a line is parallel to the  $Y$ -axis, we cannot speak of its slope since the change in ordinate corresponding to a change in abscissa means nothing. The notation

$$m = \infty$$

means simply that the line is parallel to the  $Y$ -axis and its slope is not defined.

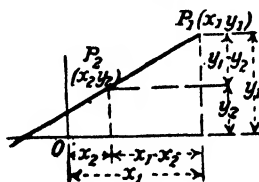

FIG. 372.

**714. Parallel Lines.**—If two lines are parallel, then  $\theta_1$  and  $\theta_2$  are equal, whence the slopes are equal, or

$$m_1 = m_2.$$

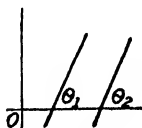

FIG. 373.

**715. Perpendicular Lines.**—Assuming the lines perpendicular, then

$$\theta_2 = \theta_1 + \frac{\pi}{2},$$

whence

$$[334] \quad \tan \theta_2 = -\cot \theta_1 = -\frac{1}{\tan \theta_1},$$

or

$$[335] \quad m_2 = -\frac{1}{m_1}.$$

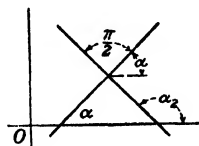

FIG. 374.

Two lines are perpendicular if their slopes are negative reciprocals.

**716. The Angle One Line Makes with Another.**—Let  $\beta$  be the angle  $l_2$  makes with  $l_1$ .

Then

$$\theta_2 = \theta_1 + \beta, \text{ or } \beta = \theta_2 - \theta_1,$$

whence, by trigonometry,

$$\tan \beta = \frac{\tan \theta_2 - \tan \theta_1}{1 + \tan \theta_1 \cdot \tan \theta_2} \quad [280] = \frac{m_2 - m_1}{1 + m_2 m_1},$$

and

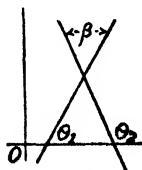

FIG. 375.

$$[336] \quad \beta = \tan^{-1} \frac{m_2 - m_1}{1 + m_2 m_1}.$$

If, however,  $\beta'$  is the angle which  $l_1$  makes with  $l_2$ ,  $\beta' = 180^\circ - \beta$ ,  $\tan \beta' = -\tan \beta$  (Art. 603), and hence,

$$\tan \beta' = \frac{m_1 - m_2}{1 + m_2 m_1}.$$

EXAMPLE.—Find the angle between the lines joining (5, 0) to (6,  $\sqrt{3}$ ) and (0, 0) to ( $-\sqrt{3}$ , -5).

Let  $m_1$  = slope of the first line =  $\frac{0 - \sqrt{3}}{5 - 6} = \sqrt{3}$ . [333]

$m_2$  = slope of the second line =  $\frac{0 + 5}{0 + \sqrt{3}} = \frac{5}{\sqrt{3}}$ .

Substituting in above,  $m_2$  has the greater slope; then

$$\beta = \tan^{-1} \frac{\frac{5}{\sqrt{3}} - \sqrt{3}}{1 + \frac{5}{\sqrt{3}} \cdot \frac{\sqrt{3}}{1}} = \frac{2}{\frac{6}{1}} = 10^\circ 50'.$$

717. Dividing a Line Segment in a Given Ratio.—Let  $P_1$  and  $P_2$  be two fixed points on a line.

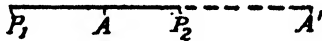

FIG. 376.

A point, as  $A$ , divides the segment *internally* if it lies on the line between  $P_1$  and  $P_2$ , and *externally* if it lies outside of  $P_1$  and  $P_2$ .

The position of the point of division depends upon the ratio of its distances from  $P_1$  and  $P_2$ . If the line has a positive direction, the conventional way is to consider the point  $A$  as dividing the line into segments  $P_1A$  and  $AP_2$ , and the ratio of division is

$$\frac{P_1A}{AP_2}.$$

For internal division, both segments are read in the same direction as  $P_1P_2$ , thus,

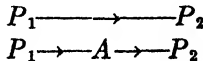

For external division, the ratio is

$$\frac{P_1A'}{A'P_2}$$

in all cases. Either  $P_1A'$  is positive and  $A'P_2$  is negative, or  $P_1A'$  is negative and  $A'P_2$  is positive, and, therefore, the ratio is negative in both cases.



If  $P_1A'$  is positive and  $A'P_2$  is negative, then

$$\frac{P_1A'}{A'P_2} > 1.$$

If  $P_1A'$  is negative and  $A'P_2$  is positive, then

$$\frac{P_1A'}{A'P_2} < 1.$$

**718. To Divide the Line Joining Two Points  $(x_1, y_1)$  and  $(x_2, y_2)$  in a Given Ratio  $r$ .**— $A(x_1, y_1)$  and  $B(x_2, y_2)$  are the given points and  $C(x, y)$  is the required point of division.

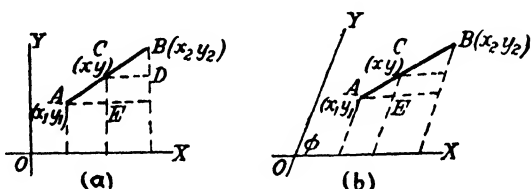

FIG. 377.

By similar triangles

$$\frac{AE}{CD} = \frac{AC}{CB} = r.$$

Then

$$\frac{x - x_1}{x_2 - x} = r \text{ and } x = \frac{x_1 + rx_2}{1 + r}.$$

Likewise,

$$\frac{EC}{DB} = r = \frac{y - y_1}{y_2 - y} \text{ and } y = \frac{y_1 + ry_2}{1 + r}.$$

If  $C(x, y)$  is between  $A$  and  $B$ , then  $r$  may have any positive value.

If  $C$  is on the line produced through  $A$ , then  $r$  is negative and numerically less than 1.

If  $C$  is on the line produced through  $B$ , then  $r$  is negative and numerically greater than 1.

Whether the ratio is such to divide the line externally or internally, the coordinates of the point of division for that particular ratio are

$$x = \frac{x_1 + rx_2}{1+r} \text{ and } y = \frac{y_1 + ry_2}{1+r}.$$

To find the midpoint of a line segment, the ratio  $r$  is equal to 1, and the above formulae become

$$x = \frac{x_1 + x_2}{2} \text{ and } y = \frac{y_1 + y_2}{2}$$

**719. Area of a Triangle.**—Area  $\triangle ABC = \triangle ABD + \triangle BCD + \triangle ADC$ . Since the area of a triangle equals one-half the product of its base by its altitude, then

$$\text{Area } \triangle ABD = \frac{BD \times BE}{2} = \frac{1}{2} (x_2 - x_3)(y_2 - y_1).$$

$$\text{Area } \triangle BCD = \frac{BD \times CD}{2} = \frac{1}{2} (x_2 - x_3)(y_3 - y_2).$$

$$\text{Area } \triangle ADC = \frac{AF \times CD}{2} = \frac{1}{2} (x_3 - x_1)(y_3 - y_2).$$

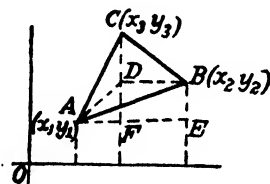

FIG. 378.

Area  $\triangle ABC = \frac{1}{2}[(x_2 - x_3)(y_2 - y_1) + (x_2 - x_3)(y_3 - y_2) + (x_3 - x_1)(y_3 - y_2)]$ , which reduces to

$$[337] \triangle ABC = \frac{1}{2}[x_1y_2 + x_2y_3 + x_3y_1 - y_1x_2 - y_2x_3 - y_3x_1].$$

**720.** A very good rule to follow is to write down in a column the abscissae of the vertices taken in a counterclockwise order.

Start a second column of the ordinates but begin the column with the ordinate of the second vertex and follow the third ordinate with the ordinate of the first vertex.

Place a plus sign before each product, as shown.

Start a third column using the ordinates and writing them in the same order as the abscissae of the first column. Then

place next to this a fourth column composed of the abscissae beginning with the second and following the third by the first as was done in the second column. Place a minus sign before each of these products.

Then

$$x_1y_2 + x_2y_3 + x_3y_1 - y_1x_2 - y_2x_3 - y_3x_1$$

is the result of adding the products.

**721. Determinant Form for the Area of Any Triangle.**— Assuming that the vertices are at the points  $(x_1, y_1)$ ,  $(x_2, y_2)$ , and  $(x_3, y_3)$ , the determinant is written thus,

$$A = \frac{1}{2} \begin{vmatrix} x_1 & y_1 & 1 \\ x_2 & y_2 & 1 \\ x_3 & y_3 & 1 \end{vmatrix}$$

Expanding this according to the rule for determinants, by adding the three products formed from the elements lying on the lines pointing to the left and subtracting the three products formed from the elements pointing to the right there results the expression,

$$x_1y_2 + x_2y_3 + x_3y_1 - y_1x_2 - y_2x_3 - y_3x_1.$$

**722.** If the origin is at one of the vertices, as  $(x_3, y_3)$ , then the point  $(x_3, y_3)$  becomes  $(0, 0)$ , and substituting in

[338]  $A = \frac{1}{2}[x_1y_2 + x_2y_3 + x_3y_1 - y_1x_2 - y_2x_3 - y_3x_1]$

gives

$$A = \frac{1}{2}[x_1y_2 + 0 + 0 - y_1x_2 - 0 - 0] = \frac{1}{2}[x_1y_2 - y_1x_2].$$

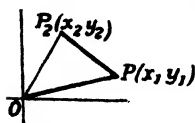

FIG. 380.

The determinant form is very convenient to remember, for  $x_1y_2 - y_1x_2$  in the determinant form is

$$x_1 y_1 \quad \text{and then } A = \frac{1}{2} \begin{vmatrix} x_1 & y_1 \\ x_2 & y_2 \end{vmatrix}$$

**EXAMPLE.**—Find the area of the triangle formed by the origin and the pair of points  $(4, 3)$  and  $(2, 5)$ .

$$A = \frac{1}{2} \begin{vmatrix} 4 & 3 \\ 2 & 5 \end{vmatrix} = \frac{1}{2}(4 \times 5 - 2 \times 3) = 7.$$



FIG. 379.

**723. Area of a Polygon.**—A polygon which has its vertices given in rectangular coordinates can be divided into triangles by drawing the diagonals. Its area can then be found by the same general scheme used in finding the area of the triangle.

$$\begin{aligned} &+ x_1y_2 - y_1x_2 \\ &+ x_2y_3 - y_2x_3 \\ &+ x_3y_4 - y_3x_4 \\ &+ x_4y_5 - y_4x_5 \\ &+ x_5y_1 - y_5x_1 \end{aligned}$$

The vertices must be taken in order and counterclockwise, as  $P_1(x_1, y_1)$ ,  $P_2(x_2, y_2)$ ,  $P_3(x_3, y_3)$  etc., and then the same scheme can be used as in the case of the triangle.

For a five-sided polygon, as shown, the area would be

$$A = \frac{1}{2}[x_1y_2 + x_2y_3 + x_3y_4 + x_4y_5 + x_5y_1 - y_1x_2 - y_2x_3 - y_3x_4 - y_4x_5 - y_5x_1].$$

**EXAMPLE.**—Find the area of the polygon shown in Fig. 381.

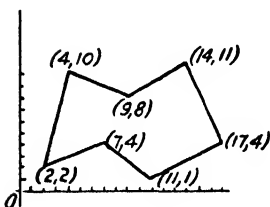

FIG. 381.

$$\begin{aligned} &+ 2 \cdot 4 = 8 \\ &+ 7 \cdot 1 = 7 \\ &+ 11 \cdot 4 = 44 \\ &+ 17 \cdot 11 = 187 \\ &+ 14 \cdot 8 = 112 \\ &+ 9 \cdot 10 = 90 \\ &+ 4 \cdot 2 = 8 \\ &\quad \quad \quad + 456 \\ &- 2 \cdot 7 = 14 \\ &- 4 \cdot 11 = 44 \\ &- 1 \cdot 17 = 17 \\ &- 4 \cdot 14 = 56 \\ &- 11 \cdot 9 = 99 \\ &- 8 \cdot 4 = 32 \\ &- 10 \cdot 2 = 20 \\ &\quad \quad \quad - 282 \end{aligned}$$

Area =  $\frac{1}{2}[456 - 282] = 87$ .

**EXAMPLE.**—Find the area of polygon shown Fig. 382 as an exercise.

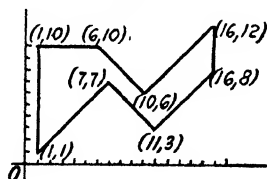

FIG. 382.

**724. Formation of Equations.**—Problems are often given in the form of a geometric or trigonometric relation and in order to

determine the solution or to examine critically and apply the relation as a general case, we put the relation in the form of an equation. A few problems will illustrate.

**PROBLEM.**—A point moves in a plane so that its distances from the points  $(4, -3) P_1$  and  $(-3, 6) P_2$  are equal.

Find the equation of the locus of the point.

Let  $P(x, y)$  be the point.

Our problem is to express the given relation in terms of  $x$  and  $y$ , or the coordinates of the point.

From the relations given,

$$P_1P = P_2P.$$

From Art. 708, the distance between two points, as  $P_1P$ , is

$$\sqrt{(x-4)^2 + (y+3)^2},$$

and also

$$P_2P = \sqrt{(x+3)^2 + (y-6)^2}.$$

Moreover,

$$\sqrt{(x-4)^2 + (y+3)^2} = \sqrt{(x+3)^2 + (y-6)^2}.$$

Squaring both sides and collecting,

$$x^2 - 8x + 16 + y^2 + 6y + 9 = x^2 + 6x + 9 + y^2 - 12y + 36.$$

Or

$$7x - 9y + 20 = 0.$$

**PROBLEM.**—The distance between two points is 8 inches. A point moves so that the sum of its distances from the given points is always equal to 10 inches.

Draw the  $X$ -axis through the two points and the  $Y$ -axis midway between, as shown in Fig. 384.

From the conditions of the problem,

$$P_2P + P_1P = 10 \text{ inches.}$$

Writing this relation in terms of the coordinates, using the distance formula, [329] then

$$\sqrt{(x-4)^2 + (y)^2} + \sqrt{(x+4)^2 + (y)^2} = 10,$$

from which

$$9x^2 + 25y^2 = 225.$$

This locus will be recognized as the ellipse (Art. 200).

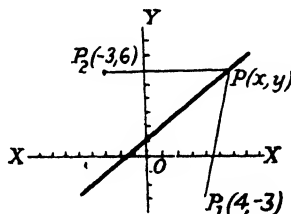

FIG. 383.

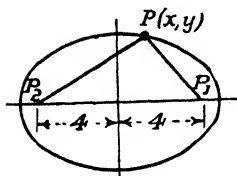

FIG. 384.

PROBLEM.—A point  $P(x, y)$  moves so that the difference of its distances from  $P_2(5, 0)$  and  $P_1(-5, 0)$  is 8. Find the equation of the locus of the point.

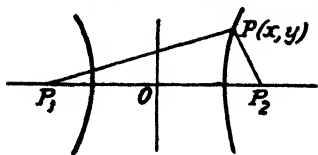

FIG. 385.

From the statement of the problem,

$$P_1P - P_2P = 8.$$

Then

$$\sqrt{(x+5)^2 + y^2} - \sqrt{(x-5)^2 + y^2} = 8.$$

Or

$$9x^2 - 16y^2 = 144.$$

PROBLEM.—Find the equation of the locus of a point whose distance from  $P_1(-2, 2)$  is always equal to 4.

Assume that  $P(x, y)$  is any point on the locus.

From the statement of the problem,

$$P_1P = 4.$$

$$P_1P = \sqrt{(x+2)^2 + (y-2)^2} = 4.$$

Squaring both sides,

$$x^2 + 4x + 4 + y^2 - 4y + 4 = 16.$$

Or

$$x^2 + y^2 + 4x - 4y = 8.$$

This is the equation of the locus. It represents a circle, since the statement of the problem amounts to the definition of a circle.

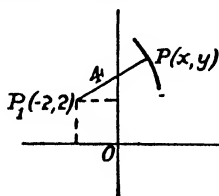

FIG. 386.



## CHAPTER XXXI

### LINEAR EQUATIONS. THE STRAIGHT LINE

#### THE STRAIGHT LINE

**725.** Every equation of first degree in  $x$  and  $y$  represents a straight line (Art. 145).

Two constants must be determined in order to fix the line and to write its equation.

**726. The Slope-point Form.**—If a point in the line and the slope of the line are given, then the line is completely determined.

From Art. 713,

$$m = \frac{y_1 - y_2}{x_1 - x_2} \text{ [333].}$$

If the coordinates of the fixed point  $P_0(x_0, y_0)$  are given and  $P(x, y)$  is any variable point on the line, then

$$m = \frac{y - y_0}{x - x_0},$$

or clearing of fractions,

$$\text{[339] } y - y_0 = m(x - x_0).$$

This equation is the slope-point form of the equation of a straight line in rectangular coordinates.

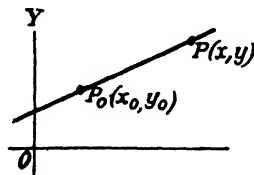

FIG. 387.

**EXAMPLE.**—What is the equation of a line passing through the point (4, 4) and having a slope of 2?

In this case,  $x_0 = 4$ ,  $y_0 = 4$ , and  $m = 2$ .

Substituting in

$$y - y_0 = m(x - x_0) \text{ [339]}$$

gives

$$y - 4 = 2(x - 4),$$

or

$$y = 2x - 4,$$

which is the equation of the line sought.

**EXAMPLE.**—The increase in velocity of a body falling under the action of gravity is proportional to the time. If  $v_0$  is the velocity of the body at the time  $t_0$  and  $v$  is the velocity of the body at any time  $t$ , then

$$v - v_0 = k(t - t_0).$$

If  $v$  and  $v_0$  are given in feet per second and  $t$  and  $t_0$  in seconds, then  $k$ , the proportionality factor, is the constant  $g = 32.2$ .

**EXAMPLE.**—The expansion of a bar of steel is nearly proportional to its increase in temperature. If  $l_0$  is the length of the bar at some temperature  $t_0$  and  $l$  its length at any temperature  $t$ , then

$$l - l_0 = k(t - t_0).$$

**727. Slope-intercept Form.**—If the intercept of a line with the  $Y$ -axis and the slope of the line are given, the line is determined and its equation may be written in the slope-intercept form.

From the point-slope form (Art. 726),

$$y - y_0 = m(x - x_0).$$

But the given point in this case is  $(0, b)$ . Then

$$x_0 = 0, \text{ and } y_0 = b.$$

Substituting in the equation above,

$$y - b = m(x - 0).$$

Or

$$y = mx + b \text{ (Art. 128),}$$

which is the equation of the line in what is called the slope-intercept form.

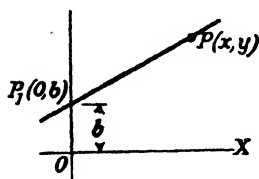

FIG. 388.

**EXAMPLE.**—What is the equation of the straight line which crosses the  $Y$ -axis at  $-3$  and has a slope of  $3$ ?

Here,  $b = -3$  and  $m = 3$ .

Substituting in

$$y = mx + b$$

gives

$$y = 3x - 3,$$

which is the desired equation (see Art. 128).

**EXAMPLE.**—Hooke's law states that the extension of an elastic string varies directly as the tension. If  $l_0$  is the length of the string when the tension is zero, and  $l$  is the length under the tension  $t$ , then

$$l = kt + l_0.$$

**EXAMPLE.**—If a falling body has a velocity of  $v_0$  feet per second when  $t = 0$ , and the velocity varies in proportion to time, then

$$v = kt + v_0.$$

Since the rate of change of velocity with respect to time is denoted by the familiar letter  $g$ , then

$$v = gt + v_0.$$

A discussion of the general equation of first degree,  $Ax + By + C = 0$ , was introduced in a previous section (Art. 145) in order to show the relations existing between the graph and the equation and to give a more comprehensive view of the algebra. We will repeat some of this discussion in this section so that further developments may be made.

If  $B \neq 0$ , we may solve the equation for  $y$ ,

$$y = -\frac{A}{B}x - \frac{C}{B}.$$

Comparing this form with the slope-intercept form,

$$y = mx + b,$$

we readily see that

$$m = -\frac{A}{B}, \text{ and } b = -\frac{C}{B}.$$

By putting the general equation in this form, the slope and the  $Y$ -intercept are readily found.

**728. Lines Parallel to Axes.**—If a line is parallel to the  $X$ -axis, the slope  $m$  equals zero.

Substituting  $m = 0$  in  $y = mx + b$ ,

$$y = 0 \times x + b.$$

Or

$$y = b.$$

It will be seen from this that all points on the line have equal ordinates, *i.e.*,  $b$ .

A line parallel to the  $Y$ -axis cannot be put into the form,  $y = mx + b$ , since  $m$  is undefined for such a line. We, therefore, interchange  $x$  and  $y$  and refer to the  $Y$ -axis. The equation then becomes

$$x = my + b.$$

But referring to the  $Y$ -axis,  $m = 0$ , and

$$x = 0 \times y + b.$$

Or

$$x = b.$$

In case  $b = 0$  in these equations, then  $y = 0$  and  $x = 0$ , which are the equations of the  $X$ - and the  $Y$ -axes, respectively.

**729. Two-point Form.**—If two points in the line are given, the line is determined and its equation may be written.

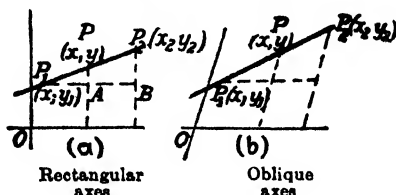

FIG. 389.

Let  $P(x, y)$  be any point on the line.

Draw ordinates and parallels to the  $X$ -axis as shown in Fig. 389.

Then, by similar triangles,

$$\frac{PA}{AP_1} = \frac{P_2B}{P_1B}$$

Or

$$[340] \quad \frac{y - y_1}{x - x_1} = \frac{y_2 - y_1}{x_2 - x_1} = \frac{y_1 - y_2}{x_1 - x_2}$$

Or

$$[341] \quad y - y_1 = \frac{y_2 - y_1}{x_2 - x_1}(x - x_1),$$

which is the two-point form of the equation of a straight line passing through the two points  $P_1(x_1, y_1)$  and  $P_2(x_2, y_2)$ , in terms of the coordinates of the points.

**EXAMPLE.**—What is the equation of the straight line passing through the points (2, 3) and (6, 6)?

Let  $P_2(x_2, y_2) = (6, 6)$ . Then  $x_2 = 6$  and  $y_2 = 6$ .

Let  $P_1(x_1, y_1) = (2, 3)$ . Then  $x_1 = 2$  and  $y_1 = 3$ .

Substituting in

$$\frac{y - y_1}{x - x_1} = \frac{y_2 - y_1}{x_2 - x_1}$$

gives

$$\frac{y - 3}{x - 2} = \frac{6 - 3}{6 - 2}, \text{ or } 4y - 12 = 3x - 6.$$

$\therefore 4y - 3x = 6$  is the equation sought.

The determinant form of the equation of a straight line through the points  $P_1(x_1, y_1)$  and  $P_2(x_2, y_2)$  is

$$\begin{vmatrix} x & y & 1 \\ x_1 & y_1 & 1 \\ x_2 & y_2 & 1 \end{vmatrix} = 0,$$

which is very easy to remember.

$$\begin{vmatrix} x & y & 1 \\ x_1 & y_1 & 1 \\ x_2 & y_2 & 1 \end{vmatrix} = xy_1 + x_1y_2 + x_2y - y_1x_2 - y_2x - x_1y.$$

Add and subtract  $x_1y_1$  which does not change the value. Then

$$xy_1 + x_1y_2 + x_2y - y_1x_2 - y_2x - x_1y + x_1y_1 - x_1y_1 = 0.$$

Collecting like terms,

$$x_2(y - y_1) - x_1(y - y_1) + x(y_1 - y_2) - x_1(y_1 - y_2) = 0.$$

$$(x_2 - x_1)(y - y_1) + (x - x_1)(y_1 - y_2) = 0.$$

Or

$$(x_2 - x_1)(y - y_1) = (x - x_1)(y_2 - y_1).$$

Dividing through by  $(x_2 - x_1)(x - x_1)$  and canceling like terms,

$$\frac{y - y_1}{x - x_1} = \frac{y_2 - y_1}{x_2 - x_1},$$

which is the two-point form given in [340].

**730. The Intercept Form.**—If the intercepts on the  $X$ - and  $Y$ -axes are given, the equation in Art. 729 may be written to represent a straight line through these two points. The two points would, then, be indicated by  $(a, 0)$  and  $(0, b)$  with  $a$  the intercept on the  $X$ -axis and  $b$  the intercept on the  $Y$ -axis.

Calling the  $X$ -intercept  $P_2 = (a, 0)$ ,

$$x_2 = a \text{ and } y_2 = 0,$$

and calling the  $Y$ -intercept  $P_1 = (0, b)$ ,

$$x_1 = 0 \text{ and } y_1 = b.$$

Substituting in the two-point form of the equation of a straight line (Art. 729) gives

$$\frac{y - b}{x - 0} = \frac{0 - b}{a - 0} = -\frac{b}{a}.$$

$$a(y - b) = -bx, \text{ or } bx + ay = ab$$

Dividing through by  $ab$ , then

[342] 
$$\frac{x}{a} + \frac{y}{b} = 1.$$

This is the equation of the straight line in terms of its intercepts with the coordinate axes.

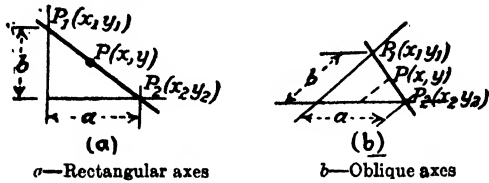

FIG. 390.

**EXAMPLE.**—A line cuts the  $X$ -axis at a distance of 8 from the origin and the  $Y$ -axis at a distance of  $-10$  from the origin. Find the equation of the line.

From the statement of the problem,

$$a = 8 \text{ and}$$

$$b = -10.$$

Substituting in  $\frac{x}{a} + \frac{y}{b} = 1$  gives

$$\frac{x}{8} - \frac{y}{10} = 1, \text{ or } 10x - 8y = 80.$$

$\therefore 5x - 4y = 40$  is the equation sought.

**731. The Normal Form.**—A line is completely determined if the length and direction of the perpendicular to it from the origin is known.

Let the distance from the origin to the straight line be  $p$  and let the angle which this perpendicular makes with the  $X$ -axis be  $\theta$ .

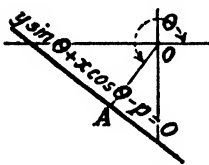

FIG. 391.

We desire to express the equation of the line in terms of  $p$  and  $\theta$  instead of in terms of  $x$  and  $y$ .

Let  $A$  be the foot of the perpendicular from the origin to the line. The coordinates of  $A$  in terms of  $p$  and  $\theta$  are

$$x = p \cos \theta \text{ and } y = p \sin \theta.$$

The slope of  $OA$  is  $\tan \theta$  and since the line is perpendicular to  $OA$ , the slope of the line is  $-\cot \theta$ , or  $m = -\cot \theta$ .

Making these substitutions in the point-slope formula,

$$y - y_0 = m(x - x_0),$$

we have

$$y - p \sin \theta = -\cot \theta(x - p \cos \theta).$$

Substituting,  $\cot \theta = \frac{\cos \theta}{\sin \theta}$ , and multiplying through by  $\sin \theta$  gives

$$y \cdot \sin \theta - p \sin^2 \theta = -x \cdot \cos \theta + p \cos^2 \theta.$$

Transposing to the left side and collecting,

$$y \cdot \sin \theta + x \cdot \cos \theta - p(\sin^2 \theta + \cos^2 \theta) = 0.$$

But  $\sin^2 \theta + \cos^2 \theta = 1$ .

Therefore,

[343] 
$$y \cdot \sin \theta + x \cdot \cos \theta - p = 0.$$

This is the equation of the straight line in terms of  $p$  and  $\theta$  and is called the normal form.

EXAMPLE.—Find the normal form of the equation of the straight line for which  $p = 10$  and  $\theta = 35^\circ$ .

Substituting,

$$x \cdot \cos 35^\circ + y \cdot \sin 35^\circ - 10 = 0.$$

**732. Intercept Form of the General Equation.**—If none of the quantities  $A$ ,  $B$ , and  $C$  are zero, the general equation,  $Ax + By + C = 0$ , can be put into the intercept form by transposing the constant term  $C$  to the right side of the equation, thus,

$$Ax + By = -C,$$

and dividing by  $-C$ ,

[344] 
$$\frac{A}{-C}x + \frac{B}{-C}y = 1,$$

or

$$\frac{x}{-\frac{C}{A}} + \frac{y}{-\frac{C}{B}} = 1.$$

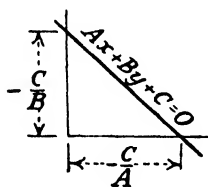

FIG. 392.

Comparing this with equation  $\frac{x}{a} + \frac{y}{b} = 1$  (Art. 730) gives

$a = -\frac{C}{A}$ , the  $X$ -intercept, and

$b = -\frac{C}{B}$ , the  $Y$ -intercept of the general equation.

If  $C = 0$ , both intercepts are zero.

If either  $A$  or  $B$  is zero, the line is parallel to an axis of coordinates.

**733. Normal Form of the General Equation.**—The  $x$  and  $y$  coordinates of the foot of the normal to the line are  $x = p \cos \theta$  and  $y = p \sin \theta$  (Art. 731).

Substituting in the general equation,

$$A \cdot p \cdot \cos \theta + B \cdot p \cdot \sin \theta + C = 0.$$

But the slope of the perpendicular (Art. 715) is the negative reciprocal of the slope of the line.

From Art. 731, the slope of the line in the general equation is

$$m = -\frac{A}{B}.$$

Therefore, the slope of the perpendicular is  $\frac{B}{A}$ , or

$$\tan \theta = \frac{B}{A}.$$

From trigonometry,

$$\cos \theta = \frac{1}{\pm \sqrt{1 + \tan^2 \theta}} \quad [273].$$

Substituting,

$$\cos \theta = \frac{1}{\pm \sqrt{1 + \left(\frac{B}{A}\right)^2}} = \frac{A}{\pm \sqrt{A^2 + B^2}}.$$

From trigonometry,

$$\tan \theta = \frac{\sin \theta}{\cos \theta} \quad [274].$$

Substituting the value of  $\cos \theta$ ,

$$\frac{\sin \theta}{\frac{A}{\pm \sqrt{A^2 + B^2}}} = \frac{B}{A}$$

$$\therefore \sin \theta = \frac{B}{\pm \sqrt{A^2 + B^2}}.$$

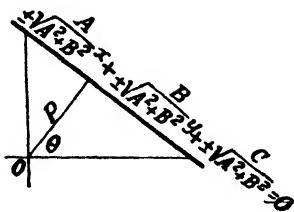

FIG. 393.

Substituting these values of  $\sin \theta$  and  $\cos \theta$  in

$$Ap \cos \theta + Bp \sin \theta + C = 0,$$

$$\frac{A^2 p}{\pm \sqrt{A^2 + B^2}} + \frac{B^2 p}{\pm \sqrt{A^2 + B^2}} = -C.$$

Dividing by  $\pm \sqrt{A^2 + B^2}$ ,

$$\frac{A^2 p}{A^2 + B^2} + \frac{B^2 p}{A^2 + B^2} = \frac{-C}{\pm \sqrt{A^2 + B^2}}.$$

$$\frac{p(A^2 + B^2)}{A^2 + B^2} = -\frac{C}{\pm \sqrt{A^2 + B^2}}.$$

$$-p = \frac{C}{\pm \sqrt{A^2 + B^2}}.$$



Substituting these values for  $\cos \theta$ ,  $\sin \theta$ , and  $p$  in the normal form of the equation of a straight line,

$$[345] \quad \frac{A}{\pm \sqrt{A^2 + B^2}}x + \frac{B}{\pm \sqrt{A^2 + B^2}}y + \frac{C}{\pm \sqrt{A^2 + B^2}} = 0.$$

This shows that the general form is reduced to the normal form by dividing the general form through by the square root of the sum of the squares of the coefficients of  $x$  and  $y$ . The sign of the radical should be taken opposite to the sign of  $C$  so that  $p$  will be positive.

**734. Equation of a Line through the Point  $(x_0, y_0)$  and Perpendicular to the Line  $Ax + By + C = 0$ .**—Assume the equation of the line to be of the form,

$$y - y_0 = m'(x - x_0).$$

The slope of the line,  $Ax + By + C = 0$ , is  $-\frac{A}{B}$ .

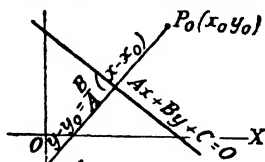

FIG. 394.

Since the required line is perpendicular to this line, its slope is the negative reciprocal of the slope of the given line, or

$$m' = \frac{B}{A}.$$

The equation of the required line is then

$$[346] \quad y - y_0 = \frac{B}{A}(x - x_0),$$

where  $x_0$  and  $y_0$  are the coordinates of the given point.

**735. Distance from a Given Point  $P(x_0, y_0)$  to the Line  $Ax + By + C = 0$ .**—Translate the origin to the given point  $P(x_0, y_0)$ , and write the new equation of the line. To translate, see Arts. 172, 205, 236, and 279.

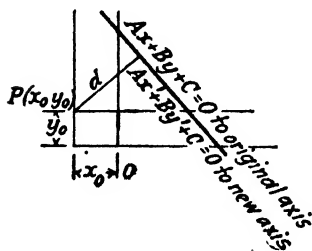

FIG. 395.

This is equal to

$$Ax' + By' + Ax_0 + By_0 + C = 0,$$

where  $x'$  and  $y'$  are the variable coordinates, while

$$Ax_0 + By_0 + C$$

is the constant term.

$$x = x_0 + x'. \quad y = y_0 + y'.$$

Substituting in the equation of the line,

$$A(x' + x_0) + B(y' + y_0) + C = 0.$$

From Art. 733, the perpendicular distance from the origin to the line is the constant term divided by  $\pm\sqrt{A^2 + B^2}$ . Therefore,

$$[347] \quad d = \frac{Ax_0 + By_0 + C}{\pm\sqrt{A^2 + B^2}},$$

where  $x_0$  and  $y_0$  are the coordinates of the given point.

EXAMPLE.—Harbor  $B$  is 500 miles directly north from  $A$  and harbor  $C$  is 800 miles due east of  $A$ . A vessel sails from  $B$  to  $C$ . A warship is stationed 600 miles east and 400 miles north of  $A$ . How near will the vessel come to the warship?

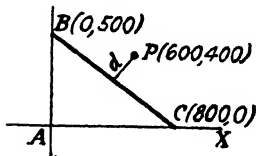

FIG. 396.

Draw the graph as shown in Fig. 396.

It will be readily seen from the figure that the intercepts are given so that the equation of the line  $BC$  may be written by substitution in the intercept form of the equation.

$$\frac{x}{a} + \frac{y}{b} = 1.$$

Here  $a = 800$ .

$b = 500$ .

Substituting,

$$\frac{x}{800} + \frac{y}{500} = 1 \text{ or } 5x + 8y - 4000 = 0.$$

Comparing with  $Ax + By + C = 0$ ,

$$A = 5, B = 8, \text{ and } C = -4000.$$

The coordinates of  $P$  are  $(600, 400)$ . Hence,

$$x_0 = 600, y_0 = 400.$$

Substituting these values in

$$d = \frac{Ax_0 + By_0 + C}{\pm\sqrt{A^2 + B^2}} [347],$$

$$d = \frac{5 \cdot 600 + 8 \cdot 400 - 4000}{\pm\sqrt{25 + 64}} = \frac{2200}{\sqrt{89}}$$

$\log d = \log 2200 - \frac{1}{2} \log 89$ ; whence,

$$d = 233.2.$$

**736. The Equation of a Line through the Point  $P(x_0, y_0)$ , Making an Angle  $\theta$  with  $Ax + By + C = 0$ .**—Suppose that the slope of the required line is  $m'$  and that the slope of the given line is  $m$ .

Since by Art. 726 we may write the equation of a line through  $P$  having a slope  $m'$  by substituting in

$$y - y_0 = m'(x - x_0),$$

there remains only to determine  $m'$ .

From Art. 716,

$$\tan \theta = \frac{m - m'}{1 + mm'}, \text{ or } \frac{m' - m}{1 + mm'},$$

where  $\theta$  is the angle between two lines having slopes  $m$  and  $m'$ . Bear in mind that two angles are possible and solve for  $m'$ .

Then

$$m' = \frac{m \pm \tan \theta}{1 \mp m \tan \theta} \text{ [280].}$$

From Art. 727,

$$m = -\frac{A}{B}.$$

Then

$$m' = \frac{-\frac{A}{B} \pm \tan \theta}{1 \pm \frac{A}{B} \cdot \tan \theta}.$$

Substituting in point-slope formula above,

$$\text{[348] } y - y_0 = \frac{-\frac{A}{B} \pm \tan \theta}{1 + \frac{A}{B} \cdot \tan \theta} (x - x_0).$$

**737. Polar Equations of Straight Lines through Two Points, as  $P_1(\rho_1, \theta_1)$  and  $P_2(\rho_2, \theta_2)$  is**

$$\text{[349] } \rho \rho_1 \sin(\theta - \theta_1) + \rho_1 \rho_2 \sin(\theta_1 - \theta_2) + \rho \rho_2 \sin(\theta_2 - \theta) = 0,$$

where  $(\rho, \theta)$  are the variable coordinates of any point on the line.

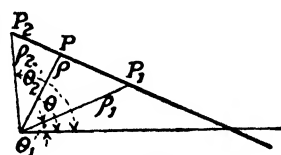

FIG. 397.

**738. Systems of Straight Lines.**—Consider the equation,

$$\text{[350] } y - mx = k.$$

If the left member of the equation remains unchanged but the constant term  $k$  be given different arbitrary values, the graphs of the equations form a set of parallel lines since they all have the same slope.

The number  $k$  which is constant for any one line of the system but which varies when we change from one line to another is called a *parameter* and the parallel lines form a system.

If our problem is to locate a particular line of the system, for instance, the line passing through  $(2, 2)$  and parallel to  $y - 3x =$

2, then by retaining the equation in the form  $y - 3x = k$ , we keep the parallel condition and by finding the proper value of  $k$ , locate the line.

If a line passes through a point, the coordinates of the point must satisfy the equation of the locus.

Substitute (2, 2) in

$$y - 3x = k.$$

Then

$$2 - 6 = k, \text{ or} \\ k = -4.$$

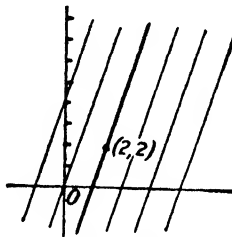

FIG. 398.

The  $Y$ -intercept of the desired line is  $-4$  and since there can be but one line of the system which has a  $Y$ -intercept at  $-4$ , we can substitute this value for  $k$  in the equation of the system, thus,

$$y - 3x = -4, \text{ or } y - 3x + 4 = 0,$$

to obtain the equation of the particular line.

**739. System of Lines Perpendicular to  $y - mx = k$ .**—Comparing the equations,

$$y - mx = k \text{ and} \\ my + x = k,$$

it will be seen that the slope  $m$  in the first equation is the negative reciprocal of the slope  $m$  in the second. From Art. 715, this indicates that the line represented by the second equation is perpendicular to the line represented by the first equation.

If  $k$  is given different values as before in the two equations, we have two systems of lines, one system perpendicular to the other. If our problem is to write the equation of one line perpendicular to another and passing through a certain point, we can form the line equation in the perpendicular form by interchanging the coefficients of  $x$  and  $y$  and changing the sign of the  $y$  term. This

amounts to the same thing as inverting and changing the sign of the slope.

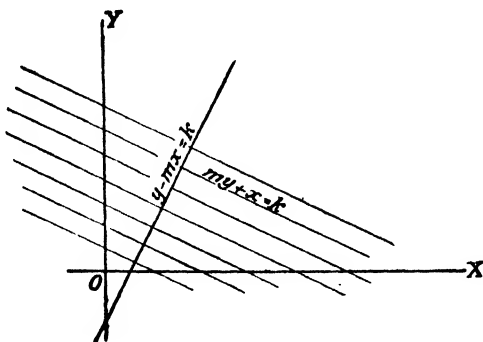

FIG. 399.

Assuming a line, as

$$2x + 3y - 4 = 0,$$

then the perpendicular form is

$$3x - 2y = k.$$

If our problem is to write the equation of a line perpendicular to  $2x + 3y - 4 = 0$  and passing through the point  $(3, -2)$ , we first determine  $k$  by substituting coordinates in  $3x - 2y = k$ .

Note that the substitution is not made in  $2x + 3y - 4 = 0$  because the point  $(3, -2)$  is not in that line.

$$\begin{aligned} 3 \cdot 3 - 2(-2) &= k. \\ 9 + 4 &= k. \\ k &= 13. \end{aligned}$$

Substituting in the perpendicular form,

$$3x - 2y = 13.$$

This is the equation of the required line perpendicular to  $2x + 3y - 4 = 0$  and passing through the point  $(3, -2)$ .

**740. System of Lines through a Point.**—Consider the form,

$$y - y_0 = m(x - x_0).$$

Take  $(x_0, y_0)$  as  $(3, -3)$ ; then the equation is

$$y + 3 = m(x - 3).$$

By giving  $m$  various values, another system of lines develop, all of which pass through the point  $(3, -3)$ .

If the problem is to find the equation of a line of slope equal to 2 through the point  $(2, 2)$ , we can immediately write

$$\begin{aligned} y - 2 &= 2(x - 2), \text{ or} \\ y - 2x + 2 &= 0. \end{aligned}$$

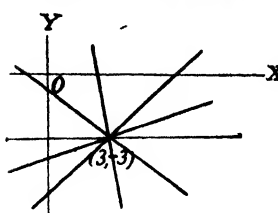

FIG. 400.

The equation is

$$y - 2 = -\frac{1}{5}(x - 2), \text{ or } 5y - 10 = -x + 2.$$

$$x + 5y - 12 = 0.$$

Comparing with the two-point form (Art. 729),

$$\frac{y - y_1}{x - x_1} = \frac{y_2 - y_1}{x_2 - x_1}$$

$$\frac{y - 2}{x - 2} = \frac{2 - 3}{2 - 3} = -\frac{1}{1}.$$

$$-5y + 10 = x - 2.$$

$$x + 5y - 12 = 0.$$

**741. System of Lines through Intersection of Two Given Lines.**—If

$$Ax + By + C = 0 \text{ and}$$

$$A'x + B'y + C' = 0$$

represent two straight lines, then

[351]  $Ax + By + C + k(A'x + B'y + C') = 0$

represents a system of straight lines passing through the intersection of  $Ax + By + C = 0$  and  $A'x + B'y + C' = 0$ .

For convenience, let

$$f(x, y) = Ax + By + C = 0 \text{ and}$$

$$g(x, y) = A'x + B'y + C' = 0.$$

Then, from the above,

$$f(x, y) + k[g(x, y)] = 0$$

defines the system, with  $k$  as a parameter.

Let the point of intersection of the two given lines be  $P(a, b)$ .

Then  $f(x, y) = 0$  and  $g(x, y) = 0$  are both satisfied when  $x = a$  and  $y = b$  since  $P(a, b)$  lies on both lines.

If  $f(a, b) = 0$  and  $g(a, b) = 0$ , then

$$f(a, b) + k[g(a, b)] = 0$$

for all values of  $k$ .

Hence, every line of the system,  $f(x, y) + k[g(x, y)]$ , passes through  $P(a, b)$  since its coordinates satisfy the equation.

The advantage of this method is evident from the following:

**EXAMPLE.**—Find the equation of the line through the intersection of the lines,

$$2x + y - 4 = 0 \text{ and } x + 3y - 3 = 0,$$

and the point  $P(3, 3)$ .

Writing the equation of the system through the intersection of the two given lines,

$$2x + y - 4 + k(x + 3y - 3) = 0.$$

Since the desired line contains the point  $P(3, 3)$ , its coordinates must satisfy the equation of the line. Substituting  $x = 3$  and  $y = 3$  in the equation of the system,

$$6 + 3 - 4 + k(3 + 9 - 3) = 0.$$

Whence

$$5 + 9k = 0.$$

$$k = -\frac{5}{9}.$$

Then

$$2x + y - 4 - \frac{5}{9}(x + 3y - 3) = 0.$$

Reducing,

$$13x - 6y - 21 = 0$$

is the equation of the line sought.

**EXAMPLE.**—Find the equation of the line passing through the intersection of the lines,

$$2x + y + 2 = 0 \text{ and } x - 2y + 2 = 0,$$

and parallel to the line,

$$3x - 4y - 5 = 0.$$

The equation of the system of lines passing through the intersection of the given lines is

$$\begin{aligned} 2x + y + 2 + k(x - 2y + 2) &= 0, \text{ or} \\ (2 + k)x + (1 - 2k)y + 2(1 + k) &= 0. \end{aligned}$$

The slope of this line is

$$-\frac{2 + k}{1 - 2k}.$$

This slope must be equal to the slope of  $3x - 4y - 5 = 0$ , or  $\frac{3}{4}$ ; therefore,

$$-\frac{2 + k}{1 - 2k} = \frac{3}{4}, \text{ or } k = \frac{11}{2}.$$

Substituting,

$$2x + y + 2 + \frac{11}{2}(x - 2y + 2) = 0.$$

Reducing,

$$15x - 20y + 26 = 0, \text{ or}$$

$$3x - 4y + \frac{13}{5} = 0.$$

The parallelism is indicated in the second form, for the coefficients of  $x$  and  $y$  are the same as in the equation of the line to be paralleled.

This last method applies to any equation of the form,

$$f(x, y) = 0,$$

as well as to the straight-line equation, and use will be made of this principle in later sections.

The principal advantage of this method lies in the fact that we do not need to know the coordinates of the point of intersection of the two lines, although these may be readily found in the above example by solving the two equations simultaneously. When the coordinates are not easily found from the given equations, however, the above method may be used to advantage.

**742. Form  $x \cos k + y \sin k - p = 0$  [352].**—In this, we readily recognize the normal form and by giving  $k$  various values, a system of lines, each  $p$  units from the origin, is represented.

If the line determined by the equation,

$$x \cos k + y \sin k - 2 = 0,$$

passes through the point  $(4, 0)$ , then

$$4 \cos k = 2, \cos k = \frac{1}{2}.$$

$$\sin k = \pm \sqrt{1 - \cos^2 k} = \pm \sqrt{\frac{3}{4}} = \pm \frac{\sqrt{3}}{2}.$$

Then

$$x \cos k + y \sin k - 2 = 0 \text{ becomes}$$

$$\frac{x}{2} \pm \frac{\sqrt{3}}{2}y - 2 = 0, \text{ or } x \pm \sqrt{3}y - 4 = 0.$$

Any of the standard forms of the straight-line equation involves two arbitrary constants. If one is given a numerical value and the other left arbitrary, we get a system of straight lines.

From the preceding discussion, the convenience of using the general formula for a system of lines is apparent when it is desired to find a line which fulfils two conditions, for the general equation may be written so as to fulfil one condition and the parameter determined which fulfils the other condition, thus determining the line.

**743. Product of Two Line Equations.**—If each of the equations,

$$Ax + By + C = 0 \text{ and}$$

$$A'x + B'y + C' = 0,$$



represents a straight line, then the single equation,  
 $(Ax + By + C)(A'x + B'y + C') = 0$ ,  
 represents the two lines.

If the coordinates of a point  $P(a, b)$  on line  
 $Ax + By + C = 0$  (or  $A'x + B'y + C' = 0$ )  
 satisfy the equation, then the left side of the equation is zero  
 for  $x = a$  and  $y = b$ . The values of  $P(a, b)$  which satisfy either  
 of the equations of the given lines then satisfy the equation of the  
 product, which means that every point on either the locus  
 represented by  $Ax + By + C = 0$  or the locus represented by  
 $A'x + B'y + C' = 0$  lies also on the locus represented by  
 $(Ax + By + C)(A'x + B'y + C') = 0$ .

EXAMPLE.  $x + 2y = 0$ .  
 $x - 2y - 1 = 0$ .

The product is  $x^2 - 4y^2 - x - 2y = 0$ .

The coordinates of any point, as  $(2, -1)$  on line  $x + 2y = 0$ , make its  
 equation zero, thus,  $2 - 2 = 0$ , and hence, the product of this factor  
 by another is zero.

Therefore, all points on  $x + 2y = 0$  lie on the locus,  $x^2 - 4y^2 - x - 2y = 0$ .

The same is true of  $x - 2y - 1 = 0$ .

#### 744. Second-degree Equations Representing Straight Lines.—

An equation whose right-hand member is zero and whose left  
 member can be broken up into factors of the first degree represents  
 straight lines.

EXAMPLE.— $3x^2 + 10xy + 8y^2 = 0$  represents two lines, for it may be  
 factored thus,

$$(3x + 4y)(x + 2y) = 0.$$

The lines are

$$3x + 4y = 0 \text{ and} \\ x + 2y = 0.$$

The coordinates of all points on these lines satisfy the given equation.  
 Art. 743.

The lines need not necessarily intersect and may be parallel, as

$$x^2 + y^2 + 2xy + 3x + 3y + 2 = 0$$

when factored becomes two parallel lines,

$$x + y + 1 = 0 \text{ and} \\ x + y + 2 = 0.$$

## CHAPTER XXXII

### SECOND-DEGREE EQUATIONS. CONICS. THE PARABOLA

#### CONICS

**745.** The locus of a point which moves so that its distance from a fixed point is in a constant ratio to its distance from a fixed line is called a *conic*.

The fixed point is called the *focus* and the fixed line the *directrix*.

The constant ratio is called the *eccentricity* and is represented by  $e$ .

Conics are divided into three classes:

If  $e = 1$ , the curve is a *parabola*.

If  $e < 1$ , the curve is an *ellipse*.

If  $e > 1$ , the curve is an *hyperbola*.

The fact that these curves are cut from cones by intersecting planes is the reason given for calling them conics.

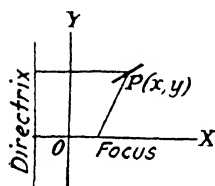

FIG. 401.

#### **746. Equation of Any Conic in Rectangular Coordinates.—**

Let the fixed line, or directrix, be the  $Y$ -axis and the fixed point on the  $X$ -axis at  $(p, 0)$ , and let  $P(x, y)$  be any point on the curve. Then from definition of conic,

$$\frac{FP}{PN} = e.$$

Using distance formula [329],

$$FP = \sqrt{(x - p)^2 + (y - 0)^2} = \sqrt{(x - p)^2 + y^2}.$$

$$PN = x.$$

Then

$$e = \frac{\sqrt{(x - p)^2 + y^2}}{x}.$$

Squaring,

$$e^2 = \frac{(x - p)^2 + y^2}{x^2}.$$

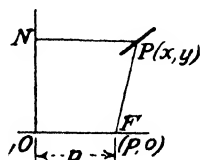

FIG. 402.

[353]  $(1 - e^2)x^2 + y^2 - 2px + p^2 = 0,$

which is the equation of the conic.

To find the intercepts on the  $X$ -axis, let  $y = 0$ .

Then

$$(1 - e^2)x^2 + 0 - 2px + p^2 = 0,$$

and

$$x = \frac{p}{1 \pm e}.$$

**747. Equation of Conic in Polar Coordinates.**—In the figure, take the pole at the focus and  $OX$  as the polar axis.

Let  $P (\rho, \theta)$  be any point on the curve.

From definition of conic,

$$OP = ePN. \tag{1}$$

$$OP = \rho.$$

$$PN = p + OM = p + \rho \cos \theta.$$

Substituting values of  $OP$  and  $PN$  in (1),

$$\rho = e(p + \rho \cos \theta) = ep + e\rho \cos \theta.$$

$$\rho - e\rho \cos \theta = ep.$$

[354]  $\therefore \rho = \frac{ep}{1 - e \cos \theta}.$

It will be seen later that some of the conics have two foci and two directrices.

The equation referred to the other focus and directrix is

$$\rho = \frac{ep}{1 + e \cos \theta}.$$

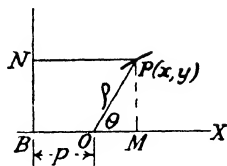

FIG. 403.

PARABOLA

**748. Equation of Parabola.**—In the case of the parabola  $e = 1$ , and hence, the curve is the locus of a point equidistant from the focus and the directrix.

From the definition, there is a point midway between the focus and the directrix where the locus cuts the  $X$ -axis. This point is called the vertex.

It is convenient to take the origin at the vertex because it results in a much simpler equation.

Then the coordinates of the focus are

$$\left(\frac{p}{2}, 0\right),$$

and the equation of the directrix is

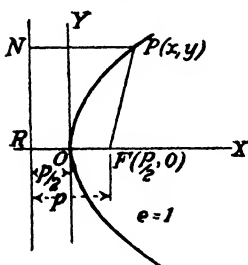

FIG. 404.

$x = -\frac{p}{2}$ , where  $p$  is the distance  $RF$ .

Let  $P(x, y)$  be any point on the locus.

By definition,  $FP = PN$ .

By distance formula [329],

$$FP = \sqrt{\left(x - \frac{p}{2}\right)^2 + y^2}.$$

$$PN = x + \frac{p}{2}.$$

Then

$$\sqrt{\left(x - \frac{p}{2}\right)^2 + y^2} = x + \frac{p}{2}.$$

Squaring and simplifying,

$$[355] \quad y^2 = 2px.$$

The equation of the directrix is  $x = -\frac{p}{2}$ .

The focus is at the point  $\left(\frac{p}{2}, 0\right)$ .

This equation shows that the parabola is symmetrical with respect to the  $X$ -axis and that the locus crosses the  $X$ -axis at the vertex only.

A different-sized parabola is obtained for different values of  $p$ .

The equation of a parabola whose axis is the  $Y$ -axis and whose vertex is at the origin is obtained by interchanging  $x$  and  $y$ , or

$$[356] \quad x^2 = 2py.$$

The equation of the directrix is

$$y = -\frac{p}{2},$$

and the focus is at the point

$$\left(0, \frac{p}{2}\right).$$

If  $p$  is negative, the locus is inverted as is shown in  $b$  (Fig. 405).

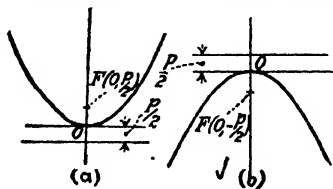

FIG. 405.

**749. Conic Equation Reduced. Equation of Parabola.**—The equation of conic is [353],

$$(1 - e^2)x^2 + y^2 - 2px + p^2 = 0.$$

But  $e = 1$  in the parabola, so that

$$y^2 = 2px - p^2,$$

which can be written,

$$y^2 = 2p\left(x - \frac{p}{2}\right).$$

Let the origin now be translated to  $\left(\frac{p}{2}, 0\right)$ ; then

$$x = x' + \frac{p}{2}, y = y'.$$

Substituting in  $y^2 = 2px - p^2$ ,

$$y'^2 = 2p\left(x' + \frac{p}{2}\right) - p^2.$$

$$y'^2 = 2px'.$$

Dropping primes,

$$y^2 = 2px \text{ [355]},$$

which is the equation of the parabola.

**750. Latus Rectum.**—The chord  $LL_1$  through the focus and parallel to the directrix is called the *latus rectum*. From the definition of the parabola, the distance of  $L$  from the focus and the directrix is the same and in this case is equal to  $p$ . The total length of the latus rectum is, then,  $2p$ .

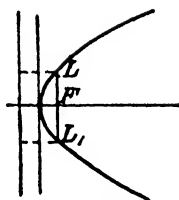

FIG. 406.

**751. The Parabola and Quadratic Equations.**—Considerable attention was given to the conic sections and particularly to the parabola in the algebra section (Art. 169 *et seq.*). Its relation to quadratic and power functions has been explained, and a review of those articles is advisable at this point.

The article on the translation of the axes or origin is of particular importance since it applies to all conics.

Comparing the power function,  $y = ax^2$ , in Art. 170 with the equation,  $x^2 = 2py$ , we see that the equations are of the same form with the constant  $a$  equal to  $\frac{1}{2p}$ .

**Axis of Parabola Translated.**—Transform equation  $y^2 = 2px$  by translating the origin to the point  $O'$  ( $-h, -k$ ) (see Art. 171).

Then

$$x = x_1 - h, \text{ and}$$

$$y = y_1 - k.$$

Substitute in

$$y^2 = 2px.$$

$$(y_1 - k)^2 = 2p(x_1 - h).$$

Since  $(x_1, y_1)$  can be any point on the locus, we can drop the primes, and the equation becomes

$$[357] \quad (y - k)^2 = 2p(x - h).$$

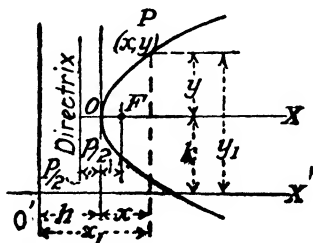

FIG. 407.

NOTE.—The origin may also be taken at  $(h, k)$  and [357] would then be  $(y + k)^2 = 2p(x + h)$ .

The focus is located at  $(h + \frac{p}{2}, k)$ .

The equation of the directrix is  $y = h - \frac{p}{2}$ .

**752. General Equation of a Parabola Parallel to the X- or Y-axis.**—Equations of the forms,

$$y^2 + Dx + Ey + F = 0 \text{ where } D \neq 0 \text{ and} \quad (1)$$

$$x^2 + Dx + Ey + F = 0 \text{ where } E \neq 0 \quad (2)$$

then both represent parabolas. (1) has its axis parallel to the X-axis and (2) has its axis parallel to the Y-axis.

To prove this, complete the square in (1) which gives

$$y^2 + Ey + \frac{E^2}{4} = -Dx + \frac{E^2}{4} - F, \text{ or}$$

$$[358] \quad \left(y + \frac{E}{2}\right)^2 = -D\left(x - \frac{E^2 - 4F}{4D}\right),$$

which is in the form of [357], where

$$h = \frac{E^2 - 4F}{4D}, \quad k = -\frac{E}{2}, \quad 2p = -D, \text{ or } p = -\frac{D}{2}.$$

If we examine (2) in the same manner, then

$$[359] \quad \left(x + \frac{D}{2}\right)^2 = -E\left(y - \frac{D^2 - 4F}{4E}\right),$$

and

$$k = \frac{D^2 - 4F}{4E}, \quad h = -\frac{D}{2}, \quad 2p = -E,$$

and the distance from the focus to the directrix, or  $p = -\frac{E}{2}$ .

**753. Quadratic Form  $y = ax^2 + bx + c$  [3].**—This form reduces to form [357], for, by completing the square in  $x$ , then

$$y = a\left(x + \frac{b}{2a}\right)^2 - \frac{b^2 - 4ac}{4a}, \text{ or}$$

$$[360] \quad \left(x + \frac{b}{2a}\right)^2 = \frac{1}{a}\left(y + \frac{b^2 - 4ac}{4a}\right).$$

In this case it will be seen that

$$h = -\frac{b}{2a} \text{ and } k = -\frac{b^2 - 4ac}{4a}.$$

This is the equation of a parabola since it reduces to form [357]. The vertex is at the point  $(h, k)$ , or

$$\left(-\frac{b}{2a}, -\frac{b^2 - 4ac}{4a}\right).$$

This form has been discussed in the algebra section (Art. 171 *et seq.*) together with the translations involved, and a review of these articles will, doubtless, add to clearness and make repetition unnecessary. It was introduced in the algebra section to make the graphical relations clear.

**754. Equation of Parabola in Polar Coordinates.**—For the parabola,  $e = 1$ , which substituted in

$$\rho = \frac{ep}{1 - e \cos \theta} \quad [354]$$

gives

$$[361] \quad \rho = \frac{p}{1 - \cos \theta}.$$

**755. Construction of Parabola.**—Referring to the method used in Art. 180, a proof of the method will now be given.

In Fig. 409,

$$x = M'P, \quad y = OM',$$

$$AB = 2a, \quad OH = h.$$

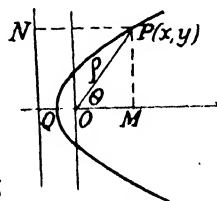

FIG. 408.

By construction,  $NC$  and  $MH$  are equal parts of  $AC$  and  $AH$ , respectively.

Therefore,

$$\frac{NC}{AC} = \frac{MH}{AH}, \text{ or } \frac{NC}{h} = \frac{y}{a}. \tag{1}$$

And from similar triangles,

$$\frac{x}{y} = \frac{NC}{OC} = \frac{NC}{a}. \tag{2}$$

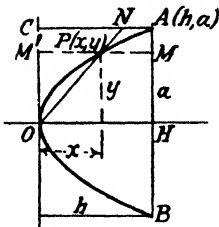

FIG. 409.

But from (1)  $NC = \frac{hy}{a}$ , which when substituted for  $NC$  in (2) gives

$$\frac{x}{y} = \frac{\frac{hy}{a}}{a}, \text{ or } y^2 = \frac{a^2}{h}x.$$

This is the typical form of the parabola [355].

**756. Path of a Projectile.**—Consider a projectile starting at the origin with an initial velocity  $V$  feet per second, and making an angle  $\alpha$  with the horizontal.

If not influenced by any other forces, such as wind or gravity, the projectile would continue in the same direction and at the same velocity.

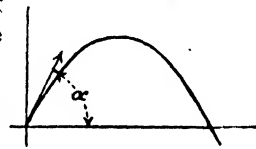

FIG. 410.

The  $x$  and  $y$  coordinates at the end of  $t$  seconds would be

$$x = t \cdot V \cos \alpha \text{ and } y = t \cdot V \sin \alpha.$$

If the force of gravity is taken into account, then  $y$  is decreased by  $\frac{1}{2}gt^2$  in  $t$  seconds.

The coordinates of the projectile at the end of  $t$  seconds are then

$$x = t \cdot V \cos \alpha \tag{1}$$

$$y = t \cdot V \sin \alpha - \frac{1}{2}gt^2. \tag{2}$$

Eliminating  $t$  between these two equations by substituting the value of  $t$  found from (1) in equation (2),

$$t = \frac{x}{V \cos \alpha}.$$

$$y = \frac{x}{V \cos \alpha} \cdot V \sin \alpha - \frac{g}{2} \cdot \frac{x^2}{V^2 \cos^2 \alpha}.$$



Reducing,

$$y = (\tan \alpha)x - \frac{g}{2V^2 \cos^2 \alpha} \cdot x^2.$$

This is a parabola of the form of Art. 752 (2).

**757. Parabolic Arch.**—The equation of the parabola of the form shown in Fig. 411 with the origin at the vertex is  $x^2 = -2py$ .

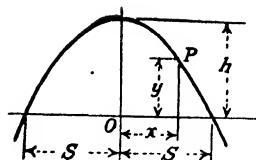

FIG. 411.

Since it is more convenient to measure the height of the arch as shown, we will translate the origin to  $O$ .

Then  $y = y' - h$ .

Substituting and dropping primes,

$$x^2 = -2p(y - h),$$

when  $x = s, y = 0$ .

Then

$$s^2 = -2p(0 - h).$$

$$s^2 = 2ph.$$

$$p = \frac{s^2}{2h}.$$

By assuming any values for  $h$  and  $s$  and substituting in above equation, the ordinates  $y$  can be determined for different values of  $x$ . Hence, the equation of the arch is

$$x^2 = -\frac{s^2}{h}(y - h),$$

which reduces to

$$y = h - \frac{hx^2}{s^2}$$

For a graphical method see Art. 180.

## CHAPTER XXXIII

### THE CIRCLE AND THE ELLIPSE

#### THE CIRCLE

**758.** In geometry, the circle is defined as the locus of all points equidistant from a fixed point called the center of the circle.

Let  $(h, k)$  be the fixed point and  $r$  the constant distance or radius.

From the distance formula [329],

$$CP = r = \sqrt{(x - h)^2 + (y - k)^2}.$$

Squaring both sides,

[362]  $(x - h)^2 + (y - k)^2 = r^2.$

This is the equation of the circle.

If  $h = 0$  and  $k = 0$ , or the origin is at the center, then

$$(x - 0)^2 + (y - 0)^2 = r^2, \text{ or}$$

$$x^2 + y^2 = r^2 \text{ [19]}$$

This is the equation of a circle whose center is at the origin.

If we expand  $(x - h)^2 + (y - k)^2 = r^2$ , then

$$x^2 + y^2 - 2hx - 2ky + h^2 + k^2 - r^2 = 0.$$

Comparing this equation with the general equation of second degree,

$$Ax^2 + Bxy + Cy^2 + Dx + Ey + F = 0,$$

we note that the  $xy$  term is missing in the equation of the circle and also that the coefficients of  $x^2$  and  $y^2$  are equal.

The *general equation* of the circle is, therefore,

[363]  $x^2 + y^2 + Dx + Ey + F = 0.$

The coordinates of the center and the radius are given by

$$h = -\frac{D}{2}, \quad k = -\frac{E}{2}, \quad r = \frac{1}{2} \sqrt{D^2 + E^2 - 4F}.$$

If  $D^2 + E^2 - 4F > 0$ , the equation represents a circle.

If  $D^2 + E^2 - 4F = 0$ , the radius equals zero and the locus is a point.

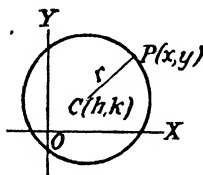

FIG. 412.

If  $D^2 + E^2 - 4F < 0$ , the radius is imaginary and the circle is imaginary.

If  $D = 0$ , then  $h = 0$ , and the center lies on the  $Y$ -axis.

If  $E = 0$ , then  $k = 0$ , and the center lies on the  $X$ -axis.

If  $D = 0$ , and  $E = 0$ , the center is at the origin.

If  $F = 0$ , then  $h^2 + k^2 = r^2$ , and the origin is on the circumference.

**759. Determination of Circles.**—Since the equations [362] and [363] have three arbitrary constants, as  $h$ ,  $k$ , and  $r$  in the first case and  $D$ ,  $E$ , and  $F$  in the second case, it is necessary to find different conditions (three in number) to determine these constants so that the equation of the circle may be written. These conditions may be geometrical, or by imposing different conditions on the equations of [362] and [363], a set of simultaneous equations can be made from which the values of the constants may be determined algebraically.

**EXAMPLE.**—Find the equation of a circle passing through the points  $(1, 7)$ ,  $(8, 6)$ , and  $(7, -1)$ .

Each pair of coordinates must satisfy the equation of the circle [362],

Hence,

$$\begin{aligned}(1 - h)^2 + (7 - k)^2 &= r^2. \\(8 - h)^2 + (6 - k)^2 &= r^2. \\(7 - h)^2 + (-1 - k)^2 &= r^2.\end{aligned}$$

Solving simultaneously,

$$h = 4, k = 3, r = 5.$$

Therefore, the desired equation is

$$(x - 4)^2 + (y - 3)^2 = 5^2,$$

which reduces to

$$x^2 + y^2 - 8x - 6y = 0.$$

Using the general form [363] for the equation of the circle and substituting the coordinates of the given points gives

$$\begin{aligned}1 + 49 + D + 7E + F &= 0. \\64 + 36 + 8D + 6E + F &= 0. \\49 + 1 + 7D - E + F &= 0.\end{aligned}$$

Solving,

$$D = -8, E = -6, F = 0.$$

Substituting in [363],

$$x^2 + y^2 - 8x - 6y = 0,$$

as before.

**EXAMPLE.**—Find the equation of the circle with center on the line,  $2x + 3y = 0$ , and passing through the points  $P_1(0, -4)$  and  $P_2(4, 0)$ .

Let the required equation be

$$x^2 + y^2 + Dx + Ey + F = 0.$$

Since  $P_1$  and  $P_2$  are on the locus, their coordinates must satisfy the equation of the locus; therefore, we substitute coordinates of  $P_1$  and  $P_2$ . Then

$$0 + 16 + 0 - 4E + F = 0 \text{ and}$$

$$16 + 0 + 4D - 0 + F = 0.$$

The center of the circle whose coordinates are  $\left(-\frac{D}{2}, -\frac{E}{2}\right)$  lies on the line,  $2x + 3y = 0$ , or substituting,

$$2\left(-\frac{D}{2}\right) + 3\left(-\frac{E}{2}\right) = 0, \text{ or } 2D + 3E = 0.$$

Solving,

$$16 - 4E + F = 0.$$

$$16 + 4D + F = 0.$$

$$2D + 3E = 0.$$

Then

$$E = 0, F = -16, D = 0.$$

Equation [363] becomes

$$x^2 + y^2 = 16.$$

The radius is 4 and the origin is the center.

**760. Polar Equation of Circle.**—Let  $OA$  be the initial line,  $O$  the pole,  $C$  the center at  $(\rho_1, \theta_1)$ .

The equation is

$$[364] \quad \rho^2 - 2\rho\rho_1 \cos(\theta - \theta_1) + \rho_1^2 - r^2 = 0.$$

If the center is on the polar axis,

$$[365] \quad \rho^2 - 2\rho\rho_1 \cos \theta + \rho_1^2 - r^2 = 0.$$

If the pole is on the circle,

$$[366] \quad \rho - 2r \cos(\theta - \theta_1) = 0.$$

If the pole is on the circle and the polar axis is a diameter,

$$[367] \quad \rho - 2r \cos \theta = 0.$$

If the center is at the pole,

$$\rho = r.$$

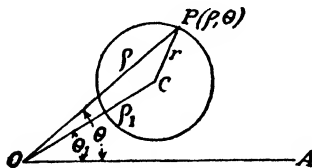

FIG. 413.

**761. Systems of Circles.**—If  $f(x, y) = 0$  and  $g(x, y) = 0$  are equations of two circles, then by Art. 741,

$$f(x, y) + k[g(x, y)] = 0$$

is the equation of a curve through all of the points of intersection of  $f(x, y)$  and  $g(x, y)$ .

The curve is either a circle or a straight line which is the common chord of the circles.

$$\text{Let } f(x, y) = A_1x^2 + A_1y^2 + D_1x + E_1y + F_1 = 0$$

$$\text{and } g(x, y) = A_2x^2 + A_2y^2 + D_2x + E_2y + F_2 = 0.$$

Then  $f(x, y) + k[g(x, y)] = 0$  becomes

$$[368] \quad A_1x^2 + A_1y^2 + D_1x + E_1y + F_1 + k[A_2x^2 + A_2y^2 + D_2x + E_2y + F_2] = 0,$$

which can be put into the form,

$$(A_1 + kA_2)x^2 + (A_1 + kA_2)y^2 + (D_1 + kD_2)x + (E_1 + kE_2)y + (F_1 + kF_2) = 0.$$

Since the coefficients of  $x^2$  and  $y^2$  are equal and there is no  $xy$  term, this is the equation of a circle.

The exceptional case is where the coefficient  $(A_1 + kA_2)$  of  $x^2$  and  $y^2$  becomes zero, in which case the equation represents a straight line which is the common chord.

Advantage may be taken of this last condition in finding the common chord, for, by giving  $k$  the value,

$$k = -\frac{A_1}{A_2},$$

the  $x^2$  and  $y^2$  terms are eliminated and the resulting equation which is satisfied by the common points of the two circles represents a straight line through their points of intersection or their common chord.

**EXAMPLE.**—Assume general equation of two circles, as

$$x^2 + y^2 + D_1x + E_1y + F_1 = 0 \text{ and}$$

$$x^2 + y^2 + D_2x + E_2y + F_2 = 0.$$

Putting  $k = -1$ , or what is the same thing, subtracting the second equation from the first, we get

$$(D_1 - D_2)x + (E_1 - E_2)y + F_1 - F_2 = 0,$$

which is the equation of the common chord of the two circles.

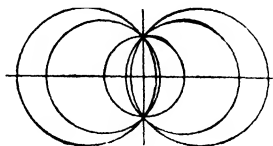

FIG. 414.

In the case where the two circles are tangent, the line represented by the resulting equation is the common tangent of the circles.

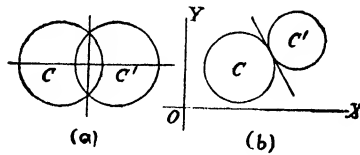

FIG. 415.

EXAMPLE.—Find the equation of a circle through the point (1, 2) and the intersections of the circles,

$$2x^2 + 2y^2 - 3x - 4y - 1 = 0 \text{ and}$$

$$3x^2 + 3y^2 - 8x - y - 4 = 0.$$

Using [368],

$$2x^2 + 2y^2 - 3x - 4y - 1 + k(3x^2 + 3y^2 - 8x - y - 4) = 0.$$

Since the point (1, 2) is on the locus, its coordinates must satisfy the equation of the locus; therefore,

$$2 + 8 - 3 - 8 - 1 + k(3 + 12 - 8 - 2 - 4) = 0,$$

whence

$$k = 2.$$

Therefore, the required equation is

$$2x^2 + 2y^2 - 3x - 4y - 1 + 2(3x^2 + 3y^2 - 8x - y - 4) = 0, \text{ or}$$

$$8x^2 + 8y^2 - 19x - 6y - 9 = 0.$$

**762. Length of Tangent.**—Let  $t$  be the length of the tangent  $TP_0$  to the circle whose center is at  $C(h, k)$  and whose radius is  $r$ .

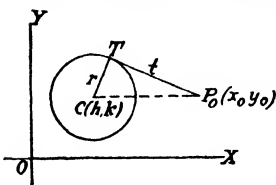

FIG. 416.

From the right triangle  $CTP_0$ ,

$$t^2 = CP_0^2 - r^2.$$

Using the distance formula [329],

$$t^2 = (x_0 - h)^2 + (y_0 - k)^2 - r^2.$$

$$[369] \quad t = \sqrt{(x_0 - h)^2 + (y_0 - k)^2 - r^2}.$$

Note that the expression under the radical is the same as the form [362] of the circle, with the coordinates of the point  $P_0(x_0, y_0)$  substituted for the variables  $x$  and  $y$ .

This being the case, we can then substitute the general equation under the radical, so that

$$[370] \quad t = \sqrt{x_0^2 + y_0^2 + \frac{D}{A}x_0 + \frac{E}{A}y_0 + \frac{F}{A}}.$$

EXAMPLE.—Find the length of the tangent from (5, 6) to the circle,

$$x^2 + y^2 - 4x + 6y - 3 = 0.$$

Substituting in [370],

$$t = \sqrt{5^2 + 6^2 - 4 \cdot 5 + 6 \cdot 6 - 3} = \sqrt{74}.$$

THE ELLIPSE

763. Article 745 on Conics states that if the ratio  $e$  is less than unity, the conic is an ellipse.

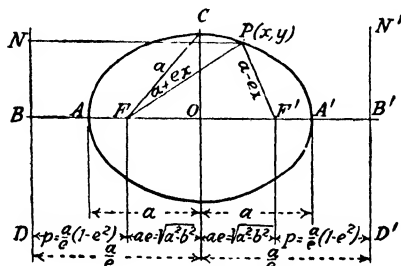

FIG. 417.

764. To Find Equation of Ellipse.—If  $P(x, y)$  is any point on the curve, we have

$$FP = e \cdot NP,$$

where  $F$  is the focus and  $ND$  the directrix.

Divide  $FB$  internally at  $A$  and externally at  $A'$  in the ratio of  $e$  to 1 (see Art. 717). Thus,

$$\frac{B}{A} \quad \frac{F}{A'}$$

Then

$$\frac{FA}{AB} = e, \quad FA = e \cdot AB. \tag{1}$$

$$\frac{FA'}{A'B} = -e, \quad FA' = e \cdot BA'. \tag{2}$$

Locate the origin midway between  $A$  and  $A'$ .

Then subtract (1) from (2);

$$FA' - FA = e(BA' - AB).$$

$$AF + FA' = e(BA + BA').$$

$$AA' = e(BA + BA + AO + OA').$$

Let  $AA' = 2a$ ; then

$$2a = e(2 \cdot BA + 2 \cdot AO) = e(2 \cdot BO).$$

$$BO = \frac{a}{e}.$$

Adding (1) and (2),

$$\begin{aligned}FA + FA' &= e(AB + BA'). \\2 \cdot OF &= eA'A = 2ae. \\ \therefore OF &= ae.\end{aligned}$$

If we consider  $O$  as the origin and  $OB$  and  $OC$  as the  $X$ - and  $Y$ -axes, then from the figure, the coordinates of the focus  $F$  are  $(-ae, 0)$ .

From the relation,

$$PF = e \cdot NP, \quad NP = x + BO.$$

Squaring,

$$\overline{PF}^2 = e^2 \cdot \overline{NP}^2 = e^2 \left(x + \frac{a}{e}\right)^2. \quad (3)$$

From the distance formula [329],

$$PF^2 = (x + ea)^2 + y^2. \quad (4)$$

Then (3) = (4), or

$$(x + ea)^2 + y^2 = e^2 \left(x + \frac{a}{e}\right)^2,$$

which reduces to

$$(1 - e^2)x^2 + y^2 = a^2(1 - e^2). \quad (5)$$

We can find the  $Y$ -intercept  $b$  or the semiminor axis by equating  $x$  to 0; then  $y = b$ .

Substituting these values of  $x$  and  $y$  in (5),

$$\begin{aligned}b^2 &= a^2(1 - e^2), \text{ or} \\(1 - e^2) &= \frac{b^2}{a^2}.\end{aligned}$$

Substituting this value of  $(1 - e^2)$  in (5),

$$\frac{b^2}{a^2}x^2 + y^2 = b^2.$$

Dividing by  $b^2$ ,

$$[371] \quad \frac{x^2}{a^2} + \frac{y^2}{b^2} = 1,$$

which is the standard equation for the ellipse.

**765. Other Relations.**—From the figure,

$$\overline{CF}^2 = \overline{CO}^2 + \overline{OF}^2,$$

$\overline{CO}^2$  = square of  $Y$ -intercept =  $a^2(1 - e^2)$ .

$\overline{OF}^2 = a^2e^2$ ; then  $(-ae, 0)$  are the coordinates of the focus, and

$$\begin{aligned}\overline{CF}^2 &= a^2(1 - e^2) + a^2e^2. \\ &= a^2 - a^2e^2 + a^2e^2 = a^2.\end{aligned}$$

$\therefore CF = a$ .



Therefore, to locate the focus when the major and minor semi-axes are given with  $C$  as a center and  $a$  as a radius, strike arcs intersecting the  $X$ -axis. The intersections of the arcs with the  $X$ -axis locate the foci.

Since  $b^2 = a^2(1 - e^2) = a^2 - a^2e^2$ ; transposing,

$$a^2e^2 = a^2 - b^2, \text{ or } ae = \pm\sqrt{a^2 - b^2}.$$

$$p = \frac{a}{e} - ae = a\left(\frac{1}{e} - e\right) = \frac{a}{e}(1 - e^2).$$

The focus  $F'$  is at  $(ae, 0)$ .

The focus  $F$  is at  $(-ae, 0)$ .

NOTE.  $ae = \pm\sqrt{a^2 - b^2}$ .

The equation of the directrix  $ND$  is  $x = -\frac{a}{e}$ .

The equation of the directrix  $N'D'$  is  $x = \frac{a}{e}$ .

Note also that  $\frac{a}{e} = \frac{a^2}{\pm\sqrt{a^2 - b^2}}$ .

The equation of the ellipse can also be put into the form,

$$\frac{x^2}{a^2} + \frac{y^2}{a^2(1 - e^2)} = 1.$$

### 766. Second Focus and Directrix.

Take  $F'A' = FA$  and  $OB' = OB$ .

$N'B'$  parallel to  $NB$ .

$P.N'$  perpendicular to  $N'B'$ .

Then

$$F'P = e \cdot PN'.$$

$$\therefore \sqrt{(ae - x)^2 + y^2} = e\left(\frac{a}{e} - x\right) = a - ex.$$

Squaring,

$$(ae - x)^2 + y^2 = a^2 - 2aex + e^2x^2.$$

$$a^2e^2 - 2aex + x^2 + y^2 = a^2 - 2aex + e^2x^2.$$

$$(1 - e^2)x^2 + y^2 = a^2(1 - e^2),$$

which is the same as (5) Art. 764, and therefore reduces to

$$\frac{x^2}{a^2} + \frac{y^2}{b^2} = 1,$$

so that the equation of the ellipse is the same when referred to the second focus and directrix as though referred to the original focus and directrix.

**767. Conic Equation Reduced to Equation of Ellipse.**—The equation of the general conic is

$$(1 - e^2)x^2 + y^2 - 2px + p^2 = 0,$$

when referred to the system with  $ND$  as  $Y$ -axis and origin at  $B$ . Dividing by  $1 - e^2$  and completing the square in  $x$ , we get

$$\left(x - \frac{p}{1 - e^2}\right)^2 + \frac{y^2}{1 - e^2} = \frac{p^2 e^2}{(1 - e^2)^2}.$$

Now from the figure,

$$p = \frac{a}{e} - ae = \frac{a}{e}(1 - e^2),$$

or

$$\frac{p}{1 - e^2} = \frac{a}{e},$$

and hence our equation may be written,

$$\left(x - \frac{a}{e}\right)^2 + \frac{y^2}{1 - e^2} = a^2.$$

If we now move the origin from  $B$  to the point  $O$  whose coordinates are  $\left(\frac{a}{e}, 0\right)$ , this equation becomes

$$x'^2 + \frac{y^2}{1 - e^2} = a^2,$$

or

$$\frac{x'^2}{a^2} + \frac{y^2}{a^2(1 - e^2)} = 1,$$

or

$$\frac{x'^2}{a^2} + \frac{y^2}{b^2} = 1.$$

To find  $p$  in the ellipse equation,

$$p = \frac{a}{e}(1 - e^2) = \frac{b^2}{ae}.$$

Since

$$ae = \pm \sqrt{a^2 - b^2},$$

$$p = \frac{b^2}{ae} = \frac{b^2}{\pm \sqrt{a^2 - b^2}}.$$

Also,

$$\frac{p^2 e^2}{1 - e^2} = b^2.$$

$$p^2 = \frac{b^2}{e^2}(1 - e^2), p = \pm \frac{b}{e} \sqrt{1 - e^2} = \pm \frac{b^2}{ae} = \frac{b^2}{\pm \sqrt{a^2 - b^2}}.$$

Also, since  $a^2(1 - e^2) = b^2$ ,

$$1 - e^2 = \frac{b^2}{a^2}.$$

**768. Eccentricity  $e$  in Terms of the General Equation Coefficients.**—From Art. 765,

$$e^2 = \frac{a^2 - b^2}{a^2}.$$

If  $A < C$ , we have

$$e^2 = \frac{\frac{CD^2 + AE^2 - 4ACF}{4A^2C} - \frac{CD^2 + AE^2 - 4ACF}{4AC^2}}{\frac{CD^2 + AE^2 - 4ACF}{4A^2C}} \dots \text{See Art. [772].}$$

This reduces to

$$e^2 = \frac{C[CD^2 + AE^2 - 4ACF] - A[CD^2 + AE^2 - 4ACF]}{C[CD^2 + AE^2 - 4ACF]} \\ = \frac{C - A}{C}.$$

$$e = \pm \sqrt{\frac{C - A}{C}}.$$

From this,

$$1 - e^2 = \frac{A}{C},$$

provided that  $C$ , the coefficient of  $y^2$ , is greater than  $A$ , the coefficient of  $x^2$ . The major axis is on the  $X$ -axis.

If  $A$  is greater than  $C$ , the major axis is on the  $Y$ -axis and

[372] 
$$e = \pm \sqrt{\frac{A - C}{A}}.$$

From this,

$$1 - e^2 = \frac{C}{A}.$$

**EXAMPLE.**—Find the eccentricity  $e$  of the equation,

$$x^2 + 4y^2 = 16.$$

$$A = 1, C = 4.$$

$$e = \sqrt{\frac{C - A}{C}} = \sqrt{\frac{4 - 1}{4}} = \frac{1}{2} \sqrt{3}.$$

**769. Focal Radii.**—From the definition of the ellipse or from the relation expressed in Art. 764,

$$PF = e \cdot PN = e\left(\frac{a}{e} + x\right) \text{ (from Fig. 417)}. \quad (1)$$

Also, from Art. 766,

$$PF'_1 = e \cdot PN'_1 = e\left(\frac{a}{e} - x\right). \quad (2)$$

Adding (1) and (2),

$$\begin{aligned} PF + PF' &= e\left(\frac{a}{e} + x\right) + e\left(\frac{a}{e} - x\right) \\ &= 2a. \end{aligned}$$

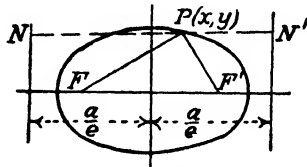

FIG. 418.

Therefore, the sum of the distances of any point on the ellipse from the foci is a constant and equal to the major axis.

**770. Major Axis on the Y-axis.**—If  $x$  and  $y$  are interchanged, then

$$[373] \quad \frac{y^2}{a^2} + \frac{x^2}{b^2} = 1.$$

The ellipse will then have the form shown in Fig. 419.

The  $Y$ -intercepts are at

$$(0, a) \text{ and } (0, -a).$$

The  $X$ -intercepts are at

$$(b, 0) \text{ and } (-b, 0).$$

The focus  $F$  is at  $(0, ae)$ .

The focus  $F'$  is at  $(0, -ae)$ .

The equation of the directrix  $ND$  is

$$y = \frac{a}{e}.$$

The equation of the directrix  $N'D$  is

$$y = -\frac{a}{e}.$$

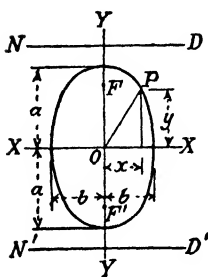

FIG. 419.

**771. Equation of Translated Ellipse.**—If the origin is translated from the center of the ellipse represented by

$$\frac{x^2}{a^2} + \frac{y^2}{b^2} = 1$$

to the point  $(-h, -k)$ , then the equation of the ellipse referred to the new origin is

$$[374] \quad \frac{(x - h)^2}{a^2} + \frac{(y - k)^2}{b^2} = 1.$$

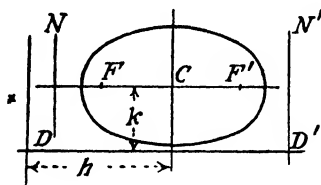

FIG. 420.

NOTE.—The origin may also be translated to  $(h, k)$  making the equation  $\frac{(x + h)^2}{a^2} + \frac{(y + k)^2}{b^2} = 1$ .

This is a more general standard form of the equation of the ellipse.

The center of the ellipse is at  $(h, k)$ .

The equation of the axes are  $x = h$  and  $y = k$ .

The focus  $F$  is at  $(h - ae, k)$ , or  $(h - \sqrt{a^2 - b^2}, k)$ .

The focus  $F'$  is at  $(h + ae, k)$ , or

$$(h + \sqrt{a^2 - b^2}, k).$$

The equation of the directrix  $ND$  is  $x = h - \frac{a}{e}$ , or

$$x = h - \frac{a^2}{\sqrt{a^2 - b^2}}.$$

The equation of the directrix  $N'D'$  is  $x = h + \frac{a}{e}$ , or

$$x = h + \frac{a^2}{\sqrt{a^2 - b^2}}.$$

To reduce an equation to the form,

$$\frac{(x - h)^2}{a^2} + \frac{(y - k)^2}{b^2} = 1,$$

simply means to complete the square of the terms in  $x$  and  $y$ .

**772. Form  $Ax^2 + Cy^2 + Dx + Ey + F = 0$ .**—This equation represents an ellipse with its axes parallel to the coordinate axes if  $A$  and  $C$  have like signs but different numerical values.

Completing the squares of the terms in  $x$  and  $y$ ,

$$A\left(x + \frac{D}{2A}\right)^2 + C\left(y + \frac{E}{2C}\right)^2 = \frac{CD^2 + AE^2 - 4ACF}{4AC}.$$

Dividing by the right member,

$$[375] \frac{\left(x + \frac{D}{2A}\right)^2}{\frac{CD^2 + AE^2 - 4ACF}{4A^2C}} + \frac{\left(y + \frac{E}{2C}\right)^2}{\frac{CD^2 + AE^2 - 4ACF}{4AC^2}} = 1.$$

If  $A > C$ , then the equation is of the form,

$$\frac{y^2}{a^2} + \frac{x^2}{b^2} = 1,$$

and has its major axis on the  $Y$ -axis.

Comparing [375] with the equation of the ellipse [371], we see that

$$\begin{aligned} h &= -\frac{D}{2A}, \quad k = -\frac{E}{2C}. \\ a^2 &= \frac{CD^2 + AE^2 - 4ACF}{4A^2C}. \\ b^2 &= \frac{CD^2 + AE^2 - 4ACF}{4AC^2}. \end{aligned}$$

If  $A > C$ , we interchange  $a^2$  and  $b^2$  and get the form,

$$\frac{y^2}{a^2} + \frac{x^2}{b^2} = 1.$$

Hence, the form  $Ax^2 + Cy^2 + Dx + Ey + F = 0$  can be transformed into one of the forms,

$$\frac{x^2}{a^2} + \frac{y^2}{b^2} = 1, \text{ or } \frac{y^2}{a^2} + \frac{x^2}{b^2} = 1,$$

by translating the origin to

$$\left(-\frac{D}{2A}, -\frac{E}{2C}\right),$$

which will transform the equation to one of the above forms.

EXAMPLE.— $4x^2 + 9y^2 - 16x + 18y - 11 = 0$ .

Collecting the  $x$  and  $y$  terms and completing the square,

$$4x^2 - 16x + 16 + 9y^2 + 18y + 9 = 11 + 16 + 9,$$

or

$$4(x - 2)^2 + 9(y + 1)^2 = 36.$$

Hence,

$$\frac{(x - 2)^2}{3^2} + \frac{(y + 1)^2}{2^2} = 1.$$

$$a^2 = 9, a = 3, b^2 = 4, b = 2, h = 2, k = -1.$$

$$ae = \sqrt{a^2 - b^2} = \sqrt{5}.$$

Focus  $F$  is at  $(h - ae, k)$ , or  $(2 - \sqrt{5}, -1)$ .

Focus  $F'$  is at  $(h + ae, k)$ , or  $(2 + \sqrt{5}, -1)$ .

The equations of the directrices are

$$x = 2 - \frac{9}{\sqrt{5}} \text{ and } x = 2 + \frac{9}{\sqrt{5}}.$$

**773. Major Axis of Ellipse Parallel to Y-axis. Origin Translated.**—The equation takes the form,

$$\frac{(y - k)^2}{a^2} + \frac{(x - h)^2}{b^2} = 1.$$

The center of the ellipse is at

$$(h, k).$$

The equation of the major axis is

$$x = h.$$

The focus  $F$  is at  $(h, k + ae)$  or

$$(h, k + \sqrt{a^2 - b^2}).$$

The focus  $F'$  is at  $(h, k - ae)$  or  $(h, k - \sqrt{a^2 - b^2})$ .

The equation of the directrix  $ND$  is

$$y = k - \frac{a}{c}, \text{ or } y = k - \frac{a^2}{\sqrt{a^2 - b^2}}.$$

The equation of the directrix  $N'D'$

$$\text{is } y = k + \frac{a}{c}, \text{ or } y = k + \frac{a^2}{\sqrt{a^2 - b^2}}.$$

$b$  is the semiminor axis, parallel to the  $X$ -axis.

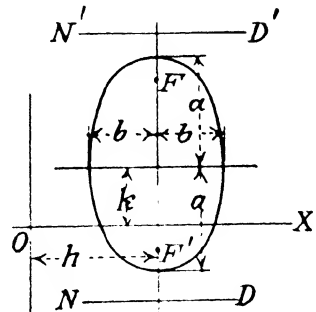

FIG. 421.

**774. Eccentric Angle of Ellipse.**—The circles drawn on the major and minor axes of the ellipse as diameters are called the *auxiliary circles*.

The equation of the ellipse is

$$\frac{x^2}{a^2} + \frac{y^2}{b^2} = 1.$$

The equation of the circle drawn on the major axis is

$$x^2 + y^2 = a^2.$$

The equation of the circle drawn on the minor axis is

$$x^2 + y^2 = b^2.$$

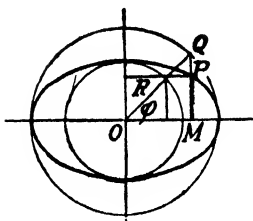

FIG. 422.

If  $\varphi$  is any angle at the center with initial line on the  $X$ -axis and the terminal side cutting the circles at  $R$  and  $Q$ , draw  $RP$  and  $QP$  parallel to the  $X$ - and  $Y$ -axes with intersection at  $P$ ; then  $OM = OQ \cos \varphi$  and  $MP = OR \sin \varphi$ , or  $x = a \cos \varphi$  and  $y = b \sin \varphi$ .

Substitute  $x$  and  $y$  values in the equation of the ellipse; then

$$\frac{a^2 \cos^2 \varphi}{a^2} + \frac{b^2 \sin^2 \varphi}{b^2} = \cos^2 \varphi + \sin^2 \varphi = 1.$$

Hence,  $P$  is a point on the ellipse.

**775. Equation of Ellipse in Polar Coordinates.**—If  $e < 1$  in

$$\rho = \frac{ep}{1 - e \cos \theta} \quad (\text{see Art. 747}),$$

the equation represents an ellipse.

For the other focus and the other directrix,

$$[376] \quad \rho = \frac{ep}{1 + e \cos \theta}$$

When  $\theta = 90^\circ$ , the value of  $2\rho$  is the length of the latus rectum.

$$p = \frac{a}{e} (1 - e^2).$$

$$\cos \theta = 0.$$

Substituting in [376],

$$\rho = \frac{e \cdot \frac{a}{e} (1 - e^2)}{1 + 0} = a(1 - e^2).$$

Multiplying through by  $a$ ,

$$a\rho = a^2(1 - e^2) = b^2.$$

$$\rho = \frac{b^2}{a}.$$

$$2\rho = \frac{2b^2}{a} = \text{length of latus rectum.}$$

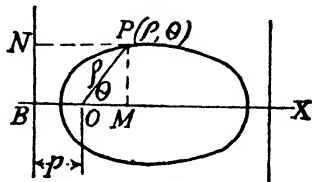

FIG. 423.





But

$$FF' = 2FO, FA = e \cdot AB, BO = \frac{a}{e}, AB = a - \frac{a}{e}.$$

$$2FO = 2\left(e \cdot AB + AB + \frac{a}{e}\right) = 2\left[e\left(a - \frac{a}{e}\right) + \left(a - \frac{a}{e}\right) + \frac{a}{e}\right].$$

$$= 2ae.$$

$$FO = ae.$$

Consider the origin at  $O$ ,  $OB$  the  $X$ -axis, and  $OC$  the  $Y$ -axis. Then, from the figure, the coordinates of the focus are  $F(-ae, 0)$ . The other focus is at  $F'(ae, 0)$ .

From the relation,

$$PF' = e \cdot N'P,$$

for any point  $P(x, y)$ ; squaring we have

$$\overline{PF'}^2 = e^2 \cdot \overline{N'P}^2 = e^2\left(x - \frac{a}{e}\right)^2.$$

From distance formula,

$$\overline{PF'}^2 = (x - ae)^2 + y^2.$$

Therefore,

$$e^2\left(x - \frac{a}{e}\right)^2 = (x - ae)^2 + y^2,$$

which reduces to

$$(1 - e^2)x^2 + y^2 = a^2(1 - e^2)$$

exactly as in the case of the ellipse. But in this instance we have  $e > 1$  and, hence, it is better to write the equation,

$$(e^2 - 1)x^2 - y^2 = a^2(e^2 - 1).$$

Let  $b^2 = a^2(e^2 - 1)$ , or

$$(e^2 - 1) = \frac{b^2}{a^2}.$$

Substituting above,

$$\frac{b^2}{a^2}x^2 - y^2 = b^2.$$

Dividing by  $b^2$ ,

$$[377] \quad \frac{x^2}{a^2} - \frac{y^2}{b^2} = 1,$$

which is the standard form of the equation of the hyperbola.

Since

$$b^2 = a^2(e^2 - 1) = a^2e^2 - a^2,$$

$$a^2e^2 = a^2 + b^2.$$

$$ae = \pm \sqrt{a^2 + b^2},$$

The focus  $F$  is at  $(-ae, 0)$ .

NOTE.  $ae = \pm\sqrt{a^2 + b^2}$ .

The focus  $F'$  is at  $(ae, 0)$ .

The equation of the directrix  $ND$  is  $x = -\frac{a}{e}$ .

The equation of the directrix  $N'D'$  is  $x = \frac{a}{e}$ .

NOTE.  $\frac{a}{e} = \frac{a^2}{\sqrt{a^2 + b^2}}$ .

**777. Foci on the Y-axis.**—If  $x$  and  $y$  are interchanged in

$$\frac{x^2}{a^2} - \frac{y^2}{b^2} = 1,$$

the foci are then on the  $Y$ -axis, and the equation becomes

[378]  $\frac{y^2}{a^2} - \frac{x^2}{b^2} = 1$ , or  $\frac{x^2}{b^2} - \frac{y^2}{a^2} = -1$ .

The focus  $F'$  is located at  $(0, ae)$ .  $ae = \sqrt{a^2 + b^2}$ .

The focus  $F$  is located at  $(0, -ae)$ .

The equation of the directrix

$$ND \text{ is } y = \frac{a}{e}$$

NOTE.  $\frac{a}{e} = \frac{a^2}{\sqrt{a^2 + b^2}}$ .

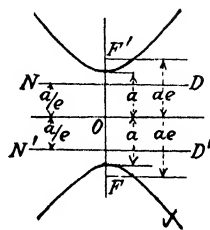

FIG. 425.

**778. Equation of Hyperbola from Conic Equation.**—The equation of the general conic is

$$(1 - e^2)x^2 + y^2 - 2px + p^2 = 0.$$

Since  $e > 1$ , the coefficient of  $x^2$  is negative, and

$$(e^2 - 1)x^2 - y^2 + 2px - p^2 = 0.$$

Dividing by  $(e^2 - 1)$  and completing the square of the terms in  $x$ ,

$$\left(x + \frac{p}{e^2 - 1}\right)^2 - \frac{y^2}{e^2 - 1} = \frac{p^2 e^2}{(e^2 - 1)^2}.$$

Now from the Fig. 424,

$$p = ae - \frac{a}{e} = \frac{a}{e}(e^2 - 1),$$

or

$$\frac{p}{e^2 - 1} = \frac{\frac{a}{e}(e^2 - 1)}{e^2 - 1} = \frac{a}{e}.$$

Hence, the equation may be written,

$$[379] \quad \left(x + \frac{a}{e}\right)^2 - \frac{y^2}{e^2 - 1} = a^2.$$

If we now move the origin from  $B$  to the point  $O$ , whose coordinates are  $\left(\frac{a}{e}, 0\right)$ , this equation becomes

$$x'^2 - \frac{y^2}{e^2 - 1} = a^2,$$

or 
$$\frac{x'^2}{a^2} - \frac{y^2}{a^2(e^2 - 1)} = 1,$$

or 
$$\frac{x'^2}{a^2} - \frac{y^2}{b^2} = 1.$$

**779. Focal Radii.**—From the equation (Art. 776),

$$PF = e \cdot PN. \quad (1)$$

$$= e\left(\frac{a}{e} + x\right).$$

$$PF' = e \cdot PN'. \quad (2)$$

$$= e\left(x - \frac{a}{e}\right).$$

Subtracting (2) from (1),

$$\begin{aligned} PF - PF' &= e\left(\frac{a}{e} + x\right) - e\left(x - \frac{a}{e}\right) \\ &= a + ex - ex + a = 2a. \end{aligned}$$

Therefore, the difference of the distances from any point on the hyperbola to the foci is a *constant* and equal to the transverse axis. (The transverse axis is the distance  $2a$  between the vertices.)

**780. Asymptotes.**—Let  $POP'$  be a line passing through  $O$ , the center of the hyperbola. The equation of the line is of the form,

$$y = mx.$$

If  $P$  is made to recede indefinitely by increasing  $x$ ,  $POP'$  will rotate about  $O$  and approach  $AA'$  as a limiting position. The lines  $AA'$  and  $BB'$  are called *asymptotes*.

The coordinates of the point  $P(x, y)$  must satisfy the equation of the hyperbola,

$$\frac{x^2}{a^2} - \frac{y^2}{b^2} = 1,$$

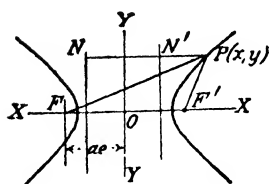

FIG. 426.

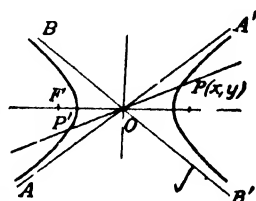

FIG. 427.

and the equation of the line,

$$y = mx.$$

Solving the two equations simultaneously,

$$x = \pm \frac{ab}{\sqrt{b^2 - a^2m^2}}.$$

Now as  $P(x, y)$  moves off along the curve,  $x$  becomes infinite and the denominator of the fraction; that is,

$$\sqrt{b^2 - a^2m^2}$$

must approach zero.

If  $b^2 - a^2m^2 = 0$ , then

$$m = \pm \frac{b}{a}.$$

Substituting in  $y = mx$ ,

$$y = \frac{b}{a}x \text{ and } y = -\frac{b}{a}x, \text{ or } y - \frac{b}{a}x = 0 \text{ and } y + \frac{b}{a}x = 0,$$

which are the equations of the asymptotes.

The equations of the asymptotes can be put into the same general form as the hyperbola by combining into the second-degree form (Art. 743).

Then

$$\left(y - \frac{b}{a}x\right)\left(y + \frac{b}{a}x\right) = 0, \text{ or } y^2 - \frac{b^2}{a^2}x^2 = 0,$$

or

$$\frac{b^2}{a^2}x^2 - y^2 = 0.$$

Dividing by  $b^2$ ,

$$\frac{x^2}{a^2} - \frac{y^2}{b^2} = 0.$$

**781. Conjugate Hyperbolas.**—Two hyperbolas are called *conjugate hyperbolas* if the transverse and conjugate axes of one are the conjugate and transverse axes, respectively, of the other.

When there are no first-degree terms in the equation of an hyperbola, the equation of its conjugate hyperbola is found by changing the signs of the coefficients of  $x^2$  and  $y^2$  in the given equation.

Thus, for  $16x^2 - y^2 = 16$ , the conjugate is

$$y^2 - 16x^2 = 16.$$

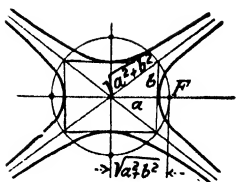

FIG. 428.

Then

$$\frac{x^2}{a^2} - \frac{y^2}{b^2} = 1 \text{ and } \frac{y^2}{b^2} - \frac{x^2}{a^2} = 1$$

are conjugate hyperbolas.

These two hyperbolas have the same asymptotes.

The foci are all at the same distance from the origin and this distance is equal to  $ae$ , or the foci lie on the circumference of a circle whose center is at the origin and whose radius is  $\sqrt{a^2 + b^2}$ .

**782. Translation of Equation of Hyperbola.**—The equation of the hyperbola can be translated in a manner similar to that used in the case of the ellipse (Art. 771).

By translating the origin from the center of hyperbola of standard form,

$$\frac{x^2}{a^2} - \frac{y^2}{b^2} = 1,$$

to the point  $(-h, -k)$  the translated form is

$$[380] \quad \frac{(x - h)^2}{a^2} - \frac{(y - k)^2}{b^2} = 1.$$

NOTE. The origin can also be translated to  $(h, k)$  and the equation will take the form  $\frac{(x + h)^2}{a^2} - \frac{(y + k)^2}{a^2} = 1$ .

The center, then, referred to the new axes, is at  $(h, k)$ .

The equation of the major axis is  $y = k$ .

The focus  $F'$  is located at

$$(h + ae, k).$$

The focus  $F$  is located at

$$(h - ae, k).$$

NOTE.  $ae = \sqrt{a^2 + b^2}$ .

The equation of the directrix  $ND$  is

$$x = h + \frac{a}{e}$$

The equation of the directrix  $N'D'$  is

$$x = h - \frac{a}{e}$$

NOTE.  $\frac{a}{e} = \frac{a^2}{\sqrt{a^2 + b^2}}$ .

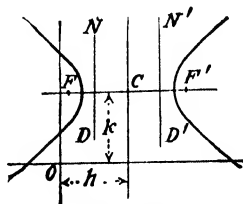

FIG. 429.

If the major axis is parallel to the  $Y$ -axis, the transformed equation takes the form,

$$[381] \quad \frac{(y - k)^2}{a^2} - \frac{(x - h)^2}{b^2} = 1.$$

The equation of the transverse axis is  $x = h$ .

The center, referred to the new axes, is at  $(h, k)$ .

The focus  $F'$  is located at

$$(h, k + ae).$$

The focus  $F$  is located at

$$(h, k - ae).$$

NOTE.  $ae = \sqrt{a^2 + b^2}$ .

The equation of the directrix  $ND$  is

$$y = k + \frac{a}{e}.$$

The equation of the directrix  $N'D'$  is

$$y = k - \frac{a}{e}.$$

NOTE.  $\frac{a}{e} = \frac{a^2}{\sqrt{a^2 + b^2}}$ .

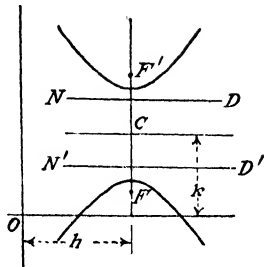

FIG. 430.

**783. Equilateral Hyperbola.**—If  $a = b$  in the equation,

$$\frac{x^2}{a^2} - \frac{y^2}{b^2} = 1,$$

then

$$x^2 - y^2 = a^2 [25].$$

This equation represents what is called an *equilateral hyperbola*.

The asymptotes make an angle of  $45^\circ$  with the axes and their equations are

$$y = x \text{ and } y = -x.$$

The eccentricity  $e$  is equal to  $\sqrt{2}$ , or 1.414.

The length of the latus rectum of the equilateral hyperbola is  $2a$ .

**784. Equation of Equilateral Hyperbola Referred to Its Asymptotes as Axes.**—The formulae of rotation are (Art. 793).

$$x = x' \cdot \cos(-45^\circ) - y' \cdot \sin(-45^\circ) \text{ and}$$

$$y = x' \cdot \sin(-45^\circ) + y' \cdot \cos(-45^\circ).$$

Then

$$x = \frac{1}{\sqrt{2}} (x' + y') \text{ and} \tag{1}$$

$$y = \frac{1}{\sqrt{2}} (y' - x'). \tag{2}$$

Substitute the values from (1) and (2) in the equation of the equilateral hyperbola,  $x^2 - y^2 = a^2$ ; then

$$\frac{1}{2}(x'^2 + 2x'y' + y'^2) - \frac{1}{2}(x'^2 - 2x'y' + y'^2) = a^2.$$

Dropping primes and reducing,

$$[382] \quad xy = \frac{a^2}{2}.$$

From this, it follows that if two variables change in such a way that their product is constant, the curve which represents them in rectangular coordinates is an equilateral hyperbola.

An hyperbola having the lines,

$$\begin{aligned} x + 2y + 3 &= 0 \text{ and} \\ 3x + 4y + 5 &= 0, \end{aligned}$$

for asymptotes will have an equation of the form,

$$(x + 2y + 3)(3x + 4y + 5) + k = 0,$$

while the equation of its conjugate hyperbola will be

$$(x + 2y + 3)(3x + 4y + 5) - k = 0.$$

If a second condition is imposed upon the hyperbola, *e.g.*, that it shall pass through the point (1, -1), then the value of *k* may be easily found.

Since the curve passes through the point (1, -1),

$$(1 - 2 + 3)(3 - 4 + 5) + k = 0.$$

$$\therefore k = -8.$$

The equation is

$$(x + 2y + 3)(3x + 4y + 5) - 8 = 0,$$

or

$$3x^2 + 10xy + 8y^2 + 14x + 22y + 7 = 0.$$

The equation of the conjugate hyperbola is

$$3x^2 + 10xy + 8y^2 + 14x + 22y + 23 = 0.$$

If the asymptotes of an hyperbola are chosen as the coordinate axes, their equations will be  $x = 0$  and  $y = 0$ , or

$$xy = 0.$$

Therefore, the equation of the hyperbola which differs from that of its asymptotes by a constant is

$$xy = k,$$

wherein the value of the constant *k* is to be determined by an additional assigned condition concerning the curve, *e.g.*, that it shall pass through a point, such as the vertex,

$$P\left(\frac{\sqrt{a^2 + b^2}}{2}, \frac{\sqrt{a^2 + b^2}}{2}\right).$$



The equation becomes

$$xy = \frac{a^2 + b^2}{4},$$

which is the equation of an hyperbola referred to its asymptotes as axes, ordinarily oblique.

**785. Form**  $Ax^2 + Cy^2 + Dx + Ey + F = 0$ .—If  $A$  and  $C$  have unlike signs, the above equation represents an hyperbola with axis parallel to the coordinate axis. This equation takes the same form as [375], or

$$\frac{\left(x + \frac{D}{2A}\right)^2}{\frac{CD^2 + AE^2 - 4ACF}{4A^2C}} + \frac{\left(y + \frac{E}{2C}\right)^2}{\frac{CD^2 + AE^2 - 4ACF}{4AC^2}} = 1.$$

Since  $A$  and  $C$  have unlike signs, then  $4A^2C$  and  $4AC^2$  will also have unlike signs.

If the second denominator is negative, the transverse axis is parallel to the  $X$ -axis.

If the first denominator is negative, the transverse axis is parallel to the  $Y$ -axis.

The form,  $Ax^2 + Cy^2 + Dx + Ey + F = 0$ , can be simplified by translating the origin to  $\left(\frac{-D}{2A}, \frac{-E}{2C}\right)$  into the forms,

$$\frac{x^2}{a^2} - \frac{y^2}{b^2} = 1 \quad [377]$$

and

$$\frac{y^2}{b^2} - \frac{x^2}{a^2} = 1 \quad [378].$$

**786. Eccentricity  $e$  in Terms of the General Equation of the Hyperbola.**—From Art. 776,

$$b^2 = a^2e^2 - a^2.$$

$$e^2 = \frac{b^2 + a^2}{a^2}.$$

$$e^2 = \frac{\pm \frac{CD^2 + AE^2 - 4ACF}{4AC^2} \mp \frac{CD^2 + AE^2 - 4ACF}{4A^2C}}{\frac{CD^2 + AE^2 - 4ACF}{4A^2C}}$$

$$= \frac{\pm A \mp C}{C}$$

$$e = \sqrt{\frac{\pm A \mp C}{C}} \text{ for transverse axis parallel to } XX.$$

For transverse axis parallel to  $YY$ , we have

$$e = \sqrt{\frac{\pm A \mp C}{A}}.$$

The double signs must be so adjusted that the value of  $e^2$  is positive. Since, in the hyperbola,  $A$  and  $C$  have unlike signs, the sum of the absolute values of  $A$  and  $C$  should be taken for the numerator and the absolute value of  $C$  for the denominator.

EXAMPLE.—Find the eccentricity  $e$  of the equation,

$$\frac{x^2}{16} - \frac{y^2}{48} = 1.$$

Arrange in the general form,

$$Ax^2 + Cy^2 + F = 0.$$

$$48x^2 - 16y^2 = 768.$$

$$A = 48, C = 16.$$

$$e = \sqrt{\frac{48 + 16}{16}} = \sqrt{4} = 2.$$

Note that from the equation of the equilateral hyperbola,

$$e = \sqrt{\frac{1+1}{1}} = \sqrt{2}.$$

**787. Polar Equation of Hyperbola.**—If  $e > 1$  in

$$\rho = \frac{ep}{1 - e \cos \theta} \text{ (Art. 747),}$$

the equation represents an hyperbola.

**788. Relation of Eccentricity  $e$  of Hyperbola and Ellipse with the Same Values of  $a$  and  $b$ .**

Let  $e$  represent the eccentricity of hyperbola and

$e_1$  represent the eccentricity of ellipse.

From Arts. 776 and 764,

$$e^2 - 1 = \frac{b^2}{a^2} \text{ and}$$

$$1 - e_1^2 = \frac{b^2}{a^2}.$$

Since  $a$  and  $b$  are equivalent in both formulae,

$$e^2 - 1 = 1 - e_1^2, \text{ or } e^2 + e_1^2 = 2.$$

The sum of the squares of the eccentricities equals 2.

EXAMPLES.—Compare the equations,

$$\frac{x^2}{16} - \frac{y^2}{4} = 1, \text{ an hyperbola, and}$$

$$\frac{x^2}{16} + \frac{y^2}{4} = 1, \text{ an ellipse.}$$

In both cases  $a = 4$  and  $b = 2$ .

Substituting values of  $a$  and  $b$  in

$$e^2 - 1 = \frac{b^2}{a^2} = \frac{4}{16},$$

$$e^2 = 1.25.$$

$$e = 1.118 \text{ (for hyperbola).}$$

Substituting values of  $a$  and  $b$  in

$$1 - e_1^2 = \frac{b^2}{a^2} = \frac{4}{16},$$

$$e_1^2 = \frac{3}{4} = .75.$$

$$e_1 = .866 \text{ (for ellipse).}$$

Then

$$e^2 + e_1^2 = 1.25 + .75 = 2.00.$$

Again since

$$e^2 + e_1^2 = 2,$$

the relation of  $e$  and  $e_1$  can be shown by a right triangle if  $a$  and  $b$  have the same values in the two equations.

By drawing the hypotenuse a constant length and keeping the angle  $A$  equal to  $90^\circ$ , the relation of  $e$  and  $e_1$  are graphically shown.

However,  $e$  must be greater than 1 for the equation to represent an hyperbola.

As  $e_1$  approaches zero,  $e$  approaches 1.414.

**789. Relation of Eccentricities of Ellipse and Hyperbola Having Same Values of  $a$  and  $p$ .**—Denote the eccentricity of the ellipse by  $e$  and of the hyperbola by  $e_1$ .

Assume the eccentricity of the ellipse as equal to the reciprocal of the eccentricity of the hyperbola,

or

$$e = \frac{1}{e_1}.$$

Then

$$ae = \frac{a}{e_1}$$

and

$$\frac{a}{e} = ae_1.$$

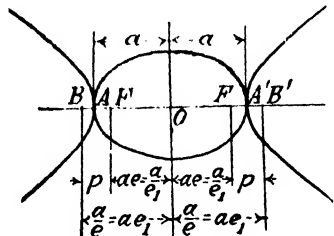

FIG. 431.

Therefore, the distance  $p$  between the foci and the directrices are equal in both cases, but the locations of the foci and directrices are interchanged.

**790.** If  $b$  in the equation of the ellipse is changed to  $b\sqrt{-1}$ , that is, to  $bi$ , the equation becomes the equation of an hyperbola. If this same substitution is made in the equations of tangents, normals, etc., of the ellipse, the equations represent tangents, normals, etc., of the hyperbola.

**791. Relations of  $p$  in Equation of Hyperbola.**—From Art. 778,

$$\frac{p^2 e^2}{(e^2 - 1)^2} = a^2.$$

Extracting the square root,

$$\frac{pe}{e^2 - 1} = a.$$

$$p = \frac{a}{e}(e^2 - 1) = \frac{a^2}{\sqrt{a^2 + b^2}} \cdot \frac{b^2}{a^2} = \frac{b^2}{\sqrt{a^2 + b^2}}.$$

## CHAPTER XXXV

### DISCUSSION OF GENERAL SECOND-DEGREE EQUATION

**792. Removal of First-degree Terms by Translation.**—The general equation is

$$Ax^2 + Bxy + Cy^2 + Dx + Ey + F = 0. \quad (1)$$

Move the origin to  $(h, k)$ ; then

$$\begin{cases} x = x' + h \\ y = y' + k \end{cases} \text{ where } x' \text{ and } y' \text{ are referred to the new axes.}$$

Equation (1) becomes

$$Ax'^2 + 2Ahx' + Ah^2 + Bx'y' + Bhy' + Bkx' + Bhk + Cy'^2 + 2Cky' + Ck^2 + Dx' + Dh + Ey' + Ek + F = 0.$$

Collecting,

$$Ax'^2 + Bx'y' + Cy'^2 + (2Ah + Bk + D)x' + (Bh + 2Ck + E)y' + (Ah^2 + Bhk + Ck^2 + Dh + Ek + F) = 0. \quad (2)$$

If values of  $h$  and  $k$  are chosen which will make the coefficients of  $x'$  and  $y'$  equal to zero, then

$$2Ah + Bk + D = 0. \quad (3)$$

$$Bh + 2Ck + E = 0. \quad (4)$$

Solving for  $h$  and  $k$ , we have

$$h = \frac{2CD - BE}{B^2 - 4AC} \text{ and}$$

$$k = \frac{2AE - BD}{B^2 - 4AC}.$$

If these values of  $h$  and  $k$  are substituted in the constant term of equation (2), or

$Ah^2 + Bhk + Ck^2 + Dh + Ek + F$ , the constant term becomes

$$[383] \quad \frac{-(4ACF + FDE - AE^2 - CD^2 - FB^2)}{B^2 - 4AC}. \quad (5)$$

The last term is very important in determining the nature of the locus and is called the *discriminant*.

Substituting these values of (3), (4), and (5) in (2), the general equation referred to the translated axes becomes

$$[384] \quad Ax'^2 + Bx'y' + Cy'^2 - \frac{4ACF + BDE - AE^2 - CD^2 - FB^2}{B^2 - 4AC} = 0.$$

Note that the first-degree terms have disappeared and that the coefficients of  $x^2$ ,  $xy$ , and  $y^2$  remain as before.

If the discriminate equals zero, then

$$Ax'^2 + Bx'y' + Cy'^2 = 0.$$

This case was discussed in Art. 210 and shown to be two straight lines.

**793. Rotation of Axes.**—Let  $OX$  and  $OY$  be rotated through the angle  $\theta$  until they assume the position of  $OX'$  and  $OY'$ . Then any point  $P$  whose coordinates referred to  $OX$  and  $OY$  are  $(x, y)$  will have coordinates  $(x', y')$  referred to  $OX'$  and  $OY'$ . Draw  $PM$  perpendicular to  $OX'$  and drop perpendiculars from  $P$  and  $M$  to both  $OX$  and  $OY$ .

$$\angle NPM = \theta.$$

$$x = OT - LT.$$

$$OT = x' \cos \theta.$$

$$LT = MN = y' \sin \theta.$$

$$x = x' \cos \theta - y' \sin \theta.$$

Similarly,

$$y = OR + RS.$$

$$OR = x' \sin \theta.$$

$$RS = PN = y' \cos \theta.$$

$$y = x' \sin \theta + y' \cos \theta.$$

Rotation of axes in general equation

$$Ax^2 + Bxy + Cy^2 + Dx + Ey + F = 0 \quad [13].$$

When equations of rotation are

$$x = x' \cos \theta - y' \sin \theta \text{ and}$$

$$[385] \quad y = x' \sin \theta + y' \cos \theta.$$

Substitute in general equation [13]

$$\begin{array}{l} A \cos^2 \theta \\ B \sin \theta \cos \theta \\ C \sin^2 \theta \end{array} \left| \begin{array}{l} -2A \sin \theta \cos \theta \\ 2C \sin \theta \cos \theta \\ x'^2 - B \sin^2 \theta \\ B \cos^2 \theta \end{array} \right| \begin{array}{l} A \sin^2 \theta \\ -B \sin \theta \cos \theta \\ x'y' \\ C \cos^2 \theta \end{array} \left| y'^2 \right.$$

$$\begin{array}{l} D \cos \theta \\ E \sin \theta \end{array} \left| x' \right. \begin{array}{l} E \cos \theta \\ -D \sin \theta \end{array} \left| y' + F = 0.$$

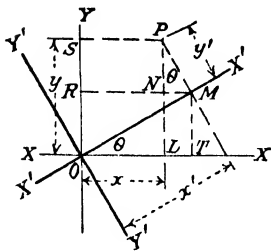

FIG. 432.

If  $\theta$  be so chosen that the coefficient of  $x'y'$  equals zero, or

$$B(\cos^2 \theta - \sin^2 \theta) = 2(A - C) \cos \theta \sin \theta,$$

then

$$B \cos 2\theta = (A - C) \sin 2\theta.$$

$$\frac{\sin 2\theta}{\cos 2\theta} = \tan 2\theta = \frac{B}{A - C}.$$

**794. Tests of Second-degree Equations for Locus.**—The first test for any equation of the second degree is the discriminant test (Art. 792).

If  $\Delta \equiv 4ACF + BDE - AE^2 - CD^2 - FB^2 = 0$ , the equation represents two lines, imaginary, intersecting, parallel or coincident. The proof of this test has already been established in Arts. 792 and 210.

If  $\Delta \neq 0$ , we have:

A parabola if  $B^2 - 4AC = 0$ .

An ellipse if  $B^2 - 4AC < 0$ .

An hyperbola if  $B^2 - 4AC > 0$ .

The  $B^2 - 4AC$  test follows (if  $\Delta \neq 0$ ) from the solution for  $y$  in Art. 208.

$$y = \frac{-(Bx + E) \pm \sqrt{(B^2 - 4AC)x^2 + 2(BE - 2CD)x + (E^2 - 4CF)}}{2C} \quad [38]$$

Except for the shearing, this is the same conic as

$$y = \pm \frac{\sqrt{(B^2 - 4AC)x^2 + 2(BE - 2CD)x + (E^2 - 4CF)}}{2C} \quad [39]$$

Rationalizing,

$$-4C^2y^2 + (B^2 - 4AC)x^2 + 2(BE - 2CD)x + (E^2 - 4CF) = 0.$$

From this it is apparent that if  $B^2 - 4AC = 0$ , the equation is quadratic in  $y$  and linear in  $x$  and represents a parabola.

If  $B^2 - 4AC < 0$  (that is, negative), the coefficients of  $x^2$  and  $y^2$  will have like signs and the locus will be an ellipse.

If  $B^2 - 4AC > 0$  (that is, positive), the coefficients of  $x^2$  and  $y^2$  will have unlike signs and the locus will be an hyperbola.

**795. Tangent (Secant Method).**—A tangent to a curve at a point  $P(x, y)$  is obtained as follows:

Take a second point  $P_2$  on the curve near  $P$ , and draw a line through these points. This line is called a *secant*.

If the point  $P_2$  approaches  $P$  along the curve, the line will rotate about  $P$ .

The limiting position of the secant, as  $P_2$  approaches infinitely near to  $P$ , is called the tangent at  $P$ .

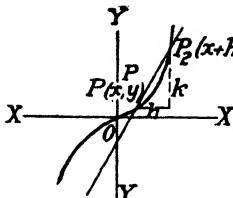

FIG. 433.

Begin by computing the slope of the secant line as in the following example:

Let the curve in Fig. 433 be  $5y = x^3$ .

The points  $P_0(x_0, y_0)$  and  $P_2(x_0 + h, y_0 + k)$  are on the curve and their coordinates must satisfy the equation of the locus. Therefore,

$$5y_0 = x_0^3. \quad (1)$$

$$5(y_0 + k) = (x_0 + h)^3. \quad (2)$$

$$5y_0 + 5k = 3x_0^2h + 3x_0h^2 + h^3 + x_0^3. \quad (3)$$

Subtracting (1) from (3),

$$5k = 3x_0^2h + 3x_0h^2 + h^3.$$

$$k = \frac{3x_0^2h + 3x_0h^2 + h^3}{5}.$$

$$\text{slope} = \frac{k}{h} = \frac{3x_0^2 + 3x_0h + h^2}{5}. \quad (4)$$

As  $P_2$  approaches  $P_0$ ,  $h$  and  $k$  approach zero. The slope of the tangent  $m$  can then be found by letting  $h$  and  $k$  approach zero in

$$\text{slope } m = \frac{3x_0^2 + 3x_0h + h^2}{5} \text{ approaches } \frac{3x_0^2}{5}, \quad (5)$$

and this is, therefore, the slope of the tangent.

The equation of a line in the point-slope form is

$$y - y_0 = m(x - x_0) \quad (6)$$

Substituting (5) in (6) then gives

$$y - y_0 = \frac{3x_0^2}{5}(x - x_0).$$

**796. Tangents to conics** can be found by the same method (Art. 795) at any point  $P_0(x_0, y_0)$  for the following:

[386] Circle  $x^2 + y^2 = r^2$  is  $x_0x + y_0y = r^2$ .

[387] Parabola  $y^2 = 2px$  is  $y_0y = p(x + x_0)$ .

[388] Ellipse  $\frac{x^2}{a^2} + \frac{y^2}{b^2} = 1$  is  $\frac{x_0x}{a^2} + \frac{y_0y}{b^2} = 1$ .

[389] Hyperbola  $\frac{x^2}{a^2} - \frac{y^2}{b^2} = 1$  is  $\frac{x_0x}{a^2} - \frac{y_0y}{b^2} = 1$ .

The equation of the tangent to any conic at the point  $P_0(x_0, y_0)$  can be found by substituting

$$\begin{aligned} & x_0x \text{ for } x^2, \quad y_0y \text{ for } y^2, \\ & \frac{xy_0 + x_0y}{2} \text{ for } xy, \quad \frac{x + x_0}{2} \text{ for } x, \text{ and } \frac{y + y_0}{2} \text{ for } y. \end{aligned}$$



In the general equation,

$$Ax^2 + Bxy + Cy^2 + Dx + Ey + F = 0,$$

the equation of the tangent at the point  $P_0(x_0, y_0)$  is

$$[390] \quad Ax_0x + B\frac{x_0y + y_0x}{2} + Cy_0y + \frac{D}{2}(x + x_0) + \frac{E}{2}(y + y_0) + F = 0.$$

EXAMPLE 1.—Find the tangent to  $3x^2 - 4xy + 2y - 7 = 0$  at the point  $(1, -2)$ .

$$A = 3, B = -4, C = 0, D = 0, E = 2, F = -7, x_0 = 1, y_0 = -2.$$

Substituting in the above equation for the tangent gives

$$3 \cdot 1 \cdot x - 4 \frac{1 \cdot y - 2 \cdot x}{2} + 0 + 0 + \frac{2}{2}(y - 2) - 7 = 0,$$

which reduces to

$$3x - 2y + 4x + y - 2 - 7 = 7x - y - 9 = 0,$$

which is the equation of the required tangent.

EXAMPLE 2.—Find the equation of the tangent to the curve,

$$3x^2 - 2xy - y^2 + 3x - 4y - 3 = 0,$$

at the point  $(-3, 5)$ .

$$A = 3, B = -2, C = -1, D = 3, E = -4, F = -3, x_0 = -3, y_0 = 5.$$

Substituting in the above equation for the tangent gives

$$3(-3)x - 1(-3y + 5x) - 1(5y) + \frac{3}{2}(-3 + x) - 2(y + 5) - 3 = 0,$$

which reduces to

$$25x + 8y + 35 = 0,$$

which is the equation of the tangent sought.

EXAMPLE 3.—Find the tangent to

$$4x^2 + y^2 - 5x - 12y - 8 = 0$$

at the point  $(4, 6)$ .

$$A = 4, B = 0, C = 1, D = -5, E = -12, F = -8, x_0 = 4, y_0 = 6.$$

Substituting in the above equation for the tangent gives

$$4 \cdot 4x + 1(6y) - \frac{5}{2}(4 + x) - 6(6 + y) - 8 = 0,$$

which reduces to

$$27x - 108 = 0, \text{ or } x = 4,$$

which is the equation of the required tangent.

**797. Tangents to Conics in Terms of Slope.**—The equation of the tangent having a slope  $m$  to a

$$[391] \quad \text{Circle } x^2 + y^2 = r^2 \text{ is } y = mx \pm r\sqrt{m^2 + 1}.$$

$$[392] \quad \text{Parabola } y^2 = 2px \text{ is } y = mx + \frac{p}{2m}.$$

[393] Parabola  $x^2 = 2py$  is  $y = mx - \frac{pm^2}{2}$ .

[394] Ellipse  $\frac{x^2}{a^2} + \frac{y^2}{b^2} = 1$  is  $y = mx \pm \sqrt{a^2m^2 + b^2}$ .

[395] Hyperbola  $\frac{x^2}{a^2} - \frac{y^2}{b^2} = 1$  is  $y = mx \pm \sqrt{a^2m^2 - b^2}$ .

[396] Hyperbola  $\frac{x^2}{a^2} - \frac{y^2}{b^2} = -1$  is  $y = mx \pm \sqrt{b^2 - a^2m^2}$ .

[397] Hyperbola  $xy = c$  is  $y = mx \pm 2\sqrt{-cm}$ .

**798. Normals to Conics.**—The normal to a curve at the point  $P_1(x_1, y_1)$  is the line drawn perpendicular to the tangent at that point.

The equation of the normal can be found by finding the slope of the tangent at the given point and remembering that the slope of the normal will then be the negative reciprocal of the slope of the tangent and will pass through the same point on the curve, that is,  $P_1$ . Since its slope and a point on the normal are known, its equation may be written by using the slope-point form (Art. 726).

The equations for the normals to different conics are:

[398] Circle  $x^2 + y^2 = r^2$  is  $x_0y = xy_0$ .

[399] Parabola  $y^2 = 2px$  is  $y_0x + py = x_0y_0 + py_0$ .

[400] Ellipse  $\frac{x^2}{a^2} + \frac{y^2}{b^2} = 1$  is  $a^2y_0x - b^2x_0y = (a^2 - b^2)x_0y_0$ .

[401] Hyperbola  $\frac{x^2}{a^2} - \frac{y^2}{b^2} = 1$  is  $a^2y_0x + b^2x_0y = (a^2 + b^2)x_0y_0$ .

In the general equation,  $Ax^2 + Bxy + Cy^2 + Dx + Ey + F = 0$ , the equation of the normal at the point  $P_0(x_0, y_0)$  is

[402] 
$$y - y_0 = \frac{Bx_0 + 2Cy_0 + E}{2Ax_0 + By_0 + D}(x - x_0).$$

**799. Properties of Tangents and Normals to Conics.**—The

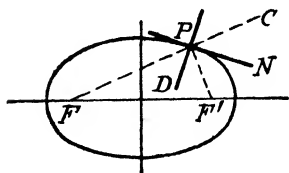

FIG. 434.

tangent and normal to an ellipse bisect, respectively, the external and internal angles formed by the focal radii at the point of contact.

In Fig. 434,

$$\angle FPD = \angle DPF' \text{ and}$$

$$\angle F'PN = \angle NPC.$$

Therefore, to draw a tangent and a normal to the ellipse at the point  $P$ , draw lines from  $P$  to the foci and bisect the internal and external angles formed by these lines.

From physics, the law of reflection of waves states that the angle of incidence equals the angle of reflection.

If a ceiling has the form of an ellipsoid, a whisper at  $F$  may be audible at  $F'$  but not at any other point adjacent to  $F'$ .



FIG. 435.

The tangent and normal to a parabola bisect, respectively, the internal and external angles formed by the focal radius of the point of contact and the line through that point parallel to the axis.

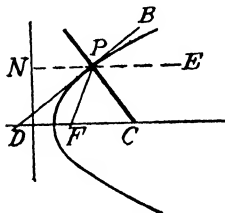

FIG. 436.

In Fig. 436,

$$\angle FPD = \angle DPN \text{ and}$$

$$\angle FPC = \angle CPE.$$

The principle of parabolic reflectors depends upon this property of the parabola.

All the rays of a light which is located at the focus are reflected from the parabola in lines that are parallel to the axis of the parabola.

The tangent and normal to an hyperbola bisect, respectively, the internal and external angles formed by the focal radii of the point of contact.

In Fig. 437,

$$\angle F'PA = \angle APF \text{ and}$$

$$\angle FPD = \angle DPC.$$

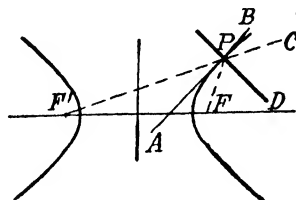

FIG. 437.

**800. Diameter of Conic.**—The locus of the midpoints of any system of parallel chords of a given conic is called a diameter. The chords are called the *chords of that diameter*.

This is best illustrated by an example.

Take the equation of the ellipse,

$$\frac{x^2}{a^2} + \frac{y^2}{b^2} = 1.$$

Let  $y = mx + c$  be the equation of one of the chords and let  $P_1(x_1, y_1)$  and  $P_2(x_2, y_2)$  be its points of intersection with the curve.

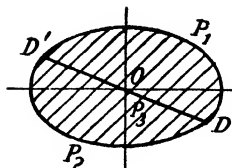

FIG. 438.

Let  $P_3(x_3, y_3)$  be the midpoint of the chord through  $P_1$  and  $P_2$ , so that

$$x_3 = \frac{x_1 + x_2}{2} \text{ and } y_3 = \frac{y_1 + y_2}{2}.$$

Find the coordinates of  $P_1$  and  $P_2$  by solving the equations of the ellipse and the chord simultaneously. Substituting the values of  $x_1, y_1, x_2,$  and  $y_2$  so found gives

$$x_3 = \frac{-a^2cm}{a^2m^2 + b^2}. \quad (1)$$

$$y_3 = \frac{b^2c}{a^2m^2 + b^2}. \quad (2)$$

Now by allowing  $c$  in the above equations to take on different values, we obtain the coordinates of the midpoints of each of the chords of the set, or  $x_3$  and  $y_3$ .

We can, therefore, find the locus of these midpoints by satisfying the conditions (1) and (2) without being dependent upon  $c$ .

We, therefore, eliminate  $c$  by dividing (1) by (2), which gives

$$\frac{x_3}{y_3} = -\frac{a^2}{b^2}m.$$

Therefore, the coordinates of the midpoints of a system of chords of slope  $m$  must satisfy the condition,

$$\begin{aligned} \frac{x}{y} &= -\frac{a^2}{b^2}m, \text{ or} \\ y &= -\frac{b^2}{a^2m}x. \end{aligned}$$

This is the equation of the diameter which bisects all chords of slope  $m$ .

In like manner the equations of the diameters which bisect chords of slope  $m$  may be shown to be as follows:

For parabola  $y^2 = 2px$  is  $y = \frac{2p}{m}$ .

For hyperbola  $\frac{x^2}{a^2} - \frac{y^2}{b^2} = 1$  is  $y = \frac{b^2}{a^2m}x$ .

**801. Properties of Diameters.**—From inspection of the diameter equation for the parabola, it will be seen that every diameter of the parabola is parallel to the axis of the parabola, or every line parallel to the axis of a parabola bisects some set of parallel chords and is a diameter of the curve.

The tangent at the end of a diameter is parallel to the bisected chords.

Every diameter of an ellipse passes through the center of the ellipse.

If one diameter, as  $AA'$ , bisects the chords  $b, c$ , etc., parallel to a second diameter  $BB'$ , then also the second diameter bisects the chords  $d, e$ , etc., parallel to the first diameter. Such diameters are called *conjugate diameters*.

The tangent at the end of a diameter is parallel to the conjugate diameter.

When we start with a system of chords of slope  $m$ , we get a diameter of slope,

$$m' = -\frac{b^2}{a^2m}$$

Hence,  $m$  and  $m'$  are the slopes of conjugate diameters when

$$m' = -\frac{b^2}{a^2m}, \text{ or } m = -\frac{b^2}{a^2m'}, \text{ or } mm' = -\frac{b^2}{a^2}$$

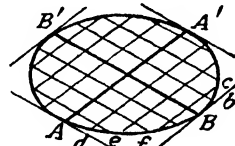

FIG. 439.

Every diameter of an hyperbola passes through the center of the hyperbola.

If  $AA'$  and  $BB'$  are conjugate diameters for the hyperbola  $CAD$  and  $C'A'D'$ , then they are also conjugate diameters for the conjugate hyperbola  $EBF$  and  $E'B'F'$ .

The tangent at the end of a diameter is parallel to the conjugate diameter.

**802. Subtangents and Subnormals.**—In Fig. 441, the projection of  $P_oT$  on the  $X$ -axis is called the *subtangent* at  $P_o$ . Like-

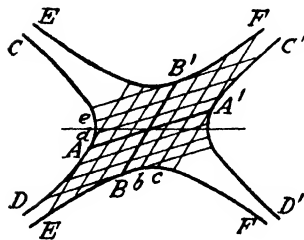

FIG. 440.

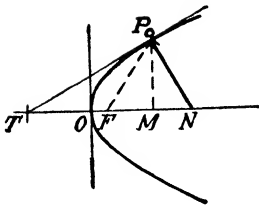

FIG. 441.

wise, the projection of  $P_0N$  on the  $X$ -axis is called the *subnormal* at  $P_0$ .

Subtangent is  $TM$ .

Subnormal is  $MN$ .

Consider the equation of the tangent to the parabola,  $y^2 = 2px$ , at the point  $P_0(x_0, y_0)$ , or

$$yy_0 = p(x + x_0). \quad [387]$$

To find the intersection of the tangent and the  $X$ -axis, let  $y = 0$ . Then

$$px + px_0 = 0.$$

$$x = -x_0 = OT. \quad \therefore TO = x_0.$$

But the subtangent is

$$TM = TO + OM = x_0 + x_0 = 2x_0.$$

The equation of the normal from the point  $P_0(x_0, y_0)$  is

$$y_0x + py = x_0y_0 + py_0. \quad \text{Let } y = 0, \text{ then,}$$

$$x = \frac{x_0y_0 + py_0}{y_0} = x_0 + p.$$

But  $ON = x_0 + p$ .

$$MN = ON - OM = x_0 + p - x_0 = p.$$

The subnormal for any point  $P_0(x_0, y_0)$  is a constant for a parabola and is equal to  $p$ .

A convenient graphical method of locating tangents, normals, subtangents, and subnormals is to describe a circle with the focal radius as radius and with the focus as a center. The circle cuts the  $X$ -axis at the intersections of the tangent and the normal with the  $X$ -axis.

By dropping a perpendicular from  $P_0$ , the subtangent and subnormal are obtained.

By using the same method as that used for the case of the parabola, the subtangent for any point  $P_0(x_0, y_0)$  on the ellipse is shown to be

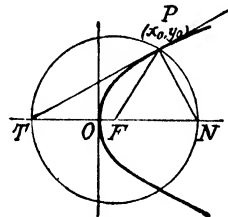

FIG. 442.

$$\text{Subtangent} = \frac{x_0^2 - a^2}{x_0}.$$

If a series of ellipses has the same major axis, tangents drawn to them at points having a common abscissa will cut the major axis (extended) in a common point  $N$ .

By drawing a circle with diameter equal to the major axis and using the same abscissa of  $P$  on the circle, a tangent to the circle at that point is easily drawn and the point  $N$  located.

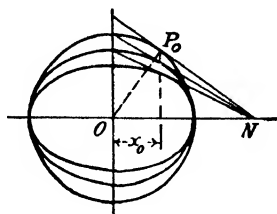

FIG. 443.

## CHAPTER XXXVI

### PARAMETRIC AND POLAR EQUATIONS

**803. Parametric Equations of a Curve.**—If the variable coordinates of a point on a curve are expressed separately as functions of a third variable, these equations are called *parametric equations of the curve*, and the third variable is called a *parameter*.

If an equation connecting the variables is known and a relation between the parameter and one of the variables is assumed, it is often possible to compute the relation between the parameter and the other variable. In this way, it is possible to represent a given curve by various sets of parametric equations. It is more usual, however, to assume some geometric relation between the variables and the parameter or to consider the time during which a point has been in motion as the parameter and to express the variables as functions of this time. In previous chapters, we have had some good examples of parametric equations, namely, in Art. 756,

$$\begin{aligned}x &= t \cdot v \cos \alpha \text{ and} \\y &= t \cdot v \sin \alpha - \frac{1}{2}gt^2,\end{aligned}$$

and again in Art. 800,

$$\begin{aligned}x &= \frac{-a^2cm}{a^2m^2 + b^2} \text{ and} \\y &= \frac{b^2c}{a^2m^2 + b^2}.\end{aligned}$$

**804. Parametric Equations of a Straight Line.**—From the equation of a straight line,

$$y - y_0 = \frac{m}{n}(x - x_0), \tag{1}$$

we know that the slope of the line is  $\frac{m}{n}$  and that the line passes through the point  $(x_0, y_0)$ .

Dividing (1) by  $m$ ,

$$\frac{y - y_0}{m} = \frac{x - x_0}{n}.$$



Suppose that we make each one of these ratios equal to a third variable,  $t$ ; then

$$\frac{x - x_0}{n} = t, \text{ or } x = x_0 + nt. \quad (2)$$

[403]

$$\frac{y - y_0}{m} = t, \text{ or } y = y_0 + mt. \quad (3)$$

The equations (2) and (3) are parametric equations of the curve represented by (1).

*Illustration.*—Put  $5y - 4x = 15$  in parametric form.

Then

$$5y = 4x + 15.$$

Let each side of the equation equal  $t$ ; then

$$t = 5y.$$

$$t = 4x + 15.$$

Note that by eliminating  $t$  between the two equations the equation returns to its original form.

We can also put the equations in the form,

$$5y - 5 = 4x + 10 = t.$$

$$t = 5y - 5 \text{ and } t = 4x + 10.$$

$$x = \frac{t}{4} - \frac{5}{2} \text{ and } y = \frac{t}{5} + 1.$$

Or

$$y = \frac{4}{5}x + 3.$$

$$t = y + 1 \text{ and } t = \frac{4}{5}x + 4,$$

from which

$$x = \frac{5}{4}t - 5.$$

$$y = t - 1.$$

We will make these relations clear by adopting an entirely new kind of coordinate axes. Assume three mutually perpendicular coordinate axes through the point  $O$ , similar to the coordinate axes used in solid analytical geometry. Pass intersecting planes through these axes, *i.e.*, a plane through the  $X$ - and  $Y$ -axes for relations between the variables  $x$  and  $y$ , a plane through the  $X$ - and  $T$ -axes for relations between  $x$  and  $t$ , and a plane through the  $Y$ - and  $T$ -axes for relations between  $y$  and  $t$ . Bear in mind

that we are concerned with the planes and not with space as we are in solid analytic geometry.

For convenience, represent the axes as shown in projection in Fig. 444.

On the  $XT$ -plane plot the equation,

$$x = \frac{5}{4}t - 5,$$

from the last forms of the equation given.

On the  $YT$ -plane, plot the equation,

$$y = t - 1,$$

and on the  $XY$ -plane plot the equation,

$$y = \frac{4}{5}x + 3.$$

Take any point on any of the lines and, by projection, the corresponding positions in any of the other lines can be determined.

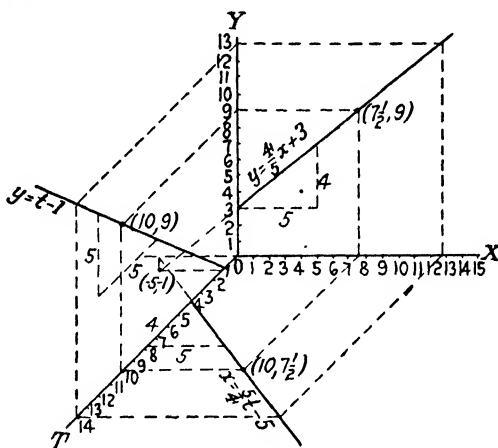

FIG. 444.

EXAMPLE.—Assume  $t = 10$  and projecting to

$$x = \frac{5}{4}t - 5,$$

we locate the coordinates  $(10, 7\frac{1}{2})$ , or  $x = 7\frac{1}{2}$ .

Now project to

$$y = t - 1,$$

or

$$y = 10 - 1 = 9.$$

From these two points on these lines, project into the  $XY$ -plane and we find the point  $(7\frac{1}{2}, 9)$  on the line,

$$y = \frac{4}{5}x + 3.$$

It will also be noted that the line.

$$y = \frac{1}{2}x + 3,$$

passes through the point  $(-5, -1)$ , and that its slope is  $\frac{1}{2}$ .

The slope of

$$x = \frac{5}{4}t - 5$$

with respect to the  $T$ -axis is  $\frac{5}{4}$ , and the slope of

$$y = t - 1$$

is 1.

If we are given any two of these lines, the third is easily found.

As a matter of fact, we can draw one of the parametric lines practically any place in the plane and find the other parametric equation from the conditions.

**805. Parametric Equations of Circle.**—Consider a circle with center at the origin and radius  $r$  generated by the point  $P(x, y)$ , starting on the axis and moving counterclockwise.

It is evident from the figure that

$$\cos \theta = \frac{x}{r},$$

and

$$\sin \theta = \frac{y}{r},$$

from which

[404]

$$x = r \cos \theta \text{ and}$$

$$y = r \sin \theta,$$

which are parametric equations of the circle with the angle  $\theta$  as the parameter.

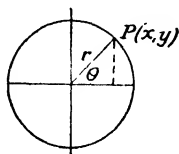

FIG. 445.

The relations of the circle and the above parametric equations can be shown graphically by plotting  $x = r \cos \theta$  on the  $X \theta$ -plane and the equation  $y = r \sin \theta$  on the  $Y \theta$ -plane and the circle on the  $XY$ -plane.

Several points are projected through the three curves. The circle has a radius of 6 (Fig. 446).

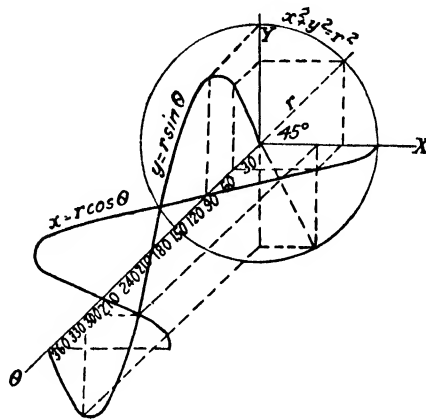

FIG. 446.

In like manner, the parametric equations of the parabola,

$$y^2 = 4x,$$

may be

$$x = t^2 \text{ and}$$

$$y = 2t.$$

For the ellipse,

$$\frac{x^2}{a^2} + \frac{y^2}{b^2} = 1,$$

parametric equations may be

$$x = a \cos \theta \text{ and}$$

$$y = b \sin \theta.$$

For the hyperbola,

$$\frac{x^2}{a^2} - \frac{y^2}{b^2} = 1,$$

parametric equations may be

$$x = a \sec \theta \text{ and}$$

$$y = b \tan \theta,$$

or

$$x = a \cosh t \text{ and}$$

$$y = b \sinh t \text{ (Art. 685).}$$

To plot a curve, give values to the parameter and compute the corresponding values of  $x$  and  $y$  and arrange the results in the form of a table.

**806. Parametric Equations of Parabola.**

**EXAMPLE.**—An aviator flying horizontally at the rate of 45 miles per hour wishes to hit a target on the ground. He estimates his height above the ground as 1000 feet. How far away must he be to hit the target; that is, what is the distance  $AB$ ?

Take the origin at the point of release of the bomb.

Let  $P(x, y)$  be the position of the bomb after  $t$  seconds.

If  $v$  represents the velocity in feet per second, the bomb will have moved  $vt$  feet horizontally after  $t$  seconds, or

$$x = vt.$$

But during  $t$  seconds, by physics, the bomb will have fallen a distance equal to  $\frac{1}{2}gt^2$  (neglecting wind, etc.).

Hence,

$$y = -\frac{1}{2}gt^2.$$

Hence,

$$t = \sqrt{\frac{2y}{g}}.$$

$$y = 1000, g = 32 \text{ (nearly).}$$

$$\therefore t = \sqrt{\frac{2000}{32}} = 7.906.$$

That is, it takes the bomb 7.906 seconds to reach the earth. It also travels ahead for the same length of time. Substituting 7.906 for  $t$  in

$$x = vt,$$

$v = 45$  miles per hour, or 66 feet per second.

$$\therefore x = 66 \times 7.906 = 522 \text{ feet.}$$

Note that the equations can also be changed from the parametric form by eliminating  $t$ , or

$$x^2 = -\frac{2v^2}{g}y.$$

**807. Involute of Circle.**—If a string is wound around a circle, the curve in the plane of the circle traced by a point on the string as it is rewound is called the *involute of the circle*.

Locate the  $X$ -axis through the center of the circle and the point  $P$  when it is in contact with the circle.

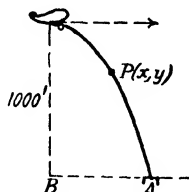

FIG. 447.

Let  $\theta$ , the angle through which the radius to the point of tangency of the string has rotated, be the parameter.

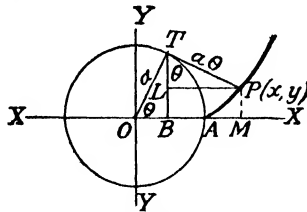

FIG. 448.

From the figure,

$$\begin{aligned}
 x &= OM = OB + BM = OB + LP. \\
 OB &= a \cos \theta, LP = TP \sin \theta = a\theta \sin \theta. \\
 y &= MP = BL = BT - LT. \\
 BT &= a \sin \theta, LT = TP \cos \theta = a\theta \cos \theta.
 \end{aligned}$$

Therefore, the equations are

[405] 
$$\begin{aligned}
 x &= a \cos \theta + a\theta \sin \theta \text{ and} \\
 y &= a \sin \theta - a\theta \cos \theta.
 \end{aligned}$$

**808. Example of Motion.**—If a taut string is unwound from the circle of radius  $a$  at the constant rate of  $k$  radians per second (angular velocity), then the angle for  $t$  seconds is  $kt$ , which, substituted in the parametric equations of the involute, gives the equations of motion for the point  $P(x, y)$ , or

$$\begin{aligned}
 x &= a(\cos kt + kt \sin kt) \text{ and} \\
 y &= a(\sin kt - kt \cos kt).
 \end{aligned}$$

**809. The Cycloid.**—The locus of a point  $P(x, y)$  on the circumference of a circle which rolls without slipping on a straight line is called a *cycloid*.

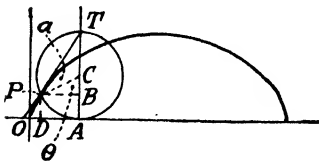

FIG. 449.

Let the origin  $O$  be at the point of contact of the locus with the  $X$ -axis.

Draw a circle at any point with a radius equal to  $a$ . Take the angle  $\theta$  as the radian angle through which the circle has rolled for the variable parameter. Then

$$PB = a \sin \theta, CB = a \cos \theta.$$

By the condition stated above,

$$OA = \text{arc } AP = a\theta.$$

From the figure,

$$\begin{aligned}
 x &= OD = OA - PB = a\theta - a \sin \theta, \\
 y &= DP = AC - CB = a - a \cos \theta, \\
 \therefore x &= a(\theta - \sin \theta) (\theta \text{ in radians}), \text{ and} \\
 y &= a(1 - \cos \theta),
 \end{aligned}$$

[406]

which are the equations of a cycloid in parametric form.

The tangent  $PT$  and the normal  $PA$  intersect the circle at the ends of the vertical diameter  $TA$  for any location of the circle.

The area under one arc is

$$A = 3\pi a^2.$$

The length of one arc is

$$S = 8a.$$

**810. Construction of Cycloid.**—Divide the given circle into any number of equal parts, as 1, 2, 3, 4, etc.

Lay off  $PP'$  equal to the circumference of the circle and divide it into the same number of equal parts.

Draw lines through the points of division on the circle, as 1-9, 2-8, 3-7, etc., parallel to  $PP'$ .

As the circle rolls forward a distance equal to one division as  $P9'$ , the point  $P$  moves from contact with  $PP'$  to a point on the first parallel line, 1-9.

For the second division, moved forward, the point  $P$  moves to a position on the second parallel line and so forth.

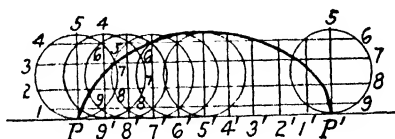

FIG. 450.

The location of  $P$  on these parallel lines can be determined in two ways, *i.e.*, by locating the center of the circle each time, and with radius equal to the radius of the circle by striking an arc which intersects the parallel lines, or in other words, by drawing just as much of the circle as is necessary; or the other method, simply by stepping off one division on the first parallel line, two divisions on the second line and so forth, until the center is reached. Then start at the opposite end of  $PP'$  and, moving towards the center, space the points as before. The reason for

this construction is that the circle moves ahead one division each time.

**811. The Trochoid.**—If any point on the radius of a rolling circle, or on the radius extended, is taken as the generating point, the locus is a *trochoid*.

If the distance from the point to the center of the circle which rolls on the  $X$ -axis is less than the radius of the circle, the curve is called a *prolate trochoid*, and if the distance is greater than the radius of the circle or radius produced, the curve is a *curtate* or *looped trochoid*.

The parametric equations in both cases are

$$[407] \quad \begin{aligned} x &= a\theta - b \sin \theta \text{ and} \\ y &= a - b \cos \theta. \end{aligned}$$

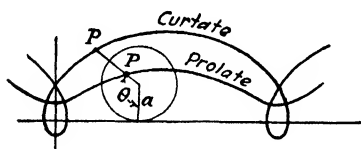

FIG. 451.

$b$  represents the distance from the point on the radius to the center of the rolling circle.

To construct trochoids, draw the generating circle in different locations as in the case of the cycloid, locate the center and

draw the radius (produced if necessary); then measure the distance  $b$  from the center for each location. Trace the curve through the points thus located.

**812. Hypocycloid and Epicycloid.**—A point on a circle which rolls on the inside of another *fixed* circle without slipping traces a curve called a *hypocycloid*. If the circle rolls on the *outside* of the fixed circle, the curve traced is called an *epicycloid*.

If  $r$  = radius of rolling circle and

$R$  = radius of fixed circle,

the equations of the hypocycloid in parametric form are

$$[408] \quad \begin{aligned} x &= (R - r) \cos \theta + r \cos \left( \frac{R - r}{r} \cdot \theta \right) \text{ and} \\ y &= (R - r) \sin \theta - r \sin \left( \frac{R - r}{r} \cdot \theta \right). \end{aligned}$$

The equations of the epicycloid are

$$[409] \quad \begin{aligned} x &= (R + r) \cos \theta - r \cos \left( \frac{R + r}{r} \cdot \theta \right) \text{ and} \\ y &= (R + r) \sin \theta - r \sin \left( \frac{R + r}{r} \cdot \theta \right). \end{aligned}$$



The parameter  $\theta$  is the variable angle in radians that a line passing through the centers of the circles makes with the  $X$ -axis. The  $X$ -axis passes through the starting point of the curve as shown in Figs. 452 and 453.

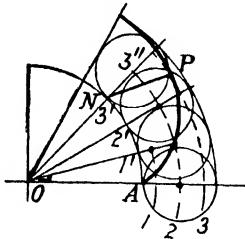

Epicycloid

FIG. 452.

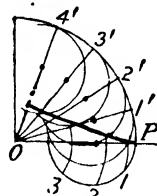

Hypocycloid

FIG. 453.

The curves are closed when  $R$  and  $r$  are commensurable.

**813. Construction of Epicycloids and Hypocycloids.**—Divide the semicircumference of the rolling circle into  $n$  equal parts as shown, the points of division being 1, 2, 3, 4, etc. With  $O$  as a center and  $O1, O2, O3$ , etc., as radii, strike arcs as shown.

Lay off arcs,  $A1', A2', A3'$ , etc., making them the same length as arcs 1-2, 2-3, etc., on the rolling circle. Draw the radii,  $O1', O2', O3'$ , etc.

As the rolling circle moves forward one division, the point  $P$  moves from the point of contact on the fixed circle to a point on the first outer concentric circle, and since the center of the circle is on the radius line  $O1'$ , its new location is readily drawn in a manner similar to that used in the case of the cycloid.

**814. Special Cases of Hypocycloid.**—If the radius of the rolling circle equals one-half the radius of the fixed circle, the locus is a straight line, e.g., a diameter of the fixed circle (Fig. 454).

If the radius of the rolling circle equals one-fourth the radius of the fixed circle, the four-pointed hypocycloid or *astroid* is the locus.

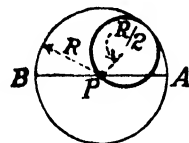

FIG. 454.

The equations in parametric form of the astroid are

$$x = \frac{3}{4}R \cos \theta + \frac{1}{4}R \cos 3\theta \text{ and}$$

$$y = \frac{3}{4}R \sin \theta - \frac{1}{4}R \sin 3\theta.$$

Its equation in rectangular coordinates is

$$x^{\frac{2}{3}} + y^{\frac{2}{3}} = c^{\frac{2}{3}}.$$

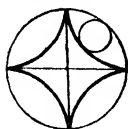

FIG. 455.

This equation may be obtained by eliminating  $\theta$  from the parametric equations above.

If, in an epicycloid, the radius of the rolling circle equals the radius of the fixed circle, the locus is a *cardioid*.

The parametric equations of the cardioid are

$$x = 2R \cos \theta - R \cos 2\theta \text{ and}$$

$$y = 2R \sin \theta - R \sin 2\theta.$$

The rectangular equation of the cardioid is

$$(x^2 + y^2 + 2Rx)^2 = R^2(x^2 + y^2).$$

The graph of the locus of the cardioid equation is constructed in a manner similar to that shown in the last article.

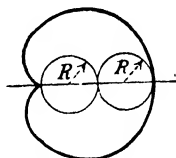

FIG. 456.

#### EQUATIONS IN POLAR COORDINATES

**815.** In examining polar equations, it is advisable to examine equations for:

1. Intercepts on the polar axis by putting  $\theta = 0^\circ, 180^\circ$ , or  $n \cdot 180^\circ$ .

2. Intercepts on the perpendicular to the polar axis by putting  $\theta = 90^\circ, 270^\circ$ , etc., or  $(2n - 1) \cdot 90^\circ$ .

3.  $\rho = 0$  gives values of  $\theta$  for which the curve passes through the pole.

4. Symmetry. Substitute  $-\rho$  for  $\rho$ . If the equation is unchanged, the curve is symmetrical with respect to the pole.

Substitute  $-\theta$  for  $\theta$ . If the equation is unchanged, the curve is symmetrical with respect to the polar axis.

If  $\pi - \theta$  is substituted for  $\theta$  without changing the equation, the curve is symmetrical with respect to the perpendicular to the polar axis.

5. Extent. Solve the equation for  $\rho$  in terms of  $\theta$ . Determine the maximum and minimum values of  $\rho$ . Determine the values of  $\theta$  for which  $\rho$  becomes infinite. Determine the values of  $\theta$  for which  $\rho$  becomes imaginary.

**816. Use of Polar Coordinates.**—When the required locus is described by the end point of a line of variable length, whose other extremity is fixed, polar coordinates may be employed to advantage.

**817. Spirals.**—A spiral is the locus of a point which revolves about a fixed pole, while its radius vector and its vectorial angle continually increase or decrease according to some law.

**818. Spiral of Archimedes.**—The locus of a point whose radius vector bears a constant ratio to the vectorial angle is a spiral of Archimedes.

The polar equation is

[410]  $\rho = k \cdot \theta$  ( $\theta$  expressed in radians).

The spiral of Archimedes may also be described as the locus of a point which moves with a uniform velocity along the radius vector, while the radius vector also revolves about  $O$  with uniform angular velocity.

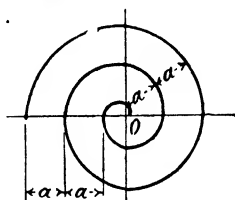

FIG. 457.

**819. The Reciprocal or Hyperbolic Spiral.**—The locus of a point whose radius vector varies inversely as the vectorial angle, *i.e.*, as the reciprocal of the vectorial angle, is a *reciprocal spiral*.

The polar equation is

[411]  $\rho = \frac{k}{\theta}$ , or  $\rho\theta = k$ .

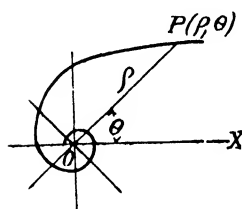

FIG. 458.

This reciprocal spiral begins at an infinite distance from the pole and constantly approaches the pole as it winds about it

without, however, ever reaching it. The curve has an asymptote parallel to the polar axis and at a distance  $k$  above it.

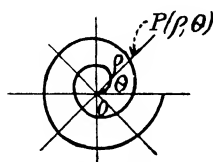

FIG. 459.

**820. The Parabolic Spiral.**—In this curve, the square of the radius vector varies as the vectorial angle.

The equation is

[412]  $\rho^2 = k \cdot \theta$ .

**821. The Lituus.**—In this curve, the square of the radius vector varies inversely as the vectorial angle. The equation is

[413]  $\rho^2 = \frac{k}{\theta}$ .

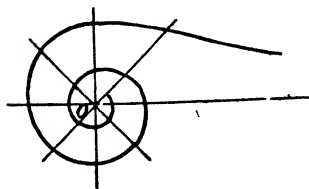

FIG. 460.

This curve has the polar axis as an asymptote.

The curve begins at infinity and constantly approaches the pole as it winds around it without, however, ever reaching it.

**822. Logarithmic Spiral.**—In this curve, the logarithms of the radii vectors are in the same ratio as the vectorial angles. The equation is

$$[414] \quad \log \frac{\rho}{a} = k\theta, \text{ or } \rho = ae^{k\theta}.$$

$\theta$  is expressed in radians.

$a$  is the value of  $\rho$  when  $\theta = 0$ .

If  $a = 2$ ,

When  $\theta = -2, -1, 0, 1, 2, 3, 4$ , etc.,

$$\rho = \frac{1}{4}, \frac{1}{2}, 1, 2, 4, 8, 16, \text{ etc.}$$

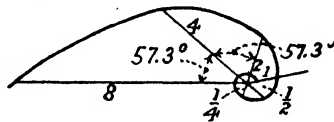

FIG. 461.

**823. The Lemniscate.**—The locus of a point  $P$ , the product of whose distances from two fixed points  $F$  and  $F'$  is a constant equal to  $\frac{1}{2}a^2$  is called the *lemniscate*.

The polar equation is

$$[415] \quad \rho^2 = a^2 \cos 2\theta.$$

Since the maximum value of  $\cos 2\theta$  is 1, the maximum value of  $\rho$  is  $a$ .

If  $\cos 2\theta$  is negative,  $\rho$  is imaginary. There is no part of the curve between the  $45^\circ$  and  $135^\circ$  lines.

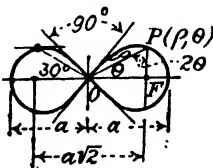

FIG. 462.

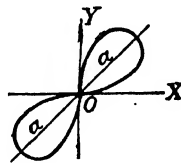

FIG. 463.

If  $-\theta$  is substituted for  $\theta$ , the equation is unchanged, and the curve is, therefore, symmetrical with respect to the polar axis.

When  $\rho = 0$ ,  $\cos 2\theta = 0$ ,  $\theta = 45^\circ, 135^\circ$ , and hence, the curve passes through the origin at these angles.

The equation  $\rho^2 = a^2 \sin 2\theta$  represents the lemniscate rotated about the origin through an angle of  $45^\circ$ .

**824. Three-leafed Rose.**

The equation is

$$[416] \quad \rho = a \sin 3\theta.$$

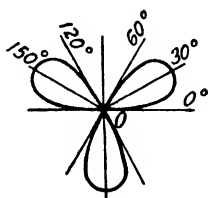

FIG. 464.

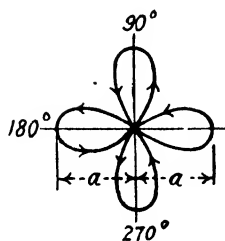

FIG. 465.

**825. Four-leafed Rose.**

The equation is

$$[417] \quad \rho = a \cos 2\theta.$$

## CHAPTER XXXVII

### EMPIRICAL EQUATIONS

**826. Determining Empirical Equations.**—A curve plotted from experimental data is called an *empirical curve* or *locus*.

An equation which represents a curve that approximates the empirical curve more or less accurately is called an *empirical equation*.

Many of the phenomena of change in nature have been found to be in accordance with one of three fundamental laws. These are: The Law of Power Functions (Art. 261), The Law of Organic Growth (Art. 365), sometimes called The Exponential or Compound Interest Law, and The Harmonic Law (Art. 613).

The power functions have the general form,

$$y - k = m(x - h)^n.$$

If  $n = 1$ , the equation is a straight line usually given in the form,

$$y = mx + b \text{ and } y = mx.$$

If  $n > 0$ , the equation is the parabolic type,

$$y - k = m(x - h)^n,$$

with vertex at  $(h, k)$  and includes the special forms,

$$y = mx^n, y = mx^n + b, y = cx^2 + bx + a.$$

If  $n < 0$ , the equation is of the hyperbolic type,

$$y - k = m(x - h)^{-n},$$

with center at  $(h, k)$  and includes the special forms,

$$y = \frac{a}{x^n}, y = \frac{a}{x^n} + b, xy = bx + ay.$$

The last form reduces to

$$\frac{a}{x} + \frac{b}{y} = 1.$$

**827.** In all cases where empirical equations are to be found, it is advisable first to plot the curve in rectangular coordinate from test data in order to get some idea of the shape of the locus.

and the nature of the law. If the locus approximates a straight line, then the equation  $y = mx + b$  may be assumed.

If only approximate relations of the variables are desired, the intercept  $b$  on the  $Y$ -axis, and the slope  $m$  may be measured by taking a straight line drawn so as to average the plotted points.

A more accurate determination is to assume two points on the straight line which seems to represent the observed data very well and to write the equation of the line through these two points (Art. 729).

If the points are  $(x_1, y_1)$  and  $(x_2, y_2)$  the line is

$$y - y_1 = \frac{y_2 - y_1}{x_2 - x_1}(x - x_1).$$

EXAMPLE.—In an experiment with a pair of gears, the pull  $P$  required to raise a weight  $W$  was observed to be as follows:

$W$	10	20	30	40	50	60	70	80	90	100
$P$	2.6	4.0	5.25	6.53	7.85	9.10	10.4	11.65	12.95	14.25

From observation of the plotted points, the locus seems to be a straight line and the points located by  $W = 10, P = 2.6$ , and  $W = 100, P = 14.25$  seem to be good points to substitute in the equation, or

$$y - 14.25 = \frac{14.25 - 2.6}{100 - 10}(x - 100),$$

or

$$y = .129x + 1.3,$$

or

$$P = .129W + 1.3.$$

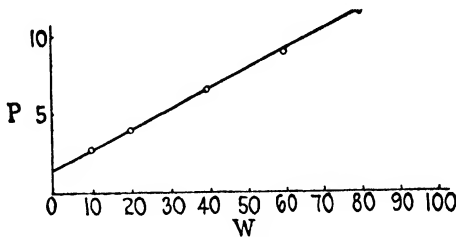

FIG. 466.

**828.** If the readings are made very accurately, and a more exact equation is desired, the following process taken from the method of least squares should be used.

Using the data from the previous problem, substitute each pair of values in the equation,  $y = mx + b$ , and ten equations result:

$$\begin{aligned}
 2.6 &= 10m + b. \\
 4 &= 20m + b. \\
 5.25 &= 30m + b. \\
 6.53 &= 40m + b. \\
 7.85 &= 50m + b. \\
 9.1 &= 60m + b. \\
 10.4 &= 70m + b. \\
 11.65 &= 80m + b. \\
 12.95 &= 90m + b. \\
 14.25 &= 100m + b.
 \end{aligned}$$

Multiply each equation by the coefficient of  $m$  and add the ten results together.

$$5713.7 = 38,500m + 550b$$

Multiply each of the ten equations by the coefficient of  $b$  and add

$$84.58 = 550m + 10b.$$

Solve the last two equations for  $m$  and  $b$ .

$$m = .1287$$

$$b = 1.380.$$

The equation is then

$$P = .1287W + 1.380.$$

This method of *least squares* can be expressed as follows:

*First.* Set up a series of equations of the first degree by substituting the observed values in the general equation.

*Second.* If as many equations can be formed as there are constants, solve to obtain values for the constants simultaneously. If there are more equations than there are constants to be determined, multiply each equation by the coefficient of the first constant in that equation and add the resulting equations to form a new equation. Proceed similarly for each constant and thus find as many equations as there are constant factors to be determined.

*Third.* Solve these new equations for the constants involved.

*Fourth.* Substitute the constants so found in the general equation and obtain the required empirical equation.

**829. Laws Reduced to Straight-line Laws.**—Equations which are not linear when plotted in rectangular coordinates, may be reduced to linear form by plotting to different coordinates which are functions of  $x$  or  $y$ . For instance, the equation,

$$y = a + bx^2,$$



will have a linear locus if  $x^2$  is represented by  $u$ .

The equation then becomes

$$y = a + bu,$$

which is linear in  $y$  and  $u$ .

To illustrate the law, we will assume the following observed relation between resistance and velocity to find the equation which represents the relation:

V	0	10	20	30	40	50
R	510	800	1720	3300	5300	8100

Plot these points and it will be seen that they lie, approximately, on a parabola. Therefore, the law is of the form,

$$y = a + bx^2.$$

Let  $u = v^2$ , and  $Y = R$ .

Tabulate.

u	100	400	900	1600	2500
R	800	1720	3300	5300	8100

Plot the straight line through the average points.

The empirical equation can now be found by determining the constants of the straight line and substituting in the general form.

For ordinary work, two points on the locus will be sufficient. These will determine two simultaneous equations of the form,

$$y = a + bu,$$

which will determine the constants,

$$\begin{aligned} 800 &= a + 100b \text{ and} \\ 8100 &= a + 2500b, \end{aligned}$$

from which

$$a = 500 \text{ and } b = 3.00.$$

Substituting in

$$R = a + bu,$$

or

$$R = 500 + 3u = 500 + 3v^2.$$

The two simultaneous equations can be plotted, using  $a$  as abscissae and  $b$  as ordinates. The intersection of the two lines gives the values of  $a$  and  $b$  which satisfy both equations.

In case greater accuracy is desired, the method of least squares (see previous article) should be used.

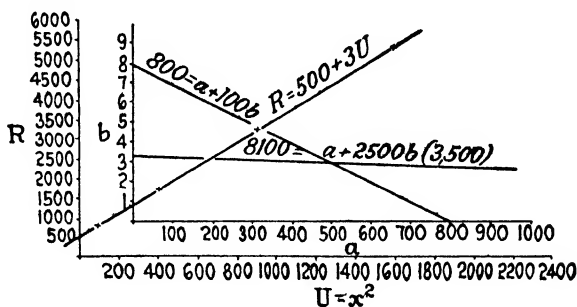

FIG. 467.

**830.** The method of reduction to straight-line form is useful for equations of various forms, as in the following examples:

If, after plotting the data on rectangular coordinate paper, the law is suspected of taking a form like

$$y^3 = ax^2 + b,$$

let  $v = y^3$  and  $u = x^2$  and plot the straight line to see if it meets the conditions. Numerous different trials may be required to find the correct law.

Equations of the form,

$$y = a + \frac{b}{x},$$

can be put into the straight-line form by means of the substitution,

$$u = \frac{1}{x}.$$

Equations of the form,

$$xy = bx + ay,$$

can be put into the straight-line form by dividing through by  $xy$  which changes the equation to

$$1 = \frac{a}{x} + \frac{b}{y}.$$

Put  $u = \frac{1}{x}$ , and  $v = \frac{1}{y}$ ,

or divide  $xy = bx + ay$  by  $x$ , which gives

$$y = b + \left(\frac{y}{x}\right).$$

Then let  $u = \frac{y}{x}$ , which will put the equation in the straight-line form between  $y$  and  $u$ .

Linear equations have two constants to determine, and two separate conditions are essential to determine the law, and the substitution of two observed readings in the general form will determine the law, since they give two simultaneous equations.

Only those laws which have but two constants are convertible into straight-line laws as will be readily observed.

**831. Power functions** of the general form,

$$y - k = a(x - h)^n,$$

are put into the straight-line form by means of logarithms, for

$$\log(y - k) = \log a + n \cdot \log(x - h).$$

By letting  $v = \log(y - k)$  and  $u = \log(x - h)$ , the straight-line formula is then

$$v = \log a \text{ (a constant)} + n \cdot u.$$

This is the principle underlying the use of logarithmic coordinate paper except that the  $x$  and  $y$  values are indicated on the graph instead of the  $u$  and  $v$  values.

Accordingly, when such a law as the above is suspected, we plot the variables on logarithmic paper.

EXAMPLE.—The following data are supposed to follow the law:

$$y = ax^n.$$

$x$	5	10	20	40	60	80	100
$y$	97	553	3130	17,700	48,800	100,000	175,000

The log form of the equation is

$$\log y = \log a + n \cdot \log x.$$

Let  $v = \log y$ ,  $C = \log a$ ,  $u = \log x$ .

The straight-line equation is then

$$v = n \cdot u + C.$$

$u (= \log x)$	.699	1.00	1.301	1.602	1.778	1.903	2.00
$v (= \log y)$	1.9868	2.743	3.496	4.248	4.688	5.000	5.243

Plot the points as shown in Fig. 468 with  $u$  as abscissa and  $v$  as ordinates.

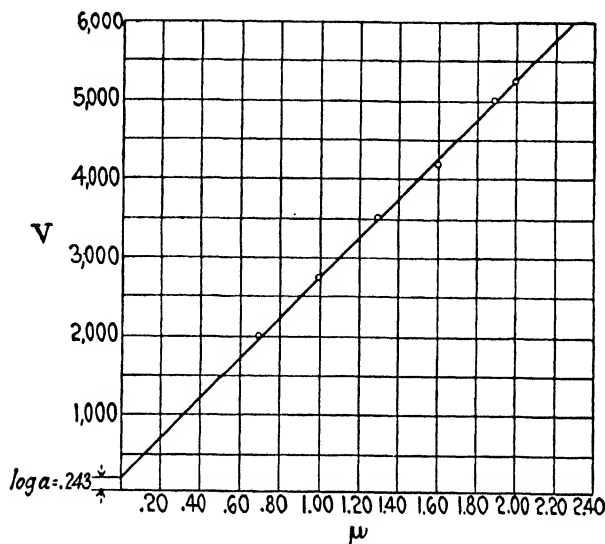

FIG. 468.

From the figure, the intercept on the  $V$ -axis to the scale of ordinates is .243, which according to the straight-line law is equal to the constant term  $C$ , or in this case,  $\log a$ .

The slope of the line measured according to the scales is 2.5 to 1; therefore,  $n = 2.5$ .

The straight-line equation in terms of  $v$  and  $u$  is

$$v = 2.5u + .243,$$

or

$$\log y = .243 + 2.5 \log x.$$

$$C = \log a = .243. \quad \therefore a = 1.75.$$

The equation from the log formula is then

$$y = 1.75x^{2.5}.$$

Standard log paper can also be used for plotting relations which can be expressed according to this law. When this paper is used, the values of the variables are plotted instead of the logs and all results read directly from the scales, since the logs are automatically taken when a point is located. Figure 469 shows a power function plotted on logarithmic coordinate paper

so that the slope of the line defines the exponent of the independent variable and the Y-intercept defines the coefficient of the independent variable.

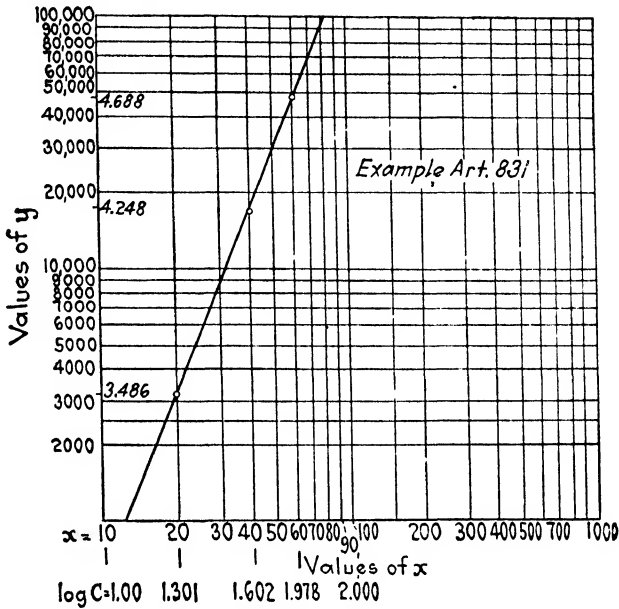

FIG. 469.

EXAMPLE.—Showing the application of the method of least squares to the power function,  $y = ax^n$ .

The following data satisfy an equation of the form,  $y = ax^n$ .

$x$	4	7	11	15	21
$y$	28.6	79.4	182	318	589
Tabulating logs,					
log $x = u$	.602	.845	1.04	1.18	1.32
log $y = v$	1.456	1.900	2.26	2.50	2.77

Forming equations of the form,

$$v = n \cdot u + C,$$

with  $v = \log y$ ,  $u = \log x$ , and  $C = \log a$ ,

$$1.456 = .602n + C.$$

$$1.900 = .845n + C.$$

$$2.26 = 1.04n + C.$$

$$2.50 = 1.18n + C.$$

$$2.77 = 1.32n + C.$$

Multiply each equation by the coefficient of  $n$  in each case and add:

$$\begin{array}{r}
 .876 = .362n + .602C \\
 1.606 = .714n + .845C \\
 2.352 = 1.084n + 1.04C \\
 2.94 = 1.383n + 1.18C \\
 3.662 = 1.748n + 1.32C \\
 \hline
 11.436 = 5.291n + 4.987C
 \end{array}$$

Adding the equations just as they stand, since the coefficients of  $C$  are all unity, we have

$$10.886 = 4.987n + 5C.$$

Solve for  $n$  and  $C$  in

$$\begin{array}{l}
 11.436 = 5.291n + 4.987C \text{ and} \\
 10.886 = 4.987n + 5.000C.
 \end{array}$$

from which

$$\begin{array}{l}
 n = 1.825, C = .357. \\
 C = \log a = .357. \\
 \therefore a = 2.276.
 \end{array}$$

The equation is then

$$y = 2.25x^{1.825}.$$

**832. Power functions with  $n$  negative**, or what is known as *hyperbolic functions*, can be solved in the same manner as previous problems.

The following table gives the volume  $V$  in cubic feet of 1 pound of saturated steam at a pressure of  $P$  pounds per square inch, and we desire to determine the law of expansion.

From experience, the law is suspected to be of the form,

$$PV^n = C,$$

which can be transformed into the form,

$$P = CV^{-n}.$$

$V$	26.43	22.40	19.08	16.32	14.04	12.12	10.51	9.147
$P$	14.7	17.53	20.80	24.54	28.83	33.71	39.25	45.49

Taking logs,

$\log V$	1.4221	1.3502	1.2806	1.2127	1.1473	1.0835	1.0216	.9612
$\log P$	1.1673	1.2430	1.3181	1.3900	1.4599	1.5277	1.5938	1.6580

The straight-line form is

$$\log P = -n \cdot \log V + C.$$

Another method known as the *method of averages* is often used and gives a more exact approximation than can be obtained

by the selection of two points on the straight line and the substitution of their coordinates in the general equation to determine two simultaneous equations which can be solved for the constants involved. The method is not so accurate as the method of least squares (Art. 828), however. The method follows:

Substitute all readings in the straight-line form and form the resulting equations into two groups. Add the separate groups to form two equations and solve these as before, simultaneously letting

$$\log P = v, \log V = u, \log a = C.$$

$$v = n \cdot u + C.$$

$$1.1673 = 1.4221n + C$$

$$1.2430 = 1.3502n + C$$

$$1.3181 = 1.2806n + C$$

$$1.3900 = 1.2127n + C$$

$$\hline 5.1184 = 5.2656n + 4C$$

$$1.4599 = 1.1473n + C$$

$$1.5277 = 1.0835n + C$$

$$1.5938 = 1.0216n + C$$

$$1.6580 = 0.9612n + C$$

$$\hline 6.2394 = 4.2136n + 4C$$

Solving the simultaneous equations,

$$5.1184 = 5.2656n + 4C.$$

$$6.2394 = 4.2136n + 4C.$$

$$n = -1.064.$$

$$C = \log a = 2.6764.$$

$$\therefore a = 475.$$

The equation is

$$P = 475V^{-1.064}, \text{ or } PV^{1.064} = 475.$$

If the plotted points fail to fall on a straight line when a curve of the form,  $y = ax^n$ , is plotted but curve upward as  $x$  increases, try subtracting some constant, as  $k$ , from the  $y$  values. If this straightens the graph of the locus, try different values of  $k$  until a satisfactory value gives a practically straight line. This, then, puts the equation in the form,

$$y - k = ax^n, \text{ or } y = ax^n + k.$$

Likewise, if the locus curves downward, add a value  $k$  to  $y$  and straighten the line, which gives an equation of the form,

$$y + k = ax^n, \text{ or } y = ax^n - k.$$

Another method of straightening the graph is to add some constant,  $\pm k$ , to all values of  $x$ . This has the effect of shifting all of the points to the right or left (by different amounts). If this method succeeds, the equation is of the form,

$$y = C(x - h)^n.$$

Some curves may be straightened by using both constants when either constant alone would fail to do it.

### 833. Empirical Equation of the Form

$$y = a + bx + cx^2 + dx^3 + \dots + qx^n.$$

By substituting experimental values in the above equation, enough simultaneous equations may be formed to determine the values of the constants  $a, b, c$ , etc.

There must be at least as many equations as there are constants to determine in order that they may be solved. As a general thing, three terms are all that are required for ordinary accuracy but it is well to use more if a greater degree of accuracy is desirable. Some of the terms also may be absent, or they may affect the result so little that they may be profitably neglected.

EXAMPLE.—Data,

$x$	1	2	3	4	5
$y$	14	64	182	398	742

Form four equations since four constants are assumed in

$$y = a + bx + cx^2 + dx^3.$$

$$14 = a + b + c + d.$$

$$64 = a + 2b + 4c + 8d.$$

$$182 = a + 3b + 9c + 27d.$$

$$398 = a + 4b + 16c + 64d.$$

Solving the above simultaneous equations for  $a, b, c$ , and  $d$ ,

$$a = 2, b = 3, c = 4, d = 5.$$

Form the equation,

$$y = 2 + 3x + 4x^2 + 5x^3.$$

834. The law of organic growth or the exponential law has the form,

$$y = ab^x, \text{ or } y = ae^{kx}.$$



The equation,  $y = ae^{kx}$ , can be put into the straight-line form by taking the logs of both sides,

$$\log y = kx \cdot \log e + \log a.$$

But the log of  $e$  is a constant and equal to .4343.

$$\log y = .4343kx + \log a.$$

This is a straight-line relation with respect to  $x$  and  $\log y$  and furnishes one method of plotting to determine the law.

By plotting on semilog paper, the locus of an equation of this form will be a straight line, since the ordinates are plotted according to a log scale and the abscissae according to a scale of equal parts.

EXAMPLE.—Beauchamp Tower's experiment on the relation of friction and temperature of bearings at constant speed gave data as shown in the table.

$t$	120	110	100	90	80	70	60
$\mu$	.0051	.0059	.0071	.0085	.0102	.0124	.0148

Assuming that the equation is of the form,

$$\mu = ae^{kt},$$

$$\log \mu = .4343kt + \log a.$$

Tabulating,

$t$	120	110	100	90	80	70	60
$\log \mu$	$\bar{3}.7076$	$\bar{3}.7709$	$\bar{3}.8513$	$\bar{3}.9294$	$\bar{2}.0086$	$\bar{2}.0934$	$\bar{2}.1703$

Make seven equations by substituting  $t$  and  $\log \mu$ . Then find two simultaneous equations by the law of averages as in the previous problems.

From this method, the equation is

$$\mu = .2113e^{-.0184t}.$$

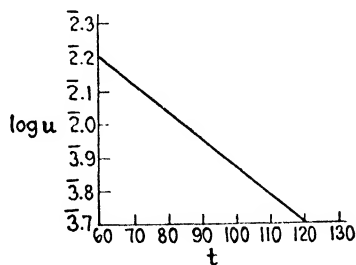

FIG. 470.

If a more exact equation is desired, use the method of least squares.

In Fig. 471 are shown the above data, plotted on semilog coordinate paper.

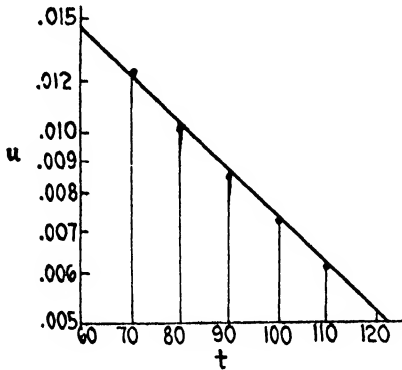

FIG. 471.

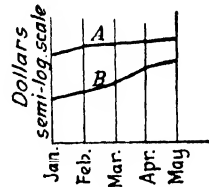

FIG. 472.

The semilog graph is very useful for business purposes. Since the ordinate  $y$  varies at a constant percentage rate, the curve shows where the greatest *percentage* gains were made.

If, for instance, the graph  $A$  in Fig. 472 represents the selling price of a product and  $B$  represents the cost graph over a period of time, the situation can be seen at a glance.

## CHAPTER XXXVIII

### APPLICATION OF COORDINATES TO THE GEOMETRY OF THREE DIMENSIONS

#### SOLID ANALYTICAL GEOMETRY

**835.** Solid analytical geometry treats of solids and surfaces in space by analytical methods and involves three dimensions or variables.

In the case where one of the variables is zero, the analytical relations between the remaining two are the same as in two variable analyses and the two bear consistent relations to each other.

For rectangular coordinates in three dimensions, three intersecting, mutually perpendicular planes are used. They are called the  $XOY$ ,  $YOZ$ , and  $ZOX$  coordinate planes and they intersect in three mutually perpendicular lines,  $OX$ ,  $OY$ , and  $OZ$ , called the coordinate axes.

For a point,  $P(x, y, z)$ , the usual method of determining the location is as shown in Fig. 473. The arrows indicate the positive directions on the three coordinate axes.

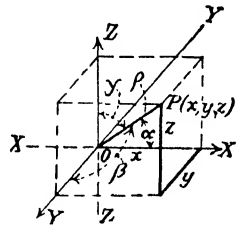

FIG. 473.

**836. Direction Angles or Polar Coordinates.**—Another method of locating a point in space is to give its radius vector, or its distance from the origin and the angles which the radius vector makes with the coordinate axes. These angles are called *direction angles*.

A point determined in this way is given as  $P(\rho, \alpha, \beta, \gamma)$ .

The projection of the radius vector on the coordinate axes gives equations connecting this system with the rectangular coordinate system, for

$$[418] \quad x = \rho \cos \alpha, \quad y = \rho \cos \beta, \quad z = \rho \cos \gamma.$$

We also have the relation from the rectangular parallepiped,

$$[419] \quad \rho^2 = x^2 + y^2 + z^2.$$

By combining the two sets of equations,

$$\rho^2 = \rho^2 \cos^2 \alpha + \rho^2 \cos^2 \beta + \rho^2 \cos^2 \gamma,$$

or

$$[420] \quad \cos^2 \alpha + \cos^2 \beta + \cos^2 \gamma = 1.$$

From  $x = \rho \cos \alpha$ ,  $y = \rho \cos \beta$ ,  $z = \rho \cos \gamma$ , and

$$\rho = \sqrt{x^2 + y^2 + z^2},$$

$$[421] \quad \cos \alpha = \frac{x}{\sqrt{x^2 + y^2 + z^2}} = \frac{x}{\rho}$$

$$[422] \quad \cos \beta = \frac{y}{\sqrt{x^2 + y^2 + z^2}} = \frac{y}{\rho}$$

$$[423] \quad \cos \gamma = \frac{z}{\sqrt{x^2 + y^2 + z^2}} = \frac{z}{\rho}$$

837. Distance and Direction between Two Points.—Let  $P_1$  and  $P_2$  be the two points.

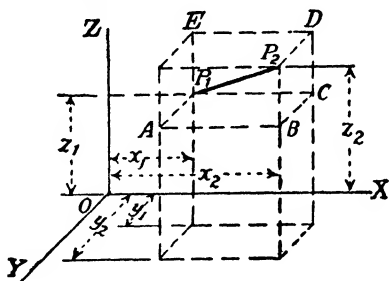

FIG. 474.

From Fig. 474,

$$\overline{P_1P_2}^2 = \overline{AB}^2 + \overline{CD}^2 + \overline{BC}^2.$$

$$AB = x_2 - x_1.$$

$$BC = y_2 - y_1.$$

$$CD = z_2 - z_1.$$

$$\begin{aligned} \overline{P_1P_2}^2 &= (x_2 - x_1)^2 + \\ &\quad (y_2 - y_1)^2 + \\ &\quad (z_2 - z_1)^2. \end{aligned}$$

If the distance  $P_1P_2$  equals  $d$ , then

$$[424] \quad d = \sqrt{(x_2 - x_1)^2 + (y_2 - y_1)^2 + (z_2 - z_1)^2}.$$

The direction of the line  $P_1P_2$  which does not pass through the origin is defined by the direction angles,  $\alpha, \beta, \gamma$ , of a line which passes through the origin and is parallel to  $P_1P_2$ , and which has the same positive direction.

The edges of the parallelepiped in Fig. 474 are parallel to the coordinate axes.

$$\alpha = CP_1P_2, \beta = AP_1P_2, \gamma = EP_1P_2.$$

Then

$$[425] \quad \cos \alpha = \frac{x_2 - x_1}{d}, \quad \cos \beta = \frac{y_2 - y_1}{d}, \quad \cos \gamma = \frac{z_2 - z_1}{d}.$$

Squaring and adding these three equations gives

$$\cos^2 \alpha + \cos^2 \beta + \cos^2 \gamma = 1.$$

**838. Angle between Two Radius Vectors or between Two Lines.**—Let the lines through the origin parallel to the given lines be  $OP_1$  and  $OP_2$  (Fig. 475) with  $\rho_1, \alpha_1, \beta_1, \gamma_1$  as the coordinates of  $P_1$ , and  $\rho_2, \alpha_2, \beta_2, \gamma_2$  as the coordinates of  $P_2$ . Also let  $\theta$  be the angle between  $OP_1$  and  $OP_2$ .

If the rectangular coordinates of  $P_1$  are  $(x_1, y_1, z_1)$ , then

$$OA = x_1, \quad AB = y_1, \quad BP_1 = z_1.$$

Project  $OP_1$  and  $OA + AB + BP_1$  on  $OP_2$ ; then

$$\rho_1 \cos \theta = x \cos \alpha_2 + y \cos \beta_2 + z \cos \gamma_2. \quad (1)$$

Project  $OP_1$  on the coordinate axes;

then

$$\begin{aligned} x &= \rho_1 \cos \alpha_1, \\ y &= \rho_1 \cos \beta_1, \\ z &= \rho_1 \cos \gamma_1. \end{aligned} \quad (2)$$

Substitute (2) in (1) and divide by  $\rho_1$ ;

then

$$\cos \theta = \cos \alpha_1 \cdot \cos \alpha_2 + \cos \beta_1 \cdot \cos \beta_2 + \cos \gamma_1 \cdot \cos \gamma_2.$$

If  $\alpha_1, \beta_1, \gamma_1$ , and  $\alpha_2, \beta_2, \gamma_2$  are the direction angles of two lines, the lines are parallel if

$$\alpha_1 = \alpha_2, \beta_1 = \beta_2, \gamma_1 = \gamma_2,$$

and perpendicular if

$$\cos \alpha_1 \cdot \cos \alpha_2 + \cos \beta_1 \cdot \cos \beta_2 + \cos \gamma_1 \cdot \cos \gamma_2 = 0.$$

**839. Dividing a Line in a Given Ratio.**—Suppose that we desire to divide the line  $P_1P_2$  at the point  $P_3$  in the ratio,

$$\frac{m_1}{m_2},$$

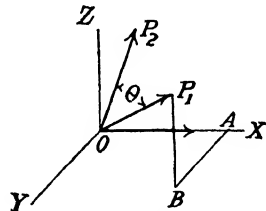

FIG. 475.

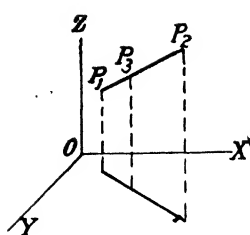

FIG. 476.

or

Then

$$P_1P_3 : P_3P_2 = m_1 : m_2.$$

$$x_3 = \frac{m_1x_2 + m_2x_1}{m_1 + m_2}$$

$$y_3 = \frac{m_1y_2 + m_2y_1}{m_1 + m_2}$$

$$z_3 = \frac{m_1z_2 + m_2z_1}{m_1 + m_2}$$

**840. Surfaces.**—The locus of a single equation in three variables is a surface. It will be readily seen that by giving different values to  $x$  and  $y$  in an assumed equation, such as

$$x^2 + y^2 - z = 10,$$

and computing  $z$ , the point  $P$  will generate a surface.

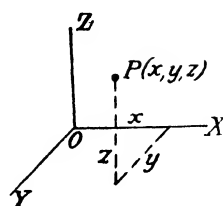

FIG. 477.

#### 841. Certain Equations in One Variable.

The equation  $z = 0$  represents the coordinate  $XOY$ -plane.

The equation  $y = 0$  represents the coordinate  $XOZ$ -plane.

The equation  $x = 0$  represents the coordinate  $YOZ$ -plane.

The equation  $z = k$  represents a plane parallel to the  $XOY$ -plane and at a distance equal to  $k$  units from it.

In a like manner, the equation  $x = k$  represents a plane parallel to the  $YOZ$ -plane and at a distance of  $k$  units from it, and the equation  $y = k$  represents a plane parallel to the  $XOZ$ -plane and at a distance of  $k$  units from it.

Any algebraic equation in one variable represents one or more planes parallel to a coordinate plane.

**842. Equations in two variables of the first degree** represent planes perpendicular to the coordinate plane of those variables.

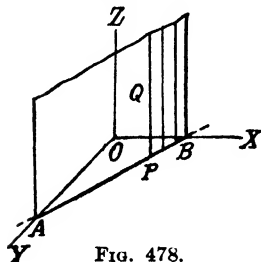

FIG. 478.

EXAMPLE.—Consider the equation,

$$3x + 2y = 5.$$

In the  $XOY$ -plane, the equation represents a straight line  $AB$  (Fig. 478).

If from any point  $P$  on  $AB$  a line be drawn perpendicular to the  $XOY$ -plane, any point  $Q$

on this perpendicular will have the same values for  $x$  and  $y$  as  $P$  and, therefore, satisfies the equation,

$$3x + 2y = 5.$$

Further, if  $PQ$  is moved along  $AB$  and always kept perpendicular to the  $XY$ -plane or parallel to the  $Z$ -axis, the coordinates of every point in the plane generated satisfy the equation  $3x + 2y = 5$ , which is evidently the equation of the plane.

### 843. Any Equation in Two Variables.

Consider

$$y^2 + z^2 = 25.$$

A point  $P(y, z)$  is on a circle in the  $YZ$ -plane. If  $PQ$  be drawn perpendicular to the  $YZ$ -plane, any point  $Q$  on this perpendicular will have the same values of  $y$  and  $z$  as  $P$  and, therefore, will satisfy the equation,  $y^2 + z^2 = 25$ . Since  $P$  may be any point on the circle, the locus of the equation is the surface of a circular cylinder whose elements are parallel to the  $X$ -axis and whose intersection with the  $YZ$ -plane is the circle shown.

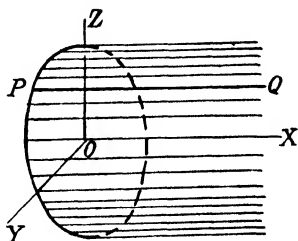

FIG. 479.

In like manner, the loci of the equations,

$$\frac{x^2}{a^2} + \frac{y^2}{b^2} = 1,$$

$$\frac{x^2}{a^2} - \frac{y^2}{b^2} = 1, \text{ and}$$

$$y^2 = 2pz,$$

are cylindrical surfaces whose elements are perpendicular to the plane of the variables involved and whose intersections with these planes are, respectively, an ellipse, an hyperbola, and a parabola. Similarly, any equation in two variables represents, in solid analytic geometry, a cylindrical surface. Since the elements are perpendicular to the plane of the variables, they are parallel to the axis of the third variable. The generating line  $PQ$  is called the *element*, and the locus on the coordinate plane is called the *directrix* of the cylindrical surface.

**844. Curves in Space.**—The locus of two simultaneous equations in three variables is a curve.

Since one equation in three variables is a surface, and since the coordinates of two simultaneous equations must satisfy both equations, it is evident that the only points which can satisfy these conditions are those which are on the intersection of the two surfaces. The intersection, then, is a curve which is represented by the two equations considered simultaneously.

**Lines in Space.**—Since  $y = k$  is the equation of a plane parallel to the  $XZ$ -plane, and since  $z = k$  represents a plane parallel to the  $XY$ -plane, their intersection is a line parallel to the  $X$ -axis.

Likewise,

$z = k$  and  $x = k$  represent a line parallel to the  $Y$ -axis.

$x = k$  and  $y = k$  represent a line parallel to the  $Z$ -axis.

Also,

$x = 0$  and  $y = 0$  are the equations of the  $Z$ -axis.

$x = 0$  and  $z = 0$  are the equations of the  $Y$ -axis.

$y = 0$  and  $z = 0$  are the equations of the  $X$ -axis.

See Art. 725 for a more general treatment of straight lines.

**845. Sphere.**—Let  $C (h, k, l)$  be the center of the sphere of radius  $r$ .

Since any point  $P (x, y, z)$  on the sphere is at a distance  $r$  from the center, then

$$CP = r.$$

From the distance formula [424]

$$[426] \quad r = \sqrt{(x - h)^2 + (y - k)^2 + (z - l)^2},$$

or

$$(x - h)^2 + (y - k)^2 + (z - l)^2 = r^2.$$

This is the equation of a sphere whose center is at the point  $C (h, k, l)$ , and whose radius is  $r$ .

If the center is at the origin, then  $h = 0$ ,  $k = 0$ , and  $l = 0$ , and the equation becomes

$$[427] \quad x^2 + y^2 + z^2 = r^2,$$

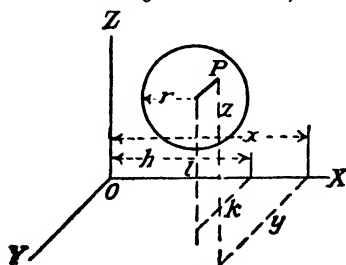

FIG. 480.



Expanding the equation,

$$(x - h)^2 + (y - k)^2 + (z - l)^2 = r^2,$$

it becomes, after collecting,

$$x^2 + y^2 + z^2 - 2hx - 2ky - 2lz + h^2 + k^2 + l^2 - r^2 = 0,$$

which is in the general form,

$$x^2 + y^2 + z^2 + Gx + Hy + Kz + L = 0.$$

By completing the squares in the latter equation, we have

$$[428] \quad \left(x + \frac{G}{2}\right)^2 + \left(y + \frac{H}{2}\right)^2 + \left(z + \frac{K}{2}\right)^2 = \frac{1}{4}(G^2 + H^2 + K^2 - 4L),$$

which is the same form as

$$(x - h)^2 + (y - k)^2 + (z - l)^2 = r^2,$$

with the coordinates of the center of the sphere as

$$h = -\frac{G}{2}, \quad k = -\frac{H}{2}, \quad l = -\frac{K}{2},$$

and the radius of the sphere,

$$r = \frac{1}{2}\sqrt{G^2 + H^2 + K^2 - 4L},$$

provided that  $G^2 + H^2 + K^2 - 4L > 0$ .

**846. Projections.**—A curve in space may have any number of surfaces pass through it. The equations of any two of these surfaces will define the curve.

Consider the two surfaces,

$$\begin{aligned} x^2 + y^2 + z^2 &= 25 \text{ and} \\ z &= 3. \end{aligned}$$

The former is the equation of a sphere with its center at the origin and of radius equal to 5. The latter equation represents a plane parallel to the  $XY$ -plane and 3 units above it (Fig. 481).

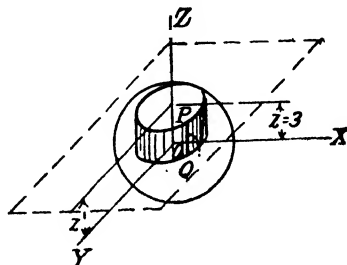

FIG. 481.

If the coordinates of any point satisfy both of the equations,  $z = 3$  and  $x^2 + y^2 + z^2 = 25$ , they will also satisfy the equation,

$x^2 + y^2 = 16$ , obtained by substituting  $z = 3$  in  $x^2 + y^2 + z^2 = 25$ .

Hence,  $x^2 + y^2 = 16$  represents a surface passing through the intersection of  $z = 3$  and  $x^2 + y^2 + z^2 = 25$ ; and it is evidently a cylindrical surface with elements parallel to the  $XY$ -plane. We can, therefore, say that the substitution of  $z = k$ , where  $k$  is a constant, in the equation of a surface will give the equation of a cylinder passing through the intersection of  $z = k$  and the surface, or the equation of the projection on the  $XY$ -plane of the intersection of  $z = k$  and the surface.

In this manner, the nature of the curve in which a plane parallel to one of the coordinate planes cuts a given surface is determined.

**847. Curve Projection on Coordinate Plane.**—Applying the reasoning of the previous article to finding the equation of the projection on the  $XY$ -plane of a curve defined by two equations, eliminate  $z$  between the two equations. The resulting equation is the equation of the projection on the  $XY$ -plane.

In like manner, to project on the  $XZ$ -plane, eliminate  $y$  between the two equations and to project on the  $YZ$ -plane, eliminate  $x$  between the two equations.

The curve can now be represented by two equations, each in two variables.

The projection of a locus on a coordinate plane is called the *trace* on that plane.

To find the equation of the intersection of a surface with the  $XY$ -plane, make  $z = 0$ ; with the  $XZ$ -plane, make  $y = 0$ ; and with the  $YZ$ -plane, make  $x = 0$ .

**EXAMPLE.**—Determine the nature of the curve in which the plane  $x = 4$  intersects the surface  $y^2 + z^2 = 4x$ .

Eliminate  $z$  by substituting  $z = 4$  in  $y^2 + z^2 = 4x$ , or

$$y^2 - 4x + 16 = 0.$$

We can consider the curve as given by

$$y^2 - 4x + 16 = 0,$$

$$z = 4,$$

or by

$$y^2 - 4x + 16 = 0,$$

$$y^2 + z^2 = 4x.$$

Taking the former, since  $z = 4$  represents a plane and  $y^2 - 4x + 16 = 0$  is a trace of the intersection with that plane in the  $XY$ -coordinate plane, we find that the locus is a parabola in that plane.

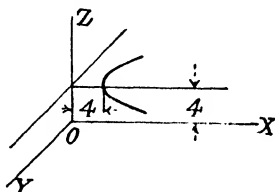

FIG. 482.

**848. Intercepts of a Surface on the Coordinate Axes.**—To find:

The intercept on the  $X$ -axis, make  $y = 0, z = 0$ .

The intercept on the  $Y$ -axis, make  $x = 0, z = 0$ .

The intercept on the  $Z$ -axis, make  $x = 0, y = 0$ .

It is advisable to examine a surface for symmetry by substituting  $-x$  for  $x$ ,  $-y$  for  $y$ ,  $-z$  for  $z$ .

If the equation is unchanged by the substitutions, the surface is, respectively, symmetrical with respect to the  $YZ$ ,  $XZ$ , and  $XY$  coordinate planes and symmetrical with respect to the  $X$ -,  $Y$ -, and  $Z$ -axes.

**849. Surfaces of Revolution.**—The surface traced by revolving any plane curve about a straight line in the plane as an axis is a *surface of revolution*. It follows that each plane section perpendicular to the axis is a circle, and the path of any point on the curve as it rotates is a circle.

Consider the ellipse,

$$\begin{aligned}x^2 + 4y^2 - 12x &= 0 \\z &= 0,\end{aligned}$$

rotated about the  $X$ -axis.

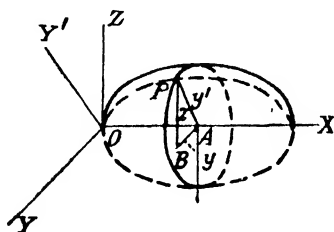

FIG. 483.

Let  $P(x, y, z)$  be any point on the surface generated.

Pass a plane through the axis  $OX$  and the point  $P$ , with  $OY'$  its intersection with the  $YZ$ -plane.

The equation of the ellipse referred to  $OX$  and  $OY'$  as coordinate axes is

$$x^2 + 4y'^2 - 12x = 0. \quad (1)$$

Pass a plane through  $P$  perpendicular to  $OX$ . Then in the triangle  $PAB$ ,

$$y'^2 = z^2 + y^2. \quad (2)$$

Substitute the value of  $y'^2$  from (2) in (1). Then

$$x^2 + 4z^2 + 4y^2 - 12x = 0,$$

which is the required equation.

EXAMPLE.—Rotate the line,  $2x + 3z = 12$ ,  $y = 0$ , about the  $Z$ -axis to form a cone. Determine the equation of the cone.

Pass a plane through  $OZ$  and  $P$ , and another plane through  $P$  perpendicular to the axis  $OZ$ .

The equation of the line in the  $ZOX'$ -plane is

$$2x' + 3z = 12. \quad (1)$$

From the right triangle  $ABP$ ,

$$x' = \sqrt{x^2 + y^2}. \quad (2)$$

Substitute (2) in (1); then

$$2\sqrt{x^2 + y^2} + 3z = 12,$$

or

$$\frac{12 - 3z}{2} = \sqrt{x^2 + y^2}.$$

Then

$$x^2 + y^2 = \frac{(12 - 3z)^2}{4}.$$

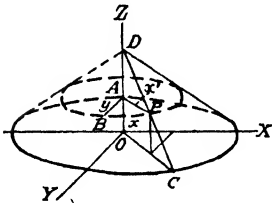

FIG. 484.

From the first example, we see that the equation of a surface of revolution was obtained by the substitution of

$$\sqrt{y^2 + z^2} \text{ for } y,$$

and in the second case by the substitution of

$$\sqrt{x^2 + y^2} \text{ for } x.$$

In general, in the equation of the curve, find the square root of the squares of the two variables different from the variable measured on the axis of rotation, and substitute for the one of the two variables which appears in the equation of the curve.

For equations in  $x$  and  $y$  rotated about the  $X$ -axis, substitute

$$\sqrt{y^2 + z^2} \text{ for } y,$$

since  $y$  and  $z$  are the two variables different from  $x$ ; hence,  $\sqrt{y^2 + z^2}$ , and since  $y$  appears in the equation, it is the variable for which the radical is substituted.

To put in different form:

If  $f(x, y) = 0$  is the equation in the  $XY$ -plane and the  $X$ -axis is the axis of revolution, the equation of the surface of revolution is

$$f(x, \sqrt{y^2 + z^2}) = 0.$$

If  $f(x, y) = 0$  is rotated about the  $Y$ -axis, the equation of the surface of revolution is

$$f(\sqrt{x^2 + z^2}, y) = 0.$$

If the curve  $f(y, z) = 0$  is rotated about the  $Z$ -axis, the equation of the surface of revolution is

$$f(\sqrt{x^2 + y^2}, z) = 0.$$

**850. Equation of Cone.**—Surface of cone generated by rotating the right line,  $z = mx + c$ , about the  $Z$ -axis.

Substitute  $\sqrt{x^2 + y^2}$  for  $x$ .

Then

$$z = m\sqrt{x^2 + y^2} + c, \text{ or } \sqrt{x^2 + y^2} = \frac{z - c}{m},$$

whence

$$[429] \quad x^2 + y^2 = \frac{(z - c)^2}{m^2}.$$

Likewise, with the right line,  $y = mx + k$ , about the  $X$ -axis, substitute  $\sqrt{y^2 + z^2}$  for  $y$ ; then

$$\sqrt{y^2 + z^2} = mx + k, \text{ or } y^2 + z^2 = (mx + k)^2.$$

**851. Oblate Spheroid.**—The ellipse,

$$\frac{x^2}{a^2} + \frac{z^2}{b^2} = 1,$$

rotated about its minor axis is an oblate spheroid. We, therefore, rotate about the  $Z$ -axis.

Substitute  $\sqrt{x^2 + y^2}$  for  $x$ ; then

$$\frac{x^2 + y^2}{a^2} + \frac{z^2}{b^2} = 1,$$

or

$$[430] \quad \frac{x^2}{a^2} + \frac{y^2}{a^2} + \frac{z^2}{b^2} = 1.$$

**852. Prolate Spheroid.**—The ellipse,

$$\frac{x^2}{a^2} + \frac{z^2}{b^2} = 1,$$

rotated about its major axis ( $X$ -axis) is a prolate spheroid.

Substitute  $\sqrt{y^2 + z^2}$  for  $z$ .

Then

$$[431] \quad \frac{x^2}{a^2} + \frac{y^2}{b^2} + \frac{z^2}{b^2} = 1.$$

**853. Paraboloid of revolution** is the surface generated by rotating the parabola,

$$x^2 = 2pz,$$

about its axis, or the  $Z$ -axis.

Substitute  $\sqrt{x^2 + y^2}$  for  $x$  and the equation becomes

$$[432] \quad x^2 + y^2 = 2pz,$$

which is the required equation.

**854. The hyperboloid of one nappe** is the surface generated by rotating the hyperbola,

$$\frac{x^2}{a^2} - \frac{z^2}{b^2} = 1,$$

about its conjugate axis (the  $Z$ -axis).

Substitute  $\sqrt{x^2 + y^2}$  for  $x$ .

Then

$$[433] \quad \frac{x^2}{a^2} + \frac{y^2}{a^2} - \frac{z^2}{b^2} = 1$$

is the desired equation.

**855. The hyperboloid of two nappes** is the surface generated by the rotation of the hyperbola,

$$\frac{x^2}{a^2} - \frac{z^2}{b^2} = 1,$$

about its transverse axis (the  $X$ -axis).

Substitute  $\sqrt{y^2 + z^2}$  for  $z$ .

Then

$$[434] \quad \frac{x^2}{a^2} - \frac{y^2}{b^2} - \frac{z^2}{b^2} = 1$$

is the required equation.

## CHAPTER XXXIX

### LINEAR EQUATIONS IN THREE VARIABLES

#### LINEAR EQUATIONS

**856. The Plane.**—The normal form of the equation of the plane is the most convenient and will be considered first.

Consider any plane as  $ABC$ .

Draw  $ON$  perpendicular to the plane  $ABC$  and positive.

Let  $OD = p$ , the distance from the origin to the plane, considering  $D$  as the piercing point of  $ON$  in the plane.

Let  $\alpha, \beta, \gamma$  be the direction angles of  $ON$ .

Let  $P(x, y, z)$  be any point on the plane  $ABC$ , and draw the coordinates of  $P$ . Then

$$OE = x, \quad EF = y, \quad FP = z.$$

Project  $OE + EF + FP$  and  $OP$  on  $ON$ . Then

Projection of  $OE +$  Projection of  $EF +$  Projection of  $FP =$   
Projection of  $OP$ .

Then

$$x \cos \alpha + y \cos \beta + z \cos \gamma = p,$$

or

$$[435] \quad x \cos \alpha + y \cos \beta + z \cos \gamma - p = 0.$$

This is the normal form of the equation of a plane where  $p$  is the perpendicular distance from the origin to the plane and  $\alpha, \beta, \gamma$  are the direction angles of the perpendicular.

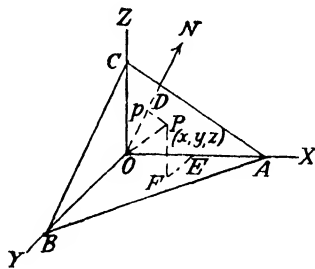

FIG. 485.

**857. General Equation of First Degree.**

$$[436] \quad Ax + By + Cz + D = 0$$

is the equation of a plane for it may be reduced to the normal form.

Multiply the equation by a constant  $k$ , whose value is to be determined, giving

$$kAx + kBy + kCz + kD = 0. \quad (1)$$

Comparing with the normal form,

$$x \cos \alpha + y \cos \beta + z \cos \gamma - p = 0, \text{ [435]}$$

then

$$kA = \cos \alpha, kB = \cos \beta, kC = \cos \gamma, \quad (2)$$

$$kD = -p. \quad (3)$$

Squaring equations (2) and adding,

$$k^2(A^2 + B^2 + C^2) = \cos^2 \alpha + \cos^2 \beta + \cos^2 \gamma = 1 \text{ (Art. 837).}$$

Therefore,

$$k = \frac{1}{\pm \sqrt{A^2 + B^2 + C^2}}.$$

Substituting in (1),

$$[437] \frac{A}{\sqrt{A^2 + B^2 + C^2}}x + \frac{B}{\sqrt{A^2 + B^2 + C^2}}y + \frac{C}{\sqrt{A^2 + B^2 + C^2}}z = \frac{-D}{\sqrt{A^2 + B^2 + C^2}}.$$

It will be noted that equation [437] is in the normal form with

$$\cos \alpha = \frac{A}{\pm \sqrt{A^2 + B^2 + C^2}}, \cos \beta = \frac{B}{\pm \sqrt{A^2 + B^2 + C^2}},$$

[438]

$$\cos \gamma = \frac{C}{\pm \sqrt{A^2 + B^2 + C^2}}, p = \frac{-D}{\pm \sqrt{A^2 + B^2 + C^2}}.$$

From the above it is evident that the sign of the radical must be taken opposite to that of  $D$  in order that  $p$  may be positive.

Therefore, to put the general equation into the normal form, divide the equation by

$$\pm \sqrt{A^2 + B^2 + C^2},$$

with the sign of the radical opposite to that of  $D$ .

The coefficients of  $x$ ,  $y$ , and  $z$  in the equation of a plane are proportional to the direction cosines of any line perpendicular to the planes. Then, two planes, as

$Ax + By + Cz + D = 0$  and  $A'x + B'y + C'z + D' = 0$ , are parallel if

$$\frac{A}{A'} = \frac{B}{B'} = \frac{C}{C'}$$

and perpendicular if

$$AA' + BB' + CC' = 0.$$

The angle between two planes not parallel is found from

$$[439] \cos \theta = \frac{AA' + BB' + CC'}{\sqrt{A^2 + B^2 + C^2} \cdot \sqrt{A'^2 + B'^2 + C'^2}}.$$



**858.** An equation of the form:

$Ax + By + D = 0$  represents a plane perpendicular to the  $XY$ -plane.

$By + Cz + D = 0$  represents a plane perpendicular to the  $YZ$ -plane.

$Ax + Cz + D = 0$  represents a plane perpendicular to the  $XZ$ -plane.

An equation of the form:

$Ax + D = 0$  represents a plane perpendicular to the  $X$ -axis.

$By + D = 0$  represents a plane perpendicular to the  $Y$ -axis.

$Cz + D = 0$  represents a plane perpendicular to the  $Z$ -axis.

If, in the equation,  $D = 0$ , the plane evidently passes through the origin.

EXAMPLE.—Find the equation of the plane which passes through the point  $P(2, 3, 4)$  and is parallel to the plane represented by

$$24x - 15y + 27z - 80 = 0.$$

Assume the required equation to be of the form,

$$Ax + By + Cz + D = 0. \tag{1}$$

Since the required plane is parallel to the given plane, the ratios of their coefficients are equal. Then

$$\frac{A}{24} = \frac{B}{-15} = \frac{C}{27}. \tag{2}$$

Since  $P$  is in the required plane, we can substitute the coordinates of  $P$  in (1).

$$2A + 3B + 4C + D = 0. \tag{3}$$

Solving the simultaneous equations (2)

$$A = \frac{2}{3}C, B = -\frac{4}{3}C. \tag{4}$$

Substituting in (3),

$$\frac{4}{3}C - \frac{16}{3}C + 4C + D = 0.$$

Then

$$D = -\frac{12}{3}C. \tag{5}$$

Substituting (4) and (5) in (1),

$$\frac{2}{3}Cx - \frac{4}{3}Cy + Cz - \frac{12}{3}C = 0.$$

Dividing by  $C$  and multiplying by 9,

$$8x - 5y + 9z - 37 = 0,$$

which is the required equation.

See also Art. 862 for a better solution of this problem.

**859. Equation of Plane in Terms of Intercepts.**—If  $a$ ,  $b$ , and  $c$  are the intercepts on the  $X$ -,  $Y$ -, and  $Z$ -axes, and

$$Ax + By + Cz + D = 0 \text{ [436]}$$

is the equation of the plane, then since the coordinate points  $(a, 0, 0)$ ,  $(0, b, 0)$ , and  $(0, 0, c)$  must satisfy the equation of the plane, then by substituting,

$$Aa + D = 0, Bb + D = 0, Cc + D = 0,$$

or

$$A = -\frac{D}{a}, B = -\frac{D}{b}, C = -\frac{D}{c}.$$

Substituting in the equation of the plane,

$$-\frac{D}{a}x - \frac{D}{b}y - \frac{D}{c}z + D = 0.$$

Dividing by  $-D$ ,

[440] 
$$\frac{x}{a} + \frac{y}{b} + \frac{z}{c} = 1,$$

which is the intercept form of the equation of the plane.

**860. Perpendicular Distance from a Point to a Plane.**—First, put the equation of the plane into the normal form,

$$x \cos \alpha + y \cos \beta + z \cos \gamma - p = 0 \text{ [435].}$$

Let the coordinates of the point  $P_o$  be  $(x_o, y_o, z_o)$  and  $d$  the required distance.

Project  $OE$ ,  $EF$ , and  $FP_o$  on  $ON$ , or

$$OE = x_o \cos \alpha.$$

$$EF = y_o \cos \beta.$$

$$FP_o = z_o \cos \gamma.$$

Then

$$p + d = x_o \cos \alpha + y_o \cos \beta + z_o \cos \gamma,$$

or

[441] 
$$d = x_o \cos \alpha + y_o \cos \beta + z_o \cos \gamma - p.$$

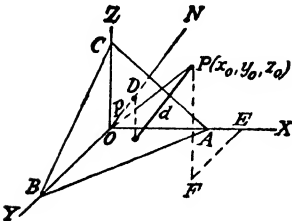

FIG. 486.

The required distance is given when the coordinates of the given point  $P_o(x_o, y_o, z_o)$  are substituted in the equation of the given plane in the normal form.

**EXAMPLE.**—What is the perpendicular distance from the point  $(-1, 2, 3)$  to the plane,  $2x + y - 2z + 8 = 0$ ?

$$A = 2, B = 1, C = -2, D = 8.$$

From [438], Art. 857,

$$\cos \alpha = \frac{A}{\pm \sqrt{A^2 + B^2 + C^2}} = \frac{2}{\pm \sqrt{4 + 1 + 4}} = \frac{2}{-3} = -\frac{2}{3}.$$

The sign of  $D$  is positive; therefore, the sign of the radical should be taken negative in order to make  $p$  positive.

$$\begin{aligned} \cos \beta &= \frac{B}{-\sqrt{A^2 + B^2 + C^2}} = \frac{1}{-3} = -\frac{1}{3}. \\ \cos \gamma &= \frac{C}{-\sqrt{A^2 + B^2 + C^2}} = \frac{-2}{-3} = \frac{2}{3}. \\ p &= \frac{-D}{-\sqrt{A^2 + B^2 + C^2}} = \frac{-8}{-3} = \frac{8}{3}. \\ d &= (-1)\left(-\frac{2}{3}\right) + (2)\left(-\frac{1}{3}\right) + (3)\left(\frac{2}{3}\right) - \frac{8}{3} \quad [441] \\ &= +\frac{2}{3} - \frac{2}{3} + \frac{6}{3} - \frac{8}{3} = -\frac{2}{3}. \end{aligned}$$

**861. System of Planes.**—The equation of a plane which satisfies two of the three conditions necessary to determine a plane usually contains an arbitrary constant. Such an equation, therefore, represents a system of planes. Two such systems of planes are especially important.

**862. System of Parallel Planes.**—The equation of a system of planes parallel to the given plane,

$$Ax + By + Cz + D = 0,$$

is

[442] 
$$Ax + By + Cz + k = 0,$$

where  $k$  is an arbitrary constant.

**EXAMPLE.**—Find the equation of the plane which passes through the point  $P(3, 2, -1)$  and is parallel to the plane,

$$7x - y - z - 14 = 0.$$

The equation of the parallel plane is then

$$7x - y - z + k = 0.$$

Substitute the coordinates of  $P(3, 2, -1)$  in the above equation since the point lies on the plane. Then

$$21 - 2 + 1 + k = 0.$$

$$\therefore k = -20.$$

Substitute this value of  $k$  in the equation, which gives

$$7x - y - z - 20 = 0$$

as the equation of the required plane.

**863. System of Planes Passing through the Line of Intersection of Two Planes.**—If the two planes are

$$A_1x + B_1y + C_1z + D_1 = 0 \text{ and}$$

$$A_2x + B_2y + C_2z + D_2 = 0,$$

then the system of planes required is represented by

[443]  $A_1x + B_1y + C_1z + D_1 + k(A_2x + B_2y + C_2z + D_2) = 0$ ,  
where  $k$  is an arbitrary constant.

The reason for this is that the coordinates of any point on the line of intersection of the given planes must satisfy both equations, and they will, therefore, satisfy the equation of the system.

EXAMPLE.—Find the equation which passes through the intersection of the planes,

$$\begin{aligned} 2x + y - 4 &= 0 \text{ and} \\ y + 2z &= 0, \end{aligned}$$

and is perpendicular to the plane,

$$3x + 2y - 3z = 6.$$

The equation of the system of planes passing through the line of intersection of the given planes is

$$2x + y - 4 + k(y + 2z) = 0,$$

which reduces to

$$2x + (k + 1)y + 2kz - 4 = 0.$$

In order to be perpendicular to  $3x + 2y - 3z = 6$ , the relation of the coefficients must be

$$\begin{aligned} A_1A_2 + B_1B_2 + C_1C_2 &= 0. \\ A_1 &= 2, B_1 = k + 1, C_1 = 2k. \\ A_2 &= 3, B_2 = 2, C_2 = -3. \end{aligned}$$

Substituting,

$$\begin{aligned} 2 \cdot 3 + (k + 1) \cdot 2 + 2k \cdot (-3) &= 0. \\ 6 + 2 + 2k - 6k &= 0. \\ -4k &= -8. \\ k &= 2. \end{aligned}$$

Substituting this value of  $k$  in the equation of the system,

$$2x + y - 4 + 2(y + 2z) = 0,$$

which reduces to

$$2x + 3y + 4z - 4 = 0$$

and is the equation of the required plane.

**864. Set of All Planes Passing through a Point  $P_0(x_0, y_0, z_0)$ .—**  
Suppose that the plane represented by

$$Ax + By + Cz + D = 0 \tag{1}$$

passes through the point  $P_0(x_0, y_0, z_0)$ . Then, obviously, the coordinates of the point must satisfy the equation of the plane, or

$$Ax_0 + By_0 + Cz_0 + D = 0. \tag{2}$$

Subtract (2) from (1). Then

[444]  $A(x - x_0) + B(y - y_0) + C(z - z_0) = 0.$

**EXAMPLE.**—Find the equation of a plane passing through the point  $(1, -2, 1)$  and parallel to the plane,

$$y - 3x + 4z - 5 = 0.$$

The equation of the plane, since it is parallel to the given plane, is

$$y - 3x + 4z + k = 0,$$

but from [444] above,

$$A(x - 1) + B(y + 2) + C(z - 1) = 0.$$

Developing,

$$Ax + By + Cz - A + 2B - C = 0.$$

Comparing the two equations,

$$A = -3, B = 1, C = 4, k = -A + 2B - C = 3 + 2 - 4 = 1.$$

The required equation is, therefore,

$$3x - y - 4z - 1 = 0.$$

See also Arts. 857 and 862.

**865. Plane through Three Points.**—If the plane,

$$Ax + By + Cz + D = 0,$$

is to pass through three points  $P_1(x_1, y_1, z_1)$ ,  $P_2(x_2, y_2, z_2)$ , and  $P_3(x_3, y_3, z_3)$ , the three conditions,

$$Ax_1 + By_1 + Cz_1 + D = 0,$$

$$Ax_2 + By_2 + Cz_2 + D = 0,$$

$$Ax_3 + By_3 + Cz_3 + D = 0,$$

must be satisfied.

From these four equations solve for the ratios of the coefficients  $A, B, C$ , and  $D$ . The best procedure is to solve for  $A, B$ , and  $C$  in the last three equations in terms of  $D$ , and then substitute their values in the first equation,

$$Ax + By + Cz + D = 0,$$

**EXAMPLE.**—Find the equation of the plane which passes through the points  $(2, 3, 0)$ ,  $(-2, -3, 4)$ , and  $(0, 6, 0)$ .

Substituting the given coordinate values in the formulae, then

$$2A + 3B + D = 0. \tag{1}$$

$$-2A - 3B + 4C + D = 0. \tag{2}$$

$$6B + D = 0. \tag{3}$$

$$\text{From (3), } B = -\frac{D}{6}. \tag{4}$$

Substituting three times (4) in (1),

$$2A - \frac{D}{2} + D = 0.$$

$$A = -\frac{D}{4}. \tag{5}$$

Substituting two times (5) and three times (4) in (2),

$$\frac{D}{2} + \frac{D}{2} + 4C + D = 0.$$

$$4C + 2D = 0.$$

$$C = -\frac{D}{2}. \quad (6)$$

Substituting (5), (4), and (6) in  $Ax + By + Cz + D = 0$ ,

$$-\frac{D}{4}x - \frac{D}{6}y - \frac{D}{2}z + D = 0.$$

Multiplying through by  $-\frac{12}{D}$ ,

$$3x + 2y + 6z - 12 = 0, \text{ which is the equation sought.}$$

**866. Bisecting Planes.**—To find the equations of the two planes that bisect the angles formed by two intersecting planes:

First, put the equations of the planes into the normal form and then, since any point in the bisecting planes is equidistant from the two given planes, or the distance from the point to the two planes is equal in absolute value,

$$[445] \frac{\frac{A_1}{\pm \sqrt{A_1^2 + B_1^2 + C_1^2}}x + \frac{B_1}{\pm \sqrt{A_1^2 + B_1^2 + C_1^2}}y + \frac{C_1}{\pm \sqrt{A_1^2 + B_1^2 + C_1^2}}z + \frac{D_1}{\pm \sqrt{A_1^2 + B_1^2 + C_1^2}}}{\frac{A_2}{\pm \sqrt{A_2^2 + B_2^2 + C_2^2}}x + \frac{B_2}{\pm \sqrt{A_2^2 + B_2^2 + C_2^2}}y + \frac{C_2}{\pm \sqrt{A_2^2 + B_2^2 + C_2^2}}z + \frac{D_2}{\pm \sqrt{A_2^2 + B_2^2 + C_2^2}}}$$

is the equation of the planes which bisect the angles formed by the intersecting planes,

$$A_1x + B_1y + C_1z + D_1 = 0 \text{ and}$$

$$A_2x + B_2y + C_2z + D_2 = 0.$$

**867. The Straight Line.**—The intersection of two planes is a straight line; hence, two simultaneous equations of first degree represent a straight line in space, as

$$A_1x + B_1y + C_1z + D_1 = 0 \text{ and}$$

$$A_2x + B_2y + C_2z + D_2 = 0.$$

A more convenient way to represent lines is to reduce the above equations to a straight-line equation in two variables only. This is done by eliminating one variable from the equations. In

this case, the equation represents the projection of the line upon one of the coordinate planes and is a plane geometry equation in this coordinate plane.

To project the line on the  $XY$ -plane, eliminate  $z$ .

In the above equations,

$$z = \frac{-A_1x - B_1y - D_1}{C_1} = \frac{-A_2x - B_2y - D_2}{C_2}.$$

Then

$$C_2(A_1x + B_1y + D_1) = C_1(A_2x + B_2y + D_2).$$

Collecting,

[446]  $(A_1C_2 - A_2C_1)x + (B_1C_2 - B_2C_1)y + (C_2D_1 - C_1D_2) = 0.$

If put into the slope form, the projection on the  $XY$ -plane is represented by

[447]  $y = \frac{A_2C_1 - A_1C_2}{B_1C_2 - B_2C_1}x + \frac{C_1D_2 - C_2D_1}{B_1C_2 - B_2C_1}.$

The projection on the  $XZ$ -plane is represented by

[448]  $x = \frac{B_1C_2 - B_2C_1}{A_1B_2 - A_2B_1}z + \frac{B_1D_2 - B_2D_1}{A_1B_2 - A_2B_1}.$

The projection on the  $YZ$ -plane is represented by

[449]  $y = \frac{A_1C_2 - A_2C_1}{A_2B_1 - A_1B_2}z + \frac{A_1D_2 - A_2D_1}{A_2B_1 - A_1B_2}.$

EXAMPLE.—Determine the equations for the projection on the coordinate planes of the straight line represented by

$$3x + 2y + z - 5 = 0.$$

$$x + 2y - 2z - 3 = 0.$$

$$A_1 = 3, B_1 = 2, C_1 = 1, D_1 = -5.$$

$$A_2 = 1, B_2 = 2, C_2 = -2, D_2 = -3.$$

$$y = \frac{1 \cdot 1 - 3 \cdot (-2)}{2 \cdot (-2) - 2 \cdot 1}x + \frac{1 \cdot (-3) - (-2)(-5)}{2 \cdot (-2) - 2 \cdot 1}.$$

$$-y = \frac{1}{2}x - \frac{13}{2}, \text{ or}$$

$$7x + 6y - 13 = 0,$$

which is the equation of the projection of the given line on the  $XY$ -plane.

Likewise,

$$x = -\frac{1}{2}z + 1, \text{ or } 2x + 3z - 2 = 0,$$

is the equation of the projection of the given line on the  $XZ$ -plane, and

$$y = \frac{1}{2}z + 1, \text{ or } 4y - 7z - 4 = 0,$$

is the equation of the projection of the line on the  $YZ$ -plane.

In Fig. 487 is shown the location of the line and its projections on the coordinate planes.

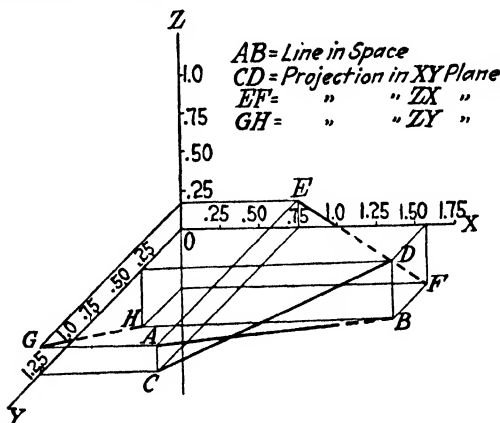

FIG. 487.

In the graph, note that the projection lines  $AC$  and  $DB$  for the projection of  $AB$  on the  $XY$ -plane are parallel to the  $Z$ -axis, and that  $AE$  and  $BF$  for the projection of  $AB$  on the  $XZ$ -plane are parallel to the  $Y$ -axis. Also,  $GA$  and  $HB$  for the projection of  $AB$  on the  $YZ$ -plane are parallel to the  $X$ -axis.

**868. Standard Equations of the Straight Line through a Given Point  $P_0(x_0, y_0, z_0)$  and with Direction Angles  $\alpha$ ,  $\beta$ , and  $\gamma$ .**

Let  $P(x, y, z)$  be any other point on the line at a distance  $d$  from  $P_0$ .

From the distance formula (Art. 837) [425],

$$\cos \alpha = \frac{x - x_0}{d}, \quad \cos \beta = \frac{y - y_0}{d}, \quad \cos \gamma = \frac{z - z_0}{d},$$

from which

$$[450] \quad \frac{x - x_1}{\cos \alpha} = \frac{y - y_1}{\cos \beta} = \frac{z - z_1}{\cos \gamma},$$

which are the symmetrical or standard equations of the straight line.

**869. Straight Line through Two Given Points.**—Let  $P_1(x_1, y_1, z_1)$  and  $P_2(x_2, y_2, z_2)$  be the two given points.

From the preceding article,

$$\frac{x - x_1}{\cos \alpha} = \frac{y - y_1}{\cos \beta} = \frac{z - z_1}{\cos \gamma}, \quad [450] \quad (1)$$



and also

$$\frac{x_1 - x_2}{\cos \alpha} = \frac{y_1 - y_2}{\cos \beta} = \frac{z_1 - z_2}{\cos \gamma}. \tag{2}$$

Divide (1) by (2) to eliminate the unknown direction cosines. Then either

$$\frac{x - x_1}{x_2 - x_1} = \frac{y - y_1}{y_2 - y_1} = \frac{z - z_1}{z_2 - z_1}$$

or [451]

$$\frac{x - x_1}{x_1 - x_2} = \frac{y - y_1}{y_1 - y_2} = \frac{z - z_1}{z_1 - z_2}$$

**870. Line Parallel to a Plane.**—A line whose direction angles are  $\alpha$ ,  $\beta$ , and  $\gamma$  is parallel to the plane,

$$Ax + By + Cz + D = 0,$$

when and only when

$$A \cos \alpha + B \cos \beta + C \cos \gamma = 0.$$

**871. Line Perpendicular to a Plane.**—A line whose direction angles are  $\alpha$ ,  $\beta$ , and  $\gamma$  is perpendicular to the plane,

$$Ax + By + Cz + D = 0,$$

when and only when

$$\frac{A}{\cos \alpha} = \frac{B}{\cos \beta} = \frac{C}{\cos \gamma}.$$

## CHAPTER XL

### SECOND-DEGREE EQUATIONS IN THREE DIMENSIONS

#### 872. Equations of Second Degree.

[452]  $Ax^2 + By^2 + Cz^2 + Dxy + Eyz + Fxz + Gx + Hy + Kz + L = 0.$

Equations of this type are called *quadric surfaces* or *conicoids* because every section of a quadric surface by a plane is a conic.

There are five non-degenerate types, namely,

Ellipsoid.

Hyperboloid of one sheet.

Hyperboloid of two sheets.

Elliptic paraboloid.

Hyperbolic paraboloid.

The degenerate types are cones, cylinders, planes, lines, and points.

**873. Ellipsoid.**—The simplest standard equation is

453] 
$$\frac{x^2}{a^2} + \frac{y^2}{b^2} + \frac{z^2}{c^2} = 1.$$

This surface can be conceived as generated by a variable ellipse moving parallel to the  $XY$ -plane with its center always on the  $Z$ -axis, the end points of the axis parallel to the  $X$ -axis following the ellipse,

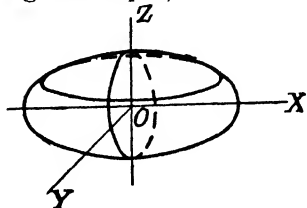

FIG. 488.

$$\frac{x^2}{a^2} + \frac{z^2}{c^2} = 1,$$
 and the end points of the axis parallel to the  $Y$ -axis following the ellipse,

$$\frac{y^2}{b^2} + \frac{z^2}{c^2} = 1.$$

The intercepts on the coordinate axes are

$$X = \pm a, \quad Y = \pm b, \quad Z = \pm c.$$

Its traces on the coordinate planes are:

In the  $XY$ -plane, the ellipse,  $\frac{x^2}{a^2} + \frac{y^2}{b^2} = 1.$

In the  $XZ$ -plane, the ellipse,  $\frac{x^2}{a^2} + \frac{z^2}{c^2} = 1$ .

In the  $YZ$ -plane, the ellipse,  $\frac{y^2}{b^2} + \frac{z^2}{c^2} = 1$ .

The equation for the intersection of the ellipsoid,

$$\frac{x^2}{a^2} + \frac{y^2}{b^2} + \frac{z^2}{c^2} = 1,$$

and the plane,  $z = k$ , parallel to the  $XY$ -plane is formed by substituting  $z = k$  in the equation of the ellipsoid, and is

$$\frac{x^2}{a^2} + \frac{y^2}{b^2} = 1 - \frac{k^2}{c^2},$$

or

$$\frac{x^2}{\frac{a^2}{c^2}(c^2 - k^2)} + \frac{y^2}{\frac{b^2}{c^2}(c^2 - k^2)} = 1.$$

This ellipse, it might be interpreted, is the ellipse which generates the ellipsoid as  $k$  takes on all values between  $+c$  and  $-c$ .

Its semimajor axis is equal to

$$\frac{a}{c} \sqrt{c^2 - k^2},$$

and its semiminor axis is equal to

$$\frac{b}{c} \sqrt{c^2 - k^2}.$$

It is assumed that  $a > b$ . If, however, the axes are interchanged, then  $a < b$ .

Another form of the equation of the ellipsoid is

$$\frac{\frac{y^2}{b^2(a^2 - x^2)}}{a^2} + \frac{\frac{z^2}{c^2(a^2 - x^2)}}{a^2} = 1.$$

From this form, it is readily seen how the major and minor axes vary, since a variable appears in the denominator of both  $y^2$  and  $z^2$ .

**874. The Hyperboloid of One Sheet.**—The standard equation is

[454] 
$$\frac{x^2}{a^2} + \frac{y^2}{b^2} - \frac{z^2}{c^2} = 1.$$

This surface can be conceived as being generated by a variable ellipse moving parallel to the  $XY$ -plane with its center on the  $Z$ -

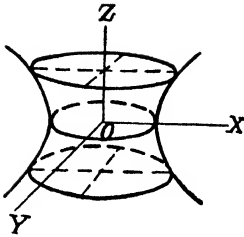

FIG. 489.

axis, the end points of the axis parallel to the X-axis following the hyperbola,

$$\frac{x^2}{a^2} - \frac{z^2}{c^2} = 1,$$

and the end points of the axis parallel to the Y-axis following the hyperbola,

$$\frac{y^2}{b^2} - \frac{z^2}{c^2} = 1.$$

Its intercepts on the axes are

$$X = \pm a, \quad Y = \pm b.$$

Its traces on the coordinate planes are:

In the  $XY$ -plane, the ellipse,  $\frac{x^2}{a^2} + \frac{y^2}{b^2} = 1$ .

In the  $XZ$ -plane, the hyperbola,  $\frac{x^2}{a^2} - \frac{z^2}{c^2} = 1$ .

In the  $YZ$ -plane, the hyperbola,  $\frac{y^2}{b^2} - \frac{z^2}{c^2} = 1$ .

This surface has the property that two straight lines may be drawn through any point on the surface which will lie wholly in the surface.

The equation is also written in the forms,

$$\frac{x^2}{a^2(c^2 + z^2)} + \frac{y^2}{b^2(c^2 + z^2)} = 1,$$

and

$$\frac{y^2}{b^2(a^2 - x^2)} - \frac{z^2}{c^2(a^2 - x^2)} = 1.$$

The intersection of the hyperboloid of one sheet,

$$\frac{x^2}{a^2} + \frac{y^2}{b^2} - \frac{z^2}{c^2} = 1,$$

and the plane,  $z = k$ , parallel to the  $XY$ -plane is formed by substituting  $z = k$  in the above equation which becomes

$$\frac{x^2}{a^2} + \frac{y^2}{b^2} = 1 + \frac{k^2}{c^2},$$

or

$$\frac{x^2}{\frac{a^2}{c^2}(c^2 + k^2)} + \frac{y^2}{\frac{b^2}{c^2}(c^2 + k^2)} = 1.$$

This equation may be considered as the equation of the generating ellipse as  $k$  takes on different values or as the intersecting plane is moved parallel to the  $XY$ -plane.

**875. The Hyperboloid of Two Sheets.**—The standard equation is

$$[455] \quad \frac{x^2}{a^2} - \frac{y^2}{b^2} - \frac{z^2}{c^2} = 1.$$

For convenience in considering sections, we may consider the hyperboloid of two sheets to be a surface generated by a varying ellipse moving parallel to the  $YZ$ -plane with its center in the  $X$ -axis.

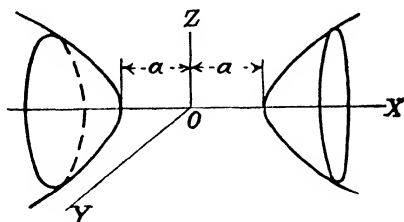

FIG. 490.

Its only intercepts are at  $x = \pm a$ .

The traces on the coordinate planes are represented by:

In the  $XY$ -plane, the hyperbola,  $\frac{x^2}{a^2} - \frac{y^2}{b^2} = 1$ .

In the  $XZ$ -plane, the hyperbola,  $\frac{x^2}{a^2} - \frac{z^2}{c^2} = 1$ .

No trace in the  $YZ$ -plane.

The intersection of this surface and the plane,  $x = k$ , parallel to the  $YZ$ -plane is represented by the equation formed when  $x$  in  $\frac{x^2}{a^2} - \frac{y^2}{b^2} - \frac{z^2}{c^2} = 1$  is replaced by  $k$ . The equation then becomes

$$\frac{y^2}{b^2} + \frac{z^2}{c^2} = \frac{k^2}{a^2} - 1,$$

or

$$\frac{y^2}{\frac{b^2}{a^2}(k^2 - a^2)} + \frac{z^2}{\frac{c^2}{a^2}(k^2 - a^2)} = 1.$$

This equation may be interpreted to be the equation of the generating ellipse as  $k$  varies. The ellipse is imaginary if

$$-a < k < a,$$

and, therefore, there is no part of the surface between  $x = -a$  and  $x = a$ .

**876. Elliptic Paraboloid.**—The standard equation is

[456] 
$$\frac{x^2}{a^2} + \frac{y^2}{b^2} = z.$$

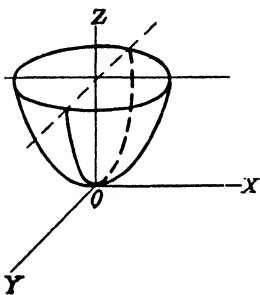

FIG. 491.

This surface can be conceived to be generated by a variable ellipse moving parallel to the  $XY$ -plane, whose center is on the  $Z$ -axis, and with the end points of the axis parallel to the  $X$ -axis following the parabola,  $x^2 = a^2z$ , and with the end points of the axis parallel to the  $Y$ -axis following the parabola,  $y^2 = b^2z$ .

Its intercepts are

$$X = 0, Y = 0, Z = 0.$$

Its traces on the coordinate planes are:

In the  $XY$ -plane, the point ellipse,

$$\frac{x^2}{a^2} + \frac{y^2}{b^2} = 0.$$

In the  $XZ$ -plane, the parabola,

$$x^2 = a^2z.$$

In the  $YZ$ -plane, the parabola,

$$y^2 = b^2z.$$

The intersection of the elliptic paraboloid,

$$\frac{x^2}{a^2} + \frac{y^2}{b^2} = z,$$

and the plane,  $z = k$ , parallel to the  $XY$ -plane is represented by the equation,

$$\frac{x^2}{a^2} + \frac{y^2}{b^2} = k,$$

or

$$\frac{x^2}{a^2k} + \frac{y^2}{b^2k} = 1.$$

These equations may be considered as the equations of the variable ellipse which generates the elliptic paraboloid as  $k$  varies from zero to infinity.

**877. The Hyperbolic Paraboloid.**—The standard equation is

[457] 
$$\frac{x^2}{a^2} - \frac{y^2}{b^2} = z.$$

The generating curve in this case will be taken as the parabola in the plane,  $x = k$ , parallel to the  $YZ$ -plane. Then

$$\frac{k^2}{a^2} - \frac{y^2}{b^2} = z.$$

$$y^2 = -b^2\left(z - \frac{k^2}{a^2}\right),$$

which is the equation of the generating parabola with vertex at

$$\left(k, 0, \frac{k^2}{a^2}\right),$$

and following the parabola,  $x^2 = a^2z$ , in the  $XZ$ -plane. This parabola has its vertex pointing downward.

Sections parallel to the  $YZ$ -plane are parabolas with vertices pointing upward, and sections parallel to the  $XY$ -plane are hyperbolas.

This surface also has the property that a straight line lying wholly in the surface may be drawn through any point on the surface.

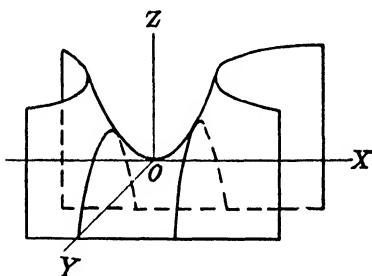

FIG. 492.

**878. The Cone.**—The standard equation is

[458] 
$$\frac{x^2}{a^2} + \frac{y^2}{b^2} - \frac{z^2}{c^2} = 0.$$

The surface of a cone can be conceived as being generated by a variable ellipse moving parallel to the  $XY$ -plane with end points of its major axis following the lines,

$$\frac{x^2}{a^2} - \frac{z^2}{c^2} = 0.$$

Its intercepts are  $x = 0, y = 0, z = 0$ .

Its traces on the coordinate planes are:

In the  $XY$ -plane, the point  $\frac{x^2}{a^2} + \frac{y^2}{b^2} = 0$ .

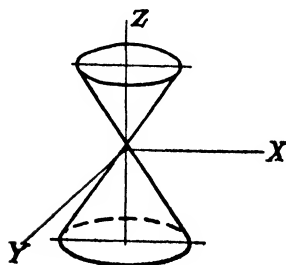

FIG. 493.

In the  $XZ$ -plane, the two lines  $\frac{x^2}{a^2} - \frac{z^2}{c^2} = 0$ .

In the  $YZ$ -plane, the two lines  $\frac{y^2}{b^2} - \frac{z^2}{c^2} = 0$ .

An examination of the equations of the cone and the elliptic hyperboloid,

$$\frac{x^2}{a^2} + \frac{y^2}{b^2} - \frac{z^2}{c^2} = 0,$$

$$\frac{x^2}{a^2} + \frac{y^2}{b^2} - \frac{z^2}{c^2} = 1,$$

shows a difference in the constant term only. The surfaces have no point in common. If  $y$  and  $z$  in the two equations are increased indefinitely, the corresponding values of  $x$  from the two equations approach each other. The hyperboloid and the cone are said to be asymptotic to each other and bear the same relation to each other as the plane hyperbola and its asymptotes.

**879. Cylinders.**—In Art. 843, it was shown that an equation in two variables represents a cylindrical surface. The cylinder whose elements intersect a given curve and are parallel to one of the coordinate axes is called a *projecting cylinder*. These projecting cylinders may be found by eliminating the third variable from the equation of the curve.

Any two of these equations of projecting cylinders may be conveniently used as the equation of the curve. The original curve can then be constructed by using the curve of intersection of the two cylinders.

**EXAMPLE.**—Construct the curve of intersection of the two cylinders,

$$x^2 + y^2 = 2y \quad (1)$$

$$y^2 + z^2 - 8z + 7 = 0. \quad (2)$$

Draw the trace of (1) in the  $XY$ -plane. The elements of the cylinder will be perpendicular to that plane.

Draw the trace of (2) in the  $YZ$ -plane. The elements of this cylinder will be perpendicular to that plane.

In order to make a good perspective of the cylinders, it is a good plan to make the  $Y$ -scale with a unit one-half as long as that used to construct the  $X$ - and  $Z$ -scales. Thus, if 1 inch = 1 is used as the  $X$ - and  $Z$ -scale, use  $\frac{1}{2}$  inch = 1 for the  $Y$ -scale.

In laying out an ellipse or a circle in perspective, draw the circumscribed square or rectangle of the circle or ellipse which



gives four points of contact with the circle or ellipse. These are the four center points of the four sides. This makes the ellipse or circle easier to plot.

The method is shown in Fig. 494.

Returning to the problem:

Consider a plane whose equation is  $y = k$ . It is parallel to the  $XZ$ -plane and to the elements of the projecting cylinders. It intersects the  $Y$ -axis at  $M$ , the trace in the  $XY$ -plane in the points  $A$  and  $B$ , and the trace in the  $YZ$ -plane in the points  $C$  and  $D$ . These points locate elements of the projecting cylinders. The points of intersection of these elements  $EF$  and  $GH$  of one cylinder and  $EG$  and  $FH$  of the other locate points on the curve of intersection. By taking several cutting planes or by giving  $k$  various values, the curve of intersection of the surfaces,  $x^2 + y^2 = 2y$  and  $y^2 + z^2 - 8z + 7 = 0$ , is constructed.



FIG. 494.

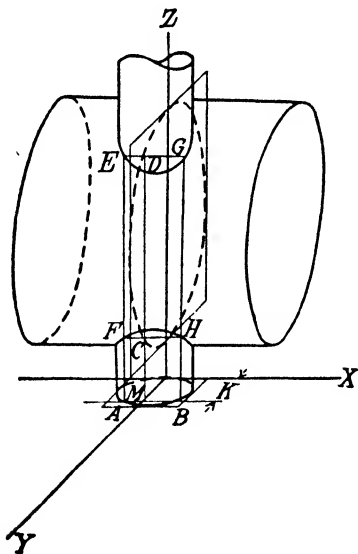

FIG. 495.

**880. Parametric Equations of a Curve in Space.**—If the coordinates in space are given as a function of a variable parameter, the curve is in parametric form, as

$$x = 4t^2, \quad y = 1 - 2t, \quad z = t^2 + 2.$$

The parametric equations of a helix furnish a good example and will be determined.

A point which moves on the surface of a right circular cylinder in such a manner that the distance that it moves parallel to the axis of the cylinder varies directly as the angle through which it rotates around the axis is called a *helix*.

Assume the equation of the circular cylinder,

$$x^2 + y^2 = r^2.$$

Let  $P_0$  be the starting point of the helix and let it be located on the  $X$ -axis.

Let  $P(x, y, z)$  be any point on the helix.

By the conditions stated,  $BP$  varies as  $k\theta$ , where  $k$  is a constant depending upon the pitch of the helix.

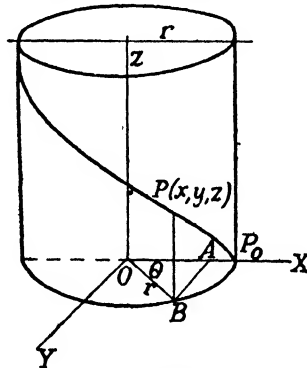

FIG. 496.

From the figure,

$$x = OA = OB \cos \theta = r \cos \theta \text{ and}$$

$$y = AB = OB \sin \theta = r \sin \theta.$$

Hence, the parametric equations of the helix are

$$x = r \cos \theta, \quad y = r \sin \theta, \quad z = k\theta.$$

## CHAPTER XLI ·

### DIFFERENTIAL CALCULUS

#### RATES OF CHANGE

**881.** Before undertaking the study of the calculus, it is advisable to review thoroughly the fundamental and important portions of algebra, trigonometry, and analytic geometry. A thorough knowledge of and a reasonable facility in the use of the methods of analysis of these subjects will materially aid in a proper understanding of the methods of the calculus.

It is quite essential that the relation which the function, or dependent variable, bears to the independent variable, or argument, be fully understood. In representing functions, we have used the ordinate as a measure of the value of the function for a certain value of the independent variable. The curve simply locates the end points of the ordinates with whose varying lengths we are concerned, offering a convenient method of indicating these lengths and of interpolating to find values of the function between those computed.

It is a matter of prime importance, in plotting functions, to use the proper variables for the function and for the independent variable. When two variable magnitudes vary in such a manner that the value of the first depends upon the value of the second, the first is a function of the second and is represented by the ordinate of a point whose abscissa represents the second, or independent variable, or, more simply, *the ordinates represent the values of the function while the corresponding abscissae represent the values of the independent variable.*

**882. Rate of Charge.**—One of the most fundamental problems treated in the calculus and one of the most important phases of physics is the determination of the rate of change of the variables, or the *amount* of change in the function per *unit* change in the value of the independent variable. If this rate of change

is a constant, the graph of the function is a straight line. That is, the ordinates increase (or decrease) by a certain amount for each unit of increase of the independent variable. In general, however, the rate of increase is not constant and it becomes necessary to consider, further, *the average rate of change and the instantaneous rate of change.*

Differential calculus is the study of these rates of change and it was through the investigation of problems of this sort that the calculus was developed.

**883. Average Rate of Change.**—The average rate of change or increase of a function in any interval is the amount of increase during the interval divided by the number of units in the interval, or the amount of increase in the value of the function during the

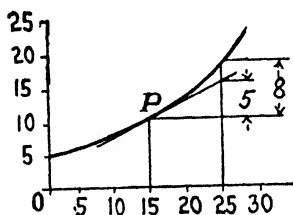

FIG. 497.

interval divided by the amount of increase in the value of the independent variable during that interval. Thus in the function illustrated in Fig. 497, the amount of increase in the function during the interval from  $x = 15$  to  $x = 25$  is 8 and the amount of increase in the value of the independent variable is, of course, 10.

The average rate of increase throughout this interval is  $\frac{8}{10}$  or .8.

In the same manner, we find the average rate of decrease throughout an interval, or as is more commonly done, the negative average rate of increase, since a decrease in the value of the function may be more easily considered as a negative increase.

**884. Instantaneous Rate of Change.**—A tangent to a curve at any point shows the instantaneous direction of the curve at that point. Since the direction, or slope, of a straight line is a measure of the rate of increase of the function which the line represents, the slope of the tangent represents the instantaneous rate of increase of the function represented by the curve at the point in question, or the tangent indicates the changes which would occur in the value of a function during an interval if it had continued to increase throughout the interval at the same rate as at the beginning of the interval. Thus, the instantaneous rate of change in the function of Fig. 497 at the point  $x = 15$  is .5.

The word "instantaneous" is perhaps misleading since any change, however small, requires an interval, however slight. It becomes necessary to examine the relations between the variables for very small intervals, and in these intervals it is, of course, the average rates of change throughout these small intervals with which we are concerned. In the consideration of the speed of a train, the speed at a certain instant cannot be taken as the number of miles traveled during an hour which contains the instant or even as the number of feet traversed during a second which contains the instant, although the smaller the interval, the more nearly the average rate for the interval approaches to the instantaneous rate at the beginning of the interval. We may, then, by shortening the interval and determining the average rate for the interval, come close at will to a determination of the exact instantaneous rate for the instant with which the interval started. In other words, the speed at any instant is the limiting values which the average speed approaches as the interval is made smaller and smaller, or is made to approach zero.

It is of the greatest importance to consider that the amount by which a variable differs from its limit is of no importance while the limit itself is the prime consideration. The notion that the difference between a variable and its limit may be made small at will and ultimately made to become negligible and be disregarded may be confusing and unsatisfactory to some, but if the limits only are considered, no difficulty should be experienced with the calculus.

**885. Magnitude.**—To define the magnitude of a quantity, we must make a comparison between it and some unit of the same kind. Comparing  $\frac{1}{1,000,000}$  with 1, we would say that the former was very small. If we compared 1 with 1,000,000 we would say that 1 was very small. If now we compared  $\frac{1}{1,000,000}$  with 1,000,000, we would undoubtedly say that the fraction was exceedingly small. The idea of magnitude is a very important one in the calculus, and we shall have occasion to become more familiar with it later on.

**886. Variables and Limits.**—As a demonstration of the manner in which a variable approaches a limit, consider the three points,  $A$ ,  $B_n$ , and  $C$ , on the line in Fig. 498.

Let the distance between  $A$  and  $C$  be 1 and suppose that the position of  $B_n$  is variable and during the first interval under consideration  $B_n$  lies midway between  $A$  and  $C$  at  $B_1$ .



FIG. 498.

During the next interval, the position of  $B_n$  changes from  $B_1$  to  $B_2$  which is midway between  $A$  and  $B_1$  and during the third interval, the position of  $B_n$  changes from  $B_2$  to  $B_3$ ,  $B_3$  being midway between  $B_2$  and  $A$ . It is evident that we can make the point  $B_n$  come close at will to  $A$  by taking a sufficiently large number of intervals. Thus for the first interval, the distance between  $A$  and  $B_n$  is equal to  $\frac{1}{2}$ ; for the second interval, the distance equals  $\frac{1}{4}$ ; for the third interval, it equals  $\frac{1}{8}$ ; for the fourth,  $\frac{1}{16}$ ; and so on. By taking a sufficiently large number of intervals, we may make the fraction which represents the distance of  $B_n$  from  $A$  resemble

a fraction like  $\frac{1}{1,000,000}$  or we may make it a fraction which represents any desired degree of smallness. When a variable decreases in this manner so that its value ultimately becomes and remains less than any arbitrary magnitude, however small, we say that the variable approaches zero as a limit.

Now consider the distance of the point  $B_n$  from the point  $C$ , as the number of intervals is allowed to increase. Thus:

For the first interval,  $B_1C = \frac{1}{2} = .5$ .

For the second interval,  $B_2C = \frac{3}{4} = .75$ .

For the third interval,  $B_3C = \frac{7}{8} = .875$ .

For the fourth interval,  $B_4C = \frac{15}{16} = .9375$ .

For the fifth interval,  $B_5C = \frac{31}{32} = .96875$ .

For the sixth interval,  $B_6C = \frac{63}{64} = .984375$ .

It is evident from the foregoing that the value of this distance from  $B_n$  to  $C$  approaches closer and closer to the value 1 as the number of intervals is allowed to increase, and the greater the number of intervals considered, the closer the value is to 1. Hence, 1 is the limiting value of the variable distance from  $B_n$

to  $C$ . By taking a sufficiently large number of intervals, we may make the value of the variable come close at will to 1. It is these limits, 0 and 1, with which we are concerned rather than the values of the fractions which represent the distances of  $B_n$  from  $A$  and  $C$ .

**887. Concept of a Limit.**—The following numerical example will aid in illustrating the concept of a variable and its limit:

A ball is thrown into the air and the relation between the height ( $h$ ) in feet and the time ( $t$ ) in seconds is given by

$$h = 150t - 16t^2.$$

Find the speed after 3 seconds.

Consider an interval of time beginning at 3 seconds and let .01 be the duration of the interval.

$$\text{If } t = 3, \quad h = 150(3) - 16(3)^2 = 306. \quad (1)$$

$$\text{If } t = 3.01, \quad h = 150(3.01) - 16(3.01)^2 = 306.5384. \quad (2)$$

The difference in  $h$  for a difference in  $t$  equal to .01 is .5384. The average rate of change throughout the interval from  $t = 3$  to  $t = 3.01$  is

$$\frac{.5384}{.01} = 53.84 \text{ feet per second.}$$

Let the duration of the interval become less and less, that is, approach the limit 0. In a manner similar to that used above, compute the average rate of change in  $h$  throughout the interval. Make a table of these average rates calling the difference in  $h$ ,  $\Delta h$ ; and the interval,  $\Delta t$ .

$\Delta t$	$\Delta h$	$\frac{\Delta h}{\Delta t}$
.01	.5384	53.84
.001	.053984	53.984
.0001	.00539984	53.9984
.00001	.0005399984	53.99984
.000001	.000053999984	53.999984

As  $\Delta t$  is taken smaller and smaller, the rate of increase  $\frac{\Delta h}{\Delta t}$  comes closer and closer to some limiting number, possibly 54.

To find the exact value of this limiting number, we may proceed as follows:

Suppose that instead of giving  $\Delta t$  a numerical value, we follow through the algebraic operation starting with the equation,

$$h = 150t - 16t^2. \quad (1)$$

If  $t$  is increased to  $t + \Delta t$ , then  $h$  increases to  $h + \Delta h$ , for the increase in  $t$  causes a change in  $h$  depending upon their algebraic relation.

$$\begin{aligned} h + \Delta h &= 150(t + \Delta t) - 16(t + \Delta t)^2. \\ &= 150t + 150\Delta t - 16t^2 - 32t\Delta t - 16\Delta t^2. \end{aligned} \quad (2)$$

Subtracting (1) from (2),

$$\Delta h = 150\Delta t - 32t\Delta t - 16\Delta t^2.$$

Dividing by  $\Delta t$ ,

$$\frac{\Delta h}{\Delta t} = 150 - 32t - 16\Delta t.$$

Now let  $\Delta t$  approach zero. Then

$$\text{the ratio } \frac{\Delta h}{\Delta t} \text{ approaches } 150 - 32t,$$

which is the limiting value approached by the average speed when  $\Delta t$  approaches zero and this limit is precisely  $150 - 32t$ , or, putting the same thing into different form, the expression  $150 - 32t - 16\Delta t$  gives the average rate of increase for any interval  $\Delta t$ , while the expression  $150 - 32t$  gives the exact rate of increase at the instant  $t$ .

For  $t = 3$ , this gives  $150 - 96 = 54$ , which was, therefore, the limit in the numerical case in the preceding paragraph.

Carefully note that the expression,

$$\frac{\Delta h}{\Delta t},$$

does not approach zero although both  $\Delta t$  and  $\Delta h$  approach zero as a limit.

It is absolutely necessary that the foregoing illustration be thoroughly understood. If difficulty is experienced, review the above example, extending the table if necessary, until it is evident that as  $\Delta t$  and  $\Delta h$  become small without limit, their ratio approaches some definite fixed value as a limit.

Consider the limit of an expression, such as

$$y = 10 + 1,000,000\Delta x + 1,000,000,000\Delta x^2.$$

We might not expect an expression with such large coefficients to approach 10 as a limit as  $\Delta x$  approaches zero, but let us investigate to find what does happen as we take  $\Delta x$  smaller and smaller.



$\Delta x = .1$	$y = 10 + 100,000 + 10,000,000 = 10,000,010$
$\Delta x = .01$	$y = 10 + 10,000 + 100,000 = 110,010$
$\Delta x = .001$	$y = 10 + 1,000 + 1,000 = 2,010$
$\Delta x = .0001$	$y = 10 + 100 + 10 = 120$
$\Delta x = .000001$	$y = 10 + 1 + .001 = 11.001$
$\Delta x = .000000001$	$y = 10 + .001 + .000000001 = 10.001000001$
$\Delta x = .000000000001$	$y = 10 + .000001 + .000000000000001$ $= 10.000001000000001$

By continually making  $\Delta x$  smaller, or making it approach zero as a limit, we may make  $y$  come close at will to 10. This example should help to make clear how it is that some expressions with exceedingly large coefficients may approach some small finite number as a limit when the variable is made to approach zero as a limit.

The symbol,  $\Delta x \rightarrow 0$ , or  $\Delta x \doteq 0$ , is read, "as delta  $x$  approaches zero as a limit" or "the limit of delta  $x$  is zero."

**888. Graphical Illustration.**—Let  $P$  ( $2, 1$ ) and  $P_1$  ( $2 + \Delta x, 1 + \Delta y$ ) be two points on a curve whose equation is  $y = f(x)$ , and let  $CD$  be the secant through these two points. Then, as will be seen from the figure,

$$\frac{\Delta y}{\Delta x}$$

is the slope of the secant  $CD$  through the points  $P$  and  $P_1$ .

This ratio also represents the average rate of increase of the function  $y$  for the interval  $\Delta x$ .

As  $\Delta x$  approaches the limiting value zero, the point  $P_1$  approaches the limiting position  $P$ , and the secant through  $PP_1$  revolves about  $P$  to the limiting position  $AB$ , which is the tangent to the curve at  $P$ . This tangent is the *exact limiting position* which the secant approaches as  $\Delta x$  approaches zero,

and the slope of the tangent is the *exact limit* which the value of  $\frac{\Delta y}{\Delta x}$  approaches as  $\Delta x$  approaches zero.

The slope of the tangent at any point is the slope of the curve at that point.

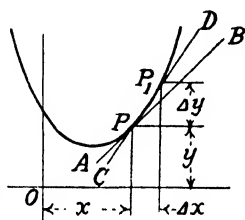

FIG. 499.

EXAMPLE.—Find the rate of change of the function  $y$ , with respect to  $x$  at the point  $x = 3$  when

$$4y = x^2 - 2x + 4. \quad (1)$$

Let  $(x_0, y_0)$  be some particular point on the curve, and then  $4y_0 = x_0^2 - 2x_0 + 4$ .

If another point on the curve is taken as  $(x_0 + \Delta x, y_0 + \Delta y)$ , the equation becomes

$$4(y_0 + \Delta y) = (x_0 + \Delta x)^2 - 2(x_0 + \Delta x) + 4 = \quad (2)$$

$$4y_0 + 4\Delta y = x_0^2 + 2x_0\Delta x + \Delta x^2 - 2x_0 - 2\Delta x + 4.$$

Subtracting (1) from (2),

$$4\Delta y = 2x_0\Delta x - 2\Delta x + \Delta x^2.$$

Dividing by  $4\Delta x$ ,

$$\frac{\Delta y}{\Delta x} = \frac{x_0}{2} - \frac{1}{2} + \Delta x.$$

When  $\Delta x$  approaches zero,

$$\frac{\Delta y}{\Delta x} \text{ approaches } \frac{x_0}{2} - \frac{1}{2}.$$

Then when  $x_0 = 3$ ,

$$\text{Limit of } \frac{\Delta y}{\Delta x} = \frac{3}{2} - \frac{1}{2} = 1,$$

which means that at the point of this curve for which  $x = 3$ , the rate of change of  $y$  is the same as that of  $x$ ; or that the slope of the tangent at that point is 1.

## CHAPTER XLII

### FUNDAMENTAL DIFFERENTIATION

**889. The Derivative.**—If there is given a function  $y$  of a variable  $x$ , and a pair of corresponding values of  $x$  and  $y$ ; and if then an increment  $\Delta x$  be given to  $x$  which brings about an increment  $\Delta y$  in  $y$ , the limiting value of the ratio,

$$\frac{\Delta y}{\Delta x},$$

as  $\Delta x$  approaches the limit zero is called the *derivative of  $y$  with respect to  $x$* .

The symbol for the derivative of  $y$  with respect to  $x$  is

$$\frac{dy}{dx}.$$

Another way of saying the same thing is

$$[459] \quad \frac{d[f(x)]}{dx} = \lim_{\Delta x \rightarrow 0} \left[ \frac{f(x + \Delta x) - f(x)}{\Delta x} \right].$$

Thus,

$$\begin{aligned} \frac{d(4x^2 + 3x)}{dx} &= \\ \lim_{\Delta x \rightarrow 0} \frac{[4(x + \Delta x)^2 + 3(x + \Delta x)] - [4x^2 + 3x]}{\Delta x} \end{aligned}$$

Or

$$[460] \quad \frac{dy}{dx} = \lim_{\Delta x \rightarrow 0} \frac{\Delta y}{\Delta x}.$$

**890. Importance of Limits.**—From what has already been said about limits, the reader will appreciate their importance and, if necessary, review those sections in which they have been treated (Art. 887).

A variable  $x$  is said to approach a constant limit  $C$ , if the difference between the variable and  $C$  ultimately becomes and remains less than any assignable number, however small. It will be understood that absolute values are considered without regard to their signs.

**897. Differentiation.**—The process of finding the derivative of a function is called *differentiation*. It is equivalent to finding an expression for an instantaneous rate, or speed, or slope.

The derivative  $\frac{dy}{dx}$  of a polynomial algebraic expression can always be found as in Art. 889, but quicker and less laborious methods will be given which will cover all the elementary types of expressions, such as algebraic, trigonometric, and logarithmic functions.

Since the expression  $\frac{dy}{dx}$  gives the slope of the locus when the coordinates of any particular point are substituted in it at any point, as  $(x_0, y_0)$ , then the equation of the tangent to the locus at that point is

$$[461] \quad y - y_0 = \left[ \frac{dy}{dx} \right]_{\substack{x=x_0 \\ y=y_0}} (x - x_0),$$

and the equation of the normal is

$$[462] \quad y - y_0 = - \left[ \frac{1}{\frac{dy}{dx}} \right]_{\substack{x=x_0 \\ y=y_0}} (x - x_0).$$

See Analytic Geometry (Arts. 795 to 798).

**892. Derivative of a Constant.**—The derivative of a constant is

$$\frac{dC}{dx} = 0.$$

Since  $C$  does not change as  $x$  changes by an amount  $\Delta x$ , the increment  $\Delta C$  is zero.

$$\frac{\Delta C}{\Delta x} = 0.$$

Therefore,

$$[463] \quad \frac{dC}{dx} = 0.$$

As  $y = C$  is the equation of a straight line parallel to the  $X$ -axis, the slope at any point is zero.

**893. Derivative of a Variable with Respect to Itself.**—The derivative of a variable with respect to itself is unity.

If  $y = x$ ,

$$\frac{dy}{dx} = \frac{dx}{dx} = 1,$$

because  $y = x$  and  $\Delta y = \Delta x$ ; hence,

$$\frac{\Delta y}{\Delta x} = \frac{\Delta x}{\Delta x} = 1.$$

Therefore,

$$\frac{dy}{dx} = 1.$$

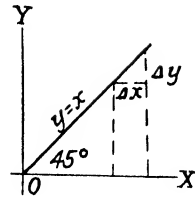

FIG. 500.

This will be apparent from Fig. 500.

**894. Effect of an Added Constant.**—Let

$F(x)$  represent some function of  $x$ .

Consider the equation,

$$y = F(x) + C.$$

Obviously  $C$  drops out in subtracting to get  $\Delta y$ , Art. 888. Then

$\frac{\Delta y}{\Delta x}$  and, hence,  $\frac{dy}{dx}$  have the same value as though we were differentiating  $y = F(x)$  alone.

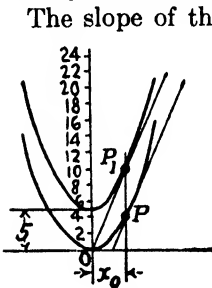

FIG. 501.

The slope of the tangents to the two curves of Fig. 501 at  $P$  and  $P_1$  are the same for any value  $x_0$  in the two equations. The added constant 5 simply shifts the curve upwards 5 units and does not change the slope of the tangent, since the curve has been displaced parallel to itself and the tangent remains parallel to its former position. Consequently, the value of the derivative  $\frac{dy}{dx}$  is the

same in both cases.

**895. Derivative of the Product of a Constant Times a Function of a Variable.**—The derivative of a constant times a function of a variable with respect to the variable itself equals the constant times the derivative of the function,

$$\frac{d[Cf(x)]}{dx} = C \frac{d[f(x)]}{dx}.$$

For, let  $y = Cf(x)$ .

Then  $y + \Delta y = Cf(x + \Delta x)$ .

And  $\Delta y = C[f(x + \Delta x) - f(x)]$ .

Then

$$\frac{\Delta y}{\Delta x} = C \frac{f(x + \Delta x) - f(x)}{\Delta x}.$$

Passing to the limit,

[464] 
$$\frac{dy}{dx} = C \frac{d[f(x)]}{dx}.$$

**896. Derivative of a Power.**—Take  $y = x^2$ .

Let  $x = x_0$ .

Then  $y_0 = x_0^2$ .

$$y_0 + \Delta y = (x_0 + \Delta x)^2 = x_0^2 + 2x_0\Delta x + \Delta x^2.$$

Subtracting  $y_0 = x_0^2$ ,

$$\Delta y = 2x_0\Delta x + \Delta x^2.$$

Dividing through by  $\Delta x$ ,

$$\frac{\Delta y}{\Delta x} = 2x_0 + \Delta x.$$

Let  $\Delta x$  approach the limit zero. Then  $\frac{dy}{dx} = 2x_0$  at any point  $x_0$ .

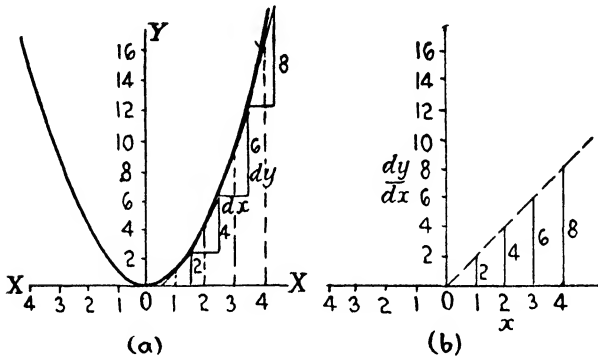

FIG. 502.

The rate of change of the ordinates at the point  $x = 2$  is 4 to 1.

The rate of change of the ordinates at the point  $x = 3$  is 6 to 1.

The rate of change of the ordinates at the point  $x = 4$  is 8 to 1.

In a manner similar to that used in the case where  $y = x^2$ , we find the derivative of  $y = x^3$ .

$$\frac{dy}{dx} = 3x_0^2 \text{ at any point } x_0,$$

and if  $y = x^4$ ,

$$\frac{dy}{dx} = 4x_0^3 \text{ at any point } x_0,$$

and, in general, if  $n$  is any positive integer and  $y = x^n$ ,

[465] 
$$\frac{dy}{dx} = nx_0^{n-1} \text{ at any point } x_0.$$

## CHAPTER XLIII

### DIFFERENTIATION OF ALGEBRAIC FUNCTIONS

**897. Differentiation of a Sum.**—If  $u$  is some function of  $x$  (as  $x^2$ ) and if  $v$  is another function of  $x$  (as  $2x$ ) and if

$$y = u + v,$$

then let  $\Delta y$ ,  $\Delta u$ , and  $\Delta v$ , be the increments of  $y$ ,  $u$ , and  $v$  corresponding to  $\Delta x$ , the increment of the independent variable.

Let  $x = x_0$ , that is, some definite value, and let  $u_0$ ,  $v_0$ , and  $y_0$  be the corresponding values of  $u$ ,  $v$ , and  $y$ .

Then

$$y_0 = u_0 + v_0.$$

Now let  $x = x_0 + \Delta x$ .

Then

$$y_0 + \Delta y = u_0 + \Delta u + v_0 + \Delta v.$$

Subtracting  $y_0 = u_0 + v_0$ ,

$$\Delta y = \Delta u + \Delta v.$$

Dividing by  $\Delta x$ ,

$$\frac{\Delta y}{\Delta x} = \frac{\Delta u}{\Delta x} + \frac{\Delta v}{\Delta x}.$$

Let  $\Delta x$  approach zero; then

$$[466] \quad \frac{dy}{dx} = \frac{du}{dx} + \frac{dv}{dx}.$$

The derivative of the sum of two functions is the sum of their derivatives.

In the same manner,

$$\frac{d(u + v - w)}{dx} = \frac{du}{dx} + \frac{dv}{dx} - \frac{dw}{dx}.$$

**EXAMPLE.**—Find the derivative of

$$y = x^3 + 2x^2 - 5x + 9.$$

This corresponds to

$$\begin{aligned} y &= u + v - w + c. \\ \frac{dy}{dx} &= \frac{d(x^3)}{dx} + \frac{d(2x^2)}{dx} - \frac{d(5x)}{dx} + \frac{d(9)}{dx}. \\ &= 3x^2 \frac{dx}{dx} + 4x \frac{dx}{dx} - 5 \frac{dx}{dx} + 0. \\ &= 3x^2 + 4x - 5. \end{aligned}$$

The derivative of the sum of any number of functions, whether designated by  $u, v, w$ , etc., or by  $F(x), f(x)$ , etc., or by  $x^2 + 2ax, x^3$ , or any other symbol which stands for an expression involving  $x$ , or the independent variable, equals the algebraic sum of their derivatives.

**898. Derivative of a Power.**—Let  $y = u^n$  where  $n$  is a positive integer and  $u$  is any function of  $x$ .

$$y + \Delta y = (u + \Delta u)^n.$$

Expanding  $(u + \Delta u)^n$  by the binomial theorem,

$$y + \Delta y = u^n + nu^{n-1}\Delta u + \frac{n(n-1)}{2} u^{n-2}\Delta u^2 + \dots + \Delta u^n.$$

Subtracting  $y = u^n$ ,

$$\Delta y = nu^{n-1}\Delta u + \frac{n(n-1)}{2} u^{n-2}\Delta u^2 + \dots + \Delta u^n.$$

Dividing by  $\Delta x$ ,

$$\frac{\Delta y}{\Delta x} = nu^{n-1} \frac{\Delta u}{\Delta x} + \frac{n(n-1)}{2} u^{n-2} \Delta u \frac{\Delta u}{\Delta x} + \dots + \Delta u^{n-1} \frac{\Delta u}{\Delta x}.$$

As  $\Delta x$  approaches zero,  $\Delta u$  also approaches zero, and

$$[467] \quad \frac{dy}{dx} = nu^{n-1} \frac{du}{dx}.$$

If  $u = x$  which is a special case, then

$$\begin{aligned} y &= x^n. \\ \frac{dy}{dx} &= nx^{n-1} \frac{dx}{dx} = nx^{n-1} [465]. \end{aligned}$$

It may be shown that the same formula holds when  $n$  is any constant, so that we have the rule:

The derivative of a function raised to a constant power, where the exponent may be positive, negative, fractional, or even irrational, is equal to the product of the exponent, the function raised to a power one less than the exponent, and the derivative of the function.



Thus, if  $n$  is a positive fraction  $\frac{p}{q}$ , then

$$y = u^{\frac{p}{q}}.$$

$$[468] \quad \frac{dy}{dx} = \frac{p}{q} u^{\frac{p}{q}-1} \times \frac{du}{dx}.$$

In the same manner, if  $n$  is negative or equals  $-m$ ,

$$y = u^{-m}.$$

$$\frac{dy}{dx} = -m u^{-m-1} \frac{du}{dx}.$$

$$\frac{dy}{dx} = n \cdot u^{n-1} \frac{du}{dx}.$$

If  $u = x$  and  $n = \frac{3}{4}$ ,

$$y = x^{\frac{3}{4}} \text{ and}$$

$$\frac{dy}{dx} = \frac{3}{4} x^{-\frac{1}{4}} \frac{dx}{dx} = \frac{3}{4} (x)^{-\frac{1}{4}}.$$

If  $y = \sqrt{x}$ ,  $y = x^{\frac{1}{2}}$ .

$$\frac{dy}{dx} = \frac{1}{2} (x)^{-\frac{1}{2}} = \frac{1}{2\sqrt{x}}.$$

If  $y = \frac{1}{x^3}$ ,  $y = x^{-3}$ ,

$$\frac{dy}{dx} = -3 \cdot x^{-4} = \frac{-3}{x^4}.$$

If  $y = (x^2 + 3)^3$ , this is in the form  $y = u^3$ .

$$\frac{dy}{dx} = 3u^2 \frac{du}{dx}.$$

$$\frac{du}{dx} = \frac{d(x^2 + 3)}{dx} = 2x.$$

$$\therefore \frac{dy}{dx} = 3(x^2 + 3)^2 \cdot 2x = 6x(x^2 + 3)^2.$$

**899. Differentiation of a Function of a Function.**—Let  $u$  be a function of  $x$ , and let  $y$  be a function of  $u$ .

Then  $u$  changes  $\frac{du}{dx}$  times as fast as  $x$ , and  $y$  changes  $\frac{dy}{du}$  times as fast as  $u$ . Therefore, it is evident that  $y$  changes  $\frac{dy}{du} \cdot \frac{du}{dx}$  times as fast as  $x$ . That is,

$$[469] \quad \frac{dy}{dx} = \frac{dy}{du} \cdot \frac{du}{dx}.$$

Reducing this to simple arithmetic, if  $y$  changes 4 times as fast as  $u$ , and if  $u$  changes 6 times as fast as  $x$ , then  $y$  changes  $4 \times 6 = 24$  times as fast as  $x$ .

Extending this to a function of a function of a function:

If  $x$  is a function of  $t$ , and  $z$  is a function of  $x$ , and if  $y$  is a function of  $z$ , then

$$[470] \quad \frac{dy}{dt} = \frac{dy}{dz} \cdot \frac{dz}{dx} \cdot \frac{dx}{dt}$$

Likewise, for any number of functions of functions, the form is

$$[471] \quad \frac{dy}{dt} = \frac{dy}{\dots} \dots \dots \frac{dx}{dt}$$

If  $t$  is the independent variable and  $y$  is the last variable function with intermediate functions, place the numerators and denominators in their proper places in the form shown.

EXAMPLE.—A steel rod is heated. Its length is a function of its temperature and the temperature is a function of the time. Its length is then a function of a function, of the independent variable  $t$ . The rate of change of length per second is equal to the rate of change of length per degree and the rate of change of temperature per second.

In the graph of a function of a function, the slope of  $y$  with respect to  $x$  equals the slope of  $y$  with respect to  $u$  times the slope of  $u$  with respect to  $x$ .

**900. Graphical Representation.**—A very clear method of showing the relations of functions of functions is to consider the relations of the three variables if  $x$  is a function of  $t$  and  $y$  is a function of  $x$ , on coordinate planes.

Do not confuse this relation with that represented by curve in space.

Let the rate of change of  $x$  with respect to  $t$  be

$$\frac{AB}{AC} = \frac{\Delta x}{\Delta t}$$

Let the rate of change of  $y$  with respect to  $x$  be

$$\frac{FE}{DE} = \frac{\Delta y}{\Delta x}$$

The rate of change of  $y$  with respect to  $t$  is

$$\frac{JG}{JH} = \frac{\Delta y}{\Delta t}$$

Then

$$\frac{JG}{JH} = \frac{AB}{AC} \cdot \frac{FE}{DE}, \quad \frac{\Delta y}{\Delta t} = \frac{\Delta y}{\Delta x} \cdot \frac{\Delta x}{\Delta t}.$$

Suppose that the rate of change between  $x$  and  $t$  is  $1\frac{1}{2}$  to 1. Take the base line to measure slope on  $OT$  equal to unity. Then  $AC = 1$  and  $AB = 1\frac{1}{2}$ . Also  $DE = 1\frac{1}{2}$ .

Suppose that the rate of change between  $y$  and  $x$  is 2 to 1. Then  $EF = 1\frac{1}{2} \times 2 = 3$ .

But  $EF = JG = 3$ . Also  $JH = 1$ , being equal to the unit on the  $T$ -axis with which we started. Hence,

$$\frac{JG}{JH} = \frac{3}{1} = 1\frac{1}{2} \times 2.$$

EXAMPLE.—Differentiate

$$y = \sqrt{a+x} = (a+x)^{\frac{1}{2}}.$$

Let  $(a+x) = u$ .

Then  $\frac{du}{dx} = 1$ .

And  $y = u^{\frac{1}{2}}, \frac{dy}{du} = \frac{1}{2}u^{-\frac{1}{2}}$ .

$$\frac{dy}{dx} = \frac{dy}{du} \cdot \frac{du}{dx} = \frac{1}{2}u^{-\frac{1}{2}} \times 1.$$

Substituting value of  $u$  above,

$$\frac{dy}{dx} = \frac{1}{2}(a+x)^{-\frac{1}{2}} = \frac{1}{2\sqrt{a+x}}.$$

**901.** The derivative of a function raised to a power may be found by using the formula for the derivative of a function of a function.

Let  $y = u^n$  with  $n$  a positive integer and  $u$  any function of  $x$ .

From the formula for the derivative of a function of a function,

$$\frac{dy}{dx} = \frac{dy}{du} \cdot \frac{du}{dx} \quad [469].$$

If  $x$  is given an increment  $\Delta x$ , then  $y$  and  $u$  are increased by  $\Delta y$  and  $\Delta u$ , respectively, or

$$y + \Delta y = (u + \Delta u)^n.$$

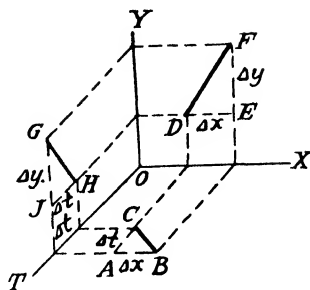

FIG. 503.

Expanding  $(u + \Delta u)^n$  by the binomial theorem,

$$y + \Delta y = u^n + n \cdot u^{n-1} \Delta u + \frac{n(n-1)}{2} \cdot u^{n-2} \Delta u^2 + \dots + \Delta u^n.$$

Subtracting  $y = u^n$ ,

$$\Delta y = n \cdot u^{n-1} \Delta u + \frac{n(n-1)}{2} \cdot u^{n-2} \Delta u^2 + \dots + \Delta u^n.$$

Dividing by  $\Delta u$ ,

$$\frac{\Delta y}{\Delta u} = n \cdot u^{n-1} + \frac{n(n-1)}{2} \cdot u^{n-2} \Delta u + \dots + \Delta u^{n-1}.$$

As  $\Delta u$  approaches zero,

$$\frac{\Delta y}{\Delta u} \text{ approaches } n \cdot u^{n-1}.$$

Therefore,  $\frac{dy}{du} = n \cdot u^{n-1}$ .

Substitute this value in

$$\frac{dy}{dx} = \frac{dy}{du} \cdot \frac{du}{dx} \text{ [469].}$$

Then

$$\frac{dy}{dx} = n \cdot u^{n-1} \frac{du}{dx} \text{ [467].}$$

**902. The Derivative of the Product of Two Functions.**—Consider two functions of  $x$ , as  $(x^2 + 3)$  and  $(x^2 + 5x + 9)$ .

The product would be indicated as

$$y = (x^2 + 3)(x^2 + 5x + 9).$$

We could, of course, perform the indicated multiplication and then find the derivative of the product but a shorter method is as follows:

$$\text{Let } y = u \times v,$$

where  $u$  and  $v$  represent the two functions which are factors.

Let  $x = x_0$ ; that is, let  $x$  have some definite value.

Then  $y_0 = u_0 \times v_0$ .

Let  $x$  take on an increment  $\Delta x$ ; then

$$\begin{aligned} y_0 + \Delta y &= (u_0 + \Delta u)(v_0 + \Delta v). \\ &= u_0 v_0 + v_0 \Delta u + u_0 \Delta v + \Delta u \Delta v. \end{aligned}$$

Subtracting  $y_0 = u_0 v_0$ ,

$$\Delta y = v_0 \Delta u + u_0 \Delta v + \Delta u \Delta v.$$

Dividing by  $\Delta x$ ,

$$\frac{\Delta y}{\Delta x} = v_0 \frac{\Delta u}{\Delta x} + u_0 \frac{\Delta v}{\Delta x} + \Delta u \frac{\Delta v}{\Delta x}.$$

Let  $\Delta x$  approach zero.

Then  $\Delta u \frac{\Delta v}{\Delta x}$  also approaches zero, and

[472] 
$$\frac{dy}{dx} = v \frac{du}{dx} + u \frac{dv}{dx}.$$

Applying this formula to the example at the beginning of the article:

Let  $u = x^2 + 3$ .

$v = x^2 + 5x + 9$ .

Then

$$\frac{dy}{dx} = (x^2 + 3) \frac{d(x^2 + 5x + 9)}{dx} + (x^2 + 5x + 9) \frac{d(x^2 + 3)}{dx}.$$

$$\frac{d(x^2 + 5x + 9)}{dx} = 2x + 5, \quad \frac{d(x^2 + 3)}{dx} = 2x.$$

$$\begin{aligned} \frac{dy}{dx} &= (x^2 + 3)(2x + 5) + (x^2 + 5x + 9)(2x) \\ &= 4x^3 + 15x^2 + 24x + 15. \end{aligned}$$

Multiplying the functions together before differentiating gives  $x^4 + 5x^3 + 12x^2 + 15x + 27$ . Differentiating this as a sum gives, as the derivative,  $4x^3 + 15x^2 + 24x + 15$ . This is the same result as was obtained by the use of the formula for the derivative of a product.

EXAMPLE.—Differentiate  $y = (x + 1)^5(2x - 1)^3$ .

$$\frac{dy}{dx} = (x + 1)^5 \cdot \frac{d(2x - 1)^3}{dx} + (2x - 1)^3 \cdot \frac{d(x + 1)^5}{dx}.$$

$$= (x + 1)^5 \cdot 3(2x - 1)^2 \cdot \frac{d(2x - 1)}{dx} +$$

$$(2x - 1)^3 \cdot 5(x + 1)^4 \cdot \frac{d(x + 1)}{dx}.$$

$$= 6(x + 1)^5(2x - 1)^2 + 5(2x - 1)^3(x + 1)^4.$$

$$= (2x - 1)^2(x + 1)^4(16x + 1).$$

In the graph of  $y = uv$ , the slope of the curve is equal to  $u$  times the slope of  $v = f(x)$  plus  $v$  times the slope of  $u = F(x)$ .

The derivative of the product of two functions is equal to the first times the derivative of the second plus the second times the derivative of the first.

**903. Example of the Product of Two Functions.**—Let  $x$  and  $y$  be the two variable sides of a rectangle and suppose that we desire to know the rate at which the area (product of the two sides) varies with respect to the time when the length of the sides are functions of the time.

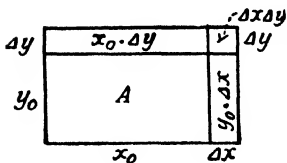

FIG. 504.

Let  $A_0$  = area and  $x_0$ ,  $y_0$  the two sides at a certain time  $t_0$ . After an interval of time  $\Delta t$ , that is, at the time  $t_0 + \Delta t$ , we would have

$$A_0 + \Delta A = (x_0 + \Delta x)(y_0 + \Delta y) = x_0 y_0 + x_0 \Delta y + y_0 \Delta x + \Delta x \Delta y.$$

$$\Delta A = x_0 \Delta y + y_0 \Delta x + \Delta x \Delta y.$$

Since each variable varies with respect to the time  $t$ , then

$$\frac{\Delta A}{\Delta t} = x_0 \frac{\Delta y}{\Delta t} + y_0 \frac{\Delta x}{\Delta t} + \Delta x \frac{\Delta y}{\Delta t}.$$

This is the average rate at which the area varies with respect to the time as each side varies in some manner with respect to the time. The instantaneous rate of change of the area with respect to the time is the limit of this expression as  $\Delta t$  approaches zero. This limit is

$$\frac{dA}{dt} = x \frac{dy}{dt} + y \frac{dx}{dt},$$

or the length times the rate of change of the width plus the width times the rate of change of the length.

EXAMPLE.

$$y = \sqrt{\frac{x^3}{1+x^2}}.$$

Find its derivative.

This expression may be written,  $y = x^{\frac{3}{2}}(1+x^2)^{-\frac{1}{2}}$ .

From the formula for the differentiation of a product,

$$\frac{dy}{dx} = x^{\frac{3}{2}} \cdot \frac{d(1+x^2)^{-\frac{1}{2}}}{dx} + (1+x^2)^{-\frac{1}{2}} \cdot \frac{d(x^{\frac{3}{2}})}{dx}.$$

$$\frac{d(1+x^2)^{-\frac{1}{2}}}{dx} = -\frac{1}{2}(1+x^2)^{-\frac{3}{2}} \cdot 2x = -\frac{x}{(1+x^2)^{\frac{3}{2}}}.$$

$$\frac{d(x^{\frac{3}{2}})}{dx} = \frac{3}{2}x^{\frac{1}{2}}.$$

$$\therefore \frac{dy}{dx} = \frac{-x^{\frac{3}{2}}}{(1+x^2)^{\frac{3}{2}}} + \frac{3x^{\frac{3}{2}}}{2(1+x^2)^{\frac{3}{2}}}.$$

$$= \frac{3\sqrt{x}}{2\sqrt{1+x^2}} - \frac{\sqrt{x^3}}{\sqrt{(1+x^2)^3}}.$$

**904. The Derivative of the Product of More Than Two Functions.**—The derivative of the product of a finite number of functions is the sum of the products obtained by multiplying the derivative of each function by the product of all the remaining functions. Thus, if

$$y = uvw,$$

$$[473] \quad \frac{dy}{dx} = vw \frac{du}{dx} + uw \frac{dv}{dx} + uv \frac{dw}{dx}.$$

**905. Another Form of the Formula for the Derivative of a Product.**—If

$$y = uv,$$

$$\frac{dy}{dx} = u \frac{dv}{dx} + v \frac{du}{dx}.$$

Dividing through by  $y$ ,

$$\frac{1}{y} \cdot \frac{dy}{dx} = \frac{u}{y} \cdot \frac{dv}{dx} + \frac{v}{y} \cdot \frac{du}{dx}.$$

$$[474] \quad = \frac{1}{v} \cdot \frac{dv}{dx} + \frac{1}{u} \cdot \frac{du}{dx}.$$

In the same manner, if

$$y = uvw,$$

$$[475] \quad \frac{1}{y} \cdot \frac{dy}{dx} = \frac{1}{u} \cdot \frac{du}{dx} + \frac{1}{v} \cdot \frac{dv}{dx} + \frac{1}{w} \cdot \frac{dw}{dx}.$$

Each term involves only one variable, which makes it an easy operation to build up the derivative for the product of any number of variables.

**906. The Derivative of the Quotient of Two Functions.**

$$\text{Given } y = \frac{u}{v}.$$

Let  $x = x_0$ ; then

$$y_0 + \Delta y = \frac{u_0 + \Delta u}{v_0 + \Delta v}.$$

Subtracting,

$$\Delta y = \frac{u_0 + \Delta u}{v_0 + \Delta v} - \frac{u_0}{v_0} = \frac{v_0 \Delta u - u_0 \Delta v}{v_0(v_0 + \Delta v)}.$$

Dividing by  $\Delta x$ ,

$$\frac{\Delta y}{\Delta x} = \frac{v_0 \frac{\Delta u}{\Delta x} - u_0 \frac{\Delta v}{\Delta x}}{v_0(v_0 + \Delta v)}.$$

Now let  $\Delta x$  approach zero. Then

$$[476] \quad \frac{dy}{dx} = \frac{d\left(\frac{u}{v}\right)}{\frac{dx}{dx}} = \frac{v \frac{du}{dx} - u \frac{dv}{dx}}{v^2}.$$

EXAMPLE.—Differentiate

$$y = \frac{x-1}{2x}.$$

$$\frac{dy}{dx} = \frac{2x \frac{d(x-1)}{dx} - (x-1) \frac{d(2x)}{dx}}{4x^2}.$$

$$\frac{d(x-1)}{dx} = 1, \quad \frac{d(2x)}{dx} = 2.$$

$$\therefore \frac{dy}{dx} = \frac{2x - 2(x-1)}{4x^2} = \frac{1}{2x^2}.$$

EXAMPLE.—Differentiate

$$y = \sqrt{\frac{1-x}{1+x}}.$$

Put into the form,

$$y = \frac{(1-x)^{\frac{1}{2}}}{(1+x)^{\frac{1}{2}}}.$$

Since this is the quotient of two functions,

$$\frac{dy}{dx} = \frac{(1+x)^{\frac{1}{2}} \frac{d(1-x)^{\frac{1}{2}}}{dx} - (1-x)^{\frac{1}{2}} \frac{d(1+x)^{\frac{1}{2}}}{dx}}{1+x}.$$

$$\frac{d(1-x)^{\frac{1}{2}}}{dx} = \frac{1}{2}(1-x)^{-\frac{1}{2}} \left(-\frac{dx}{dx}\right) = \frac{-1}{2\sqrt{1-x}}.$$

$$\frac{d(1+x)^{\frac{1}{2}}}{dx} = \frac{1}{2}(1+x)^{-\frac{1}{2}} \left(\frac{dx}{dx}\right) = \frac{1}{2\sqrt{1+x}}.$$

$$\begin{aligned} \therefore \frac{dy}{dx} &= \frac{-\sqrt{1+x}}{2\sqrt{1-x}(1+x)} - \frac{\sqrt{1-x}}{2\sqrt{1+x}(1+x)} \\ &= \frac{-1}{(1+x)\sqrt{1-x^2}}. \end{aligned}$$

### 907. Slope of the curve of general form,

$$Ax^2 + Bxy + Cy^2 + Dx + Ey + F = 0,$$

at any point  $P_1(x_1, y_1)$  on the curve.

Take another point on the curve, as  $Q(x_1 + \Delta x, y_1 + \Delta y)$ , near the first point and then substitute the coordinates of both points in the general equation.

$$Ax_1^2 + Bx_1y_1 + Cy_1^2 + Dx_1 + Ey_1 + F = 0. \quad (1)$$

$$A(x_1 + \Delta x)^2 + B(x_1 + \Delta x)(y_1 + \Delta y) + C(y_1 + \Delta y)^2 + D(x_1 + \Delta x) + E(y_1 + \Delta y) + F = 0. \quad (2)$$



Simplify (2) and then subtract (1) from (2);

$$\Delta y(Bx_1 + B\Delta x + 2Cy_1 + C\Delta y + E) = -\Delta x(2Ax_1 + A\Delta x + By_1 + D).$$

Then

$$\frac{\Delta y}{\Delta x} = -\frac{2Ax_1 + A\Delta x + By_1 + D}{Bx_1 + B\Delta x + 2Cy_1 + C\Delta y + E}.$$

Now as the point  $Q$  approaches the point  $P_1$ ,  $\Delta x$  and  $\Delta y$  approach zero and the limit of the ratio,

$\frac{\Delta y}{\Delta x}$  is  $m$ , the slope of the tangent at the point  $P_1$ .

Then

$$[477] \quad m = \frac{dy}{dx} = -\frac{2Ax_1 + By_1 + D}{2Cy_1 + Bx_1 + E}, \quad (3)$$

which is the slope of the curve at the point  $P_1(x_1, y_1)$ .

The equation of the tangent to  $Ax^2 + Bxy + Cy^2 + Dx + Ey + F = 0$  at  $(x_1, y_1)$  is, therefore,

$$[478] \quad y - y_1 = -\frac{2Ax_1 + By_1 + D}{2Cy_1 + Bx_1 + E}(x - x_1),$$

or

$$2Cy_1y + Bx_1y + Ey - 2Cy_1^2 - Bx_1y_1 - Ey_1 = -2Ax_1x - By_1x - Dx + 2Ax_1^2 + Bx_1y_1 + Dx_1,$$

or

$$2Ax_1x + B(x_1y + y_1x) + 2Cy_1y + Dx + Ey = 2Ax_1^2 + 2Bx_1y_1 + 2Cy_1^2 + Dx_1 + Ey_1.$$

Now add  $Dx_1 + Ey_1 + 2F$  to both sides, and the equation becomes

$$2Ax_1x + B(x_1y + y_1x) + 2Cy_1y + D(x + x_1) + E(y + y_1) + 2F = 2Ax_1^2 + 2Bx_1y_1 + 2Cy_1^2 + 2Dx_1 + 2Ey_1 + 2F,$$

or

$$Ax_1x + B\frac{x_1y + y_1x}{2} + Cy_1y + D\frac{x + x_1}{2} + E\frac{y + y_1}{2} + F = Ax_1^2 + Bx_1y_1 + Cy_1^2 + Dx_1 + Ey_1 + F.$$

But since  $(x_1, y_1)$  lies on the curve, and from (1) the right side is zero, hence the equation of the tangent is

$$[479] \quad Ax_1x + B\frac{x_1y + y_1x}{2} + Cy_1y + D\frac{x + x_1}{2} + E\frac{y + y_1}{2} + F = 0.$$

That is, it is the same as the equation of the curve itself if we replace

$$\begin{aligned} x^2 &\text{ by } x_1x. \\ y^2 &\text{ by } y_1y. \\ xy &\text{ by } \frac{y_1x + x_1y}{2}. \\ x &\text{ by } \frac{x + x_1}{2}. \\ y &\text{ by } \frac{y + y_1}{2}. \end{aligned}$$

Hence, we have proved the rule stated in Art. 796. All examples of tangents to conics can be done more easily by this method than in any other way.

EXAMPLE.—Find the equation of the tangent to the curve.

$$x^2 + xy + 4y^2 - 2x - 2y - 12 = 0,$$

at  $x = 2$ .

Substituting in the equation to find the corresponding values of  $y$ ,

$$4 + 2y + 4y^2 - 4 - 2y - 12 = 0.$$

$$4y^2 = 12.$$

$$y = \pm\sqrt{3}.$$

Then the tangent at  $(2, \sqrt{3})$  is

$$2x + \frac{2y + \sqrt{3}x}{2} + 4\sqrt{3}y - (x + 2) - (y + \sqrt{3}) - 12 = 0, \text{ [479]}$$

and at  $(2, -\sqrt{3})$  it is the same except for the change of sign of  $\sqrt{3}$  all the way through.

**908. Differentiation of Implicit Functions.**—In all previous cases except that of the last article, the function has been defined as an explicit function of the independent variable. Suppose now that  $y$  is an implicit function of  $x$  given by such an equation as

$$x^2 + y^2 = 9.$$

We can put this into the explicit form,

$$y = \pm\sqrt{9 - x^2},$$

or

$$x = \pm\sqrt{9 - y^2}.$$

From the first equation,  $y$  is an explicit function of  $x$ , and from the second,  $x$  is an explicit function of  $y$ . It is not necessary, however, to express the relation between the variables explicitly in order to perform the differentiation.

Differentiate both sides of the equation with respect to  $x$ ; then

$$\frac{d(x^2)}{dx} + \frac{d(y^2)}{dx} = 0.$$

$$2x \frac{dx}{dx} + 2y \frac{dy}{dx} = 0.$$

$$\frac{dy}{dx} = -\frac{2x}{2y} = -\frac{x}{y}.$$

If the variables are so involved in an equation that  $y$  cannot readily be expressed as a function of  $x$ , we may find the derivative of  $y$  with respect to  $x$  according to the following method.

Set the function equal to zero, and differentiate each term.

Collect all terms containing  $\frac{dy}{dx}$  and transpose to the left side of the equation. Transpose all other terms to the other member. Take  $\frac{dy}{dx}$  as a factor from the left side of the equation and divide both members by the other factor of the left member. The method will be apparent from inspection of the following example.

EXAMPLE.—Differentiate

$$3x^3 + 5x^2y + 7xy^2 + 10y^3 + 25 = 0.$$

Differentiate each term.

$$\frac{d(3x^3)}{dx} = 9x^2.$$

$$\frac{d(5x^2y)}{dx} = 5x^2 \frac{dy}{dx} + 10xy.$$

$$\frac{d(7xy^2)}{dx} = 7x \cdot 2y \frac{dy}{dx} + 7y^2 = 14xy \frac{dy}{dx} + 7y^2.$$

$$\frac{d(10y^3)}{dx} = 30y^2 \frac{dy}{dx}.$$

Collecting and adding,

$$5x^2 \frac{dy}{dx} + 14xy \frac{dy}{dx} + 30y^2 \frac{dy}{dx} = -(9x^2 + 10xy + 7y^2).$$

Factoring,

$$\frac{dy}{dx}(5x^2 + 14xy + 30y^2) = -(9x^2 + 10xy + 7y^2),$$

whence

$$\frac{dy}{dx} = -\frac{9x^2 + 10xy + 7y^2}{5x^2 + 14xy + 30y^2}.$$

**909. Differentiation of General Equation of Conic.**—The general equation of a conic is

$$Ax^2 + Bxy + Cy^2 + Dx + Ey + F = 0.$$

Bearing in mind that the second term is the product of two variables, its differentiation will be

$$B\left[x\frac{dy}{dx} + y\frac{dx}{dx}\right].$$

Proceeding now with the differentiation of the equation,

$$A\frac{d(x^2)}{dx} + Bx\frac{dy}{dx} + By\frac{dx}{dx} + C\frac{d(y^2)}{dx} + D\frac{dx}{dx} + E\frac{dy}{dx} + G = 0.$$

Then

$$2Ax\frac{dx}{dx} + Bx\frac{dy}{dx} + By\frac{dx}{dx} + 2Cy\frac{dy}{dx} + D\frac{dx}{dx} + E\frac{dy}{dx} = 0,$$

or

$$2Ax + Bx\frac{dy}{dx} + By + 2Cy\frac{dy}{dx} + D + E\frac{dy}{dx} = 0.$$

Collecting,

$$\frac{dy}{dx} = -\frac{2Ax + By + D}{2Cy + Bx + E},$$

which agrees with the result obtained in Art. 907.

**910. A Derivative of a Derivative.**—Since the derivative is, in general, some function of the independent variable, its derivative may be found and this derivative of a derivative is called the *second derivative* of the original function.

If  $y = f(x)$ , then

$$\frac{d(f[x])}{dx} = \frac{dy}{dx},$$

and

$$\frac{d\left(\frac{dy}{dx}\right)}{dx} \text{ is denoted by the symbol } \frac{d^2y}{dx^2}.$$

This does not mean that the second derivative is the square of the first derivative but that a second differentiation is performed in which the derivative of the original function is considered as the dependent variable and differentiated with respect to the independent variable. Another notation is used commonly in which

$f(x)$  denotes the function,

$f'(x)$  denotes its derivative, and

$f''(x)$  denotes the derivative of  $f'(x)$ ,

which is called the *second derivative* of  $f(x)$ .

In the same manner, the derivative of  $f''(x)$  is called the *third* derivative of  $f(x)$  and is denoted by  $f'''(x)$ , or

$$\frac{d^3y}{dx^3}.$$

EXAMPLE.—If

$$y = x^6 + \frac{1}{x^3},$$

$$\frac{dy}{dx} = 6x^5 - 3x^{-4},$$

$$\frac{d^2y}{dx^2} = 30x^4 + 12x^{-5},$$

$$\frac{d^3y}{dx^3} = 120x^3 - 60x^{-6}.$$

**911. Successive Differentiation.**—This process of finding the derivative of the derivative or the derivative of a derivative of higher order than the first is called *successive differentiation*.

EXAMPLE.

$$y = x^n.$$

$$\frac{dy}{dx} = nx^{n-1}.$$

$$\frac{d^2y}{dx^2} = n(n-1)x^{n-2}.$$

$$\frac{d^3y}{dx^3} = n(n-1)(n-2)x^{n-3}.$$

$$\frac{d^r y}{dx^r} = n(n-1)(n-2)(n-3) \dots (n-r+1)x^{n-r}.$$

If  $r = n$  and is a positive integer, then

$$\frac{d^n y}{dx^n} = n(n-1)(n-2)(n-3) \dots 1 = |n|.$$

**912. Graphs of Derivatives.**—In the analytical geometry section, the general forms of the quadratic, cubic, and power equations are given, and their relations to each other due to translation were shown. These laws can be used to determine the relation of curves to their derived curves.

In differentiating a function of the form,  $y =$  a polynomial in  $x$ , we have learned that the derived curve is a curve of degree one less than the degree of the primary function. The derived

curve of a parabola is a straight line and the derived curve of a cubic is a quadratic, since it is quadratic in  $x$ .

The following examples show the successive derived curves of a simple power function:

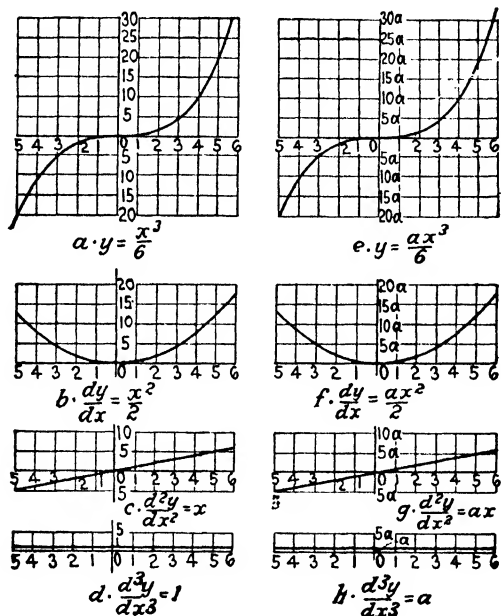

FIG. 505.

### 913. The Graph of the Derivative of the Standard Quadratic Equation $y = ax^2 + bx + c$ .

By the analytical method,

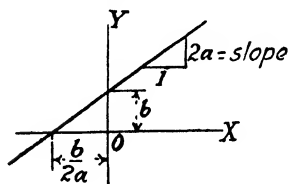

FIG. 506.

$$\frac{dy}{dx} = 2ax + b.$$

This, then, indicates that the derived curve is a straight line whose equation is

$$y = 2ax + b,$$

with slope equal to  $2a$ , with Y-intercept equal to  $b$ , and with X-intercept equal to  $-\frac{b}{2a}$ .

with slope equal to  $2a$ , with Y-intercept equal to  $b$ , and with X-intercept equal to  $-\frac{b}{2a}$ .

EXAMPLE.—Draw the derived curve of

$$y = x^2 + 12x + 32.$$

$$a = 1, b = 12, c = 32.$$

$$\frac{-b}{2a} = \frac{-12}{2} = -6.$$

Slope  $m = 2$ .

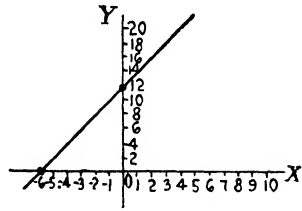

FIG. 507.

**914. The Graph of the Derivative of the Cubic Equation,  $y = ax^3 + bx^2 + cx + d$ .**

From the analytical method,

$$\frac{dy}{dx} = 3ax^2 + 2bx + c$$

If we plot the values of  $\frac{dy}{dx}$  as ordinates, the curve is a parabola, since

$$y = 3ax^2 + 2bx + c$$

is the explicit form of the equation of the parabola. Now by taking a standard  $y = x^2$  graph and translating the origin to the point  $(h, k)$  and then multiplying the ordinates by  $a'$ , we have a curve represented by the equation,

$$y = a'x^2 + b'x + c',$$

where

$$h = \frac{b'}{2a'}, \quad [4] \quad k = \frac{b'^2 - 4a'c'}{4a'}. \quad [5]$$

Comparing this general equation with the equation of the derived curve of the cubic, we see that

$$\begin{aligned} y &= 3ax^2 + 2bx + c. \\ y &= a'x^2 + b'x + c'. \\ a' &= 3a, \quad b' = 2b, \quad c' = c. \end{aligned}$$

The formulae for  $h$  and  $k$ , when these values are substituted, become

$$[480] \quad h = \frac{b}{3a}, \quad k = \frac{b^2 - 3ac}{3a}.$$

By the use of these transformation equations, the standard graph of  $y = x^2$  can be made to represent the derived curve of any cubic equation.

If  $h$  is positive, locate the new origin in the positive direction. The direction of  $k$  is likewise as indicated by its sign.

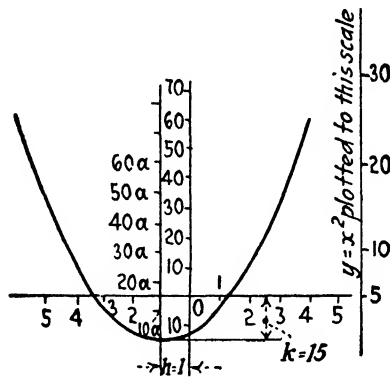

FIG. 508.

Also note that the vertical scale for  $y = x^2$  is multiplied by  $3a$  and that  $h$  and  $k$  are measured according to this new scale.

By having a few graphs of this equation,  $y = x^2$ , on hand, the graph of the derived curve of any cubic equation of this form can be quickly made by finding the new origin and constructing the new scale. Fig. 508 shows derived curve of  $y = x^3 + 3x^2 - 12x$ .

**915. The Graph of the Derivative of Equations of the Form**  
 $y = ax^4 + bx^3 + cx^2 + dx + e$ .

From the analytical method,

$$\frac{dy}{dx} = 4ax^3 + 3bx^2 + 2cx + d.$$

This is a cubic equation.

From Art. 237, a graph of  $y = x^3$  can be used by transposing the origin and shearing, but the transposing equations are for the form,

$$y = a'x^3 + b'x^2 + c'x + d'.$$

By substituting an  $a$  value four times greater, a  $b$  value three times greater, and a  $c$  value two times greater in the equations of transformation, we can find an origin and a shear for which the graph will represent the derived curve of an equation of the fourth degree.



The equations of transformation become

$$h = \frac{b}{4a}, \quad k = \frac{bc}{2a} - \frac{b^3}{8a^2} - d = -\frac{b}{2a} \left( \frac{b^2 - 4ac}{4a} \right) - d.$$

[481]

$$m = \text{slope line of shear} = 2c - \frac{3b^2}{4a}.$$

EXAMPLE.—Differentiate graphically  $y = \frac{x^4}{2} + x^3 - 18x^2 - 15x$ .

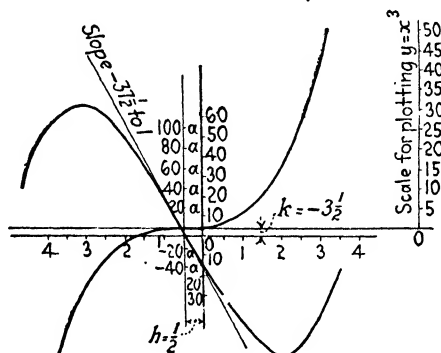

FIG. 509.

**916. Graphical Differentiation.**—Graphical differentiation is simply forming a new curve by erecting ordinates found from the slope of the given curve at various points. If a given curve (Fig. 510) is to be graphically differentiated, then by accurately drawing tangent lines to the curve at the points 1, 2, 3, etc., and taking the ratio of the vertical to the horizontal side of the triangles as shown, this ratio or the slope plotted as ordinate for that point will locate the derived curve. In the given case, the horizontal distance in each triangle is unity; therefore, the vertical heights are the ordinates.

Thus, the ordinate at  $x = 0$  is  $aa'$  and the ordinate at  $x = 1$  is  $bb'$ , etc.

By drawing a smooth curve through these ordinate ends, the derived curve is formed. Care must be taken that positive and negative slopes are used.

Unfortunately, it is very difficult to draw a tangent to a curve sufficiently

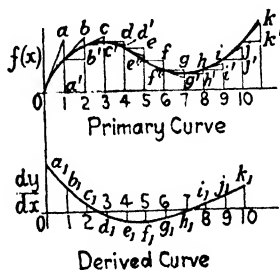

FIG. 510.

accurate, and other schemes using this same principle are better adapted to the purpose and will be explained later.

Do not lose sight of the fact that the ordinates of the derived curve really show the *instantaneous rate of change* at which the ordinate of the primary curve is increasing per unit of increase in the abscissa.

**917. To Draw a Tangent at a Point on a Curve.**—Take a compass or a divider and locate the center of curvature. Then with the edge of a triangle on the line of the point of tangency and this center, put a straight edge on the hypotenuse of the triangle, then slide the triangle to the position *ABC*, and draw *AB* the tangent at *P*.

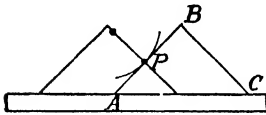

FIG. 511.

**918. Comparison of the Primary and the Derived Curves.** Take *P* and *Q*, two points very near together. From Art. 888, the secant *PQ* approaches the tangent or slope of the curve at *P* as *Q* is taken nearer and nearer to *P* and represents the average rate of change for the small interval *PK*.

Then the ratio

$$\frac{QK}{PK} = \frac{QK}{pq} = p'P',$$

the average rate of change.

Therefore,

$$QK = pq \times p'P'.$$

From this relation, the distance *QK* equals the area of the strip *p'P'*, by *p'q'*.

In the same manner, the area of the succeeding strips equals *RL*, *SM*, *TN*, etc., or

$$\begin{aligned} QK + RL + SM + TN + \dots &= \text{area of strips.} \\ &= p'P' \times p'q' + q'Q' \times q'r' + r'R' \times r's' + \dots \end{aligned}$$

If the thickness of the strip is continually decreased or the number of them increased, the sum of the partial ordinates will remain the distance *BU* in the primary curve, and the area of the strips will approach the area under the derived curve as a limit.

This important comparison shows that the difference in length

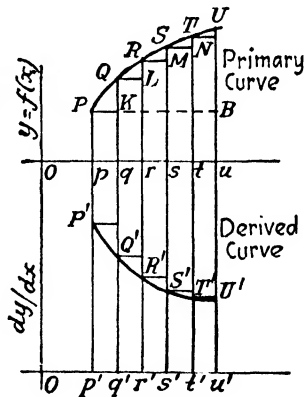

FIG. 512.

of ordinates of the primary curve equals the area between the ordinates, the derived curve, and the X-axis.

$$UB = \text{area } p'P'U'u'.$$

Use is made of this last relation in graphical differentiation. From the difference in length of ordinates of the primary curve, areas of strips are drawn, and an average curve drawn through the strips.

EXAMPLE.—Given the curve *OABCD*. To differentiate graphically.

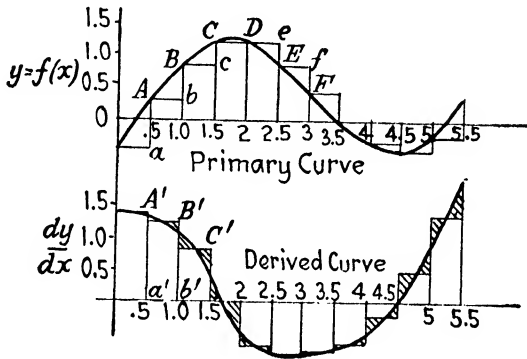

FIG. 513.

First, divide into strips .5 unit wide. The first ordinate is shown at *A* and the ordinate of the derived curve must be of such a height that the area in square units equals the length of the ordinate at *A*. By setting a proportional divider to the ratio 2:1, and making the height of the rectangles two times the distances, *Aa*, *Bb*, *Cc*, etc., a smooth curve can be drawn which will average the triangular areas and make the rectangular areas and the strips contain the same areas. This curve is the derived curve.

The horizontal line is drawn to make the shaded area *C* equal to the shaded area *D* in Fig. 514, thus averaging the area under the curve.

In practice, a horizontal line at the proper height is all that is required to determine the rectangle.

Lay off *a'A'* (Fig. 513) equal to twice the length of *aA*. The proportional divider will do this if set at a ratio of 2:1. Then lay off *b'B'* equal to twice *bB* and so on. Draw the curve through the points so located. This curve is the derived curve.

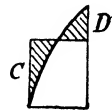

FIG. 514.

## CHAPTER XLIV

### APPLICATION OF DIFFERENTIATION

**919. Newton's Method of Approximation to the Roots of an Equation.**—We will demonstrate the method by means of an example.

Suppose that we have given the equation,

$$x^3 + 3x^2 - 2x - 14 = 0.$$

First, draw the graph by the synthetic method (Art. 237).

From the graph, the root is shown to be slightly larger than 2. Substitute  $x = 2$  in the equation and also in its first derivative.

$$y = 8 + 12 - 4 - 14 = +2.$$

$$\frac{dy}{dx} = 3x^2 + 6x - 2.$$

Substituting  $x = 2$ ,

$$\frac{dy}{dx} = 12 + 12 - 2 = 22 = \text{slope.}$$

Let  $\Delta x$  represent the small distance beyond 2 where the tangent to the curve at the point  $x = 2$  cuts the  $X$ -axis.

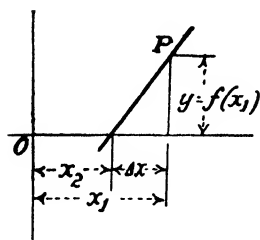

FIG. 515.

Assume that the graph at this point is a straight line, and the slope is then

$$\frac{2}{\Delta x} = 22.$$

$$\therefore \Delta x = \frac{2}{22} = .09.$$

The graph, then, crosses the  $X$ -axis at a point which is .09 unit beyond the point  $x = 2$ . Therefore,

$$x = 2.09 \text{ (approximately).}$$

If  $x_1$  is a first approximation to the root of  $f(x) = 0$ , then

$$[482] \quad x_2 = x_1 - \frac{f(x_1)}{f'(x_1)}$$

is, in general, a closer approximation. This process can be repeated any number of times.

The graph is first constructed and a first approximation  $x_1$  taken. If  $x_1$  is substituted in  $y = f(x)$ , then  $y = f(x_1)$ .

Let  $\Delta x$  represent the small distance beyond  $x = x_1$  where the tangent at  $P(x_1, y)$  cuts the X-axis.

Then the slope at  $x = x_1$  equals

$$f'(x_1) = \frac{f(x_1)}{\Delta x} \text{ approximately.}$$

$$\therefore \Delta x = \frac{f(x_1)}{f'(x_1)}.$$

But  $x_2 = x_1 - \Delta x$ . Then

$$x_2 = x_1 - \frac{f(x_1)}{f'(x_1)}. \quad [482]$$

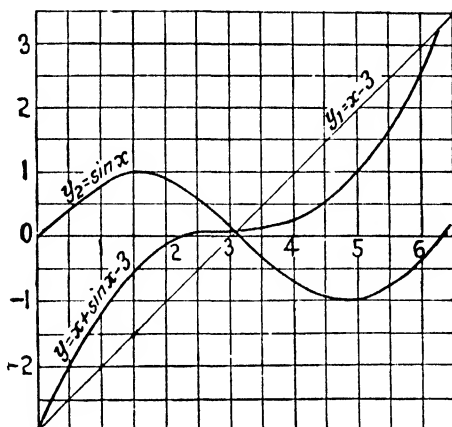

FIG. 516.

EXAMPLE.—Find the approximate root of  $x + \sin x - 3 = 0$ .

Let  $y_1 = x - 3$  and  $y_2 = \sin x$ . Then  $y = y_1 + y_2$ .

Draw the graphs of  $y_1 = x - 3$  and  $y_2 = \sin x$  ( $x$  in radians) and add the corresponding ordinates to get the graph of

$$y = x + \sin x - 3.$$

From the figure, the root is near  $x_1 = 2.2$ . Then

$$f(x_1) = 2.2 + \sin 2.2 - 3 = .009.$$

$$f'(x_1) = 1 + \cos 2.2 = 1 - .588 = .412.$$

$$x_2 = 2.2 - \frac{.009}{.412} = 2.2 - .022.$$

$$x_3 = 2.178 \text{ an approximate root.}$$

Newton's method is best adapted for equations which are not of the polynomial form, while Horner's method (Art. 273) is better adapted for polynomial equations.

**920. Speed and Velocity Defined.**—*Speed* will be used in these discussions to denote the *rate* of motion (or rate of change of space) regardless of direction.

*Velocity* will be used to denote the *speed* in a given direction and, consequently, is a vector quantity possessing direction as well as magnitude.

**921. Displacement.**—The change in position of a particle is called a *displacement*.

If  $A$  and  $B$  are two displacements of the same particle and if  $P_1$  is its initial position, then by drawing  $P_1P_2$  equal and parallel to  $A$  and from  $P_2$  drawing  $P_2P_3$  equal and parallel to  $B$ , a single displacement  $P_1P_3$  is found, which is equivalent to the two displacements  $A$  and  $B$ .

The resultant displacement can be represented by the diagonal of the parallelogram formed by using  $A$  and  $B$  for sides. It is shown in Fig. 517 as the closing side of a triangle whose sides are  $A$  and  $B$  with the arrowhead reversed to show that the direction is opposite to that used in drawing the closing side of the triangle.

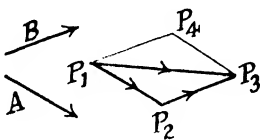

FIG. 517.

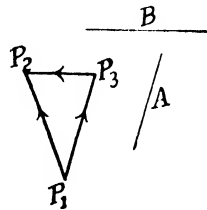

FIG. 518.

A displacement can be resolved into any number of component displacements. Thus, the displacement  $P_1P_2$  in Fig. 518 can be resolved into components parallel to  $A$  and  $B$ .

**922. Rectilinear or Straight-line Motion.**—Consider the motion of a particle  $P$  on a straight line  $AB$ .

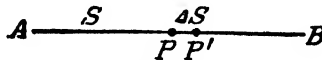

FIG. 519.

Let  $s$  be the distance measured from some fixed point, as  $A$ , to the point  $P$ , and let  $t$  be the time required for the particle to travel from  $A$  to  $P$ , or  $s$ . Since  $t$  is in nearly all cases considered as the independent variable, then for each value of  $t$  there corresponds a position of  $P$  and, therefore, a distance  $s$ . Hence,  $s$  will be a function of  $t$ , or

$$s = f(t).$$

Now let  $t$  take on an increment  $\Delta t$ , which results in  $s$  taking on the increment  $\Delta s$ . Then

$$\frac{\Delta s}{\Delta t} = \text{average velocity for the interval } \Delta t.$$

If  $P$  moves uniformly, this ratio is a constant and has the same value for any instant.

If  $P$  does not move uniformly, the instantaneous velocity, or rate of change of  $s$ , with respect to  $t$  at any instant is the limit of the ratio  $\frac{\Delta s}{\Delta t}$  as  $\Delta t$  approaches zero. That is,

$$v = \lim_{\Delta t \rightarrow 0} \frac{\Delta s}{\Delta t}.$$

[483] 
$$= \frac{ds}{dt},$$

The velocity is the first derivative of the distance with respect to the time.

From experiments, it was found that a body falling from rest in a vacuum near the earth's surface followed the law,

$$s = 16.1t^2,$$

where

$s$  = distance fallen in feet.

$t$  = time in seconds.

Give  $t$  an increment  $\Delta t$ . Then  $s$  takes on an increment  $\Delta s$ , and

$$\begin{aligned} s + \Delta s &= 16.1(t + \Delta t)^2 \\ &= 16.1t^2 + 32.2t\Delta t + 16.1\Delta t^2. \end{aligned}$$

Subtracting  $s = 16.1t^2$ ,

$$\Delta s = 32.2t\Delta t + 16.1\Delta t^2.$$

Dividing by  $\Delta t$ ,

$$\frac{\Delta s}{\Delta t} = 32.2t + 16.1\Delta t.$$

= average velocity throughout the interval  $\Delta t$ .

The instantaneous velocity for any time  $t$  is

$$\frac{ds}{dt} = 32.2t.$$

For instance, the instantaneous velocity at the end of 10 seconds is

$$\frac{ds}{dt} = 32.2(10) = 322 \text{ feet per second.}$$

**923. Acceleration in Rectilinear Motion.**—The rate of change of the velocity with respect to the time of a point moving along a straight line is defined as the *acceleration* and will be denoted by  $a$ . That is,

$$[484] \quad a = \frac{dv}{dt} = \frac{d\left(\frac{ds}{dt}\right)}{dt} = \frac{d^2s}{dt^2}.$$

**EXAMPLE.**—At the end of  $t$  seconds, the vertical height of a ball thrown upward with a velocity of 50 feet per second is

$$h = 50t - 16.1t^2.$$

$$v = \frac{dh}{dt} = 50 - 32.2t \text{ feet per second.}$$

$$a = \frac{d^2h}{dt^2} = -32.2 \text{ feet per second per second.}$$

Note that the velocity is decreasing as the ball travels upward and that the acceleration is negative.

The ball rises until its velocity becomes zero, or

$$\frac{dh}{dt} = 0.$$

Then

$$50 - 32.2t = 0.$$

$$t = \frac{50}{32.2} = 1.55 \text{ seconds.}$$

The ball continues to rise for 1.55 seconds after it is thrown.

To determine the height at which it starts to fall back, we find  $h$  when  $t = 1.55$ .

$$\begin{aligned} h &= 50t - 16.1t^2 \\ &= 77.5 - 24.96 = 52.54 \text{ feet.} \end{aligned}$$

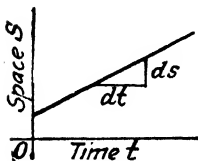

FIG. 520.

**924. Space-time Curves.**—The slope of the curve represents the velocity.

$$v = \frac{ds}{dt} = k.$$

= rate of change of  $s$  with respect to  $t$ .



The slope is constant. Therefore, the velocity is uniform.

If

$$v = \frac{ds}{dt} = \text{a variable.}$$

The slope varies, and, therefore, the velocity also varies (see Fig. 521).

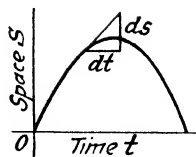

FIG. 521.

**925. Velocity-time Curves.**—The slope of the curve in Fig. 522 represents the acceleration or the rate of change of velocity with respect to the time.

$$a = \frac{dv}{dt} = \frac{d\left(\frac{ds}{dt}\right)}{dt} = \frac{d^2s}{dt^2}.$$

The slope is a constant. Therefore, the acceleration is constant.

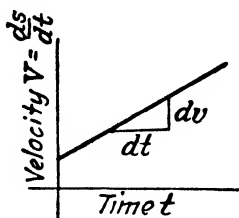

FIG. 522.

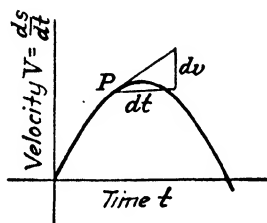

FIG. 523.

If  $\frac{d^2s}{dt^2}$  is a variable, the slope varies and, therefore, the acceleration also varies.

**926. Angular Velocity and Acceleration.**—Consider a particle rotating about the center  $O$  (Fig. 524).

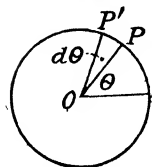

FIG. 524.

Let  $\theta$  be the angle through which the line  $OP$  rotates in the time  $t$  and  $\omega$  the angular velocity or the rate of change of  $\omega$  with respect to the time ( $\theta$  expressed in radians).

Then

$$[485] \quad \text{Angular velocity} = \omega = \frac{d\theta}{dt}.$$

The angular acceleration  $\alpha$ , or the rate of change of the angular velocity with respect to the time, is

$$[486] \quad \text{Angular acceleration} = \alpha = \frac{d\omega}{dt} = \frac{d\left(\frac{d\theta}{dt}\right)}{dt} = \frac{d^2\theta}{dt^2}.$$

In the case where we are given the number  $n$  of revolutions per minute instead of the angular velocity  $\omega$ , then

$$\omega = \frac{2\pi n}{60} \text{ radians per second.}$$

EXAMPLE.—A wheel starting from rest under the action of a constant moment (or twist) to rotate about its axis will turn in  $t$  seconds through the angle

$$\theta = kt^2$$

where  $k$  is a constant. Find its angular velocity and acceleration at time  $t$ .

$$\text{Velocity} = \omega = \frac{d\theta}{dt} = 2kt \text{ radians per second.}$$

$$\text{Acceleration} = \alpha = \frac{d\omega}{dt} = 2k \text{ radians per second per second.}$$

**927. Mean Velocity and Mean Speed.**—The mean velocity of a moving particle moving from  $P_1$  to  $P_2$  in a given time is the displacement chord  $P_1P_2$  divided by the number of units of time in the interval required for the particle to accomplish the motion.

As the interval of time is decreased, the displacement  $P_1P_2$  becomes smaller and smaller, and the direction of the mean velocity approaches the direction of the tangent at  $P_1$ , and we have the *instantaneous* velocity.

The mean speed of the particle is the length of the arc  $P_1P_2$  divided by the number of units in the time interval required.

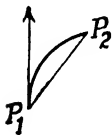

FIG. 525.

When a particle moves along a curve, its speed is the rate of change of distance along the curve with respect to the time  $t$ . The velocity of the particle at the point  $P$  is defined by a vector  $PT$  tangent to the path of the particle at  $P$ . It is a vector quantity because it has both magnitude and direction, and velocities should always be so represented. The speed of the particle cannot be represented by a vector since its direction is changing at every point. As the interval  $\Delta t$  approaches zero, the speed approaches the instantaneous speed of the particle at the point  $P$ .

The average speed for the interval  $\Delta t$  also approaches the instantaneous speed, for the instant  $t$ , as  $\Delta t$  approaches zero.

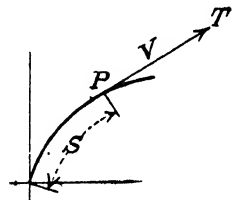

FIG. 526.

The vector which represents the instantaneous velocity of the particle at the point  $P$  and which is the tangent to the path at that point represents the distance and the direction that the particle would move in a unit of time if its motion continued unchanged throughout the unit.

EXAMPLE.—A wheel of radius  $r$  rotates at the rate of  $N$  revolutions per minute. Find the speed and velocity of a point on the rim (Fig. 527).

Let  $s$  = arc  $AP$  (from  $A$  to the moving point  $P$ ).

Then

$$s = r\theta,$$

where  $r$  = radius,  $\theta$  = angle of rotation in radians.

The speed of  $P$  is

$$\frac{ds}{dt} = r \frac{d\theta}{dt} = 2\pi rN \text{ feet per minute,}$$

since  $2\pi$  is the angle of one revolution and  $\frac{d\theta}{dt} = 2\pi N$  for  $N$  revolutions.

The velocity is also  $2\pi rN$  feet per minute in the direction of the tangent at the point  $P$ . The speed at any point is the same as that at any other point, but the velocities differ in their directions although they have the same numerical values.

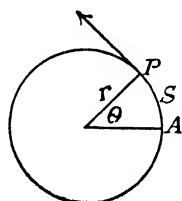

FIG. 527.

**928. Instantaneous Speed and Direction of Motion of a Particle.**

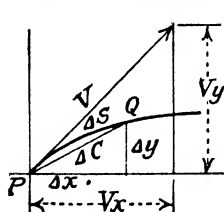

FIG. 528.

—Let  $\Delta s$  be the length of the arc  $PQ$  traveled over by a particle during a short interval of time  $\Delta t$  immediately following the instant under consideration.

Then the required speed  $v$  is the limit of the average speed  $\frac{\Delta s}{\Delta t}$ . Chord  $(\Delta c)^2 = (\Delta x)^2 +$

$$(\Delta y)^2,$$

or

$$\left(\frac{\Delta s}{\Delta t}\right)^2 \left(\frac{\Delta c}{\Delta s}\right)^2 = \left(\frac{\Delta x}{\Delta t}\right)^2 + \left(\frac{\Delta y}{\Delta t}\right)^2.$$

Let  $\Delta t$  approach zero. Then

$$\frac{\Delta s}{\Delta t} \text{ approaches } \frac{ds}{dt} = v.$$

$$\frac{\Delta x}{\Delta t} \text{ approaches } \frac{dx}{dt} = v_x.$$

$$\frac{\Delta y}{\Delta t} \text{ approaches } \frac{dy}{dt} = v_y.$$

$$\frac{\Delta c}{\Delta s} \text{ approaches } 1.$$

Substituting,

$$[487] \quad v = \sqrt{v_x^2 + v_y^2}.$$

The direction of motion is the direction of the tangent, or

$$[488] \quad \tan A = \frac{dy}{dx}.$$

Dividing numerator and denominator by  $dt$ ,

$$\tan A = \frac{\frac{dy}{dt}}{\frac{dx}{dt}} = \frac{v_y}{v_x} = \text{the direction of motion.}$$

EXAMPLE.—Consider  $x$  and  $y$  as functions of the time  $t$ . A bullet is fired in such a direction that it moves a horizontal distance in  $t$  seconds of

$$x = 500\sqrt{3}t$$

and a vertical distance of

$$y = 500t - 16.1t^2.$$

Find its instantaneous velocity at the end of 10 seconds.

$$\frac{dx}{dt} = 500\sqrt{3}.$$

$$\frac{dy}{dt} = 500 - 32.2t.$$

Substituting  $t = 10$ ,

$$\frac{dy}{dt} = 500 - 32.2 \times 10 = 178.$$

$$\frac{ds}{dt} = \sqrt{(500\sqrt{3})^2 + (178)^2} = 884 \text{ feet per second.}$$

EXAMPLE.—Consider the equations of the motion of a projectile, as

$$x = 1000t \text{ and } y = 500t - 16t^2.$$

The rate at which the height of the projectile  $h$  is increasing at any time  $t$  is the rate at which the projectile is rising; that is,

$$\text{Vertical speed} = \frac{dy}{dt} = 500 - 32t.$$

Thus at the instant  $t = 10$  the projectile will be rising at the rate of  $500 - 320 = 180$  feet per second.

Similarly, since

$$\frac{dx}{dt} = 1000,$$

the projectile will be moving at the rate of 1000 feet per second in a horizontal direction.

If we draw directed lines, or *vectors*, to represent to some scale the motion or the component velocities, then the actual velocity, both its magnitude and direction, will be presented by the diagonal of the rectangle.

Therefore,

$$v = \sqrt{(1000)^2 + (180)^2} = 1016.$$

$$\tan A = \frac{180}{1000} = .18.$$

$$A = 10^\circ 12'$$

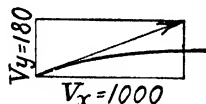

FIG. 529.

Thus at the instant  $t = 10$  the projectile was moving with a speed of 1016 feet per second in a direction making an angle of  $10^\circ 12'$  with the horizontal.

### 929. Relation of Angular Speed of Rotation and Linear Speed in a Circular Path of a Particle.

From Fig. 530,



FIG. 530.

whence

$$\Delta s = r\Delta\theta,$$

$$\frac{\Delta s}{\Delta t} = r\frac{\Delta\theta}{\Delta t}.$$

Then, as  $\Delta t$  approaches zero,

$$[488a] \quad \frac{ds}{dt} = r\frac{d\theta}{dt}.$$

*The speed of any point on a body rotating about a fixed axis is the product of the distance of the point from the axis and the angular speed of the body.*

A similar law holds for tangential acceleration.

$$v = r\omega.$$

$$[489] \quad \frac{dv}{dt} = r\frac{d\omega}{dt}.$$

*The tangential acceleration of a point on a body rotating about a fixed axis is the angular acceleration about the fixed axis multiplied by the distance of the point from the axis.*

**930. Curvilinear Motion in a Plane.**—It will be recalled from the definitions that the speed of a particle is the rate of motion in a path irrespective of the direction and that the velocity is the rate of motion in a certain direction.

Assume that a particle moves along a curved path from  $P_1$  to  $P_2$  in an interval of time  $\Delta t$  and that the velocities at  $P_1$  and  $P_2$  are  $v$  and  $v + \Delta v$ , respectively. The directions of the velocities at these points are the directions of the tangents to the curve at these points. This follows since the particle would continue to move along a tangent to the curve if it were not impelled by some other force to

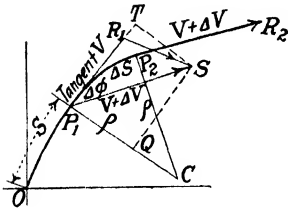

FIG. 531.

follow the curve. If  $\Delta s$  represents the space traveled at  $\Delta t$  time, then

$\frac{\Delta s}{\Delta t}$  represents the average speed for interval  $\Delta t$ .

Draw  $P_1S = P_2R_2 = v + \Delta v$ .

$R_1S$  represents the change in velocity during the interval  $\Delta t$ , and  $\frac{R_1S}{\Delta t}$  gives the average, or mean rate of change or acceleration. Since both velocity and acceleration are vector quantities, the resolution of the vector  $R_1S$  can be made in any direction, but for convenience its components are taken in directions normal to and tangent to the curve. The change from the velocity  $v$  to the velocity  $v + \Delta v$  is indicated by the vector  $R_1S$  from  $R_1$  to  $S$ .

Draw the normals  $P_1C$  and  $P_2C$  and project  $R_1S$  on the tangent and normal at  $P_1$ . The projection of  $R_1S$  on the tangent line is  $R_1T$  and the projection of the vector  $R_1S$  on the normal is  $P_1Q$ . The interval of time considered is  $\Delta t$ .

Now,

$$P_1Q = TS = P_1S \sin \Delta\phi,$$

or,

$$\text{Normal component} = \lim_{\Delta t \rightarrow 0} \left[ \frac{P_1Q}{\Delta t} \right] = \lim_{\Delta t \rightarrow 0} \left[ \frac{P_1S \sin \Delta\phi}{\Delta t} \right].$$

Substitute  $v + \Delta v$  for  $P_1S$  and multiply and divide by both  $\Delta\phi$  and  $\Delta s$  which does not change the value of the expression. Then

$$\text{Normal component} = \lim_{\Delta t \rightarrow 0} \left[ (v + \Delta v) \frac{\sin \Delta\phi}{\Delta\phi} \cdot \frac{\Delta\phi}{\Delta s} \cdot \frac{\Delta s}{\Delta t} \right].$$

As  $\Delta t$  becomes smaller and smaller, or approaches zero, then  $v + \Delta v$  approaches  $v$ .

$\frac{\sin \Delta\varphi}{\Delta\varphi}$  approaches 1 (Art. 936).

$\frac{\Delta\varphi}{\Delta s}$  approaches  $\frac{1}{\rho}$  (Art. 975),

and

$\frac{\Delta s}{\Delta t}$  approaches  $\frac{ds}{dt} = v$ .

Then

[490] Normal component =  $v \cdot 1 \cdot \frac{1}{\rho} \cdot v = \frac{v^2}{\rho}$ ,

where  $\rho$  is the radius of curvature of the curve at  $P_1$ .

If the path is a circle, then  $\rho = r$  and

[491] Normal acceleration for circular path is  $\frac{v^2}{r}$ .

If the *speed* is uniform, then the tangential acceleration is zero but the normal acceleration is still  $\frac{v^2}{r}$  and in a direction towards the center.

The tangential acceleration is

$$\text{Limit}_{\Delta t \rightarrow 0} \left[ \frac{R_1 T'}{\Delta t} \right].$$

$$R_1 T' = P_1 T - P_1 R_1.$$

But  $P_1 T = P_1 S \cos \Delta\varphi = (v + \Delta v) \cos \Delta\varphi$ , and  $P_1 R_1 = v$ .  
Then

$$\begin{aligned} \text{Tangential acceleration} &= \text{Limit}_{\Delta t \rightarrow 0} \left[ \frac{(v + \Delta v) \cos \Delta\varphi - v}{\Delta t} \right]. \\ &= \text{Limit}_{\Delta t \rightarrow 0} \left[ \frac{(\cos \Delta\varphi - 1)v + \Delta v \cos \Delta\varphi}{\Delta t} \right]. \end{aligned}$$

But  $\cos \Delta\varphi - 1 = -2 \sin^2 \frac{1}{2} \Delta\varphi$ .

Therefore,

$$\text{Tangential acceleration} = \text{Limit}_{\Delta t \rightarrow 0} \left[ -\frac{2v \sin^2 \frac{1}{2} \Delta\varphi}{\Delta t} + \frac{\Delta v}{\Delta t} \cos \Delta\varphi \right].$$

Multiplying and dividing the first member by  $\Delta\varphi$ , and rearranging,

Tangential acceleration =

$$\lim_{\Delta t \rightarrow 0} \left[ -\frac{\sin \frac{1}{2}\Delta\varphi}{\frac{1}{2}\Delta\varphi} v \cdot \sin \frac{1}{2}\Delta\varphi \frac{\Delta\varphi}{\Delta t} + \frac{\Delta v}{\Delta t} \cos \Delta\varphi \right].$$

$\frac{\sin \frac{1}{2}\Delta\varphi}{\frac{1}{2}\Delta\varphi}$  approaches 1 (Art. 936).  
 $\sin \frac{1}{2}\Delta\varphi$  approaches 0.  
 $\cos \Delta\varphi$  approaches 1.

Therefore,

$$[492] \quad \text{Tangential acceleration} = -1 \cdot 0 \cdot \frac{dv}{dt} + \frac{dv}{dt} \\ = \frac{dv}{dt} = \frac{d^2s}{dt^2}.$$

From principles of effective force, a weight  $W$  which moves in a curved path has at any instant,

$$\text{Tangential acceleration} = \frac{dv}{dt} \\ \text{Normal acceleration} = \frac{v^2}{\rho}.$$

The effective force  $\frac{W}{g}a$  must be the resultant of the two components, or

$$\text{Tangential force} = \frac{W}{g} \cdot \frac{dv}{dt} \\ \text{Normal force} = \frac{W}{g} \cdot \frac{v^2}{\rho}.$$

[493] The resultant acceleration, therefore, equals

$$\sqrt{(\text{Normal acceleration})^2 + (\text{Tangential acceleration})^2},$$

or

$$\text{Resultant acceleration} = \sqrt{\frac{v^4}{\rho^2} + \left(\frac{dv}{dt}\right)^2},$$

and has a direction

$$[494] \quad \theta = \tan^{-1} \frac{v^2}{\rho \frac{dv}{dt}},$$

where  $\theta$  is the angle between the tangent to the curve at  $P_1$  and the direction of the resultant acceleration.



## MISCELLANEOUS PROBLEMS

**931. PROBLEM.**—The edge of a metal cube is expanding at the rate of .04 inch per hour due to an increase in the temperature.

How fast is the volume increasing per hour if  $x$  is the edge of the cube and  $V$  the volume?

We have the relation,

$$V = x^3.$$

But  $x$  and, consequently,  $V$  are functions of another variable, time, which we will call  $t$  (in hours).

Then

$$\frac{dV}{dt} = \frac{dV}{dx} \cdot \frac{dx}{dt} \quad [469]$$

From  $V = x^3$ ,

$$\frac{dV}{dx} = 3x^2.$$

We also know that the rate of change of  $x$  with respect to  $t$  is .04 inch per hour, or

$$\frac{dx}{dt} = .04.$$

Substituting these values,

$$\frac{dV}{dt} = 3x^2 \times .04 = .12x^2.$$

Now if we desire to know at what rate the volume is changing when  $x$  has any definite value, we need only substitute that value in the above expression. Thus, when  $x = 10$ ,

$$\frac{dV}{dt} = .12(10)^2 = 12 \text{ cubic inches per hour.}$$

**932. PROBLEM.**—One end of a 20-foot ladder rests on the ground, 12 feet from the foundation of a building. The other end rests against the side of the building. If the end on the ground is carried away from the building on a line perpendicular to it at a uniform rate of 4 feet per second, find the law of motion of the other end.

*First Method.*—Consider the height of the end as a function of the horizontal distance of the foot of the ladder from the side of the building and this latter distance as itself a function of the time. This involves the determination of a function of a function.

From the right triangle formed,

$$x^2 + y^2 = 20^2. \quad (1)$$

From the statement of the problem, the distance of the foot of the ladder from the building is a function of the time, thus,

$$x = 12 + 4t. \quad (2)$$

Differentiating (1), we have

$$2x + 2y \frac{dy}{dx} = 0,$$

or the rate of change of  $y$  with respect to  $x$  is

$$\frac{dy}{dx} = -\frac{x}{y} = -\frac{x}{\sqrt{400 - x^2}}.$$

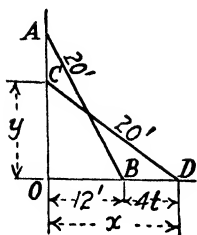

FIG. 532.

From (2) we find the rate at which  $x$  changes with respect to the time  $t$ , or

$$\frac{dx}{dt} = 4.$$

Since

$$\frac{dy}{dt} = \frac{dy}{dx} \cdot \frac{dx}{dt}, \quad [469]$$

we have

$$\frac{dy}{dt} = -\frac{x}{\sqrt{400 - x^2}} \times 4 = -\frac{4x}{\sqrt{400 - x^2}}. \quad (3)$$

Now assume that we desire to know at what rate the top of the ladder is moving when  $t = 1$  second.

Substituting in (2),

$$x = 12 + 4(1) = 16.$$

Substituting in (3),

$$\frac{dy}{dt} = -\frac{4 \times 16}{\sqrt{400 - 256}} = -\frac{64}{12} = -5\frac{1}{3} \text{ feet per second.}$$

The minus sign indicates that the height  $y$  is decreasing at the rate of  $5\frac{1}{3}$  feet per second.

It will have been observed that in this problem we have a geometric relation which allows the relation between  $x$  and  $y$  to be expressed implicitly by the equation,

$$x^2 + y^2 = (20)^2.$$

Also from the conditions of the problem we can express  $x$  as an explicit function of a third variable  $t$  and find the derivative of  $y$  with respect to  $t$  by using the formula for finding the derivative of a function of a function.

*Second Method.*—Writing the height  $y$  as a function of the horizontal distance expressed in terms of the time  $t$ , then we simply have a function  $y$  expressed in terms of an independent variable,  $t$ , or

$$\begin{aligned} y &= \sqrt{400 - (12 + 4t)^2}. \\ &= 4\sqrt{16 - 6t - t^2}. \\ &= 4(16 - 6t - t^2)^{\frac{1}{2}}. \end{aligned}$$

$$\begin{aligned} \frac{dy}{dt} &= 4 \times \frac{1}{2} (16 - 6t - t^2)^{-\frac{1}{2}} \cdot \frac{d(16 - 6t - t^2)}{dt} \\ &= \frac{2(-6 - 2t)}{\sqrt{16 - 6t - t^2}} = \frac{-12 - 4t}{\sqrt{16 - 6t - t^2}} \end{aligned}$$

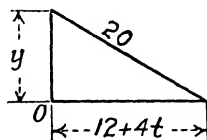

FIG. 533.

If  $t = 1$  as before,

$$\frac{dy}{dt} = \frac{-12 - 4}{\sqrt{16 - 6 - 1}} = -\frac{16}{3} = -5\frac{1}{3} \text{ feet per second.}$$

If the problem had been to find a formula for the motion of the top of the ladder with respect to the starting point A, then the equation for the motion would have been

$$y = 16 - 4\sqrt{16 - 6t - t^2}.$$

The proof of this is left as an exercise.

In this second method, the geometric and time relations were combined into one equation simply by the substitution of the independent variable for the distance  $x$  according to the equation which expresses the relation between them.

Putting it in another way, if  $y$  is expressed in terms of  $x$  and if  $x$  is expressed in terms of  $t$ , then  $y$  may be expressed directly in terms of  $t$ . As an instance, consider

$$y = x^5 \text{ and } x = t^2.$$

Then

$$y = t^{10}$$

We can differentiate this as a function of a function.

$$\frac{dy}{dx} = 5x^4 \text{ and } \frac{dx}{dt} = 2t.$$

$$\frac{dy}{dt} = \frac{dy}{dx} \cdot \frac{dx}{dt} = 5x^4 \times 2t = 5t^8 \times 2t = 10t^9, \text{ [469]}$$

or we may differentiate  $y$  with respect to the independent variable directly.

$$y = t^{10}.$$

$$\frac{dy}{dt} = 10t^9.$$

It is often not convenient to use the latter method and in certain instances, the first method, while longer, is the safer of the two.

**933. PROBLEM.**—Water is flowing at a uniform rate of 10 cubic inches per minute into a right circular cone whose semivertical angle is  $45^\circ$ , whose vertex is down, and whose axis is vertical.

At what rate is the surface of the water in the cone rising and at what rate is the area of this surface increasing?

Compute the rates of increase when the water is 25 inches deep.

$$\begin{aligned}\text{Volume} &= \frac{1}{3}h \cdot \pi h^2. \\ &= \frac{1}{3}\pi h^3.\end{aligned}$$

$$\frac{dV}{dh} = \pi h^2 =$$

the rate of change of the volume with respect to the height.

From the statement of the problem,

$$\frac{dV}{dt} = 10 \text{ cubic inches per minute.}$$

But

$$\frac{dV}{dt} = \frac{dV}{dh} \cdot \frac{dh}{dt}, \text{ or } 10 = \pi h^2 \frac{dh}{dt}, \quad [469]$$

whence

$$\frac{dh}{dt} = \frac{10}{\pi h^2}.$$

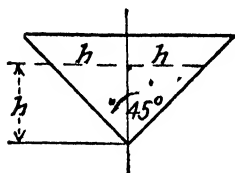

FIG. 534.

When  $h = 25$ ,

$$\frac{dh}{dt} = \frac{10}{\pi \cdot 625} = .0051 \text{ inch per minute.}$$

This is the rate at which the height of the water is rising when the height is 25 inches.

To determine the rate at which the area of the surface is increasing, we consider the expression for the area,

$$A = \pi h^2.$$

Differentiating,

$$\frac{dA}{dh} = 2\pi h = \text{rate of change of area with respect to the height } h.$$

The rate of change of the area with respect to the time is

$$\frac{dA}{dt}, \text{ but } \frac{dA}{dt} = \frac{dA}{dh} \cdot \frac{dh}{dt}. \quad [469]$$

NOTE.—From the first part of the problem,

$$\frac{dh}{dt} = \frac{10}{\pi h^2}.$$

Therefore,

$$\frac{dA}{dt} = 2\pi h \times \frac{10}{\pi h^2} = \frac{20}{h}.$$

When the height  $h = 25$ ,

$$\frac{dA}{dt} = \frac{20}{25} = .8 \text{ square inch per minute.}$$

This is the rate at which the area of the surface is increasing when the height of the water is 25 inches.

**934. PROBLEM.**—A ship  $A$  sailing eastward at the rate of 12 miles per hour left a certain point 5 hours before another ship  $B$  arrived at the point from the north traveling at the rate of 16 miles per hour. How fast was the distance between the ships changing 2 hours after  $A$  left the point?

Let  $x$  equal the distance from  $A$  to the point and  $y$  the distance from  $B$  to the point. Also let  $z$  be the distance between the two ships. From Fig. 535,

$$z^2 = x^2 + y^2.$$

Differentiating with respect to the time,

$$2z \frac{dz}{dt} = 2x \frac{dx}{dt} + 2y \frac{dy}{dt}.$$

Or

$$z \frac{dz}{dt} = x \frac{dx}{dt} + y \frac{dy}{dt}. \quad (1)$$

But  $x = 12t$ .

$$\therefore \frac{dx}{dt} = 12,$$

and  $y = 80 - 16t$ ; whence  $\frac{dy}{dt} = -16$ .

At the instant when  $t = 2$  (2 hours after  $A$  left),

$$x = 12 \times 2 = 24.$$

$$y = 80 - (16)2 = 48.$$

$$z = \sqrt{(24)^2 + (48)^2} = \sqrt{2880} = 53.66.$$

Substituting these values in (1),

$$53.66 \frac{dz}{dt} = 24 \times 12 + 48 \times (-16) = -480.$$

$$\frac{dz}{dt} = \frac{-480}{53.66} = -8.95 \text{ miles per hour.}$$

From this we see that the distance between the ships is decreasing at the rate of 8.95 miles per hour at the instant 2 hours after  $A$  has left the point.

**935. Force, Mass, and Acceleration.**—Sir Isaac Newton showed that accelerations in bodies were directly proportional to the forces acting and inversely proportional to the masses

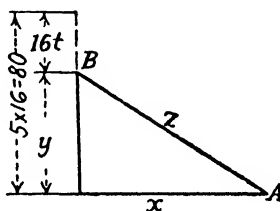

FIG. 535.

acted upon. This law is known as Newton's second law of motion and is expressed in mathematical symbols, thus,

$$[495] \quad a \propto \frac{F}{m}, \text{ or } a = k \frac{F}{m}.$$

Our unit of force is the pound and our unit of acceleration is 1 foot per second per second, sometimes written,

$$\text{ft./sec.}^2$$

When a force of 1 pound acts upon a mass of 1 pound, the acceleration produced by the force is 32.2 feet per second per second. This is true whether the case is that of a falling body or another case in which all other forces can be neglected excepting that producing the acceleration. As an example, consider a 1-pound mass sliding on a table and so arranged that a counter-weight just neutralizes the friction of sliding. If a force of 1 pound is horizontally applied, it will give the weight an acceleration of 32.2 feet per second for every second that it is allowed to act. In other words, the increase in the velocity per second is 32.2 feet per second. This increase in velocity per second is independent of the length of time that the force acts and is independent of the initial state of rest or motion of the mass.

For convenience, the unit of mass is taken to make the proportionality factor  $k$  equal to 1. If, then, a unit force of 1 pound acts on a weight of 32.2 pounds instead of on a mass of 1 pound, the acceleration would be 1 foot per second per second. Hence, to make  $k = 1$ , the unit of mass is taken as 32.2 pounds, or

$$\text{Mass} = \frac{\text{Weight}}{32.2}.$$

The unit of mass (32.2 pounds) is denoted by  $g$  and the weight by  $W$ . Then

$$\text{Mass } (M) = \frac{W}{g},$$

or

$$a = \frac{F}{M} = \frac{F}{\frac{W}{g}} = \frac{Fg}{W},$$

or

$$F = Ma = \frac{Wa}{g}.$$

A force acting on a body in space produces a motion of the body in the direction in which the force acts.

Force and acceleration are vector quantities having both magnitude and direction, while mass is a scalar quantity or a magnitude only without direction.

From Art. 923,

$$\text{Acceleration} = \frac{dv}{dt} = \frac{d^2s}{dt^2}.$$

Then

$$[496] \quad F = M \frac{dv}{dt} = \frac{W}{g} \cdot \frac{dv}{dt} = M \frac{d^2s}{dt^2} = \frac{W}{g} \cdot \frac{d^2s}{dt^2}.$$

If  $F$  is resolved into two components  $F_1$  and  $F_2$  and if  $a_1$  and  $a_2$  are the corresponding components of acceleration, then

$$F_1 = Ma_1 \text{ and } F_2 = Ma_2.$$

Then  $x$  and  $y$  components are

$$F_x = Ma_x \text{ and } F_y = Ma_y.$$

## CHAPTER XLV

### DIFFERENTIATION OF TRIGONOMETRIC FUNCTIONS

**936. Derivative of  $y = \sin u$ .**—Consider the function,

$$y = \sin u,$$

where  $u$  is some function of  $x$ .

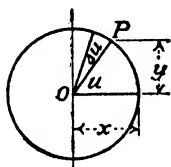

FIG. 536.

Let  $x_0$  be some definite value of  $x$  and let  $u_0$  and  $y_0$  be the corresponding values of  $u$  and  $y$ . Then

$$y_0 = \sin u_0.$$

Now let  $x = x_0 + \Delta x$ . Then

$$y_0 + \Delta y = \sin(u_0 + \Delta u).$$

Subtracting  $y_0 = \sin u_0$ ,

$$\Delta y = \sin(u_0 + \Delta u) - \sin u_0.$$

From trigonometry, the difference of the sines of two different angles is

$$\sin A - \sin B = 2 \cos \frac{1}{2}(A + B) \sin \frac{1}{2}(A - B). \quad [283]$$

Let

$$A = u_0 + \Delta u, \quad B = u_0,$$

whence

$$\Delta y = \sin(u_0 + \Delta u) - \sin u_0 = 2 \cos \frac{1}{2}(2u_0 + \Delta u) \sin \frac{1}{2}\Delta u.$$

$$\Delta y = 2 \cos \left( u_0 + \frac{\Delta u}{2} \right) \sin \frac{1}{2}\Delta u.$$

Dividing by  $\Delta u$ ,

$$\frac{\Delta y}{\Delta u} = 2 \cos \left( u_0 + \frac{\Delta u}{2} \right) \frac{\sin \frac{1}{2}\Delta u}{\Delta u}.$$

Since

$$\frac{\Delta y}{\Delta x} = \frac{\Delta y}{\Delta u} \cdot \frac{\Delta u}{\Delta x}, \quad [469]$$

we have

$$\begin{aligned} \frac{\Delta y}{\Delta x} &= 2 \cos \left( u_0 + \frac{\Delta u}{2} \right) \frac{\sin \frac{1}{2}\Delta u}{\Delta u} \cdot \frac{\Delta u}{\Delta x} \\ &= \cos \left( u_0 + \frac{\Delta u}{2} \right) \frac{\sin \frac{1}{2}\Delta u}{\frac{1}{2}\Delta u} \cdot \frac{\Delta u}{\Delta x}. \end{aligned}$$

As  $\Delta x$  approaches zero,

$$\frac{dy}{dx} = \cos u_0 \frac{du}{dx} \times \lim_{\Delta x \rightarrow 0} \left[ \frac{\sin \frac{1}{2}\Delta u}{\frac{1}{2}\Delta u} \right].$$



It will be seen that it is necessary to find the limit of

$$\frac{\sin \frac{1}{2} \Delta u}{\frac{1}{2} \Delta u}$$

As  $\Delta x$  approaches zero,  $\Delta u$  also approaches zero.

Let us examine a small angle and determine what happens to the ratio of the sine of the angle and the angle as the angle approaches zero, or let us determine

$$\lim_{\theta \rightarrow 0} \left[ \frac{\sin \theta}{\theta} \right].$$

Let  $AT$  be the tangent to the circle at  $A$  and let  $BC$  be perpendicular to  $OA$ . The area of the triangle  $OCB$  is less than the area of the sector  $OAB$  and  $OAB$  is less in area than the triangle  $OAT$ . Or

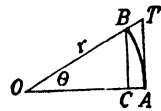

FIG. 537.

$$\frac{1}{2}(BC)(OC) < \frac{1}{2}\theta r^2 < \frac{1}{2}(AT)r.$$

$$\frac{BC}{r} \cdot \frac{OC}{r} < \theta < \frac{AT}{r}, \text{ or } \frac{OC}{r} \sin \theta < \theta < \tan \theta.$$

$$\frac{OC}{r} < \frac{\theta}{\sin \theta} < \frac{1}{\cos \theta}.$$

As  $\theta$  approaches zero,

$$OC \text{ approaches } r \text{ and } \frac{OC}{r} \text{ approaches } 1.$$

$$\cos \theta \text{ approaches } 1 \text{ and } \frac{1}{\cos \theta} \text{ approaches } 1.$$

Since the first and third members of the inequality approach 1, then

$$\frac{\theta}{\sin \theta} \text{ approaches } 1.$$

and, therefore,

$$\frac{\sin \theta}{\theta} \text{ approaches } 1.$$

Hence, when  $\Delta u$  approaches 0,  $\frac{\sin \frac{1}{2} \Delta u}{\frac{1}{2} \Delta u}$  approaches 1, and therefore

$$[497] \quad \frac{dy}{dx} = \cos u \cdot \frac{du}{dx}, \text{ or } \frac{d(\sin u)}{dx} = \cos u \cdot \frac{du}{dx}$$

If  $u = x$ , then

$$[498] \quad \frac{d(\sin x)}{dx} = \cos x \cdot \frac{dx}{dx} = \cos x.$$

Further, if  $y = \sin (Bx + C)$  where  $B$  and  $C$  are constants, then

$$[499] \quad \frac{d[\sin(Bx + C)]}{dx} = B \cos (Bx + C) \cdot \frac{dx}{dx} = B \cos (Bx + C).$$

Likewise,

$$[500] \quad \frac{d[A \sin (Bx + C)]}{dx} = AB \cos (Bx + C).$$

EXAMPLE.—Differentiate with respect to  $x$ ,

$$y = 5 \sin^2 x.$$

Let  $u = \sin x$ , then

$$y = 5u^2 \text{ and } \frac{dy}{du} = 10u.$$

$$\frac{dy}{dx} = \frac{dy}{du} \cdot \frac{du}{dx} \text{ and } \frac{du}{dx} = \cos x.$$

But  $u = \sin x$ .

Substituting these values,

$$\frac{d[5 \sin^2 x]}{dx} = 10 \sin x \cdot \cos x = 5[2 \sin x \cdot \cos x].$$

From trigonometry,

$$2 \sin x \cdot \cos x = \sin 2x \quad [290]$$

Hence,

$$\frac{d[5 \sin^2 x]}{dx} = 5 \sin 2x.$$

**937. Derivative of  $y = \cos u$ .**—From trigonometry,

$$\cos u = \sin \left( \frac{\pi}{2} - u \right) \text{ (Art. 603).}$$

Therefore,

$$\begin{aligned} \frac{dy}{dx} &= \frac{d\left[\sin\left(\frac{\pi}{2} - u\right)\right]}{dx} = \cos\left(\frac{\pi}{2} - u\right) \frac{d\left(\frac{\pi}{2} - u\right)}{dx} \\ &= -\cos\left(\frac{\pi}{2} - u\right) \frac{du}{dx}. \end{aligned}$$

From trigonometry,

$$\cos\left(\frac{\pi}{2} - u\right) = \sin u.$$

Therefore,

$$[501] \quad \frac{d(\cos u)}{dx} = -\sin u \cdot \frac{du}{dx}$$

Further, if  $u = x$ , or  $y = \cos x$ ,

$$[502] \quad \frac{dy}{dx} = \frac{d(\cos x)}{dx} = -\sin x,$$

and if  $y = \cos [Bx + C]$  where  $B$  and  $C$  are constants, then

$$[503] \quad \frac{d[\cos (Bx + C)]}{dx} = -B \sin (Bx + C).$$

Likewise, if  $y = A \cos [Bx + C]$ ,

$$[504] \quad \frac{dy}{dx} = \frac{d[A \cos (Bx + C)]}{dx} = -AB \sin (Bx + C).$$

**938. The derivative of  $y = \text{vers } u$**  will be given but will not be developed, since this function is seldom used.

$$[505] \quad \frac{d(\text{vers } u)}{dx} = \sin u \cdot \frac{du}{dx}.$$

**939. Graphical Differentiation of  $y = \sin x$ .**—If the derived curve of the sine curve is carefully drawn according to Art. 916, a curve will result which is the same as the sine curve except that it is shifted one-half a wave, or

$$\frac{\pi}{2} = \frac{3.1416}{2} = 1.57 \text{ units to the left.}$$

This curve is, of course, the cosine curve as was shown by the analysis of Arts. 622 and 623.

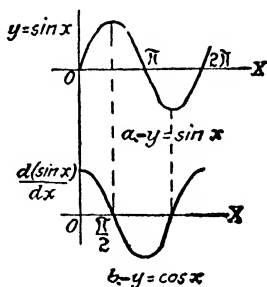

FIG. 538.

**940. Graphical Differentiation of  $y = \cos x$ .**—The derived curve of  $y = \cos x$  resembles the derived curve of  $y = \sin x$  except that it is also shifted one-half a wave to the left. This means that the curve is the same as the graph of  $y = \sin x$  except that it is shifted one wave to the left or a distance of

3.1416 units. This makes the curve a minus sine curve or a graph of  $y = -\sin x$ .

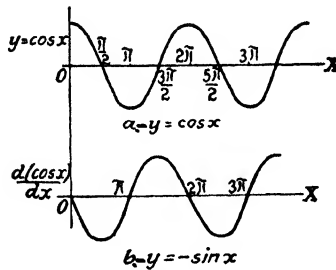

FIG. 539.

To find the successive derived curves of  $y = \sin x$ , or  $y = \cos x$ , simply move the origin to the right through a distance of  $\frac{1}{2}\pi$  or 1.57 units for each successive differentiation.

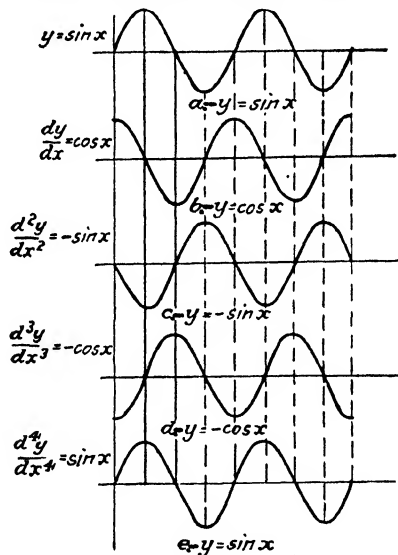

FIG. 540.

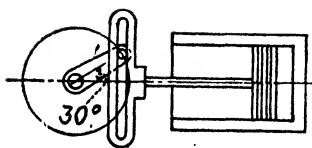

FIG. 541.

**941. The Crank and Slot Mechanism.**—If we consider a steam engine with a slot mechanism similar to that shown in Fig. 541, we can apply the cosine law. For the initial curve,  $y = a \cos \omega t$ .

**EXAMPLE.**—Assume that a 12-inch (1 foot) crank rotates 60 revolutions per minute. What is the piston velocity when the crank has turned through an angle of  $30^\circ$  from the center? What is the acceleration of the piston at this point?

*Analytical Method.*

$$\omega = 2\pi \text{ (since one revolution } (2\pi) \text{ is made per second).}$$

$$a = 1 \text{ (reducing crank length to feet).}$$

Then

$$y = \cos 2\pi t.$$

$$\frac{dy}{dt} = -2\pi \sin 2\pi t = \text{velocity of piston.}$$

$$\frac{d^2y}{dt^2} = -4\pi^2 \cos 2\pi t = \text{acceleration of piston.}$$

Since the crank rotates through  $360^\circ$  in 1 second, and  $30^\circ = \frac{1}{12}$  revolution

$$t = \frac{1}{12} \text{ second.}$$

$$\frac{dy}{dt} = -2\pi \sin 2 \cdot \frac{1}{12} \cdot \pi = -2\pi \sin \frac{\pi}{6} = 3.14 \text{ feet per second.}$$

= velocity.

$$\frac{d^2y}{dt^2} = -4\pi^2 \cos 2\pi \cdot \frac{1}{12} = -4\pi^2 \cos \frac{\pi}{6} = 39.47 \times .886.$$

$$= 34.18 \text{ feet per second per second} = \text{acceleration of piston.}$$

**942. Graphical Solution of Last Problem.**—Draw the cosine curve to any convenient horizontal and vertical scale and plot the time as abscissae. Since the crank rotates through one complete revolution in 1 second, our period is 1 second. Divide the period into any number of divisions, as 12.

The crank travels one circumference ( $2 \times 3.1416$ ) in 1 second, or 6.28 feet. The ratio of distance to time is, therefore, 6.28 to 1.

The first derivative of the distance with respect to the time gives the velocity and we, therefore, differentiate the curve graphically to get values for the velocity. From Art. 940 the shifting of the origin to the right a distance equal to  $\frac{1}{2}\pi$  is equivalent to differentiating the original curve, but a new vertical or ordinate scale must be determined. As the second curve is identical with the first except that in the second the origin has been translated and the scale of ordinates changed because the function has been multiplied by  $2\pi$ , or 6.28, the vertical scale for the derived curve will be taken so that the values of the derived

function are in the ratio of 6.28:1 to the values of the primary function. In other words, a unit distance represents 1 unit in the primary function graph and 6.28 units in the graph of the derived function. Thus the maximum value which the primary function reaches is 1, whereas the maximum value of the derived function is 6.28 units.

For the acceleration curve, or second derived curve, the same curve is again used but translated again to the left a distance equal to  $\frac{1}{2}\pi$  and the vertical or ordinate scale is changed again so that the values of the second derived function are 6.28 times the corresponding values of the first derived function. This will be readily seen upon reference to Fig. 542 where the primary and first and second derived curves are shown. It will be seen that the height of the loop in the second derived curve is  $6.28 \times 6.28 = 39.47$  units, which means that a given distance measured vertically represents 39.47 times the value in the second derived graph that it does in the primary graph.

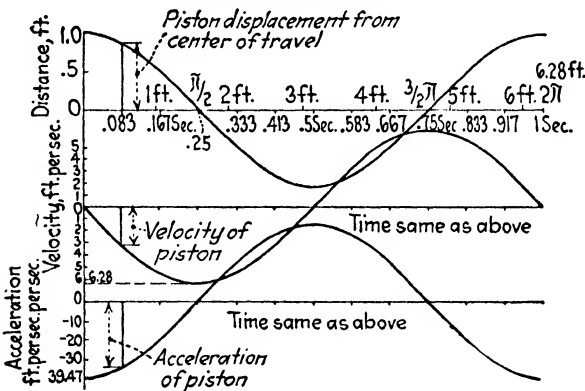

FIG. 542.

Acceleration is an important consideration in the study of the inertia of moving parts, and this example illustrates a method of determining this acceleration.

**943. Simple Harmonic Motion (S.H.M.).**—If a point  $P$  moves in a circle with a constant angular velocity of  $\omega$  radians per second, or  $\omega t$  radians for  $t$  seconds, its projection  $Q$  upon any diameter will oscillate back and forth in a manner that is called *simple harmonic motion*.

Let  $x$  equal the distance from the center of rotation to the projection. Then

$$x = r \cos \omega t$$

If the value of the angle is  $C$  at the time when  $t = 0$ , then

$$x = r \cos (\omega t + C).$$

This is the general formula for simple harmonic motion in terms of the displacement from the center.

If we differentiate, then

[506]  $\frac{dx}{dt} = -\omega r \sin (\omega t + C) = \text{speed of } Q.$

Differentiating again,

[507]  $\frac{d^2x}{dt^2} = -\omega^2 r \cos (\omega t + C) = -k^2 x = \text{acceleration of } Q.$

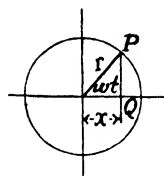

FIG. 543.

From this it will be seen that the acceleration is constantly negatively proportional to the displacement  $x$ .

Many motions, such as the oscillations of particles in wave motions, light and sound waves, alternating currents, and vibrating springs, can be represented as simple harmonic motions, and their motion is described by the above formulae.

**944. Another Simple Harmonic Motion Problem.**—If a body  $m$  which is suspended by a spring is pulled downward from its position of equilibrium a distance  $x$ , an unbalanced force  $F$  will act upward upon the body. This force will be negatively proportional to  $x$  since it acts in a direction opposite to  $x$ .



FIG. 544.

Then

$$F = -kx,$$

where  $k$  is some constant depending on the spring. When the body is released, it will vibrate up and down and  $x$  will vary with the time  $t$ .

The velocity then is  $\frac{dx}{dt}$  and the acceleration is  $\frac{d^2x}{dt^2}$ .

The unbalanced force is  $F = ma$ .

$$\therefore F = m \frac{d^2x}{dt^2} = -kx (\text{since } F = -kx),$$

whence

$$\frac{d^2x}{dt^2} = -\frac{k}{m}x.$$

That is, the second derivative of the function is equal to the function itself multiplied by a constant  $-\frac{k}{m}$ .

If we refer back to Art. 943, we see that the cosine is a function of this kind. We can, therefore, apply the laws developed there to the present case.

Starting with the general form of the cosine function in which time is the independent variable, then

$$\begin{aligned}x &= a \cos (\omega t + \theta). \\ \frac{dx}{dt} &= -\omega a \sin (\omega t + \theta). \\ \frac{d^2x}{dt^2} &= -\omega^2 a \cos (\omega t + \theta).\end{aligned}$$

Substituting  $x$  for  $a \cos (\omega t + \theta)$ ,

$$\frac{d^2x}{dt^2} = -\omega^2 x.$$

But we have made

$$\frac{d^2x}{dt^2} = -\frac{k}{m}x.$$

Hence,

$$\omega^2 = \frac{k}{m}.$$

If the time is considered to start at the time of release, then  $\theta = 0$  and the equation becomes

$$x = a \cos \omega t,$$

where  $x = a$  at the time of release.

**945. Derivative of  $y = \tan u$ .**—From trigonometry,

$$\tan u = \frac{\sin u}{\cos u} \quad [274].$$

We may differentiate this, using the formula for the derivative of a quotient.

$$\frac{d(\tan u)}{du} = \frac{\cos u \frac{d(\sin u)}{du} - \sin u \frac{d(\cos u)}{du}}{\cos^2 u}.$$

But

$$\frac{d(\sin u)}{du} = \cos u \quad \text{and} \quad \frac{d(\cos u)}{du} = -\sin u.$$

Therefore,

$$\frac{d(\tan u)}{du} = \frac{\cos^2 u + \sin^2 u}{\cos^2 u}.$$



From trigonometry,

$$\sin^2 u + \cos^2 u = 1 \quad [265].$$

Therefore,

$$\frac{d(\tan u)}{du} = \frac{1}{\cos^2 u} = \sec^2 u.$$

But

$$\frac{d(\tan u)}{dx} = \frac{d(\tan u)}{du} \cdot \frac{du}{dx} \quad [469].$$

Then

$$[508] \quad \frac{d(\tan u)}{dx} = \sec^2 u \cdot \frac{du}{dx}.$$

If  $y = \tan x$ , then  $u = x$  and

$$[509] \quad \frac{d(\tan x)}{dx} = \sec^2 x.$$

Further, the derivative of the general form,

$$[510] \quad \frac{d[\tan (Bx + C)]}{dx} = B \sec^2 (Bx + C).$$

Also,

$$[511] \quad \frac{d[A \tan (Bx + C)]}{dx} = AB \sec^2 (Bx + C).$$

#### 946. Other Trigonometric Derivatives.

$$y = \cot u.$$

$$[512] \quad \frac{dy}{dx} = \frac{d(\cot u)}{dx} = -\csc^2 u \cdot \frac{du}{dx}.$$

For general form,

$$[513] \quad \frac{d[A \cot (Bx + C)]}{dx} = -AB \csc^2 (Bx + C).$$

$$y = \sec u.$$

$$[514] \quad \frac{dy}{dx} = \frac{d(\sec u)}{dx} = \sec u \cdot \tan u \cdot \frac{du}{dx}.$$

For the general form,

$$[515] \quad \frac{d[A \sec (Bx + C)]}{dx} = AB \sec (Bx + C) \cdot \tan (Bx + C),$$

$$y = \csc u.$$

$$[516] \quad \frac{dy}{dx} = \frac{d(\csc u)}{dx} = -\csc u \cdot \cot u \cdot \frac{du}{dx}.$$

For the general form,  $y = A \csc (Bx + C)$ ,

$$[517] \quad \frac{dy}{dx} = \frac{d[A \csc (Bx + C)]}{dx} = -AB \csc (Bx + C) \cdot \cot (Bx + C).$$

**947. Examples of Trigonometric Differentiation.**

EXAMPLE 1.—Differentiate  $y = \cos^3 \theta$ .

This is the same as  $(\cos \theta)^3 = y$ .

Let  $u = \cos \theta$ ; then

$$\frac{du}{d\theta} = -\sin \theta.$$

$$\therefore y = u^3 \text{ and } \frac{dy}{du} = 3u^2.$$

Since

$$\frac{dy}{d\theta} = \frac{dy}{du} \cdot \frac{du}{d\theta}, \quad [469]$$

$$\therefore \frac{dy}{d\theta} = -3 \cos^2 \theta \cdot \sin \theta.$$

EXAMPLE 2.—Differentiate  $y = \sqrt{1 + 3 \tan^2 \theta} = (1 + 3 \tan^2 \theta)^{\frac{1}{2}}$ .

Let  $u = 3 \tan^2 \theta$ , whence

$$\frac{du}{d\theta} = 6 \tan \theta \cdot \frac{d(\tan \theta)}{d\theta} = 6 \tan \theta \cdot \sec^2 \theta.$$

$y = (1 + u)^{\frac{1}{2}}$ , whence

$$\frac{dy}{du} = \frac{1}{2}(1 + u)^{-\frac{1}{2}} \cdot \frac{d(1 + u)}{du} = \frac{1}{2\sqrt{1 + u}} = \frac{1}{2\sqrt{1 + 3 \tan^2 \theta}}$$

$$\frac{dy}{d\theta} = \frac{dy}{du} \cdot \frac{du}{d\theta} = \frac{6 \tan \theta \cdot \sec^2 \theta}{2\sqrt{1 + 3 \tan^2 \theta}}$$

EXAMPLE 3.—Differentiate  $y = \sin x \cdot \cos x$ .

Differentiate as a product of two functions.

$$\frac{dy}{dx} = \sin x \frac{d(\cos x)}{dx} + \cos x \frac{d(\sin x)}{dx} = \sin x(-\sin x) +$$

$$\cos x(\cos x) = \cos^2 x - \sin^2 x.$$

**948. Derivatives of Inverse Trigonometric Functions.**

Differentiate  $y = \sin^{-1} u$ .

Then

$$u = \sin y.$$

$$\frac{du}{dy} = \cos y.$$

Consider the triangle of Fig. 545. It is apparent that  $u = \sin y$  and that  $\cos y = \sqrt{1 - u^2}$ ; whence

$$\frac{du}{dy} = \cos y = \sqrt{1 - u^2}.$$

But

$$\frac{dy}{du} = \frac{1}{\frac{du}{dy}} = \frac{1}{\sqrt{1 - u^2}}.$$

Also,

$$[518] \quad \frac{dy}{dx} = \frac{dy}{du} \cdot \frac{du}{dx} = \frac{du}{\sqrt{1-u^2}}$$

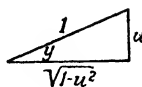

FIG. 545.

Differentiate  $y = \cos^{-1} u$ .

In the same manner, namely, by the use of the triangle of Fig. 545, the differentiation of  $y = \cos^{-1} u$  gives

$$[519] \quad \frac{dy}{dx} = -\frac{du}{\sqrt{1-u^2}}$$

949. Using the fundamental triangle of Fig. 546, in a manner similar to that used in the preceding cases, we may find the derivatives of the inverse tangent and cotangent.

Differentiate  $y = \tan^{-1} u$ .

$$[520] \quad \frac{dy}{dx} = \frac{du}{1+u^2}$$

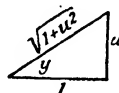

FIG. 546.

Since we have outlined the general method of differentiating the inverse trigonometric functions, we will simply give the derivatives of the others without developing.

$$[521] \quad \frac{d(\cot^{-1} u)}{dx} = -\frac{du}{1+u^2}$$

$$[522] \quad \frac{d(\sec^{-1} u)}{dx} = \frac{du}{u\sqrt{u^2-1}}$$

$$[523] \quad \frac{d(\csc^{-1} u)}{dx} = -\frac{du}{u\sqrt{u^2-1}}$$

$$[524] \quad \frac{d(\text{vers}^{-1} u)}{dx} = \frac{du}{\sqrt{2u-u^2}}$$

950. **Graphical Analysis of Inverse Functions.**—Since the inversion is simply the interchange of the variables which can be accomplished graphically by the rotation of the curve about a line through the origin and making an angle of  $45^\circ$  with the coordinate axes (Art. 629), then for  $y = \sin x$  and for the inverted form,  $y = \sin^{-1} x$ , the graphs are as shown in Fig. 547.

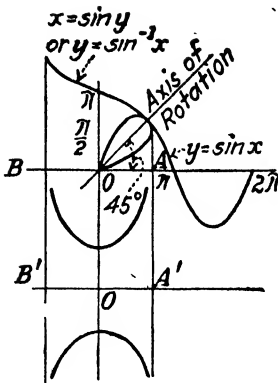

FIG. 547.

$y = \sin^{-1} x$  means that  $y$  is an angle in radians whose sine is equal to  $x$ .

The rotation of the curve about the  $45^\circ$  line as an axis is simply equivalent to interchanging the variables  $x$  and  $y$ . The derived curve, then, is in a vertical instead of a horizontal position.

In other words, we may graphically differentiate  $y = \sin x$  with reference to the  $Y$ -axis instead of with respect to the  $X$ -axis, which would give the derivative of  $x$  with respect to  $y$ , or

$$\frac{dx}{dy} \text{ instead of } \frac{dy}{dx}, \text{ that is, } \frac{dx}{dy} = \frac{1}{\cos x},$$

but since we have interchanged the variables by rotation of the curve,

$$x = \sin y, \text{ or } y = \sin^{-1} x,$$

$$\frac{dy}{dx} = \frac{1}{\cos y} = \frac{1}{\sqrt{1 - \sin^2 y}}.$$

But  $\sin y = x$ ; therefore,

$$\frac{dy}{dx} = \frac{1}{\cos y} = \frac{1}{\sqrt{1 - \sin^2 y}} = \frac{1}{\sqrt{1 - x^2}}.$$

Since  $y$  is restricted to the interval,  $-\frac{\pi}{2} \leq y \leq \frac{\pi}{2}$  (Art. 629),

to make it single valued, the radical is taken as positive.

If  $y$  is restricted to the interval,

$$0 \leq y \leq \pi,$$

the function,  $y = \cos^{-1} x$ , is single valued and its derivative is taken with the negative sign of the radical.

**951. Derivatives of Hyperbolic Functions.**—Since the hyperbolic functions occur so seldom in engineering work, their derivatives will be given without development.

$$[525] \quad \frac{d(\sinh u)}{dx} = \cosh u \cdot \frac{du}{dx}$$

$$[526] \quad \frac{d(\cosh u)}{dx} = \sinh u \cdot \frac{du}{dx}$$

$$[527] \quad \frac{d(\tanh u)}{dx} = \operatorname{sech}^2 u \cdot \frac{du}{dx}$$

$$[528] \quad \frac{d(\coth u)}{dx} = -\operatorname{csch}^2 u \cdot \frac{du}{dx}$$

$$[529] \quad \frac{d(\operatorname{csch} u)}{dx} = -\operatorname{csch} u \cdot \coth u \cdot \frac{du}{dx}$$

$$[530] \quad \frac{d(\operatorname{sech} u)}{dx} = -\operatorname{sech} u \cdot \tanh u \cdot \frac{du}{dx}$$

$$[531] \quad \frac{d(\sinh^{-1} u)}{dx} = \frac{\frac{du}{dx}}{\sqrt{u^2 + 1}}$$

$$[532] \quad \frac{d(\cosh^{-1} u)}{dx} = \frac{\frac{du}{dx}}{\sqrt{u^2 - 1}}$$

$$[533] \quad \frac{d(\tanh^{-1} u)}{dx} = \frac{\frac{du}{dx}}{1 - u^2}$$

$$[534] \quad \frac{d(\coth^{-1} u)}{dx} = -\frac{\frac{du}{dx}}{u^2 - 1}$$

$$[535] \quad \frac{d(\operatorname{csch}^{-1} u)}{dx} = -\frac{\frac{du}{dx}}{u\sqrt{1 + u^2}}$$

$$[536] \quad \frac{d(\operatorname{sech}^{-1} u)}{dx} = -\frac{\frac{du}{dx}}{u\sqrt{1 - u^2}}$$

## CHAPTER XLVI

### DIFFERENTIATION OF LOGARITHMIC AND EXPONENTIAL FUNCTIONS

**952. Derivative of  $\log_a u$ .**—Let  $y = \log_a u$ , where  $u$  is some function of  $x$ .

Let  $x_0$  be some definite value of  $x$  and let  $y_0$  and  $u_0$  be the corresponding values of  $y$  and  $u$ .

Therefore,  $y_0 = \log_a u_0$ .

Let  $x$  take an increment  $\Delta x$ ; then

$$x = x_0 + \Delta x \text{ and } y = y_0 + \Delta y = \log_a (u_0 + \Delta u).$$

Subtracting,

$$\begin{aligned} \Delta y &= \log_a (u_0 + \Delta u) - \log_a u_0 \\ &= \log_a \left( \frac{u_0 + \Delta u}{u_0} \right) = \log_a \left( 1 + \frac{\Delta u}{u_0} \right). \end{aligned}$$

Dividing by  $\Delta u$ ,

$$\frac{\Delta y}{\Delta u} = \frac{\log_a \left( 1 + \frac{\Delta u}{u_0} \right)}{\Delta u} = \frac{1}{\Delta u} \cdot \log_a \left( 1 + \frac{\Delta u}{u_0} \right).$$

Multiplying and dividing the right member by  $u_0$ ,

$$\frac{\Delta y}{\Delta u} = \frac{1}{u_0} \cdot \frac{u_0}{\Delta u} \log_a \left( 1 + \frac{\Delta u}{u_0} \right).$$

Since  $m \cdot \log_a N = \log_a N^m$ ,

$$\frac{\Delta y}{\Delta u} = \frac{1}{u_0} \log_a \left( 1 + \frac{\Delta u}{u_0} \right)^{\frac{u_0}{\Delta u}}.$$

$$\text{Limit}_{\Delta x \rightarrow 0} \left[ \frac{\Delta y}{\Delta u} \right] = \frac{dy}{du} = \text{Limit}_{\Delta x \rightarrow 0} \left[ \frac{1}{u_0} \left[ \log_a \left( 1 + \frac{\Delta u}{u_0} \right)^{\frac{u_0}{\Delta u}} \right] \right].$$

We have therefore to find

$$\text{Limit}_{\Delta x \rightarrow 0} \left[ \log_a \left( 1 + \frac{\Delta u}{u_0} \right)^{\frac{u_0}{\Delta u}} \right].$$

Let  $\frac{u_0}{\Delta u} = z$ .

As  $\Delta x$  approaches zero,  $\Delta u$  approaches zero and  $\frac{u_0}{\Delta u}$ , or  $z$ , approaches infinity.

Substituting  $z$  for  $\frac{u_0}{\Delta u}$  in the above, then we are to find

$$\text{Limit}_{z \rightarrow \infty} \left[ \log_a \left( 1 + \frac{1}{z} \right)^z \right].$$

By the binomial theorem,

$$\left( 1 + \frac{1}{z} \right)^z = 1 + z \frac{1}{z} + \frac{z(z-1)}{2} \left( \frac{1}{z} \right)^2 + \frac{z(z-1)(z-2)}{3} \left( \frac{1}{z} \right)^3 + \dots$$

Then

$$\left( 1 + \frac{1}{z} \right)^z = 1 + 1 + \frac{1 - \frac{1}{z}}{2} + \frac{\left( 1 - \frac{1}{z} \right) \left( 1 - \frac{2}{z} \right)}{3} + \dots +$$

And

$$\text{Limit}_{z \rightarrow \infty} \left[ \left( 1 + \frac{1}{z} \right)^z \right] = \text{Limit}_{z \rightarrow \infty} \left[ 1 + 1 + \frac{1 - \frac{1}{z}}{2} + \frac{\left( 1 - \frac{1}{z} \right) \left( 1 - \frac{2}{z} \right)}{3} + \dots + \right].$$

As  $z$  approaches infinity,  $\left( 1 - \frac{1}{z} \right)$ ,  $\left( 1 - \frac{2}{z} \right)$ , etc., approach unity, and

$$\text{Limit}_{z \rightarrow \infty} \left[ \left( 1 + \frac{1}{z} \right)^z \right] = \text{Limit}_{n \rightarrow \infty} \left[ 1 + 1 + \frac{1}{2} + \frac{1}{3} + \dots + \frac{1}{n-1} \right].$$

Therefore,

$$[537] \quad \frac{dy}{du} = \frac{1}{u_0} \log_a \left[ 1 + 1 + \frac{1}{2} + \frac{1}{3} + \frac{1}{4} + \dots \right].$$

The quantity in the brackets is denoted by  $e$  and is a convergent infinite series (Arts. 343, 462).

$$[538] \quad \frac{dy}{du} = \frac{1}{u_0} \log_a e.$$

Since

$$\frac{dy}{dx} = \frac{dy}{du} \cdot \frac{du}{dx}, [469]$$

$$[539] \quad \frac{dy}{dx} = \frac{1}{u} \cdot \frac{du}{dx} \log_a e,$$

or

$$\frac{d(\log_a u)}{dx} = \frac{1}{u} \cdot \frac{du}{dx} \log_a e.$$

If the base  $a$  equals  $e$ , then  $\log_e e = 1$ , and

$$[540] \quad \frac{d(\log_e u)}{dx} = \frac{1}{u} \cdot \frac{du}{dx}$$

The limit of the sum of the infinite series  $e$  is the base of the Napierian system of logarithms and is equal to 2.71828 . . . when the infinite series is developed.

Further, if  $y = \log x$ ,

$$[541] \quad \frac{dy}{dx} = \frac{\log e}{x},$$

regardless of the base.

If the base is  $e$ , then  $\log e = 1$ .

Hence, if  $y = \log_e x$ , then

$$[542] \quad \frac{dy}{dx} = \frac{1}{x}.$$

But if the base is 10,  $\log_{10} e = .43429 = M$ .

Hence, if  $y = \log_{10} x$ , then

$$[543] \quad \frac{dy}{dx} = \frac{M}{x}.$$

The above formulae show that the rate at which a logarithm increases with respect to the number is inversely proportional to the number. Geometrically, this means that the graph of  $y = \log_e x$  has a slope of 1 at the point  $x = 1$ , a slope of  $\frac{1}{2}$  at the point  $x = 2$ , a slope of  $\frac{1}{3}$  at the point  $x = 3$ , etc.

This is the inverse of the case of the exponential function, since there the rate of increase is *directly* proportional to the value of the function at any point.

### 953. Log Differentiation of General Form.

$$[544] \quad \frac{d[\log_e (Ax + B)]}{dx} = \frac{A}{Ax + B}$$

$$[545] \quad \frac{d[\log_{10} (Ax + B)]}{dx} = \frac{.4343A}{Ax + B}$$

EXAMPLE.—Differentiate

$$y = \log_e (a + bx + cx^2).$$

Then  $y = \log_e u$  where  $u = a + bx + cx^2$ .

$$\frac{dy}{dx} = \frac{1}{u} \cdot \frac{du}{dx} \quad [540]$$

$$\frac{du}{dx} = b + 2cx.$$



But

$$\frac{dy}{dx} = \frac{dy}{du} \cdot \frac{du}{dx} = \frac{1}{u} (b + 2cx) = \frac{b + 2cx}{a + bx + cx^2}.$$

EXAMPLE.—Find the derivative by logarithmic method of

$$y = \frac{u^n v^m}{w^p},$$

where  $u, v,$  and  $w$  are functions of  $x$  and  $n, m,$  and  $p$  are constants.

Then

$$\log_e y = n \log_e u + m \log_e v - p \log_e w.$$

$$\frac{d(\log_e y)}{dx} = \frac{d(\log_e u)}{dx} \cdot \frac{dy}{dy} \text{ but } \frac{d(\log_e y)}{dy} = \frac{1}{y}.$$

Therefore,

$$\frac{d(\log_e y)}{dx} = \frac{1}{y} \cdot \frac{dy}{dx}$$

Proceeding,

$$\begin{aligned} \frac{1}{y} \cdot \frac{dy}{dx} &= n \frac{d(\log_e u)}{dx} + m \frac{d(\log_e v)}{dx} - p \frac{d(\log_e w)}{dx} \\ &= \frac{n}{u} \cdot \frac{du}{dx} + \frac{m}{v} \cdot \frac{dv}{dx} - \frac{p}{w} \cdot \frac{dw}{dx} \\ \frac{dy}{dx} &= y \left[ \frac{n}{u} \cdot \frac{du}{dx} + \frac{m}{v} \cdot \frac{dv}{dx} - \frac{p}{w} \cdot \frac{dw}{dx} \right] = \frac{u^n v^m}{w^p} \left[ \frac{n}{u} \cdot \frac{du}{dx} + \frac{m}{v} \cdot \frac{dv}{dx} - \frac{p}{w} \cdot \frac{dw}{dx} \right]. \end{aligned}$$

### 954. Comparison of Methods of Differentiating.

EXAMPLE.—Differentiate

$$y = (2x^3 - 1)(1 + x^3)^2.$$

Using formula for the derivative of a product,

$$\frac{dy}{dx} = u \frac{dv}{dx} + v \frac{du}{dx} \quad [472].$$

Let  $u = 2x^3 - 1,$  and  $v = (1 + x^3)^2 = z^2$  where  $z = 1 + x^3.$

$$\frac{du}{dx} = 6x^2, \quad \frac{dv}{dz} = 2z, \quad \frac{dz}{dx} = 3x^2.$$

$$\frac{dv}{dx} = \frac{dv}{dz} \cdot \frac{dz}{dx} = 2(1 + x^3)(3x^2) = 6x^2(1 + x^3).$$

Then

$$\begin{aligned} \frac{dy}{dx} &= (2x^3 - 1)(6x^2)(1 + x^3) + (1 + x^3)^2(6x^2) \\ &= 6x^2(2x^3 - 1)(1 + x^3) + 6x^2(1 + x^3)^2, \end{aligned}$$

which reduces to

$$\frac{dy}{dx} = 18x^6 + 18x^3.$$

Consider the same problem, using

$$\log y = \log u + \log v.$$

$$\frac{1}{y} \cdot \frac{dy}{dx} = \frac{1}{u} \cdot \frac{du}{dx} + \frac{1}{v} \cdot \frac{dv}{dx} \quad [474].$$

Since, from the above,

$$\frac{du}{dx} = 6x^2 \text{ and } \frac{dv}{dx} = 6x^2(1 + x^3),$$

then

$$\begin{aligned} \frac{1}{y} \cdot \frac{dy}{dx} &= \frac{1}{2x^3 - 1} \cdot 6x^2 + \frac{1}{(1 + x^3)^2} \cdot 6x^2(1 + x^3). \\ &= \frac{6x^2}{2x^3 - 1} + \frac{6x^2}{1 + x^3}. \end{aligned}$$

Multiplying through by  $y$ , or  $(2x^3 - 1)(1 + x^3)^2$ ,

$$\begin{aligned} \frac{dy}{dx} &= \frac{6x^2(2x^3 - 1)(1 + x^3)^2}{2x^3 - 1} + \frac{6x^2(2x^3 - 1)(1 + x^3)^2}{1 + x^3} \\ &= 6x^2(1 + x^3)^2 + 6x^2(2x^3 - 1)(1 + x^3). \\ &= 18x^8 + 18x^5. \end{aligned}$$

After experience with the logarithmic method, it will be found to be the most satisfactory one to use.

**955. Graphical Comparison of  $y = \log x$  and the Derived Curve**

$y = \frac{1}{x}$ .—If the ordinates of the derived curve, or  $y' = \frac{dy}{dx}$ , are represented by  $y'$ , then the equation for the derived curve is

$$xy' = 1,$$

which represents an equilateral hyperbola. Here, we have a connection between the logarithmic curve and the hyperbola, and for this reason the natural logs are sometimes called hyperbolic logs. Since the common logs are .4343 times the values of the corresponding natural logs, or the values of the natural logs are 2.303 times the value of the corresponding common logs, the two systems can be represented by the same curve by changing the scale of the ordinates as shown in Fig. 548.

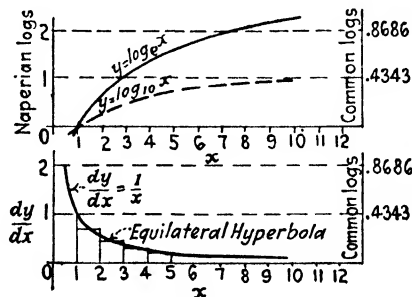

FIG. 548.

This change also applies to the derived curve. The equation for the derived curve for the common log system whose base is 10 is then

$$y' = \frac{dy}{dx} = \frac{.4343}{x}$$

This graph will make clear the relations between the two log systems. If we draw the common log graph to the same vertical scale as the natural log graph, we have a curve similar to that indicated by the dotted line in Fig. 548. It will be noted that the ordinates are 2.303 times greater in the natural log than in the common log graph.

The derived curve for the common log is also an equilateral hyperbola.

**956. Derivative of Exponential Function.**

Let  $y = a^u$ ,

where  $u$  is some function of  $x$ .

Taking the logarithm of both members of the equation,

$$\log_e y = u \cdot \log_e a.$$

Differentiating both sides with respect to  $x$ ,

$$\frac{1}{y} \cdot \frac{dy}{dx} = \frac{du}{dx} \cdot \log_e a.$$

[546]  $\frac{dy}{dx} = y \cdot \frac{du}{dx} \cdot \log_e a = a^u \cdot \frac{du}{dx} \cdot \log_e a.$

A special case is where  $a = e$ ; then  $\log_e e = 1$  and

[547]  $\frac{dy}{dx} = \frac{d(e^u)}{dx} = e^u \cdot \frac{du}{dx}.$

If  $u = x$ , then

$$y = e^x.$$

[548]  $\frac{dy}{dx} = e^x.$

Since the function,  $y = e^x$ , is the inverse of  $y = \log_e x$ , then, as previously explained (Art. 361),  $y = \log^{-1} x$ , or  $y$  is the number whose log is  $x$ .

But the number, whose log to the base  $e$  is  $x$ , is  $e^x$ , or  $\log^{-1} x = e^x$ .

Hence,

$$y = e^x.$$

A peculiarity of the function,

$$y = e^x,$$

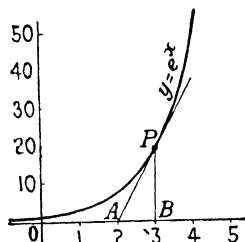

FIG. 549.

is that the derivative is also  $e^x$ ; that is,

$$y' = \frac{dy}{dx} = e^x.$$

This means that the derived curve of the primary curve  $y = e^x$  is the curve itself.

The length of the subtangent is constant and equal to 1. The subtangent at the point  $P$  is shown in the graph as  $AB$ . Since the primary curve is also the derived curve, only one curve is shown (see Art. 362). The subtangent is constant not only for  $y = e^x$  but also for the more general cases,  $y = ce^{nx}$  or  $y = ca^x$ .

**EXAMPLE.**—Differentiate

$$y = e^u, \text{ where } u = \sin^{-1} x.$$

$$\frac{dy}{du} = e^u, \frac{du}{dx} = \frac{1}{\sqrt{1-x^2}}.$$

But

$$\frac{dy}{dx} = \frac{dy}{du} \cdot \frac{du}{dx} = \frac{e^u}{\sqrt{1-x^2}} = \frac{e^{\sin^{-1} x}}{\sqrt{1-x^2}}.$$

**957. Derivative of  $y = u^v$ , where  $u$  and  $v$  are both functions of  $x$ .**

Taking the logarithms of both members,

$$\log_e y = v \cdot \log_e u.$$

Differentiating both sides with respect to  $x$ ,

$$\frac{1}{y} \cdot \frac{dy}{dx} = \frac{v}{u} \cdot \frac{du}{dx} + \frac{dv}{dx} \cdot \log_e u.$$

$$\frac{dy}{dx} = y \left( \frac{v}{u} \cdot \frac{du}{dx} + \frac{dv}{dx} \cdot \log_e u \right).$$

Since  $y = u^v$ ,

$$[549] \quad \frac{dy}{dx} = vu^{v-1} \cdot \frac{du}{dx} + u^v \cdot \frac{dv}{dx} \cdot \log_e u.$$

**EXAMPLE.**—Differentiate  $y = (1+x^2)^{\sin x}$ .

$$y = u^v \text{ where } u = (1+x^2) \text{ and } v = \sin x.$$

$$\frac{du}{dx} = 2x \text{ and } \frac{dv}{dx} = \cos x.$$

Substituting in formula,

$$\frac{dy}{dx} = \sin x (1+x^2)^{\sin x - 1} \cdot 2x + \cos x (1+x^2)^{\sin x} \cdot \log_e (1+x^2).$$

**958. Relative Rate of Increase and Compound Interest Law.**

If the rate of change of a function is divided by the function itself, the quotient is the rate of change of the function per unit value of the function. This quotient,

$$\frac{\frac{dy}{dt}}{y}, \text{ or } \frac{1}{y} \cdot \frac{dy}{dt},$$

is called the *relative rate of increase* of the function.

If the relative rate of increase of a function is a constant, the function varies according to the compound interest law, or

$$[550] \quad \frac{1}{y} \cdot \frac{dy}{dt} = k.$$

Also,

$$[551] \quad \frac{100}{y} \cdot \frac{dy}{dt} = \text{percentage rate of increase.}$$

**Compound Interest Law.**—The compound interest law is

$$A = P \left( 1 + \frac{r}{k} \right)^{kn},$$

in which

$A$  = amount.

$P$  = principal.

$r$  = rate of interest.

$k$  = number of times compounded per year.

$n$  = number of years.

As the number of times compounded per year is increased indefinitely, or as  $k \rightarrow \infty$ , and letting

$$\frac{r}{k} = \frac{1}{z},$$

then,

$$A = P \left( 1 + \frac{1}{z} \right)^{zrn} = P \left[ \left( 1 + \frac{1}{z} \right)^z \right]^{rn}.$$

Then

$$\text{Limit}_{k \rightarrow \infty} P \left[ \left( 1 + \frac{1}{z} \right)^z \right]^{rn} = \text{Limit}_{z \rightarrow \infty} P \left[ \left( 1 + \frac{1}{z} \right)^z \right]^{rn}.$$

But from Art. 952,

$$\left(1 + \frac{1}{z}\right)^z = e.$$

Hence,

[552] 
$$A = Pe^{rn}.$$

This is the amount of any principal  $P$  after  $n$  years with interest compounded *continuously* at any annual rate  $r$ . For negative values of  $r$  the formula represents a depreciating investment. Since  $r$  is negative,  $z$  is also negative and  $\left(1 + \frac{1}{z}\right)^z$  still approaches  $e$  if  $k \rightarrow \infty$ .

EXAMPLE.—If the continuous rate is 6 per cent depreciation, then

$$A = P(e)^{-6n}.$$

The base  $e$  can be changed to any other base as 10, remembering that  $e = 10 \cdot 43429$ . Then

$$A = P(10 \cdot 43429)^{rn} = P \cdot 10 \cdot 43429^{rn}.$$

The identity of  $r$  in this form, however, disappears, which makes the  $e$  base more satisfactory.

The compound interest law may be stated thus:

If any quantity, as  $y$ , varies in such a way that its rate of increase (or decrease) with respect to another quantity, as  $x$ , is constantly proportional to itself, it varies according to the compound interest law. Then

$$y = P(e)^{rx},$$

where  $P$  is the value of  $y$  at  $x = 0$  and  $r$  is the fixed percentage rate of increase.

EXAMPLE.—The speed of a certain chemical reaction  $v$  increases 10 per cent with every degree rise in temperature. Obtain a formula for  $v$  at any temperature.

$$v = P(1.10)^t.$$

If  $t = 0$ ,  $v = P$ .

From a table of natural logs,

$$1.10 = e^{.0953}.$$

Then

$$v = P(e^{.0953})^t = Pe^{.0953t},$$

where  $P$  is the velocity of the reaction at  $0^\circ$ .

**959. Graphical Differentiation by Use of Exponential Curve.**—From the development of the exponential derivative, we know

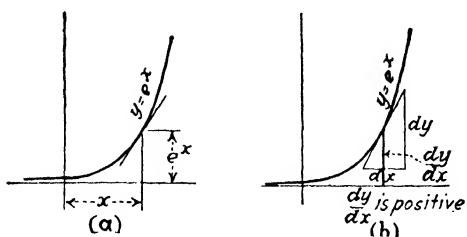

FIG. 550.

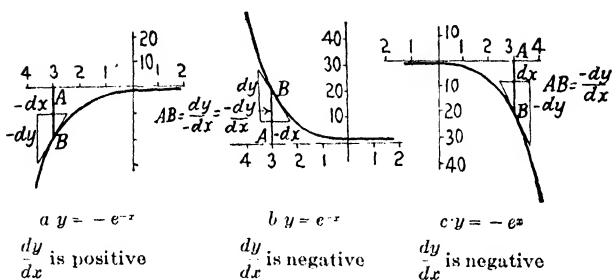

FIG. 551

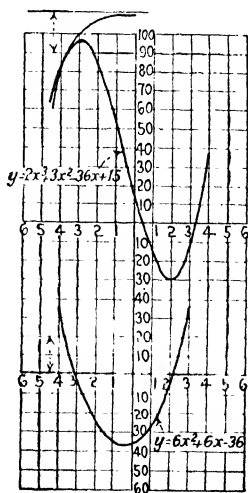

FIG. 552.

that the ordinate of a point measures the slope of the exponential curve at that point. That is,

$$\frac{d(e^x)}{dx} = e^x.$$

By constructing a set of exponential curves, that is,

$$y = e^x, y = -e^{-x}, y = e^{-x}, \text{ and } y = -e^x,$$

on tracing cloth, we are able to lay off the ordinates of any differential curve simply by laying the proper exponential curve over the graph of the given curve. We find a point on the exponential curve by shifting about until the slope is found to be the same as that of the given curve and lay off for the derived curve an ordinate equal to the ordinate of the exponential curve at that point.

In case the ordinates are plotted to a different scale from the abscissa, we can adjust the plotting to suit the case  $y = e^{bx}$  by dividing the horizontal or  $X$ -scale by  $b$ , which makes it a graph of  $y = e^{bx}$  (see Art. 381).

A sample graph is shown in Fig. 552 with a portion of the exponential graph shown sketched at the point of tangency to illustrate the method.



## CHAPTER XLVII

### DIFFERENTIALS

**960. Differential Notation.**—Let the dependent variable  $y$  be a function of the independent variable  $x$ . Moreover, let  $dx$ , called the *differential of the independent variable*, represent an increment of the independent variable. That is,  $dx = \Delta x$ . We then define the differential of the dependent variable, or the differential of the function, or the differential of  $y$ , or simply  $dy$ , to be the differential of the independent variable multiplied by the derivative of the function; that is,

$$dy = \left(\frac{dy}{dx}\right)dx,$$

in which the symbol  $\frac{dy}{dx}$  is a derivative and not a fraction.

Dividing through by  $dx$ , we have

$$\frac{dy}{dx} = \left(\frac{dy}{dx}\right),$$

where the left member is a fraction and represents the quotient of two differentials and the right member is a derivative. According to this definition of differentials, we may regard the derivative as the quotient of two differentials. In this connection it is important to note that while  $dx = \Delta x$ ,  $dy$  is not, in general, equal to  $\Delta y$ . The differential of the independent variable is an increment, but the differential of the dependent variable is the product of a derivative and the increment of the independent variable. That is, the derivative of  $y$  with respect to  $x$  is equal to the fraction  $\frac{dy}{dx}$  but it is not equal to the fraction

$$\frac{\Delta y}{\Delta x}$$

If

$$\frac{dy}{dx} = 2x,$$

we can operate on the equation as we would on a fraction; that is,

$$dy = 2x \cdot dx.$$

Also if we have the product of two derivatives,

$$\frac{dy}{du} \cdot \frac{du}{dx},$$

we may cancel the  $du$ , and the expression reduces to  $\frac{dy}{dx}$ .

In the same manner, if  $y = u + v$ ,

$$\frac{dy}{dx} = \frac{du}{dx} + \frac{dv}{dx},$$

and [553]

$$dy = du + dv.$$

Also, if  $y = uv$ , then

$$\frac{dy}{dx} = u \cdot \frac{dv}{dx} + v \cdot \frac{du}{dx},$$

and [554]

$$dy = u \cdot dv + v \cdot du.$$

Also, if  $y = \frac{u}{v}$ , then

$$\frac{dy}{dx} = \frac{v \cdot \frac{du}{dx} - u \cdot \frac{dv}{dx}}{v^2},$$

and [555]

$$dy = \frac{v \cdot du - u \cdot dv}{v^2} \cdot dx.$$

**961. Application of Differentials to Curves.**—Let  $P(x, y)$  be any point on the curve, and let  $PA$  be the tangent to the curve at  $P$  (Fig. 553).

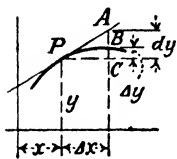

FIG. 553.

Let  $x$  take an increment  $\Delta x$ , which by definition is equal to  $dx$ . Also,  $dy$ , the differential of the function, is equal to the derivative of the function multiplied by  $dx$ . Since the derivative of the function is equal to the tangent of the angle  $CPA$ , then

$$dy = \tan CPA \cdot dx.$$

But

$$\frac{CA}{dx} = \tan CPA \text{ or } CA = \tan CPA \cdot dx,$$

whence  $CA = dy$ .

Note that  $\Delta y = BC$ .

The differential of a function  $y$ , that is,  $dy$ , is the amount that  $y$  would increase while  $x$  increases a certain amount  $dx$  if the rate remained the same throughout the interval  $dx$  as at the beginning of the interval.

We have considered the rate of change of the dependent variable with respect to the independent variable as the limit of a ratio and we have called this limit the derivative. We have written this limiting value of the ratio,

$$\frac{dy}{dx} = \text{some quantity (constant or variable)} = k.$$

We have just seen that we may write this in the form,

$$dy = k \cdot dx,$$

$$k = f'(x).$$

where

The differential equation then is

[556] 
$$dy = f'(x) \cdot dx,$$

where  $f'(x)$  is the rate of change of the dependent variable with respect to the independent variable.

**962. Length of a Curve.**—The length of a curve is the limit of the perimeter length of the inscribed polygon when the number of its sides is allowed to increase without bound. To see the reason for this, consider how you would measure with a rule. You may consider a flexible rule which would become inaccurate in length no matter how thin it were made. It is apparent, then, that it is quite essential to adopt the idea of the inscribed polygon as above given.



FIG. 554.

We will assume that the limiting value of the ratio between a small chord and the arc that it subtends as the adjacent points  $P$  and  $P'$  on the curve approach each other is

$$\lim_{P \rightarrow P'} \left[ \frac{\text{chord } PP'}{\text{arc } PP'} \right] = 1.$$



FIG. 555.

It is immaterial whether  $P$  is considered as approaching  $P'$ , or  $P'$  as approaching  $P$ , since the limit of their distance from each other is zero.

**963. Differential of an Arc.**—Let  $s$  be the distance measured on a curve from  $A$  to a variable point  $P$ . Let  $\phi$  be the angle  $BPT$ . If  $P$  moves a very small distance to  $P'$ , the increments in  $x$ ,  $y$ , and  $s$  are

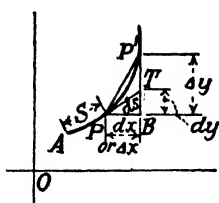

FIG. 556.

$$\Delta x = PB,$$

$$\Delta y = BP', \text{ and}$$

$$\Delta s = \text{arc } PP'.$$

From the diagram (Fig. 556),

$$\cos \angle BPP' = \frac{\Delta x}{PP'} = \frac{\Delta x}{\Delta s} \cdot \frac{\Delta s}{PP'}$$

$$\sin \angle BPP' = \frac{\Delta y}{PP'} = \frac{\Delta y}{\Delta s} \cdot \frac{\Delta s}{PP'}$$

As  $P$  approaches  $P'$ ,  $\angle BPP'$  approaches  $\phi$ , and

$$\frac{\Delta s}{PP'} = \frac{\text{arc } PP'}{\text{chord } PP'} \text{ approaches } 1.$$

Then, at the limit,

$$\cos \phi = \frac{dx}{ds} \text{ and } \sin \phi = \frac{dy}{ds}$$

This means that  $dx$  and  $dy$  are the sides of a right triangle with hypotenuse  $ds$  extending along the tangent to the curve at the point  $P$ .

It must be borne in mind that since  $x$  is the independent variable,  $dx = \Delta x$ , but since  $y$  and  $s$  are dependent variables,  $dy$  does not equal  $\Delta y$  nor does  $ds$  equal  $\Delta s$ . This is shown by the figure.

Hence, we have the important differential equation,

$$[557] \quad (ds)^2 = (dx)^2 + (dy)^2,$$

or

$$[558] \quad ds = \sqrt{1 + \left(\frac{dy}{dx}\right)^2} dx.$$

$$[559] \quad ds = \sqrt{1 + \left(\frac{dx}{dy}\right)^2} dy.$$

## CHAPTER XLVIII

### CURVE ANALYSIS

**964. Parametric Equations.**—If the equations of a curve are given in parametric form,

$$[560] \quad x = f(t) \text{ and } y = \varphi(t),$$

it is often convenient to find the derivative of  $y$  with respect to  $x$  without first eliminating  $t$  between the two equations. Both  $x$  and  $y$  are functions of  $t$ , and  $y$  is a function of  $x$ . From the relation of a function,

$$\frac{dy}{dt} = \frac{dy}{dx} \cdot \frac{dx}{dt}. \quad [469]$$

Then

$$[561] \quad \frac{dy}{dx} = \frac{\frac{dy}{dt}}{\frac{dx}{dt}}$$

**EXAMPLE.**—If  $x = t^2 + t$  and  $y = t - 1$ , find  $\frac{dy}{dx}$ .

$$\frac{dx}{dt} = 2t + 1. \quad \frac{dy}{dt} = 1.$$

$$\frac{dy}{dx} = \frac{1}{2t + 1}.$$

**965. Velocity Components in Space.**—If a particle is moving along a curve in space, the projection of its velocity vector on the three coordinate axes is called its *velocity components*. In Fig. 557,

$$PQ = \frac{dx}{dt}$$

$$QR = \frac{dy}{dt}$$

$$RT = \frac{dz}{dt}$$

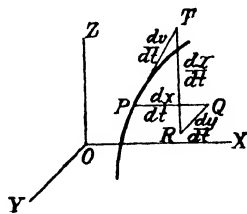

FIG. 557.

But

$$\left(\frac{dv}{dt}\right)^2 = \left(\frac{dx}{dt}\right)^2 + \left(\frac{dy}{dt}\right)^2 + \left(\frac{dz}{dt}\right)^2.$$

Since

$$(PT)^2 = (PQ)^2 + (QR)^2 + (RT)^2,$$

then

$$[562] \quad \frac{dv}{dt} = \sqrt{\left(\frac{dx}{dt}\right)^2 + \left(\frac{dy}{dt}\right)^2 + \left(\frac{dz}{dt}\right)^2}.$$

EXAMPLE.—From Art. 880, the parametric equations of a helix are

$$x = r \cos \theta, \quad y = r \sin \theta, \quad z = k\theta,$$

where  $\theta$  is the angle through which the point has turned about the axis,  $r$  = radius of the helix, and  $k$  is a constant depending upon the pitch of the helix.

Find the instantaneous tangential speed of a point moving on the spiral when  $\theta$  is increasing at the rate of 2 radians per second.

$$\frac{dx}{dt} = -r \sin \theta \cdot \frac{d\theta}{dt}.$$

$$\frac{dy}{dt} = r \cos \theta \cdot \frac{d\theta}{dt}.$$

$$\frac{dz}{dt} = k \cdot \frac{d\theta}{dt}.$$

$$\frac{d\theta}{dt} = 2.$$

$$\frac{dx}{dt} = -2r \sin \theta.$$

$$\frac{dy}{dt} = 2r \cos \theta.$$

$$\frac{dz}{dt} = 2k.$$

Then

$$\begin{aligned} \frac{ds}{dt} &= \sqrt{(-2r \sin \theta)^2 + (2r \cos \theta)^2 + (2k)^2} \\ &= 2\sqrt{r^2 + k^2}. \end{aligned}$$

**966. Curve Slopes.**—There are a few precautions to be taken in finding a particular value of the derivative or the slope of the curve at a particular point.

As an instance, consider the fractional power curves which have abrupt cusps as indicated in Fig. 558, which is a graph of

$$y = x^{\frac{1}{2}} + 1.$$

This curve has a cusp at the point  $x = 0$  and the derivative is not defined for this point, for

$$\frac{dy}{dx} = \frac{2}{3\sqrt[3]{x}},$$

and when  $x = 0$ , the denominator is zero, and hence, there is no derivative. At this point, the derivative changes its sign from  $-$  to  $+$ .

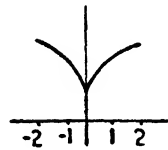

FIG. 558.

The locus of a rotated hyperbola or parabola may present difficulties of this sort, and in any doubtful case, it is a good plan to plot the locus of the equation and any peculiarities will be apparent.

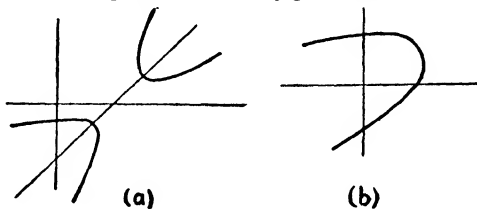

FIG. 559.

**967. Discontinuous Curves.**—We should make sure that the function is continuous for the value of  $x$  for which we are examining the function. If it is in the form of a fraction and if a value of  $x$  can be found for which the denominator of the fraction becomes zero, then the curve is discontinuous at that value of  $x$ . It is, therefore, advisable to set the denominator equal to zero and to solve for  $x$ , and then to test other values of  $x$  near this value to determine the behavior of the derivative in the vicinity of this point. It is possible for the function to be discontinuous in other ways besides the case where the denominator becomes zero, but it is wise to examine the function for this condition.

**968. When the Derivative is Positive or Negative.**—Consider  $y = f(x)$ .

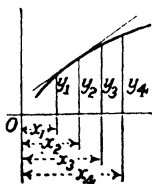

FIG. 560.

If the ordinate, or value of the function, increases as the abscissa  $x$  increases, or if the function increases as a point moves from left to right along the curve, then the function is an increasing one and its graph rises, and therefore, the rate of change  $\frac{dy}{dx}$  is positive.

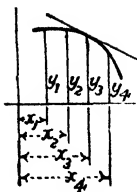

FIG. 561.

The tangent to the curve at a point where the derivative is positive makes an angle of less than  $90^\circ$  with the  $X$ -axis.

If the ordinates, or the values of the function, decrease as the abscissa  $x$  increases, then the curve is falling and the derivative is negative.  $\frac{dy}{dx}$  is negative.

The tangent to the curve at a point where the first derivative is negative makes an angle between  $90^\circ$  and  $180^\circ$  with the  $X$ -axis.

969. If a point may be found on a curve at which the function is neither increasing nor decreasing, the curve at that point is neither rising nor falling, and the tangent to the curve at this point is parallel to the  $X$ -axis, that is, its slope is zero, and the rate of change of the function is zero.

$$\frac{dy}{dx} = 0.$$

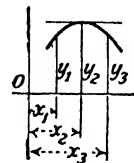

FIG. 562.

It naturally follows that a point, in moving along a curve from left to right and passing through a position for which the derivative changes sign from positive to negative and the curve changes from rising to falling, gives a maximum value for the function at that point. If, however, the point in passing from left to right passes through a position for which the derivative changes sign from negative to positive, such a position determines a *minimum* point on the curve.

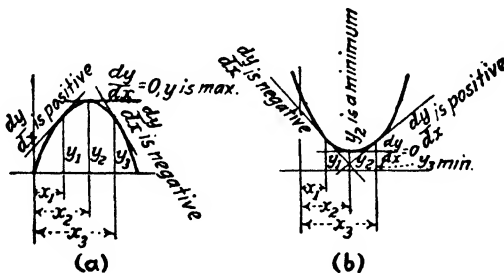

FIG. 563.

370. **Curve Concavity.**—Concavity can best be explained by reference to an actual curve. Take as an illustration the curve  $y = x^3 - 4x$  (Fig. 564).



Assume some position, as  $P_1$ , corresponding to some value of  $x$ , as  $x_1$ . As  $x$  increases in value, or as the point travels from left to right along the curve to the positions  $P_2, P_3, P_4$ , etc., the slope of the tangent, or the derivative  $\frac{dy}{dx}$ , decreases. The curve is concave downward.

Therefore, if the derivative  $\frac{dy}{dx}$  is positive and decreasing, the curve is concave downward.

At position  $P_5$ , the tangent to the curve is parallel to the X-axis; that is, its slope is zero, and

$$\frac{dy}{dx} = 0.$$

As the point moves further to the right to positions  $P_6, P_7, P_8, P_9$ , etc., the slope changes to negative and decreases as  $x$  increases. The curve is concave downward at these points, and we therefore conclude:

If the derivative  $\frac{dy}{dx}$  decreases as  $x$  increases, whether  $\frac{dy}{dx}$  is positive or negative, the curve is concave downward.

As the point travels still further to the right through  $P_1', P_2', P_3'$ , etc., the slope of the tangent, or the value of the derivative, still remains negative but changes from a decreasing to an increasing function, or it increases as  $x$  increases, and the curve is concave upward. At  $P_5'$  the tangent is parallel to the X-axis; that is, its slope is zero, and

$$\frac{dy}{dx} = 0.$$

As the point travels through the positions  $P_6', P_7', P_8', P_9'$ , etc., the slope of the tangent, or the value of the derivative, becomes positive and increases as  $x$  increases, and the curve is still concave upward. We, therefore, conclude that:

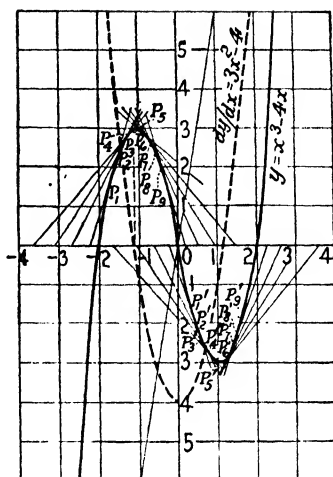

FIG. 564.

If  $\frac{dy}{dx}$  increases as  $x$  increases, whether  $\frac{dy}{dx}$  is positive or negative, the curve is concave upward.

Referring again to Fig. 564, the graph of the curves,

$$y = x^3 - 4x,$$

$$y' = \frac{dy}{dx} = 3x^2 - 4, \text{ and}$$

$$y'' = \frac{d^2y}{dx^2} = 6x,$$

the curves being plotted on the same axes and the ordinates representing  $y$ ,  $\frac{dy}{dx}$ , and  $\frac{d^2y}{dx^2}$ , respectively, an interesting relation will be noted. At the maximum and minimum points of the primary curve, the derived curve intersects the  $X$ -axis or passes through zero values.

For all values of  $x$  for which the first derived curve is above the  $X$ -axis, that is, positive, the primary curve rises to the right. For all values of  $x$  for which the first derived curve is below the  $X$ -axis, that is, negative, the primary curve falls to the right. As  $x$  increases (from left to right) and the positive sign of the first derived curve changes to negative, that is, as the first derived curve crosses from above to below the  $X$ -axis, the primary curve has a maximum at that point, since at this point  $y' = 0$ .

As  $x$  increases and the derived curve crosses the  $X$ -axis from below, or changes in sign from negative to positive, the primary curve has a minimum at the zero point.

For all values of  $x$  for which the second derived curve is above the  $X$ -axis, or positive, the initial curve is concave upward; for all values of the abscissa for which the second derived curve is below the  $X$ -axis, or negative, the initial curve is concave downward.

**971. Points of Inflection.**—For a value of  $x$  at which the second derived curve crosses the  $X$ -axis, or

$$\frac{d^2y}{dx^2} = 0,$$

the initial curve has a point of inflection.

The sign of  $\frac{d^2y}{dx^2}$  changes and, therefore, the initial curve has a reverse bend or a point of inflection. This is also the point of maximum or minimum slope of the curve.

EXAMPLE.

$$y = x^4 - 8x^2 - x + 16.$$

$$y' = \frac{dy}{dx} = 4x^3 - 16x - 1.$$

$$y'' = \frac{d^2y}{dx^2} = 12x^2 - 16.$$

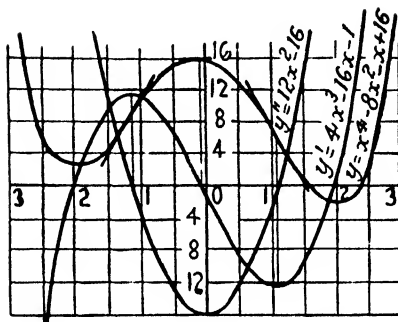

FIG. 565.

Note that the first derived curve crosses the X-axis when the initial curve reaches maximum or minimum values.

The second derived curve crosses the X-axis when the first derived curve reaches maximum or minimum values and at the same points the initial curve has points of inflection.

The second derived curve, it will be noted, is positive for minimum values of the initial function and negative for maximum values of the initial function.

When the second derived curve lies above the X-axis, that is, when

$$\frac{d^2y}{dx^2} > 0,$$

the initial curve is concave upwards, and when the second derived curve is below the X-axis, that is when

$$\frac{d^2y}{dx^2} < 0,$$

the initial curve is concave downwards.

To determine the values of  $x$ , then, for which the initial function has a point of inflection, set the second derivative equal to zero and solve for  $x$ .

**972. Determination of Maximum and Minimum Values.**—A function of one variable, from previous discussions, is said to have a *maximum* value at a point  $x = x_0$  if

$$\text{slope} = \frac{dy}{dx} = 0, \text{ and if } \frac{d^2y}{dx^2} < 0.$$

Similarly, a function of one variable is said to have a *minimum* value at a point  $x = x_0$ , if

$$\text{slope} = \frac{dy}{dx} = 0, \text{ and if } \frac{d^2y}{dx^2} > 0.$$

A rough graph of the initial curve is usually advisable, as this will show the maximum and minimum ordinates without going further.

**973. Rules for Finding Maxima and Minima.**—To solve the following problems in maxima and minima, determine what it is that is to be a maximum or minimum, and then let that be the function, or ordinate  $y$ .

Express  $y$  in terms of a single variable, or in terms of  $x$ . In order to do this, it may be convenient to express  $y$  as a function of a function and then by substitution reduce to a function of a single variable.

Find the first derivative and determine those values of  $x$  which make

$$\frac{dy}{dx} = 0.$$

From the nature of the problem, it is usually easy to decide whether the function has a maximum or a minimum at the point under consideration. If it is not easy to determine this, find the values of the second derivative for the points at which the first derivative is zero.

If  $\frac{d^2y}{dx^2} > 0$ , the function has a minimum at the point.

If  $\frac{d^2y}{dx^2} < 0$ , the function has a maximum at the point.

**EXAMPLE 1.**—A steel cylindrical tank with walls and bottom of uniform thickness is to have a capacity of 5000 cubic feet. Find the dimensions which will make the amount of surface required a minimum.

Let  $h$  = height.

$D$  = diameter.

$s$  = area of surface.

$$s = \frac{\pi D^2}{4} + \pi D h.$$

$$\text{Volume} = \frac{\pi D^2 h}{4} = 5000 \text{ cubic feet (a constant).}$$

Eliminate  $h$  by substituting

$$h = \frac{5000 \times 4}{\pi D^2}$$

in the surface equation. Then

$$s = \frac{\pi D^2}{4} + \frac{20,000 \cdot \pi D}{1} = \frac{\pi D^2}{4} + \frac{20,000}{D}$$

The rate of change of surface with respect to the diameter is

$$\frac{ds}{dD} = \frac{\pi D}{2} - \frac{20,000}{D^2}$$

The function  $s$  will have a minimum when

$$\frac{ds}{dD} = \frac{\pi D}{2} - \frac{20,000}{D^2} = 0.$$

$$\frac{\pi D}{2} = \frac{20,000}{D^2}$$

$$\pi D^3 = 40,000.$$

$$D^3 = 12,731.$$

$$D = 23.3 \text{ feet} = \text{diameter.}$$

Substituting in

$$\frac{\pi D^2 h}{4} = 5000,$$

$$h = 11.6 = \text{depth of tank.}$$

It will be noted that the diameter is twice the depth.

EXAMPLE 2.—A contractor is figuring on a water tunnel from point  $A$  to point  $B$  which is 300 feet below  $A$  and at a distance of 500 feet from  $A$  horizontally. He is allowed to go in any direction through the earth and rock. The cost from his records for this type of excavating is \$10 per linear foot in earth and \$30 per linear foot in rock. What distances in earth and rock will give a minimum cost for the construction?

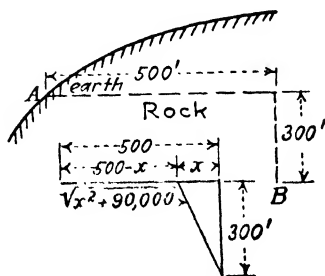

FIG. 566.

Let  $x$  = the horizontal distance as shown in Fig. 566.

$500 - x$  = distance excavated in earth.

$\sqrt{x^2 + 90,000}$  = distance excavated in rock.

Since the cost is the function for which we desire to find the minimum, we make the cost a function of the two distances, or

$$\begin{aligned}\text{Cost} &= 30(\sqrt{x^2 + 90,000}) + 10(500 - x) \\ &= 30(x^2 + 90,000)^{\frac{1}{2}} + 5000 - 10x. \\ \frac{dC}{dx} &= \frac{30}{2}(x^2 + 90,000)^{-\frac{1}{2}} \cdot \frac{d(x^2 + 90,000)}{dx} - 10. \\ &= \frac{30x}{\sqrt{x^2 + 90,000}} - 10.\end{aligned}$$

For the function to have a minimum,  $\frac{dC}{dx}$  must equal 0.

Therefore,

$$\begin{aligned}\frac{30x}{\sqrt{x^2 + 90,000}} - 10 &= 0. \\ \frac{3x}{\sqrt{x^2 + 90,000}} &= 1. \\ 3x &= \sqrt{x^2 + 90,000}.\end{aligned}$$

Squaring,

$$\begin{aligned}x^2 + 90,000 &= 9x^2. \\ 8x^2 &= 90,000. \\ x^2 &= 11,250. \\ x &= 106.07.\end{aligned}$$

$\sqrt{x^2 + 90,000} = \sqrt{(106.07)^2 + 90,000} = 318.2$  feet = the distance to be excavated through rock.

$500 - x = 393.93$  feet = distance through earth.

Cost =  $30(318.2) + 10(393.93) = \$13,485.30$ .

**EXAMPLE 3.**—If the cost per hour for fuel to run a steamer is proportional to the cube of the speed and is \$20 per hour for a speed of 10 knots and if the other expenses amount to \$100 per hour, find the most economical speed in still water.

Cost of fuel =  $F = ks^3$  ( $s$  = knots per hour).

Then  $20 = k(10)^3$ , whence  $k = .02$ .

Therefore,

$$F = .02s^3.$$

Cost of operation per hour =  $.02s^3 + 100$ .

$$\begin{aligned}\text{Cost per knot} = C &= \frac{.02s^3 + 100}{s} \\ &= .02s^2 + 100s^{-1}.\end{aligned}$$

$C$  will have a minimum value when

$$\begin{aligned}\frac{dC}{ds} &= .04s - 100s^{-2} = 0. \\ .04s &= \frac{100}{s^2}.\end{aligned}$$

$$s^3 = 2500.$$

$$s = 13.57 \text{ knots per hour.}$$

To put this into general form:

Let  $k$  = coefficient of  $s$  determined by experiment as above and let  $a$  = fixed charges per hour. Then the most economical speed is given by

$$s = \sqrt[3]{\frac{a}{2k}}$$

NOTE.—Various authorities give the relation of horsepower as proportional to the cube of the speed, and as horsepower varies directly as the fuel consumption, then the fuel consumption also varies in direct proportion to the cube of the speed.

A nautical mile (knot) equals 1.15155 U. S. statute miles and equals the length of 1' of arc on a circle of diameter of the earth.

EXAMPLE 4.—The strength of a rectangular beam is proportional to the width and to the square of the depth. Find the dimensions of the strongest beam that can be cut from a round log 24 inches in diameter.

Let  $S$  = strength of the beam.

$x$  = its width.

$y$  = its depth.

Then

$$S = kxy^2.$$

From the triangle (Fig. 567),

$$x^2 + y^2 = (24)^2 = 576.$$

$$y^2 = 576 - x^2.$$

Then

$$S = kx(576 - x^2).$$

$$\frac{dS}{dx} = 576k - 3kx^2.$$

$$\frac{d^2S}{dx^2} = -6kx.$$

$$\frac{dS}{dx} = 0, \text{ and } \frac{d^2S}{dx^2} = \text{a negative number when}$$

$$3kx^2 = 576k.$$

$$x^2 = 192.$$

$$x = 13.86.$$

$$y = 19.60.$$

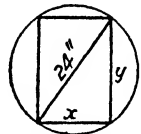

FIG. 567.

EXAMPLE 5.—From mechanics we are given the following relations in a belt drive:

$$\text{Centrifugal tension} = C = \frac{wv^2}{g},$$

where  $w$  is the weight of 1 foot of belt of 1 square inch in section. If  $T_2$  is the greatest tension on the tight side that the belt should take, then the effective tension  $F$  for the transmission of power is

$$F = T_2 - \frac{wv^2}{g}$$

The power transmitted per square inch of belt section is

$$P = Fv.$$

Then

$$P = T_2v - \frac{wv^3}{g}$$

To find the maximum power, equate the first derivative to zero.

$$\frac{dP}{dv} = T_2 - \frac{3wv^2}{g}$$

$$\therefore \frac{3wv^2}{g} = T_2.$$

But  $\frac{wv^2}{g} = C$ , the centrifugal tension. Then

$$3C = T_2.$$

$$C = \frac{T_2}{3}.$$

The maximum power results when the centrifugal tension is one-third the greatest permissible working tension in the belt.

EXAMPLE 6.—What velocity will give a maximum power for a chain drive having a working load  $P$ , when the centrifugal force is considered.

Let  $w$  = the weight of the chain per foot.

$v$  = the velocity of the chain in feet per second.

$g = 32.17$ .

The centrifugal tension is  $C = \frac{wv^2}{g}$ .

If  $T_2$  is the greatest permissible working load for the chain, the effective tension  $F$  for the transmission of power is

$$F = T_2 - \frac{wv^2}{g},$$

and the power transmitted, as in the previous example, is

$$P = T_2v - \frac{wv^3}{g}$$

$$\frac{dP}{dv} = T_2 - \frac{3wv^2}{g}$$

The maximum velocity that the chain should run is

$$v = \sqrt{\frac{T_2 g}{3w}}$$

Let us take an example of a very common commercial chain, as No. 103 malleable, and see what happens.



$$w = 4 \text{ pounds per foot.}$$

$$T_2 = 1000 \text{ pounds.}$$

$$v = \sqrt{\frac{1000 \times 32.17}{3 \times 4}} = 51.77 \text{ feet per second.}$$

It is not good practice to run this chain over 10 feet per second due to the tooth action and other reasons. It is, therefore, quite evident that the centrifugal force does not become a factor to affect the strength of the chain but enters into the problem only when there is considerable slack in the chain causing it to jump the teeth of the sprocket wheel.

**974. Curvature.**—Consider an arc concave toward its chord for its full length. The amount that the arc is bent can be measured by the angle  $\beta$  between the tangents at its ends or the amount that the tangent rotates as the point of tangency moves along the curve from one end of the arc to the other.

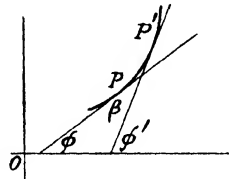

FIG. 568.

The ratio  $\frac{\beta}{\text{arc } PP'} = \frac{\phi' - \phi}{\Delta s}, \frac{\Delta\phi}{\Delta s}$  is the *average* bending per unit length along  $PP'$ . As  $P$  approaches  $P'$ , or  $\Delta s \rightarrow 0$ ,

$$\text{Limit}_{\Delta s \rightarrow 0} \frac{\Delta\phi}{\Delta s} = \frac{d\phi}{ds},$$

which is called the *curvature* at  $P$ . It will be noted that the curvature varies directly as the sharpness of the bend; that is, the curvature is greater where the curve bends more sharply and less where the curve is straighter.

**EXAMPLE.**—Find the curvature for a point  $P$  on a circle of radius  $a$ .

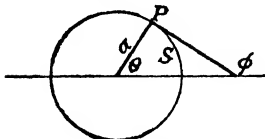

FIG. 569.

$$\phi = \theta + \frac{\pi}{2}.$$

$$s = a\theta.$$

Then

$$\frac{d\phi}{ds} = \frac{d\theta}{a \cdot d\theta} = \frac{1}{a}.$$

The curvature of a circle is constant and equal to the reciprocal of its radius, or the curvature varies inversely as the radius. For this reason the radius is not used to measure curvature since it does not vary directly as the radius.

**975. Radius of Curvature.**—In the previous article, we found that the radius of a circle is the reciprocal of its curvature.

The radius of curvature of a curve at any point is defined as the radius of the circle which has the same curvature as the curve at the point in question and is, therefore, the reciprocal of the curvature, or

$$[563] \quad \rho = \frac{1}{\frac{d\varphi}{ds}} = \frac{ds}{d\varphi}. \quad (1)$$

$$\text{Now } \varphi = \tan^{-1} \frac{dy}{dx}.$$

From Art. 949 [520],

$$d\varphi = \frac{d\left(\frac{dy}{dx}\right)}{1 + \left(\frac{dy}{dx}\right)^2} = \frac{\frac{d^2y}{dx^2} \cdot dx}{1 + \left(\frac{dy}{dx}\right)^2} \quad (2)$$

$$\text{But} \quad ds = \sqrt{(dx)^2 + (dy)^2}. \quad (3)$$

Substituting (2) and (3) in (1),

$$[564] \quad \rho = \frac{ds}{d\varphi} = \frac{\left[1 + \left(\frac{dy}{dx}\right)^2\right]^{\frac{3}{2}}}{\frac{d^2y}{dx^2}}.$$

Since the numerical value of  $\rho$  is usually desired, its sign can be disregarded.

In a manner similar to that used, the relation,

$$[565] \quad \rho = \frac{\left[1 + \left(\frac{dx}{dy}\right)^2\right]^{\frac{3}{2}}}{\frac{d^2x}{dy^2}},$$

can be shown to hold when the curve is given in the form,  $x = f(y)$ .

EXAMPLE.—Find radius of curvature of parabola  $y^2 = 4x$  at the point (9, 6).

$$\begin{aligned} \frac{dy}{dx} &= \frac{2}{y} = \frac{2}{6} = \frac{1}{3}. \\ \frac{2}{y} &= 2y^{-1}. \\ \frac{d^2y}{dx^2} &= \frac{d(2y^{-1})}{dx} = -2 \cdot y^{-2} \cdot \frac{dy}{dx} = -\frac{4}{y^3} = -\frac{1}{54}. \\ \rho &= \frac{\left[1 + \left(\frac{dy}{dx}\right)^2\right]^{\frac{3}{2}}}{\frac{d^2y}{dx^2}} = \frac{\left(1 + \frac{1}{9}\right)^{\frac{3}{2}}}{-\frac{1}{54}} = -63.23. \end{aligned}$$

## CHAPTER XLIX

### EXPANSION OF FUNCTIONS

**976. Rolle's Theorem.**—If  $f(x)$  and its derivative  $f'(x)$  are single valued and continuous for all values of  $x$  from  $x = a$  to  $x = b$ , and if  $f(a) = f(b) = 0$ , then  $f'(x)$  vanishes for at least one value of  $x$  between  $a$  and  $b$ .

Geometrically, if a continuous curve cuts the  $X$ -axis in two points,  $x = a$  and  $x = b$ , and has a finite slope at every point in this interval, then at some point, say  $x = x_0$ ,  $a < x_0 < b$ , the tangent to the curve is parallel to the  $X$ -axis.

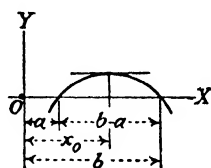

FIG. 570.

**977. The Law of the Mean.**—The law of the mean, sometimes called the mean value theorem, is deduced from Rolle's theorem and is as follows:

If  $f(x)$  and its first derivative  $f'(x)$  are continuous from  $x = a$  to  $x = b$ , there is a value  $x = x_1$  between  $x = a$  and  $x = b$ , such that

$$[566] \quad \frac{f(b) - f(a)}{b - a} = f'(x_1),$$

or 
$$f(b) = f(a) + (b - a)(f'[x_1]). \quad (1)$$

Let

$$\frac{f(b) - f(a)}{b - a} = Q.$$

Since  $a$  and  $b$  are constants,  $Q$  is a constant, and

$$f(b) - f(a) - (b - a)Q = 0. \quad (2)$$

Let  $\varphi(x)$  be a function built up by replacing  $a$  by  $x$  in (2).

$$\varphi(x) = f(b) - f(x) - (b - x)Q, \quad (3)$$

and

$$\varphi'(x) = -f'(x) + Q. \quad (4)$$

Since  $f(x)$  and  $f'(x)$  are continuous between  $x = a$  and  $x = b$ ,  $\varphi(x)$  and  $\varphi'(x)$  are also continuous between  $x = a$  and  $x = b$ .

From (2),

$$(b - a)Q = f(b) - f(a),$$

which substituted in (3) gives

$$\varphi(x) = f(b) - f(x) - f(b) + f(a) = f(a) - f(x).$$

Then

$$\varphi(a) = f(a) - f(a) = 0.$$

Also from (3),

$$\varphi(b) = f(b) - f(b) - (b - b)Q = 0.$$

Hence,  $\varphi(x)$  satisfies the conditions of Rolle's theorem (Art. 976) and consequently,

$$\varphi'(x_1) = 0,$$

and (4) becomes

$$0 = -f'(x_1) + Q,$$

or

$$Q = f'(x_1),$$

where  $x_1$  is between  $x = a$  and  $x = b$ .

Substituting in (2),

$$f(b) = f(a) + (b - a)f'(x_1),$$

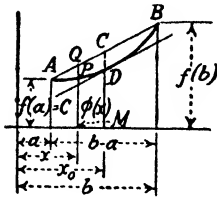

FIG. 571.

which was to be proved.

**978. The Extended Law of the Mean.**—If  $f(x)$  be a function which with its first and second derivatives  $f'(x)$  and  $f''(x)$  is continuous from  $x = a$  to  $x = b$ , then there is a value  $x = x_2$  between  $x = a$  and  $x = b$ , such that

$$f(b) = f(a) + (b - a)f'(a) + \frac{(b - a)^2}{2}f''(x_2). \quad (1)$$

Let

$$\frac{f(b) - f(a) - (b - a)f'(a)}{\frac{(b - a)^2}{2}} = R.$$

Since  $a$  and  $b$  are constants,  $R$  is a constant, and

$$f(b) - f(a) - (b - a)f'(a) - \frac{(b - a)^2}{2}R = 0 \quad (2)$$

From the left member of the equation, form the function  $\varphi_2(x)$  by replacing  $a$  by  $x$ . Then

$$\varphi_2(x) = f(b) - f(x) - (b - x)f'(x) - \frac{(b - x)^2}{2}R. \quad (3)$$

Differentiating, remembering that the third term is a product,

$$\begin{aligned} \varphi_2'(x) &= -f'(x) - (b - x)f''(x) + f'(x) + (b - x)R. \\ &= (b - x_2)(R - f''[x]). \end{aligned} \quad (4)$$

Since  $f(x)$ ,  $f'(x)$ , and  $f''(x)$  are continuous,  $\varphi_2(x)$  and  $\varphi_2'(x)$  are continuous.

From (2),

$$\frac{(b-a)^2}{2}R = f(b) - f(a) - (b-a)f'(a),$$

which substituted in (3) gives

$$\varphi_2(x) = f(b) - f(x) - (b-x)f'(x) - f(b) + f(a) + (b-a)f'(a).$$

$$\varphi_2(a) = f(a) - (b-a)f'(a) - f(a) + (b-a)f'(a) = 0.$$

Also from (3),

$$\varphi_2(b) = f(b) - f(b) - (b-b)f'(b) - \frac{(b-b)^2}{2}R = 0.$$

Hence, the conditions of Rolle's theorem are satisfied and

$$\varphi_2'(x_2) = 0,$$

and (4) becomes

$$0 = (b-x_2)[R - f''(x_2)],$$

or

$$R = f''(x_2),$$

which substituted in (2) gives

$$f(b) = f(a) + (b-a)f'(a) + \frac{(b-a)^2}{2}f''(x_2),$$

which was to be proved.

This same process may be continued in a similar manner to show that

$$f(b) = f(a) + (b-a)f'(a) + \frac{(b-a)^2}{2}f''(a) + \frac{(b-a)^3}{3}f'''(x_3),$$

and in general,

$$\begin{aligned} [567] \quad f(b) = & f(a) + (b-a)f'(a) + \frac{(b-a)^2}{2}f''(a) + \\ & \frac{(b-a)^3}{3}f'''(a) + \dots + \frac{(b-a)^{n-1}}{(n-1)}f^{n-1}(a) + \frac{(b-a)^n}{n}f^n(x_n), \end{aligned}$$

where  $a < x_n < b$ , which is the general form of the extended theorem of the mean.

**979. Taylor's Theorem with the Remainder.**—If  $b$  is replaced by  $x$  in the general form of the extended theorem of the mean value (Art. 978), then

$$\begin{aligned} [568] \quad f(x) = & f(a) + \frac{(x-a)}{1}f'(a) + \frac{(x-a)^2}{2}f''(a) + \\ & \frac{(x-a)^3}{3}f'''(a) + \dots + \frac{(x-a)^{n-1}}{(n-1)}f^{n-1}(a) + \frac{(x-a)^n}{n}f^n(x_n), \end{aligned}$$

which is called Taylor's theorem or Taylor's series.

This expansion holds true for all values of  $x$  from  $x = a$  to  $x = b$  provided that the function and its first  $n$  derivatives are finite and continuous throughout the interval from  $x = a$  to  $x = b$ . If  $x$  is substituted for  $b$ , we have an expression which holds between the limits.

The finite series in  $(x - a)$  may be substituted for the function  $f(x)$ .

The last term,  $\frac{(x - a)^n}{n!} f^n(x_n)$ , is called the *remainder*. If this remainder can be made as small as we please by taking  $n$  sufficiently large, the series becomes an infinite series which is convergent and which converges to the value  $f(x)$ . For those values of  $x$  for which the remainder approaches the limit, zero, or

$$\lim_{n \rightarrow \infty} \left[ \frac{(x - a)^n}{n!} f^n(x_n) \right] = 0,$$

the function is equal to the sum of the convergent series.

EXAMPLE.—Develop  $\sin x$  into a power series in  $(x - a)$ .

$$\begin{array}{ll} f(x) = \sin x. & \text{Then } f(a) = \sin a. \\ f'(x) = \cos x. & \text{Then } f'(a) = \cos a. \\ f''(x) = -\sin x. & \text{Then } f''(a) = -\sin a. \\ f'''(x) = -\cos x. & \text{Then } f'''(a) = -\cos a. \\ f^{iv}(x) = \sin x. & \text{Then } f^{iv}(a) = \sin a. \\ f^v(x) = \cos x. & \text{Then } f^v(a) = \cos a. \end{array}$$

Then substituting in [568],

$$\begin{aligned} \sin x = \sin a + \cos a(x - a) - \sin a \frac{(x - a)^2}{2} - \cos a \frac{(x - a)^3}{6} \\ + \sin a \frac{(x - a)^4}{24} + \cos a \frac{(x - a)^5}{120} \end{aligned}$$

If we replace  $(x)$  by  $(a + h)$  in [568], we get still another form of Taylor's series, namely,

$$\begin{aligned} [569] \quad f(a + h) = f(a) + \frac{h}{1!} f'(a) + \frac{h^2}{2!} f''(a) + \frac{h^3}{3!} f'''(a) + \\ \frac{h^4}{4!} f^{iv}(a) + \dots + \frac{h^{n-1}}{(n-1)!} f^{n-1}(a) + \frac{h^n}{n!} f^n(a) + \dots \end{aligned}$$

This series is particularly useful when it is desired to express a function of the sum of two numbers as a power series in one of them.

Let

$$y = f(x) = ax^3 + bx^2 + cx + d.$$

If  $x$  receives an increment  $h$ , then

$$f(x+h) = f(x) + f'(x)h + \frac{f''(x)}{2}h^2 + \frac{f'''(x)}{3}h^3 + \dots$$

Differentiating,

$$f'(x) = 3ax^2 + 2bx + c.$$

$$f''(x) = 6ax + 2b. \quad \frac{f''(x)}{2} = 3ax + b.$$

$$f'''(x) = 6a. \quad \frac{f'''(x)}{3} = a.$$

$$f^{iv}(x) = 0.$$

Substituting,

$$f(x+h) = (ax^3 + bx^2 + cx + d) + (3ax^2 + 2bx + c)h + (3ax + b)h^2 + ah^3.$$

This is a much easier method to follow in most cases than that of substituting  $x+h$  for  $x$  in the equation which defines the function, and then performing the algebraic operation of multiplication, indicated in

$$f(x+h) = a(x+h)^3 + b(x+h)^2 + c(x+h) + d.$$

**980. Maclaurin's Theorem with the Remainder.**—This is a special form of Taylor's theorem where  $a = 0$ . The function  $f(x)$  and its first  $n$  derivatives are continuous from  $x = 0$  to  $x = a$ . The series then becomes

$$[570] \quad f(x) = f(0) + f'(0)x + f''(0)\frac{x^2}{2} + f'''(0)\frac{x^3}{3} + f^{iv}(0)\frac{x^4}{4} + \dots + f^{n-1}(0)\frac{x^{n-1}}{(n-1)} + f^n(x_1)\frac{x^n}{n}.$$

This is known as Maclaurin's series.

EXAMPLE.—Find a series for  $\cos x$ .

$$\text{Then } f(x) = \cos x = f(0) + f'(0)x + \frac{f''(0)x^2}{2} + \frac{f'''(0)x^3}{3} + \dots$$

$$f(0) = \cos 0 = 1. \quad \text{First term} = 1.$$

$$f'(x) = \frac{d(\cos x)}{dx} = -\sin x. \quad \text{Then}$$

$$f'(0) = -\sin 0 = 0. \quad \text{Second term} = 0 \cdot x = 0.$$

$$f''(x) = \frac{d(-\sin x)}{dx} = -\cos x. \quad \text{Then}$$

$$f''(0) = -\cos 0 = -1. \quad \text{Third term} = \frac{-1 \cdot x^2}{2} = \frac{-x^2}{2}.$$

$$f'''(x) = \frac{d(-\cos x)}{dx} = \sin x. \quad \text{Then}$$

$$f'''(0) = \sin 0 = 0. \quad \text{Fourth term} = \frac{0 \cdot x^3}{|3|} = 0.$$

$$f^{iv}(x) = \frac{d(\sin x)}{dx} = \cos x. \quad \text{Then}$$

$$f^{iv}(0) = \cos 0 = 1. \quad \text{Fifth term} = \frac{1 \cdot x^4}{|4|} = \frac{x^4}{4}.$$

Writing the series,

$$[571] \quad \cos x = 1 - \frac{x^2}{|2|} + \frac{x^4}{|4|} - \frac{x^6}{|6|} + \frac{x^8}{|8|} - \dots$$

EXAMPLE.—Find a series for  $\sin x$ .

$$\text{Let } f(x) = \sin x. \quad \text{Then } f(0) = \sin 0 = 0.$$

$$f'(x) = \cos x. \quad \text{Then } f'(0) = \cos 0 = 1.$$

$$f''(x) = -\sin x. \quad \text{Then } f''(0) = -\sin 0 = 0.$$

$$f'''(x) = -\cos x. \quad \text{Then } f'''(0) = -\cos 0 = -1.$$

Our series is

$$[572] \quad \sin x = x - \frac{x^3}{|3|} + \frac{x^5}{|5|} - \frac{x^7}{|7|} + \frac{x^9}{|9|} - \dots$$

Also,

$$[573] \quad i(\sin x) = i\left(x - \frac{x^3}{|3|} + \frac{x^5}{|5|} - \dots\right).$$

EXAMPLE.—Find series for  $\cos x + i \sin x$ . From the series found for  $\cos x$  and for  $i \sin x$ ,

$$[574] \quad \cos x + i \sin x = \left(1 - \frac{x^2}{|2|} + \frac{x^4}{|4|} - \frac{x^6}{|6|} + \dots\right) +$$

$$i\left(x - \frac{x^3}{|3|} + \frac{x^5}{|5|} - \frac{x^7}{|7|} + \dots\right).$$

$$= 1 + ix - \frac{x^2}{|2|} + \frac{ix^3}{|3|} - \frac{x^4}{|4|} + \dots$$

$$= 1 + ix + \frac{i^2x^2}{|2|} + \frac{i^3x^3}{|3|} + \frac{i^4x^4}{|4|} + \dots$$

EXAMPLE.—Find a series for  $\log_e(1+x)$ .

$$\text{Let } f(x) = \log_e(1+x). \quad \text{Then } f(0) = \log_e 1 = 0.$$

$$f'(x) = \frac{1}{1+x}. \quad \text{Then } f'(0) = 1.$$

$$f''(x) = \frac{-1}{(1+x)^2}. \quad \text{Then } f''(0) = \frac{-1}{1} = -1.$$

$$f'''(x) = \frac{2}{(1+x)^3}. \quad \text{Then } f'''(0) = \frac{2}{1} = 2.$$

Substitute in

$$f(x) = f(0) + f'(0) \cdot x + f''(0) \frac{x^2}{|2|} + f'''(0) \frac{x^3}{|3|} + \dots \quad [570]$$



[575]  $\log_e (1 + x) = x - \frac{x^2}{2} + \frac{x^3}{3} - \frac{x^4}{4} + \dots$

For series for  $\log_e (1 - x)$ , substitute  $-x$  for  $x$ , and we have

[576]  $\log_e (1 - x) = -x - \frac{x^2}{2} - \frac{x^3}{3} - \frac{x^4}{4} - \dots$

The fact that all of the terms are negative agrees with the fact that all logs of numbers less than unity are negative.

EXAMPLE.—Find a series for  $e^{ix}$ .

$f(x) = e^{ix}$ . Then  $f(0) = e^0 = 1$ .

$f'(x) = ie^{ix}$ . Then  $f'(0) = ie^0 = i = \sqrt{-1}$ .

$f''(x) = i^2 e^{ix}$ . Then  $f''(0) = i^2 e^0 = i^2 = -1$ .

$f'''(x) = i^3 e^{ix}$ . Then  $f'''(0) = i^3 e^0 = i^3 = -\sqrt{-1}$ .

Hence,

[577]  $e^{ix} = 1 + ix + \frac{i^2 x^2}{2} + \frac{i^3 x^3}{3} + \frac{i^4 x^4}{4} + \dots$

But this is the same series as we found for  $\cos x + i \sin x$ . Therefore,

[578]  $e^{ix} = \cos x + i \sin x$ .

981. Limit of  $\frac{\sin x}{x}$  as  $x$  Approaches 0.—This limit was shown in Art. 936 to be unity. This fact can also be shown by developing a series, thus,

$$\begin{aligned} \frac{\sin x}{x} &= \frac{x - \frac{x^3}{3} + \frac{x^5}{5} - \frac{x^7}{7} + \dots}{x} \\ &= 1 - \frac{x^2}{3} + \frac{x^4}{5} - \frac{x^6}{7} + \dots \end{aligned}$$

It is easily seen from the above that when  $x$  approaches 0 the series approaches unity as a limit for its sum. Therefore,

[579]  $\lim_{x \rightarrow 0} \left[ \frac{\sin x}{x} \right] = 1$ .

982. Indeterminate Forms.—The principal indeterminate forms are

$$\frac{0}{0}, \frac{\infty}{\infty}, 0 \cdot \infty, \infty - \infty.$$

The form  $\frac{0}{0}$  occurs quite frequently while the forms  $\frac{\infty}{\infty}$  and  $0 \cdot \infty$  may be transformed into the form  $\frac{0}{0}$ .

Any fraction, as  $\frac{A}{B}$ , may be written in the form,

$$\frac{1}{\frac{1}{\frac{A}{B}}}$$

If, now,  $A$  and  $B$  increase without bound,  $\frac{1}{A}$  and  $\frac{1}{B}$  approach 0 and the indeterminate form becomes  $\frac{0}{0}$ .

Also, if in a product  $AB$  one of the factors, as  $A$ , approaches zero and the other,  $B$ , increases without bound, we may write the product in the form,

$$\frac{A}{\frac{1}{B}}$$

which is also in the form  $\frac{0}{0}$ .

It is necessary, then, to find the limit of a fraction when its numerator and denominator both approach zero.

Consider the fraction  $\frac{f(x)}{\varphi(x)}$ .

Assume that for some value of  $x$ , called the *critical value*, the fraction assumes the form,  $\frac{0}{0}$ .

For any other value of  $x$  the fraction will have a definite value which may be determined by the substitution of the value of  $x$ .

We seek to determine the limit which the fraction approaches as the value of  $x$  approaches the critical value.

Assume that both  $f(x)$  and  $\varphi(x)$  become zero when  $x = a$ . Then

$$f(a) = 0 \text{ and } \varphi(a) = 0,$$

and  $a$  is a critical value of  $x$ .

By Taylor's theorem,

$$f(a + h) = f(a) + f'(a)h + \frac{f''(a)h^2}{2} + \frac{f'''(a)h^3}{3} + \dots$$

$$\varphi(a + h) = \varphi(a) + \varphi'(a)h + \frac{\varphi''(a)h^2}{2} + \frac{\varphi'''(a)h^3}{3} + \dots$$

[569]

But  $f(a) = 0$  and  $\varphi(a) = 0$ . Then

$$\begin{aligned} \frac{f(a+h)}{\varphi(a+h)} &= \frac{f'(a)h + \frac{f''(a)}{2}h^2 + \frac{f'''(a)}{3}h^3 + \dots}{\varphi'(a)h + \frac{\varphi''(a)}{2}h^2 + \frac{\varphi'''(a)}{3}h^3 + \dots} \\ &= \frac{f'(a) + \frac{f''(a)}{2}h + \frac{f'''(a)}{3}h^2 + \dots}{\varphi'(a) + \frac{\varphi''(a)}{2}h + \frac{\varphi'''(a)}{3}h^2 + \dots} \end{aligned}$$

If  $h$  approaches zero, in which case the Taylor's series converges, then

[580] 
$$\lim_{x \rightarrow a} \left( \frac{f(x)}{\varphi(x)} \right) = \frac{f'(a)}{\varphi'(a)}$$

We can, therefore, find the required limit of the fraction by simply substituting for the numerator and denominator their first derivatives with respect to  $x$ , and then substituting the values of these derivatives when  $x = a$ .

EXAMPLE.—Find, by above method,

$$\lim_{x \rightarrow 3} \left[ \frac{x^2 - 9}{x - 3} \right].$$

If 3 is substituted for  $x$ , then

$$\frac{9 - 9}{3 - 3} = \frac{0}{0}$$

Differentiating,

$$\frac{\frac{d(x^2 - 9)}{dx}}{\frac{d(x - 3)}{dx}} = \frac{2x}{1} = \frac{2 \cdot 3}{1} = 6.$$

Therefore, the limit of the fraction as  $x \rightarrow 3$  is 6.

EXAMPLE.—Find

$$\lim_{x \rightarrow 0} \left[ \frac{x^3 + 6x^2}{3x^3 + x^2} \right].$$

Differentiating,

$$\frac{f'(x)}{\varphi'(x)} = \frac{3x^2 + 12x}{9x^2 + 2x}$$

When  $x = 0$  is substituted, the fraction still takes the indeterminate form  $\frac{0}{0}$ . We differentiate again and there results

$$\frac{f''(x)}{\varphi''(x)} = \frac{12x^2 + 12}{18x + 2}$$

Substituting  $x = 0$ , we have

$$\text{Limit}_{x \rightarrow 0} \left[ \frac{f''(x)}{\varphi''(x)} \right] = \text{Limit}_{x \rightarrow 0} \left[ \frac{f(x)}{\varphi(x)} \right] = \frac{12}{2} = 6.$$

Therefore,

$$\text{Limit}_{x \rightarrow 0} \left[ \frac{x^4 + 6x^2}{3x^3 + x^2} \right] = 6.$$

EXAMPLE.—Find

$$\text{Limit}_{x \rightarrow \pi} \left[ x - \pi \right] \tan \frac{x}{2} = \text{Limit}_{x \rightarrow \pi} \left[ \frac{x - \pi}{\cot \frac{x}{2}} \right].$$

Differentiate the numerator for a new numerator and the denominator for a new denominator.

$$\frac{d(x - \pi)}{dx} = 1. \quad \frac{d\left(\cot \frac{x}{2}\right)}{dx} = -\frac{1}{2} \csc^2 \frac{x}{2}.$$

$$\text{Limit}_{x \rightarrow \pi} \left[ \frac{1}{-\frac{1}{2} \csc^2 \frac{x}{2}} \right] = -2.$$

## CHAPTER I

### PARTIAL AND TOTAL DIFFERENTIATION

**983. Functions of Two Independent Variables.**—Heretofore, we have considered functions of a single independent variable. We have considered functions, such as  $y = uv$  and  $u = xy$ , but in the former,  $u$  and  $v$  were both functions of a single independent variable  $x$ , and in the latter,  $x$  and  $y$  were usually used to indicate functions of the independent variable  $t$ .

In the case that we are about to consider, that of two independent variables, there is no single independent variable upon which the value of the function is dependent. Thus, the volume of a gas depends upon the temperature and also upon the pressure to which it is subjected, but the temperature and the pressure may vary independently.

**984. Differentiation of Functions of Two Independent Variables.**—In a function  $f(x, y)$  of two independent variables, there are three relations between the function and the variables that we desire to examine. We wish to determine the manner in which the function varies as  $x$  varies and  $y$  remains constant, the manner in which the function varies as  $y$  varies and  $x$  remains constant, and the manner in which the function varies when both  $x$  and  $y$  vary.

Let the function  $f(x, y)$  of the independent variable be represented by the equation,

$$z = f(x, y),$$

which according to solid analytical geometry (Art. 840) is an equation of a surface. If only one of the independent variables is considered to vary and the other to remain constant, the derivative is called a *partial derivative*.

In this case the process is the same as previous cases of differentiation of a single variable, and the equation,  $z = f(x, y)$ , is represented graphically by a plane curve formed by an intersecting plane parallel to a coordinate plane.

In the first case, if  $y$  is given a constant value  $y_0$  and  $x$  is considered to vary, then for any value of  $x$ , as  $x_0$ ,

$$\Delta_x z = f(x_0 + \Delta x, y_0) - f(x_0, y_0),$$

and

$$\text{Limit}_{\Delta x \rightarrow 0} \left[ \frac{\Delta_x z}{\Delta x} \right] = \frac{\partial z}{\partial x},$$

where the subscript  $x$  denotes that  $x$  is the independent variable and  $\frac{\partial z}{\partial x}$  is a symbol indicating a partial derivative.

To illustrate geometrically, let  $P$  be a point on the curve formed by the intersecting plane  $y = y_0$  and the surface  $z = f(x, y)$

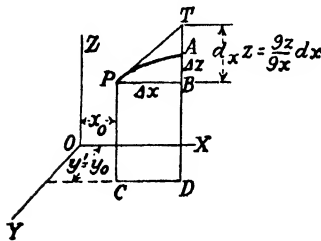

FIG. 572.

at  $x_0$  distance from the  $YZ$ -plane as shown in Fig. 572. Assume another point  $A$  on the curve and drop perpendiculars  $PC$  and  $TAD$  to the  $XY$ -plane, intersecting the  $XY$ -plane at  $C$  and  $D$ . Call  $CD$  equal to  $\Delta x$ . Draw  $PB$  parallel to  $CD$ . Draw  $PT$  tangent to the curve at point  $P$ . Then  $AB$  geometrically represents  $\Delta_x z$ , and  $TB$  represents  $dz = \frac{dz}{dx} dx$  from Art. 960 but becomes  $d_x z = \frac{\partial z}{\partial x} dx$  when the new symbols are used.

In the same manner, if  $x$  is given a constant value  $x_0$  and  $y$  is considered to vary, then for any value of  $y$ , as  $y_0$ ,

$$\Delta_y z = f(x_0, y_0 + \Delta y) - f(x_0, y_0).$$

and

$$\text{Limit}_{\Delta y \rightarrow 0} \frac{\Delta_y z}{\Delta y} = \frac{\partial z}{\partial y}.$$

To illustrate geometrically, pass an intersecting plane  $x = x_0$  through any point  $P$  on the curve formed by the intersecting plane and the surface  $z = f(x, y)$  at  $x_0$  distance from, and parallel to, the  $YZ$ -plane, as shown in Fig. 573. Assume another point  $A'$  on the intersecting curve, and draw  $PD'$  and

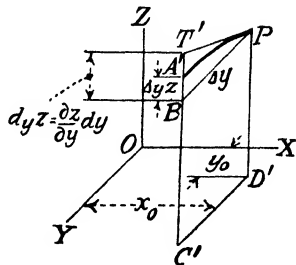

FIG. 573.

$T'A'C'$  perpendicular to and intersecting the  $XY$ -plane at  $C'$  and  $D'$ . Draw  $PB'$  parallel to  $C'D'$ . Let  $C'D' = \Delta y$ . Draw  $P'T'$  tangent to the curve at point  $P$ . Then  $A'B'$  geometrically represents  $\Delta_y z$  and  $T'B'$  represents  $d_y z = \frac{\partial z}{\partial y} dy$ .

**985. Total Differentiation.**—The case remaining to be considered is the case where  $x$  and  $y$  are varying simultaneously but independent of each other.

Let  $x = x_0$  and  $y = y_0$  as before, and denote the intersection of the two planes and the surface  $z = f(xy)$  by the point  $P_0(x_0, y_0, z_0)$ . Let  $x$  take an increment  $\Delta x = dx$ , and  $y$  take an increment  $\Delta y = dy$ , and let  $L$  be the point on the surface at  $x_0 + \Delta x, y_0 + \Delta y, z_0 + \Delta z$ . From Fig. 574,  $CD = dx$ ,  $CC' = dy$ .

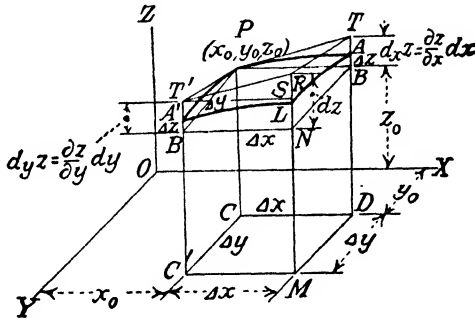

FIG. 574.

Let  $P_0TT'R$  be the plane tangent to the surface at the point  $P_0$ . Then  $P_0T$  is tangent to the arc  $P_0A$ , and  $P_0T'$  is tangent to the arc  $P_0A'$ . The plane  $P_0TT'R$  satisfies the condition of variation of the function as  $x$  varies, since it contains the tangent  $P_0T$ , and it satisfies the condition of variation as  $y$  varies, since it contains the tangent  $P_0T'$ . Also,  $RN$  represents the increment  $dz$  measured to the tangent plane when  $x$  and  $y$  are given the increments  $dx$  and  $dy$ .

Draw  $T'S$  parallel to  $XY$ -plane. Then the triangles  $RT'S$  and  $TP_0B$  are equal, and  $RS = TB$ .

Then

$$RN = RS + SN.$$

But

$$RN = dz, RS = \frac{\partial z}{\partial x} dx, SN = TB = \frac{\partial z}{\partial y} dy.$$

Substituting,

$$[581] \quad dz = \frac{\partial z}{\partial x} dx + \frac{\partial z}{\partial y} dy.$$

The differential of a function of two independent variables is equal to the sum of all the products formed by multiplying the partial derivatives of the function with respect to each independent variable by the differential of that variable.

This rule applies to functions of any number of independent variables. Thus,

$$du = \frac{\partial u}{\partial x} dx + \frac{\partial u}{\partial y} dy + \frac{\partial u}{\partial z} dz.$$

When the independent variables are functions of a single independent variable, as  $t$ , we may form the total derivative of the function with respect to the single independent variable, thus:

Dividing the above equation by  $dt$ ,

$$\frac{du}{dt} = \frac{\partial u}{\partial x} \cdot \frac{dx}{dt} + \frac{\partial u}{\partial y} \cdot \frac{dy}{dt} + \frac{\partial u}{\partial z} \cdot \frac{dz}{dt}.$$

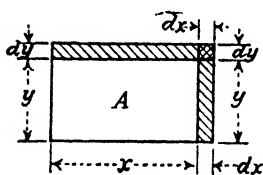

FIG. 575.

EXAMPLE.—A dam across a valley forms a rectangular lake, 2000 feet wide and 5000 feet long. A storm causes the width of the lake to increase at the rate of 50 feet per minute and the length to increase at the rate of 200 feet per minute. At what rate is the area of the lake increasing 10 minutes after the storm starts?

Let  $x$  = the width of the lake.

$y$  = the length of the lake.

$z$  = the area.

$$z = xy.$$

$$\frac{dz}{dt} = \frac{\partial z}{\partial x} \frac{dx}{dt} + \frac{\partial z}{\partial y} \frac{dy}{dt}.$$

$$\frac{\partial z}{\partial x} = y, \frac{dx}{dt} = 50, \frac{\partial z}{\partial y} = x, \frac{dy}{dt} = 200.$$

$$y_0 = 5000 + 200 \times 10 = 7000, x_0 = 2000 + 50 \times 10 = 2500.$$

$$\frac{dz}{dt} = y_0 \times 50 + x_0 \times 200.$$

$$= 7000 \times 50 + 2500 \times 200.$$

$$= 850,000 \text{ square feet per minute.}$$



**986. Differentiation of a Function of a Function of Two or More Independent Variables.**—This differentiation takes the form of the total derivative as developed in the preceding article. If  $u = f(x, y)$  and if  $x$  and  $y$  are independent of each other but each variable is a function of another variable  $t$ , then

$$du = \frac{\partial u}{\partial x} dx + \frac{\partial u}{\partial y} dy.$$

Dividing by  $dt$ ,

$$[582] \quad \frac{du}{dt} = \frac{\partial u}{\partial x} \cdot \frac{dx}{dt} + \frac{\partial u}{\partial y} \cdot \frac{dy}{dt},$$

in which the total derivative  $\frac{du}{dt}$  is the time rate of change of the function  $u$ .

In the same manner if  $u = f(x, y, z)$  and if  $x, y$ , and  $z$  are independent of each other but are all functions of  $t$ ,

$$[583] \quad \frac{du}{dt} = \frac{\partial u}{\partial x} \cdot \frac{dx}{dt} + \frac{\partial u}{\partial y} \cdot \frac{dy}{dt} + \frac{\partial u}{\partial z} \cdot \frac{dz}{dt}$$

EXAMPLE.—Given the formula for a gas,

$$pV = kT,$$

where

$p$  = pressure.

$V$  = volume.

$T$  = temperature.

$k$  = a constant depending on the gas.

Assume  $k = 50$  and let the volume and the temperature at a given time be  $V_0 = 5$  cubic feet,  $T_0 = 250$  degrees. Then

$$5p_0 = 50 \times 250.$$

$$p_0 = 2500 \text{ pounds per square foot.}$$

If the temperature is rising at the rate of .5 degree per minute and the volume is increasing at the rate of .2 cubic foot per minute, at what rate is the pressure changing?

Since  $p$  is a function of the other variables, we will write the equation in the form,

$$p = 50 \frac{T}{V}.$$

But

$$\begin{aligned} \frac{dp}{dt} &= \frac{\partial p}{\partial T} \cdot \frac{dT}{dt} + \frac{\partial p}{\partial V} \cdot \frac{dV}{dt} & [582] \\ \frac{\partial p}{\partial T} &= \frac{50}{V}, \quad \frac{\partial p}{\partial V} = -\frac{50T}{V^2}. \end{aligned}$$

We are given in the problem,

$\frac{dT}{dt} = .5$ , the rate at which the temperature changes with respect to the time.

$\frac{dV}{dt} = .2$ , the rate at which the volume changes with respect to the time.

Substituting in

$$\frac{dp}{dt} = \frac{\partial p}{\partial T} \cdot \frac{dT}{dt} + \frac{\partial p}{\partial V} \cdot \frac{dV}{dt} = \frac{50}{V}(.5) - \frac{50T}{V^2}(.2).$$

Since we desire the rate at which the pressure changes when  $V = 5$  and  $T = 250$ , then,

$$\frac{dp}{dt} = \frac{50(.5)}{5} - \frac{50(250).2}{25} = 5 - 100 = -95.$$

This means that the pressure is decreasing at the rate of 95 pounds per minute when the volume is 5 cubic feet and the temperature is 250 degrees.

**987. Successive Partial Differentiation.**—If  $z$  is a function of two independent variables  $x$  and  $y$ , then the first two derivatives,  $\frac{\partial z}{\partial x}$  and  $\frac{\partial z}{\partial y}$ , are themselves functions of  $x$  and  $y$ , and each of these derivatives may be differentiated again with respect to  $x$  and  $y$ .

Consider  $z = x^2\sqrt{y}$ .

$$\frac{\partial z}{\partial x} = 2x\sqrt{y}. \quad \frac{\partial z}{\partial y} = \frac{1}{2}x^2y^{-\frac{1}{2}} = \frac{x^2}{2\sqrt{y}}.$$

Each of these derivatives is a function of  $x$  and  $y$ . There will be two partial derivatives of each of these derivatives, one with respect to each variable.

$$\begin{aligned} \frac{\partial(2x\sqrt{y})}{\partial x} &= 2\sqrt{y}. & \frac{\partial(2x\sqrt{y})}{\partial y} &= xy^{-\frac{1}{2}} = \frac{x}{\sqrt{y}}. \\ \frac{\partial\left(\frac{x^2}{2\sqrt{y}}\right)}{\partial x} &= \frac{x}{\sqrt{y}}. & \frac{\partial\left(\frac{x^2}{2\sqrt{y}}\right)}{\partial y} &= -\frac{x^2}{4\sqrt{y}^3}. \end{aligned}$$

The derivative of  $\frac{\partial z}{\partial x}$  with respect to  $x$  is denoted by  $\frac{\partial^2 z}{\partial x^2}$ .

The derivative of  $\frac{\partial z}{\partial x}$  with respect to  $y$  is  $\frac{\partial^2 z}{\partial x \partial y}$ .

The derivative of  $\frac{\partial z}{\partial y}$  with respect to  $x$  is  $\frac{\partial^2 z}{\partial y \partial x}$ .

The derivative of  $\frac{\partial z}{\partial y}$  with respect to  $y$  is  $\frac{\partial^2 z}{\partial y^2}$ .

In all cases where  $z$  is a function of  $x$  and  $y$ , the two second partial derivatives,

$$\frac{\partial^2 z}{\partial x \partial y} \text{ and } \frac{\partial^2 z}{\partial y \partial x},$$

are identical.

**988. Dependent Variables.**—If some of the variables are functions of others, they are called dependent variables.

Consider

$$u = x^2 + y^2 + z^2,$$

and let  $z$  be a function of  $x$  and  $y$ . When  $y$  is constant,  $z$  will be a function of  $x$ , and the partial derivative of  $u$  with respect to  $x$  will be

$$\frac{\partial u}{\partial x} = 2x + 2z \cdot \frac{\partial z}{\partial x}.$$

The partial derivative of  $u$  with respect to  $y$ , when  $x$  is considered constant, will be

$$\frac{\partial u}{\partial y} = 2y + 2z \cdot \frac{\partial z}{\partial y}.$$

If  $z$  is considered constant, then

$$\frac{\partial u}{\partial x} = 2x \text{ and } \frac{\partial u}{\partial y} = 2y.$$

The value of a partial derivative thus depends upon what quantities are kept constant during the differentiation, and the nature of the problem will make clear of what independent variable  $u$  is considered a function.

If  $x$  and  $y$  are not independent but dependent, and their relation is expressed by the equation,

$$y = F(x),$$

or by the equation,

$$\varphi(x, y) = 0,$$

or by the parametric equations,

$$x = F_1(t) \text{ and}$$

$$y = F_2(t),$$

then we know that the motion is restricted in the  $XY$ -plane and, consequently, the value of  $z$  to a particular curve in space given by the intersection of the cylinder,  $\varphi(x, y) = 0$ , and the surface,  $z = f(x, y)$ .

Whenever such a relation exists between  $x$  and  $y$ , we may choose any variable (such that both  $x$  and  $y$  may be expressed

as functions of this variable) as  $t$  or  $x$  itself, and differentiate the function with respect to that variable.

$$du = \frac{\partial u}{\partial x} dx + \frac{\partial u}{\partial y} dy.$$

$$\frac{du}{dt} = \frac{\partial u}{\partial x} \cdot \frac{dx}{dt} + \frac{\partial u}{\partial y} \cdot \frac{dy}{dt}.$$

Differentiating with respect to  $x$ ,

$$[584] \quad \frac{du}{dx} = \frac{\partial u}{\partial x} \cdot \frac{dx}{dx} + \frac{\partial u}{\partial y} \cdot \frac{dy}{dx} = \frac{\partial u}{\partial x} + \frac{\partial u}{\partial y} \cdot \frac{dy}{dx}.$$

Or with respect to  $y$ ,

$$[585] \quad \frac{du}{dy} = \frac{\partial u}{\partial x} \cdot \frac{dx}{dy} + \frac{\partial u}{\partial y} \cdot \frac{dy}{dy} = \frac{\partial u}{\partial x} \cdot \frac{dx}{dy} + \frac{\partial u}{\partial y}.$$

In the same manner, if

$$u = f(x, y, z),$$

from Art. 986,

$$\frac{du}{dt} = \frac{\partial u}{\partial x} \cdot \frac{dx}{dt} + \frac{\partial u}{\partial y} \cdot \frac{dy}{dt} + \frac{\partial u}{\partial z} \cdot \frac{dz}{dt},$$

and if, further,  $y = \varphi(x)$  and  $z = \psi(x)$ ,

$$[586] \quad \frac{du}{dx} = \frac{\partial u}{\partial x} + \frac{\partial u}{\partial y} \cdot \frac{dy}{dx} + \frac{\partial u}{\partial z} \cdot \frac{dz}{dx}.$$

These latter formulae are very useful in differentiating complicated functions of a single variable.

EXAMPLE.—Find  $\frac{du}{dx}$ , when  $u = xe^{\sqrt{a^2 - x^2}} (\sin^3 x)$ .

Let

$$y = \sqrt{a^2 - x^2}.$$

$$z = \sin^3 x.$$

Then

$$u = xe^{yz}.$$

$$\frac{\partial u}{\partial x} = e^{yz}, \quad \frac{\partial u}{\partial y} = xe^{yz}, \quad \frac{\partial u}{\partial z} = xe^y.$$

Also,

$$\frac{dy}{dx} = -\frac{x}{\sqrt{a^2 - x^2}}, \quad \frac{dz}{dx} = 3 \sin^2 x \cdot \cos x.$$

Substituting these derivatives in

$$\frac{du}{dx} = \frac{\partial u}{\partial x} + \frac{\partial u}{\partial y} \cdot \frac{dy}{dx} + \frac{\partial u}{\partial z} \cdot \frac{dz}{dx}, \quad [586]$$

we have

$$\begin{aligned} \frac{du}{dx} &= e^{yz} - \frac{x^2 e^{yz}}{\sqrt{a^2 - x^2}} + 3xe^y \sin^2 x \cdot \cos x \\ &= e^{\sqrt{a^2 - x^2}} \left[ \sin^3 x \left( 1 - \frac{x^2}{\sqrt{a^2 - x^2}} + 3x \cot x \right) \right]. \end{aligned}$$

**989. Total Differentials.**—We have already (Art. 985) developed the formula for a total differentiation. If we multiply through by  $dt$  in

$$\frac{du}{dt} = \frac{\partial u}{\partial x} \cdot \frac{dx}{dt} + \frac{\partial u}{\partial y} \cdot \frac{dy}{dt} + \frac{\partial u}{\partial z} \cdot \frac{dz}{dt},$$

we get

$$[587] \quad du = \frac{\partial u}{\partial x} dx + \frac{\partial u}{\partial y} dy + \frac{\partial u}{\partial z} dz.$$

This formula may be extended to apply to any number of variables.

**990. Differentiation of Implicit Functions.**—Suppose that  $y$  is defined implicitly as a function of  $x$  by the equation,

$$f(x, y) = 0.$$

Since the function  $f(x, y)$  has by definition the constant value zero for all corresponding values of  $x$  and  $y$ , the total differential must also be zero, or

$$\frac{\partial f}{\partial x} dx + \frac{\partial f}{\partial y} dy = 0.$$

Transposing the first term to the second member of the equation and dividing both members by

$$\frac{\partial f}{\partial y} \text{ and } dx$$

gives

$$[588] \quad \frac{dy}{dx} = - \frac{\frac{\partial f}{\partial x}}{\frac{\partial f}{\partial y}}.$$

This is a very convenient method of writing at once the derivative  $\frac{dy}{dx}$  of an implicit function and should be used instead of the method given earlier in Art. 908.

EXAMPLE.—Find  $\frac{dy}{dx}$ , given

$$f(x, y) = x^2y - xy^3 = 0.$$

$$\frac{\partial f}{\partial x} = 2xy - y^3, \quad \frac{\partial f}{\partial y} = x^2 - 3xy^2.$$

Therefore,

$$\frac{dy}{dx} = - \frac{\frac{\partial f}{\partial x}}{\frac{\partial f}{\partial y}} = - \frac{2xy - y^3}{x^2 - 3xy^2}.$$

CHAPTER LI  
INTEGRAL CALCULUS

ELEMENTARY FORMS

**991.** In differential calculus, we studied the methods of finding the rate of change of a quantity at any given instant. In the integral calculus, we are given the rate at which a quantity is changing and we desire to find the value of the quantity at any instant. This given rate of change of the quantity whose value is desired is the derivative of the quantity. The one case is the reverse of the other in the same manner as division is the reverse of multiplication and involution is the reverse of evolution.

Consider the law of falling bodies. The value of the velocity (rate of change of distance with respect to time) at any instant is given by the equation,

$$v = gt,$$

or we can put this into the form,

$$\frac{ds}{dt} = gt.$$

We are given the rate of change of space and we desire to find a formula which gives the space traversed in the time  $t$ . We know that this formula is

$$s = \frac{gt^2}{2},$$

and our problem consists in finding a method of determining it from the equation for the rate of change of space or velocity. This process of finding a function whose derivative or rate of change is given is called *integration*.

**992.** Let  $f(x)$  denote the given derivative which may be  $x^n$ ,  $\log x$ , or any other function of  $x$ , and let  $F(x)$  be the required function whose derivative is  $f(x)$ . Then

$$\frac{d[F(x)]}{dx} = f(x). \tag{1}$$

The sign  $\int$  before a quantity indicates that the operation of integration is to be performed on the expression which follows, in the same manner as  $\sqrt{\quad}$  indicates that the square root of the enclosed quantity is to be extracted, and  $dx$  following the expression means that the expression is the derivative of the required function with respect to  $x$ .

The reverse operation of (1) would then be indicated by

$$\int f(x)dx = F(x). \tag{2}$$

In other words,  $F(x)$  is a function whose first derivative with respect to  $x$  is  $f(x)$ .

Some writers show these symbols in a different form, as

$$\int \frac{dx}{x}, \quad \int \frac{dx}{1+x^2} \text{ etc.}$$

but do not get confused, for these forms mean the integration of

$$\frac{1}{x} \text{ and } \frac{1}{1+x^2},$$

or the integration of the remaining part of the expression after  $\int$  and  $dx$  are withdrawn as symbols of operation.

In algebra, we learned that

$$\sqrt[n]{a^n} = a,$$

or by performing inverse operations on a quantity, we obtained the original quantity. In the same manner,

$$\frac{d}{dx} \int f(x)dx = f(x),$$

or

$$\int \left[ \frac{d}{dx} F(x) \right] dx = F(x),$$

which shows that

$$\frac{d}{dx} \text{ and } \int \dots dx$$

have contrary effects.

In the same manner if  $u$  is some function of  $x$ , then

[589] 
$$\int \frac{du}{dx} \cdot dx = u,$$

which is a very useful form.

**993. Constants of Integration.**—From the differential calculus, the addition of a constant to the expression does not affect the

rate of change of the function represented by the expression. For the same value of  $x$ , the slope of the curves was the same. For this reason, if we are given the slope or derivative or rate of change of a function, we must have additional information which will help us to determine the constant term and thus to enable

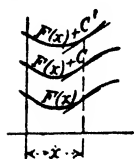

FIG. 576.

us to fix the location of the curve which the integrated expression represents.

If we have a starting point or a condition given, we can determine this constant.

It is, therefore, quite essential when integrating, to add a constant, thus,

$$\int f(x)dx = F(x) + C.$$

If we find the derivatives of

$$y = x^3 + 6,$$

$$y = x^3 + 1,$$

$$y = x^3 + 10,$$

we see that all of these curves have

$$\frac{dy}{dx} = 3x^2.$$

Now if we are given  $3x^2$  to integrate, the required function may be any one of the three above, as well as

$$y = x^3 + \text{any constant.}$$

The curves are all similar, and for a given  $x$ , they all have the same slope, but they are shifted vertically from each other, and to fix upon any one as the function, the constant of integration must be determined.

**994. Integration of  $x^n$ .**—The process of integration is much more difficult than that of differentiation and many cases cannot be readily integrated. In fact, many forms have been tabulated from the differential calculus but put into the reverse form of integration.

If we differentiate

$$y = \frac{1}{n+1} x^{n+1} + C,$$

we get

$$\frac{dy}{dx} = \frac{n+1}{n+1} x^n = x^n.$$



Now by reversing the operation,

$$[590] \quad \int x^n dx = \frac{1}{n+1} x^{n+1} + C.$$

Another example is

$$y = -\cos x + C.$$

$$\frac{dy}{dx} = \sin x.$$

Reversing the operation gives

$$\int \sin x dx = -\cos x + C.$$

From the first example, we see that the differentiation of a power of  $x$  gives a function of one degree lower, while the integration gives a function of degree one higher than the original function.

If  $f(x) = x^n$ , or  $\frac{dy}{dx} = x^n$ ,

then

$$F(x) = y = \frac{x^{n+1}}{n+1} + C.$$

We can now, making use of this form, integrate various powers at sight, thus,

$$\frac{dy}{dx} = x^{10}, \quad y = \frac{x^{11}}{11} + C.$$

$$\frac{dy}{dx} = x^{-4}, \quad y = \frac{x^{-3}}{-3} + C.$$

$$\frac{dy}{dx} = x^{\frac{1}{4}}, \quad y = \frac{x^{\frac{5}{4}}}{\frac{5}{4}} + C.$$

**995. A Constant Factor.**—Let  $y = au$  where  $u$  is some function of  $x$ . Differentiating,

$$\frac{d(au)}{dx} = a \frac{du}{dx},$$

in which  $a$  is a constant factor.

Reversing the operation, or integrating,

$$\int a \frac{du}{dx} dx = au.$$

But

$$\int \frac{du}{dx} dx = u.$$

Then

$$[591] \quad \int a \frac{du}{dx} dx = a \int \frac{du}{dx} dx,$$

which shows that any constant factor of a function given for integration can be written either before or after the sign of integration.

**996. Integration of Sums and Differences.**—From the differential calculus,

$$\frac{d(u + v - w)}{dx} = \frac{du}{dx} + \frac{dv}{dx} - \frac{dw}{dx}.$$

By integration of the above we obtain,

$$\int \left( \frac{du}{dx} + \frac{dv}{dx} - \frac{dw}{dx} \right) dx = u + v - w + C.$$

But

$$u = \int \frac{du}{dx} \cdot dx, v = \int \frac{dv}{dx} \cdot dx, w = \int \frac{dw}{dx} \cdot dx.$$

Hence,

$$[592] \quad \int \left( \frac{d(u + v - w)}{dx} \right) dx = \int \left( \frac{du}{dx} + \frac{dv}{dx} - \frac{dw}{dx} \right) dx = \int \frac{du}{dx} \cdot dx + \int \frac{dv}{dx} \cdot dx - \int \frac{dw}{dx} \cdot dx.$$

The integral of the sum of two or more terms is equal to the sum of the integrals of the separate terms. Thus,

$$\int \left( \frac{du}{dx} + \frac{dv}{dx} \right) dx = \int \frac{du}{dx} \cdot dx + \int \frac{dv}{dx} \cdot dx = u + v + C.$$

Likewise,

$$\int \left( \frac{du}{dx} - \frac{dv}{dx} \right) dx = \int \frac{du}{dx} \cdot dx - \int \frac{dv}{dx} \cdot dx = u - v + C.$$

The integral of a difference of two terms is equal to the difference of their integrals.

**997. Areas by Integration.**—One of the principal applications of integration is to the problem of finding the area under a given curve.

The only condition is that the graph must be continuous for the interval considered.

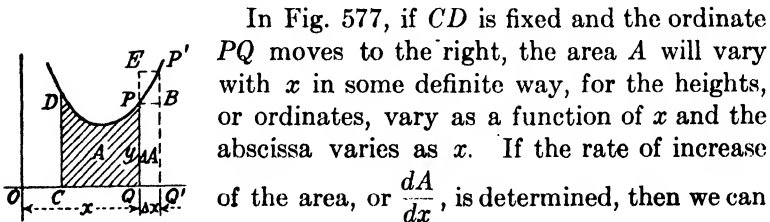

FIG. 577.

find  $A$  by integration.

If we increase  $x$  by  $\Delta x$ , then  $A$  is increased by  $\Delta A$ . From the figure, the area of the rectangle  $PBQQ'$  is  $y \cdot \Delta x$  and the area of the rectangle  $EP'Q'Q$  is  $(y + \Delta y)\Delta x$ .

Then from the figure, if the curve rises from  $P$  to  $P'$ ,

$$\text{Rectangle } PBQQ' < \Delta A < \text{Rectangle } EP'Q'Q,$$

or

$$y \cdot \Delta x < \Delta A < (y + \Delta y)\Delta x.$$

If the curve is falling from  $P$  to  $P'$ , then

$$(y + \Delta y)\Delta x < \Delta A < y \cdot \Delta x.$$

Now dividing by  $\Delta x$ , we have

$$y < \frac{\Delta A}{\Delta x} < y + \Delta y, \text{ if curve is rising.}$$

$$y + \Delta y < \frac{\Delta A}{\Delta x} < y, \text{ if curve is falling.}$$

As  $\Delta x$  approaches zero,  $y + \Delta y$  approaches  $y$  as a limit.

Then, whether the curve is rising or falling from  $P$  to  $P'$ ,  $\frac{\Delta A}{\Delta x}$  has a value between  $y$  and an expression which has  $y$  as a limiting value, as  $\Delta x$  approaches zero.

Therefore,

$$\frac{\Delta A}{\Delta x} \text{ approaches } y \text{ as a limit as } \Delta x \text{ approaches zero.}$$

This expression is the average rate of increase of  $A$  for the interval  $\Delta x$ . Writing the above in symbols,

$$\lim_{\Delta x \rightarrow 0} \left[ \frac{\Delta A}{\Delta x} \right] = \frac{dA}{dx} = y = f(x).$$

Since  $y$  and  $f(x)$  are the same thing, that is, the ordinate, one may be substituted for the other. From this last form, it will be seen that the rate at which the area  $A$  is increasing at any point is equal to the height of the curve or the ordinate at that point.

Since

$$\frac{dA}{dx} = y = f(x),$$

$$\therefore dA = y \cdot dx = f(x)dx.$$

[593]

$$\therefore A = \int y \cdot dx = \int f(x)dx.$$

We can now find the area under any curve when an equation giving the height  $y$  in terms of the horizontal distance  $x$  is known

( $x$  measured from any fixed point), providing that we can integrate  $y \cdot dx$ .

EXAMPLE.—Find the area under the curve,  $y = x^2$ , between the fixed ordinate erected at  $x = 1$  and any moving ordinate beyond.

Then

$$A = \int y \cdot dx \text{ becomes } \int x^2 dx.$$

$$A = \int x^2 dx = \frac{x^3}{3} + C.$$

If the area increases from  $x = 1$  as a starting point, then  $A = 0$  when  $x = 1$ , or

$$\frac{(1)^3}{3} + C = 0.$$

$$\therefore C = -\frac{1}{3},$$

which substituted above gives the formula for the increasing area as

$$\frac{x^3}{3} - \frac{1}{3}.$$

If we desire to find the area when  $x = 5$ , then

$$\frac{(5)^3}{3} - \frac{1}{3} = \frac{125}{3} - \frac{1}{3} = 41.333+.$$

To find the area between the curve, the  $X$ -axis and the given ordinates when the curve is below the  $X$ -axis, the same reasoning can be followed, but the area will be the negative of the integral, or

$$A = -\int y dx = -\int f(x) dx.$$

In case the curve is both above and below the  $X$ -axis, the resulting area will be the areas above the  $X$ -axis minus the areas below the  $X$ -axis.

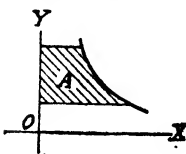

FIG. 578.

In the same manner, the area between the curve, the  $Y$ -axis, and two abscissae becomes

$$A = \int x dy.$$

This may be seen by reference to Fig. 578.

In Fig. 579 is shown the graph of the function,  $y = x^2$ , and the area between the curve, the  $Y$ -axis, and the abscissae  $y = 0$  and  $y = a$  is given by

$$A = \int y^{\frac{1}{2}} dy + C.$$

When  $y = 0$ ,  $A = 0$  and, therefore,  $C = 0$  and

$$A = \int y^{\frac{1}{2}} dy = y^{\frac{3}{2}} \times \frac{2}{3} = \frac{2a^{\frac{3}{2}}}{3}.$$

In Fig. 580 is shown the graph of the function,  $y^2 = x$ , and the area between the curve, the X-axis, and the ordinates  $x = 0$  and  $x = a$  is given by

$$A = \int x^{\frac{1}{2}} dx + C.$$

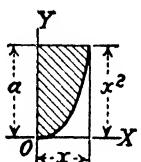

FIG. 579.

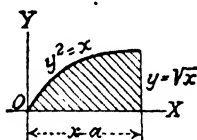

FIG. 580.

When  $x = 0$ ,  $A = 0$  and, therefore,  $C = 0$  and

$$A = \int x^{\frac{1}{2}} dx = x^{\frac{3}{2}} \times \frac{2}{3} = \frac{2a^{\frac{3}{2}}}{3}.$$

Area of rectangle =  $a \times \sqrt{a} = a^{\frac{3}{2}}$ .

Therefore, the area under the parabola equals two-thirds the area of the rectangle.

**998. Mean Value Problems.**—In many problems where the quantity varies, it is necessary to find the average value of the quantity over a given time. This average value is called a mean value and is represented graphically by an ordinate which is the average of all ordinates for a certain distance. It is that height which, multiplied by the base, would give the area under the curve.

If we consider an example with the ordinates showing how the speed varied during an interval of time, and we desire the distance traveled, we simply have the *average* speed multiplied by the number of units in the interval of time, or in other words, the area under the curve between the ordinates which fix the interval of time.



FIG. 581.

**999. Area Equivalents.**—Many engineering problems may be solved by considering that the area under a curve represents the function.

In (a) the slope is constant, or uniform. The distance is equal to the product of the time by the average velocity, or in

other words, the area under the curve is a measure of the distance traveled during the time considered.

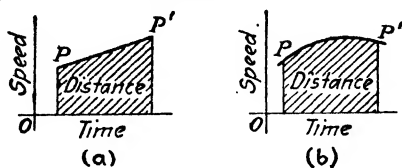

FIG. 582.

In (b) the case is the same except that the velocity does not increase uniformly, or the acceleration is variable. In both cases, the value of  $y$  is the velocity or the rate of change of space with respect to the time.

Another example is the finding of impulse from a force-time graph (Fig. 583). Other examples are shown in Figs. 584, 585, and 586.

$$\text{Impulse} = \text{Average force} \times \text{Time.}$$

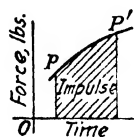

FIG. 583.

$$\text{Velocity} = \text{Average acceleration} \times \text{Time.}$$

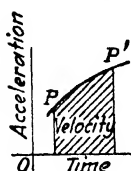

FIG. 584.

$$\text{Work} = \text{Average force} \times \text{Distance.}$$

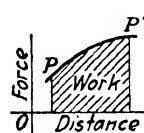

FIG. 585.

$$\text{Volume} = \text{Average cross-section} \times \text{Height.}$$

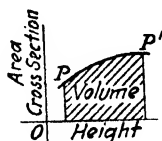

FIG. 586.

**EXAMPLE.**—Find the impulse  $Q$  imparted to a moving object by a variable force  $F$  at the end of  $t$  seconds after starting.

In an additional interval of time  $\Delta t$ , further impulse  $\Delta Q$  is imparted in a similar manner as in the area under a curve (Art. 997).

In the same manner consider the rectangles  $PBQQ'$  and  $EP'Q'Q$ .

$$F\Delta t < \Delta Q < (F + \Delta F)\Delta t.$$

Dividing by  $\Delta t$ ,

$$F < \frac{\Delta Q}{\Delta t} < F + \Delta F.$$

As  $\Delta t$  approaches zero,  $F + \Delta F$  approaches  $F$  and  $\frac{\Delta Q}{\Delta t}$  approaches  $F$ .

Then, as before,

$$\lim_{\Delta t \rightarrow 0} \left[ \frac{\Delta Q}{\Delta t} \right] = \frac{dQ}{dt} = F, \text{ or } dQ = Fdt.$$

$$\therefore Q = \int Fdt.$$

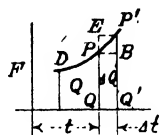

FIG. 587.

**Distance.**—In a similar manner, for a speed-time graph, the formula is

$$s = \int vdt.$$

**Velocity.**—In a similar manner, for an acceleration-time graph, the area under the curve gives the total change in velocity, or

$$\text{Change in velocity} = v = \int a dt.$$

**Work.**—The formula for work or the area under a force-distance graph is

$$\text{Work} = \int Fds.$$

**Volume.**—The volume formula or the area under a graph of a cross-sectional slice  $A_s$ , given in terms of the height considered which we will call  $x$ , is

$$\text{Volume} = V = \int A_s dx.$$

**1000. Area in Polar Coordinates.**—Let  $\rho = f(\theta)$  be the polar equation with  $f(\theta)$  single valued and continuous. We wish to determine the area between the radii vectors  $OB$  and  $OC$  (whose angles are  $\alpha$  and  $\beta$  measured from the initial line) and the curve  $\rho = f(\theta)$ .

Let  $OP$  represent a radius vector that makes an angle  $\theta$  with the initial line. Let  $\theta$  take an increment  $\Delta\theta$ . Let  $OS$  represent the radius vector that makes an angle  $\theta + \Delta\theta$  with the initial line.  $\rho$  becomes  $\rho + \Delta\rho$ .

As  $\theta$  takes the increment  $\Delta\theta$ , the area  $BOP$ , or  $A$ , takes an increment  $\Delta A$ . If the rate of increment, as  $\frac{dA}{d\theta}$ , is determined as

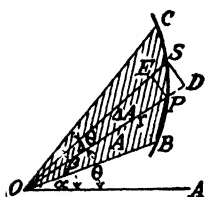

FIG. 588.

in the case of rectangular coordinates, then  $A$  can be found by integration.

From the figure, the area of the sector  $POE$  of the circle is one-half the product of the radius by the arc  $PE$ , or

$$\frac{1}{2}\rho \times \rho\Delta\theta,$$

and the area of the sector of the circle  $DOS$  is

$$\frac{1}{2}[\rho + \Delta\rho][\rho + \Delta\rho]\Delta\theta.$$

Then, by comparing sectors,

$$\frac{1}{2}\rho^2\Delta\theta < \Delta A < \frac{1}{2}[\rho + \Delta\rho]^2\Delta\theta,$$

if  $\rho$  or  $f(\theta)$  is increasing from  $P$  to  $S$ , or

$$\frac{1}{2}[\rho + \Delta\rho]^2\Delta\theta < \Delta A < \frac{1}{2}\rho^2\Delta\theta,$$

if  $\rho$  or  $f(\theta)$  is decreasing from  $P$  to  $S$ .

Now divide through by  $\Delta\theta$ . Then

$$\frac{\rho^2}{2} < \frac{\Delta A}{\Delta\theta} < \frac{[\rho + \Delta\rho]^2}{2}$$

if  $\rho$  is increasing, and

$$\frac{[\rho + \Delta\rho]^2}{2} < \frac{\Delta A}{\Delta\theta} < \frac{\rho^2}{2}$$

if  $\rho$  is decreasing.

As  $\Delta\theta$  approaches zero,

$$\frac{[\rho + \Delta\rho]^2}{2} \text{ approaches } \frac{\rho^2}{2}$$

whether  $\rho$  is increasing or decreasing, and  $\frac{\Delta A}{\Delta\theta}$  has a value that lies between  $\frac{\rho^2}{2}$  and a quantity that approaches  $\frac{\rho^2}{2}$  as a limit.

Therefore,

$$\frac{\Delta A}{\Delta\theta} \text{ approaches } \frac{\rho^2}{2}$$

as  $\Delta\theta$  approaches zero.

$$\lim_{\Delta\theta \rightarrow 0} \left[ \frac{\Delta A}{\Delta\theta} \right] = \frac{dA}{d\theta} = \frac{\rho^2}{2} = \frac{1}{2} [f(\theta)]^2.$$

Therefore,

$$[594] \quad A = \frac{1}{2} \int \rho^2 d\theta, \text{ or } \frac{1}{2} \int f(\theta)^2 d\theta + C.$$



EXAMPLE.—Find the area enclosed by the curve,

$$\begin{aligned} \rho &= a\sqrt{1 - \cos \theta}. \\ A &= \int \frac{\rho^2}{2} d\theta = \int \frac{(a\sqrt{1 - \cos \theta})^2}{2} d\theta. \\ &= \frac{a^2}{2} \int (1 - \cos \theta) d\theta. \\ &= \frac{a^2}{2} [\theta - \sin \theta] + C. \end{aligned}$$

When  $\theta = 0$ ,  $A = 0$ .  $\therefore C = 0$ .

When  $\theta = 2\pi$ ,  $A = \frac{a^2}{2}(2\pi - 0) = \pi a^2$ .

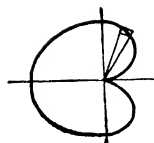

FIG. 589.

CHAPTER LII  
 GRAPHICAL INTEGRATION

GRAPHICAL METHODS OF INTEGRATION

1001. **Graphical Integration.**—In Art. 916, it was shown that the ordinates of the integral curve measure the area of strips under the curve which is integrated. The following graphical method is based on this principle and the ordinates are so arranged that the ordinate representing each strip is added to

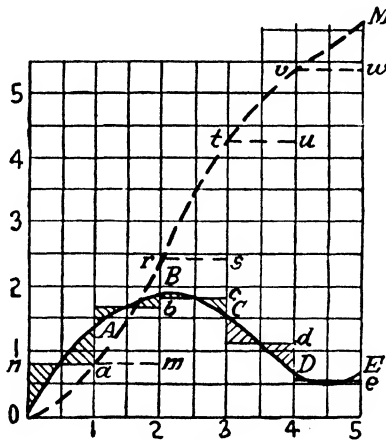

FIG. 590.

the sum of the ordinates representing the preceding strips in the same manner as in the summation method (Art. 1036).

Consider the given graph  $OABCDE$  which we wish to integrate graphically (Fig. 590).

Two facts should be continually remembered:

1. When  $y = f(x)$  has a maximum or minimum point,  $y = F(x)$  crosses the X-axis.
2. When  $y = f(x)$  has a maximum or minimum point,  $y = F(x)$  must have an inflexion point.

Thus in Fig. 590, the  $OM$  curve must be tangent to the curve at the origin and must have an inflexion point at  $x = 4\frac{1}{2}$ ; and in Fig. 591, the integral curve must have a maximum point just to the left of  $x = 3$ .

Starting with the first strip  $OA1$ , determine the mean height of the strip by drawing a horizontal line  $an$ , located so as to equalize the areas of the two shaded triangles. After a little practice, the eye will judge very accurately the position of the line  $an$ . Plot  $1a$  as the ordinate measuring the strip. Find the average ordinate  $b_2$  for the second strip in the same manner but produce  $an$  to  $m$  and make  $mr$  equal to  $b_2$ . Then  $r_2$  measures the sum of the two ordinates, or the area under the curve  $OAB$ .

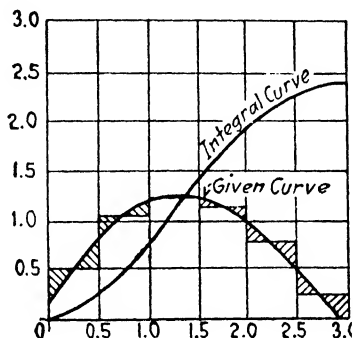

FIG. 591.

Continue in this manner for the various strips, and  $M_5$  measures the area  $OABCDE$  in square units.

In case the strip has a width which is a fraction of a unit, the proportional divider, a much neglected instrument, is very useful. In Fig. 591, the width of the strips is taken as .5 unit and the proportional divider is set to a ratio of 2:1, and then the integral is measured direct on the vertical ordinate scale.

If the width of the strips is taken as 2 units, then the proportional divider is set to a ratio of 1:2.

If the width of the strips is taken as 10 or 20 units, it is advisable to consider a new scale for the ordinates of the integral curve that is ten or twenty times the ordinates of the curve which is being integrated.

**1002. Graphical Determination of Constant of Integration.—**

Consider the function,

$$y = 6x^2 + 6x - 36,$$

and construct the graph as shown in Fig. 592.

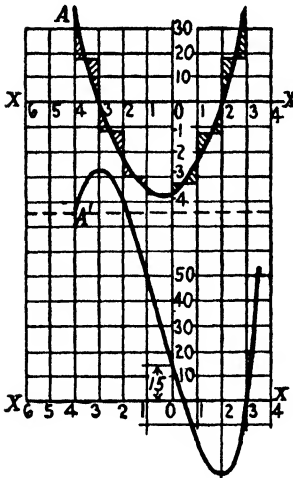

FIG. 592.

Begin at *A* and construct the integral curve. Now there is nothing to show the location of the *X*-axis, for the integral curve will represent the integration of the given curve wherever we locate the *X*-axis.

If, however, we have the additional information that the value of the integral is 15 when  $x = 0$ , we can immediately locate the origin at a point 15 units below the intersection of the integral curve and the *Y*-axis, or where  $x = 0$ .

**1003. Work Required to Stretch a Spring.—**Let *W* be the work required to stretch a spring through a distance *s*. Therefore, *W* is a function of *s*; that is, the algebraic function must express *W* in terms of *s*.



FIG. 593.

According to Hooke's law, the elongation is proportional to the force, or

$$F = ks,$$

where *k* is a constant depending upon the spring.

But

$$\text{Work} = \int F ds.$$

Substituting  $F = ks$ , then

$$\text{Work} = \int ks ds = \frac{1}{2}ks^2 + C.$$

When  $W = 0, s = 0$ . Then  $C = 0$ .

$$\therefore W = \frac{ks^2}{2}.$$

**1004. Example of Graphical Integration.—**We desire to find the work done in the expansion of 1 pound of dry, saturated steam from a pressure of 100 pounds per square inch to 15 pounds per square inch.

The primary curve is first plotted from data given in a steam table, and the integral curve was plotted from this curve using a proportional divider set to a 10:1 ratio (Fig. 594).

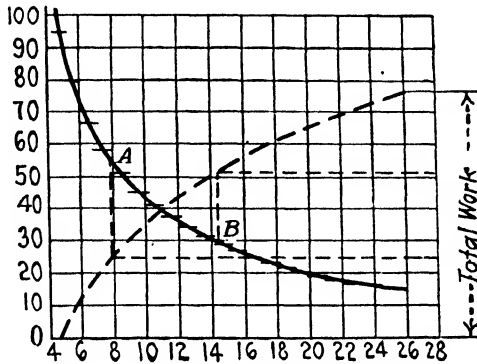

FIG. 594.

The work done is

$$77 \times 10 \times 144 = 110,880 \text{ foot-pounds.}$$

NOTE. 144 is a factor because the data gives the pressure in pounds per square inch, which must be reduced to pounds per square foot.

Suppose the work of expansion of this example is to be divided equally between the three cylinders of a triple-expansion engine. Then divide the ordinate representing the work done into three equal divisions and project the points of division horizontally onto the integral curve and then vertically onto the expansion curve. The points thus located determine the initial pressures for each cylinder, as *A* and *B*.

**1005. Graphical Integration of Velocity Graphs.**—The speedometer of an automobile traveling over an uneven country road gave the following readings for the different periods of time taken from the time of starting. Find the distance traveled during any time interval. Time is given in minutes and velocity in miles per hour.

Time.....	0	1	2	3	4	5	6	7	8
Velocity.....	0	10	20	25	28	29	26	24	20

From the nature of the problem,

$$\text{Distance} = \int v dt.$$

By plotting the speed-time curve and integrating, we find the distance traveled.

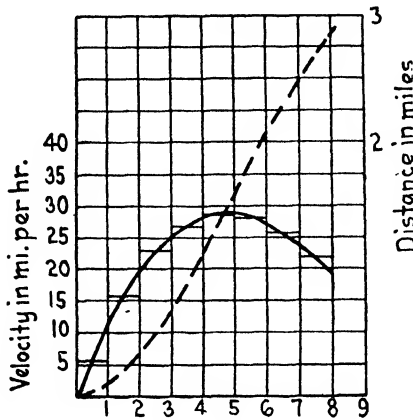

FIG. 595.

The curve is plotted and the proportional divider set in the ratio of 3:1 and the integral curve made. Now since velocity is in miles per hour, the ordinates must be divided by 60, but since the proportional divider is set to a 3:1 ratio, the vertical scale must be divided by 20.

After 3 minutes the automobile has traveled three-quarters of a mile, and 8 minutes after starting the distance was a little less than 3 miles.

**1006. Standard Forms of Integral Curves.**—The principle of transposing the origin of standard curves to make them represent a given equation can also be applied to curves of integration in the same manner as in differentiation, although the values of  $h$  and  $k$  are different in the two cases.

**1007. Graph of the Integral of  $a$ .**

$$\int a dx = ax + b.$$

If  $a = 1$ , the graph is shown in Fig. 596.

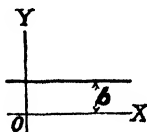

FIG. 596.

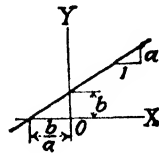

FIG. 597.

If  $a =$  any other finite value than 1, the graph is shown in Fig. 597, where

$$a = \text{slope, } Y\text{-intercept} = b, \text{ and } X\text{-intercept} = -\frac{b}{a}$$

**1008. Graph of the Integral of a Constant with Various Integration Constants.**—In Fig. 598 is shown the graph of the integration of  $y = 2$  when the constant of integration equals 12.

The dotted lines show the integral curves for  $y = 2$  for different constants.

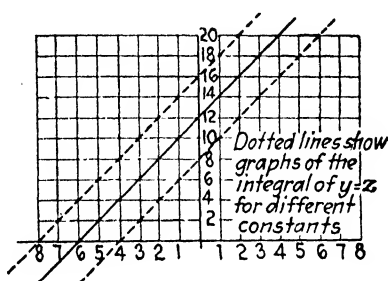

FIG. 598.

**1009. Graph of the Integral of  $y = ax + b$ .**—From analytical method,

$$\int(ax + b)dx = \frac{ax^2}{2} + bx + C.$$

This integral curve is a parabola. We will, therefore, take a curve of  $y = x^2$ , change the vertical scale as shown in Fig. 599, and by substituting  $\frac{a}{2}$  for  $a$  in the transformation forms (Art. 172), locate an origin which will make the curve represent the integral curve. Then

$$h = \frac{b}{2 \cdot \frac{a}{2}} = \frac{b}{a}$$

$$k = \frac{b^2 - 4 \cdot \frac{a}{2} c}{4 \cdot \frac{a}{2}} = \frac{b^2 - 2ac}{2a} = \frac{b^2}{2a} - C.$$

EXAMPLE.—In Fig. 599 is shown the graphical integration of

$$y = 6x + 6,$$

with a constant of integration equal to  $-12$ .

$$h = \frac{1}{3} = 1, C = -12, k = \frac{1}{3} + 12 = 15.$$

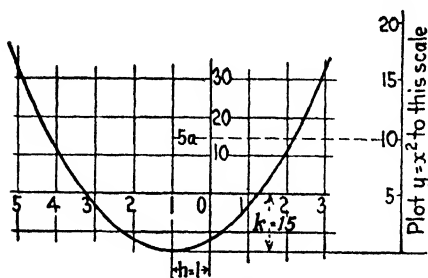

FIG. 599.

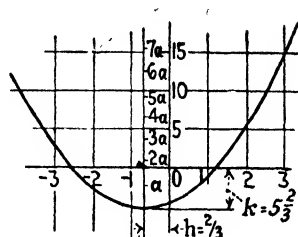

FIG. 600.

Figure 600 shows the graph of

$$y = 3(3x + 2),$$

when the constant of integration is assumed to be  $-5$ .

$$h = \frac{b}{a} = \frac{2}{3}$$

$$k = \frac{b^2}{2a} - C = \frac{4}{6} + 5 = 5\frac{2}{3}.$$

**1010. Graph of the Integral of  $y = ax^2 + bx + c$ .**—Following the same principle as in the previous case, we get the values for  $h$  and  $k$ . In this case, however, the  $a$  is one-third as large and the  $b$  is one-half as large as in the standard transformation formulae. Then

$$h = \frac{\frac{b}{2}}{3 \cdot \frac{a}{3}} = \frac{b}{2a}, \quad k = \frac{\frac{b}{2} \cdot c}{3 \cdot \frac{a}{3}} - \frac{2 \frac{b^3}{8}}{27 \frac{a^2}{9}} = \frac{bc}{2a} - \frac{b^3}{12a^2} \\ = -\frac{b}{2a} \left( \frac{b^2 - 6ac}{6a} \right) - \text{constant}.$$

$$m = c - \frac{\frac{b^2}{4}}{3 \cdot \frac{a}{3}} = c - \frac{b^2}{4a}.$$



EXAMPLE.—Integrate graphically.

$$y = \frac{3x^2}{2} + 2x - 5.$$

$$a = \frac{3}{2}, b = 2, c = -5.$$

$$h = \frac{2}{2 \cdot \frac{3}{2}} = \frac{2}{3}, k = \frac{2(-5)}{2 \cdot \frac{3}{2}} - \frac{8}{12 \cdot \frac{9}{4}} = -3.63.$$

$$m = -5 - \frac{4}{4 \cdot \frac{3}{2}} = -5 \frac{2}{3}.$$

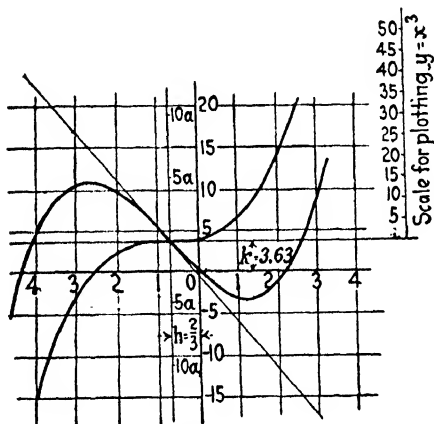

FIG. 601.

## CHAPTER LIII

### THE DEFINITE INTEGRAL

#### INTEGRATION BETWEEN LIMITS

**1011. Definite Integrals.**—A shorter method for finding areas, volumes, etc., under a part of the curve from  $P$  to  $P'$  is as follows:

Consider the area under the curve,

$$y = 2\sqrt{x},$$

between the ordinates representing  $x = 2$  and  $x = 4$ .

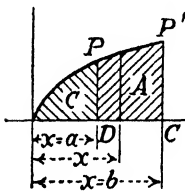

FIG. 602.

From the area formula,

$$\begin{aligned} A &= \int 2\sqrt{x} dx = 2 \int x^{\frac{1}{2}} dx = \frac{2x^{\frac{3}{2}}}{\frac{3}{2}} + C \\ &= \frac{4x^{\frac{3}{2}}}{3} + C. \end{aligned}$$

We begin to measure the area when  $x = 2$ , and then  $A = 0$ , or

$$0 = \frac{4(2)^{\frac{3}{2}}}{3} + C.$$

$$\therefore C = -\frac{4}{3}(2)^{\frac{3}{2}}.$$

The area formula then is

$$A = \frac{4}{3}x^{\frac{3}{2}} - \frac{4}{3}(2)^{\frac{3}{2}}.$$

This last formula gives the area under the curve for any point  $x$  beyond 2. If  $x = 4$ , then

$$A = \frac{4}{3}(4)^{\frac{3}{2}} - \frac{4}{3}(2)^{\frac{3}{2}}.$$

Similarly, if we wished to find the area from  $x = a$  to  $x = b$ , we would find

$$A = \frac{4}{3}(b)^{\frac{3}{2}} - \frac{4}{3}(a)^{\frac{3}{2}}.$$

The final result is simply the difference between the values of the integral function at the beginning and at the end of the interval considered.

The symbol,

$$\int_a^b f(x) dx$$

is used to denote the difference between the values of the integral function at  $x = b$  and  $x = a$  and is called the *definite integral from a to b*, while  $a$  and  $b$  are called the *limits of integration*.

This difference is also written,

$$\int_a^b f(x)dx = \int_2^4 2\sqrt{x}dx = \left[ \frac{4}{3}(x)^{\frac{3}{2}} \right]_2^4.$$

Since the integrals representing areas, volumes, work, etc. are all of the same form, the definite integral formula can be applied to all.

$$V = \int_a^b A dx.$$

[595]

$$W = \int_a^b F dx.$$

**1012. Mean value of  $f(x)$**  is represented by the mean ordinate or the average ordinate, or

$$\text{Mean value of } f(x) = \frac{\int_a^b f(x)dx}{b-a}.$$

(from  $x = a$  to  $x = b$ )

Since

$$\int_a^b f(x)dx = \text{area } APQE,$$

if we construct on the base  $AE$ , which equals  $(b - a)$ , the rectangle  $ACBE$  whose area equals the area  $APQE$  then

$$\begin{aligned} \text{Mean value} &= \frac{\text{area } ACBE}{b-a} \\ &= \frac{AE \cdot FD}{AE} = FD. \end{aligned}$$

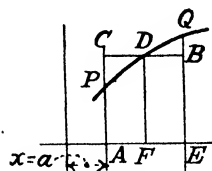

FIG. 603.

**1013. Determination of Mean Ordinate Graphically.**—Suppose that  $A'B'$  is the given curve and that we desire to find a mean ordinate graphically between  $x = a$  and  $x = b$ .

Integrate graphically as usual and obtain  $C$  units as the measure of the area. Lay off this distance horizontally beginning at  $a$ . The mean ordinate is  $\frac{C}{b-a}$ . Then by erecting an ordi-

nate at  $A$  equal to unity and drawing a line  $aBD$  cutting the perpendicular line  $ED$ , the line  $DE$  will measure the mean ordinate.

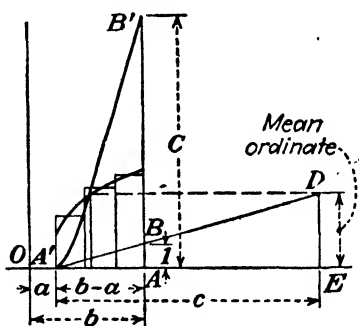

FIG. 604.

PROOF.—From similar triangles,

$$\text{Mean ordinate} : C :: 1 : b - a, \text{ or Mean ordinate} = \frac{C}{b - a}.$$

1014. Interchange of Limits.—Since

$$\int_a^b f(x) dx = F(b) - F(a), \text{ where } F(x) = \int f(x) dx,$$

and

$$\int_b^a f(x) dx = F(a) - F(b),$$

then,

$$[596] \quad \int_a^b f(x) dx = - \int_b^a f(x) dx.$$

Interchanging the limits is equivalent to changing the sign of the definite integral.

1015. Decomposing the Limits of Integration.—If

$$\int_a^{x_1} f(x) dx = F(x_1) - F(a)$$

and

$$\int_{x_1}^b f(x) dx = F(b) - F(x_1),$$

adding,

$$\int_a^{x_1} f(x) dx + \int_{x_1}^b f(x) dx = F(b) - F(a).$$

But

$$\int_a^b f(x) dx = F(b) - F(a).$$

Therefore,

$$\int_a^b f(x) dx = \int_a^{x_1} f(x) dx + \int_{x_1}^b f(x) dx,$$

or (Fig. 605),

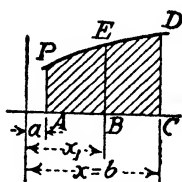

FIG. 605.

$$\int_a^b f(x)dx = \text{area } APDC.$$

$$\int_a^{x_1} f(x)dx = \text{area } APEB.$$

$$\int_{x_1}^b f(x)dx = \text{area } BEDC.$$

**1016. Area in Parametric Form.**—Let the equations be

$$x = f(t), \quad y = \varphi(t).$$

Then

$$y = \varphi(t) \text{ and } dx = f'(t)dt.$$

Substituting in  $\int ydx$  gives

[597] 
$$A = \int \varphi(t) \cdot f'(t)dt.$$

**EXAMPLE.**—Find the area of the ellipse from the equations,

$$x = a \cos \varphi, \quad y = b \sin \varphi.$$

$$dx = -a \sin \varphi d\varphi.$$

When  $x = 0$ ,  $\varphi = \frac{\pi}{2}$ .

$$x = a, \quad \varphi = 0.$$

Then

$$A = \int_0^a ydx = \int_{\frac{\pi}{2}}^0 [b \sin \varphi (-a \sin \varphi) d\varphi] =$$

$$\int_0^{\frac{\pi}{2}} [ab \sin^2 \varphi d\varphi] = \frac{\pi ab}{4} = \text{area in one quadrant.}$$

$$\text{Total area} = 4 \times \frac{\pi ab}{4} = \pi ab.$$

## CHAPTER LIV

### REDUCTION METHODS FOR INTEGRATION

**1017. Elementary Forms.**—In preparing a function for integration, it is advisable to see if it is in the most convenient form. If the function is the sum of several terms, integrate term by term. If products or powers are involved, it is often best to perform the operations indicated before integrating. Fractions can often be divided out or written as negative powers. Radicals should be regarded as fractional powers.

To check the results of integration, simply differentiate the result obtained and compare with the function which was to be integrated. The two should be identical.

**EXAMPLE.**—Integrate.

$$\int x\sqrt{x^2 + a^2}dx = \frac{1}{2}\int 2x\sqrt{x^2 + a^2}dx = \frac{1}{2}\int (x^2 + a^2)^{\frac{1}{2}} 2x \cdot dx.$$

But  $2x$  is the differential coefficient of  $(x^2 + a^2)$ .

Assuming then that

$$(x^2 + a^2)^{\frac{1}{2}+1} \text{ is the integral}$$

and differentiating, we obtain

$$\frac{3}{2}(x^2 + a^2)^{\frac{1}{2}} 2x \cdot dx.$$

This is three times too large, and hence the required function is

$$\frac{1}{3}(x^2 + a^2)^{\frac{3}{2}}.$$

**1018. Integration by Expansion.**—Expressions are usually easier to integrate if they are first expanded.

**EXAMPLE.**—Find  $\int (a^2 + x^2)^3 dx$ .

$$\begin{aligned} \int (a^2 + x^2)^3 dx &= \int (a^6 + 3a^4x^2 + 3a^2x^4 + x^6) dx = \\ &= \int a^6 dx + 3\int a^4x^2 dx + 3\int a^2x^4 dx + \int x^6 dx = \\ &= a^6x + a^4x^3 + \frac{3}{2}a^2x^5 + \frac{1}{7}x^7. \end{aligned}$$

**1019. Fundamental Integration Forms.**—Since integration is the reverse operation from differentiation, we may at once tabulate some of the forms which we have learned by differentiating them. Also we will develop additional forms by the use of those already learned. Wherever a doubt exists as to the

correctness of a result, differentiate the result and see if the original function is obtained.

$$[598] \int u^n du = \frac{u^{n+1}}{n+1} + C.$$

$$[599] \int \frac{du}{u} = \log_e u + C.$$

$$[600] \int a^u du = \frac{a^u}{\log_e a} + C.$$

$$[601] \int e^u du = e^u + C.$$

$$[602] \int \cos u du = \sin u + C.$$

$$[603] \int \sin u du = -\cos u + C.$$

$$[604] \int \sec^2 u du = \tan u + C.$$

$$[605] \int \csc^2 u du = -\cot u + C.$$

$$[606] \int \sec u \cdot \tan u du = \sec u + C.$$

$$[607] \int \csc u \cdot \cot u du = -\csc u + C.$$

$$[608] \int \tan u du = \log (\sec u) + C.$$

$$[609] \int \cot u du = \log (\sin u) + C.$$

$$[610] \int \sec u du = \log (\sec u + \tan u) + C.$$

$$= \log \left[ \tan \left( \frac{\pi}{4} + \frac{u}{2} \right) \right] + C.$$

$$[611] \int \csc u du = \log (\csc u - \cot u) + C.$$

$$= \log \left[ \tan \left( \frac{u}{2} \right) \right] + C.$$

$$[612] \int \frac{du}{\sqrt{a^2 - u^2}} = \sin^{-1} \frac{u}{a} + C, \text{ or } -\cos^{-1} \frac{u}{a} + C.$$

$$[613] \int \frac{du}{a^2 + u^2} = \frac{1}{a} \tan^{-1} \frac{u}{a} + C, \text{ or } -\frac{1}{a} \cot^{-1} \frac{u}{a} + C.$$

$$[614] \int \frac{du}{u\sqrt{u^2 - a^2}} = \frac{1}{a} \sec^{-1} \frac{u}{a} + C, \text{ or } -\frac{1}{a} \csc^{-1} \frac{u}{a} + C.$$

$$[615] \int \frac{du}{u^2 - a^2} = \frac{1}{2a} \log \left( \frac{u-a}{u+a} \right) + C, \text{ or } \frac{1}{2a} \log \left( \frac{a-u}{a+u} \right) + C.$$

$$[616] \int \frac{du}{\sqrt{u^2 \pm a^2}} = \log (u + \sqrt{u^2 \pm a^2}) + C.$$

$$[617] \int \frac{du}{\sqrt{2ax - x^2}} = \text{vers}^{-1} \frac{x}{a} + C.$$

**1020. Integration by Introduction of New Variables.**—Given for integration,

$$\int f(x) dx,$$

and suppose that the corresponding function is  $F(x)$ ; then

$$\int f(x)dx = F(x), \quad (1)$$

or

$$f(x) = \frac{d}{dx}[F(x)]. \quad (2)$$

Now suppose

$$x = \varphi(u). \quad (3)$$

That is,  $x$  is some function of  $u$ .

Then  $f(x)$  and  $F(x)$  are both functions of  $u$  and we have a function of a function. From differential calculus,

$$\frac{d[F(x)]}{du} = \frac{d[F(x)]}{dx} \cdot \frac{dx}{du}. \quad [469] \quad (4)$$

But from (2),

$$\frac{d[F(x)]}{dx} = f(x),$$

which substituted in (4) gives

$$\frac{d[F(x)]}{du} = f(x) \frac{dx}{du}.$$

Integrating with respect to  $u$  gives

$$F(x) = \int f(x) \frac{dx}{du} du. \quad (5)$$

But from (1),

$$F(x) = \int f(x)dx,$$

which substituted in (5) gives

$$[618] \quad \int f(x) dx = \int f(x) \frac{dx}{du} du.$$

By substituting for  $x$  its value in terms of  $u$  from (3) during simplification, a convenient form for integration usually results.

EXAMPLE.—Find  $\int (a + bx)^n dx$ .

Let  $a + bx = u$ . Then  $x = \frac{u - a}{b}$ .

$$\frac{dx}{du} = \frac{1}{b}.$$

Hence from [618],

$$\int (a + bx)^n dx = \int u^n \frac{dx}{du} du = \frac{1}{b} \int u^n du = \frac{u^{n+1}}{b(n+1)}.$$

Substituting for  $u$  in terms of  $x$ ,

$$\int (a + bx)^n dx = \frac{(a + bx)^{n+1}}{b(n+1)} + C.$$



From this particular form, any function of the form  $(a + bx)^n$  can be readily integrated for any value of  $n$ .

$$\int (a + bx) dx = \frac{(a + bx)^2}{2b} + C.$$

$$\int (a + bx)^2 dx = \frac{(a + bx)^3}{3b} + C.$$

$$\int (a + bx)^3 dx = \frac{(a + bx)^4}{4b} + C.$$

$$\int \frac{dx}{(a + bx)^2} = \int (a + bx)^{-2} dx = \frac{(a + bx)^{-1}}{-b} = -\frac{1}{b(a + bx)} + C.$$

$$\int \frac{dx}{(a + bx)^3} = \int (a + bx)^{-3} dx = -\frac{1}{2b(a + bx)^2} + C.$$

The integral,  $\int (a - bx)^n dx$ , may be treated in the same way by substituting  $a - x = u$ , and then

$$\int (a - bx)^n dx = -\frac{(a - bx)^{n+1}}{b(n+1)} + C.$$

$$\int (a - bx) dx = -\frac{(a - bx)^2}{2b} + C.$$

$$\int (a - bx)^2 dx = -\frac{(a - bx)^3}{3b} + C.$$

$$\int \frac{dx}{(a - bx)^2} = -\frac{(a - bx)^{-1}}{-b} + C = \frac{1}{b(a - bx)} + C.$$

$$\int \frac{dx}{(a - bx)^3} = -\frac{(a - bx)^{-2}}{-2b} + C = \frac{1}{2b(a - bx)^2} + C.$$

The exceptional case is when  $n = -1$  and the integral in both cases reduces to logarithmic forms.

Take

$$\int \frac{dx}{a + bx}.$$

Put  $a + bx = u$ . Then  $x = \frac{u - a}{b}$  and  $\frac{dx}{du} = \frac{1}{b}$ .

Substituting in [618] above,

$$\int \frac{dx}{a + bx} = \frac{1}{b} \int \frac{du}{u} = \frac{1}{b} \log u + C = \frac{1}{b} \log (a + bx) + C.$$

In the same manner, consider  $\int \frac{A dx}{a + bx}$ .

Put  $a + bx = u$ . Then  $x = \frac{u - a}{b}$  and  $\frac{dx}{du} = \frac{1}{b}$ .

Substituting in [618] above,

$$\int \frac{A dx}{a + bx} = \frac{A}{b} \int \frac{du}{u} = \frac{A}{b} \log u = \frac{A}{b} \log (a + bx) + C.$$

EXAMPLE.—Determine the integral  $\int e^{nx} dx$ .

Let  $nx = u$ .

Then  $x = \frac{u}{n}$  and  $\frac{dx}{du} = \frac{1}{n}$ .

From [618],

$$\int e^{nx} dx = \int e^u \cdot \frac{1}{n} du = \frac{1}{n} \int e^u du = \frac{1}{n} e^u = \frac{1}{n} e^{nx}.$$

From this, the integral

$$\int e^{3x} dx = \frac{1}{3} e^{3x}.$$

EXAMPLE.—Find  $\int \tan x dx$ .

Write  $\int \tan x dx = \int \frac{\sin x}{\cos x} dx$ .

Put  $\cos x = u$ . Then  $x = \cos^{-1} u$ ,

whence

$$\frac{dx}{du} = -\frac{1}{\sqrt{1-u^2}} = -\frac{1}{\sqrt{1-\cos^2 x}} = -\frac{1}{\sin x}.$$

Then

$$\begin{aligned} \int \frac{\sin x}{\cos x} dx &= \int \frac{\sin x}{\cos x} \left( -\frac{1}{\sin x} \right) du = -\int \frac{du}{\cos x} = -\int \frac{du}{u}. \\ &= -\log u + C. \end{aligned}$$

Therefore,

$$\int \tan x dx = -\log (\cos x) + C = \log \frac{1}{\cos x} + C.$$

In a similar manner,

$$\int \cot x dx = \log (\sin x) + C.$$

EXAMPLE.—Given  $\int (x^2 - 5x)(2x - 5) dx$ .

Let  $x^2 - 5x = u$ .

Then  $2x dx - 5 dx = du$ .

$$\frac{dx}{du} = \frac{1}{2x - 5}.$$

$$\int (x^2 - 5x)(2x - 5) dx = \int \frac{(x^2 - 5x)(2x - 5)}{(2x - 5)} du = \int u du = \frac{u^2}{2}.$$

But  $u = x^2 - 5x$ .

Then

$$\int (x^2 - 5x)(2x - 5) dx = \frac{1}{2} (x^2 - 5x)^2.$$

EXAMPLE.—Given  $\int e^x \cos e^x dx$ .

Let  $e^x = u$ .

$x \log e = \log u$ .

$$x = \frac{\log u}{\log e} = \log u, \text{ and } \frac{dx}{du} = \frac{1}{u} = \frac{1}{e^x}.$$

$$\begin{aligned} \int e^x \cos e^x dx &= \int e^x \cos e^x \cdot \frac{1}{e^x} du = \int \cos e^x du = \int \cos u du. \\ &= \sin e^x + C. \end{aligned}$$

**1021. Integration by Parts.**—From the differentiation of a product,

$$\frac{d}{dx}(uv) = v\frac{du}{dx} + u\frac{dv}{dx}.$$

Then by integration,

$$uv = \int v\frac{du}{dx}dx + \int u\frac{dv}{dx}dx,$$

which is the reverse of the differential form.

By writing the above in a transformed form, we have a very useful formula for integration.

$$[619] \quad \int u\frac{dv}{dx}dx = uv - \int v\frac{du}{dx}dx.$$

The method of using this formula is to determine functions  $u$  and  $v$  so that the product,

$$u\frac{dv}{dx} = f(x),$$

that is, equals the function given for integration. If the formula is put into the differential form, then

$$[620] \quad \int u dv = uv - \int v du.$$

If a quantity to be integrated is separated into two factors  $u$  and  $dv$ , the integral is found from the formula.

EXAMPLE.—Find  $\int x \log x dx$ .

Let  $\log x = u$ . Then  $du = \frac{1}{x} dx$ .

Let  $x dx = dv$ . Then  $v = \frac{x^2}{2}$ .

Substituting in formula,

$$\begin{aligned} \int x \cdot \log x dx &= \frac{x^2}{2} \cdot \log x - \int \frac{x^2}{2} \cdot \frac{1}{x} dx = \frac{x^2}{2} \cdot \log x - \frac{1}{2} \int x dx \\ &= \frac{x^2}{2} \cdot \log x - \frac{1}{4}x^2 + C. \end{aligned}$$

To make this clear, note

$$\begin{array}{ccc} (dv) & (u) & (v) (du) \\ \int x \log x \cdot dx &= \log x \cdot \frac{x^2}{2} - \int \frac{x^2}{2} \cdot \frac{1}{x} dx. \end{array}$$

EXAMPLE.—Find  $\int \sin^2 x dx$ .

Let  $u = \sin x$ . Then  $du = \cos x dx$ .

Let  $dv = \sin x dx$ . Then  $v = -\cos x$ .

Substituting in the formula for integration by parts,

$$\int \sin^2 x dx = -\sin x \cdot \cos x + \int \cos^2 x dx. \quad (1)$$

But  $\cos^2 x = 1 - \sin^2 x$ .

Therefore,

$$\int \cos^2 x dx = \int dx - \int \sin^2 x dx = x - \int \sin^2 x dx. \quad (2)$$

Substituting in (1).

$$\int \sin^2 x dx = -\sin x \cdot \cos x + x - \int \sin^2 x dx.$$

Transposing  $\int \sin^2 x dx$ ,

$$2 \int \sin^2 x dx = x - \sin x \cdot \cos x.$$

$$\therefore \int \sin^2 x dx = \frac{x}{2} - \frac{\sin x \cdot \cos x}{2} + C.$$

EXAMPLE.—Find  $\int e^{ax} \sin nx dx$  and  $\int e^{ax} \cos nx dx$ .

Let  $u = \sin nx$ . Then  $du = n \cos nx dx$ .

Let  $dv = e^{ax}$ . Then  $v = \frac{e^{ax}}{a}$ .

Substituting in

$$\int e^{ax} \sin nx dx = uv - \int v du$$

gives

$$\int e^{ax} \sin nx dx = \frac{e^{ax}}{a} \sin nx - \int \frac{e^{ax}}{a} n \cos nx dx.$$

A second integration by parts with

$$u = \cos nx. \quad du = -n \sin nx dx$$

$$dv = e^{ax} dx. \quad v = \frac{e^{ax}}{a}$$

gives

$$\frac{n}{a} \int e^{ax} \cos nx dx = \frac{e^{ax}}{a^2} n \cdot \cos nx + \int \frac{e^{ax}}{a^2} n^2 \sin nx dx.$$

Therefore,

$$\int e^{ax} \sin nx dx = \frac{e^{ax}}{a} \sin nx - \frac{e^{ax}}{a^2} n \cdot \cos nx - \frac{n^2}{a^2} \int e^{ax} \sin nx dx.$$

The last term of the second member is equal to the first member multiplied by  $\frac{n^2}{a^2}$ . Therefore, by transposing,

$$\begin{aligned} \frac{n^2 + a^2}{a^2} \int e^{ax} \sin nx dx &= \frac{e^{ax}}{a} \sin nx - \frac{e^{ax}}{a^2} n \cdot \cos nx. \\ &= \frac{e^{ax}}{a^2} (a \sin nx - n \cdot \cos nx). \end{aligned}$$

Therefore,

$$\int e^{ax} \sin nx dx = \frac{e^{ax}}{a^2 + n^2} (a \sin nx - n \cos nx) + C.$$

In the same manner,

$$\int e^{ax} \cos nx dx = \frac{e^{ax}}{a^2 + n^2} (n \sin nx + a \cos nx) + C.$$

**1022. Integration by Transformation of Function to Be Integrated.**—It frequently happens that a function can be transformed into a form which has been previously integrated.

EXAMPLE.—Find  $\int \frac{x^2 - 1}{x} dx$ .

$$\begin{aligned} \int \frac{x^2 - 1}{x} dx &= \int \left( x - \frac{1}{x} \right) dx = \int x dx - \int \frac{1}{x} dx \\ &= \frac{x^2}{2} - \log x + C. \end{aligned}$$

EXAMPLE.—If  $\frac{dy}{dx} = x$ , or in differential form,  $dy = x dx$ , then

$$\begin{aligned} y &= \int x dx \\ &= \frac{1}{2} \int 2x dx \\ &= \frac{x^2}{2} + C. \end{aligned}$$

EXAMPLE.—If  $dy = x\sqrt{1 - x^2} dx$ , then

$$\begin{aligned} y &= \int x(1 - x^2)^{\frac{1}{2}} dx = -\frac{1}{2} \cdot \frac{2}{3} \int (1 - x^2)^{\frac{1}{2}} (-2x) dx \\ &= -\frac{(1 - x^2)^{\frac{3}{2}}}{3} + C. \end{aligned}$$

This amounts to putting the function into the form,

$$\int u^n du,$$

with  $(1 - x^2)^{\frac{1}{2}} = u$ , and  $(-2x dx) = du$ , since

$$d(1 - x^2) = -2x dx.$$

By transforming as above, this relation was obtained.

**1023. Integration by Inspection.**—If the function to be integrated can be separated by inspection into two factors, one of which is the derivative of the other, then the integral is equal to one-half the square of the latter factor, for

[621] 
$$\int u \frac{du}{dx} dx = \frac{u^2}{2} + C.$$

EXAMPLE.—Find  $\int (x^3 + 2x)(3x^2 + 2) dx$ .

Now  $(3x^2 + 2) dx$  is the differential of  $(x^3 + 2x)$ . Therefore, the integral is

$$\left( \frac{u^2}{2} \right), \text{ or } \frac{(x^3 + 2x)^2}{2}.$$

Or

$$\int (x^3 + 2x)(3x^2 + 2) dx = \frac{(x^3 + 2x)^2}{2} + C.$$

EXAMPLE.—Find  $\int \sin x \cdot \cos x dx$ .

$\cos x$  is the derivative of  $\sin x$  and the function therefore takes the form,

$$\int u \frac{du}{dx} dx = \frac{u^2}{2} + C.$$

Then

$$\int \sin x \cdot \cos x dx = \frac{\sin^2 x}{2} + C.$$

A more general form for this same relation is

$$\int u^n \frac{du}{dx} dx = \frac{u^{n+1}}{n+1} + C.$$

EXAMPLE.—Find  $\int x(a^2 + x^2)^{\frac{1}{2}} dx$ .

Let  $a^2 + x^2 = u$ . Then  $du = 2x \cdot dx$ .

Then

$$\begin{aligned} \frac{1}{2} \int 2x(a^2 + x^2)^{\frac{1}{2}} dx &= \frac{1}{2} \int u^{\frac{1}{2}} du = \frac{1}{2} \int u^{\frac{1}{2}} \frac{du}{dx} dx \\ &= \frac{1}{2} \left( \frac{u^{\frac{3}{2}}}{\frac{3}{2}} \right) = \frac{u^{\frac{3}{2}}}{7} = \frac{(a^2 + x^2)^{\frac{3}{2}}}{7}. \end{aligned}$$

Many integrals can be written immediately from the laws of differential calculus since integration is the reverse operation from differentiation. If a function is to be integrated, an attempt should first be made to reduce it to some form which is recognizable as the differential of some known function. If this method does not lead to a solution, try some of the other schemes which follow to find the integral.

Some of the fundamental forms of integration to which the function may be compared are as follows:

$$\int u^n du = \frac{u^{n+1}}{n+1} + C \quad (\text{If } n \neq -1). \quad (1)$$

EXAMPLE.—Find  $\int x^{\frac{1}{2}} dx$ .

$$\int x^{\frac{1}{2}} dx = \frac{2}{3} x^{\frac{3}{2}} + C.$$

EXAMPLE.—Find  $\int x^{-1.63} dx$ .

$$\int x^{-1.63} dx = -\frac{x^{-0.63}}{0.63} + C.$$

Special cases of  $\int u^n du$  are (2), (3), and (4) below.

$$\int (ax^m + b)^n x^{m-1} dx = \frac{1}{ma} (ax^m + b)^{n+1} + C. \quad (2)$$

Examples of this form are

$$\int \sqrt{x^4 + 63(x^3)} dx, \int (2x^2 + 5)^5 dx, \text{ and } \int \frac{x}{x^2 + 25} dx.$$

$$\int \sin^n x \cdot \cos x dx = \frac{1}{n+1} \sin^{n+1} x + C, \quad (3)$$

as  $\int \sin^3 x \cdot \cos x dx$ .

$$\int \cos^n x \cdot \sin x dx = -\frac{1}{n+1} \cos^{n+1} x + C, \quad (4)$$

as  $\int \cos^3 x \cdot \sin x dx$ , or

$$\int \frac{\sin x dx}{\cos^2 x}, \text{ which is } \int \cos^{-2} x \cdot \sin x dx.$$

**1024. Inspection for Logarithmic Form.**—If the function to be integrated can be written as a fraction whose numerator is the derivative of the denominator, then the integral sought is the logarithm of the denominator, for

$$\int \frac{du}{u} = \log u + C.$$

EXAMPLE.—Find  $\int \frac{e^x}{e^x + 5} \cdot dx$ .

The derivative of  $(e^x + 5)$  is  $e^x$ . Therefore,

$$\int \frac{e^x \cdot dx}{e^x + 5} = \log (e^x + 5) + C.$$

EXAMPLE.—Find  $\int \frac{2x}{5 + x^2} dx$ .

The derivative of  $5 + x^2$  is  $2x$ . Therefore,

$$\int \frac{2x}{5 + x^2} = \log (5 + x^2) + C.$$

EXAMPLE.—Find  $\int \frac{3x^2 - 5}{x^3 - 5x} dx$ .

The derivative of  $x^3 - 5x$  is  $3x^2 - 5$ . Therefore,

$$\int \frac{3x^2 - 5}{x^3 - 5x} dx = \log (x^3 - 5x) + C.$$

It will be seen from the foregoing that success in integrating a function depends upon trying different schemes of reducing the function to some known form which may be easily recognized as the differential of a known integral. By trying different relations, one may be found which corresponds in form to the given function in which case the integral is known.

1025. Logarithmic Form  $\int \frac{dx}{u} \frac{du}{dx} dx$ , or  $\int \frac{du}{u}$  [622].

$$\int \frac{du}{u} = \log u + C, \quad (5)$$

as  $\int \frac{2x}{x^2} dx = \log x^2 + C$  ( $dx^2 = 2x dx$ ).

Special log forms:

$$\int \frac{x^{m-1} dx}{ax^m + b} = \frac{1}{ma} \log(ax^m + b) + C, \quad (6)$$

as  $\int \frac{x^3 dx}{3x^4 - 5} = \frac{1}{3 \cdot 4} \log(3x^4 - 5) + C$ .

$$\int \cot ax dx = \int \frac{\cos ax}{\sin ax} dx = \frac{1}{a} \log \sin ax + C. \quad (7)$$

$$\int \tan ax dx = \int \frac{\sin ax}{\cos ax} dx = -\frac{1}{a} \log \cos ax + C. \quad (8)$$

$$\int \sec ax dx = \int \frac{(\sec^2 ax + \sec ax \cdot \tan ax)}{\sec ax + \tan ax} dx. \quad (9)$$

$$= \frac{1}{a} \log(\sec ax + \tan ax) + C.$$

$$\int \csc ax dx = +\frac{1}{a} \log(\csc ax - \cot ax) + C. \quad (10)$$

1026. Form  $\int x^m(a + bx^n)^p dx$ .—Binomial differentials, as [623]

$$\int x^m(a + bx^n)^p dx,$$

are also integrated by the formula for integration by parts. The following are the four principal reduction formulae which reduce the expression to a simpler form or to one having a more convenient value for  $m$  or  $p$ :

$$\int x^m(a + bx^n)^p dx = \frac{x^{m-n+1}(a + bx^n)^{p+1}}{(np + m + 1)b} - \frac{(m - n + 1)a}{(np + m + 1)b} \int x^{m-n}(a + bx^n)^p dx. \quad (1)$$

The above formula diminishes the power  $m$  by  $n$  but fails when  $(np + m + 1) = 0$ .

$$\int x^m(a + bx^n)^p dx = \frac{x^{m+1}(a + bx^n)^p}{np + m + 1} + \frac{anp}{np + m + 1} \int x^m(a + bx^n)^{p-1} dx. \quad (2)$$

This formula reduces the exponent  $p$  by unity but fails when  $(np + m + 1) = 0$ .

$$\int x^m(a + bx^n)^p dx = \frac{x^{m+1}(a + bx^n)^{p+1}}{(m+1)a} - \frac{(np + n + m + 1)b}{(m+1)a} \int x^{m+n}(a + bx^n)^p dx. \quad (3)$$



This formula increases the exponent  $m$  by  $n$ . It is useful when  $m$  is negative. It fails when  $(m + 1) = 0$ .

$$\int x^m (a + bx^n)^p dx = -\frac{x^{m+1}(a + bx^n)^{p+1}}{n(p+1)a} + \frac{(np + n + m + 1)}{n(p+1)a} \int x^m (a + bx^n)^{p+1} dx. \quad (4)$$

This formula increases the exponent  $p$  by unity. It fails when  $(p + 1) = 0$ .

EXAMPLE.—Find  $\int \frac{x^2 dx}{\sqrt{a^2 - x^2}}$ .

By applying (1), the integral reduces to  $\int \frac{dx}{\sqrt{a^2 - x^2}}$ , which is readily solvable.

$$\int \frac{x^2 dx}{\sqrt{a^2 - x^2}} = \int x^2 (a^2 - x^2)^{-1/2} dx.$$

Then  $m = 2$ ,  $n = 2$ ,  $p = -\frac{1}{2}$ ,  $a = a^2$ ,  $b = -1$ .

$$\begin{aligned} \therefore \int x^2 (a^2 - x^2)^{-1/2} dx &= -\frac{x(a^2 - x^2)^{1/2}}{2} + \frac{a^2}{2} \int \frac{dx}{\sqrt{a^2 - x^2}} \\ &= -\frac{x\sqrt{a^2 - x^2}}{2} + \frac{a^2}{2} \sin^{-1} \frac{x}{a}. \end{aligned}$$

**1027. Trigonometric Reduction Formulae.**—By means of the integration by parts formula, the following trigonometric formulae are obtained. They will be found to be very useful time savers.

$$[624] \quad \int \tan^n x dx = \frac{\tan^{n-1} x}{n-1} - \int \tan^{n-2} x dx.$$

$$[625] \quad \int \cot^n x dx = -\frac{\cot^{n-1} x}{n-1} - \int \cot^{n-2} x dx.$$

$$[626] \quad \int \sin^m x \cdot \cos^n x dx = -\frac{\sin^{m-1} x \cdot \cos^{n+1} x}{m+n} + \frac{m-1}{m+n} \int \sin^{m-2} x \cdot \cos^n x dx.$$

$$[627] \quad \int \sin^m x \cdot \cos^n x dx = \frac{\sin^{m+1} x \cdot \cos^{n-1} x}{m+n} + \frac{n-1}{m+n} \int \sin^m x \cdot \cos^{n-2} x dx.$$

$$[628] \quad \int \frac{\cos^n x}{\sin^m x} dx = -\frac{\cos^{n+1} x}{(m-1)\sin^{m-1} x} - \frac{n-m+2}{m-1} \int \frac{\cos^n x dx}{\sin^{m-2} x}$$

$$[629] \quad \int \frac{\cos^n x}{\sin^m x} dx = \frac{\cos^{n-1} x}{(n-m)\sin^{m-1} x} + \frac{n-1}{n-m} \int \frac{\cos^{n-2} x dx}{\sin^m x}$$

$$[630] \quad \int \sin^m x dx = -\frac{\sin^{m-1} x \cdot \cos x}{m} + \frac{m-1}{m} \int \sin^{m-2} x dx.$$

$$[631] \quad \int \cos^n x dx = \frac{\cos^{n-1} x \cdot \sin x}{n} + \frac{n-1}{n} \int \cos^{n-2} x dx.$$

$$[632] \int \frac{dx}{\sin^m x} = -\frac{\cos x}{(m-1)\sin^{m-1} x} + \frac{m-2}{m-1} \int \frac{dx}{\sin^{m-2} x}.$$

$$[633] \int \frac{dx}{\cos^n x} = \frac{\sin x}{(n-1)\cos^{n-1} x} + \frac{n-2}{n-1} \int \frac{dx}{\cos^{n-2} x}.$$

1028. Forms  $\int \frac{dx}{ax^2 + bx + c}$  and  $\int \frac{Ax + B}{ax^2 + bx + c} dx$ .

By dividing both the numerator and the denominator by  $a$  and completing the square, the first expression can be put into the form,

$$\frac{1}{a} \int \frac{dx}{\left(x + \frac{b}{2a}\right)^2 - \frac{b^2 - 4ac}{4a^2}}.$$

Now let  $x + \frac{b}{2a} = u$ . Then  $du = dx$  and

$$\int \frac{dx}{ax^2 + bx + c} = \frac{1}{a} \int \frac{du}{u^2 - \frac{b^2 - 4ac}{4a^2}}.$$

If  $b^2 - 4ac$  is negative,

$$[634] \int \frac{dx}{ax^2 + bx + c} = \frac{2}{\sqrt{4ac - b^2}} \tan^{-1} \frac{2ax + b}{\sqrt{4ac - b^2}}.$$

If  $b^2 - 4ac$  is positive,

$$[635] \int \frac{dx}{ax^2 + bx + c} = \frac{1}{\sqrt{b^2 - 4ac}} \log \frac{2ax + b - \sqrt{b^2 - 4ac}}{2ax + b + \sqrt{b^2 - 4ac}}.$$

If  $b^2 - 4ac = 0$ ,

$$[636] \int \frac{dx}{ax^2 + bx + c} = -\frac{2}{2ax + b}.$$

$$[637] \quad \text{Form } \int \frac{Ax + B}{ax^2 + bx + c} dx.$$

An illustrating example will make the method clear.

EXAMPLE.—Find  $\int \frac{3x + 5}{x^2 + 6x + 11} dx$ .

$$\int \frac{3x + 5}{x^2 + 6x + 11} dx = \int \frac{3(x + 3) - 4}{(x + 3)^2 + 2} dx = 3 \int \frac{(x + 3) dx}{(x + 3)^2 + 2} - 4 \int \frac{dx}{(x + 3)^2 + 2}.$$

$\frac{3}{2} \int \frac{2(x + 3) dx}{(x + 3)^2 + 2}$  is of the form,

$$\int \frac{du}{u} = \log u \text{ [599]} = \frac{3}{2} \log [(x + 3)^2 + 2],$$

and

$$-4 \int \frac{dx}{(x+3)^2 + 2} \text{ is of the form,}$$

$$\int \frac{du}{a^2 + u^2} \text{ [613], where } u = x + 3 \text{ and } a = \sqrt{2}, \text{ and } -4 \frac{dx}{(x+3)^2 + 2}$$

$$= -\frac{4}{\sqrt{2}} \tan^{-1} \frac{x+3}{\sqrt{2}}.$$

Therefore,

$$\int \frac{3x+5}{x^2+6x+11} dx = \frac{3}{2} \log [(x+3)^2 + 2] - \frac{4}{\sqrt{2}} \tan^{-1} \frac{x+3}{\sqrt{2}}.$$

**1029. Integrals Containing Fractional Powers of  $x$  or of  $(a + bx)$ .**—If fractional powers of a single linear expression,  $a + bx$ , appear after the integral sign, then let

$$a + bx = z^n,$$

when  $n$  = least common denominator of the exponents of  $a + bx$ .

EXAMPLE.—Find  $\int \frac{(x+2)^{\frac{1}{2}} + 4}{(x+2)^{\frac{1}{2}} - 3} dx$ .

Let  $(x+2)$  (the linear expression) =  $z^4$ .

Then  $\int \frac{(x+2)^{\frac{1}{2}} + 4}{(x+2)^{\frac{1}{2}} - 3} dx = 4 \int \frac{(z^2 + 4)z^3}{z^2 - 3} dz$ .

Divide the numerator by the denominator and the integration is readily performed. After integrating, replace  $z$  by  $(x+2)^{\frac{1}{4}}$ .

In the same manner for fractional powers of  $x$ , use  $z$  to a power equal to the least common denominator of the exponents of  $x$ .

EXAMPLE.—Find  $\int \frac{x^{\frac{1}{2}} - x^{\frac{1}{4}}}{x^{\frac{1}{2}} + 4} dx$ .

Let  $x = z^6$ . Then  $dx = 6z^5 dz$  and

$$\int \frac{x^{\frac{1}{2}} - x^{\frac{1}{4}}}{x^{\frac{1}{2}} + 4} dx = 6 \int \frac{z^3 - z^2}{z^2 + 4} z^5 dz = 6 \int \frac{z^8 - z^7}{z^2 + 4} dz.$$

Divide the numerator by the denominator as before, until the degree of the remainder is small enough to integrate. After integrating, replace  $z$  by  $x^{\frac{1}{6}}$ .

This is a case of the preceding with  $a = 0$ ,  $b = 1$ .

**1030. Integration by Trigonometric Substitution.**—Expressions containing  $\sqrt{a^2 - x^2}$  or  $\sqrt{x^2 \pm a^2}$  can be replaced by trigonometric equivalents.

When  $\sqrt{a^2 - x^2}$  occurs, let  $x = a \sin \varphi$ .

When  $\sqrt{a^2 + x^2}$  occurs, let  $x = a \tan \varphi$ .

When  $\sqrt{x^2 - a^2}$  occurs, let  $x = a \sec \varphi$ .

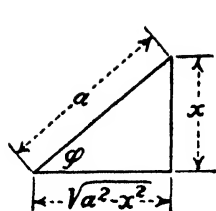

FIG. 606.

Then

$$\sqrt{a^2 - x^2} \text{ becomes } a \cos \varphi.$$

$$\sqrt{a^2 + x^2} \text{ becomes } a \sec \varphi.$$

$$\sqrt{x^2 - a^2} \text{ becomes } a \tan \varphi.$$

Since, in a right triangle with  $x$  opposite the angle  $\varphi$  and  $a$  equal to the hypotenuse,

$$\sin \varphi = \frac{x}{a} \text{ and } \tan \varphi = \frac{x}{\sqrt{a^2 - x^2}}.$$

The other functions of the angle  $\varphi$  may be determined by reference to the triangle of Fig. 606.

EXAMPLE.—Find  $\int \sqrt{a^2 - x^2} dx$ .

Let  $x = a \sin \varphi$ . Then  $dx = a \cos \varphi d\varphi$ .

$$\int \sqrt{a^2 - x^2} dx = \int a \cos \varphi \times a \cos \varphi d\varphi = \int a^2 \cos^2 \varphi d\varphi.$$

Integrate by parts. From Art. 1021,

$$\int \cos^2 \varphi d\varphi = \frac{\varphi + \frac{1}{2} \sin 2\varphi}{2}.$$

Then

$$\begin{aligned} \int a^2 \cos^2 \varphi d\varphi &= \frac{a^2}{2} \left( \varphi + \frac{1}{2} \sin 2\varphi \right) + C. \\ &= \frac{a^2}{2} \left( \sin^{-1} \frac{x}{a} + \sin \varphi \cdot \cos \varphi \right) + C. \\ &= \frac{a^2}{2} \left[ \sin^{-1} \frac{x}{a} + \frac{x}{a^2} \sqrt{a^2 - x^2} \right] + C. \end{aligned}$$

$$\int \sqrt{a^2 - x^2} dx = \frac{a^2}{2} \sin^{-1} \frac{x}{a} + \frac{x}{2} \sqrt{a^2 - x^2} + C.$$

1031. Plotting Functions of  $\sqrt{a^2 - x^2}$ , or  $\sqrt{x^2 \pm a^2}$ .—From the relations between the elements of the triangles of Fig. 607, and by constructing triangles in which  $a$  has a fixed value and  $x$  has a series of values, the values of the functions,

$$\sqrt{a^2 - x^2} \text{ and } \sqrt{x^2 \pm a^2},$$

can be obtained graphically and plotted as ordinates. The curve can then be constructed and integrated very quickly.

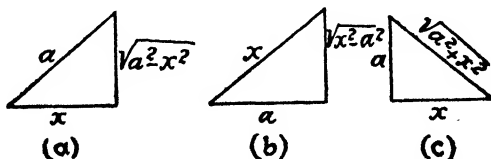

FIG. 607.

**EXAMPLE.**—If  $a = 6$  and we desire  $\sqrt{a^2 + x^2}$ , make  $OA = 6$ . Draw  $OX \perp$  to  $OA$  and by taking  $x = 0, x = 1, x = 2, x = 3$ , etc., the length of the hypotenuse gives the values of  $\sqrt{a^2 + x^2}$  for each value of  $x$  (Fig. 608).

Transfer these hypotenuses as ordinates and draw a curve through the terminal points. This curve is the graph of  $\sqrt{a^2 + x^2}$  for  $a = 6$ , or of  $\sqrt{36 + x^2}$ . This curve can be graphically integrated.

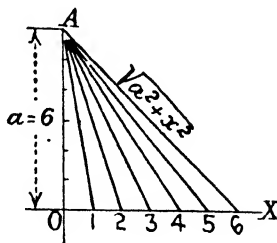

FIG. 608.

**1032. Quadratic Expressions.**— $ax^2 + bx + c$ , if under a radical, can be reduced to a binomial form such as  $a(t^2 + k)$  by completing the square. This form can be solved by trigonometric substitution as in the previous article.

$$ax^2 + bx + c = a \left[ \left( x^2 + \frac{b}{a}x + \frac{b^2}{4a^2} \right) + \left( \frac{c}{a} - \frac{b^2}{4a^2} \right) \right].$$

The right member is in binomial form. Now let

$$x + \frac{b}{2a} = t.$$

If the quadratic is not under a radical, solve as a binomial.

**1033. Integration of Rational Fractions.**—A rational fraction in  $x$  is a fraction whose numerator and denominator are polynomials in  $x$ . If the degree of the numerator is equal to, or greater than, the degree of the denominator, the fraction should be reduced by dividing the numerator by the denominator.

**EXAMPLE.**—Find  $\int \frac{x^4 + 3x^3}{x^2 + 2x + 1} dx$ .

$$\frac{x^4 + 3x^3}{x^2 + 2x + 1} = x^2 + x - 3 + \frac{5x + 3}{x^2 + 2x + 1}.$$

Then

$$\int \frac{x^4 + 3x^3 dx}{x^2 + 2x + 1} = \int x^2 dx + \int x dx - \int 3 dx + \int \frac{(5x + 3) dx}{x^2 + 2x + 1}.$$

The integration of the last term may be accomplished by the method given in Art. 1028 [637].

**1034. Integration by Partial Fractions.**—In the algebra section (Art. 499), a fraction was shown transformed into a sum of fractions with factors of the denominator of the given fraction

as denominators of the partial fractions. In the examples as given in Art. 499,

$$\frac{5x^2 - x - 24}{(x^2 - 1)(x + 3)(x + 4)} = \frac{x - 2}{x^2 - 1} + \frac{3}{x + 3} - \frac{4}{x + 4}.$$

If our problem was to integrate this fraction, then

$$\begin{aligned} \int \frac{5x^2 - x - 24}{(x^2 - 1)(x + 3)(x + 4)} dx &= \int \frac{x - 2}{x^2 - 1} dx + \int \frac{3}{x + 3} dx - \int \frac{4}{x + 4} dx. \\ &= \int \frac{x dx}{x^2 - 1} + \int \frac{-2 dx}{x^2 - 1} + \int \frac{3}{x + 3} dx - \int \frac{4}{x + 4} dx. \\ &= \frac{1}{2} \log(x^2 - 1) - \log \frac{x - 1}{x + 1} + 3 \log(x + 3) - 4 \log(x + 4). \end{aligned}$$

EXAMPLE.—Find  $\int \frac{(2x + 3)}{x^3 + x^2 - 2x} dx$ .

The factors of the denominator being  $(x)$ ,  $(x - 1)$ ,  $(x + 2)$ , we assume

$$\frac{2x + 3}{x(x - 1)(x + 2)} = \frac{A}{x} + \frac{B}{x - 1} + \frac{C}{x + 2}.$$

Clearing of fractions,

$$2x + 3 = A(x - 1)(x + 2) + Bx(x + 2) + Cx(x - 1).$$

Equating the coefficients of like powers and solving,

$$A = -\frac{3}{2}, B = \frac{5}{3}, C = -\frac{1}{6}.$$

Substituting these values,

$$\begin{aligned} \frac{2x + 3}{x(x - 1)(x + 2)} &= -\frac{3}{2x} + \frac{5}{3(x - 1)} - \frac{1}{6(x + 2)}. \\ \int \frac{(2x + 3) dx}{x(x - 1)(x + 2)} &= -\frac{3}{2} \int \frac{dx}{x} + \frac{5}{3} \int \frac{dx}{x - 1} - \frac{1}{6} \int \frac{dx}{x + 2}. \\ &= -\frac{3}{2} \log x + \frac{5}{3} \log(x - 1) - \frac{1}{6} \log(x + 2) + C. \\ &= \log \frac{C(x - 1)^{\frac{5}{3}}}{x^{\frac{3}{2}}(x + 2)^{\frac{1}{6}}}. \end{aligned}$$

**1035. Successive Integration.**—In the differential calculus we found a use for *successive derivatives* which we obtained by differentiating the derivative successively. In integration, we have the reverse operation.

EXAMPLE.—Find  $y$ , when  $\frac{d^3y}{dx^3} = 8x$ .

Then

$$\frac{d\left(\frac{d^2y}{dx^2}\right)}{dx} = 8x, \text{ or } d\left(\frac{d^2y}{dx^2}\right) = 8x dx.$$

Integrating,

$$\frac{d^2y}{dx^2} = \int 8x dx = 4x^2 + C_1.$$

But  $\frac{d^2y}{dx^2}$  may be written  $\frac{d\left(\frac{dy}{dx}\right)}{dx}$ . Then

$$\frac{d\left(\frac{dy}{dx}\right)}{dx} = 4x^2 + C_1, \text{ or } d\left(\frac{dy}{dx}\right) = (4x^2 + C_1)dx.$$

Integrating,  $\frac{dy}{dx} = \int (4x^2 + C_1)dx$ .

$$= \frac{4}{3}x^3 + C_1x + C_2.$$

Or

$$dy = \left(\frac{4}{3}x^3 + C_1x + C_2\right)dx.$$

Integrating again,

$$\begin{aligned} y &= \int \left(\frac{4}{3}x^3 + C_1x + C_2\right)dx. \\ &= \frac{1}{3}x^4 + \frac{C_1x^2}{2} + C_2x + C_3. \end{aligned}$$

This last result is also written in the form,

$$y = \int \int \int 8x \, dx \, dx \, dx.$$

When two integrations are performed, the form is

$$y = \int \int f(x) \, dx \, dx.$$

If no limits are assigned, the integral is indefinite.

EXAMPLE.—The acceleration of a moving point is constant and equal to  $a$ . Find the expression for the distance  $s$  traversed.

$$\text{Acceleration } a = \frac{d^2s}{dt^2}.$$

Then

$$\frac{d\left(\frac{ds}{dt}\right)}{dt} = a, \text{ or } d\left(\frac{ds}{dt}\right) = a \, dt.$$

$$\frac{ds}{dt} = \int a \, dt = at + C_1.$$

Then

$$ds = (at + C_1)dt.$$

Integrating again,

$$s = \int (at + C_1)dt = \frac{a}{2}t^2 + C_1t + C_2.$$

## CHAPTER LV

### SUMMATION METHOD

**1036. Summation Theorem.**—Let  $y$  be any quantity which varies continuously with  $x$  and let  $y_1, y_2, y_3, \dots, y_n$  be values of the function at intervals  $\Delta x_i$ , not necessarily equal, from  $x = a$  to  $x = b$ .

Multiply each of these values  $y_i$  by  $\Delta x_i$  and form the sum of these products. Then

$$y_1\Delta x_1 + y_2\Delta x_2 + y_3\Delta x_3 + y_4\Delta x_4 + \dots + y_n\Delta x_n.$$

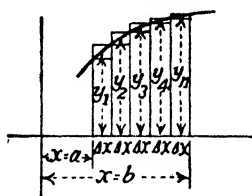

FIG. 609.

Now if the number of the strips in the interval from  $x = a$  to  $x = b$  is allowed to increase without limit in such a way that all the widths  $\Delta x_i$  approach 0, then this sum approaches as a limit the definite integral

$$\int_a^b y dx,$$

or

$$[638] \quad \lim_{\substack{\Delta x \rightarrow 0 \\ n \rightarrow \infty}} \left[ y_1\Delta x_1 + y_2\Delta x_2 + y_3\Delta x_3 + \dots + y_n\Delta x_n \right] = \int_a^b y dx,$$

where  $\Delta x$  is the largest of the widths  $\Delta x_i$ .

The sum in the brackets above is sometimes written

$$\sum_{i=1}^n f(x_i)\Delta x_i.$$

$y_1\Delta x_1, y_2\Delta x_2$ , etc. are the areas of rectangles and it is easily seen that the sum of these areas, as the number of rectangles is allowed to increase without limit, will approach the area under the curve as a limiting value. This area has already been proved to represent the definite integral; hence, the limiting value of the sum of the rectangular areas as their number increases indefinitely is the definite integral of the function between the limits  $x = a$  and  $x = b$ .



In most of the older treatises on the calculus from Newton, the inventor, to the present, this summation has been given as the sum of the infinitesimals, which added together gave the definite integral. The sign  $\int$  which was a modified  $S$  representing *sum of*. Considerable difficulty has resulted because according to this idea the strips at the tops of the strips had to be neglected, and the triangles at the tops of the strips had to be neglected, and the impression retained was that the calculus was a method of approximation only. It is, therefore, important to emphasize the notion that it is the *limit of this sum* rather than the sum itself with which we are concerned, and this limit is a perfectly definite quantity no part of which is neglected. If this point is understood, no difficulty should be experienced with the definite integral as the representation of an area or a volume.

In the same way the summation theorem can be used in formulae for work, volume, etc.

$$\text{Work} = \lim_{\Delta s \rightarrow 0} [F_1 \Delta s_1 + F_2 \Delta s_2 + F_3 \Delta s_3 + \dots + F_n \Delta s_n]_a^b = \int_a^b F ds.$$

$$\text{Volume} = \lim_{\Delta x \rightarrow 0} [A_1 \Delta x_1 + A_2 \Delta x_2 + A_3 \Delta x_3 + \dots + A_n \Delta x_n] = \int_a^b A dx.$$

We now have integration also as a method of calculating the limit of a sum.

This method is to be used whenever a quantity under consideration is the limit of a sum of the type shown by

$$y_1 \Delta x_1 + y_2 \Delta x_2 + y_3 \Delta x_3 + \dots + y_n \Delta x_n = \sum f(x) \Delta x,$$

proceeding as follows:

Divide the required magnitude into parts such that it is evident that the result will be obtained by finding the limit of the sum of such parts. Now find expressions for the magnitude of the parts and integrate between the limits  $x = a$  and  $x = b$ . That is, find the limit of the sum as the number of parts is increased indefinitely.

Some authors represent the *fundamental theorem* in the form,

$$\lim_{\substack{n \rightarrow \infty \\ \Delta x \rightarrow 0}} \sum f(x) \Delta x = \int_a^b f(x) dx.$$

**EXAMPLE.**—Find the amount of coal which can be drawn from a conical pile having 100 feet as the diameter of the base and an angle of

repose of  $27^\circ$ , by a conveyor 2 m wide running flush with the ground across the center of the base of the pile.

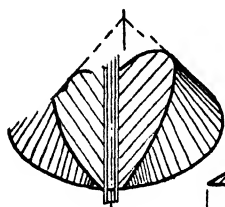

FIG. 610.

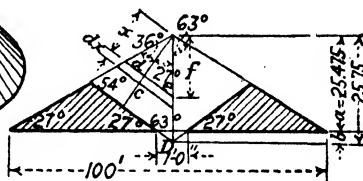

FIG. 611.

$$a = 50 \times \tan 27^\circ = 50 \times .5095 = 25.475.$$

$$b = .5 \times \tan 27^\circ = .5 \times .5095 = .255.$$

Height of cone =  $25.475 + .255 = 25.73$

Perpendicular distance  $c = 25.73 \times \cos 27^\circ$ .

$$= 25.73 \times .891 = 22.925.$$

If we take our  $x$  distances on  $c$  and cut our  $dx$  slices perpendicular to  $c$ , the sections will be parabolas as shown in Fig. 612.

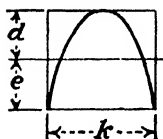

FIG. 612.

Thus,

$$d \text{ in terms of } x = \tan 36^\circ \times x.$$

$$= .7265x.$$

$$e \text{ in terms of } x = \tan 27^\circ \times x.$$

$$= .5095x.$$

$$\text{Height of parabolas} = d + e = 1.2360x.$$

$$f = \frac{x}{\cos 27^\circ} = \frac{x}{.891} = 1.122x.$$

$$k = 2f \times \tan 63^\circ = 2 \times 1.122x \times 1.963 = 4.405x.$$

Archimedes (250 B.C.) proved that a parabola inscribed in a rectangle has an area equal to exactly two-thirds of the rectangle (see Art. 560). We can, therefore, consider our  $dx$  slices as cutting rectangles 1.236 $x$  high and 4.405 $x$  wide and take two-thirds of these areas as the areas of the parabolas.

$$\begin{aligned} 2 \int_0^{22.925} \frac{2 \times 1.236x \times 4.405x}{3} dx &= 2 \int_0^{22.925} 3.6297x^2 dx. \\ &= 2 \left[ \frac{x-22.925}{3} \frac{3.6297x^3}{3} \right] \\ &= 2.42 \times (22.925)^3. \\ &= 29,156 \text{ cu. ft.} \end{aligned}$$

Deducting small triangular wedge volume at  $D$ , or

$$\frac{100 \times 1 \times .255}{2} = 12.75 \text{ cubic feet,}$$

$$29,156 - 13 = 29,143 \text{ cubic feet.}$$

$$\frac{29,143 \times 55 \text{ (weight of anthracite coal)}}{2000} = 801.43 \text{ tons.}$$

$$\text{Volume of full cone} = \frac{50 \times 50 \times 3.1416 \times 25.475}{3} = 66,693.$$

$$\text{Percentage drawn out} = \frac{29,143}{66,693} \times 100 = 43.7 \text{ per cent.}$$

**1037. Areas Bounded by Plane Curves. Rectangular Coordinates. Summation Method.**—We desire to find the area bounded by the curve,  $y = f(x)$ , the  $X$ -axis, and the two ordinates  $x = a$  and  $x = b$ .

The area is the limit of the sum of the rectangles  $y\Delta x$ , or

$$\begin{aligned} [639] \quad A &= \text{Limit}_{\Delta x \rightarrow 0} \sum_{a}^b y\Delta x = \int_a^b y dx. \\ &= \int_a^b f(x) dx, \end{aligned}$$

an answer that we would expect from Art. 1011 for the area under a curve.

Likewise, the area bounded by a curve, the  $Y$ -axis, and the abscissae  $y = c$  and  $y = d$  is

$$[640] \quad A = \text{Limit}_{\Delta x \rightarrow 0} \sum_c^d x\Delta y = \int_c^d x dy.$$

EXAMPLE.—Find the area bounded by the curve,  $x = 2 + y - y^2$ ,

and the  $Y$ -axis.

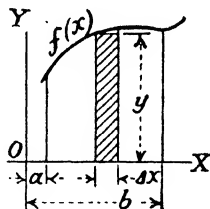

FIG. 613.

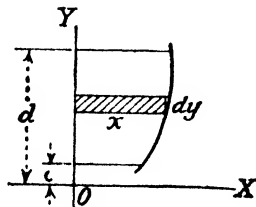

FIG. 614.

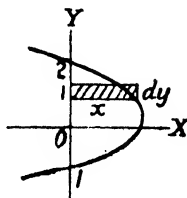

FIG. 615.

Where the curve crosses the  $Y$ -axis,  $x = 0$ , which substituted in the equation and solving for  $y$  gives

$$y = -1, y = 2.$$

$$A = \int_{-1}^2 x dy = \int_{-1}^2 (2 + y - y^2) dy.$$

$$\begin{aligned}
 &= \left[ 2y + \frac{y^2}{2} - \frac{y^3}{3} \right]_{-1}^1 \\
 &= (4 + 2 - \frac{2}{3}) - (-2 + \frac{1}{3} + \frac{1}{3}) \\
 &= 4\frac{1}{3}.
 \end{aligned}$$

EXAMPLE.—Find the area within the hypocycloid,  
 $x = a \sin^3 \theta$ ,  $y = a \cos^3 \theta$ .

From Fig. 616,

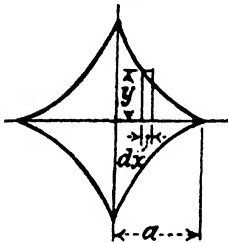

FIG. 616.

$$A = 4 \int_0^a y dx.$$

From  $x = a \sin^3 \theta$ ,

$$dx = 3a \sin^2 \theta \cdot \cos \theta d\theta.$$

Substituting these values of  $y$  and  $dx$  in the area formula,

$$A = 4 \int_0^{\frac{\pi}{2}} a \cos^3 \theta \cdot 3a \sin^2 \theta \cdot \cos \theta d\theta.$$

$$= 12a^2 \int_0^{\frac{\pi}{2}} \cos^4 \theta \cdot \sin^2 \theta d\theta.$$

Applying the reduction formula of Art. 1027 [627],

$$\int \cos^m x \cdot \sin^n x dx = \frac{\cos^{m-1} x \cdot \sin^{n+1} x}{m+n} + \frac{m-1}{m+n} \int \cos^{m-2} x \cdot \sin^n x dx$$

gives

$$\int \cos^4 \theta \cdot \sin^2 \theta d\theta = \frac{\cos^3 \theta \cdot \sin^3 \theta}{6} + \frac{3}{6} \int \cos^2 \theta \cdot \sin^2 \theta d\theta.$$

But  $2 \sin \theta \cdot \cos \theta = \sin 2\theta$ , whence

$$\cos^2 \theta \cdot \sin^2 \theta = \frac{1}{4} \sin^2 2\theta.$$

Therefore,

$$\frac{1}{2} \int \cos^2 \theta \cdot \sin^2 \theta d\theta = \frac{1}{2} \int \sin^2 2\theta d\theta.$$

This may be integrated by the method shown in the example of Art. 1021.

$$\frac{1}{2} \int \cos^2 \theta \cdot \sin^2 \theta d\theta = \frac{1}{16} (\theta - \frac{1}{4} \sin 4\theta) = \frac{4\theta - \sin 4\theta}{64}.$$

Therefore,

$$12a^2 \int \cos^4 \theta \cdot \sin^2 \theta d\theta = 12a^2 \left( \frac{\cos^3 \theta \cdot \sin^3 \theta}{6} + \frac{4\theta - \sin 4\theta}{64} \right).$$

Substituting the limits,

$$\text{Area} = 12a^2 \left( \frac{\pi}{32} \right) = \frac{3\pi a^2}{8}.$$

**1038. Summation Method. Polar Coordinates.**—If the polar equation of the curve is

$$\rho = f(\theta)$$

and the area is required between the curve and two radii vectors, then the required area is the limit of the sum of the circular sectors as shown in Fig. 617.

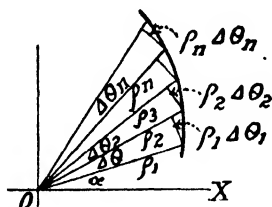

FIG. 617.

The sum of the areas of the sectors is

$$\frac{1}{2}\rho_1^2\Delta\theta_1 + \frac{1}{2}\rho_2^2\Delta\theta_2 + \dots + \frac{1}{2}\rho_n^2\Delta\theta_n = \sum_1^n \frac{1}{2}\rho_i^2\Delta\theta_i.$$

[641]  $\lim_{n \rightarrow \infty} \sum_1^n \frac{1}{2}\rho_i^2\Delta\theta_i = \int_\beta^\alpha \frac{1}{2}\rho^2 d\theta = \text{area required by fundamental theorem.}$

EXAMPLE.—Find the area of the cardioid whose equation is

$$\rho = a(1 + \cos \theta),$$

$\theta$  ranging from 0 to  $2\pi$ .

From  $\int_\beta^\alpha \frac{1}{2}\rho^2 d\theta$ ,

$$\begin{aligned} \text{Area} &= \int_0^{2\pi} \frac{1}{2} a^2 (1 + \cos \theta)^2 d\theta. \\ &= \int_0^{2\pi} \frac{a^2}{2} (1 + 2 \cos \theta + \cos^2 \theta) d\theta. \\ &= \frac{a^2}{2} \int_0^{2\pi} (1 + 2 \cos \theta + \cos^2 \theta) d\theta. \end{aligned}$$

But  $\cos^2 \theta = \frac{1}{2} \cos 2\theta + \frac{1}{2}$  (Art. 604) [298].

$$\begin{aligned} \text{Area} &= \frac{a^2}{2} \int_0^{2\pi} \left( 1 + 2 \cos \theta + \frac{1}{2} \cos 2\theta + \frac{1}{2} \right) d\theta. \\ &= \frac{a^2}{2} \int_0^{2\pi} \left( 1.5 + 2 \cos \theta + \frac{1}{2} \cos 2\theta \right) d\theta. \\ &= \frac{a^2}{2} \left[ 1.5\theta + 2 \sin \theta + \frac{1}{4} \sin 2\theta \right]_0^{2\pi}. \\ &= \frac{a^2}{2} (1.5 \times 2\pi) = \frac{3\pi a^2}{2}. \end{aligned}$$

1039. Length of Curve. Rectangular Coordinates.—From Art. 962 regarding measuring of curves and some of the theorems

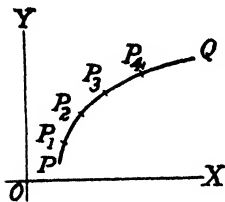

FIG. 618.

of geometry, the length of a curve is defined as the limit of the sum of the chords as the number of divisions of the curve is increased without limit and at the same time each chord approaches zero as a limit.

Let the curve be defined by an equation, as

$$y = f(x),$$

and the length of the arc  $PQ$  is to be determined. Points  $P(a, c)$  and  $Q(b, d)$  are given.

Take any number of points on  $PQ$  and draw chords joining these points. Then, arc  $PQ$  is the limit of the sum of the lengths of these chords as the number of chords is increased without limit.

Consider one of these chords, as  $P_1P_2$ , as a sample (Fig. 619). Then

$$\text{chord } P_1P_2 = \sqrt{(\Delta x_1)^2 + (\Delta y_1)^2}.$$

Dividing inside the radical by  $(\Delta x_1)^2$  and multiplying outside by  $\Delta x_1$ , then

$$P_1P_2 = \left[ 1 + \left( \frac{\Delta y_1}{\Delta x_1} \right)^2 \right]^{\frac{1}{2}} \Delta x_1.$$

From the theorem of the mean,

$$\frac{\Delta y_1}{\Delta x_1} = f'(x'),$$

where  $x'$  is the abscissa of the point  $P'$  at which the tangent to the curve is parallel to the chord  $P_1P_2$ . Then

$$\text{chord } P_1P_2 = [1 + f'(x')^2]^{\frac{1}{2}} \Delta x_1 = \text{length of first chord.}$$

In the same manner, the lengths of the chords  $P_2P_3, P_3P_4$ , etc. can be expressed.

The sum of these chords then is

$$[1 + f'(x')^2]^{\frac{1}{2}} \Delta x_1 + [1 + f'(x'')^2]^{\frac{1}{2}} \Delta x_2 + \dots + [1 + f'(x^n)^2]^{\frac{1}{2}} \Delta x_n \\ = \sum_{i=1}^n [1 + f'(x_i)^2]^{\frac{1}{2}} \Delta x_i.$$

$$\text{Limit}_{\Delta x \rightarrow 0} \sum_1^n [1 + f'(x_i)^2]^{\frac{1}{2}} \Delta x_i = \int_a^b [1 + f'(x)^2]^{\frac{1}{2}} dx \text{ by fundamental theorem.}$$

Or

$$[642] \quad S = \int_a^b \left[ 1 + \left( \frac{dy}{dx} \right)^2 \right]^{\frac{1}{2}} dx.$$

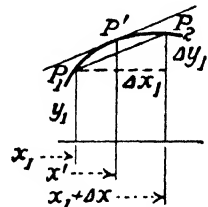

FIG. 619.

If  $y$  is used for the independent variable instead of  $x$ , then the formula becomes

[643] 
$$S = \int_c^d \left[ \left( \frac{dx}{dy} \right)^2 + 1 \right]^{\frac{1}{2}} dy,$$

where the  $y$  limits of integration are  $c$  and  $d$ .

EXAMPLE.—Find the length of the curve  $y = x^2$  from  $x = 3$  to  $x = 6$ .

If  $y = x^2$ ,  $\frac{dy}{dx} = 2x$ , and  $\left(\frac{dy}{dx}\right)^2 = 4x^2$ .

Then

$$S = \int_3^6 [1 + 4x^2]^{\frac{1}{2}} dx.$$

Let  $2x = \tan \varphi$ .

$$\therefore dx = \frac{1}{2} \sec^2 \varphi d\varphi.$$

The triangle in Fig. 620 shows the relations of the sides and

$$\sqrt{1 + 4x^2} = \sec \varphi.$$

Then

$$\begin{aligned} \int_3^6 [1 + 4x^2]^{\frac{1}{2}} dx &= \int_3^6 \sec \varphi \cdot \frac{1}{2} \sec^2 \varphi d\varphi = \frac{1}{2} \int_3^6 \sec^3 \varphi d\varphi. \\ &= \frac{1}{2} \int_3^6 \frac{d\varphi}{\cos^3 \varphi}. \end{aligned}$$

From [633],

$$\frac{1}{2} \int_3^6 \frac{d\varphi}{\cos^3 \varphi} = \frac{1}{2} \left[ \frac{\sin \varphi d\varphi}{2 \cos^2 \varphi} + \frac{1}{2} \int_3^6 \frac{d\varphi}{\cos \varphi} \right].$$

But from the figure,

$$\frac{\sin \varphi}{2 \cos^2 \varphi} = \frac{\frac{2x}{\sec \varphi}}{\frac{2}{\sec^2 \varphi}} = \frac{x \sqrt{1 + 4x^2}}{1 + 4x^2},$$

and from [610],

$$\int \frac{d\varphi}{\cos \varphi} = \log (\sec \varphi + \tan \varphi) = \log \sqrt{1 + 4x^2} + 2x.$$

Therefore,

$$\begin{aligned} \frac{1}{2} \left[ x\sqrt{1 + 4x^2} + \frac{1}{2} \log (\sqrt{1 + 4x^2} + 2x) \right]_3^6 &= \\ \frac{1}{2} [6\sqrt{1 + 144} - 3\sqrt{1 + 36}] &+ \\ + \frac{1}{2} [\log(\sqrt{1 + 144} + 12) - \log(\sqrt{1 + 36} + 6)] &= \\ = \frac{72.24 + 18.25}{2} + \frac{1}{2} [3.18 - 2.49] &= 27.34 \text{ units.} \end{aligned}$$



FIG. 620.

**1040. Length of Curve. Polar Coordinates.**—Let a straight line  $PN'$  be drawn perpendicular to  $OQ$  from  $P$  (Fig. 621).

$$(\text{chord } PQ)^2 = (PN')^2 + (N'Q)^2.$$

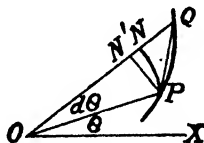

FIG. 621.

Rewriting this in equivalent form,

$$(\text{chord } PQ)^2 = \left( \frac{PN'}{\text{arc } PN} \right)^2 (\text{arc } PN)^2 + \left( \frac{N'Q}{NQ} \right)^2 (NQ)^2,$$

which equals, when substituting equivalents,

$$(\text{chord } PQ)^2 = \left( \frac{PN'}{\text{arc } PN} \right)^2 (r\Delta\theta)^2 + \left( \frac{N'Q}{NQ} \right)^2 (\Delta r)^2.$$

Rearranging again,

$$(\text{chord } PQ)^2 = \left[ \left( \frac{PN'}{\text{arc } PN} \right)^2 r^2 + \left( \frac{N'Q}{NQ} \right)^2 \left( \frac{\Delta r}{\Delta\theta} \right)^2 \right] (\Delta\theta)^2.$$

Now the length of the curve is the limit of the sum of the lengths of the chords as  $\Delta\theta$  approaches zero. The fractions  $\frac{PN'}{\text{arc } PN}$  and  $\frac{N'Q}{NQ}$  both approach 1 as  $\Delta\theta$  approaches zero and arcs  $PQ$  approach chords  $PQ$ .

Hence, the length of arc,

$$[644] \quad S = \int \left[ r^2 + \left( \frac{dr}{d\theta} \right)^2 \right]^{\frac{1}{2}} d\theta.$$

For definite integrals, or length of arc between two limiting angles, then

$$[645] \quad S = \int_{\alpha}^{\beta} \left[ r^2 + \left( \frac{dr}{d\theta} \right)^2 \right]^{\frac{1}{2}} d\theta.$$

The length of arc can also be expressed as

$$[646] \quad S = \int_{\gamma}^{\delta} \left[ 1 + r^2 \left( \frac{d\theta}{dr} \right)^2 \right]^{\frac{1}{2}} dr.$$

**EXAMPLE.**—Find the whole length of the cardioid,

$$r = 2a(1 - \cos \theta).$$

Differentiating the expression,

$$\frac{dr}{d\theta} = 2a \sin \theta.$$



Substituting in above expression,

$$S = \int_0^\pi 2a[(1 - \cos \theta)^2 + \sin^2 \theta]^{\frac{1}{2}} d\theta.$$

$$= 2 \int_0^\pi 4a \sin \frac{\theta}{2} d\theta = 16a \left[ -\cos \frac{\theta}{2} \right]_0^\pi = 16a.$$

**1041. Surfaces of Revolution.**—When a curve,  $y = f(x)$ , is revolved about the  $X$ -axis, a curved surface is generated. Let the area of this surface be denoted by  $S$ .

Consider an infinitesimal arc  $ds$  as being rotated and generating a narrow band running around the surface. Its length would be  $2\pi y$ , its width  $ds$ , and its area  $2\pi y \cdot ds$ , but from Art. 1039 for the length of the curve, we have

$$PP' = ds = \sqrt{1 + \left(\frac{dy}{dx}\right)^2} dx,$$

which substituted in the above formula gives

$$\text{Surface} = \int 2\pi y \left[ 1 + \left(\frac{dy}{dx}\right)^2 \right]^{\frac{1}{2}} dx.$$

Or

[647] Area of surface of revolution =  $2\pi \int_a^b y \left[ 1 + \left(\frac{dy}{dx}\right)^2 \right]^{\frac{1}{2}} dx$ ,

or since

$$ds = \sqrt{(dx)^2 + (dy)^2} = \left[ 1 + \left(\frac{dy}{dx}\right)^2 \right]^{\frac{1}{2}} dx,$$

then

[648] Area of surface =  $\int_a^b 2\pi y ds = 2\pi \int_a^b y ds$ .

EXAMPLE.—Find the area generated by revolving the parabola,

$$y^2 = 4x,$$

about the  $X$ -axis and between  $x = 0$  and  $x = 8$ .

$$y^2 = 4x.$$

$$y = 2x^{\frac{1}{2}}.$$

$$\frac{dy}{dx} = x^{-\frac{1}{2}} = \frac{1}{\sqrt{x}}.$$

$$\therefore \text{Surface} = \int_0^8 4\pi x^{\frac{1}{2}} \left( 1 + \frac{1}{x} \right)^{\frac{1}{2}} dx = 4\pi \int_0^8 (x + 1)^{\frac{1}{2}} dx.$$

$$= \frac{8}{3} \pi (x + 1)^{\frac{3}{2}} \Big|_0^8 = \frac{216}{3} \pi.$$

**1042. Volumes of Solids of Revolution.**—Let  $V$  denote the volume of the solid generated by the rotation of the curve  $CD$  about the axis  $AB$  or the  $X$ -axis.

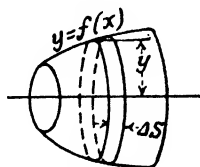

FIG. 622.

Let the equation of the curve  $CD$  be

$$y = f(x).$$

Divide the area  $ACDB$  into rectangular strips as shown in Fig. 623.

Each rectangle, when rotated, generates a cylinder.

The required volume is equal to the limit of the sum of the volumes of these cylinders as their number is made to increase without limit.

If the length of these cylindrical slices is denoted by  $\Delta x_1, \Delta x_2, \Delta x_3,$  etc., and if the corresponding radii are denoted by  $y_1, y_2, y_3,$  etc., then the volume of the first cylinder considered is  $\pi y_1^2 \Delta x_1$ .

The sum of the volumes of all such cylinders is then

$$\pi y_1^2 \Delta x_1 + \pi y_2^2 \Delta x_2 + \pi y_3^2 \Delta x_3 + \dots + \pi y_n^2 \Delta x_n = \sum_1^n \pi y_i^2 \Delta x_i.$$

Applying the fundamental theorem,

$$\lim_{n \rightarrow \infty} \sum_1^n \pi y_i^2 \Delta x_i = \int_a^b \pi y^2 dx.$$

Hence,

$$[649] \quad \text{Volume} = V = \pi \int_a^b y^2 dx.$$

EXAMPLE.—Find the volume generated by rotating the ellipse,

$$\frac{x^2}{a^2} + \frac{y^2}{b^2} = 1,$$

about the  $X$ -axis.

Transposing,

$$y^2 = \frac{b^2}{a^2}(a^2 - x^2).$$

Since it is more convenient to consider the rotation of only the right half of the ellipse, that is, the rotation of  $AB$  about  $OB$ , and to multiply the result so obtained by 2, then

$$\begin{aligned} \frac{V}{2} &= \pi \int_0^a y^2 dx. \\ &= \pi \int_0^a \frac{b^2}{a^2}(a^2 - x^2) dx = \frac{2\pi ab^2}{3}. \\ \therefore V &= \frac{4\pi ab^2}{3}. \end{aligned}$$

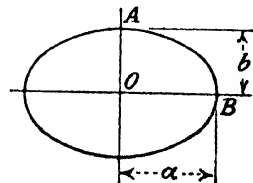

FIG. 624.

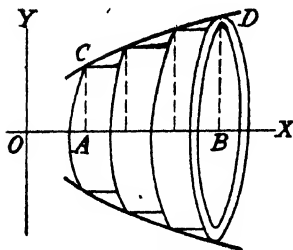

FIG. 623.

**1043. Fluid Pressures against Vertical Walls.**—Let  $ABCD$  represent part of the area of the wall of a reservoir, and the total fluid pressure against the wall is required.

If we divide  $AC$  into  $n$  parts all of typical area  $y \cdot \Delta x$ , since the pressure per square foot is equal to the depth times the weight  $W$  of 1 cubic foot of the fluid, then the pressure on the rectangular strip is

$$Wxy \cdot \Delta x,$$

and the sum of all the pressures on the  $n$  rectangles is approximately

$$\sum Wxy \cdot \Delta x.$$

The pressure on  $ABCD$  is the *limit* of this sum. Hence, by the fundamental theorem,

$$\lim_{n \rightarrow \infty} \sum Wxy \cdot \Delta x = \int Wxy dx = W \int xy dx.$$

The pressure on a vertical submerged surface bounded by a curve, the  $X$ -axis, and the horizontal lines,  $x = a$  and  $x = b$ , is

[650] 
$$\text{Fluid pressure} = W \int_a^b yxdx.$$

**EXAMPLE.**—Find the pressure on a gate which closes a circular main whose diameter is 6 feet, when the main is half full of water.

From the equation of the circle,

$$x^2 + y^2 = 9,$$

we have

$$y = \sqrt{9 - x^2}.$$

For water,  $W = 62$ .

The limits of integration are  $x = 0$  and  $x = 3$ . Then

$$\begin{aligned} \text{Fluid pressure} &= 62 \int_0^3 \sqrt{9 - x^2} dx. \\ &= -[9^2(9 - x^2)]_0^3 = 558. \end{aligned}$$

Total pressure =  $2 \times 558 = 1116$  pounds.

Note that  $y$  must be a function of  $x$ .

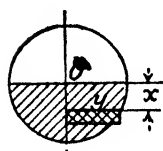

FIG. 626.

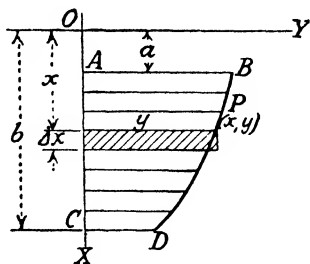

FIG. 625.

**1044. Work of Lifting Fluids.**—The work done in lifting equals the weight multiplied by the vertical height through which it is lifted. In emptying a cistern or a reservoir, as the level of the

water is lowered, the height increases and we have a variable height to consider.

Consider a reservoir as shown in Fig. 627. We desire to know the amount of work done in emptying from depth  $a$  to depth  $b$  and lifting to height  $O$ .

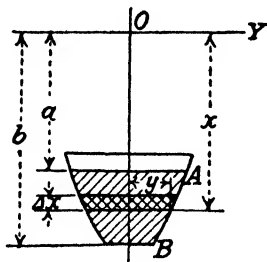

FIG. 627.

Divide  $AB$  as usual into  $n$  cylinders of thickness  $\Delta x$ . The volume of each cylinder is

$$\pi y^2 \cdot \Delta x,$$

and its weight is

$$W\pi y^2 \cdot \Delta x.$$

The work done in raising this cylinder of fluid is

$$W\pi y^2 \cdot \Delta x \times x.$$

The work done in lifting all of the cylinders is

$$\Sigma W\pi y^2 x \cdot \Delta x,$$

and

$$\text{Limit}_{n \rightarrow \infty} \Sigma W\pi y^2 x \cdot \Delta x = \int W\pi y^2 x \cdot \Delta x.$$

Therefore, between the limits  $x = a$  and  $x = b$ .

$$[651] \quad \text{Work} = \int_a^b W\pi y^2 x dx = W\pi \int_a^b y^2 x dx.$$

**EXAMPLE.**—Find the work done in pumping out the water from a hemispherical reservoir 10 feet deep and raising the water to a height of 10 feet above the reservoir.

Equation of a circle of radius 10 and center at  $O$  is

$$x^2 + y^2 = 100.$$

Equation of a circle of same radius but with center at  $O_1$  is

$$(x - 10)^2 + y^2 = 100.$$

Developing,

$$y^2 = 20x - x^2.$$

Therefore,

$$\begin{aligned} \text{Work} &= 62\pi \int_{10}^{20} (20x - x^2)xdx. \\ &= 194.78 \int_{10}^{20} (20x^2 - x^3)dx. \\ &= 194.78 \left[ \frac{20x^3}{3} - \frac{x^4}{4} \right]_{10}^{20}. \\ &= 1,785,548 \text{ foot-pounds.} \end{aligned}$$

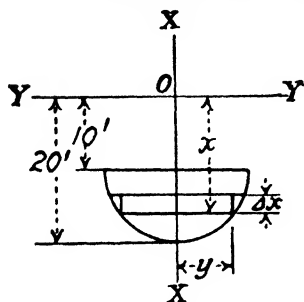

FIG. 628.

## CHAPTER LVI

### EXAMPLES OF INTEGRATION

**1045. Example of Integration.**—A quantity  $y$  increases with  $x$  at a rate constantly equal to  $.06y$ . If  $y = 80$  when  $x = 0$ , find the equation for the function.

First, note that the quantity varies at a rate which is a percentage of the function itself and, therefore, follows the exponential law or the compound interest law (Art. 958).

From the statement of the problem,

$$\frac{dy}{dx} = .06y.$$

This can be integrated in this form but if we divide both sides by  $y$ , then

$$\frac{1}{y} \cdot \frac{dy}{dx} = .06.$$

The left member is now the derivative, with respect to  $x$ , of  $\log y$ . Then

$$\log y = .06x + C.$$

But  $y = 80$  when  $x = 0$ . Therefore,

$$\log y = \log 80 = 0 + C.$$

$$\therefore C = \log 80.$$

Then

$$\log y = .06x + \log 80,$$

or

$$\log y - \log 80 = .06x,$$

whence

$$\log \frac{y}{80} = .06x.$$

This means that  $.06x$  is the exponent to which the base  $e$  must be raised to equal the fraction  $\frac{y}{80}$ .

Therefore,

$$\frac{y}{80} = e^{.06x} \text{ or } y = 80e^{.06x}.$$

**1046. Tension in Belt and Pulley Drive.**—Consider a small element  $\Delta s$  of the belt at the top of the pulley subtending an angle  $\Delta\theta$  of the arc  $\theta$  of contact in radians.

Consider the small element  $\Delta s$  as a free body and the forces acting on it. We will, therefore, use a law of mechanics and since the body is in equilibrium, we will equate the horizontal and vertical forces.

Let  $T$  = tension on one end of  $\Delta s$ .

$T + \Delta T$  = tension on other end of  $\Delta s$ .

$P$  = the normal pressure.

$\mu$  = the coefficient of friction.

The difference between the horizontal components of  $T$  and  $T + \Delta T$  is equal to the friction due to  $P$  or to  $\mu P$ . Then

$$(T + \Delta T)\cos \frac{\Delta\theta}{2} - T \cos \frac{\Delta\theta}{2} = \mu P.$$

Reducing,

$$\Delta T \cos \frac{\Delta\theta}{2} = \mu P.$$

Resolving vertically,

$$P = (T + \Delta T) \sin \frac{\Delta\theta}{2} + T \sin \frac{\Delta\theta}{2}.$$

$$= 2T \sin \frac{\Delta\theta}{2} + \Delta T \sin \frac{\Delta\theta}{2}.$$

Combining,

$$\Delta T \cos \frac{\Delta\theta}{2} = \mu(2T + \Delta T) \sin \frac{\Delta\theta}{2}, \text{ or}$$

$$\Delta T = \frac{\mu(2T + \Delta T)}{\cos \frac{\Delta\theta}{2}} \sin \frac{\Delta\theta}{2}, \text{ or}$$

$$2\frac{\Delta T}{\Delta\theta} = \frac{\mu(2T + \Delta T)}{\cos \frac{\Delta\theta}{2}} \cdot \frac{\sin \frac{\Delta\theta}{2}}{\frac{\Delta\theta}{2}}.$$

Now as  $\Delta\theta$  approaches 0,  $\cos \frac{\Delta\theta}{2}$  approaches 1, and  $\frac{\sin \frac{\Delta\theta}{2}}{\frac{\Delta\theta}{2}}$

approaches 1, and  $\frac{\Delta T}{\Delta\theta}$  approaches  $\frac{dT}{d\theta}$ .

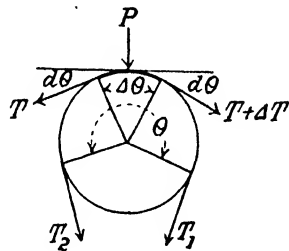

FIG. 629.

Hence, taking the limit of both sides,

$$2 \frac{dT}{d\theta} = \mu \cdot 2T, \text{ or } \frac{dT}{d\theta} = \mu T.$$

$$dT = \mu T d\theta.$$

Grouping like variables together for purposes of integration,

$$\frac{dT}{T} = \mu d\theta.$$

Confining the variables to their proper limits and integrating,

$$\int_{T_1}^{T_2} \frac{dT}{T} = \mu \int_0^\theta d\theta,$$

or

$$\log_e T_1 - \log_e T_2 = \mu\theta,$$

or

$$[652] \quad \log_e \frac{T_1}{T_2} = \mu\theta \text{ (in the log form),}$$

or

$$[653] \quad \frac{T_1}{T_2} = e^{\mu\theta} \text{ (in the exponential form).}$$

In the case of a tandem belt conveyer drive where *A* and *B* (Fig. 630) are geared together as the drive, then

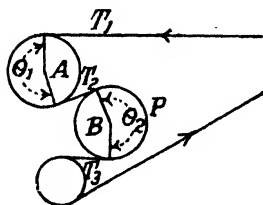

FIG. 630.

$$\frac{T_1}{T_2} = e^{\mu\theta_1} \text{ and } \frac{T_2}{T_3} = e^{\mu\theta_2}.$$

Combining,

$$\frac{T_1}{T_3 e^{\mu\theta_2}} = e^{\mu\theta_1},$$

or the ratio of the tensions in the tight to the slack side is

$$[654] \quad \frac{T_1}{T_3} = e^{\mu(\theta_1 + \theta_2)}.$$

If the angle of contact is the same for both pulleys, then

$$[655] \quad \frac{T_1}{T_3} = e^{\mu 2\theta}.$$

If three drive pulleys were used, then

$$\frac{\text{Tension in tight belt}}{\text{Tension in slack belt}} = e^{(\theta_1 + \theta_2 + \theta_3)\mu}.$$

It is assumed, of course, that the speed ratios compensate for the stretch in the belt or that the transmitting force of the driving pulleys is equalized.



**1047. Law of Cooling.**—Newton established the law of cooling which states that the temperature of a heated body surrounded by a medium, as air, of constant temperature decreases at a rate proportional to the difference in temperature of the body and the medium.

If  $\theta$  denotes this difference in degrees, then

$$\text{Rate of change of temperature} = \frac{d\theta}{dt},$$

and the given relation is

$$-\frac{d\theta}{dt} = k\theta,$$

where  $k$  is a constant depending upon the units used.

Putting in differential form,

$$dt = -\frac{1}{k} \cdot \frac{d\theta}{\theta}.$$

We now come to the object of this example. It is possible to integrate each variable between the proper limits, as  $t$  between  $t_1$  and  $t_2$  and  $\theta$  between  $\theta_1$  and  $\theta_2$ , or

$$\begin{aligned} \int_{t_1}^{t_2} dt &= -\frac{1}{k} \int_{\theta_1}^{\theta_2} \frac{d\theta}{\theta} = -\frac{1}{k} \log \theta \Big]_{\theta_1}^{\theta_2} \\ &= \frac{1}{k} \log \frac{\theta_1}{\theta_2}. \end{aligned}$$

[656] 
$$t_2 - t_1 = \frac{1}{k} \log \frac{\theta_1}{\theta_2}.$$

It will readily be seen that the greater the difference of temperature, the more rapid is the rate of cooling, and if you wish to cool your coffee in the shortest time during a hurried breakfast, let it stand as long as possible before you add the cream.

**1048. Work Done by an Expanding Gas.**—The expansion of gases isothermally, or with constant temperature, is represented by the hyperbolic curve,  $y = \frac{1}{x}$ . From the differential of  $\log x$  (Art. 952) [542], the differential curve was

$$y' = \frac{dy}{dx} = \frac{1}{x}.$$

Therefore, the work done by the expanding gas is represented by the log curve.

**1049. Deriving the Equations of Motion of a Projectile (by Integration).**—If we ignore the air resistance, there is no hori-

zontal acceleration and the vertical acceleration due to gravity is  $-32$  feet per second per second. That is,

$$\frac{d^2x}{dt^2} = 0. \quad \frac{d^2y}{dt^2} = -32. \quad (1)$$

Integrating both of these twice gives the desired equations. The constants of integration are determined by the way in which the projectile is fired.

EXAMPLE.—Find the equations of motion of a projectile fired with a speed of 2000 feet per second at an inclination of  $30^\circ$ .

Integrating equations (1) above,

$$\frac{dx}{dt} = C. \quad \frac{dy}{dt} = -32t + C_1. \quad (2)$$

Integrating again,

$$[657] \quad x = Ct + k. \quad y = -16t^2 + C_1t + k_1. \quad (3)$$

If we have chosen our axes so as to pass through the firing point, then  $x = 0$  and  $y = 0$ , when  $t = 0$ . Hence,  $k = 0$  and  $k_1 = 0$ .

To determine  $C$  and  $C_1$  from (2) when  $t = 0$ .

$$\frac{dx}{dt} = C \text{ and } \frac{dy}{dt} = C_1.$$

The component speeds, or

$$V_x = \frac{dx}{dt} = 2000 \cos 30^\circ = 1732.$$

$$V_y = \frac{dy}{dt} = 2000 \sin 30^\circ = 1000.$$

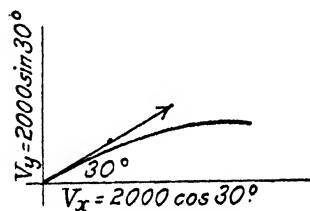

FIG. 631.

Substituting these values of  $C$  and  $C_1$  in (3),

$$x = 1732t. \quad y = 1000t - 16t^2.$$

**1050. Distance Traveled.**—Knowing the speed  $V$  of a moving object at every instant, we can find by integration the distance  $S$  traveled during any interval of time.

$$S = \int V dt.$$

If

$$x = t^2 \text{ and } y = \frac{1}{3}t^3 - t,$$

then

$$V_x = 2t \text{ and } V_y = t^2 - 1.$$

From

$$V = \sqrt{(V_x)^2 + (V_y)^2},$$

$$V = \sqrt{(2t)^2 + (t^2 - 1)^2} = \sqrt{t^4 + 2t^2 + 1} = t^2 + 1.$$

Hence, the distance traveled is

$$[658] \quad S = \int V dt = \int (t^2 + 1) dt = \frac{1}{3}t^3 + t.$$

The constant of integration is zero since  $S = 0$  when  $t = 0$ .

**1051. Beams.**—The *shearing force* at any section of a beam is the algebraic sum of all the transverse forces acting on one side of the section taken. When the sum or resultant forces act upward on the left of the section, the force is considered positive, and if downward, it is considered negative.

Consider a beam supporting a uniform load of  $w$  pounds per foot and four concentrated loads  $W_1$ ,  $W_2$ ,  $W_3$ , and  $W_4$ , and let  $R_1$  and  $R_2$  represent the left and right reactions.

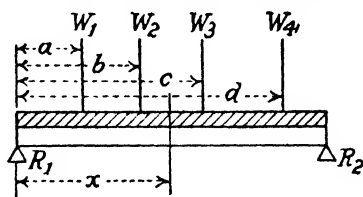

FIG. 632.

The shear, then, at any section, say between the second and third concentrated loads, is

$$S = R_1 - W_1 - W_2 - wx.$$

The *bending moment* at any section is the algebraic sum of the moments of all the forces acting on one side of the section taken about the center of gravity of the section as an axis. When the resultant moment is clockwise, it is positive, and when counterclockwise, it is negative.

Referring to Fig. 632, then, the bending moment is

$$[659] \quad M = R_1x - W_1(x - a) - W_2(x - b) - \frac{wx^2}{2}.$$

Let us now differentiate this equation of the bending moment.

$$\frac{dM}{dx} = R_1 - W_1 - W_2 - wx.$$

Compare this equation with the equation for the shear and note that they are the same. The moment and shear curves always have the relation of primary and derived curves.

If we draw the moment curve and differentiate it graphically, we obtain the shear curve. If we are given the shear curve, which is easily found, we can obtain the moment curve by graphical integration.

Suppose that we are given a beam loaded as shown in Fig. 633.

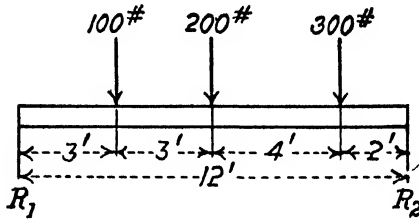

FIG. 633.

$$\begin{aligned} \text{Reaction } R_1 &= \frac{100 \times 9 + 200 \times 6 + 300 \times 2}{12} \\ &= \frac{900 + 1200 + 600}{12} = 225. \end{aligned}$$

$$\begin{aligned} \text{Reaction } R_2 &= \frac{100 \times 3 + 200 \times 6 + 300 \times 10}{12} \\ &= \frac{300 + 1200 + 3000}{12} = 375. \end{aligned}$$

It will be noted that the slope of the curve for the first three units is the same. Therefore, if the slope for one is found, the same slope can be continued for the three units.

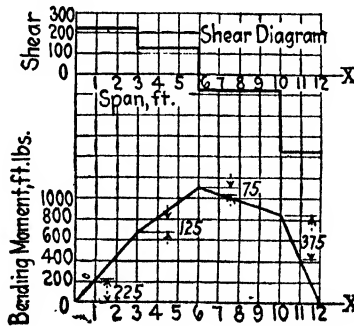

FIG. 634.

Since the bending moments at the ends of the beam are zero, then our constant of integration is zero and we start the moment curve at zero.

1052.

EXAMPLE.—Consider a beam loaded as shown in Fig. 635.

$$R_1 = \frac{200 \times 12 + 100 \times 7 + 250 \times 4 + 200 \times 2}{9} = \frac{2400 + 700 + 1000 + 400}{9} = 500.$$

$$R_2 = \frac{100 \times 5 + 250 \times 8 + 200 \times 10 - 500 \times 3}{12} = \frac{500 + 2000 + 2000 - 1500}{12} = 250.$$

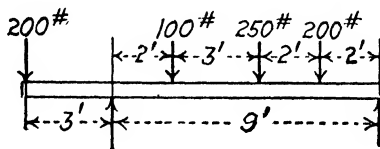

FIG. 635.

Note from the diagram that there are two places where maximum bending occurs, one a positive ( $x = 3$ ) and the other a negative ( $x = 8$ ).

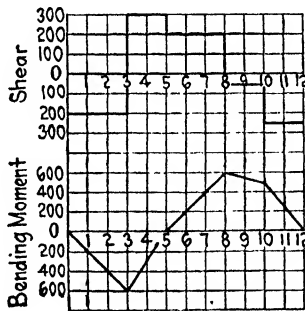

FIG. 636.

1053. Uniformly Loaded Beams.—Consider the case of a uniformly loaded beam  $l$  feet in length and loaded  $w$  pounds per foot.

Total load of the beam =  $wl$ .

Load on each reaction =  $\frac{wl}{2}$ .

Shear at  $x$  distance from end =  $\frac{wl}{2} - wx$ .

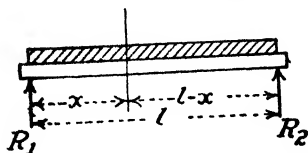

FIG. 637.

$$\text{Bending moment} = \frac{wlx}{2} - \frac{wx^2}{2}.$$

Let us examine the nature of this moment curve, calling the bending moment or value of the function,  $Y$ . Then

$$Y = \frac{wlx}{2} - \frac{wx^2}{2},$$

or

$$\frac{wx^2}{2} - \frac{wlx}{2} + Y = 0.$$

Comparing with the general form of equations of the second degree,

$$A = \frac{w}{2}, D = -\frac{wl}{2}, E = 1, \text{ and } B^2 - 4AC = 0,$$

and the equation represents a translated parabola.

Let us complete the square of the second-degree term after modifying the form.

Dividing by  $\frac{w}{2}$ ,

$$x^2 - lx = -\frac{2Y}{w}.$$

Completing the square,

$$x^2 - lx + \frac{l^2}{4} = \frac{l^2}{4} - \frac{2Y}{w}.$$

[660]  $\left(x - \frac{l}{2}\right)^2 = \frac{-8Y + l^2w}{4w} = -\frac{2}{w} \left(Y - \frac{l^2w}{8}\right).$

The negative sign indicates that the parabola is inverted with vertex pointing upward (see Fig. 638).

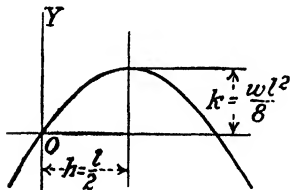

FIG. 638.

Also, the origin is  $\frac{l}{2}$  units to the left of the axis of the parabola and  $\frac{l^2w}{8}$  units below the vertex of the parabola.

It will also be observed that  $k$  or  $\frac{l^2w}{8}$  is the maximum bending moment of the beam, a quantity which will be found in any book on the strength of materials.

As an illustrative example, the diagrams of Fig. 639 represent the case of a beam 12 feet long uniformly loaded, the load being 200 pounds per foot.

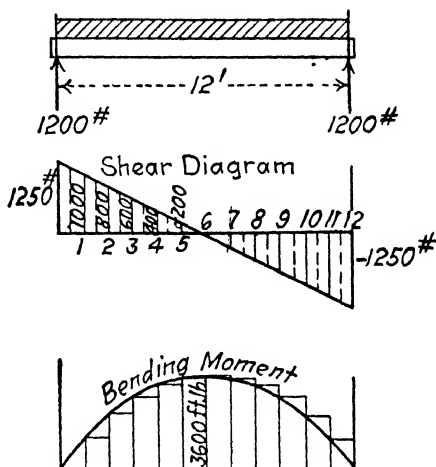

FIG. 639.

Advantage may be taken of this parabolic law to make a chart from which the maximum bending moments for any uniform load and span can be found.

From the equation,

$$x^2 = -\frac{2}{w} Y,$$

which is the equation of the bending moment when the origin is at the vertex, and selecting suitable horizontal and vertical scales, the bending moment will be a multiple of the load  $w$  per foot.

For instance, for a beam of 16-foot span, loaded 200 pounds per foot, the maximum ordinate is  $32w$ , or  $32 \times 200 = 6400$  pounds.

For a beam of 20-foot span loaded 300 pounds per foot, the maximum bending moment equals  $50w$ , or  $50 \times 300 = 15,000$  pounds.

For any span, as 15 feet, with a divider set to 15 units, find a place where the parabola is 15 units wide and the ordinate at

this point multiplied by the loading per foot gives the maximum bending moment.

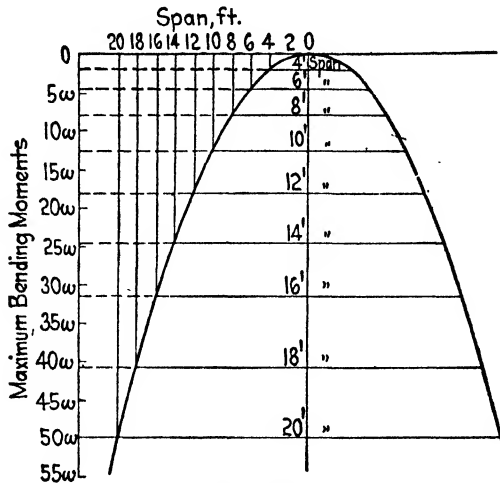

FIG. 640.

If the bending moment at a certain point of the beam is desired, measure the ordinate in terms of the vertical units and multiply by the load per foot.

The shear diagram can also be readily drawn by laying off the reactions as shown in Fig. 641 and drawing the diagonal line.

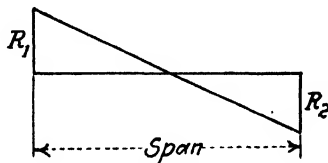

FIG. 641.

The graphical method of finding the shear and bending moment of beams is the proper method to use, especially if the beam is loaded by a combination of concentrated and uniform loads.

**1054. Resisting Moments of Beams.**—The bending moments of the loads on a beam must be balanced by the resisting moment of the section of the beam.

Represent the beam section as shown. Consider that there is a line through the beam called the *neutral axis* where the



sum of the moments of areas of strips (that is, their areas times their distances from the neutral axis) on the tension side of the beam will balance the area of strips times their distances from the neutral axis on the compression side of the beam.

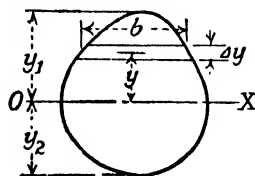

FIG. 642.

Moreover, consider that the original radius of curvature of the beam is exceedingly great compared with the beam section.

Let  $OX$  be the neutral axis and let  $f$  be the stress at units distance from  $OX$ . Then the stress at  $y$  distance is  $fy$ .

The resisting force of the strip is

$$\text{Stress} \times \text{Area of strip} = b\Delta y \times fy.$$

The moment of the strip is

$$b\Delta yfy \times y = fb\Delta y \cdot y^2.$$

Since the sums of the tensile and compression moments are equal, the summation of the strips becomes

$$\sum_{-y_2}^{y_1} fb\Delta y \cdot y^2.$$

Passing to the limit, this equals

$$f \int by^2 dy,$$

or

$$\text{Moment of resistance} = f \int (\text{Area} \times [\text{Distance}]^2).$$

Now  $\int \text{Area} \times (\text{Distance})^2$ , which is called the second moment, happens to take the same form as the integral for the *moment of inertia*. Just why we should consider that a stationary beam should have a moment of inertia is beyond the author, even if the same form of equation results. This was more or less of a mystery to me in my college work, and it is unfortunate that such a connection was made to moment of inertia years ago. A better name is *moment of section*. However, since all reference books write it thus, we can only protest and then follow the precedent.

Then,

[661]

$$\text{Resisting moment} = fI.$$

If  $M$  = the bending moment, then since the bending moment equals the resisting moment,

$$M = fI.$$

If  $f_1$  = maximum tensile stress =  $fy_1$  and

$f_2$  = maximum compressive stress =  $fy_2$ ,

then

$$f = \frac{f_1}{y_1} = \frac{f_2}{y_2} = \frac{M}{I},$$

or

$$[662] \quad \frac{M}{I} = \frac{f}{C},$$

where  $C$  is the distance of the fiber from the neutral axis carrying the greatest fiber stress and may be either  $y_1$  or  $y_2$  whichever is greater.

**1055. Energy.**—When a body is capable of doing work against forces applied to it, it possesses energy.

A stretched spring can do work against a force, provided the force permits the spring to contract. A moving body can do work against a force which acts to stop it. Both the spring and the body possess energy.

The energy of position is called *potential energy* and the energy of motion is called *kinetic energy*. The spring cited as an example above, then, has potential energy and the moving body has kinetic energy.

The amount of energy possessed by a body at any instant is the amount of work that it can do against a force while changing from its condition at that instant to a state or condition assumed to be standard. The unit of energy, then, is the same as the unit of work.

The amount of kinetic energy which a body possesses at any instant is the work which it can do while the velocity changes from its value at the instant to the value taken as standard.

Zero velocity is usually taken as the standard, and the kinetic energy, then, is the work that the body can do in giving up all of its velocity.

A force of  $p$  pounds acts on a mass of  $m$  or  $\frac{W}{g}$  pounds which is moving with a velocity of  $V$  feet per second in the direction of

the force. During the time interval  $\Delta t$  the displacement is  $\Delta s = V\Delta t$ . This follows since

$$\frac{\Delta s}{\Delta t} = V.$$

The work done by the force of  $P$  pounds for the interval  $\Delta t$  is

$$\Delta U = P\Delta s = PV\Delta t. \quad (1)$$

The force  $P$  equals the product of the mass times the acceleration, and the acceleration for the interval  $\Delta t$  is

$$\frac{\Delta V}{\Delta t}, \text{ and therefore,}$$

$$P = \frac{W}{g} \cdot \frac{\Delta V}{\Delta t}. \quad (2)$$

Substitute (2) in (1). Then

$$\Delta U = \frac{W}{g} \cdot \frac{\Delta V}{\Delta t} \cdot V\Delta t, \text{ or } \frac{\Delta U}{\Delta V} = \frac{WV}{g}.$$

Passing to the limit,

$$\frac{dU}{dV} = \frac{WV}{g}.$$

Therefore,

$$[663] \quad U = \frac{WV^2}{2g}.$$

If the body starts from an initial velocity of  $V_0$ , the limits of integration are  $V$  and  $V_0$ , but if it starts from rest, the limits are  $V$  and 0.

The formula, therefore, gives the entire work done in increasing the velocity of the body from zero to  $V$ .

Since this work imparts velocity to the body, the velocity in turn gives an equal amount of kinetic energy which the body will impart by being brought to rest. Therefore,

$$\text{Kinetic energy (in foot-pounds)} = \frac{(\text{Weight})(\text{Velocity})^2}{2 \times 32.174} = \frac{1}{2}(\text{Mass}) \times (\text{Velocity})^2.$$

Potential energy, or the energy of position, can be illustrated by a weight lifted a given height above the earth.

It is capable of doing work equal to the product of its weight by the distance the body has been raised.

If no energy is lost due to friction or by change into heat, the sum of the potential energy and the kinetic energy of a body or of a system of bodies remains constant.

**1056. Momentum.**—The quantity of motion of a moving body is called its momentum. If the mass and the velocity of a moving body are constant, the momentum is the product of the two, or

$$M = mV.$$

If we differentiate momentum with respect to the time, then

$$\frac{d(mV)}{dt} = m \frac{dV}{dt} = \text{rate of change of momentum.}$$

But

$$m \frac{dV}{dt} = f = \text{force.}$$

Force, then, can also be called the rate of change of momentum as well as mass times acceleration.

Momentum is a vector quantity and can be resolved into components or combined into resultants.

The unit of momentum is the momentum of unit mass moving with unit velocity.

Now,

$$m = \frac{W}{g} \text{ (where } W \text{ is in pounds, } g \text{ is in feet per second per second).}$$

Then

$$m = \frac{\text{Pounds}}{\frac{\text{Feet}}{\text{Seconds}^2}} = \frac{\text{Pounds} \times \text{Seconds}^2}{\text{Feet}}$$

and

$$[664] \quad mV = M = \frac{\text{Pounds} \times \text{Seconds}^2}{\text{Feet}} \times \frac{\text{Feet}}{\text{Seconds}} = \text{Pounds} \times \text{Seconds.}$$

**1057. Relations of Work, Impulse, Impact, and Momentum.**—The effect of a force may be given in terms of the product of the force and distance, which is called *work*, or the product of the force and time, which is called *impulse*. The product of the mass times the acceleration, which is called the *rate of change of momentum*, is the force.

Impulse, like force, is a vector quantity. If a force  $F$  is constant both in magnitude and direction during a time  $t$ , the impulse

$Q$  is  $Ft$ . If  $F$  varies in magnitude, the impulse for the time  $\Delta t$  is  $F\Delta t$ , or

$$\Delta Q = F\Delta t. \quad \text{Hence, } \frac{\Delta Q}{\Delta t} = F \text{ and } \frac{dQ}{dt} = F$$

Then for any time  $t$ ,

$$Q = \int_0^t F dt.$$

$F$  must be expressed in terms of  $t$  in order to perform the integration.

The unit of impulse is the impulse of a unit of force acting for a unit of time and is called the pound-second.

If a force  $F$  acts upon a mass  $M$  to produce an acceleration  $a$ , then

$$F = Ma.$$

If  $F$  is constant, then  $a$  is also constant, and

$$a = \frac{V - V_0}{t},$$

or

$$[665] \quad F = M \times \frac{V - V_0}{t} \text{ or } Ft = MV - MV_0.$$

If  $F$  varies in magnitude,

$$[666] \quad F = M \frac{dV}{dt} \text{ for } a = \frac{dV}{dt},$$

and

$$F dt = M dV.$$

For the time  $t$  if  $V_0$  is the velocity when  $t = 0$  and  $V$  is the velocity after  $t$  seconds,

$$[667] \quad \int_0^t F dt = \int_{V_0}^V M dV,$$

or

$$\int_0^t F dt = MV - MV_0.$$

Consequently, during any period of time, the impulse of the resultant force acting upon a body is equal to its change of momentum.

It is now evident why these units of impulse and momentum are used, since problems involving force, mass, and velocity can be solved direct instead of using two sets of equations, one between force, mass, and acceleration and the other between velocity, acceleration, and time.

The sudden impulse of a force which acts for a very short interval of time is called *impact*.

**1058. Inertia.**—Inertia is that property of a body which causes it to offer resistance to any change in its condition of rest or uniform motion. Unless acted upon by some force, the body continues in its state of rest or uniform motion.

**1059. Moment of Inertia.**—The calculation of the kinetic energy of rotating bodies is made in terms of the *moment of inertia* of the body.

Consider four masses (not weights) connected by light wires to an axis of rotation. Let the masses be 5, 4, 3, and 2 units at distances of 2, 3, 4, and 5 feet from the axis, respectively, and consider the whole system to be rotating at the rate of  $\omega$  radians per second.

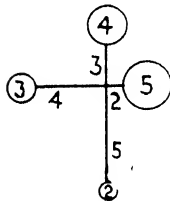

FIG. 643.

The 5-unit mass at 2 feet distance from the axis would have a linear velocity of  $2\omega$  feet per second. Therefore, its kinetic energy is

$$\frac{1}{2} \times 5 \times (2\omega)^2 = \frac{5}{2} \times 2^2\omega^2.$$

The total kinetic energy of the system would be the sum of the kinetic energies of the members, or

$$\begin{aligned} \text{Kinetic energy} &= \frac{1}{2}[5(2)^2 + 4(3)^2 + 3(4)^2 + 2(5)^2]\omega^2. \\ &= \frac{1}{2}(20 + 36 + 48 + 50)\omega^2 = \frac{1}{2}(154)\omega^2. \end{aligned}$$

But the total mass  $M = 2 + 3 + 4 + 5 = 14$ .

Dividing 154 by 14 = 11 =  $(3.317)^2$ .

Substituting,

$$\text{Kinetic energy} = \frac{1}{2} \cdot M(3.317)^2\omega^2.$$

Now, for convenience, the  $M(3.317)^2$  factor of the expression is called the *moment of inertia* of the group of rotating masses because if the masses were all concentrated at a distance of 3.317 feet from the axis of rotation, the kinetic energy of the system would remain unchanged. This distance (3.317) is called the *radius of gyration of the system*.

The moment of inertia is usually represented by  $I$ . From the foregoing, it will be seen that

$$[668] \quad \text{Kinetic energy of rotation} = \frac{I\omega^2}{2},$$

where

$I$  = moment of inertia of the system.

$\omega$  = angular velocity in radians.

EXAMPLE.—Find the moment of inertia of a solid wheel of uniform density and thickness about a perpendicular axis through the center.

If  $R$  is the outside radius of the wheel and  $M$  the mass of 1 square foot of area and thickness of the wheel, then divide the wheel into concentric rings whose width is  $\Delta r$  and whose radius is  $r$ .

The mass of one ring is  $M2\pi r \Delta r$ .

The moment of inertia of one ring is

$$(M2\pi r \Delta r)r^2,$$

or

$$2\pi Mr^3 \Delta r.$$

The moment of inertia of the whole wheel is the limit of the sum of the terms,

$$2\pi Mr^3 \Delta r,$$

for all the rings as  $\Delta r$  approaches zero as a limit and  $r$  varies between  $r = 0$  and  $r = R$ .

Therefore,

$$\text{Moment of inertia of wheel} = \int_0^R 2\pi Mr^3 dr = \frac{\pi MR^4}{2}.$$

The mass of the whole wheel =  $\pi MR^2$ .

Therefore,

$$\text{Moment of inertia} = \pi MR^2 \times \frac{R^2}{2},$$

or the energy of the rotating wheel is the same as if the entire mass were concentrated in a ring of radius,

$$\frac{R}{\sqrt{2}} = .707R.$$

The expression,  $\int x^2 dM$ , where  $dM$  denotes any differential of mass, each part of which is at  $x$  distance from the axis, is the general form for the moment of inertia. The sum of the differential masses equals the total mass. The expression  $\int x^2 dA$  is also called the second moment of the mass.

**1060. Moments of Inertia of an Area with Respect to Two Parallel Axes in the Plane of the Area.—**

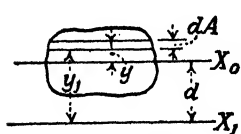

FIG. 645.

Let  $X_0$  be a centroidal axis of the area and  $X_1$  any other axis parallel to it at a distance  $d$  from it.

The moment of inertia with respect to  $X_1$ -axis is

$$I_{x_1} = \int y_1^2 dA.$$

$$(y_1)^2 = (y + d)^2 = y^2 + 2yd + d^2.$$

Substituting,

$$I_{x_1} = \int y^2 dA + 2d \int y dA + d^2 \int dA.$$

But

$$2d \int y dA = \text{moment of mass about } X_0 = 0,$$

because  $X_0$  passes through the center of gravity of the mass.

Then

$$[669] \quad I_{x_1} = I_{x_0} + Ad^2.$$

The moment of inertia of an area with respect to any axis in the plane of the area equals the moment of inertia of the area about an axis parallel to the given axis through the center of area, plus the product of the area and the square of the distance between the two axes.

EXAMPLE.—Given

$$I_{x_0} \text{ (for a rectangle) } = \frac{bh^3}{12}.$$

Find  $I$  with respect to the base.

$$I = I_{x_0} + Ad^2.$$

$$= \frac{bh^3}{12} + bh\left(\frac{h}{2}\right)^2 = \frac{bh^3}{12} + \frac{bh^3}{4} = \frac{bh^3}{3}.$$

**1061. Radius of Gyration.**—From Art. 1059,

$$I = \int x^2 dA = k^2 A,$$

where  $k$  is the radius of gyration or the distance from the axis at which the area would be considered as concentrated and the moment of inertia remain the same. From the above formula

$$[670] \quad k = \sqrt{\frac{I}{A}}.$$

**1062. Centroids.**—For any system of parallel forces, a resultant moment can be substituted for the moments of the forces, and

$$xR = F_1x_1 + F_2x_2 + F_3x_3 + \dots + F_nx_n,$$

or

$$x = \frac{F_1x_1 + F_2x_2 + F_3x_3 + \dots + F_nx_n}{R}.$$

If a line, area, or volume is divided into infinitesimal parts, the centroid, or center of gravity, can be determined by finding the center of resultant in the same manner as the resultant of several forces.

The centroid of a line of length  $s$ , if  $\bar{x}$  denotes the X-coordinate of the center of resultant, is

$$s\bar{x} = \lim_{\Delta s \rightarrow 0} [x_1\Delta s + x_2\Delta s + x_3\Delta s + \dots + x_n\Delta s] = \int x ds,$$



where  $\Delta s_i$  are infinitesimal elements of line at  $x_i$  distance from the origin. Then

$$[671] \quad \bar{x} = \frac{\int x ds}{s}, \quad \bar{y} = \frac{\int y ds}{s}, \quad \bar{z} = \frac{\int z ds}{s}.$$

EXAMPLE.—Find the coordinates of the center of gravity of a circular arc of radius  $r$  which subtends an angle of  $2\beta$  at the center.

Take  $OX$  on the line of symmetry. Then

$$\bar{y} = 0,$$

and the centroid will be on  $OX$ .

Use polar coordinates.

$$x = r \cos \theta, \quad ds = r d\theta,$$

$$s = 2r\beta.$$

Substituting these values in

$$\begin{aligned} \bar{x} &= \frac{\int x ds}{s} = \frac{2 \int_0^\beta r \cos \theta \cdot r d\theta}{2r\beta} = \frac{2 \int_0^\beta r^2 \cos \theta d\theta}{2r\beta} \\ &= \frac{2r^2 \sin \beta}{2r\beta} = \frac{r \sin \beta}{\beta}. \end{aligned}$$

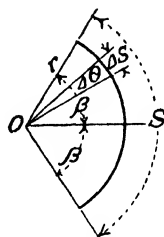

FIG. 646.

The Centroid of an Area,  $A$ .—From moments,

$$Ax = x_1\Delta A_1 + x_2\Delta A_2 + x_3\Delta A_3 + \dots + x_n\Delta A_n = \int x dA$$

and

$$[672] \quad \bar{x} = \frac{\int x dA}{A}, \quad \bar{y} = \frac{\int y dA}{A}, \quad \bar{z} = \frac{\int z dA}{A}.$$

EXAMPLE.—Find the center of gravity of a triangular plate of uniform thickness and density by moments, about an axis through the vertex parallel to the base.

The element of area,

$$\Delta A = y \Delta x,$$

is chosen because the entire triangle may be built up of strips of this kind.

From similar triangles,

$$\bullet \quad \frac{x}{y} = \frac{h}{b} \text{ and } y = \frac{bx}{h},$$

$$A = \frac{bh}{2} \text{ and } dA = y dx.$$

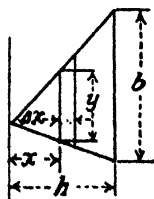

FIG. 647.

From

$$\begin{aligned}\bar{x} &= \frac{\int x dA}{A} = \frac{\int xy dx}{\frac{bh}{2}} = \frac{\int_0^h x \frac{bx}{h} dx}{\frac{bh}{2}} = \frac{\int_0^h \frac{bx^2}{h} dx}{\frac{bh}{2}} \\ &= \frac{\frac{bh^2}{3}}{\frac{bh}{2}} = \frac{2h}{3}.\end{aligned}$$

The center in the  $Y$ -direction is found in the same manner to be

$$\bar{y} = \frac{bh^2}{3}.$$

*The Center of Gravity of a Volume.*—From moments,

$$V\bar{x} = x_1\Delta V_1 + x_2\Delta V_2 + x_3\Delta V_3 + \dots + x_n\Delta V_n = \int x dV$$

and

$$[673] \quad \bar{x} = \frac{\int x dV}{V}, \quad \bar{y} = \frac{\int y dV}{V}, \quad \bar{z} = \frac{\int z dV}{V}.$$

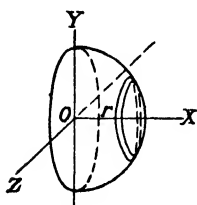

FIG. 648.

EXAMPLE.—Find the center of gravity of a hemisphere.

Selecting the axes as shown,

$$\bar{y} = 0 \text{ and } \bar{z} = 0,$$

$$V = \frac{2}{3}\pi r^3.$$

The elemental slice has an area of  $\pi y^2$  and is  $\Delta x$  thick, or

$$\Delta V = \pi y^2 \Delta x,$$

and since  $x^2 + y^2 = r^2$ ,

$$y^2 = r^2 - x^2.$$

From

$$\bar{x} = \frac{\int x dV}{V} \text{ and } dV = \pi y^2 dx,$$

substituting the above values,

$$\begin{aligned}\bar{x} &= \frac{\int_0^r x \pi y^2 dx}{\frac{2}{3}\pi r^3} = \frac{\int_0^r \pi x (r^2 - x^2) dx}{\frac{2}{3}\pi r^3} = \frac{\int_0^r r^2 x dx}{\frac{2}{3}\pi r^3} - \frac{\int_0^r x^3 dx}{\frac{2}{3}\pi r^3} \\ &= \frac{3r^4}{4r^3} - \frac{3r^4}{8r^3} = \frac{3}{8} r.\end{aligned}$$

## CHAPTER LVII .

### PARTIAL AND MULTIPLE INTEGRATION

**1063. Partial Integration.**—Partial integration is the reverse operation from partial differentiation. If given a differential expression involving two or more independent variables, we consider, when integrating, first only one as varying and the others as remaining constant. The result of this integration is again integrated considering another variable as varying and the others as remaining constant and so on.

Thus,

$$u = \iint f(x, y) dy dx$$

indicates that we are to find a function  $u$  of  $x$  and  $y$  such that

$$\frac{\partial^2 u}{\partial x \partial y} = f(x, y). \quad \text{Art. 987.}$$

If integrating first with respect to  $y$  regarding  $x$  as constant, the constant of integration may depend upon  $x$  or it may be a constant  $C$ .

Then

$$\frac{\partial u}{\partial x} = \int f(x, y) + \varphi(x)$$

or

$$\frac{\partial u}{\partial x} = \int f(x, y) + C.$$

Since the differentiation of either expression with respect to  $y$  gives the same result,  $f(x, y)$ , we, therefore, assume as a general case,

$$[674] \quad \frac{\partial u}{\partial x} = \int f(x, y) + \varphi(x),$$

where  $\varphi(x)$  is an arbitrary function of  $x$ .

**EXAMPLE.**—Given  $u = \iint e^{2x} y^2 dy dx$ . Find  $u$ .

$$\frac{\partial^2 u}{\partial x \partial y} = e^{2x} y^2.$$

Integrating first with respect to  $y$ , regarding  $x$  as constant,

$$\frac{\partial u}{\partial x} = \frac{1}{3}e^{2xy^3} + \varphi(x).$$

Integrating with respect to  $x$  with  $y$  constant,

$$u = \frac{1}{6}e^{2xy^3} + \int \varphi(x)dx + \psi(y),$$

or, since  $\varphi(x)$  was arbitrary,  $\int \varphi(x) dx$  is arbitrary so that

$$u = \frac{1}{6}e^{2xy^3} + \psi_1(x) + \psi_2(y),$$

where both  $\psi_1(x)$  and  $\psi_2(y)$  are arbitrary.

**1064. Geometrical Illustration for Partial Integration.**—Let  $z = f(x, y)$  be the rectangular equation of the surface  $CD$  (Fig. 649).

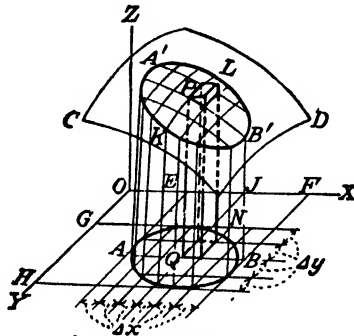

FIG. 649.

Take some area in the  $XY$ -plane, as  $AB$ , and construct a right cylinder  $ABA'B'$  with elements parallel to  $OZ$  and whose intersection with the  $z = f(x, y)$  surface is  $A'B'$ .

Draw perpendicular planes through the cylinder parallel to the  $ZY$ -plane  $\Delta x$  distance apart, and perpendicular planes through the cylinder parallel to the  $ZX$ -plane  $\Delta y$  distance apart. These planes cut the cylinder into a number of vertical columns having a curvilinear surface at the top and a base area of  $\Delta x \cdot \Delta y$ .

Consider the column  $PQ$  and let it be replaced by a prism  $PQ$  formed by passing a plane through  $P$  parallel to the  $XY$ -plane. The coordinates of  $P$  are  $(x, y, z)$  and the height of the prism is  $z$ , or  $f(x, y)$ , since  $z = f(x, y)$ . Therefore, the volume of the prism  $PQ$  is

$$f(x, y) \cdot \Delta x \cdot \Delta y.$$

By the principle of summation, then

$$\text{Volume of prisms} = \Sigma \Sigma f(x, y) \cdot \Delta x \cdot \Delta y.$$

Now if we increase the number of cutting planes and let  $\Delta x$  and  $\Delta y$  diminish indefinitely, then the sum of the volumes of the prisms will approach the volume of the cylinder, or

[675]  $V = \lim_{\substack{\Delta y \rightarrow 0 \\ \Delta x \rightarrow 0}} \Sigma \Sigma f(x, y) \cdot \Delta x \cdot \Delta y$ , which is equal to  $\int \int z dx dy$ .

**1065. Partial Integration. Another Method.**—The volume of the cylinder in the previous article can be found by considering the volume to be made up of numerous slices cut from the cylinder by planes parallel to the  $YZ$ -plane and  $\Delta x$  distance apart.

The value of  $z$  when  $x = OA$  in the equation,

$$z = f(x, y),$$

if the value of  $OA$  is substituted for  $x$  gives the intersection of the surface  $f(x, y)$ , and the plane  $BCDE$ , or the values of  $z$  along  $CD$ .

Hence the area

$$BCDE = \int_{AB}^{AE} f(OA, y) dy.$$

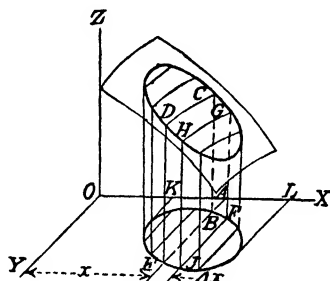

FIG. 650.

The volume of the slice with faces  $BCDE$  and  $FGHI$  is

$$\text{Area } BCDE \times \Delta x = \Delta x \int_{AB}^{AE} f(OA, y) dy.$$

The volume of the whole cylinder is the limit of the sum of all slices between  $K$  and  $L$ , or

$$V = \int_{OK}^{OL} dx \int_{AB}^{AE} f(x, y) dy.$$

$AE$  and  $AB$  are functions of  $x$ .

This formula is usually put into the form,

[676] 
$$V = \int_{a_2}^{a_1} \left[ \int_{u_1}^{u_2} f(x, y) dy \right] dx,$$

where  $u_1$  and  $u_2$  are functions of  $x$ , and  $a_1$  and  $a_2$  are the constant limits of  $x$ .

In the Solid Analytical Geometry section (Art. 847) concerning curve projections on coordinate planes, the equations of cylinders

were shown to be the same as the equations for the projections of the curve on the coordinate planes, and in following articles the  $x$  and  $y$  only will be considered and the  $z$  eliminated.

**1066. Plane Areas by Double Integration.**—Let  $y = f(x)$  be a given curve and we wish to apply the principle of double integration to the problem of finding the area under the curve. While a great many problems of this sort may be solved by a single integration, they may also be solved by double integration. In such cases, the best method is the application of double integration.

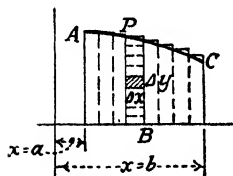

FIG. 651.

Consider the area between the curve  $AC$ , the ordinates  $x = a$  and  $x = b$ , and the  $X$ -axis. Divide the interval  $b - a$  into  $n$  very small strips, each  $\Delta x$  wide. Take any one of these strips, as  $PB$ , and cut it up into small rectangles  $\Delta y$  high. Then the area of each of these rectangles is  $\Delta x \cdot \Delta y$ . If we sum up these rectangles with respect to  $y$ , we shall have the area of the strip  $PB$ , or

$$\Delta x \sum_0^{f(x)} \Delta y = \text{area of } PB.$$

Now if we sum up these strips between the limits  $x = a$  and  $x = b$ , then

$$\sum_a^b \left[ \sum_0^{f(x)} \Delta y \right] \Delta x = \text{area of all the strips.}$$

Upon passing to the limit, first as  $\Delta y$  approaches zero and then as  $\Delta x$  approaches zero, we have the required area.

$$[677] \quad A = \int_a^b \int_0^{f(x)} dy dx.$$

Note that the inside integral sign belongs to  $dy$  and the outside sign to  $dx$ .

**EXAMPLE.**—Find by double integration the area of the circle,

$$x^2 + y^2 = a^2.$$

To simplify the solution, we will find the area of the first quadrant and multiply this result by 4.

In the first quadrant,

$$y = \sqrt{a^2 - x^2}.$$

Area of rectangle =

$$\text{Limit}_{\Delta y \rightarrow 0} \left[ \begin{matrix} y = \sqrt{a^2 - x^2} \\ y = 0 \end{matrix} \Sigma \Delta y \right] \Delta x = \left( \int_0^{\sqrt{a^2 - x^2}} dy \right) \Delta x.$$

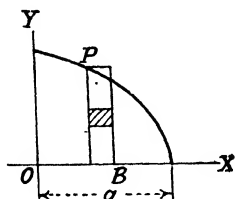

FIG. 652.

$$\begin{aligned} \text{Area of the sum of the strips} &= \text{Limit}_{\Delta x \rightarrow 0} \left[ \sum_{x=0}^x \left( \int_0^{\sqrt{a^2 - x^2}} dy \right) \Delta x \right] \\ &= \int_0^a \left( \int_0^{\sqrt{a^2 - x^2}} dy \right) dx = \int_0^a \int_0^{\sqrt{a^2 - x^2}} dy dx. \\ &= \int_0^a [y]_{y=0}^{y=\sqrt{a^2 - x^2}} dx = \int_0^a \sqrt{a^2 - x^2} dx = \\ &\quad \left[ \frac{x}{2} \sqrt{a^2 - x^2} + \frac{a^2}{2} \sin^{-1} \frac{x}{a} \right]_0^a = \frac{\pi a^2}{4}. \end{aligned}$$

The area of the circle is four times this result, or  $\pi a^2$ .

**1067. Area between Two Curves by Double Integration.**—It will readily be seen that, by subtracting the single integral of  $F(x)$  from the single integral of  $f(x)$ , the result will be the area between the curves but this same result can be found by double integration.

Consider the element of area  $\Delta x \Delta y$  as before. Then the area of the strip  $PQ$  is

$$\Delta x \sum_{F(x)}^{f(x)} \Delta y.$$

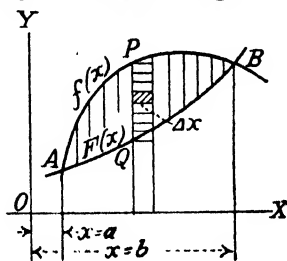

FIG. 653.

The summation of the strips from  $A$  to  $B$  between the limits  $x = a$  and  $x = b$  is

$$\sum_a^b \left[ \sum_{F(x)}^{f(x)} \Delta y \right] \Delta x = \sum_a^b \sum_{F(x)}^{f(x)} \Delta y \Delta x.$$

Passing to the limits, first as  $\Delta y$  approaches zero and then as  $\Delta x$  approaches zero, then

$$[678] \quad \text{Area} = \int_a^b \int_{F(x)}^{f(x)} dy dx$$

This will reduce to the same form as for single integration, for

$$\int_{F(x)}^{f(x)} dy = [y]_{F(x)}^{f(x)} = f(x) - F(x).$$

Then

$$\int_a^b \int_{F(x)}^{f(x)} dy dx = \int_a^b [f(x) - F(x)] dx = \int_a^b f(x) dx - \int_a^b F(x) dx.$$

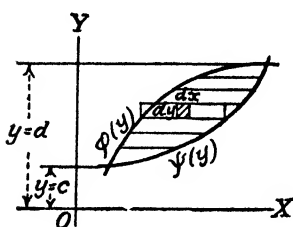

FIG. 654.

Again, we might desire to sum up the area first with respect to  $x$  and then with respect to  $y$ . Then

$$[679] \quad \text{Area} = \int_c^d \int_{\varphi(y)}^{\psi(y)} dx dy,$$

where  $\psi(y)$  and  $\varphi(y)$  are the inverse functions of  $f(x)$  and  $F(x)$ .

EXAMPLE.—Find by double integration the area between the parabolas,  $y^2 = x$  and  $y = x^2$ .

Applying formula,

$$\text{Area} = \int_a^b \int_{F(x)}^{f(x)} dy dx \quad [678].$$

First write the integral of the strip  $PQ$  with limits, as

$$\int_{y=F(x)}^{y=f(x)} dy = \int_{x^2}^{\sqrt{x}} dy.$$

Next solve as simultaneous equations to find the limits, which are 1 and 0.

Now the next operation, or the summation of strips from  $a$  to  $b$  or from 0 to 1, is done by affixing the integral sign with the proper limits, which gives

$$\int_{x=0}^{x=1} \int_{y=x^2}^{y=\sqrt{x}} dy dx.$$

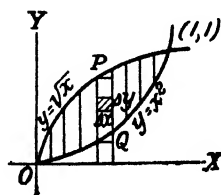

FIG. 655.

Integrating first with respect to  $y$ ,

$$\int_0^1 [y]_{x^2}^{\sqrt{x}} dx = \int_0^1 (\sqrt{x} - x^2) dx = \int_0^1 x^{\frac{1}{2}} dx - \int_0^1 x^2 dx.$$

Integrating with respect to  $x$ ,

$$\int_0^1 x^{\frac{1}{2}} dx - \int_0^1 x^2 dx = \left[ \frac{2x^{\frac{3}{2}}}{\frac{3}{2}} - \frac{x^3}{3} \right]_0^1 = \frac{2}{3} - \frac{1}{3} = \frac{1}{3}.$$



**1068. Graphical Solution of Previous Problem.**—The problem of finding the area between the two curves,  $y^2 = x$  and  $x^2 = y$  may be solved graphically as follows:

After plotting the curves, consider the strips .2 unit wide and draw the horizontal lines averaging the triangular areas as shown. Set the proportional divider to the ratio of 5:1 since each strip is .2 unit wide.

The integral curves are  $OA$  and  $OB$ . Since ordinate  $AC$  represents to the given vertical scale the area under the  $y^2 = x$  curve, and the ordinate  $BC$  represents the area between the  $y = x^2$  curve and the  $X$ -axis, then the difference of the ordinates, or  $AB$ , represents the difference of these areas or the area between the curves. In practice it is not necessary to shade the triangular areas.

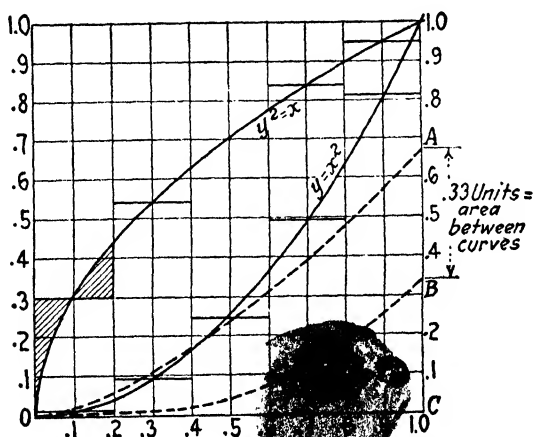

FIG. 6

**EXAMPLE.**—Find the area between the parabola,

$$y^2 = 4x + 4a^2,$$

and the straight line,  $y = 2a - x$ .

Solving simultaneously, the parabola and the line intersect at

$$A(0, 2a) \text{ and } B(8a, -6a).$$

Draw the strips as shown and use the form,

$$\text{Area} = \int_{y=c}^{y=d} \int_{x=\varphi(y)}^{x=\psi(y)} dx dy \quad [679].$$

From  $y^2 = 4ax + 4a^2$ ,

$$x = \frac{y^2 - 4a^2}{4a}$$

From  $y = 2a - x$ ,

$$x = 2a - y.$$

Setting up the integrals,

$$A = \int_{-6a}^{2a} \int_{\frac{y^2 - 4a^2}{4a}}^{2a - y} dx dy = \int_{-6a}^{2a} \left( 2a - y - \frac{y^2 - 4a^2}{4a} \right) dy = \frac{64}{3} a^2.$$

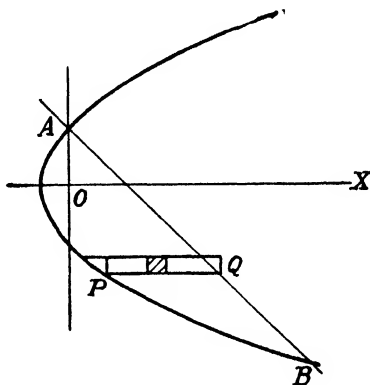

FIG. 657.

If the expression is integrated first with respect to  $y$ , the problem is much more difficult. The vertical strips to the left of the  $Y$ -axis will be bounded by the parabola curve only and should be set up separately from the area to the right of the  $Y$ -axis.

For the area to the left of the  $Y$ -axis,

$$\begin{aligned} 2 \int_{x=-a}^{x=0} \int_{y=0}^{y=2\sqrt{ax+a^2}} dy dx &= 2 \int_{-a}^0 \sqrt{ax+a^2} dx = \\ &= \frac{2 \times 2}{a} \left| \frac{(ax+a^2)^{\frac{3}{2}}}{3} \right|_{-a}^0 = \frac{4a^2}{3}. \end{aligned}$$

For the area to the right of the  $Y$ -axis,

$$\begin{aligned} \int_{x=0}^{x=8a} \int_{y=-2\sqrt{ax+a^2}}^{y=2a-x} dy dx &= \\ \int_0^{8a} 2ax - \frac{x^2}{2} + \frac{4}{3a}(ax+a^2)^{\frac{3}{2}} dx &= \\ 16a^2 - 32a^2 + 36a^2 &= 20a^2. \end{aligned}$$

$$\text{Total area} = \frac{4a^2}{3} + 20a^2 = \frac{64}{3} a^2, \text{ as before.}$$

**1069. Plane Areas by Double Integration. Polar Coordinates.**  
 Let  $\rho = f(\theta)$  be the equation of the curve and we wish to find the area between the radius vectors,  $\rho_1$  and  $\rho_2$ , and the curve.

Let us consider the element of area (Fig. 659).

From elementary geometry,

$$\text{Sector } AOC = \frac{1}{2}\rho \times \rho\Delta\theta = \frac{1}{2}\rho^2\Delta\theta.$$

$$\text{Sector } BOD = \frac{1}{2}(\rho + \Delta\rho)^2\Delta\theta.$$

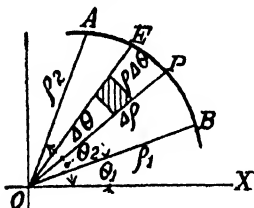

FIG. 658.

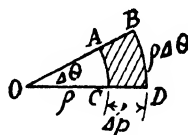

FIG. 659.

Hence, area  $ABCD =$

$$\frac{1}{2}(\rho + \Delta\rho)^2\Delta\theta - \frac{1}{2}\rho^2\Delta\theta = (\rho + \frac{1}{2}\Delta\rho)\Delta\theta\Delta\rho.$$

If we keep  $\Delta\theta$  constant and make our summation with respect to  $\rho$ , we have the area of the sector  $POE$ , which is

$$\Delta\theta \lim_{\Delta\rho \rightarrow 0} \sum_{\rho=0}^{\rho=f(\theta)} (\rho + \frac{1}{2}\Delta\rho)\Delta\rho = \Delta\theta \int_{\rho=0}^{\rho=f(\theta)} \rho d\rho.$$

Now if we make a summation with respect to  $\theta$ , we get the sum of the wedge-shaped areas, or

$$A = \lim_{\Delta\theta \rightarrow 0} \sum_{\theta_1}^{\theta_2} \Delta\theta \int_{\rho=0}^{\rho=f(\theta)} \rho d\rho = \int_{\theta_1}^{\theta_2} \int_{\rho=0}^{\rho=f(\theta)} \rho d\rho d\theta.$$

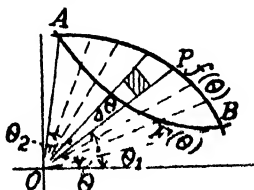

FIG. 660

In the same manner as found in double integration using rectangular coordinates for the area between two curves, the polar area between two curves may be found.

The expression for this area takes the form,

$$[680] \quad A = \int_{\theta_1}^{\theta_2} \int_{\rho=F(\theta)}^{\rho=f(\theta)} \rho d\rho d\theta.$$

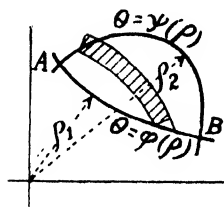

FIG. 661.

If the summation is made first with respect to  $\theta$  keeping  $\Delta\rho$  constant, we obtain a segment of a circular ring as is shown in Fig. 661.

The limit of the sum of these circular segments is

$$[681] \quad A = \int_{\rho_1}^{\rho_2} \int_{\theta=\varphi(\rho)}^{\theta=\psi(\rho)} \rho d\theta d\rho.$$

EXAMPLE.—Find the area between two circles tangent internally and having radii  $r_1$  and  $r_2$ , respectively.

From trigonometry,

$$\rho_1 = 2r_1 \cos \theta.$$

$$\rho_2 = 2r_2 \cos \theta.$$

Integrating between  $\frac{\pi}{2}$  and 0 as limits, then for half the area,

$$\frac{1}{2}A = \int_0^{\frac{\pi}{2}} \int_{\rho_1=2r_1 \cos \theta}^{\rho_2=2r_2 \cos \theta} \rho d\rho d\theta.$$

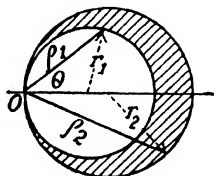

FIG. 662.

Then

$$\begin{aligned} \frac{1}{2}A &= \int_0^{\frac{\pi}{2}} \left[ \frac{\rho^2}{2} \right]_{2r_1 \cos \theta}^{2r_2 \cos \theta} d\theta = \int_0^{\frac{\pi}{2}} \left[ \frac{4(r_2)^2 \cos^2 \theta - 4(r_1)^2 \cos^2 \theta}{2} \right] d\theta. \\ &= \int_0^{\frac{\pi}{2}} 2[(r_2)^2 - (r_1)^2] \cos^2 \theta d\theta. \\ &= 2[(r_2)^2 - (r_1)^2] \left[ \frac{\theta}{2} + \frac{\sin 2\theta}{4} \right]_0^{\frac{\pi}{2}}. \\ &= 2[(r_2)^2 - (r_1)^2] \left[ \frac{\pi}{4} + \frac{1}{4} \sin \pi \right] \quad (\sin \pi = 0). \\ &= \frac{\pi}{2} [(r_2)^2 - (r_1)^2]. \end{aligned}$$

Since this is the expression for half the area, the whole area is

$$A = \pi [(r_2)^2 - (r_1)^2].$$

**1070. Moment of Area by Double Integration.**—Consider an element of the area as  $PQ$  with the coordinates of  $P$ , as  $(x, y)$ . The area of this element is  $\Delta x \Delta y$ . The moment of this area about the  $Y$ -axis is the area of the element times its distance from the axis, or  $\Delta x \Delta y$  times  $x$  equals

$$x \cdot \Delta x \Delta y.$$

Form a similar product for every element within the boundary of the full area  $AB$ , and add these elements by double summation. Then

$$M_y = \lim_{\substack{\Delta y \rightarrow 0 \\ \Delta x \rightarrow 0}} \sum \sum x \Delta y \Delta x = \iint x dy dx,$$

which is the moment of area with respect to the  $Y$ -axis.

In the same manner find the moment of the area with respect to the  $X$ -axis. This moment, then, is

[682] 
$$M_x = \iint y dy dx.$$

The limits of integration are applied to these formulae similar to the case of the area.

Then

[683] 
$$M_y = \int_{x=a}^{x=b} \int_{y=F(x)}^{y=f(x)} x dy dx,$$

and

[684] 
$$M_x = \int_{x=a}^{x=b} \int_{y=F(x)}^{y=f(x)} y dy dx.$$

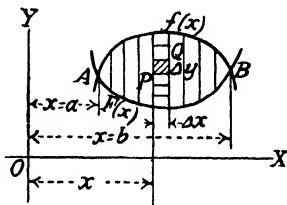

FIG. 663.

**1071. Centroids by Double Integration.**—If we consider that the area under consideration is concentrated at a point  $(\bar{x}, \bar{y})$ , such that the moment of the area is unchanged, this point is called the center of mass or center of gravity. From this,

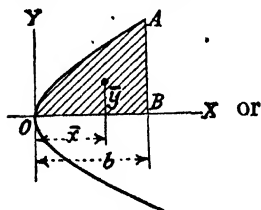

FIG. 664.

$$M_y = \text{area} \times \bar{x},$$

$$M_x = \text{area} \times \bar{y},$$

$$\bar{x} = \frac{M_y}{\text{area}}, \quad \bar{y} = \frac{M_x}{\text{area}},$$

[685] 
$$\bar{x} = \frac{\int_{x=a}^{x=b} \int_{y=F(x)}^{y=f(x)} x dy dx}{\int_a^b \int_{F(x)}^{f(x)} dy dx}, \quad \bar{y} = \frac{\int_{x=a}^{x=b} \int_{y=F(x)}^{y=f(x)} y dy dx}{\int_a^b \int_{F(x)}^{f(x)} dy dx}.$$

In the same manner, the equations in polar coordinates are developed. Since  $x = \rho \cos \theta$  and  $y = \rho \sin \theta$ , then the area element becomes  $\rho \cdot \Delta\rho\Delta\theta$  and the formulae are

$$[686] \quad \bar{x} = \frac{\int_{\theta_1}^{\theta_2} \int_{\rho=F(\theta)}^{\rho=f(\theta)} \rho^2 \cos \theta d\rho d\theta}{\int_{\theta_1}^{\theta_2} \int_{F(\theta)}^{f(\theta)} \rho d\rho d\theta}, \quad \bar{y} = \frac{\int_{\theta_1}^{\theta_2} \int_{\rho=F(\theta)}^{\rho=f(\theta)} \rho^2 \sin \theta d\rho d\theta}{\int_{\theta_1}^{\theta_2} \int_{F(\theta)}^{f(\theta)} \rho d\rho d\theta}.$$

✓EXAMPLE.—Find the center of gravity of the area bounded by

$$y^2 = 4x, \quad x = 4, \quad \text{and} \quad y = 0.$$

$$M_y = \int_0^4 \int_0^{2x^{\frac{1}{2}}} x dy dx = \int_0^4 [x \cdot y]_{y=0}^{y=2\sqrt{x}} dx = \int_0^4 x \cdot 2\sqrt{x} dx.$$

$$= \int_0^4 2x^{\frac{3}{2}} dx = \left[ \frac{4x^{\frac{5}{2}}}{5} \right]_0^4 = \frac{128}{5}.$$

$$M_x = \int_0^4 \int_{y=0}^{y=2x^{\frac{1}{2}}} y dy dx = \int_0^4 \left[ \frac{y^2}{2} \right]_{y=0}^{y=2\sqrt{x}} dx = \int_0^4 2x dx = \left[ x^2 \right]_0^4 = 16.$$

$$\text{Area} = \int_0^4 \int_0^{2\sqrt{x}} dy dx = \int_0^4 y dx = \int_0^4 2\sqrt{x} dx = \left[ \frac{4x^{\frac{3}{2}}}{3} \right]_0^4 = \frac{32}{3}.$$

Substituting these values in the formulae of Art. 1071,

$$\bar{x} = \frac{\frac{128}{5}}{\frac{32}{3}} = \frac{12}{5}, \quad \bar{y} = \frac{16}{\frac{32}{3}} = \frac{3}{2}.$$

### 1072. Location of Centroids or Centers of Gravity.

Triangular area

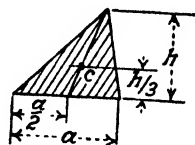

FIG. 665.

Semicircular area

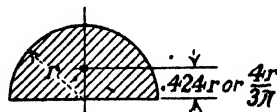

FIG. 666.

Semicircular arc

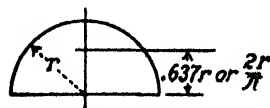

FIG. 667.

Parabolic segment

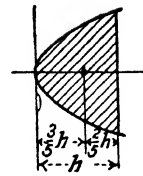

FIG. 668.

Semiparabolic segment

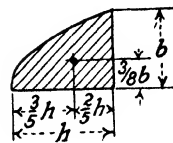

FIG. 669.

Area over parabolic curve

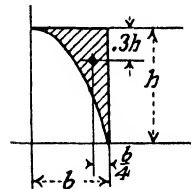

FIG. 670.

Quadrant of circle

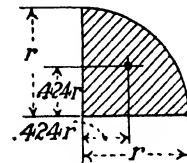

FIG. 671.

Fillet-shaped area

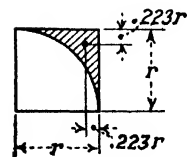

FIG. 672.

Trapezoid

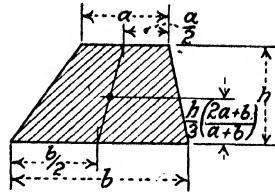

FIG. 673.

Trapezoid

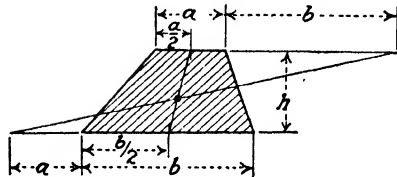

FIG. 674.

Quadrilateral area

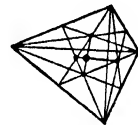

FIG. 675.

**1073. Moment of Inertia of Plane Areas by Double Integration.**—If we consider an element of the area as  $PQ$ , with coordinates of  $P$  as  $(x, y)$ , multiplying the element  $\Delta x \Delta y$  by the square of the distance gives the product,

$$x^2 \Delta y \Delta x,$$

which is called the *moment of inertia* of the element with respect to the  $Y$ -axis.

If we form similar products for each element and add all such products by a double summation, then

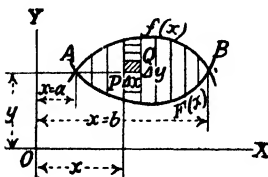

FIG. 676.

$$\text{Limit}_{\substack{\Delta y \rightarrow 0 \\ \Delta x \rightarrow 0}} \sum \sum x^2 \Delta y \Delta x = \iint x^2 dy dx.$$

If we apply the limits as in the case of the area, then

[687] 
$$I_y = \int_a^b \int_{y=F(x)}^{y=f(x)} x^2 dy dx,$$

which is the moment of inertia of the area  $AB$  with respect to the  $Y$ -axis.



In the same manner, the moment of inertia with respect to the  $X$ -axis is

[688] 
$$I_x = \int_a^b \int_{y=F(x)}^{y=f(x)} y^2 dy dx.$$

The only difference is the substitution of  $y^2$  for  $x^2$ .

**1074. Polar Moment of Inertia. Rectangular Coordinates.**

The moment of inertia about an axis perpendicular to the plane of the area is determined by double integration.

If  $P(x, y)$  is a point in the element of area  $\Delta y \Delta x$ , then the distance from  $P$  to  $O$  is

$$\sqrt{x^2 + y^2}.$$

If now the area element  $\Delta y \Delta x$  be multiplied by the square of its distance from  $O$ , which gives the polar moment of inertia of the element, then we have

$$(x^2 + y^2) \Delta y \Delta x.$$

The summation of all the elements gives

$$\lim_{\substack{\Delta y \rightarrow 0 \\ \Delta x \rightarrow 0}} \sum \sum (x^2 + y^2) \Delta y \Delta x = \iint (x^2 + y^2) dy dx.$$

Introducing the limits, then

$$I_0 = \int_a^b \int_{y=F(x)}^{y=f(x)} (x^2 + y^2) dy dx,$$

which is the equation for the polar moment of inertia where  $I_0$  denotes this polar moment.

From the above equations,

[689] 
$$I_0 = \iint (x^2 + y^2) dy dx = \iint x^2 dy dx + \iint y^2 dy dx.$$

Comparing with the rectangular formulae,

$$I_0 = I_x + I_y.$$

EXAMPLE.—Find  $I_0$  over the area bounded by the lines,

$$x = a, y = 0, y = \frac{b}{a}x.$$

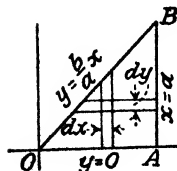

FIG. 678.

The given lines form the triangle  $OAB$ . Summing up the vertical strip, the  $y$  limits are

$$\frac{b}{a}x \text{ and } 0.$$

Summing up the strips in the triangle, the  $x$  limits are  $a$  and  $0$ .

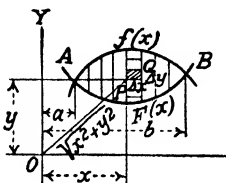

FIG. 677.

Then from

$$I_0 = \int \int (x^2 + y^2) dy dx, \quad [689]$$

$$\begin{aligned} I_0 &= \int_0^a \int_0^{\frac{b}{a}x} (x^2 + y^2) dy dx = \int_0^a \left[ x^2 y + \frac{y^3}{3} \right]_0^{\frac{b}{a}x} dx = \\ &= \int_0^a \left[ \frac{b}{a} + \frac{b^3}{3a^3} \right] x^3 dx = \left[ \left( \frac{b}{a} + \frac{b^3}{3a^3} \right) \frac{x^4}{4} \right]_0^a = \left( \frac{b}{a} + \frac{b^3}{3a^3} \right) \frac{a^4}{4} \\ &= ab \left( \frac{a^2}{4} + \frac{b^2}{12} \right). \end{aligned}$$

**1075. Polar Moment of Inertia by Double Integration.**  
**Polar Coordinates.**—The element of area in this case is  $\rho \cdot \Delta\rho\Delta\theta$  (see Art. 1069) on the area in polar coordinates. We also have the relation,

$$\rho^2 = x^2 + y^2,$$

which substituted in equation for polar moment in rectangular coordinates,

$$I_0 = \int \int (x^2 + y^2) dy dx,$$

gives

$$I_0 = \int \int \rho^3 d\rho d\theta.$$

Introducing the limits,

$$[690] \quad I_0 = \int_{\theta_1}^{\theta_2} \int_{\rho=F(\theta)}^{\rho=f(\theta)} \rho^3 d\rho d\theta,$$

which is the equation of the polar moment of inertia in polar coordinates.

**EXAMPLE.**—Find  $I_0$  over the region bounded by the circle,

$$\rho = 2r \cos \theta.$$

Substituting in formula,

$$\begin{aligned} I_0 &= \int_{-\frac{\pi}{2}}^{\frac{\pi}{2}} \int_{\rho=0}^{\rho=2r \cos \theta} \rho^3 d\rho d\theta, \\ &= \int_{-\frac{\pi}{2}}^{\frac{\pi}{2}} \left[ \frac{\rho^4}{4} \right]_{\rho=0}^{\rho=2r \cos \theta} d\theta. \\ &= \int_{-\frac{\pi}{2}}^{\frac{\pi}{2}} 4r^4 \cos^4 \theta d\theta. \end{aligned}$$

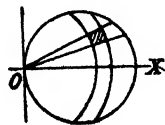

FIG. 679.

$$\begin{aligned}
 &= 4r^4 \int_{-\frac{\pi}{2}}^{\frac{\pi}{2}} \cos^4 \theta d\theta = 4r^4 \left[ \frac{\cos^3 \theta \cdot \sin \theta}{4} + \frac{3}{4} \int \cos^2 \theta d\theta \right]. \\
 &= 4r^4 \left[ \frac{\cos^3 \theta \cdot \sin \theta}{4} + \frac{3}{4} \left( \frac{\theta}{2} + \frac{1}{4} \sin 2\theta \right) \right]_{-\frac{\pi}{2}}^{\frac{\pi}{2}}. \\
 &= 4r^4 \left[ 0 + \frac{3\pi}{16} + 0 \right] - \left[ -\frac{3\pi}{16} \right] = 4r^4 \cdot \frac{3\pi}{8} = \frac{3r^4\pi}{2}.
 \end{aligned}$$

**1076. Areas of Surfaces by Double Integration.**—If  $z = f(x, y)$

is the equation of the surface  $CB$ , and we desire to find the area  $A$  on the surface:

Let  $A'$  be the orthogonal projection of  $A$  on the  $XY$ -plane.

Pass planes parallel to the  $YZ$ - and  $ZX$ -planes at common distances  $\Delta x$  and  $\Delta y$ . These planes form truncated prisms bounded at the top by an element of area whose projection on the  $XY$ -plane is  $\Delta x \Delta y$ .

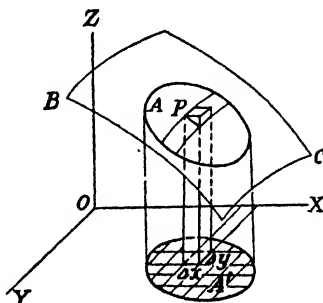

FIG. 680.

Consider the plane tangent to the surface at  $P$ . From analytical geometry, Area of element  $\Delta x \Delta y =$  Area of tangent plane element  $\times \cos \gamma$ , where  $\gamma$  is the angle which the tangent plane makes with the  $XY$ -plane. Then

$$\Delta x \Delta y = \text{Area of tangent plane element} \times \cos \gamma.$$

But

$$\cos \gamma = \frac{1}{\left[ 1 + \left( \frac{\partial z}{\partial x} \right)^2 + \left( \frac{\partial z}{\partial y} \right)^2 \right]^{\frac{1}{2}}}$$

Hence,

$$\Delta x \Delta y = \frac{\text{Area of tangent plane element}}{\left[ 1 + \left( \frac{\partial z}{\partial x} \right)^2 + \left( \frac{\partial z}{\partial y} \right)^2 \right]^{\frac{1}{2}}}$$

Then

$$\text{Area of tangent plane element} = \left[ 1 + \left( \frac{\partial z}{\partial x} \right)^2 + \left( \frac{\partial z}{\partial y} \right)^2 \right]^{\frac{1}{2}} \Delta x \Delta y.$$

Making a summation of all the tangent plane elements,

$$\lim_{\substack{\Delta y \rightarrow 0 \\ \Delta x \rightarrow 0}} \Sigma \Sigma \left[ 1 + \left( \frac{\partial z}{\partial x} \right)^2 + \left( \frac{\partial z}{\partial y} \right)^2 \right]^{\frac{1}{2}} \Delta x \Delta y.$$

Then

$$[691] \quad \text{Area} = \iint \left[ 1 + \left( \frac{\partial z}{\partial x} \right)^2 + \left( \frac{\partial z}{\partial y} \right)^2 \right]^{\frac{1}{2}} dy dx.$$

Introducing the limits of integration,

$$[692] \quad \text{Area} = \int_{x=a}^{x=b} \int_{y=F(x)}^{y=f(x)} \left[ 1 + \left( \frac{\partial z}{\partial x} \right)^2 + \left( \frac{\partial z}{\partial y} \right)^2 \right]^{\frac{1}{2}} dy dx,$$

where  $y = f(x)$  and  $y = F(x)$  are the projections on the  $XY$ -plane of the boundary curves of the area.

If it is more convenient to project the area onto the  $XZ$ -plane, the formula becomes

$$[693] \quad \text{Area} = \int_{x=a}^{x=b} \int_{z=\psi(x)}^{z=\varphi(x)} \left[ 1 + \left( \frac{\partial y}{\partial x} \right)^2 + \left( \frac{\partial y}{\partial z} \right)^2 \right]^{\frac{1}{2}} dz dx.$$

For the projection on the  $YZ$ -plane,

$$[694] \quad \text{Area} = \int_{y=c}^{y=d} \int_{z=\sigma(y)}^{z=G(y)} \left[ 1 + \left( \frac{\partial x}{\partial y} \right)^2 + \left( \frac{\partial x}{\partial z} \right)^2 \right]^{\frac{1}{2}} dz dy.$$

It might be well to recall the method of finding the projection of the area on the  $XY$ -plane (see Analytical Geometry section Art. 847). By eliminating  $z$  between the equations of the surfaces whose intersections form the boundary of the area, the equation of the projection of this curve on the  $XY$ -plane is found.

EXAMPLE.—Find the area of the surface of the sphere,

$$x^2 + y^2 + z^2 = r^2.$$

Consider one-eighth of the surface, that is, the area included in one quadrant between the coordinate planes.

From the equation,

$$x^2 + y^2 + z^2 = r^2,$$

$$\frac{\partial z}{\partial x} = -\frac{x}{z}$$

$$\frac{\partial z}{\partial y} = -\frac{y}{z}$$

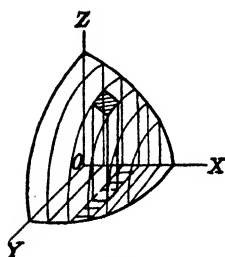

FIG. 681.

Then

$$\begin{aligned} 1 + \left( \frac{\partial z}{\partial x} \right)^2 + \left( \frac{\partial z}{\partial y} \right)^2 &= 1 + \frac{x^2}{z^2} + \frac{y^2}{z^2} = \frac{z^2}{z^2} + \frac{x^2}{z^2} + \frac{y^2}{z^2} \\ &= \frac{x^2 + y^2 + z^2}{z^2} = \frac{r^2}{r^2 - x^2 - y^2}. \end{aligned}$$

By making  $z = 0$ , we get the projection of the area on the  $XY$ -plane, or

$$x^2 + y^2 = r^2.$$

Forming our equation from

$$\begin{aligned} \frac{A}{8} &= \int_{x=a}^{x=b} \int_{y=F(x)}^{y=f(x)} \left[ \frac{r^2}{r^2 - x^2 - y^2} \right]^{\frac{1}{2}} dy dx, \\ &= \int_{x=0}^{x=r} \int_{y=0}^{y=\sqrt{r^2-x^2}} \left[ \frac{r}{\sqrt{r^2-x^2-y^2}} \right] dy dx = \frac{\pi r^2}{2}, \end{aligned}$$

or

$$A = 4\pi r^2.$$

**1077. Volumes by Triple Integration.**—Volumes bounded by surfaces with given equations can be calculated by three successive integrations in the same method as that used in double integration.

First, divide the solid into rectangular parallelepipeds having dimensions  $\Delta x \Delta y \Delta z$ . Then the volume of each one is

$$\Delta x \cdot \Delta y \cdot \Delta z,$$

which is the element of volume.

Sum all of these elements within the boundaries of the given surfaces by first taking the elements of a column, then the sum of all such columns to form slices, and finally sum the slices into the full volume.

Then

$$[695] \quad V = \lim_{\substack{\Delta z \rightarrow 0 \\ \Delta y \rightarrow 0 \\ \Delta x \rightarrow 0}} \Sigma \Sigma \Sigma \Delta x \Delta y \Delta z = \int \int \int dz dy dx.$$

Consider the limits of integration when finding the volume of the ellipsoid,

$$\sqrt{x^2/a^2 + y^2/b^2 + z^2/c^2} = 1,$$

which lies in the first quadrant.

Consider, first, the limits of the summation of the elements,

$$\Delta x \cdot \Delta y \cdot \Delta z,$$

as they are summed into columns. The  $Y$   $z$  limits are from  $z = 0$  to  $z =$

$$c \sqrt{1 - \frac{x^2}{a^2} - \frac{y^2}{b^2}}.$$

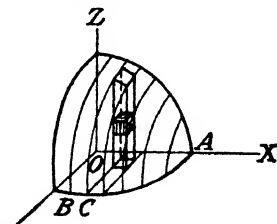

FIG. 682.

The summation of the columns into slices with respect to  $y$  is between the limits,

$$y = 0 \text{ and } y = b\sqrt{1 - \frac{x^2}{a^2}}.$$

Since this boundary curve lies in the  $XY$ -plane, it is found from the equation,

$$\frac{x^2}{a^2} + \frac{y^2}{b^2} + \frac{z^2}{c^2} = 1,$$

by making  $z = 0$ .

Now the limits of the summation, as we sum the slices into the volume with respect to  $x$ , are between

$$x = 0 \text{ and } x = OA = a.$$

We are now in a position to form the equation,

$$V = \int_{x=0}^{x=a} \int_{y=0}^{y=b\sqrt{1-\frac{x^2}{a^2}}} \int_{z=0}^{z=c\sqrt{1-\frac{x^2}{a^2}-\frac{y^2}{b^2}}} dz dy dx.$$

$$\begin{aligned} V &= c \int_{x=0}^{x=a} \int_{y=0}^{y=b\sqrt{1-\frac{x^2}{a^2}}} \sqrt{1-\frac{x^2}{a^2}} \left(1 - \frac{x^2}{a^2} - \frac{y^2}{b^2}\right)^{\frac{1}{2}} dy dx. \\ &= \frac{\pi cb}{4a^2} \int_{x=0}^{x=a} (a^2 - x^2) dx = \frac{\pi abc}{6}. \end{aligned}$$

$$\text{Volume of the entire ellipsoid} = \frac{4\pi abc}{3}.$$

The usual notation is

$$V = \int_0^a \int_0^{y=\varphi(x)} \int_0^{z=f(x,y)} dz dy dx.$$

It will be observed that the limits for integration with respect to  $x$  and  $y$  are the same as those that we use in finding the area  $ACBO$  in the  $XY$ -plane, or the projection of the given solid on the  $XY$ -plane, as

$$A = \int_0^a \int_{y=0}^{y=\varphi(x)} dy dx.$$

This means that we can find the required volume by double integration, thus,

$$V = \int_0^a \int_{y=0}^{y=\varphi(x)} z dy dx,$$

which is the same as integrating the triple integral with respect to  $z$ .

**1078. Comparison of Single and Double Integration.**—In Art. 997 and again in Arts. 1011 and 1036, the area by single integration was shown to be

$$A = \int y dx.$$

In Art. 1066, the area by double integration was shown to be

$$A = \iint dy dx.$$

We can reduce this last expression to the first one by integrating first with respect to  $y$ . Then

$$A = \int y dx.$$

### SUMMARY

**1079. Moments by Summation Method.**—Divide into elements a given geometrical magnitude, such as a line, a surface, or a solid. The line would be divided into elements of length, the surface into elements of area, and the solid into elements of volume.

Let each of these elements,  $\Delta s$ ,  $\Delta A$ , or  $\Delta V$ , be multiplied by its distance from chosen point, or reference line, or plane. This is the moment of the element about the chosen point, line, or plane. The limit of the sum of the products of all the elements times their distances from the reference as the elements are allowed to decrease in magnitude indefinitely is called the *first moment* of the geometrical magnitude.

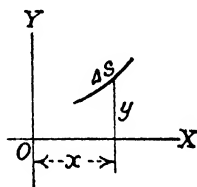

FIG. 683.

$$\begin{aligned} M_x &= \text{Limit}_{\Delta s \rightarrow 0} \sum y \Delta s. \\ &= \int y ds. \\ &= \text{moment of a line.} \end{aligned}$$

In the same manner, the moment of a plane area about the  $X$ -axis is

$$\begin{aligned} M_x &= \text{Limit}_{\Delta A \rightarrow 0} \sum y \Delta A. \\ &= \int y dA. \end{aligned}$$

Also, since

$$\Delta A = Ax \cdot \Delta y,$$

then

$$\int y dA = \iint y dx dy,$$

which gives the equivalent form for double integration (see Art. 1070):

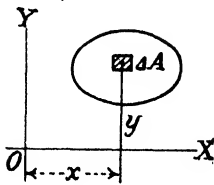

FIG. 684.

For the first moment with respect to one of the coordinate planes, as the  $XY$ -plane, of a solid, the formula is

$$M_{xy} = \lim_{\Delta V \rightarrow 0} \sum z \Delta V = \int z dV.$$

For  $\Delta s$ ,  $\Delta A$ , and  $\Delta V$ , proper length, area, or volume elements must be substituted before integrating.

Also,

$$\Delta V = \Delta x \cdot \Delta y \cdot \Delta z.$$

Then

$$\int z dV = \iint \int z dz dy dx.$$

It will be seen that by substituting  $\sqrt{(dy)^2 + (dx)^2}$  for  $ds$ ,  $dydx$  for  $dA$  and  $dzdydx$  for  $dV$ , the formulae for single integrations can be transformed into those for double and triple integrations.

**1080. Approximate Integration.**—*The trapezoidal rule* makes use of the trapezoidal areas for areas under a curve instead of the rectangular areas, which makes the approximation nearer the exact area. Divide the distance from  $a$  to  $b$  into any number  $n$  of equal spaces. The greater the value of  $n$  used, the closer the computed area comes to being the exact area. The area of the trapezoid is one-half the sum of the parallel sides multiplied by the width of the trapezoid which we will call  $\Delta x$ .

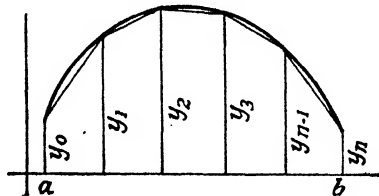

FIG. 685.

Then

$$\frac{1}{2}(y_0 + y_1)\Delta x = \text{area of the first trapezoid.}$$

$$\frac{1}{2}(y_1 + y_2)\Delta x = \text{area of second trapezoid.}$$

$$\frac{1}{2}(y_2 + y_3)\Delta x = \text{area of third trapezoid.}$$

⋮  
⋮  
⋮  
⋮

$$\frac{1}{2}(y_{n-1} + y_n)\Delta x = \text{area of the } n\text{th trapezoid.}$$



Adding the areas of the trapezoids for the total area from  $a$  to  $b$ , we get

$$\frac{1}{2}(y_0 + 2y_1 + 2y_2 + 2y_3 + \dots + 2y_{n-1} + y_n)\Delta x.$$

Therefore, the trapezoidal rule is

[696]  $\text{Area} = (\frac{1}{2}y_0 + y_1 + y_2 + y_3 + \dots + y_{n-1} + \frac{1}{2}y_n)\Delta x.$

EXAMPLE.—Calculate  $\int_1^{10} x^2 dx$  by trapezoidal rule.

Divide  $x = 1$  to  $x = 10$  into 9 spaces. Then each space or  $\Delta x = 1$ .

Substituting  $x = 1, x = 2, x = 3, \dots, x = 9$ , in  $y = x^2$ , for this is the curve under which we desire the area, then

$$y_0 = 1, y_1 = 4, y_2 = 9, \dots, y_n = 81.$$

Substituting in formula,

$$\begin{aligned} \text{Area} &= (\frac{1}{2} + 4 + 9 + 16 + 25 + 36 + 49 + 64 + 81 + \frac{1}{2}(100)); \\ &= 334\frac{1}{2}. \end{aligned}$$

By integration,

$$\int_1^{10} x^2 dx = \left[ \frac{x^3}{3} \right]_1^{10} = \frac{1000}{3} - \frac{1}{3} = 333.$$

This is an error of less than one-half of 1 per cent.

**1081. Simpson's Rule of Approximations.**—In place of drawing straight lines for the top of the trapezoids, a closer approximation can be made by using a parabolic curve and then summing up the areas under the arc. A parabolic curve can be drawn through any three points and the computed area will be closer to the exact area if such a curve is used than if the tops of the trapezoids are straight lines as are used in the trapezoidal rule.

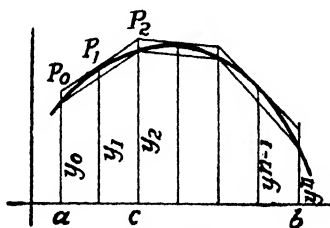

FIG. 686.

Divide the interval from  $a$  to  $b$  into  $n$  even number of spaces whose width is  $\Delta x$ . Through each set of three points on the curve, as  $P_0, P_1, P_2$ , consider parabolic arcs to be drawn.

Then the area of the strip  $aP_0P_1P_2c$  equals the area of the trapezoid plus the area of the parabolic segment  $P_0P_1P_2$ . But

$$\text{Area of the trapezoid} = \frac{1}{2}(y_0 + y_2)2\Delta x = (y_0 + y_2)\Delta x.$$

The area of the parabolic segment  $P_0P_1P_2$  equals two-thirds of the area of the circumscribed parallelogram.

$$\text{Area } P_0P_1P_2 = \frac{2}{3}(y_1 - \frac{1}{2}(y_0 + y_2))2\Delta x = \frac{2}{3}(2y_1 - y_0 - y_2)\Delta x.$$

Hence, the area of the first strip is

$$\begin{aligned} \text{Area} &= (y_0 + y_2)\Delta x + \frac{2}{3}(2y_1 - y_0 - y_2)\Delta x \\ &= \frac{\Delta x}{3}(y_0 + 4y_1 + y_2). \end{aligned}$$

The area of the remaining strips is found in the same manner.

The area of the second strip is

$$\frac{\Delta x}{3}(y_2 + 4y_3 + y_4).$$

The area of the third strip is

$$\frac{\Delta x}{3}(y_4 + 4y_5 + y_6).$$

The area of the last strip is

$$\frac{\Delta x}{3}(y_{n-2} + 4y_{n-1} + y_n).$$

Adding, we get

$$[\text{597}] \quad \text{Area} = \frac{\Delta x}{3}(y_0 + 4y_1 + 2y_2 + 4y_3 + 2y_4 + \dots + y_n),$$

which is Simpson's rule when  $n$  is even.

EXAMPLE.—Calculate  $\int_1^{10} x^2 dx$ , using Simpson's rule.

Take 10 spaces. Then  $\Delta x = .9$  unit.

Substituting the abscissae,

$x = 1, 1.9, 2.8, 3.7, 4.6, 5.5, 6.4, 7.3, 8.2, 9.1, 10.0,$

and the corresponding ordinates,

$y = 1, 3.61, 7.84, 13.69, 21.16, 30.25, 40.96, 53.29, 67.24, 82.81, 100,$

in Simpson's formula,

$$\begin{aligned} \text{Area} &= \frac{0.9}{3}[1 + 4(3.61) + 2(7.84) + 4(13.69) + 2(21.16) \\ &\quad + 4(30.25) + 2(40.96) + 4(53.29) + 2(67.24) \\ &\quad + 4(82.81) + 100]. \\ &= .3(1 + 14.44 + 15.68 + 54.76 + 42.32 + 121 + 81.92 \\ &\quad + 213.16 + 134.48 + 331.24 + 100) = .3(1110). \\ &= 333. \end{aligned}$$

This is the exact value of the integral, as we would expect, since the curve  $y = x^2$  is a parabola.

$\Delta x$  was purposely chosen fractional to show how the area could be computed in such a case.

**1082. Planimeter for Integration.**—The planimeter is an instrument which measures areas. It is also extensively used as well as the methods of approximation which have been given. Since the planimeter computes areas mechanically, it can be used in that way for integration. No special instruction is necessary provided one is familiar with the use of the instrument for finding areas.

The use of the instrument is restricted to definite integrals, that is, to the measurement of definite areas, such as an area between two curves which have been plotted, or the area between a curve and the  $X$ - or  $Y$ -axes within certain limits.

A tracing point is made to follow the perimeter or boundary curves of the figure to be measured, and the area is given by the reading of a recording wheel on the instrument.



## INDEX

### A

- Abscissa, 67
- Absolute errors, defined, 22
  - in addition, 24
  - in division, 34
  - in multiplication, 26
- Acceleration, angular, 589
  - defined, 588
  - graphs, 610
  - normal, 595
  - of mass, 601
  - problems, 707
- Addition, bankers, 1
  - change making, 4
  - checking, 1
  - checking by nines, 17
  - combined with subtraction, 3
  - double column, 2
  - period, 2
  - of radicals, 62
  - three column, 2
- Addition formulae for sines and cosines, 386
- Algebraic notation, 44
- Aliquot parts, 13
- Alternating current, 364
- Alternating series, 289
- Amplitude of complex numbers, 398
  - of sinusoid, 359
- Analytical geometry, 416
  - solid, 519
- Angles, defined, 320, 340
  - approximations for small, 352
  - between lines, 420
  - between two radius vectors, 521
  - complimentary, 346
  - eccentric, 467
  - formulae for, 343, 351
- Angles, defined, functions of, 343, 348
  - in space, 521
  - initial side of, 342
  - magnitude of, 340
  - negative, 347
  - tables of, 345
  - units of, measure of, 340
  - vectorial, 418
- Annulus, 331
- Annulus sector, 331
- Antilogs, 233
- Approximations, 21, 42, 43, 189, 295, 352, 764, 765, 767
- Arch, 453
- Arcs, differential, 631
  - length of, 714
- Area, areas, by double integration
  - 746, 751
- by integration, 670
  - by polar coordinates, 675
  - by summation method, 711
- equivalents, 673
- in parametric form, 689
- irregular, 334
- moments of, 753
- of ellipse, 332
- of fillet, 332
- of hyperbolic, 332
- of oblique triangles, 322, 424
- of prisms, 335
- of right triangles, 320
- of sectors, 331
- of spheres, 336
- Simpson's rule for, 334
- variable, 570, 660

- Arithmetical progression, 210
- Asymptotes, 472

## B

- Beams, bending moments of, 727, 732
  - resisting moments of, 732
  - shearing of, 727 to 732
  - strength of, 643
- Belts, centrifugal force of, 644
  - drives, 732
  - tandem, 724
- Bending moments, 727
- Binomial, factors, general method, 56
  - reduction, 55
- Binomial theorem, approximation, 295
  - expansion, 48
  - the  $n$ th term in, 49
  - series, 292, 294
- Boundary curves, 367

## C

- Calculus, differential, 551
  - integral, 666
- Centrifugal tension, 643
- Centroids, center of gravity, by
  - double integration, 753
  - of areas, 741, 754, 755
  - of lines, 740
  - of volumes, 742
- Change, of base, 236
  - rate of, 551
  - uniform, 551
- Circle, circumscribing a triangle, 322
  - equations, 454
  - formulae in geometry, 327
  - inscribed in triangles, 322
  - involute of, 497
  - parametric equations of, 455
  - polar equations of, 456
  - sector of, 331
  - segment of, 331
  - system of, 457
  - tangent to, 458
  - theorems, 328

- Circular functions, 342
- Clock problems, 95
- Coal pile problem, 710
- Cologarithms, 234
- Combinations, 312
- Commission, 80
- Complementary angles, 346
- Completing the square, 112
- Complex numbers, 392, 394
  - conjugate of, 396
  - division of, 397
  - multiplication of, 397
  - polar form of, 397, 399, 400
- Compound interest law, 240, 625, 722
- Concavity, 636
- Cone, 336, 528, 547
- Conic, equations of, 446
  - definition of, 446
  - differentiation of, 575
  - the elliptic form of, 462
  - the hyperbolic form of, 471
  - the parabolic form, 449
  - polar form of, 447
- Conjugate axes, 473
- Constants, added, 561
  - differentiation of, 560
  - integration, 667
  - times a function, 561
- Cooling law, 725
- Coordinate paper, 242
- Cosine, line segment, 416
  - polar, 342, 383, 417
  - rectangular, 342, 417
- Cosecant, 342
  - graphs of, 373
- Cosines, construction of, 266, 365
  - differentiation of, 606, 607
  - expansion in series of, 403, 652
  - exponential values of, 404
  - graphs of, 365
  - harmonic motion using, 265, 611
- Cotangent, graphs of, 372
  - graphs construction of, 372
- Crank and slot mechanism, 608, 609

- Cube root, by algebraic formula, 20  
 . short cut method for, 20  
 by slide rule, 264
- Cubes, 334
- Cubic functions, definition of, 171  
 derivative of, 579  
 graphs of, 171 to 183  
 shearing of, 173  
 translation of, 172
- Curve, continuous, analysis, 633  
 concavity of, 636  
 curvature, 645  
 curvilinear motion in, 593  
 discontinuous, 635  
 length of, 631, 714, 716  
 slope of, 634  
 in space, 523
- Cycloid, 334, 498, 499
- Cylinder, 335, 523, 548
- D
- Damped oscillations, 367
- Decimal point rule, 14
- Decreasing functions, 69, 552
- De Moivre's theorem, 401  
 application, 402
- Derivative, partial, 657  
 second, 576  
 successive partial, 662  
 total, 657
- Determinant, cofactor of, 304  
 definition of, 299  
 evaluation of, 306  
 factoring of, 308  
 minor of, 302  
 $n$ th order of, 304  
 properties of, 305  
 second order of, 299  
 simultaneous equations of, 299  
 third order of, 300
- Diameters to conics, 487
- Difference of two powers, 54
- Differentials, definition, 629
- Differentiation, application, 584  
 graphical illustrations, 566, 577
- Differentiation of algebraic functions, 563  
 of constant, 560  
 of cubic function, 579  
 of a derivative, 576  
 of an exponential function, 623  
 of a function of a function, 565  
 of implicit function, 665  
 of logarithmic functions, 618  
 of power functions, 562, 564, 567  
 of a product, 568  
 of trigonometric functions, 604  
 to 617  
 of two variables, 661  
 of a variable itself, 560  
 successive, 577, 578
- Discontinuous functions, 635
- Discount, 80
- Discriminant, 105
- Displacement, 586
- Distance between two points, 418, 419, 420
- Distance from a point to a line, 437
- Divergency of infinite series, by  
 comparison test, 281  
 by ratio test, 288
- Dividing a line in a ratio, 521
- Division, absolute errors in, 34, 35, 36  
 algebraic check, 58  
 by detached coefficients, 52  
 by factors, 16  
 by similar triangles, 323  
 check, by nines, 17  
 inspection in, 16  
 miscellaneous forms for, 57  
 of radicals, 63  
 short cuts, 37, 38
- E
- $e$ , Napierian base, 297, 404
- Eccentricity, 477
- Ellipse, area of, 332  
 conic equation of, 462  
 definition of, 459

- Ellipse, eccentric angle of, 467  
 eccentricity of, 463  
 focal radii, 463  
 foci of, 461  
 general form of, 465  
 graphs of, 130  
 parametric equation of, 496  
 perimeter of, 332  
 polar form of, 468  
 sheared, 141  
 translated, 464
- Ellipsoid, 337, 542
- Empirical equations, 506  
 of exponential form, 516  
 of polynomial form, 516  
 of power functions, 511, 514  
 straight line law of, 508
- Energy, 734
- Epicycloid, 500
- Equality, 71
- Equations, definitions of, 70  
 formation of, 426  
 integral, 71  
 setting up, 71  
 tabular method of, 73
- Equations, linear, analytical solutions of, 88  
 graphs of, 75, 76, 77, 84, 86, 87  
 graphs of simultaneous, 87, 88  
 intercept form of, 88  
 slope-intercept form of, 430  
 slope-point form of, 429  
 with three unknowns, 73  
 with two unknowns, 72, 429
- Equations, quadratic, analytical solutions of, 111  
 explicit form, graphs of, 99 to 127  
 general form, graphs of, 139 to 146  
 homogeneous form of, 146  
 implicit form, graphs of, 127 to 162  
 of higher degree, 153  
 of second degree, 446  
 other graphical solutions of, 157 to 160
- Equations, quadratic, simultaneous, 147  
 symmetrical simultaneous, 151  
 with irrational roots, 160  
 with three unknowns, 156
- Errors, absolute, 22  
 limiting, 22  
 relative, 22
- Evolution, by algebra, 19  
 by logarithms, 235
- Expansion, binomial, 48  
 of functions, 647
- Exponent, fractional, 65  
 negative, 65  
 values of sine and cosine, 404  
 zero, 65
- Exponential functions, 237  
 compared to logarithmic functions, 237  
 differentiation by graphs of, 626  
 equations of, 239  
 formulae of, 250  
 of complex numbers, 405  
 slope of, 239  
 subtangent, 239
- Extraneous roots, 164
- F
- Factor theorem, 56, 184
- Factoring, 18
- Factors, 52, 53
- Family of curves, 439, 457
- First degree equations (see equations), 83
- Fluid pressure, 719
- Force, definition, 601
- Fractions, by undeterminate coefficients, 313  
 defining, 162  
 equations of, 162 to 167  
 of radicals, 63  
 partial, 315  
 reduction of, 166
- Frequency in sine functions, 361
- Functions, circular, 342  
 cosine, 365



Functions, cubic, 171 to 183  
 definition, 66  
 discontinuous, 635  
 explicit, 99  
 exponential, 618, 623  
 hyperbolic, 406  
 implicit, 127  
 logarithmic, 237, 618, 700  
 of first degree, 68  
 periodic, 353  
 quadratic, 99, 127  
 sine, 349, 353  
 trigonometric, 342

## G

Gas, work done expanding, 725  
 General equations of, cosine functions, 366, 607  
 cubic functions, 174  
 explicit quadratic function, 100  
 exponential function, 250  
 first degree in three variables, 531  
 implicit quadratic functions, 139  
 logarithmic functions, 620  
 planes, 531  
 polynomial functions, 183  
 power functions, 201  
 sine functions, 357, 606  
 Geometric mean, 215  
 Geometric progression, 215  
 Geometry of, angles, 320  
 circle, 327  
 cone, 336  
 cylinder, 335  
 ellipse, 332  
 ellipsoid, 337  
 hyperbola, 333  
 irregular areas, 334  
 parabola, 333  
 paraboloid, 337  
 parallelogram, 324  
 polygons, 326  
 prismoidal formula, 338  
 prisms, 334  
 quadrilateral, 326

Geometry of, rectangle, 324  
 rhombus, 325  
 sector, 331  
 segment, 331  
 solids, 334  
 sphere, 336  
 surfaces, 334  
 trapezoid, 325  
 triangles, 320  
 wedge shaped volume, 338  
 Graphical, differentiation, 581  
 integration, 678, 749  
 Graphs, defined, 67  
 Graphs of, circular functions, 355 to 373  
 complex numbers, 396, 397, 399, 401  
 ellipse, 131, 141, 157, 160, 459, 486  
 exponential functions, 237, 238, 239, 623  
 geometrical series, 217, 218  
 hyperbolas, 132, 133, 134, 139, 158, 161, 469, 471, 472  
 integrals, 683  
 linear equations, 84, 85, 86  
 logarithmic and exponential curves, 238, 622  
 parabola, 99, 100, 101, 102, 103, 104, 105, 107, 108, 128, 140, 145, 159, 448, 449, 450, 451, 452, 453  
 parabolic arch, 453  
 power functions, 197, 198  
 products, 323  
 quadratic equations, 99 to 111  
 quotients, 323  
 simultaneous equations, 90, 97, 124, 157, 158, 159, 160, 178  
 sinusoids, 354, 364  
 tangents and cotangents, 370, 372

## H

Harmonic motion, 610, 611  
 Highest common factor (H. C. F.), 59

- Hindu method for quadratics, 112  
 Homogeneous quadratic equations, 146  
 Hyperbola, area of, 333  
   asymptotes of, 472  
   conic equation of, 471  
   conjugates of, 473  
   definition of, 469  
   eccentricity of, 446, 469  
   equations of, 132, 133, 134, 135, 469  
   equilateral, 132, 475  
   focal radii, 472  
   polar equation of, 478  
   rectangular, 132  
   shearing of, 143  
   translated, 474  
 Hyperbolic function, definitions of, 406  
   derivatives of, 616  
 Hyperbolic system of logs, 228, 235, 236, 407  
 Hyperboloid, 530, 543, 545  
 Hypocycloid, 500, 501
- I
- Imaginary numbers, addition of, 394  
   division of, 394  
   graphs of, 393  
   multiplication of, 394  
   subtraction of, 394  
 Impact, 736  
 Implicit quadratic equations, definition of, 127  
   differentiation of, 574, 665  
 Impulse, 674, 736  
 Increment, 555, 559  
 Indeterminate forms, 653  
 Infinity, 222  
 Inflection, 638  
 Integrals, 686  
 Integration, approximate, 764  
   areas by, 670  
   double integration, 746, 756  
   examples of, 722  
   fundamental form of, 691  
   Integration, graphical determination of constants of, 680  
     multiple, 743  
     partial, 743, 744, 745  
     successive, 706  
     volumes by, 761  
   Integration by, expansion, 690  
     graphical method, 678  
     inspection, 697  
     logarithmic forms, 699, 700  
     new variables, 691  
     parts, 695  
     reduction method, 690  
     summation method, 708  
     transposition, 697  
     trigonometric substitution, 703  
   Integration of, binomial forms, 700  
     constants, 667, 669  
     fractional powers, 703  
     partial fractions, 705  
     power functions, 668  
     quadratic forms, 702, 705  
     sums and differences, 670  
     trigonometric forms, 701  
   Intercept form of, general equation, 435  
     linear functions, 433  
     surfaces, 527  
   Interest, compound, 240, 625, 722  
     exact, 80  
     formulae, 78, 79  
     one day method, 80  
     six per cent method, 79  
   Interpolation, 230  
   Intersection of loci, 76, 123, 157, 178, 412  
   Inverse trigonometric functions, derivatives of, 614  
     graphs of, 369, 615  
   Involute of circle, 497  
   Irrational, equations, 167  
     roots, 160
- L
- Law of mean, 647  
   extended, 648

- Length of arc, 632  
 Limiting errors, 22  
 Limits, 555, 559, 655  
   decomposing, 688  
   interchanging, 688  
   lower, 686  
   upper, 686  
 Limniscate, 504  
 Linear functions, 69, 83, 92, 93, 94  
   general equation of, 531  
   in three variables, 531  
   intercept form of, 433  
   normal form of, 434  
   slope-intercept form of, 430  
   slope-point form of, 429  
   through a point and making an angle to a line, 438  
   through a point and perpendicular to a line, 437  
   two point form of, 432  
 Lines, divided in ratios, 422, 423  
   equation of, 83  
   in space, 538  
   parallel to axes, 431  
   parallel to plane, 541  
   product of, 444  
   second degree equations representing, 445  
   segments of, 416  
   system of, 439, 440, 441  
   through a given point, 437, 540  
 Logarithmic functions, differentiation of, 618  
   graphs of, 622  
 Logarithmic paper, 242  
 Logarithms, approximating, 241  
   bases of, 297, 619  
   by slide rule, 266  
   change of base of, 236  
   common, 229, 236  
   computations of, 231 to 236  
   decrement of, 241  
   division by, 233  
   formulae for, 242  
   graphs of, 243, 247, 248  
   increment of, 240  
   Logarithms, mantissa, 229, 231  
     modulus of system of, 237  
     natural or Napierian, 235  
     powers by, 234  
     series of, 298  
 Lowest common multiple, 60
- M
- Maclaurin's theorem, 651  
 Magnitude, 553  
 Mass, 601  
 Maximum, 106, 108, 109, 110, 637, 639  
 Mean, arithmetical, 211  
   geometrical, 215  
   harmonical, 218  
   ordinate, 687  
   values, 673, 687  
 Medians, 322, 325  
 Minimum, 106, 108, 109, 110, 637, 639  
 Modulus, of decay, 241  
   of log system, 237  
 Moment of inertia, by double integration, 756  
   of areas, 739  
   polar, 757, 758  
 Moments of force, 763  
 Momentum, 736  
 Multiplication, a new system of, 40, 41  
   absolute errors in, 26, 27, 28  
   algebraic forms for, 9  
   approximations in, 42  
   by aliquot parts, 13  
   by detached coefficients, 51  
   by multipliers ending in 1, 12  
   by similar triangles, 323  
   check by nines, 17  
   dropping right hand numbers in, 33  
   extended tables for, 3  
   in algebra, 52  
   of numbers ending in five, 7, 8  
   of radicals, 62

- Multiplication, relative errors in,  
 29, 30, 31, 32  
 short cuts, 4 to 33  
 supplement and complement  
 method of, 12
- N
- Naperian base, 235  
 Napier, John, 226  
 Natural system of logs, 235  
 Negative angles, 347  
 Net profit problems, 96, 97  
 Newton's approximation, 584  
 Newton's law of cooling, 725  
 Normal form, of conics, 486  
 of general equation of line, 435  
 of linear functions, 434  
 of system of lines, 444
- O
- Oblique axis, 417  
 Oblique triangle, 376  
 Ordinate of point, 67  
 Origin, 83  
 Orthocenter, 322
- P
- Parabolas, areas of, 333  
 conics reducing to, 449  
 construction of, 111, 451  
 directrix of, 448  
 equations of, 99 to 127, 447  
 focus of, 448  
 general equation of, 450  
 inverted, 448  
 latus rectum of, 449  
 length of arc of, 333  
 parametric equation of, 496, 497  
 polar equation of, 451  
 properties of, 487  
 semi-cubical, 197  
 shearing, 140, 145  
 translated, 101, 449
- Parabolic arch, 453  
 Paraboloid, elliptic, 546  
 hyperbolic, 547  
 of revolution, 337, 530  
 Parallelogram, 324  
 Parameters, 492  
 Parametric equations of, circle, 497  
 curve in space, 549  
 cycloid, 498  
 ellipse, 496  
 parabola, 496, 497  
 Partial differentiation, 657  
 Pascal's triangle, 50, 51  
 Path of projectile, 452, 725  
 Per cent problems, 77  
 Period in sine functions, 360, 387  
 Periodic oscillations, 366  
 Permutations, 311  
 Perpendicular lines, 421  
 Planes, bisecting, 538  
 distance from point to, 534  
 equations of, 533  
 system of, 535  
 through a point, 536  
 through three points, 537  
 Planimeter, 767  
 Point of inflection, 638  
 Polar, coordinate paper, 383  
 coordinates, 383, 385, 502  
 distance between points, 419  
 equation of circle, 456  
 equation of ellipse, 468  
 equation of hyperbola, 478  
 equation of parabola, 451  
 form of complex numbers, 397  
 graphs, 383  
 moment of inertia, 758  
 relations to rectangular coordinates, 385  
 Polygons, areas of, 426  
 construction of, 326, 327  
 regular, 326  
 similar, 327  
 Polynomial, 56  
 Polynomial functions, factor theorem for, 184

- Polynomial functions, forming  
 equations from roots of, 193  
 general form of, 183  
 graphs of, 189, 194  
 reduction of, 183  
 remainder theorem for, 183  
 roots of, 186, 187, 189, 192, 194  
 signs of, 195  
 synthetic method for, 185, 190
- Power, powers, approximate forms  
 of, 42  
 by logarithms, 234  
 by slide rule, 263, 269, 272  
 differentiation of, 567  
 formulae for, 65  
 integration of, 668  
 relative errors in, 39  
 series, 291
- Prismoidal formula, 338
- Prisms, 334, 335
- Products of two or more variables,  
 571
- Profit problems, 96
- Progression, arithmetical, 210  
 geometrical, 215  
 harmonical, 218
- Projection, in space, 525  
 curve, 526
- Proportion, 44, 45, 46, 262  
 by logarithms, 235
- Proportional dividers, 46, 47, 131
- Pythagoras theorem, 321
- Q
- Quadratic equations, analytical solu-  
 tions of, 111  
 equations in quadratic form, 116  
 Euclidean graphical method for,  
 119, 120, 121  
 factoring, 114  
 formation of, 114  
 formulae for, 113  
 general equation explicit form  
 of, 100, 451  
 graphical short cut for, 123
- Quadratic equations, graphs of, 99  
 Hindu method for, 112  
 implicit form of, 127  
 with irrational roots, 124
- Quadrilateral, 326
- Quadrinomial reductions, 55
- Quotient of two functions, 571
- R
- Radian, 340, 341
- Radicals, addition and subtraction  
 of, 62  
 definitions of, 61  
 division of, 63  
 multiplication of, 62  
 powers and roots of, 64
- Radius of curvature, 645
- Radius of gyration, 740
- Radius vector, 418
- Rate of change, average, 552  
 instantaneous, 552  
 of ordinates, 562  
 problems in, 597  
 relative, 625
- Ratio, 44
- Ratio tests for convergency, 283
- Ratio tests for divergency, 283
- Reciprocals, approximations of, 43  
 by logarithms, 235
- Rectangles, 324
- Relative errors, in addition, 25  
 in combined multiplication and  
 division, 39  
 in division, 35, 36  
 in multiplication, 29, 30, 31, 32  
 in numbers, 23  
 in powers and roots, 39
- Remainder theorem, 183
- Retained digits, 22
- Rhombus, 325
- Right angle triangle, 320, 374, 375
- Rolle's theorem, 647
- Roots, extraneous, 164, 165  
 irrational, 167  
 relative errors in, 39

- Rose, four leafed, 505  
 three leafed, 505  
 Rotation of axes, 482  
 Rounded numbers, 21
- S
- Secant, graphs of, 373  
 method, 483  
 Second degree equations, (see quadratics)  
 in three dimensions, 542  
 in two unknowns, 446  
 removal of first degree terms in, 481  
 rotation of axes, 482  
 Sector of circle, 331  
 Selling price, 80, 81  
 Series, alternating, 289  
 binomial, 292  
 Cauchy's ratio test for, 284  
 comparison test, 280  
 converging, 278, 281  
 directions for testing, 290  
 exponential, 296, 404  
 hyperbolic, 408  
 infinite, 278  
 logarithmic, 298  
 non-convergent, 279, 281  
 power, 291  
 ratio test of, 283  
 with negative terms, 287  
 Shearing, cubic equations, 175  
 power equations, 202  
 quadratic equation, 139  
 Significant figures, 21  
 Signs of trigonometric functions, 346  
 Simple harmonic motion, 358, 611  
 Simpson's rule, 334, 339, 765  
 Simultaneous, cubic equations, 178  
 linear equations, 299, 302, 303  
 quadratic equations, 147 to 161  
 trigonometric equations, 413  
 Sines, by slide rule, 265, 271  
 differentiation of, 604, 607  
 expanded in series, 404, 652  
 Sines, exponential values of, 404  
 graph construction of, 354  
 graphs of, 353  
 harmonic motion in, 611  
 integration of, 691, 695, 696, 701  
 law of, 376  
 polar graphs of, 384  
 Slide rule, A and B scales on, 263, 270  
 C and D scales on, 252  
 correction method by, 276  
 cosines by, 266  
 description of, 251  
 dividing by  $\pi$  with, 255, 261  
 division, regular setting by, 253  
 folded scales on, 254  
 form  $a \times b \times \text{variable quantity}$  with, 259  
 form  $a \times b \times c$  with folded scale with, 260  
 form  $\frac{a}{b} \times \text{variable quantity}$  with, 257  
 form  $\frac{a}{b} \times \frac{1}{\text{variable quantity}}$  with, 258  
 form  $xy = c$  with, 257  
 general form with, 267  
 inverted and folded scales on, 256  
 inverted scales on, 256  
 K scales on, 264  
 log L scale on, 252  
 logarithms by, 267  
 multiplication, regular setting by, 253  
 multiplying by  $\pi$  with, 255, 261  
 powers by, 271, 272  
 proportions by, 262  
 reciprocals by, 257, 268  
 sine scale on, 265, 271  
 tangent scale on, 264, 270  
 triangles solved by, 274  
 Slope, 83, 239, 420, 421, 572  
 Slope-intercept form of linear functions, 430  
 Solids, 334, 335

- Space-time curves, 588  
 Speed, 586, 593  
 Sphere, 336, 337, 524  
 Spheroid, oblate, 529  
     prolate, 530  
 Spirals, Archimedes, 503  
     logarithmic, 504  
     parabolic, 503  
     reciprocal, 503  
 Square root, 19  
 Squaring, by slide rule, 263  
     numbers ending in 5, 6  
     numbers ending in  $\frac{1}{2}$ , 6  
     polynomials, 53  
 Subnormal, 490  
 Subtangent, 490  
 Subtraction, Austrian method of, 2  
     check by nines in, 17  
     complement method of, 3  
     of radicals, 62  
 Sum of two powers, 54  
 Summation method of integration,  
     areas by, 711  
     description of, 708  
     fluid pressure on walls by, 719  
     moments by, 763  
     polar areas by, 712  
     surfaces of revolution by, 717  
     volumes by, 717  
     work of lifting fluids by, 719  
 Supply and demand, 82  
 Surfaces, 522  
     of revolution, 527  
 System of lines, 439 to 444
- T
- Tangent,  
     derivative of, 612  
     equation of, 484  
     graphs of, 370  
     scale on slide rule, 264  
     slope of, 557  
     to conics, 484  
     to curves, 483  
 Taylor's theorem, 649
- Tensor, 398  
 Theorem, binomial, 48  
     factor, 56, 184  
     remainder, 183  
 Time and distance problems, 74  
 Time graphs in sine functions, 357,  
     387  
 Torus, 337  
 Total differentiation, 659  
 Transformation coordinates, 101, 102  
 Translation of second degree equa-  
     tions, 481  
 Trapezoid, 325  
 Trapezoidal rule for areas, 764  
 Triangle, triangles, any plane, 321, 322  
     areas of, 320, 321, 424, 425  
     congruent, 323  
     division by similar, 324  
     equilateral geometrical relations  
         of, 321  
     geometrical relations of, 320  
     logarithmic solutions of, 375  
     multiplication by similar, 323  
     oblique, 274, 376  
     right, 273, 374  
     similar, 323  
     solution by slide rule of, 274  
     solution of trigonometry of, 377  
         to 382  
 Trigonometric functions, definitions  
     of, 340  
     derivatives of, 612  
     derivatives of inverse functions  
         of, 614  
     differentiation of, 604  
     equations of, 410  
     formulae of, 348 to 351  
     graphical representation of, 346  
     graphical solutions of, 412  
     negative angles of, 347  
     signs of, 346  
     simultaneous equations of, 413  
 Trinomials, general form of, 54  
     special forms of, 54, 55  
     which are perfect squares, 54  
 Trochoid, 500

## V

- Variables, change of, 199, 365, 369, 615  
    dependent, 663  
    independent, 67
- Variables and limits, 554
- Vectorial angles, 418
- Vectors, 390
- Velocity, angular, 589  
    by areas, 674  
    components in space, 633  
    curvilinear, 593  
    definition of, 586  
    graphs of, 610  
    instantaneous, 590  
    mean, 590  
    time curves, 589
- Versor, 398
- Vertex, 107
- Vibrations, damped, 367
- Volumes, by areas, 674  
    by prismoidal formula, 338
- Volumes, by Simpson's rule, 339  
    by triple integration, 761  
    of cones, 336  
    of cubes, 334  
    of cylinders, 335  
    of paraboloids, 337  
    of prisms, 334  
    of solids of revolution, 717  
    of spheres, 336  
    of wedge shapes, 338

## W

- Waves, 357
- Wedge shaped volumes, 338
- Work, areas representing, 674  
    of lifting fluids, 719  
    problems, 83, 90, 91  
    relations, 736

## Z

- Zero, forms, 60  
    operations with, 60







This book is issued for  
7 DAYS ONLY.